

FCC Radio Test Report

FCC ID: KA2IRX1870A1

This report concerns: Class II Permissive Change

Project No. : 2007H027A
Equipment : AX1800 Mesh Wi-Fi 6 Router
Brand Name : D-Link
Test Model : DIR-X1870
Series Model : N/A
Applicant : D-Link Corporation
Address : 17595 Mt. Herrmann, Fountain Valley, California United State 92708
Manufacturer : D-Link Corporation
Address : 17595 Mt. Herrmann, Fountain Valley, California United State 92708
Date of Receipt : Sep. 01, 2020
Date of Test : Sep. 01, 2020~Sep. 28, 2020
Issued Date : Oct. 28,2020
Report Version : R00
Test Sample : Engineering Sample No.: SH20200716113-1, SH20200716113-6
Standard(s) : FCC Part15, Subpart E(15.407)
ANSI C63.10-2013
FCC KDB 789033 D02 General UNII Test Procedures New Rules v02r01
FCC KDB 662911 D01 Multiple Transmitter Output v02r01

Allen Wei

Prepared by : Allen Wei

Ryan Wang

Approved by : Ryan Wang



Certificate # 5123. 03

Add: No. 29, Jintang Road, Tangzhen Industry Park, Pudong New Area, Shanghai 201210, China

TEL: +86-021-61765666

Web: www.newbtl.com

Declaration

BTL represents to the client that testing is done in accordance with standard procedures as applicable and that test instruments used has been calibrated with standards traceable to international standard(s) and/or national standard(s).

BTL's reports apply only to the specific samples tested under conditions. It is manufacture's responsibility to ensure that additional production units of this model are manufactured with the identical electrical and mechanical components. **BTL** shall have no liability for any declarations, inferences or generalizations drawn by the client or others from **BTL** issued reports.

The report must not be used by the client to claim product certification, approval, or endorsement by NVLAP, NIST, A2LA, or any agency of the U.S. Government.

This report is the confidential property of the client. As a mutual protection to the clients, the public and ourselves, the test report shall not be reproduced, except in full, without our written approval.

BTL's laboratory quality assurance procedures are in compliance with the **ISO/IEC 17025** requirements, and accredited by the conformity assessment authorities listed in this test report.

BTL is not responsible for the sampling stage, so the results only apply to the sample as received.

The information, data and test plan are provided by manufacturer which may affect the validity of results, so it is manufacturer's responsibility to ensure that the apparatus meets the essential requirements of applied standards and in all the possible configurations as representative of its intended use.

Limitation

For the use of the authority's logo is limited unless the Test Standard(s)/Scope(s)/Item(s) mentioned in this test report is (are) included in the conformity assessment authorities acceptance respective.

Please note that the measurement uncertainty is provided for informational purpose only and are not use in determining the Pass/Fail results.

Table of Contents	Page
REPORT ISSUED HISTORY	5
1 . SUMMARY OF TEST RESULTS	6
1.1 TEST FACILITY	7
1.2 MEASUREMENT UNCERTAINTY	7
1.3 TEST ENVIRONMENT CONDITIONS	7
2 . GENERAL INFORMATION	8
2.1 GENERAL DESCRIPTION OF EUT	8
2.2 TEST MODES	11
2.3 PARAMETERS OF TEST SOFTWARE	13
2.4 DUTY CYCLE	15
2.5 BLOCK DIAGRAM SHOWING THE CONFIGURATION OF SYSTEM TESTED	18
2.6 SUPPORT UNITS	18
3 . AC POWER LINE CONDUCTED EMISSIONS TEST	19
3.1 LIMIT	19
3.2 TEST PROCEDURE	19
3.3 DEVIATION FROM TEST STANDARD	19
3.4 TEST SETUP	20
3.5 EUT OPERATION CONDITIONS	20
3.6 TEST RESULTS	20
4 . RADIATED EMISSIONS TEST	21
4.1 LIMIT	21
4.2 TEST PROCEDURE	22
4.3 DEVIATION FROM TEST STANDARD	22
4.4 TEST SETUP	23
4.5 EUT OPERATION CONDITIONS	25
4.6 TEST RESULTS - 9 KHZ to 30 MHZ	25
4.7 TEST RESULTS - 30 MHz TO 1000 MHz	25
4.8 TEST RESULTS - ABOVE 1000 MHz	25
5 . BANDWIDTH TEST	26
5.1 LIMIT	26
5.2 TEST PROCEDURE	26
5.3 TEST PROCEDURE	26
5.4 TEST SETUP	27

Table of Contents	Page
5.5 EUT OPERATION CONDITIONS	27
5.6 TEST RESULTS	27
6 . MAXIMUM OUTPUT POWER TEST	28
6.1 LIMIT	28
6.2 TEST PROCEDURE	28
6.3 DEVIATION FROM STANDARD	28
6.4 TEST SETUP	28
6.5 EUT OPERATION CONDITIONS	28
6.6 TEST RESULTS	28
7 . POWER SPECTRAL DENSITY TEST	29
7.1 LIMIT	29
7.2 TEST PROCEDURE	29
7.3 DEVIATION FROM STANDARD	29
7.4 TEST SETUP	30
7.5 EUT OPERATION CONDITIONS	30
7.6 TEST RESULTS	30
8 . FREQUENCY STABILITY MEASUREMENT	31
8.1 LIMIT	31
8.2 TEST PROCEDURE	31
8.3 DEVIATION FROM STANDARD	31
8.4 TEST SETUP	32
8.5 EUT OPERATION CONDITIONS	32
8.6 TEST RESULTS	32
9 . MEASUREMENT INSTRUMENTS LIST	33
10 . EUT TEST PHOTOS	35
APPENDIX A - AC POWER LINE CONDUCTED EMISSIONS	38
APPENDIX B - RADIATED EMISSION - 9 KHZ TO 30 MHZ	41
APPENDIX C - RADIATED EMISSION - 30 MHZ TO 1 GHZ	42
APPENDIX D - RADIATED EMISSION - ABOVE 1000 MHZ	45
APPENDIX E - BANDWIDTH	182
APPENDIX F - CONDUCTED OUTPUT POWER	192
APPENDIX G - POWER SPECTRAL DENSITY	226

REPORT ISSUED HISTORY

Report Version	Description	Issued Date
R00	Original Issue.	Oct. 28,2020

1. SUMMARY OF TEST RESULTS

Test procedures according to the technical standard(s):

FCC Part15, Subpart E(15.407)				
Standard(s) Section	Test Item	Test Result	Judgement	Remark
15.207 15.407(b)	AC Power Line Conducted Emissions	APPENDIX A	PASS	-----
15.407(b) 15.205(a) 15.209(a)	Radiated Emissions	APPENDIX B APPENDIX C APPENDIX D	PASS	-----
15.407(a) 15.407(e)	Spectrum Bandwidth	APPENDIX E	PASS	-----
15.407(a)	Maximum Output Power	APPENDIX F	PASS	-----
15.407(a)	Power Spectral Density	APPENDIX G	PASS	-----
15.203	Antenna Requirements	-----	PASS	NOTE (3)
15.407(c)	Automatically Discontinue Transmission	-----	PASS	NOTE (3)

Note:

- (1) "N/A" denotes test is not applicable in this test report.
- (2) The device what use a permanently attached antenna were considered sufficient to comply with the provisions of 15.203.
- (3) During no any information transmission, the EUT can automatically discontinue transmission and become standby mode for power saving. the EUT can detect the controlling signal of ACK message transmitting from remote device and verify whether it shall resend or discontinue transmission.

1.1 TEST FACILITY

The test facilities used to collect the test data in this report is at the location of No. 29, Jintang Road, Tangzhen Industry Park, Pudong New Area, Shanghai 201210,China

BTL's Test Firm Registration Number for FCC: 476765

BTL's Designation Number for FCC: CN1241

1.2 MEASUREMENT UNCERTAINTY

ISO/IEC 17025 requires that an estimate of the measurement uncertainties associated with the emissions test results be included in the report. The measurement uncertainties given below are based on a 95% confidence level (based on a coverage factor (k=2))

The BTL measurement uncertainty as below table:

A. Radiated emissions test:

Test Site	Method	Measurement Frequency Range	Ant. H / V	U, (dB)
SH-CB01	CISPR	9 KHz~30 MHz	V	3.79
		9 KHz~30 MHz	H	3.57
		30 MHz~200 MHz	V	4.04
		30 MHz~200 MHz	H	3.76
		200 MHz~1,000 MHz	V	4.24
		200 MHz~1,000 MHz	H	3.84
		1 GHz~18 GHz	V	4.46
		1 GHz~18 GHz	H	4.40
		18 GHz~40 GHz	V	3.95
		18 GHz~40 GHz	H	3.95

Note: Unless specifically mentioned, the uncertainty of measurement has not been taken into account to declare the compliance or non-compliance to the specification.

1.3 TEST ENVIRONMENT CONDITIONS

Test Item	Temperature	Humidity	Test Voltage	Tested By
AC Power Line Conducted Emissions	24°C	56%	AC 120V/60Hz	Forest
Radiated Emissions-9K-30MHz	23°C	52%	AC 120V/60Hz	Forest
Radiated Emissions-30 MHz to 1GHz	23°C	52%	AC 120V/60Hz	Forest
Radiated Emissions-Above 1000 MHz	23°C	52%	AC 120V/60Hz	Forest
Spectrum Bandwidth	24°C	56%	AC 120V/60Hz	Forest
Maximum Output Power	24°C	56%	AC 120V/60Hz	Forest
Power Spectral Density	24°C	56%	AC 120V/60Hz	Forest

2. GENERAL INFORMATION

2.1 GENERAL DESCRIPTION OF EUT

Equipment	AX1800 Mesh Wi-Fi 6 Router
Brand Name	D-Link
Test Model	DIR-X1870
Series Model	N/A
Model Difference(s)	N/A
Software Version	1
Hardware Version	A1
Power Source	DC voltage supplied from AC/DC adapter. 1#Brand/Mode: S12A12-120A100-CJ 2#Brand/Mode: WB-12G12R
Power Rating	1# I/P: 100V-240V ~ 50Hz/60Hz Max0.5A, O/P:12V === 1A. 2# I/P: 100V-240V ~ 50Hz/60Hz 0.3A Max, O/P:12V === 1.0A.12W
Operation Frequency	UNII-2A: 5250 MHz~5350 MHz UNII-2C: 5470 MHz~5725 MHz
Modulation Type	OFDM
Bit Rate of Transmitter	Up to 1730 Mbps Mbps
Maximum Conducted Output Power for UNII-2A (1TX) CDD	IEEE 802.11a: 16.59 dBm (0.0456 W)
Maximum Conducted Output Power for UNII-2C (1TX) CDD	IEEE 802.11a: 17.96 dBm (0.0625 W)
Maximum Conducted Output Power for UNII-2A (2TX) CDD	IEEE 802.11n (HT20): 16.86 dBm (0.0485 W) IEEE 802.11n (HT40): 19.08 dBm (0.0809 W) IEEE 802.11ac (VHT20): 16.68 dBm (0.0466 W) IEEE 802.11ac (VHT40): 19.27 dBm (0.0845 W) IEEE 802.11ac (VHT80): 23.95 dBm (0.2483 W) IEEE 802.11ax (HE20): 16.17 dBm (0.0414 W) IEEE 802.11ax (HE40): 23.76 dBm (0.2377 W) IEEE 802.11ax (HE80): 16.43 dBm (0.0440 W)
Maximum Conducted Output Power for UNII-2C (2TX) CDD	IEEE 802.11n (HT20): 18.32 dBm (0.0679 W) IEEE 802.11n (HT40): 21.40 dBm (0.1380 W) IEEE 802.11ac (VHT20): 18.06 dBm (0.0640 W) IEEE 802.11ac (VHT40): 21.00 dBm (0.1259 W) IEEE 802.11ac (VHT80): 23.79 dBm (0.2393 W) IEEE 802.11ax (HE20): 17.45 dBm (0.0556 W) IEEE 802.11ax (HE40): 20.26 dBm (0.1062 W) IEEE 802.11ax (HE80): 23.34 dBm (0.2158 W)

Maximum Conducted Output Power for UNII-2A (2TX) Beamforming	IEEE 802.11n (HT20): 16.58 dBm (0.0455 W) IEEE 802.11n (HT40): 19.03 dBm (0.0800 W) IEEE 802.11ac (VHT20): 16.60 dBm (0.0457 W) IEEE 802.11ac (VHT40): 19.16 dBm (0.0824 W) IEEE 802.11ac (VHT80): 23.71 dBm (0.2350 W) IEEE 802.11ax (HE20): 15.86 dBm (0.0385 W) IEEE 802.11ax (HE40): 21.05 dBm (0.1274 W) IEEE 802.11ax (HE80): 16.26 dBm (0.0423 W)
Maximum Conducted Output Power for UNII-2C (2TX) Beamforming	IEEE 802.11n (HT20): 18.29 dBm (0.0675 W) IEEE 802.11n (HT40): 21.22 dBm (0.1324 W) IEEE 802.11ac (VHT20): 17.95 dBm (0.0624 W) IEEE 802.11ac (VHT40): 20.65 dBm (0.1161 W) IEEE 802.11ac (VHT80): 23.12 dBm (0.2051 W) IEEE 802.11ax (HE20): 17.18 dBm (0.0522 W) IEEE 802.11ax (HE40): 19.99 dBm (0.0998 W) IEEE 802.11ax (HE80): 21.18 dBm (0.1312 W)

Note:

1. For a more detailed features description, please refer to the manufacturer's specifications or the user's manual.

2. Channel List:

IEEE 802.11a IEEE 802.11n (HT20) IEEE 802.11ac (VHT20) IEEE 802.11ax (HE20)		IEEE 802.11n (HT40) IEEE 802.11ac (VHT40) IEEE 802.11ax (HE40)		IEEE 802.11ac (VHT80) IEEE 802.11ax (HE80)	
UNII-2A		UNII-2A		UNII-2A	
Channel	Frequency (MHz)	Channel	Frequency (MHz)	Channel	Frequency (MHz)
52	5260	54	5270	58	5290
56	5280	62	5310		
60	5300				
64	5320				

IEEE 802.11a IEEE 802.11n (HT20) IEEE 802.11ac (VHT20) IEEE 802.11ax (HE20)		IEEE 802.11n (HT40) IEEE 802.11ac (VHT40) IEEE 802.11ax (HE40)		IEEE 802.11ac (VHT80) IEEE 802.11ax (HE80)	
UNII-2C		UNII-2C		UNII-2C	
Channel	Frequency (MHz)	Channel	Frequency (MHz)	Channel	Frequency (MHz)
100	5500	102	5510	106	5530
104	5520	110	5550	122	5610
108	5540	118	5590		
112	5560	126	5630		
116	5580	134	5670		
120	5600				
124	5620				
128	5640				
132	5660				
136	5680				
140	5700				

3. Antenna Specification:

Ant.	Brand	Model Name	Antenna Type	Connector	Gain (dBi)	Note
1	N/A	N/A	Dipole	N/A	5	N/A
2	N/A	N/A	Dipole	N/A	5	N/A

Note:

(1) Beamforming:

All antennas have the same gain, Directional gain = $G_{ANT} + 10 \log(N_{ANT})$ dBi,
that is Directional gain = $5 + 10 \log(2)$ dBi = 8.01;

So output power limit is $24 - 8.01 + 6 = 21.99$, the UNII-2A power density limit is $11 - (8.01 - 6) = 8.99$. the UNII-2C power density limit is $24 - 8.01 + 6 = 21.99$.

(2) CDD:

All antennas have the same gain, Directional gain = $G_{ANT} + \text{Array Gain}$,

For power spectral density measurements, $N_{ANT} = 2$, $N_{SS} = 1$.

So Directional gain = $G_{ANT} + \text{Array Gain} = 10 \log(N_{ANT}/N_{SS})$ dB = $5 + 10 \log(2/1)$ dBi = 8.01.

Then, the UNII-2A power density limit is $11 - (8.01 - 6) = 8.99$.

the UNII-2C power density limit is $24 - 8.01 + 6 = 21.99$

For power measurements, Array Gain = 0 dB ($N_{ANT} \leq 4$), so the Directional gain = 5.

4. Table for Antenna Configuration:

Operating Mode TX Mode	Ant. 1	Ant. 2	Ant. 1+2
	IEEE 802.11a	✓	✓
IEEE 802.11n (HT20)	✓	✓	✓
IEEE 802.11n (HT40)	✓	✓	✓
IEEE 802.11ac (VHT20)	✓	✓	✓
IEEE 802.11ac (VHT40)	✓	✓	✓
IEEE 802.11ac (VHT80)	✓	✓	✓
IEEE 802.11ax (HE20)	✓	✓	✓
IEEE 802.11ax (HE40)	✓	✓	✓
IEEE 802.11ax (HE80)	✓	✓	✓

2.2 TEST MODES

The test system was pre-tested based on the consideration of all possible combinations of EUT operation mode.

Pretest Mode	Description
Mode 1	TX A Mode / CH52, CH60, CH64 (UNII-2A)
Mode 2	TX N (HT20) Mode / CH52, CH60, CH64 (UNII-2A)
Mode 3	TX N (HT40) Mode / CH54, CH62 (UNII-2A)
Mode 4	TX AC (VHT20) Mode / CH52, CH60, CH64 (UNII-2A)
Mode 5	TX AC (VHT40) Mode / CH54, CH62 (UNII-2A)
Mode 6	TX AC (VHT80) Mode / CH58 (UNII-2A)
Mode 7	TX AC(VHT80) Mode / CH58 (UNII-2A)
Mode 8	TX AX (HE20) Mode / CH36, CH40, CH48 (UNII-2A)
Mode 9	TX AX (HE40) Mode / CH38, CH46 (UNII-2A)
Mode 10	TX AX (HE80) Mode / CH42 (UNII-2A)
Mode 11	TX A Mode / CH100, CH116, CH140 (UNII-2C)
Mode 12	TX N (HT20) Mode / CH100, CH116, CH140 (UNII-2C)
Mode 13	TX N (HT40) Mode / CH102, CH110, CH134 (UNII-2C)
Mode14	TX AC (VHT20) Mode / CH100, CH116, CH140 (UNII-2C)
Mode 15	TX AC (VHT40) Mode / CH102, CH110, CH134 (UNII-2C)
Mode 16	TX AC (VHT80) Mode / CH106, CH122 (UNII-2C)
Mode17	TX AX (HE20) Mode / CH149,CH157,CH165 (UNII-2C)
Mode 18	TX AX (HE40) Mode / CH151,CH159 (UNII-2C))
Mode 19	TX AX (HE80) Mode / CH155 (UNII-2C)

Following mode(s) as (were) found to be the worst case(s) and selected for the final test.

AC power line conducted emissions test	
Final Test Mode	Description
Mode 13	TX AC(VHT80) Mode / CH58 (UNII-2A)

Radiated emissions test	
Final Test Mode	Description
Mode 1	TX A Mode / CH52, CH60, CH64 (UNII-2A)
Mode 2	TX AC (VHT20) Mode / CH52, CH60, CH64 (UNII-2A)
Mode 3	TX AC (VHT40) Mode / CH54, CH62 (UNII-2A)
Mode 4	TX AC (VHT80) Mode / CH58 (UNII-2A)
Mode 5	TX AX (HE20) Mode / CH36, CH40, CH48 (UNII-2A)
Mode 6	TX AX (HE40) Mode / CH38, CH46(UNII-2A)
Mode 7	TX AX (HE80) Mode / CH42 (UNII-2A)
Mode 8	TX A Mode / CH100, CH116, CH140 (UNII-2C)
Mode 9	TX AC (VHT20) Mode / CH100, CH116, CH140 (UNII-2C)
Mode 10	TX AC (VHT40) Mode / CH102, CH110, CH134 (UNII-2C)
Mode 11	TX AC (VHT80) Mode / CH106, CH122 (UNII-2C)
Mode 12	TX AX (HE20) Mode / CH149,CH157,CH165 (UNII-2C)
Mode 13	TX AX (HE40) Mode / CH151,CH159 (UNII-2C)
Mode14	TX AX (HE80) Mode / CH155 (UNII-2C)

Conducted test	
Test Mode	Description
Mode 1	TX A Mode / CH52, CH60, CH64 (UNII-2A)
Mode 2	TX N (HT20) Mode / CH52, CH60, CH64 (UNII-2A)
Mode 3	TX N (HT40) Mode / CH54, CH62 (UNII-2A)
Mode 4	TX AC (VHT20) Mode / CH52, CH60, CH64 (UNII-2A)
Mode 5	TX AC (VHT40) Mode / CH54, CH62 (UNII-2A)
Mode 6	TX AC (VHT80) Mode / CH58 (UNII-2A)
Mode 7	TX AX (HE20) Mode / CH36, CH40, CH48 (UNII-2A)
Mode 8	TX AX (HE40) Mode / CH38, CH46 (UNII-2A)
Mode 9	TX AX (HE80) Mode / CH42 (UNII-2A)
Mode 10	TX A Mode / CH100, CH116, CH140 (UNII-2C)
Mode 11	TX N (HT20) Mode / CH100, CH116, CH140 (UNII-2C)
Mode 12	TX N (HT40) Mode / CH102, CH110, CH134 (UNII-2C)
Mode 13	TX AC (VHT20) Mode / CH100, CH116, CH140 (UNII-2C)
Mode14	TX AC (VHT40) Mode / CH102, CH110, CH134 (UNII-2C)
Mode 15	TX AC (VHT80) Mode / CH106, CH122 (UNII-2C)
Mode 16	TX AX (HE20) Mode / CH149,CH157,CH165 (UNII-2C)
Mode17	TX AX (HE40) Mode / CH151,CH159 (UNII-2C)
Mode 18	TX AX (HE80) Mode / CH155 (UNII-2C)

Note:

- (1) For radiated emission below 1 GHz test, the IEEE 802.11ac80 is found to be the worst case and recorded.

2.3 PARAMETERS OF TEST SOFTWARE
CDD

UNII-2A - 1TX			
Test Software	accessMTool.3.1.0.6		
Test Frequency (MHz)	5260	5300	5320
IEEE 802.11a	78	80	79

UNII-2C - 1TX			
Test Software	accessMTool.3.1.0.6		
Test Frequency (MHz)	5500	5580	5700
IEEE 802.11a	75	76	73

UNII-2A - 2TX			
Test Software	accessMTool.3.1.0.6		
Test Frequency (MHz)	5260	5300	5320
IEEE 802.11n (HT20)	69	69	69
IEEE 802.11ac (VHT20)	69	69	69
IEEE 802.11ax (HE20)	68	68	67
Test Frequency (MHz)	5270	5310	
IEEE 802.11n (HT40)	82	72	
IEEE 802.11ac (VHT40)	82	72	
IEEE 802.11ax (HE40)	81	72	
Test Frequency (MHz)	5290		
IEEE 802.11ac (VHT80)	85		
IEEE 802.11ax (HE80)	70		

UNII-2C - 2TX			
Test Software	accessMTool.3.1.0.6		
Test Frequency (MHz)	5500	5580	5700
IEEE 802.11n (HT20)	67	63	64
IEEE 802.11ac (VHT20)	67	63	64
IEEE 802.11ax (HE20)	65	64	64
Test Frequency (MHz)	5510	5550	5670
IEEE 802.11n (HT40)	71	77	79
IEEE 802.11ac (VHT40)	71	77	79
IEEE 802.11ax (HE40)	68	77	78
Test Frequency (MHz)	5530	5610	
IEEE 802.11ac (VHT80)	72	85	
IEEE 802.11ax (HE80)	71	80	

Beamforming

UNII-2A - 2TX			
Test Software	accessMTool.3.1.0.6		
Test Frequency (MHz)	5260	5300	5320
IEEE 802.11n (HT20)	69	69	69
IEEE 802.11ac (VHT20)	69	69	69
IEEE 802.11ax (HE20)	68	68	67
Test Frequency (MHz)	5270	5310	
IEEE 802.11n (HT40)	82	72	
IEEE 802.11ac (VHT40)	82	72	
IEEE 802.11ax (HE40)	79	72	
Test Frequency (MHz)	5290		
IEEE 802.11ac (VHT80)	80		
IEEE 802.11ax (HE80)	70		

UNII-2C - 2TX			
Test Software	accessMTool.3.1.0.6		
Test Frequency (MHz)	5500	5580	5700
IEEE 802.11n (HT20)	67	63	64
IEEE 802.11ac (VHT20)	67	63	64
IEEE 802.11ax (HE20)	65	64	64
Test Frequency (MHz)	5510	5550	5670
IEEE 802.11n (HT40)	71	77	79
IEEE 802.11ac (VHT40)	71	77	79
IEEE 802.11ax (HE40)	68	77	78
Test Frequency (MHz)	5530	5610	
IEEE 802.11ac (VHT80)	72	80	
IEEE 802.11ax (HE80)	71	78	

2.4 DUTY CYCLE

If duty cycle is $\geq 98\%$, duty factor is not required.
 If duty cycle is $< 98\%$, duty factor shall be considered.
 The output power = measured power + duty factor.

IEEE 802.11a

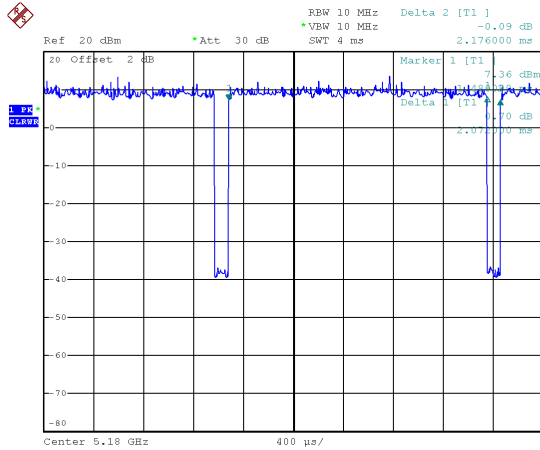

IEEE 802.11n (HT20)

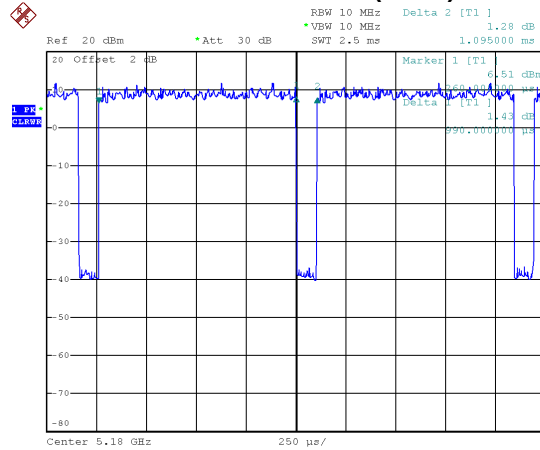

Date: 21.JUL.2020 12:29:58

Duty cycle = $2.072\text{ ms} / 2.176\text{ ms} = 95.22\%$
 Duty Factor = $10 * \log(1 / \text{Duty cycle}) = 0.21\text{ dB}$

Date: 21.JUL.2020 12:30:31

Duty cycle = $0.990\text{ ms} / 1.095\text{ ms} = 90.41\%$
 Duty Factor = $10 * \log(1 / \text{Duty cycle}) = 0.44\text{ dB}$

IEEE 802.11n (HT40)

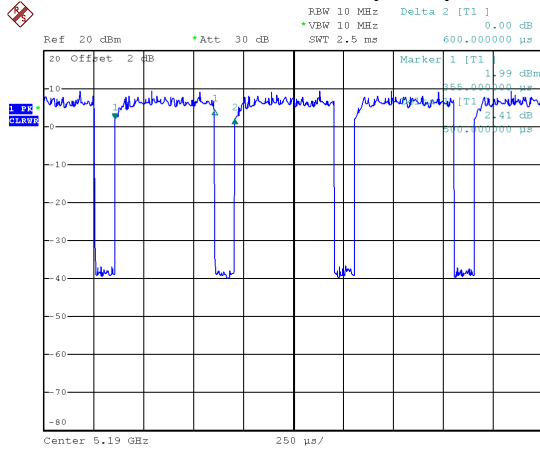

IEEE 802.11ac (VHT20)

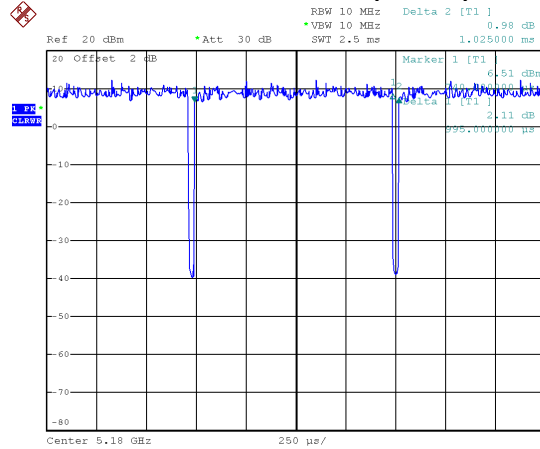

Date: 21.JUL.2020 12:32:54

Duty cycle = $0.500\text{ ms} / 0.600\text{ ms} = 83.33\%$
 Duty Factor = $10 * \log(1 / \text{Duty cycle}) = 0.79\text{ dB}$

Date: 21.JUL.2020 12:31:18

Duty cycle = $0.995\text{ ms} / 1.025\text{ ms} = 97.07\%$
 Duty Factor = $10 * \log(1 / \text{Duty cycle}) = 0.13\text{ dB}$

IEEE 802.11ac (VHT40)

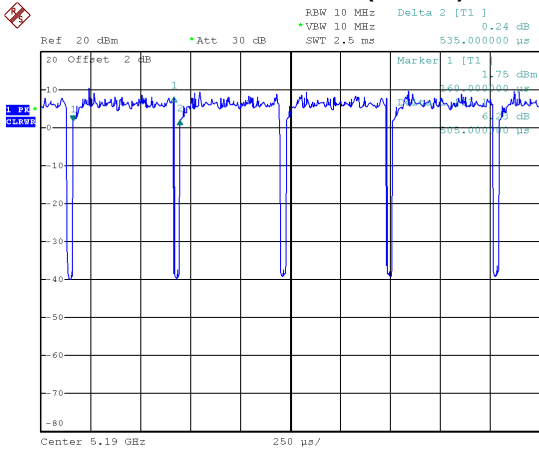

Date: 21.JUL.2020 12:31:58

Duty cycle = 0.505 ms / 0.535 ms = 94.39%
 Duty Factor = 10 * log(1 / Duty cycle) = 0.25 dB

IEEE 802.11ax (HE20)

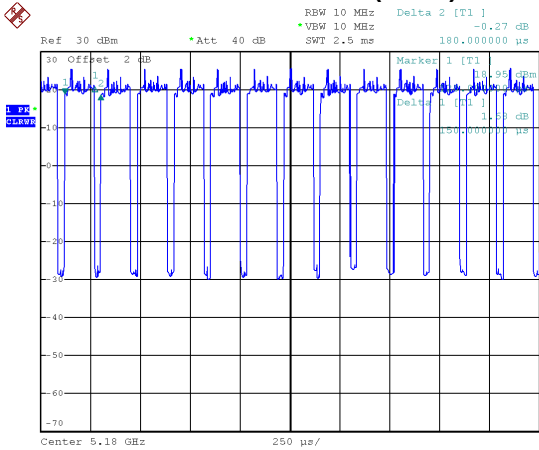

Date: 28.JUL.2020 11:53:53

Duty cycle = 0.150 ms / 0.180 ms = 83.33%
 Duty Factor = 10 * log(1 / Duty cycle) = 0.79dB

IEEE 802.11ac (VHT80)

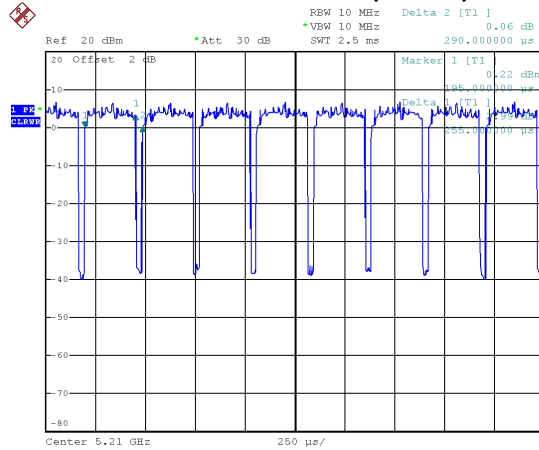

Date: 21.JUL.2020 12:33:50

Duty cycle = 0.255 ms / 0.290 ms = 87.93%
 Duty Factor = 10 * log(1 / Duty cycle) = 0.56 dB

IEEE 802.11ax (HE40)

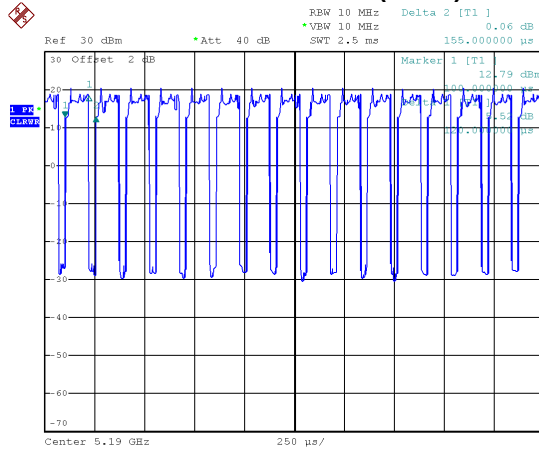

Date: 28.JUL.2020 11:54:34

Duty cycle = 0.120 ms / 0.155 ms = 77.42%
 Duty Factor = 10 * log(1 / Duty cycle) = 1.11 dB

IEEE 802.11ax (HE80)

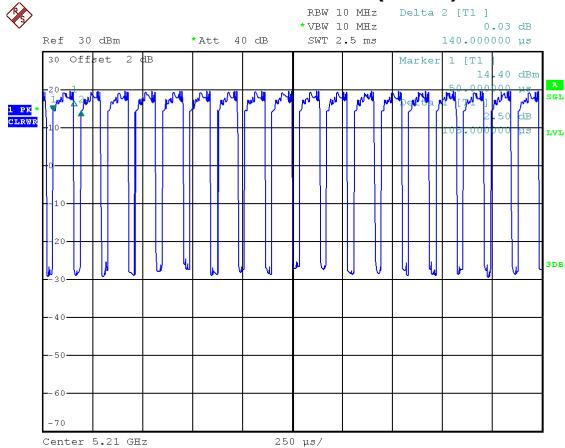

Date: 28.JUL.2020 11:57:49

Duty cycle = $0.105 \text{ ms} / 0.140 \text{ ms} = 75.00\%$
 Duty Factor = $10 * \log(1 / \text{Duty cycle}) = 1.25 \text{ dB}$

NOTE:

- For IEEE 802.11a, IEEE 802.11n (HT20) and IEEE 802.11ac (VHT20):
 For radiated emissions frequency above 1 GHz, the resolution bandwidth of test receiver/spectrum analyzer is 1 MHz and the video bandwidth is 1 kHz (Duty cycle < 98%).
- For IEEE 802.11n (HT40) and IEEE 802.11ac (VHT40):
 For radiated emissions frequency above 1 GHz, the resolution bandwidth of test receiver/spectrum analyzer is 1 MHz and the video bandwidth is 2 kHz (Duty cycle < 98%).
- For IEEE 802.11ac (VHT80):
 For radiated emissions frequency above 1 GHz, the resolution bandwidth of test receiver/spectrum analyzer is 1 MHz and the video bandwidth is 3 kHz (Duty cycle < 98%).
- For IEEE 802.11ax (HE20):
 For radiated emissions frequency above 1 GHz, the resolution bandwidth of test receiver/spectrum analyzer is 1 MHz and the video bandwidth is 4 kHz (Duty cycle < 98%).
- For IEEE 802.11ax (HE40):
 For radiated emissions frequency above 1 GHz, the resolution bandwidth of test receiver/spectrum analyzer is 1 MHz and the video bandwidth is 9 kHz (Duty cycle < 98%).
- For IEEE 802.11ax (HE80):
 For radiated emissions frequency above 1 GHz, the resolution bandwidth of test receiver/spectrum analyzer is 1 MHz and the video bandwidth is 10 kHz (Duty cycle < 98%).

2.5 BLOCK DIAGRAM SHOWING THE CONFIGURATION OF SYSTEM TESTED

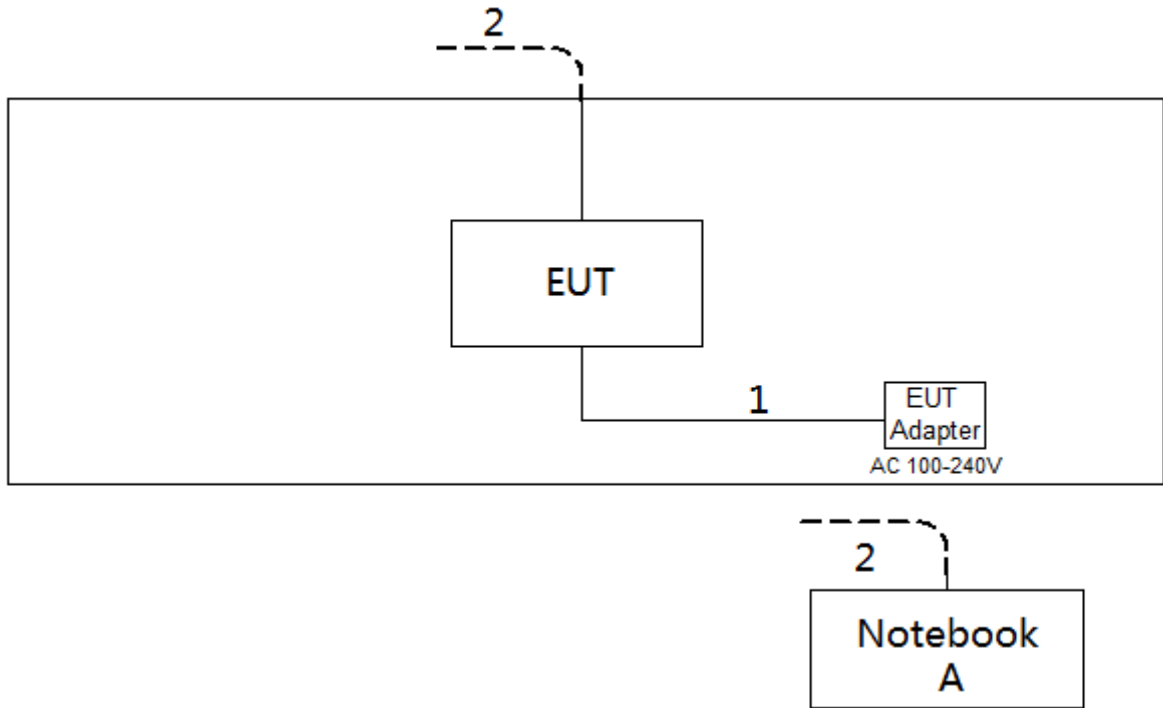

2.6 SUPPORT UNITS

Item	Equipment	Brand	Model No.	Series No.
A	Notebook	Lenovo	#P152014	N/A

Item	Cable Type	Shielded Type	Ferrite Core	Length
1	DC Cable	NO	NO	1.5m
2	RJ45 Cable	NO	NO	10m

3. AC POWER LINE CONDUCTED EMISSIONS TEST

3.1 LIMIT

Frequency (MHz)	Limit (dBµV)	
	Quasi-peak	Average
0.15 - 0.5	66 to 56*	56 to 46*
0.50 - 5.0	56	46
5.0 - 30.0	60	50

NOTE:

- (1) The tighter limit applies at the band edges.
- (2) The limit of " * " marked band means the limitation decreases linearly with the logarithm of the frequency in the range.

The following table is the setting of the receiver

Receiver Parameter	Setting
Attenuation	10 dB
Start Frequency	0.15 MHz
Stop Frequency	30 MHz
IF Bandwidth	9 KHz

3.2 TEST PROCEDURE

- a. The EUT was placed 0.8 meters from the horizontal ground plane with EUT being connected to the power mains through a line impedance stabilization network (LISN). All other support equipment powered from additional LISN(s). The LISN provide 50 Ohm/ 50uH of coupling impedance for the measuring instrument.
- b. Interconnecting cables that hang closer than 40 cm to the ground plane shall be folded back and forth in the center forming a bundle 30 to 40 cm long.
- c. I/O cables that are not connected to a peripheral shall be bundled in the center. The end of the cable may be terminated, if required, using the correct terminating impedance. The overall length shall not exceed 1 m.
- d. LISN at least 80 cm from nearest part of EUT chassis.
- e. For the actual test configuration, please refer to the related Item -EUT Test Photos.

3.3 DEVIATION FROM TEST STANDARD

No deviation

3.4 TEST SETUP

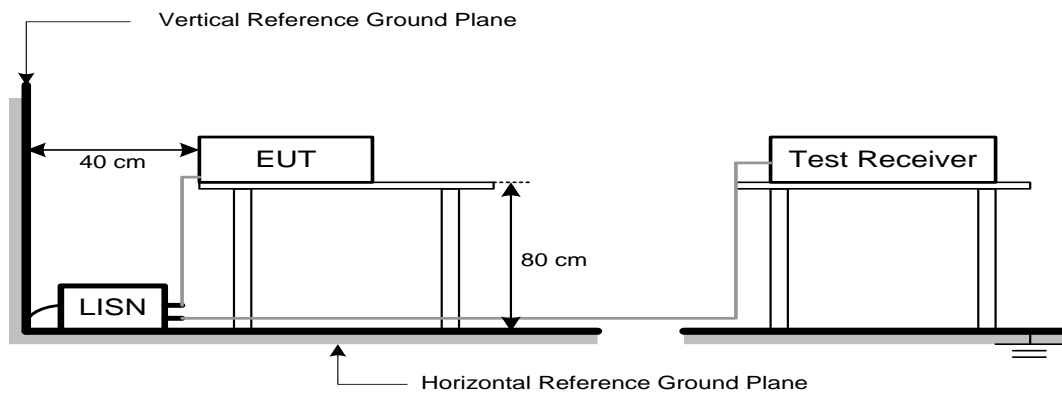

3.5 EUT OPERATION CONDITIONS

The EUT was configured for testing in a typical fashion (as a customer would normally use it). The EUT has been programmed to continuously transmit during test. This operating condition was tested and used to collect the included data.

The EUT was programmed to be in continuously transmitting/TX mode.

3.6 TEST RESULTS

Please refer to the APPENDIX A.

4. RADIATED EMISSIONS TEST

4.1 LIMIT

In case the emission fall within the restricted band specified on 15.205(a), then the 15.209(a) limit in the table below has to be followed.

LIMITS OF RADIATED EMISSIONS MEASUREMENT (9 kHz to 1000 MHz)

Frequency (MHz)	Field Strength (microvolts/meter)	Measurement Distance (meters)
0.009-0.490	2400/F(kHz)	300
0.490-1.705	24000/F(kHz)	30
1.705-30.0	30	30
30-88	100	3
88-216	150	3
216-960	200	3
Above 960	500	3

LIMITS OF UNWANTED EMISSION OUT OF THE RESTRICTED BANDS

Frequency (MHz)	EIRP Limit (dBm/MHz)	Equivalent Field Strength at 3m (dBμV/m)
5150-5250	-27	68.3
5250-5350	-27	68.3
5470-5725	-27	68.3
5725-5850	-27 NOTE (2)	68.3
	10 NOTE (2)	105.3
	15.6 NOTE (2)	110.9
	27 NOTE (2)	122.3

NOTE:

- (1) The following formula is used to convert the equipment isotropic radiated power (eirp) to field strength:

$$E = \frac{1000000\sqrt{30P}}{3} \mu\text{V/m, where P is the eirp (Watts)}$$

- (2) According to 15.407(b)(4)(i), all emissions shall be limited to a level of -27 dBm/MHz at 75 MHz or more above or below the band edge increasing linearly to 10 dBm/MHz at 25 MHz above or below the band edge, and from 25 MHz above or below the band edge increasing linearly to a level of 15.6 dBm/MHz at 5 MHz above or below the band edge, and from 5 MHz above or below the band edge increasing linearly to a level of 27 dBm/MHz at the band edge.

4.2 TEST PROCEDURE

- a. The measuring distance of 3 m shall be used for measurements. The EUT was placed on the top of a rotating table 0.8 meter above the ground at a 3 meter semi-anechoic chamber. The table was rotated 360 degrees to determine the position of the highest radiation.(below 1GHz)
- b. The measuring distance of 3 m shall be used for measurements. The EUT was placed on the top of a rotating table 1.5 meter above the ground at a 3 meter semi-anechoic chamber. The table was rotated 360 degrees to determine the position of the highest radiation.(above 1GHz)
- c. The height of the equipment or of the substitution antenna shall be 0.8m or 1.5m; the height of the test antenna shall vary between 1 m to 4 m. Both horizontal and vertical polarizations of the antenna are set to make the measurement.
- d. For each suspected emission, the EUT was arranged to its worst case and then the antenna was tuned to heights find the maximum reading (used Bore sight function).
- e. The receiver system was set to peak and average detect function and specified bandwidth with maximum hold mode when the test frequency is above 1 GHz.
- f. The initial step in collecting radiated emission data is a receiver peak detector mode pre-scanning the measurement frequency range. Significant peaks are then marked and then Quasi Peak detector mode re-measured.
- g. All readings are Peak unless otherwise stated QP in column of Note. Peak denotes that the Peak reading compliance with the QP Limits and then QP Mode measurement didn't perform.
(below 1 GHz)
- h. All readings are Peak Mode value unless otherwise stated AVG in column of Note. If the Peak Mode Measured value compliance with the Peak Limits and lower than AVG Limits, the EUT shall be deemed to meet both Peak & AVG Limits and then only Peak Mode was measured, but AVG Mode didn't perform. (above 1 GHz)
- i. For the actual test configuration, please refer to the related Item –EUT Test Photos.

4.3 DEVIATION FROM TEST STANDARD

No deviation

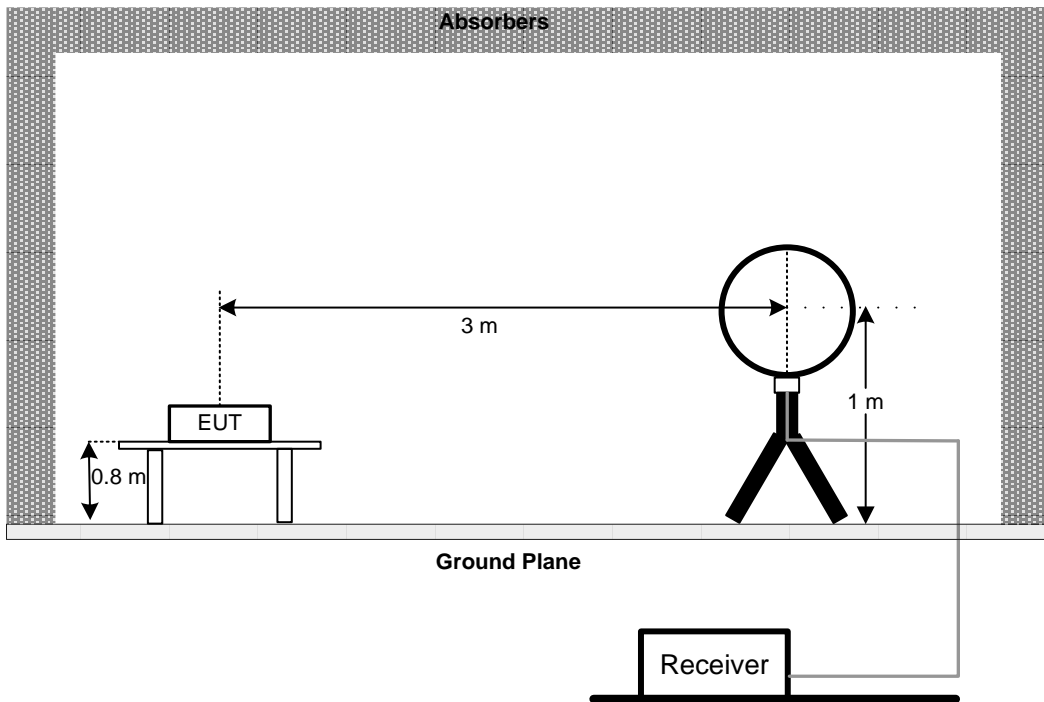
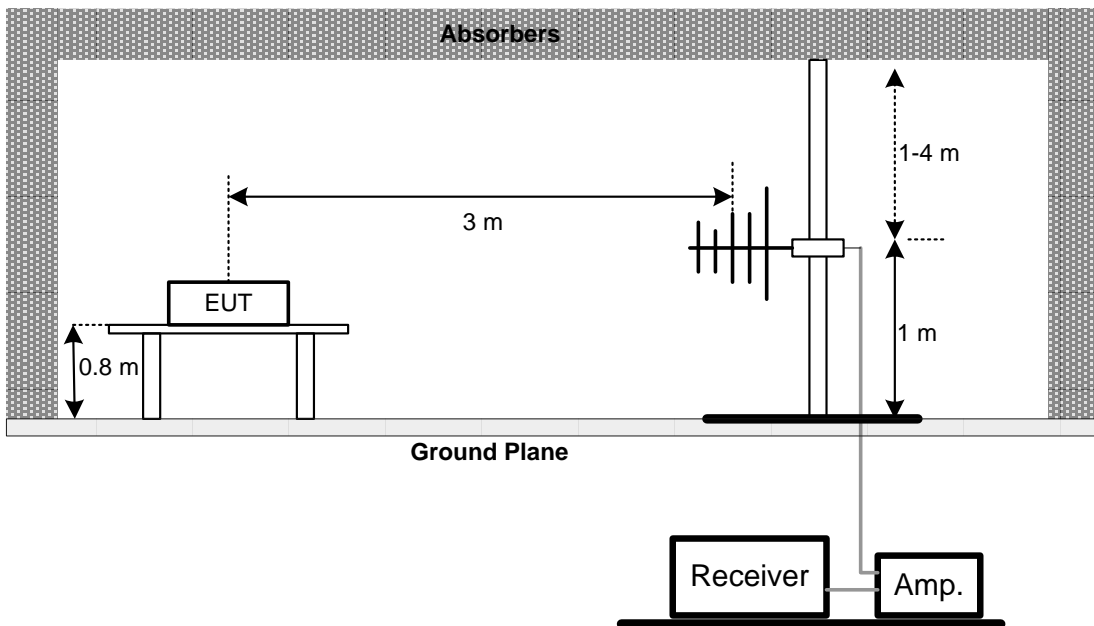
4.4 TEST SETUP**9 kHz to 30 MHz****30 MHz to 1 GHz**

Above 1 GHz

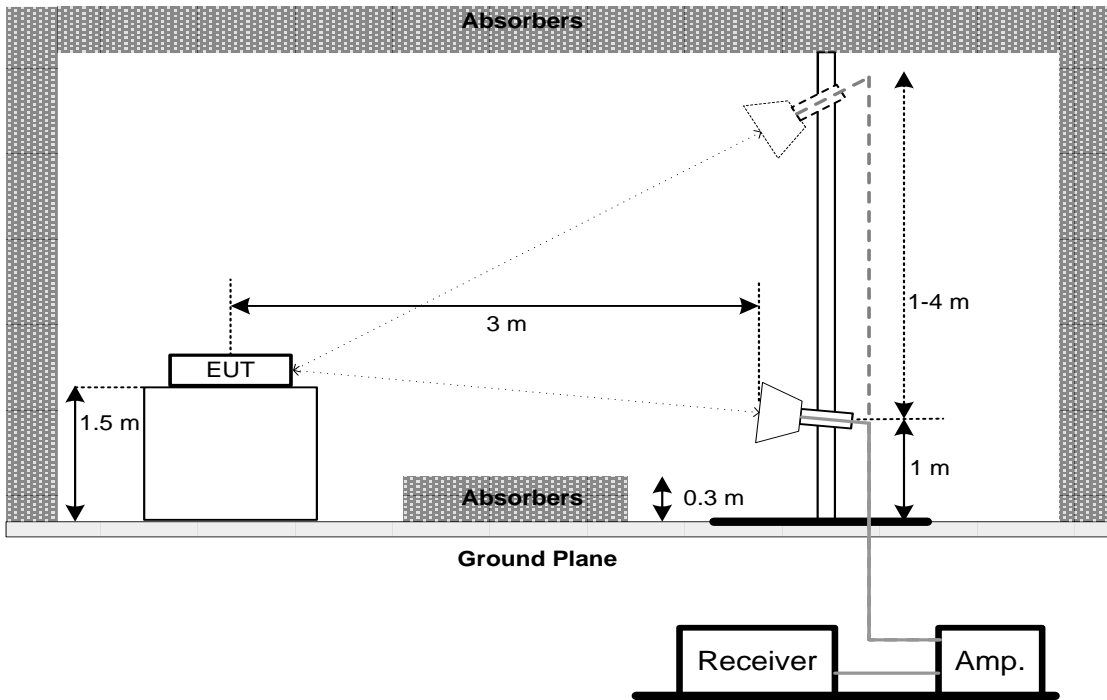

**Above 1 GHz
Band edge**

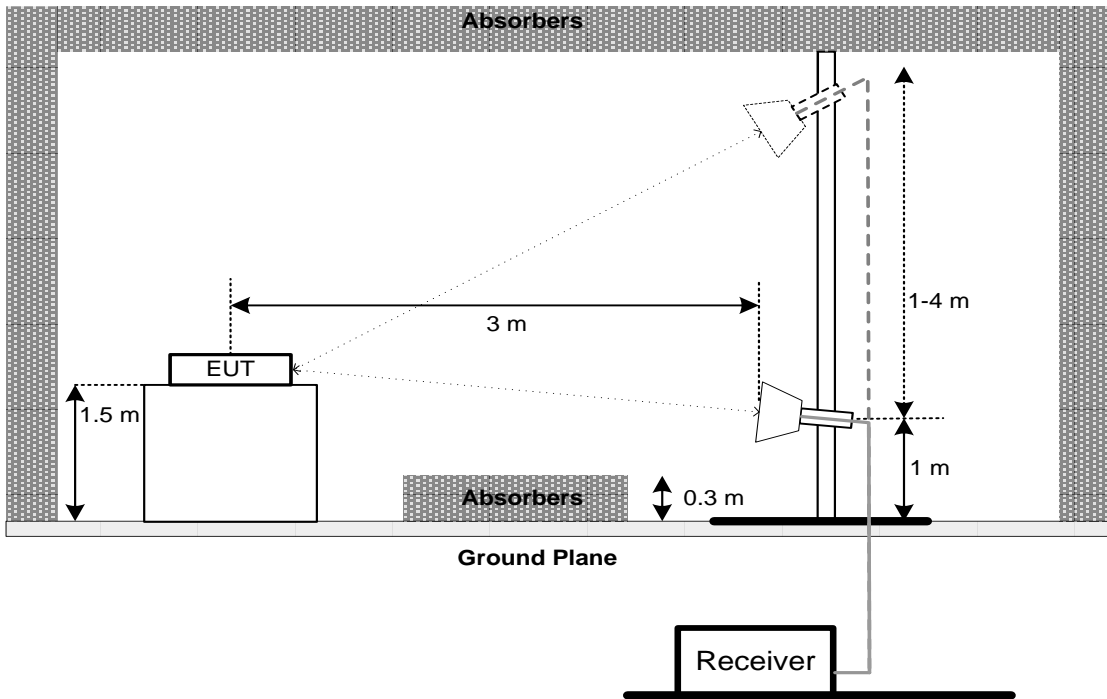

4.5 EUT OPERATION CONDITIONS

The EUT tested system was configured as the statements of 3.5 unless otherwise a special operating condition is specified in the follows during the testing.

4.6 TEST RESULTS - 9 KHZ to 30 MHZ

Please refer to the APPENDIX B

Remark:

- (1) The amplitude of spurious emissions which are attenuated by more than 20 dB below the permissible value has no need to be reported.
- (2) Distance extrapolation factor = $40 \log (\text{specific distance} / \text{test distance})$ (dB).
- (3) Limit line = specific limits (dBuV) + distance extrapolation factor.

4.7 TEST RESULTS - 30 MHz TO 1000 MHz

Please refer to the APPENDIX C.

4.8 TEST RESULTS - ABOVE 1000 MHz

Please refer to the APPENDIX D.

Remark:

- (1) No limit: This is fundamental signal, the judgment is not applicable.
For fundamental signal judgment was referred to Peak output test.

5. BANDWIDTH TEST

5.1 LIMIT

FCC Part15, Subpart E (15.407)			
Section	Test Item	Limit	Frequency Range (MHz)
15.407(a) 15.407(e)	26 dB Bandwidth	-	5150-5250
	26 dB Bandwidth	-	5250-5350
	26 dB Bandwidth	-	5470-5725
	6 dB Bandwidth	Minimum 500 kHz	5725-5850

5.2 TEST PROCEDURE

- a. The EUT was directly connected to the spectrum analyzer and antenna output port as show in the block diagram below
- b. a. Spectrum Setting:
For UNII-2A, UNII-2A, UNII-2C:

Spectrum Parameter	Setting
Attenuation	Auto
Span Frequency	> 26 dB Bandwidth
RBW	300 kHz (Bandwidth 20 MHz) 1 MHz (Bandwidth 40 MHz and 80 MHz)
VBW	1 MHz (Bandwidth 20 MHz) 3 MHz (Bandwidth 40 MHz and 80 MHz)
Detector	Peak
Trace	Max Hold
Sweep Time	Auto

For UNII-2C:

Spectrum Parameter	Setting
Attenuation	Auto
Span Frequency	6 dB Bandwidth
RBW	100 kHz
VBW	300 kHz
Detector	Peak
Trace	Max Hold
Sweep Time	Auto

- c. Measured the spectrum width with power higher than 26 dB below carrier

5.3 TEST PROCEDURE

No deviation.

5.4 TEST SETUP**5.5 EUT OPERATION CONDITIONS**

The EUT was programmed to be in continuously transmitting mode.

5.6 TEST RESULTS

Please refer to the APPENDIX E.

6. MAXIMUM OUTPUT POWER TEST

6.1 LIMIT

FCC Part15, Subpart E (15.407)			
Section	Test Item	Limit	Frequency Range (MHz)
15.407(a)	Conducted Output Power	AP device: 1 Watt (30 dBm) Client device: 250 mW (24 dBm)	5150-5250
		250 mW (24 dBm)	5250-5350
		250 mW (24 dBm)	5470-5725
		1 Watt (30dBm)	5725-5850

Note:

For the 5.25-5.35 GHz and 5.47-5.725 GHz bands, the maximum conducted output power over the frequency bands of operation shall not exceed the lesser of 250 mW or 11 dBm + 10log B, where B is the 26dB Bandwidth in megahertz.

6.2 TEST PROCEDURE

- a. The EUT was directly connected to the power meter and antenna output port as show in the block diagram below.
- b. Test test was performed in accordance with method of FCC KDB 789033 D02 General UNII Test Procedures New Rules v02r01.

6.3 DEVIATION FROM STANDARD

No deviation.

6.4 TEST SETUP

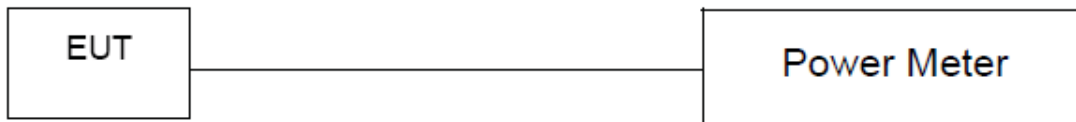

6.5 EUT OPERATION CONDITIONS

The EUT was programmed to be in continuously transmitting mode.

6.6 TEST RESULTS

Please refer to the APPENDIX F.

7. POWER SPECTRAL DENSITY TEST

7.1 LIMIT

FCC Part15, Subpart E (15.407)			
Section	Test Item	Limit	Frequency Range (MHz)
15.407(a)	Power Spectral Density	AP device: 17 dBm/MHz Client device: 11 dBm/MHz	5150-5250
		11 dBm/MHz	5250-5350
		11 dBm/MHz	5470-5725
		30 dBm/500 kHz	5725-5850

7.2 TEST PROCEDURE

- a. The EUT was directly connected to the spectrum analyzer and antenna output port as show in the block diagram below.
- b. Spectrum Setting

Spectrum Parameter	Setting
Attenuation	Auto
Span Frequency	Encompass the entire emissions bandwidth (EBW) of the signal
RBW	= 1 MHz.
VBW	≥ 3 MHz.
Detector	RMS
Trace average	100 trace
Sweep Time	Auto

Note:

1. The value measured with RBW=1 MHz is to be added with $10\log(500 \text{ kHz}/1 \text{ MHz})$ which is -3 dB. For example, if the measured value is +10dBm using RBW=1 MHz (that is +10 dBm/MHz), then the converted value will be +7dBm/500kHz.

7.3 DEVIATION FROM STANDARD

No deviation.

7.4 TEST SETUP



7.5 EUT OPERATION CONDITIONS

The EUT was programmed to be in continuously transmitting mode.

7.6 TEST RESULTS

Please refer to the APPENDIX G.

8. FREQUENCY STABILITY MEASUREMENT

8.1 LIMIT

FCC Part15, Subpart E (15.407)			
Section	Test Item	Limit	Frequency Range (MHz)
15.407(g)	Frequency Stability	An emission is maintained within the band of operation under all conditions of normal operation as specified in the users manual.	5150-5250
			5250-5350
			5470-5725
			5725-5850

8.2 TEST PROCEDURE

- a. The EUT was directly connected to the spectrum analyzer and antenna output port as show in the block diagram below.
- b. Spectrum Setting:

Spectrum Parameter	Setting
Attenuation	Auto
Span Frequency	Entire absence of modulation emissions bandwidth
RBW	10 kHz
VBW	10 kHz
Sweep Time	Auto

- c. The test extreme voltage is to change the primary supply voltage from 85 to 115 percent of the nominal value.
- d. User manual temperature is 0°C~40°C.

8.3 DEVIATION FROM STANDARD

No deviation.

8.4 TEST SETUP

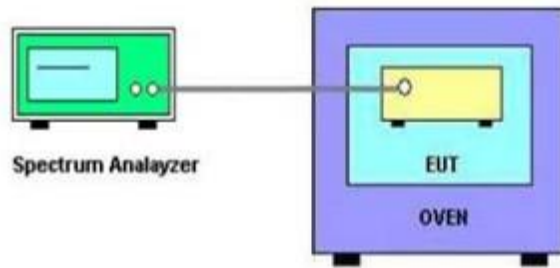

8.5 EUT OPERATION CONDITIONS

The EUT was programmed to be in continuously transmitting mode.

8.6 TEST RESULTS

Please refer to the APPENDIX H.

9. MEASUREMENT INSTRUMENTS LIST

AC Power Line Conducted Emissions					
Item	Kind of Equipment	Manufacturer	Type No.	Serial No.	Calibrated until
1	Line Impedance Stabilisation Network	Schwarzbeck	NNLK 8121	8121-822	Mar. 21, 2021
2	TWO-LINE V-NETWORK	R&S	ENV216	101340	Aug. 23, 2021
3	EMI Test Receiver	R&S	ESCI	100082	Mar. 28, 2021
4	50Ω coaxial switch	Anritsu	MP59B	6201750902	Mar. 21, 2021
5	Cable	10m	EMCRG400-BM-NM-10000	170628	Mar. 21, 2021
6	Measurement Software	Farad	EZ-EMC Ver.NB-03A1-01	N/A	N/A

Radiated Emissions - 9 kHz to 30 MHz					
Item	Kind of Equipment	Manufacturer	Type No.	Serial No.	Calibrated until
1	Loop Antenna	EMCI	EMCI LPA600	275	Mar. 28, 2021
2	Cable	N/A	EMCRG400-BM-NM-10000	170628	Mar. 21, 2021
3	MXE EMI Receiver	Keysight	N9038A	MY57150106	Mar. 28, 2021
4	Measurement Software	Farad	EZ-EMC Ver.BTL-2ANT-1	N/A	N/A

Radiated Emissions - 30 MHz to 1 GHz					
Item	Kind of Equipment	Manufacturer	Type No.	Serial No.	Calibrated until
1	TRILOG Broadband Antenna	Schwarzbeck	VULB 9168	719	Mar. 28, 2021
2	Pre-Amplifier	emci	EMC9135	980400	Mar. 21, 2021
3	MXE EMI Receiver	Keysight	N9038A	MY57150106	Mar. 21, 2021
4	Attenuator	emci	EMCI-N-6-06	AT-N0644	Mar. 21, 2021
5	Cable	7m	EMC104-SM-SM-7000	170330	Apr. 16, 2021
6	Cable	1m	EMC104-SM-SM-1000	170331	Apr. 16, 2021
7	Cable	3.5m	EMC104-SM-NM-3500	170621	Apr. 16, 2021
8	Measurement Software	Farad	EZ-EMC Ver.BTL-2ANT-1	N/A	N/A

Radiated Emissions - Above 1 GHz					
Item	Kind of Equipment	Manufacturer	Type No.	Serial No.	Calibrated until
1	Double-Ridged Waveguide Horn Antenna	Schwarzbeck	BBHA 9120D	9120D-1787	Mar. 28, 2021
2	Double-Ridged Waveguide Horn Antenna	ETS-Lindgren	3116C	00203919	Mar. 28, 2021
3	Pre-Amplifier	emci	EMC012645SE	980421	Mar. 21, 2021
4	Pre-Amplifier	emci	EMC184045SE	980409	Apr. 16, 2021
5	EXA Spectrum Analyzer	Keysight	N9010A	MY56480559	Apr. 16, 2021
6	MXE EMI Receiver	Keysight	N9038A	MY56400088	Apr. 16, 2021
7	Cable	7m	EMC104-SM-SM-700 0	170330	N/A
8	Cable	1m	EMC104-SM-SM-100 0	170331	Mar. 28, 2021
9	Cable	3.5m	EMC104-SM-NM-350 0	170621	Apr. 02, 2021
10	Cable	0.8m	EMC102-SM-SM-800	170335	Mar. 21, 2021
11	Cable	6m	EMC102-SM-SM-600 0	170336	Mar. 21, 2021
12	Measurement Software	Farad	EZ-EMC Ver.NB-03A1-01	N/A	Apr. 13, 2021

Bandwidth					
Item	Kind of Equipment	Manufacturer	Type No.	Serial No.	Calibrated until
1	Spectrum Analyzer	R&S	FSP40	100626	Mar. 21, 2021

Conducted Output Power					
Item	Kind of Equipment	Manufacturer	Type No.	Serial No.	Calibrated until
1	Spectrum Analyzer	R&S	FSP40	100626	Mar. 21, 2021

Power Spectral Density					
Item	Kind of Equipment	Manufacturer	Type No.	Serial No.	Calibrated until
1	Spectrum Analyzer	R&S	FSP40	100626	Mar. 21, 2021

Remark: "N/A" denotes no model name, serial no. or calibration specified.

All calibration period of equipment list is one year.

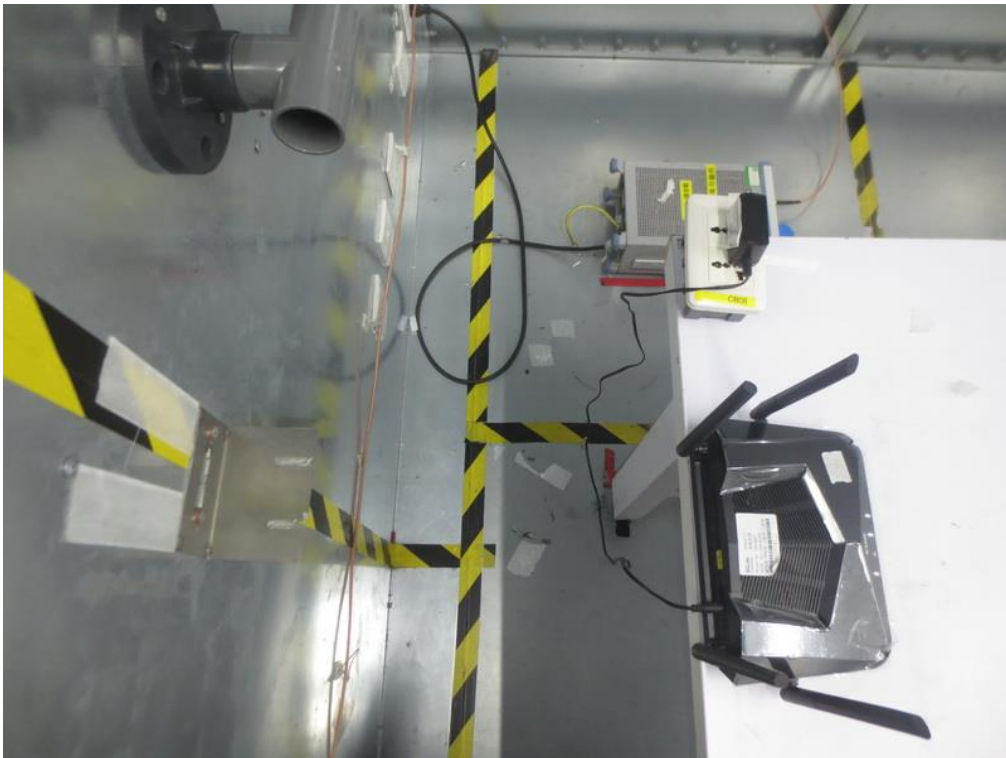
10. EUT TEST PHOTOS**Conducted Emissions Test Photos**

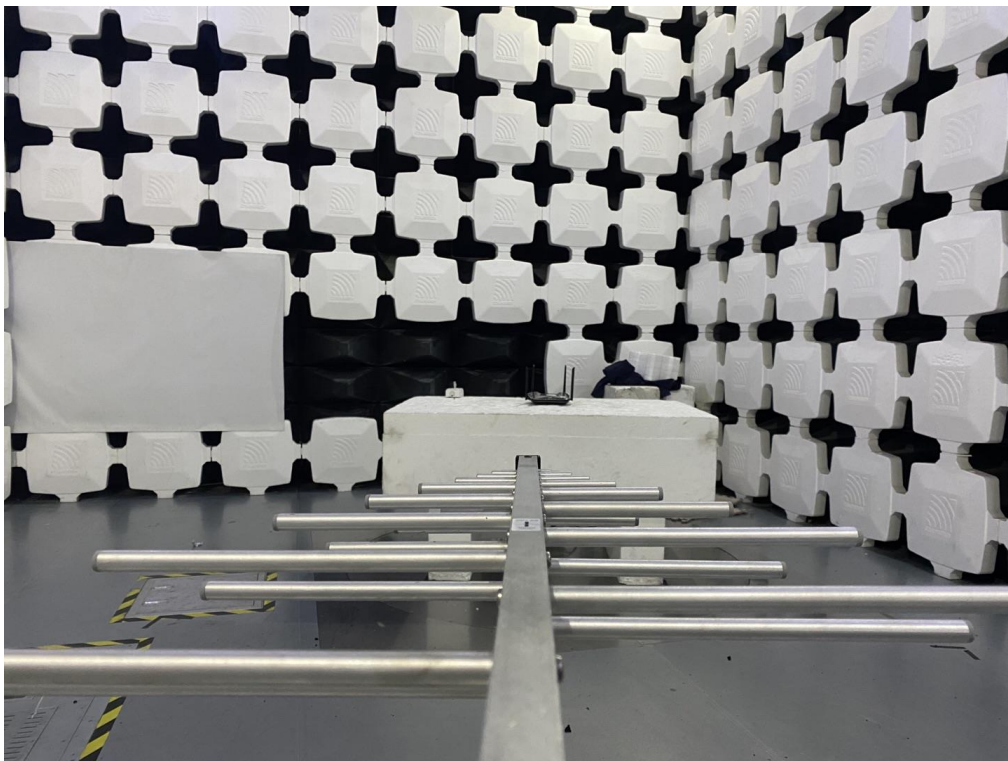
Radiated Emissions Test Photos**30 MHz to 1 GHz**

Radiated Emissions Test Photos

Above 1 GHz

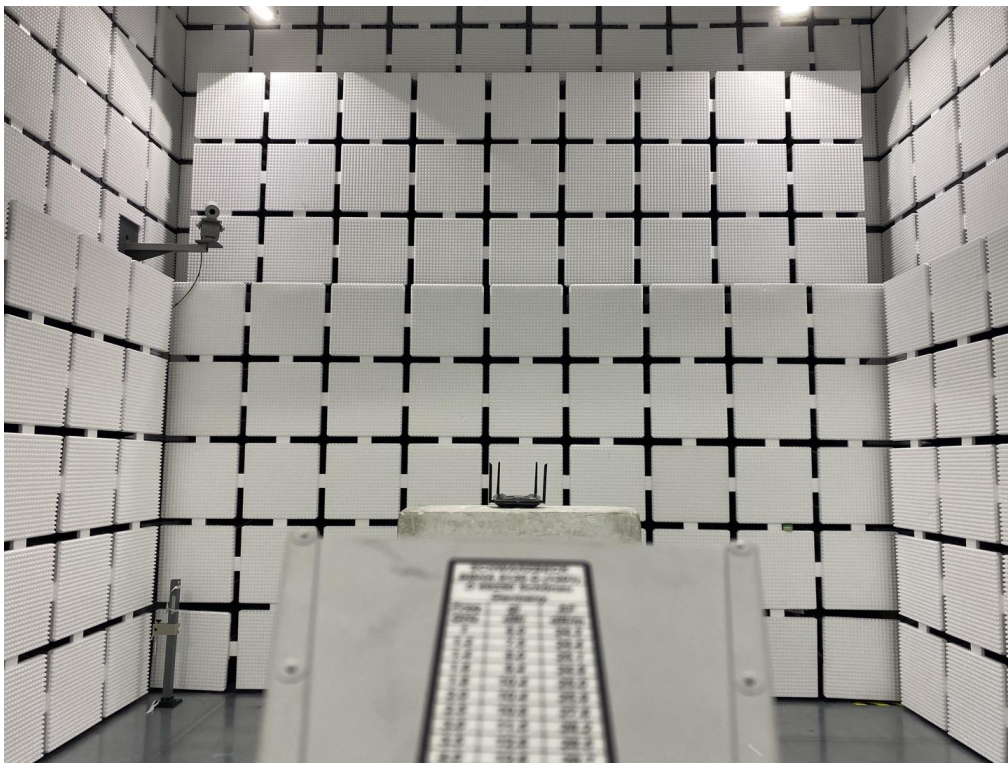
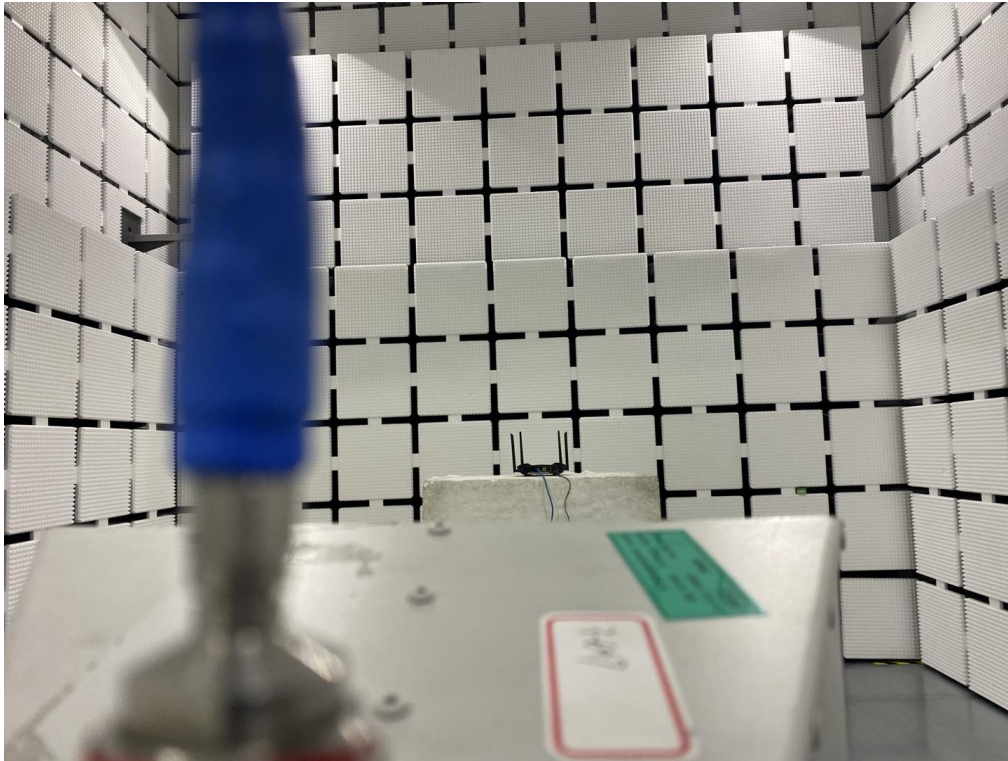

APPENDIX A - AC POWER LINE CONDUCTED EMISSIONS

Test Mode: TX AC80 MODE CHANNEL 58

Line

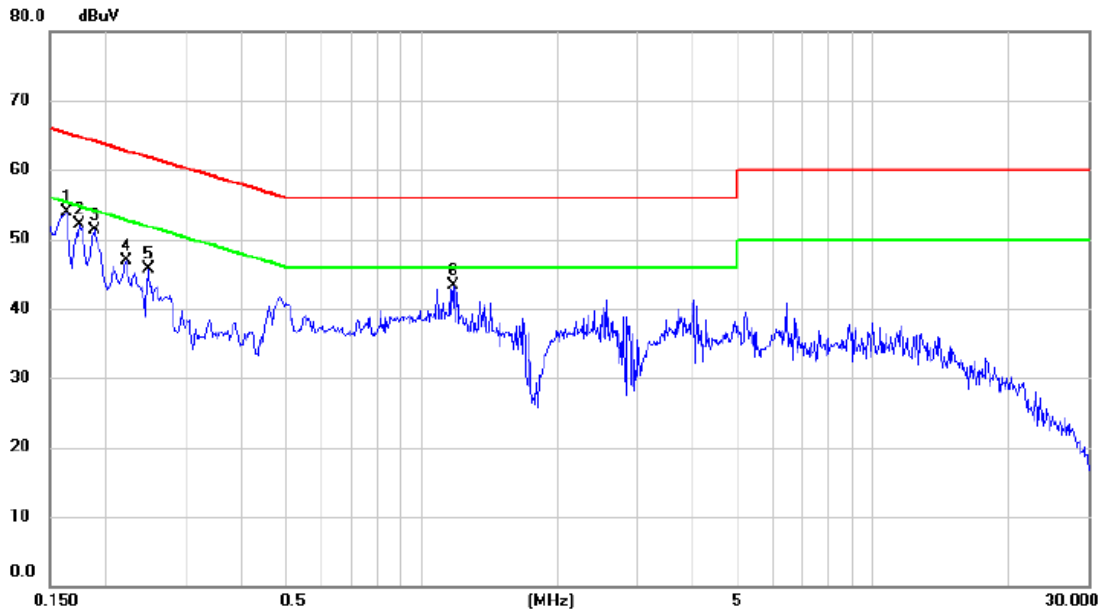

No.	Mk.	Freq. MHz	Reading Level dBuV	Correct Factor dB	Measure- ment dBuV	Limit dBuV	Margin dB	Detector	Comment
1	*	0.1635	44.08	9.74	53.82	65.28	-11.46	peak	
2		0.1740	42.38	9.75	52.13	64.77	-12.64	peak	
3		0.1892	41.57	9.77	51.34	64.07	-12.73	peak	
4		0.2220	37.06	9.79	46.85	62.74	-15.89	peak	
5		0.2490	35.89	9.79	45.68	61.79	-16.11	peak	
6		1.1801	33.54	9.75	43.29	56.00	-12.71	peak	

REMARKS:

- (1) Measurement Value = Reading Level + Correct Factor.
- (2) Margin Level = Measurement Value - Limit Value.

Test Mode: TX AC80 MODE CHANNEL 58

Neutral

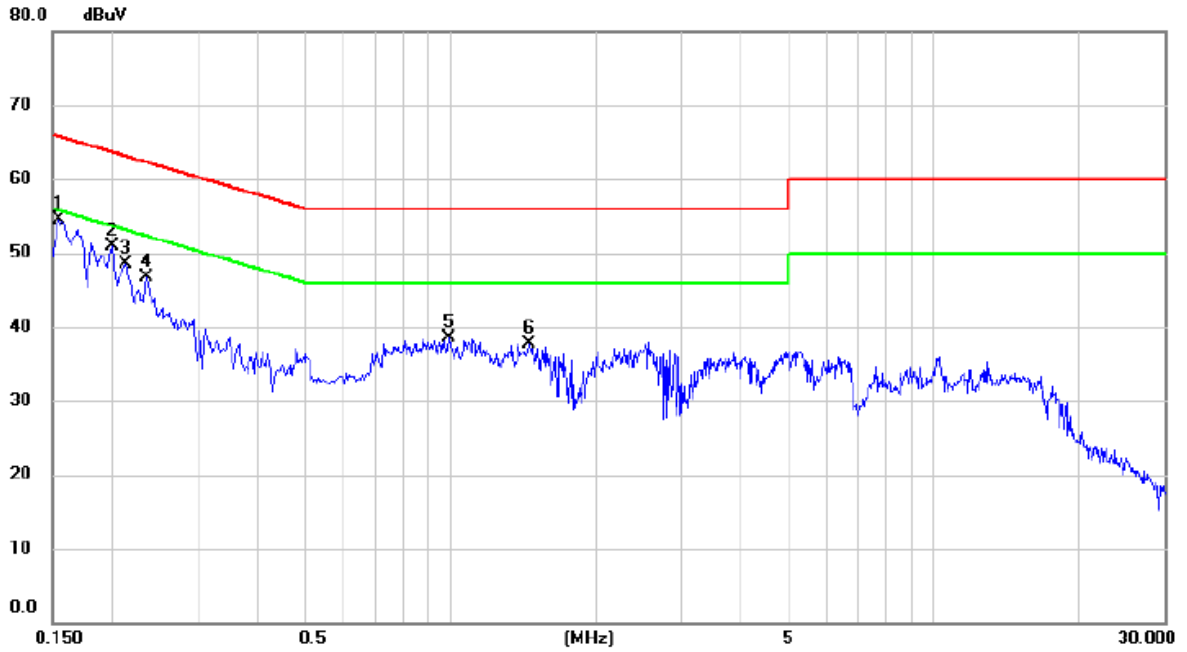

No.	Mk.	Freq. MHz	Reading Level dBuV	Correct Factor dB	Measure- ment dBuV	Limit dBuV	Margin dB	Detector	Comment
1	*	0.1544	44.84	9.61	54.45	65.76	-11.31	peak	
2		0.1995	41.32	9.63	50.95	63.63	-12.68	peak	
3		0.2130	38.79	9.63	48.42	63.09	-14.67	peak	
4		0.2353	37.01	9.63	46.64	62.26	-15.62	peak	
5		0.9960	28.79	9.72	38.51	56.00	-17.49	peak	
6		1.4501	27.96	9.75	37.71	56.00	-18.29	peak	

REMARKS:

(1) Measurement Value = Reading Level + Correct Factor.

(2) Margin Level = Measurement Value - Limit Value.

APPENDIX B - RADIATED EMISSION - 9 KHZ TO 30 MHZ

Note: The measured value have enough margin over 20dB than the limit, therefore they are not reported.

APPENDIX C - RADIATED EMISSION - 30 MHZ TO 1 GHZ

Test Mode: TX AC80 MODE CHANNEL 58

Vertical

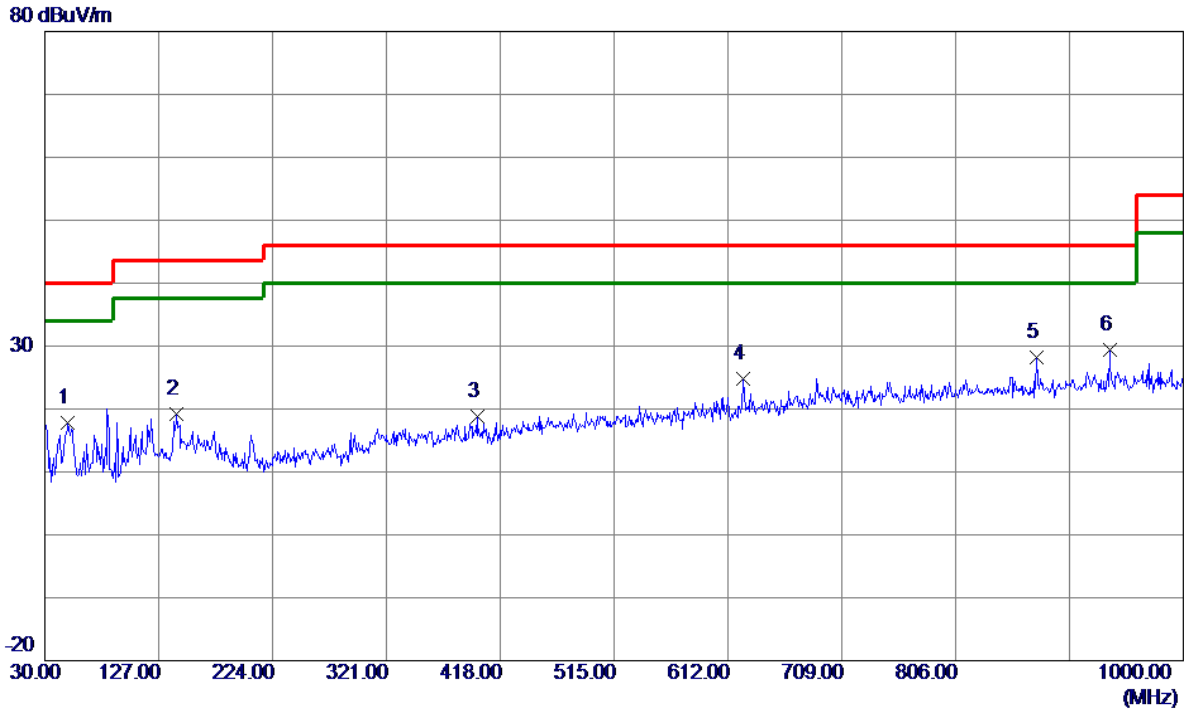

No.	Freq. MHz	Reading Level dBuV/m	Correct Factor dB	Measure ment dBuV/m	Limit dBuV/m	Margin dB	Detector	Comment
1	49.8849	34.96	-17.24	17.72	40.00	-22.28	Peak	
2	142.5200	36.70	-17.54	19.16	43.50	-24.34	Peak	
3	398.1150	33.65	-14.89	18.76	46.00	-27.24	Peak	
4	625.0949	35.52	-10.71	24.81	46.00	-21.19	Peak	
5	874.8700	36.42	-8.17	28.25	46.00	-17.75	Peak	
6 *	937.4350	36.69	-7.34	29.35	46.00	-16.65	Peak	

REMARKS:

- (1) Measurement Value = Reading Level + Correct Factor.
- (2) Margin Level = Measurement Value - Limit Value.

Test Mode: TX AC80 MODE CHANNEL 58

Horizontal

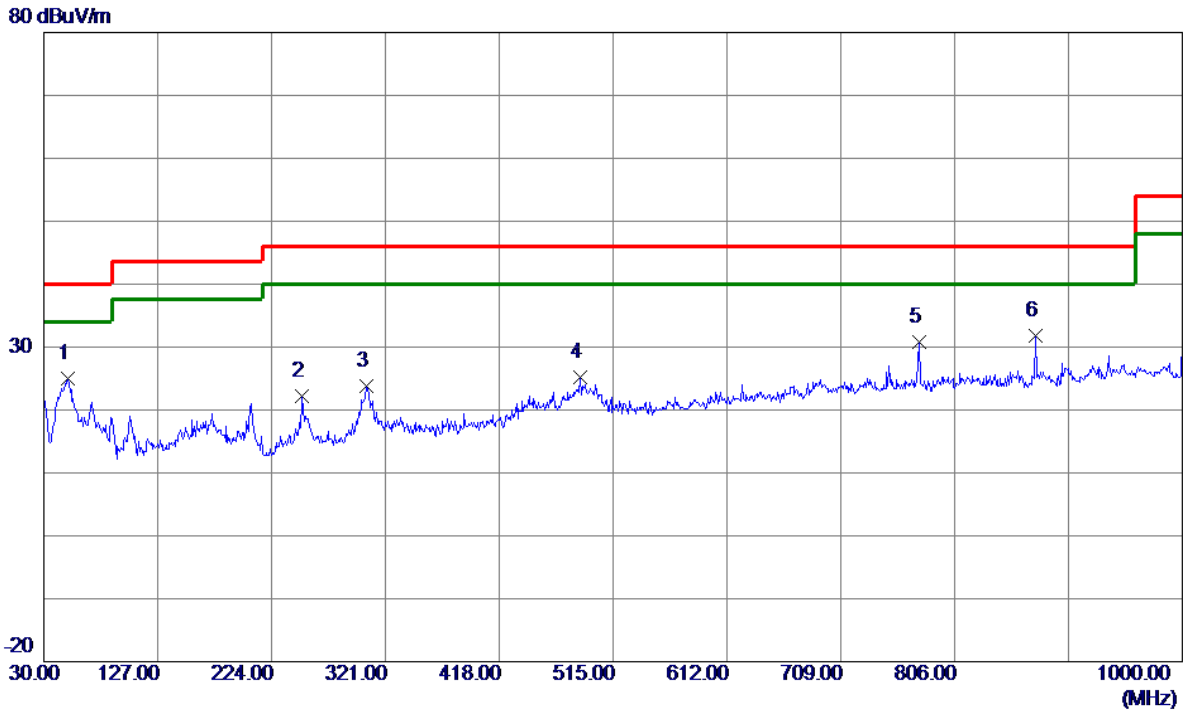

No.	Freq. MHz	Reading Level dBuV/m	Correct Factor dB	Measure ment dBuV/m	Limit dBuV/m	Margin dB	Detector	Comment
1	50.8550	42.29	-17.27	25.02	40.00	-14.98	Peak	
2	250.1900	40.75	-18.51	22.24	46.00	-23.76	Peak	
3	304.9950	40.53	-16.80	23.73	46.00	-22.27	Peak	
4	487.3550	38.36	-13.13	25.23	46.00	-20.77	Peak	
5	775.4450	39.50	-8.78	30.72	46.00	-15.28	Peak	
6 *	874.8700	40.01	-8.17	31.84	46.00	-14.16	Peak	

REMARKS:

- (1) Measurement Value = Reading Level + Correct Factor.
- (2) Margin Level = Measurement Value - Limit Value.

APPENDIX D - RADIATED EMISSION - ABOVE 1000 MHZ

Orthogonal Axis	X
Test Mode	UNII-2A_TX A Mode 5260 MHz

Vertical

130 dBuV/m

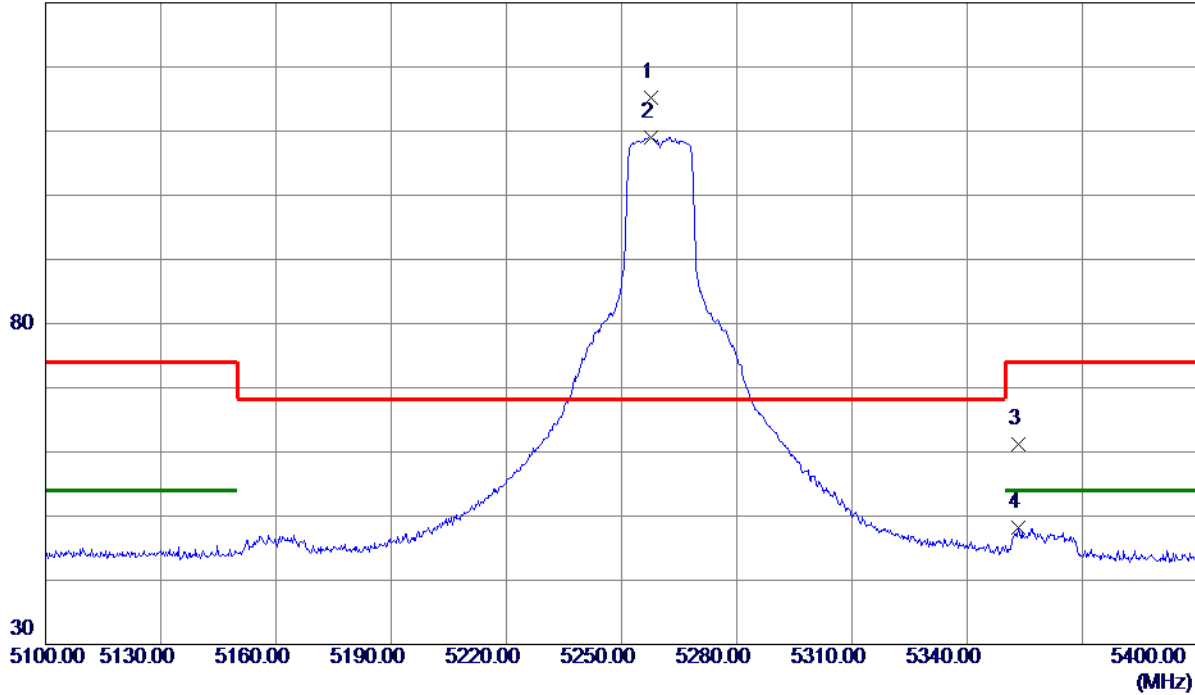

No.	Freq. MHz	Reading Level dBuV/m	Correct Factor dB	Measure ment dBuV/m	Limit dBuV/m	Margin dB	Detector	Comment
1 *	5257.6500	77.52	37.60	115.12	68.30	46.82	Peak	
2	5257.6500	71.46	37.60	109.06	999.00	-889.94	AVG	
3	5353.3500	23.44	37.75	61.19	74.00	-12.81	Peak	
4	5353.3500	10.38	37.75	48.13	54.00	-5.87	AVG	

REMARKS:

- (1) Measurement Value = Reading Level + Correct Factor.
- (2) Margin Level = Measurement Value - Limit Value.

Orthogonal Axis	X
Test Mode	UNII-2A_TX A Mode 5260 MHz

Vertical

80 dBuV/m

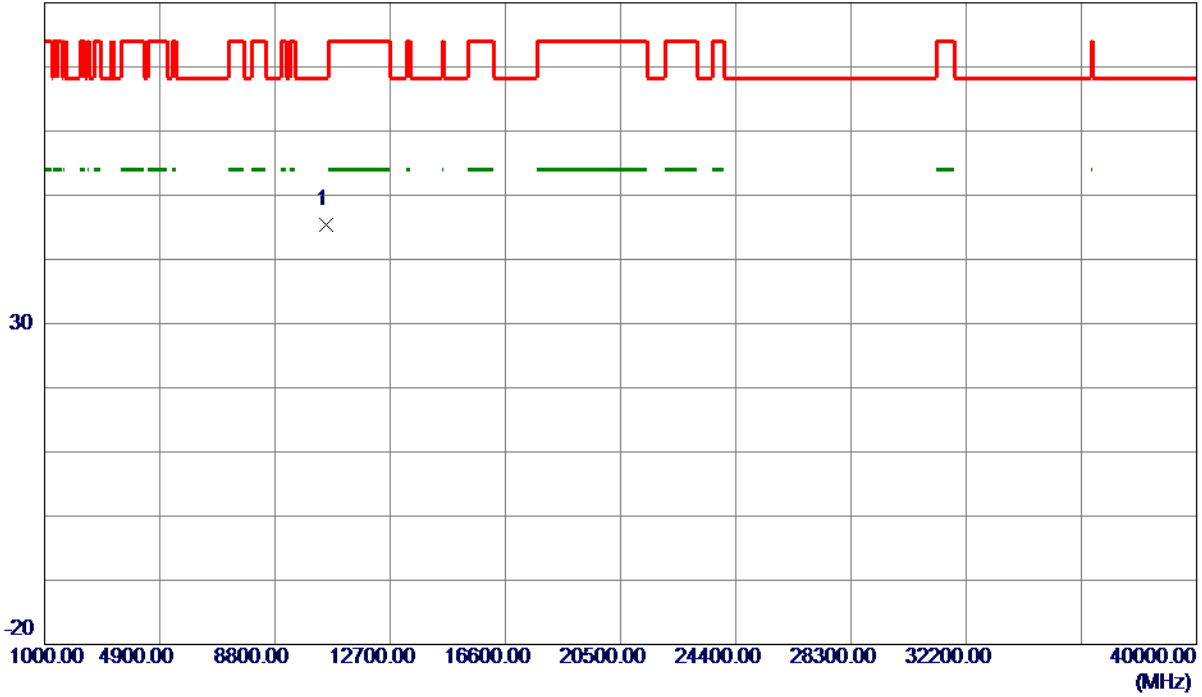

No.	Freq. MHz	Reading Level dBuV/m	Correct Factor dB	Measure ment dBuV/m	Limit dBuV/m	Margin dB	Detector	Comment
1 *	10518.8700	48.58	-3.25	45.33	68.30	-22.97	Peak	

REMARKS:

- (1) Measurement Value = Reading Level + Correct Factor.
- (2) Margin Level = Measurement Value - Limit Value.

Orthogonal Axis	X
Test Mode	UNII-2A_TX A Mode 5260 MHz

Horizontal

130 dBuV/m

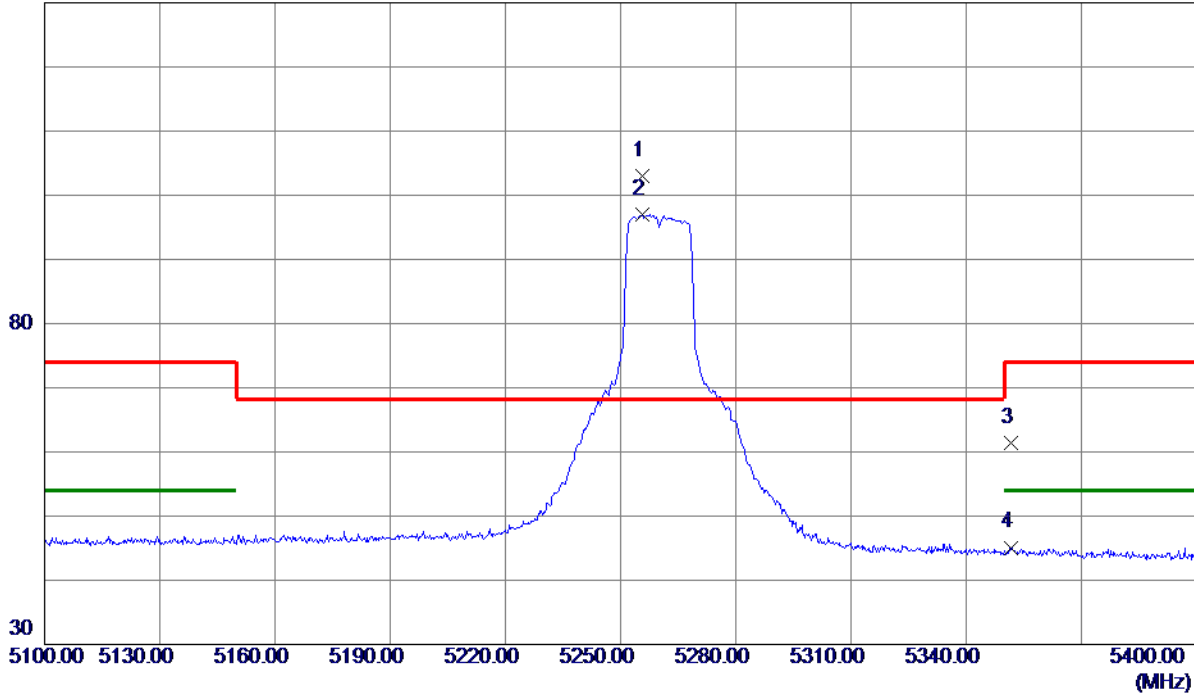

No.	Freq. MHz	Reading Level dBuV/m	Correct Factor dB	Measure ment dBuV/m	Limit dBuV/m	Margin dB	Detector	Comment
1 *	5255.7000	65.45	37.60	103.05	68.30	34.75	Peak	
2	5255.7000	59.34	37.60	96.94	999.00	-902.06	AVG	
3	5351.7000	23.67	37.74	61.41	74.00	-12.59	Peak	
4	5351.7000	7.36	37.74	45.10	54.00	-8.90	AVG	

REMARKS:

- (1) Measurement Value = Reading Level + Correct Factor.
- (2) Margin Level = Measurement Value - Limit Value.

Orthogonal Axis	X
Test Mode	UNII-2A_TX A Mode 5260 MHz

Horizontal

80 dBuV/m

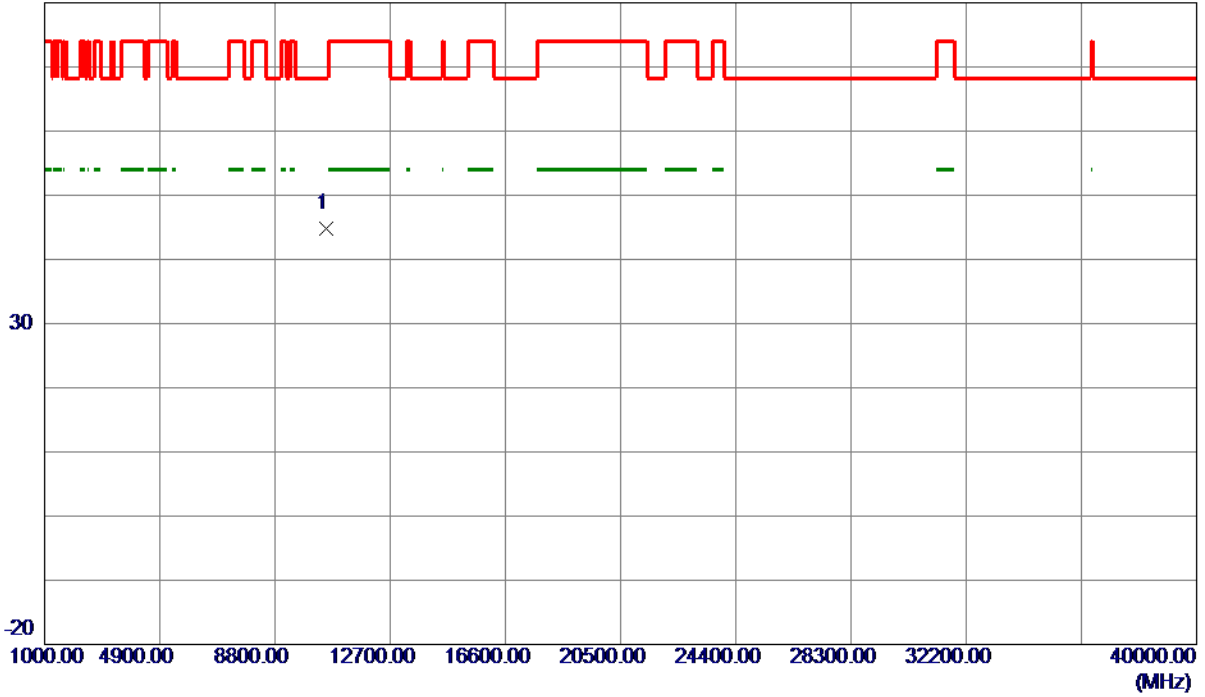

No.	Freq. MHz	Reading Level dBuV/m	Correct Factor dB	Measure ment dBuV/m	Limit dBuV/m	Margin dB	Detector	Comment
1 *	10520.3000	48.06	-3.25	44.81	68.30	-23.49	Peak	

REMARKS:

- (1) Measurement Value = Reading Level + Correct Factor.
- (2) Margin Level = Measurement Value - Limit Value.

Orthogonal Axis	X
Test Mode	UNII-2A_TX A Mode 5300 MHz

Vertical

130 dBuV/m

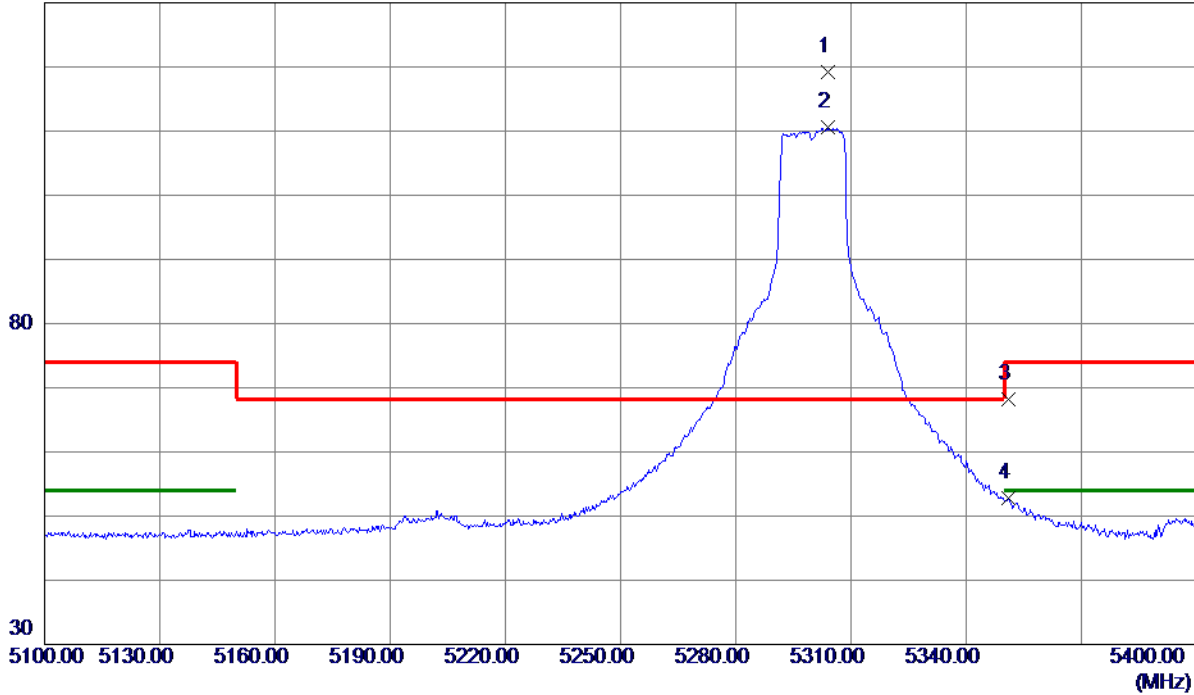

No.	Freq. MHz	Reading Level dBuV/m	Correct Factor dB	Measure ment dBuV/m	Limit dBuV/m	Margin dB	Detector	Comment
1 *	5304.1500	81.62	37.55	119.17	68.30	50.87	Peak	
2	5304.1500	73.00	37.55	110.55	999.00	-888.45	AVG	
3	5351.1000	30.42	37.74	68.16	74.00	-5.84	Peak	
4	5351.1000	15.06	37.74	52.80	54.00	-1.20	AVG	

REMARKS:

- (1) Measurement Value = Reading Level + Correct Factor.
- (2) Margin Level = Measurement Value - Limit Value.

Orthogonal Axis	X
Test Mode	UNII-2A_TX A Mode 5300 MHz

Vertical

80 dBuV/m

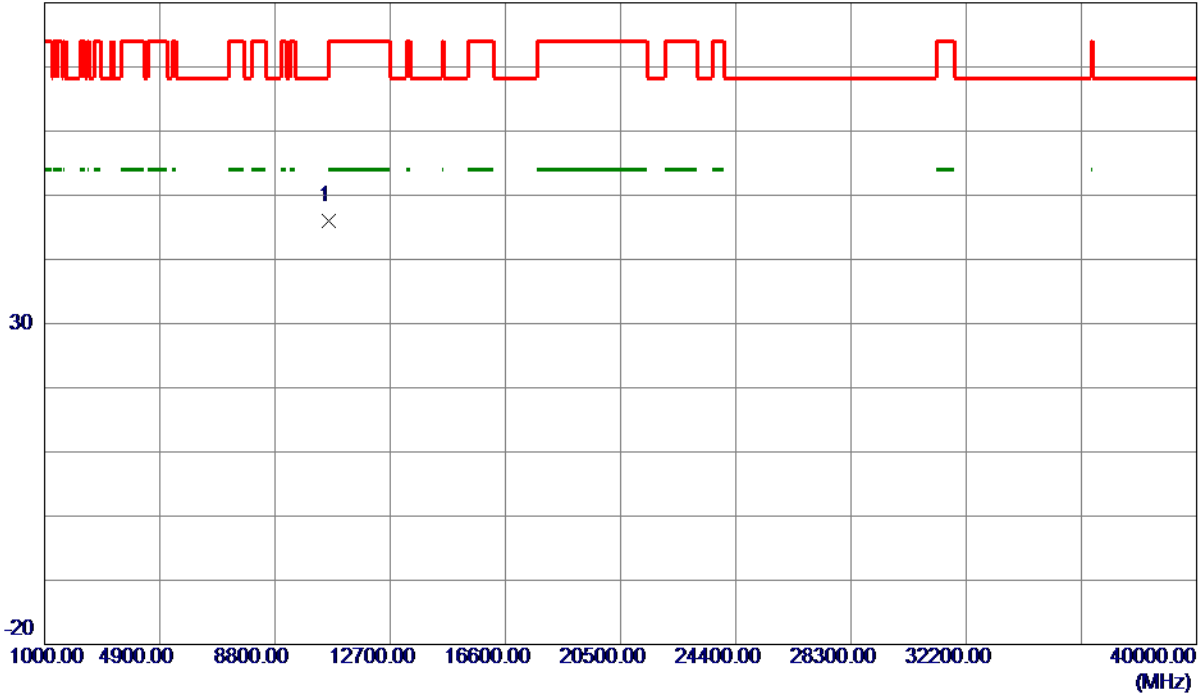

No.	Freq. MHz	Reading Level dBuV/m	Correct Factor dB	Measure ment dBuV/m	Limit dBuV/m	Margin dB	Detector	Comment
1 *	10600.9790	49.14	-3.12	46.02	74.00	-27.98	Peak	

REMARKS:

- (1) Measurement Value = Reading Level + Correct Factor.
- (2) Margin Level = Measurement Value - Limit Value.

Orthogonal Axis	X
Test Mode	UNII-2A_TX A Mode 5300 MHz

Horizontal

130 dBuV/m

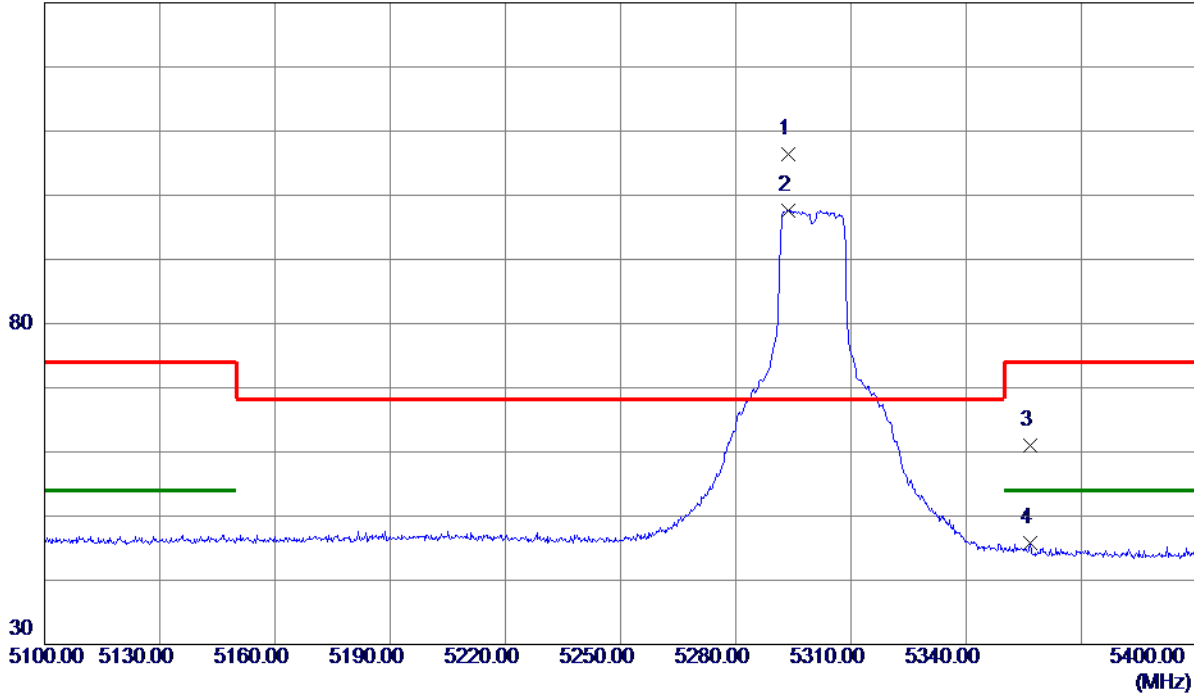

No.	Freq. MHz	Reading Level dBuV/m	Correct Factor dB	Measure ment dBuV/m	Limit dBuV/m	Margin dB	Detector	Comment
1 *	5293.6500	68.86	37.54	106.40	68.30	38.10	Peak	
2	5293.6500	60.08	37.54	97.62	999.00	-901.38	AVG	
3	5356.6500	23.25	37.76	61.01	74.00	-12.99	Peak	
4	5356.6500	8.00	37.76	45.76	54.00	-8.24	AVG	

REMARKS:

- (1) Measurement Value = Reading Level + Correct Factor.
- (2) Margin Level = Measurement Value - Limit Value.

Orthogonal Axis	X
Test Mode	UNII-2A_TX A Mode 5300 MHz

Horizontal

80 dBuV/m

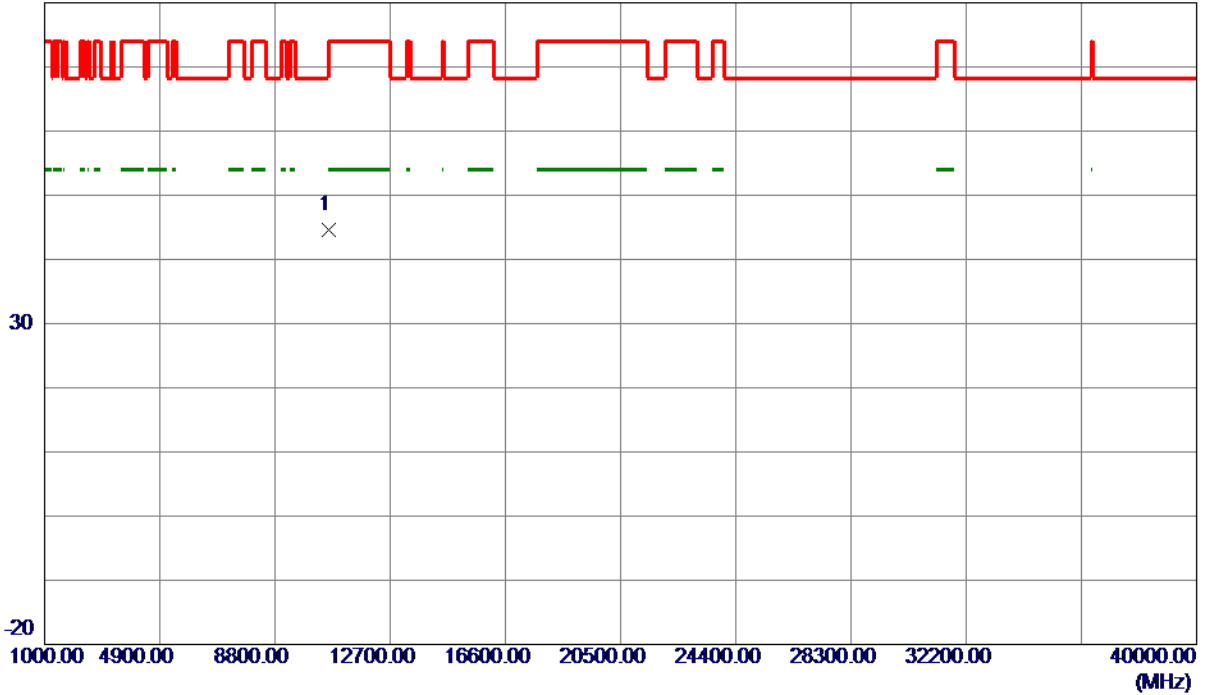

No.	Freq. MHz	Reading Level dBuV/m	Correct Factor dB	Measure ment dBuV/m	Limit dBuV/m	Margin dB	Detector	Comment
1 *	10599.9710	47.67	-3.12	44.55	68.30	-23.75	Peak	

REMARKS:

- (1) Measurement Value = Reading Level + Correct Factor.
- (2) Margin Level = Measurement Value - Limit Value.

Orthogonal Axis	X
Test Mode	UNII-2A_TX A Mode 5320 MHz

Vertical

130 dBuV/m

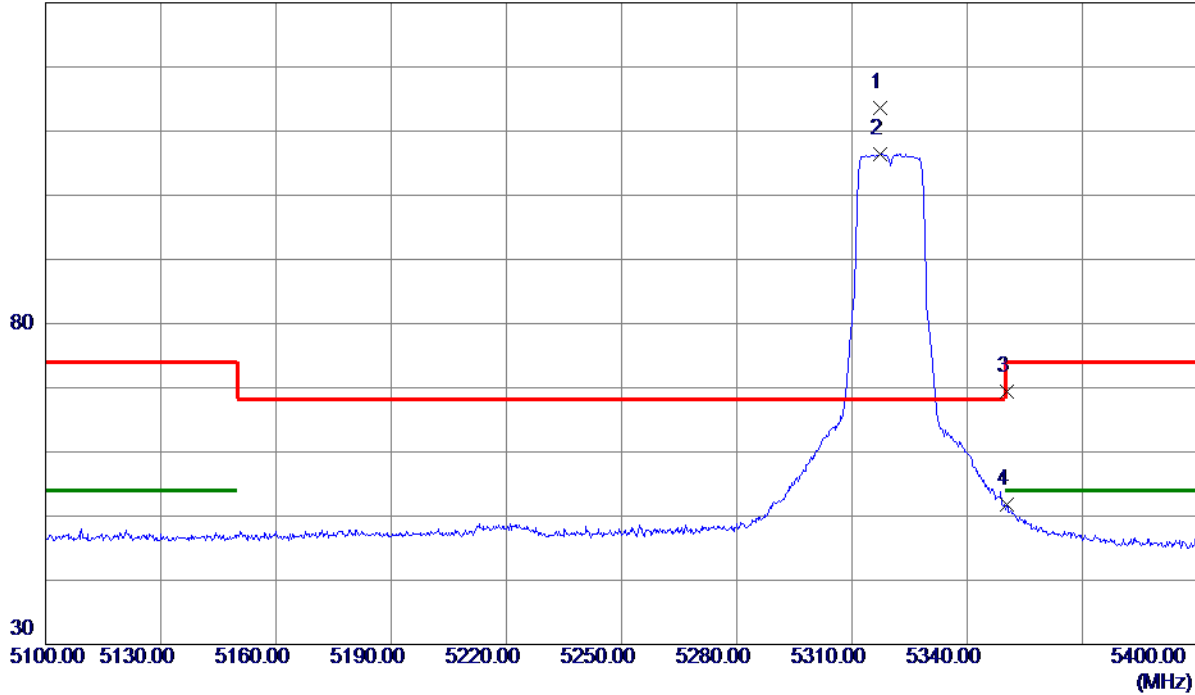

No.	Freq. MHz	Reading Level dBuV/m	Correct Factor dB	Measure ment dBuV/m	Limit dBuV/m	Margin dB	Detector	Comment
1 *	5317.2000	75.94	37.60	113.54	68.30	45.24	Peak	
2	5317.2000	68.79	37.60	106.39	999.00	-892.61	AVG	
3	5350.3500	31.68	37.74	69.42	74.00	-4.58	Peak	
4	5350.3500	14.15	37.74	51.89	54.00	-2.11	AVG	

REMARKS:

- (1) Measurement Value = Reading Level + Correct Factor.
- (2) Margin Level = Measurement Value - Limit Value.

Orthogonal Axis	X
Test Mode	UNII-2A_TX A Mode 5320 MHz

Vertical

80 dBuV/m

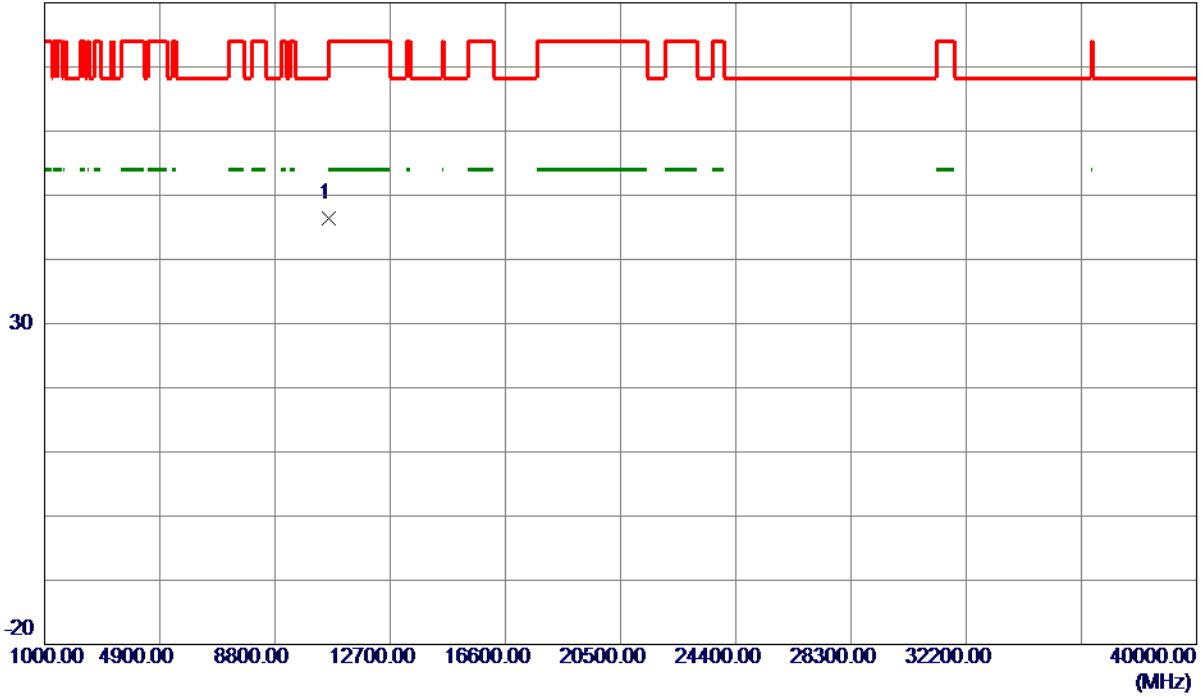

No.	Freq. MHz	Reading Level dBuV/m	Correct Factor dB	Measure ment dBuV/m	Limit dBuV/m	Margin dB	Detector	Comment
1 *	10641.1230	49.46	-3.08	46.38	74.00	-27.62	Peak	

REMARKS:

- (1) Measurement Value = Reading Level + Correct Factor.
- (2) Margin Level = Measurement Value - Limit Value.

Orthogonal Axis	X
Test Mode	UNII-2A_TX A Mode 5320 MHz

Horizontal

130 dBuV/m

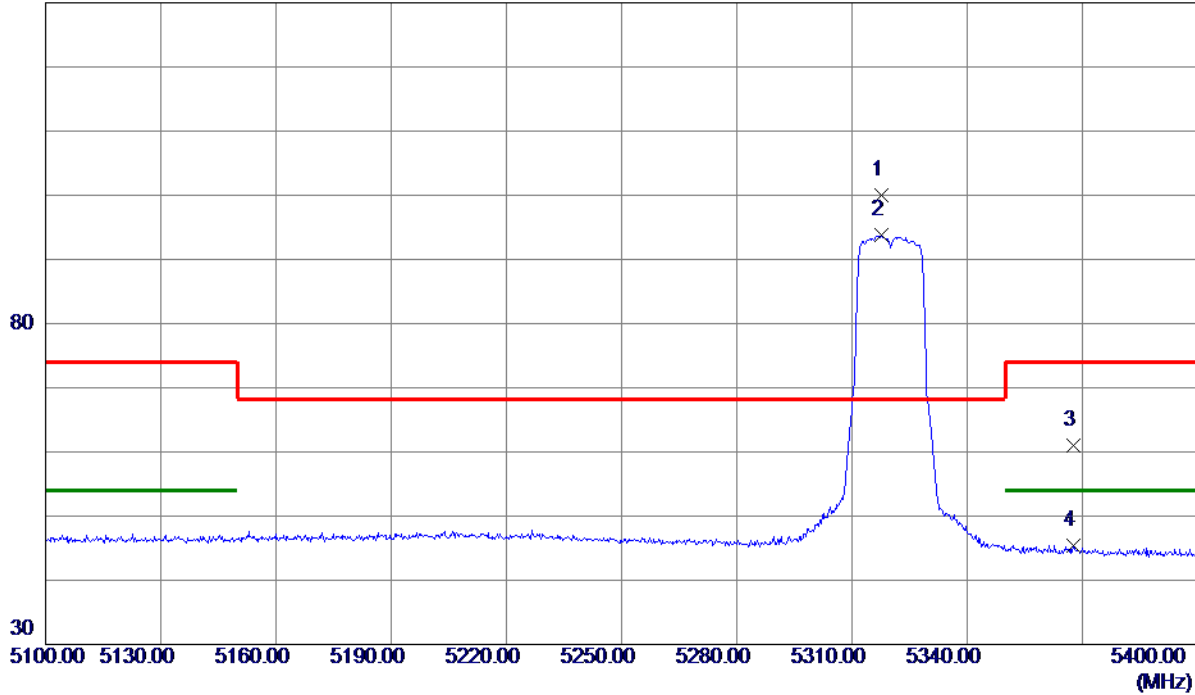

No.	Freq. MHz	Reading Level dBuV/m	Correct Factor dB	Measure ment dBuV/m	Limit dBuV/m	Margin dB	Detector	Comment
1 *	5317.8000	62.43	37.61	100.04	68.30	31.74	Peak	
2	5317.8000	56.13	37.61	93.74	999.00	-905.26	AVG	
3	5367.6000	23.12	37.81	60.93	74.00	-13.07	Peak	
4	5367.6000	7.68	37.81	45.49	54.00	-8.51	AVG	

REMARKS:

- (1) Measurement Value = Reading Level + Correct Factor.
- (2) Margin Level = Measurement Value - Limit Value.

Orthogonal Axis	X
Test Mode	UNII-2A_TX A Mode 5320 MHz

Horizontal

80 dBuV/m

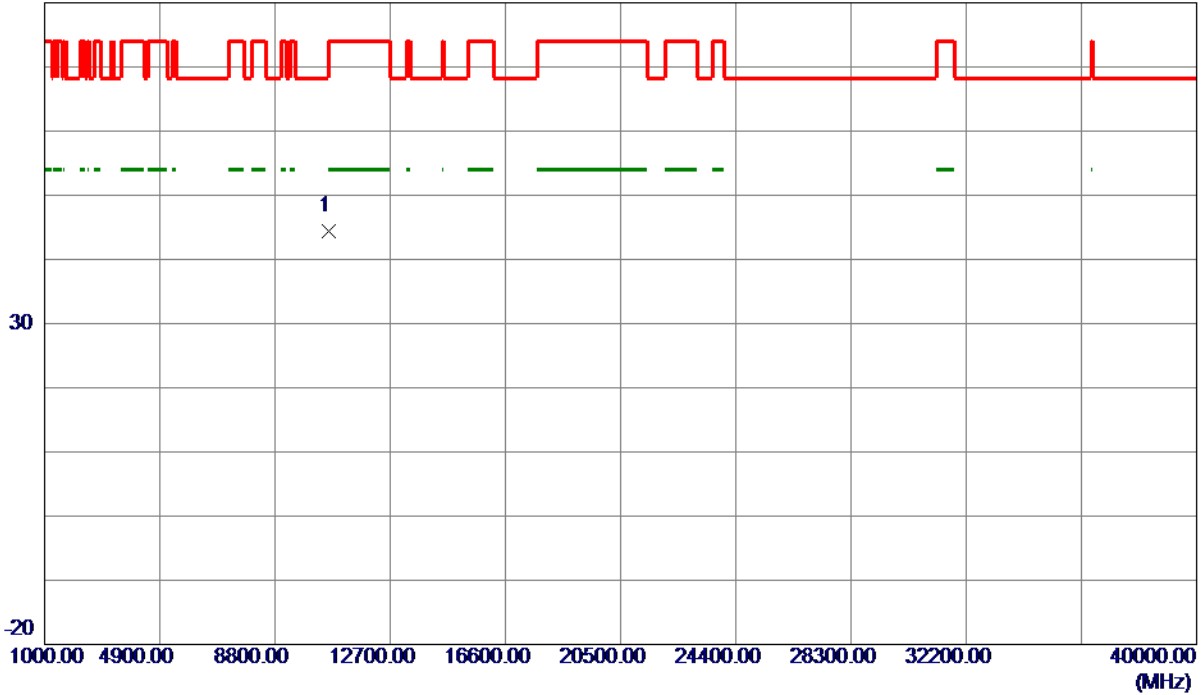

No.	Freq. MHz	Reading Level dBuV/m	Correct Factor dB	Measure ment dBuV/m	Limit dBuV/m	Margin dB	Detector	Comment
1 *	10641.4240	47.48	-3.08	44.40	74.00	-29.60	Peak	

REMARKS:

- (1) Measurement Value = Reading Level + Correct Factor.
- (2) Margin Level = Measurement Value - Limit Value.

Orthogonal Axis	X
Test Mode	UNII-2C_TX A Mode 5500 MHz

Vertical

130 dBuV/m

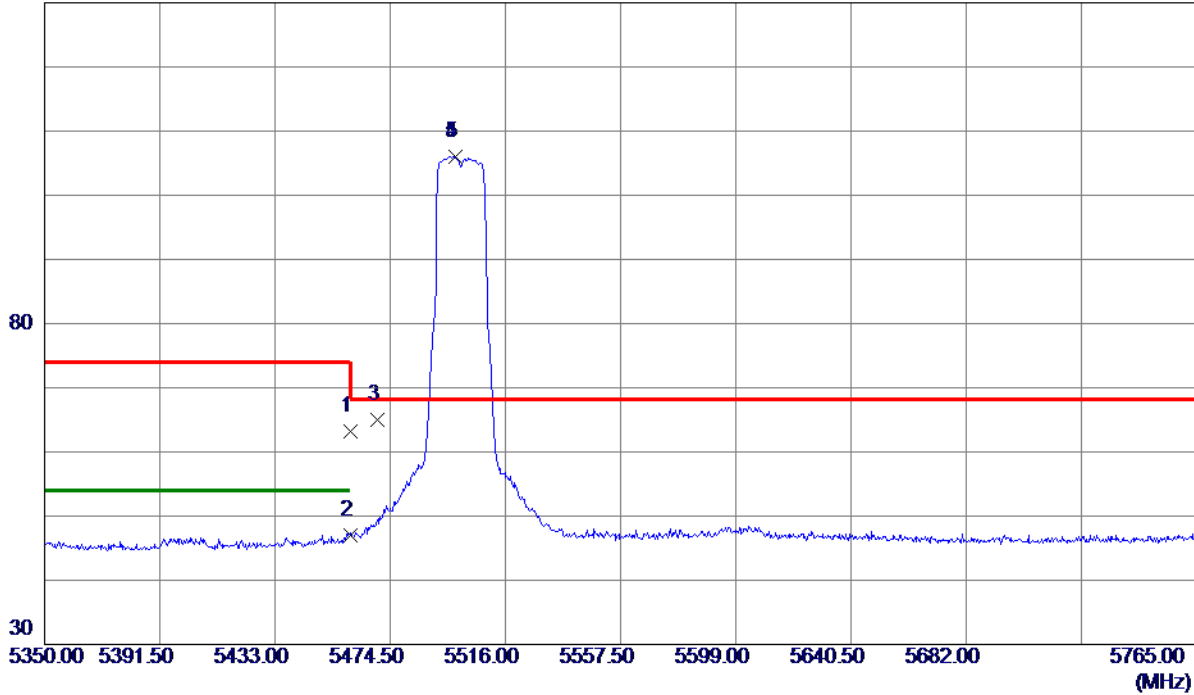

No.	Freq. MHz	Reading Level dBuV/m	Correct Factor dB	Measure ment dBuV/m	Limit dBuV/m	Margin dB	Detector	Comment
1	5460.0000	25.15	38.12	63.27	74.00	-10.73	Peak	
2	5460.0000	8.86	38.12	46.98	54.00	-7.02	AVG	
3	5470.0000	26.79	38.15	64.94	68.30	-3.36	Peak	
4 *	5497.9480	67.77	38.23	106.00	68.30	37.70	Peak	
5	5497.9480	67.77	38.23	106.00	999.00	-893.00	AVG	

REMARKS:

- (1) Measurement Value = Reading Level + Correct Factor.
- (2) Margin Level = Measurement Value - Limit Value.

Orthogonal Axis	X
Test Mode	UNII-2C_TX A Mode 5500 MHz

Vertical

80 dBuV/m

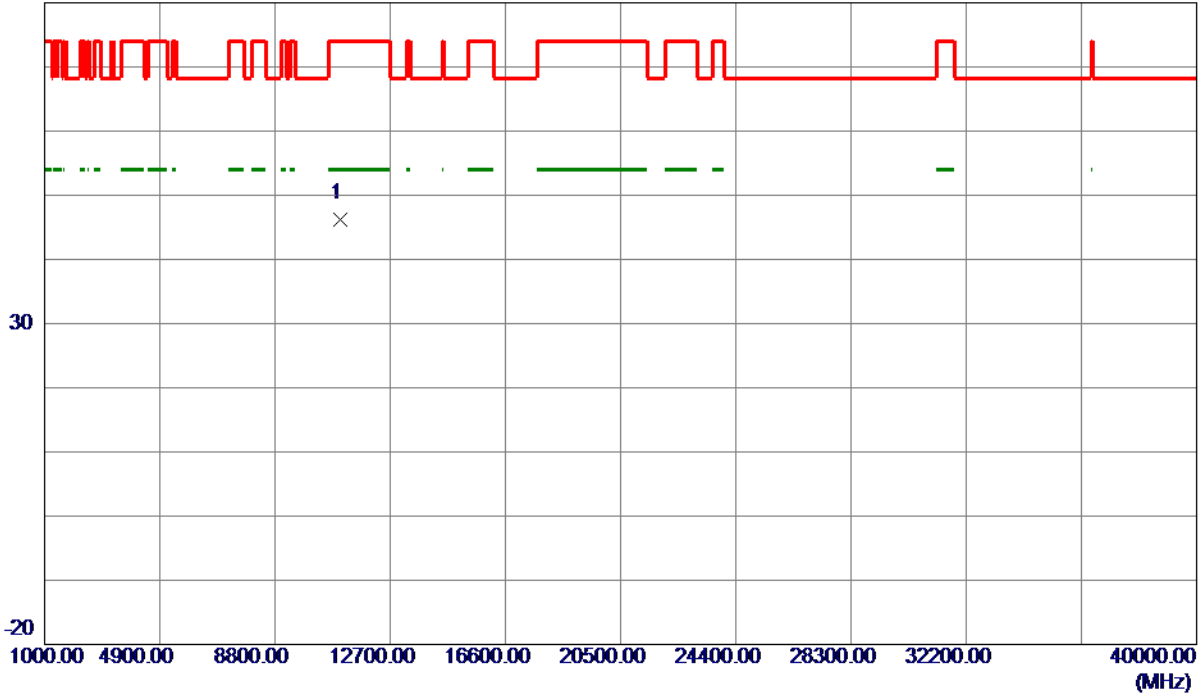

No.	Freq. MHz	Reading Level dBuV/m	Correct Factor dB	Measure ment dBuV/m	Limit dBuV/m	Margin dB	Detector	Comment
1 *	10998.6810	48.76	-2.46	46.30	74.00	-27.70	Peak	

REMARKS:

- (1) Measurement Value = Reading Level + Correct Factor.
- (2) Margin Level = Measurement Value - Limit Value.

Orthogonal Axis	X
Test Mode	UNII-2C_TX A Mode 5500 MHz

Horizontal

130 dBuV/m

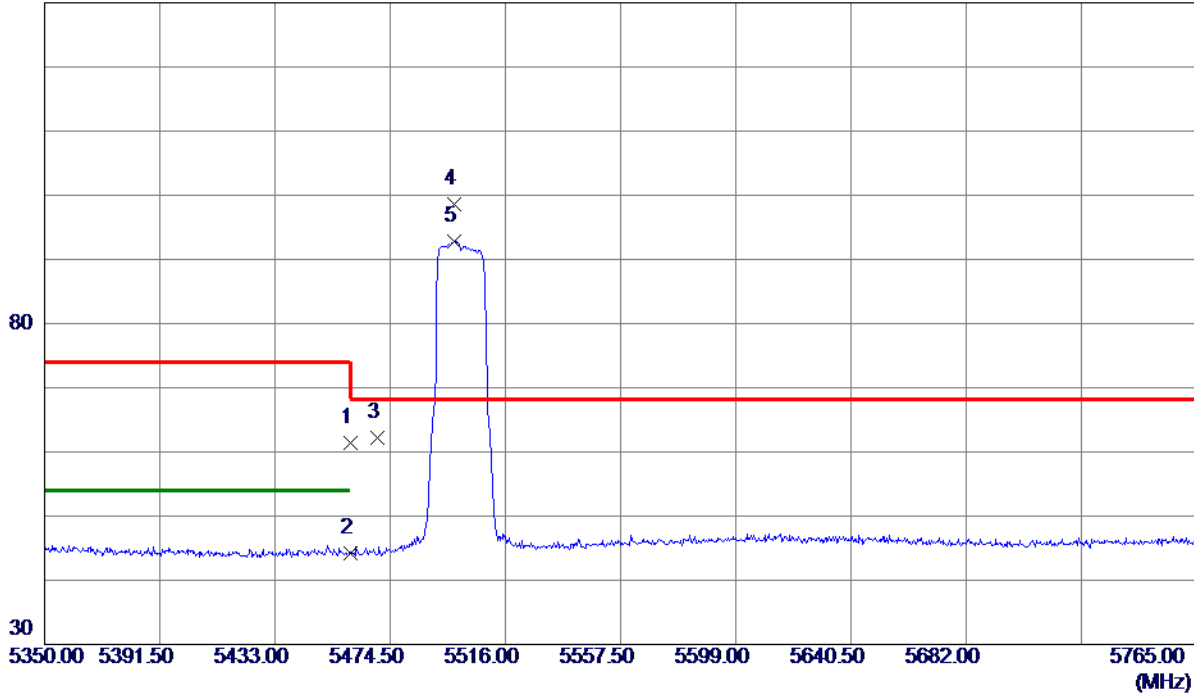

No.	Freq. MHz	Reading Level dBuV/m	Correct Factor dB	Measure ment dBuV/m	Limit dBuV/m	Margin dB	Detector	Comment
1	5460.0000	23.23	38.12	61.35	74.00	-12.65	Peak	
2	5460.0000	6.16	38.12	44.28	54.00	-9.72	AVG	
3	5470.0000	24.12	38.15	62.27	68.30	-6.03	Peak	
4 *	5497.7400	60.46	38.23	98.69	68.30	30.39	Peak	
5	5497.7400	54.59	38.23	92.82	999.00	-906.18	AVG	

REMARKS:

- (1) Measurement Value = Reading Level + Correct Factor.
- (2) Margin Level = Measurement Value - Limit Value.

Orthogonal Axis	X
Test Mode	UNII-2C_TX A Mode 5500 MHz

Horizontal

80 dBuV/m

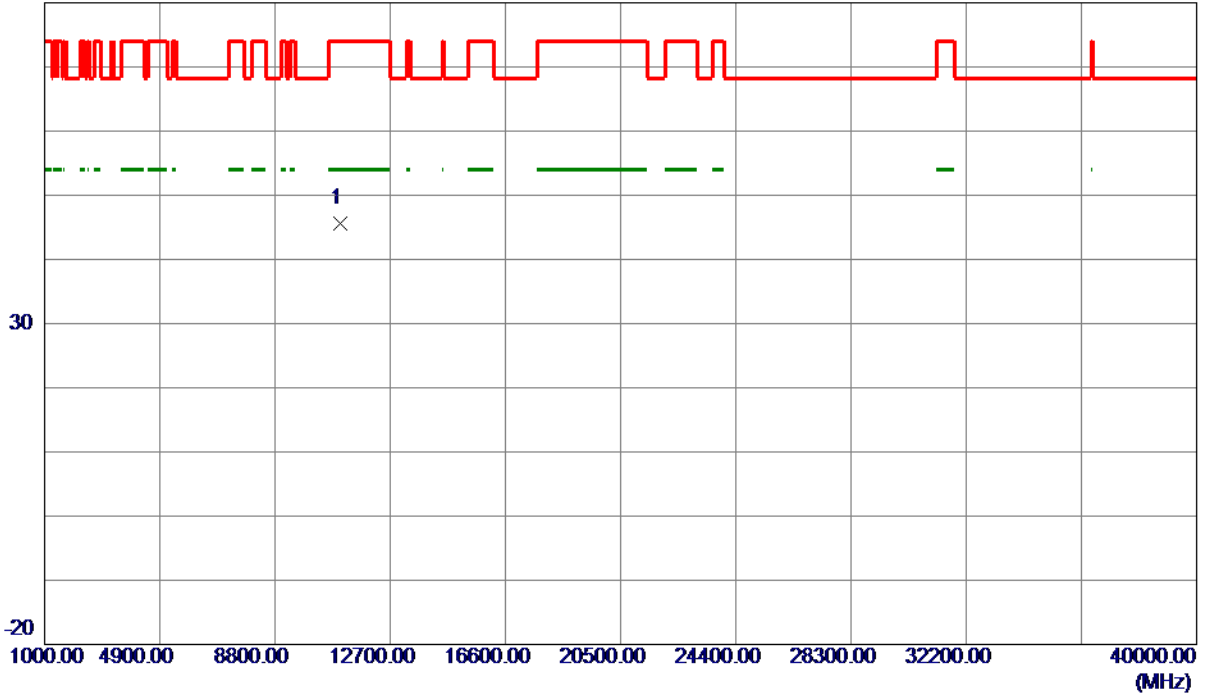

No.	Freq. MHz	Reading Level dBuV/m	Correct Factor dB	Measure ment dBuV/m	Limit dBuV/m	Margin dB	Detector	Comment
1 *	11000.7870	48.06	-2.46	45.60	74.00	-28.40	Peak	

REMARKS:

- (1) Measurement Value = Reading Level + Correct Factor.
- (2) Margin Level = Measurement Value - Limit Value.

Orthogonal Axis	X
Test Mode	UNII-2C_TX A Mode 5580 MHz

Vertical

130 dBuV/m

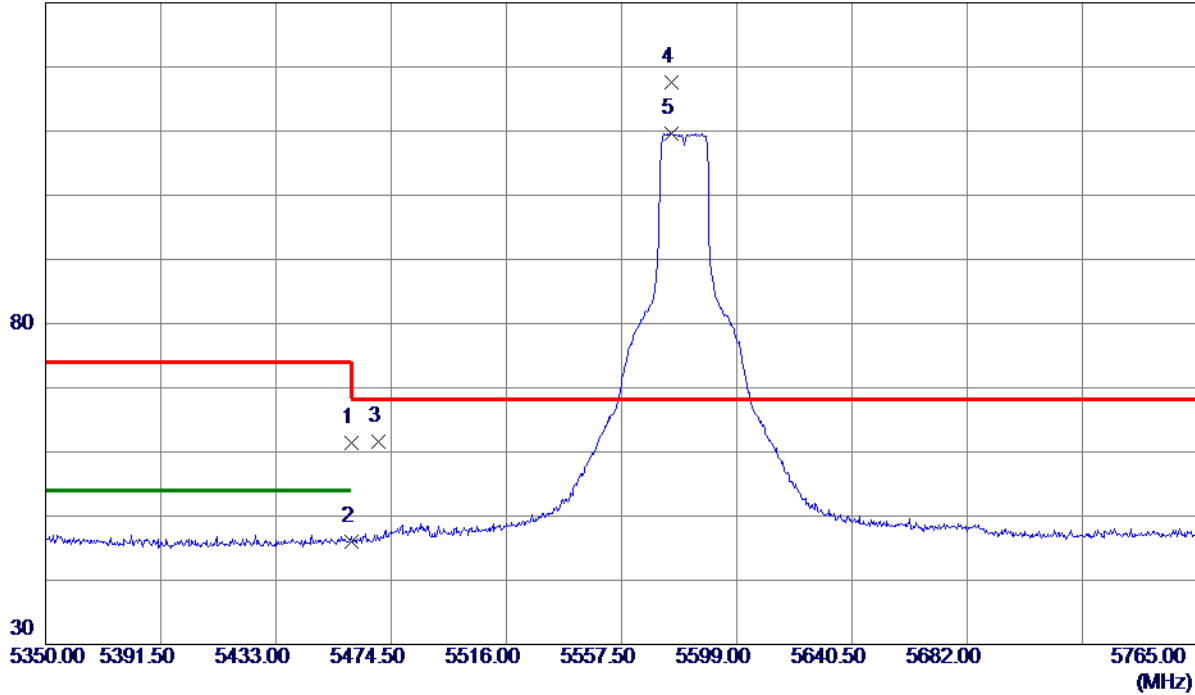

No.	Freq. MHz	Reading Level dBuV/m	Correct Factor dB	Measure ment dBuV/m	Limit dBuV/m	Margin dB	Detector	Comment
1	5460.0000	23.22	38.12	61.34	74.00	-12.66	Peak	
2	5460.0000	7.81	38.12	45.93	54.00	-8.07	AVG	
3	5470.0000	23.53	38.15	61.68	68.30	-6.62	Peak	
4 *	5575.3450	79.19	38.32	117.51	68.30	49.21	Peak	
5	5575.3450	71.30	38.32	109.62	999.00	-889.38	AVG	

REMARKS:

- (1) Measurement Value = Reading Level + Correct Factor.
- (2) Margin Level = Measurement Value - Limit Value.

Orthogonal Axis	X
Test Mode	UNII-2C_TX A Mode 5580 MHz

Vertical

80 dBuV/m

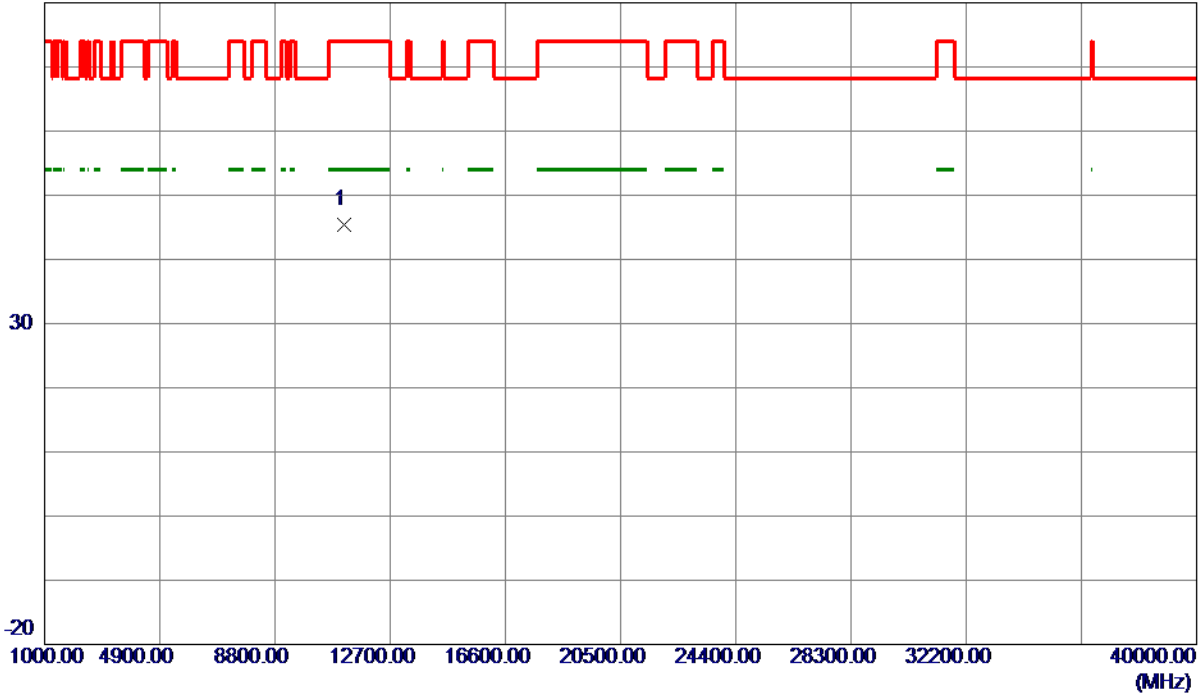

No.	Freq. MHz	Reading Level dBuV/m	Correct Factor dB	Measure ment dBuV/m	Limit dBuV/m	Margin dB	Detector	Comment
1 *	11160.0000	48.18	-2.72	45.46	74.00	-28.54	Peak	

REMARKS:

- (1) Measurement Value = Reading Level + Correct Factor.
- (2) Margin Level = Measurement Value - Limit Value.

Orthogonal Axis	X
Test Mode	UNII-2C_TX A Mode 5580 MHz

Horizontal

130 dBuV/m

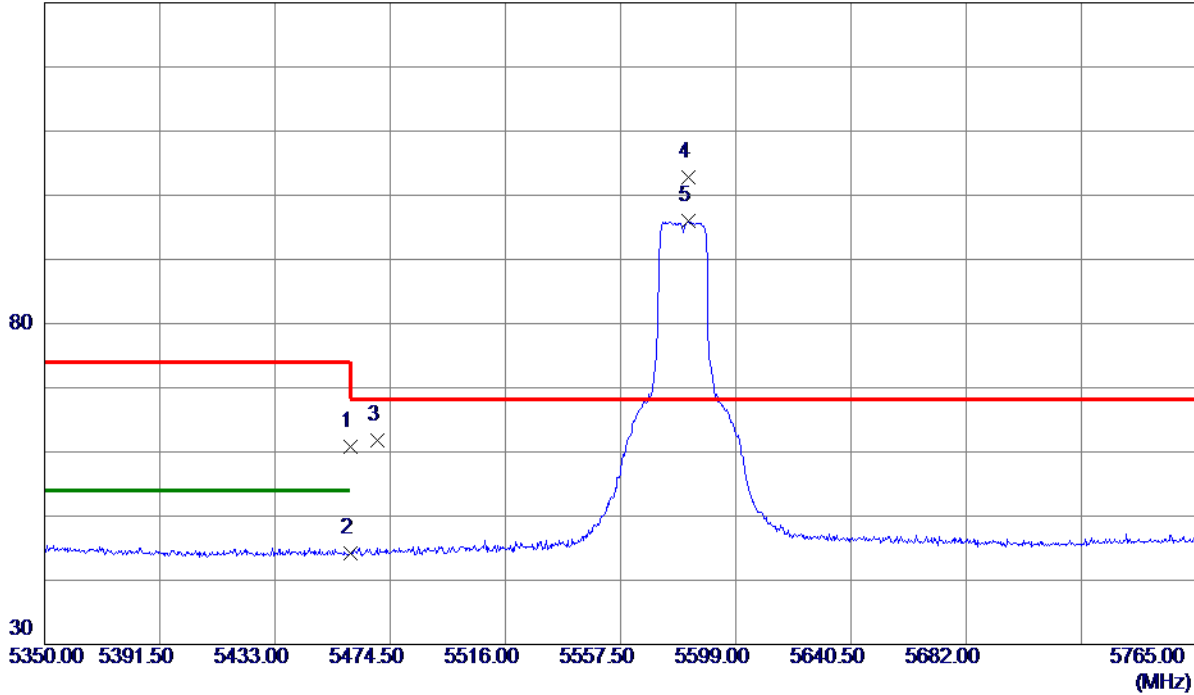

No.	Freq. MHz	Reading Level dBuV/m	Correct Factor dB	Measure ment dBuV/m	Limit dBuV/m	Margin dB	Detector	Comment
1	5460.0000	22.76	38.12	60.88	74.00	-13.12	Peak	
2	5460.0000	6.14	38.12	44.26	54.00	-9.74	AVG	
3	5470.0000	23.56	38.15	61.71	68.30	-6.59	Peak	
4 *	5581.7780	64.48	38.32	102.80	68.30	34.50	Peak	
5	5581.7780	57.61	38.32	95.93	999.00	-903.07	AVG	

REMARKS:

- (1) Measurement Value = Reading Level + Correct Factor.
- (2) Margin Level = Measurement Value - Limit Value.

Orthogonal Axis	X
Test Mode	UNII-2C_TX A Mode 5580 MHz

Horizontal

80 dBuV/m

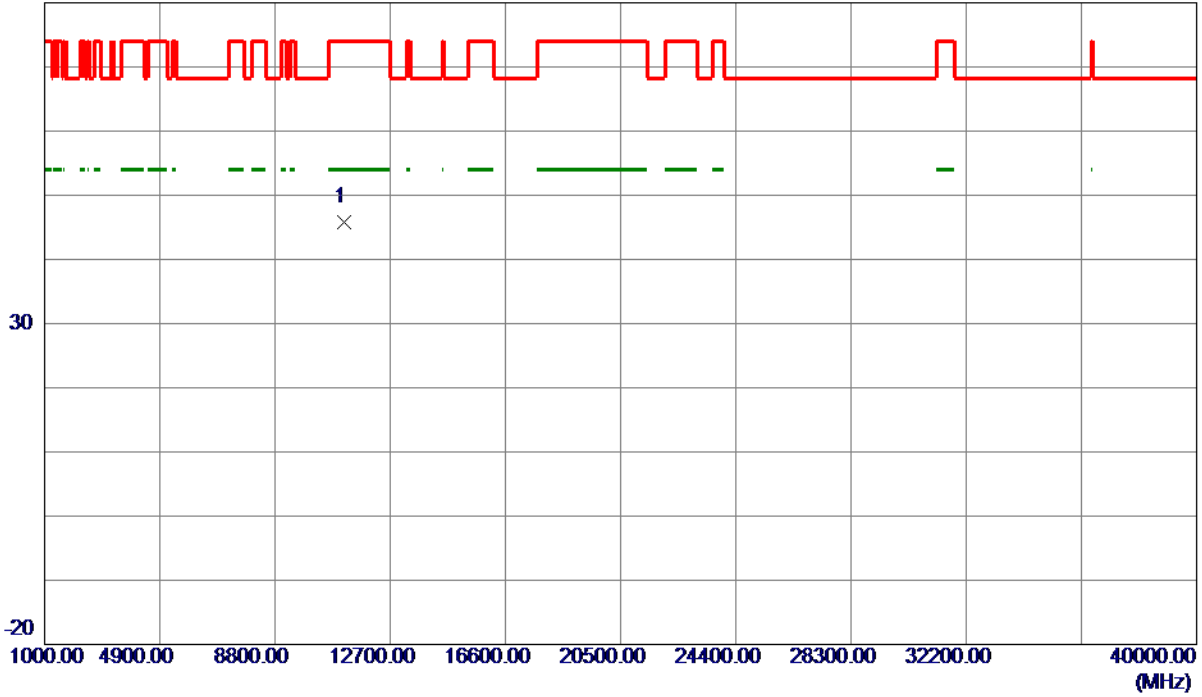

No.	Freq. MHz	Reading Level dBuV/m	Correct Factor dB	Measure ment dBuV/m	Limit dBuV/m	Margin dB	Detector	Comment
1 *	11160.0000	48.59	-2.72	45.87	74.00	-28.13	Peak	

REMARKS:

- (1) Measurement Value = Reading Level + Correct Factor.
- (2) Margin Level = Measurement Value - Limit Value.

Orthogonal Axis	X
Test Mode	UNII-2C_TX A Mode 5700 MHz

Vertical

130 dBuV/m

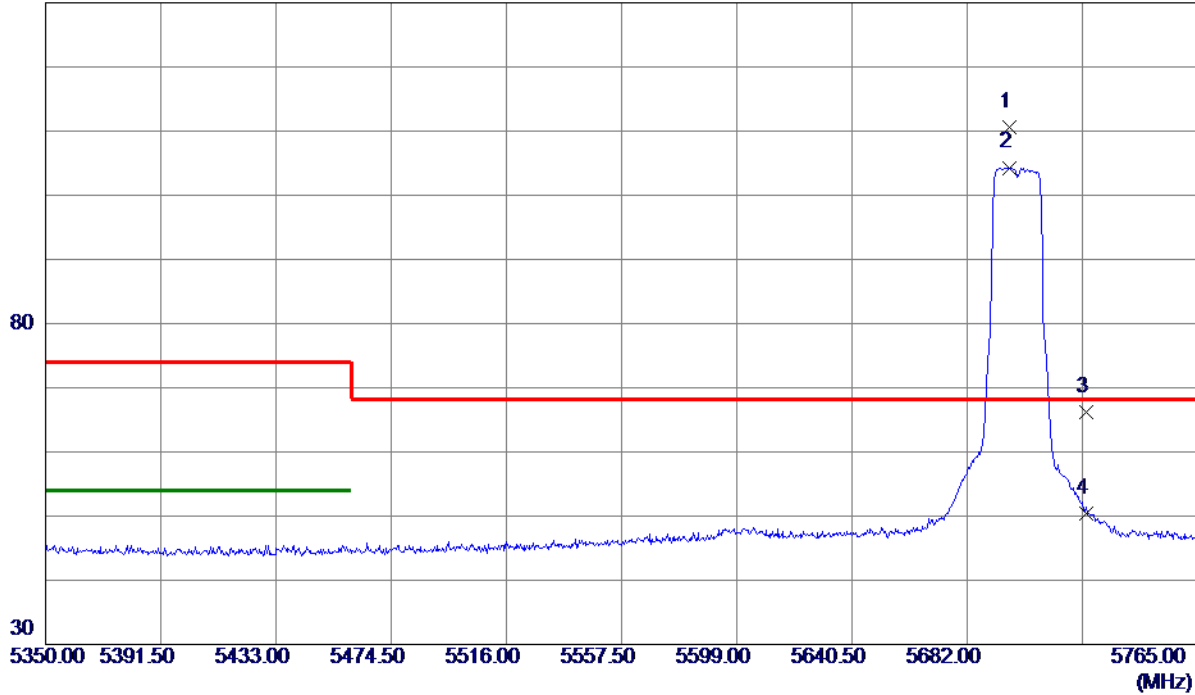

No.	Freq. MHz	Reading Level dBuV/m	Correct Factor dB	Measure ment dBuV/m	Limit dBuV/m	Margin dB	Detector	Comment
1 *	5697.3550	72.12	38.40	110.52	68.30	42.22	Peak	
2	5697.3550	65.90	38.40	104.30	999.00	-894.70	AVG	
3	5725.0000	27.75	38.50	66.25	68.30	-2.05	Peak	
4	5725.0000	11.94	38.50	50.44	999.00	-948.56	AVG	

REMARKS:

- (1) Measurement Value = Reading Level + Correct Factor.
- (2) Margin Level = Measurement Value - Limit Value.

Orthogonal Axis	X
Test Mode	UNII-2C_TX A Mode 5700 MHz

Vertical

80 dBuV/m

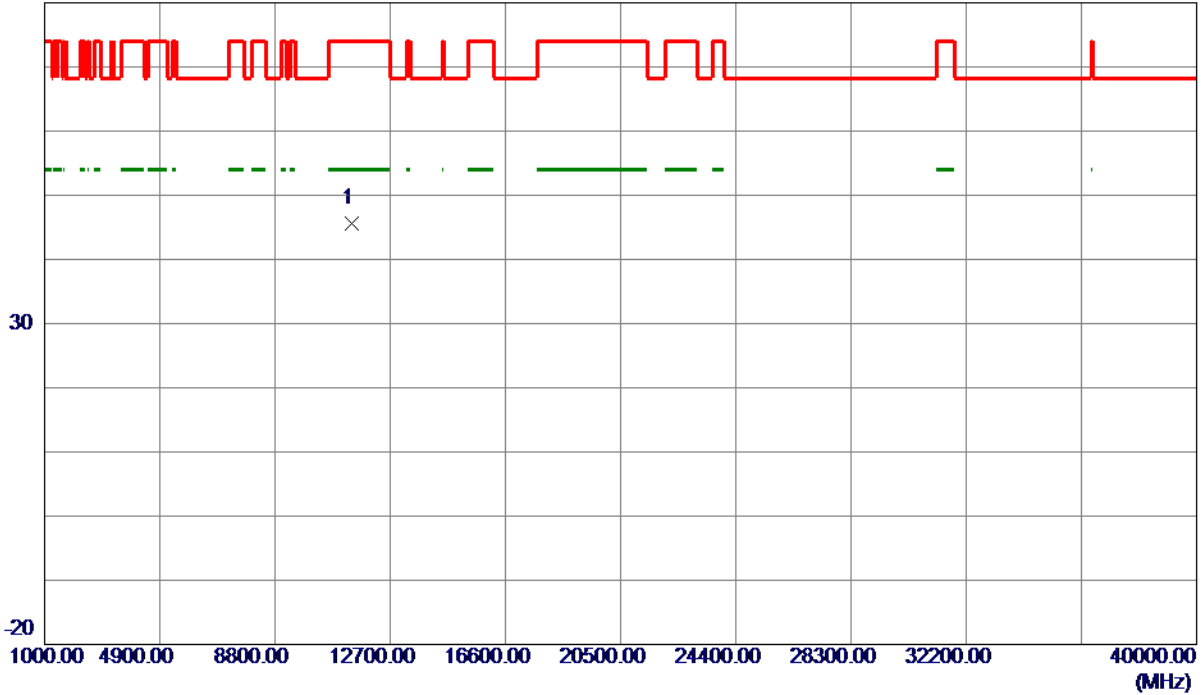

No.	Freq. MHz	Reading Level dBuV/m	Correct Factor dB	Measure ment dBuV/m	Limit dBuV/m	Margin dB	Detector	Comment
1 *	11402.1110	48.07	-2.55	45.52	74.00	-28.48	Peak	

REMARKS:

- (1) Measurement Value = Reading Level + Correct Factor.
- (2) Margin Level = Measurement Value - Limit Value.

Orthogonal Axis	X
Test Mode	UNII-2C_TX A Mode 5700 MHz

Horizontal

130 dBuV/m

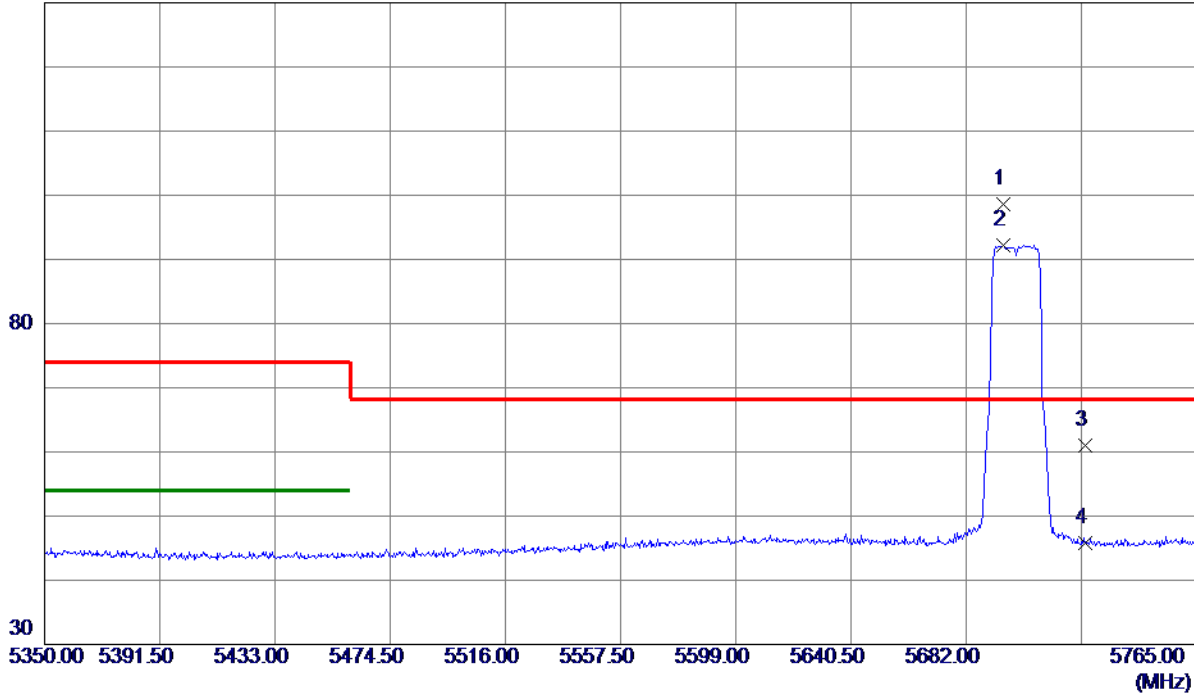

No.	Freq. MHz	Reading Level dBuV/m	Correct Factor dB	Measure ment dBuV/m	Limit dBuV/m	Margin dB	Detector	Comment
1 *	5695.2799	60.12	38.40	98.52	68.30	30.22	Peak	
2	5695.2799	53.82	38.40	92.22	999.00	-906.78	AVG	
3	5725.0000	22.43	38.50	60.93	68.30	-7.37	Peak	
4	5725.0000	7.36	38.50	45.86	999.00	-953.14	AVG	

REMARKS:

- (1) Measurement Value = Reading Level + Correct Factor.
- (2) Margin Level = Measurement Value - Limit Value.

Orthogonal Axis	X
Test Mode	UNII-2C_TX A Mode 5700 MHz

Horizontal

80 dBuV/m

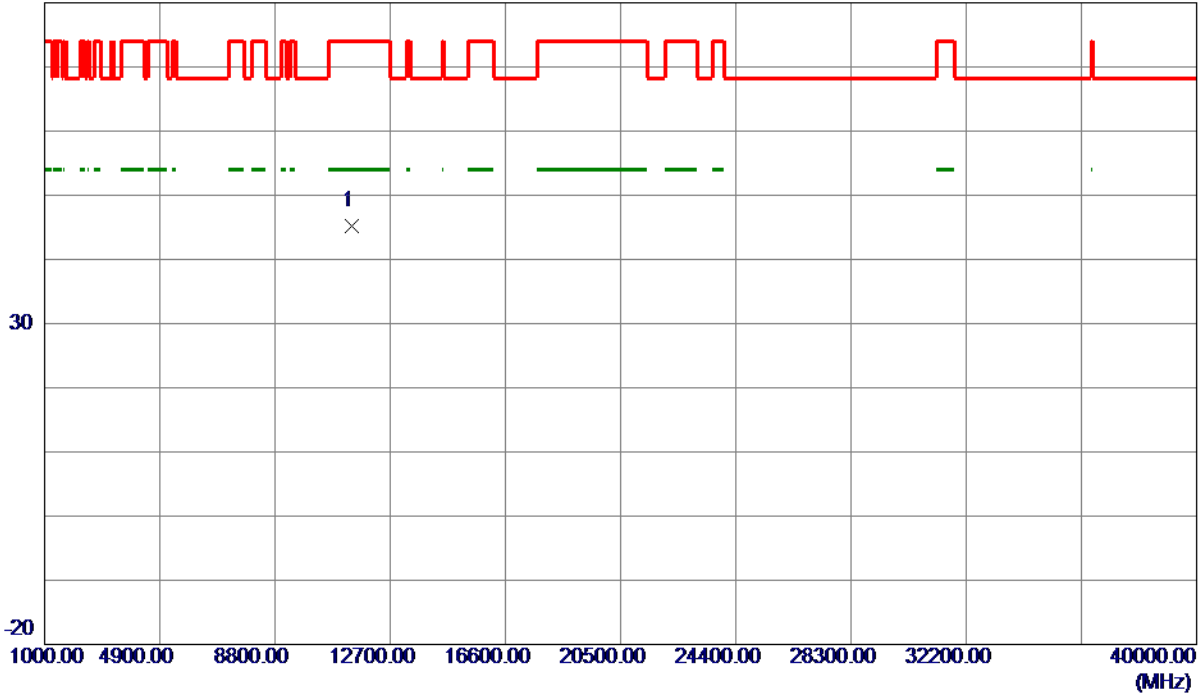

No.	Freq. MHz	Reading Level dBuV/m	Correct Factor dB	Measure ment dBuV/m	Limit dBuV/m	Margin dB	Detector	Comment
1 *	11401.9450	47.80	-2.55	45.25	74.00	-28.75	Peak	

REMARKS:

- (1) Measurement Value = Reading Level + Correct Factor.
- (2) Margin Level = Measurement Value - Limit Value.

Orthogonal Axis	X
Test Mode	UNII-2A_TX AC (VHT20) Mode 5260 MHz

Vertical

130 dBuV/m

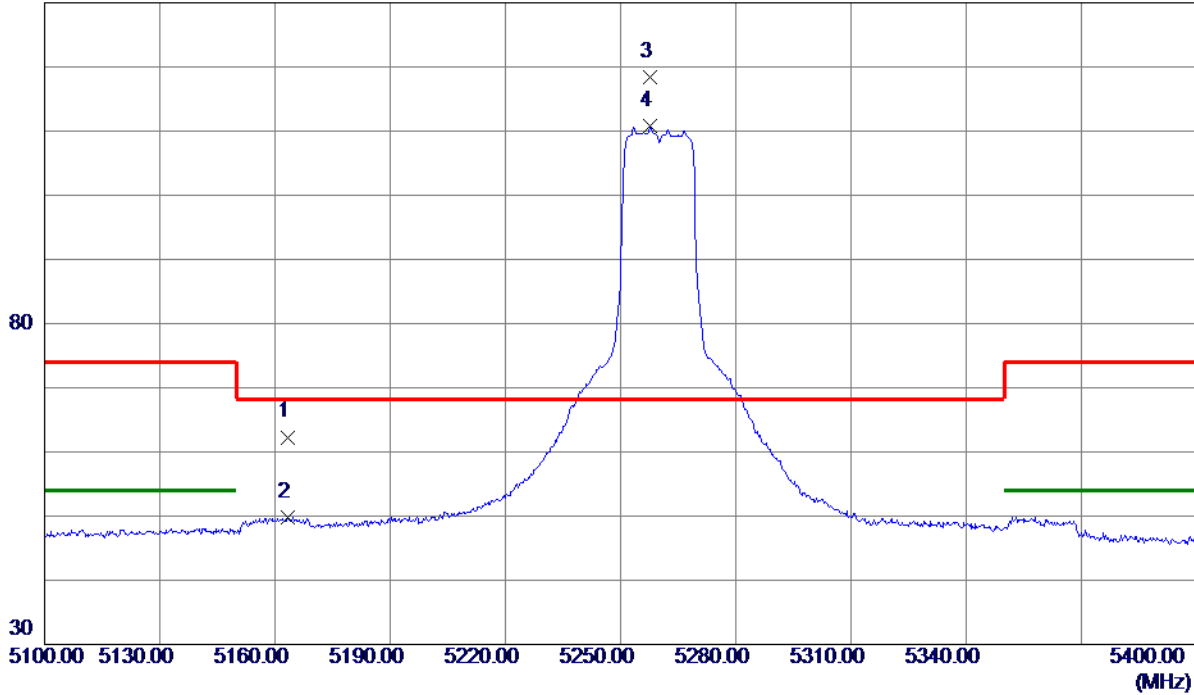

No.	Freq. MHz	Reading Level dBuV/m	Correct Factor dB	Measure ment dBuV/m	Limit dBuV/m	Margin dB	Detector	Comment
1	5163.4500	24.48	37.82	62.30	68.30	-6.00	Peak	
2	5163.4500	11.92	37.82	49.74	999.00	-949.26	AVG	
3 *	5257.8000	80.75	37.60	118.35	68.30	50.05	Peak	
4	5257.8000	73.22	37.60	110.82	999.00	-888.18	AVG	

REMARKS:

- (1) Measurement Value = Reading Level + Correct Factor.
- (2) Margin Level = Measurement Value - Limit Value.

Orthogonal Axis	X
Test Mode	UNII-2A_TX AC (VHT20) Mode 5260 MHz

Vertical

80 dBuV/m

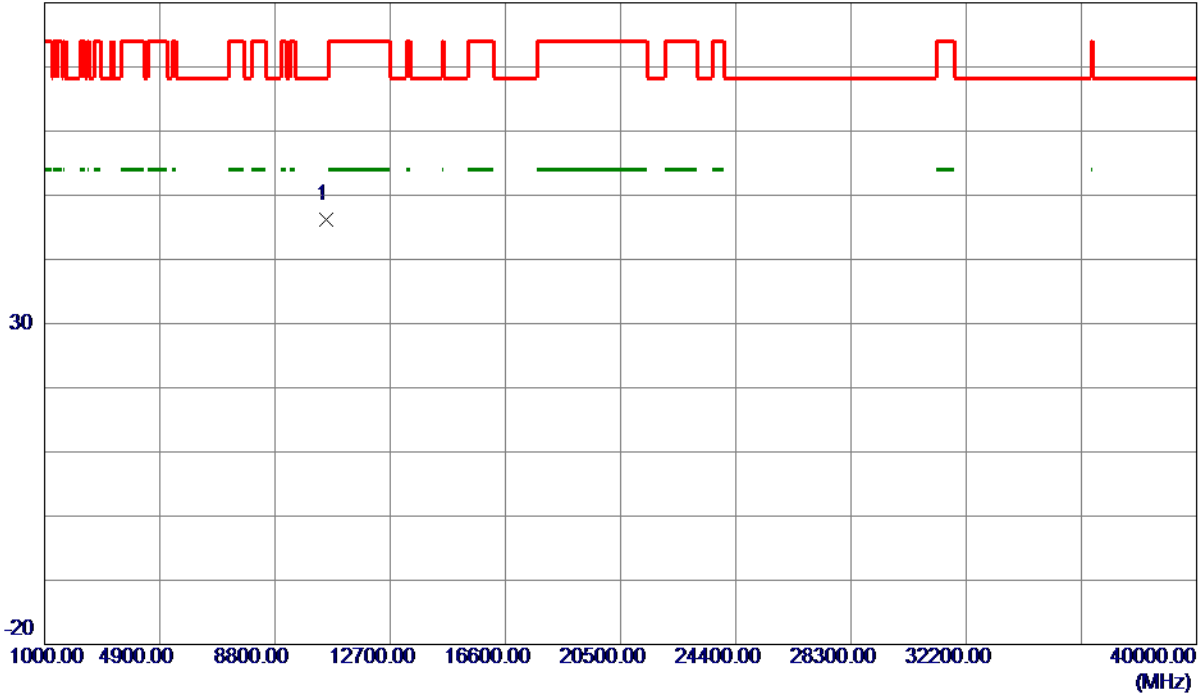

No.	Freq. MHz	Reading Level dBuV/m	Correct Factor dB	Measure ment dBuV/m	Limit dBuV/m	Margin dB	Detector	Comment
1 *	10518.6449	49.44	-3.25	46.19	68.30	-22.11	Peak	

REMARKS:

- (1) Measurement Value = Reading Level + Correct Factor.
- (2) Margin Level = Measurement Value - Limit Value.

Orthogonal Axis	X
Test Mode	UNII-2A_TX AC (VHT20) Mode 5260 MHz

Horizontal

130 dBuV/m

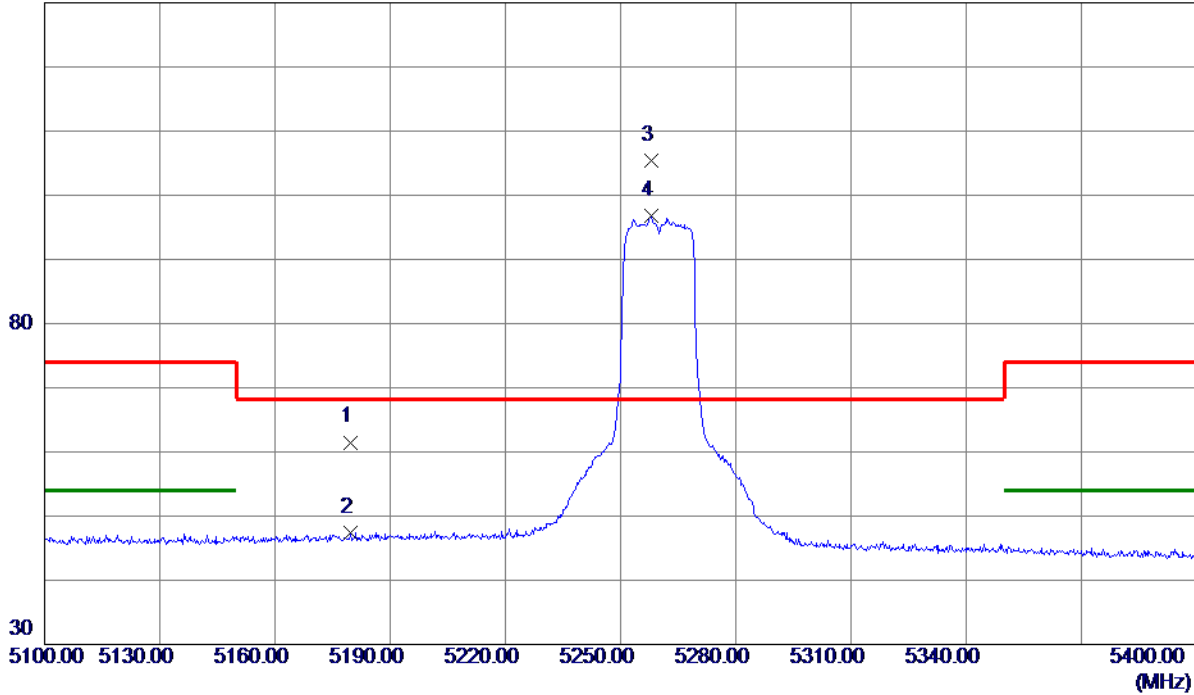

No.	Freq. MHz	Reading Level dBuV/m	Correct Factor dB	Measure ment dBuV/m	Limit dBuV/m	Margin dB	Detector	Comment
1	5179.8000	23.74	37.76	61.50	68.30	-6.80	Peak	
2	5179.8000	9.56	37.76	47.32	999.00	-951.68	AVG	
3 *	5258.1000	67.71	37.60	105.31	68.30	37.01	Peak	
4	5258.1000	59.22	37.60	96.82	999.00	-902.18	AVG	

REMARKS:

- (1) Measurement Value = Reading Level + Correct Factor.
- (2) Margin Level = Measurement Value - Limit Value.

Orthogonal Axis	X
Test Mode	UNII-2A_TX AC (VHT20) Mode 5260 MHz

Horizontal

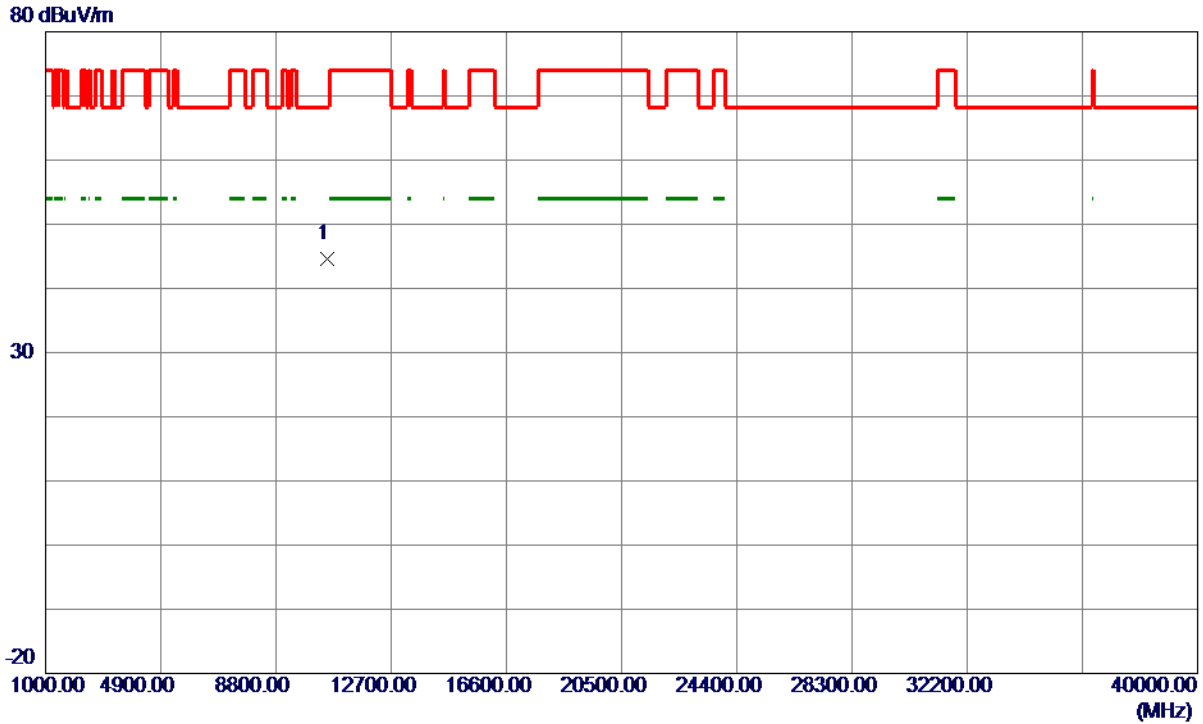

No.	Freq. MHz	Reading Level dBuV/m	Correct Factor dB	Measure ment dBuV/m	Limit dBuV/m	Margin dB	Detector	Comment
1 *	10519.0359	47.83	-3.25	44.58	68.30	-23.72	Peak	

REMARKS:

- (1) Measurement Value = Reading Level + Correct Factor.
- (2) Margin Level = Measurement Value - Limit Value.

Orthogonal Axis	X
Test Mode	UNII-2A_TX AC (VHT20) Mode 5300 MHz

Vertical

130 dBuV/m

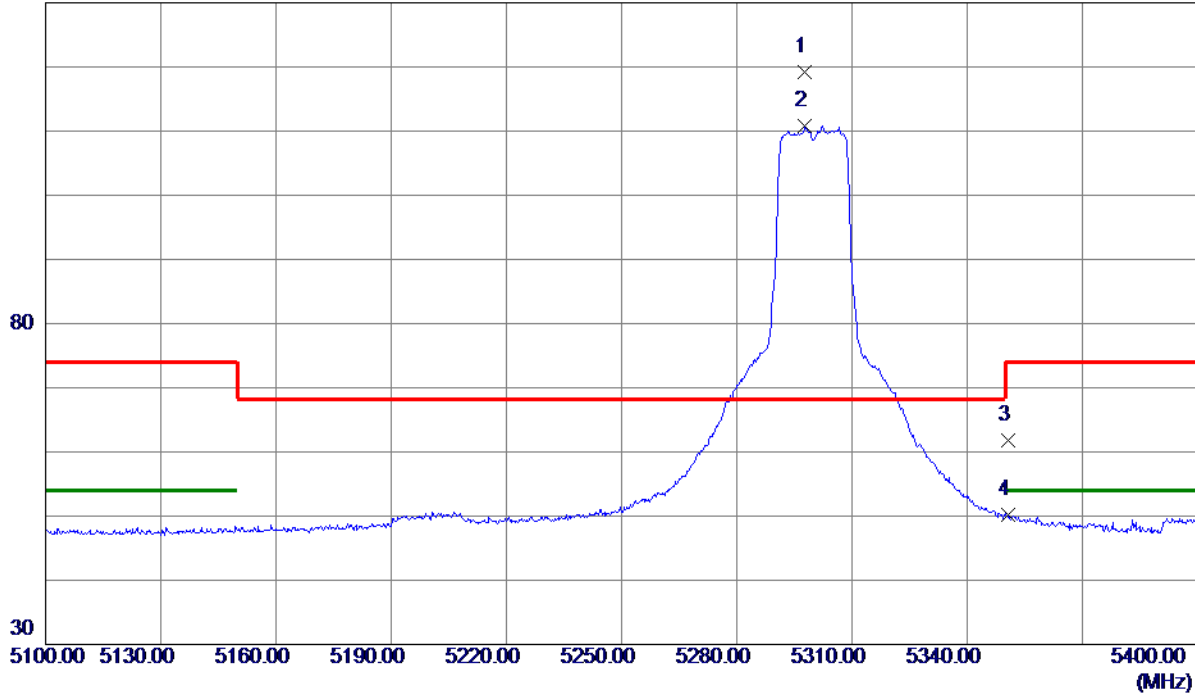

No.	Freq. MHz	Reading Level dBuV/m	Correct Factor dB	Measure ment dBuV/m	Limit dBuV/m	Margin dB	Detector	Comment
1 *	5297.7000	81.71	37.54	119.25	68.30	50.95	Peak	
2	5297.7000	73.33	37.54	110.87	999.00	-888.13	AVG	
3	5350.6500	24.00	37.74	61.74	74.00	-12.26	Peak	
4	5350.6500	12.40	37.74	50.14	54.00	-3.86	AVG	

REMARKS:

- (1) Measurement Value = Reading Level + Correct Factor.
- (2) Margin Level = Measurement Value - Limit Value.

Orthogonal Axis	X
Test Mode	UNII-2A_TX AC (VHT20) Mode 5300 MHz

Vertical

80 dBuV/m

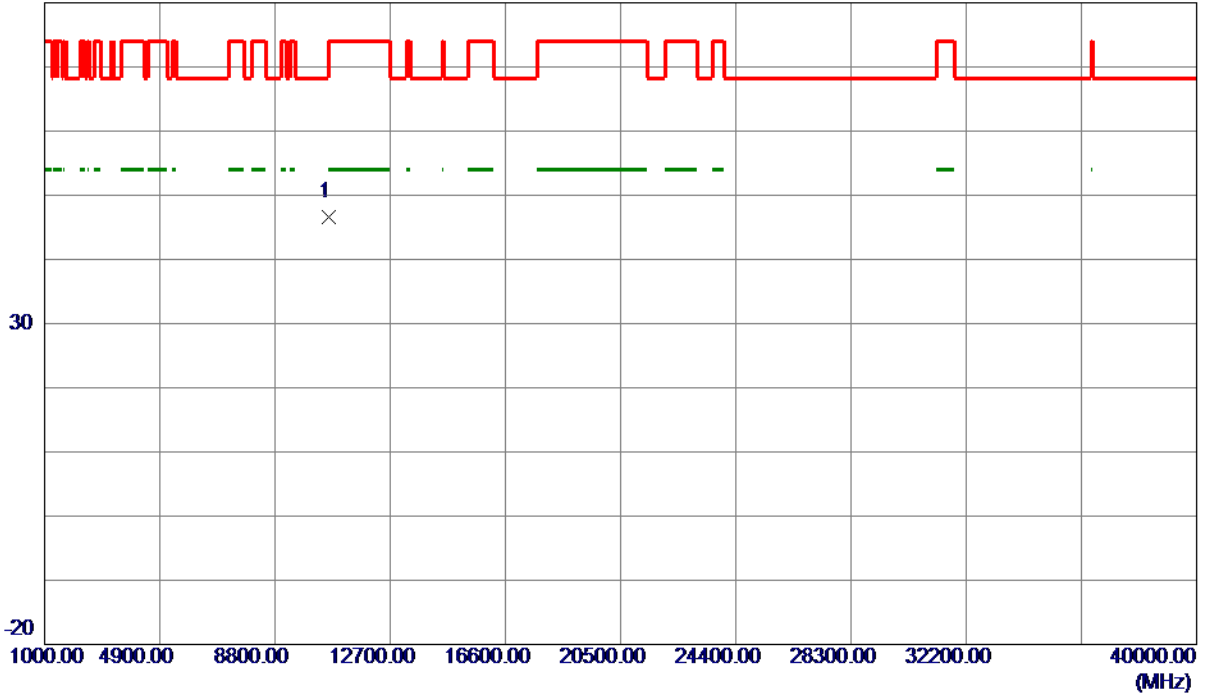

No.	Freq. MHz	Reading Level dBuV/m	Correct Factor dB	Measure ment dBuV/m	Limit dBuV/m	Margin dB	Detector	Comment
1 *	10601.4200	49.71	-3.12	46.59	74.00	-27.41	Peak	

REMARKS:

- (1) Measurement Value = Reading Level + Correct Factor.
- (2) Margin Level = Measurement Value - Limit Value.

Orthogonal Axis	X
Test Mode	UNII-2A_TX AC (VHT20) Mode 5300 MHz

Horizontal

130 dBuV/m

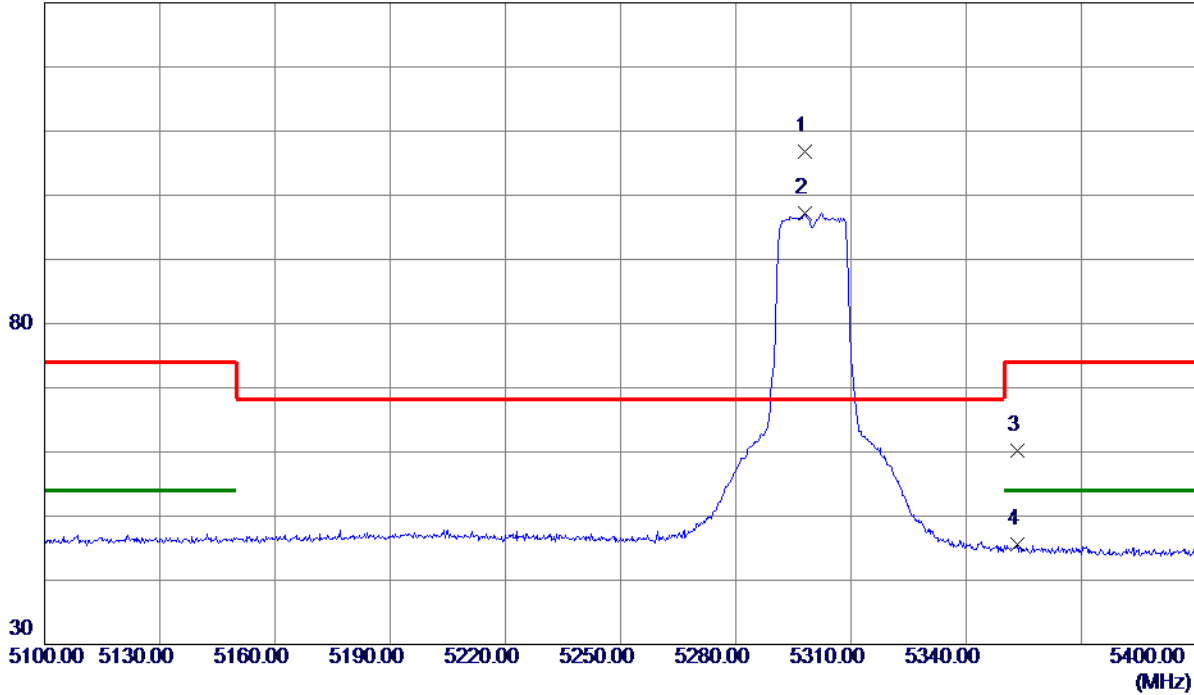

No.	Freq. MHz	Reading Level dBuV/m	Correct Factor dB	Measure ment dBuV/m	Limit dBuV/m	Margin dB	Detector	Comment
1 *	5297.8500	69.18	37.54	106.72	68.30	38.42	Peak	
2	5297.8500	59.75	37.54	97.29	999.00	-901.71	AVG	
3	5353.2000	22.52	37.75	60.27	74.00	-13.73	Peak	
4	5353.2000	7.94	37.75	45.69	54.00	-8.31	AVG	

REMARKS:

- (1) Measurement Value = Reading Level + Correct Factor.
- (2) Margin Level = Measurement Value - Limit Value.

Orthogonal Axis	X
Test Mode	UNII-2A_TX AC (VHT20) Mode 5300 MHz

Horizontal

80 dBuV/m

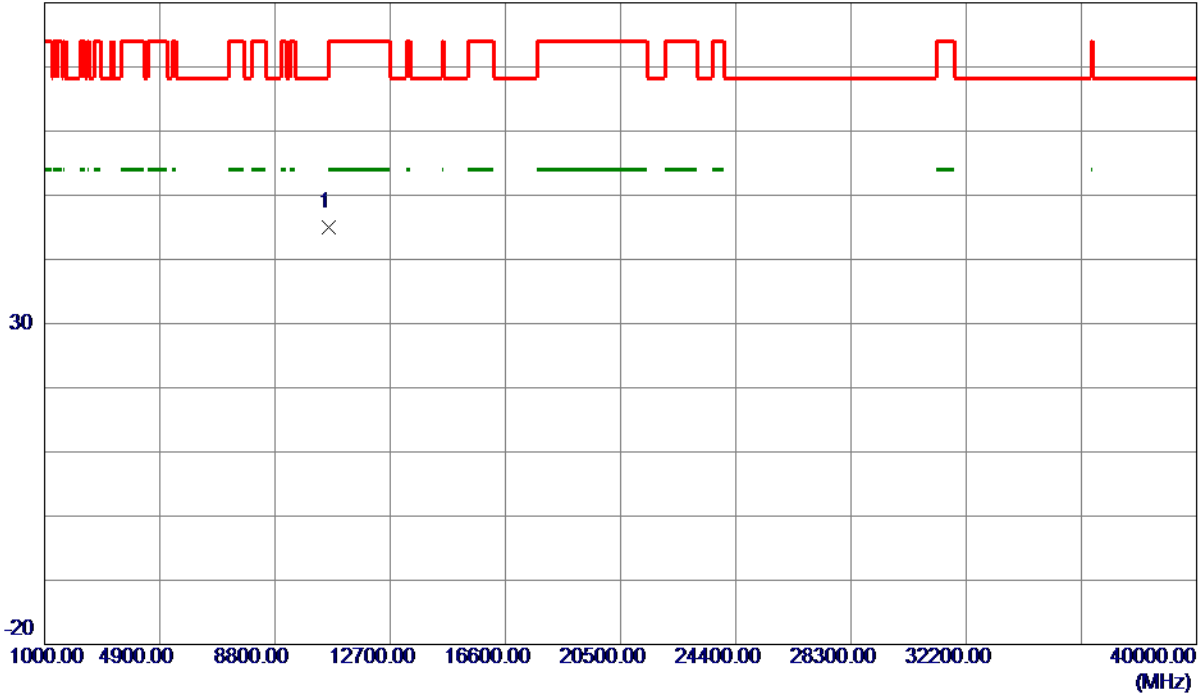

No.	Freq. MHz	Reading Level dBuV/m	Correct Factor dB	Measure ment dBuV/m	Limit dBuV/m	Margin dB	Detector	Comment
1 *	10598.4920	48.12	-3.12	45.00	68.30	-23.30	Peak	

REMARKS:

- (1) Measurement Value = Reading Level + Correct Factor.
- (2) Margin Level = Measurement Value - Limit Value.

Orthogonal Axis	X
Test Mode	UNII-2A_TX AC (VHT20) Mode 5320 MHz

Vertical

130 dBuV/m

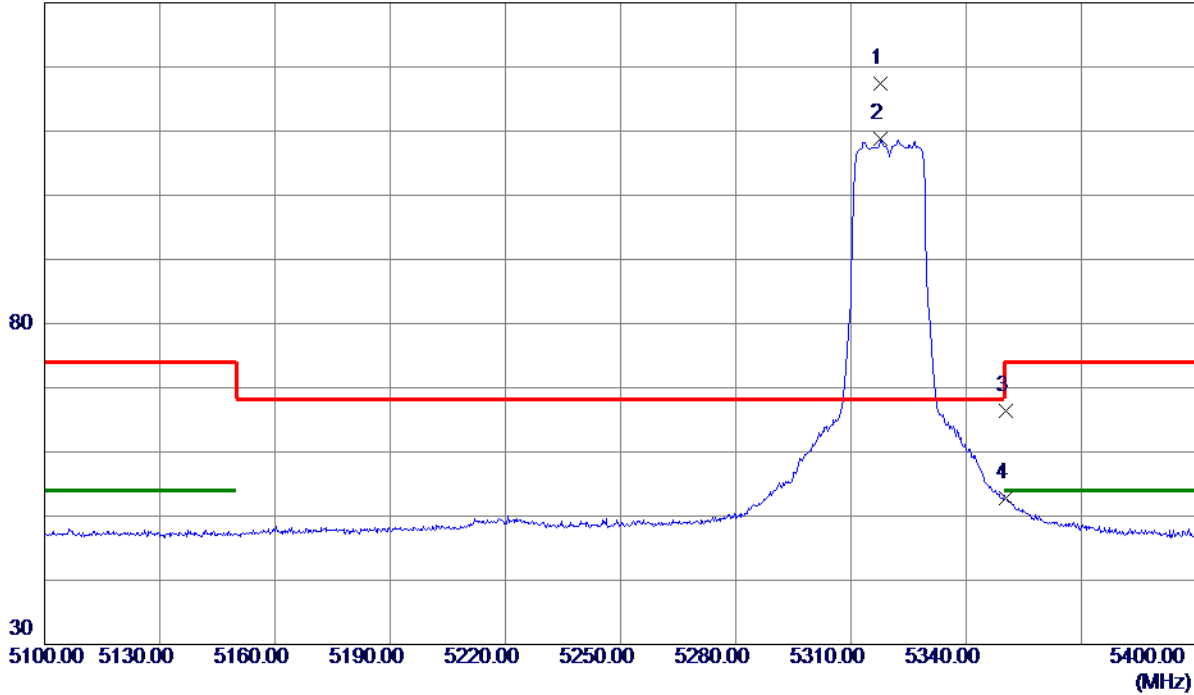

No.	Freq. MHz	Reading Level dBuV/m	Correct Factor dB	Measure ment dBuV/m	Limit dBuV/m	Margin dB	Detector	Comment
1 *	5317.8000	79.82	37.61	117.43	68.30	49.13	Peak	
2	5317.8000	71.20	37.61	108.81	999.00	-890.19	AVG	
3	5350.2000	28.73	37.74	66.47	74.00	-7.53	Peak	
4	5350.2000	14.98	37.74	52.72	54.00	-1.28	AVG	

REMARKS:

- (1) Measurement Value = Reading Level + Correct Factor.
- (2) Margin Level = Measurement Value - Limit Value.

Orthogonal Axis	X
Test Mode	UNII-2A_TX AC (VHT20) Mode 5320 MHz

Vertical

80 dBuV/m

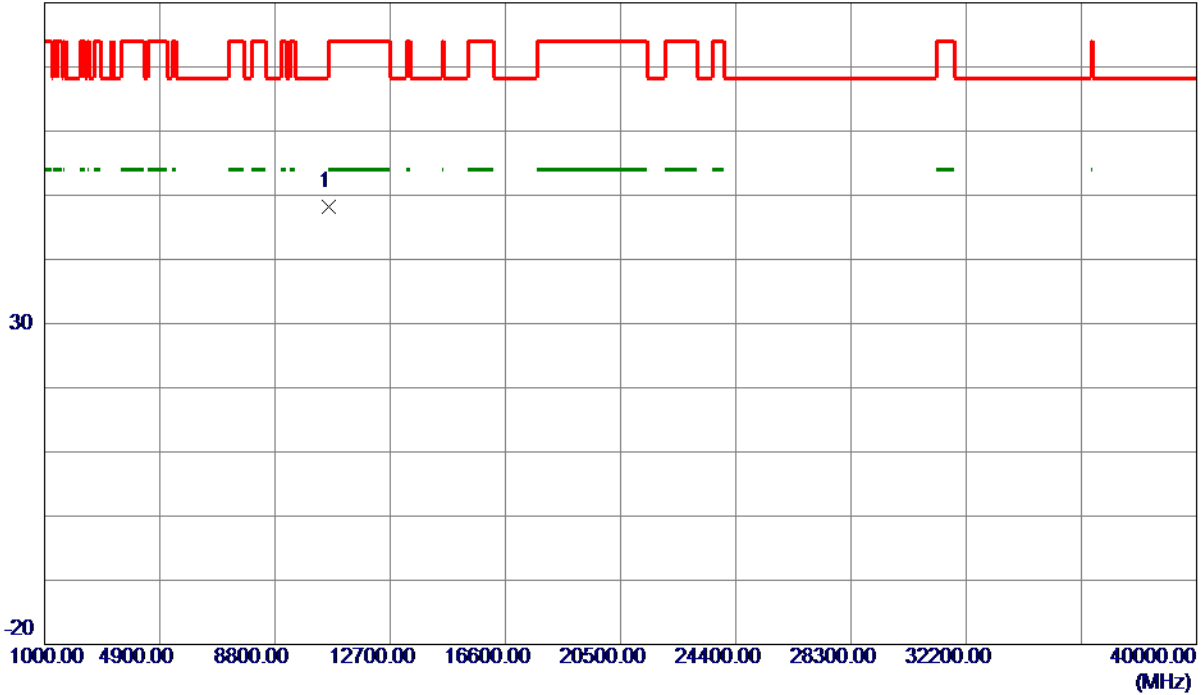

No.	Freq. MHz	Reading Level dBuV/m	Correct Factor dB	Measure ment dBuV/m	Limit dBuV/m	Margin dB	Detector	Comment
1 *	10640.0679	51.23	-3.08	48.15	74.00	-25.85	Peak	

REMARKS:

- (1) Measurement Value = Reading Level + Correct Factor.
- (2) Margin Level = Measurement Value - Limit Value.

Orthogonal Axis	X
Test Mode	UNII-2A_TX AC (VHT20) Mode 5320 MHz

Horizontal

130 dBuV/m

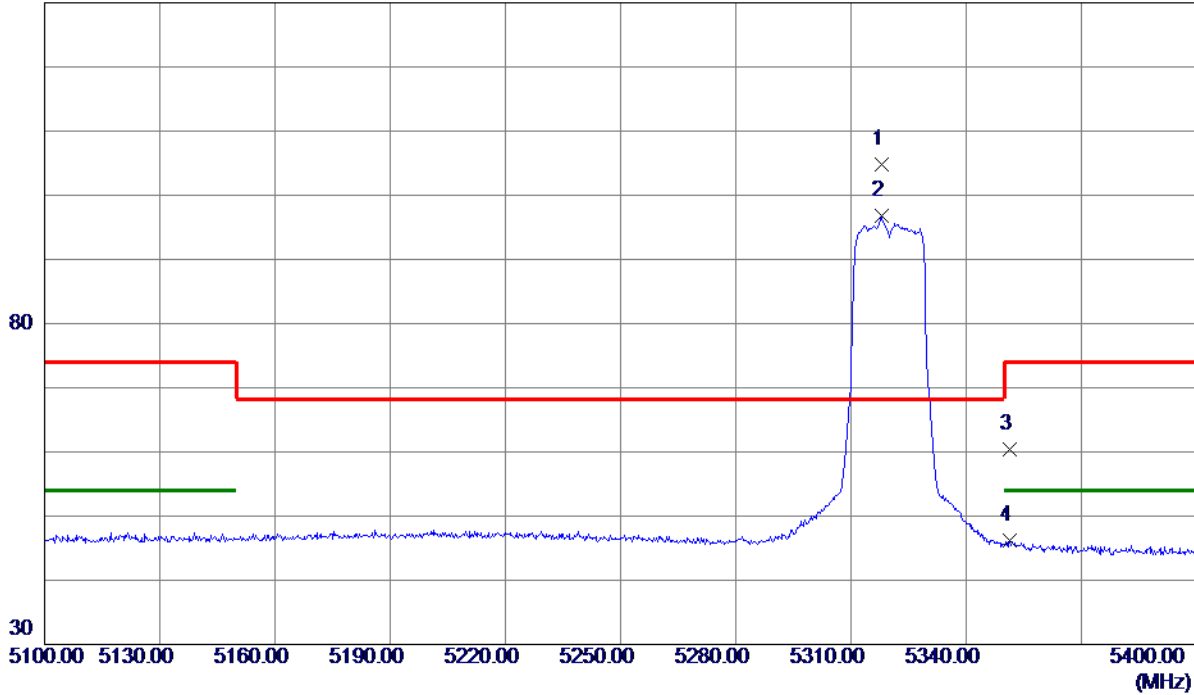

No.	Freq. MHz	Reading Level dBuV/m	Correct Factor dB	Measure ment dBuV/m	Limit dBuV/m	Margin dB	Detector	Comment
1 *	5317.9500	67.24	37.61	104.85	68.30	36.55	Peak	
2	5317.9500	59.12	37.61	96.73	999.00	-902.27	AVG	
3	5351.4000	22.62	37.74	60.36	74.00	-13.64	Peak	
4	5351.4000	8.46	37.74	46.20	54.00	-7.80	AVG	

REMARKS:

- (1) Measurement Value = Reading Level + Correct Factor.
- (2) Margin Level = Measurement Value - Limit Value.