

FCC Radio Test Report

FCC ID: KA2IRX1870A1

This report concerns: Original Grant

Project No. : 2007H027
Equipment : AX1800 Mesh Wi-Fi 6 Router
Brand Name : D-Link
Test Model : DIR-X1870
Series Model : N/A
Applicant : D-Link Corporation
Address : 17595 Mt. Herrmann, Fountain Valley, California United State 92708
Manufacturer : D-Link Corporation
Address : 17595 Mt. Herrmann, Fountain Valley, California United State 92708
Date of Receipt : Jul. 16, 2020
Date of Test : Jul. 16, 2020~Aug. 28, 2020
Issued Date : Sep. 10, 2020
Report Version : R01
Test Sample : Engineering Sample No.: SH20200716113-1, SH20200716113-6
Standard(s) : FCC Part15, Subpart C (15.247)
ANSI C63.10-2013
KDB 558074 D01 15.247 Meas Guidance v05r02
KDB 662911 D01 Multiple Transmitter Output v02r01

The above equipment has been tested and found compliance with the requirement of the relative standards by BTL Inc.

Allen Wei

Prepared by : Allen Wei

Ryan Wang

Approved by : Ryan Wang

Add: No. 29, Jintang Road, Tangzhen Industry Park, Pudong New Area, Shanghai 201210, China

TEL: +86-021-61765666

Web: www.newbtl.com



Certificate # 5123.03

Declaration

BTL represents to the client that testing is done in accordance with standard procedures as applicable and that test instruments used has been calibrated with standards traceable to international standard(s) and/or national standard(s).

BTL's reports apply only to the specific samples tested under conditions. It is manufacture's responsibility to ensure that additional production units of this model are manufactured with the identical electrical and mechanical components. **BTL** shall have no liability for any declarations, inferences or generalizations drawn by the client or others from **BTL** issued reports.

The report must not be used by the client to claim product certification, approval, or endorsement by NVLAP, NIST, A2LA, or any agency of the U.S. Government.

This report is the confidential property of the client. As a mutual protection to the clients, the public and ourselves, the test report shall not be reproduced, except in full, without our written approval.

BTL's laboratory quality assurance procedures are in compliance with the **ISO/IEC 17025** requirements, and accredited by the conformity assessment authorities listed in this test report.

BTL is not responsible for the sampling stage, so the results only apply to the sample as received.

The information, data and test plan are provided by manufacturer which may affect the validity of results, so it is manufacturer's responsibility to ensure that the apparatus meets the essential requirements of applied standards and in all the possible configurations as representative of its intended use.

Limitation

For the use of the authority's logo is limited unless the Test Standard(s)/Scope(s)/Item(s) mentioned in this test report is (are) included in the conformity assessment authorities acceptance respective.

Please note that the measurement uncertainty is provided for informational purpose only and are not use in determining the Pass/Fail results.

Table of Contents	Page
REPORT ISSUED HISTORY	6
1 . SUMMARY OF TEST RESULTS	7
1.1 TEST FACILITY	8
1.2 MEASUREMENT UNCERTAINTY	8
1.3 TEST ENVIRONMENT CONDITIONS	8
2 . GENERAL INFORMATION	9
2.1 GENERAL DESCRIPTION OF EUT	9
2.2 DESCRIPTION OF TEST MODES	11
2.3 PARAMETERS OF TEST SOFTWARE	12
2.4 DUTY CYCLE	13
2.5 BLOCK DIAGRAM SHOWING THE CONFIGURATION OF SYSTEM TESTED	14
2.6 SUPPORT UNITS	14
3 . AC POWER LINE CONDUCTED EMISSIONS TEST	15
3.1 LIMIT	15
3.2 TEST PROCEDURE	15
3.3 DEVIATION FROM TEST STANDARD	15
3.4 TEST SETUP	16
3.5 EUT OPERATION CONDITIONS	16
3.6 TEST RESULTS	16
4 . RADIATED EMISSIONS TEST	17
4.1 LIMIT	17
4.2 TEST PROCEDURE	18
4.3 DEVIATION FROM TEST STANDARD	18
4.4 TEST SETUP	19
4.5 EUT OPERATION CONDITIONS	20
4.6 TEST RESULTS - 9 KHZ TO 30 MHZ	21
4.7 TEST RESULTS - 30 MHZ TO 1000 MHZ	21
4.8 TEST RESULTS - ABOVE 1000 MHZ	21
5 . BANDWIDTH TEST	22
5.1 LIMIT	22
5.2 TEST PROCEDURE	22
5.3 DEVIATION FROM STANDARD	22
5.4 TEST SETUP	22

Table of Contents	Page
5.5 EUT OPERATION CONDITIONS	22
5.6 TEST RESULTS	22
6 . MAXIMUM OUTPUT POWER TEST	23
6.1 LIMIT	23
6.2 TEST PROCEDURE	23
6.3 DEVIATION FROM STANDARD	23
6.4 TEST SETUP	23
6.5 EUT OPERATION CONDITIONS	23
6.6 TEST RESULTS	23
7 . CONDUCTED SPURIOUS EMISSIONS	24
7.1 LIMIT	24
7.2 TEST PROCEDURE	24
7.3 DEVIATION FROM STANDARD	24
7.4 TEST SETUP	24
7.5 EUT OPERATION CONDITIONS	24
7.6 TEST RESULTS	24
8 . POWER SPECTRAL DENSITY TEST	25
8.1 LIMIT	25
8.2 TEST PROCEDURE	25
8.3 DEVIATION FROM STANDARD	25
8.4 TEST SETUP	25
8.5 EUT OPERATION CONDITIONS	25
8.6 TEST RESULTS	25
9 . MEASUREMENT INSTRUMENTS LIST	26
10 . EUT TEST PHOTO	28
APPENDIX A - AC POWER LINE CONDUCTED EMISSIONS	31
APPENDIX B - RADIATED EMISSION - 9 KHZ TO 30 MHZ	34
APPENDIX C - RADIATED EMISSION - 30 MHZ TO 1000 MHZ	35
APPENDIX D - RADIATED EMISSION- ABOVE 1000 MHZ	38
APPENDIX E - BANDWIDTH	63
APPENDIX F - MAXIMUM OUTPUT POWER	66
APPENDIX G - CONDUCTED SPURIOUS EMISSIONS	71

Table of Contents**Page****APPENDIX H - POWER SPECTRAL DENSITY****76**

REPORT ISSUED HISTORY

Report Version	Description	Issued Date
R00	Original Issue.	Sep. 08, 2020
R01	Revised report to address TCB's comments.	Sep. 10, 2020

1. SUMMARY OF TEST RESULTS

Test procedures according to the technical standard(s):

FCC Part15, Subpart C (15.247)				
Standard(s) Section	Test Item	Test Result	Judgment	Remark
15.207	AC Power Line Conducted Emissions	APPENDIX A	PASS	-----
15.247(d) 15.205(a) 15.209(a)	Radiated Emissions	APPENDIX B APPENDIX C APPENDIX D	PASS	-----
15.247(a)(2)	Bandwidth	APPENDIX E	PASS	-----
15.247(b)(3)	Maximum Output Power	APPENDIX F	PASS	-----
15.247(d)	Conducted Spurious Emissions	APPENDIX G	PASS	-----
15.247(e)	Power Spectral Density	APPENDIX H	PASS	-----
15.203	Antenna Requirement	-----	PASS	Note(2)

Note:

- (1) "N/A" denotes test is not applicable in this test report.
- (2) The device what use a permanently attached antenna were considered sufficient to comply with the provisions of 15.203.

1.1 TEST FACILITY

The test facilities used to collect the test data in this report is at the location of No. 29, Jintang Road, Tangzhen Industry Park, Pudong New Area, Shanghai 201210, China
 BTL's Test Firm Registration Number for FCC: 476765
 BTL's Designation Number for FCC: CN1241

1.2 MEASUREMENT UNCERTAINTY

ISO/IEC 17025 requires that an estimate of the measurement uncertainties associated with the emissions test results be included in the report. The measurement uncertainties given below are based on a 95% confidence level (based on a coverage factor (k=2))
 The BTL measurement uncertainty as below table:

A. Radiated emissions test:

Test Site	Method	Measurement Frequency Range	Ant. H / V	U, (dB)
SH-CB01	CISPR	9 KHz~30 MHz	V	3.79
		9 KHz~30 MHz	H	3.57
		30 MHz~200 MHz	V	4.04
		30 MHz~200 MHz	H	3.76
		200 MHz~1,000 MHz	V	4.24
		200 MHz~1,000 MHz	H	3.84
		1 GHz~18 GHz	V	4.46
		1 GHz~18 GHz	H	4.40
		18 GHz~40 GHz	V	3.95
		18 GHz~40 GHz	H	3.95

Note: Unless specifically mentioned, the uncertainty of measurement has not been taken into account to declare the compliance or non-compliance to the specification.

1.3 TEST ENVIRONMENT CONDITIONS

Test Item	Temperature	Humidity	Test Voltage	Tested By
AC Power Line Conducted Emissions	23°C	52%	AC 120V/60Hz	Forest
Radiated Emissions-30 MHz to 1GHz	23°C	52%	AC 120V/60Hz	Forest
Radiated Emissions-Above 1000 MHz	23°C	52%	AC 120V/60Hz	Forest
Bandwidth	24°C	56%	AC 120V/60Hz	Forest
Maximum output power	24°C	56%	AC 120V/60Hz	Forest
Conducted Spurious Emissions	24°C	56%	AC 120V/60Hz	Forest
Power Spectral Density	24°C	56%	AC 120V/60Hz	Forest

2. GENERAL INFORMATION

2.1 GENERAL DESCRIPTION OF EUT

Equipment	AX1800 Mesh Wi-Fi 6 Router
Brand Name	D-Link
Test Model	DIR-X1870
Series Model	N/A
Model Difference(s)	N/A
Software Version	1
Hardware Version	A1
Power Source	DC voltage supplied from AC/DC adapter. 1#Brand/Mode: S12A12-120A100-CJ 2#Brand/Mode: WB-12G12R
Power Rating	1# I/P: 100V-240V ~ 50Hz/60Hz Max0.5A, O/P:12V === 1A. 2# I/P: 100V-240V ~ 50Hz/60Hz 0.3A Max, O/P:12V === 1.0A.12W
Operation Frequency	2412 MHz ~ 2462 MHz
Modulation Type	OFDM,OFDMA
Bit Rate of Transmitter	Up to 574Mbps
Maximum Avg Output Power CDD	IEEE 802.11ax (HE20): 24.21 dBm (0.2636 W) IEEE 802.11ax (HE40): 20.22 dBm (0.1052 W)
Maximum Avg Output Power Beamforming	IEEE 802.11ax (HE20): 24.14 dBm (0.1300 W) IEEE 802.11ax (HE40): 20.17 dBm (0.1040 W)

Note:

- For a more detailed features description, please refer to the manufacturer's specifications or the user's manual.
- Channel List:

CH01 - CH11 for IEEE 802.11ax (HE20) CH03 - CH09 for IEEE 802.11ax (HE40)							
Channel	Frequency (MHz)	Channel	Frequency (MHz)	Channel	Frequency (MHz)	Channel	Frequency (MHz)
01	2412	04	2427	07	2442	10	2457
02	2417	05	2432	08	2447	11	2462
03	2422	06	2437	09	2452		

4. Antenna Specification:

Ant.	Brand	Model Name	Antenna Type	Connector	Gain (dBi)
1	N/A	N/A	Dipole	N/A	5
2	N/A	N/A	Dipole	N/A	5

Note:

(1) Beamforming:

All antennas have the same gain, Directional gain = $G_{ANT} + 10 \log(N_{ANT})$ dBi,

that is Directional gain = $5 + 10 \log(2)$ dBi = 8.01;

So output power limit is $30 - 8.01 + 6 = 27.99$, the power density limit is $8 - (8.01 - 6) = 5.99$.

(2) CDD:

All antennas have the same gain, Directional gain = $G_{ANT} + \text{Array Gain}$,

For power spectral density measurements, $N_{ANT} = 2$, $N_{SS} = 1$. So Directional gain = $G_{ANT} + \text{Array Gain} = 10 \log(N_{ANT}/N_{SS})$ dB = $5 + 10 \log(2/1)$ dBi = 8.01. Then, the power density limit is $8 - (8.01 - 6) = 5.99$.

For power measurements, Array Gain = 0 dB ($N_{ANT} \leq 4$), so the Directional gain = 5.

5. Table for Antenna Configuration:

Operating Mode TX Mode	Ant. 1	Ant. 2	Ant. 1 + Ant. 2
	IEEE 802.11ax (HE20)	✓	✓
IEEE 802.11ax (HE40)	✓	✓	✓

2.2 DESCRIPTION OF TEST MODES

The test system was pre-tested based on the consideration of all possible combinations of EUT operation mode.

Pretest Mode	Description
Mode 1	TX AX-20 Mode Channel 01/06/11
Mode 2	TX AX-40 Mode Channel 01/06/11
Mode 3	TX Mode

Following mode(s) as (were) found to be the worst case(s) and selected for the final test.

AC power line conducted emissions test	
Final Test Mode:	Description
Mode 5	TX Mode

Radiated emissions test - Below 1GHz	
Final Test Mode:	Description
Mode 5	TX Mode

Radiated emissions test- Above 1GHz	
Final Test Mode:	Description
Mode 1	TX AX-20 Mode Channel 01/06/11
Mode 2	TX AX-40 Mode Channel 01/06/11

Conducted test	
Final Test Mode:	Description
Mode 1	TX AX-20 Mode Channel 01/06/11
Mode 2	TX AX-40 Mode Channel 01/06/11

NOTE:

- (1) The measurements are performed at the high, middle, low available channels.
- (2) 802.11n HT20 mode : BPSK (13 Mbps)
802.11n HT40 mode : BPSK (27 Mbps)
For radiated emission tests, the highest output powers were set for final test.
- (3) For conducted emissions and radiated emission below 1 GHz test, two power adapter has been pre-tested, but only the worst case recorded in this report.

2.3 PARAMETERS OF TEST SOFTWARE**CDD**

Test Software	accessMTool.3.1.0.6		
Frequency (MHz)	2412	2437	2462
IEEE 802.11 ax (HE20)	64	82	66
IEEE 802.11 ax (HE40)	58	66	62

Beamforming

Test Software	accessMTool.3.1.0.6		
Frequency (MHz)	2412	2437	2462
IEEE 802.11 ax (HE20)	64	82	66
IEEE 802.11 ax (HE40)	58	66	62

2.4 DUTY CYCLE

If duty cycle is $\geq 98\%$, duty factor is not required.
 If duty cycle is $< 98\%$, duty factor shall be considered.
 The output power = measured power + duty factor.

IEEE 802.11ax (HE20)

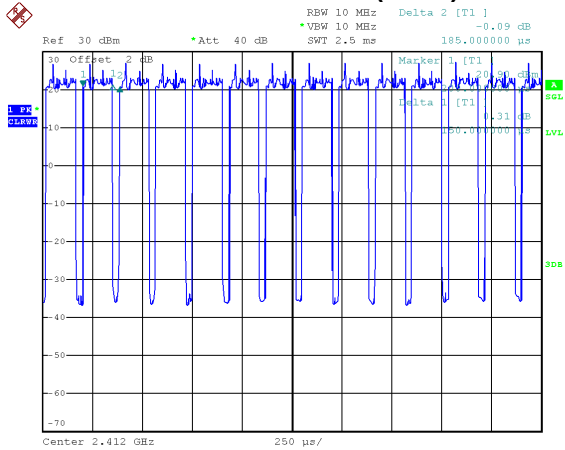

Date: 28.JUL.2020 11:51:34

Duty cycle = $0.150 \text{ ms} / 0.185 \text{ ms} = 81.08\%$
 Duty Factor = $10 \log(1/\text{Duty cycle}) = 0.91$,

IEEE 802.11ax (HE40)

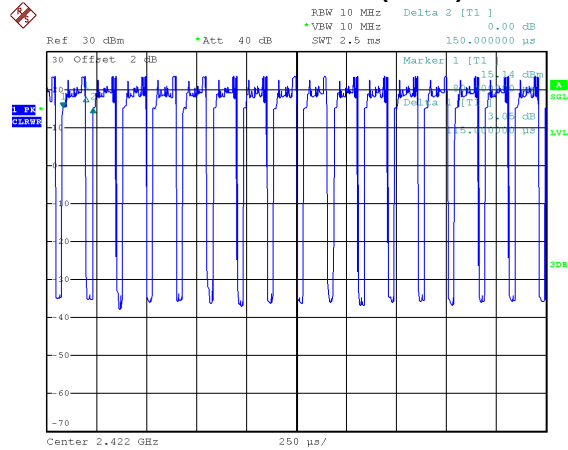

Date: 28.JUL.2020 11:50:25

Duty cycle = $0.115 \text{ ms} / 0.150 \text{ ms} = 76.67\%$
 Duty Factor = $10 \log(1/\text{Duty cycle}) = 1.15$

NOTE:

For IEEE 802.11ax (HE20) and IEEE 802.11ax (HE40):
 For radiated emissions frequency above 1 GHz, the resolution bandwidth of test receiver/spectrum analyzer is 1 MHz and the video bandwidth is 10 kHz (Duty cycle $< 98\%$).

2.5 BLOCK DIAGRAM SHOWING THE CONFIGURATION OF SYSTEM TESTED

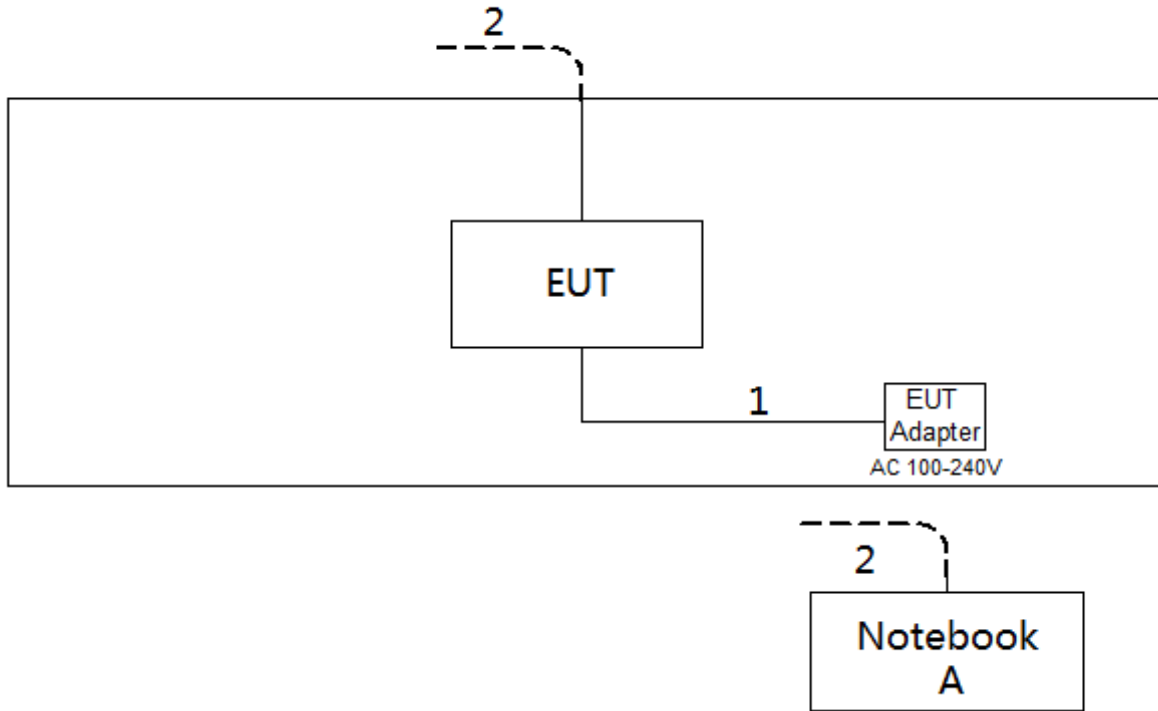

2.6 SUPPORT UNITS

Item	Equipment	Brand	Model No.	Series No.
A	Notebook	Lenovo	#P152014	N/A

Item	Cable Type	Shielded Type	Ferrite Core	Length
1	DC Cable	NO	NO	1.5m
2	RJ45 Cable	NO	NO	10m

3. AC POWER LINE CONDUCTED EMISSIONS TEST

3.1 LIMIT

Frequency of Emission (MHz)	Limit (dB μ V)	
	Quasi-peak	Average
0.15 - 0.50	66 to 56*	56 to 46*
0.50 - 5.0	56	46
5.0 - 30.0	60	50

NOTE:

- (1) The tighter limit applies at the band edges.
- (2) The limit of " * " marked band means the limitation decreases linearly with the logarithm of the frequency in the range.

The following table is the setting of the receiver

Receiver Parameters	Setting
Attenuation	10 dB
Start Frequency	0.15 MHz
Stop Frequency	30 MHz
IF Bandwidth	9 kHz

3.2 TEST PROCEDURE

- a. The EUT was placed 0.8 meters from the horizontal ground plane with EUT being connected to the power mains through a line impedance stabilization network (LISN). All other support equipment powered from additional LISN(s). The LISN provide 50 Ohm/ 50uH of coupling impedance for the measuring instrument.
- b. Interconnecting cables that hang closer than 40 cm to the ground plane shall be folded back and forth in the center forming a bundle 30 to 40 cm long.
- c. I/O cables that are not connected to a peripheral shall be bundled in the center. The end of the cable may be terminated, if required, using the correct terminating impedance. The overall length shall not exceed 1 m.
- d. LISN at least 80 cm from nearest part of EUT chassis.
- e. For the actual test configuration, please refer to the related Item -EUT Test Photos.

3.3 DEVIATION FROM TEST STANDARD

No deviation

3.4 TEST SETUP

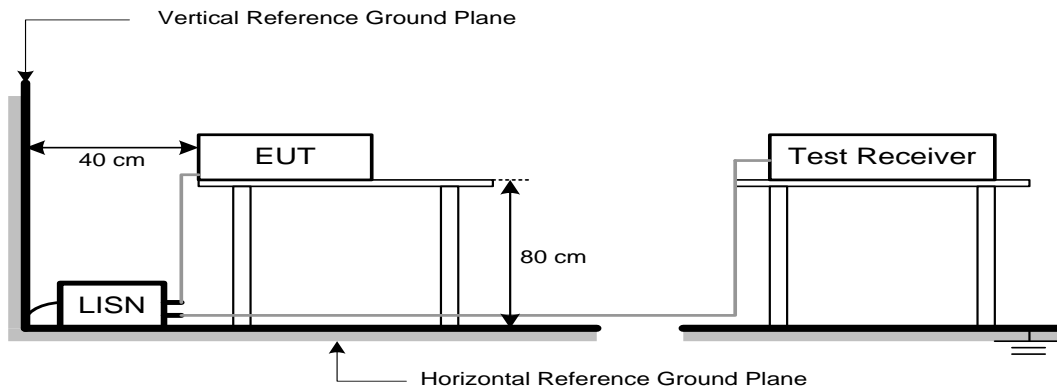

3.5 EUT OPERATION CONDITIONS

EUT was programmed to be in continuously transmitting mode.

3.6 TEST RESULTS

Please refer to the APPENDIX A.

4. RADIATED EMISSIONS TEST

4.1 LIMIT

In case the emission fall within the restricted band specified on 15.205(a), then the 15.209(a) limit in the table below has to be followed.

LIMITS OF RADIATED EMISSION MEASUREMENT (9 kHz-1000 MHz)

Frequency (MHz)	Field Strength (microvolts/meter)	Measurement Distance (meters)
0.009-0.490	2400/F(kHz)	300
0.490-1.705	24000/F(kHz)	30
1.705-30.0	30	30
30-88	100	3
88-216	150	3
216-960	200	3
Above 960	500	3

LIMITS OF RADIATED EMISSION MEASUREMENT (Above 1000 MHz)

Frequency (MHz)	Band edge/ Harmonic at 3m (dB μ V/m)	
	Peak	Average
Above 1000	74	54

NOTE:

- (1) The limit for radiated test was performed according to FCC PART 15C.
- (2) The tighter limit applies at the band edges.
- (3) Emission level (dB μ V/m)=20log Emission level (uV/m).
- (4) The test result calculated as following:
 Measurement Value = Reading Level + Correct Factor
 Correct Factor = Antenna Factor + Cable Loss - Amplifier Gain(if use)
 Margin Level = Measurement Value - Limit Value

Spectrum Parameter	Setting
Attenuation	Auto
Start Frequency	1000 MHz
Stop Frequency	10th carrier harmonic
RBW / VBW (Emission in restricted band)	1 MHz / 3 MHz for Peak, 1 MHz / 1/T for Average

Receiver Parameter	Setting
Attenuation	Auto
Start ~ Stop Frequency	9 kHz~90 kHz for PK/AVG detector
Start ~ Stop Frequency	90 kHz~110 kHz for QP detector
Start ~ Stop Frequency	110 kHz~490 kHz for PK/AVG detector
Start ~ Stop Frequency	490 kHz~30 MHz for QP detector
Start ~ Stop Frequency	30 MHz~1000 MHz for QP detector

4.2 TEST PROCEDURE

- a. The measuring distance of 3 m shall be used for measurements. The EUT was placed on the top of a rotating table 0.8 meter above the ground at a 3 meter semi-anechoic chamber. The table was rotated 360 degrees to determine the position of the highest radiation.(below 1 GHz)
- b. The measuring distance of 3 m shall be used for measurements. The EUT was placed on the top of a rotating table 1.5 meter above the ground at a 3 meter semi-anechoic chamber. The table was rotated 360 degrees to determine the position of the highest radiation.(above 1GHz)
- c. The height of the equipment or of the substitution antenna shall be 0.8m or 1.5m; the height of the test antenna shall vary between 1 m to 4 m. Both horizontal and vertical polarizations of the antenna are set to make the measurement.
- d. For each suspected emission, the EUT was arranged to its worst case and then the antenna was tuned to heights find the maximum reading (used Bore sight function).
- e. The receiver system was set to peak and average detect function and specified bandwidth with maximum hold mode when the test frequency is above 1 GHz.
- f. The initial step in collecting radiated emission data is a receiver peak detector mode pre-scanning the measurement frequency range. Significant peaks are then marked and then Quasi Peak detector mode re-measured.
- g. All readings are Peak unless otherwise stated QP in column of Note. Peak denotes that the Peak reading compliance with the QP Limits and then QP Mode measurement didn't perform.
(below 1 GHz)
- h. All readings are Peak Mode value unless otherwise stated AVG in column of Note. If the Peak Mode Measured value compliance with the Peak Limits and lower than AVG Limits, the EUT shall be deemed to meet both Peak & AVG Limits and then only Peak Mode was measured, but AVG Mode didn't perform. (above 1 GHz)
- i. For the actual test configuration, please refer to the related Item -EUT Test Photos.

4.3 DEVIATION FROM TEST STANDARD

No deviation

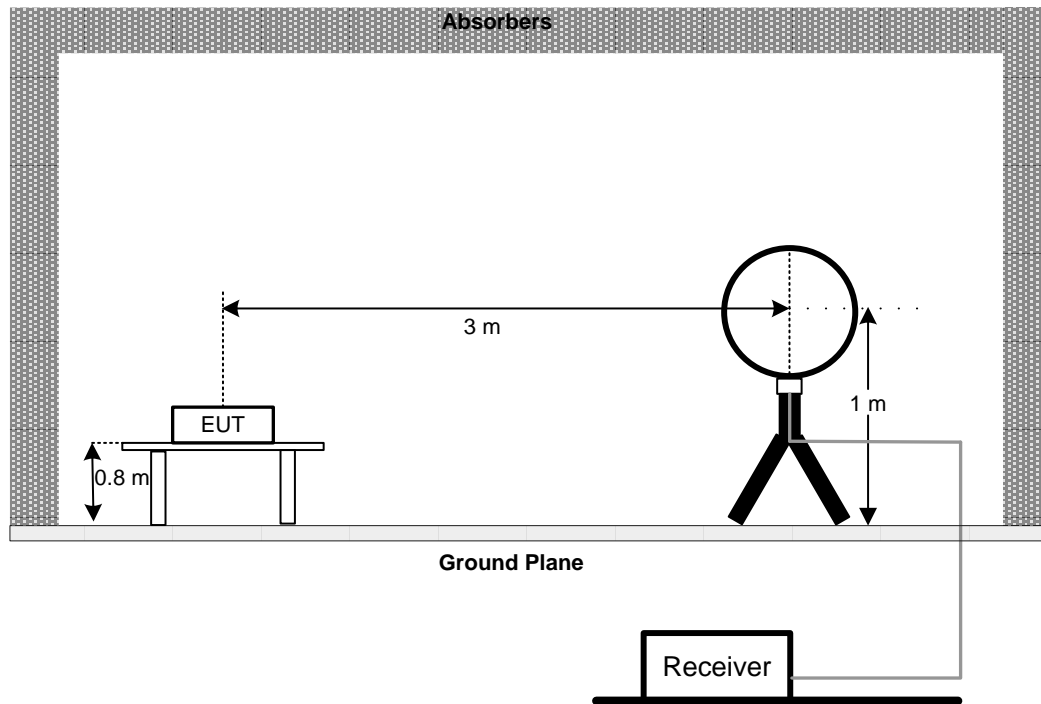
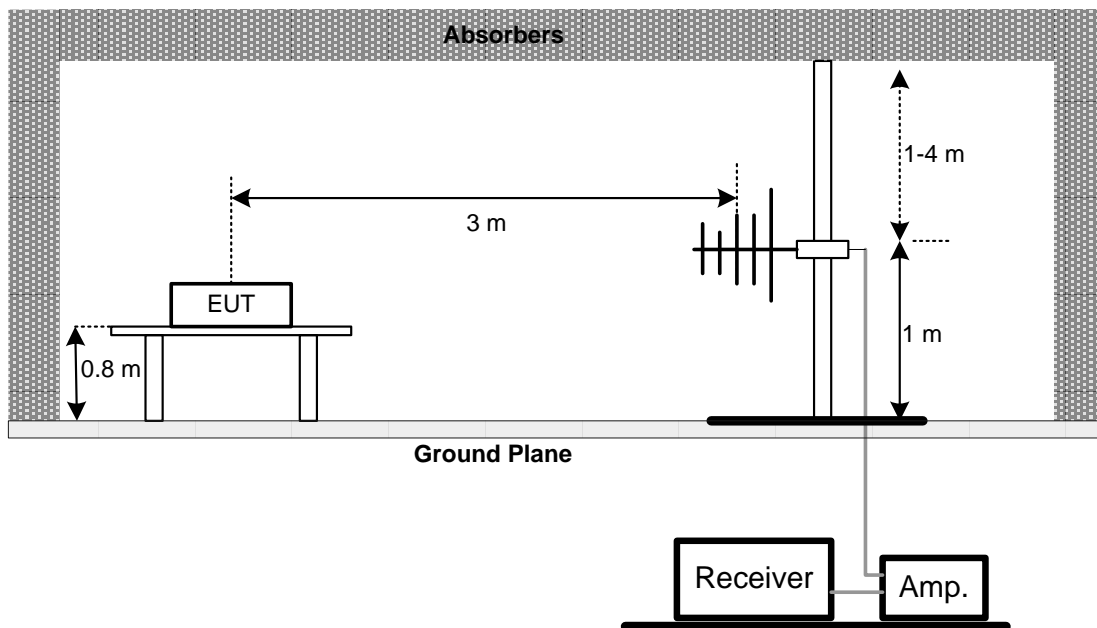
4.4 TEST SETUP**9 kHz-30 MHz****30 MHz to 1 GHz**

**Above 1 GHz
Band edge**

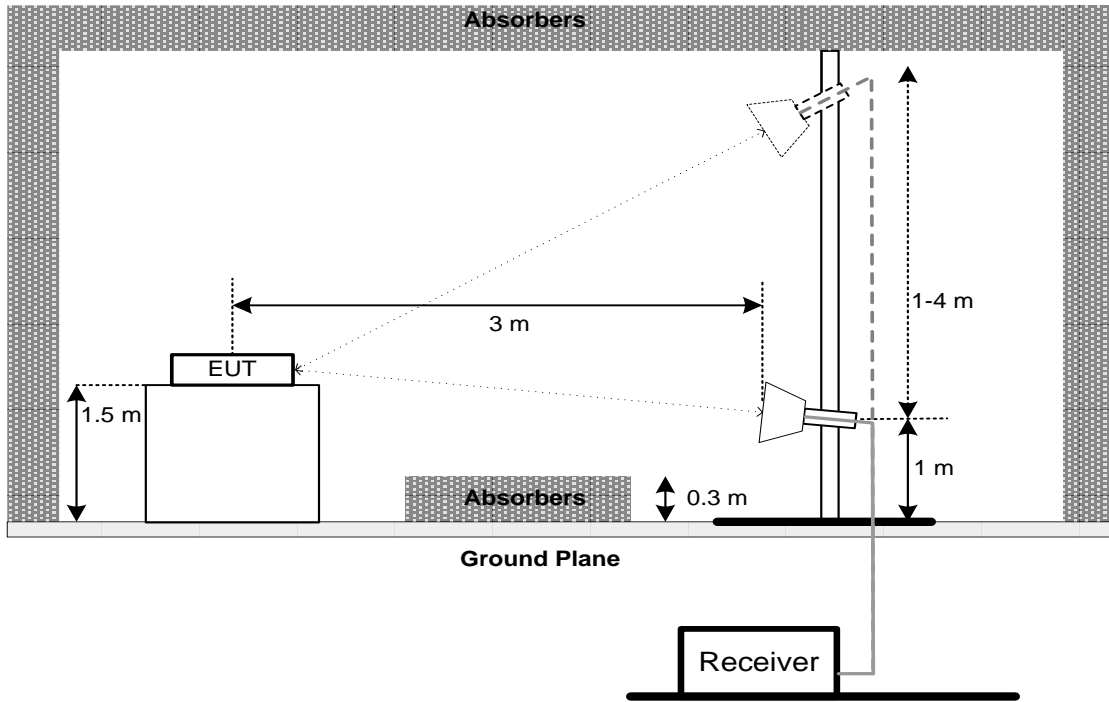

Harmonic

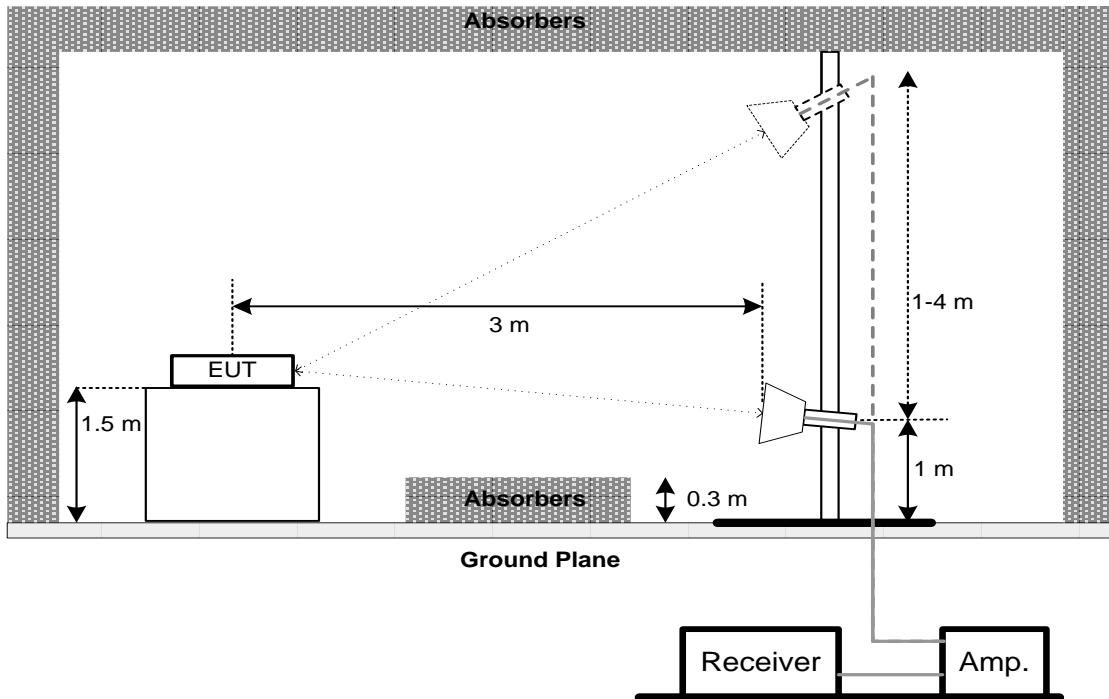

4.5 EUT OPERATION CONDITIONS

The EUT was programmed to be in continuously transmitting mode.

4.6 TEST RESULTS - 9 KHZ TO 30 MHZ

Please refer to the APPENDIX B

Remark:

- (1) Distance extrapolation factor = $40 \log (\text{specific distance} / \text{test distance})$ (dB).
- (2) Limit line = specific limits (dBuV) + distance extrapolation factor.

4.7 TEST RESULTS - 30 MHZ TO 1000 MHZ

Please refer to the APPENDIX C.

4.8 TEST RESULTS - ABOVE 1000 MHZ

Please refer to the APPENDIX D.

Remark:

- (1) No limit: This is fundamental signal, the judgment is not applicable.
For fundamental signal judgment was referred to Peak output test.

5. BANDWIDTH TEST

5.1 LIMIT

FCC Part15, Subpart C (15.247)		
Section	Test Item	Limit
15.247(a)(2)	6 dB Bandwidth	Minimum 500 kHz
	99% Emission Bandwidth	-

5.2 TEST PROCEDURE

- a. The EUT was directly connected to the spectrum analyzer and antenna output port as show in the block diagram below.
- b. Spectrum Setting:
 For 6 dB Bandwidth : RBW= 100 kHz, VBW=300 kHz, Sweep time = auto.
 For 99% Emission Bandwidth B/G/N-20 Mode: RBW= 300 KHz, VBW=1 MHz, Sweep time = 2.5 ms.
 For 99% Emission Bandwidth N-40 Mode: RBW= 1 MHz, VBW=3 MHz, Sweep time = 2.5 ms.
- c. The bandwidth was performed in accordance with method 11.8.1 of ANSI C63.10-2013.

5.3 DEVIATION FROM STANDARD

No deviation.

5.4 TEST SETUP



5.5 EUT OPERATION CONDITIONS

The EUT was programmed to be in continuously transmitting mode.

5.6 TEST RESULTS

Please refer to the APPENDIX E.

6. MAXIMUM OUTPUT POWER TEST

6.1 LIMIT

FCC Part15, Subpart C (15.247)		
Section	Test Item	Limit
15.247(b)(3)	Maximum Output Power	1 Watt or 30dBm

6.2 TEST PROCEDURE

- The EUT was directly connected to the power meter and antenna output port as show in the block diagram below.
- The maximum conducted output power was performed in accordance with method 11.9.1.3 (for peak power) or 11.9.2.3.1 (for AVG power) of ANSI C63.10-2013.

6.3 DEVIATION FROM STANDARD

No deviation.

6.4 TEST SETUP



6.5 EUT OPERATION CONDITIONS

The EUT was programmed to be in continuously transmitting mode.

6.6 TEST RESULTS

Please refer to the APPENDIX F.

7. CONDUCTED SPURIOUS EMISSIONS

7.1 LIMIT

In any 100 kHz bandwidth outside the frequency band in which the spread spectrum or digitally modulated intentional radiator is operating, the radio frequency power that is produced by the intentional radiator shall be at least 20 dB below that in the 100 kHz bandwidth within the band that contains the highest level of the desired power, based on either an RF conducted or a radiated measurement, provided the transmitter demonstrates compliance with the peak Output Power limits. If the transmitter complies with the Output Power limits based on the use of RMS averaging over a time interval, as permitted under paragraph (b)(3) of this section, the attenuation required under this paragraph shall be 30 dB instead of 20 dB. Attenuation below the general limits specified in Section 15.209(a) is not required.

7.2 TEST PROCEDURE

- a. The EUT was directly connected to the spectrum analyzer and antenna output port as show in the block diagram below.
- b. Spectrum Setting: RBW= 100 kHz, VBW=300 kHz, Sweep time = Auto.

7.3 DEVIATION FROM STANDARD

No deviation.

7.4 TEST SETUP

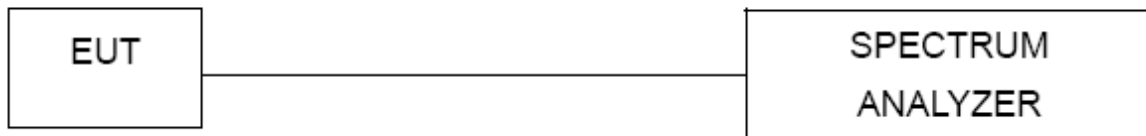

7.5 EUT OPERATION CONDITIONS

The EUT was programmed to be in continuously transmitting mode.

7.6 TEST RESULTS

Please refer to the APPENDIX G.

8. POWER SPECTRAL DENSITY TEST

8.1 LIMIT

FCC Part15, Subpart C (15.247)		
Section	Test Item	Limit
15.247(e)	Power Spectral Density	8 dBm (in any 3 kHz)

8.2 TEST PROCEDURE

- The EUT was directly connected to the spectrum analyzer and antenna output port as show in the block diagram below.
- Spectrum Setting: RBW=3 kHz, VBW=10 kHz, Sweep time = Auto.
- The Power Spectral Density was performed in accordance with method 11.10.2 of ANSI C63.10-2013.

8.3 DEVIATION FROM STANDARD

No deviation.

8.4 TEST SETUP

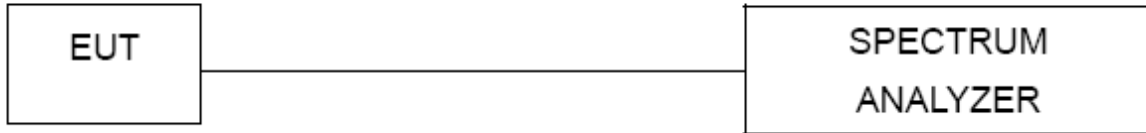

8.5 EUT OPERATION CONDITIONS

The EUT was programmed to be in continuously transmitting mode.

8.6 TEST RESULTS

Please refer to the APPENDIX H.

9. MEASUREMENT INSTRUMENTS LIST

AC Power Line Conducted Emissions					
Item	Kind of Equipment	Manufacturer	Type No.	Serial No.	Calibrated until
1	Line Impedance Stabilisation Network	Schwarzbeck	NNLK 8121	8121-822	Mar. 21, 2021
2	TWO-LINE V-NETWORK	R&S	ENV216	101340	Sep. 01, 2020
3	Test Cable	emci	EMCRG400-BM-N M-10000	170628	Jul. 15, 2021
4	EMI Test Receiver	R&S	ESCI	100082	Mar. 21, 2021
5	50Ω Terminator	SHX	TF2-1G-A	17051602	Mar. 21, 2021
6	50Ω coaxial switch	Anritsu	MP59B	6201750902	Mar. 21, 2021
7	Measurement Software	Farad	EZ-EMC Ver.NB-03A1-01	N/A	N/A

Radiated Emissions - 9 kHz to 30 MHz					
Item	Kind of Equipment	Manufacturer	Type No.	Serial No.	Calibrated until
1	Loop Antenna	EMCI	EMCI LPA600	275	Apr. 02, 2021
2	EMI Test Receiver	R&S	ESCI	100082	Mar. 21, 2021
3	Measurement Software	Farad	EZ-EMC Ver.NB-03A1-01	N/A	N/A

Radiated Emissions - 30 MHz to 1 GHz					
Item	Kind of Equipment	Manufacturer	Type No.	Serial No.	Calibrated until
1	TRILOG Broadband Antenna	Schwarzbeck	VULB 9168	719	Apr. 02, 2021
2	Pre-Amplifier	emci	EMC9135	980400	Mar. 21, 2021
3	MXE EMI Receiver	Keysight	N9038A	MY57150106	May. 06, 2021
4	Test Cable	emci	EMC104-SM-SM-7000	170330	Apr. 13, 2021
5	Test Cable	emci	EMC104-SM-SM-1000	170331	Apr. 13, 2021
6	Test Cable	emci	EMC104-SM-NM-3500	170621	Apr. 13, 2021
7	Measurement Software	Farad	EZ-EMC Ver.NB-03A1-01	N/A	N/A

Radiated Emissions - Above 1 GHz					
Item	Kind of Equipment	Manufacturer	Type No.	Serial No.	Calibrated until
1	Double-Ridged Waveguide Horn Antenna	ETS-Lindgren	9120D	00206960	Apr. 02, 2021
2	Pre-Amplifier	emci	EMC012645SE	980421	May. 11, 2021
3	EXA Spectrum Analyzer	Keysight	N9010A	MY56480545	Mar. 21, 2021
4	Test Cable	emci	EMC104-SM-SM-7000	170330	Apr. 13, 2021
5	Test Cable	emci	EMC104-SM-SM-1000	170331	Apr. 13, 2021
6	Test Cable	emci	EMC104-SM-NM-3500	170621	Apr. 13, 2021
7	Measurement Software	Farad	EZ-EMC Ver.NB-03A1-01	N/A	N/A
8	MXE EMI Receiver	Keysight	N9038A	MY57150106	May. 06, 2021
9	Double-Ridged Waveguide Horn Antenna	ETS-Lindgren	3116C	00203919	Mar. 21, 2021
10	Pre-Amplifier	emci	EMC184045SE	980409	Mar. 21, 2021
11	EXA Spectrum Analyzer	Keysight	N9010A	MY56480579	Mar. 21, 2021
12	Test Cable	emci	EMC102-KM-KM-800	170654	Apr. 13, 2021
13	Test Cable	emci	Super Reliable-40G-SS11-7000	W0030860001	Apr. 13, 2021
14	Measurement Software	Farad	EZ-EMC Ver.NB-03A1-01	N/A	N/A

Bandwidth					
Item	Kind of Equipment	Manufacturer	Type No.	Serial No.	Calibrated until
1	Spectrum Analyzer	R&S	FSP40	100626	May. 06, 2021

Maximum Output Power					
Item	Kind of Equipment	Manufacturer	Type No.	Serial No.	Calibrated until
1	Peak Power Analyze	Keysight	8990B	MY51000507	Mar. 21, 2021
2	Wideband Power Sensor	Keysight	N9123A	MY58310003	Mar. 21, 2021

Antenna Conducted Spurious Emissions					
Item	Kind of Equipment	Manufacturer	Type No.	Serial No.	Calibrated until
1	Spectrum Analyzer	R&S	FSP40	100626	May. 06, 2021

Power Spectral Density					
Item	Kind of Equipment	Manufacturer	Type No.	Serial No.	Calibrated until
1	Spectrum Analyzer	R&S	FSP40	100626	May. 06, 2021

Remark: "N/A" denotes no model name, serial no. or calibration specified.

All calibration period of equipment list is one year.

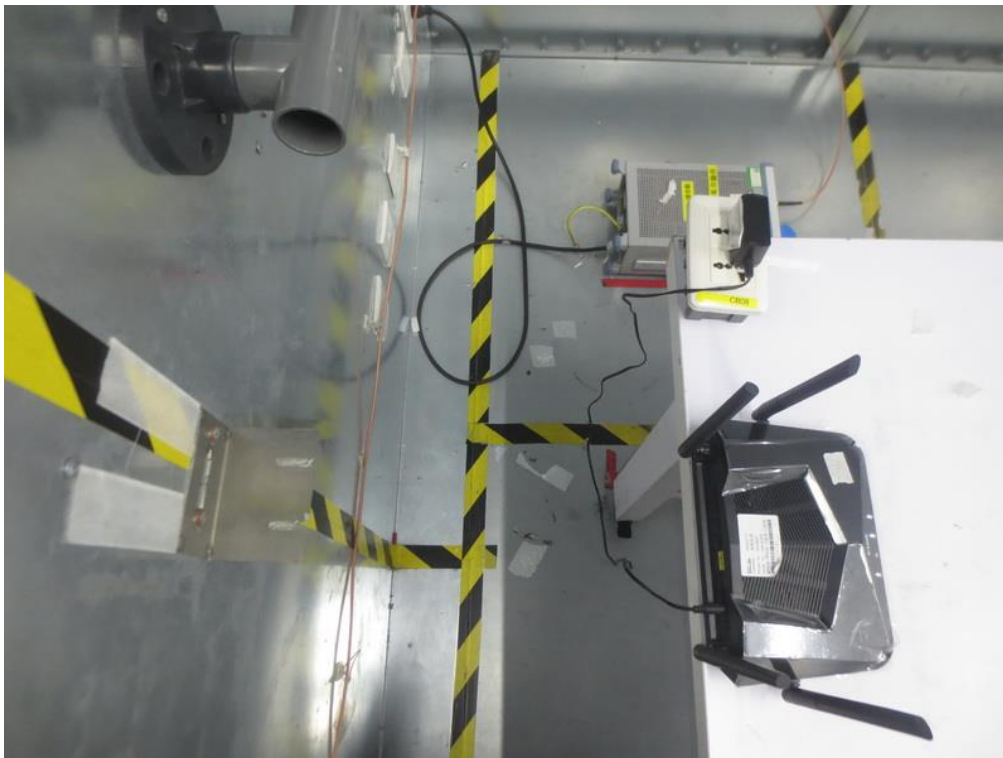
10. EUT TEST PHOTO**Conducted Emissions Test Photos**

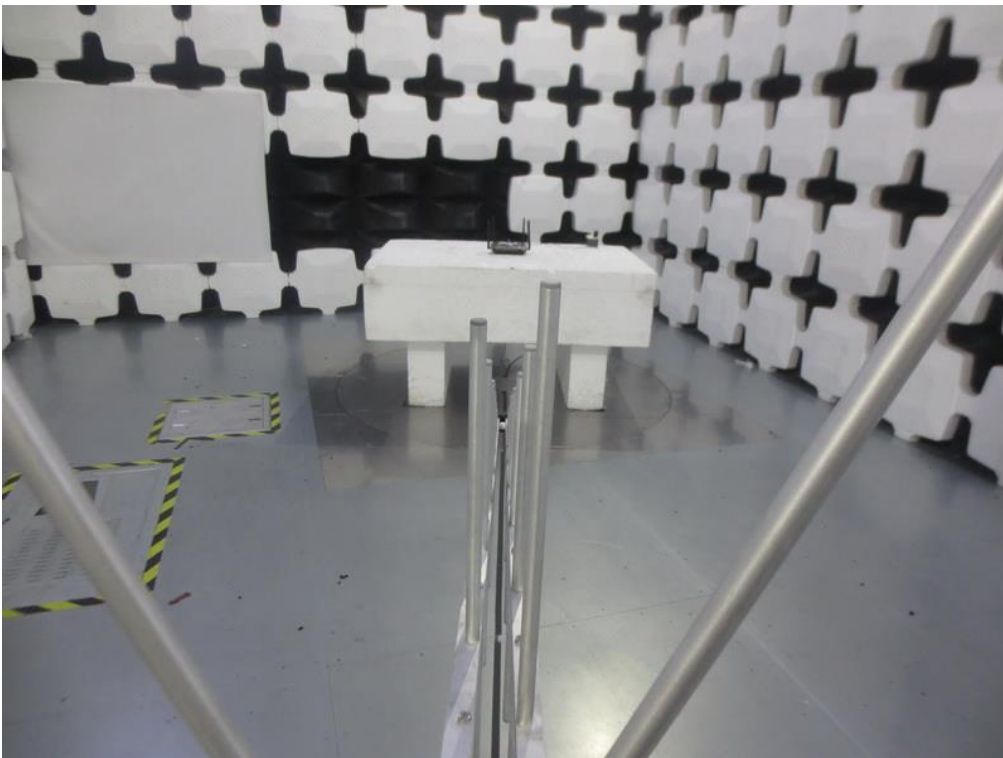
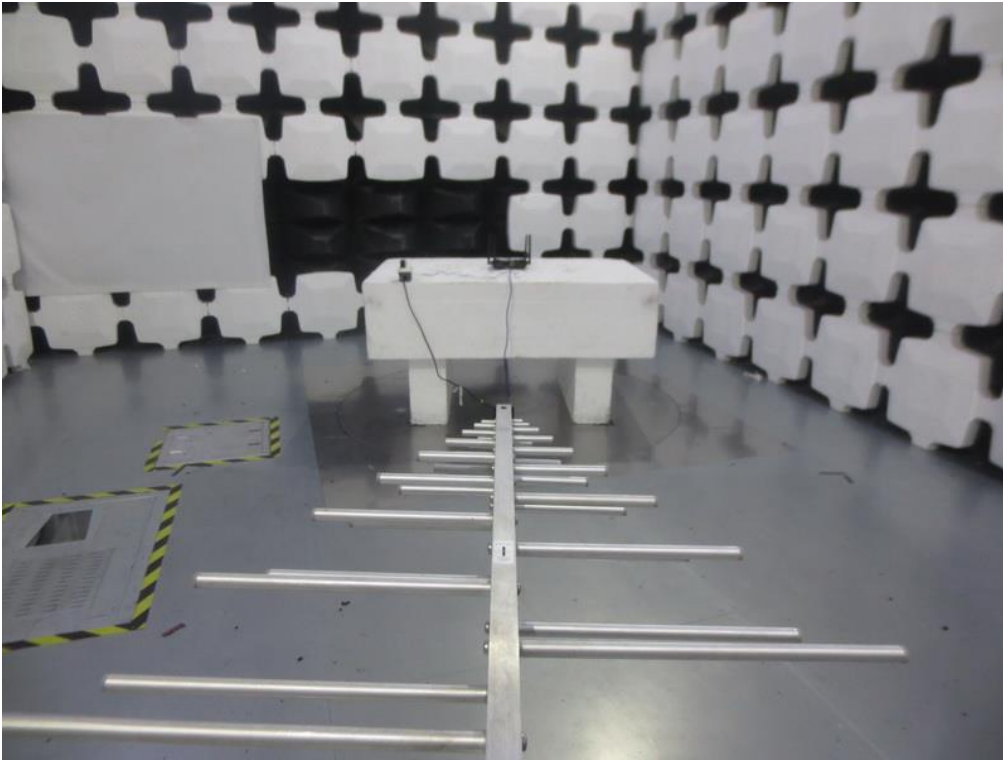
Radiated Emissions Test Photos**30 MHz to 1 GHz**

Radiated Emissions Test Photos

Above 1 GHz

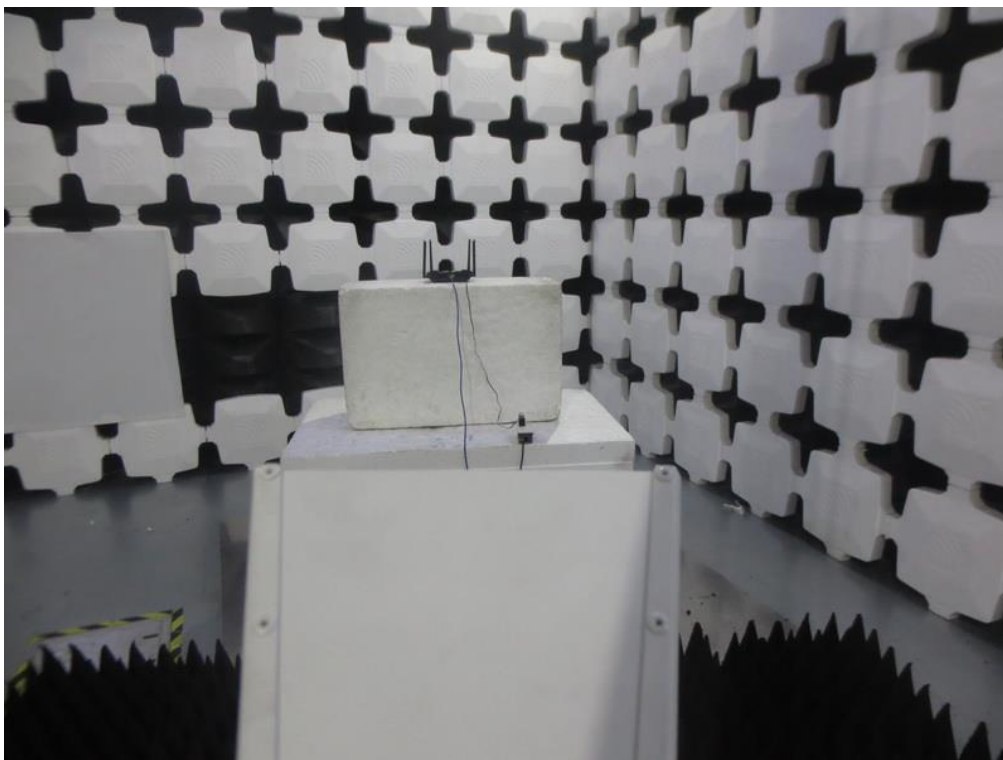

APPENDIX A - AC POWER LINE CONDUCTED EMISSIONS

Test Mode: TX Mode

Line

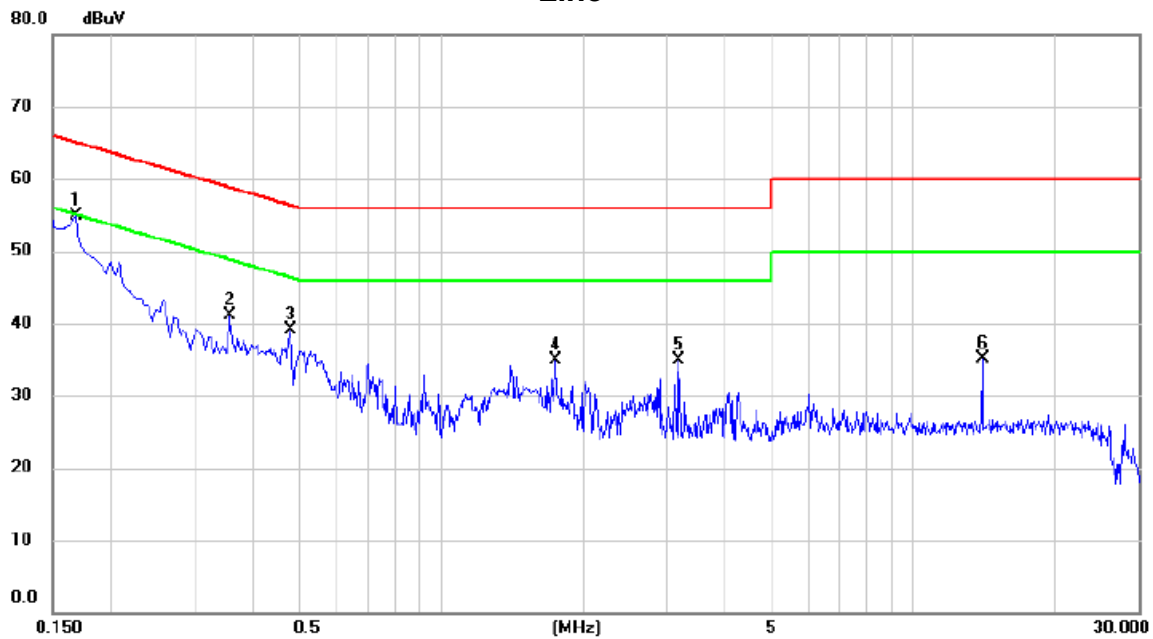

No.	Mk.	Freq. MHz	Reading Level dBuV	Correct Factor dB	Measure- ment dBuV	Limit dBuV	Margin dB	Detector	Comment
1	*	0.1680	45.18	9.74	54.92	65.06	-10.14	peak	
2		0.3570	31.27	9.85	41.12	58.80	-17.68	peak	
3		0.4784	29.27	9.89	39.16	56.37	-17.21	peak	
4		1.7520	25.18	9.79	34.97	56.00	-21.03	peak	
5		3.1920	24.96	9.87	34.83	56.00	-21.17	peak	
6		14.0010	24.82	10.19	35.01	60.00	-24.99	peak	

REMARKS:

- (1) Measurement Value = Reading Level + Correct Factor.
- (2) Margin Level = Measurement Value - Limit Value.

Test Mode: TX Mode

Neutral

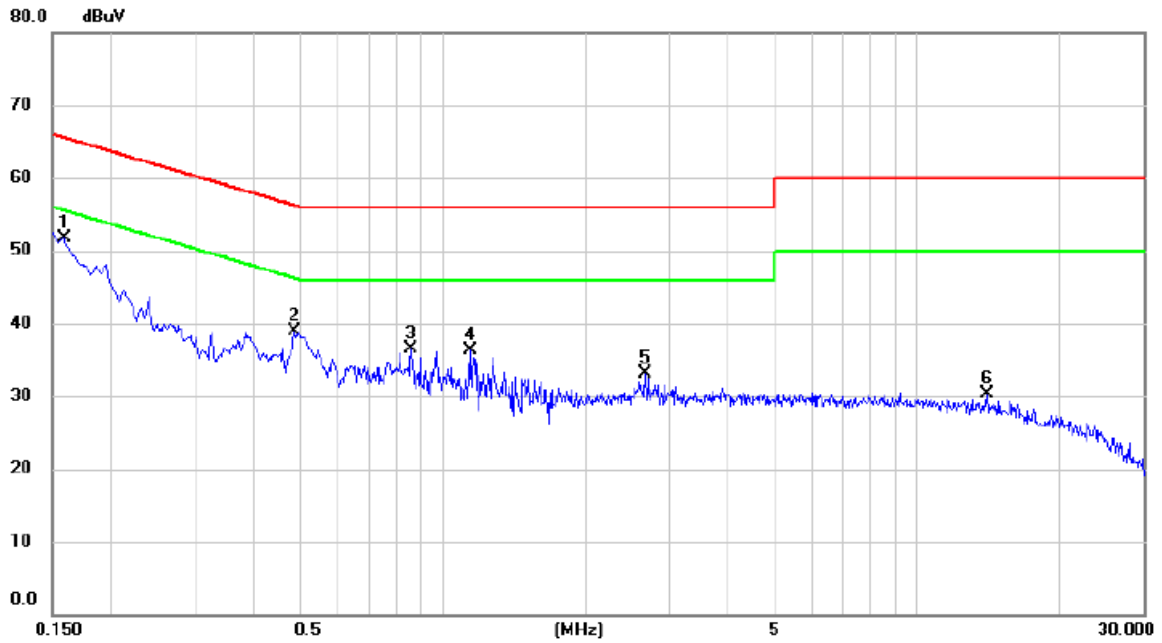

No.	Mk.	Freq. MHz	Reading Level dBuV	Correct Factor dB	Measure- ment dBuV	Limit dBuV	Margin dB	Detector	Comment
1	*	0.1590	42.09	9.61	51.70	65.52	-13.82	peak	
2		0.4874	29.27	9.69	38.96	56.21	-17.25	peak	
3		0.8564	26.79	9.72	36.51	56.00	-19.49	peak	
4		1.1400	26.63	9.73	36.36	56.00	-19.64	peak	
5		2.6700	23.19	9.83	33.02	56.00	-22.98	peak	
6		14.0010	20.06	10.15	30.21	60.00	-29.79	peak	

REMARKS:

- (1) Measurement Value = Reading Level + Correct Factor.
- (2) Margin Level = Measurement Value - Limit Value.

APPENDIX B - RADIATED EMISSION - 9 KHZ TO 30 MHZ

Note: Below 30MHz, The measured value have enough margin over 20dB than the limit,
therefore they are not reported

APPENDIX C - RADIATED EMISSION - 30 MHZ TO 1000 MHZ

Test Mode: TX Mode

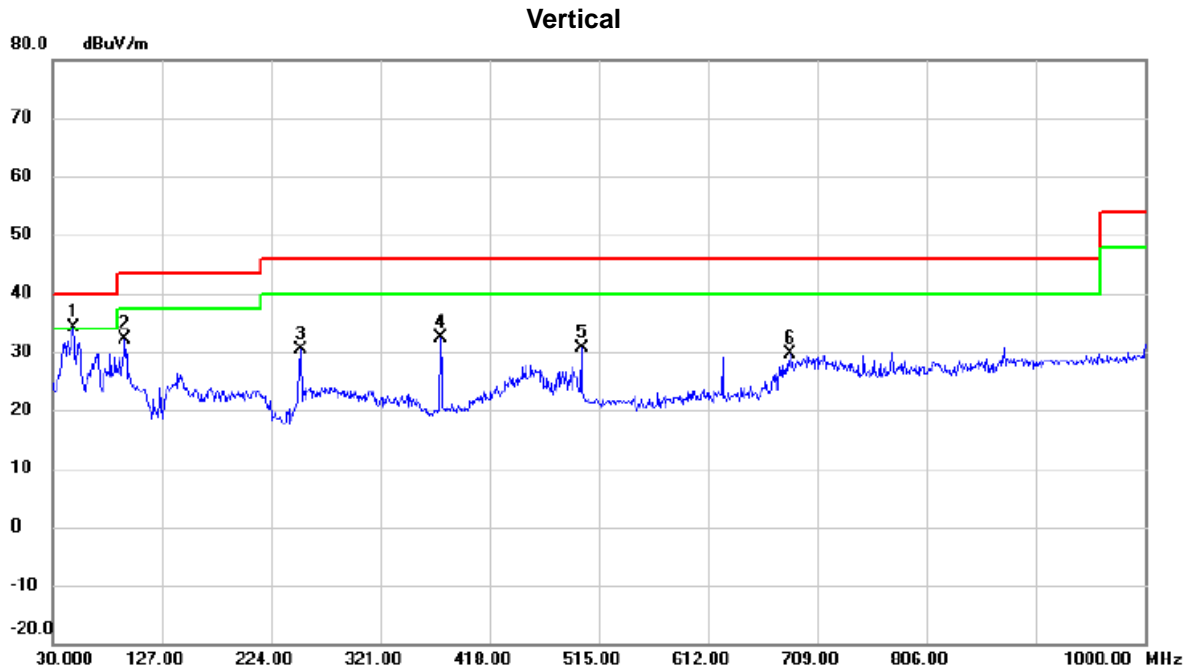

No.	Mk.	Freq. MHz	Reading Level dBuV	Correct Factor dB	Measure- ment dBuV/m	Limit dBuV/m	Margin dB	Detector	Comment
1	*	48.4300	50.59	-16.49	34.10	40.00	-5.90	peak	
2		94.5050	53.49	-21.48	32.01	43.50	-11.49	peak	
3		250.1900	46.93	-16.67	30.26	46.00	-15.74	peak	
4		374.8350	45.47	-13.11	32.36	46.00	-13.64	peak	
5		499.9650	41.05	-10.32	30.73	46.00	-15.27	peak	
6		684.7500	36.58	-6.98	29.60	46.00	-16.40	peak	

REMARKS:

- (1) Measurement Value = Reading Level + Correct Factor.
- (2) Margin Level = Measurement Value - Limit Value.

Test Mode: TX Mode

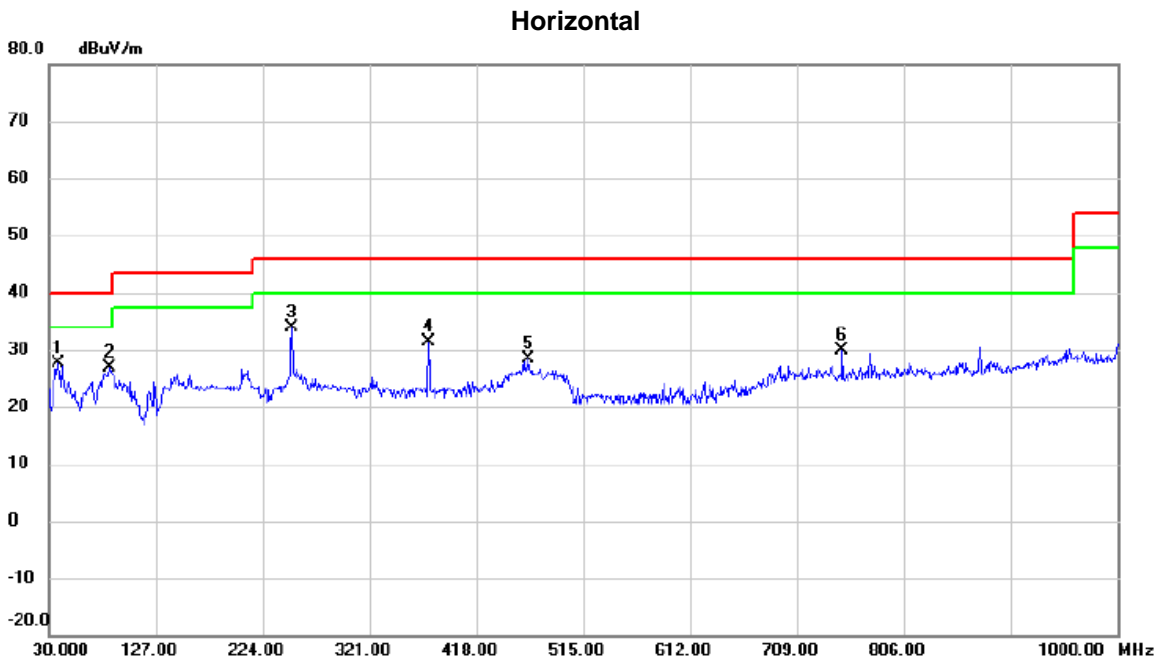

No.	Mk.	Freq. MHz	Reading Level dBuV	Correct Factor dB	Measure- ment dBuV/m	Limit dBuV/m	Margin dB	Detector	Comment
1		38.2450	44.89	-17.35	27.54	40.00	-12.46	peak	
2		84.3200	48.16	-21.34	26.82	40.00	-13.18	peak	
3	*	250.1900	50.54	-16.67	33.87	46.00	-12.13	peak	
4		374.8350	44.53	-13.11	31.42	46.00	-14.58	peak	
5		465.5300	39.15	-10.80	28.35	46.00	-17.65	peak	
6		750.2250	35.62	-5.82	29.80	46.00	-16.20	peak	

REMARKS:
 (1) Measurement Value = Reading Level + Correct Factor.
 (2) Margin Level = Measurement Value - Limit Value.

APPENDIX D - RADIATED EMISSION- ABOVE 1000 MHZ

Test Mode: TX AX (HE20) Mode 2412 MHz

Vertical

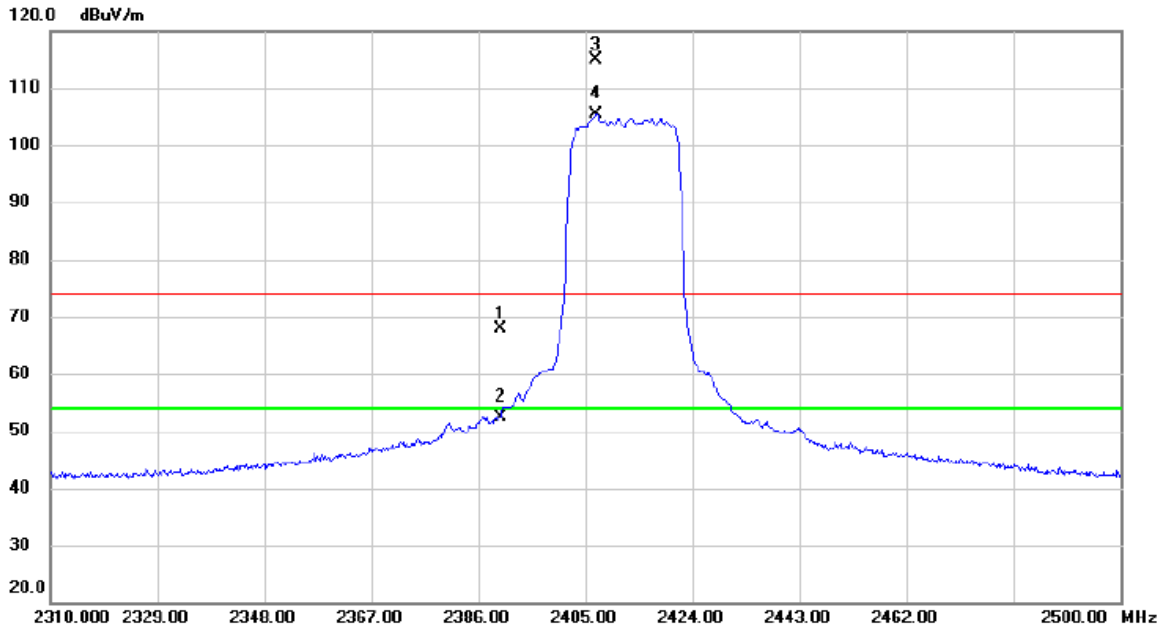

No.	Mk.	Freq. MHz	Reading Level dBuV	Correct Factor dB	Measure- ment dBuV/m	Limit dBuV/m	Margin dB	Detector	Comment
1		2390.000	36.24	31.74	67.98	74.00	-6.02	peak	
2		2390.000	20.67	31.74	52.41	54.00	-1.59	AVG	
3	X	2406.900	83.21	31.72	114.93	74.00	40.93	peak	No limit
4	*	2406.900	73.60	31.72	105.32	54.00	51.32	AVG	No limit

REMARKS:

- (1) Measurement Value = Reading Level + Correct Factor.
- (2) Margin Level = Measurement Value - Limit Value.

Test Mode: TX AX (HE20) Mode 2412 MHz

Vertical

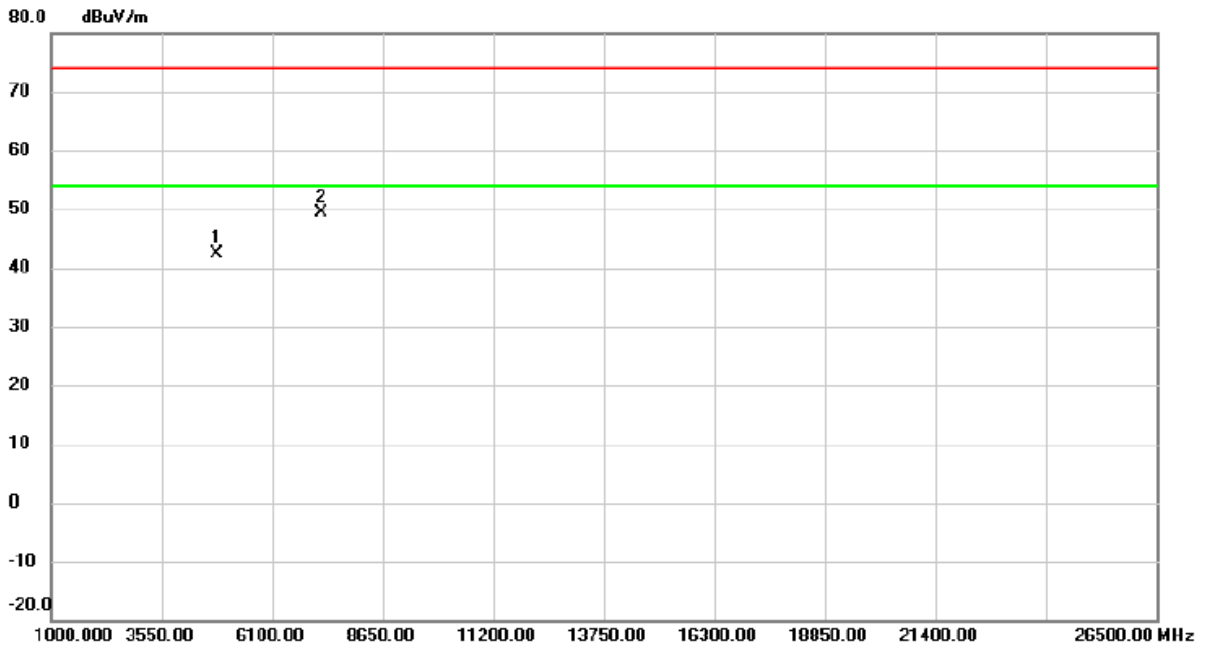

No.	Mk.	Freq. MHz	Reading Level dBuV	Correct Factor dB	Measure- ment dBuV/m	Limit dBuV/m	Margin dB	Detector	Comment
1		4827.550	58.45	-16.03	42.42	74.00	-31.58	peak	
2	*	7234.750	60.21	-10.85	49.36	74.00	-24.64	peak	

REMARKS:

- (1) Measurement Value = Reading Level + Correct Factor.
- (2) Margin Level = Measurement Value - Limit Value.

Test Mode: TX AX (HE20) Mode 2412 MHz

Horizontal

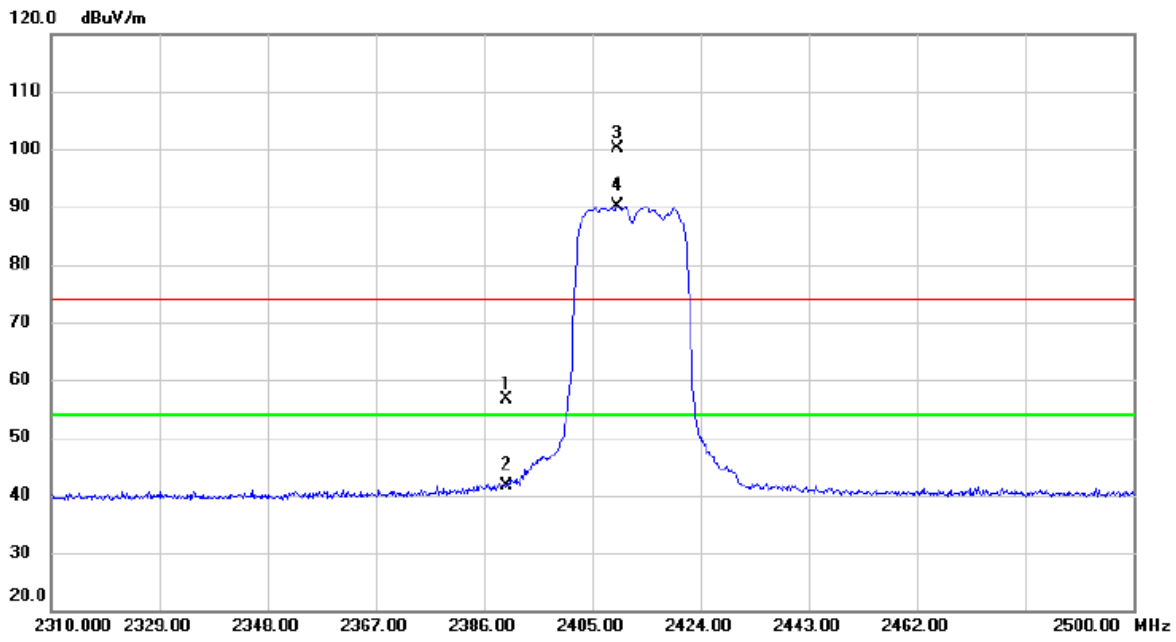

No.	Mk.	Freq. MHz	Reading Level dBuV	Correct Factor dB	Measure- ment dBuV/m	Limit dBuV/m	Margin dB	Detector	Comment
1		2390.000	24.86	31.74	56.60	74.00	-17.40	peak	
2		2390.000	9.96	31.74	41.70	54.00	-12.30	AVG	
3	X	2409.560	68.30	31.72	100.02	74.00	26.02	peak	No limit
4	*	2409.560	58.49	31.72	90.21	54.00	36.21	AVG	No limit

REMARKS:

- (1) Measurement Value = Reading Level + Correct Factor.
- (2) Margin Level = Measurement Value - Limit Value.

Test Mode: TX AX (HE20) Mode 2412 MHz

Horizontal

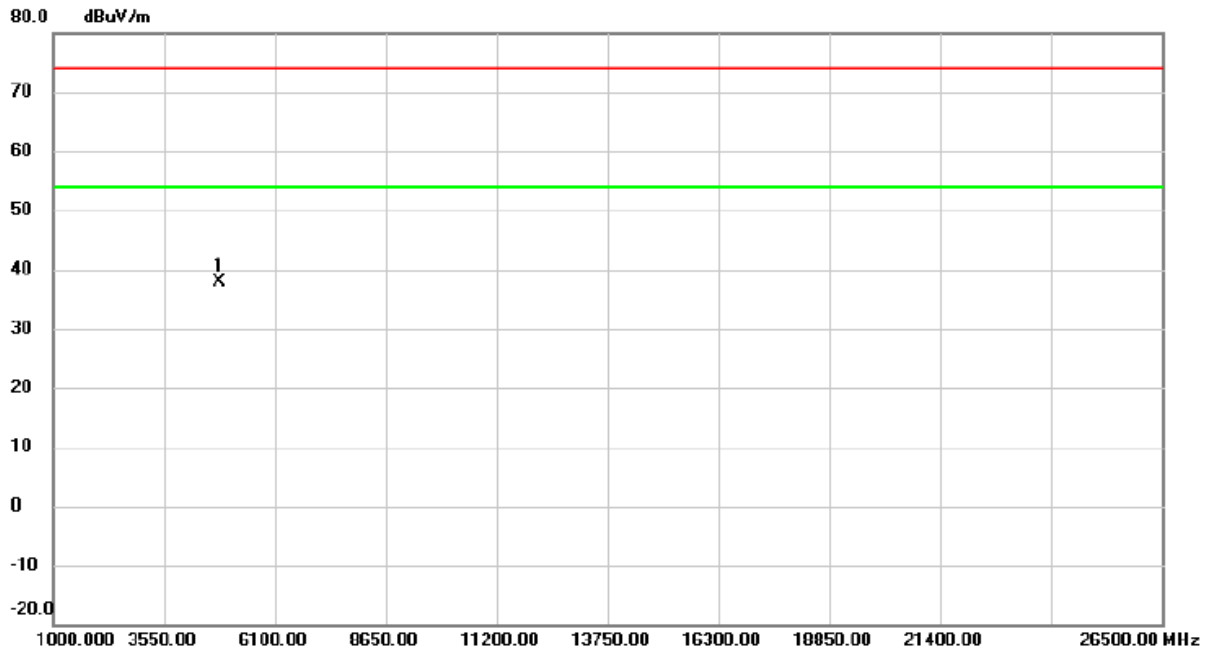

No.	Mk.	Freq.	Reading Level	Correct Factor	Measurement	Limit	Margin	Detector	Comment
		MHz	dBuV	dB	dBuV/m	dBuV/m	dB		
1	*	4824.000	53.92	-16.03	37.89	74.00	-36.11	peak	

REMARKS:

- (1) Measurement Value = Reading Level + Correct Factor.
- (2) Margin Level = Measurement Value - Limit Value.

Test Mode: TX AX (HE20) Mode 2437 MHz

Vertical

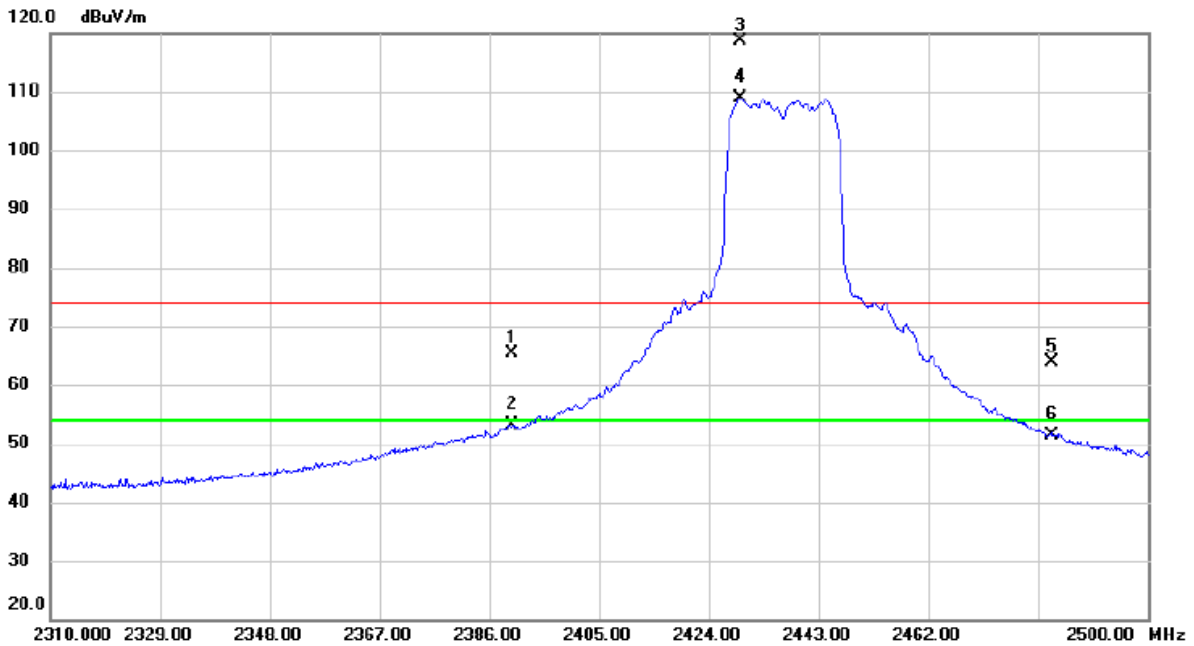

No.	Mk.	Freq. MHz	Reading Level dBuV	Correct Factor dB	Measure- ment dBuV/m	Limit dBuV/m	Margin dB	Detector	Comment
1		2390.000	33.64	31.74	65.38	74.00	-8.62	peak	
2		2390.000	21.38	31.74	53.12	54.00	-0.88	AVG	
3	X	2429.415	86.86	31.72	118.58	74.00	44.58	peak	No limit
4	*	2429.415	77.23	31.72	108.95	54.00	54.95	AVG	No limit
5		2483.500	32.17	31.72	63.89	74.00	-10.11	peak	
6		2483.500	19.73	31.72	51.45	54.00	-2.55	AVG	

REMARKS:

(1) Measurement Value = Reading Level + Correct Factor.

(2) Margin Level = Measurement Value - Limit Value.

Test Mode: TX AX (HE20) Mode 2437 MHz

Vertical

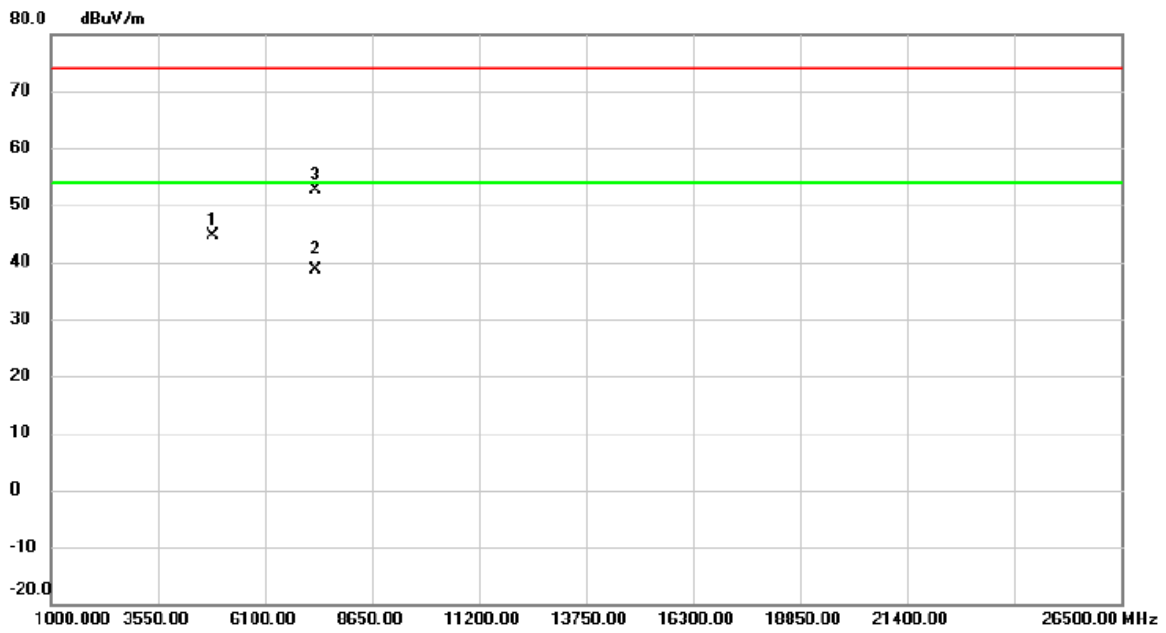

No.	Mk.	Freq. MHz	Reading Level dBuV	Correct Factor dB	Measure- ment dBuV/m	Limit dBuV/m	Margin dB	Detector	Comment
1		4868.350	60.69	-15.97	44.72	74.00	-29.28	peak	
2	*	7313.877	49.39	-10.81	38.58	54.00	-15.42	AVG	
3		7316.350	63.55	-10.81	52.74	74.00	-21.26	peak	

REMARKS:

- (1) Measurement Value = Reading Level + Correct Factor.
- (2) Margin Level = Measurement Value - Limit Value.

Test Mode: TX AX (HE20) Mode 2437 MHz

Horizontal

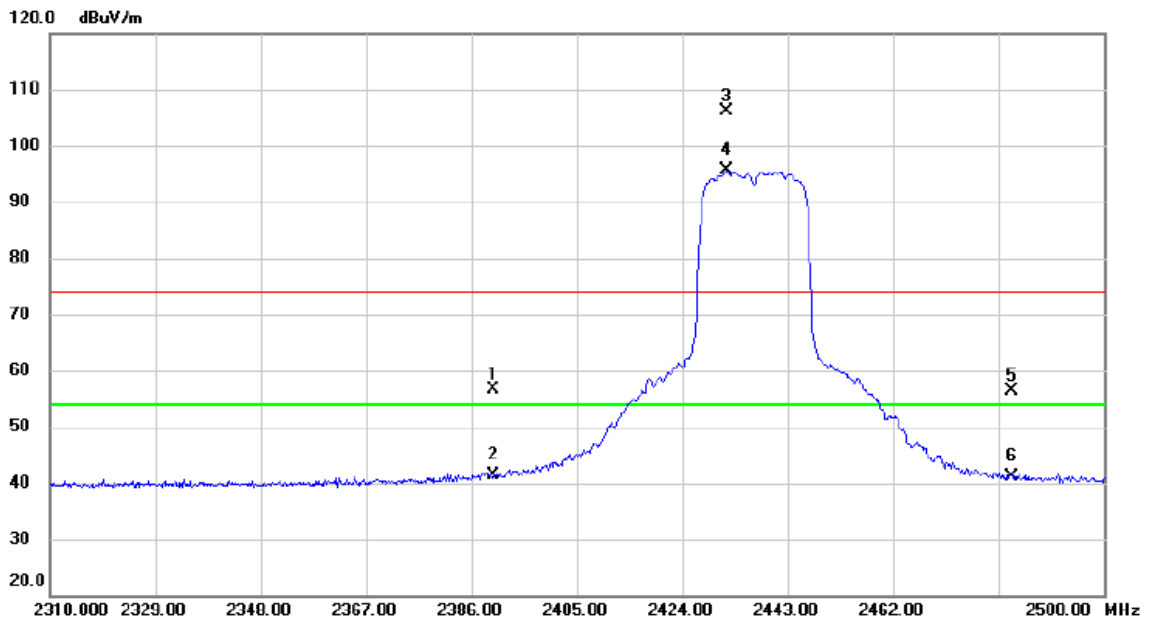

No.	Mk.	Freq. MHz	Reading Level dBuV	Correct Factor dB	Measure- ment dBuV/m	Limit dBuV/m	Margin dB	Detector	Comment
1		2390.000	24.81	31.74	56.55	74.00	-17.45	peak	
2		2390.000	9.67	31.74	41.41	54.00	-12.59	AVG	
3	X	2431.885	74.51	31.72	106.23	74.00	32.23	peak	No limit
4	*	2431.885	63.79	31.72	95.51	54.00	41.51	AVG	No limit
5		2483.500	24.73	31.72	56.45	74.00	-17.55	peak	
6		2483.500	9.47	31.72	41.19	54.00	-12.81	AVG	

REMARKS:

- (1) Measurement Value = Reading Level + Correct Factor.
- (2) Margin Level = Measurement Value - Limit Value.

Test Mode: TX AX (HE20) Mode 2437 MHz

Horizontal

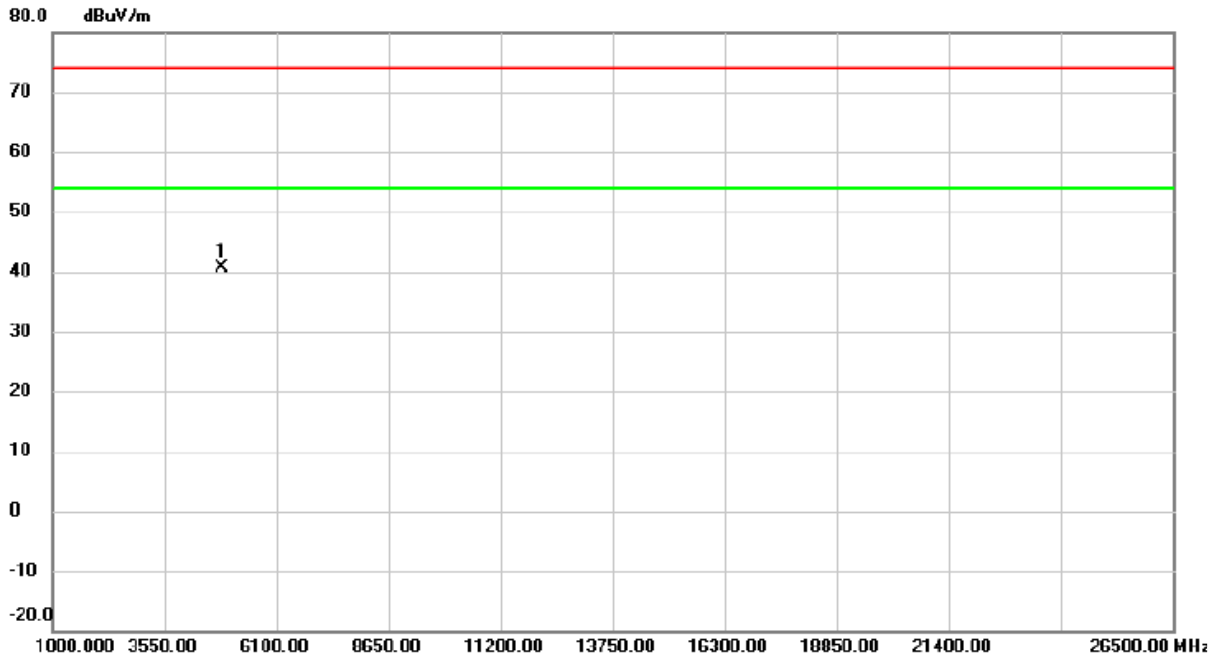

No.	Mk.	Freq. MHz	Reading Level dBuV	Correct Factor dB	Measure- ment dBuV/m	Limit dBuV/m	Margin dB	Detector	Comment
1	*	4873.450	56.63	-15.96	40.67	74.00	-33.33	peak	

REMARKS:

- (1) Measurement Value = Reading Level + Correct Factor.
- (2) Margin Level = Measurement Value - Limit Value.

Test Mode: TX AX (HE20) Mode 2462 MHz

Vertical

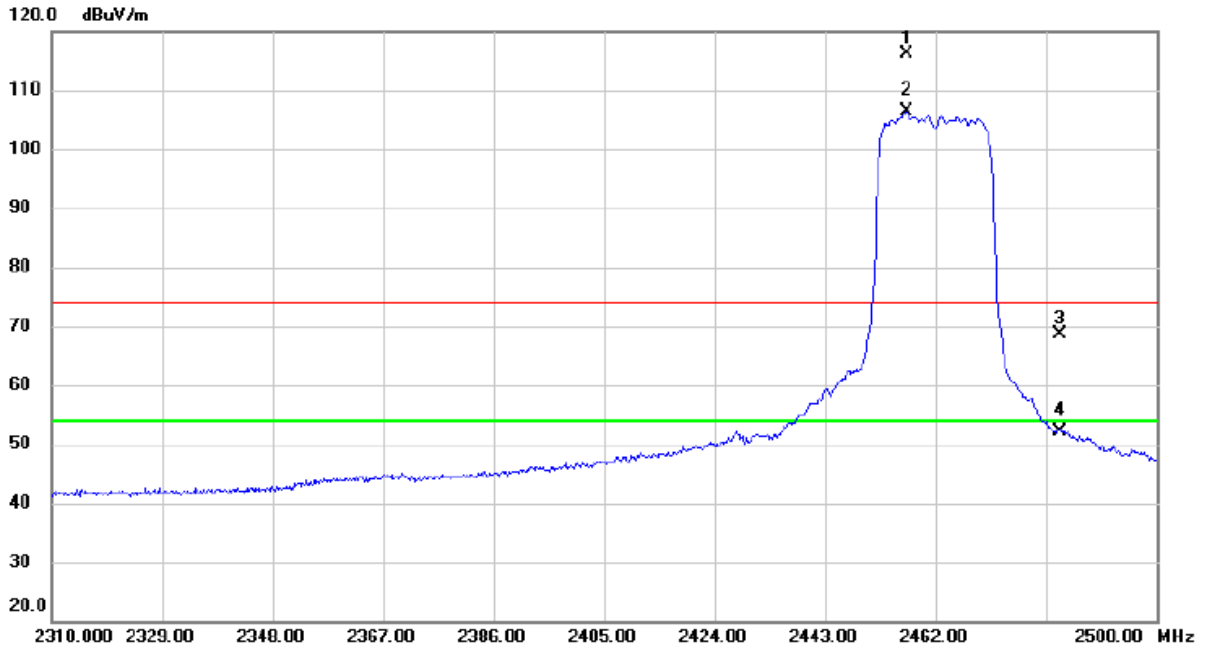

No.	Mk.	Freq. MHz	Reading Level dBuV	Correct Factor dB	Measure- ment dBuV/m	Limit dBuV/m	Margin dB	Detector	Comment
1	X	2457.060	84.54	31.71	116.25	74.00	42.25	peak	No limit
2	*	2457.060	74.60	31.71	106.31	54.00	52.31	AVG	No limit
3		2483.500	37.01	31.72	68.73	74.00	-5.27	peak	
4		2483.500	20.42	31.72	52.14	54.00	-1.86	AVG	

REMARKS:

- (1) Measurement Value = Reading Level + Correct Factor.
- (2) Margin Level = Measurement Value - Limit Value.

Test Mode: TX AX (HE20) Mode 2462 MHz

Vertical

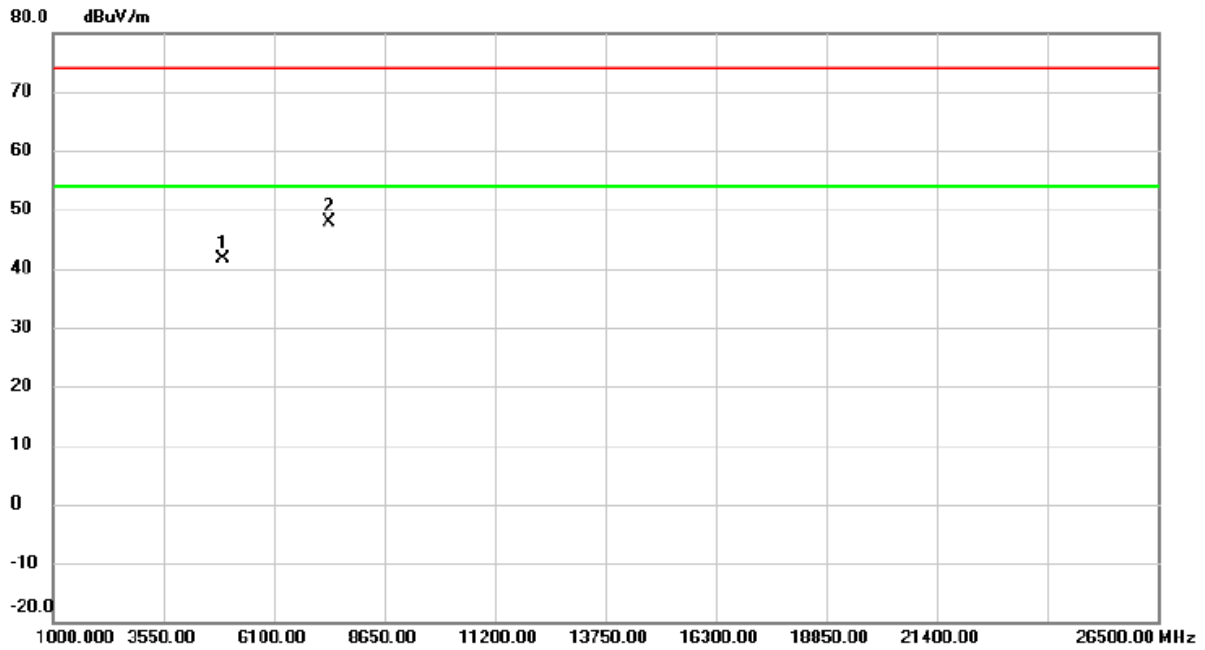

No.	Mk.	Freq. MHz	Reading Level dBuV	Correct Factor dB	Measure- ment dBuV/m	Limit dBuV/m	Margin dB	Detector	Comment
1		4919.350	57.45	-15.86	41.59	74.00	-32.41	peak	
2	*	7385.200	58.65	-10.79	47.86	74.00	-26.14	peak	

REMARKS:

- (1) Measurement Value = Reading Level + Correct Factor.
- (2) Margin Level = Measurement Value - Limit Value.

Test Mode: TX AX (HE20) Mode 2462 MHz

Horizontal

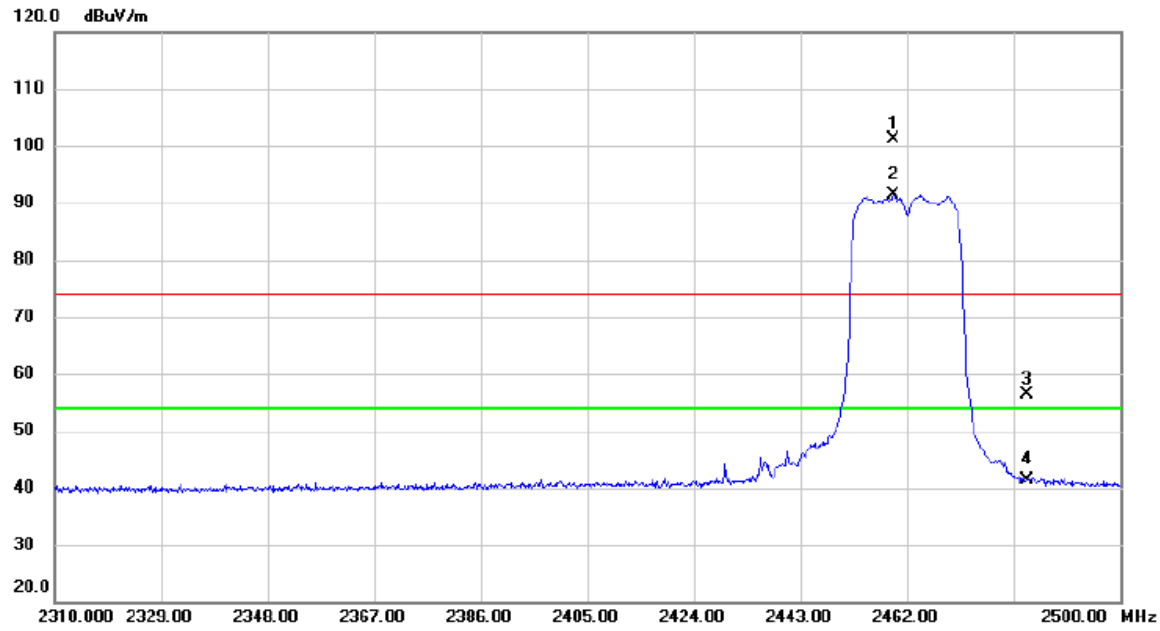

No.	Mk.	Freq. MHz	Reading Level dBuV	Correct Factor dB	Measure- ment dBuV/m	Limit dBuV/m	Margin dB	Detector	Comment
1	X	2459.625	69.44	31.71	101.15	74.00	27.15	peak	No limit
2	*	2459.625	59.65	31.71	91.36	54.00	37.36	AVG	No limit
3		2483.500	24.58	31.72	56.30	74.00	-17.70	peak	
4		2483.500	9.77	31.72	41.49	54.00	-12.51	AVG	

REMARKS:

- (1) Measurement Value = Reading Level + Correct Factor.
- (2) Margin Level = Measurement Value - Limit Value.

Test Mode: TX AX (HE20) Mode 2462 MHz

Horizontal

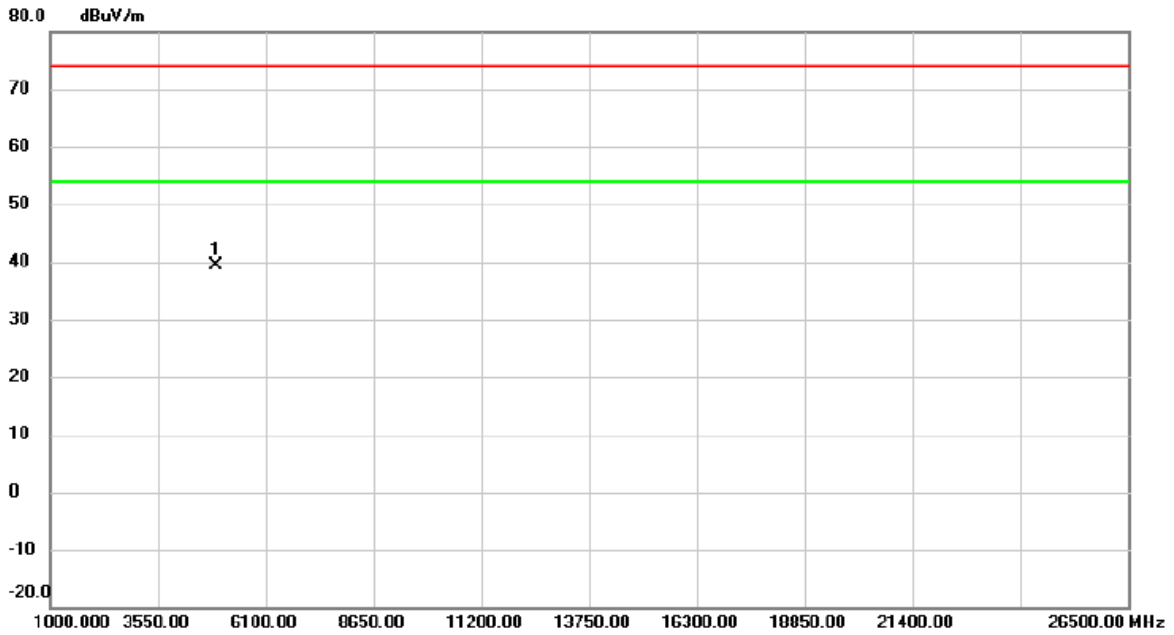

No.	Mk.	Freq. MHz	Reading Level dBuV	Correct Factor dB	Measure- ment dBuV/m	Limit dBuV/m	Margin dB	Detector	Comment
1	*	4934.650	55.27	-15.79	39.48	74.00	-34.52	peak	

REMARKS:

- (1) Measurement Value = Reading Level + Correct Factor.
- (2) Margin Level = Measurement Value - Limit Value.

Test Mode: TX AX (HE40) Mode 2422 MHz

Vertical

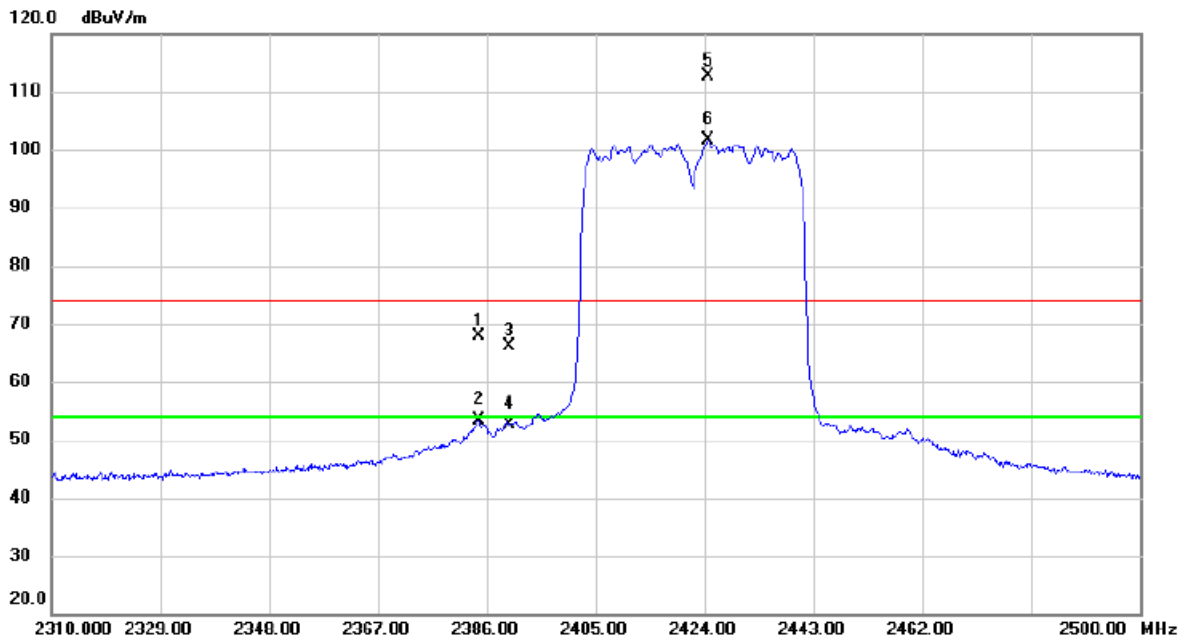

No. Mk.	Freq. MHz	Reading Level dBuV	Correct Factor dB	Measurement dBuV/m	Limit dBuV/m	Margin dB	Detector	Comment
1	2384.480	36.03	31.75	67.78	74.00	-6.22	peak	
2	2384.480	21.57	31.75	53.32	54.00	-0.68	AVG	
3	2390.000	34.43	31.74	66.17	74.00	-7.83	peak	
4	2390.000	20.83	31.74	52.57	54.00	-1.43	AVG	
5 X	2424.570	80.95	31.72	112.67	74.00	38.67	peak	No limit
6 *	2424.570	69.87	31.72	101.59	54.00	47.59	AVG	No limit

REMARKS:

- (1) Measurement Value = Reading Level + Correct Factor.
- (2) Margin Level = Measurement Value - Limit Value.

Test Mode: TX AX (HE40) Mode 2422 MHz

Vertical

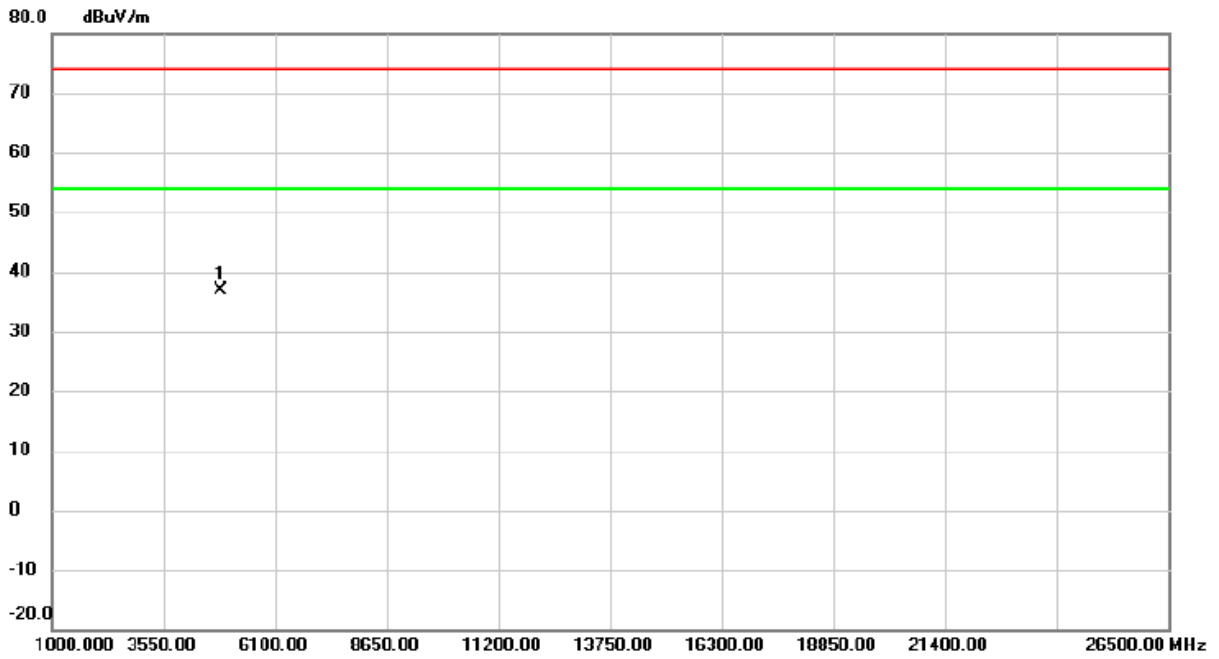

No.	Mk.	Freq. MHz	Reading Level dBuV	Correct Factor dB	Measure- ment dBuV/m	Limit dBuV/m	Margin dB	Detector	Comment
1	*	4844.000	52.86	-16.01	36.85	74.00	-37.15	peak	

REMARKS:

- (1) Measurement Value = Reading Level + Correct Factor.
- (2) Margin Level = Measurement Value - Limit Value.

Test Mode: TX AX (HE40) Mode 2422 MHz

Horizontal

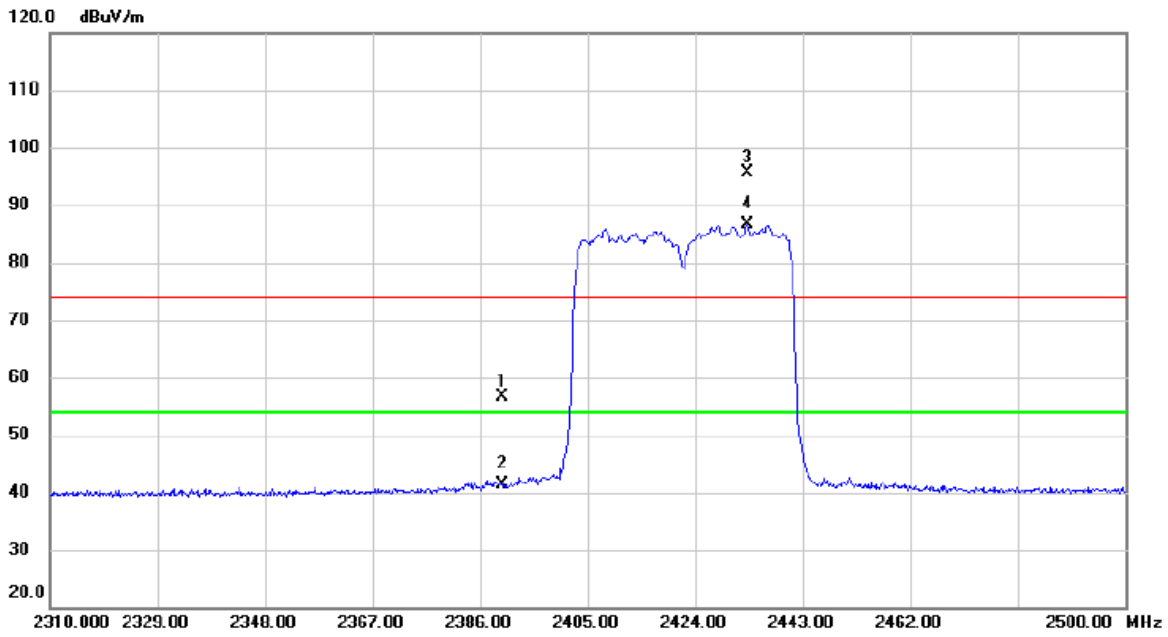

No.	Mk.	Freq. MHz	Reading Level dBuV	Correct Factor dB	Measure- ment dBuV/m	Limit dBuV/m	Margin dB	Detector	Comment
1		2390.000	24.77	31.74	56.51	74.00	-17.49	peak	
2		2390.000	9.71	31.74	41.45	54.00	-12.55	AVG	
3	X	2433.215	63.87	31.72	95.59	74.00	21.59	peak	No limit
4	*	2433.215	54.88	31.72	86.60	54.00	32.60	AVG	No limit

REMARKS:

- (1) Measurement Value = Reading Level + Correct Factor.
- (2) Margin Level = Measurement Value - Limit Value.

Test Mode: TX AX (HE40) Mode 2422 MHz

Horizontal

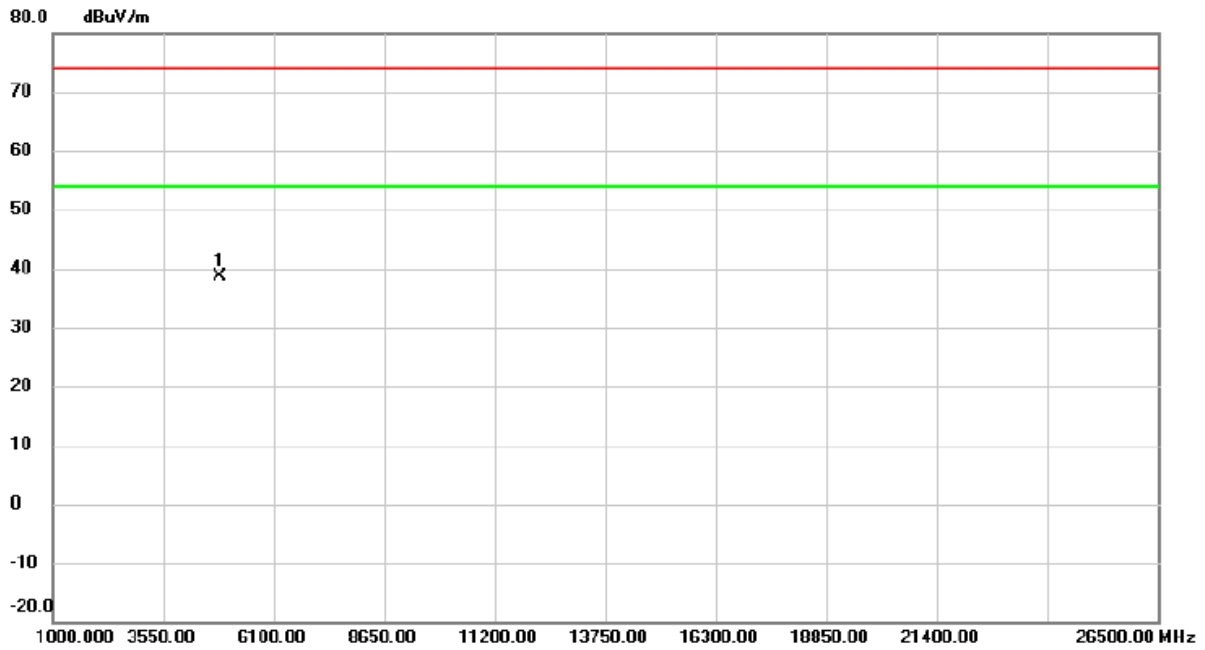

No.	Mk.	Freq. MHz	Reading Level dBuV	Correct Factor dB	Measure- ment dBuV/m	Limit dBuV/m	Margin dB	Detector	Comment
1	*	4844.000	49.37	-10.86	38.51	74.00	-35.49	peak	

REMARKS:

- (1) Measurement Value = Reading Level + Correct Factor.
- (2) Margin Level = Measurement Value - Limit Value.

Test Mode: TX AX (HE40) Mode 2437 MHz

Vertical

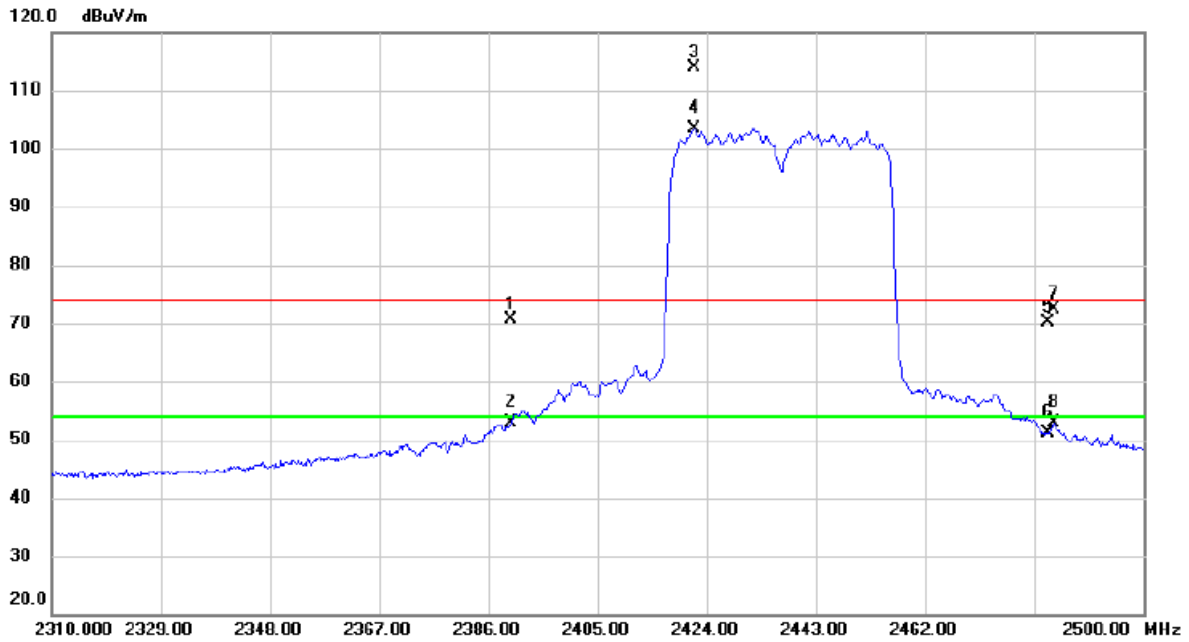

No.	Mk.	Freq. MHz	Reading Level dBuV	Correct Factor dB	Measure- ment dBuV/m	Limit dBuV/m	Margin dB	Detector	Comment
1		2390.000	38.85	31.74	70.59	74.00	-3.41	peak	
2		2390.000	21.23	31.74	52.97	54.00	-1.03	AVG	
3	X	2421.815	82.18	31.72	113.90	74.00	39.90	peak	No limit
4	*	2421.815	71.68	31.72	103.40	54.00	49.40	AVG	No limit
5		2483.500	38.37	31.72	70.09	74.00	-3.91	peak	
6		2483.500	19.30	31.72	51.02	54.00	-2.98	AVG	
7		2484.325	40.62	31.72	72.34	74.00	-1.66	peak	
8		2484.325	21.11	31.72	52.83	54.00	-1.17	AVG	

REMARKS:

- (1) Measurement Value = Reading Level + Correct Factor.
- (2) Margin Level = Measurement Value - Limit Value.

Test Mode: TX AX (HE40) Mode 2437 MHz

Vertical

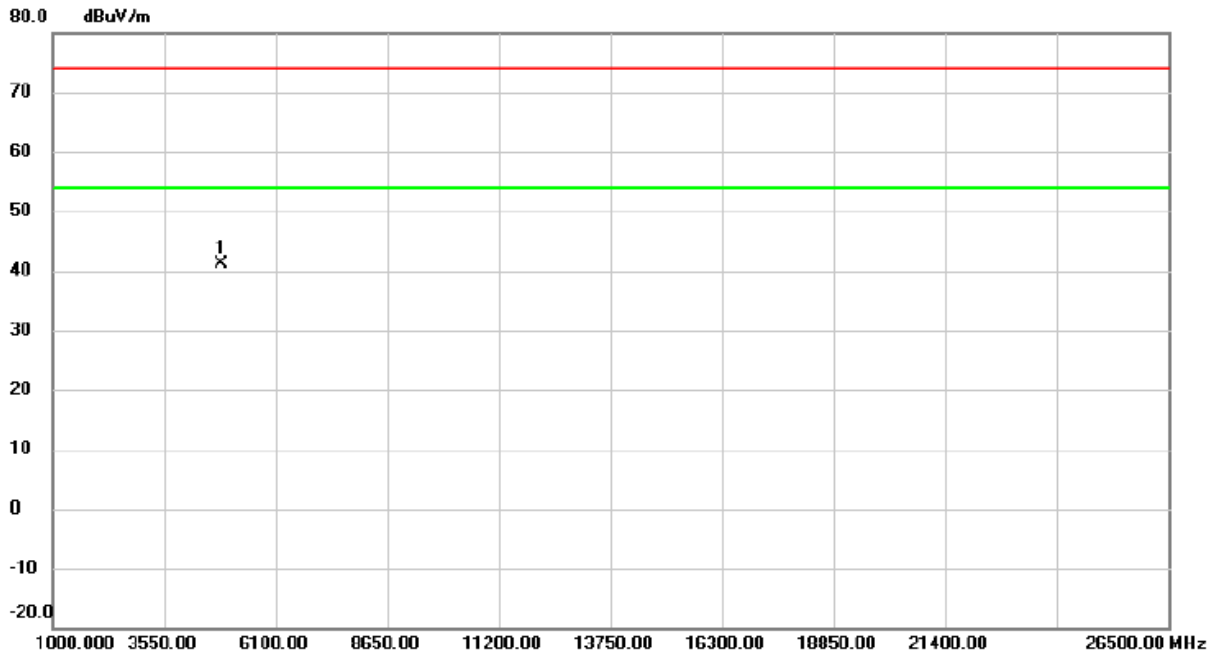

No.	Mk.	Freq. MHz	Reading Level dBuV	Correct Factor dB	Measure- ment dBuV/m	Limit dBuV/m	Margin dB	Detector	Comment
1	*	4873.450	51.89	-10.79	41.10	74.00	-32.90	peak	

REMARKS:

- (1) Measurement Value = Reading Level + Correct Factor.
- (2) Margin Level = Measurement Value - Limit Value.

Test Mode: TX AX (HE40) Mode 2437 MHz

Horizontal

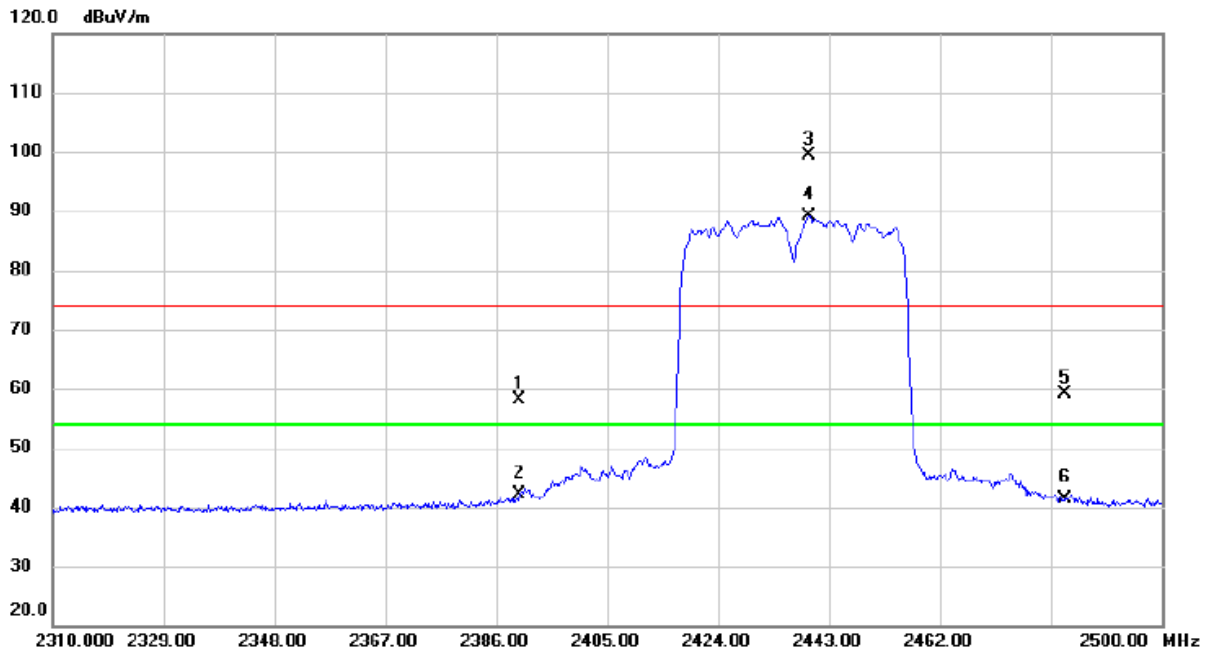

No.	Mk.	Freq. MHz	Reading Level dBuV	Correct Factor dB	Measure- ment dBuV/m	Limit dBuV/m	Margin dB	Detector	Comment
1		2390.000	26.35	31.74	58.09	74.00	-15.91	peak	
2		2390.000	10.51	31.74	42.25	54.00	-11.75	AVG	
3	X	2439.580	67.54	31.72	99.26	74.00	25.26	peak	No limit
4	*	2439.580	57.43	31.72	89.15	54.00	35.15	AVG	No limit
5		2483.500	27.35	31.72	59.07	74.00	-14.93	peak	
6		2483.500	9.64	31.72	41.36	54.00	-12.64	AVG	

REMARKS:

- (1) Measurement Value = Reading Level + Correct Factor.
- (2) Margin Level = Measurement Value - Limit Value.

Test Mode: TX AX (HE40) Mode 2437 MHz

Horizontal

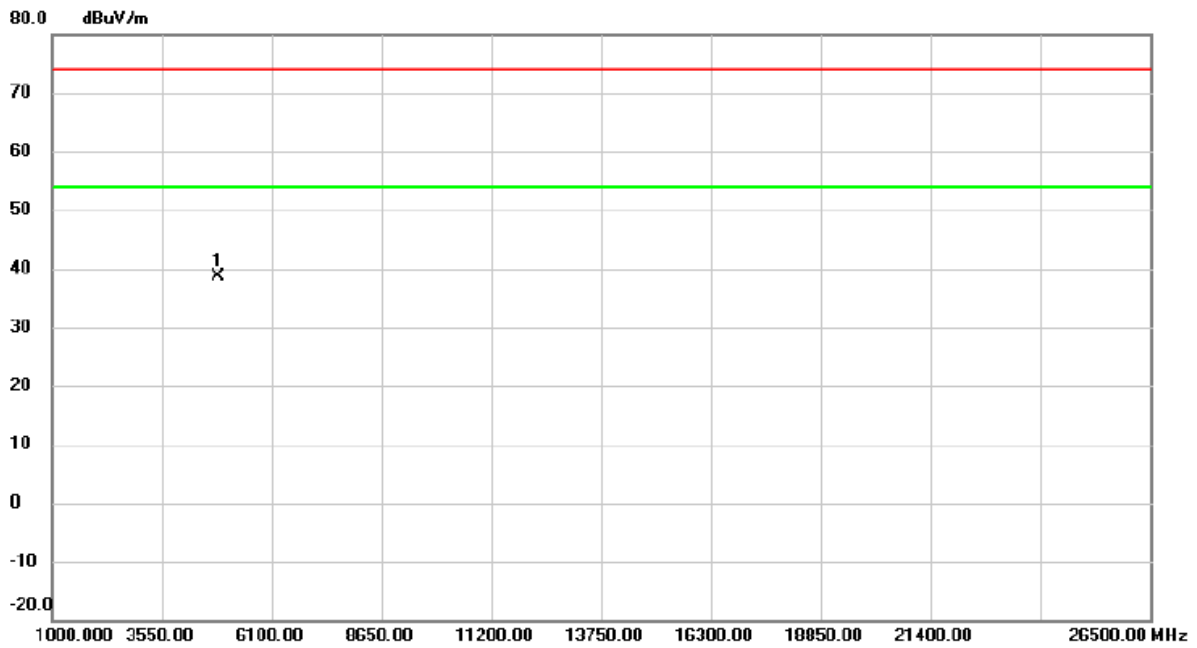

No.	Mk.	Freq.	Reading Level	Correct Factor	Measurement	Limit	Margin	Detector	Comment
		MHz	dBuV	dB	dBuV/m	dBuV/m	dB		
1	*	4874.000	49.43	-10.79	38.64	74.00	-35.36	peak	

REMARKS:

- (1) Measurement Value = Reading Level + Correct Factor.
- (2) Margin Level = Measurement Value - Limit Value.

Test Mode: TX AX (HE40) Mode 2452 MHz

Vertical

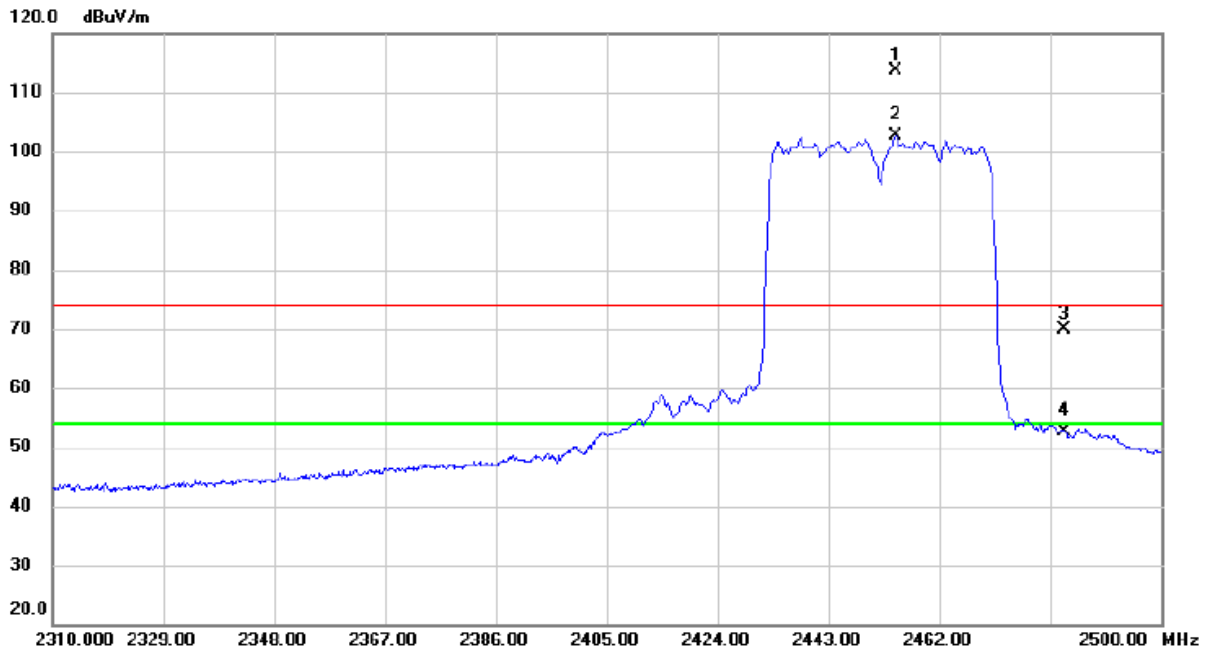

No.	Mk.	Freq. MHz	Reading Level dBuV	Correct Factor dB	Measure- ment dBuV/m	Limit dBuV/m	Margin dB	Detector	Comment
1	X	2454.590	81.96	31.72	113.68	74.00	39.68	peak	No limit
2	*	2454.590	70.80	31.72	102.52	54.00	48.52	AVG	No limit
3		2483.500	38.13	31.72	69.85	74.00	-4.15	peak	
4		2483.500	20.85	31.72	52.57	54.00	-1.43	AVG	

REMARKS:

- (1) Measurement Value = Reading Level + Correct Factor.
- (2) Margin Level = Measurement Value - Limit Value.

Test Mode: TX AX (HE40) Mode 2452 MHz

Vertical

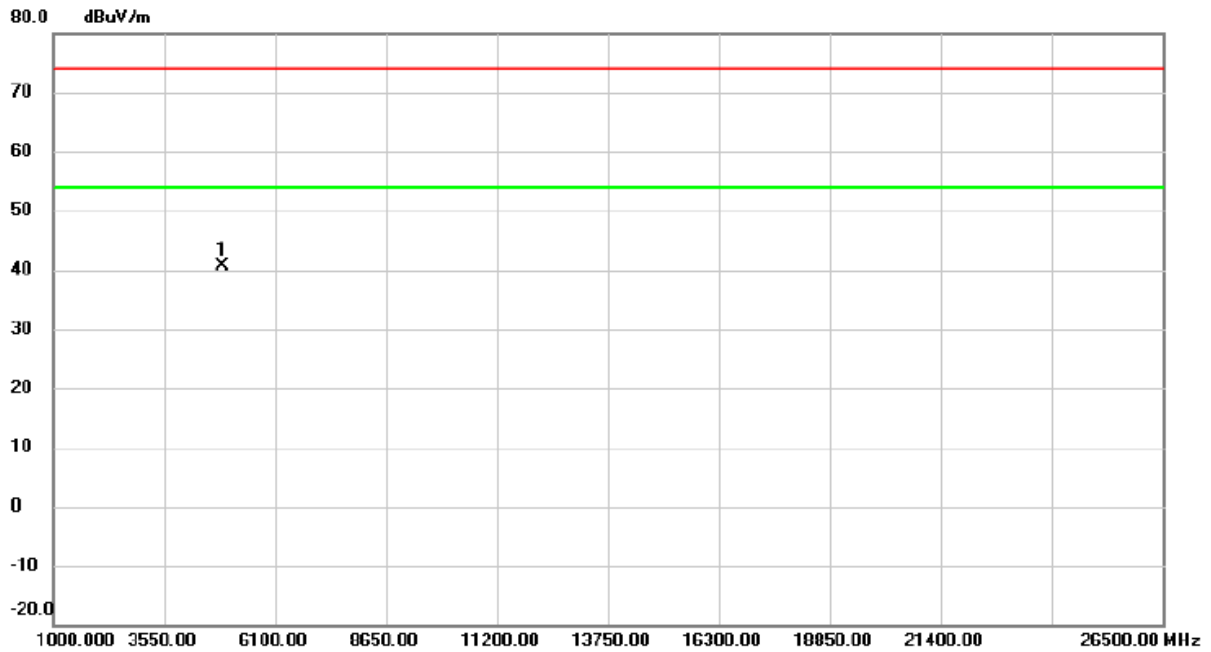

No.	Mk.	Freq. MHz	Reading Level dBuV	Correct Factor dB	Measure- ment dBuV/m	Limit dBuV/m	Margin dB	Detector	Comment
1	*	4896.400	51.25	-10.74	40.51	74.00	-33.49	peak	

REMARKS:

- (1) Measurement Value = Reading Level + Correct Factor.
- (2) Margin Level = Measurement Value - Limit Value.

Test Mode: TX AX (HE40) Mode 2452 MHz

Horizontal

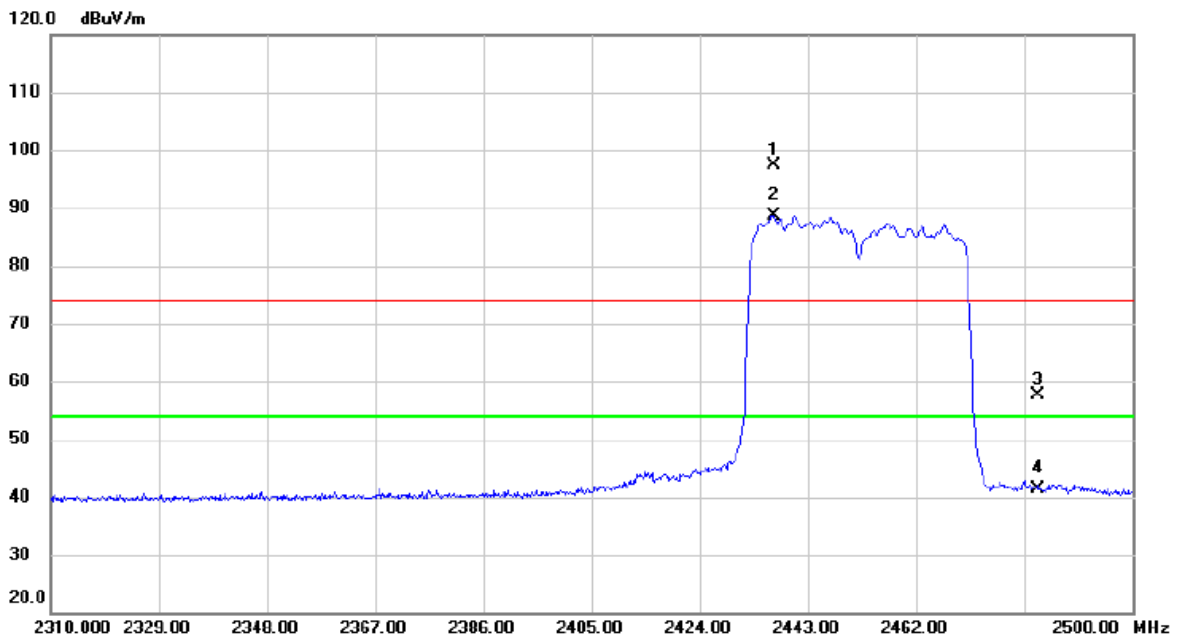

No.	Mk.	Freq. MHz	Reading Level dBuV	Correct Factor dB	Measure- ment dBuV/m	Limit dBuV/m	Margin dB	Detector	Comment
1	X	2437.015	65.72	31.71	97.43	74.00	23.43	peak	No limit
2	*	2437.015	56.93	31.71	88.64	54.00	34.64	AVG	No limit
3		2483.500	25.92	31.72	57.64	74.00	-16.36	peak	
4		2483.500	9.77	31.72	41.49	54.00	-12.51	AVG	

REMARKS:

- (1) Measurement Value = Reading Level + Correct Factor.
- (2) Margin Level = Measurement Value - Limit Value.

Test Mode: TX AX (HE40) Mode 2452 MHz

Horizontal

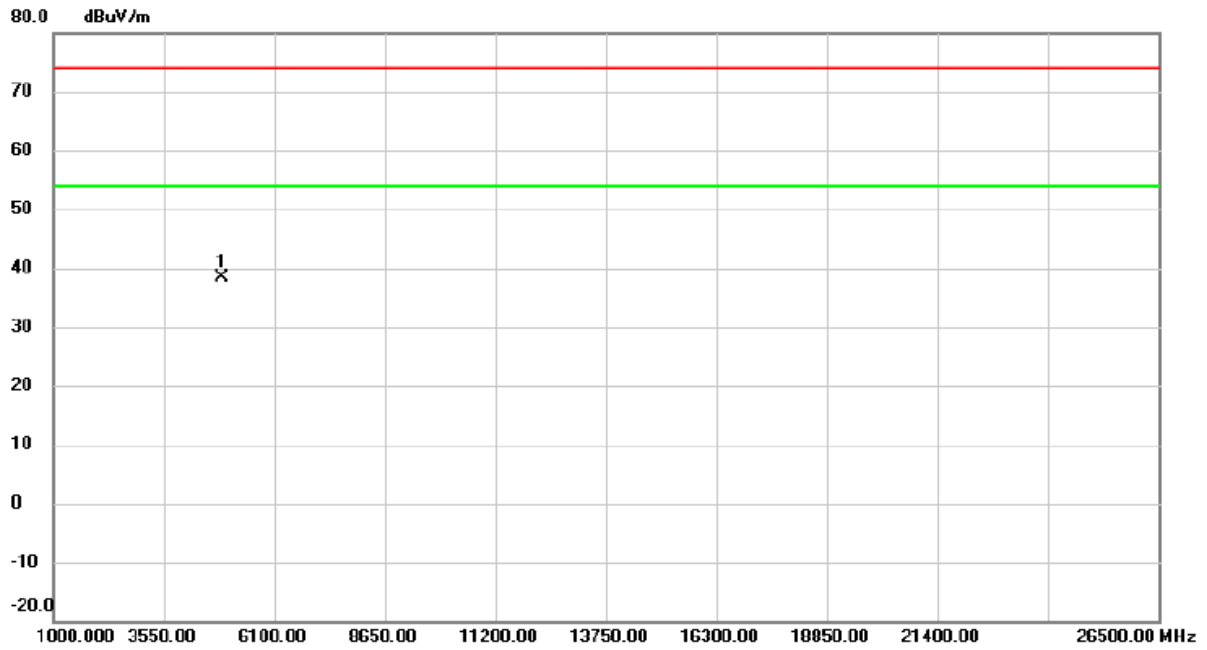

No.	Mk.	Freq. MHz	Reading Level dBuV	Correct Factor dB	Measure- ment dBuV/m	Limit dBuV/m	Margin dB	Detector	Comment
1	*	4904.000	49.04	-10.72	38.32	74.00	-35.68	peak	

REMARKS:

- (1) Measurement Value = Reading Level + Correct Factor.
- (2) Margin Level = Measurement Value - Limit Value.

APPENDIX E - BANDWIDTH

CDD

Test Mode	TX AX (HE20) Mode
-----------	-------------------

Channel	Frequency (MHz)	6 dB Bandwidth (MHz)	6 dB Bandwidth Min. Limit (kHz)	Result
01	2412	18.44	500	Complies
06	2437	18.27	500	Complies
11	2462	18.27	500	Complies

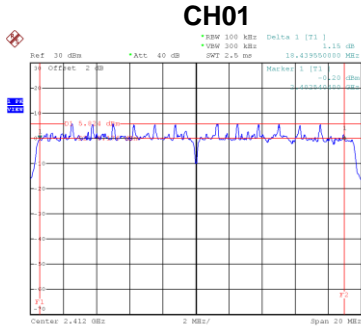

Date: 23_JUL_2020 11:04:20

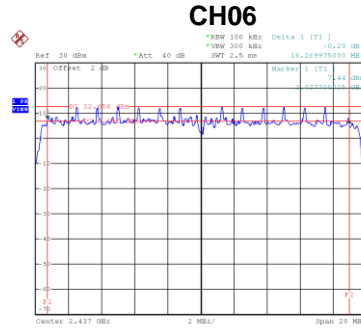

Date: 23_JUL_2020 11:05:24

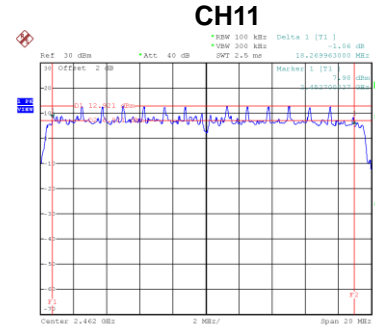

Date: 23_JUL_2020 11:08:26

Channel	Frequency (MHz)	99 % Emission Bandwidth (MHz)
01	2412	19.28
06	2437	19.44
11	2462	19.44

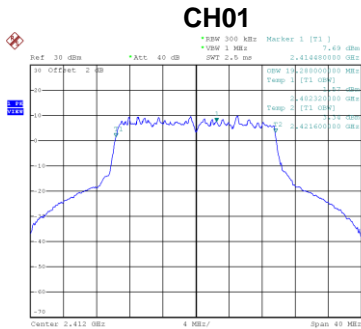

Date: 23_JUL_2020 11:04:26

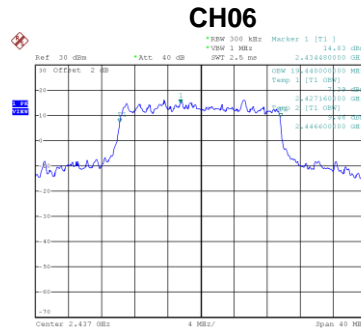

Date: 23_JUL_2020 11:05:31

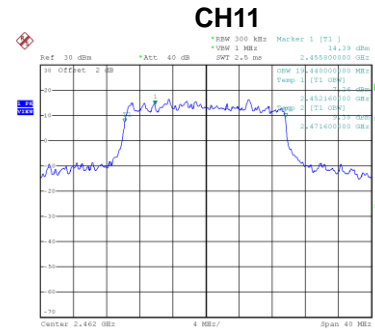

Date: 23_JUL_2020 11:08:33

Test Mode TX AX (HE40) Mode

Channel	Frequency (MHz)	6 dB Bandwidth (MHz)	6 dB Bandwidth Min. Limit (kHz)	Result
03	2422	36.08	500	Complies
06	2437	36.64	500	Complies
09	2452	36.09	500	Complies

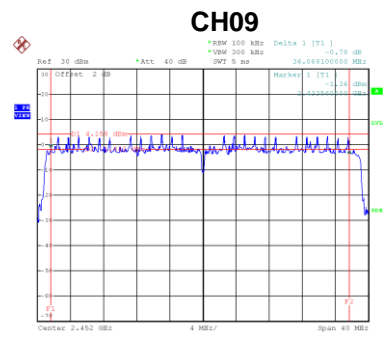
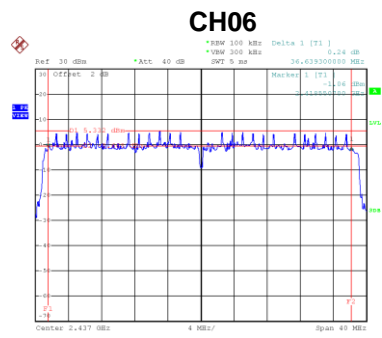
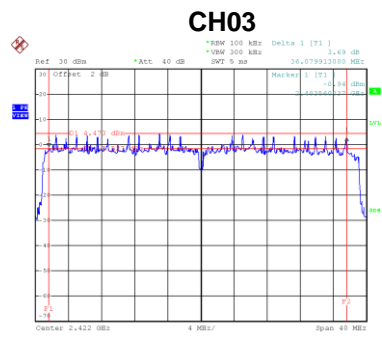

Channel	Frequency (MHz)	99 % Emission Bandwidth (MHz)
03	2422	37.92
06	2437	38.08
09	2452	37.92

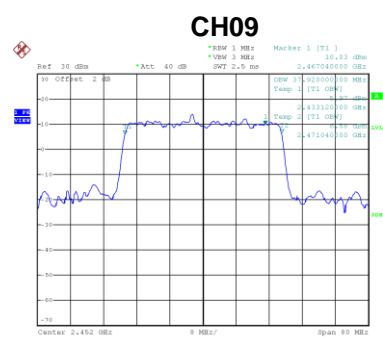
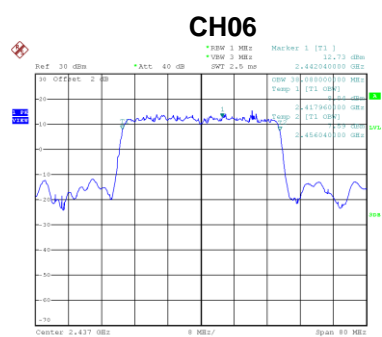
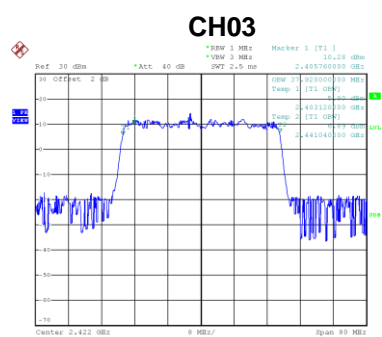

APPENDIX F - MAXIMUM OUTPUT POWER

CDD

Test Mode	TX AX (HE20) Mode_Ant. 1
-----------	--------------------------

Channel	Frequency (MHz)	Avg Output Power (dBm)	Duty Factor	Output Power + Duty Factor (dBm)	Max. Limit (dBm)	Max. Limit (W)	Result
01	2412	16.22	0.91	17.13	30.00	1.0000	Complies
06	2437	20.55	0.91	21.46	30.00	1.0000	Complies
11	2462	16.02	0.91	16.93	30.00	1.0000	Complies

Test Mode	TX AX (HE20) Mode_Ant. 2
-----------	--------------------------

Channel	Frequency (MHz)	Avg Output Power (dBm)	Duty Factor	Output Power + Duty Factor (dBm)	Max. Limit (dBm)	Max. Limit (W)	Result
01	2412	15.98	0.91	16.89	30.00	1.0000	Complies
06	2437	20.01	0.91	20.92	30.00	1.0000	Complies
11	2462	15.80	0.91	16.71	30.00	1.0000	Complies

Test Mode	TX AX (HE20) Mode_Total
-----------	-------------------------

Channel	Frequency (MHz)	Avg Output Power (dBm)	Max. Limit (dBm)	Max. Limit (W)	Result
01	2412	20.02	30.00	1.0000	Complies
06	2437	24.21	30.00	1.0000	Complies
11	2462	19.83	30.00	1.0000	Complies

Test Mode	TX AX (HE40) Mode_Ant. 1
-----------	--------------------------

Channel	Frequency (MHz)	Avg Output Power (dBm)	Duty Factor	Output Power + Duty Factor (dBm)	Max. Limit (dBm)	Max. Limit (W)	Result
01	2412	14.22	1.15	15.37	30.00	1.0000	Complies
06	2437	16.23	1.15	17.38	30.00	1.0000	Complies
11	2462	15.21	1.15	16.36	30.00	1.0000	Complies

Test Mode	TX AX (HE40) Mode_Ant. 2
-----------	--------------------------

Channel	Frequency (MHz)	Avg Output Power (dBm)	Duty Factor	Output Power + Duty Factor (dBm)	Max. Limit (dBm)	Max. Limit (W)	Result
01	2412	14.05	1.15	15.20	30.00	1.0000	Complies
06	2437	15.88	1.15	17.03	30.00	1.0000	Complies
11	2462	14.74	1.15	15.89	30.00	1.0000	Complies

Test Mode	TX AX (HE40) Mode_Total
-----------	-------------------------

Channel	Frequency (MHz)	Avg Output Power (dBm)	Max. Limit (dBm)	Max. Limit (W)	Result
01	2412	18.30	30.00	1.0000	Complies
06	2437	20.22	30.00	1.0000	Complies
11	2462	19.15	30.00	1.0000	Complies

Beamforming

Test Mode	TX AX (HE20) Mode_Ant. 1
------------------	--------------------------

Channel	Frequency (MHz)	Avg Output Power (dBm)	Duty Factor	Output Power + Duty Factor (dBm)	Max. Limit (dBm)	Max. Limit (W)	Result
01	2412	16.02	0.91	16.93	27.99	0.6295	Complies
06	2437	20.47	0.91	21.38	27.99	0.6295	Complies
11	2462	15.96	0.91	16.87	27.99	0.6295	Complies

Test Mode	TX AX (HE20) Mode_Ant. 2
------------------	--------------------------

Channel	Frequency (MHz)	Avg Output Power (dBm)	Duty Factor	Output Power + Duty Factor (dBm)	Max. Limit (dBm)	Max. Limit (W)	Result
01	2412	15.84	0.91	16.75	27.99	0.6295	Complies
06	2437	19.95	0.91	20.86	27.99	0.6295	Complies
11	2462	15.63	0.91	16.54	27.99	0.6295	Complies

Test Mode	TX AX (HE20) Mode_Total
------------------	-------------------------

Channel	Frequency (MHz)	Avg Output Power (dBm)	Max. Limit (dBm)	Max. Limit (W)	Result
01	2412	19.85	27.99	0.6295	Complies
06	2437	24.14	27.99	0.6295	Complies
11	2462	19.72	27.99	0.6295	Complies

Test Mode	TX AX (HE40) Mode_Ant. 1
-----------	--------------------------

Channel	Frequency (MHz)	Avg Output Power (dBm)	Duty Factor	Output Power + Duty Factor (dBm)	Max. Limit (dBm)	Max. Limit (W)	Result
01	2412	14.19	1.15	15.34	27.99	0.6295	Complies
06	2437	16.18	1.15	17.33	27.99	0.6295	Complies
11	2462	15.17	1.15	16.32	27.99	0.6295	Complies

Test Mode	TX AX (HE40) Mode_Ant. 2
-----------	--------------------------

Channel	Frequency (MHz)	Avg Output Power (dBm)	Duty Factor	Output Power + Duty Factor (dBm)	Max. Limit (dBm)	Max. Limit (W)	Result
01	2412	14.02	1.15	15.17	27.99	0.6295	Complies
06	2437	15.82	1.15	16.97	27.99	0.6295	Complies
11	2462	14.69	1.15	15.84	27.99	0.6295	Complies

Test Mode	TX AX (HE40) Mode_Total
-----------	-------------------------

Channel	Frequency (MHz)	Avg Output Power (dBm)	Max. Limit (dBm)	Max. Limit (W)	Result
01	2412	18.27	27.99	0.6295	Complies
06	2437	20.17	27.99	0.6295	Complies
11	2462	19.10	27.99	0.6295	Complies

APPENDIX G - CONDUCTED SPURIOUS EMISSIONS

CDD

Test Mode TX AX (HE20) Mode_Ant. 1

Bandedge-CH01

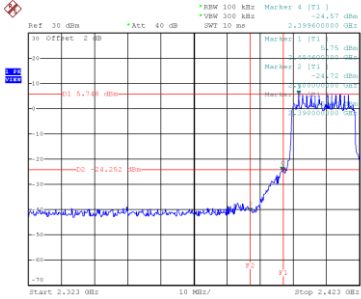

Date: 23_JUL_2020 11:04:07

Bandedge-CH11

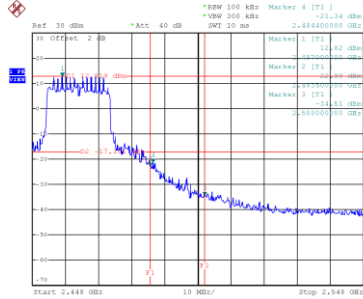

Date: 23_JUL_2020 11:38:14

CH01 – 10th Harmonic of the fundamental frequency

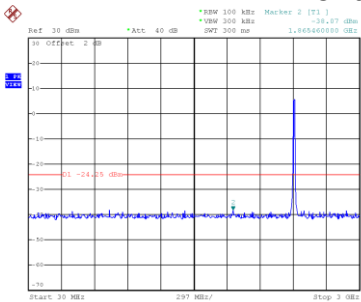

Date: 23_JUL_2020 11:04:39

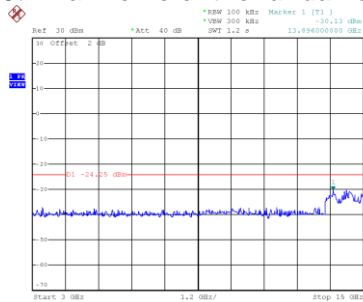

Date: 23_JUL_2020 11:04:47

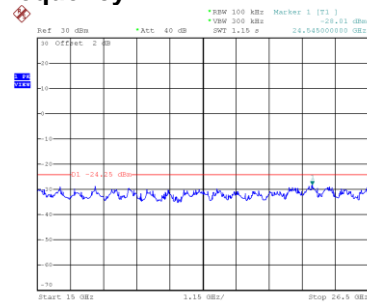

Date: 23_JUL_2020 11:04:54

CH06 – 10th Harmonic of the fundamental frequency

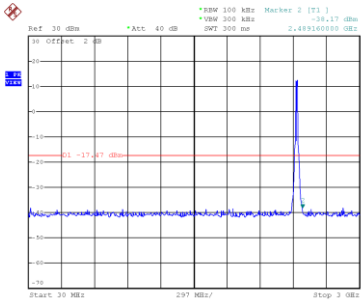

Date: 23_JUL_2020 11:35:44

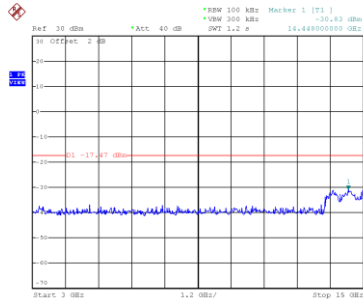

Date: 23_JUL_2020 11:35:51

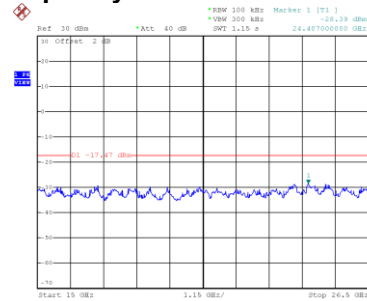

Date: 23_JUL_2020 11:35:57

CH11 – 10th Harmonic of the fundamental frequency

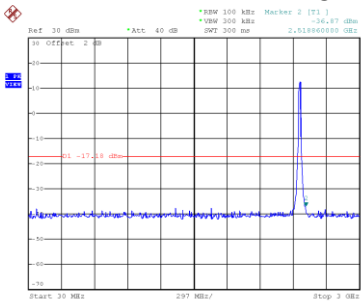

Date: 23_JUL_2020 11:38:46

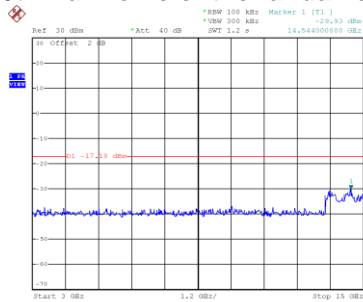

Date: 23_JUL_2020 11:38:53

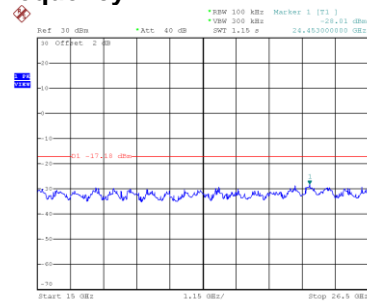

Date: 23_JUL_2020 11:39:00

Test Mode

TX AX (HE20) Mode_Ant. 2

Bandedge-CH01

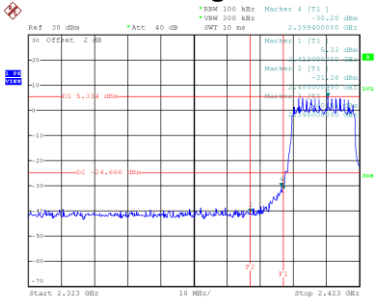

Date: 23_JUL_2020 11:06:17

Bandedge-CH11

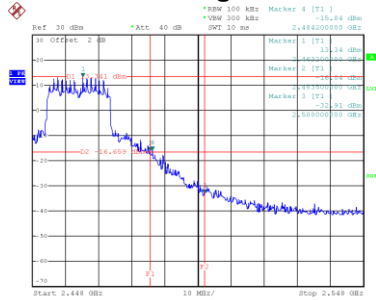

Date: 23_JUL_2020 11:40:15

CH01 – 10th Harmonic of the fundamental frequency

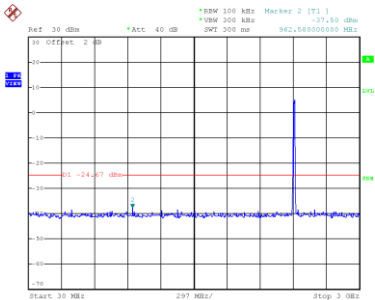

Date: 23_JUL_2020 11:06:15

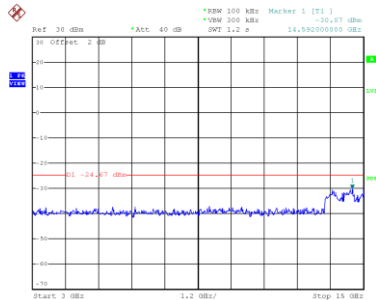

Date: 23_JUL_2020 11:06:58

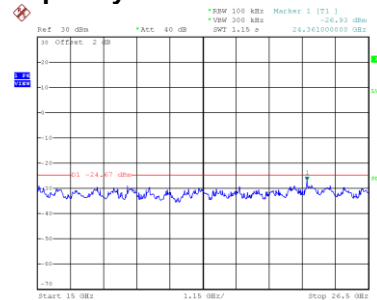

Date: 23_JUL_2020 11:07:05

CH06 – 10th Harmonic of the fundamental frequency

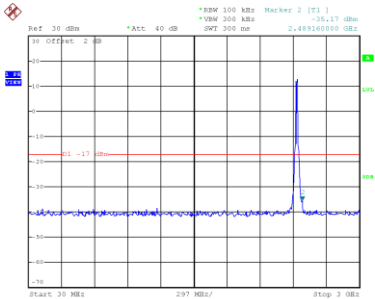

Date: 23_JUL_2020 11:34:02

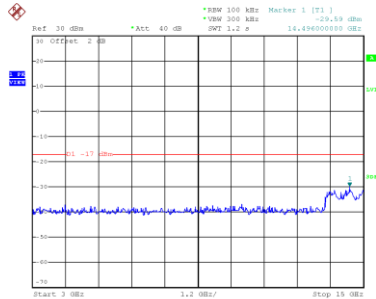

Date: 23_JUL_2020 11:34:09

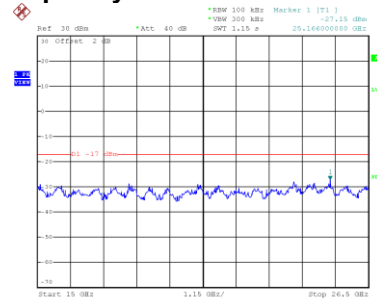

Date: 23_JUL_2020 11:34:17

CH11 – 10th Harmonic of the fundamental frequency

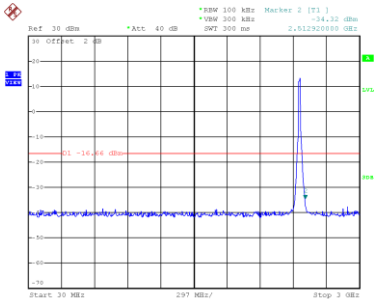

Date: 23_JUL_2020 11:40:48

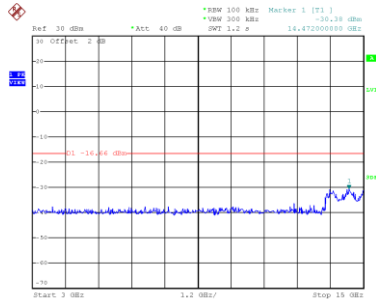

Date: 23_JUL_2020 11:40:55

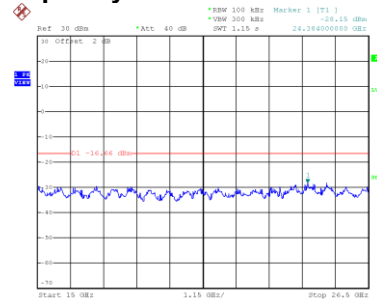

Date: 23_JUL_2020 11:41:02

Test Mode TX AX (HE40) Mode_Ant. 1

Bandedge-CH03

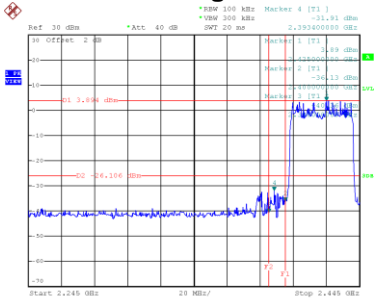

Date: 23_JUL_2020 12:11:059

Bandedge-CH09

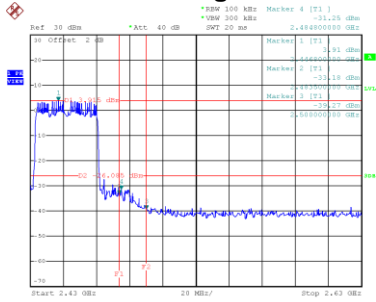

Date: 23_JUL_2020 12:12:156

CH03 – 10th Harmonic of the fundamental frequency

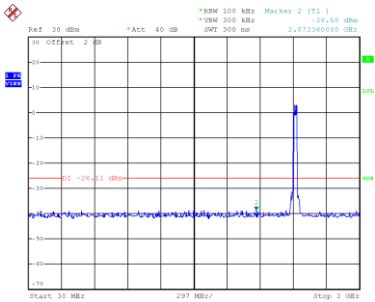

Date: 23_JUL_2020 12:11:132

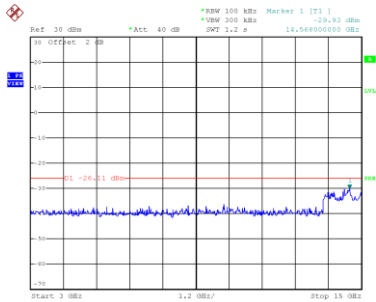

Date: 23_JUL_2020 12:11:139

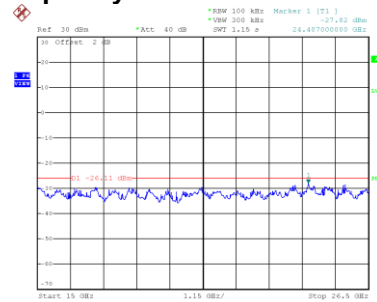

Date: 23_JUL_2020 12:11:146

CH06 – 10th Harmonic of the fundamental frequency

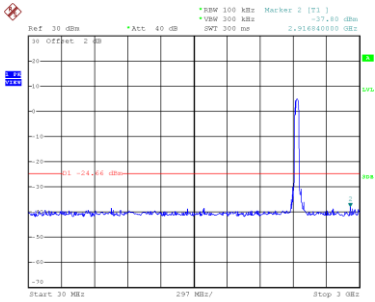

Date: 23_JUL_2020 12:12:413

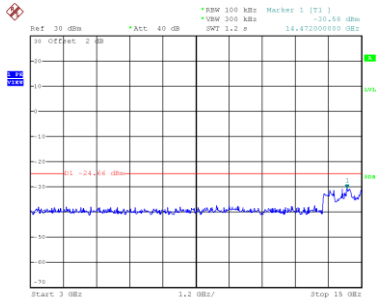

Date: 23_JUL_2020 12:12:420

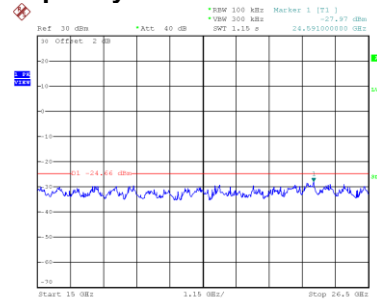

Date: 23_JUL_2020 12:12:427

CH09 – 10th Harmonic of the fundamental frequency

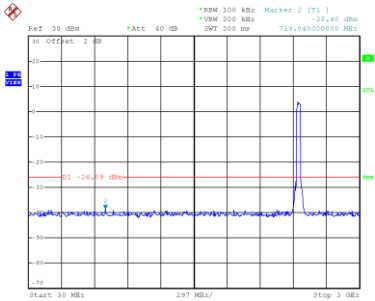

Date: 23_JUL_2020 12:12:929

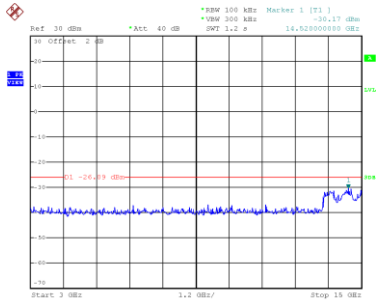

Date: 23_JUL_2020 12:12:936

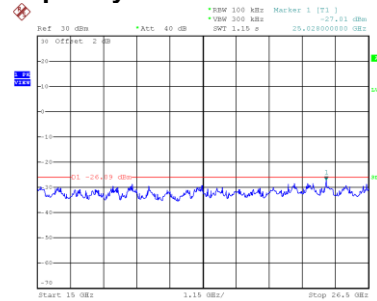

Date: 23_JUL_2020 12:12:943

Test Mode

TX AX (HE40) Mode_Ant. 2

Bandedge-CH03

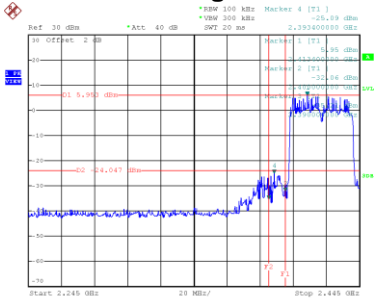

Date: 23_JUL_2020 12:05:25

Bandedge-CH09

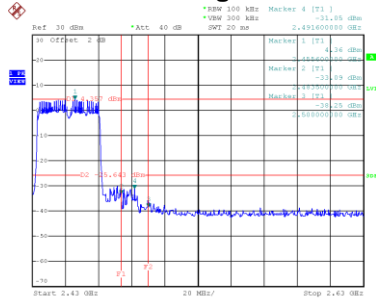

Date: 23_JUL_2020 12:27:23

CH03 – 10th Harmonic of the fundamental frequency

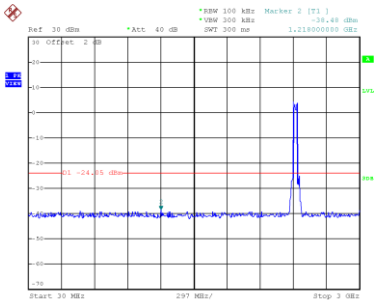

Date: 23_JUL_2020 12:05:58

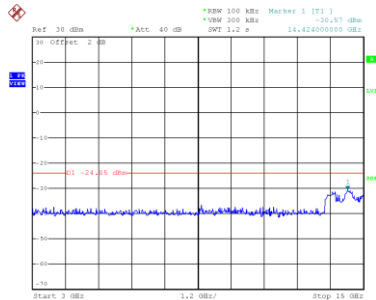

Date: 23_JUL_2020 12:06:05

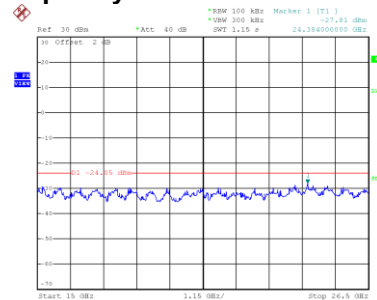

Date: 23_JUL_2020 12:06:12

CH06 – 10th Harmonic of the fundamental frequency

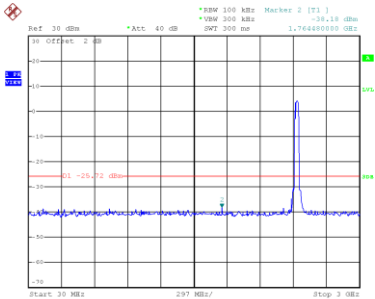

Date: 23_JUL_2020 12:26:09

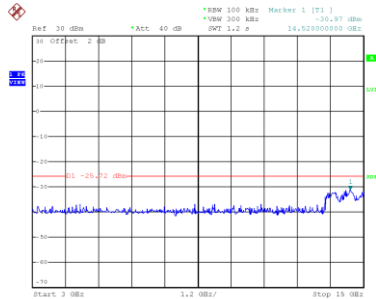

Date: 23_JUL_2020 12:26:16

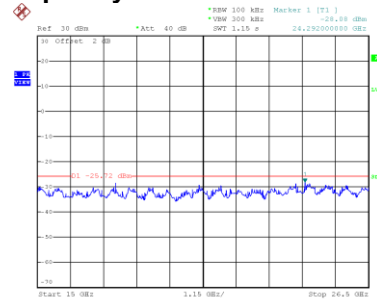

Date: 23_JUL_2020 12:26:23

CH09 – 10th Harmonic of the fundamental frequency

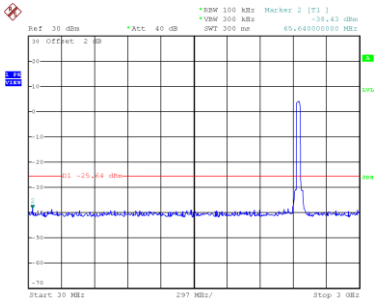

Date: 23_JUL_2020 12:27:55

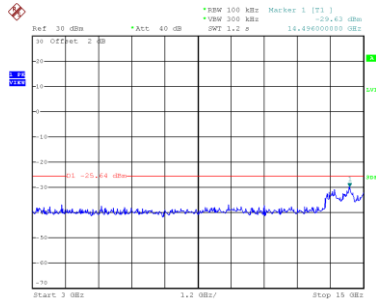

Date: 23_JUL_2020 12:28:02

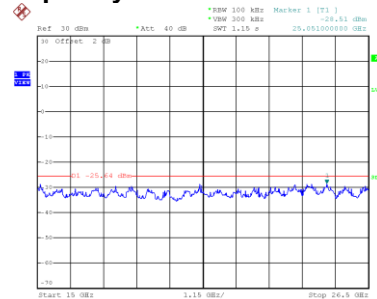

Date: 23_JUL_2020 12:28:09

APPENDIX H - POWER SPECTRAL DENSITY

CDD

Test Mode	TX AX (HE20) Mode_Ant. 1
-----------	--------------------------

Channel	Frequency (MHz)	Power Spectral Density (dBm/3kHz)	Max. Limit (dBm/3kHz)	Result
01	2412	-7.81	5.99	Complies
06	2437	-1.23	5.99	Complies
11	2462	-0.88	5.99	Complies

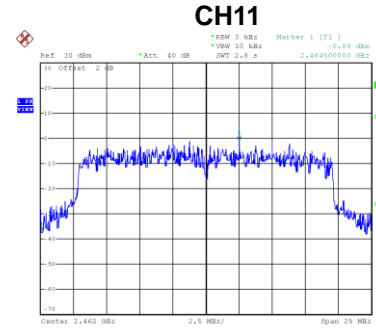
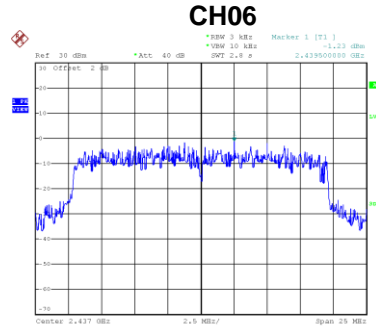
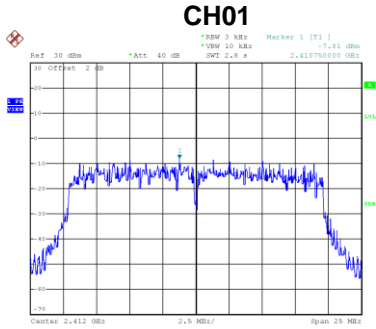

Test Mode	TX AX (HE20) Mode_Ant. 2
-----------	--------------------------

Channel	Frequency (MHz)	Power Spectral Density (dBm/3kHz)	Max. Limit (dBm/3kHz)	Result
01	2412	-7.14	5.99	Complies
06	2437	-0.1	5.99	Complies
11	2462	-0.41	5.99	Complies

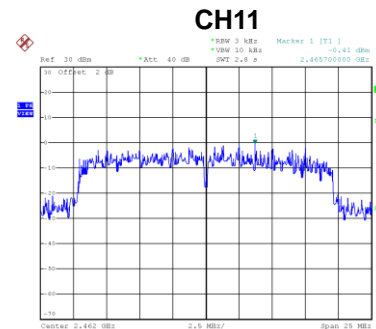
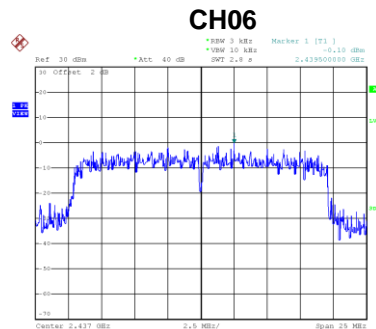
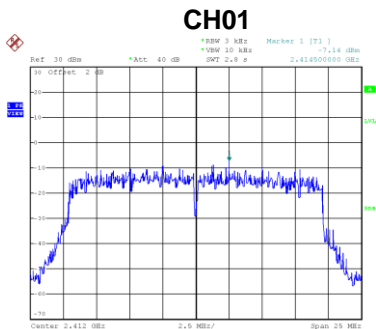

Test Mode	TX AX (HE20) Mode_Total
-----------	-------------------------

Channel	Frequency (MHz)	Power Spectral Density (dBm/3kHz)	Max. Limit (dBm/3kHz)	Result
01	2412	-1.52	5.99	Complies
06	2437	5.32	5.99	Complies
11	2462	5.31	5.99	Complies

Test Mode TX AX (HE40) Mode_Ant. 1

Channel	Frequency (MHz)	Power Spectral Density (dBm/3kHz)	Max. Limit (dBm/3kHz)	Result
03	2422	-13.92	5.99	Complies
06	2437	-9.47	5.99	Complies
09	2452	-9.15	5.99	Complies

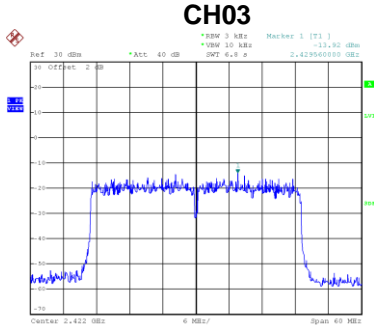

Date: 23.JUL.2020 12:11:58

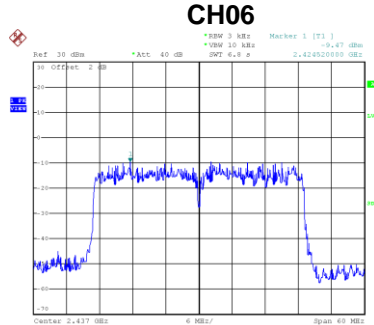

Date: 23.JUL.2020 12:24:39

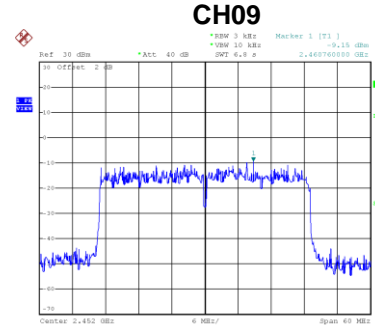

Date: 23.JUL.2020 12:29:54

Test Mode TX AX (HE40) Mode_Ant. 2

Channel	Frequency (MHz)	Power Spectral Density (dBm/3kHz)	Max. Limit (dBm/3kHz)	Result
03	2422	-12.97	5.99	Complies
06	2437	-7.82	5.99	Complies
09	2452	-9.07	5.99	Complies

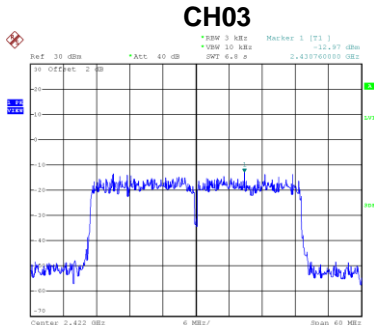

Date: 23.JUL.2020 12:06:24

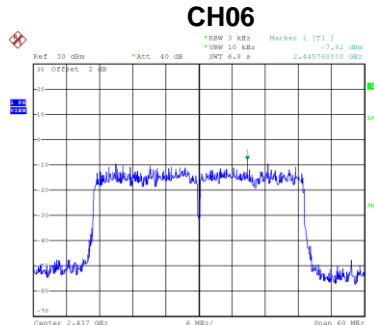

Date: 23.JUL.2020 12:26:34

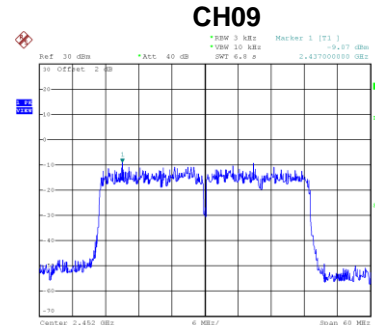

Date: 23.JUL.2020 12:28:21

Test Mode TX AX (HE40) Mode_Total

Channel	Frequency (MHz)	Power Spectral Density (dBm/3kHz)	Max. Limit (dBm/3kHz)	Result
03	2422	-7.27	5.99	Complies
06	2437	-2.42	5.99	Complies
09	2452	-2.97	5.99	Complies

End of Test Report