

FCC Test Report

Report No.: RF191028E02-1

FCC ID: KA2IRX1860A1

Test Model: DIR-X1860

Received Date: Oct. 28, 2019

Test Date: Nov. 01 ~ Nov. 19, 2019

Issued Date: Nov. 19, 2019

Applicant: D-Link Corporation

Address: No. 289, Xinhua 3rd Rd., Neihu District, Taipei City 11494, Taiwan

Issued By: Bureau Veritas Consumer Products Services (H.K.) Ltd., Taoyuan Branch
Lin Kou Laboratories

Lab Address: No. 47-2, 14th Ling, Chia Pau Vil., Lin Kou Dist., New Taipei City, Taiwan

Test Location: No. 19, Hwa Ya 2nd Rd., Wen Hwa Vil., Kwei Shan Dist., Taoyuan City
33383, TAIWAN

**FCC Registration /
Designation Number:** 788550 / TW0003



This report is for your exclusive use. Any copying or replication of this report to or for any other person or entity, or use of our name or trademark, is permitted only with our prior written permission. This report sets forth our findings solely with respect to the test samples identified herein. The results set forth in this report are not indicative or representative of the quality or characteristics of the lot from which a test sample was taken or any similar or identical product unless specifically and expressly noted. Our report includes all of the tests requested by you and the results thereof based upon the information that you provided to us. You have 60 days from date of issuance of this report to notify us of any material error or omission caused by our negligence, provided, however, that such notice shall be in writing and shall specifically address the issue you wish to raise. A failure to raise such issue within the prescribed time shall constitute your unqualified acceptance of the completeness of this report, the tests conducted and the correctness of the report contents. Unless specific mention, the uncertainty of measurement has been explicitly taken into account to declare the compliance or non-compliance to the specification. The report must not be used by the client to claim product certification, approval, or endorsement by TAF or any government agencies.

Table of Contents

Release Control Record	4
1 Certificate of Conformity	5
2 Summary of Test Results	6
2.1 Measurement Uncertainty.....	6
2.2 Modification Record.....	6
3 General Information	7
3.1 General Description of EUT.....	7
3.2 Description of Test Modes.....	10
3.2.1 Test Mode Applicability and Tested Channel Detail.....	11
3.3 Duty Cycle of Test Signal.....	13
3.4 Description of Support Units.....	14
3.4.1 Configuration of System under Test.....	14
3.5 General Description of Applied Standards.....	14
4 Test Types and Results	15
4.1 Radiated Emission and Bandedge Measurement.....	15
4.1.1 Limits of Radiated Emission and Bandedge Measurement.....	15
4.1.2 Test Instruments.....	16
4.1.3 Test Procedures.....	17
4.1.4 Deviation from Test Standard.....	17
4.1.5 Test Setup.....	18
4.1.6 EUT Operating Conditions.....	19
4.1.7 Test Results.....	20
4.2 Conducted Emission Measurement.....	42
4.2.1 Limits of Conducted Emission Measurement.....	42
4.2.2 Test Instruments.....	42
4.2.3 Test Procedures.....	43
4.2.4 Deviation from Test Standard.....	43
4.2.5 Test Setup.....	43
4.2.6 EUT Operating Conditions.....	43
4.2.7 Test Results.....	44
4.3 Transmit Power Measurement.....	48
4.3.1 Limits of Transmit Power Measurement.....	48
4.3.2 Test Setup.....	48
4.3.3 Test Instruments.....	48
4.3.4 Test Procedure.....	48
4.3.5 Deviation from Test Standard.....	48
4.3.6 EUT Operating Conditions.....	48
4.3.7 Test Result.....	49
4.4 Occupied Bandwidth Measurement.....	53
4.4.1 Test Setup.....	53
4.4.2 Test Instruments.....	53
4.4.3 Test Procedure.....	53
4.4.4 Test Result.....	54
4.5 Peak Power Spectral Density Measurement.....	58
4.5.1 Limits of Peak Power Spectral Density Measurement.....	58
4.5.2 Test Setup.....	58
4.5.3 Test Instruments.....	58
4.5.4 Test Procedures.....	58
4.5.5 Deviation from Test Standard.....	59
4.5.6 EUT Operating Conditions.....	59
4.5.7 Test Results.....	60
4.6 Frequency Stability.....	65
4.6.1 Limits of Frequency Stability Measurement.....	65

4.6.2	Test Setup.....	65
4.6.3	Test Instruments	65
4.6.4	Test Procedure	65
4.6.5	Deviation from Test Standard	66
4.6.6	EUT Operating Condition	66
4.6.7	Test Results	66
4.7	6dB Bandwidth Measurement.....	67
4.7.1	Limits of 6dB Bandwidth Measurement.....	67
4.7.2	Test Setup.....	67
4.7.3	Test Instruments	67
4.7.4	Test Procedure	67
4.7.5	Deviation from Test Standard	67
4.7.6	EUT Operating Condition	67
4.7.7	Test Results	68
5	Pictures of Test Arrangements.....	70
	Annex A- Radiated Out of Band Emission (OOBE) Measurement (For U-NII-3 band).....	71
	Appendix – Information of the Testing Laboratories	74

Release Control Record

Issue No.	Description	Date Issued
RF191028E02-1	Original release	Nov. 19, 2019

1 Certificate of Conformity

Product: Smart AX1800 Wi-Fi 6 Router

Brand: D-Link

Test Model: DIR-X1860

Sample Status: Engineering sample

Applicant: D-Link Corporation

Test Date: Nov. 01 ~ Nov. 19, 2019

Standards: 47 CFR FCC Part 15, Subpart E (Section 15.407)
ANSI C63.10:2013

The above equipment has been tested by **Bureau Veritas Consumer Products Services (H.K.) Ltd., Taoyuan Branch**, and found compliance with the requirement of the above standards. The test record, data evaluation & Equipment Under Test (EUT) configurations represented herein are true and accurate accounts of the measurements of the sample's RF characteristics under the conditions specified in this report.

Prepared by : Celine Chou , **Date:** Nov. 19, 2019
Celine Chou / Senior Specialist

Approved by : Bruce Chen , **Date:** Nov. 19, 2019
Bruce Chen / Senior Project Engineer

2 Summary of Test Results

47 CFR FCC Part 15, Subpart E (Section 15.407)			
FCC Clause	Test Item	Result	Remarks
15.407(b)(6)	AC Power Conducted Emissions	Pass	Meet the requirement of limit. Minimum passing margin is -16.07dB at 0.42131MHz.
15.407(b)(1/2/3/4(i/ii)/6)	Radiated Emissions & Band Edge Measurement	Pass	Meet the requirement of limit. Minimum passing margin is -0.1dB at 5150.00MHz, 10400.00MHz and 5650.40MHz.
15.407(a)(1/2/3)	Max Average Transmit Power	Pass	Meet the requirement of limit.
---	Occupied Bandwidth Measurement	-	Reference only.
15.407(a)(1/2/3)	Peak Power Spectral Density	Pass	Meet the requirement of limit.
15.407(e)	6dB bandwidth	Pass	Meet the requirement of limit. (U-NII-3 Band only)
15.407(g)	Frequency Stability	Pass	Meet the requirement of limit.
15.203	Antenna Requirement	Pass	Antenna connector is i-pex(MHF) not a standard connector.

Note:

- Determining compliance based on the results of the compliance measurement, not taking into account measurement instrumentation uncertainty.
- For U-NII-3 band compliance with rule part 15.407(b)(4)(i), the OOB test plots were recorded in Annex A.

2.1 Measurement Uncertainty

Where relevant, the following measurement uncertainty levels have been estimated for tests performed on the EUT as specified in CISPR 16-4-2:

Measurement	Frequency	Expanded Uncertainty (k=2) (\pm)
Conducted Emissions at mains ports	150kHz ~ 30MHz	2.79 dB
Radiated Emissions up to 1 GHz	9kHz ~ 30MHz	3.04 dB
	30MHz ~ 200MHz	3.59 dB
	200MHz ~ 1000MHz	3.60 dB
Radiated Emissions above 1 GHz	1GHz ~ 18GHz	2.29 dB
	18GHz ~ 40GHz	2.29 dB

2.2 Modification Record

There were no modifications required for compliance.

3 General Information

3.1 General Description of EUT

Product	Smart AX1800 Wi-Fi 6 Router
Brand	D-Link
Test Model	DIR-X1860
Sample Status	Engineering sample
Power Supply Rating	12Vdc from adapter
Modulation Type	256QAM, 64QAM, 16QAM, QPSK, BPSK for OFDM 1024QAM for OFDMA
Modulation Technology	OFDM, OFDMA
Transfer Rate	802.11a: 54/48/36/24/18/12/9/6Mbps 802.11n: up to 300Mbps 802.11ac: up to 867Mbps 802.11ax: up to 1200Mbps
Operating Frequency	5180 ~ 5240MHz, 5745 ~ 5825MHz
Number of Channel	5180 ~ 5240MHz: 802.11a, 802.11n (HT20), 802.11ac (VHT20), 802.11ax (HE20): 4 802.11n (HT40), 802.11ac (VHT40), 802.11ax (HE40): 2 802.11ac (VHT80), 802.11ax (HE80): 1 5745 ~ 5825MHz: 802.11a, 802.11n (HT20), 802.11ac (VHT20), 802.11ax (HE20): 5 802.11n (HT40), 802.11ac (VHT40), 802.11ax (HE40): 2 802.11ac (VHT80), 802.11ax (HE80): 1
Output Power	CDD Mode: 5180 ~ 5240MHz: 433.107mW 5745 ~ 5825MHz: 449.830mW Beamforming Mode: 5180 ~ 5240MHz: 216.568mW 5745 ~ 5825MHz: 213.081mW
Antenna Type	Refer to note
Antenna Connector	Refer to note
Accessory Device	Adapter
Cable Supplied	1.8m non-shielded LAN cable without core

Note:

1. The EUT incorporates a MIMO function. Physically, the EUT provides 2 completed transmitters and 2 receivers.

Modulation Mode	Beamforming Mode	TX Function
802.11a	Not Support	2TX
802.11n (HT20)	Support	2TX
802.11n (HT40)	Support	2TX
802.11ac (VHT20)	Support	2TX
802.11ac (VHT40)	Support	2TX
802.11ac (VHT80)	Support	2TX
802.11ax (HE20)	Support	2TX
802.11ax (HE40)	Support	2TX
802.11ax (HE80)	Support	2TX

* The bandwidth and modulation are similar for HT20/HT40 on 802.11n mode and VHT20/VHT40/VHT80 on 802.11ac mode and HE20/HE40/HE80 on 802.11ax mode. Therefore the investigated worst case is the representative mode in test report. (Final test mode refer section 3.2.1)

* For 802.11n and 802.11ac, CDD mode and Beamforming mode are presented in power output test item. For other test items, CDD mode is the worst case for final tests after pretesting.

2. The EUT consumes power from the following adapters.

Adapter 1	
Brand	Channel Well Technology
Model	2AAJ018F
Input Power	100-240Vac, 50/60Hz, 0.6A
Output Power	12Vdc, 1.5A
Power Line	1.2m cable without core attached on adapter

Adapter 2	
Brand	AMIGO
Model	AMS200-1201500FU
Input Power	100-240Vac, 50/60Hz, 0.8A
Output Power	12Vdc, 1.5A
Power Line	1.2m cable without core attached on adapter

3. The antennas have two sources provided to the EUT, 1st source was chosen for final test.

1st Source

Ant. No.	RF Chain No.	Brand	Model	Gain (dBi)	Frequency range (GHz)	Ant. Type	Connector Type	Cable Length (mm)
2.4G-1	Chain0	HONGBO	290-20420	5.89	2.4~2.4835	Dipole	i-pex(MHF)	187.4
2.4G-2	Chain1	HONGBO	290-20419	5.48	2.4~2.4835	Dipole	i-pex(MHF)	287.4
5G-1	Chain0	HONGBO	290-20422	5.73	5.15~5.25	Dipole	i-pex(MHF)	211
	Chain0			5.30	5.25~5.35	Dipole	i-pex(MHF)	
	Chain0			5.76	5.47~5.725	Dipole	i-pex(MHF)	
	Chain0			5.76	5.725~5.85	Dipole	i-pex(MHF)	
5G-2	Chain1	HONGBO	290-20421	5.32	5.15~5.25	Dipole	i-pex(MHF)	291
	Chain1			5.78	5.25~5.35	Dipole	i-pex(MHF)	
	Chain1			5.77	5.47~5.725	Dipole	i-pex(MHF)	
	Chain1			5.77	5.725~5.85	Dipole	i-pex(MHF)	

2nd Source

Ant. No.	RF Chain No.	Brand	Model	Gain (dBi)	Frequency range (GHz)	Ant. Type	Connector Type	Cable Length (mm)
2.4G-1	Chain0	RFLINK	RF21C04609A	5.11	2.4~2.4835	Dipole	i-pex(MHF)	215
2.4G-2	Chain1	RFLINK	RF21C04610A	5.22	2.4~2.4835	Dipole	i-pex(MHF)	115
5G-1	Chain0	RFLINK	RF21C04611A	4.87	5.15~5.25	Dipole	i-pex(MHF)	220
	Chain0			5.40	5.25~5.35	Dipole	i-pex(MHF)	
	Chain0			5.10	5.47~5.725	Dipole	i-pex(MHF)	
	Chain0			5.04	5.725~5.85	Dipole	i-pex(MHF)	
5G-2	Chain1	RFLINK	RF21C04612A	5.36	5.15~5.25	Dipole	i-pex(MHF)	140
	Chain1			5.29	5.25~5.35	Dipole	i-pex(MHF)	
	Chain1			5.48	5.47~5.725	Dipole	i-pex(MHF)	
	Chain1			5.22	5.725~5.85	Dipole	i-pex(MHF)	

4. 2.4GHz & 5GHz technology cannot transmit at same time.

3.2 Description of Test Modes

For 5180 ~ 5240MHz:

4 channels are provided for 802.11a, 802.11n (HT20), 802.11ac (VHT20), 802.11ax (HE20):

Channel	Frequency	Channel	Frequency
36	5180 MHz	44	5220 MHz
40	5200 MHz	48	5240 MHz

2 channels are provided for 802.11n (HT40), 802.11ac (VHT40), 802.11ax (HE40):

Channel	Frequency	Channel	Frequency
38	5190 MHz	46	5230 MHz

1 channel is provided for 802.11ac (VHT80), 802.11ax (HE80):

Channel	Frequency
42	5210MHz

For 5745 ~ 5825MHz:

5 channels are provided for 802.11a, 802.11n (HT20), 802.11ac (VHT20), 802.11ax (HE20):

Channel	Frequency	Channel	Frequency
149	5745MHz	161	5805MHz
153	5765MHz	165	5825MHz
157	5785MHz		

2 channels are provided for 802.11n (HT40), 802.11ac (VHT40), 802.11ax (HE40):

Channel	Frequency	Channel	Frequency
151	5755MHz	159	5795MHz

1 channel is provided for 802.11ac (VHT80), 802.11ax (HE80):

Channel	Frequency
155	5775MHz

3.2.1 Test Mode Applicability and Tested Channel Detail

EUT Configure Mode	Applicable to				Description
	RE≥1G	RE<1G	PLC	APCM	
A	√	√	√	√	Power by adapter 1
B	-	√	√	-	Power by adapter 2

Where RE≥1G: Radiated Emission above 1GHz & Bandedge Measurement
 RE<1G: Radiated Emission below 1GHz
 PLC: Power Line Conducted Emission
 APCM: Antenna Port Conducted Measurement

Note:

- The EUT had been pre-tested on the positioned of each 3 axis. The worst case was found when positioned on **X-plane**.
- Radiated emission test (below 1GHz) and power line conducted emission test items chosen the worst maximum power.

Radiated Emission Test (Above 1GHz):

- Pre-Scan has been conducted to determine the worst-case mode from all possible combinations between available modulations, data rates and antenna ports (if EUT with antenna diversity architecture).
- Following channel(s) was (were) selected for the final test as listed below.

EUT Configure Mode	Mode	Frequency Band (MHz)	Available Channel	Tested Channel	Modulation Technology	Data Rate (Mbps)
A	802.11a	5180-5240	36 to 48	36, 40, 48	OFDM	6.0
	802.11ax (HE20)		36 to 48	36, 40, 48	OFDMA	MCS0
	802.11ax (HE40)		38 to 46	38, 46	OFDMA	MCS0
	802.11ax (HE80)		42	42	OFDMA	MCS0
A	802.11a	5745-5825	149 to 165	149, 157, 165	OFDM	6.0
	802.11ax (HE20)		149 to 165	149, 157, 165	OFDMA	MCS0
	802.11ax (HE40)		151 to 159	151, 159	OFDMA	MCS0
	802.11ax (HE80)		155	155	OFDMA	MCS0

Radiated Emission Test (Below 1GHz):

- Pre-Scan has been conducted to determine the worst-case mode from all possible combinations between available modulations, data rates and antenna ports (if EUT with antenna diversity architecture).
- Following channel(s) was (were) selected for the final test as listed below.

EUT Configure Mode	Mode	Frequency Band (MHz)	Available Channel	Tested Channel	Modulation Technology	Data Rate (Mbps)
A, B	802.11a	5180-5240	36 to 48	157	OFDM	6.0
	802.11a	5745-5825	149 to 165		OFDM	6.0

Power Line Conducted Emission Test:

- Pre-Scan has been conducted to determine the worst-case mode from all possible combinations between available modulations, data rates and antenna ports (if EUT with antenna diversity architecture).
- Following channel(s) was (were) selected for the final test as listed below.

EUT Configure Mode	Mode	Frequency Band (MHz)	Available Channel	Tested Channel	Modulation Technology	Data Rate (Mbps)
A, B	802.11a	5180-5240	36 to 48	157	OFDM	6.0
	802.11a	5745-5825	149 to 165		OFDM	6.0

Transmit Power Measurement:

- This item includes all test value of each mode, but only includes spectrum plot of worst value of each mode.
- Pre-Scan has been conducted to determine the worst-case mode from all possible combinations between available modulations, data rates and antenna ports (if EUT with antenna diversity architecture).
- Following channel(s) was (were) selected for the final test as listed below.

EUT Configure Mode	Mode	Frequency Band (MHz)	Available Channel	Tested Channel	Modulation Technology	Data Rate (Mbps)
A	802.11a	5180-5240	36 to 48	36, 40, 48	OFDM	6.0
	802.11ac (VHT20)		36 to 48	36, 40, 48	OFDM	6.5
	802.11ac (VHT40)		38 to 46	38, 46	OFDM	13.5
	802.11ac (VHT80)		42	42	OFDM	29.3
	802.11ax (HE20)		36 to 48	36, 40, 48	OFDMA	MCS0
	802.11ax (HE40)		38 to 46	38, 46	OFDMA	MCS0
	802.11ax (HE80)		42	42	OFDMA	MCS0
A	802.11a	5745-5825	149 to 165	149, 157, 165	OFDM	6.0
	802.11ac (VHT20)		149 to 165	149, 157, 165	OFDM	6.5
	802.11ac (VHT40)		151 to 159	151, 159	OFDM	13.5
	802.11ac (VHT80)		155	155	OFDM	29.3
	802.11ax (HE20)		149 to 165	149, 157, 165	OFDMA	MCS0
	802.11ax (HE40)		151 to 159	151, 159	OFDMA	MCS0
	802.11ax (HE80)		155	155	OFDMA	MCS0

Bandwidth, Peak Power Spectral Density and Frequency Stability Measurement:

- This item includes all test value of each mode, but only includes spectrum plot of worst value of each mode.
- Pre-Scan has been conducted to determine the worst-case mode from all possible combinations between available modulations, data rates and antenna ports (if EUT with antenna diversity architecture).
- Following channel(s) was (were) selected for the final test as listed below.

EUT Configure Mode	Mode	Frequency Band (MHz)	Available Channel	Tested Channel	Modulation Technology	Data Rate (Mbps)
A	802.11a	5180-5240	36 to 48	36, 40, 48	OFDM	6.0
	802.11ax (HE20)		36 to 48	36, 40, 48	OFDMA	MCS0
	802.11ax (HE40)		38 to 46	38, 46	OFDMA	MCS0
	802.11ax (HE80)		42	42	OFDMA	MCS0
A	802.11a	5745-5825	149 to 165	149, 157, 165	OFDM	6.0
	802.11ax (HE20)		149 to 165	149, 157, 165	OFDMA	MCS0
	802.11ax (HE40)		151 to 159	151, 159	OFDMA	MCS0
	802.11ax (HE80)		155	155	OFDMA	MCS0

Test Condition:

Applicable to	Environmental Conditions	Input Power	Tested by
RE \geq 1G	22 deg. C, 68% RH 22 deg. C, 66% RH	120Vac, 60Hz	Han Wu
RE<1G	22 deg. C, 66% RH	120Vac, 60Hz	Han Wu
PLC	25 deg. C, 75% RH	120Vac, 60Hz	Jones Chang
APCM	25 deg. C, 60% RH	120Vac, 60Hz	Jisyong Wang

3.3 Duty Cycle of Test Signal

Duty cycle of test signal is < 98%, duty factor is required.

802.11a: Duty cycle = 1.392/1.452 = 0.959, Duty factor = $10 \cdot \log(1/0.959) = 0.18$

802.11ax (HE20): Duty cycle = 1.015/1.084 = 0.936, Duty factor = $10 \cdot \log(1/0.936) = 0.29$

802.11ax (HE40): Duty cycle = 0.536/0.596 = 0.899, Duty factor = $10 \cdot \log(1/0.899) = 0.46$

802.11ax (HE80): Duty cycle = 0.286/0.347 = 0.824, Duty factor = $10 \cdot \log(1/0.824) = 0.84$

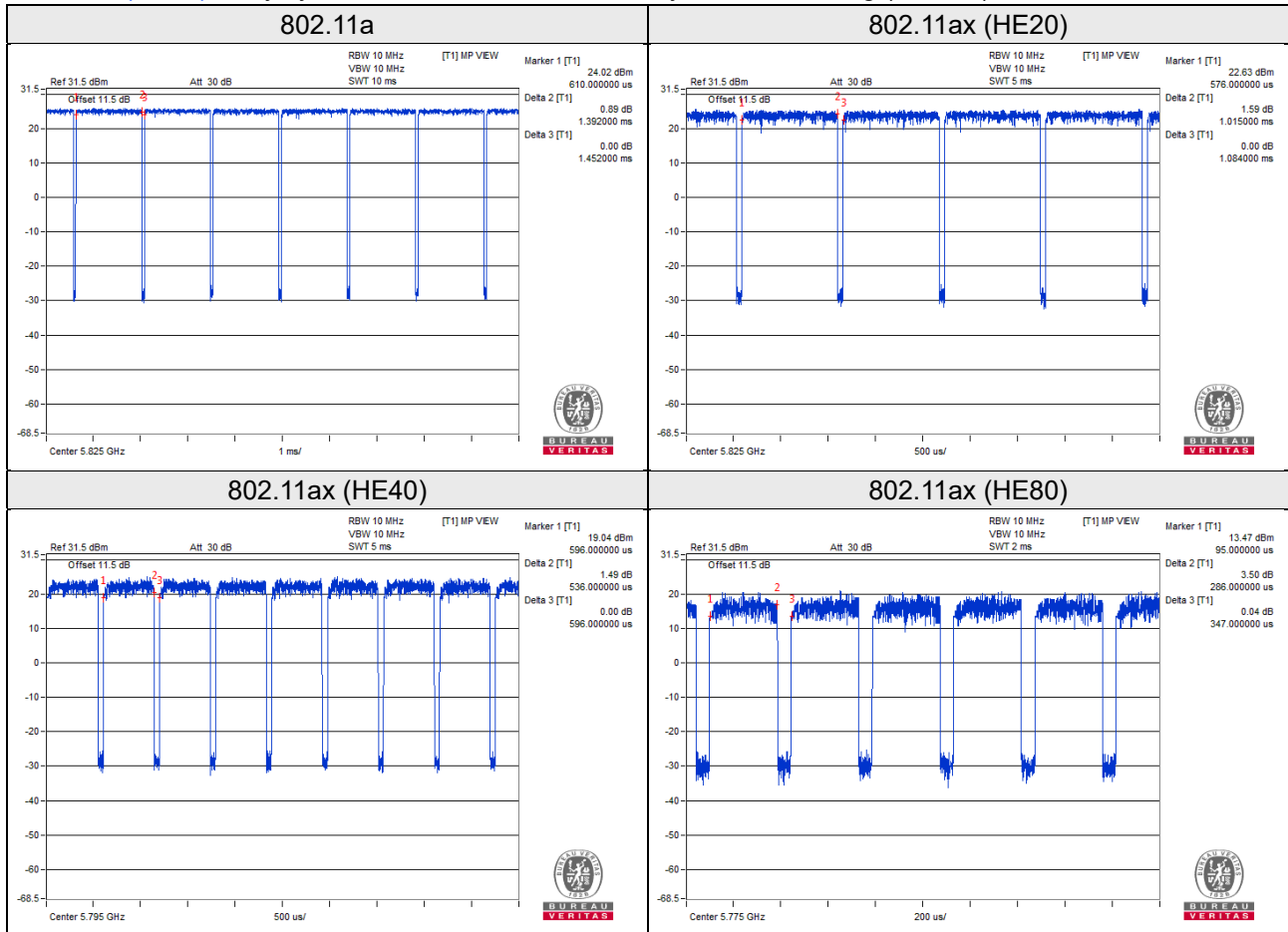

3.4 Description of Support Units

The EUT has been tested as an independent unit.

3.4.1 Configuration of System under Test

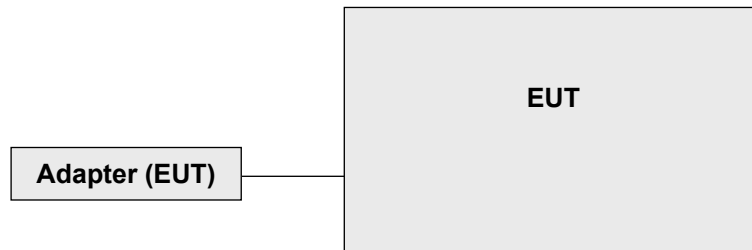

3.5 General Description of Applied Standards

The EUT is a RF Product. According to the specifications of the manufacturer, it must comply with the requirements of the following standards:

FCC Part 15, Subpart E (15.407)

KDB 789033 D02 General UNII Test Procedure New Rules v02r01

KDB 662911 D01 Multiple Transmitter Output v02r01

ANSI C63.10:2013

All test items have been performed and recorded as per the above standards.

4 Test Types and Results

4.1 Radiated Emission and Bandedge Measurement

4.1.1 Limits of Radiated Emission and Bandedge Measurement

Radiated emissions which fall in the restricted bands must comply with the radiated emission limits specified as below table.

Frequencies (MHz)	Field Strength (microvolts/meter)	Measurement Distance (meters)
0.009 ~ 0.490	2400/F(kHz)	300
0.490 ~ 1.705	24000/F(kHz)	30
1.705 ~ 30.0	30	30
30 ~ 88	100	3
88 ~ 216	150	3
216 ~ 960	200	3
Above 960	500	3

Note:

1. The lower limit shall apply at the transition frequencies.
2. Emission level (dBuV/m) = 20 log Emission level (uV/m).
3. For frequencies above 1000MHz, the field strength limits are based on average detector, however, the peak field strength of any emission shall not exceed the maximum permitted average limits, specified above by more than 20dB under any condition of modulation.

Limits of unwanted emission out of the restricted bands

Applicable To		Limit	
789033 D02 General UNII Test Procedure New Rules v02r01		Field Strength at 3m	
		PK: 74 (dBµV/m)	AV: 54 (dBµV/m)
Frequency Band	Applicable To	EIRP Limit	Equivalent Field Strength at 3m
5150~5250 MHz	15.407(b)(1)	PK: -27 (dBm/MHz)	PK: 68.2(dBµV/m)
5250~5350 MHz	15.407(b)(2)		
5470~5725 MHz	15.407(b)(3)		
5725~5850 MHz	<input checked="" type="checkbox"/> 15.407(b)(4)(i)	PK: -27 (dBm/MHz) ^{*1} PK: 10 (dBm/MHz) ^{*2} PK: 15.6 (dBm/MHz) ^{*3} PK: 27 (dBm/MHz) ^{*4}	PK: 68.2(dBµV/m) ^{*1} PK: 105.2 (dBµV/m) ^{*2} PK: 110.8(dBµV/m) ^{*3} PK: 122.2 (dBµV/m) ^{*4}
	<input type="checkbox"/> 15.407(b)(4)(ii)	Emission limits in section 15.247(d)	
^{*1} beyond 75 MHz or more above of the band edge.		^{*2} below the band edge increasing linearly to 10 dBm/MHz at 25 MHz above.	
^{*3} below the band edge increasing linearly to a level of 15.6 dBm/MHz at 5 MHz above.		^{*4} from 5 MHz above or below the band edge increasing linearly to a level of 27 dBm/MHz at the band edge.	

Note: The following formula is used to convert the equipment isotropic radiated power (eirp) to field strength:

$$E = \frac{1000000 \sqrt{30P}}{3} \mu\text{V/m, where P is the eirp (Watts).}$$

4.1.2 Test Instruments

Description & Manufacturer	Model No.	Serial No.	Cal. Date	Cal. Due
Test Receiver KEYSIGHT	N9038A	MY55420137	Apr. 15, 2019	Apr. 14, 2020
Spectrum Analyzer ROHDE & SCHWARZ	FSP40	100269	Jun. 04, 2019	Jun. 03, 2020
BILOG Antenna SCHWARZBECK	VULB9168	9168-160	Nov. 21, 2018	Nov. 20, 2019
HORN Antenna SCHWARZBECK	BBHA 9120 D	9120D-1169	Nov. 25, 2018	Nov. 24, 2019
HORN Antenna SCHWARZBECK	BBHA 9170	BBHA9170241	Nov. 25, 2018	Nov. 24, 2019
Loop Antenna TESEQ	HLA 6121	45745	Jul. 01, 2019	Jun. 30, 2020
Preamplifier Agilent (Below 1GHz)	8447D	2944A10638	Jul. 11, 2019	Jul. 10, 2020
Preamplifier Agilent (Above 1GHz)	8449B	3008A02367	Feb. 19, 2019	Feb. 18, 2020
RF signal cable HUBER+SUHNER&EMCI	SUCOFLEX 104 & EMC104-SM-SM80 00	CABLE-CH9-02 (248780+171006)	Jan. 19, 2019	Jan. 18, 2020
RF signal cable HUBER+SUHNER	SUCOFLEX 104	CABLE-CH9-(250795/4)	Jul. 11, 2019	Jul. 10, 2020
RF signal cable Woken	8D-FB	Cable-CH9-01	Jul. 30, 2019	Jul. 29, 2020
Software BV ADT	ADT_Radiated_ V7.6.15.9.5	NA	NA	NA
Antenna Tower EMCO	2070/2080	512.835.4684	NA	NA
Turn Table EMCO	2087-2.03	NA	NA	NA
Antenna Tower & Turn BV ADT	AT100	AT93021705	NA	NA
Turn Table BV ADT	TT100	TT93021705	NA	NA
Turn Table Controller BV ADT	SC100	SC93021705	NA	NA
Boresight Antenna Fixture	FBA-01	FBA-SIP01	NA	NA
Pre-amplifier (18GHz-40GHz) EMC	EMC184045B	980175	Nov. 14, 2018	Nov. 13, 2019
			Sep. 05, 2019	Sep. 04, 2020
USB Wideband Power Sensor KEYSIGHT	U2021XA	MY55050005/MY55190 004/MY55190007/MY55 210005	Jul. 15, 2019	Jul. 14, 2020
Peak Power Analyzer KEYSIGHT (Support 8TX and 160MHz Bandwidth)	8990B	MY51000485	Jan. 14, 2019	Jan. 13, 2020

Note: 1. The calibration interval of the above test instruments is 12 months and the calibrations are traceable to NML/ROC and NIST/USA.
2. The test was performed in HwaYa Chamber 9.

4.1.3 Test Procedures

For Radiated emission below 30MHz

- a. The EUT was placed on the top of a rotating table 0.8 meters above the ground at a 3 meter chamber room. The table was rotated 360 degrees to determine the position of the highest radiation.
- b. The EUT was set 3 meters away from the interference-receiving antenna, which was mounted on the top of a variable-height antenna tower.
- c. Parallel, perpendicular, and ground-parallel orientations of the antenna are set to make the measurement.
- d. For each suspected emission, the EUT was arranged to its worst case and the rotatable table was turned from 0 degrees to 360 degrees to find the maximum reading.
- e. The test-receiver system was set to Quasi-Peak Detect Function and Specified Bandwidth with Maximum Hold Mode.

Note:

1. The resolution bandwidth and video bandwidth of test receiver/spectrum analyzer is 9kHz at frequency below 30MHz.

For Radiated emission above 30MHz

- a. The EUT was placed on the top of a rotating table 0.8 meters (for 30MHz ~ 1GHz) / 1.5 meters (for above 1GHz) above the ground at 3 meter chamber room for test. The table was rotated 360 degrees to determine the position of the highest radiation.
- b. The EUT was set 3 meters away from the interference-receiving antenna, which was mounted on the top of a variable-height antenna tower.
- c. The height of antenna is varied from one meter to four meters above the ground to determine the maximum value of the field strength. Both horizontal and vertical polarizations of the antenna are set to make the measurement.
- d. For each suspected emission, the EUT was arranged to its worst case and then the antenna was tuned to heights from 1 meter to 4 meters and the rotatable table was turned from 0 degrees to 360 degrees to find the maximum reading.
- e. The test-receiver system was set to quasi-peak detect function and specified bandwidth with maximum hold mode when the test frequency is below 1 GHz.
- f. The test-receiver system was set to peak and average detect function and specified bandwidth with maximum hold mode when the test frequency is above 1 GHz. If the peak reading value also meets average limit, measurement with the average detector is unnecessary.

Note:

1. The resolution bandwidth and video bandwidth of test receiver/spectrum analyzer is 120kHz for Quasi-peak detection (QP) at frequency below 1GHz.
2. The resolution bandwidth of test receiver/spectrum analyzer is 1 MHz and the video bandwidth is 3 MHz for Peak detection (PK) at frequency above 1GHz.
3. The resolution bandwidth of test receiver/spectrum analyzer is 1MHz and the video bandwidth is $\geq 1/T$ (Duty cycle < 98%) or 10Hz (Duty cycle $\geq 98\%$) for Average detection (AV) at frequency above 1GHz. (802.11a: RBW = 1MHz, VBW = 1kHz; 802.11ax (HE20): RBW = 1MHz, VBW = 1kHz; 802.11ax (HE40): RBW = 1MHz, VBW = 3kHz; 802.11ax (HE80): RBW = 1MHz, VBW = 10kHz)
4. All modes of operation were investigated and the worst-case emissions are reported.

4.1.4 Deviation from Test Standard

No deviation.

4.1.5 Test Setup

For Radiated emission below 30MHz

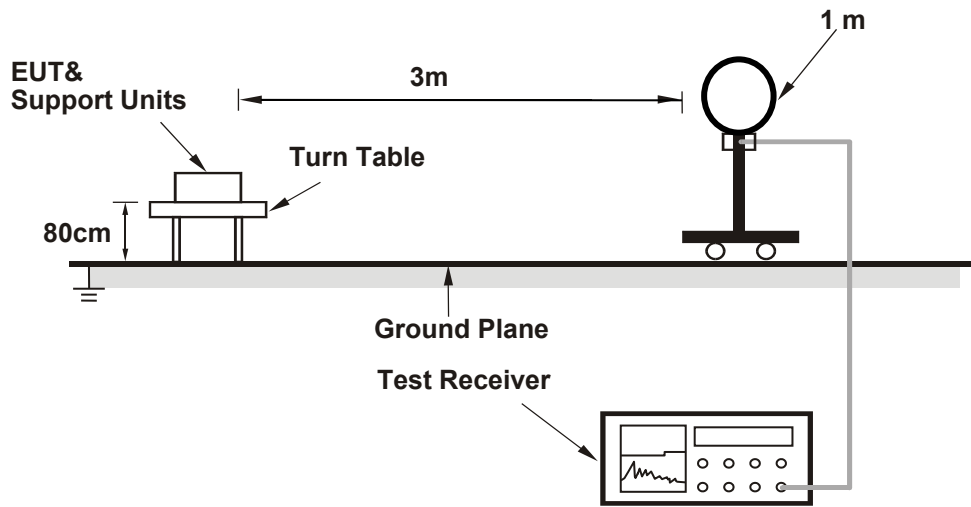

For Radiated emission 30MHz to 1GHz

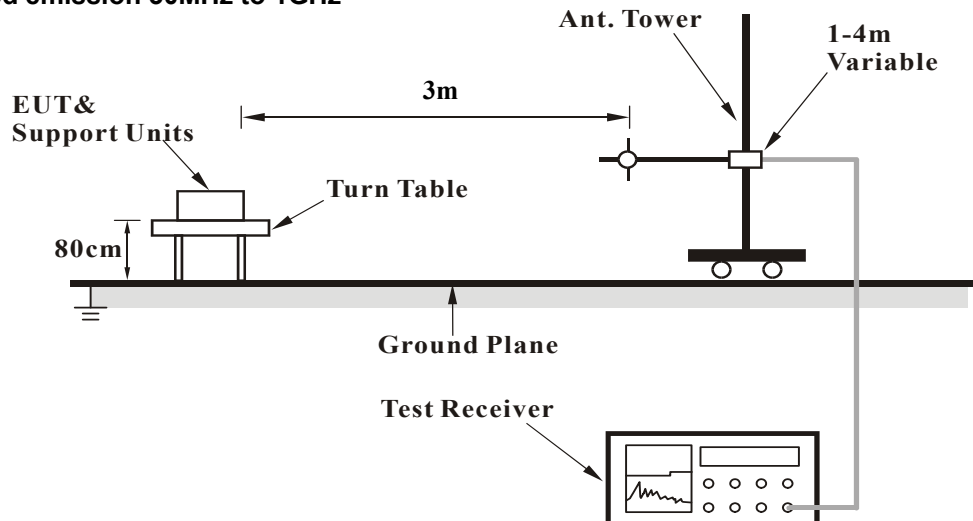

For Radiated emission above 1GHz

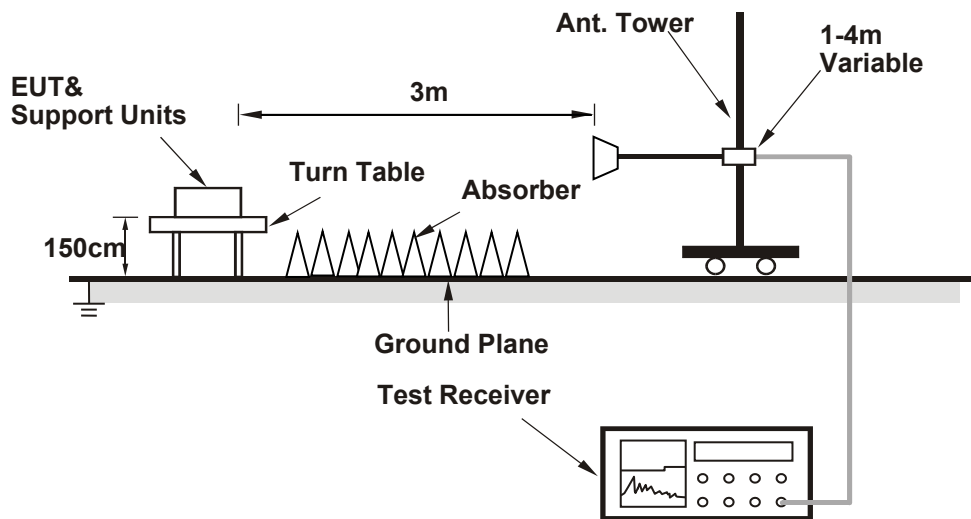

For the actual test configuration, please refer to the attached file (Test Setup Photo).

4.1.6 EUT Operating Conditions

- Set the EUT under transmission condition continuously at specific channel frequency.

4.1.7 Test Results

Above 1GHz data:

802.11a

CHANNEL	TX Channel 36	DETECTOR FUNCTION	Peak (PK) Average (AV)
FREQUENCY RANGE	1GHz ~ 40GHz		

ANTENNA POLARITY & TEST DISTANCE: HORIZONTAL AT 3 M

NO.	FREQ. (MHz)	EMISSION LEVEL (dBuV/m)	LIMIT (dBuV/m)	MARGIN (dB)	ANTENNA HEIGHT (m)	TABLE ANGLE (Degree)	RAW VALUE (dBuV)	CORRECTION FACTOR (dB/m)
1	5150.00	62.2 PK	74.0	-11.8	1.49 H	325	58.1	4.1
2	5150.00	41.3 AV	54.0	-12.7	1.49 H	325	37.2	4.1
3	*5180.00	107.3 PK			1.56 H	329	68.8	38.5
4	*5180.00	99.0 AV			1.56 H	329	60.5	38.5
5	#10360.00	62.5 PK	68.2	-5.7	1.44 H	130	46.0	16.5

ANTENNA POLARITY & TEST DISTANCE: VERTICAL AT 3 M

NO.	FREQ. (MHz)	EMISSION LEVEL (dBuV/m)	LIMIT (dBuV/m)	MARGIN (dB)	ANTENNA HEIGHT (m)	TABLE ANGLE (Degree)	RAW VALUE (dBuV)	CORRECTION FACTOR (dB/m)
1	5150.00	73.6 PK	74.0	-0.4	1.46 V	147	69.5	4.1
2	5150.00	50.0 AV	54.0	-4.0	1.46 V	147	45.9	4.1
3	*5180.00	120.6 PK			1.35 V	149	82.1	38.5
4	*5180.00	111.3 AV			1.35 V	149	72.8	38.5
5	#10360.00	67.4 PK	68.2	-0.8	1.39 V	9	50.9	16.5

Remarks:

1. Emission Level(dBuV/m) = Raw Value(dBuV) + Correction Factor(dB/m).
2. Correction Factor(dB/m) = Antenna Factor(dB/m) + Cable Factor(dB) – Pre-Amplifier Factor(dB).
3. Margin value = Emission Level – Limit value.
4. The other emission levels were very low against the limit.
5. " * ": Fundamental frequency.
6. " # ": The radiated frequency is out of the restricted band.

CHANNEL	TX Channel 40	DETECTOR FUNCTION	Peak (PK) Average (AV)
FREQUENCY RANGE	1GHz ~ 40GHz		

ANTENNA POLARITY & TEST DISTANCE: HORIZONTAL AT 3 M

NO.	FREQ. (MHz)	EMISSION LEVEL (dBuV/m)	LIMIT (dBuV/m)	MARGIN (dB)	ANTENNA HEIGHT (m)	TABLE ANGLE (Degree)	RAW VALUE (dBuV)	CORRECTION FACTOR (dB/m)
1	*5200.00	108.8 PK			1.49 H	328	70.4	38.4
2	*5200.00	100.6 AV			1.49 H	328	62.2	38.4
3	#10400.00	62.6 PK	68.2	-5.6	1.49 H	129	46.1	16.5

ANTENNA POLARITY & TEST DISTANCE: VERTICAL AT 3 M

NO.	FREQ. (MHz)	EMISSION LEVEL (dBuV/m)	LIMIT (dBuV/m)	MARGIN (dB)	ANTENNA HEIGHT (m)	TABLE ANGLE (Degree)	RAW VALUE (dBuV)	CORRECTION FACTOR (dB/m)
1	*5200.00	120.5 PK			1.43 V	148	82.1	38.4
2	*5200.00	112.1 AV			1.43 V	148	73.7	38.4
3	#10400.00	68.1 PK	68.2	-0.1	1.31 V	15	51.6	16.5

Remarks:

1. Emission Level(dBuV/m) = Raw Value(dBuV) + Correction Factor(dB/m).
2. Correction Factor(dB/m) = Antenna Factor(dB/m) + Cable Factor(dB) – Pre-Amplifier Factor(dB).
3. Margin value = Emission Level – Limit value.
4. The other emission levels were very low against the limit.
5. " * ": Fundamental frequency.
6. " # ": The radiated frequency is out of the restricted band.

CHANNEL	TX Channel 48	DETECTOR FUNCTION	Peak (PK) Average (AV)
FREQUENCY RANGE	1GHz ~ 40GHz		

ANTENNA POLARITY & TEST DISTANCE: HORIZONTAL AT 3 M

NO.	FREQ. (MHz)	EMISSION LEVEL (dBuV/m)	LIMIT (dBuV/m)	MARGIN (dB)	ANTENNA HEIGHT (m)	TABLE ANGLE (Degree)	RAW VALUE (dBuV)	CORRECTION FACTOR (dB/m)
1	*5240.00	108.5 PK			1.57 H	327	70.2	38.3
2	*5240.00	100.1 AV			1.57 H	327	61.8	38.3
3	5350.00	50.3 PK	74.0	-23.7	1.56 H	326	46.4	3.9
4	5350.00	38.4 AV	54.0	-15.6	1.56 H	326	34.5	3.9
5	#10480.00	62.6 PK	68.2	-5.6	1.43 H	132	46.3	16.3

ANTENNA POLARITY & TEST DISTANCE: VERTICAL AT 3 M

NO.	FREQ. (MHz)	EMISSION LEVEL (dBuV/m)	LIMIT (dBuV/m)	MARGIN (dB)	ANTENNA HEIGHT (m)	TABLE ANGLE (Degree)	RAW VALUE (dBuV)	CORRECTION FACTOR (dB/m)
1	*5240.00	119.4 PK			1.29 V	150	81.1	38.3
2	*5240.00	111.6 AV			1.29 V	150	73.3	38.3
3	5350.00	55.8 PK	74.0	-18.2	1.42 V	147	51.9	3.9
4	5350.00	42.7 AV	54.0	-11.3	1.42 V	147	38.8	3.9
5	#10480.00	67.8 PK	68.2	-0.4	1.23 V	23	51.5	16.3

Remarks:

1. Emission Level(dBuV/m) = Raw Value(dBuV) + Correction Factor(dB/m).
2. Correction Factor(dB/m) = Antenna Factor(dB/m) + Cable Factor(dB) – Pre-Amplifier Factor(dB).
3. Margin value = Emission Level – Limit value.
4. The other emission levels were very low against the limit.
5. " * " : Fundamental frequency.
6. " # " : The radiated frequency is out of the restricted band.

CHANNEL	TX Channel 149	DETECTOR FUNCTION	Peak (PK) Average (AV)
FREQUENCY RANGE	1GHz ~ 40GHz		

ANTENNA POLARITY & TEST DISTANCE: HORIZONTAL AT 3 M

NO.	FREQ. (MHz)	EMISSION LEVEL (dBuV/m)	LIMIT (dBuV/m)	MARGIN (dB)	ANTENNA HEIGHT (m)	TABLE ANGLE (Degree)	RAW VALUE (dBuV)	CORRECTION FACTOR (dB/m)
1	#5627.20	56.0 PK	68.2	-12.2	2.72 H	240	51.5	4.5
2	*5745.00	105.7 PK			2.72 H	240	66.7	39.0
3	*5745.00	95.9 AV			2.72 H	240	56.9	39.0
4	#5964.80	57.2 PK	68.2	-11.0	2.72 H	240	51.8	5.4
5	11490.00	61.0 PK	74.0	-13.0	1.00 H	360	44.2	16.8
6	11490.00	48.9 AV	54.0	-5.1	1.00 H	360	32.1	16.8

ANTENNA POLARITY & TEST DISTANCE: VERTICAL AT 3 M

NO.	FREQ. (MHz)	EMISSION LEVEL (dBuV/m)	LIMIT (dBuV/m)	MARGIN (dB)	ANTENNA HEIGHT (m)	TABLE ANGLE (Degree)	RAW VALUE (dBuV)	CORRECTION FACTOR (dB/m)
1	#5649.60	59.2 PK	68.2	-9.0	1.99 V	205	54.6	4.6
2	*5745.00	118.8 PK			1.99 V	205	79.8	39.0
3	*5745.00	108.7 AV			1.99 V	205	69.7	39.0
4	#5926.40	57.6 PK	68.2	-10.6	1.99 V	205	52.3	5.3
5	11490.00	67.7 PK	74.0	-6.3	1.00 V	299	50.9	16.8
6	11490.00	53.8 AV	54.0	-0.2	1.00 V	299	37.0	16.8

Remarks:

1. Emission Level(dBuV/m) = Raw Value(dBuV) + Correction Factor(dB/m).
2. Correction Factor(dB/m) = Antenna Factor(dB/m) + Cable Factor(dB) – Pre-Amplifier Factor(dB).
3. Margin value = Emission Level – Limit value.
4. The other emission levels were very low against the limit.
5. " * " : Fundamental frequency.
6. " # " : The radiated frequency is out of the restricted band.

CHANNEL	TX Channel 157	DETECTOR FUNCTION	Peak (PK) Average (AV)
FREQUENCY RANGE	1GHz ~ 40GHz		

ANTENNA POLARITY & TEST DISTANCE: HORIZONTAL AT 3 M

NO.	FREQ. (MHz)	EMISSION LEVEL (dBuV/m)	LIMIT (dBuV/m)	MARGIN (dB)	ANTENNA HEIGHT (m)	TABLE ANGLE (Degree)	RAW VALUE (dBuV)	CORRECTION FACTOR (dB/m)
1	#5649.60	56.1 PK	68.2	-12.1	2.73 H	243	51.5	4.6
2	*5785.00	103.4 PK			2.73 H	243	64.2	39.2
3	*5785.00	93.8 AV			2.73 H	243	54.6	39.2
4	#5980.00	56.6 PK	68.2	-11.6	2.73 H	243	51.3	5.3
5	11570.00	56.1 PK	74.0	-17.9	1.07 H	315	39.5	16.6
6	11570.00	43.2 AV	54.0	-10.8	1.07 H	315	26.6	16.6

ANTENNA POLARITY & TEST DISTANCE: VERTICAL AT 3 M

NO.	FREQ. (MHz)	EMISSION LEVEL (dBuV/m)	LIMIT (dBuV/m)	MARGIN (dB)	ANTENNA HEIGHT (m)	TABLE ANGLE (Degree)	RAW VALUE (dBuV)	CORRECTION FACTOR (dB/m)
1	#5628.80	56.8 PK	68.2	-11.4	2.02 V	237	52.3	4.5
2	*5785.00	115.9 PK			2.02 V	237	76.7	39.2
3	*5785.00	106.6 AV			2.02 V	237	67.4	39.2
4	#5946.40	56.8 PK	68.2	-11.4	2.02 V	237	51.5	5.3
5	11570.00	67.7 PK	74.0	-6.3	1.06 V	303	51.1	16.6
6	11570.00	53.4 AV	54.0	-0.6	1.06 V	303	36.8	16.6

Remarks:

1. Emission Level(dBuV/m) = Raw Value(dBuV) + Correction Factor(dB/m).
2. Correction Factor(dB/m) = Antenna Factor(dB/m) + Cable Factor(dB) – Pre-Amplifier Factor(dB).
3. Margin value = Emission Level – Limit value.
4. The other emission levels were very low against the limit.
5. " * " : Fundamental frequency.
6. " # " : The radiated frequency is out of the restricted band.

CHANNEL	TX Channel 165	DETECTOR FUNCTION	Peak (PK) Average (AV)
FREQUENCY RANGE	1GHz ~ 40GHz		

ANTENNA POLARITY & TEST DISTANCE: HORIZONTAL AT 3 M								
NO.	FREQ. (MHz)	EMISSION LEVEL (dBuV/m)	LIMIT (dBuV/m)	MARGIN (dB)	ANTENNA HEIGHT (m)	TABLE ANGLE (Degree)	RAW VALUE (dBuV)	CORRECTION FACTOR (dB/m)
1	#5609.60	55.2 PK	68.2	-13.0	2.77 H	240	50.8	4.4
2	*5825.00	105.1 PK			2.77 H	240	65.7	39.4
3	*5825.00	95.4 AV			2.77 H	240	56.0	39.4
4	#5944.80	56.5 PK	68.2	-11.7	2.77 H	240	51.2	5.3
5	11650.00	59.3 PK	74.0	-14.7	1.07 H	319	42.8	16.5
6	11650.00	47.7 AV	54.0	-6.3	1.07 H	319	31.2	16.5

ANTENNA POLARITY & TEST DISTANCE: VERTICAL AT 3 M								
NO.	FREQ. (MHz)	EMISSION LEVEL (dBuV/m)	LIMIT (dBuV/m)	MARGIN (dB)	ANTENNA HEIGHT (m)	TABLE ANGLE (Degree)	RAW VALUE (dBuV)	CORRECTION FACTOR (dB/m)
1	#5638.40	55.2 PK	68.2	-13.0	1.89 V	205	50.6	4.6
2	*5825.00	117.7 PK			1.89 V	205	78.3	39.4
3	*5825.00	107.9 AV			1.89 V	205	68.5	39.4
4	#5988.80	56.7 PK	68.2	-11.5	1.89 V	205	51.4	5.3
5	11650.00	66.2 PK	74.0	-7.8	1.05 V	297	49.7	16.5
6	11650.00	52.4 AV	54.0	-1.6	1.05 V	297	35.9	16.5

Remarks:

1. Emission Level(dBuV/m) = Raw Value(dBuV) + Correction Factor(dB/m).
2. Correction Factor(dB/m) = Antenna Factor(dB/m) + Cable Factor(dB) – Pre-Amplifier Factor(dB).
3. Margin value = Emission Level – Limit value.
4. The other emission levels were very low against the limit.
5. " * " : Fundamental frequency.
6. " # " : The radiated frequency is out of the restricted band.

802.11ax (HE20)

CHANNEL	TX Channel 36	DETECTOR FUNCTION	Peak (PK) Average (AV)
FREQUENCY RANGE	1GHz ~ 40GHz		

ANTENNA POLARITY & TEST DISTANCE: HORIZONTAL AT 3 M								
NO.	FREQ. (MHz)	EMISSION LEVEL (dBuV/m)	LIMIT (dBuV/m)	MARGIN (dB)	ANTENNA HEIGHT (m)	TABLE ANGLE (Degree)	RAW VALUE (dBuV)	CORRECTION FACTOR (dB/m)
1	5150.00	61.3 PK	74.0	-12.7	1.55 H	325	57.2	4.1
2	5150.00	42.5 AV	54.0	-11.5	1.55 H	325	38.4	4.1
3	*5180.00	108.7 PK			1.49 H	326	70.2	38.5
4	*5180.00	96.7 AV			1.49 H	326	58.2	38.5
5	#10360.00	62.5 PK	68.2	-5.7	1.42 H	139	46.0	16.5

ANTENNA POLARITY & TEST DISTANCE: VERTICAL AT 3 M								
NO.	FREQ. (MHz)	EMISSION LEVEL (dBuV/m)	LIMIT (dBuV/m)	MARGIN (dB)	ANTENNA HEIGHT (m)	TABLE ANGLE (Degree)	RAW VALUE (dBuV)	CORRECTION FACTOR (dB/m)
1	5150.00	72.9 PK	74.0	-1.1	1.29 V	146	68.8	4.1
2	5150.00	53.3 AV	54.0	-0.7	1.29 V	146	49.2	4.1
3	*5180.00	119.4 PK			1.37 V	145	80.9	38.5
4	*5180.00	108.6 AV			1.37 V	145	70.1	38.5
5	#10360.00	66.8 PK	68.2	-1.4	1.37 V	19	50.3	16.5

Remarks:

1. Emission Level(dBuV/m) = Raw Value(dBuV) + Correction Factor(dB/m).
2. Correction Factor(dB/m) = Antenna Factor(dB/m) + Cable Factor(dB) – Pre-Amplifier Factor(dB).
3. Margin value = Emission Level – Limit value.
4. The other emission levels were very low against the limit.
5. " * ": Fundamental frequency.
6. " # ": The radiated frequency is out of the restricted band.

CHANNEL	TX Channel 40	DETECTOR FUNCTION	Peak (PK) Average (AV)
FREQUENCY RANGE	1GHz ~ 40GHz		

ANTENNA POLARITY & TEST DISTANCE: HORIZONTAL AT 3 M

NO.	FREQ. (MHz)	EMISSION LEVEL (dBuV/m)	LIMIT (dBuV/m)	MARGIN (dB)	ANTENNA HEIGHT (m)	TABLE ANGLE (Degree)	RAW VALUE (dBuV)	CORRECTION FACTOR (dB/m)
1	*5200.00	110.3 PK			1.48 H	325	71.9	38.4
2	*5200.00	100.3 AV			1.48 H	325	61.9	38.4
3	#10400.00	62.2 PK	68.2	-6.0	1.34 H	141	45.7	16.5

ANTENNA POLARITY & TEST DISTANCE: VERTICAL AT 3 M

NO.	FREQ. (MHz)	EMISSION LEVEL (dBuV/m)	LIMIT (dBuV/m)	MARGIN (dB)	ANTENNA HEIGHT (m)	TABLE ANGLE (Degree)	RAW VALUE (dBuV)	CORRECTION FACTOR (dB/m)
1	*5200.00	121.6 PK			1.42 V	150	83.2	38.4
2	*5200.00	111.5 AV			1.42 V	150	73.1	38.4
3	#10400.00	67.0 PK	68.2	-1.2	1.39 V	10	50.5	16.5

Remarks:

1. Emission Level(dBuV/m) = Raw Value(dBuV) + Correction Factor(dB/m).
2. Correction Factor(dB/m) = Antenna Factor(dB/m) + Cable Factor(dB) – Pre-Amplifier Factor(dB).
3. Margin value = Emission Level – Limit value.
4. The other emission levels were very low against the limit.
5. " * ": Fundamental frequency.
6. " # ": The radiated frequency is out of the restricted band.

CHANNEL	TX Channel 48	DETECTOR FUNCTION	Peak (PK) Average (AV)
FREQUENCY RANGE	1GHz ~ 40GHz		

ANTENNA POLARITY & TEST DISTANCE: HORIZONTAL AT 3 M

NO.	FREQ. (MHz)	EMISSION LEVEL (dBuV/m)	LIMIT (dBuV/m)	MARGIN (dB)	ANTENNA HEIGHT (m)	TABLE ANGLE (Degree)	RAW VALUE (dBuV)	CORRECTION FACTOR (dB/m)
1	*5240.00	109.9 PK			1.48 H	324	71.6	38.3
2	*5240.00	100.0 AV			1.48 H	324	61.7	38.3
3	5350.00	53.2 PK	74.0	-20.8	1.55 H	325	49.3	3.9
4	5350.00	39.8 AV	54.0	-14.2	1.55 H	325	35.9	3.9
5	#10480.00	62.8 PK	68.2	-5.4	1.52 H	143	46.5	16.3

ANTENNA POLARITY & TEST DISTANCE: VERTICAL AT 3 M

NO.	FREQ. (MHz)	EMISSION LEVEL (dBuV/m)	LIMIT (dBuV/m)	MARGIN (dB)	ANTENNA HEIGHT (m)	TABLE ANGLE (Degree)	RAW VALUE (dBuV)	CORRECTION FACTOR (dB/m)
1	*5240.00	121.3 PK			1.42 V	146	83.0	38.3
2	*5240.00	111.1 AV			1.42 V	146	72.8	38.3
3	5350.00	52.8 PK	74.0	-21.2	1.30 V	148	48.9	3.9
4	5350.00	39.9 AV	54.0	-14.1	1.30 V	148	36.0	3.9
5	#10480.00	66.9 PK	68.2	-1.3	1.24 V	16	50.6	16.3

Remarks:

1. Emission Level(dBuV/m) = Raw Value(dBuV) + Correction Factor(dB/m).
2. Correction Factor(dB/m) = Antenna Factor(dB/m) + Cable Factor(dB) – Pre-Amplifier Factor(dB).
3. Margin value = Emission Level – Limit value.
4. The other emission levels were very low against the limit.
5. " * " : Fundamental frequency.
6. " # " : The radiated frequency is out of the restricted band.

CHANNEL	TX Channel 149	DETECTOR FUNCTION	Peak (PK) Average (AV)
FREQUENCY RANGE	1GHz ~ 40GHz		

ANTENNA POLARITY & TEST DISTANCE: HORIZONTAL AT 3 M

NO.	FREQ. (MHz)	EMISSION LEVEL (dBuV/m)	LIMIT (dBuV/m)	MARGIN (dB)	ANTENNA HEIGHT (m)	TABLE ANGLE (Degree)	RAW VALUE (dBuV)	CORRECTION FACTOR (dB/m)
1	#5617.60	56.1 PK	68.2	-12.1	2.78 H	242	51.6	4.5
2	*5745.00	108.3 PK			2.78 H	242	69.3	39.0
3	*5745.00	95.9 AV			2.78 H	242	56.9	39.0
4	#5972.00	57.2 PK	68.2	-11.0	2.78 H	242	51.9	5.3
5	11490.00	61.0 PK	74.0	-13.0	1.08 H	328	44.2	16.8
6	11490.00	49.2 AV	54.0	-4.8	1.08 H	328	32.4	16.8

ANTENNA POLARITY & TEST DISTANCE: VERTICAL AT 3 M

NO.	FREQ. (MHz)	EMISSION LEVEL (dBuV/m)	LIMIT (dBuV/m)	MARGIN (dB)	ANTENNA HEIGHT (m)	TABLE ANGLE (Degree)	RAW VALUE (dBuV)	CORRECTION FACTOR (dB/m)
1	#5640.80	57.1 PK	68.2	-11.1	1.98 V	208	52.5	4.6
2	*5745.00	121.1 PK			1.98 V	208	82.1	39.0
3	*5745.00	108.9 AV			1.98 V	208	69.9	39.0
4	#5953.60	56.1 PK	68.2	-12.1	1.98 V	208	50.8	5.3
5	11490.00	67.3 PK	74.0	-6.7	1.00 V	299	50.5	16.8
6	11490.00	53.8 AV	54.0	-0.2	1.00 V	299	37.0	16.8

Remarks:

1. Emission Level(dBuV/m) = Raw Value(dBuV) + Correction Factor(dB/m).
2. Correction Factor(dB/m) = Antenna Factor(dB/m) + Cable Factor(dB) – Pre-Amplifier Factor(dB).
3. Margin value = Emission Level – Limit value.
4. The other emission levels were very low against the limit.
5. " * " : Fundamental frequency.
6. " # " : The radiated frequency is out of the restricted band.

CHANNEL	TX Channel 157	DETECTOR FUNCTION	Peak (PK) Average (AV)
FREQUENCY RANGE	1GHz ~ 40GHz		

ANTENNA POLARITY & TEST DISTANCE: HORIZONTAL AT 3 M

NO.	FREQ. (MHz)	EMISSION LEVEL (dBuV/m)	LIMIT (dBuV/m)	MARGIN (dB)	ANTENNA HEIGHT (m)	TABLE ANGLE (Degree)	RAW VALUE (dBuV)	CORRECTION FACTOR (dB/m)
1	#5624.80	55.6 PK	68.2	-12.6	2.77 H	242	51.1	4.5
2	*5785.00	109.1 PK			2.77 H	242	69.9	39.2
3	*5785.00	96.7 AV			2.77 H	242	57.5	39.2
4	#5984.80	56.8 PK	68.2	-11.4	2.77 H	242	51.5	5.3
5	11570.00	60.8 PK	74.0	-13.2	1.17 H	327	44.2	16.6
6	11570.00	49.0 AV	54.0	-5.0	1.17 H	327	32.4	16.6

ANTENNA POLARITY & TEST DISTANCE: VERTICAL AT 3 M

NO.	FREQ. (MHz)	EMISSION LEVEL (dBuV/m)	LIMIT (dBuV/m)	MARGIN (dB)	ANTENNA HEIGHT (m)	TABLE ANGLE (Degree)	RAW VALUE (dBuV)	CORRECTION FACTOR (dB/m)
1	#5648.00	57.1 PK	68.2	-11.1	1.94 V	191	52.5	4.6
2	*5785.00	122.0 PK			1.94 V	191	82.8	39.2
3	*5785.00	109.2 AV			1.94 V	191	70.0	39.2
4	#5993.60	57.7 PK	68.2	-10.5	1.94 V	191	52.4	5.3
5	11570.00	67.0 PK	74.0	-7.0	1.11 V	291	50.4	16.6
6	11570.00	53.4 AV	54.0	-0.6	1.11 V	291	36.8	16.6

Remarks:

1. Emission Level(dBuV/m) = Raw Value(dBuV) + Correction Factor(dB/m).
2. Correction Factor(dB/m) = Antenna Factor(dB/m) + Cable Factor(dB) – Pre-Amplifier Factor(dB).
3. Margin value = Emission Level – Limit value.
4. The other emission levels were very low against the limit.
5. " * " : Fundamental frequency.
6. " # " : The radiated frequency is out of the restricted band.

CHANNEL	TX Channel 165	DETECTOR FUNCTION	Peak (PK) Average (AV)
FREQUENCY RANGE	1GHz ~ 40GHz		

ANTENNA POLARITY & TEST DISTANCE: HORIZONTAL AT 3 M

NO.	FREQ. (MHz)	EMISSION LEVEL (dBuV/m)	LIMIT (dBuV/m)	MARGIN (dB)	ANTENNA HEIGHT (m)	TABLE ANGLE (Degree)	RAW VALUE (dBuV)	CORRECTION FACTOR (dB/m)
1	#5647.20	56.2 PK	68.2	-12.0	2.79 H	239	51.6	4.6
2	*5825.00	108.7 PK			2.79 H	239	69.3	39.4
3	*5825.00	96.7 AV			2.79 H	239	57.3	39.4
4	#5973.60	56.9 PK	68.2	-11.3	2.79 H	239	51.6	5.3
5	11650.00	59.9 PK	74.0	-14.1	1.11 H	319	43.4	16.5
6	11650.00	47.5 AV	54.0	-6.5	1.11 H	319	31.0	16.5

ANTENNA POLARITY & TEST DISTANCE: VERTICAL AT 3 M

NO.	FREQ. (MHz)	EMISSION LEVEL (dBuV/m)	LIMIT (dBuV/m)	MARGIN (dB)	ANTENNA HEIGHT (m)	TABLE ANGLE (Degree)	RAW VALUE (dBuV)	CORRECTION FACTOR (dB/m)
1	#5647.20	56.5 PK	68.2	-11.7	1.91 V	199	51.9	4.6
2	*5825.00	121.3 PK			1.91 V	199	81.9	39.4
3	*5825.00	109.4 AV			1.91 V	199	70.0	39.4
4	#5925.00	59.7 PK	68.2	-8.5	1.91 V	199	54.4	5.3
5	11650.00	66.1 PK	74.0	-7.9	1.18 V	294	49.6	16.5
6	11650.00	52.7 AV	54.0	-1.3	1.18 V	294	36.2	16.5

Remarks:

1. Emission Level(dBuV/m) = Raw Value(dBuV) + Correction Factor(dB/m).
2. Correction Factor(dB/m) = Antenna Factor(dB/m) + Cable Factor(dB) – Pre-Amplifier Factor(dB).
3. Margin value = Emission Level – Limit value.
4. The other emission levels were very low against the limit.
5. " * " : Fundamental frequency.
6. " # " : The radiated frequency is out of the restricted band.

802.11ax (HE40)

CHANNEL	TX Channel 38	DETECTOR FUNCTION	Peak (PK) Average (AV)
FREQUENCY RANGE	1GHz ~ 40GHz		

ANTENNA POLARITY & TEST DISTANCE: HORIZONTAL AT 3 M								
NO.	FREQ. (MHz)	EMISSION LEVEL (dBuV/m)	LIMIT (dBuV/m)	MARGIN (dB)	ANTENNA HEIGHT (m)	TABLE ANGLE (Degree)	RAW VALUE (dBuV)	CORRECTION FACTOR (dB/m)
1	5150.00	55.7 PK	74.0	-18.3	1.47 H	329	51.6	4.1
2	5150.00	39.6 AV	54.0	-14.4	1.47 H	329	35.5	4.1
3	*5190.00	101.7 PK			1.48 H	327	63.3	38.4
4	*5190.00	92.7 AV			1.48 H	327	54.3	38.4
5	#10380.00	56.1 PK	68.2	-12.1	1.49 H	137	39.5	16.6

ANTENNA POLARITY & TEST DISTANCE: VERTICAL AT 3 M								
NO.	FREQ. (MHz)	EMISSION LEVEL (dBuV/m)	LIMIT (dBuV/m)	MARGIN (dB)	ANTENNA HEIGHT (m)	TABLE ANGLE (Degree)	RAW VALUE (dBuV)	CORRECTION FACTOR (dB/m)
1	5150.00	71.1 PK	74.0	-2.9	1.31 V	149	67.0	4.1
2	5150.00	53.5 AV	54.0	-0.5	1.31 V	149	49.4	4.1
3	*5190.00	112.4 PK			1.29 V	147	74.0	38.4
4	*5190.00	103.6 AV			1.29 V	147	65.2	38.4
5	#10380.00	60.2 PK	68.2	-8.0	1.24 V	8	43.6	16.6

Remarks:

1. Emission Level(dBuV/m) = Raw Value(dBuV) + Correction Factor(dB/m).
2. Correction Factor(dB/m) = Antenna Factor(dB/m) + Cable Factor(dB) – Pre-Amplifier Factor(dB).
3. Margin value = Emission Level – Limit value.
4. The other emission levels were very low against the limit.
5. " * ": Fundamental frequency.
6. " # ": The radiated frequency is out of the restricted band.

CHANNEL	TX Channel 46	DETECTOR FUNCTION	Peak (PK) Average (AV)
FREQUENCY RANGE	1GHz ~ 40GHz		

ANTENNA POLARITY & TEST DISTANCE: HORIZONTAL AT 3 M

NO.	FREQ. (MHz)	EMISSION LEVEL (dBuV/m)	LIMIT (dBuV/m)	MARGIN (dB)	ANTENNA HEIGHT (m)	TABLE ANGLE (Degree)	RAW VALUE (dBuV)	CORRECTION FACTOR (dB/m)
1	5150.00	55.8 PK	74.0	-18.2	1.49 H	325	51.7	4.1
2	5150.00	42.6 AV	54.0	-11.4	1.49 H	325	38.5	4.1
3	*5230.00	106.2 PK			1.55 H	325	68.0	38.2
4	*5230.00	96.5 AV			1.55 H	325	58.3	38.2
5	5350.00	53.0 PK	74.0	-21.0	1.47 H	149	49.1	3.9
6	5350.00	40.8 AV	54.0	-13.2	1.47 H	149	36.9	3.9
7	#10460.00	63.9 PK	68.2	-4.3	1.37 H	11	47.6	16.3

ANTENNA POLARITY & TEST DISTANCE: VERTICAL AT 3 M

NO.	FREQ. (MHz)	EMISSION LEVEL (dBuV/m)	LIMIT (dBuV/m)	MARGIN (dB)	ANTENNA HEIGHT (m)	TABLE ANGLE (Degree)	RAW VALUE (dBuV)	CORRECTION FACTOR (dB/m)
1	5150.00	69.6 PK	74.0	-4.4	1.34 V	147	65.5	4.1
2	5150.00	53.9 AV	54.0	-0.1	1.34 V	147	49.8	4.1
3	*5230.00	117.8 PK			1.42 V	147	79.6	38.2
4	*5230.00	107.6 AV			1.42 V	147	69.4	38.2
5	5350.00	55.2 PK	74.0	-18.8	1.39 V	149	51.3	3.9
6	5350.00	41.7 AV	54.0	-12.3	1.39 V	149	37.8	3.9
7	#10460.00	63.9 PK	68.2	-4.3	1.37 V	11	47.6	16.3

Remarks:

1. Emission Level(dBuV/m) = Raw Value(dBuV) + Correction Factor(dB/m).
2. Correction Factor(dB/m) = Antenna Factor(dB/m) + Cable Factor(dB) – Pre-Amplifier Factor(dB).
3. Margin value = Emission Level – Limit value.
4. The other emission levels were very low against the limit.
5. " * ": Fundamental frequency.
6. " # ": The radiated frequency is out of the restricted band.

CHANNEL	TX Channel 151	DETECTOR FUNCTION	Peak (PK) Average (AV)
FREQUENCY RANGE	1GHz ~ 40GHz		

ANTENNA POLARITY & TEST DISTANCE: HORIZONTAL AT 3 M

NO.	FREQ. (MHz)	EMISSION LEVEL (dBuV/m)	LIMIT (dBuV/m)	MARGIN (dB)	ANTENNA HEIGHT (m)	TABLE ANGLE (Degree)	RAW VALUE (dBuV)	CORRECTION FACTOR (dB/m)
1	#5646.40	59.3 PK	68.2	-8.9	2.72 H	238	54.7	4.6
2	*5755.00	106.5 PK			2.72 H	238	67.4	39.1
3	*5755.00	93.2 AV			2.72 H	238	54.1	39.1
4	#5973.60	55.9 PK	68.2	-12.3	2.72 H	238	50.6	5.3
5	11510.00	58.0 PK	74.0	-16.0	1.06 H	325	41.2	16.8
6	11510.00	46.0 AV	54.0	-8.0	1.06 H	325	29.2	16.8

ANTENNA POLARITY & TEST DISTANCE: VERTICAL AT 3 M

NO.	FREQ. (MHz)	EMISSION LEVEL (dBuV/m)	LIMIT (dBuV/m)	MARGIN (dB)	ANTENNA HEIGHT (m)	TABLE ANGLE (Degree)	RAW VALUE (dBuV)	CORRECTION FACTOR (dB/m)
1	#5648.00	67.9 PK	68.2	-0.3	1.85 V	206	63.3	4.6
2	#5652.00	69.1 PK	69.7	-0.6	1.85 V	206	64.5	4.6
3	*5755.00	119.4 PK			1.85 V	206	80.3	39.1
4	*5755.00	105.8 AV			1.85 V	206	66.7	39.1
5	#5939.20	62.0 PK	68.2	-6.2	1.85 V	206	56.7	5.3
6	11510.00	61.9 PK	74.0	-12.1	1.17 V	303	45.1	16.8
7	11510.00	47.8 AV	54.0	-6.2	1.17 V	303	31.0	16.8

Remarks:

1. Emission Level(dBuV/m) = Raw Value(dBuV) + Correction Factor(dB/m).
2. Correction Factor(dB/m) = Antenna Factor(dB/m) + Cable Factor(dB) – Pre-Amplifier Factor(dB).
3. Margin value = Emission Level – Limit value.
4. The other emission levels were very low against the limit.
5. " * ": Fundamental frequency.
6. " # ": The radiated frequency is out of the restricted band.

CHANNEL	TX Channel 159	DETECTOR FUNCTION	Peak (PK) Average (AV)
FREQUENCY RANGE	1GHz ~ 40GHz		

ANTENNA POLARITY & TEST DISTANCE: HORIZONTAL AT 3 M

NO.	FREQ. (MHz)	EMISSION LEVEL (dBuV/m)	LIMIT (dBuV/m)	MARGIN (dB)	ANTENNA HEIGHT (m)	TABLE ANGLE (Degree)	RAW VALUE (dBuV)	CORRECTION FACTOR (dB/m)
1	#5622.40	55.3 PK	68.2	-12.9	2.82 H	240	50.8	4.5
2	*5795.00	104.7 PK			2.82 H	240	65.5	39.2
3	*5795.00	92.7 AV			2.82 H	240	53.5	39.2
4	#5927.20	56.5 PK	68.2	-11.7	2.82 H	240	51.2	5.3
5	11590.00	57.1 PK	74.0	-16.9	1.14 H	315	40.6	16.5
6	11590.00	43.9 AV	54.0	-10.1	1.14 H	315	27.4	16.5

ANTENNA POLARITY & TEST DISTANCE: VERTICAL AT 3 M

NO.	FREQ. (MHz)	EMISSION LEVEL (dBuV/m)	LIMIT (dBuV/m)	MARGIN (dB)	ANTENNA HEIGHT (m)	TABLE ANGLE (Degree)	RAW VALUE (dBuV)	CORRECTION FACTOR (dB/m)
1	#5632.80	58.3 PK	68.2	-9.9	1.97 V	198	53.7	4.6
2	*5795.00	117.5 PK			1.97 V	198	78.3	39.2
3	*5795.00	105.2 AV			1.97 V	198	66.0	39.2
4	#5925.00	64.7 PK	68.2	-3.5	1.97 V	198	59.4	5.3
5	11590.00	61.4 PK	74.0	-12.6	1.13 V	306	44.9	16.5
6	11590.00	47.5 AV	54.0	-6.5	1.13 V	306	31.0	16.5

Remarks:

1. Emission Level(dBuV/m) = Raw Value(dBuV) + Correction Factor(dB/m).
2. Correction Factor(dB/m) = Antenna Factor(dB/m) + Cable Factor(dB) – Pre-Amplifier Factor(dB).
3. Margin value = Emission Level – Limit value.
4. The other emission levels were very low against the limit.
5. " * " : Fundamental frequency.
6. " # " : The radiated frequency is out of the restricted band.

802.11ax (HE80)

CHANNEL	TX Channel 42	DETECTOR FUNCTION	Peak (PK) Average (AV)
FREQUENCY RANGE	1GHz ~ 40GHz		

ANTENNA POLARITY & TEST DISTANCE: HORIZONTAL AT 3 M

NO.	FREQ. (MHz)	EMISSION LEVEL (dBuV/m)	LIMIT (dBuV/m)	MARGIN (dB)	ANTENNA HEIGHT (m)	TABLE ANGLE (Degree)	RAW VALUE (dBuV)	CORRECTION FACTOR (dB/m)
1	5150.00	55.4 PK	74.0	-18.6	1.54 H	326	51.3	4.1
2	5150.00	42.5 AV	54.0	-11.5	1.54 H	326	38.4	4.1
3	*5210.00	96.4 PK			1.53 H	326	58.1	38.3
4	*5210.00	87.2 AV			1.53 H	326	48.9	38.3
5	5350.00	53.8 PK	74.0	-20.2	1.52 H	328	49.9	3.9
6	5350.00	41.9 AV	54.0	-12.1	1.52 H	328	38.0	3.9
7	#10420.00	57.1 PK	68.2	-11.1	1.49 H	145	40.6	16.5

ANTENNA POLARITY & TEST DISTANCE: VERTICAL AT 3 M

NO.	FREQ. (MHz)	EMISSION LEVEL (dBuV/m)	LIMIT (dBuV/m)	MARGIN (dB)	ANTENNA HEIGHT (m)	TABLE ANGLE (Degree)	RAW VALUE (dBuV)	CORRECTION FACTOR (dB/m)
1	5150.00	67.2 PK	74.0	-6.8	1.39 V	147	63.1	4.1
2	5150.00	53.6 AV	54.0	-0.4	1.39 V	147	49.5	4.1
3	*5210.00	107.7 PK			1.42 V	147	69.4	38.3
4	*5210.00	98.8 AV			1.42 V	147	60.5	38.3
5	5350.00	54.2 PK	74.0	-19.8	1.33 V	148	50.3	3.9
6	5350.00	42.5 AV	54.0	-11.5	1.33 V	148	38.6	3.9
7	#10420.00	57.5 PK	68.2	-10.7	1.24 V	12	41.0	16.5

Remarks:

1. Emission Level(dBuV/m) = Raw Value(dBuV) + Correction Factor(dB/m).
2. Correction Factor(dB/m) = Antenna Factor(dB/m) + Cable Factor(dB) – Pre-Amplifier Factor(dB).
3. Margin value = Emission Level – Limit value.
4. The other emission levels were very low against the limit.
5. " * ": Fundamental frequency.
6. " # ": The radiated frequency is out of the restricted band.

CHANNEL	TX Channel 155	DETECTOR FUNCTION	Peak (PK) Average (AV)
FREQUENCY RANGE	1GHz ~ 40GHz		

ANTENNA POLARITY & TEST DISTANCE: HORIZONTAL AT 3 M

NO.	FREQ. (MHz)	EMISSION LEVEL (dBuV/m)	LIMIT (dBuV/m)	MARGIN (dB)	ANTENNA HEIGHT (m)	TABLE ANGLE (Degree)	RAW VALUE (dBuV)	CORRECTION FACTOR (dB/m)
1	#5643.20	58.5 PK	68.2	-9.7	2.81 H	242	53.9	4.6
2	*5775.00	100.3 PK			2.81 H	242	61.2	39.1
3	*5775.00	88.4 AV			2.81 H	242	49.3	39.1
4	#5941.60	57.5 PK	68.2	-10.7	2.81 H	242	52.2	5.3
5	11550.00	56.3 PK	74.0	-17.7	1.00 H	315	39.6	16.7
6	11550.00	43.4 AV	54.0	-10.6	1.00 H	315	26.7	16.7

ANTENNA POLARITY & TEST DISTANCE: VERTICAL AT 3 M

NO.	FREQ. (MHz)	EMISSION LEVEL (dBuV/m)	LIMIT (dBuV/m)	MARGIN (dB)	ANTENNA HEIGHT (m)	TABLE ANGLE (Degree)	RAW VALUE (dBuV)	CORRECTION FACTOR (dB/m)
1	#5649.60	67.8 PK	68.2	-0.4	1.91 V	208	63.2	4.6
2	#5650.40	68.4 PK	68.5	-0.1	1.91 V	208	63.8	4.6
3	*5775.00	112.9 PK			1.91 V	208	73.8	39.1
4	*5775.00	101.4 AV			1.91 V	208	62.3	39.1
5	#5928.80	66.0 PK	68.2	-2.2	1.91 V	208	60.7	5.3
6	11550.00	59.6 PK	74.0	-14.4	1.13 V	306	42.9	16.7
7	11550.00	45.7 AV	54.0	-8.3	1.13 V	306	29.0	16.7

Remarks:

1. Emission Level(dBuV/m) = Raw Value(dBuV) + Correction Factor(dB/m).
2. Correction Factor(dB/m) = Antenna Factor(dB/m) + Cable Factor(dB) – Pre-Amplifier Factor(dB).
3. Margin value = Emission Level – Limit value.
4. The other emission levels were very low against the limit.
5. " * ": Fundamental frequency.
6. " # ": The radiated frequency is out of the restricted band.

Below 1GHz Worst-Case Data:

802.11a

CHANNEL	TX Channel 157	DETECTOR FUNCTION	Quasi-Peak (QP)
FREQUENCY RANGE	9kHz ~ 1GHz		
TEST MODE	A		

ANTENNA POLARITY & TEST DISTANCE: HORIZONTAL AT 3 M								
NO.	FREQ. (MHz)	EMISSION LEVEL (dBuV/m)	LIMIT (dBuV/m)	MARGIN (dB)	ANTENNA HEIGHT (m)	TABLE ANGLE (Degree)	RAW VALUE (dBuV)	CORRECTION FACTOR (dB/m)
1	31.94	35.4 QP	40.0	-4.6	1.00 H	38	46.6	-11.2
2	50.37	37.0 QP	40.0	-3.0	1.50 H	92	46.8	-9.8
3	101.78	28.9 QP	43.5	-14.6	1.00 H	204	42.3	-13.4
4	159.01	30.5 QP	43.5	-13.0	1.00 H	69	39.5	-9.0
5	275.41	40.1 QP	46.0	-5.9	1.00 H	69	48.7	-8.6
6	500.45	40.7 QP	46.0	-5.3	1.00 H	13	44.6	-3.9

Remarks:

1. Emission Level(dBuV/m) = Raw Value(dBuV) + Correction Factor(dB/m).
2. Correction Factor(dB/m) = Antenna Factor(dB/m) + Cable Factor(dB) – Pre-Amplifier Factor(dB).
3. The other emission levels were very low against the limit of frequency range 30MHz ~ 1000MHz.
4. Margin value = Emission Level – Limit value.
5. The emission levels were very low against the limit of frequency range 9kHz ~ 30MHz: the amplitude of spurious emissions attenuated more than 20 dB below the permissible value to be report.

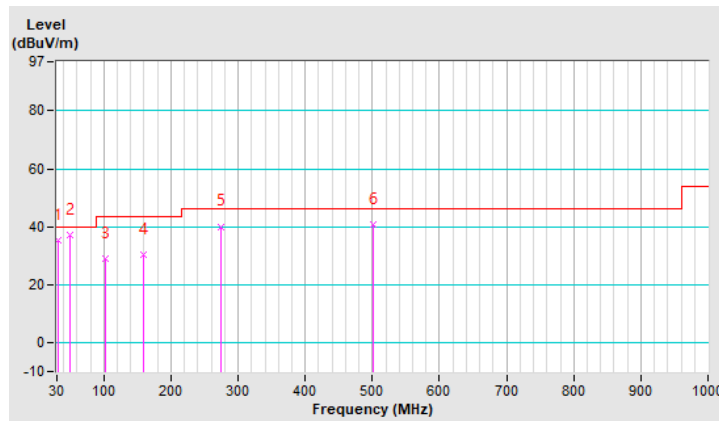

CHANNEL	TX Channel 157	DETECTOR FUNCTION	Quasi-Peak (QP)
FREQUENCY RANGE	9kHz ~ 1GHz		
TEST MODE	A		

ANTENNA POLARITY & TEST DISTANCE: VERTICAL AT 3 M								
NO.	FREQ. (MHz)	EMISSION LEVEL (dBuV/m)	LIMIT (dBuV/m)	MARGIN (dB)	ANTENNA HEIGHT (m)	TABLE ANGLE (Degree)	RAW VALUE (dBuV)	CORRECTION FACTOR (dB/m)
1	75.59	25.6 QP	40.0	-14.4	1.01 V	220	38.6	-13.0
2	168.71	29.8 QP	43.5	-13.7	1.50 V	67	39.1	-9.3
3	206.54	27.4 QP	43.5	-16.1	1.01 V	14	39.0	-11.6
4	250.19	34.2 QP	46.0	-11.8	1.01 V	124	44.0	-9.8
5	448.07	36.3 QP	46.0	-9.7	1.01 V	227	40.8	-4.5
6	500.45	40.1 QP	46.0	-5.9	1.50 V	36	44.0	-3.9

Remarks:

1. Emission Level(dBuV/m) = Raw Value(dBuV) + Correction Factor(dB/m).
2. Correction Factor(dB/m) = Antenna Factor(dB/m) + Cable Factor(dB) – Pre-Amplifier Factor(dB).
3. The other emission levels were very low against the limit of frequency range 30MHz ~ 1000MHz.
4. Margin value = Emission Level – Limit value.
5. The emission levels were very low against the limit of frequency range 9kHz ~ 30MHz: the amplitude of spurious emissions attenuated more than 20 dB below the permissible value to be report.

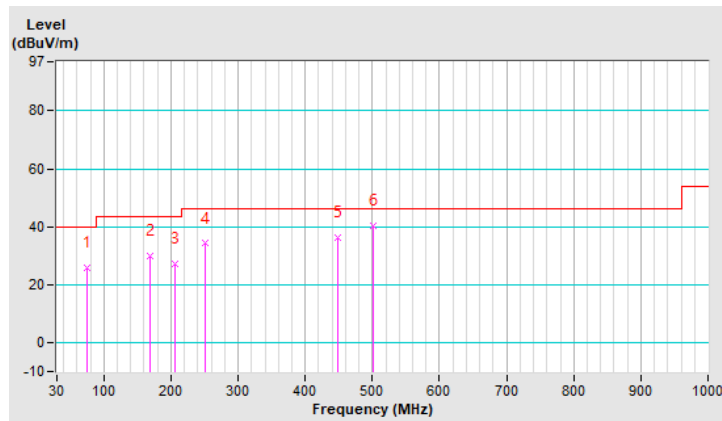

CHANNEL	TX Channel 157	DETECTOR FUNCTION	Quasi-Peak (QP)
FREQUENCY RANGE	9kHz ~ 1GHz		
TEST MODE	B		

ANTENNA POLARITY & TEST DISTANCE: HORIZONTAL AT 3 M								
NO.	FREQ. (MHz)	EMISSION LEVEL (dBuV/m)	LIMIT (dBuV/m)	MARGIN (dB)	ANTENNA HEIGHT (m)	TABLE ANGLE (Degree)	RAW VALUE (dBuV)	CORRECTION FACTOR (dB/m)
1	49.40	36.4 QP	40.0	-3.6	1.00 H	35	46.2	-9.8
2	53.28	36.6 QP	40.0	-3.4	1.00 H	326	46.6	-10.0
3	64.92	36.5 QP	40.0	-3.5	1.00 H	100	47.6	-11.1
4	101.78	28.9 QP	43.5	-14.6	1.50 H	15	42.3	-13.4
5	144.46	25.8 QP	43.5	-17.7	1.00 H	8	35.5	-9.7
6	210.42	26.2 QP	43.5	-17.3	1.00 H	42	37.7	-11.5

Remarks:

1. Emission Level(dBuV/m) = Raw Value(dBuV) + Correction Factor(dB/m).
2. Correction Factor(dB/m) = Antenna Factor(dB/m) + Cable Factor(dB) – Pre-Amplifier Factor(dB).
3. The other emission levels were very low against the limit of frequency range 30MHz ~ 1000MHz.
4. Margin value = Emission Level – Limit value.
5. The emission levels were very low against the limit of frequency range 9kHz ~ 30MHz: the amplitude of spurious emissions attenuated more than 20 dB below the permissible value to be report.

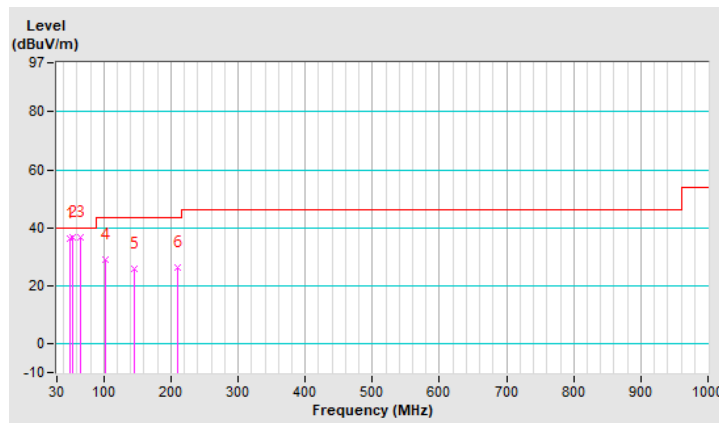

CHANNEL	TX Channel 157	DETECTOR FUNCTION	Quasi-Peak (QP)
FREQUENCY RANGE	9kHz ~ 1GHz		
TEST MODE	B		

ANTENNA POLARITY & TEST DISTANCE: VERTICAL AT 3 M								
NO.	FREQ. (MHz)	EMISSION LEVEL (dBuV/m)	LIMIT (dBuV/m)	MARGIN (dB)	ANTENNA HEIGHT (m)	TABLE ANGLE (Degree)	RAW VALUE (dBuV)	CORRECTION FACTOR (dB/m)
1	38.73	23.2 QP	40.0	-16.8	1.00 V	293	33.7	-10.5
2	52.31	22.3 QP	40.0	-17.7	1.49 V	78	32.2	-9.9
3	101.78	22.2 QP	43.5	-21.3	1.49 V	228	35.6	-13.4
4	144.46	26.5 QP	43.5	-17.0	1.00 V	267	36.2	-9.7
5	250.19	27.1 QP	46.0	-18.9	1.00 V	120	36.9	-9.8
6	480.08	28.9 QP	46.0	-17.1	1.49 V	4	33.2	-4.3

Remarks:

1. Emission Level(dBuV/m) = Raw Value(dBuV) + Correction Factor(dB/m).
2. Correction Factor(dB/m) = Antenna Factor(dB/m) + Cable Factor(dB) – Pre-Amplifier Factor(dB).
3. The other emission levels were very low against the limit of frequency range 30MHz ~ 1000MHz.
4. Margin value = Emission Level – Limit value.
5. The emission levels were very low against the limit of frequency range 9kHz ~ 30MHz: the amplitude of spurious emissions attenuated more than 20 dB below the permissible value to be report.

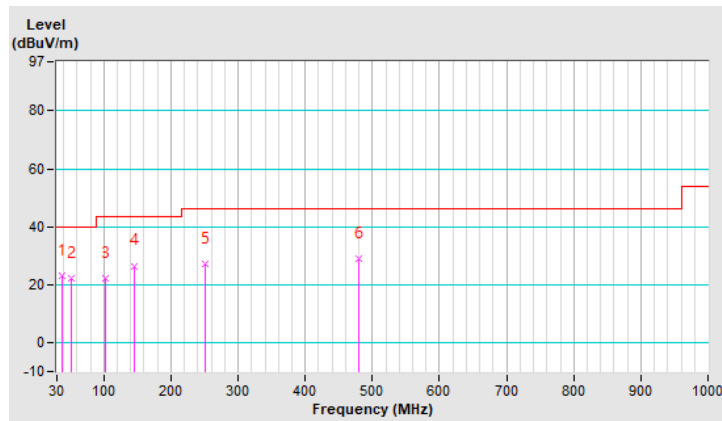

4.2 Conducted Emission Measurement

4.2.1 Limits of Conducted Emission Measurement

Frequency (MHz)	Conducted Limit (dBuV)	
	Quasi-peak	Average
0.15 - 0.5	66 - 56	56 - 46
0.50 - 5.0	56	46
5.0 - 30.0	60	50

Note: 1. The lower limit shall apply at the transition frequencies.

2. The limit decreases in line with the logarithm of the frequency in the range of 0.15 to 0.50MHz.

4.2.2 Test Instruments

Description & Manufacturer	Model No.	Serial No.	Cal. Date	Cal. Due
Test Receiver ROHDE & SCHWARZ	ESCI	100613	Dec. 10, 2018	Dec. 09, 2019
RF signal cable Woken	5D-FB	Cable-cond1-01	Sep. 05, 2019	Sep. 04, 2020
LISN ROHDE & SCHWARZ (EUT)	ENV216	101826	Feb. 21, 2019	Feb. 20, 2020
LISN ROHDE & SCHWARZ (Peripheral)	ESH3-Z5	100311	Aug. 22, 2019	Aug. 21, 2020
Software ADT	BV ADT_Cond_ V7.3.7.4	NA	NA	NA

Note: 1. The calibration interval of the above test instruments is 12 months and the calibrations are traceable to NML/ROC and NIST/USA.

2. The test was performed in HwaYa Shielded Room 1.

3. The VCCI Site Registration No. is C-12040.

4.2.3 Test Procedures

- The EUT was placed 0.4 meters from the conducting wall of the shielded room with EUT being connected to the power mains through a line impedance stabilization network (LISN). Other support units were connected to the power mains through another LISN. The two LISNs provide 50 ohm/ 50uH of coupling impedance for the measuring instrument.
- Both lines of the power mains connected to the EUT were checked for maximum conducted interference.
- The frequency range from 150kHz to 30MHz was searched. Emission levels under (Limit - 20dB) was not recorded.

Note: The resolution bandwidth and video bandwidth of test receiver is 9kHz for quasi-peak detection (QP) and average detection (AV) at frequency 0.15MHz-30MHz.

4.2.4 Deviation from Test Standard

No deviation.

4.2.5 Test Setup

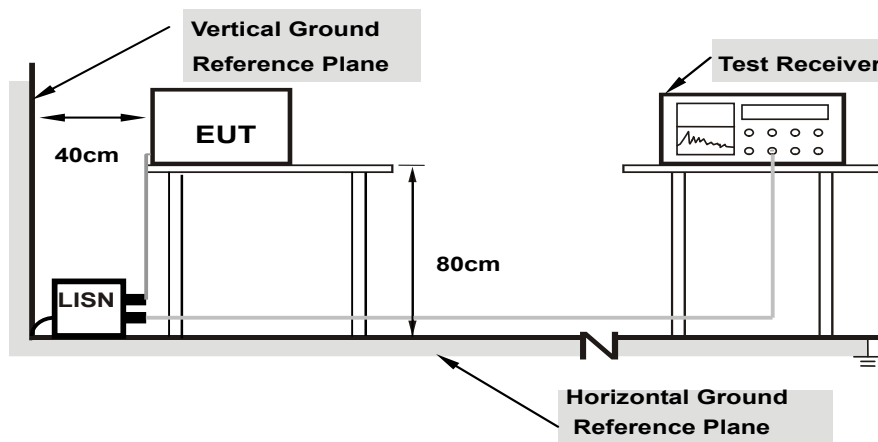

Note: 1.Support units were connected to second LISN.

For the actual test configuration, please refer to the attached file (Test Setup Photo).

4.2.6 EUT Operating Conditions

Same as 4.1.6.

4.2.7 Test Results

Worst-case data:

802.11a

Phase	Line (L)	Detector Function	Quasi-Peak (QP) / Average (AV)
Test Mode	A		

No	Freq. [MHz]	Corr. Factor (dB)	Reading Value		Emission Level		Limit		Margin	
			[dB (uV)]		[dB (uV)]		[dB (uV)]		(dB)	
			Q.P.	AV.	Q.P.	AV.	Q.P.	AV.	Q.P.	AV.
1	0.15000	9.70	25.45	19.37	35.15	29.07	66.00	56.00	-30.85	-26.93
2	0.16600	9.73	25.55	16.18	35.28	25.91	65.16	55.16	-29.88	-29.25
3	0.30600	9.84	24.22	19.26	34.06	29.10	60.08	50.08	-26.02	-20.98
4	1.21800	10.04	14.02	6.30	24.06	16.34	56.00	46.00	-31.94	-29.66
5	1.50600	10.06	10.32	0.62	20.38	10.68	56.00	46.00	-35.62	-35.32
6	20.40200	10.40	12.61	5.91	23.01	16.31	60.00	50.00	-36.99	-33.69

Remarks:

1. Q.P. and AV. are abbreviations of quasi-peak and average individually.
2. The emission levels of other frequencies were very low against the limit.
3. Margin value = Emission level - Limit value
4. Correction factor = Insertion loss + Cable loss
5. Emission Level = Correction Factor + Reading Value.

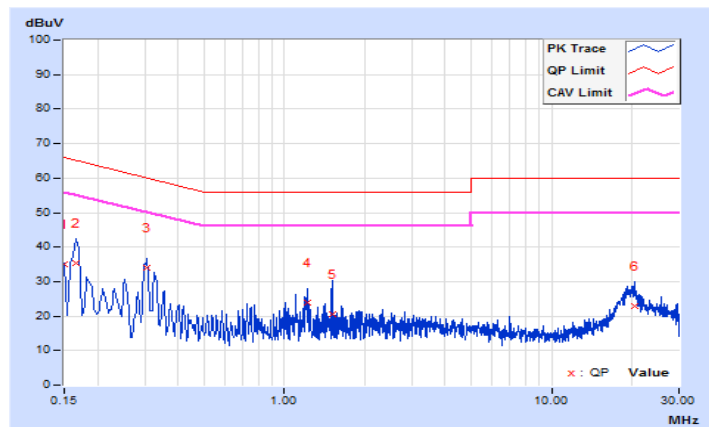

Phase	Neutral (N)	Detector Function	Quasi-Peak (QP) / Average (AV)
Test Mode	A		

No	Freq. [MHz]	Corr. Factor (dB)	Reading Value [dB (uV)]		Emission Level [dB (uV)]		Limit [dB (uV)]		Margin (dB)	
			Q.P.	AV.	Q.P.	AV.	Q.P.	AV.	Q.P.	AV.
			1	0.15000	9.68	28.52	15.06	38.20	24.74	66.00
2	0.16200	9.71	24.43	11.23	34.14	20.94	65.36	55.36	-31.22	-34.42
3	0.19000	9.78	19.39	7.72	29.17	17.50	64.04	54.04	-34.87	-36.54
4	0.30200	9.83	21.58	13.82	31.41	23.65	60.19	50.19	-28.78	-26.54
5	1.20200	9.98	7.79	1.79	17.77	11.77	56.00	46.00	-38.23	-34.23
6	19.29400	10.47	10.32	4.22	20.79	14.69	60.00	50.00	-39.21	-35.31

Remarks:

1. Q.P. and AV. are abbreviations of quasi-peak and average individually.
2. The emission levels of other frequencies were very low against the limit.
3. Margin value = Emission level - Limit value
4. Correction factor = Insertion loss + Cable loss
5. Emission Level = Correction Factor + Reading Value.

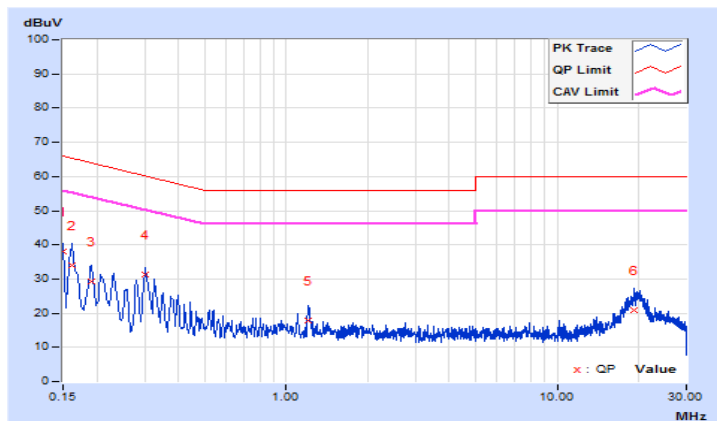

Phase	Line (L)	Detector Function	Quasi-Peak (QP) / Average (AV)
Test Mode	B		

No	Freq. [MHz]	Corr. Factor (dB)	Reading Value [dB (uV)]		Emission Level [dB (uV)]		Limit [dB (uV)]		Margin (dB)	
			Q.P.	AV.	Q.P.	AV.	Q.P.	AV.	Q.P.	AV.
			1	0.15000	9.70	33.77	22.68	43.47	32.38	66.00
2	0.18600	9.76	19.22	0.26	28.98	10.02	64.21	54.21	-35.23	-44.19
3	0.31800	9.85	19.25	8.58	29.10	18.43	59.76	49.76	-30.66	-31.33
4	0.41000	9.90	10.93	0.29	20.83	10.19	57.65	47.65	-36.82	-37.46
5	6.84600	10.25	18.40	11.98	28.65	22.23	60.00	50.00	-31.35	-27.77
6	12.67400	10.35	15.46	8.37	25.81	18.72	60.00	50.00	-34.19	-31.28

Remarks:

1. Q.P. and AV. are abbreviations of quasi-peak and average individually.
2. The emission levels of other frequencies were very low against the limit.
3. Margin value = Emission level - Limit value
4. Correction factor = Insertion loss + Cable loss
5. Emission Level = Correction Factor + Reading Value.

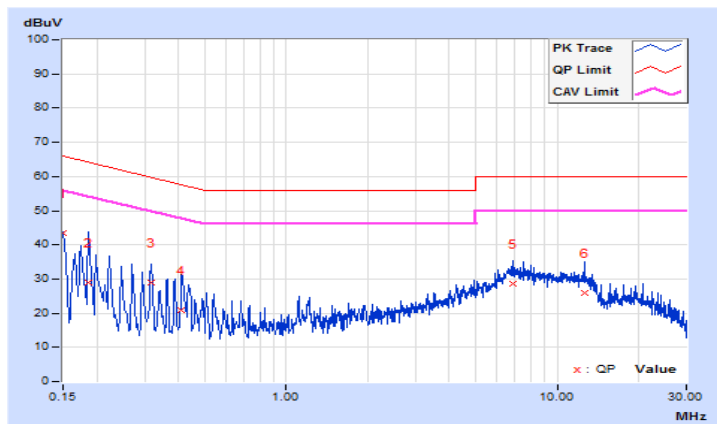

Phase	Neutral (N)	Detector Function	Quasi-Peak (QP) / Average (AV)
Test Mode	B		

No	Freq. [MHz]	Corr. Factor (dB)	Reading Value [dB (uV)]		Emission Level [dB (uV)]		Limit [dB (uV)]		Margin (dB)	
			Q.P.	AV.	Q.P.	AV.	Q.P.	AV.	Q.P.	AV.
			1	0.15000	9.68	34.46	21.48	44.14	31.16	66.00
2	0.16600	9.72	26.81	9.98	36.53	19.70	65.16	55.16	-28.63	-35.46
3	0.19800	9.80	28.76	17.44	38.56	27.24	63.69	53.69	-25.13	-26.45
4	0.42131	9.86	23.47	21.49	33.33	31.35	57.42	47.42	-24.09	-16.07
5	1.11000	9.97	13.76	9.07	23.73	19.04	56.00	46.00	-32.27	-26.96
6	6.30200	10.18	16.35	10.11	26.53	20.29	60.00	50.00	-33.47	-29.71

Remarks:

1. Q.P. and AV. are abbreviations of quasi-peak and average individually.
2. The emission levels of other frequencies were very low against the limit.
3. Margin value = Emission level - Limit value
4. Correction factor = Insertion loss + Cable loss
5. Emission Level = Correction Factor + Reading Value.

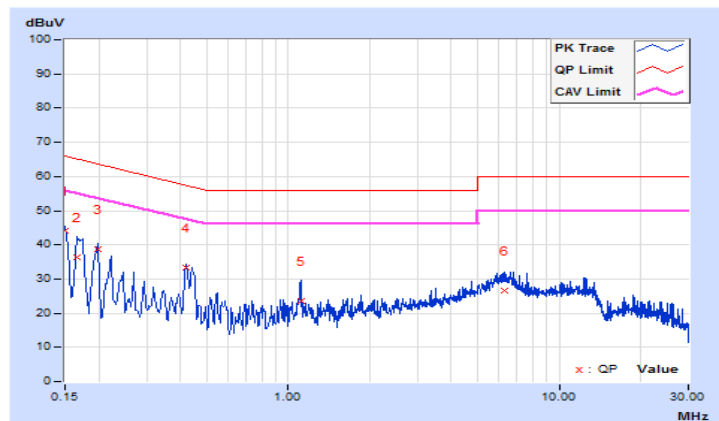

4.3 Transmit Power Measurement

4.3.1 Limits of Transmit Power Measurement

Operation Band	EUT Category		Limit
U-NII-1		Outdoor Access Point	1 Watt (30 dBm) (Max. e.i.r.p \leq 125mW(21 dBm) at any elevation angle above 30 degrees as measured from the horizon)
		Fixed point-to-point Access Point	1 Watt (30 dBm)
	√	Indoor Access Point	1 Watt (30 dBm)
		Mobile and Portable client device	250mW (24 dBm)
U-NII-2A			250mW (24 dBm) or 11 dBm+10 log B*
U-NII-2C			250mW (24 dBm) or 11 dBm+10 log B*
U-NII-3	√		1 Watt (30 dBm)

*B is the 26 dB emission bandwidth in megahertz

Per KDB 662911 Method of conducted output power measurement on IEEE 802.11 devices,

Array Gain = 0 dB (i.e., no array gain) for $N_{ANT} \leq 4$;

Array Gain = 0 dB (i.e., no array gain) for channel widths ≥ 40 MHz for any N_{ANT} ;

Array Gain = $5 \log(N_{ANT}/N_{SS})$ dB or 3 dB, whichever is less for 20-MHz channel widths with $N_{ANT} \geq 5$.

For power measurements on all other devices: Array Gain = $10 \log(N_{ANT}/N_{SS})$ dB.

4.3.2 Test Setup

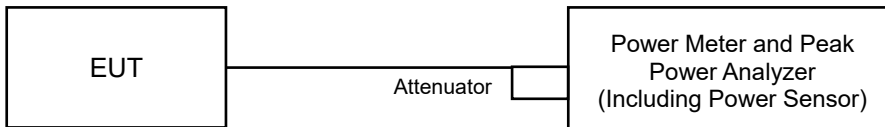

4.3.3 Test Instruments

Refer to section 4.1.2 to get information of above instrument.

4.3.4 Test Procedure

Method PM is used to perform output power measurement, trigger and gating function of wide band power meter is enabled to measure max output power of TX on burst and set the detector to average. Duty factor is not added to measured value.

4.3.5 Deviation from Test Standard

No deviation.

4.3.6 EUT Operating Conditions

The software provided by client to enable the EUT under transmission condition continuously at lowest, middle and highest channel frequencies individually.

4.3.7 Test Result

CDD Mode

802.11a

Chan.	Freq. (MHz)	Maximum Conducted Power (dBm)		Total Power (mW)	Total Power (dBm)	Power Limit (dBm)	Pass / Fail
		Chain 0	Chain 1				
36	5180	20.82	20.84	242.120	23.84	30.00	Pass
40	5200	21.93	21.98	313.716	24.97	30.00	Pass
48	5240	22.32	22.18	335.804	25.26	30.00	Pass
149	5745	23.11	23.29	417.948	26.21	30.00	Pass
157	5785	23.56	23.48	449.830	26.53	30.00	Pass
165	5825	23.02	23.19	408.896	26.12	30.00	Pass

802.11ac (VHT20)

Chan.	Freq. (MHz)	Maximum Conducted Power (dBm)		Total Power (mW)	Total Power (dBm)	Power Limit (dBm)	Pass / Fail
		Chain 0	Chain 1				
36	5180	21.21	21.05	259.480	24.14	30.00	Pass
40	5200	23.11	23.01	404.630	26.07	30.00	Pass
48	5240	23.41	23.25	430.629	26.34	30.00	Pass
149	5745	22.62	22.85	375.562	25.75	30.00	Pass
157	5785	23.11	23.16	411.658	26.15	30.00	Pass
165	5825	22.72	22.91	382.502	25.83	30.00	Pass

802.11ac (VHT40)

Chan.	Freq. (MHz)	Maximum Conducted Power (dBm)		Total Power (mW)	Total Power (dBm)	Power Limit (dBm)	Pass / Fail
		Chain 0	Chain 1				
38	5190	17.89	17.71	120.538	20.81	30.00	Pass
46	5230	23.35	23.11	420.916	26.24	30.00	Pass
151	5755	22.85	23.01	392.738	25.94	30.00	Pass
159	5795	23.16	23.18	414.984	26.18	30.00	Pass

802.11ac (VHT80)

Chan.	Freq. (MHz)	Maximum Conducted Power (dBm)		Total Power (mW)	Total Power (dBm)	Power Limit (dBm)	Pass / Fail
		Chain 0	Chain 1				
42	5210	16.28	16.24	84.535	19.27	30.00	Pass
155	5775	20.75	20.81	239.354	23.79	30.00	Pass

802.11ax (HE20)

Chan.	Freq. (MHz)	Maximum Conducted Power (dBm)		Total Power (mW)	Total Power (dBm)	Power Limit (dBm)	Pass / Fail
		Chain 0	Chain 1				
36	5180	21.27	21.15	264.285	24.22	30.00	Pass
40	5200	23.13	23.08	408.825	26.12	30.00	Pass
48	5240	23.43	23.28	433.107	26.37	30.00	Pass
149	5745	22.68	22.91	380.787	25.81	30.00	Pass
157	5785	23.17	23.22	417.385	26.21	30.00	Pass
165	5825	22.78	22.95	386.913	25.88	30.00	Pass

802.11ax (HE40)

Chan.	Freq. (MHz)	Maximum Conducted Power (dBm)		Total Power (mW)	Total Power (dBm)	Power Limit (dBm)	Pass / Fail
		Chain 0	Chain 1				
38	5190	17.92	17.77	121.785	20.86	30.00	Pass
46	5230	23.41	23.17	426.771	26.30	30.00	Pass
151	5755	22.91	23.06	397.736	26.00	30.00	Pass
159	5795	23.32	23.25	426.132	26.30	30.00	Pass

802.11ax (HE80)

Chan.	Freq. (MHz)	Maximum Conducted Power (dBm)		Total Power (mW)	Total Power (dBm)	Power Limit (dBm)	Pass / Fail
		Chain 0	Chain 1				
42	5210	16.31	16.28	85.218	19.31	30.00	Pass
155	5775	20.81	20.95	244.955	23.89	30.00	Pass

Beamforming Mode

802.11ac (VHT20)

Chan.	Freq. (MHz)	Maximum Conducted Power (dBm)		Total Power (mW)	Total Power (dBm)	Power Limit (dBm)	Pass / Fail
		Chain 0	Chain 1				
36	5180	18.20	18.04	129.749	21.13	27.46	Pass
40	5200	20.10	20.00	202.329	23.06	27.46	Pass
48	5240	20.40	20.24	215.330	23.33	27.46	Pass
149	5745	19.61	19.84	187.794	22.74	27.22	Pass
157	5785	20.10	20.15	205.843	23.14	27.22	Pass
165	5825	19.71	19.90	191.265	22.82	27.22	Pass

Note:

- 5180-5240MHz: Directional gain = $10 \log[(10^{G1/20} + 10^{G2/20} + \dots + 10^{GN/20})^2/2]$ = 8.54dBi > 6dBi, so the power limit shall be reduced to 30-(8.54-6) = 27.46dBm.
- 5745-5825MHz: Directional gain = $10 \log[(10^{G1/20} + 10^{G2/20} + \dots + 10^{GN/20})^2/2]$ = 8.78dBi > 6dBi, so the power limit shall be reduced to 30-(8.78-6) = 27.22dBm.

802.11ac (VHT40)

Chan.	Freq. (MHz)	Maximum Conducted Power (dBm)		Total Power (mW)	Total Power (dBm)	Power Limit (dBm)	Pass / Fail
		Chain 0	Chain 1				
38	5190	14.88	14.70	60.273	17.80	27.46	Pass
46	5230	20.34	20.10	210.472	23.23	27.46	Pass
151	5755	19.84	20.00	196.383	22.93	27.22	Pass
159	5795	20.15	20.17	207.506	23.17	27.22	Pass

Note:

- 5180-5240MHz: Directional gain = $10 \log[(10^{G1/20} + 10^{G2/20} + \dots + 10^{GN/20})^2/2]$ = 8.54dBi > 6dBi, so the power limit shall be reduced to 30-(8.54-6) = 27.46dBm.
- 5745-5825MHz: Directional gain = $10 \log[(10^{G1/20} + 10^{G2/20} + \dots + 10^{GN/20})^2/2]$ = 8.78dBi > 6dBi, so the power limit shall be reduced to 30-(8.78-6) = 27.22dBm.

802.11ac (VHT80)

Chan.	Freq. (MHz)	Maximum Conducted Power (dBm)		Total Power (mW)	Total Power (dBm)	Power Limit (dBm)	Pass / Fail
		Chain 0	Chain 1				
42	5210	13.27	13.23	42.270	16.26	27.46	Pass
155	5775	17.74	17.80	119.685	20.78	27.22	Pass

Note:

- 5180-5240MHz: Directional gain = $10 \log[(10^{G1/20} + 10^{G2/20} + \dots + 10^{GN/20})^2/2]$ = 8.54dBi > 6dBi, so the power limit shall be reduced to 30-(8.54-6) = 27.46dBm.
- 5745-5825MHz: Directional gain = $10 \log[(10^{G1/20} + 10^{G2/20} + \dots + 10^{GN/20})^2/2]$ = 8.78dBi > 6dBi, so the power limit shall be reduced to 30-(8.78-6) = 27.22dBm.

802.11ax (HE20)

Chan.	Freq. (MHz)	Maximum Conducted Power (dBm)		Total Power (mW)	Total Power (dBm)	Power Limit (dBm)	Pass / Fail
		Chain 0	Chain 1				
36	5180	18.26	18.14	132.151	21.21	27.46	Pass
40	5200	20.12	20.07	204.427	23.11	27.46	Pass
48	5240	20.42	20.27	216.568	23.36	27.46	Pass
149	5745	19.67	19.90	190.407	22.80	27.22	Pass
157	5785	20.16	20.21	208.707	23.20	27.22	Pass
165	5825	19.77	19.94	193.470	22.87	27.22	Pass

Note:

- 5180-5240MHz: Directional gain = $10 \log[(10^{G1/20} + 10^{G2/20} + \dots + 10^{GN/20})^2/2] = 8.54\text{dBi} > 6\text{dBi}$, so the power limit shall be reduced to $30-(8.54-6) = 27.46\text{dBm}$.
- 5745-5825MHz: Directional gain = $10 \log[(10^{G1/20} + 10^{G2/20} + \dots + 10^{GN/20})^2/2] = 8.78\text{dBi} > 6\text{dBi}$, so the power limit shall be reduced to $30-(8.78-6) = 27.22\text{dBm}$.

802.11ax (HE40)

Chan.	Freq. (MHz)	Maximum Conducted Power (dBm)		Total Power (mW)	Total Power (dBm)	Power Limit (dBm)	Pass / Fail
		Chain 0	Chain 1				
38	5190	14.91	14.76	60.897	17.85	27.46	Pass
46	5230	20.40	20.16	213.401	23.29	27.46	Pass
151	5755	19.90	20.05	198.882	22.99	27.22	Pass
159	5795	20.31	20.24	213.081	23.29	27.22	Pass

Note:

- 5180-5240MHz: Directional gain = $10 \log[(10^{G1/20} + 10^{G2/20} + \dots + 10^{GN/20})^2/2] = 8.54\text{dBi} > 6\text{dBi}$, so the power limit shall be reduced to $30-(8.54-6) = 27.46\text{dBm}$.
- 5745-5825MHz: Directional gain = $10 \log[(10^{G1/20} + 10^{G2/20} + \dots + 10^{GN/20})^2/2] = 8.78\text{dBi} > 6\text{dBi}$, so the power limit shall be reduced to $30-(8.78-6) = 27.22\text{dBm}$.

802.11ax (HE80)

Chan.	Freq. (MHz)	Maximum Conducted Power (dBm)		Total Power (mW)	Total Power (dBm)	Power Limit (dBm)	Pass / Fail
		Chain 0	Chain 1				
42	5210	13.30	13.27	42.612	16.30	27.46	Pass
155	5775	17.80	17.94	122.486	20.88	27.22	Pass

Note:

- 5180-5240MHz: Directional gain = $10 \log[(10^{G1/20} + 10^{G2/20} + \dots + 10^{GN/20})^2/2] = 8.54\text{dBi} > 6\text{dBi}$, so the power limit shall be reduced to $30-(8.54-6) = 27.46\text{dBm}$.
- 5745-5825MHz: Directional gain = $10 \log[(10^{G1/20} + 10^{G2/20} + \dots + 10^{GN/20})^2/2] = 8.78\text{dBi} > 6\text{dBi}$, so the power limit shall be reduced to $30-(8.78-6) = 27.22\text{dBm}$.

4.4 Occupied Bandwidth Measurement

4.4.1 Test Setup

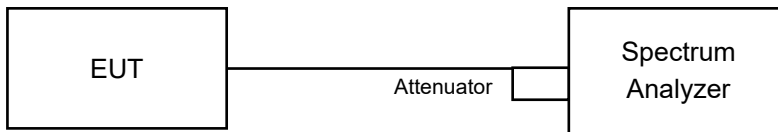

4.4.2 Test Instruments

Refer to section 4.1.2 to get information of above instrument.

4.4.3 Test Procedure

The transmitter output was connected to the spectrum analyzer through an attenuator. The bandwidth of the fundamental frequency was measured by spectrum analyzer with resolution bandwidth in the range of 1% to 5% of the anticipated emission bandwidth, and a video bandwidth at least 3x the resolution bandwidth and set the detector to sampling. The width of a frequency band such that, below the lower and above the upper frequency limits, the mean powers emitted are each equal to a specified percentage 0.5 %of the total mean power of a given emission.

4.4.4 Test Result

802.11a

Chan.	Freq. (MHz)	Occupied Bandwidth (MHz)	
		Chain 0	Chain 1
36	5180	16.68	16.44
40	5200	16.68	16.56
48	5240	17.04	16.80
149	5745	17.76	18.48
157	5785	19.56	20.88
165	5825	18.72	22.20

802.11ax (HE20)

Chan.	Freq. (MHz)	Occupied Bandwidth (MHz)	
		Chain 0	Chain 1
36	5180	18.96	19.08
40	5200	18.96	19.32
48	5240	19.08	19.32
149	5745	19.32	19.44
157	5785	19.56	19.80
165	5825	19.32	20.16

802.11ax (HE40)

Chan.	Freq. (MHz)	Occupied Bandwidth (MHz)	
		Chain 0	Chain 1
38	5190	37.56	37.80
46	5230	38.28	38.40
151	5755	38.16	38.64
159	5795	38.28	39.72

802.11ax (HE80)

Chan.	Freq. (MHz)	Occupied Bandwidth (MHz)	
		Chain 0	Chain 1
42	5210	76.80	76.80
155	5775	76.80	76.80

Spectrum Plot of Worst Value

802.11a

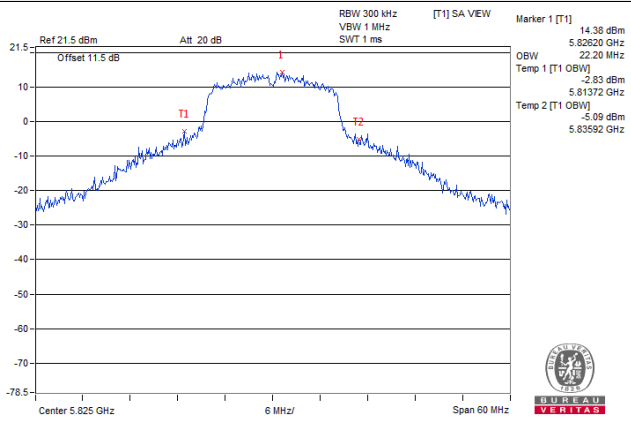

802.11ax (HE20)

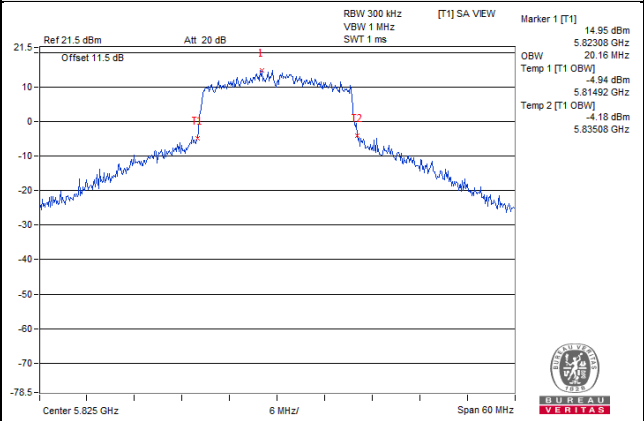

802.11ax (HE40)

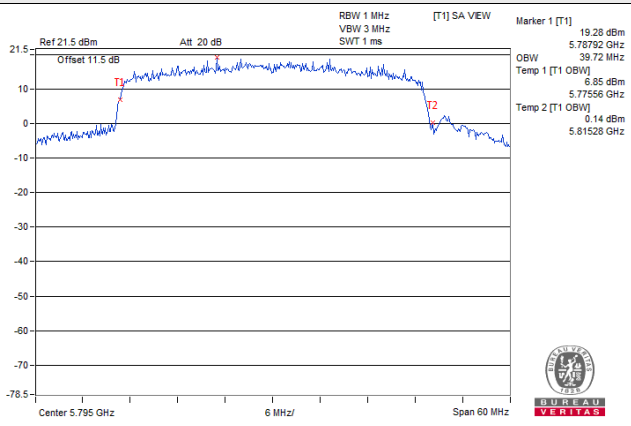

802.11ax (HE80)

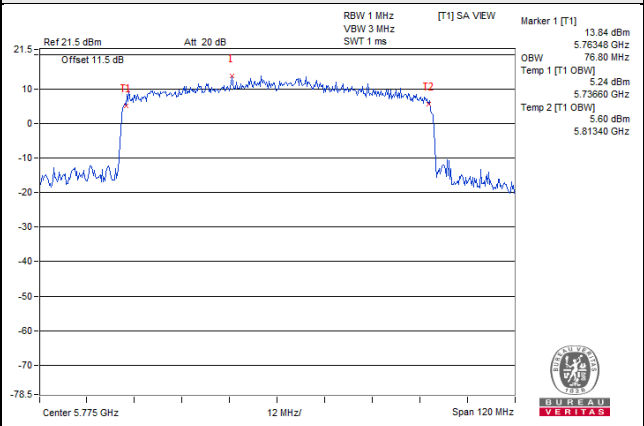

Spectrum Plot for near By DFS Band

802.11a / Chain 0 / CH 48

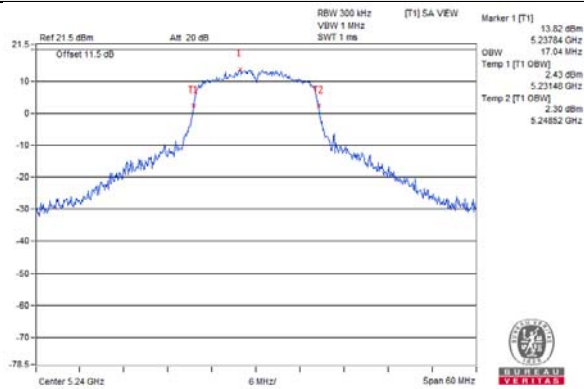

802.11a / Chain 1 / CH 48

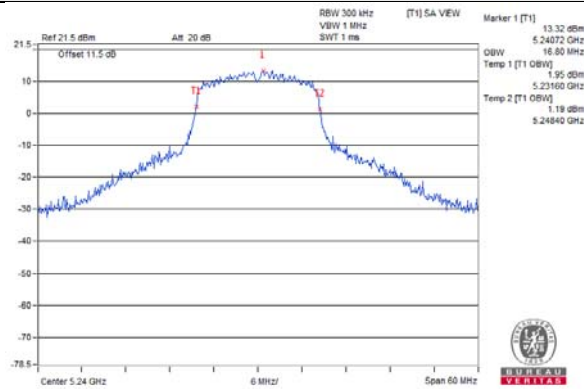

802.11ax (HE20) / Chain 0 / CH 48

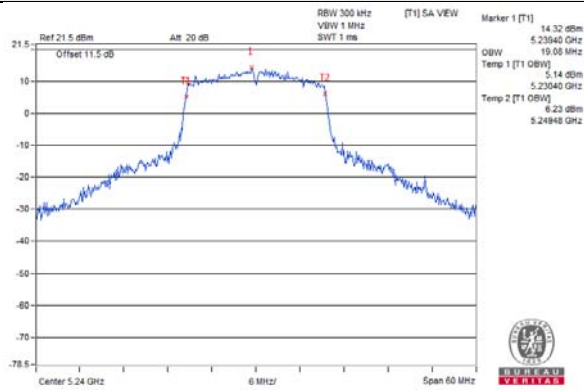

802.11ax (HE20) / Chain 1 / CH 48

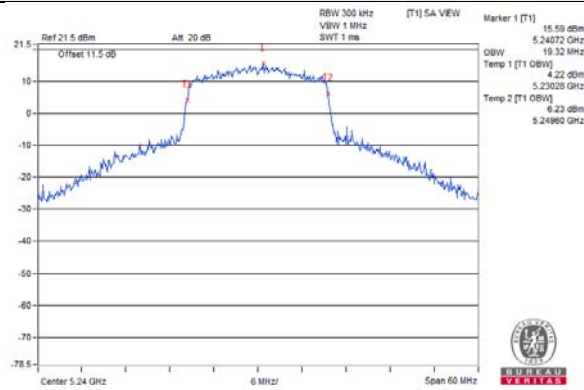

802.11ax (HE40) / Chain 0 / CH 46

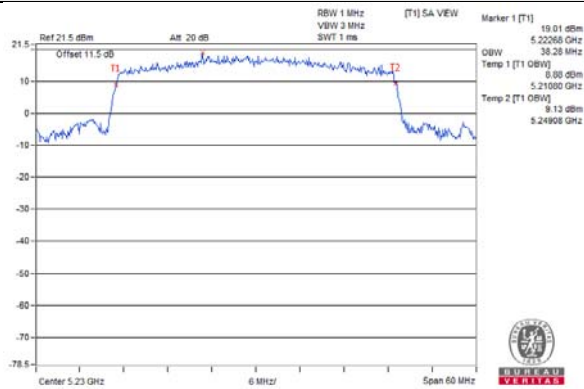

802.11ax (HE40) / Chain 1 / CH 46

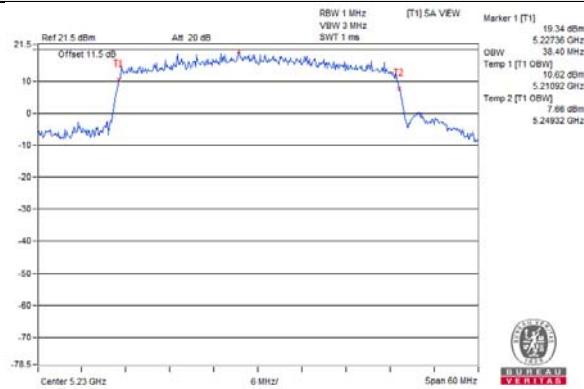

802.11ax (HE80) / Chain 0 / CH 42

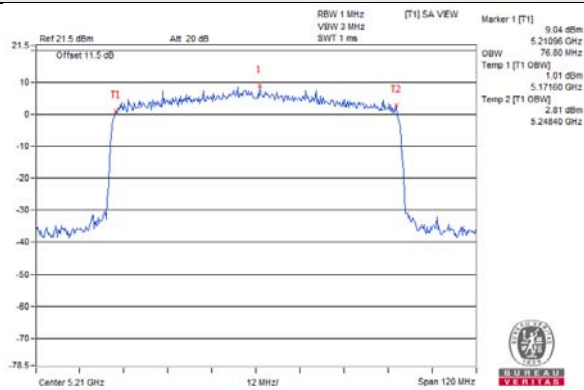

802.11ax (HE80) / Chain 1 / CH 42

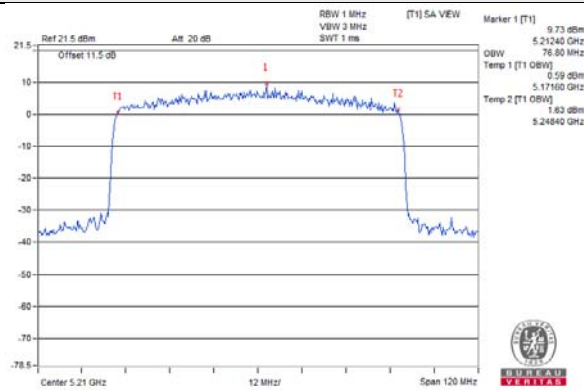

Spectrum Plot for near By DFS Band

802.11a / Chain 0 / CH 149

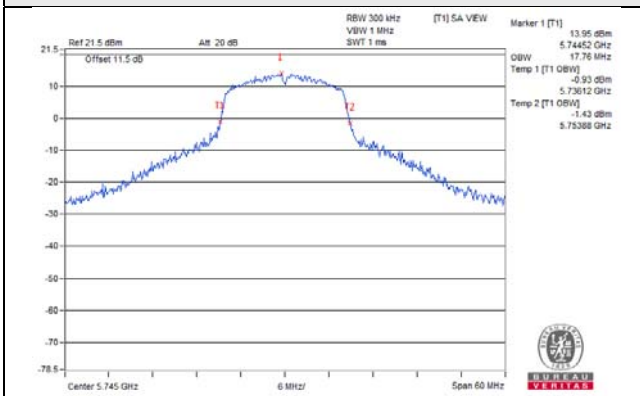

802.11a / Chain 1 / CH 149

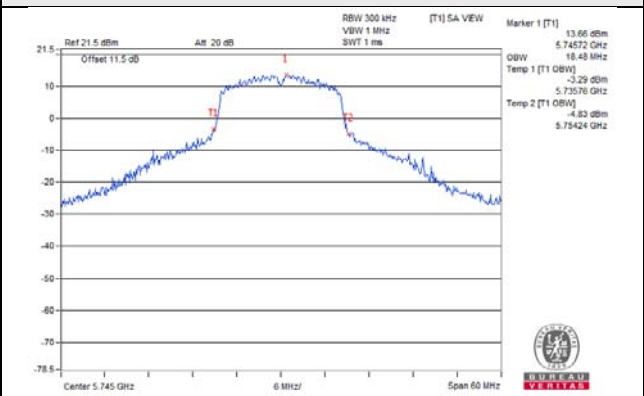

802.11ax (HE20) / Chain 0 / CH 149

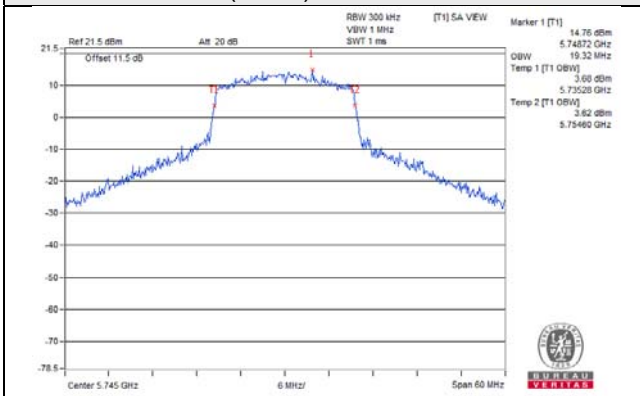

802.11ax (HE20) / Chain 1 / CH 149

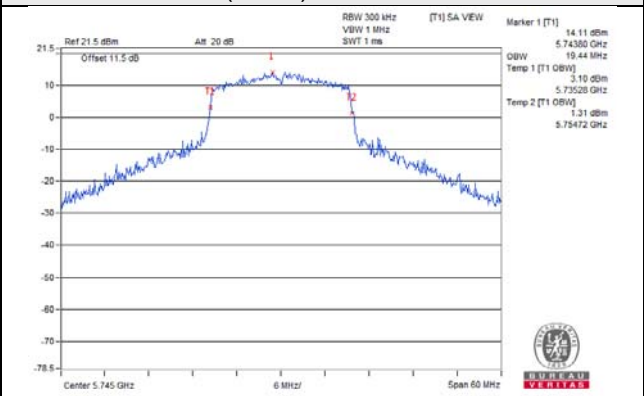

802.11ax (HE40) / Chain 0 / CH 151

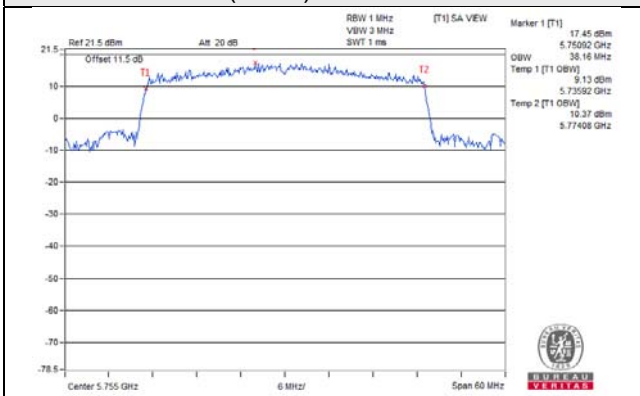

802.11ax (HE40) / Chain 1 / CH 151

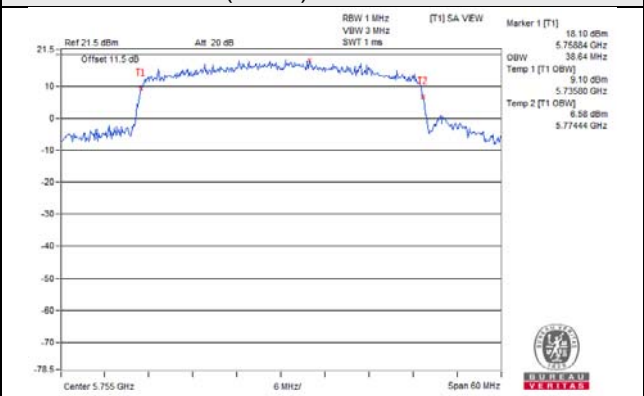

802.11ax (HE80) / Chain 0 / CH 155

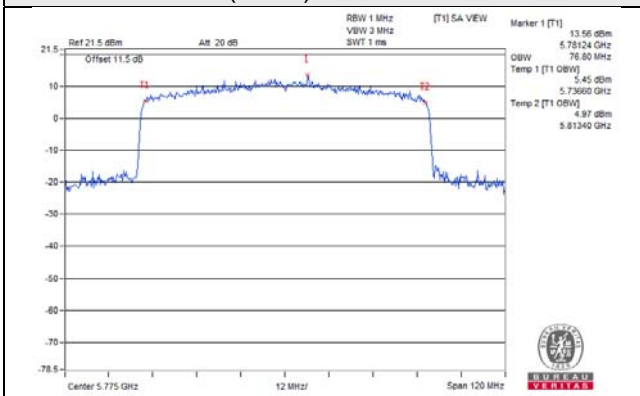

802.11ax (HE80) / Chain 1 / CH 155

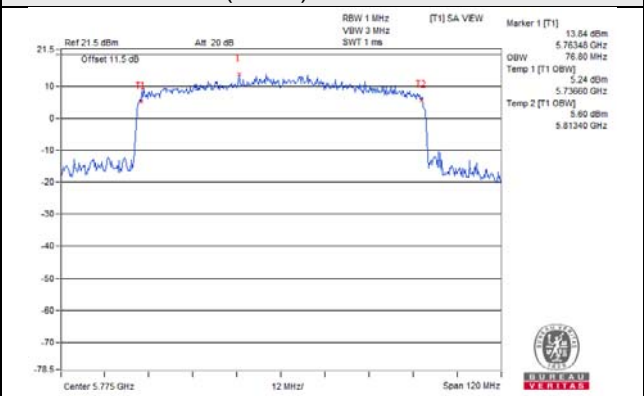

4.5 Peak Power Spectral Density Measurement

4.5.1 Limits of Peak Power Spectral Density Measurement

Operation Band	EUT Category		Limit
U-NII-1		Outdoor Access Point	17dBm/ MHz
		Fixed point-to-point Access Point	
	√	Indoor Access Point	
		Mobile and Portable client device	11dBm/ MHz
U-NII-2A			11dBm/ MHz
U-NII-2C			11dBm/ MHz
U-NII-3	√		30dBm/ 500kHz

4.5.2 Test Setup

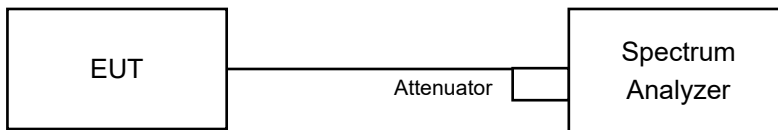

4.5.3 Test Instruments

Refer to section 4.1.2 to get information of above instrument.

4.5.4 Test Procedures

For U-NII-1 band:

Using method SA-2

- Set span to encompass the entire emission bandwidth (EBW) of the signal.
- Set RBW = 1MHz, Set VBW \geq 3 MHz, Detector = RMS
- Set Channel power measure = 1MHz
- Sweep time = auto, trigger set to "free run".
- Trace average at least 100 traces in power averaging mode.
- Record the max value and add 10 log (1/duty cycle)

For U-NII-3 band:

- Set span to encompass the entire emission bandwidth (EBW) of the signal.
- Set RBW = 300 kHz, Set VBW \geq 1 MHz, Detector = RMS
- Use the peak marker function to determine the maximum power level in any 300 kHz band segment within the fundamental EBW.
- Scale the observed power level to an equivalent value in 500 kHz by adjusting (reducing) the measured power by a bandwidth correction factor (BWCF) where $BWCF = 10\log(500 \text{ kHz} / 300 \text{ kHz})$
- Sweep time = auto, trigger set to "free run".
- Trace average at least 100 traces in power averaging mode.
- Record the max value and add 10 log (1/duty cycle)

4.5.5 Deviation from Test Standard

No deviation.

4.5.6 EUT Operating Conditions

Same as 4.3.6.

4.5.7 Test Results

For U-NII-1 band:

802.11a

Chan.	Freq. (MHz)	PSD w/o Duty Factor (dBm/MHz)		Duty Factor (dB)	Total PSD with Duty Factor (dBm/MHz)	Max. Limit (dBm/MHz)	Pass / Fail
		Chain 0	Chain 1				
36	5180	8.40	7.79	0.18	11.30	14.46	Pass
40	5200	9.69	8.96	0.18	12.53	14.46	Pass
48	5240	9.89	9.26	0.18	12.78	14.46	Pass

Note:

- Method E) 2) a) of power density measurement of KDB 662911 is using for calculating total power density. Total power density is summing entire spectra across corresponding frequency bins on the various outputs by computer.
- Directional gain = $10 \log[(10^{G1/20} + 10^{G2/20} + \dots + 10^{GN/20})^2/2] = 8.54\text{dBi} > 6\text{dBi}$, so the power density limit shall be reduced to $17 - (8.54 - 6) = 14.46\text{dBm}$.
- Refer to section 3.3 for duty cycle spectrum plot.

802.11ax (HE20)

Chan.	Freq. (MHz)	PSD w/o Duty Factor (dBm/MHz)		Duty Factor (dB)	Total PSD with Duty Factor (dBm/MHz)	Max. Limit (dBm/MHz)	Pass / Fail
		Chain 0	Chain 1				
36	5180	7.88	7.34	0.29	10.92	14.46	Pass
40	5200	8.30	9.32	0.29	12.14	14.46	Pass
48	5240	8.32	9.44	0.29	12.22	14.46	Pass

Note:

- Method E) 2) a) of power density measurement of KDB 662911 is using for calculating total power density. Total power density is summing entire spectra across corresponding frequency bins on the various outputs by computer.
- Directional gain = $10 \log[(10^{G1/20} + 10^{G2/20} + \dots + 10^{GN/20})^2/2] = 8.54\text{dBi} > 6\text{dBi}$, so the power density limit shall be reduced to $17 - (8.54 - 6) = 14.46\text{dBm}$.
- Refer to section 3.3 for duty cycle spectrum plot.

802.11ax (HE40)

Chan.	Freq. (MHz)	PSD w/o Duty Factor (dBm/MHz)		Duty Factor (dB)	Total PSD with Duty Factor (dBm/MHz)	Max. Limit (dBm/MHz)	Pass / Fail
		Chain 0	Chain 1				
38	5190	1.20	0.76	0.46	4.46	14.46	Pass
46	5230	6.66	6.26	0.46	9.93	14.46	Pass

Note:

- Method E) 2) a) of power density measurement of KDB 662911 is using for calculating total power density. Total power density is summing entire spectra across corresponding frequency bins on the various outputs by computer.
- Directional gain = $10 \log[(10^{G1/20} + 10^{G2/20} + \dots + 10^{GN/20})^2/2] = 8.54\text{dBi} > 6\text{dBi}$, so the power density limit shall be reduced to $17 - (8.54 - 6) = 14.46\text{dBm}$.
- Refer to section 3.3 for duty cycle spectrum plot.

802.11ax (HE80)

Chan.	Freq. (MHz)	PSD w/o Duty Factor (dBm/MHz)		Duty Factor (dB)	Total PSD with Duty Factor (dBm/MHz)	Max. Limit (dBm/MHz)	Pass / Fail
		Chain 0	Chain 1				
42	5210	-3.50	-3.71	0.84	0.25	14.46	Pass

Note:

- Method E) 2) a) of power density measurement of KDB 662911 is using for calculating total power density. Total power density is summing entire spectra across corresponding frequency bins on the various outputs by computer.
- Directional gain = $10 \log[(10^{G1/20} + 10^{G2/20} + \dots + 10^{GN/20})^2/2] = 8.54\text{dBi} > 6\text{dBi}$, so the power density limit shall be reduced to $17 - (8.54 - 6) = 14.46\text{dBm}$.
- Refer to section 3.3 for duty cycle spectrum plot.

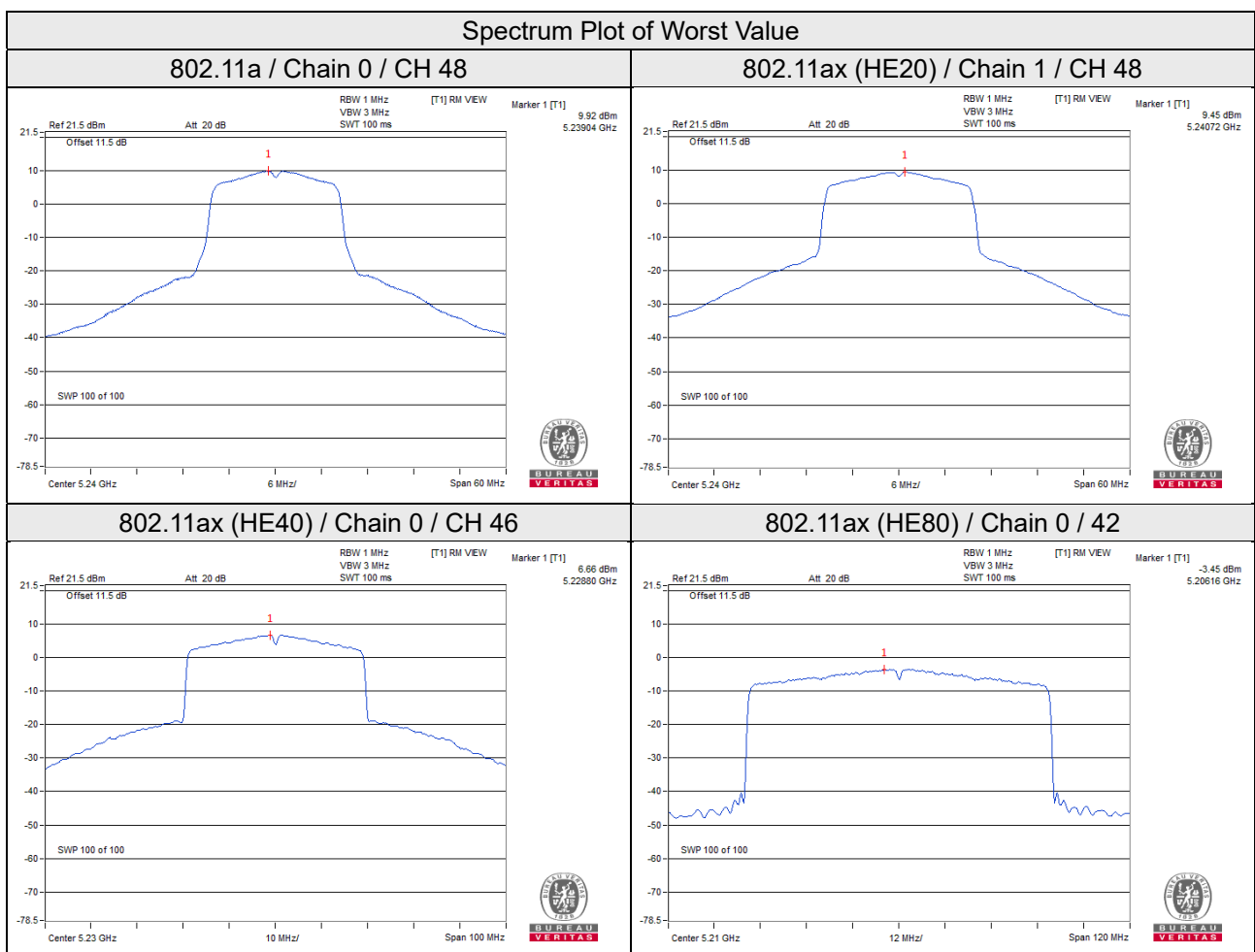

For U-NII-3 band:

802.11a

TX chain	Chan.	Freq. (MHz)	PSD W/O Duty Factor		10 log (N=2) dB	Duty Factor (dB)	Total PSD With Duty Factor (dBm/500kHz)	Limit (dBm/500kHz)	Pass / Fail
			(dBm/300kHz)	(dBm/500kHz)					
0	149	5745	2.07	4.29	3.01	0.18	7.48	27.22	Pass
	157	5785	2.18	4.40	3.01	0.18	7.59	27.22	Pass
	165	5825	2.31	4.53	3.01	0.18	7.72	27.22	Pass
1	149	5745	1.53	3.75	3.01	0.18	6.94	27.22	Pass
	157	5785	1.95	4.17	3.01	0.18	7.36	27.22	Pass
	165	5825	1.89	4.11	3.01	0.18	7.30	27.22	Pass

Note:

- Method E) 2) c) of power density measurement of KDB 662911 is using for calculating total power density, Measure and add 10 log (N_{ANT}) dB.
- Directional gain = $10 \log[(10^{G1/20} + 10^{G2/20} + \dots + 10^{GN/20})^2/2] = 8.78\text{dBi} > 6\text{dBi}$, so the power density limit shall be reduced to $30 - (8.78 - 6) = 27.22\text{dBm}$.
- Refer to section 3.3 for duty cycle spectrum plot.

802.11ax (HE20)

TX chain	Chan.	Freq. (MHz)	PSD W/O Duty Factor		10 log (N=2) dB	Duty Factor (dB)	Total PSD With Duty Factor (dBm/500kHz)	Limit (dBm/500kHz)	Pass / Fail
			(dBm/300kHz)	(dBm/500kHz)					
0	149	5745	-0.31	1.91	3.01	0.29	5.21	27.22	Pass
	157	5785	0.25	2.47	3.01	0.29	5.77	27.22	Pass
	165	5825	0.06	2.28	3.01	0.29	5.58	27.22	Pass
1	149	5745	-0.43	1.79	3.01	0.29	5.09	27.22	Pass
	157	5785	0.10	2.32	3.01	0.29	5.62	27.22	Pass
	165	5825	0.35	2.57	3.01	0.29	5.87	27.22	Pass

Note:

- Method E) 2) c) of power density measurement of KDB 662911 is using for calculating total power density, Measure and add 10 log (N_{ANT}) dB.
- Directional gain = $10 \log[(10^{G1/20} + 10^{G2/20} + \dots + 10^{GN/20})^2/2] = 8.78\text{dBi} > 6\text{dBi}$, so the power density limit shall be reduced to $30 - (8.78 - 6) = 27.22\text{dBm}$.
- Refer to section 3.3 for duty cycle spectrum plot.

802.11ax (HE40)

TX chain	Chan.	Freq. (MHz)	PSD W/O Duty Factor		10 log (N=2) dB	Duty Factor (dB)	Total PSD With Duty Factor (dBm/500kHz)	Limit (dBm/500kHz)	Pass / Fail
			(dBm/300kHz)	(dBm/500kHz)					
0	151	5755	-3.53	-1.31	3.01	0.46	2.16	27.22	Pass
	159	5795	-3.01	-0.79	3.01	0.46	2.68	27.22	Pass
1	151	5755	-2.88	-0.66	3.01	0.46	2.81	27.22	Pass
	159	5795	-2.54	-0.32	3.01	0.46	3.15	27.22	Pass

Note:

1. Method E) 2) c) of power density measurement of KDB 662911 is using for calculating total power density, Measure and add $10 \log (N_{ANT})$ dB.
2. Directional gain = $10 \log[(10^{G1/20} + 10^{G2/20} + \dots + 10^{GN/20})^2/2] = 8.78\text{dBi} > 6\text{dBi}$, so the power density limit shall be reduced to $30 - (8.78 - 6) = 27.22\text{dBm}$.
3. Refer to section 3.3 for duty cycle spectrum plot.

802.11ax (HE80)

TX chain	Chan.	Freq. (MHz)	PSD W/O Duty Factor		10 log (N=2) dB	Duty Factor (dB)	Total PSD With Duty Factor (dBm/500kHz)	Limit (dBm/500kHz)	Pass / Fail
			(dBm/300kHz)	(dBm/500kHz)					
0	155	5775	-8.34	-6.12	3.01	0.84	-2.27	27.22	Pass
1	155	5775	-7.54	-5.32	3.01	0.84	-1.47	27.22	Pass

Note:

1. Method E) 2) c) of power density measurement of KDB 662911 is using for calculating total power density, Measure and add $10 \log (N_{ANT})$ dB.
2. Directional gain = $10 \log[(10^{G1/20} + 10^{G2/20} + \dots + 10^{GN/20})^2/2] = 8.78\text{dBi} > 6\text{dBi}$, so the power density limit shall be reduced to $30 - (8.78 - 6) = 27.22\text{dBm}$.
3. Refer to section 3.3 for duty cycle spectrum plot.

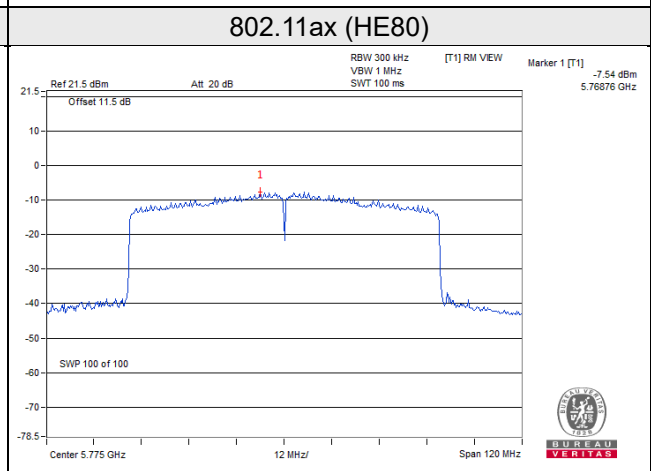
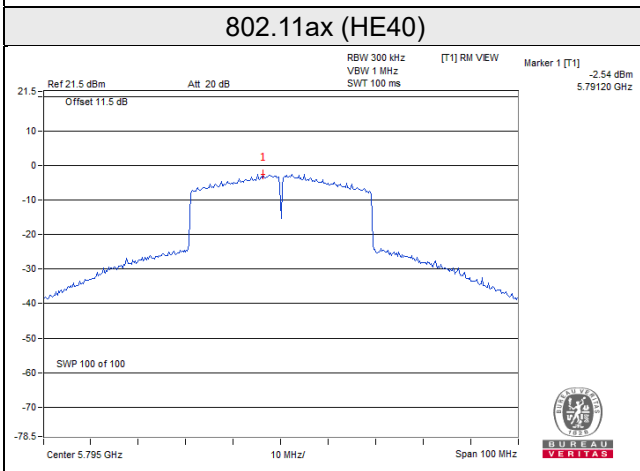
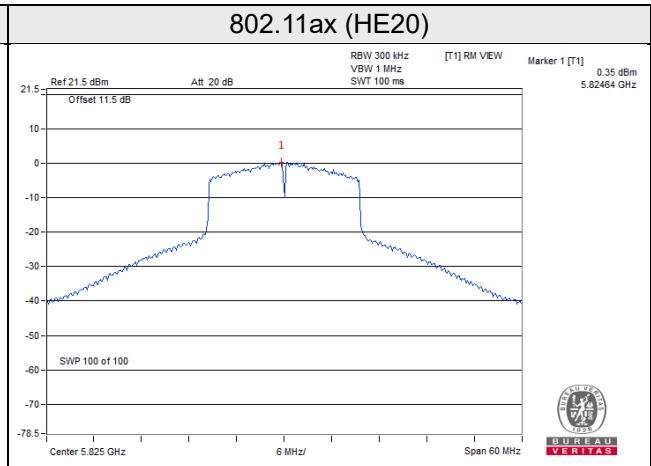
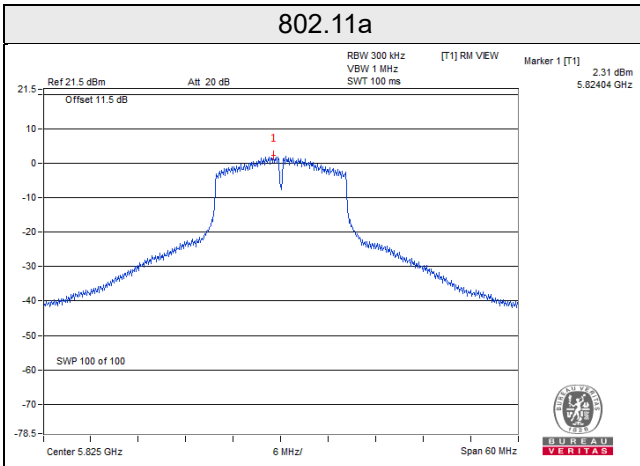

4.6 Frequency Stability

4.6.1 Limits of Frequency Stability Measurement

The frequency of the carrier signal shall be maintained within band of operation

4.6.2 Test Setup

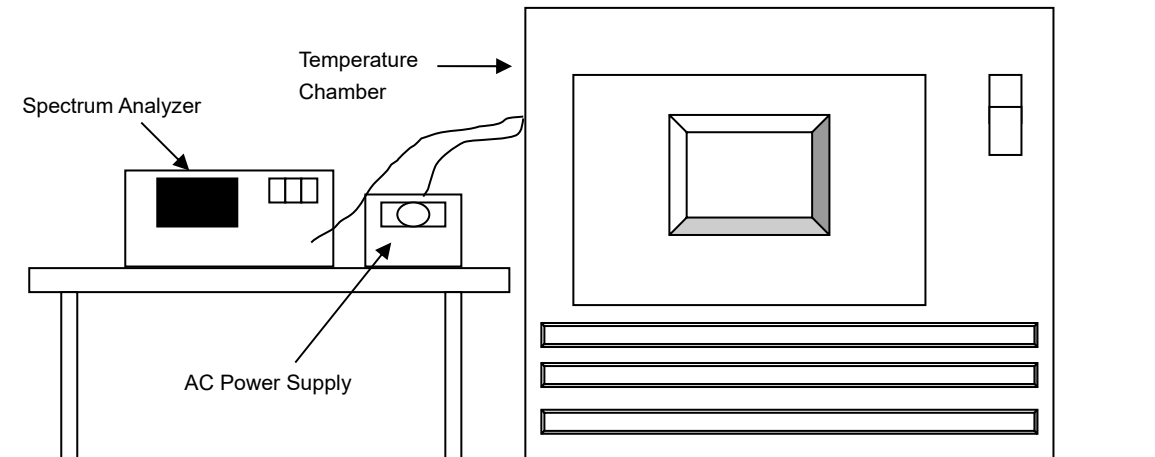

4.6.3 Test Instruments

Description & Manufacturer	Model No.	Serial No.	Cal. Date	Cal. Due
Spectrum Analyzer ROHDE & SCHWARZ	FSP40	100040	Sep. 23, 2019	Sep. 22, 2020
WIT Standard Temperature And Humidity Chamber	TH-4S-C	W981030	Jun. 03, 2019	Jun. 02, 2020
Digital Multimeter Fluke	87-III	70360742	Jun. 28, 2019	Jun. 27, 2020
AC Power Supply Extech	CFW-105	E000603	NA	NA

Note: 1. The calibration interval of the above test instruments is 12 months and the calibrations are traceable to NML/ROC and NIST/USA.

4.6.4 Test Procedure

- The EUT was placed inside the environmental test chamber and powered by nominal AC voltage.
- Turn the EUT on and couple its output to a spectrum analyzer.
- Turn the EUT off and set the chamber to the highest temperature specified.
- Allow sufficient time (approximately 30 min) for the temperature of the chamber to stabilize, turn the EUT on and measure the operating frequency after 2, 5, and 10 minutes.
- Repeat step d with every 10 degrees reduction until the lowest temperature achieved.
- The test chamber was allowed to stabilize at +20 degree C for a minimum of 30 minutes. The supply voltage was then adjusted on the EUT from 85% to 115% and the frequency record.

4.6.5 Deviation from Test Standard

No deviation.

4.6.6 EUT Operating Condition

Set the EUT transmit at un-modulation mode to test frequency stability.

4.6.7 Test Results

Frequency Stability Versus Temp.									
Operating Frequency: 5180MHz									
Temp. (°C)	Power Supply (Vac)	0 Minute		2 Minute		5 Minute		10 Minute	
		Measured Frequency (MHz)	Result	Measured Frequency (MHz)	Result	Measured Frequency (MHz)	Result	Measured Frequency (MHz)	Result
50	120	5180.0159	Pass	5180.0169	Pass	5180.0171	Pass	5180.0161	Pass
40	120	5179.9736	Pass	5179.9747	Pass	5179.977	Pass	5179.9742	Pass
30	120	5180.0025	Pass	5180.0006	Pass	5180.0014	Pass	5180.0048	Pass
20	120	5179.9721	Pass	5179.9748	Pass	5179.9729	Pass	5179.9724	Pass
10	120	5180.0047	Pass	5180.0016	Pass	5180.0012	Pass	5180.0038	Pass
0	120	5179.9858	Pass	5179.987	Pass	5179.9858	Pass	5179.9873	Pass
-10	120	5179.9987	Pass	5179.9968	Pass	5179.9995	Pass	5180.001	Pass
-20	120	5180.0167	Pass	5180.0203	Pass	5180.019	Pass	5180.0169	Pass
-30	120	5180.005	Pass	5180.0048	Pass	5180.0059	Pass	5180.0044	Pass

Frequency Stability Versus Voltage									
Operating Frequency: 5180MHz									
Temp. (°C)	Power Supply (Vac)	0 Minute		2 Minute		5 Minute		10 Minute	
		Measured Frequency (MHz)	Result	Measured Frequency (MHz)	Result	Measured Frequency (MHz)	Result	Measured Frequency (MHz)	Result
20	138	5179.9718	Pass	5179.9742	Pass	5179.9719	Pass	5179.9717	Pass
	120	5179.9721	Pass	5179.9748	Pass	5179.9729	Pass	5179.9724	Pass
	102	5179.9714	Pass	5179.9744	Pass	5179.9723	Pass	5179.972	Pass

4.7 6dB Bandwidth Measurement

4.7.1 Limits of 6dB Bandwidth Measurement

The minimum of 6dB Bandwidth Measurement is 0.5MHz.

4.7.2 Test Setup

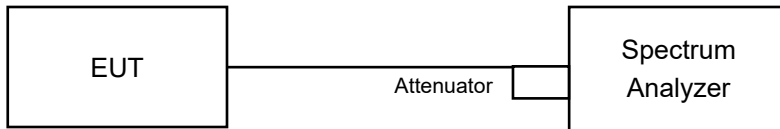

4.7.3 Test Instruments

Refer to section 4.1.2 to get information of above instrument.

4.7.4 Test Procedure

- Set resolution bandwidth (RBW) = 100kHz
- Set the video bandwidth (VBW) $\geq 3 \times$ RBW, Detector = Peak.
- Trace mode = max hold.
- Sweep = auto couple.
- Measure the maximum width of the emission that is constrained by the frequencies associated with the two amplitude points (upper and lower) that are attenuated by 6 dB relative to the maximum level measured in the fundamental emission

4.7.5 Deviation from Test Standard

No deviation.

4.7.6 EUT Operating Condition

The software provided by client to enable the EUT under transmission condition continuously at lowest, middle and highest channel frequencies individually.

4.7.7 Test Results

802.11a

Channel	Frequency (MHz)	6dB Bandwidth (MHz)		Minimum Limit (MHz)	Pass / Fail
		Chain 0	Chain 1		
149	5745	15.15	15.15	0.5	Pass
157	5785	15.18	15.17	0.5	Pass
165	5825	15.17	15.18	0.5	Pass

802.11ax (HE20)

Channel	Frequency (MHz)	6dB Bandwidth (MHz)		Minimum Limit (MHz)	Pass / Fail
		Chain 0	Chain 1		
149	5745	16.38	16.92	0.5	Pass
157	5785	17.05	17.58	0.5	Pass
165	5825	17.67	15.61	0.5	Pass

802.11ax (HE40)

Channel	Frequency (MHz)	6dB Bandwidth (MHz)		Minimum Limit (MHz)	Pass / Fail
		Chain 0	Chain 1		
151	5755	36.35	35.27	0.5	Pass
159	5795	35.63	35.22	0.5	Pass

802.11ax (HE80)

Channel	Frequency (MHz)	6dB Bandwidth (MHz)		Minimum Limit (MHz)	Pass / Fail
		Chain 0	Chain 1		
155	5775	75.48	75.33	0.5	Pass

Spectrum Plot of Worst Value

802.11a

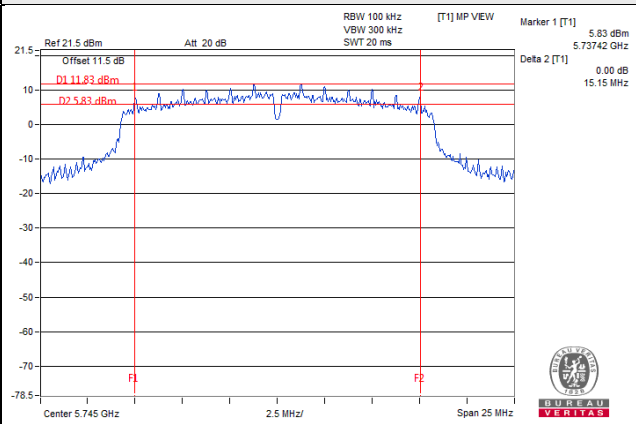

802.11ax (HE20)

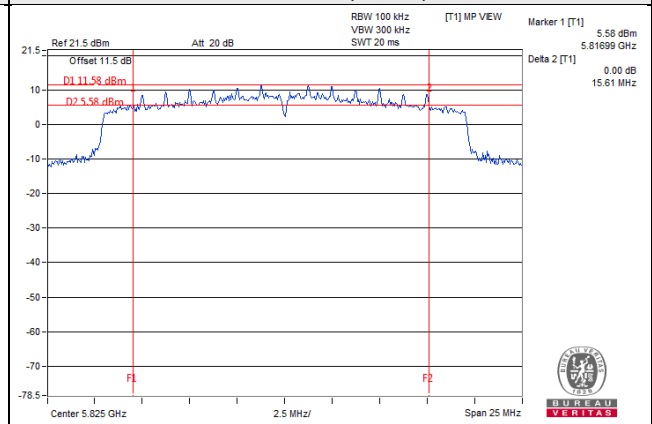

802.11ax (HE40)

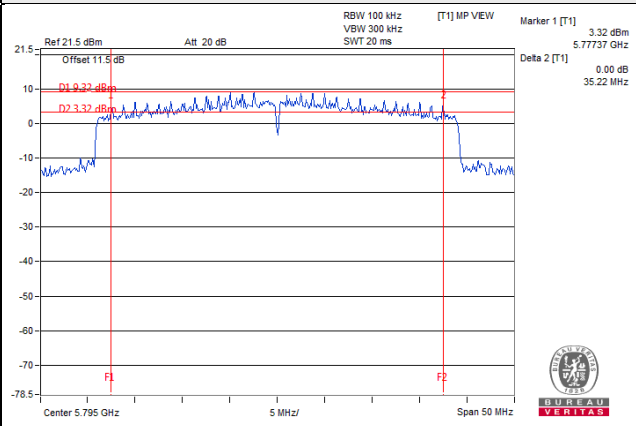

802.11ax (HE80)

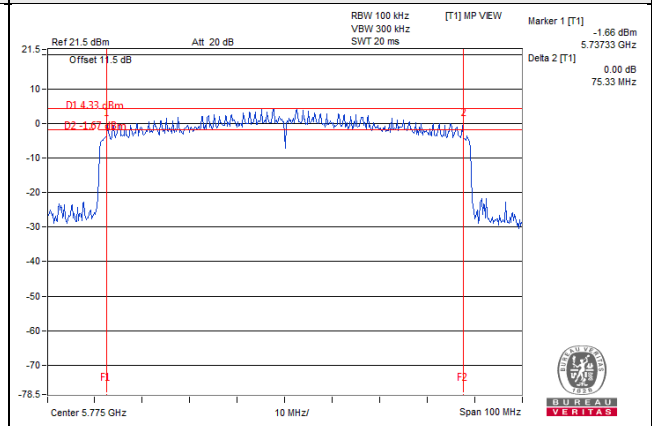

5 Pictures of Test Arrangements

Please refer to the attached file (Test Setup Photo).

Annex A- Radiated Out of Band Emission (OOBE) Measurement (For U-NII-3 band)

802.11a

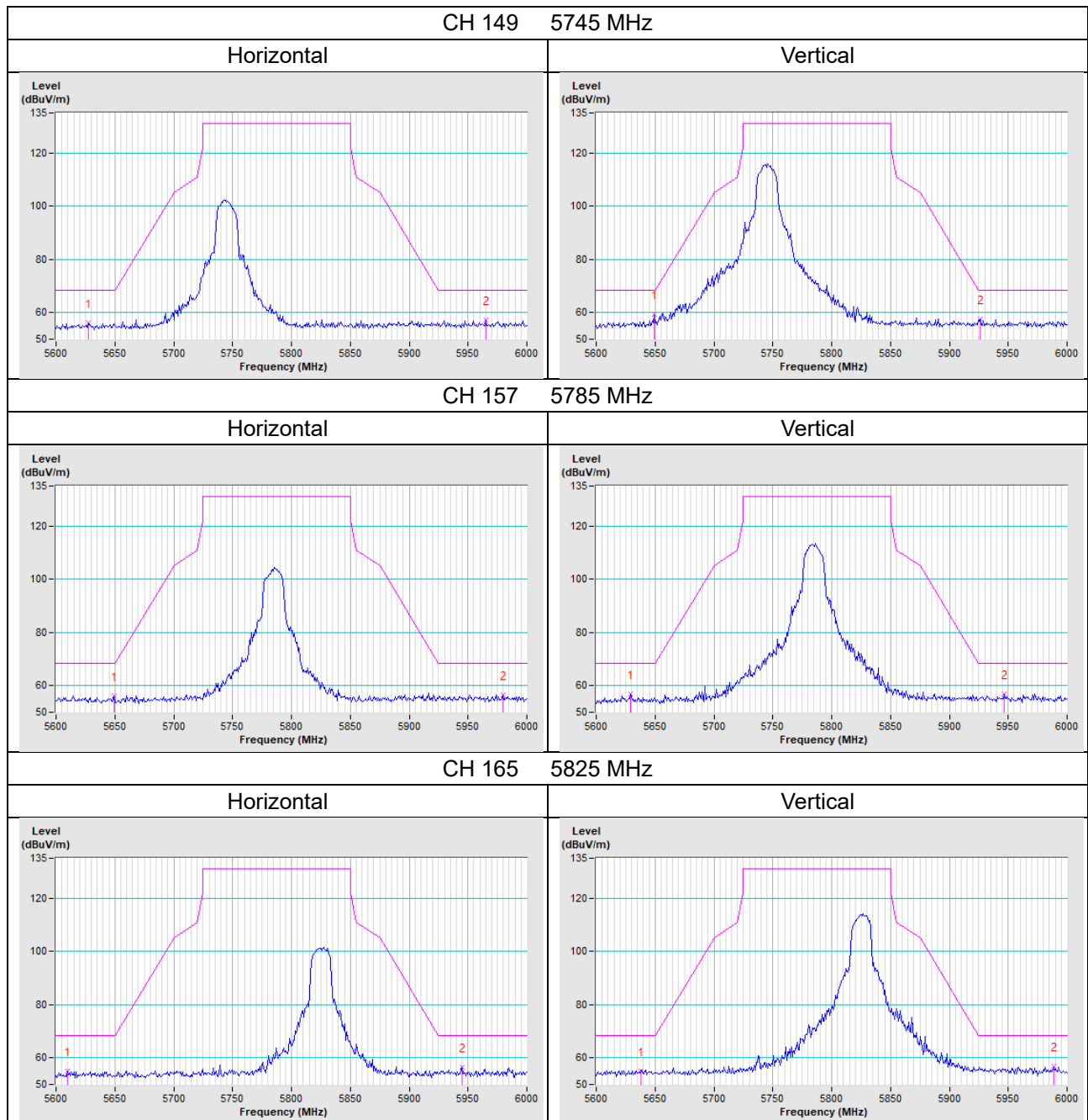

802.11n (HE20)

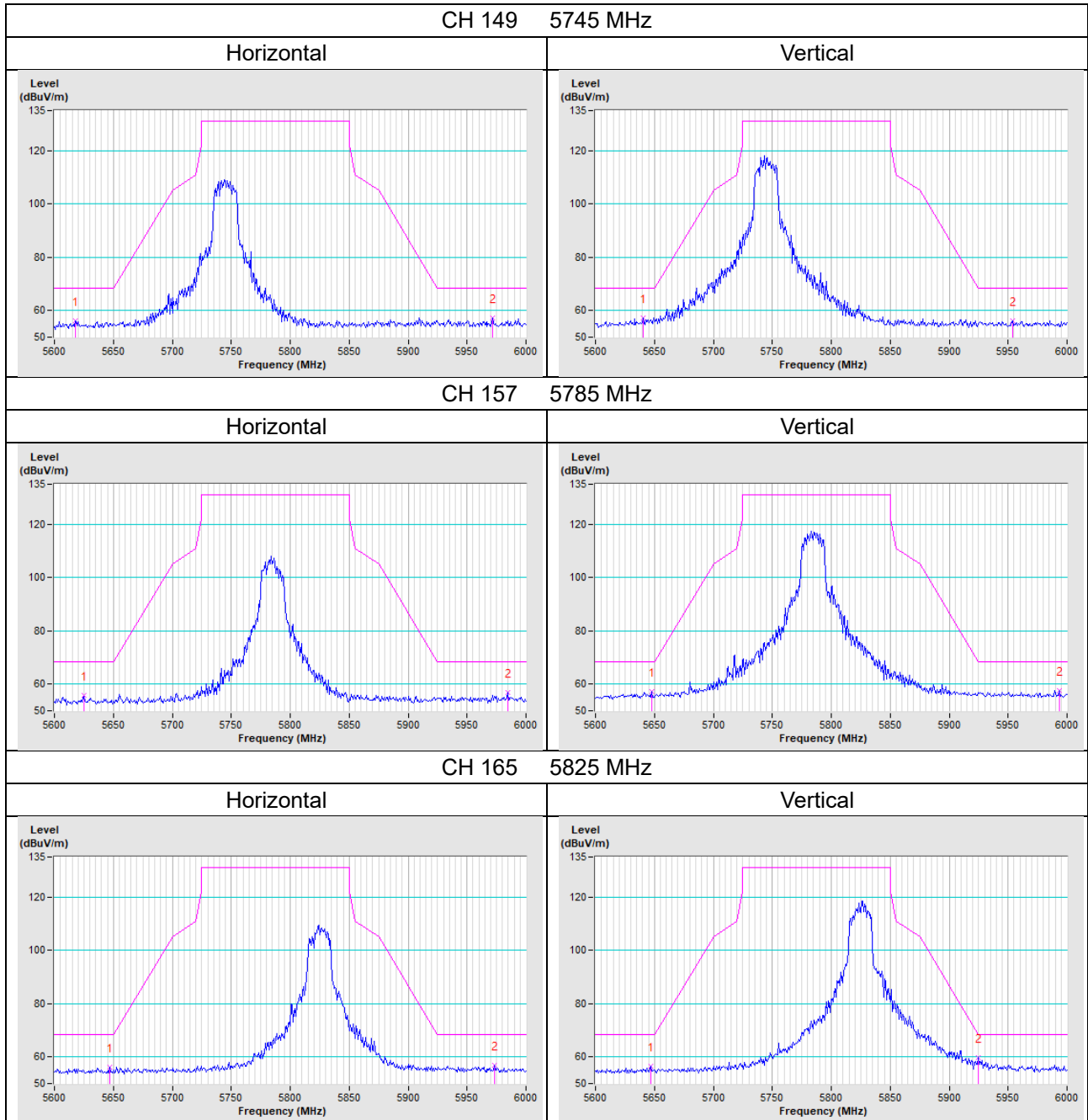

802.11n (HE40)

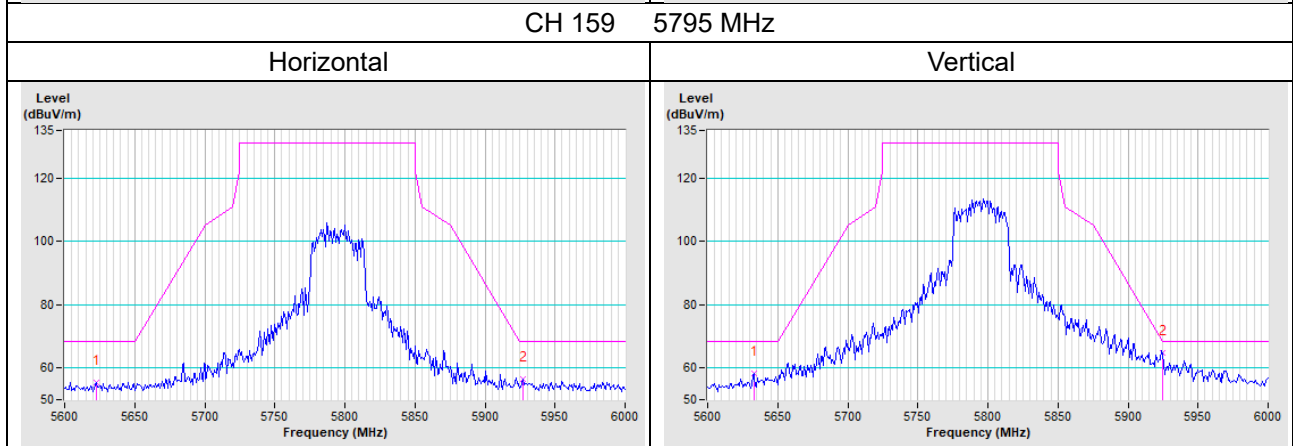
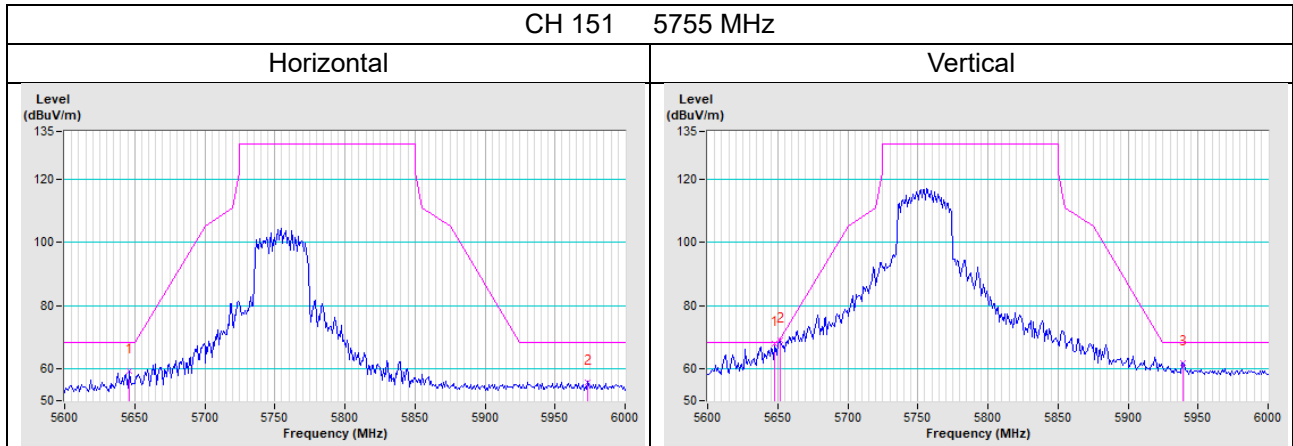

802.11n (HE80)

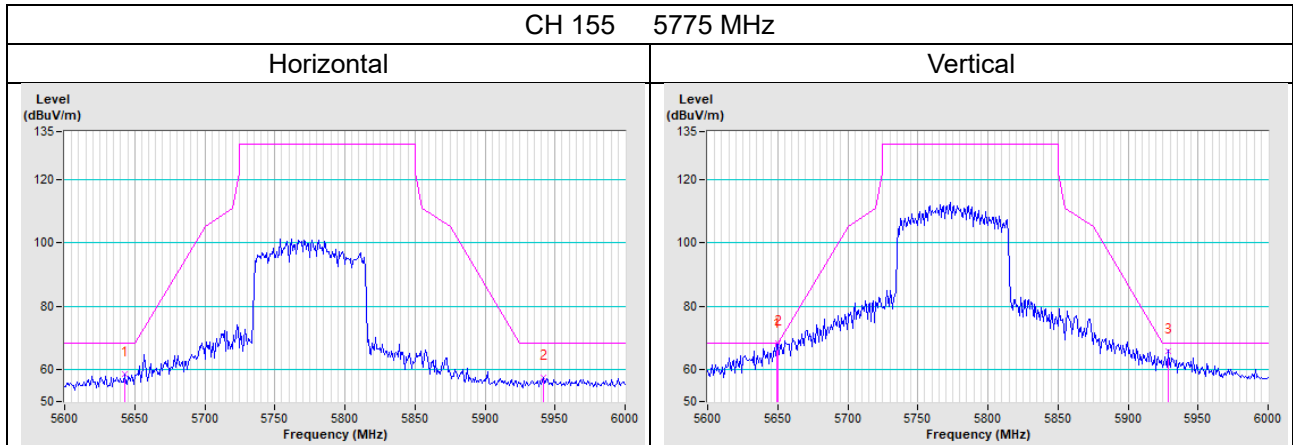

Appendix – Information of the Testing Laboratories

We, Bureau Veritas Consumer Products Services (H.K.) Ltd., Taoyuan Branch, were founded in 1988 to provide our best service in EMC, Radio, Telecom and Safety consultation. Our laboratories are FCC recognized accredited test firms and accredited and approved according to ISO/IEC 17025.

If you have any comments, please feel free to contact us at the following:

Lin Kou EMC/RF Lab

Tel: 886-2-26052180

Fax: 886-2-26051924

Hsin Chu EMC/RF/Telecom Lab

Tel: 886-3-6668565

Fax: 886-3-6668323

Hwa Ya EMC/RF/Safety

Tel: 886-3-3183232

Fax: 886-3-3270892

Email: service.adt@tw.bureauveritas.com

Web Site: www.bureauveritas-adt.com

The address and road map of all our labs can be found in our web site also.

--- END ---