



FCC 47 CFR PART 15 SUBPART C AND ANSI C63.4:2003 TEST REPORT

For

Product Name	Model Number
Wireless N600 Cloud VPN Router	DIR-840L
Wireless N600 VPN Router	DIR-840

Trade Name : **D-Link**

Issued for

D-Link Corporation

No.289 , Sinhu 3rd Rd. , Neihu District , Taipei City 114 , Taiwan R.O.C.

Issued by

Compliance Certification Services Inc.

Tainan Lab.

No.8,Jiucengling, Xinhua Dist., Tainan City 712, Taiwan (R.O.C.)

TEL: 886-6-580-2201

FAX: 886-6-580-2202

Issued Date: August 18, 2012



Note: This report shall not be reproduced except in full, without the written approval of Compliance Certification Services Inc. This document may be altered or revised by Compliance Certification Services Inc. personnel only, and shall be noted in the revision section of the document. The client should not use it to claim product endorsement by TAF or any government agencies. The test results of this report relate only to the tested sample identified in this report.



Revision History

Rev.	Issue Date	Revisions	Effect Page	Revised By
00	August 18, 2012	Initial Issue	ALL	Sunny Chang



TABLE OF CONTENTS

TITLE	PAGE NO.
1. TEST REPORT CERTIFICATION	4
2. EUT DESCRIPTION	5
3. DESCRIPTION OF TEST MODES	7
4. TEST METHODOLOGY	9
5. FACILITIES AND ACCREDITATION	9
5.1 FACILITIES	9
5.2 ACCREDITATIONS.....	9
5.3 MEASUREMENT UNCERTAINTY	10
6. SETUP OF EQUIPMENT UNDER TEST.....	11
7. FCC PART 15.247 REQUIREMENTS	15
7.1 6dB BANDWIDTH	15
7.2 MAXIMUM PEAK OUTPUT POWER	40
7.3 POWER SPECTRAL DENSITY	91
7.4 CONDUCTED SPURIOUS EMISSION	117
7.6 RADIATED EMISSION.....	146
7.7 CONDUCTED EMISSION.....	192
APPENDIX I MAXIMUM PERMISSIBLE EXPOSURE	203
APPENDIX II SETUP PHOTOS	206



1. TEST REPORT CERTIFICATION

Applicant : D-Link Corporation

Address : No.289 , Sinhu 3rd Rd. , Neihu District , Taipei City 114 , Taiwan
R.O.C.

Manufacturer : Advance Multimedia Internet Technology Inc.

Address : No.28, Lane 31 , Sec. 1 , Huandong Rd. , Sinshih District , Tainan
City 74146 , Taiwan

Equipment Under Test :	Product Name	Model Number
	(1) Wireless N600 Cloud VPN Router	(1) DIR-840L
Model Number :	(2) Wireless N600 VPN Router	(2) DIR-840

Brand Name : 

Date of Test : July 23, 2012 ~ August 06, 2012

APPLICABLE STANDARD	
Standard	Test Result
FCC Part 15 Subpart C AND ANSI C63.4:2003	PASS

WE HEREBY CERTIFY THAT: The above equipment has been tested by Compliance Certification Services Inc., and found compliance with the requirements set forth in the technical standards mentioned above. The results of testing in this report apply only to the product/system, which was tested. Other similar equipment will not necessarily produce the same results due to production tolerance and measurement uncertainties.

Approved by:

Reviewed by:

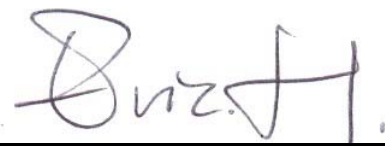
Jeter Wu
Assistant Manager

Eric Huang
Assistant Section Manager



2. EUT DESCRIPTION

Product Name	Product Name	Model Number
Model Number	(1) Wireless N600 Cloud VPN Router	(1) DIR-840L
	(2) Wireless N600 VPN Router	(2) DIR-840
Brand Name		
Identify Number	T120716N91	
Received Date	July 16, 2012	
Frequency Range	IEEE 802.11b/g, 802.11n HT20 : 2412MHz~2462MHz IEEE 802.11n HT40 : 2422MHz~2452MHz IEEE 802.11a, IEEE 802.11n HT20 : 5725MHz~5850MHz IEEE 802.11n HT40 : 5725MHz~5850MHz	
Transmit Power	IEEE 802.11b (2.4G) : 25.57 dBm IEEE 802.11g (2.4G) : 26.97 dBm IEEE 802.11n HT20 (2.4G) : 25.65 dBm IEEE 802.11n HT40 (2.4G) : 24.18 dBm IEEE 802.11a (5G) : 25.25 dBm IEEE 802.11n HT20 (5G) : 23.42 dBm IEEE 802.11n HT40 (5G) : 23.48 dBm	
Channel Spacing	IEEE 802.11b/g, 802.11n HT20/HT40 (2.4G) : 5MHz IEEE 802.11a, 802.11n HT20 (5G) : 20MHz IEEE 802.11n HT40 (5G) : 20MHz	
Channel Number	IEEE 802.11b/g, 802.11n HT20 (2.4G) : 11 Channels IEEE 802.11n HT40 (2.4G) : 7 Channels IEEE 802.11a, 802.11n HT20 (5G) : 4 Channels IEEE 802.11n HT40 (5G) : 4 Channels	
Transmit Data Rate	IEEE 802.11b (2.4G) : 11, 5.5, 2, 1 Mbps IEEE 802.11g (2.4G) : 54, 48, 36, 24, 18, 12, 9, 6 Mbps IEEE 802.11n HT20 (2.4G) : 130, 117, 104, 78, 65, 58.5, 52, 39, 26, 19.5, 13, 6.5 Mbps IEEE 802.11n HT40 (2.4G) : 300, 270, 243, 216, 162, 150, 135, 121.5, 108, 81, 54, 40.5, 27, 13.5 Mbps IEEE 802.11a (5G) : 54, 48, 36, 24, 18, 12, 9, 6 Mbps IEEE 802.11n HT20 (5G) : 130, 117, 104, 78, 65, 58.5, 52, 39, 26, 19.5, 13, 6.5 Mbps IEEE 802.11n HT40 (5G) : 300, 270, 243, 216, 162, 150, 135, 121.5, 108, 81, 54, 40.5, 27, 13.5 Mbps	



Type of Modulation	IEEE 802.11b (2.4G) : DSSS (CCK, DQPSK, DBPSK) IEEE 802.11g (2.4G) : OFDM (64QAM, 16QAM, QPSK, BPSK) IEEE 802.11n HT20/40 (2.4G) : OFDM (64QAM, 16QAM, QPSK, BPSK) IEEE 802.11a (5G) : OFDM (64QAM, 16QAM, QPSK, BPSK) IEEE 802.11n HT20/40 (5G) : OFDM (64QAM, 16QAM, QPSK, BPSK)
Antenna Type	Antenna (2TX2RX) Manufacture: WHA YU GROUP Type: Omni-directional antenna Model: C381-510190-A Gain: 2.4G: 3.0dBi 5G: 5.0dBi Connector: SMA plug straight / reverse
Power Rating	12Vdc; 2A(Powered from Adapter)
Power Source	Powered from adapter Adapter 1 Model: AMS4-1202000FU I/P: 100-240Vac, 50/60Hz, 0.8A O/P: 12Vdc, 2A Adapter 2 Model: UU324-1220 I/P: 100-240Vac, 50/60Hz, 0.6A O/P: 12Vdc, 2A
Test Voltage	120Vac, 60Hz

Remark :

1. Client consigns only one model sample to test (Model Number: DIR-840L).
2. The sample selected for test was engineering sample that approximated to production product and was provided by manufacturer.
3. For more details, please refer to the User's manual of the EUT.
4. This submittal(s) (test report) is intended for FCC ID: **KA2IR840LA1** filing to comply with Section 15.207, 15.209 and 15.247 of the FCC Part 15, Subpart C Rules.
5. To add a series model is for business necessary. The different of the each model is shown as below:

Model	Function
DIR-840L	With USB port (Connector 3G/LTE Dongle or NAS)
DIR-840	Without USB port



3. DESCRIPTION OF TEST MODES

Conducted Emission / Radiated Emission Test (Below 1 GHz)

1. The following test modes were scanned during the preliminary test:

No.	Pre-Test Mode
1	TX Mode

2. After the preliminary scan, the following test mode was found to produce the highest emission level.

Final Test Mode		
Emission	Radiated Emission	TX Mode
	Conducted Emission	TX Mode

Remark : Then, the above highest emission mode of the configuration of the EUT and cable was chosen for all final test items.

Conducted / Radiated Emission Test (Above 1 GHz)

IEEE 802.11b, 802.11g, 802.11n HT20 mode

The EUT had been tested under operating condition.

There are three channels have been tested as following :

Channel	Frequency (MHz)
Low	2412
Middle	2437
High	2462

IEEE 802.11b mode : 1Mbps data rate (worst case) were chosen for full testing.

IEEE 802.11g mode : 6Mbps data rate (worst case) were chosen for full testing.

IEEE 802.11n HT20 mode : 13Mbps data rate (worst case) were chosen for full testing.

IEEE 802.11n HT40 mode

The EUT had been tested under operating condition.

There are three channels have been tested as following :

Channel	Frequency (MHz)
Low	2422
Middle	2437
High	2452

IEEE 802.11n HT40 mode : 27Mbps data rate (worst case) were chosen for full testing.

While all conducted test the spectrum / power meter was connected to the Booster RF-out for 2.4GHz and the chain 1 of WiFi module for 5GHz.



IEEE 802.11a, 802.11n HT20 mode

The EUT had been tested under operating condition.

There are three channels have been tested as following :

Channel	Frequency (MHz)
Low	5745
Middle	5765
High	5805

IEEE 802.11a mode : 6Mbps data rate (worst case) were chosen for full testing.

IEEE 802.11n HT20 mode : 13Mbps data rate (worst case) were chosen for full testing.

IEEE 802.11n HT40 mode

The EUT had been tested under operating condition.

There are three channels have been tested as following :

Channel	Frequency (MHz)
Low	5745
Middle	5765
High	5805

IEEE 802.11n HT40 mode : 27Mbps data rate (worst case) were chosen for full testing.



4. TEST METHODOLOGY

The tests documented in this report were performed in accordance with ANSI C63.4: 2003 and FCC CFR 47, 15.207, 15.209 and 15.247.

5. FACILITIES AND ACCREDITATION

5.1 FACILITIES

All measurement facilities used to collect the measurement data are located at No.8, Jiucengling, Xinhua Dist., Tainan City 712, Taiwan (R.O.C.)

The sites are constructed in conformance with the requirements of ANSI C63.7, ANSI C63.4 and CISPR Publication 22.

5.2 ACCREDITATIONS

Our laboratories are accredited and approved by the following accreditation body according to ISO/IEC 17025.

Taiwan	TAF
---------------	-----

The measuring facility of laboratories has been authorized or registered by the following approval agencies.

Canada	Industry Canada
---------------	-----------------

Germany	TUV NORD
----------------	----------

Taiwan	BSMI
---------------	------

USA	FCC
------------	-----

Copies of granted accreditation certificates are available for downloading from our web site, <http://www.ccsrf.com>



5.3 MEASUREMENT UNCERTAINTY

The following table is for the measurement uncertainty, which is calculated as per the document CISPR 16-4-2.

PARAMETER	UNCERTAINTY
Radiated Emission, 30 to 200 MHz Test Site : OATS-6	±3.38dB
Radiated Emission, 200 to 1000 MHz Test Site : OATS-6	±3.04dB
Radiated Emission, 1 to 26.5 GHz	± 3.20dB
Power Line Conducted Emission	± 2.01dB

Uncertainty figures are valid to a confidence level of 95%, K=2



6. SETUP OF EQUIPMENT UNDER TEST

SUPPORT EQUIPMENT

For RF test

No.	Product	Manufacturer	Model No.	Certify No.	Signal cable
1	Note Book	IBM	T43	DoC	Power cable, unshd, 1.6m

No.	Signal cable description	
A	DC Power	Unshielded, 1.4m, 1pcs
B	LAN Cable	Unshielded, 10m, 1pcs

For EMI test

No.	Product	Manufacturer	Model No.	Certify No.	Signal cable
1	Note Book	IBM	T43	DoC	Power cable, unshd, 1.6m
2	Note Book	IBM	R50E	DoC	Power cable, unshd, 1.6m
3	Note Book	Acer	AS 3830TG	DoC	Power cable, unshd, 1.6m
4	3G Modem	NOVATEL	Qualcomm 3G CDMA	PKRNVWMC727	N/A
5	HUB	BARRICAD	SMC7008BR	DoC	Power cable, unshd, 1.6m

No.	Signal cable description	
A	DC Power	Unshielded, 1.4m, 1pcs
B	LAN	Unshielded, 10m, 1pcs
C	LAN	Unshielded, 2.0m, 3pcs
D	LAN	Unshielded, 10m, 1pcs



SETUP DIAGRAM FOR TESTS

For RF test

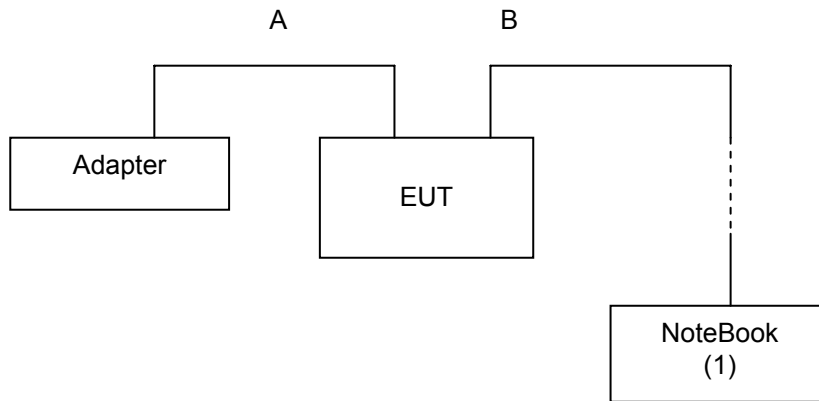

For EMI test

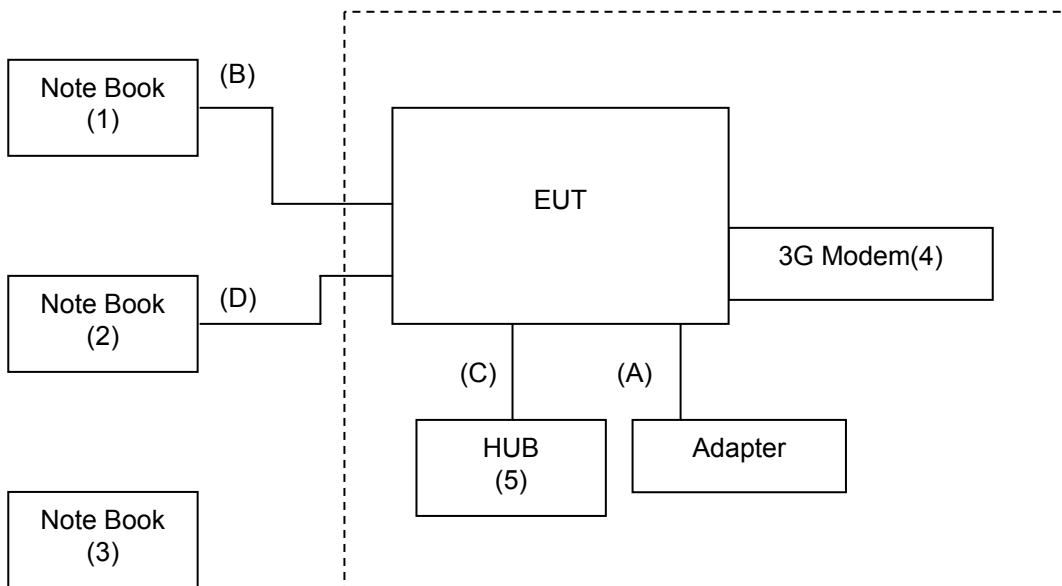



EUT OPERATING CONDITION

RF Setup (2.4G)

1. Set up all computers like the setup diagram.
2. The “Ralink QA Test Program for “RT3x9xQA” software was used for testing
The EUT driver software installed in the host support equipment during testing was Ralink QA Test Program for “RT3x9xQA” Drive

TX Mode:

- ⇒ **Tx Mode:CCK 、 OFDM 、 HT MixMode** (Bandwidth: 20 、 40)
- ⇒ **Tx Data Rate: 1Mbps long** (IEEE 802.11b mode , TX)
6Mbps (IEEE 802.11g mode , TX)
13Mbps (IEEE 802.11n HT20 mode ,chain 0, chain 1 TX)
27Mbps (IEEE 802.11n HT40 mode, chain 0, chain 1 TX)

Power control mode

- Target Power:** IEEE 802.11b Channel Low (2412MHz) =17
IEEE 802.11b Channel Middle (2437MHz) =19
IEEE 802.11b Channel High (2462MHz) = 1A
- Target Power:** IEEE 802.11g Channel Low (2412MHz) = 18
IEEE 802.11g Channel Middle (2437MHz) = 19
IEEE 802.11g Channel High (2462MHz) = 19
- Target Power:** IEEE 802.11n HT20 Channel Low (2412MHz) = 0E (**Chain 0**)
IEEE 802.11 n HT20 Channel Middle (2437MHz) =11 (**Chain 0**)
IEEE 802.11 n HT20 Channel High (2462MHz) = 13 (**Chain 0**)
IEEE 802.11n HT20 Channel Low (2412MHz) = 0E (**Chain 1**)
IEEE 802.11 n HT20 Channel Middle (2437MHz) = 11 (**Chain 1**)
IEEE 802.11 n HT20 Channel High (2462MHz) = 13 (**Chain 1**)
- Target Power:** IEEE 802.11n HT40 Channel Low (2422MHz) = 0F (**Chain 0**)
IEEE 802.11 n HT40 Channel Middle (2437MHz) = 11 (**Chain 0**)
IEEE 802.11 n HT40 Channel High (2452MHz) = 10 (**Chain 0**)
IEEE 802.11n HT40 Channel Low (2422MHz) = 0F (**Chain 1**)
IEEE 802.11 n HT40 Channel Middle (2437MHz) = 11(**Chain 1**)
IEEE 802.11 n HT40 Channel High (2452MHz) = 10 (**Chain 1**)

RX Mode :

MAC Address: FFFFFFFF

Start RX

3. All of the function are under run.
4. Start test.

Normal Link Setup

1. Set up all computers like the setup diagram.
2. All of the function are under run.
3. Notebook PC (2) ping 192.168.0.10 –t to Notebook PC (1).
4. Notebook PC (1) ping 192.168.0.20 –t to Notebook PC (2).
5. Notebook PC (1) ping 192.168.0.50 –t to Wireless Access Point (3).

Start test.



RF Setup (5G)

1. Set up all computers like the setup diagram.
2. The “Ralink QA Test Program for “RT5x9xQA_1.0.7.5” software was used for testing
The EUT driver software installed in the host support equipment during testing was Ralink QA Test Program for “RT5x9xQA_1.0.7.5” Drive

TX Mode:

- ⇒ **Tx Mode: OFDM 、 HT MixMode** (Bandwidth: 20 、 40)
- ⇒ **Tx Data Rate: 6Mbps** (IEEE 802.11a mode , TX)
13Mbps (IEEE 802.11n HT20 mode ,chain 0, chain 1 TX)
27Mbps (IEEE 802.11n HT40 mode, chain 0, chain 1 TX)

Power control mode

Target Power: IEEE 802.11a Higher Sub-Band Channel Low (5745MHz) = 0C (**Chain 0**)

IEEE 802.11a Higher Sub-Band Channel Middle (5765MHz) = 0C (**Chain 0**)

IEEE 802.11a Higher Sub-Band Channel High (5805MHz) = 0D (**Chain 0**)

Target Power: IEEE 802.11n HT20 Higher Sub-Band Channel Low (5745MHz) = 04 (**Chain 0**)

IEEE 802.11 n HT20 Higher Sub-Band Channel Middle (5765MHz) = 04 (**Chain 0**)

IEEE 802.11n HT20 Higher Sub-Band Channel High (5805MHz) = 06 (**Chain 0**)

IEEE 802.11n HT20 Higher Sub-Band Channel Low (5745MHz) = 04 (**Chain 1**)

IEEE 802.11 n HT20 Higher Sub-Band Channel Middle (5765MHz) = 04 (**Chain 1**)

IEEE 802.11n HT20 Higher Sub-Band Channel High (5805MHz) = 06 (**Chain 1**)

Target Power: IEEE 802.11n HT40 Higher Sub-Band Channel Low (5745MHz) = 04 (**Chain 0**)

IEEE 802.11 n HT40 Higher Sub-Band Channel Middle (5765MHz) = 04 (**Chain 0**)

IEEE 802.11n HT40 Higher Sub-Band Channel High (5805MHz) = 06 (**Chain 0**)

IEEE 802.11n HT40 Higher Sub-Band Channel Low (5745MHz) = 04 (**Chain 1**)

IEEE 802.11 n HT40 Higher Sub-Band Channel Middle (5765MHz) = 04 (**Chain 1**)

IEEE 802.11n HT40 Higher Sub-Band Channel High (5805MHz) = 06 (**Chain 1**)

RX Mode :

MAC Address: FFFFFFFF

Start RX

3. All of the function are under run.
4. Start test.

Normal Link Setup

6. Set up all computers like the setup diagram.
 7. All of the function are under run.
 8. Notebook PC (2) ping 192.168.0.10 –t to Notebook PC (1).
 9. Notebook PC (1) ping 192.168.0.20 –t to Notebook PC (2).
 10. Notebook PC (1) ping 192.168.0.50 –t to Wireless Access Point (3).
- Start test.



7. FCC PART 15.247 REQUIREMENTS

7.1 6dB BANDWIDTH

LIMITS

§ 15.247(a) (2) For direct sequence systems, the minimum 6dB bandwidth shall be at least 500kHz.

TEST EQUIPMENT

Name of Equipment	Manufacturer	Model	Serial Number	Calibration Due
Spectrum Analyzer	FSU	200789	---	SEP. 29, 2012

Remark: Each piece of equipment is scheduled for calibration once a year.

TEST SETUP

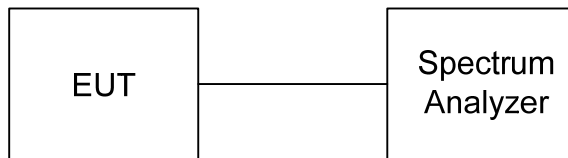

TEST PROCEDURE

1. Set resolution bandwidth (RBW) = 1-5 % of the emission bandwidth (EBW).
2. Set the video bandwidth (VBW) $\geq 3 \times$ RBW.
3. Detector = Peak.
4. Trace mode = max hold.
5. Sweep = auto couple.
6. Allow the trace to stabilize.
7. Measure the maximum width of the emission that is constrained by the frequencies associated with the two outermost amplitude points (upper and lower) that are attenuated by 6 dB relative to the maximum level measured in the fundamental emission. Compare the resultant bandwidth with the RBW setting of the analyzer. Readjust RBW and repeat measurement as needed until the RBW/EBW ratio is 1-5 %.



TEST RESULTS

IEEE 802.11b Mode

Channel	Channel Frequency (MHz)	6dB Bandwidth (kHz)	Minimum Limit (kHz)	Pass / Fail
Low	2412	12179.49	500	PASS
Middle	2437	12179.49	500	PASS
High	2462	12179.49	500	PASS

IEEE 802.11g Mode

Channel	Channel Frequency (MHz)	6dB Bandwidth (kHz)	Minimum Limit (kHz)	Pass / Fail
Low	2412	16346.15	500	PASS
Middle	2437	16346.15	500	PASS
High	2462	16346.15	500	PASS

IEEE 802.11n HT20 Mode

Channel	Channel Frequency (MHz)	6dB Bandwidth (kHz)		Minimum Limit (kHz)	Pass / Fail
		Chain 0	Chain1		
Low	2412	17500.00	17628.21	500	PASS
Middle	2437	17500.00	17628.21	500	PASS
High	2462	17500.00	17628.21	500	PASS

IEEE 802.11n HT40 Mode

Channel	Channel Frequency (MHz)	6dB Bandwidth (kHz)		Minimum Limit (kHz)	Pass / Fail
		Chain 0	Chain1		
Low	2422	36025.64	36025.64	500	PASS
Middle	2437	36025.64	36025.64	500	PASS
High	2452	36025.64	36025.64	500	PASS



IEEE 802.11a Mode

Channel	Channel Frequency (MHz)	6dB Bandwidth (kHz)	Minimum Limit (kHz)	Pass / Fail
Low	5745	16633	500	PASS
Middle	5765	16633	500	PASS
High	5805	16633	500	PASS

IEEE 802.11n HT20 Mode

Channel	Channel Frequency (MHz)	6dB Bandwidth (kHz)		Minimum Limit (kHz)	Pass / Fail
		Chain 0	Chain1		
Low	5745	17436	17628	500	PASS
Middle	5765	17436	17628	500	PASS
High	5805	17436	17628	500	PASS

IEEE 802.11n HT40 Mode

Channel	Channel Frequency (MHz)	6dB Bandwidth (kHz)		Minimum Limit (kHz)	Pass / Fail
		Chain 0	Chain1		
Low	5745	36154	36410	500	PASS
Middle	5765	36154	36282	500	PASS
High	5805	36103	36103	500	PASS



6dB BANDWIDTH (2.4G)

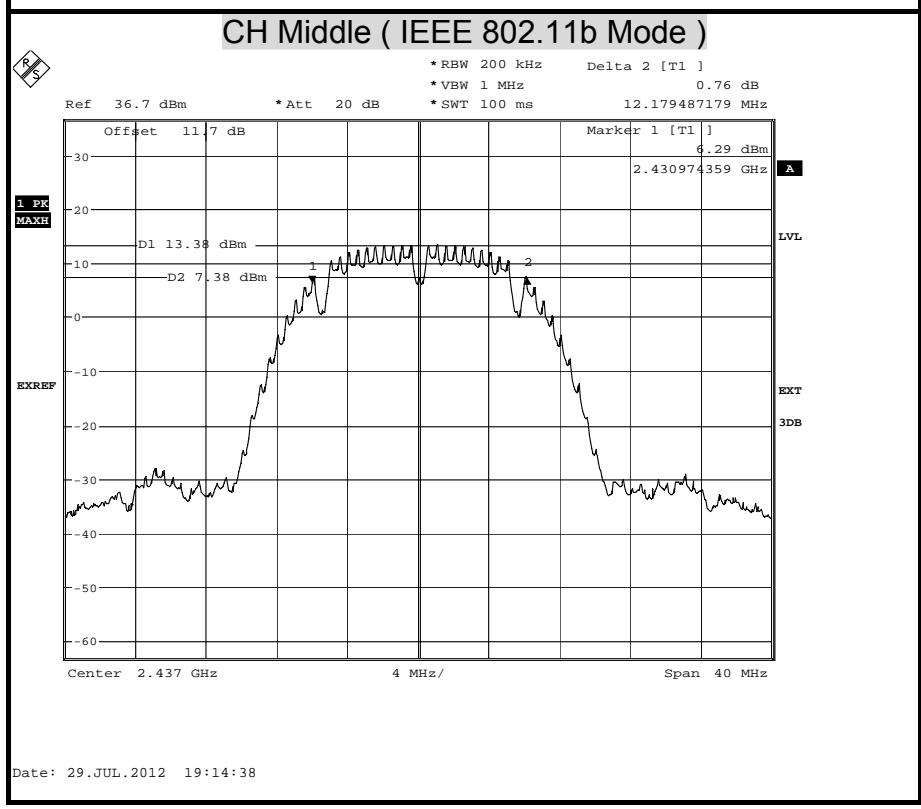
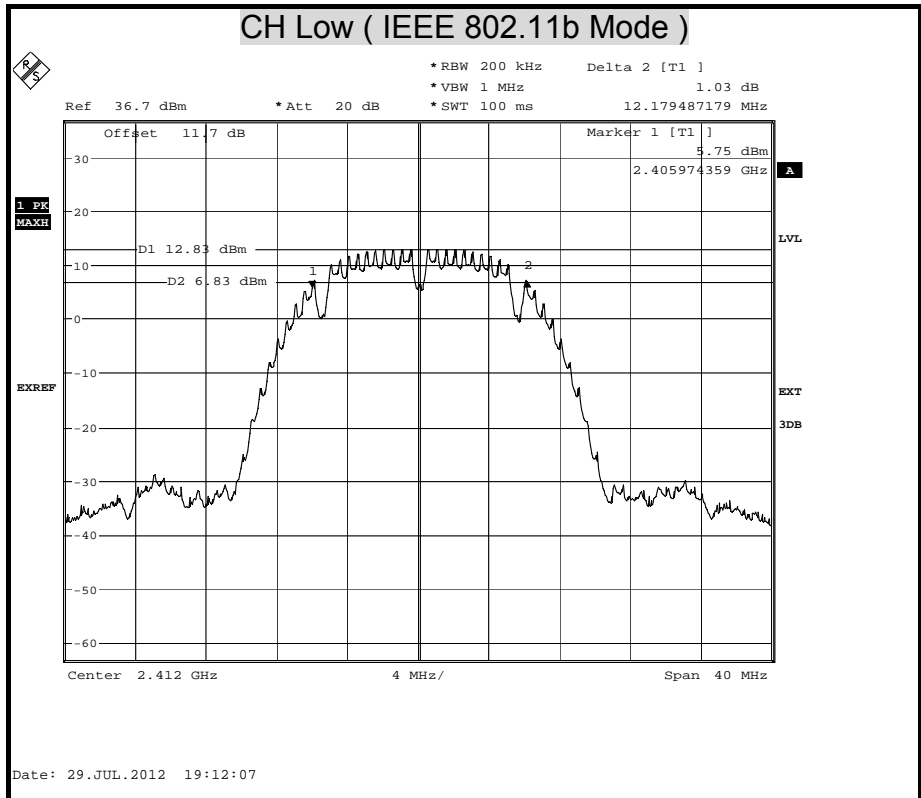

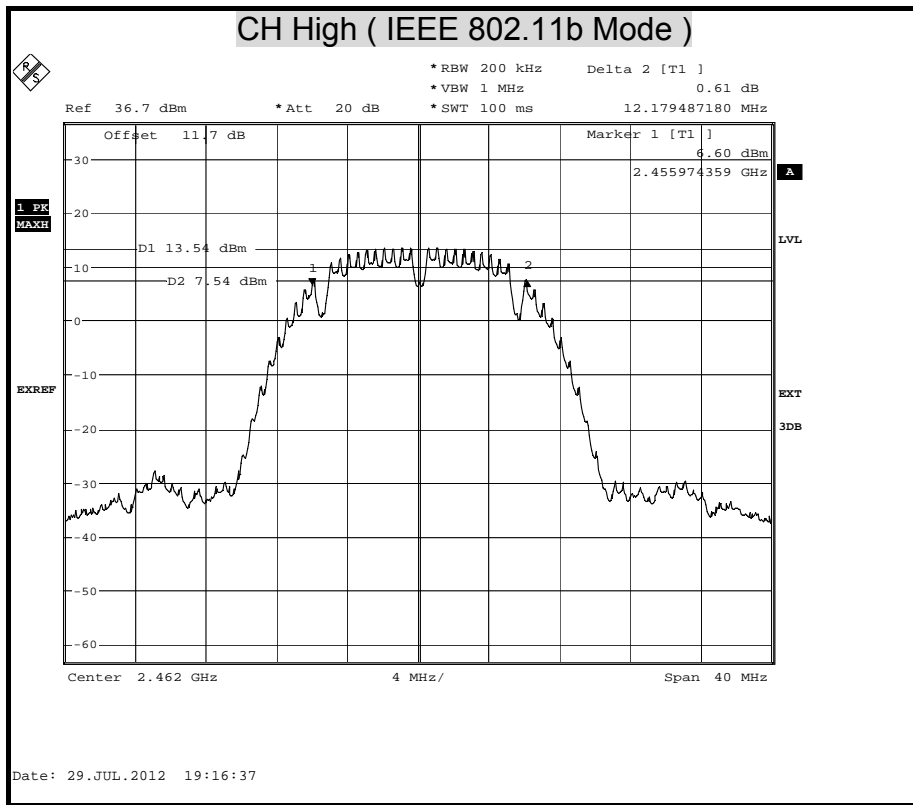

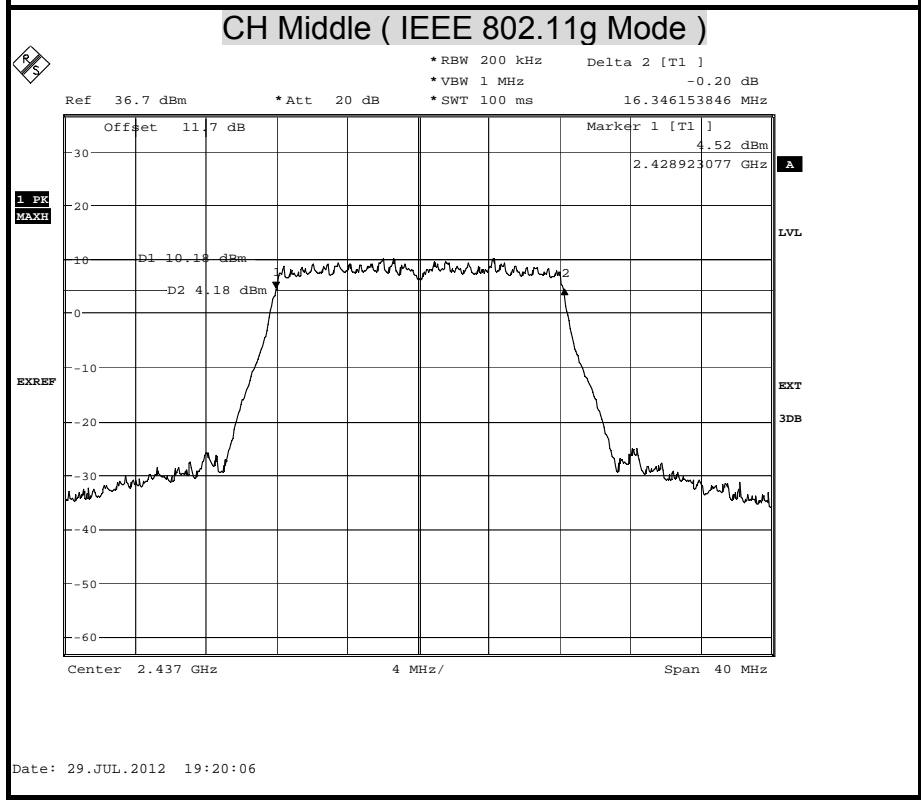
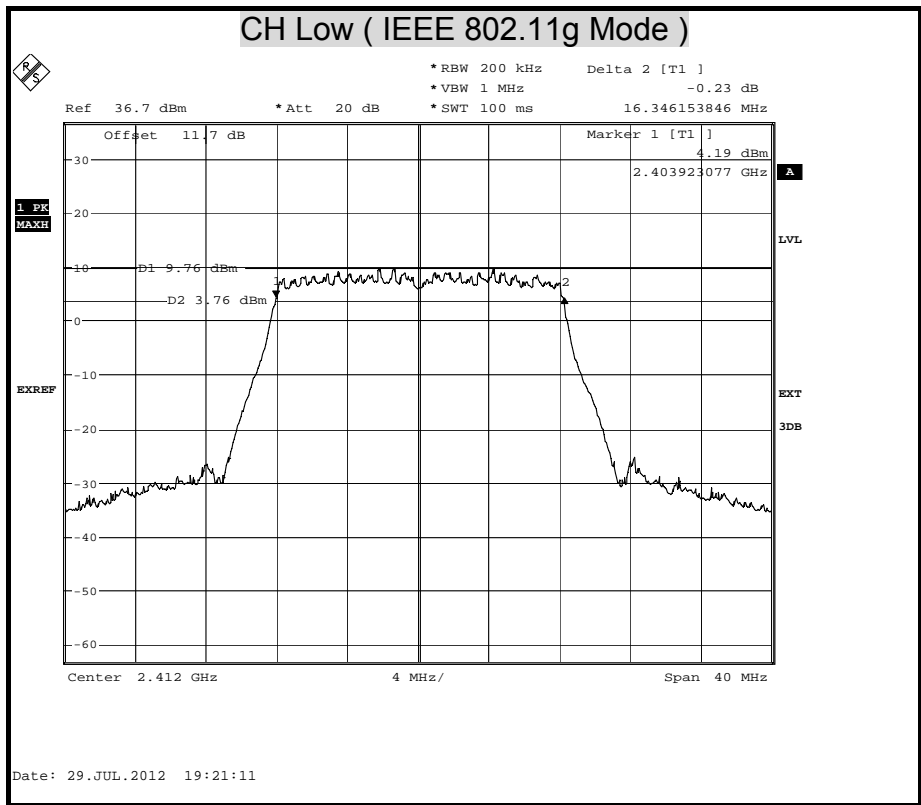

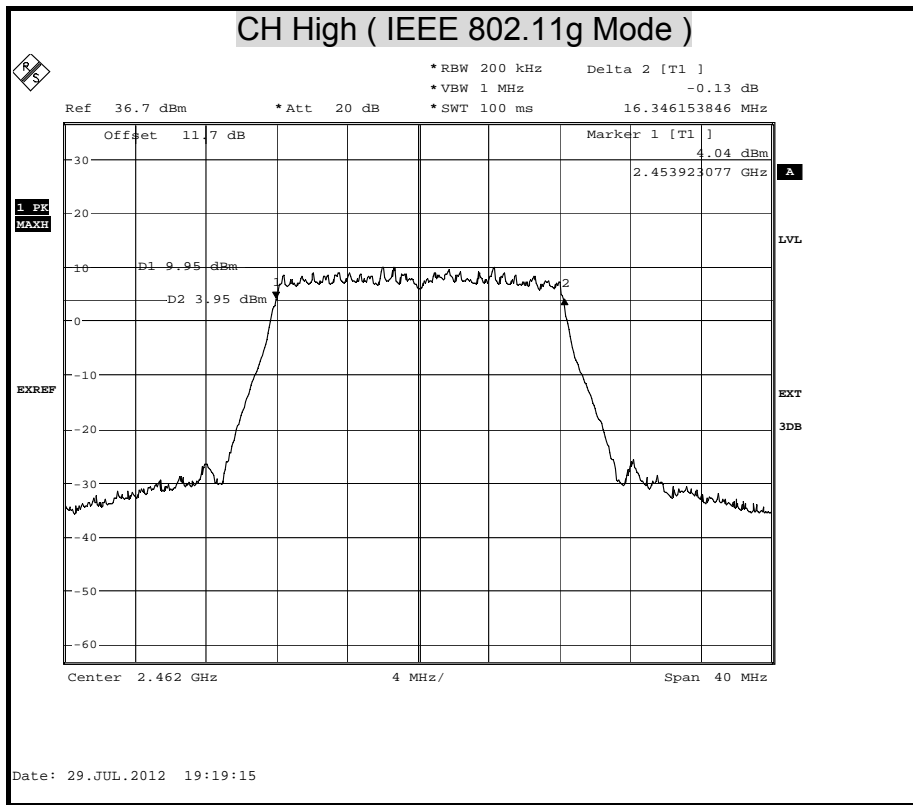

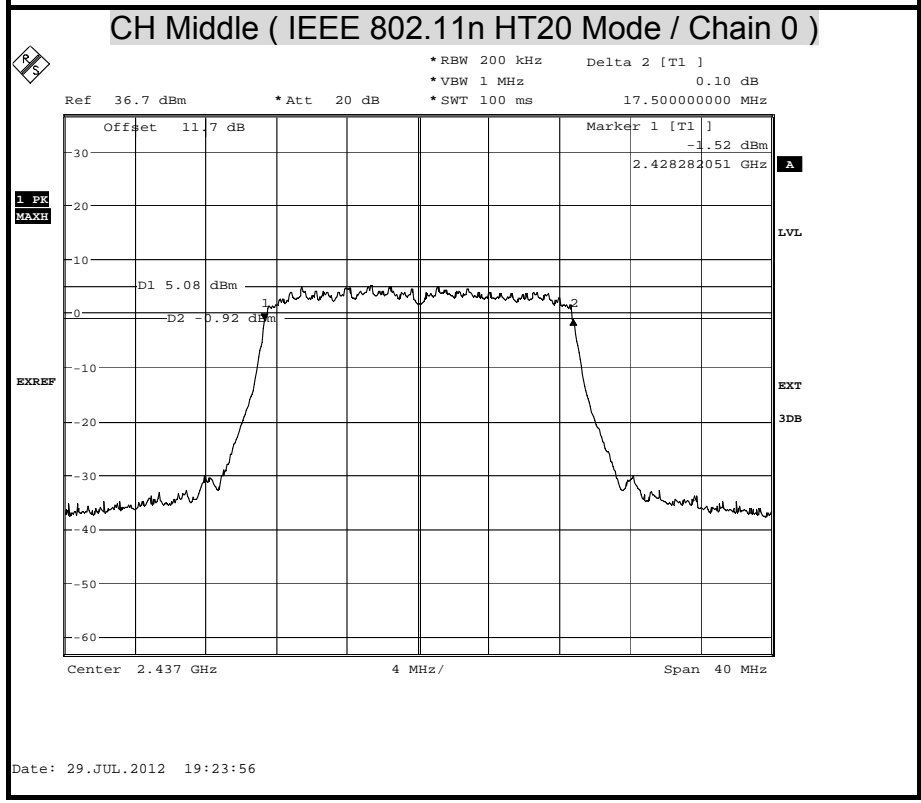
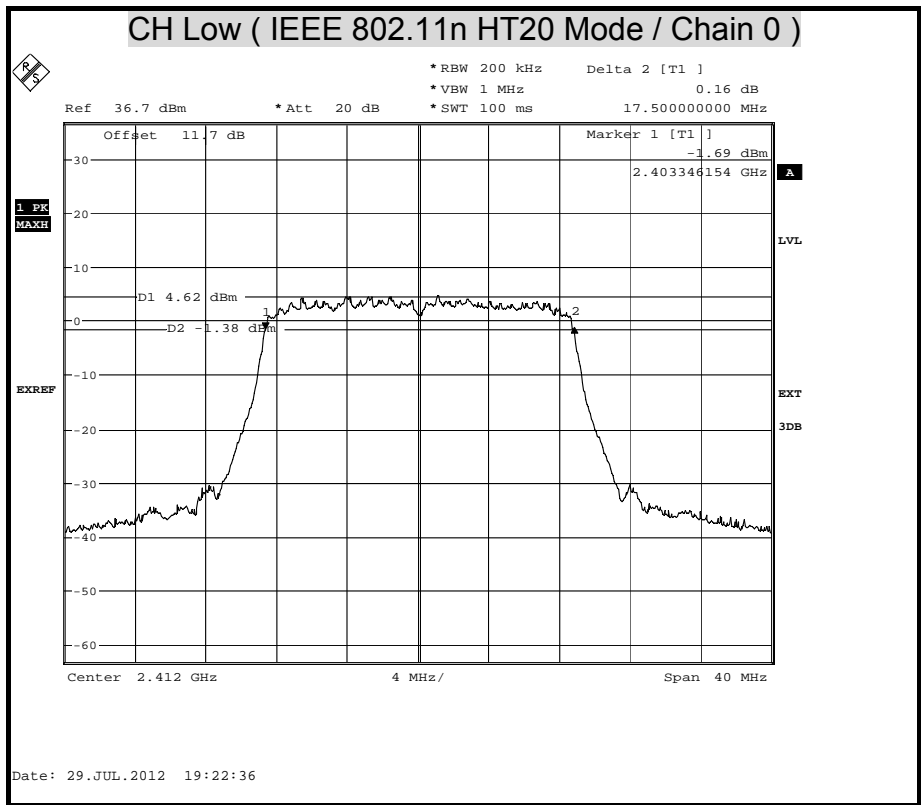

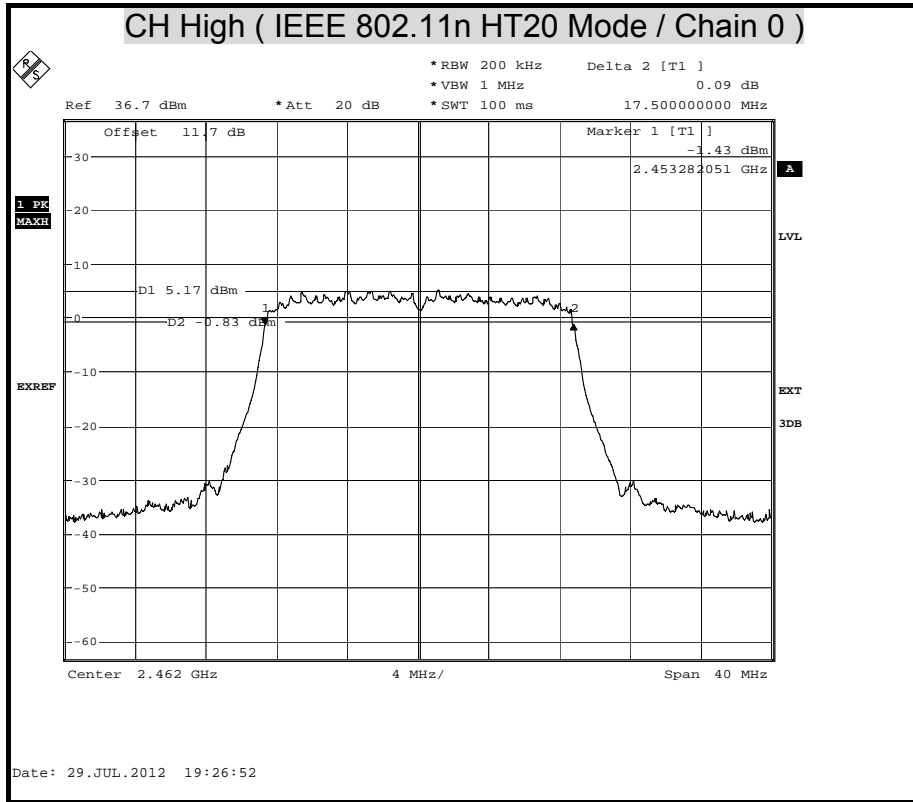

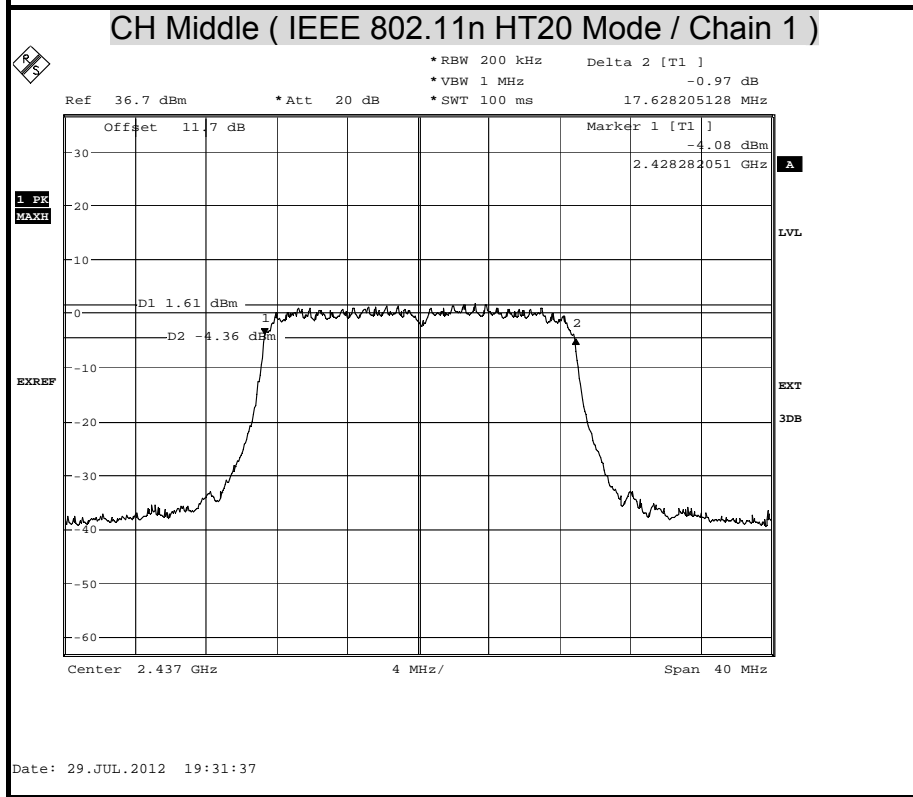
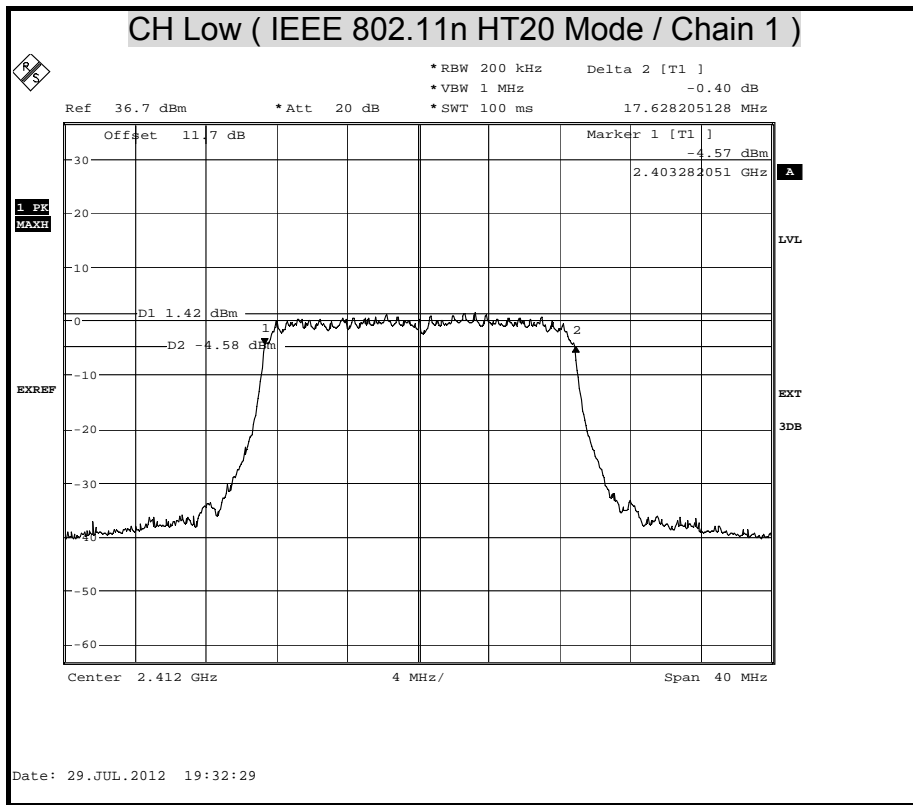

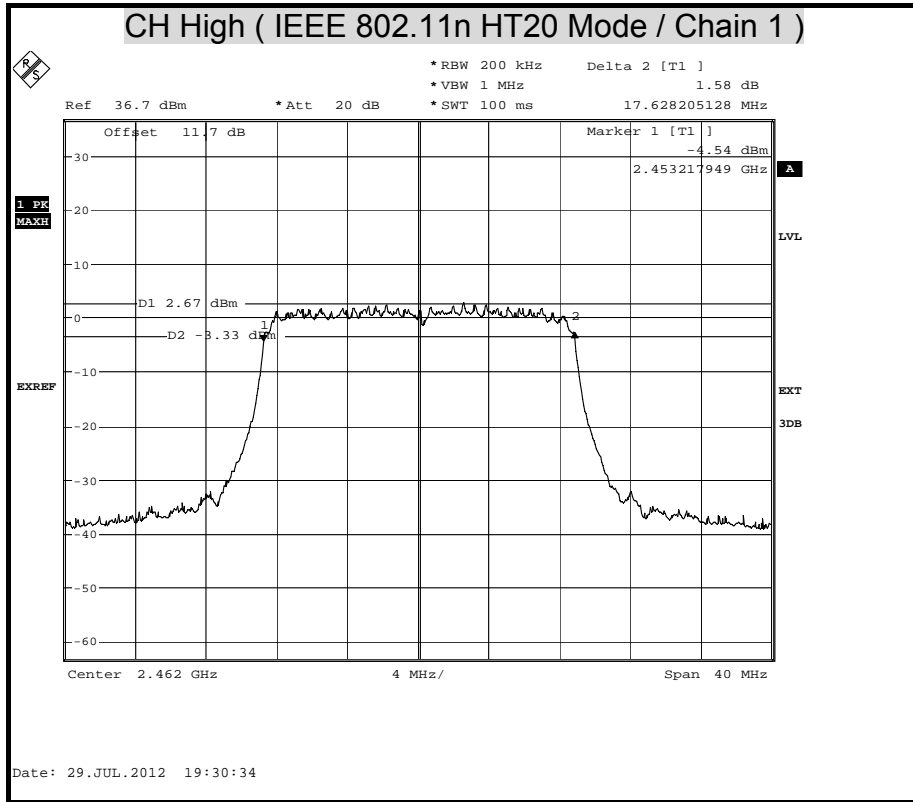

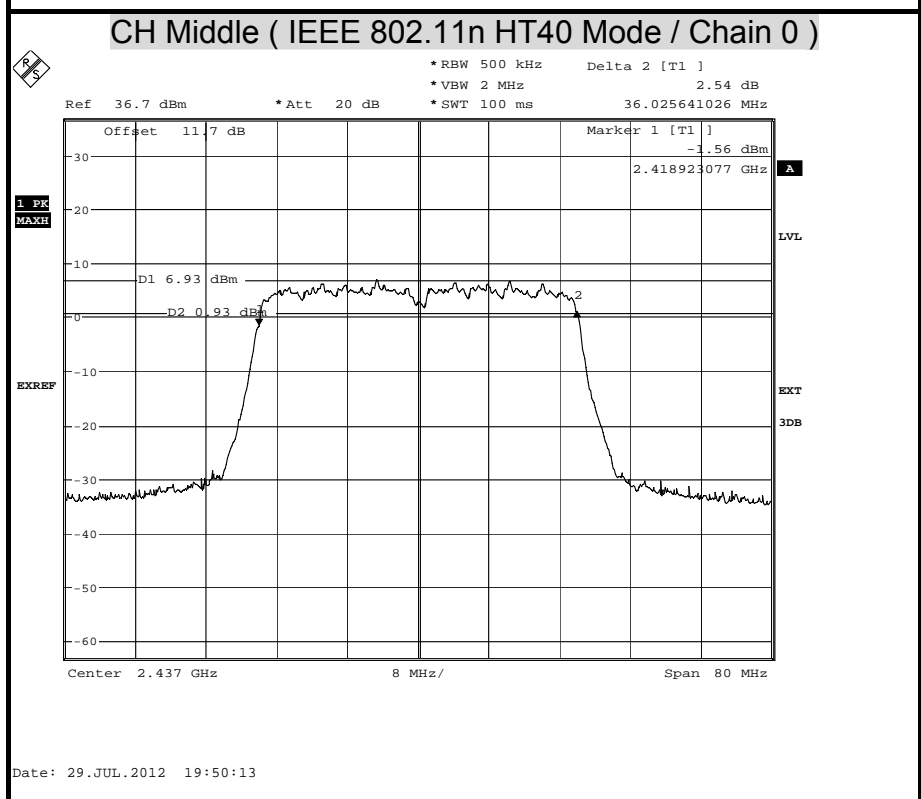
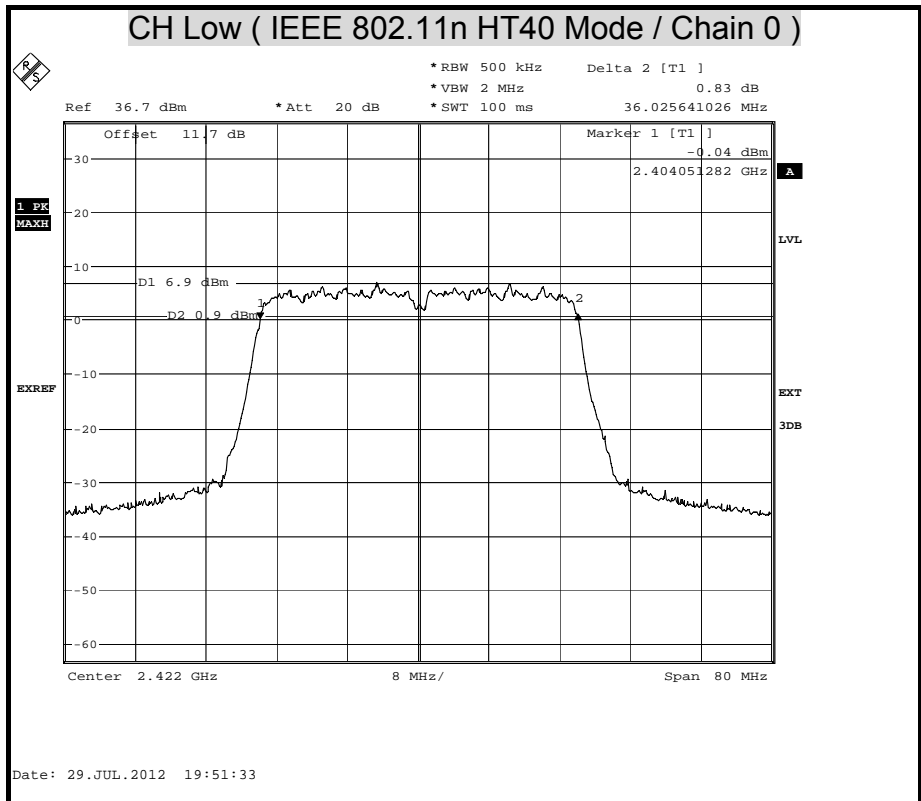

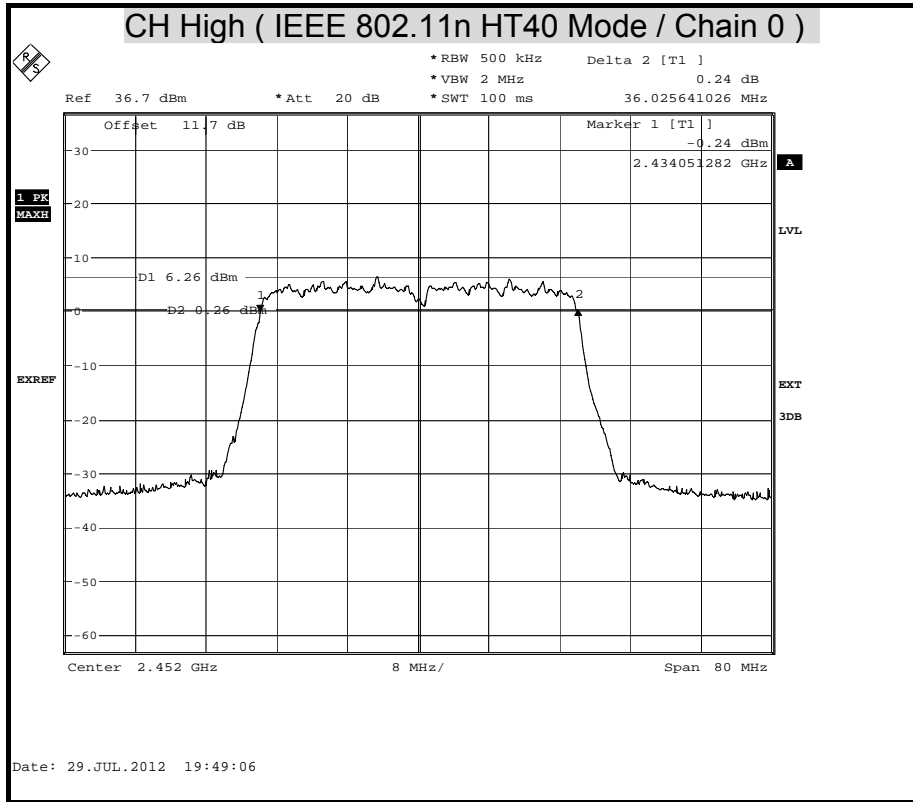

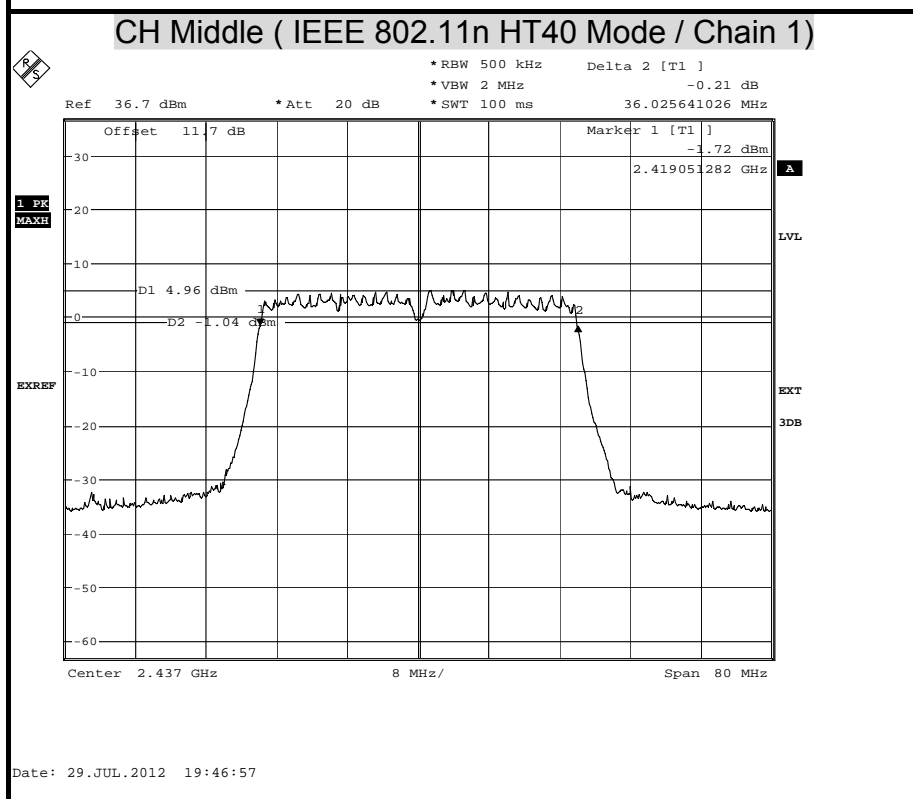
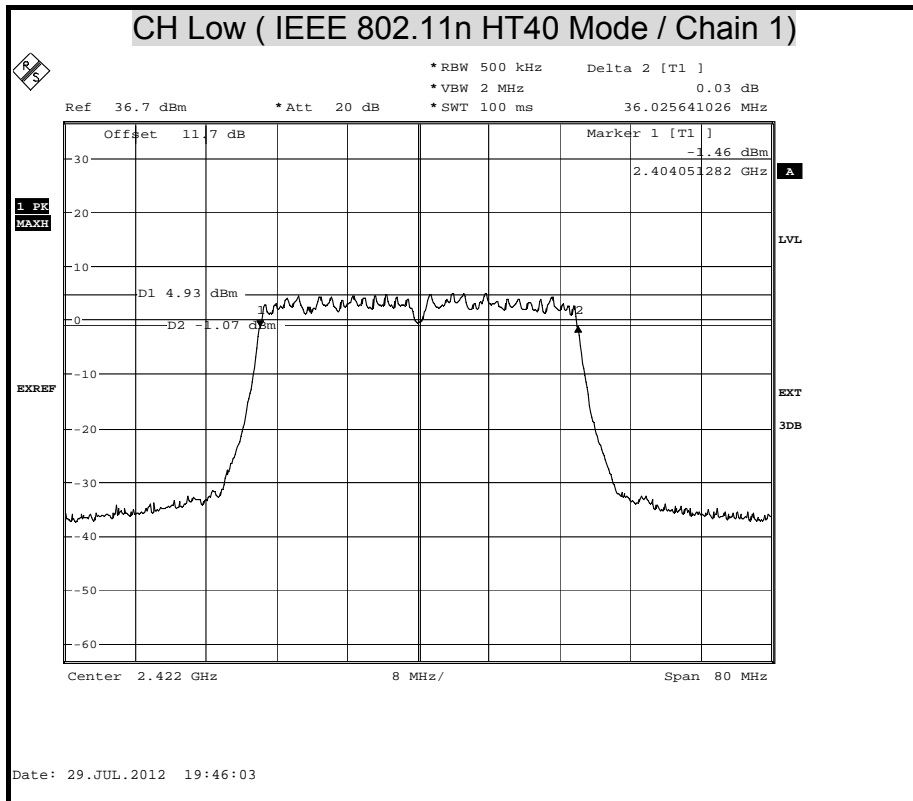

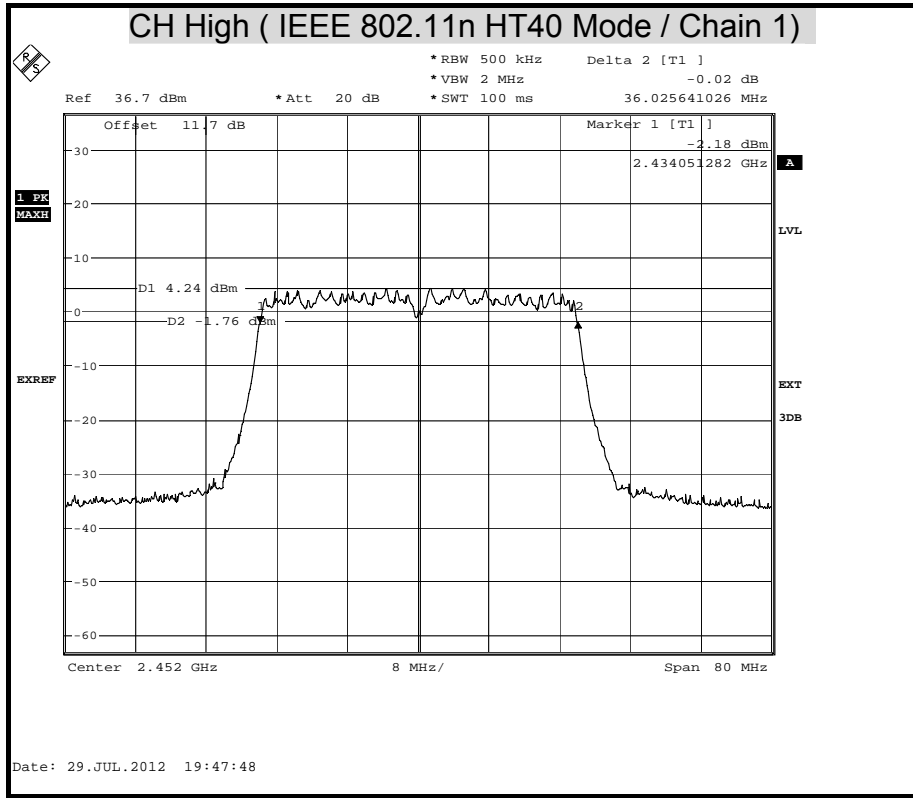



6dB BANDWIDTH (5G)

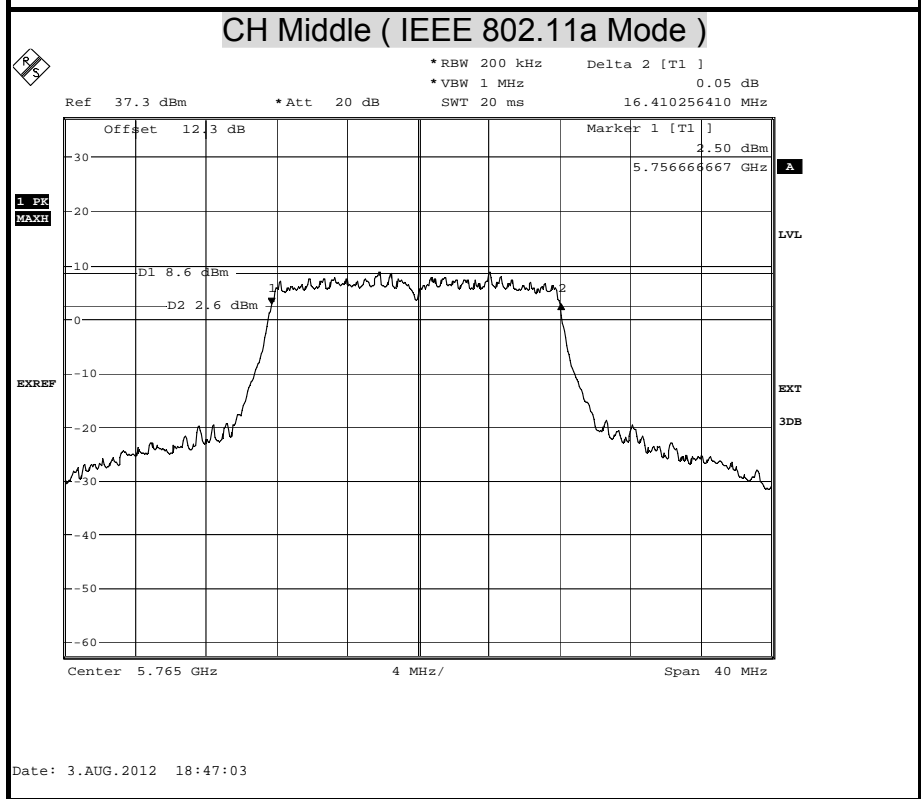
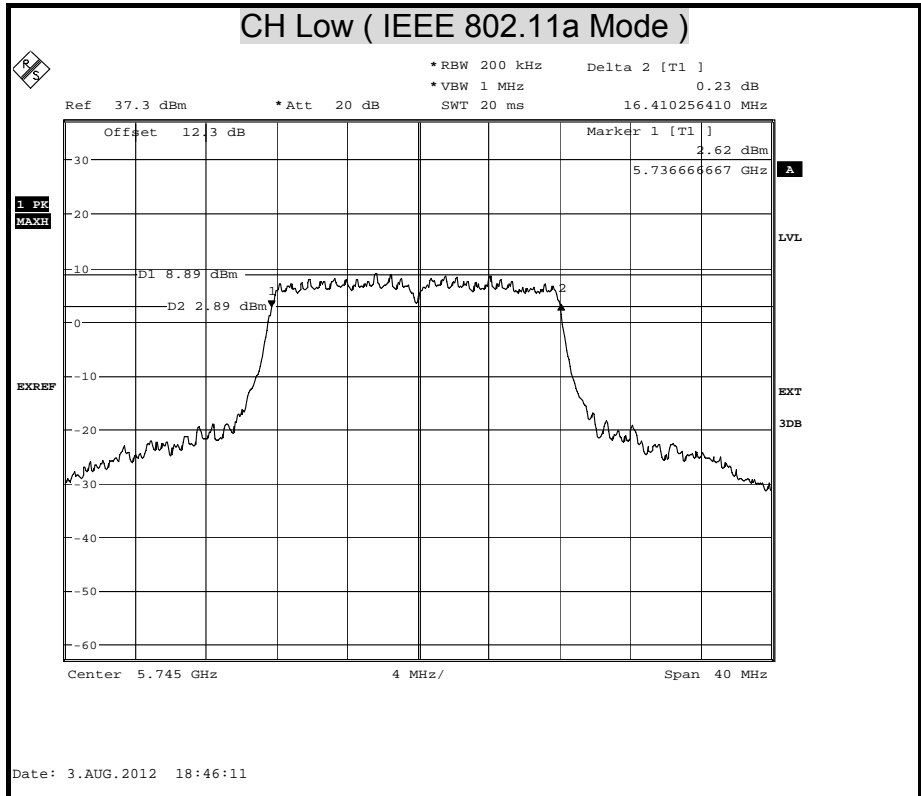

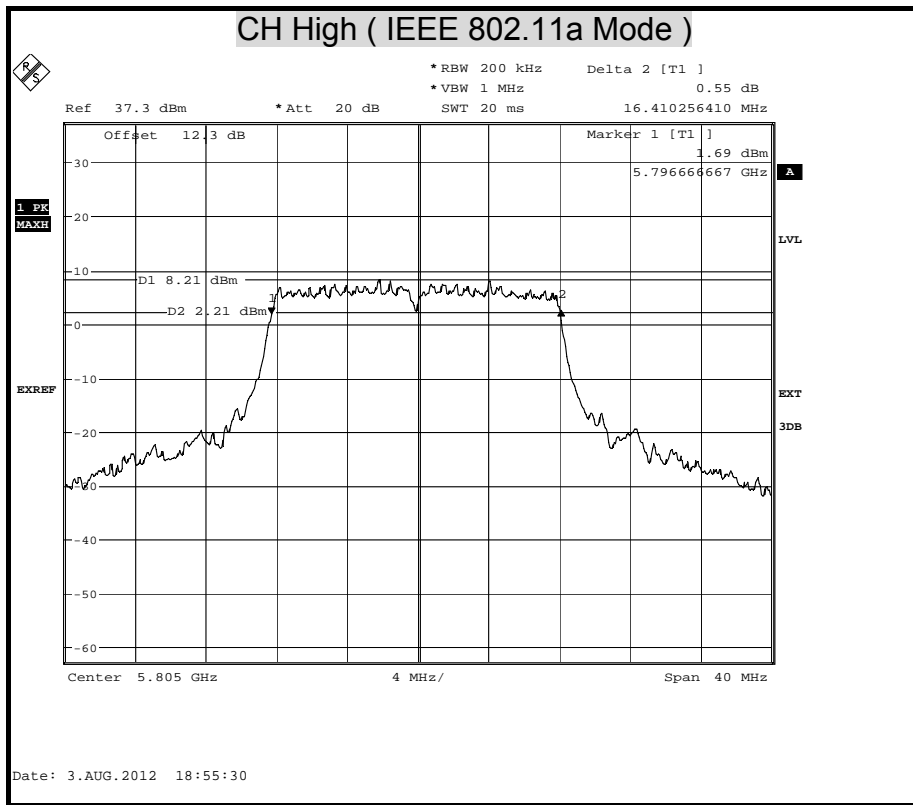

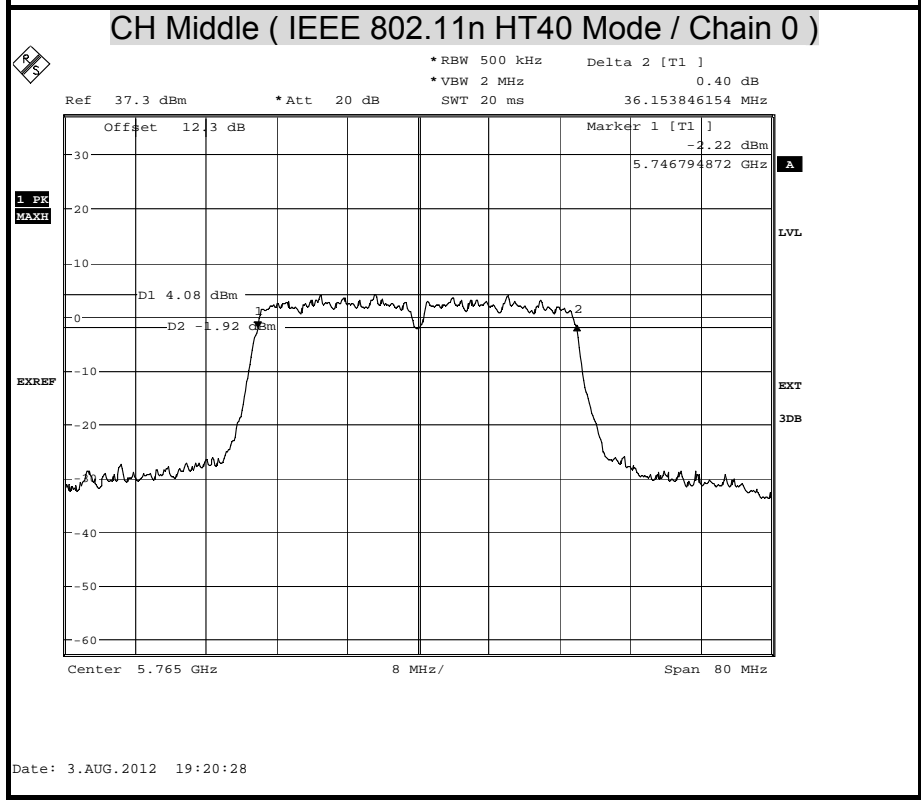
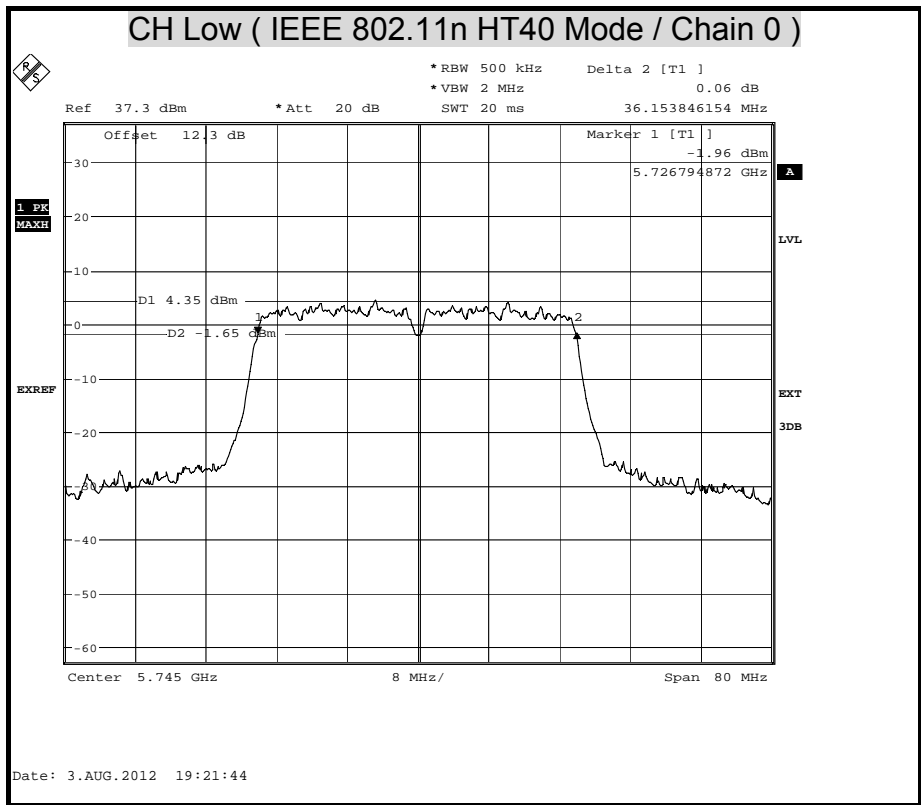

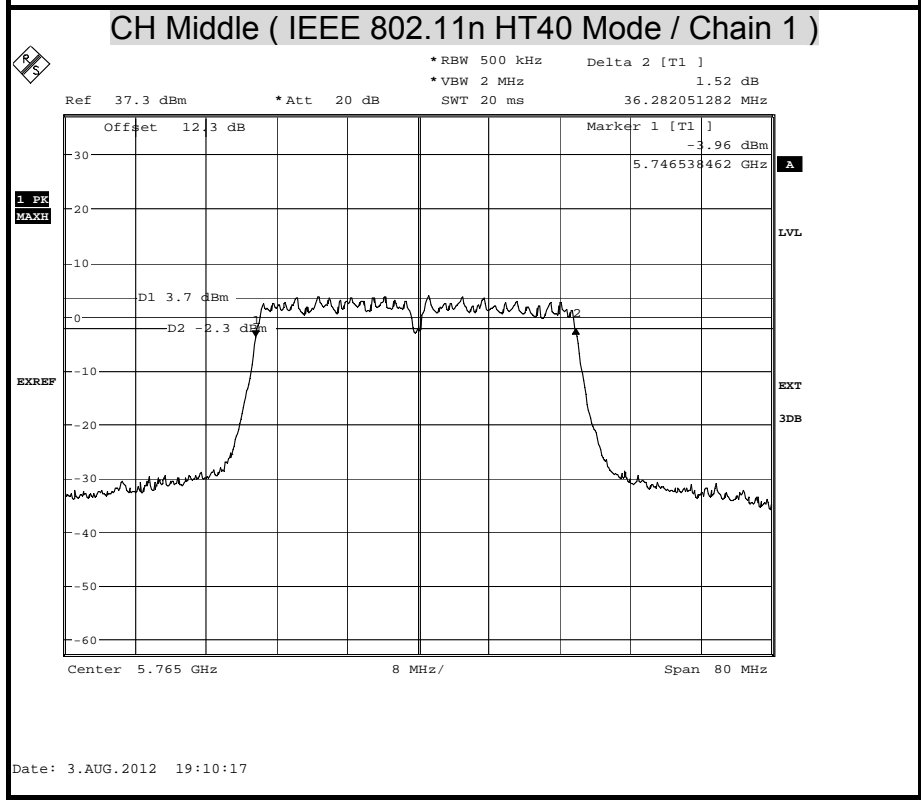
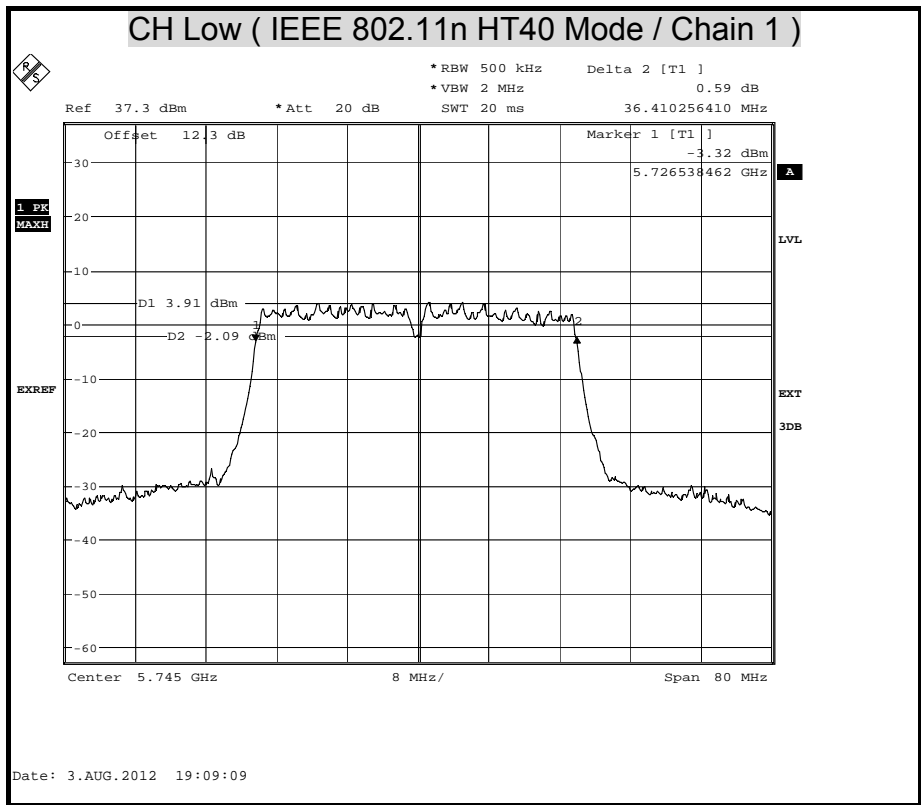



7.2 MAXIMUM PEAK OUTPUT POWER

LIMITS

§ 15.247(b) The maximum peak output power of the intentional radiator shall not exceed the following :

§ 15.247(b) (3) For systems using digital modulation in the 902-928 MHz, 2400-2483.5 MHz, and 5725-5850 MHz bands : 1 watt.

§ 15.247(b) (4) Except as shown in paragraphs (c) of this section, if transmitting antennas of directional gain greater than 6 dBi are used the peak output power from the intentional radiator shall be reduced below the stated values in paragraphs (b)(1) or (b)(2), and (b)(3) of this section, as appropriate, by the amount in dB that the directional gain of the antenna exceeds 6 dBi.

TEST EQUIPMENT

Name of Equipment	Manufacturer	Model	Serial Number	Calibration Due
Spectrum Analyzer	FSU	200789	---	SEP. 29, 2012

Remark: Each piece of equipment is scheduled for calibration once a year.

TEST SETUP

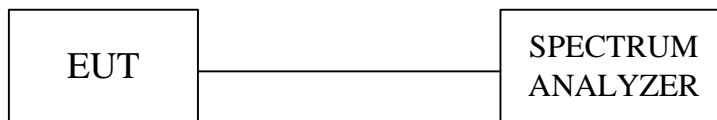



TEST PROCEDURE

The tests were performed in accordance with KDB 558074 5.2.1.2 and 5.2.2.1.

5.2.1.2 Measurement Procedure PK2:

- 1.This procedure provides an integrated measurement alternative when the maximum available RBW < EBW.
- 2.Set the RBW = 1 MHz.
- 3.Set the VBW = 3 MHz.
- 4.Set the span to a value that is 5-30 % greater than the EBW.
- 5.Detector = peak.
- 6.Sweep time = auto couple.
- 7.Trace mode = max hold.
- 8.Allow trace to fully stabilize.
- 9.Use the spectrum analyzer's integrated band power measurement function with band limits set equal to the EBW band edges(for some analyzers, this may require a manual override to ensure use of peak detector). If the spectrum analyzer does not have a band power function, sum the spectrum levels (in linear power units) at 1 MHz intervals extending across the EBW of the spectrum.

5.2.2.1 Measurement Procedure AVG1(power averaging over the EBW with slow sweep speed):

- 1.Set the analyzer span to 5-30% greater than the EBW.
- 2.Set the RBW = 1 MHz.
- 3.Set the VBW \geq 3 MHz.
- 4.Detector = power average (RMS).
- 5.Ensure that the number of measurement points in the sweep \geq 2 x (span/RBW).
- 6.Manually set the sweep time to: \geq 10 x (number of measurement points in sweep) x (transmission symbol period).
- 7.Perform the measurement over a single sweep.
- 8.Use the spectrum analyzer's integrated band power measurement function with band limits set equal to the EBW band edges to determine the maximum conducted output power of the EUT over the EBW. Note: If the analyzer does not have a band power function, sum the spectral levels (in linear power units) at 1 MHz intervals extending across the entire EBW.



TEST RESULTS

Antenna Gain1: 3 dBi
 Antenna Gain2: 3 dBi
 Array Gain=: $6.01 = 10 \cdot \log \left((10^{3/10}) + (10^{3/10}) \right)$
 Peak Power Limit: $29.99 = 30 - (6.01 - 6)$

IEEE 802.11b Mode

Channel	Channel Frequency (MHz)	Peak Power (dBm)	Peak Power Limit (dBm)	Pass / Fail
Low	2412	24.55	30	PASS
Middle	2437	25.21		PASS
High	2462	25.57		PASS

Remark: At final test to get the worst-case emission at 1Mbps.

IEEE 802.11g Mode

Channel	Channel Frequency (MHz)	Peak Power (dBm)	Peak Power Limit (dBm)	Pass / Fail
Low	2412	26.17	30	PASS
Middle	2437	26.97		PASS
High	2462	26.47		PASS

Remark: At final test to get the worst-case emission at 6Mbps.

IEEE 802.11n HT20 Mode

Channel	Channel Frequency (MHz)	Peak Power (dBm)		Peak Power Total (dBm)	Peak Power Limit (dBm)	Pass / Fail
		Chain 0	Chain 1			
Low	2412	22.46	19.02	24.08	29.99	PASS
Middle	2437	22.56	20.00	24.48		PASS
High	2462	23.40	21.72	25.65		PASS

Remark: At final test to get the worst-case emission at 13Mbps.



IEEE 802.11n HT40 Mode

Channel	Channel Frequency (MHz)	Peak Power (dBm)		Peak Power (dBm)	Peak Power Limit (dBm)	Pass / Fail
		Chain 0	Chain 0	(dBm)	(dBm)	
Low	2422	22.26	19.72	24.18	29.99	PASS
Middle	2437	22.25	19.38	24.06		PASS
High	2452	21.42	19.14	23.44		PASS

Remark: At final test to get the worst-case emission at 27Mbps.



Antenna Gain1: 5 dBi
 Antenna Gain2: 5 dBi
 Array Gain=: 8.01 = $10 \cdot \log \left((10^{5/10}) + (10^{5/10}) \right)$
 Peak Power Limit: 27.99 = $30 - (8.01 - 6)$

IEEE 802.11a Mode

Channel	Channel Frequency (MHz)	Peak Power (dBm)	Peak Power Limit (dBm)	Pass / Fail
Low	5745	25.35	30	PASS
Middle	5765	25.22		PASS
High	5805	24.86		PASS

Remark: At final test to get the worst-case emission at 6Mbps.

IEEE 802.11n HT20 Mode

Channel	Channel Frequency (MHz)	Peak Power (dBm)		Peak Power Total (dBm)	Peak Power Limit (dBm)	Pass / Fail
		Chain 0	Chain 1			
Low	5745	21.70	18.57	23.42	27.99	PASS
Middle	5765	21.54	18.04	23.14		PASS
High	5805	21.07	18.23	22.89		PASS

Remark: At final test to get the worst-case emission at 13Mbps.

IEEE 802.11n HT40 Mode

Channel	Channel Frequency (MHz)	Peak Power (dBm)		Peak Power Total (dBm)	Peak Power Limit (dBm)	Pass / Fail
		Chain 0	Chain 1			
Low	5745	21.38	19.32	23.48	27.99	PASS
Middle	5765	21.23	18.71	23.16		PASS
High	5805	20.94	18.11	22.76		PASS

Remark: At final test to get the worst-case emission at 27Mbps.



Average Power (2.4G)

802.11b Mode

Channel	Frequency (MHz)	Average Power (dBm)
Low	2412	21.68
Middle	2437	22.63
High	2462	22.73

802.11g Mode

Channel	Frequency (MHz)	Average Power (dBm)
Low	2412	20.44
Middle	2437	20.83
High	2462	20.80

802.11n HT20 Mode

Channel	Frequency (MHz)	Average Power Chain0 (dBm)	Average Power Chain1 (dBm)
Low	2412	16.16	13.65
Middle	2437	16.64	13.92
High	2462	17.25	16.54

802.11n HT40 Mode

Channel	Frequency (MHz)	Average Power Chain0 (dBm)	Average Power Chain1 (dBm)
Low	2422	16.48	13.61
Middle	2437	15.98	13.89
High	2452	15.43	12.97



Average Power (5G)

802.11a Mode

Channel	Frequency	Output Power	Output Power
	(MHz)	(dBm)	(W)
Low	5745	17.90	0.0617
Middle	5765	17.67	0.0585
High	5805	17.38	0.0547

802.11n HT20 Mode

Channel	Frequency	Chain 0	Chain 1	Total Output Power (dBm)	Output Power (W)
	(MHz)	Output Power (dBm)	Output Power (dBm)		
Low	5745	14.01	10.56	15.63	0.0366
Middle	5765	13.71	10.11	15.28	0.0338
High	5805	13.13	10.38	14.98	0.0315

802.11n HT40 Mode

Channel	Frequency	Chain 0	Chain 1	Total Output Power (dBm)	Output Power (W)
	(MHz)	Output Power (dBm)	Output Power (dBm)		
Low	5745	13.44	11.33	15.52	0.0357
Middle	5765	13.21	10.84	15.20	0.0331
High	5805	13.09	10.13	14.87	0.0307



MAXIMUM PEAK OUTPUT POWER (2.4G)

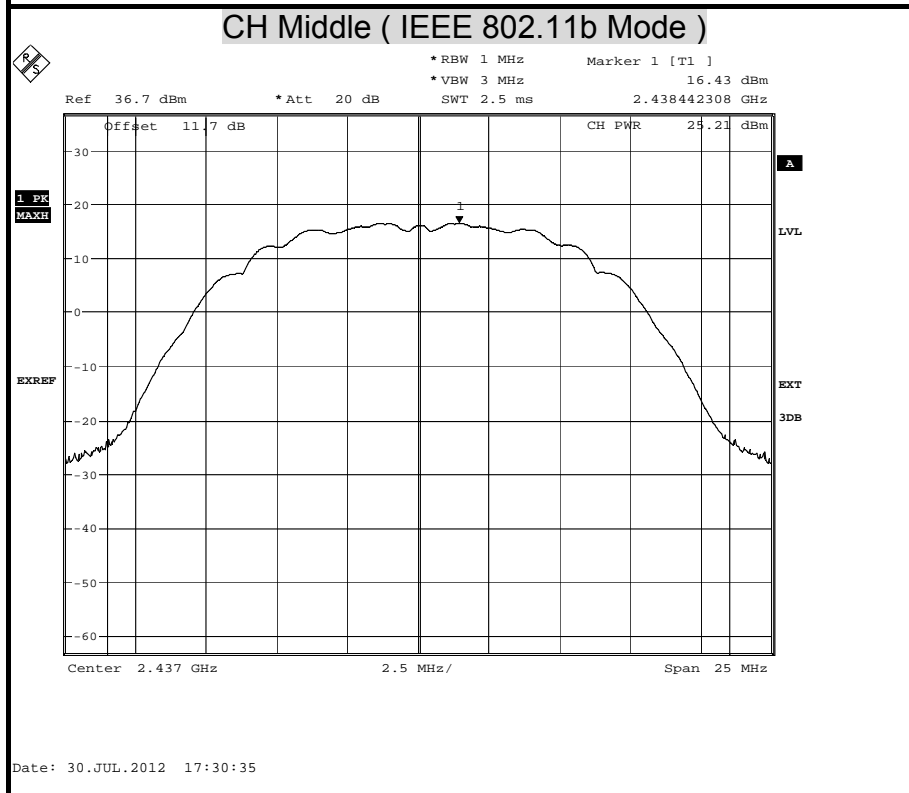
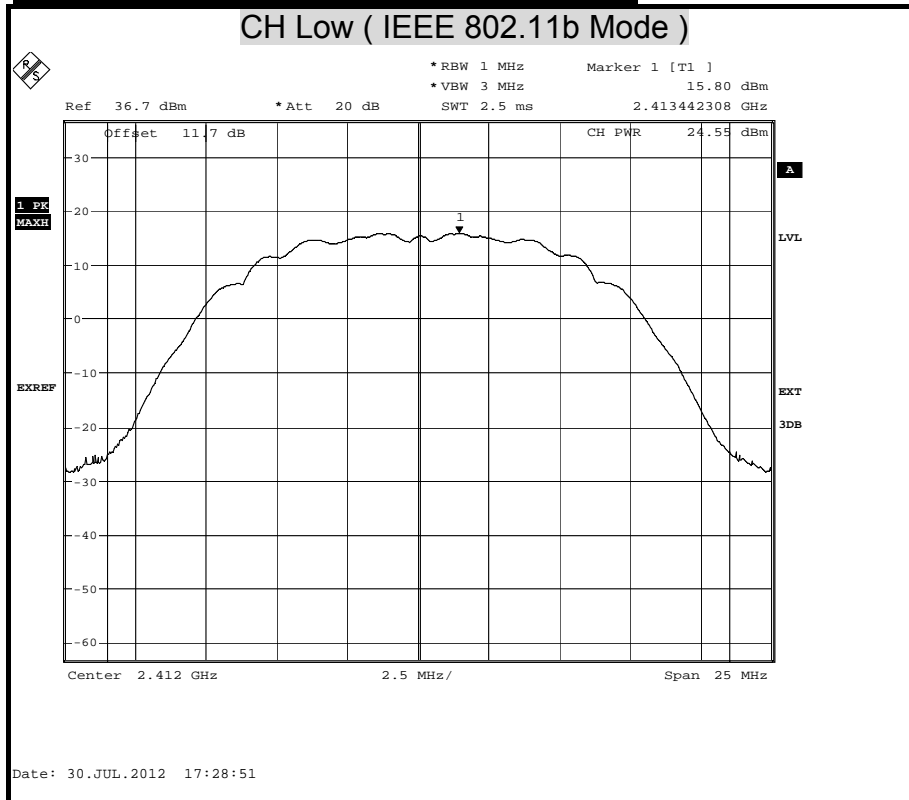

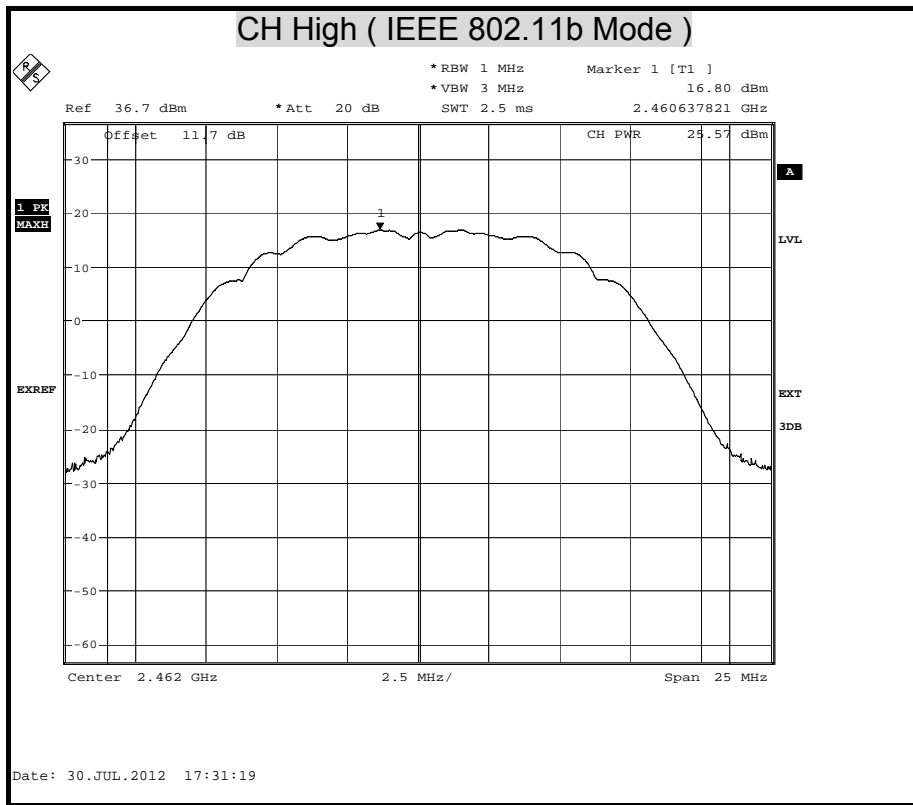

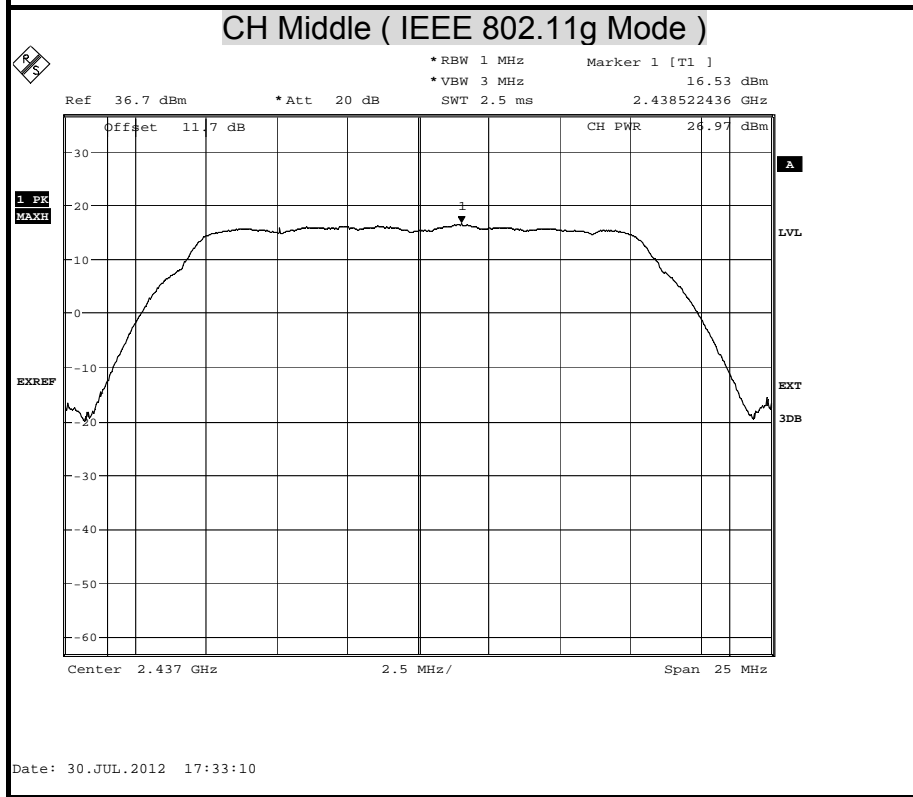
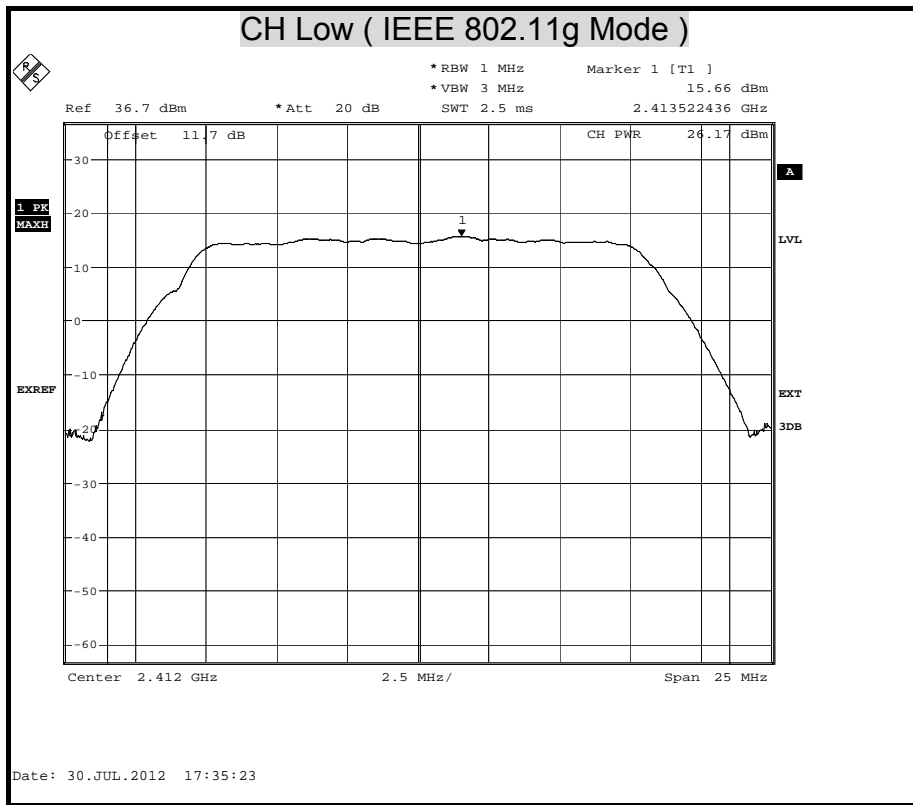

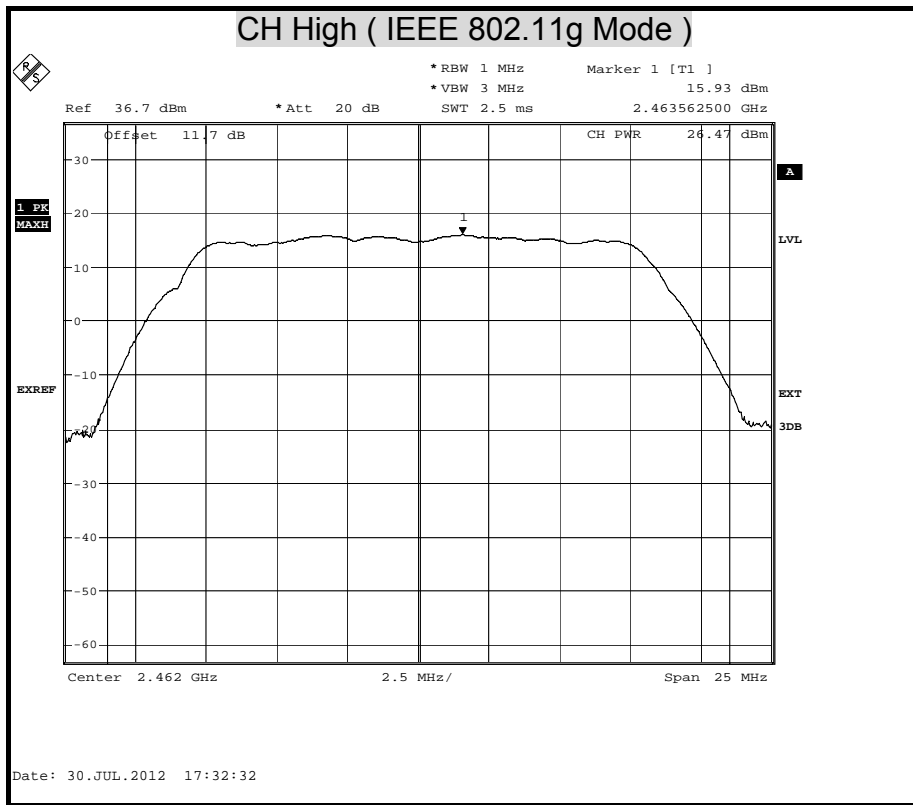

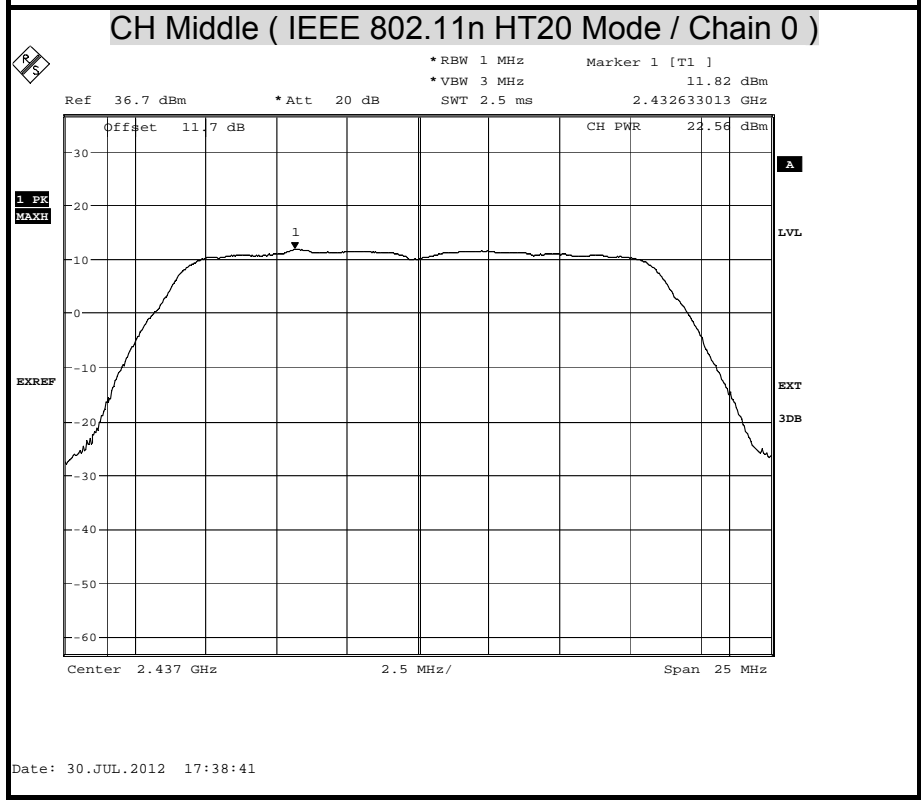
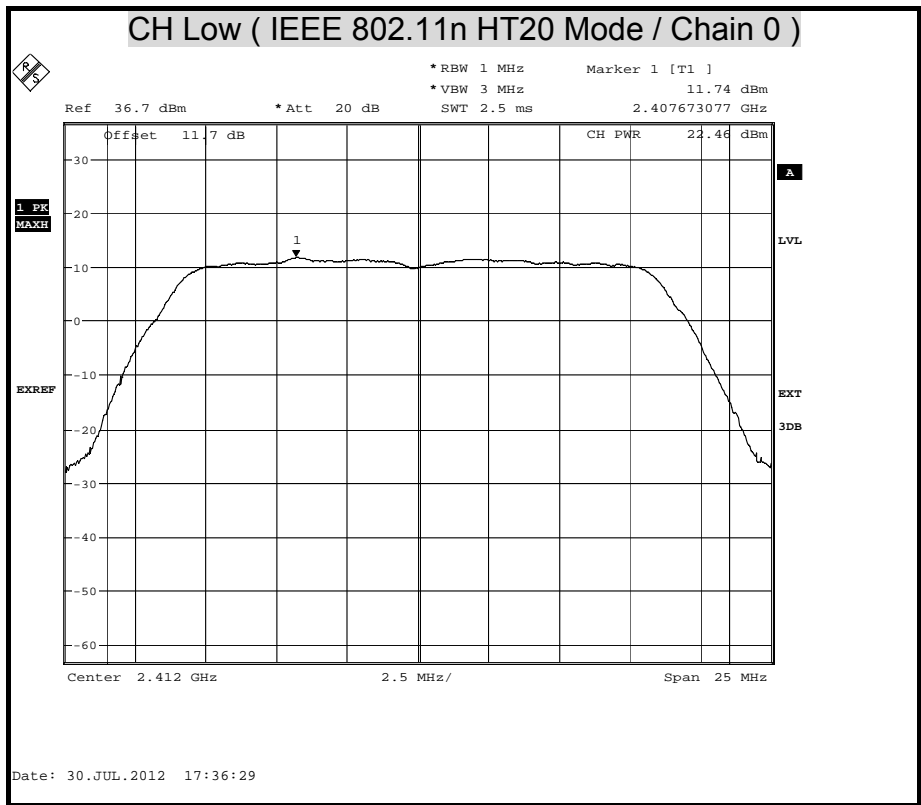

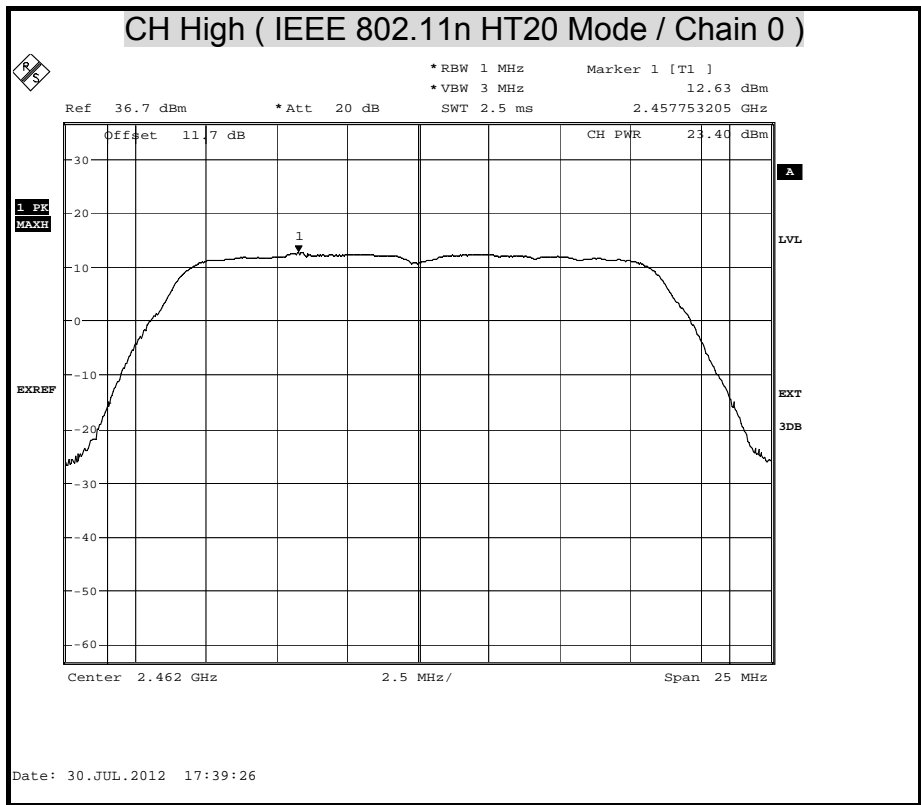

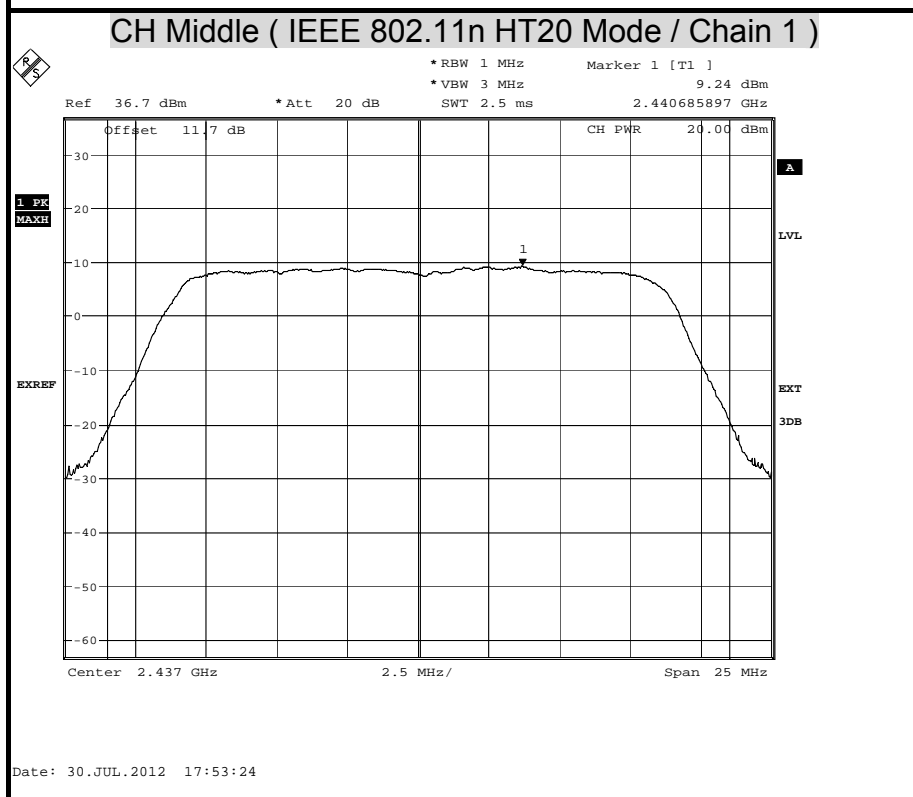
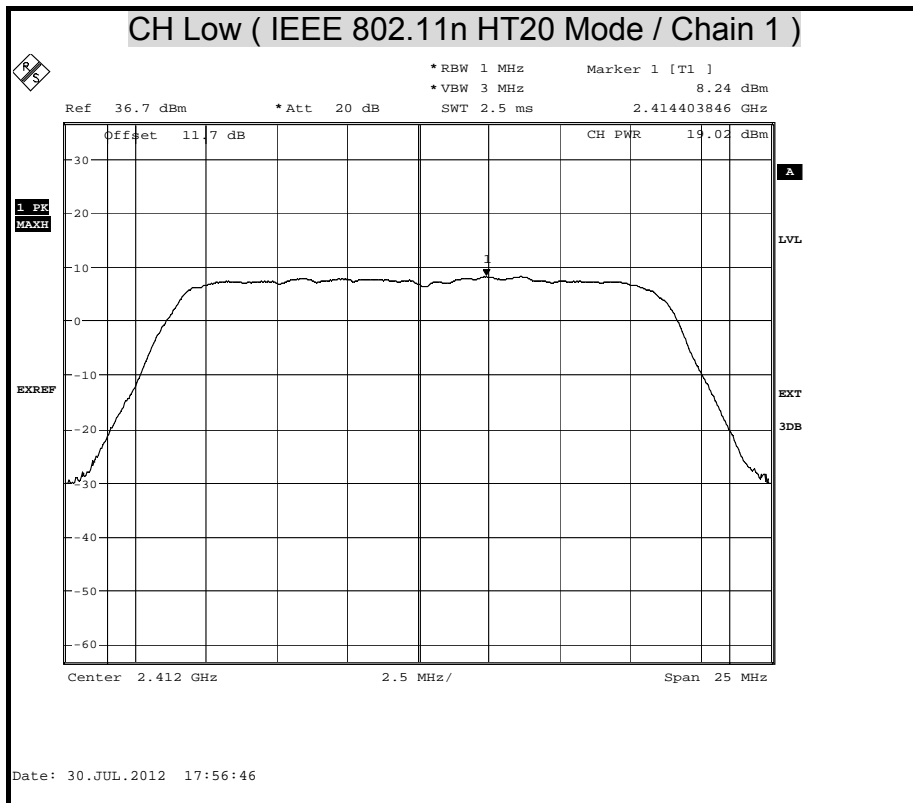

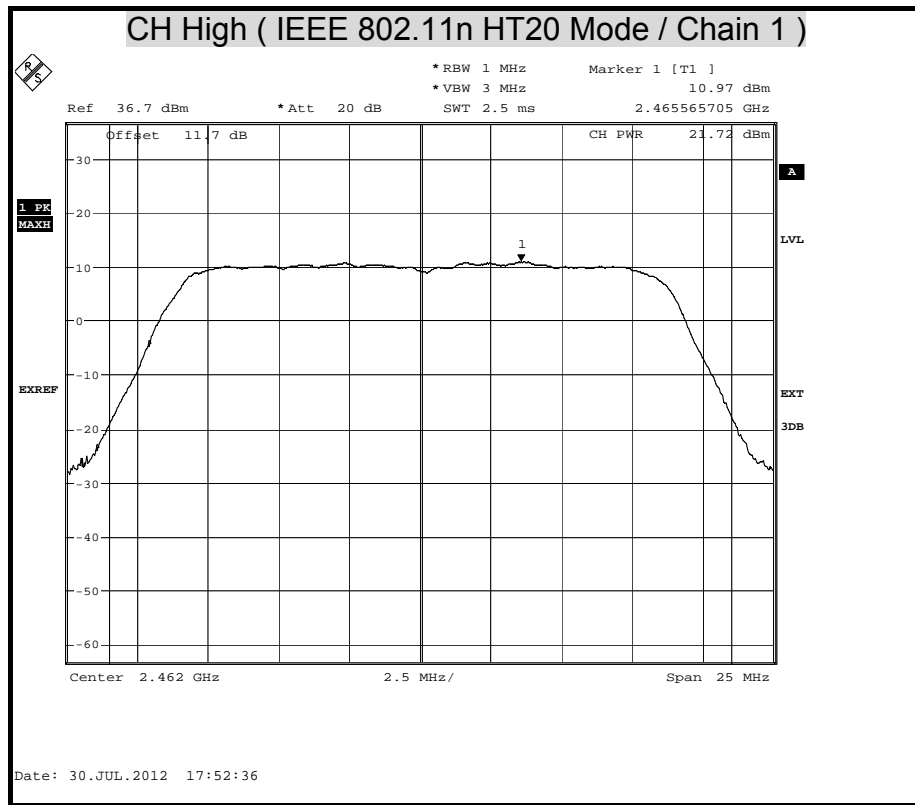

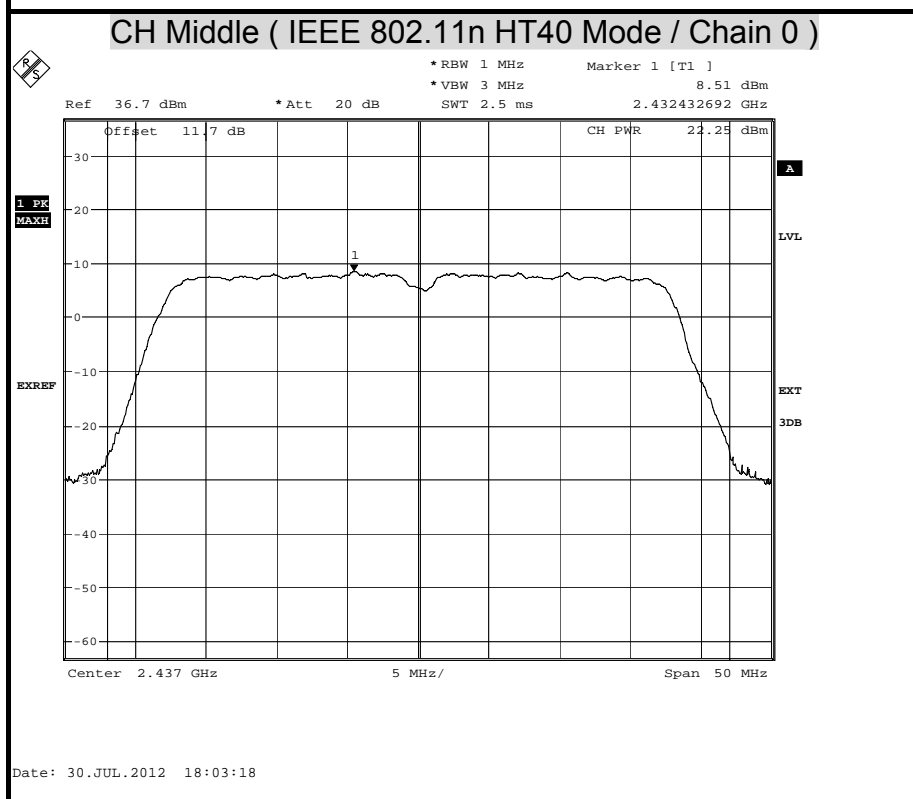
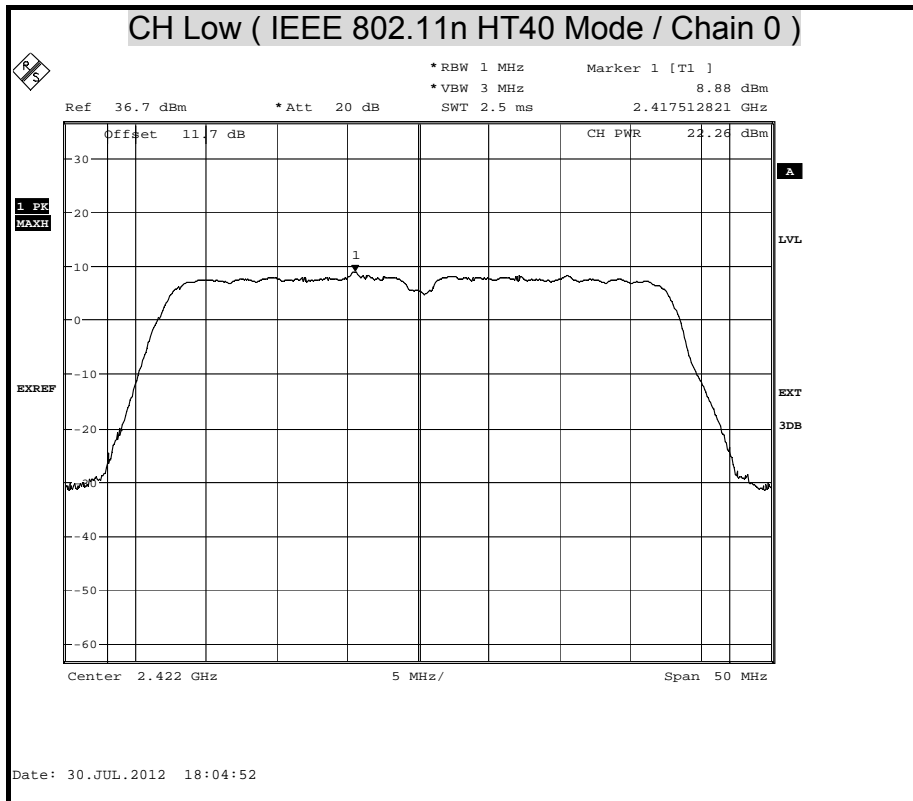

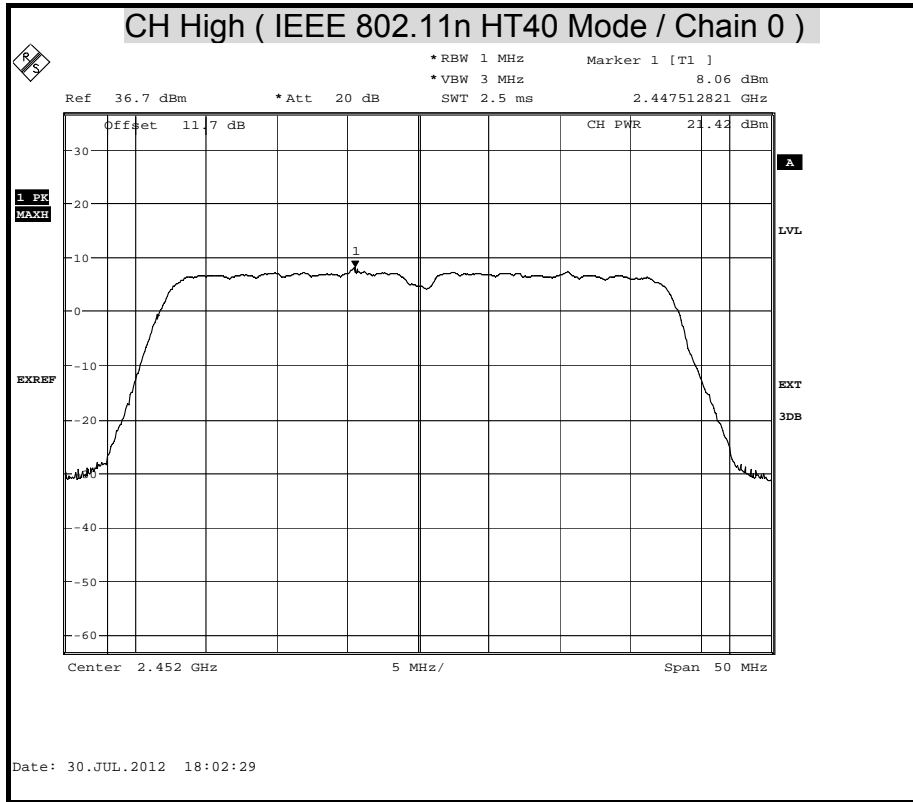

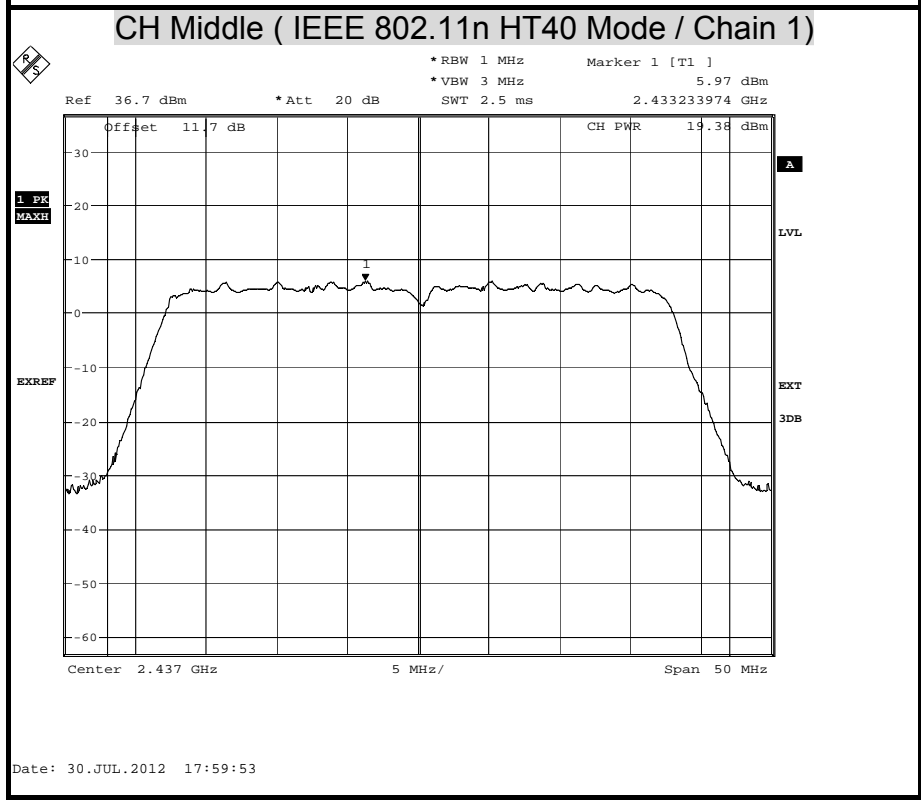
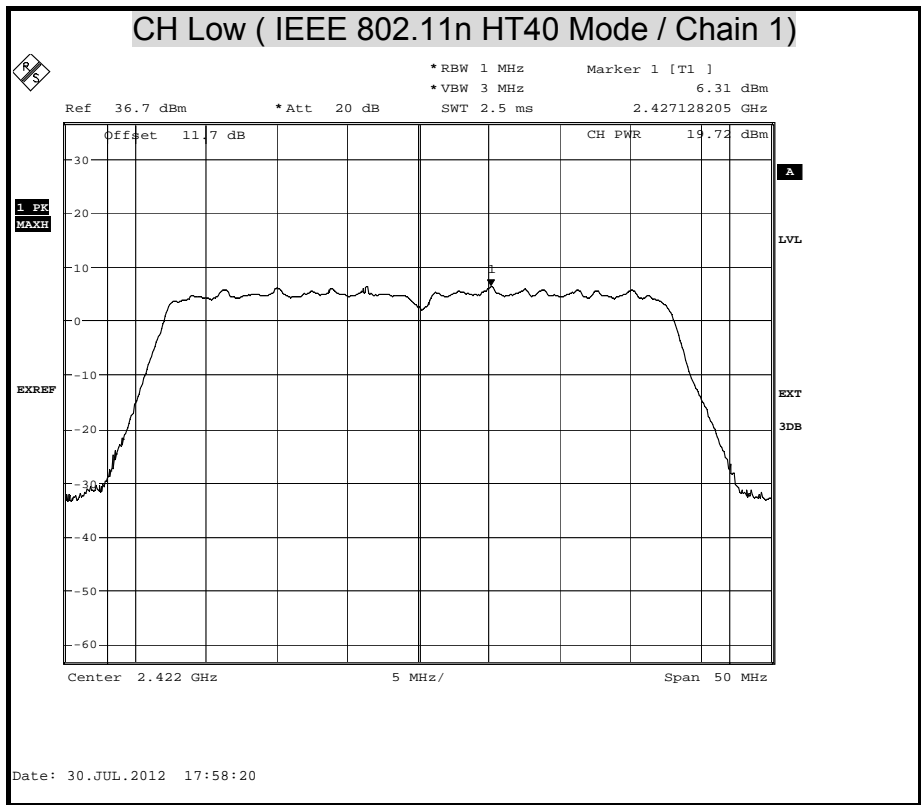

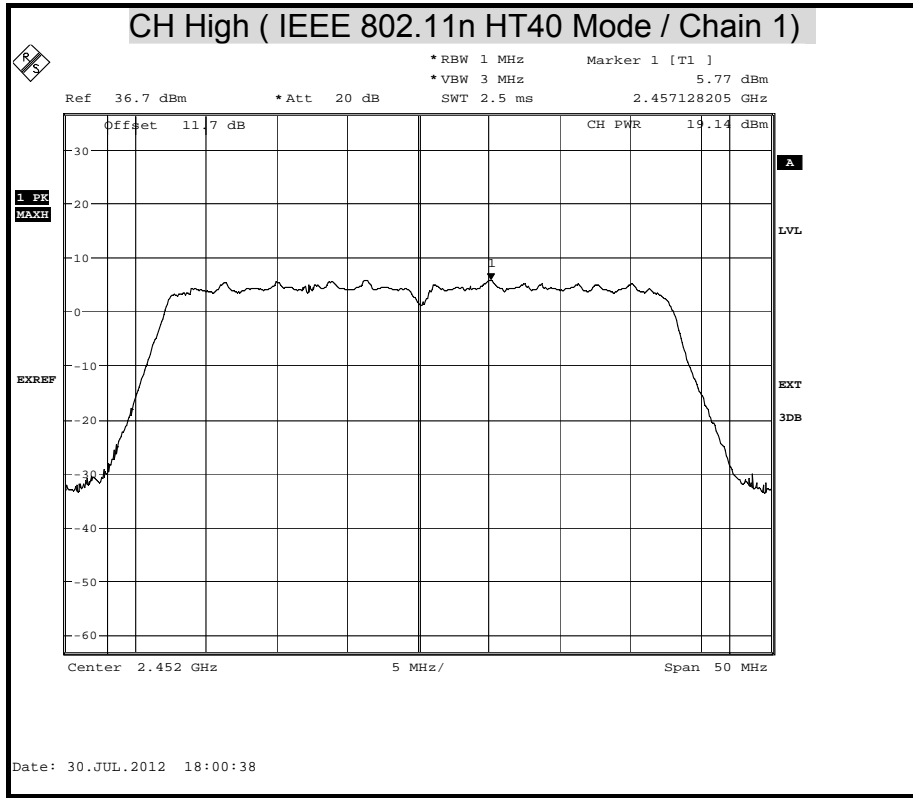



MAXIMUM PEAK OUTPUT POWER (5G)

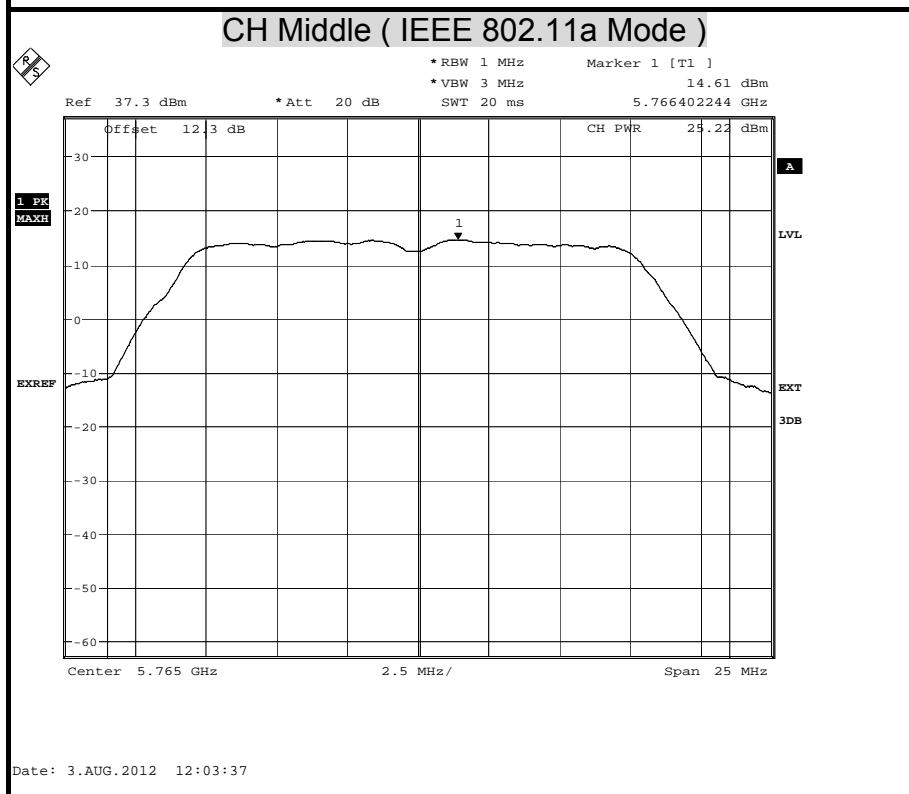
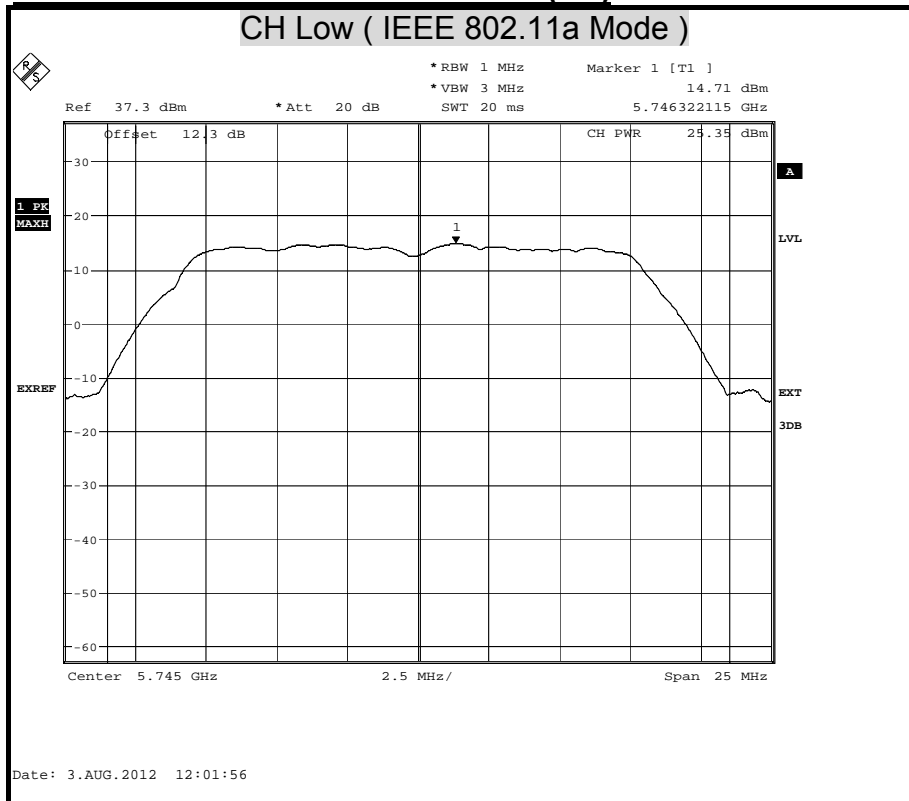

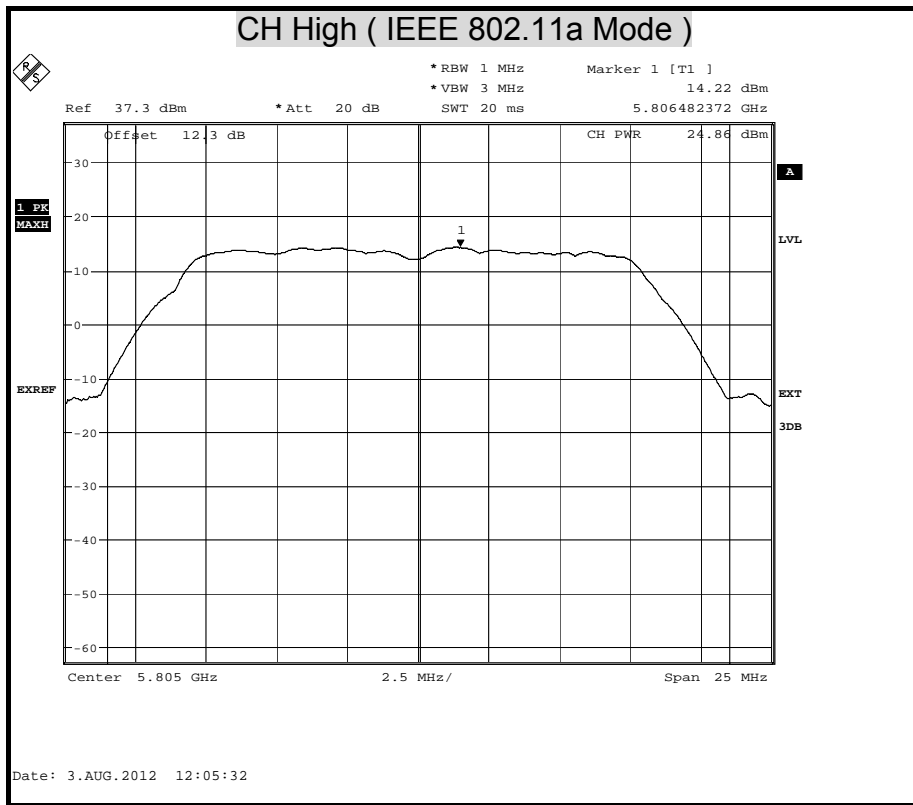

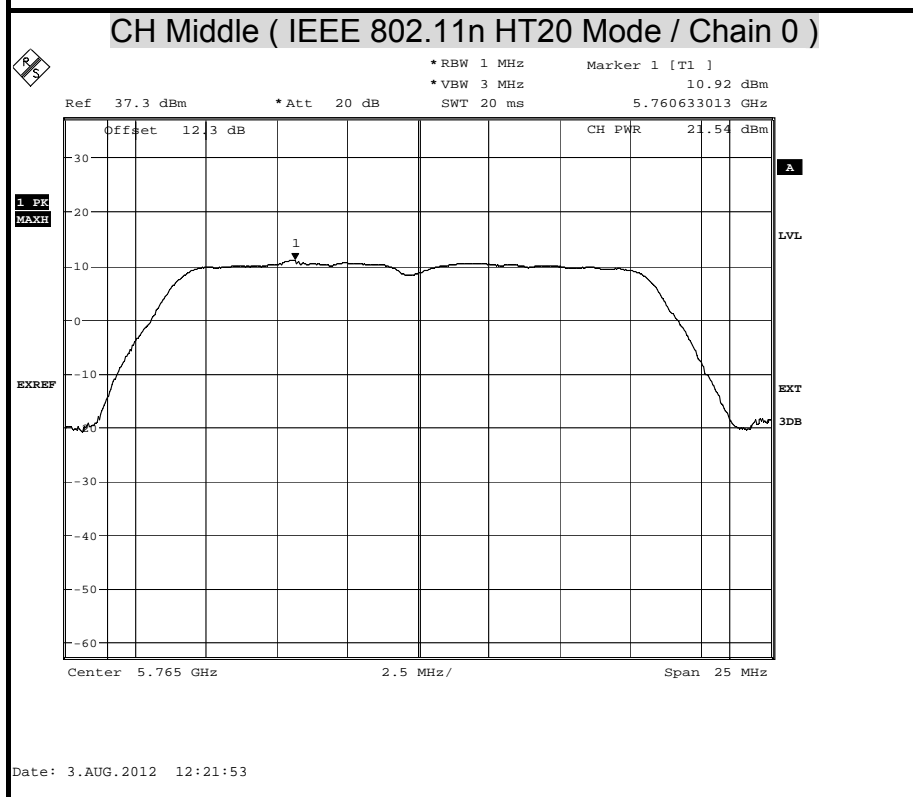
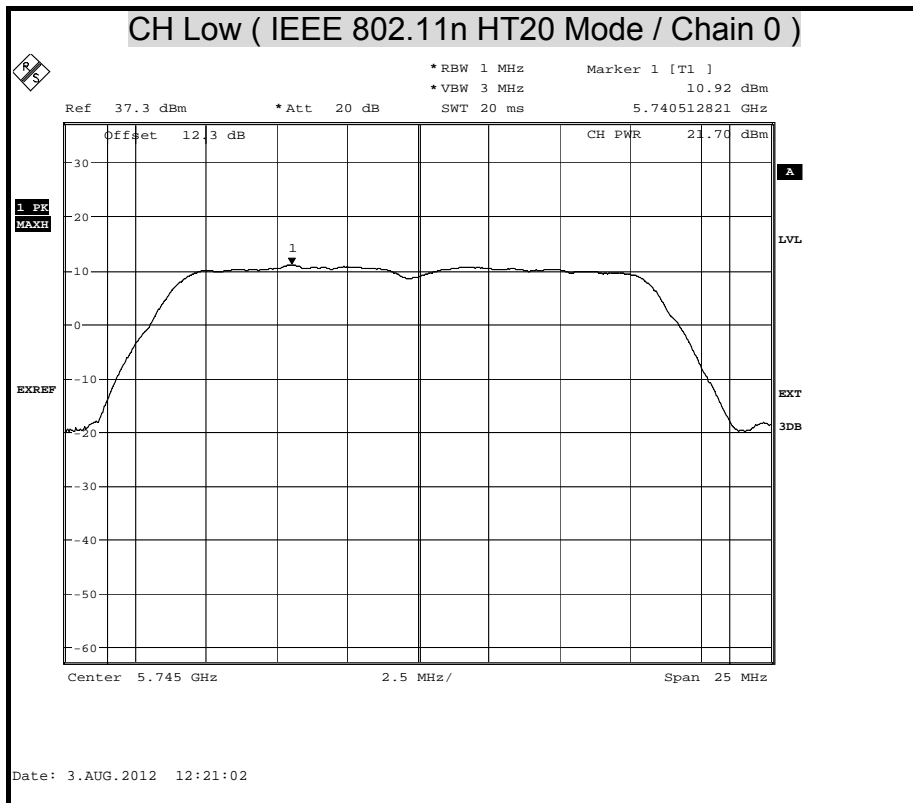

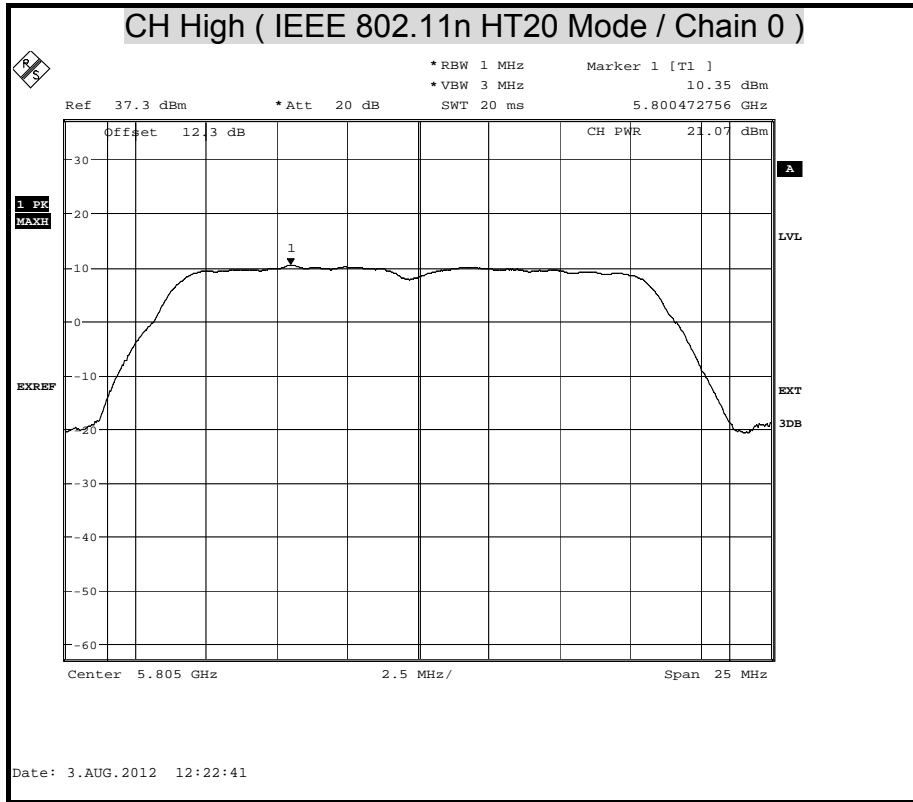

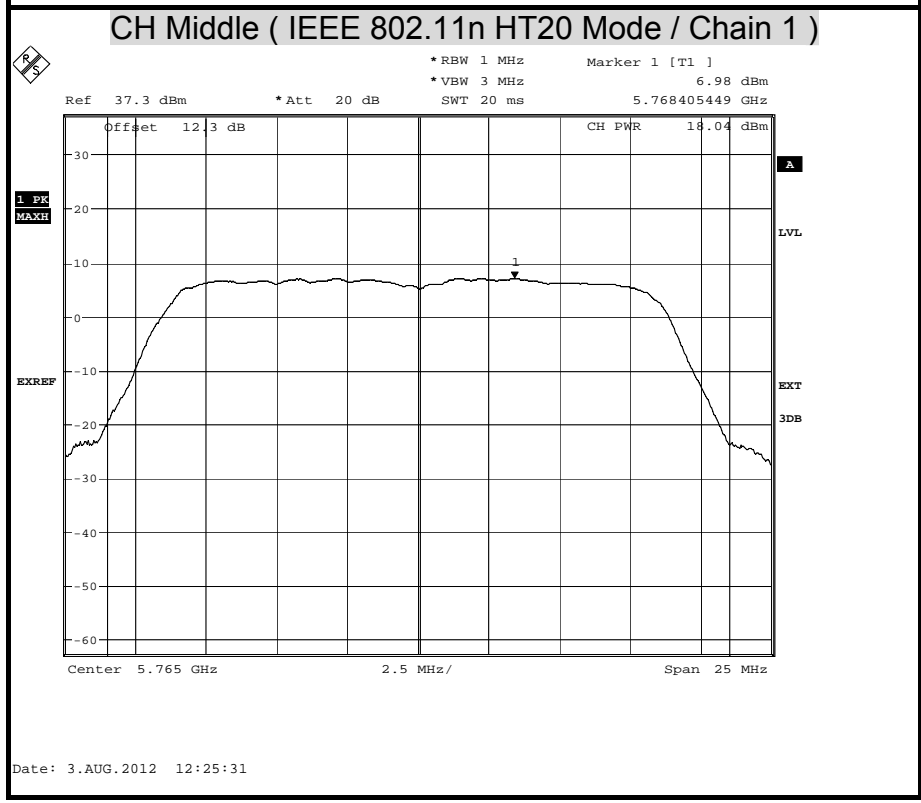
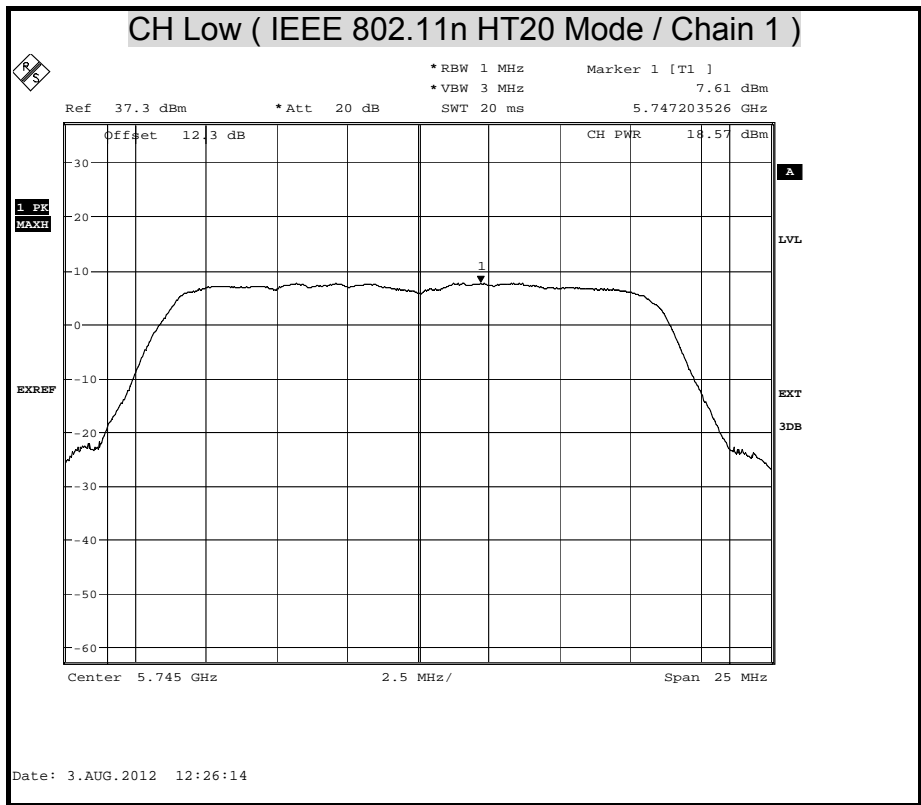

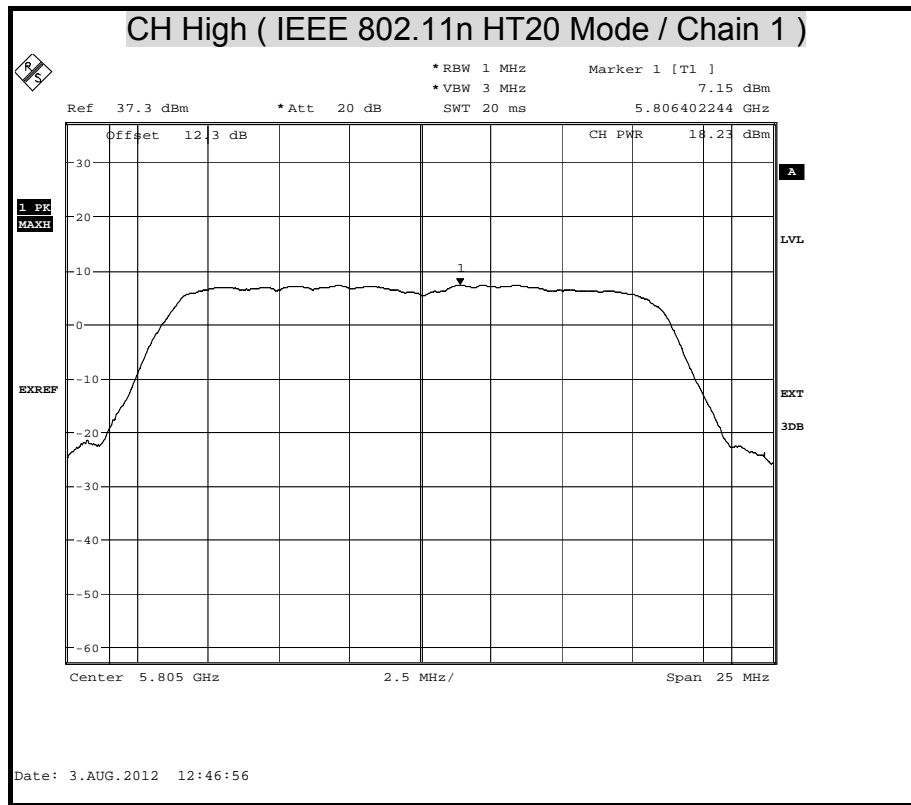

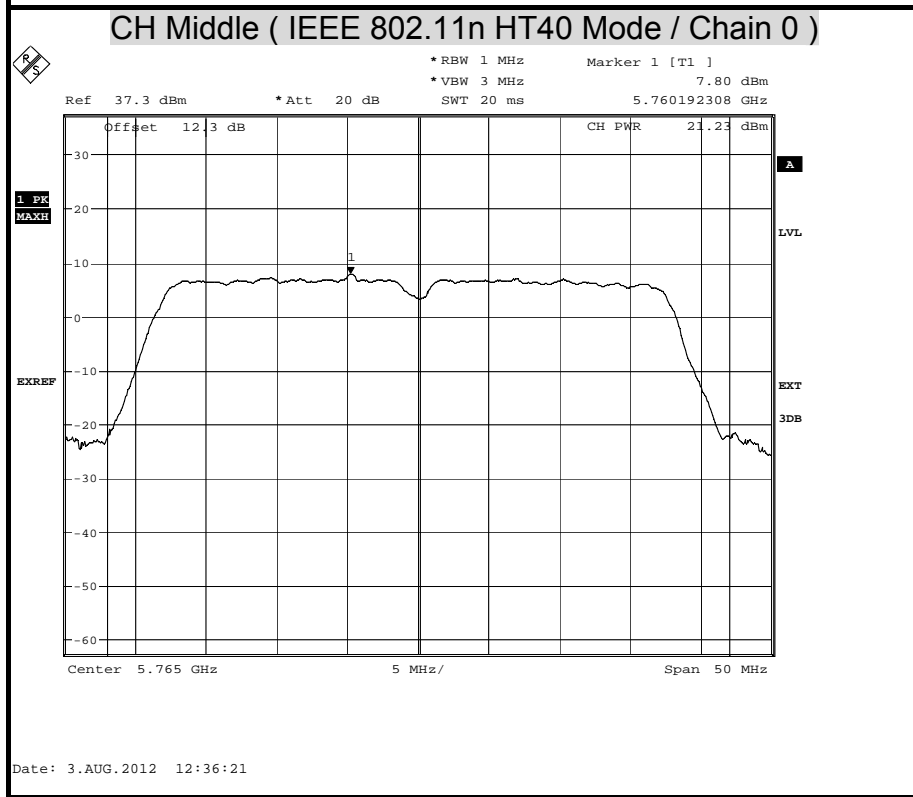
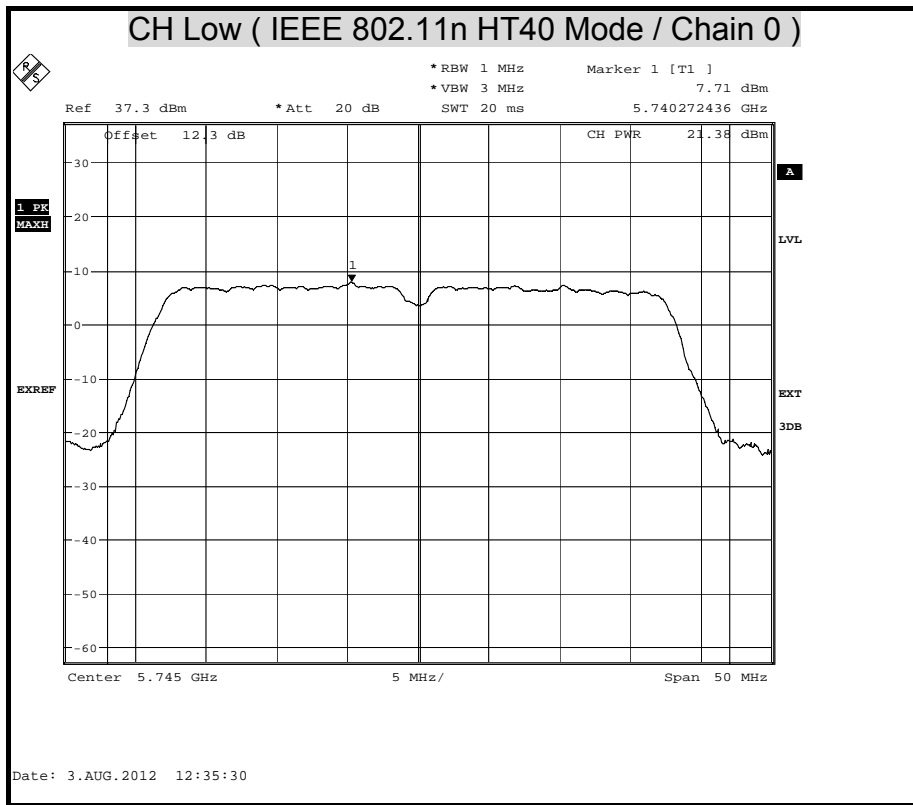

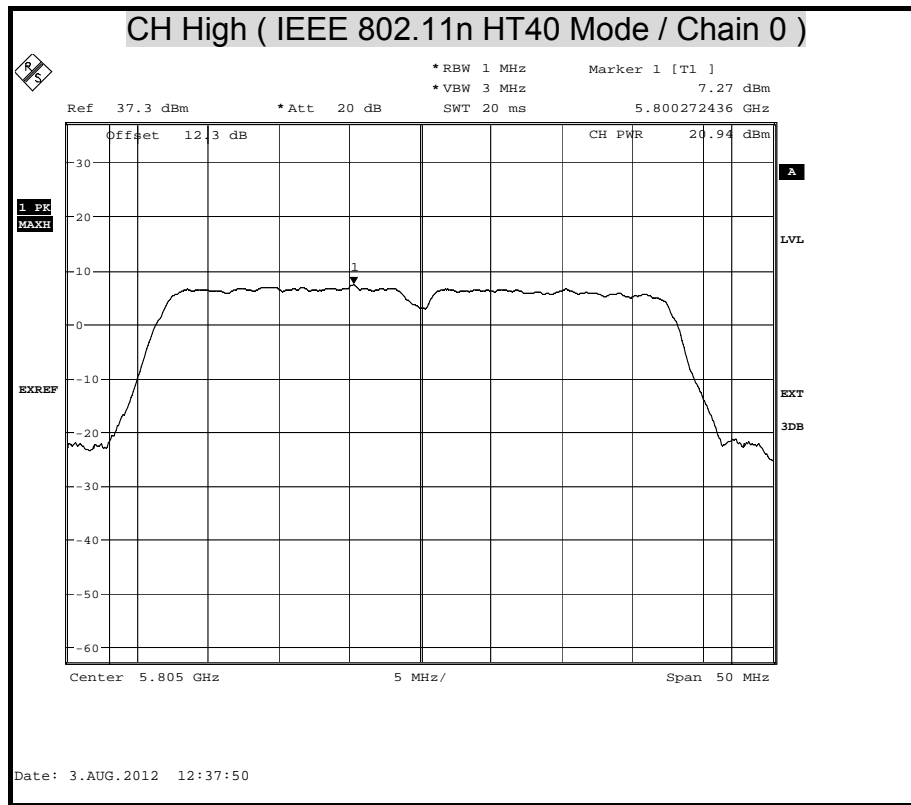

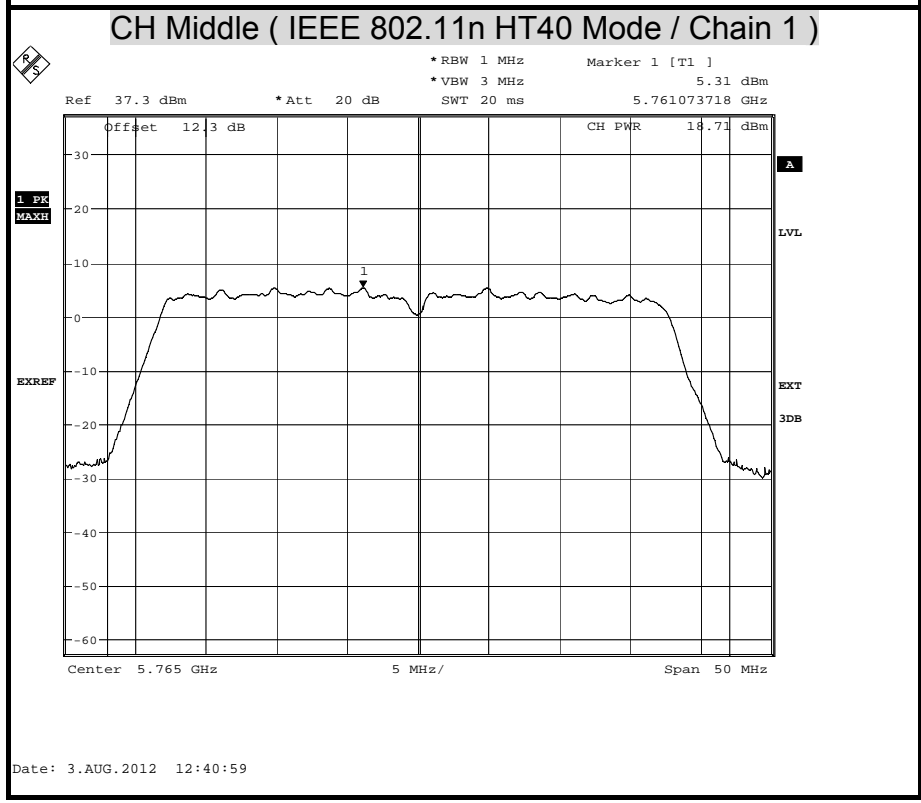
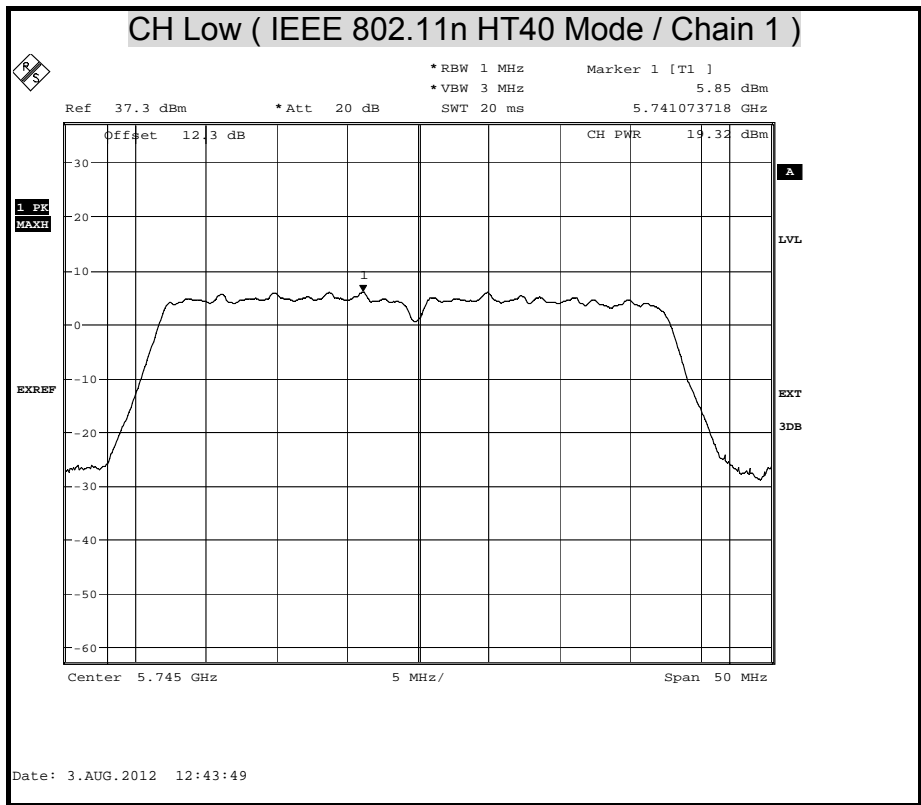

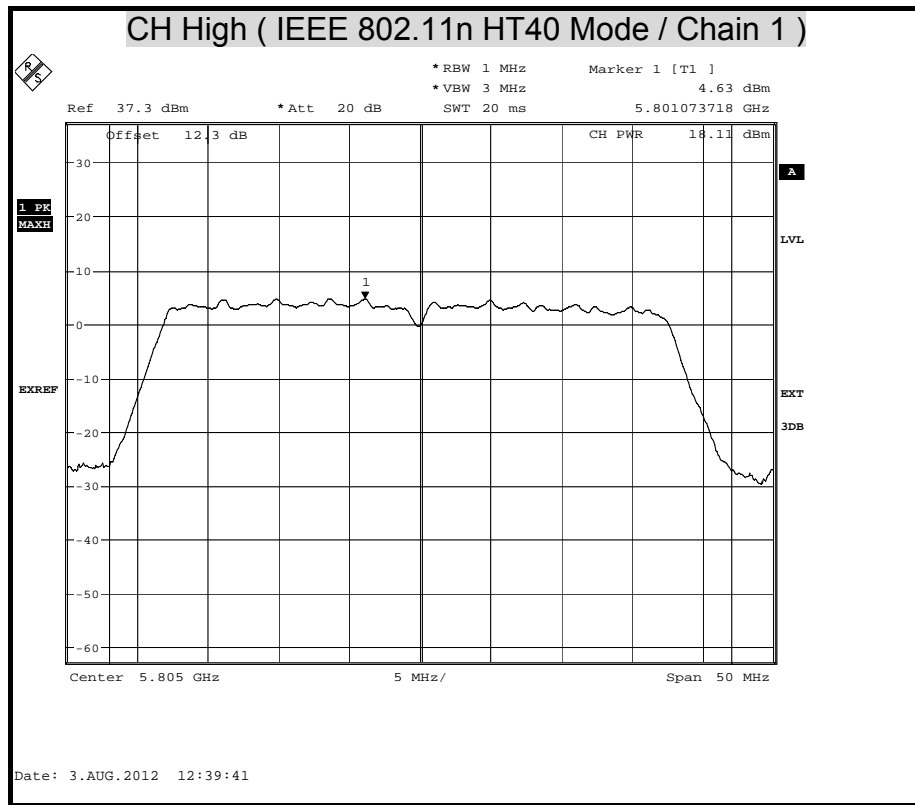



AVERAGE POWER(2.4G)

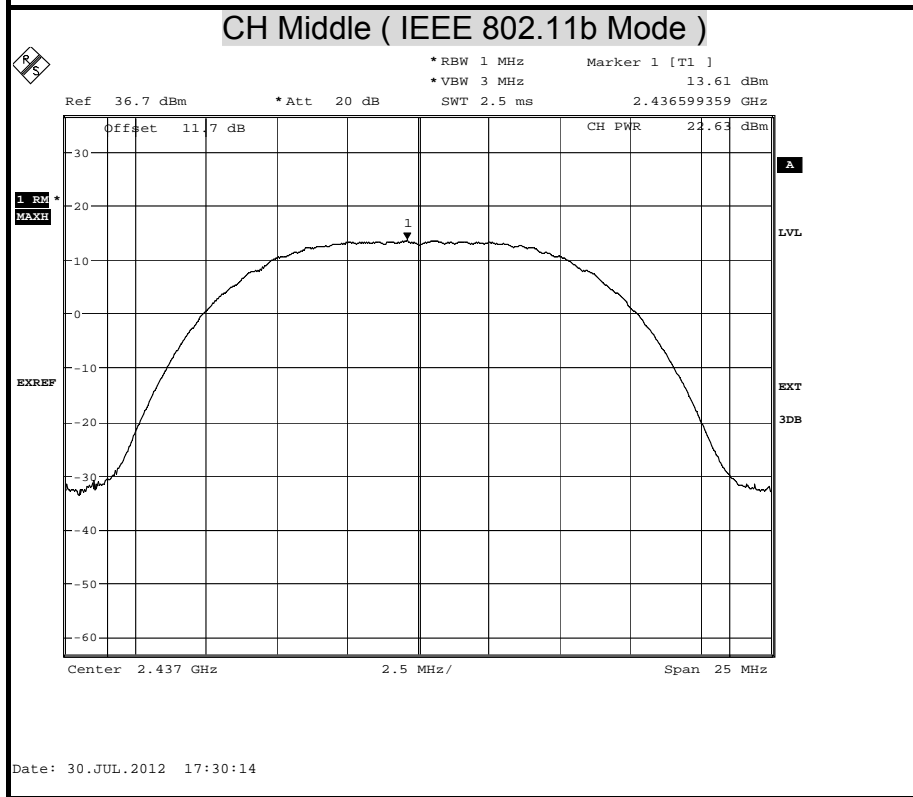
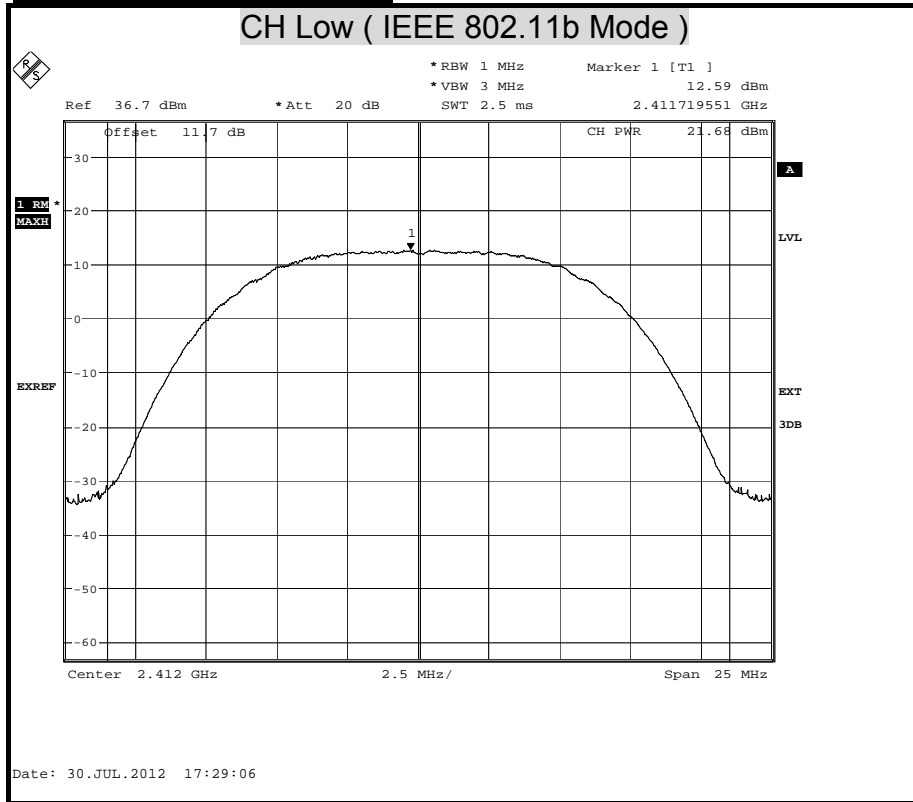

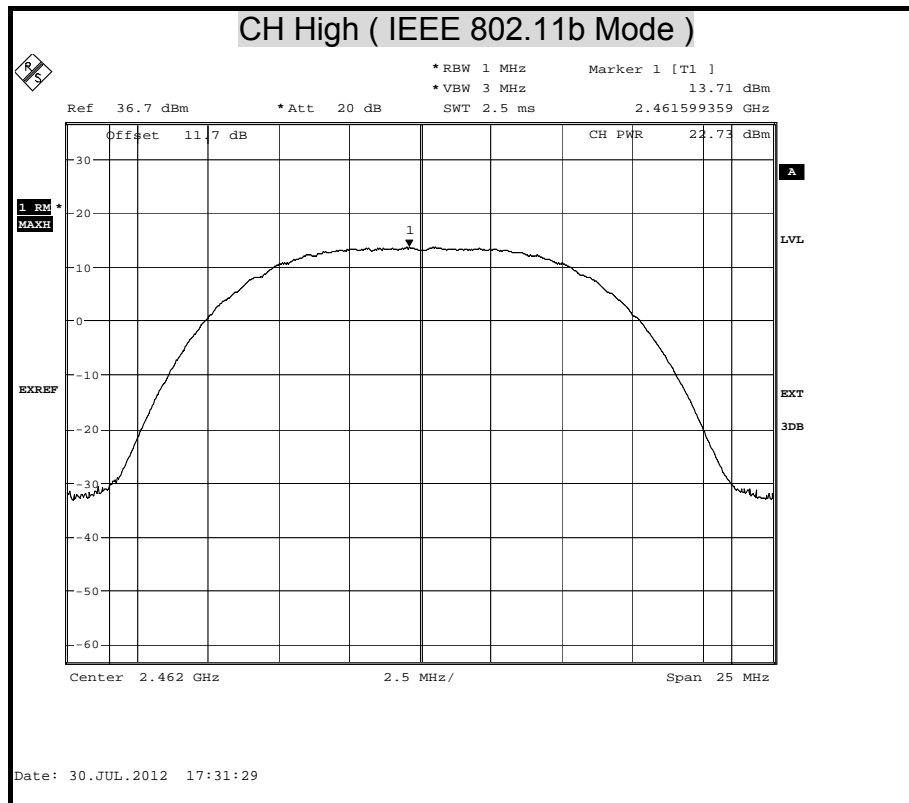

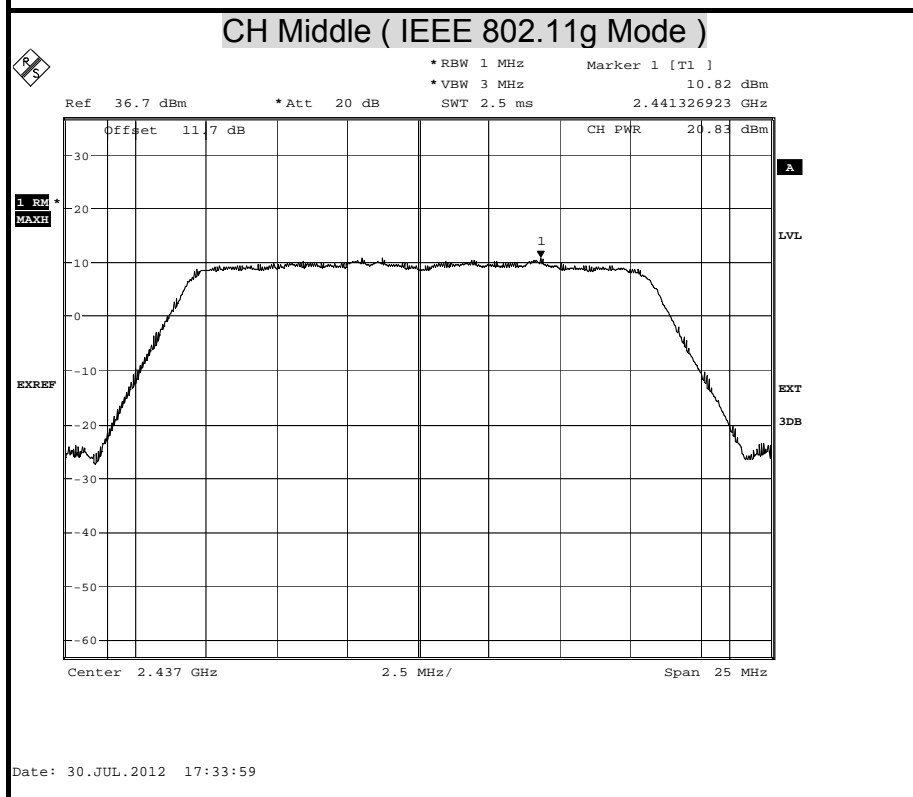
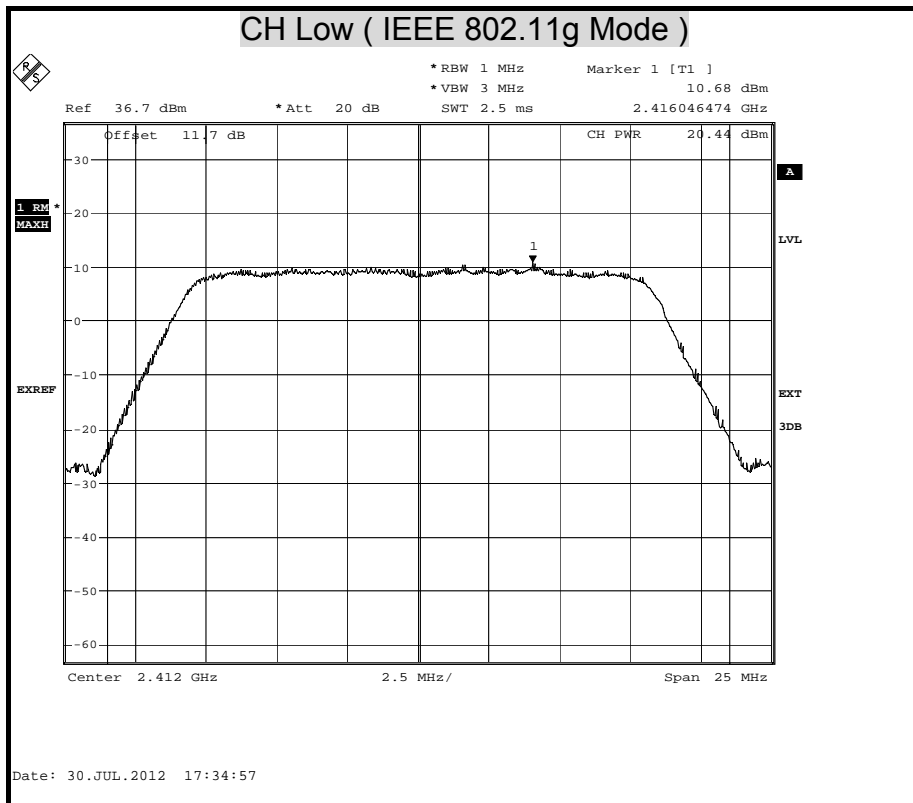

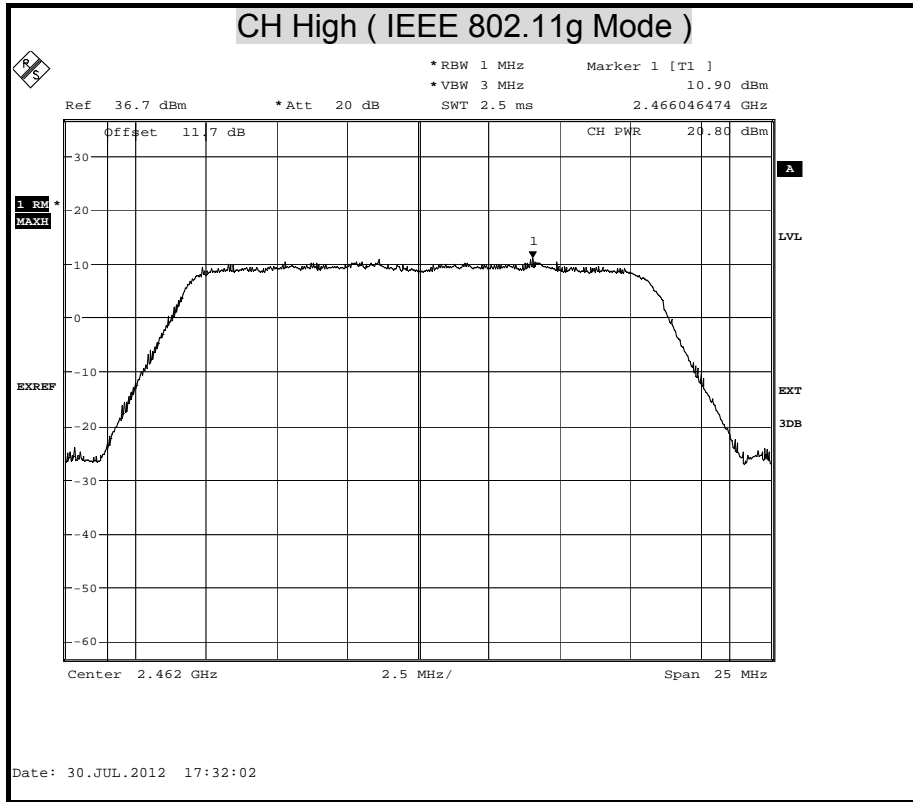

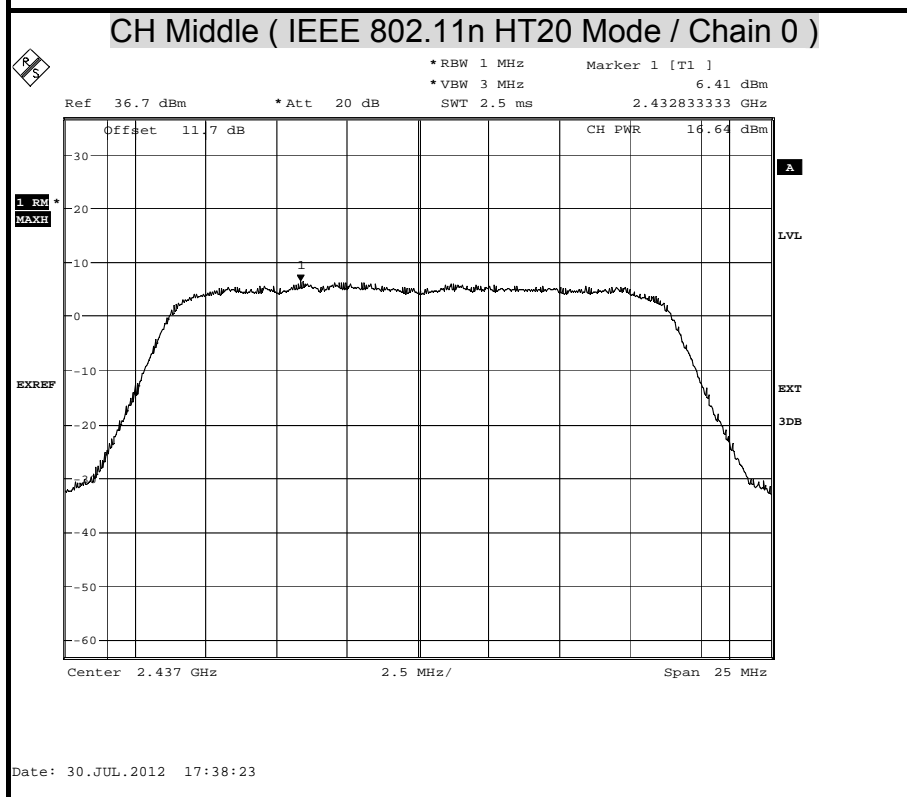
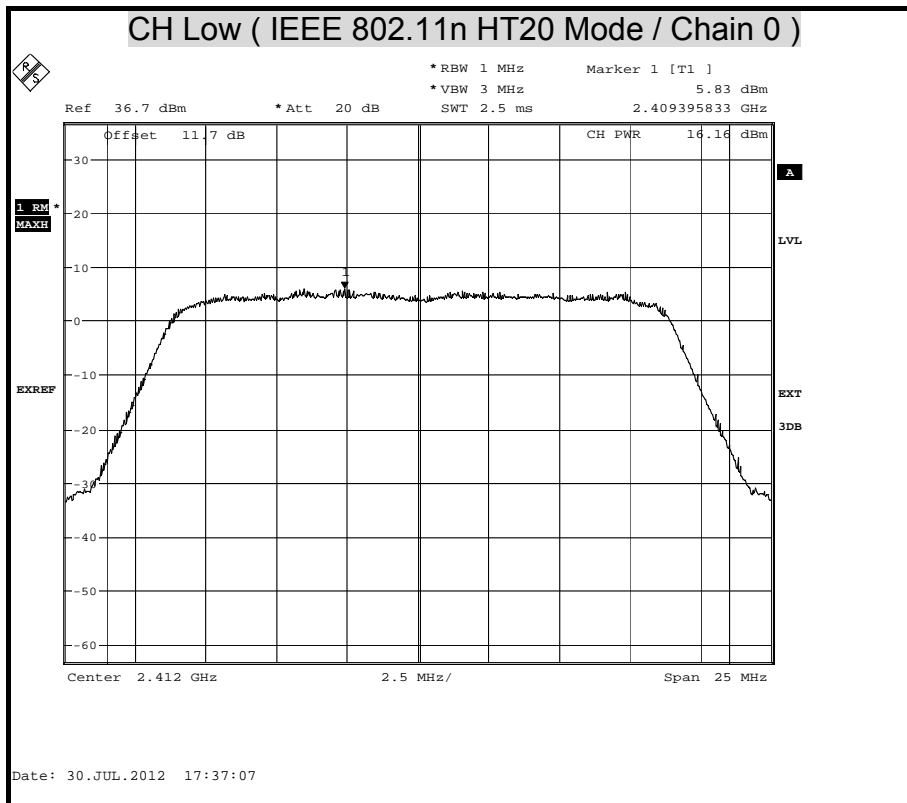

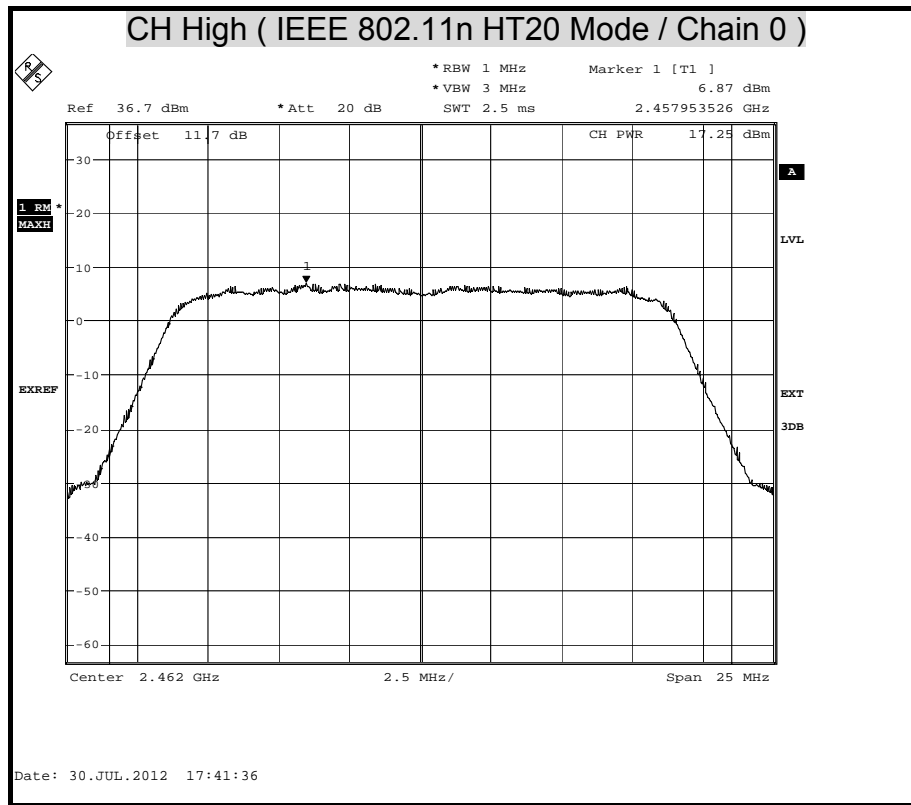

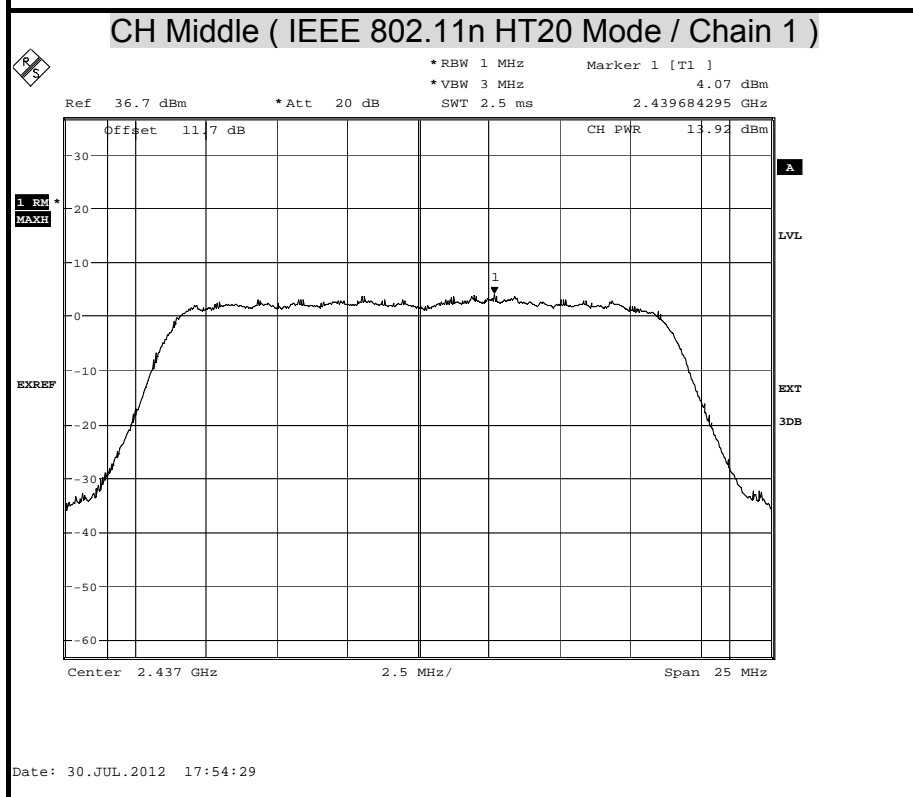
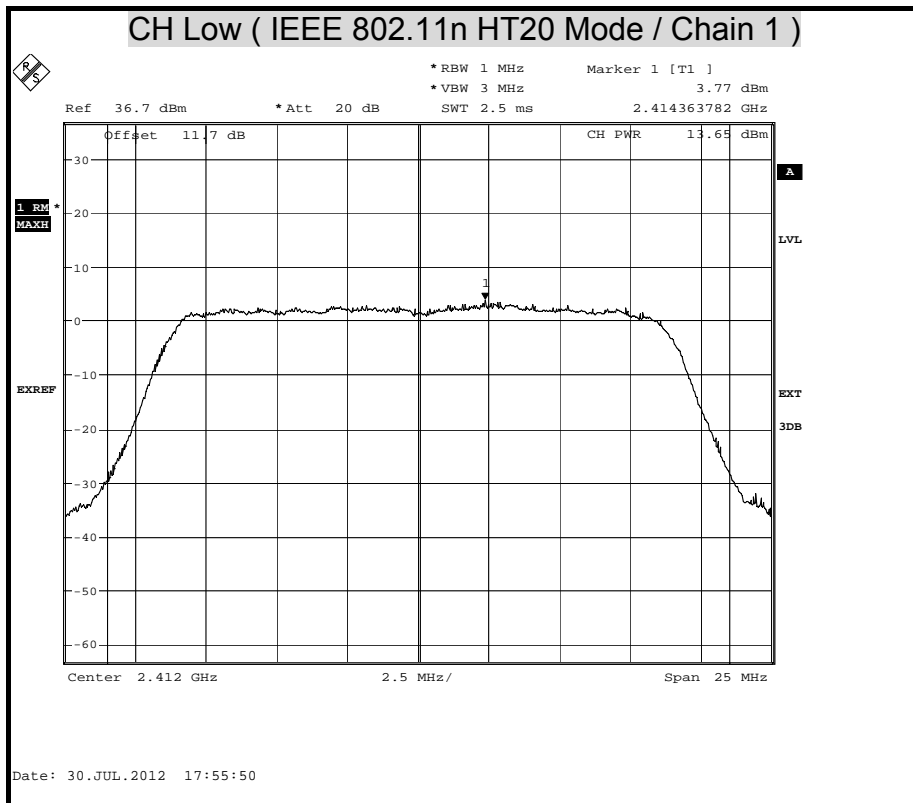

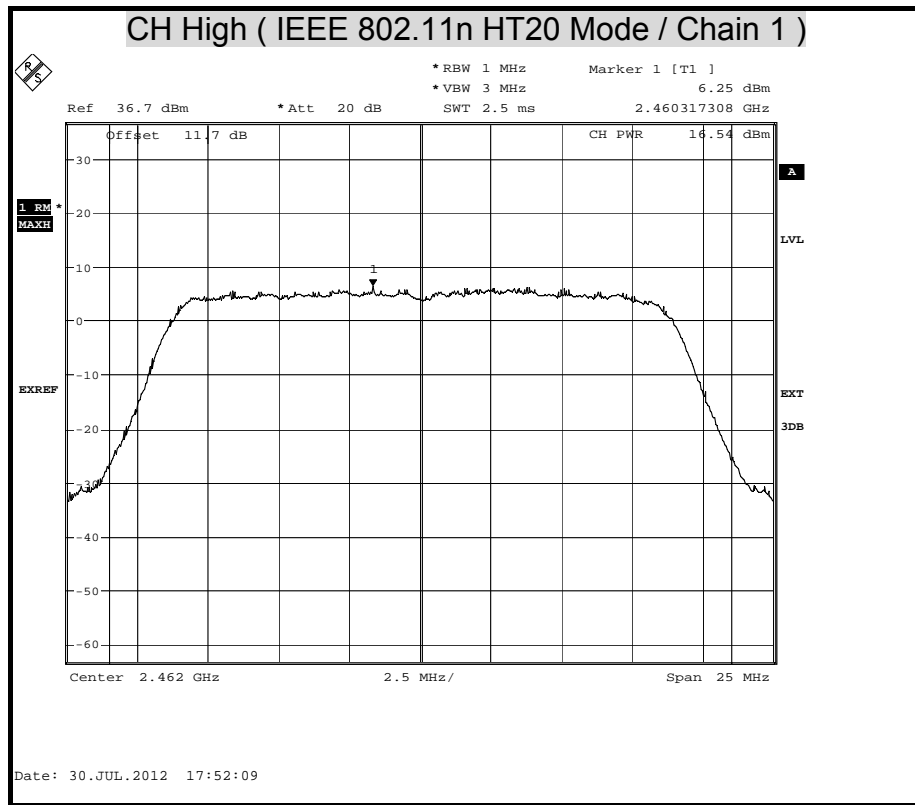

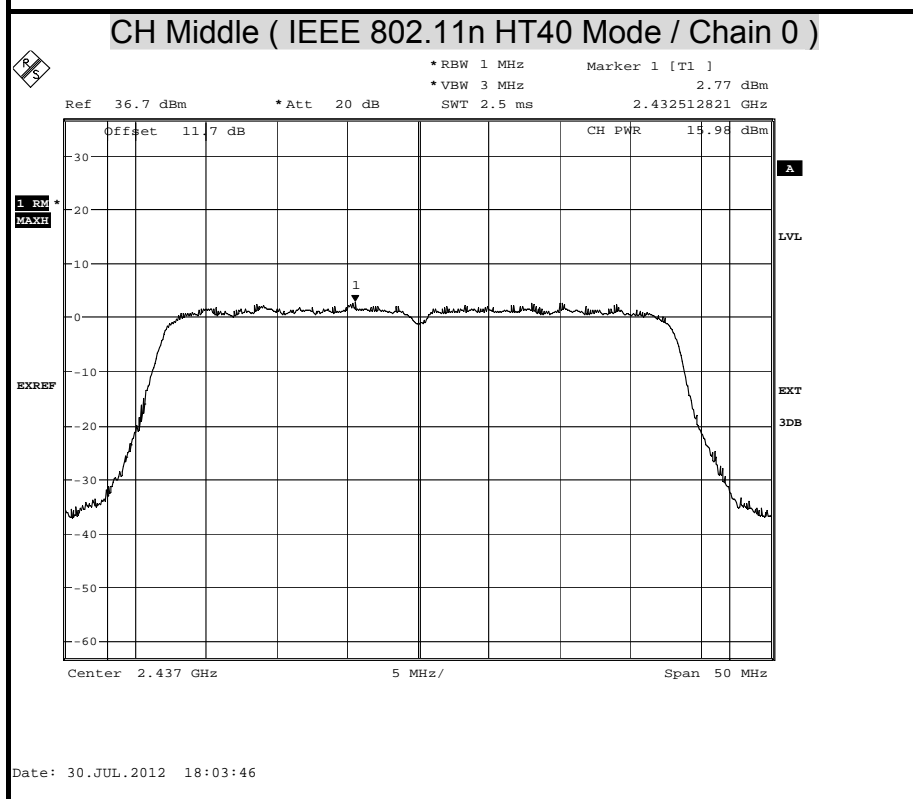
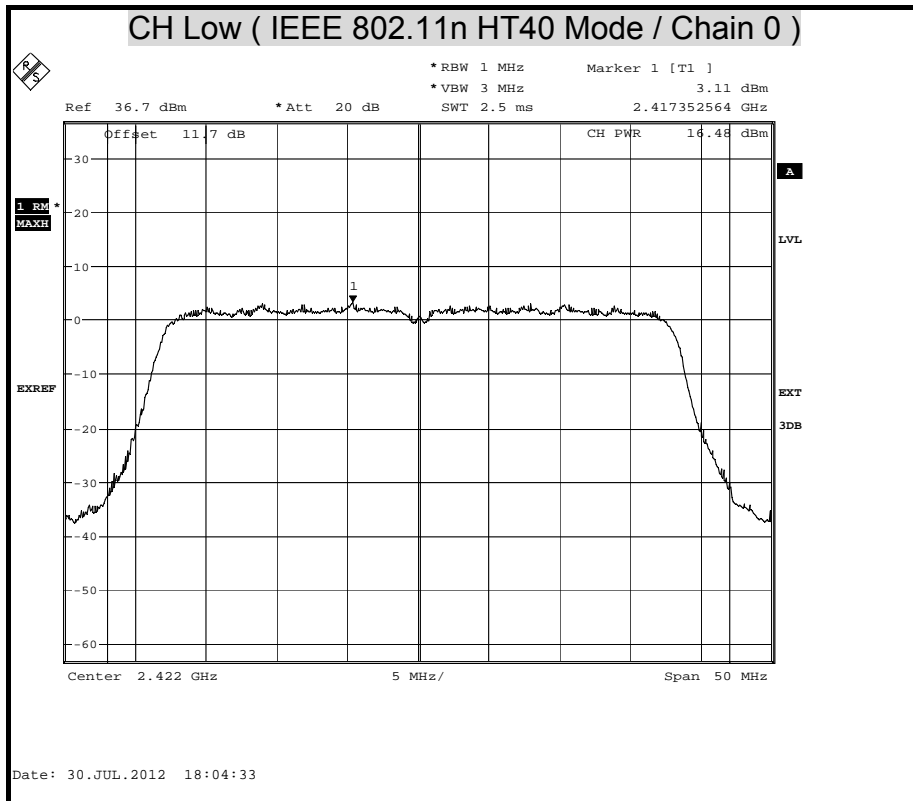

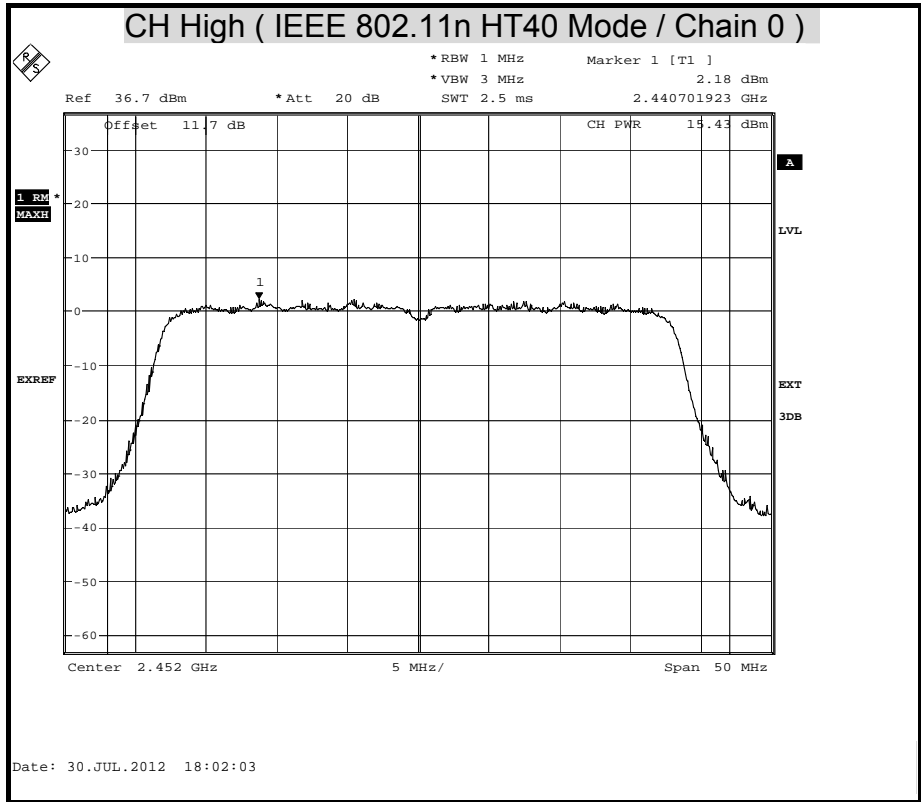

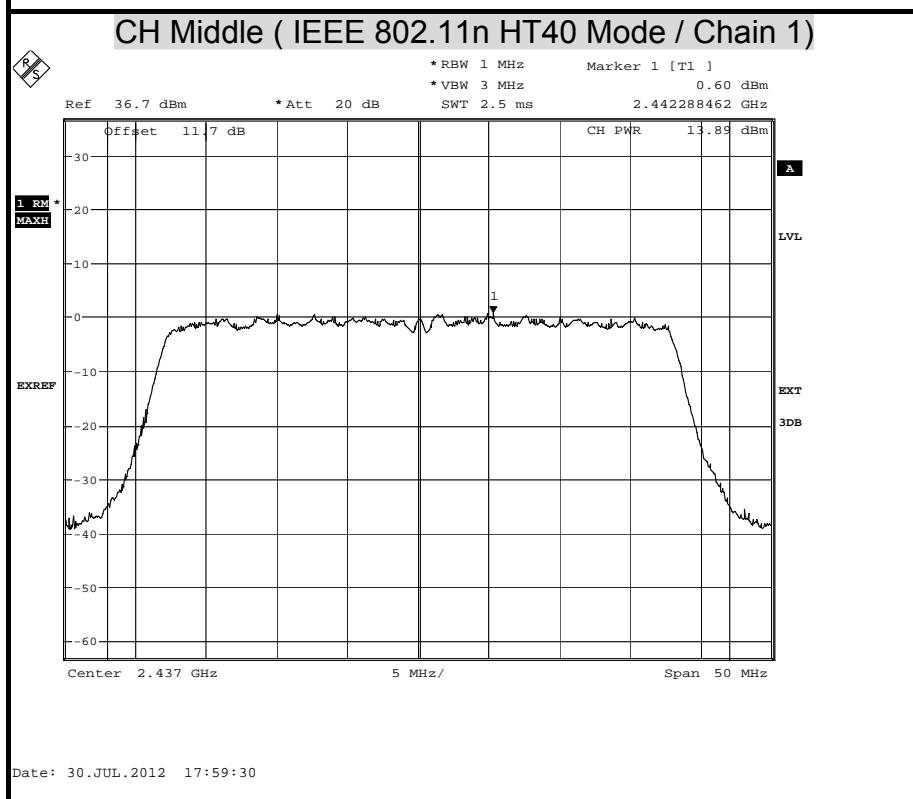
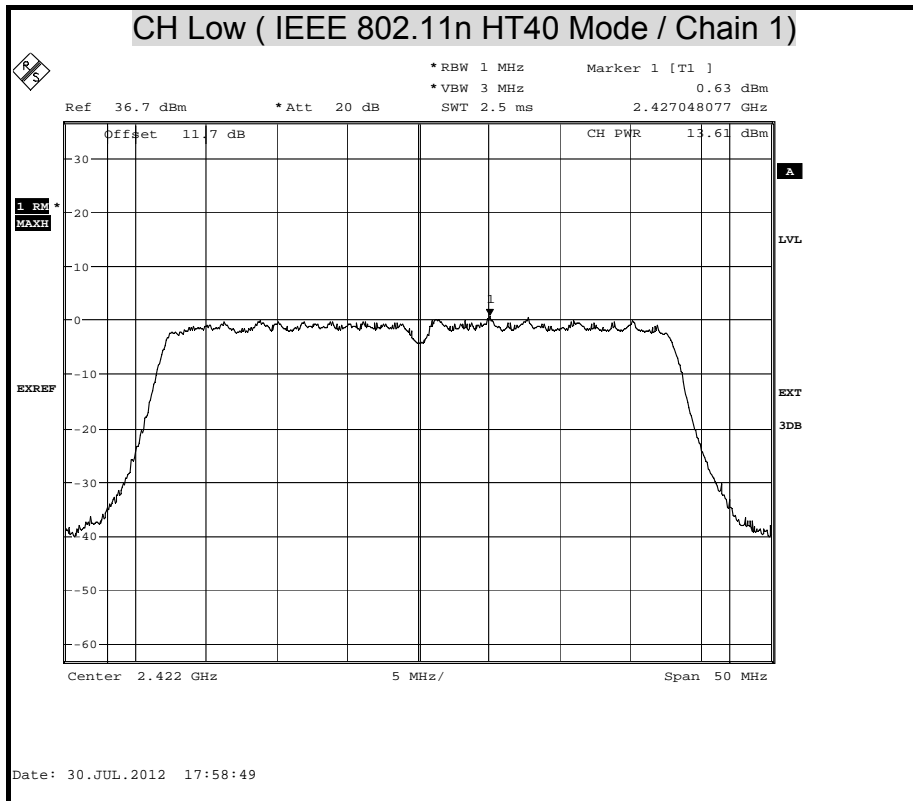

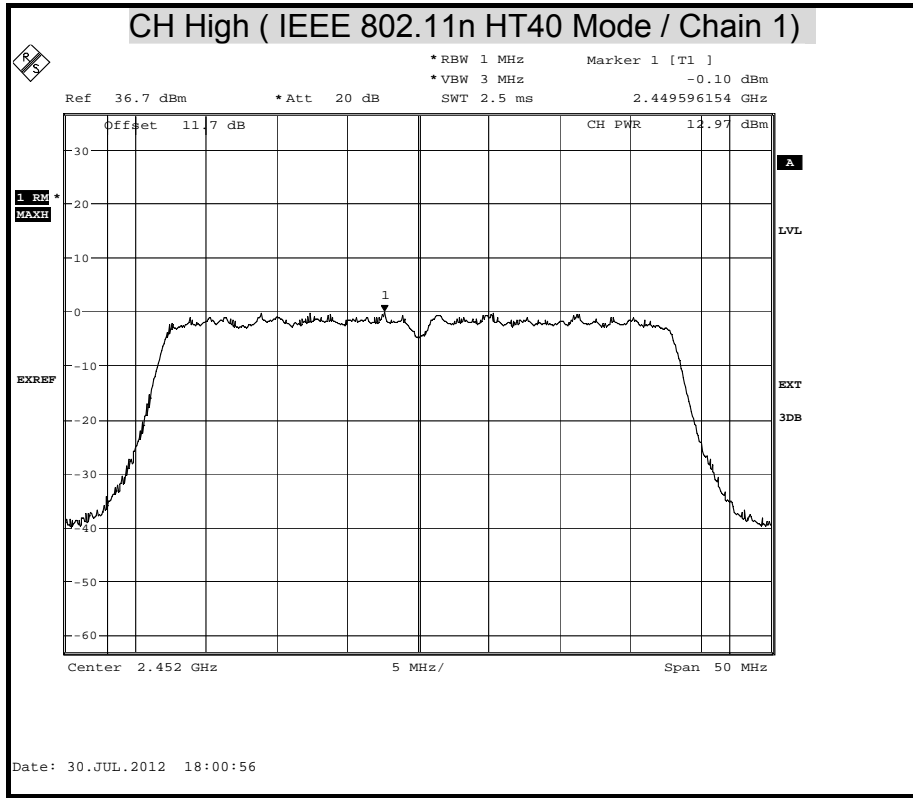



AVERAGE POWER (5G)

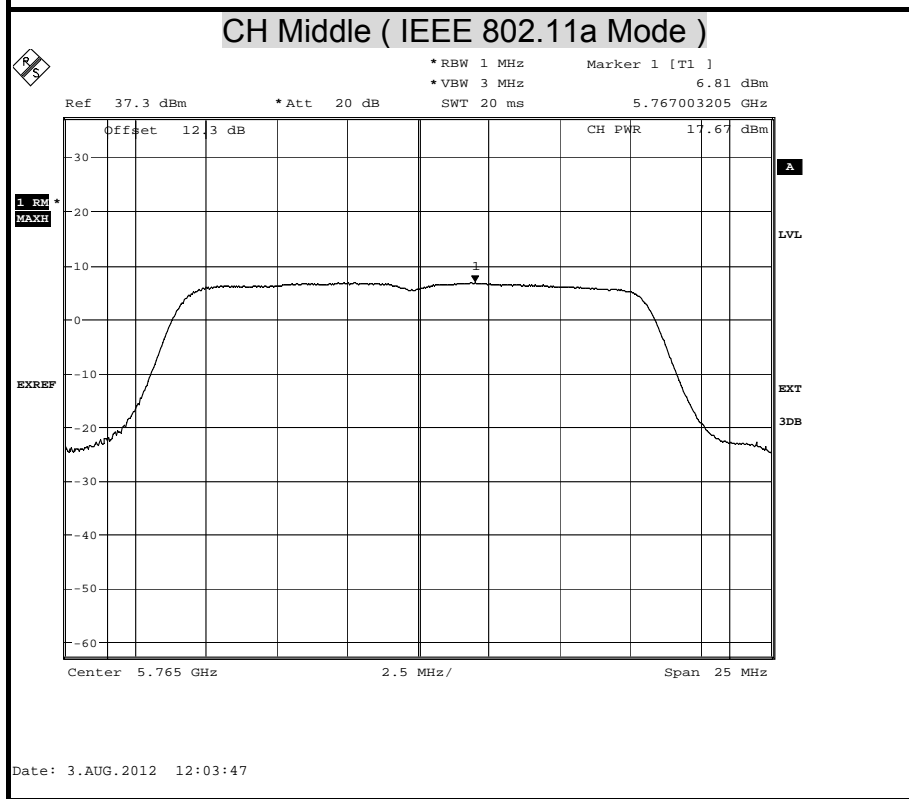
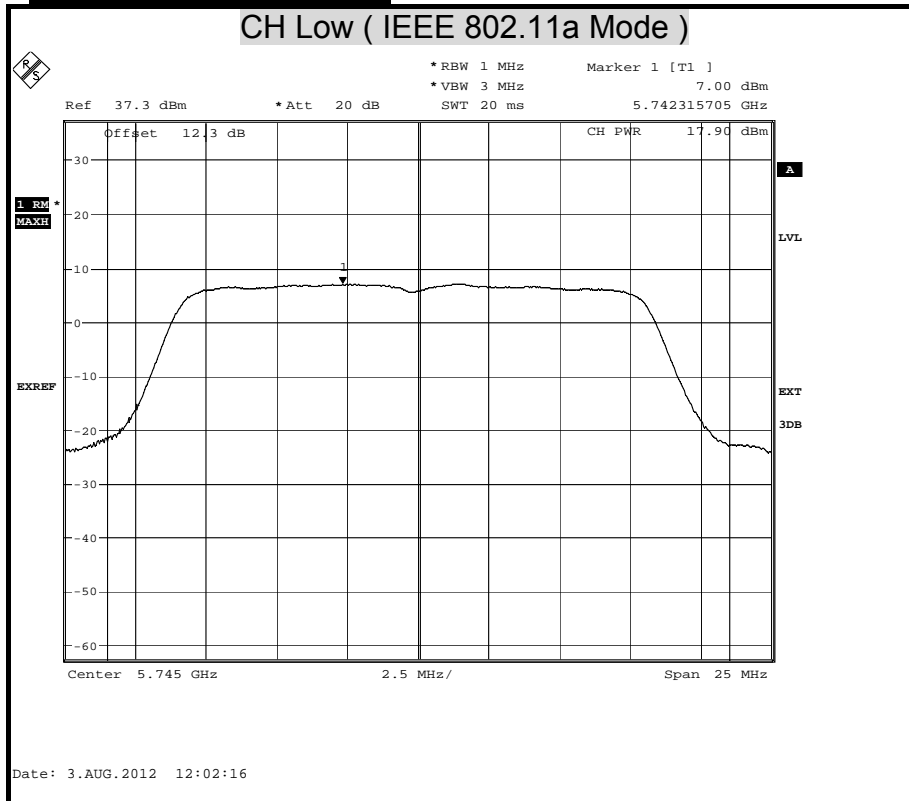

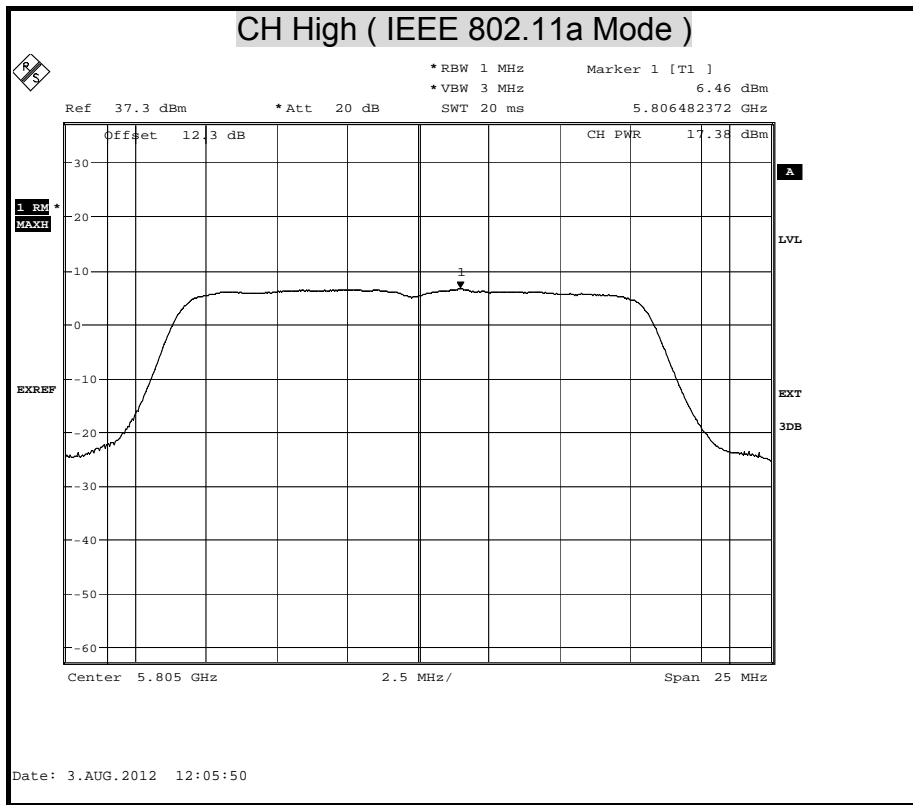

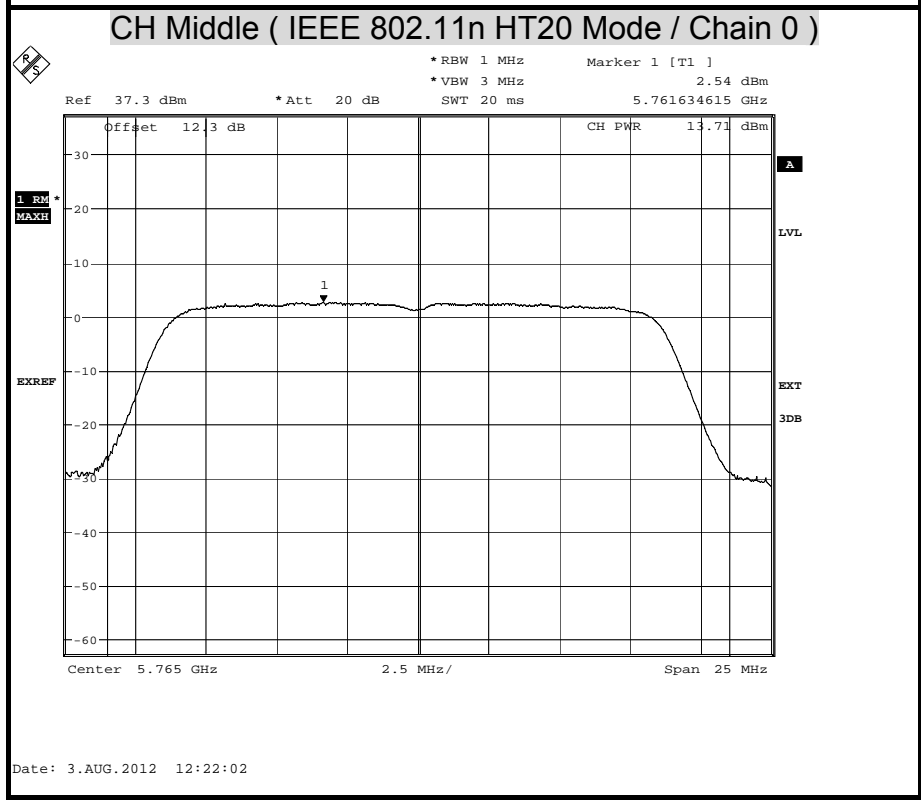
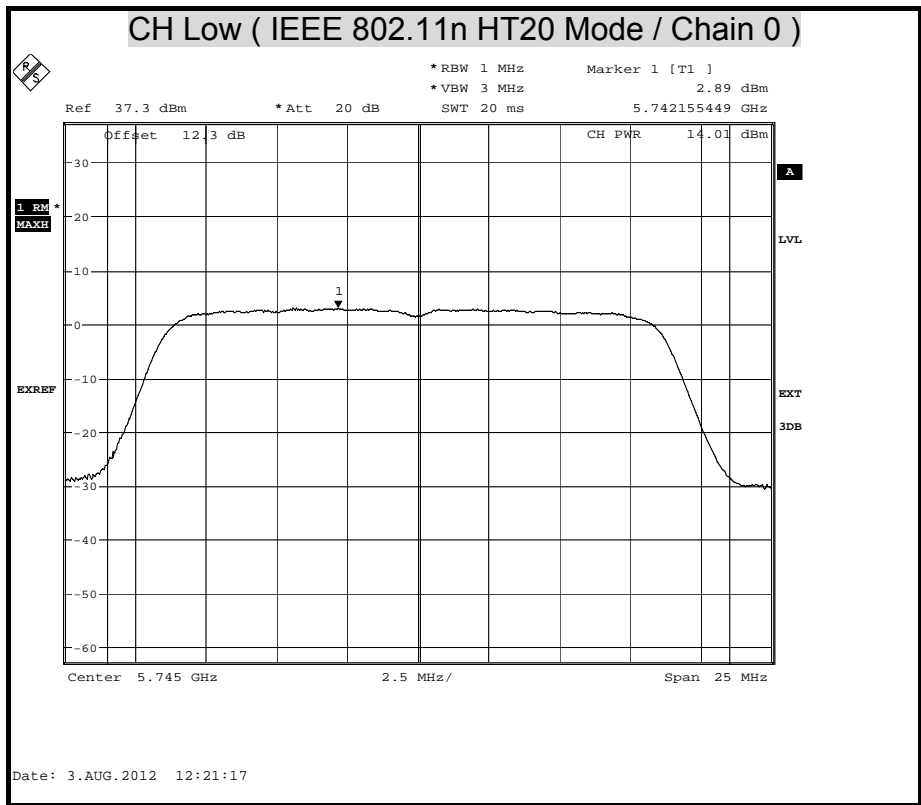

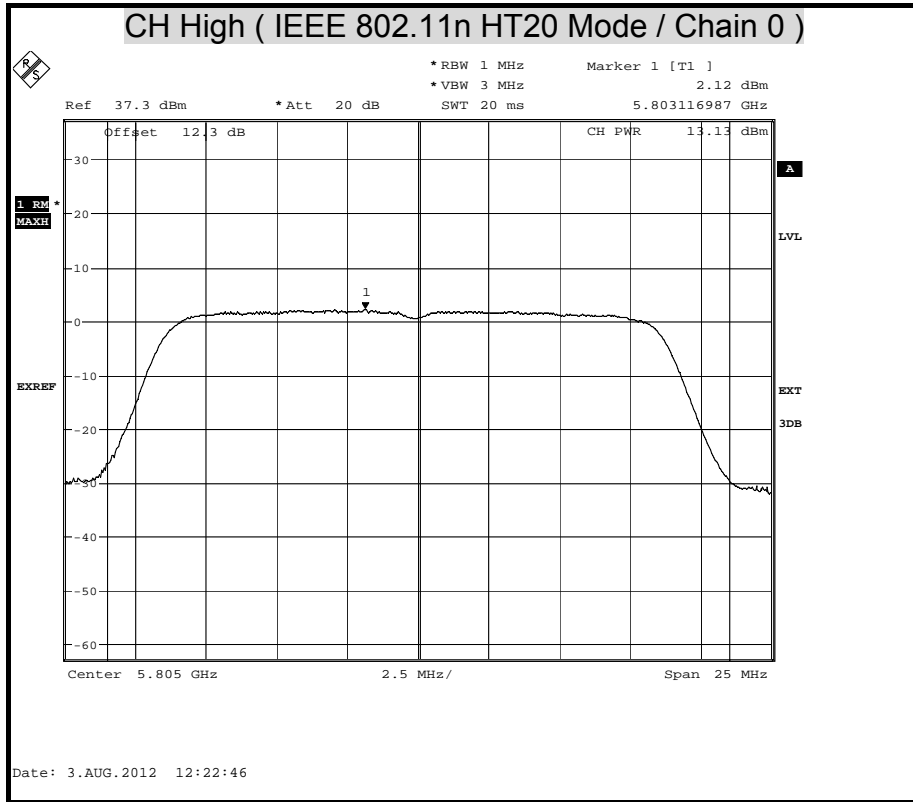

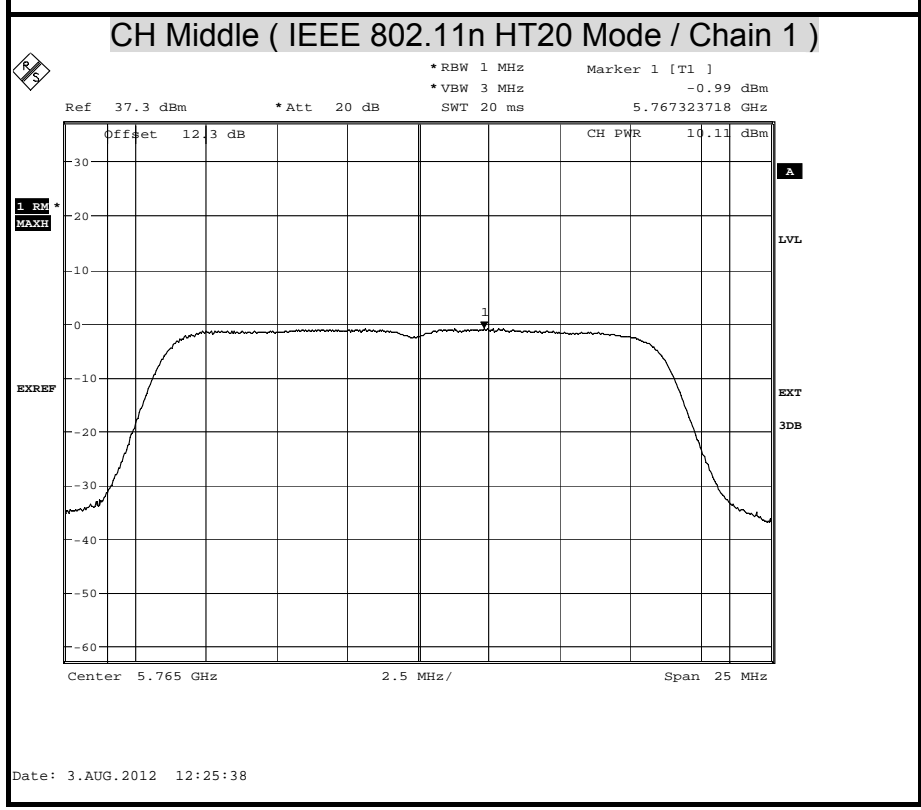
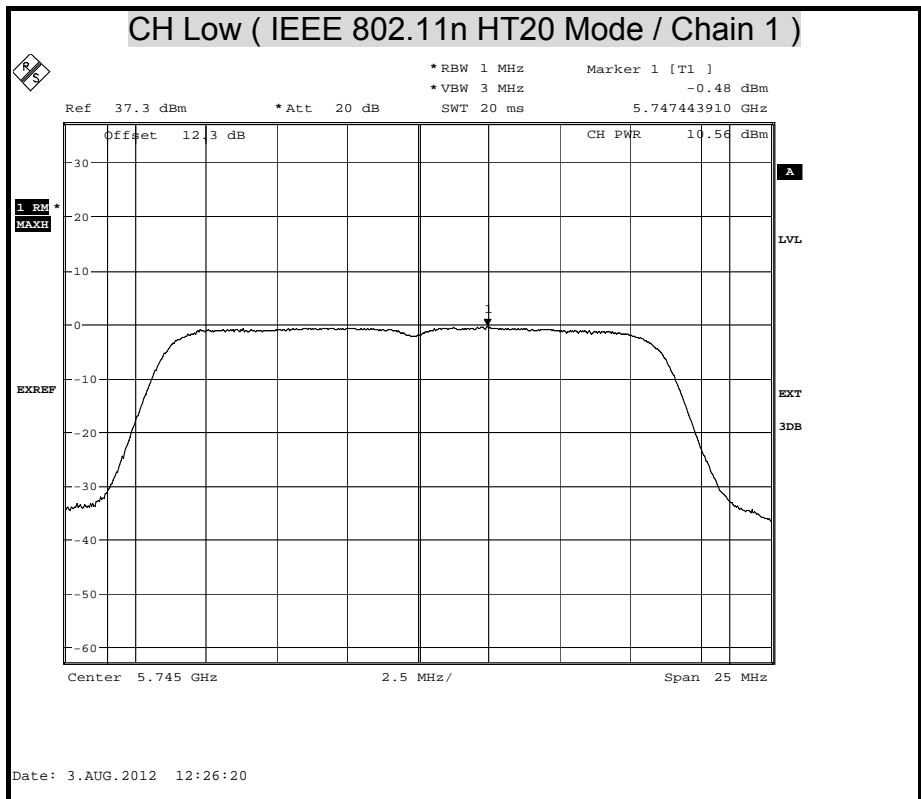

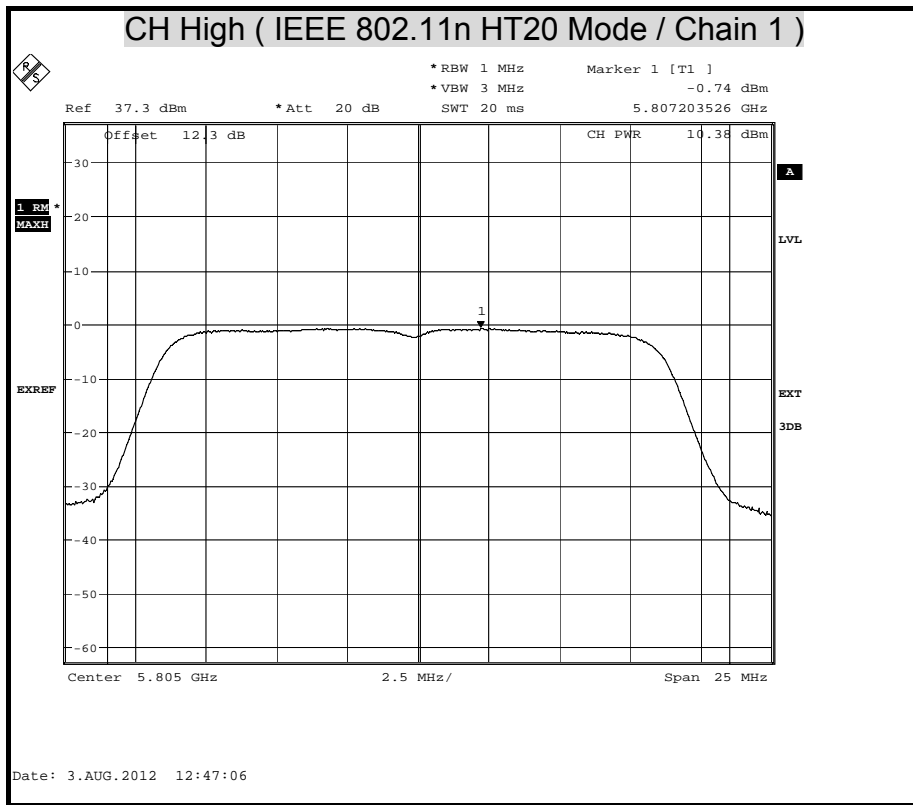

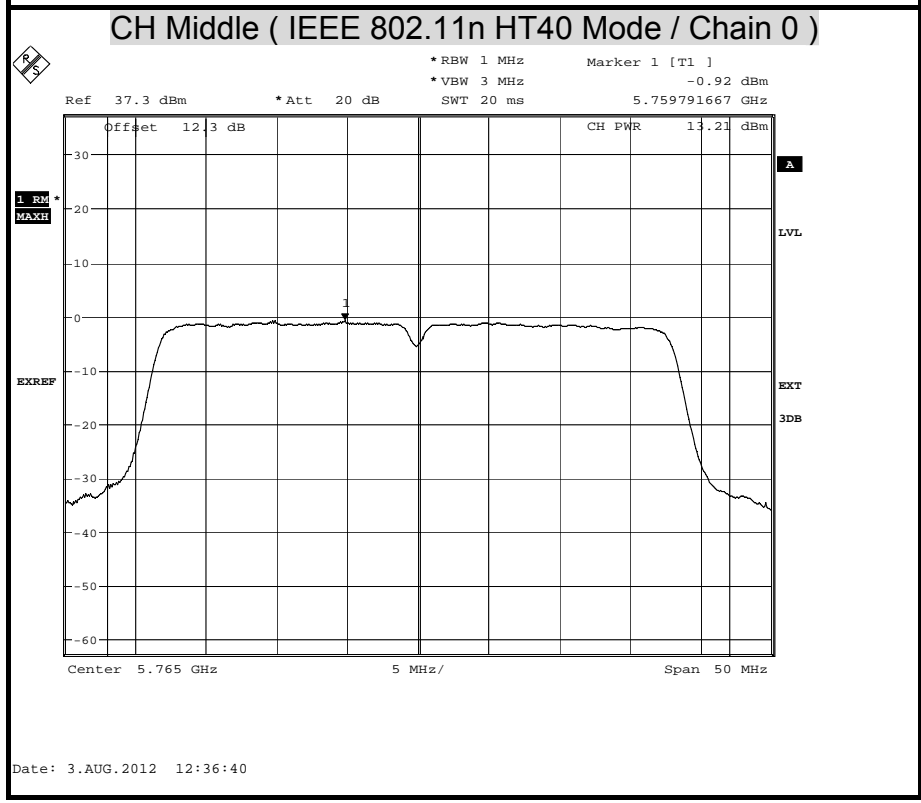
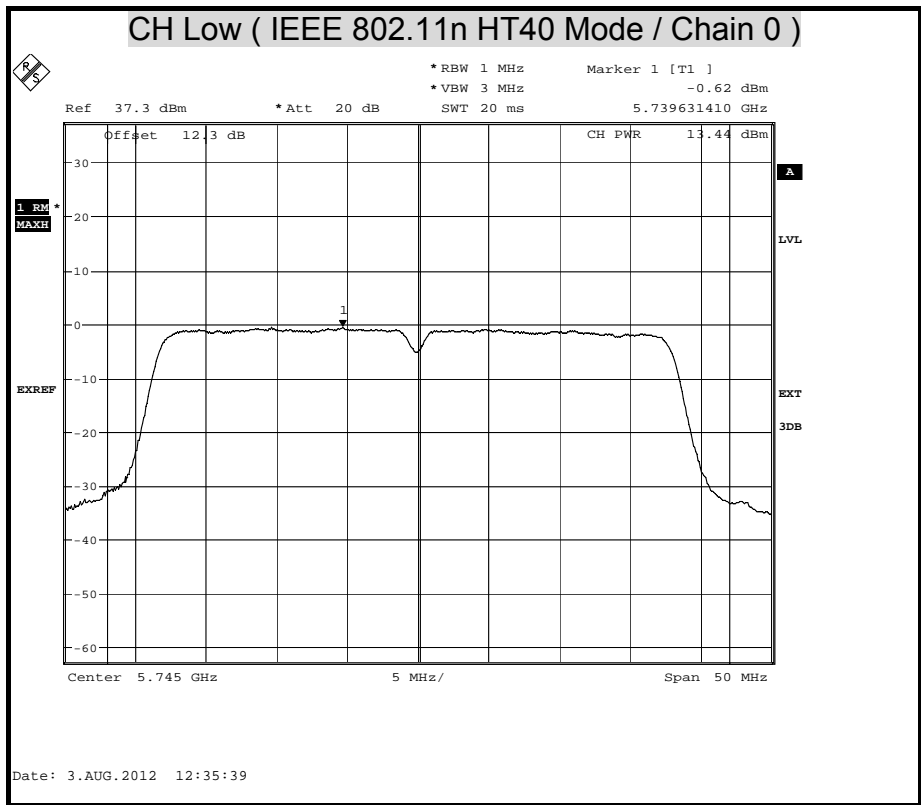

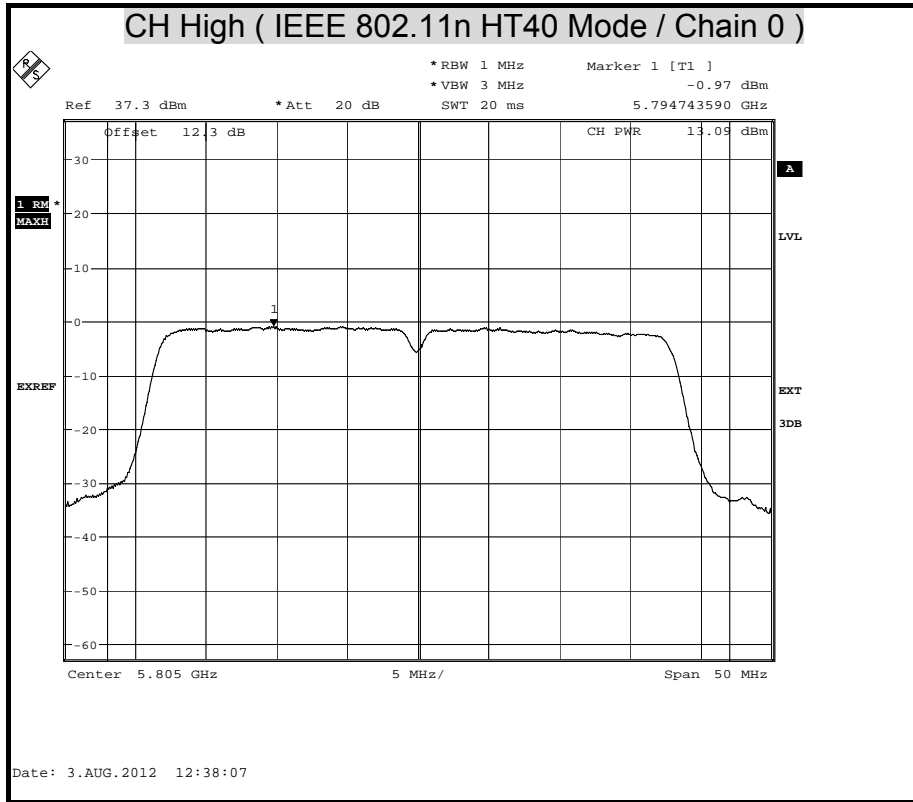

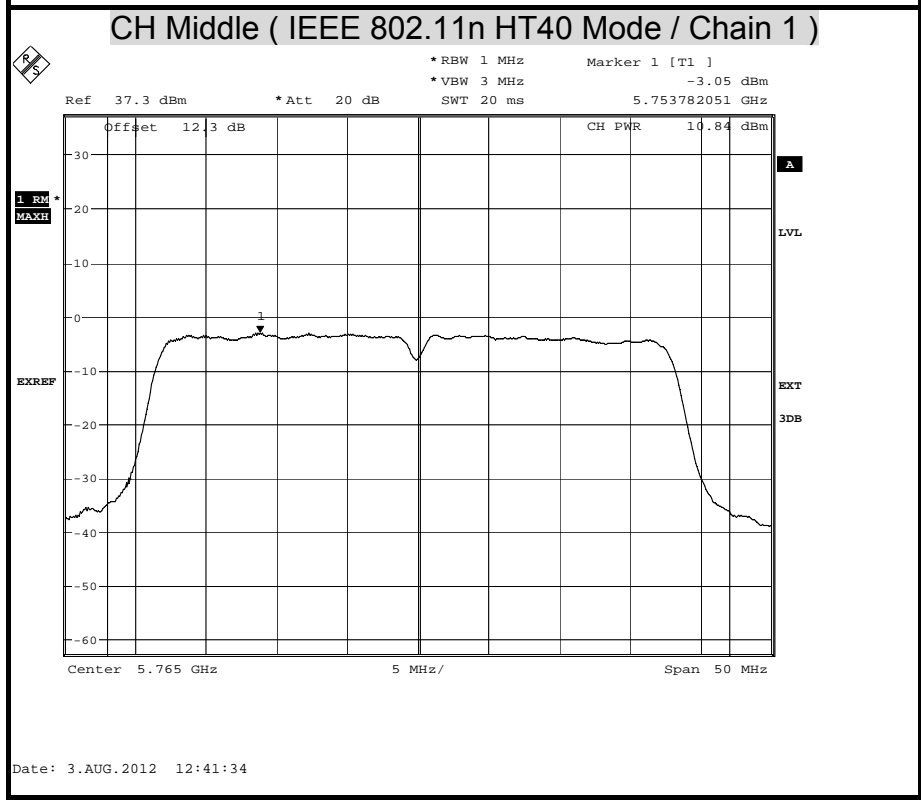
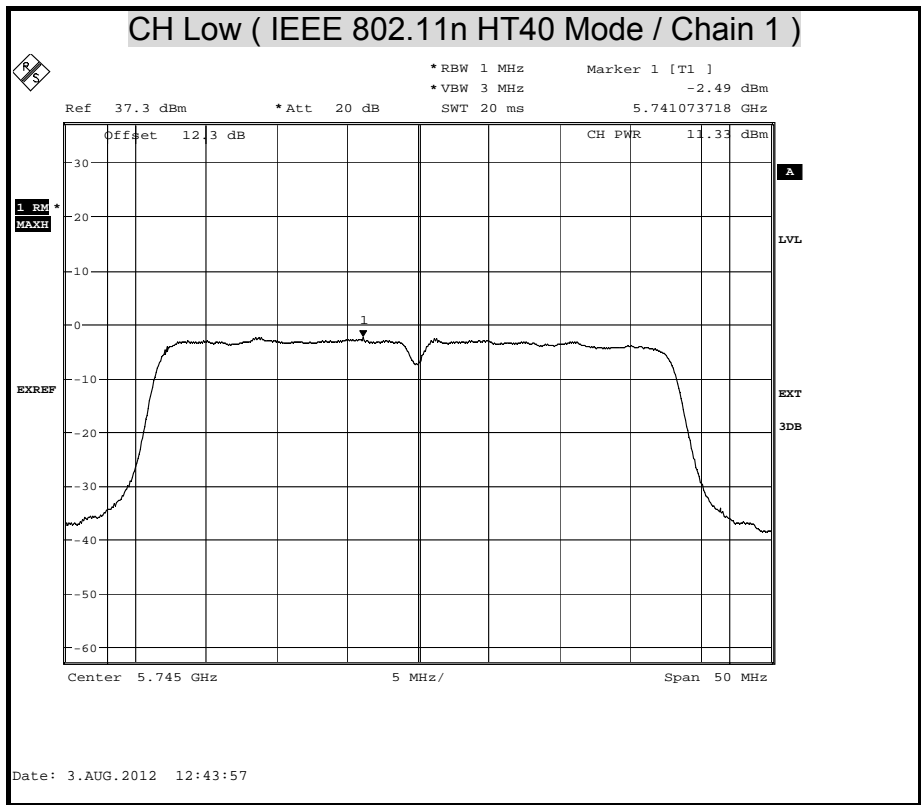

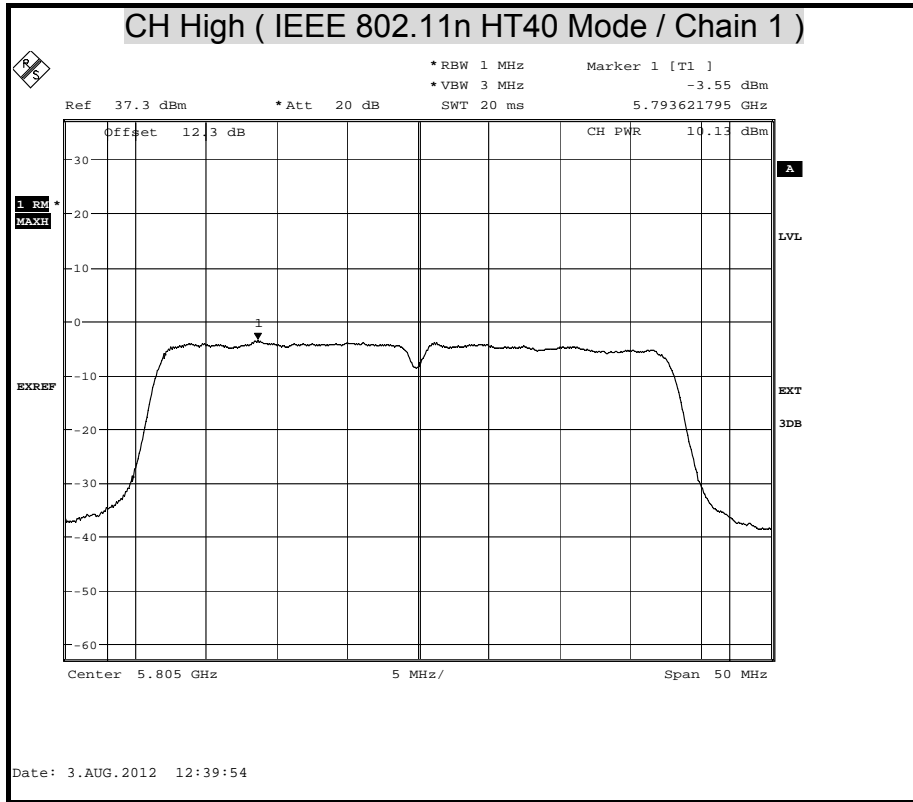



7.3 POWER SPECTRAL DENSITY

LIMITS

§ 15.247(e) For digitally modulated systems, the power spectral density conducted from the intentional radiator to the antenna shall not greater than 8 dBm in any 3 kHz band during any time interval of continuous transmission.

TEST EQUIPMENT

Name of Equipment	Manufacturer	Model	Serial Number	Calibration Due
Spectrum Analyzer	FSU	FSEK 30	835253/002	SEP. 29, 2012

Remark: Each piece of equipment is scheduled for calibration once a year.

TEST SETUP

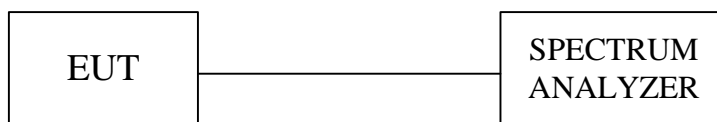

TEST PROCEDURE

The tests were performed in accordance with KDB 558074 5.3.1.

5.3.1 Measurement Procedure PKPSD:

1. Use this procedure when the maximum peak conducted output power in the fundamental emission is used to demonstrate compliance.
2. Set the RBW = 100 kHz.
3. Set the VBW ≥ 300 kHz.
4. Set the span to 5-30 % greater than the EBW.
5. Detector = peak.
6. Sweep time = auto couple.
7. Trace mode = max hold.
8. Allow trace to fully stabilize.
9. Use the peak marker function to determine the maximum power level in any 100 kHz band segment within the fundamental EBW.
10. Scale the observed power level to an equivalent value in 3 kHz by adjusting (reducing) the measured power by a bandwidth correction factor (BWCF) where $BWCF = 10\log(3\text{ kHz}/100\text{ kHz} = -15.2\text{ dB})$.
11. The resulting peak PSD level must be ≤ 8 dBm.



TEST RESULTS

IEEE 802.11b Mode

Channel	Frequency (MHz)	Reading (dBm)	BWCF (dB)	PPSD (dBm)	Limit (dBm)	Margin (dB)	Pass / Fail
Low	2412	9.86	-15.2	-5.34	8.00	-13.34	PASS
Middle	2437	11.07	-15.2	-4.13	8.00	-12.13	PASS
High	2462	11.31	-15.2	-3.89	8.00	-11.89	PASS

Remark:

1. At final test to get the worst-case emission at 1Mbps.
2. The cable assembly insertion loss of 12.3dB (including 10 dB pad and 2.3 dB cable) was Entered as an offset in the spectrum analyzer to allow for direct reading of power.

IEEE 802.11g Mode

Channel	Frequency (MHz)	Reading (dBm)	BWCF (dB)	PPSD (dBm)	Limit (dBm)	Margin (dB)	Pass / Fail
Low	2412	4.53	-15.2	-10.67	8.00	-18.67	PASS
Middle	2437	5.13	-15.2	-10.07	8.00	-18.07	PASS
High	2462	4.64	-15.2	-10.56	8.00	-18.56	PASS

Remark:

1. At final test to get the worst-case emission at 6Mbps.
2. The cable assembly insertion loss of 12.3dB (including 10 dB pad and 2.3 dB cable) was Entered as an offset in the spectrum analyzer to allow for direct reading of power.



Antenna Gain1: 3 dBi
 Antenna Gain2: 3 dBi
 Array Gain=: 6.01 = $10 \cdot \log \left((10^{3/10}) + (10^{3/10}) \right)$
 PPSD Limit: 7.99 = $8 - (6.01 - 6)$

IEEE 802.11n HT20 Mode

Channel	Frequency (MHz)	Reading Chain0 (dBm)	Reading Chain1 (dBm)	BWCF (dB)	PPSD Chain0 (dBm)	PPSD Chain1 (dBm)	PPSD Total (dBm)	Limit (dBm)	Margin (dB)	Pass / Fail
Low	2412	-0.3	-1.75	-15.2	-15.50	-16.95	-13.15	7.99	-21.14	PASS
Middle	2437	0.44	0.58	-15.2	-14.76	-14.62	-11.68	7.99	-19.67	PASS
High	2462	1.03	0.35	-15.2	-14.17	-14.85	-11.49	7.99	-19.48	PASS

Remark:

1. At final test to get the worst-case emission at 13Mbps.
2. The cable assembly insertion loss of 12.3dB (including 10 dB pad and 2.3 dB cable) was Entered as an offset in the spectrum analyzer to allow for direct reading of power.

IEEE 802.11n HT40 Mode

Channel	Frequency (MHz)	Reading Chain0 (dBm)	Reading Chain1 (dBm)	BWCF (dB)	PPSD Chain0 (dBm)	PPSD Chain1 (dBm)	PPSD Total (dBm)	Limit (dBm)	Margin (dB)	Pass / Fail
Low	2422	-2.04	-3.59	-15.2	-17.24	-18.79	-14.94	7.99	-22.93	PASS
Middle	2437	-2.4	-3.39	-15.2	-17.60	-18.59	-15.06	7.99	-23.05	PASS
High	2452	-2.84	-4.29	-15.2	-18.04	-19.49	-15.69	7.99	-23.68	PASS

Remark:

1. At final test to get the worst-case emission at 27Mbps.
2. The cable assembly insertion loss of 12.3dB (including 10 dB pad and 2.3 dB cable) was Entered as an offset in the spectrum analyzer to allow for direct reading of power.



Antenna Gain1: 5 dBi
 Antenna Gain2: 5 dBi
 Array Gain=: 8.01 = $10 \cdot \log \left((10^{5/10}) + (10^{5/10}) \right)$
 PPSD Limit: 5.99 = $8 - (8.01 - 6)$

IEEE 802.11a Mode

Channel	Frequency (MHz)	PPSD (dBm)	Limit (dBm)	Margin (dB)	Result
Low	5745	3.40	8.00	-4.60	PASS
Middle	5765	3.04		-4.96	PASS
High	5805	2.55		-5.45	PASS

Remark:

1. At final test to get the worst-case emission at 6Mbps.
2. The cable assembly insertion loss of 12.3dB (including 10 dB pad and 2.3 dB cable) was Entered as an offset in the spectrum analyzer to allow for direct reading of power.

IEEE 802.11n HT20 Mode

Channel	Frequency (MHz)	PPSD Chain0 (dBm)	PPSD Chain1 (dBm)	PPSD (dBm)	Limit (dBm)	Margin (dB)	Result
Low	5745	-1.30	-2.68	1.07	5.99	-4.92	PASS
Middle	5765	-0.58	-3.33	1.27		-4.72	PASS
High	5805	-1.19	-3.96	0.65		-5.34	PASS

Remark:

1. At final test to get the worst-case emission at 13Mbps.
2. The cable assembly insertion loss of 12.3dB (including 10 dB pad and 2.3 dB cable) was Entered as an offset in the spectrum analyzer to allow for direct reading of power.

IEEE 802.11n HT40 Mode

Channel	Frequency (MHz)	PPSD Chain0 (dBm)	PPSD Chain1 (dBm)	PPSD (dBm)	Limit (dBm)	Margin (dB)	Result
Low	5745	-7.45	-5.43	-3.31	5.99	-9.30	PASS
Middle	5765	-8.00	-5.87	-3.80		-9.79	PASS
High	5805	-8.44	-6.53	-4.37		-10.36	PASS

Remark:

1. At final test to get the worst-case emission at 27Mbps.
2. The cable assembly insertion loss of 12.3dB (including 10 dB pad and 2.3 dB cable) was Entered as an offset in the spectrum analyzer to allow for direct reading of power.



POWER SPECTRAL DENSITY (2.4G)

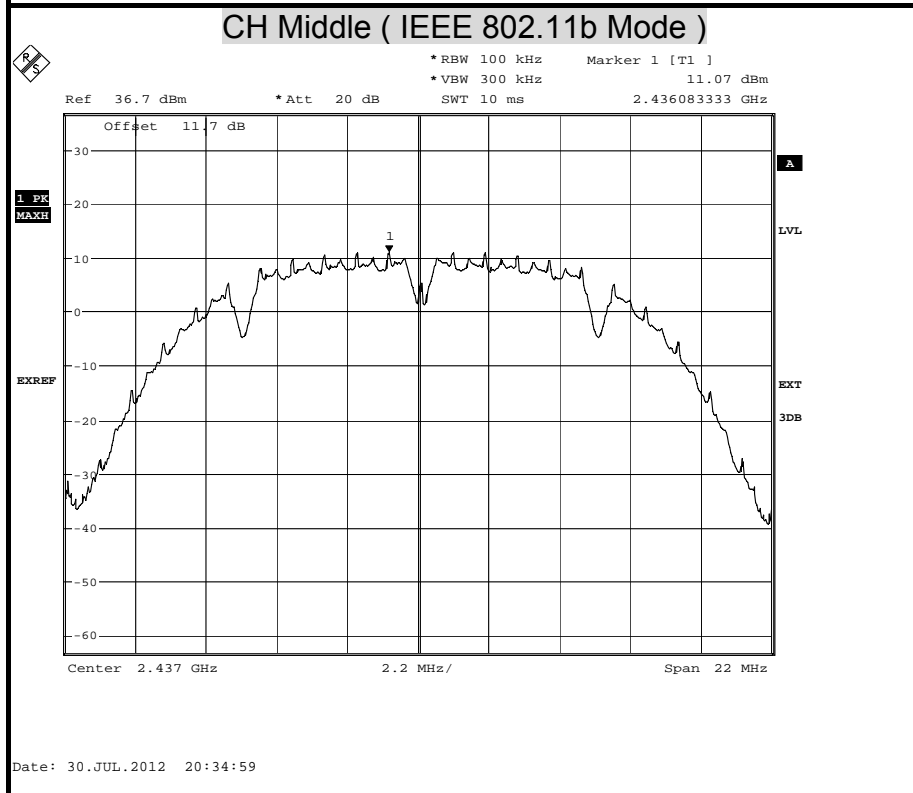
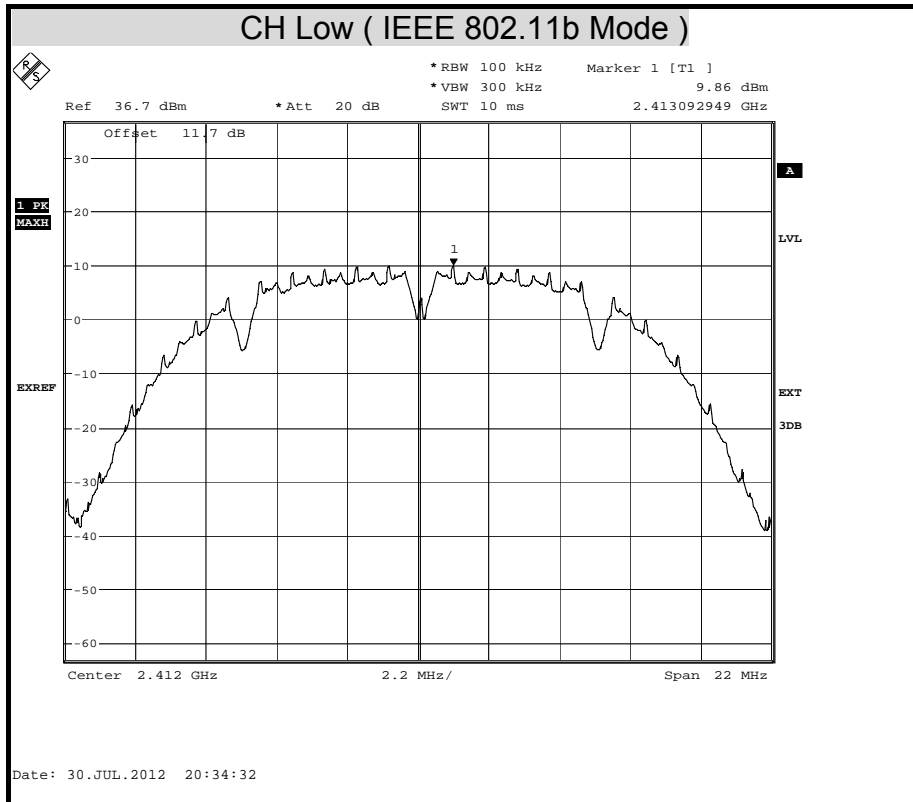

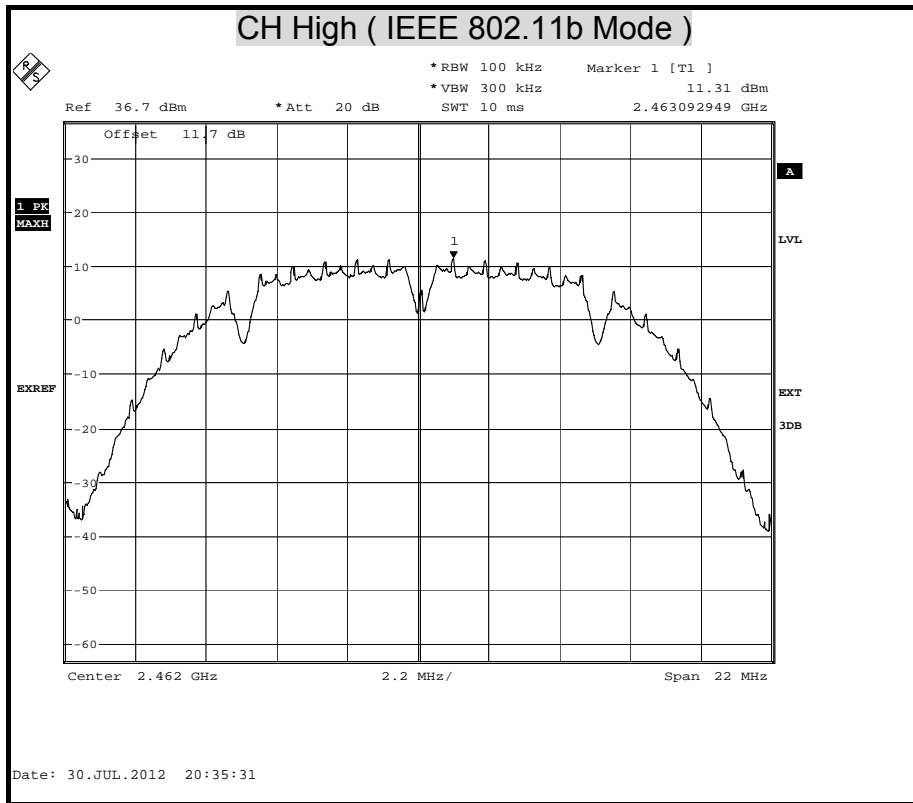

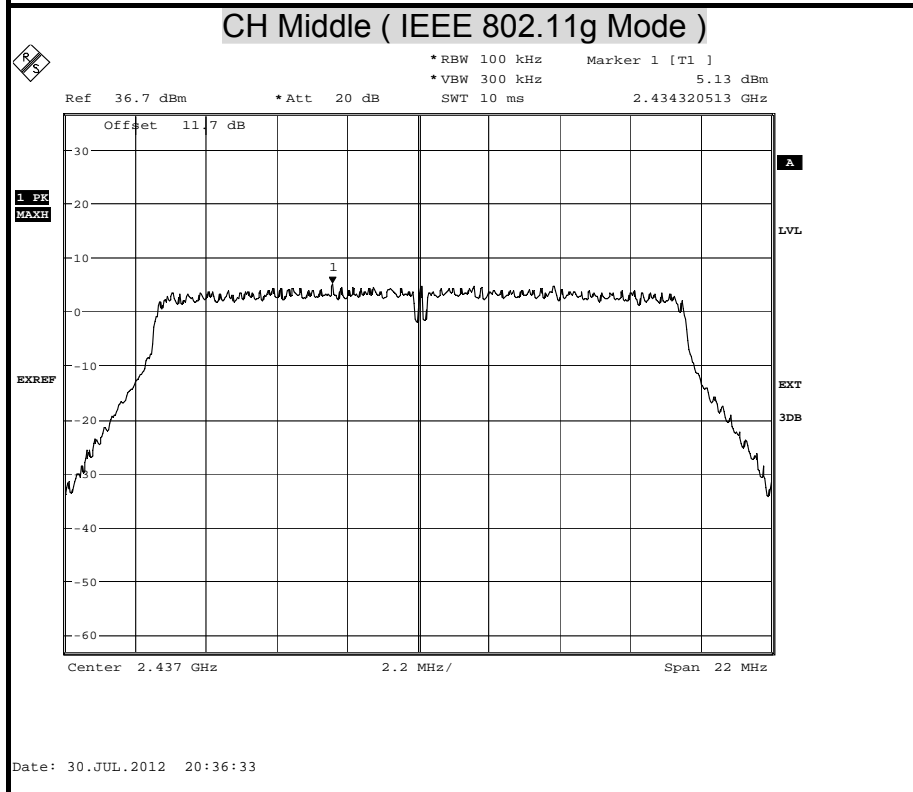
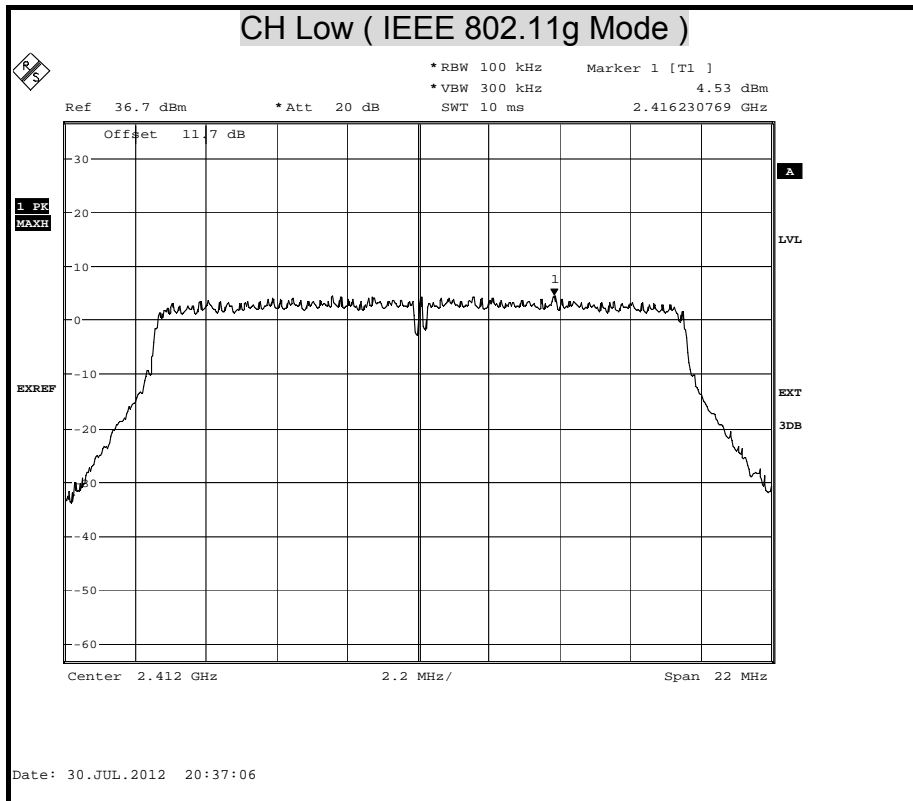

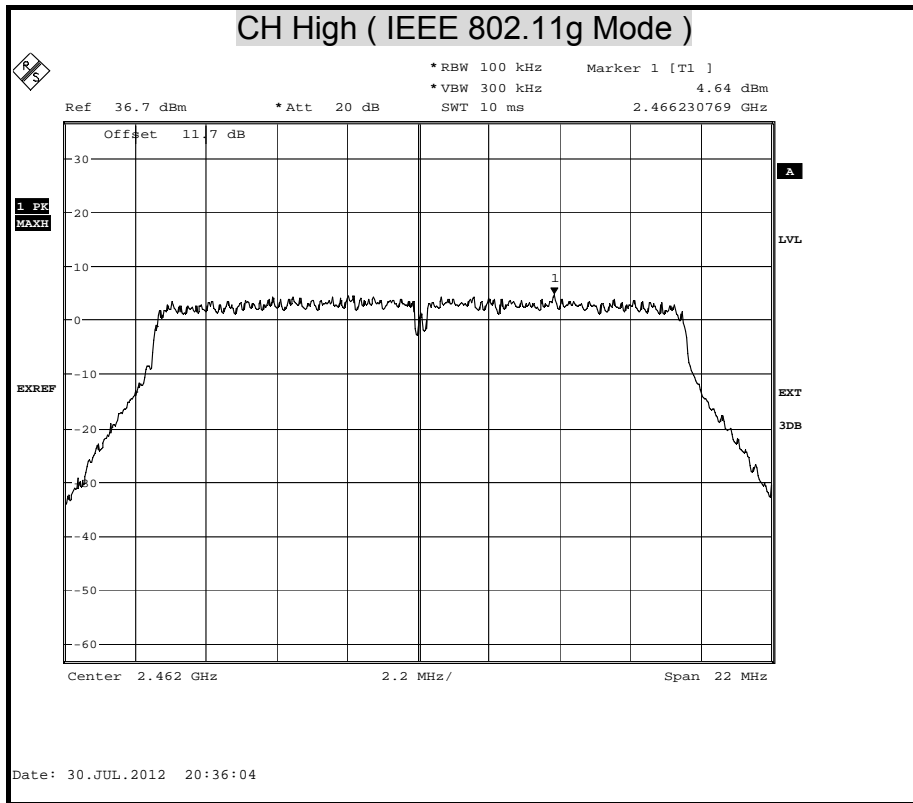

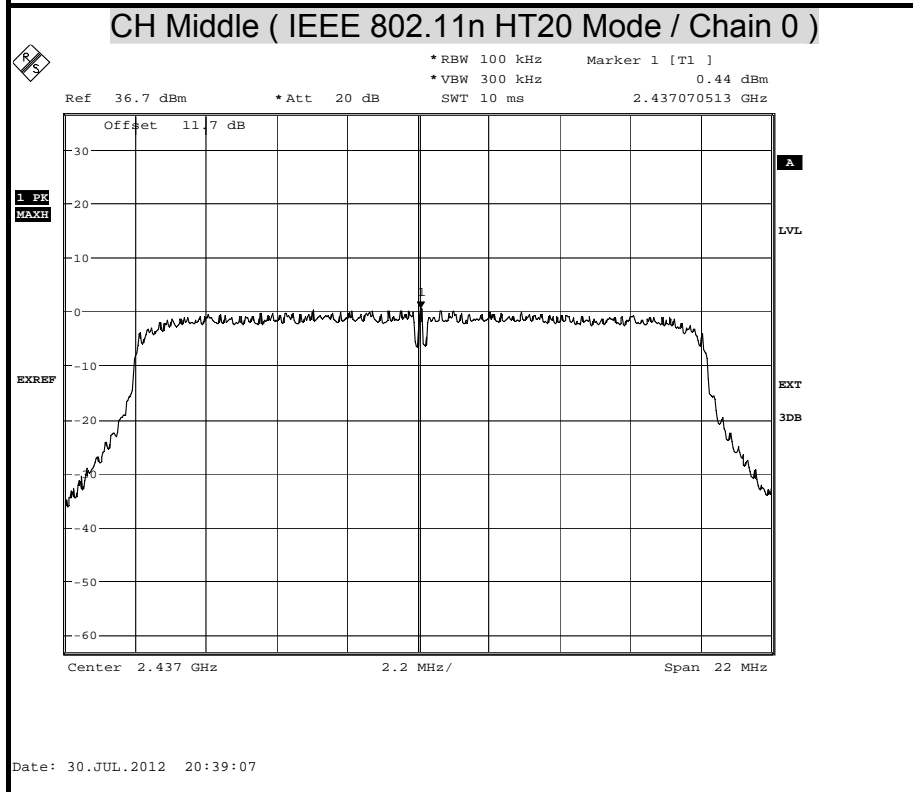
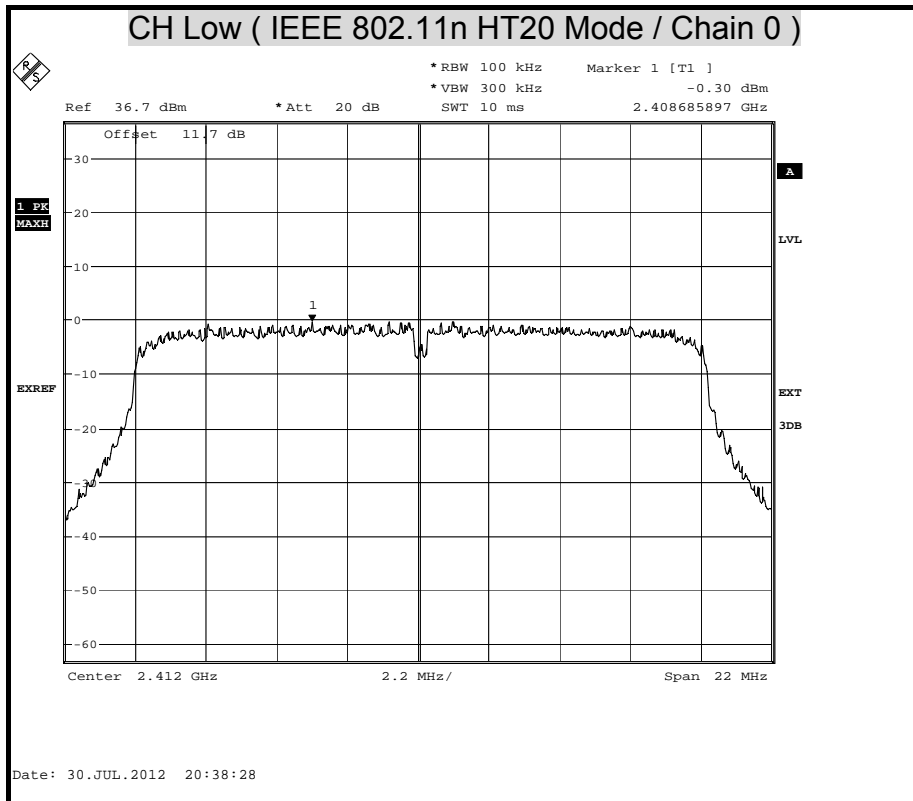

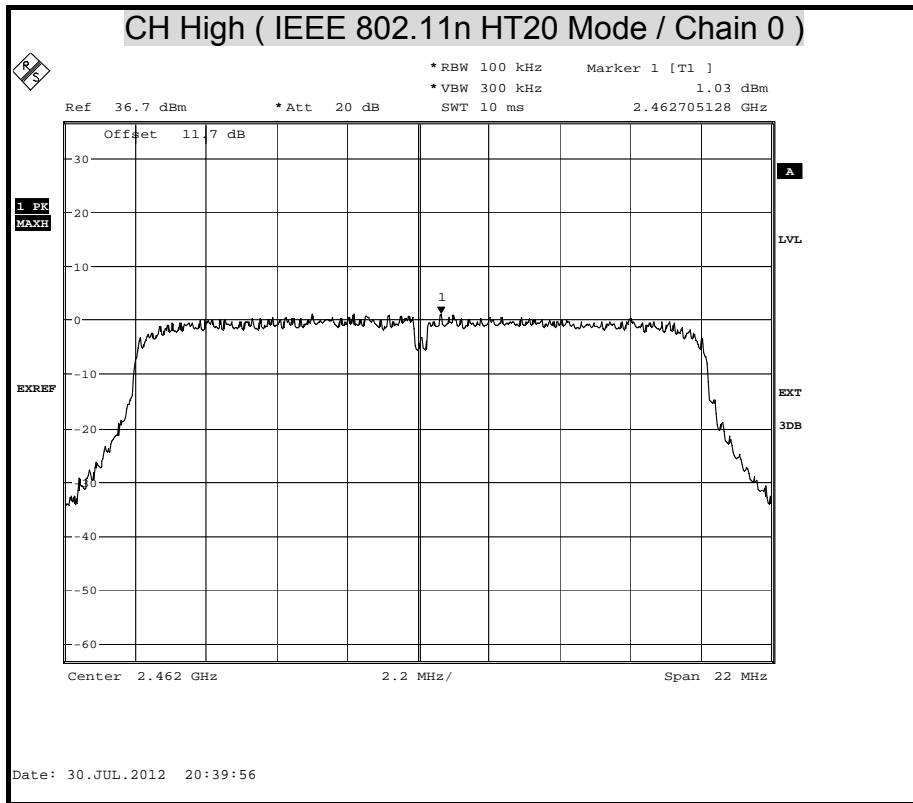

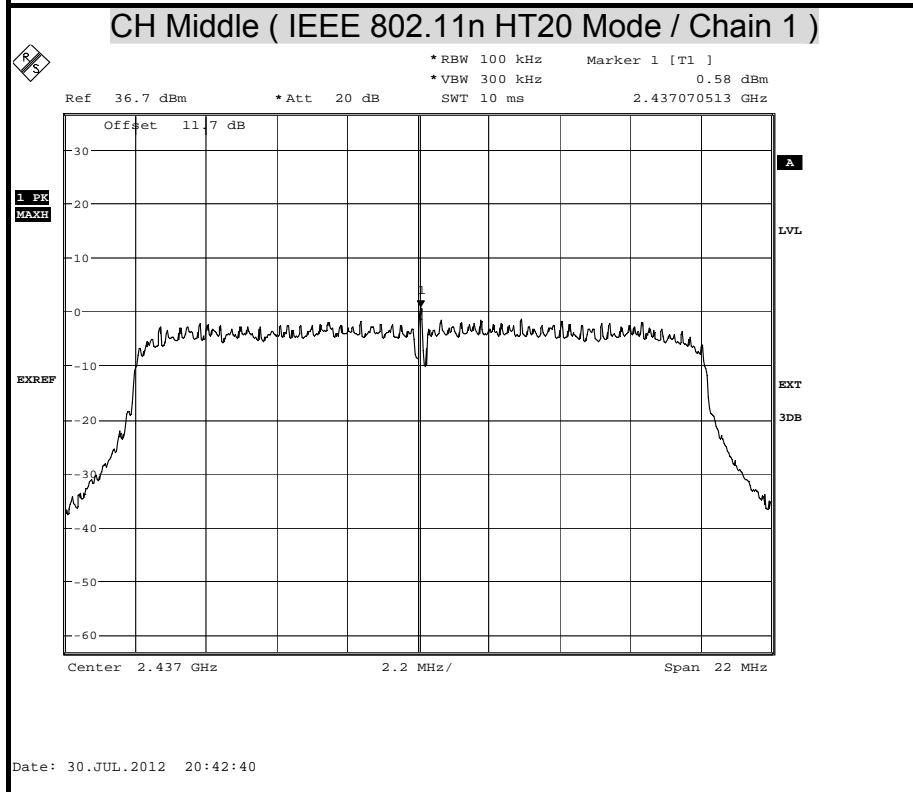
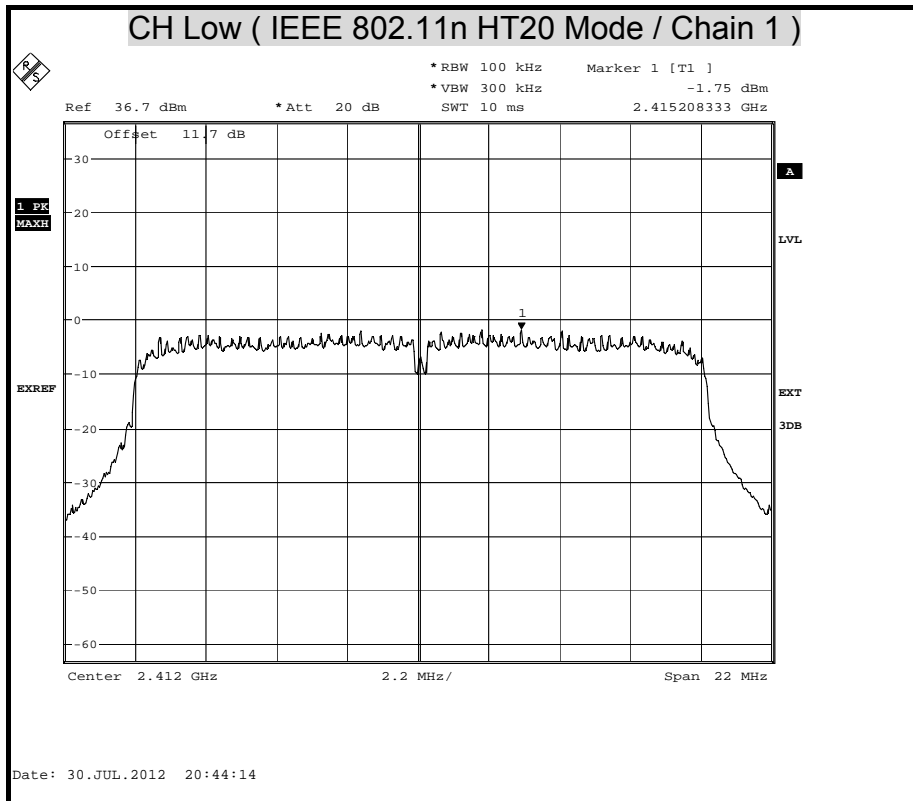

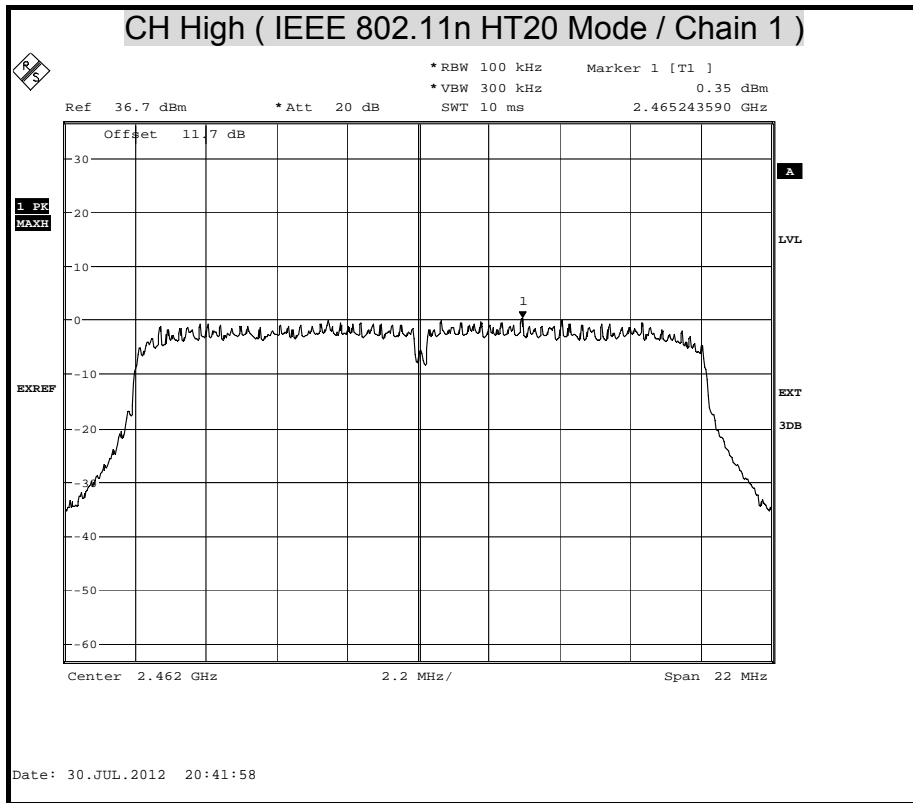

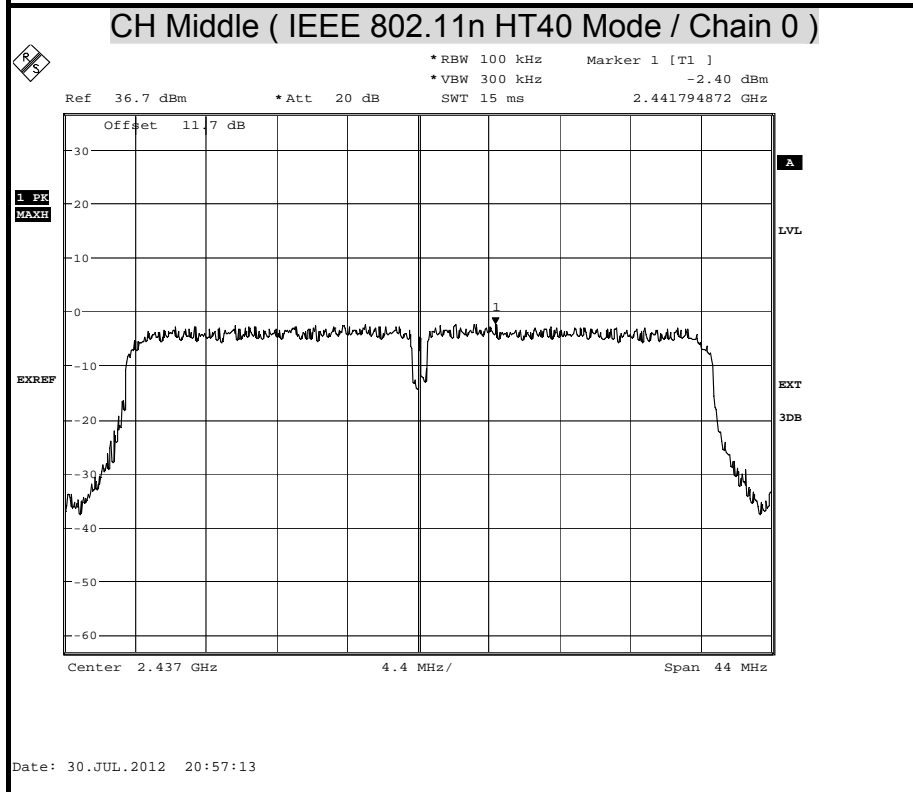
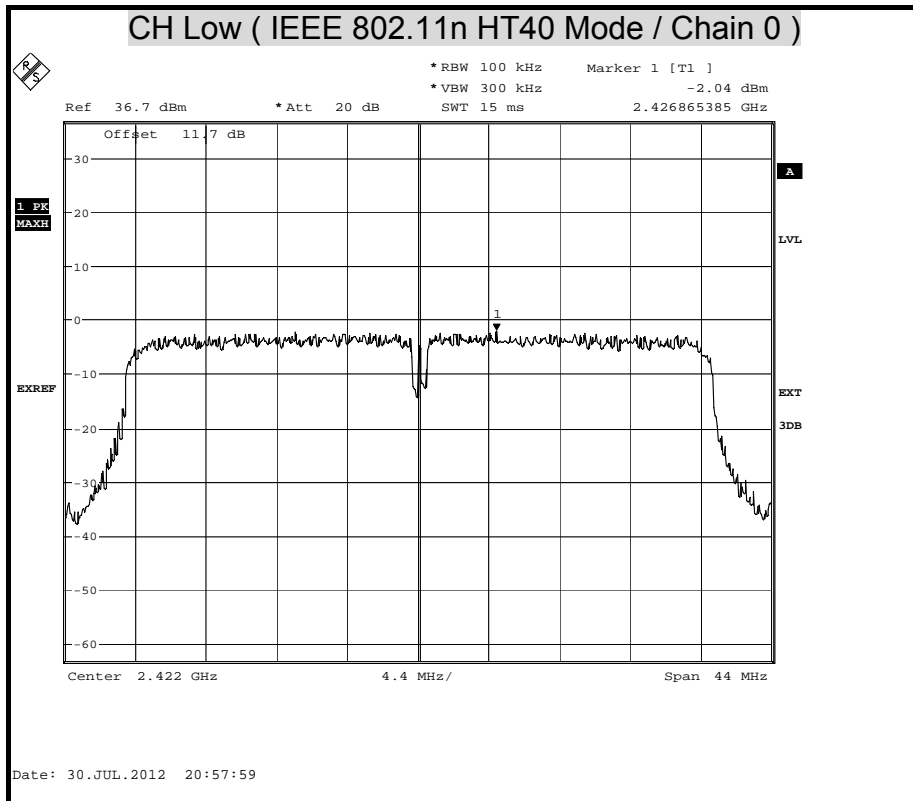

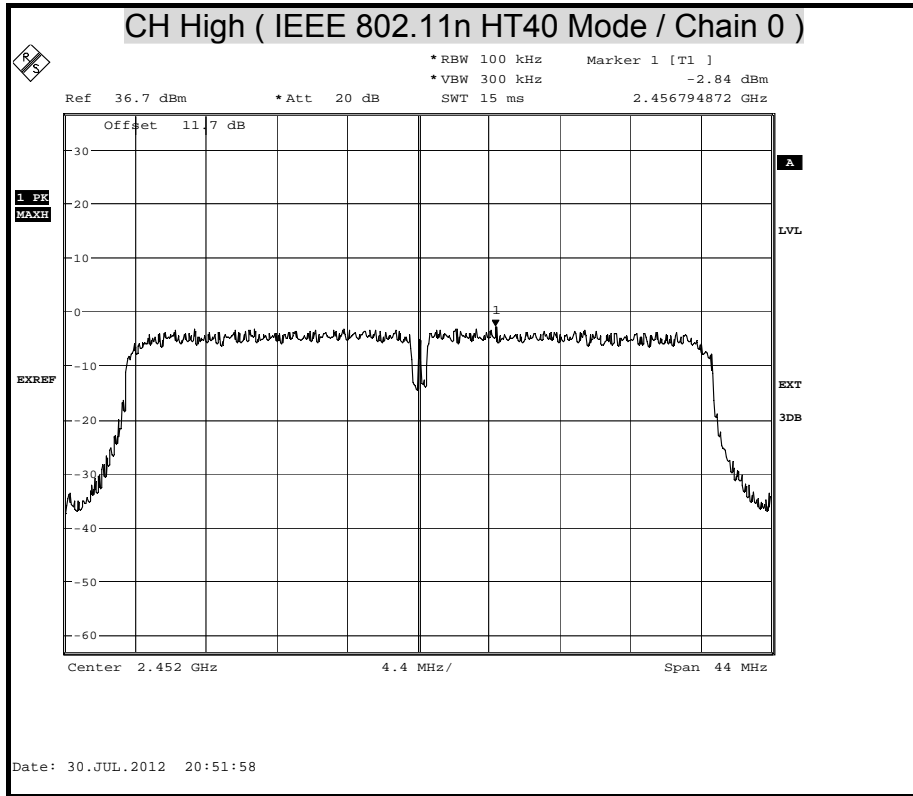

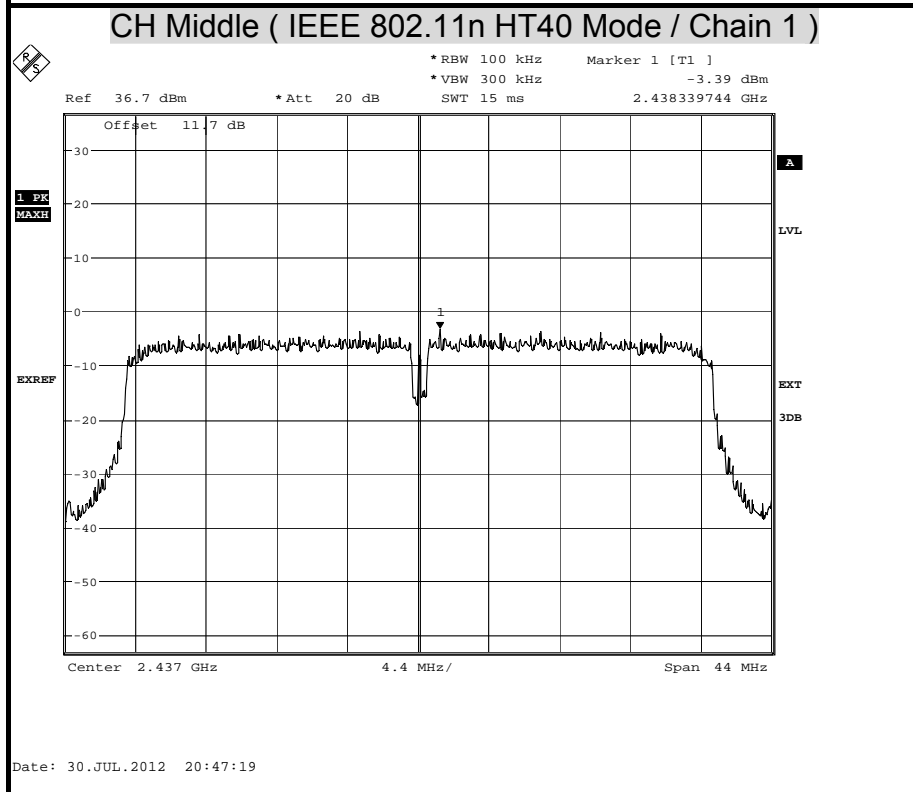
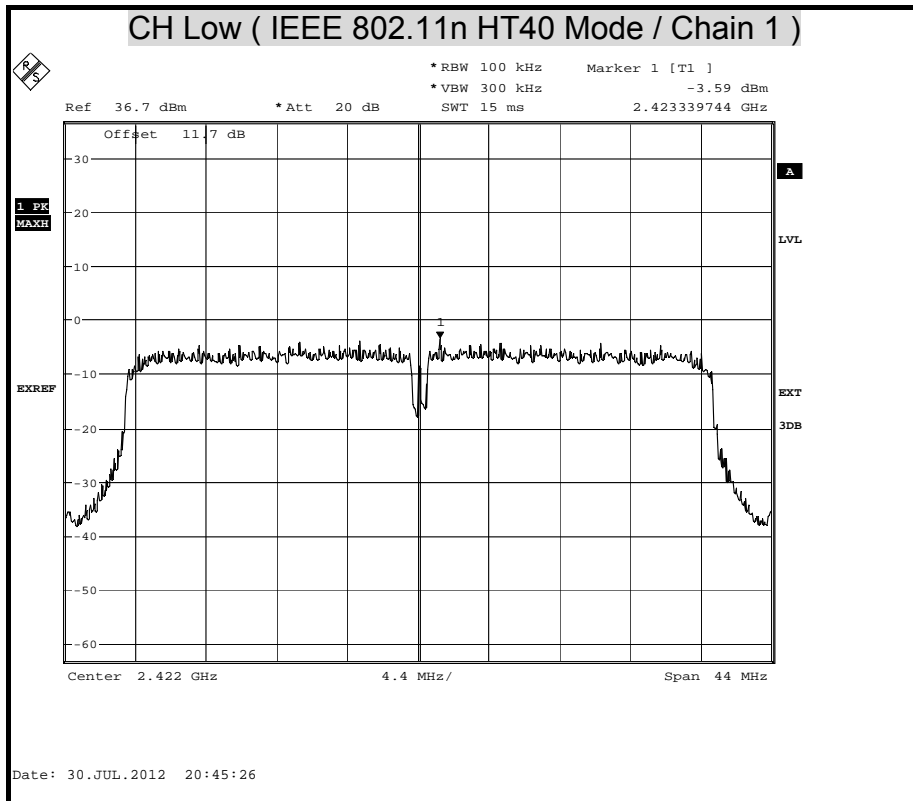

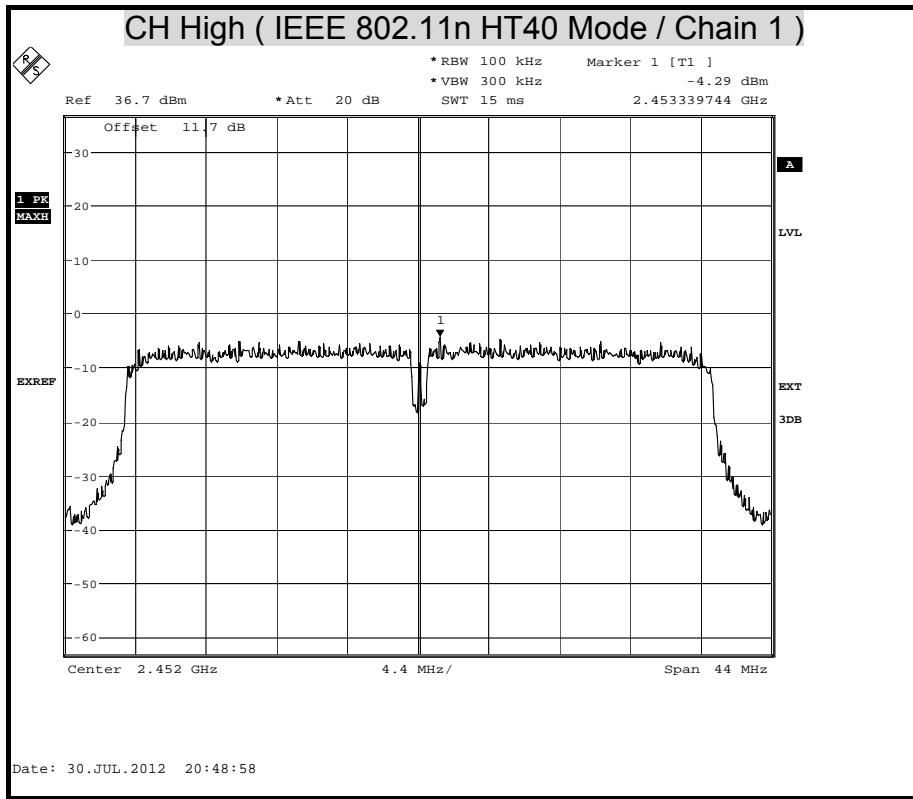



POWER SPECTRAL DENSITY (5G)

