



FCC 47 CFR PART 15 SUBPART C AND ANSI C63.4: 2003

TEST REPORT

For

Wireless N300 Cloud VPN Router

Model: DIR-640LA1

Brand: 

Issued for

D-Link Corporation

No.289 , Sinhu 3rd Rd. , Neihu District , Taipei City 114 , Taiwan R.O.C.

Issued by

Compliance Certification Services Inc.

Tainan Lab.

No.8,Jiucengling, Xinhua Dist., Tainan City 712, Taiwan (R.O.C.)

TEL: 886-6-580-2201

FAX: 886-6-580-2202

Date of Issue: August 24, 2012



Note: This report shall not be reproduced except in full, without the written approval of Compliance Certification Services Inc. Ltd. This document may be altered or revised by Compliance Certification Services Inc. personnel only, and shall be noted in the revision section of the document



REVISION HISTORY

Rev.	Issue Date	Revisions	Effect Page	Revised By
00	August 24, 2012	Initial Issue	ALL	Sunny Chang



TABLE OF CONTENTS

1. TEST REPORT CERTIFICATION4

2. EUT DESCRIPTION5

3. DESCRIPTION OF TEST MODES6

4. TEST METHODOLOGY7

5. FACILITIES AND ACCREDITATIONS.....7

 5.1 FACILITIES7

 5.2 EQUIPMENT7

 5.3 LABORATORY ACCREDITATIONS LISTINGS7

 5.4 TABLE OF ACCREDITATIONS AND LISTINGS8

6. CALIBRATION AND UNCERTAINTY.....8

 6.1 MEASURING INSTRUMENT CALIBRATION8

 6.2 MEASUREMENT UNCERTAINTY8

7. SETUP OF EQUIPMENT UNDER TEST.....9

 7.1 SETUP CONFIGURATION OF EUT.....9

 7.2 SUPPORT EQUIPMENT9

 7.2 SUPPORT EQUIPMENT10

 7.3 EUT OPERATING CONDITION11

8. APPLICABLE LIMITS AND TEST RESULTS..... 12

 8.1 6DB BANDWIDTH12

 8.2 MAXIMUM PEAK OUTPUT POWER.....27

 8.3 MAXIMUM PERMISSIBLE EXPOSURE56

 8.4 POWER SPECTRAL DENSITY58

 8.5 CONDUCTED SPURIOUS EMISSION72

 8.6 RADIATED EMISSIONS91

 8.7 POWERLINE CONDUCTED EMISSIONS.....128

9. ANTENNA REQUIREMENT 134

 9.1 STANDARD APPLICABLE134

 9.2 ANTENNA CONNECTED CONSTRUCTION.....134

APPENDIX SETUP PHOTOS 135

APPENDIX II PHOTOGRAPHS OF EUT.....A1



1. TEST REPORT CERTIFICATION

Applicant : D-Link Corporation

Address : No.289 , Sinhu 3rd Rd. , Neihu District , Taipei City 114 , Taiwan R.O.C.

Manufacturer : Advance Multimedia Internet Technology Inc.

Address : No.28, Lane 31, Sec. 1, Huandong Rd., Sinshih District, Tainan City
74146, Taiwan

Equipment Under Test : Wireless N300 Cloud VPN Router

Model : DIR-640LA1

Brand : 

Date of Test : August 13, 2012 ~ August 16, 2012

APPLICABLE STANDARD	
STANDARD	TEST RESULT
FCC Part 15 Subpart C AND ANSI C63.4 : 2003	No non-compliance noted

Approved by:

Reviewed by:



Jeter Wu
Assistant Manager

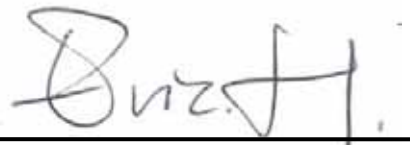

Eric Huang
Assistant Section Manager



2. EUT DESCRIPTION

Product Name	Wireless N300 Cloud VPN Router
Model	DIR-640LA1
Brand	
Received Date	August 10, 2012
Frequency Range	IEEE 802.11b/g, 802.11n HT20 (DTS Band):2412MHz~2462MHz IEEE 802.11n HT40 (DTS Band):2422MHz~2452MHz
Transmit Power	IEEE 802.11b Mode : 23.43dBm (DTS Band) (220.3mW) IEEE 802.11g Mode : 20.81dBm (DTS Band) (120.5mW) IEEE 802.11n HT20 Mode : 22.87dBm (DTS Band) (193.7mW) IEEE 802.11n HT40 Mode : 18.72dBm (DTS Band) (74.39mW)
Channel Spacing	IEEE 802.11b/g, 802.11n HT20/HT40: 5MHz
Channel Number	IEEE 802.11b/g, 802.11n HT20:11 Channels IEEE 802.11n HT40 :7 Channels
Transmit Data Rate	IEEE 802.11 b : 11, 5.5, 2, 1 Mbps IEEE 802.11g : 54, 48, 36, 24, 18, 12, 9, 6 Mbps IEEE 802.11n HT20 : 130, 117, 104, 78, 65, 58.5, 52, 39, 26, 19.5, 13, 6.5 Mbps IEEE 802.11n HT40 : 300, 270, 243, 216, 162, 150, 135, 121.5, 108, 81, 54, 40.5, 27, 13.5 Mbps
Type of Modulation	IEEE 802.11b : DSSS (CCK, DQPSK, DBPSK)
	IEEE 802.11g : OFDM (64QAM, 16QAM, QPSK, BPSK)
	IEEE 802.11n HT20/40 : OFDM (64QAM, 16QAM, QPSK, BPSK)
Frequency Selection	By software / firmware
Antenna Type	Antenna (2Tx2Rx) Type: Omni-directional Model: C381-510193-A Gain: 2.0 dBi
Power Source	Powered from adapter Brand: D-Link Model: AMS9-1201000FU2 I/P: 100-240Vac, 50/60Hz, 0.5A O/P: 12Vdc, 1.0A
Temperature Range	0 ~ +55°C

REMARK:

1. The sample selected for test was engineering sample that approximated to production product and was provided by manufacturer.
2. This submittal(s) (test report) is intended for FCC ID: KA2IR640LA1 filing to comply with Section 15.207, 15.209 and 15.247 of the FCC Part 15, Subpart C Rules.
3. For more details, please refer to the User's manual of the EUT.



3. DESCRIPTION OF TEST MODES

The EUT is a 11n router. It has two transmitter chains and two receive chains (2x2 configurations). The 2x2 configuration is implemented with two outside chains (Chain 0 and Chain 1).

The RF chipset is manufactured by Ralink Technology, Corp.

The antenna peak gain 2dBi (highest gain) were chosen for full testing.

IEEE 802.11 b ,802.11g ,802.11n HT20 mode (DTS Band)

The EUT had been tested under operating condition.

There are three channels have been tested as following:

Channel	Frequency (MHz)
Low	2412
Middle	2437
High	2462

IEEE 802.11b mode: 1Mbps long data rate (worst case) were chosen for full testing.

IEEE 802.11g mode: 6Mbps data rate (worst case) were chosen for full testing.

IEEE 802.11n HT20 mode: 13Mbps data rate (worst case) were chosen for full testing.

IEEE 802.11n HT40 mode (DTS Band)

The EUT had been tested under operating condition.

There are three channels have been tested as following:

Channel	Frequency (MHz)
Low	2422
Middle	2437
High	2452

IEEE 802.11n HT40 mode: 27Mbps data rate (worst case) were chosen for full testing.

The worst-case data rates are determined according to the description above, based on the investigations by measuring the PSD, peak power and average power across all the data rates, bandwidths, modulations and spatial stream modes.

The worst-case channel is determined as the channel with the highest output power. The highest measured output power was at 2452 MHz.



4. TEST METHODOLOGY

The tests documented in this report were performed in accordance with ANSI C63.4 and FCC CFR 47 2.1046, 2046, 2.1047, 2.1049, 2.1051, 2.1053, 2.1055, 2.1057, 15.207, 15.209 and 15.247 and KDB 558074..

5. FACILITIES AND ACCREDITATIONS

5.1 FACILITIES

All measurement facilities used to collect the measurement data are located at No.8, Jiucengling, Xinhua Dist., Tainan City 712, Taiwan (R.O.C.)

The sites are constructed in conformance with the requirements of ANSI C63.7, ANSI C63.4 and CISPR Publication 22.

5.2 EQUIPMENT

Radiated emissions are measured with one or more of the following types of linearly polarized antennas: tuned dipole, bi-conical, log periodic, bi-log, and/or ridged waveguide, horn. Spectrum analyzers with pre-selectors and quasi-peak detectors are used to perform radiated measurements.

Conducted emissions are measured with Line Impedance Stabilization Networks and EMI Test Receivers.

Calibrated wideband preamplifiers, coaxial cables, and coaxial attenuators are also used for making measurements.

All receiving equipment conforms to CISPR Publication 16-1, "Radio Interference Measuring Apparatus and Measurement Methods."

5.3 LABORATORY ACCREDITATIONS LISTINGS

The test facilities used to perform radiated and conducted emissions tests are accredited by Taiwan Accreditation Foundation for the specific scope of accreditation under Lab Code: 1109 to perform Electromagnetic Interference tests according to FCC PART 15 AND CISPR 22 requirements. No part of this report may be used to claim or imply product endorsement by TAF or any agency of the Government. In addition, the test facilities are listed with Federal Communications Commission (registration no: TW-1037).



5.4 TABLE OF ACCREDITATIONS AND LISTINGS

Our laboratories are accredited and approved by the following accreditation body according to ISO/IEC 17025.

Taiwan	TAF
---------------	-----

The measuring facility of laboratories has been authorized or registered by the following approval agencies.

Canada	Industry Canada
Germany	TUV NORD
Taiwan	BSMI
USA	FCC

Copies of granted accreditation certificates are available for downloading from our web site, <http://www.ccsrf.com>

6. CALIBRATION AND UNCERTAINTY

6.1 MEASURING INSTRUMENT CALIBRATION

The measuring equipment utilized to perform the tests documented in this report has been calibrated in accordance with the manufacturer’s recommendations, and is traceable to recognized national standards.

6.2 MEASUREMENT UNCERTAINTY

Where relevant, the following measurement uncertainty levels have been estimated for tests performed on the apparatus:

PARAMETER	UNCERTAINTY
Radiated Emission, 30 to 200 MHz Test Site : OATS-6	±3.59dB
Radiated Emission, 200 to 1000 MHz Test Site : OATS-6	±3.27dB
Radiated Emission, 1 to 26.5 GHz	± 3.20dB
Power Line Conducted Emission	± 2.90dB

Uncertainty figures are valid to a confidence level of 95%, K=2



7. SETUP OF EQUIPMENT UNDER TEST

7.1 SETUP CONFIGURATION OF EUT

For RF test

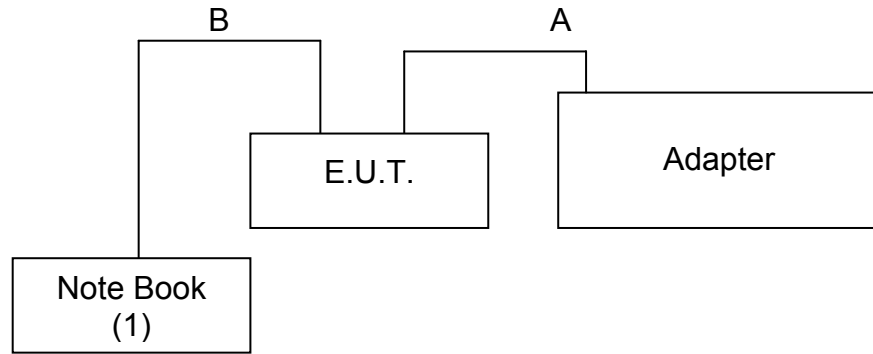

For EMI test

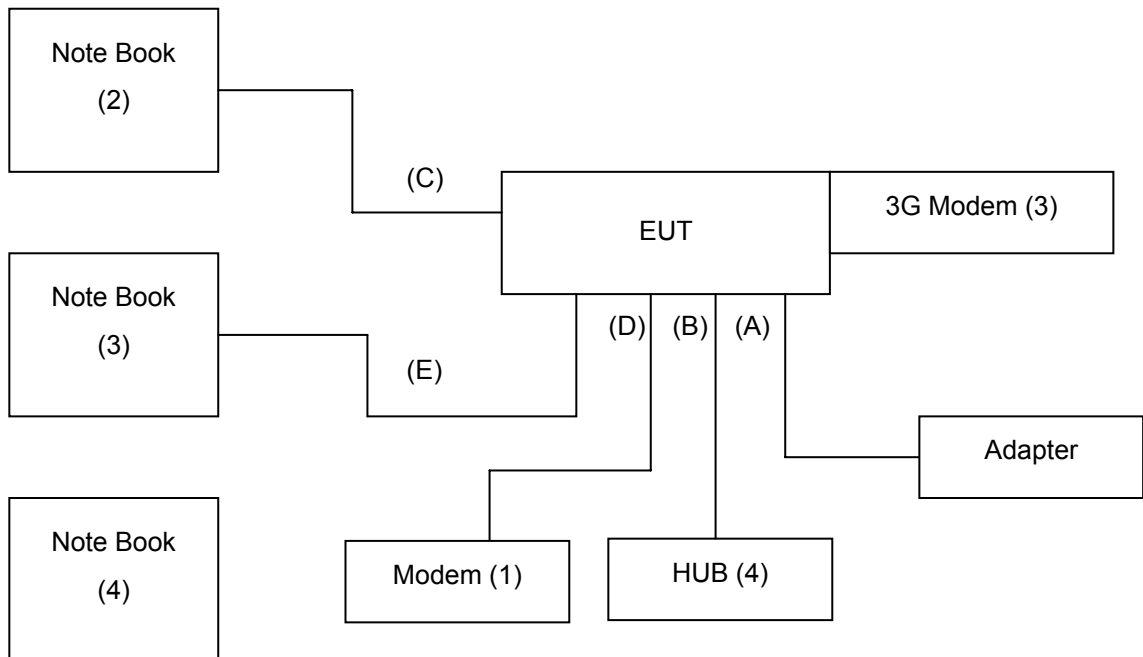



7.2 SUPPORT EQUIPMENT

RF test

No.	Product	Manufacturer	Model No.	Certify No.	Signal cable
1.	Note Book	IBM	T43	DoC	Power cable, unshd, 1.6m

No.	Signal cable description	
A	DC	Unshielded, 1.5m, 1pcs.
B	LAN	Unshielded, 10m, 1pcs.

EMI test

No.	Product	Manufacturer	Model No.	Certify No.	Signal cable
1.	Modem	LEMEL	MD-56K	3882B582	RS232 cable, shd, 1.1m
2.	Note Book	IBM	T43	DoC	Power cable, unshd, 1.6m
3.	Note Book	IBM	R50E	DoC	Power cable, unshd, 1.6m
4.	Note Book	Acer	AS 3830TG	DoC	Power cable, unshd, 1.6m
5.	3G Modem	NOBATEL	Qualcomm 3G CDMA	PKRNVW MC727	N/A
6.	HUB	BARRICAD	SMC7008BR	DoC	Power cable, unshd, 1.6m

No.	Signal cable description	
A	Power	Unshielded, 1.2m, 1pcs.
B	LAN	Unshielded, 2.0m, 3pcs.
C	LAN	Unshielded, 10m, 1pcs.
D	RS232	Shielded, 1.1m, 1pcs.
E	LAN	Unshielded, 10m, 1pcs.

REMARK:

1. All the above equipment/cables were placed in worse case positions to maximize emission signals during emission test.
2. Grounding was established in accordance with the manufacturer's requirements and conditions for the intended use.



7.3 EUT OPERATING CONDITION

RF Setup

1. Set up all computers like the setup diagram.
2. The “Ralink QA Test Program for “RT5x9xQA V1.0.6.6” software was used for testing
The EUT driver software installed in the host support equipment during testing was Ralink QA Test Program for “RT5x9xQA V1.0.6.6” Drive

TX Mode:

- ⇒ **Tx Mode:**CCK 、 OFDM、 HT MixMode (Bandwidth: 20、 40)
- ⇒ **Tx Data Rate:** 1Mbps long (IEEE 802.11b mode , TX)
6Mbps (IEEE 802.11g mode , TX)
13Mbps (IEEE 802.11n HT20 mode ,chain 0, chain 1 TX)
27Mbps (IEEE 802.11n HT40 mode, chain 0, chain 1 TX)

Power control mode

- Target Power:** IEEE 802.11b Channel Low (2412MHz) =1B
IEEE 802.11b Channel Middle (2437MHz) =1C
IEEE 802.11b Channel High (2462MHz) = 1D
- Target Power:** IEEE 802.11g Channel Low (2412MHz) = 0A
IEEE 802.11g Channel Middle (2437MHz) = 0B
IEEE 802.11g Channel High (2462MHz) = 0C
- Target Power:** IEEE 802.11n HT20 Channel Low (2412MHz) = 09 (**Chain 0**)
IEEE 802.11 n HT20 Channel Middle (2437MHz) =0A (**Chain 0**)
IEEE 802.11 n HT20 Channel High (2462MHz) = 0B (**Chain 0**)
IEEE 802.11n HT20 Channel Low (2412MHz) = 0B (**Chain 1**)
IEEE 802.11 n HT20 Channel Middle (2437MHz) = 0D (**Chain 1**)
IEEE 802.11 n HT20 Channel High (2462MHz) = 0E (**Chain 1**)
- Target Power:** IEEE 802.11n HT40 Channel Low (2422MHz) = 00 (**Chain 0**)
IEEE 802.11 n HT40 Channel Middle (2437MHz) = 02 (**Chain 0**)
IEEE 802.11 n HT40 Channel High (2452MHz) = 03 (**Chain 0**)
IEEE 802.11n HT40 Channel Low (2422MHz) = 02 (**Chain 1**)
IEEE 802.11 n HT40 Channel Middle (2437MHz) = 05(**Chain 1**)
IEEE 802.11 n HT40 Channel High (2452MHz) = 10 (**Chain 1**)

RX Mode :

Start RX

3. All of the function are under run.
4. Start test.

Normal Link Setup

1. Set up all computers like the setup diagram.
 2. All of the function are under run.
 3. Notebook PC (2) ping 192.168.0.10 –t to Notebook PC (1).
 4. Notebook PC (1) ping 192.168.0.20 –t to Notebook PC (2).
 5. Notebook PC (1) ping 192.168.0.50 –t to Wireless Access Point (3).
- Start test.



8. APPLICABLE LIMITS AND TEST RESULTS

8.1 6DB BANDWIDTH

LIMIT

§ 15.247(a) (2) For direct sequence systems, the minimum 6dB bandwidth shall be at least 500kHz

TEST EQUIPMENTS

Name of Equipment	Manufacturer	Model	Serial Number	Calibration Due
Spectrum Analyzer	R&S	FSU	200789	SEP. 29, 2012

TEST SETUP

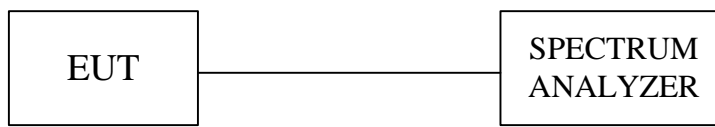

TEST PROCEDURE

The transmitter output was connected to a spectrum analyzer. The bandwidth of the fundamental frequency was measured by spectrum analyzer with 100 KHz RBW and 100 KHz VBW. The 6dB bandwidth is defined as the total spectrum the power of which is higher than peak power minus 6dB.



TEST RESULTS

No non-compliance noted.

IEEE 802.11b mode

Channel	Channel Frequency (MHz)	6dB Bandwidth (MHz)	Minimum Limit (kHz)	Pass / Fail
Low	2412	12.12	500	PASS
Middle	2437	12.12	500	PASS
High	2462	12.12	500	PASS

NOTE :

1. At final test to get the worst-case emission at 1Mbps long.
2. The cable assembly insertion loss of 11.7dB (including 10 dB pad and 1.7 dB cable) was entered as an offset in the spectrum analyzer to allow for direct reading of power.

IEEE 802.11g mode

Channel	Channel Frequency (MHz)	6dB Bandwidth (MHz)	Minimum Limit (kHz)	Pass / Fail
Low	2412	16.47	500	PASS
Middle	2437	16.47	500	PASS
High	2462	16.47	500	PASS

NOTE :

1. At final test to get the worst-case emission at 6Mbps.
2. The cable assembly insertion loss of 11.7dB (including 10 dB pad and 1.7 dB cable) was entered as an offset in the spectrum analyzer to allow for direct reading of power.



IEEE 802.11n HT20 mode

Channel	Channel Frequency (MHz)	6dB Bandwidth (MHz)		Minimum Limit (kHz)	Pass / Fail
		Chain 0	Chain1		
Low	2412	17.63	17.69	500	PASS
Middle	2437	17.56	17.69	500	PASS
High	2462	17.56	17.69	500	PASS

NOTE :

1. At final test to get the worst-case emission at 13Mbps.
2. The cable assembly insertion loss of 11.7dB (including 10 dB pad and 1.7 dB cable) was entered as an offset in the spectrum analyzer to allow for direct reading of power.

IEEE 802.11n HT40 mode

Channel	Channel Frequency (MHz)	6dB Bandwidth (MHz)		Minimum Limit (kHz)	Pass / Fail
		Chain 0	Chain1		
Low	2422	36.15	36.28	500	PASS
Middle	2437	36.15	36.15	500	PASS
High	2452	36.15	36.15	500	PASS

NOTE :

1. At final test to get the worst-case emission at 27Mbps.
2. The cable assembly insertion loss of 11.7dB (including 10 dB pad and 1.7 dB cable) was entered as an offset in the spectrum analyzer to allow for direct reading of power.



6dB BANDWIDTH (802.11b MODE)

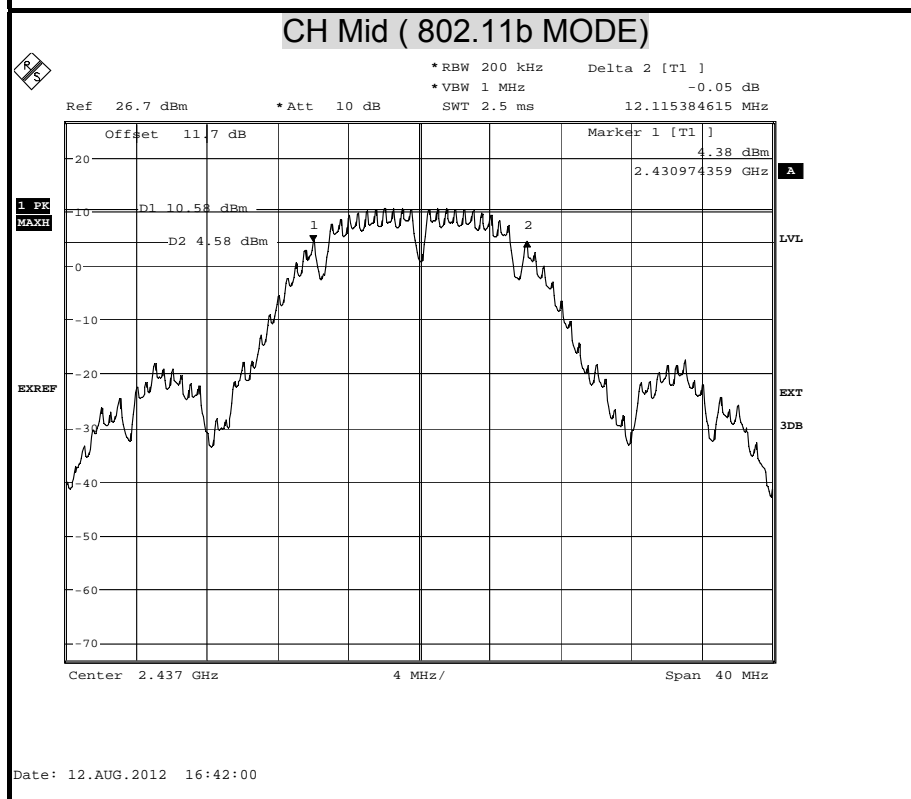
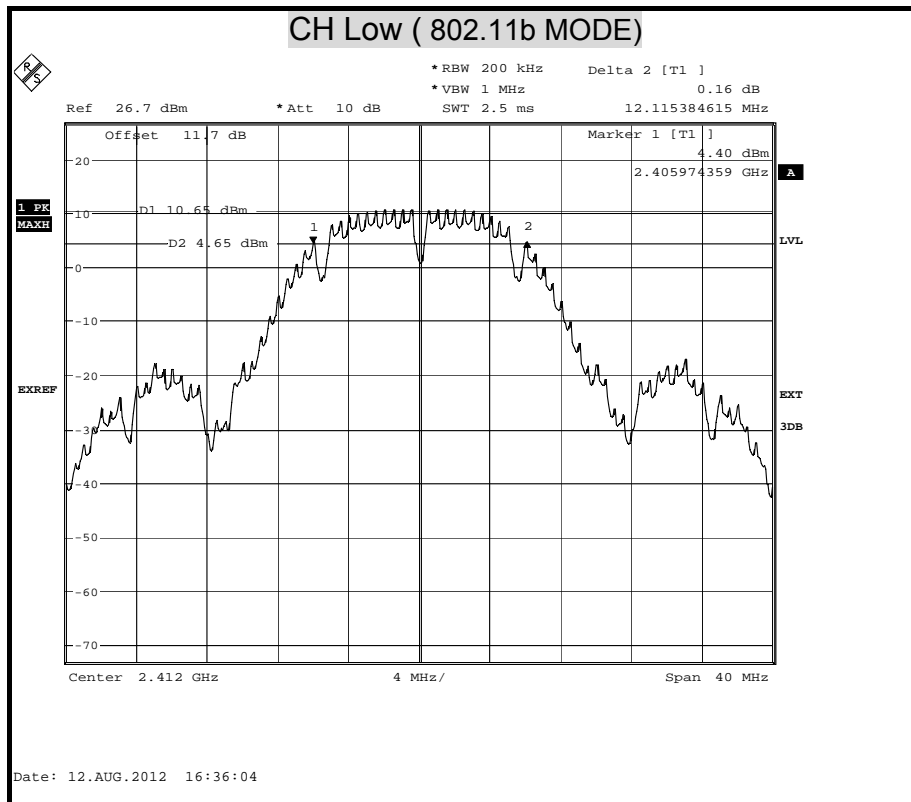



6dB BANDWIDTH (802.11g MODE)

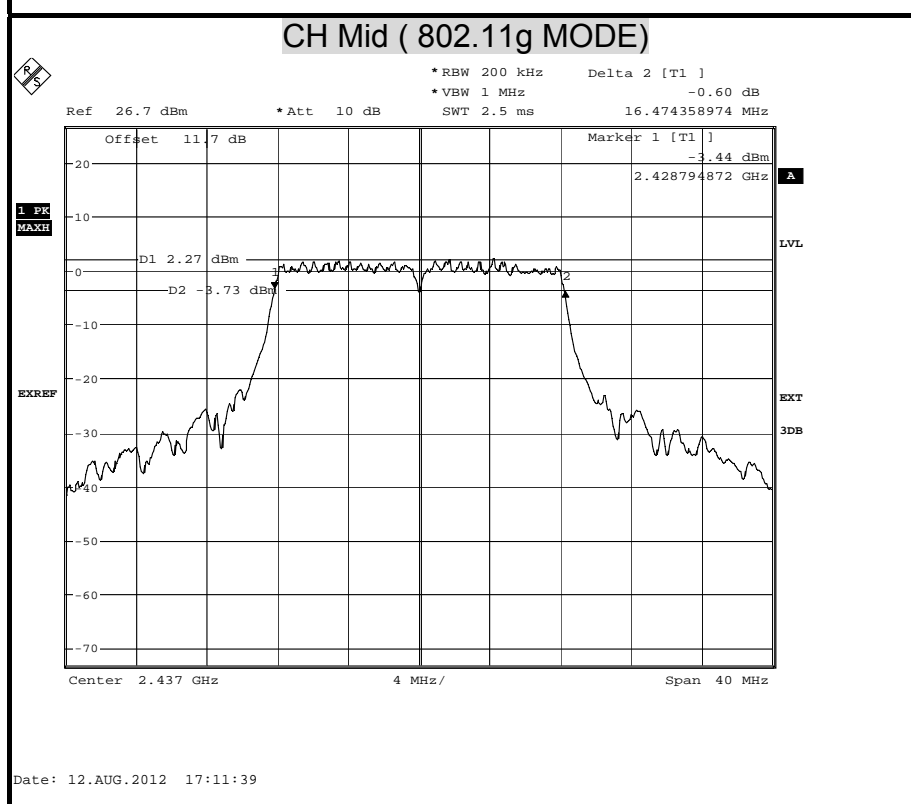
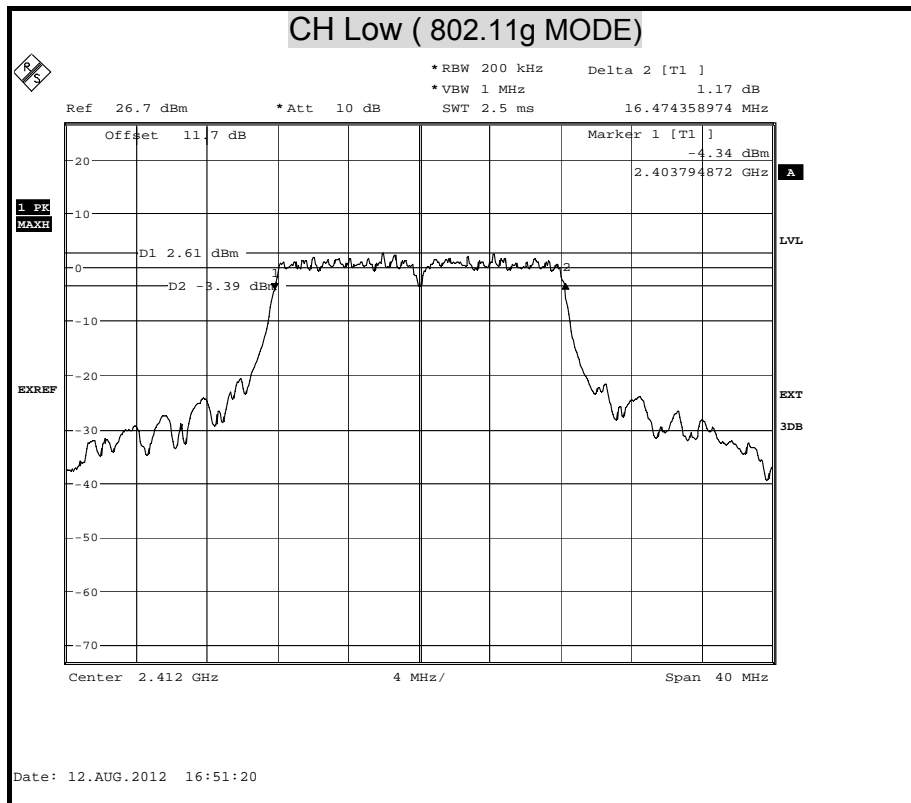

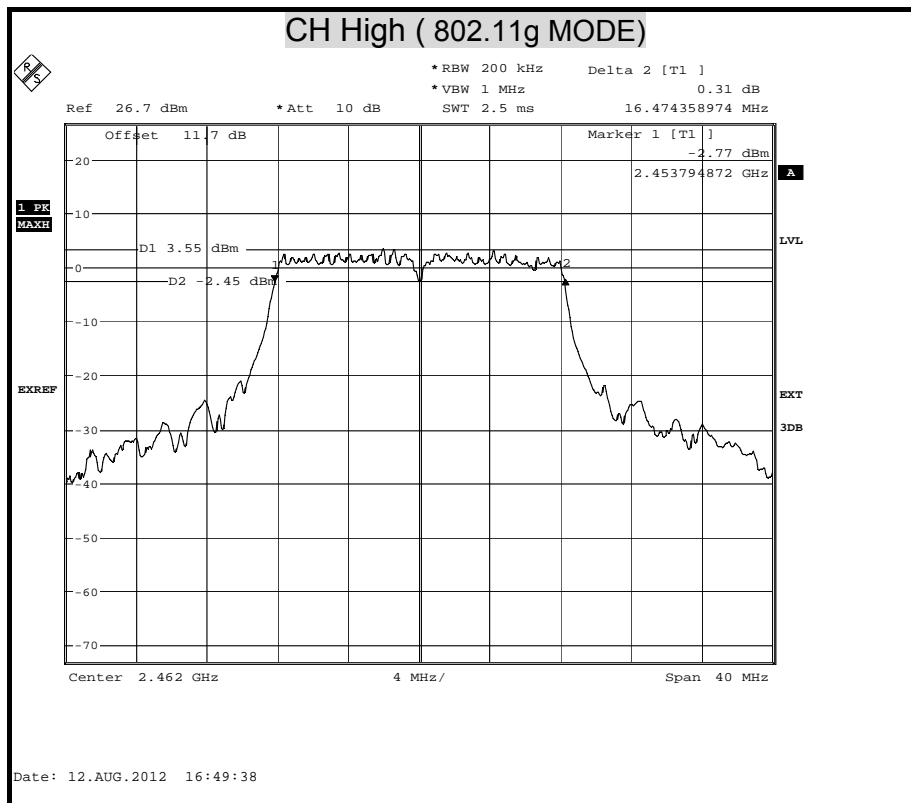



6dB BANDWIDTH (802.11n HT20 MODE) Chain 0

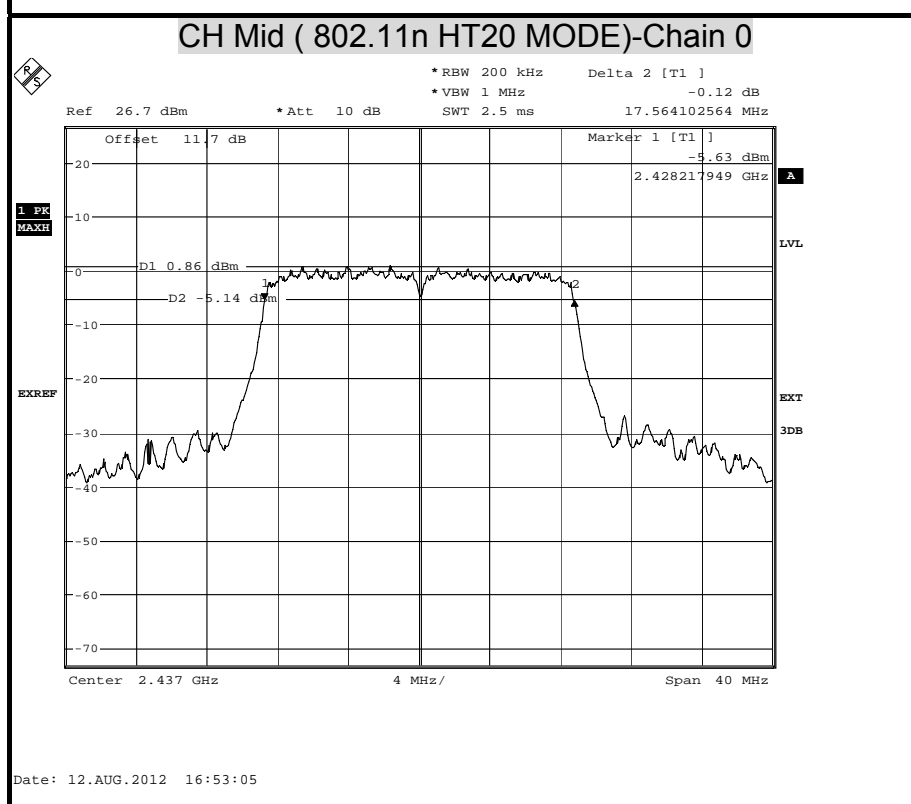
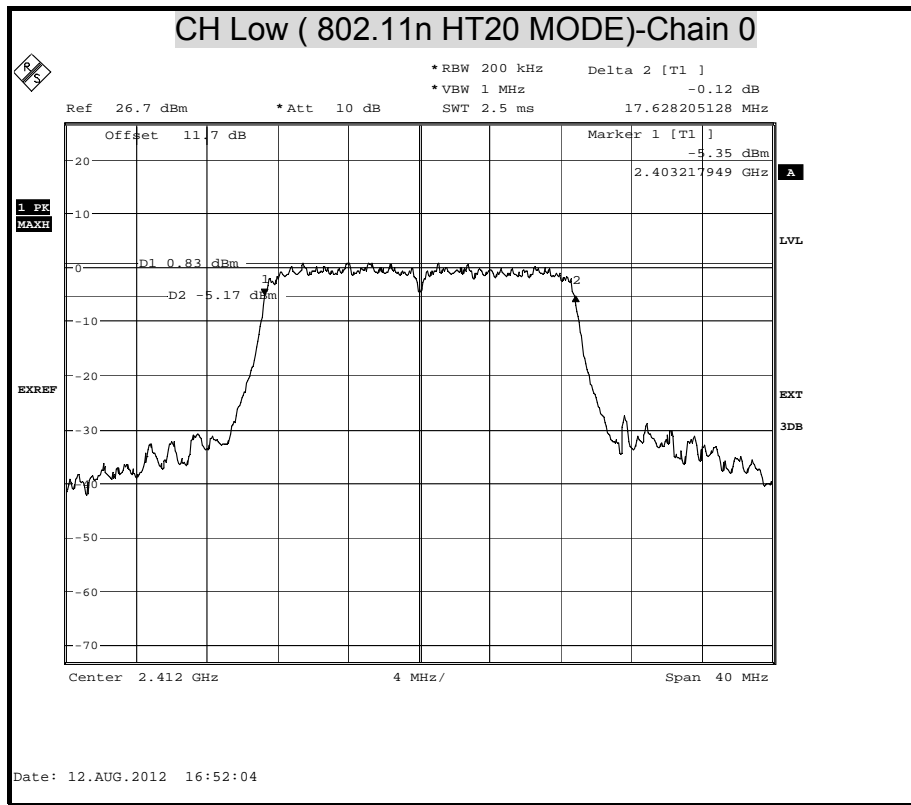

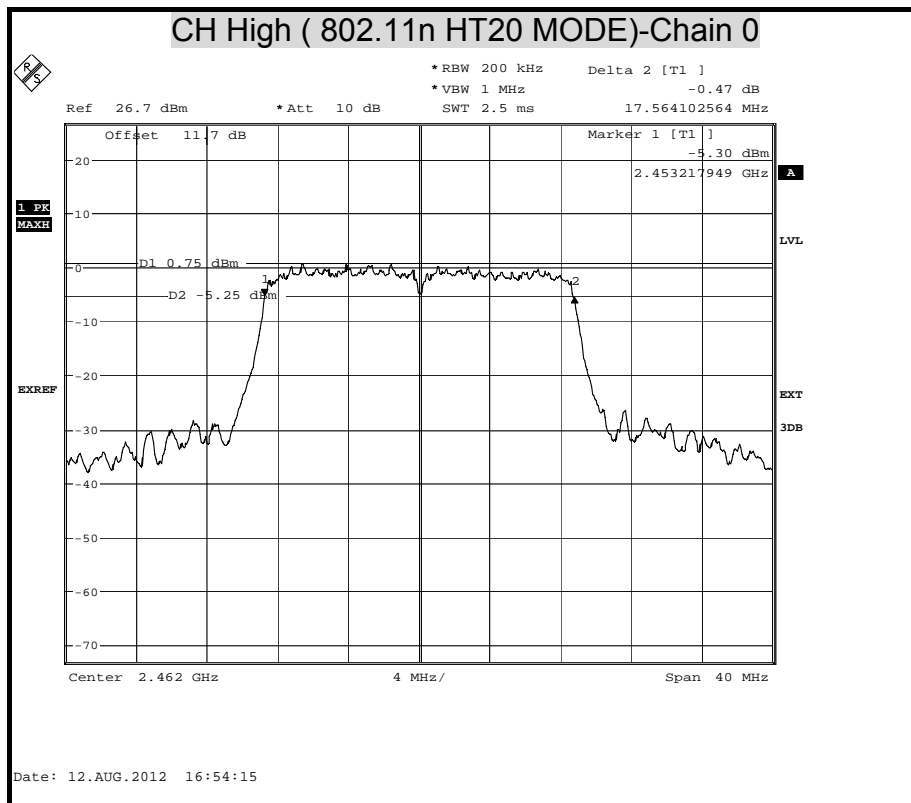



6dB BANDWIDTH (802.11n HT20 MODE) Chain 1

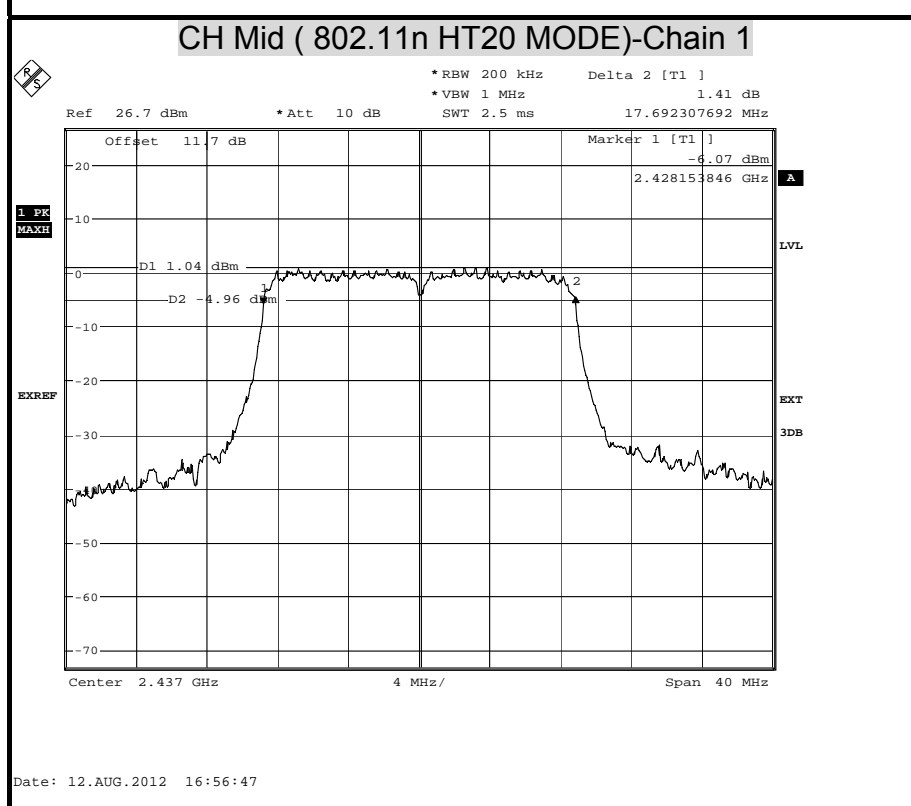
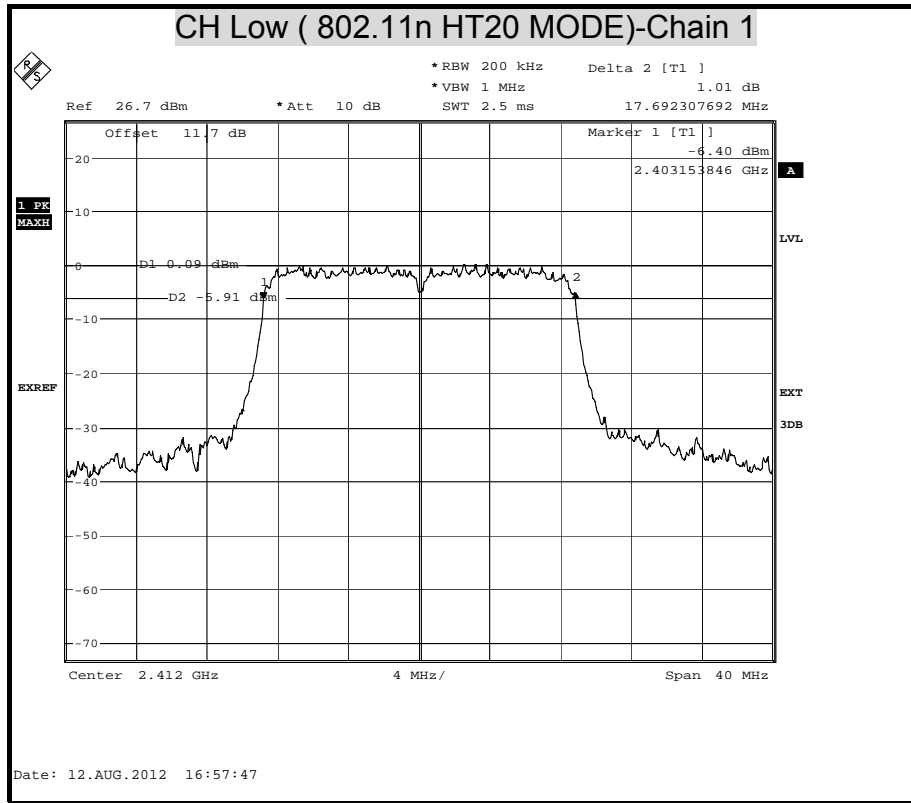



6dB BANDWIDTH (802.11n HT40 MODE) Chain 0

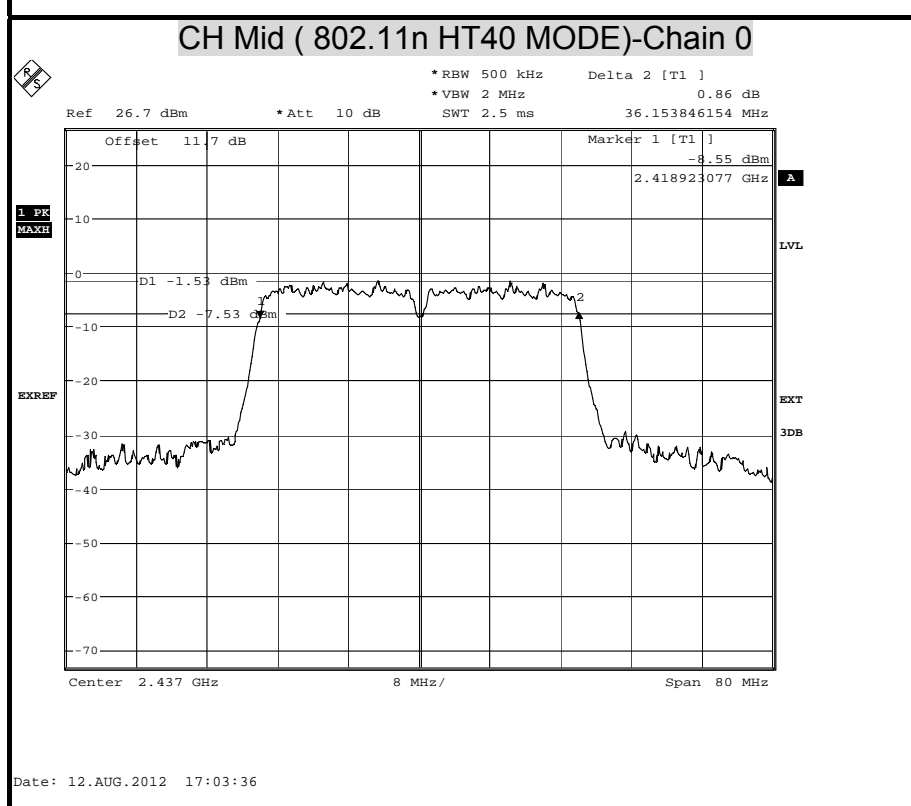
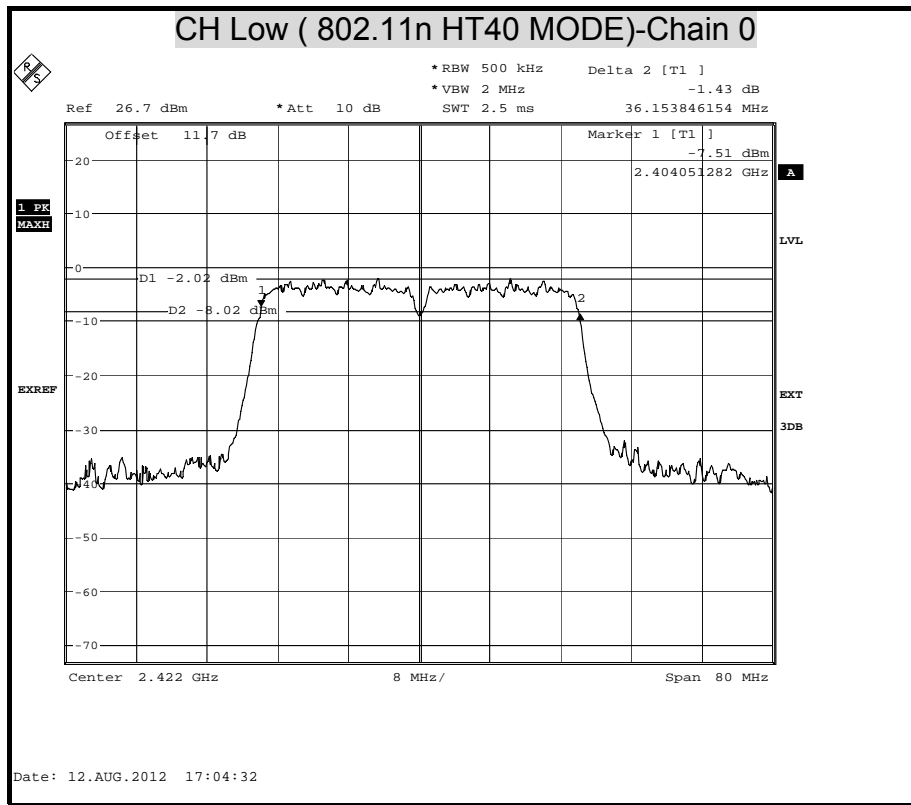



6dB BANDWIDTH (802.11n HT40 MODE) Chain 1

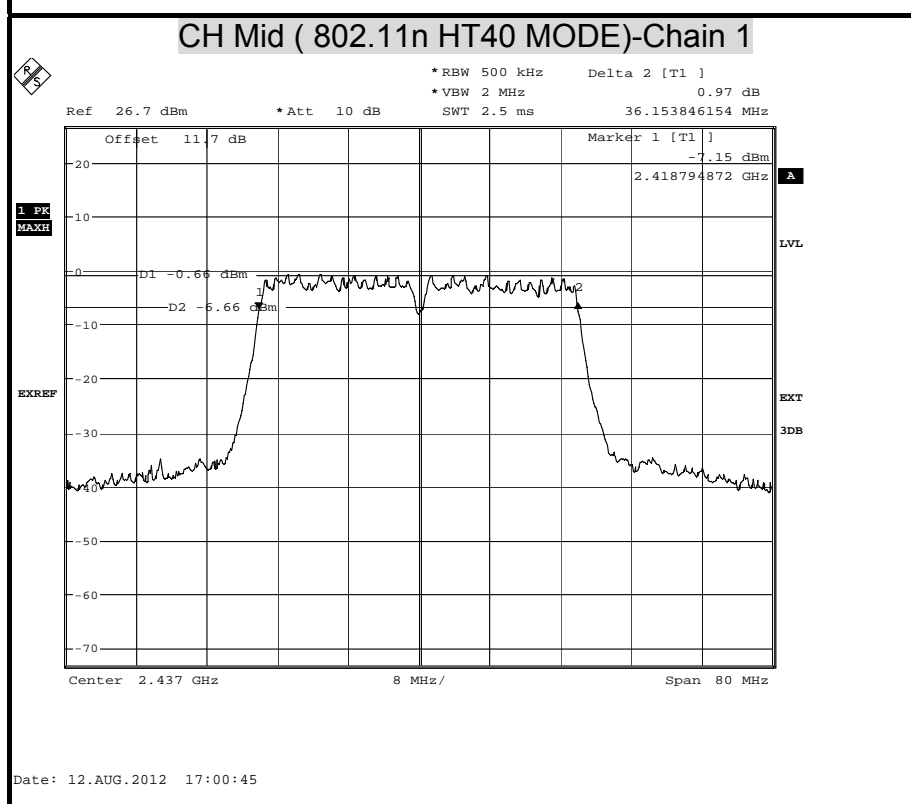
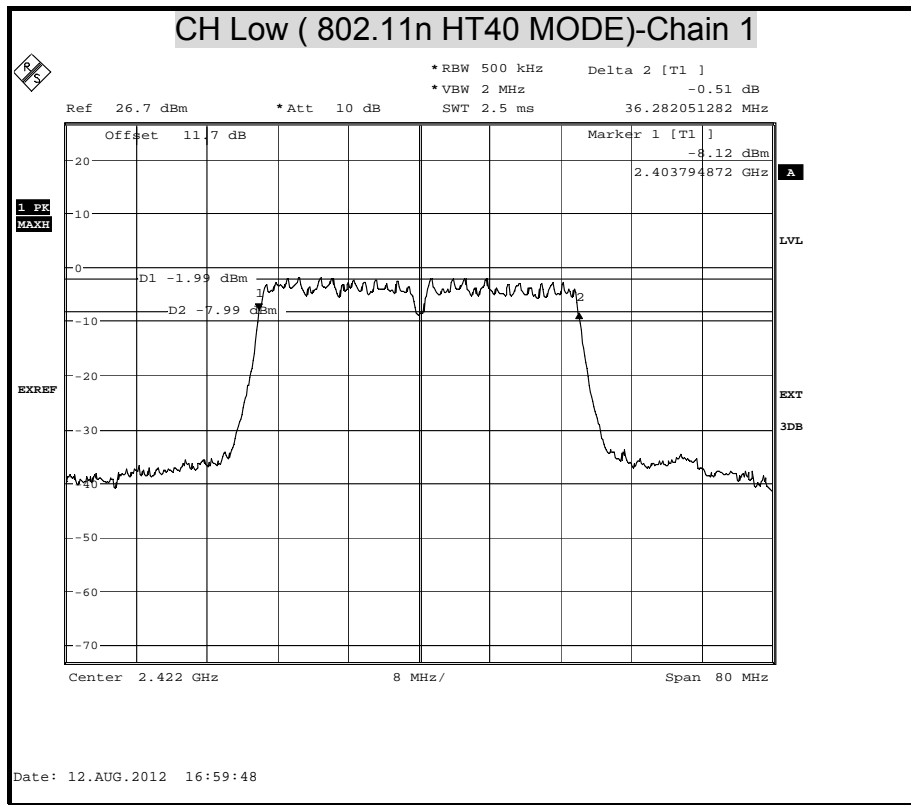

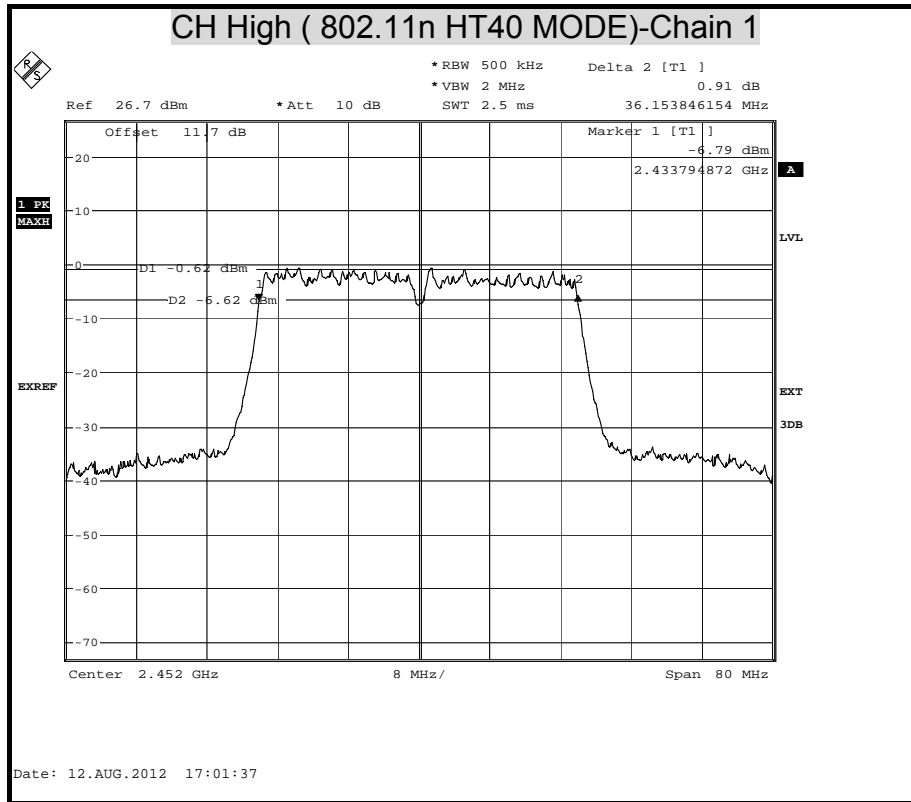



8.2 MAXIMUM PEAK OUTPUT POWER

LIMIT

§ 15.247(b) The maximum peak output power of the intentional radiator shall not exceed the following :

§ 15.247(b) (3) For systems using digital modulation in the 902-928 MHz, 2400-2483.5 MHz, and 5725-5850 MHz bands : 1 watt.

§ 15.247(b) (4) Except as shown in paragraphs (c) of this section , if transmitting antennas of directional gain greater than 6 dBi are used the peak output power from the intentional radiator shall be reduced below the stated values in paragraphs (b)(1) or (b)(2), and (b)(3) of this section , as appropriate, by the amount in dB that the directional gain of the antenna exceeds 6 dBi.

TEST EQUIPMENTS

Name of Equipment	Manufacturer	Model	Serial Number	Calibration Due
Spectrum Analyzer	R&S	FSU	200789	SEP. 29, 2012

TEST SETUP

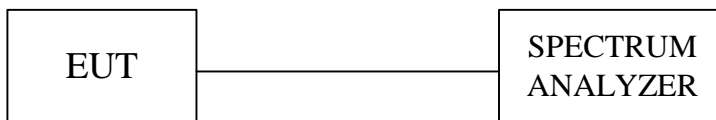



TEST PROCEDURE

The tests were performed in accordance with KDB 558074 5.2.1.2 and 5.2.2.1.

5.2.1.2 Measurement Procedure PK2:

- 1.This procedure provides an integrated measurement alternative when the maximum available RBW < EBW.
- 2.Set the RBW = 1 MHz.
- 3.Set the VBW = 3 MHz.
- 4.Set the span to a value that is 5-30 % greater than the EBW.
- 5.Detector = peak.
- 6.Sweep time = auto couple.
- 7.Trace mode = max hold.
- 8.Allow trace to fully stabilize.
- 9.Use the spectrum analyzer's integrated band power measurement function with band limits set equal to the EBW band edges(for some analyzers, this may require a manual override to ensure use of peak detector). If the spectrum analyzer does not have a band power function, sum the spectrum levels (in linear power units) at 1 MHz intervals extending across the EBW of the spectrum.

5.2.2.1 Measurement Procedure AVG1(power averaging over the EBW with slow sweep speed):

- 1.Set the analyzer span to 5-30% greater than the EBW.
- 2.Set the RBW = 1 MHz.
- 3.Set the VBW \geq 3 MHz.
- 4.Detector = power average (RMS).
- 5.Ensure that the number of measurement points in the sweep \geq 2 x (span/RBW).
- 6.Manually set the sweep time to: \geq 10 x (number of measurement points in sweep) x (transmission symbol period).
- 7.Perform the measurement over a single sweep.
- 8.Use the spectrum analyzer's integrated band power measurement function with band limits set equal to the EBW band edges to determine the maximum conducted output power of the EUT over the EBW. Note: If the analyzer does not have a band power function, sum the spectral levels (in linear power units) at 1 MHz intervals extending across the entire EBW.

TEST RESULTS

No non-compliance noted



IEEE 802.11b mode

Channel	Channel Frequency (MHz)	Peak Power (dBm)	Peak Power Limit (dBm)	Pass / Fail
Low	2412	23.33	30.00	PASS
Middle	2437	23.43	30.00	PASS
High	2462	23.15	30.00	PASS

NOTE : 1. At final test to get the worst-case emission at 1Mbps long.
2. The cable assembly insertion loss of 11.7dB (including 10 dB pad and 1.7 dB cable) was entered as an offset in the spectrum analyzer to allow for direct reading of power.

IEEE 802.11g mode

Channel	Channel Frequency (MHz)	Peak Power (dBm)	Peak Power Limit (dBm)	Pass / Fail
Low	2412	20.55	30.00	PASS
Middle	2437	20.49	30.00	PASS
High	2462	20.81	30.00	PASS

NOTE : 1. At final test to get the worst-case emission at 6Mbps.
2. The cable assembly insertion loss of 11.7dB (including 10 dB pad and 1.7 dB cable) was entered as an offset in the spectrum analyzer to allow for direct reading of power.



IEEE 802.11n HT20 mode

Channel	Channel Frequency (MHz)	Peak Power (dBm)		Peak Power Total (dBm)	Peak Power Limit (dBm)	Pass / Fail
		Chain 0	Chain 1			
Low	2412	19.41	19.28	22.36	30.00	PASS
Middle	2437	19.32	20.34	22.87	30.00	PASS
High	2462	19.26	19.60	22.44	30.00	PASS

NOTE : 1. At final test to get the worst-case emission at 13Mbps.
2. The cable assembly insertion loss of 11.7dB (including 10 dB pad and 1.7 dB cable) was entered as an offset in the spectrum analyzer to allow for direct reading of power.

IEEE 802.11n HT40 mode

Channel	Channel Frequency (MHz)	Peak Power (dBm)		Peak Power Total (dBm)	Peak Power Limit (dBm)	Pass / Fail
		Chain 0	Chain 1			
Low	2422	14.80	14.79	17.81	30.00	PASS
Middle	2437	15.49	15.91	18.72	30.00	PASS
High	2452	15.28	16.00	18.67	30.00	PASS

NOTE : 1. At final test to get the worst-case emission at 27Mbps.
2. The cable assembly insertion loss of 11.7dB (including 10 dB pad and 1.7 dB cable) was entered as an offset in the spectrum analyzer to allow for direct reading of power.



Average Power Data

IEEE 802.11b mode

Channel	Channel Frequency (MHz)	Average Power (dBm)
Low	2412	20.66
Middle	2437	20.69
High	2462	20.45

IEEE 802.11g mode

Channel	Channel Frequency (MHz)	Average Power (dBm)
Low	2412	14.66
Middle	2437	14.57
High	2462	15.02

IEEE 802.11n HT20 mode

Channel	Channel Frequency (MHz)	Average Power (dBm)	Average Power (dBm)
		Chain 0	Chain 1
Low	2412	13.30	13.63
Middle	2437	13.35	14.24
High	2462	12.90	13.86

IEEE 802.11n HT40 mode

Channel	Channel Frequency (MHz)	Average Power (dBm)	Average Power (dBm)
		Chain 0	Chain 1
Low	2422	8.82	8.85
Middle	2437	9.21	10.22
High	2452	9.25	9.89



MAXIMUM PEAK OUTPUT POWER (802.11b MODE)

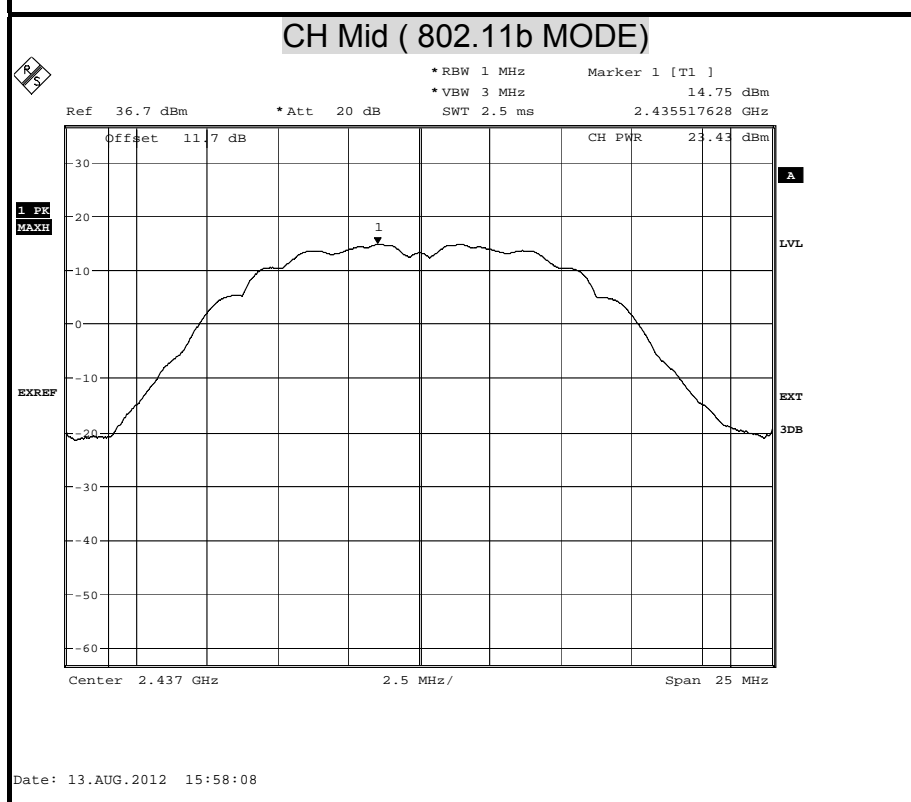
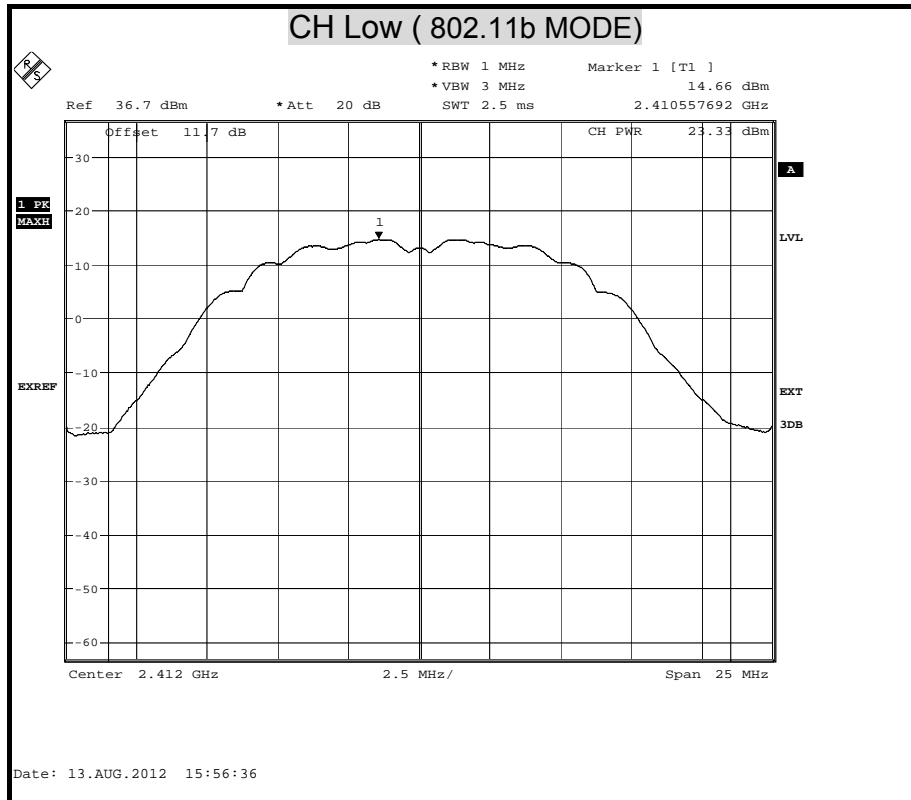



MAXIMUM PEAK OUTPUT POWER (802.11g MODE)

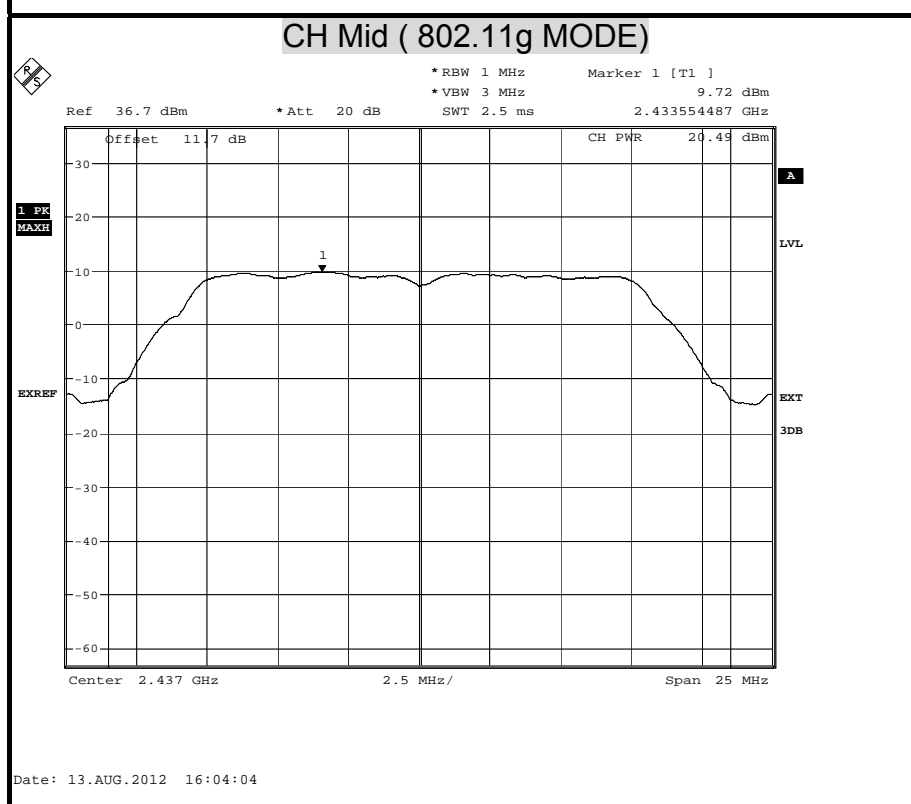
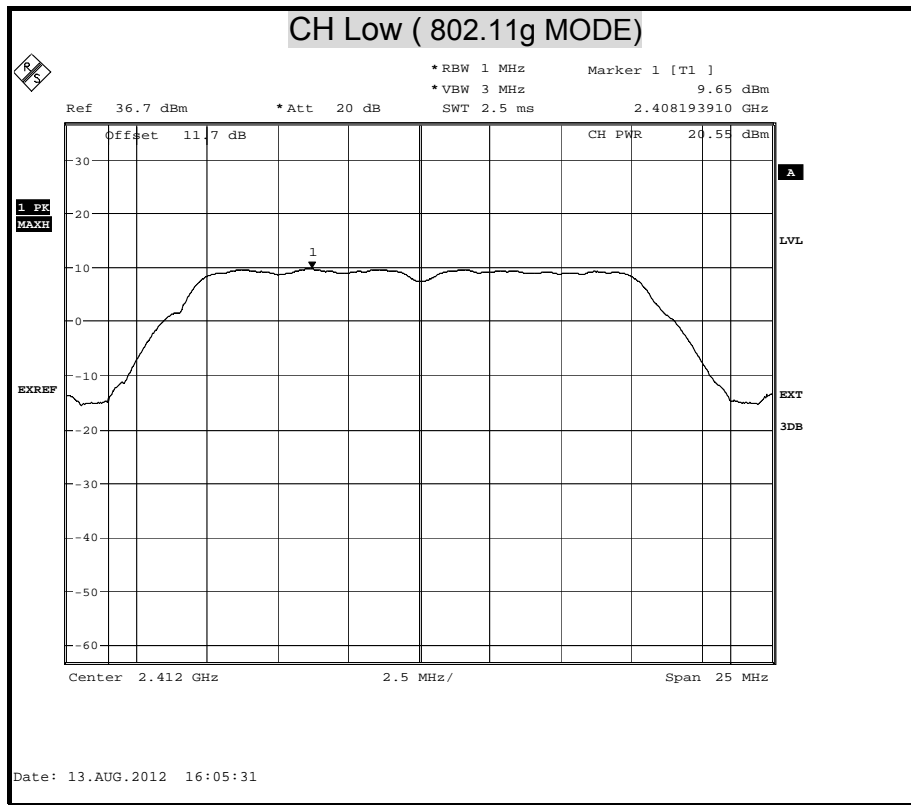

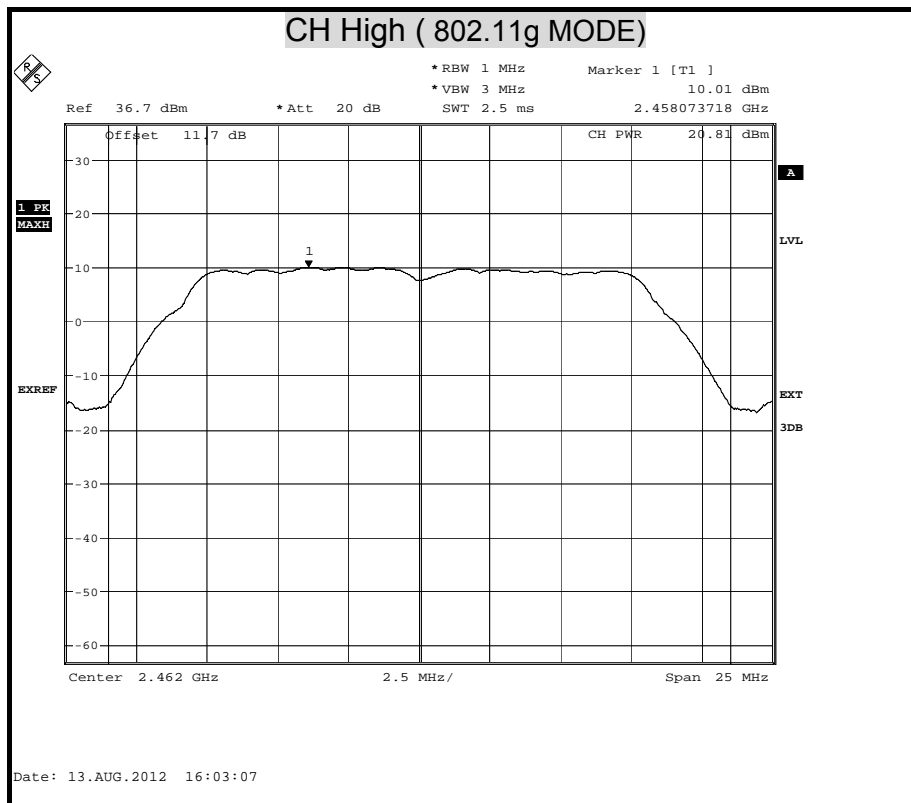



MAXIMUM PEAK OUTPUT POWER (802.11n HT20 MODE) Chain 0

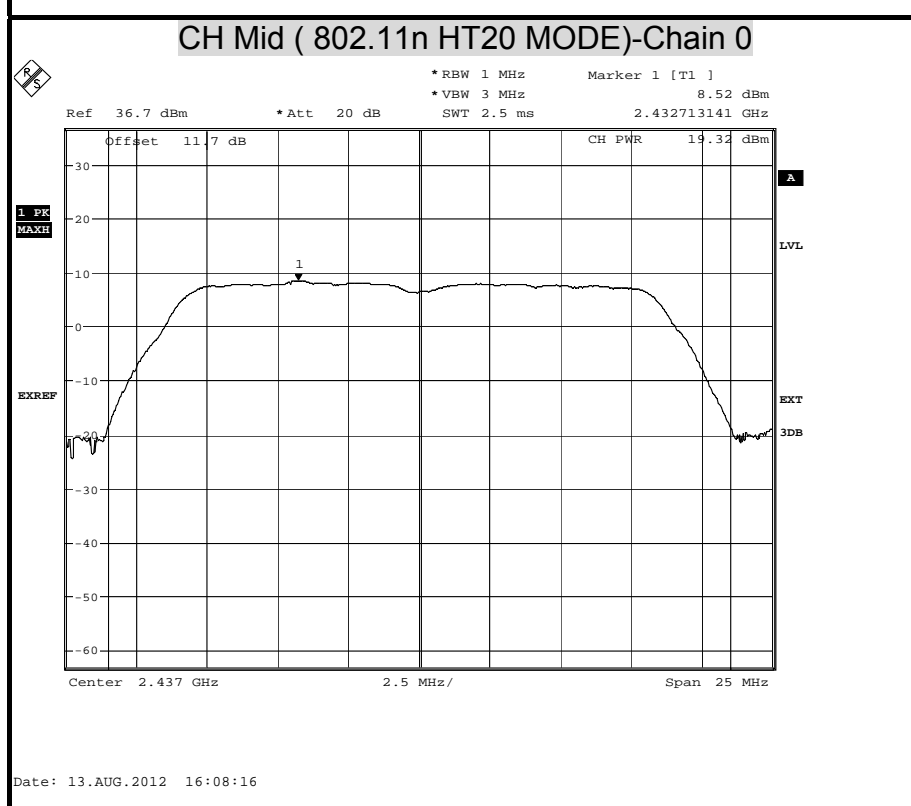
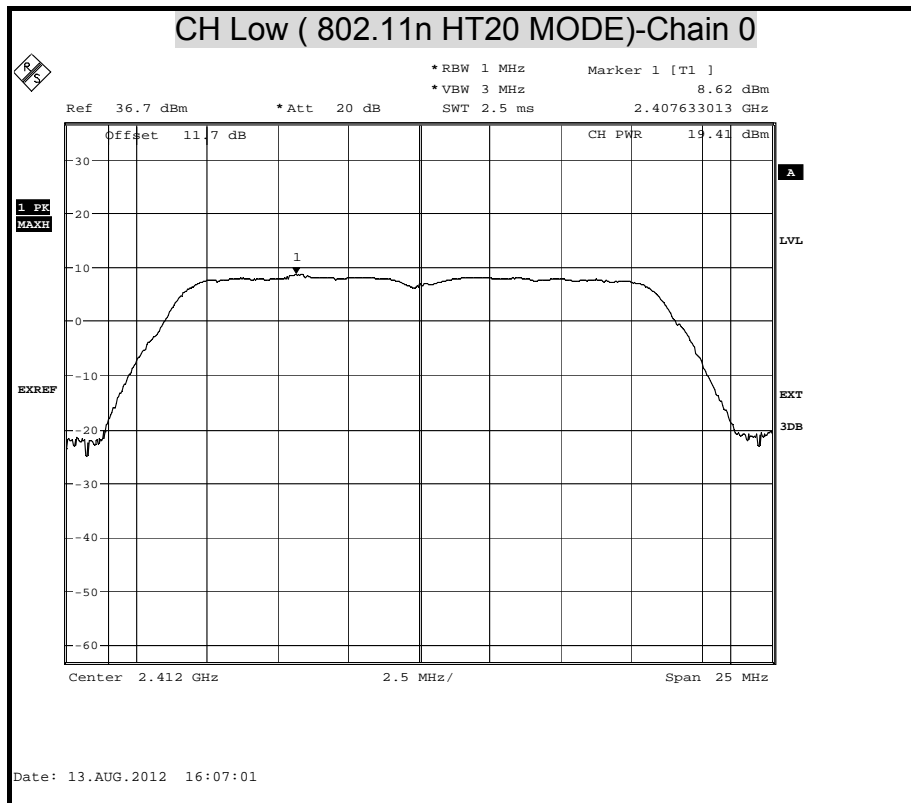

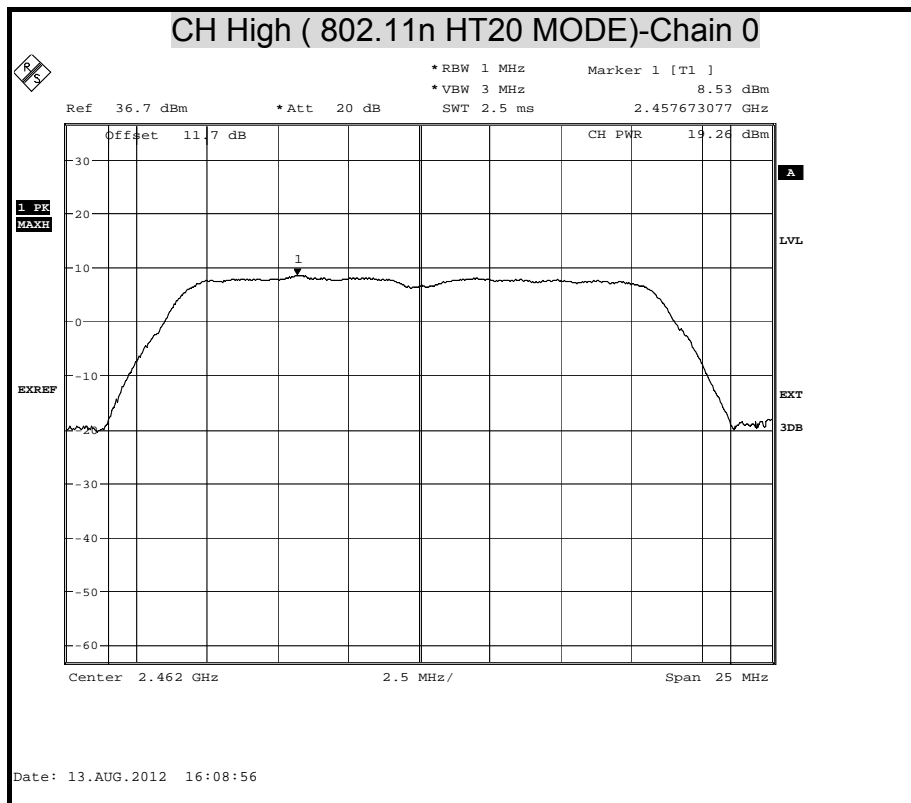



MAXIMUM PEAK OUTPUT POWER (802.11n HT20 MODE) Chain 1

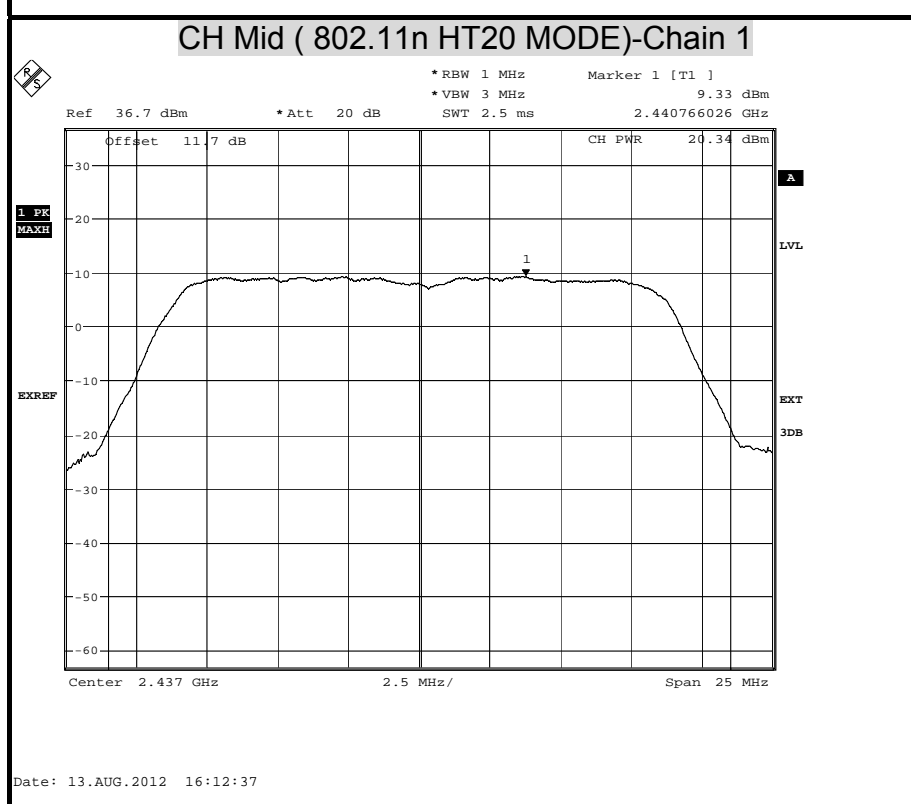
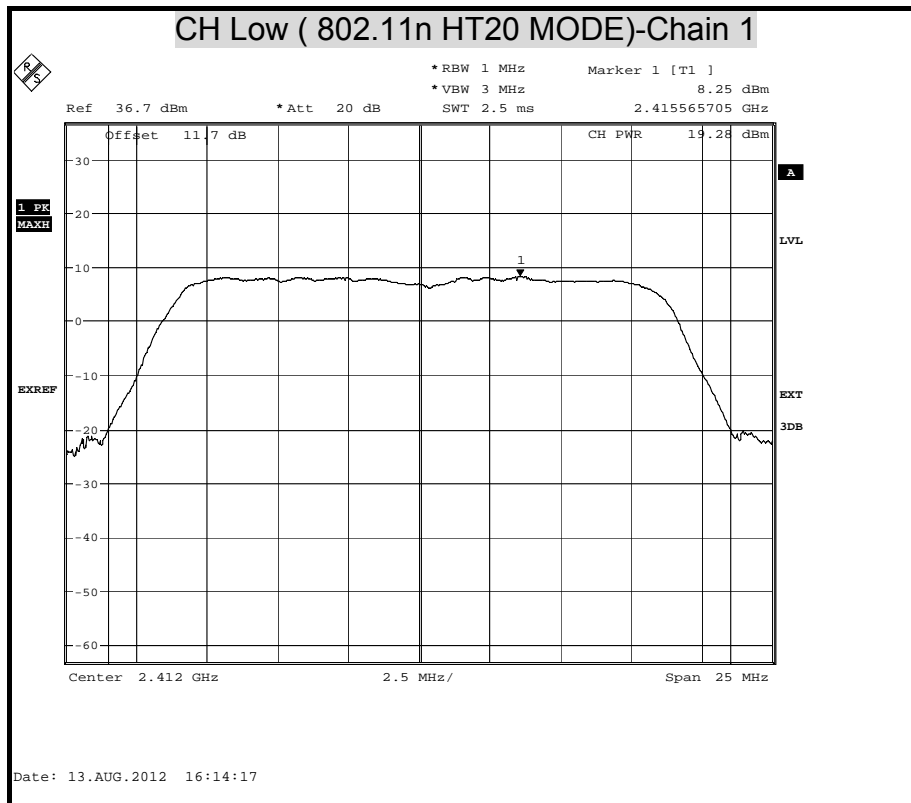

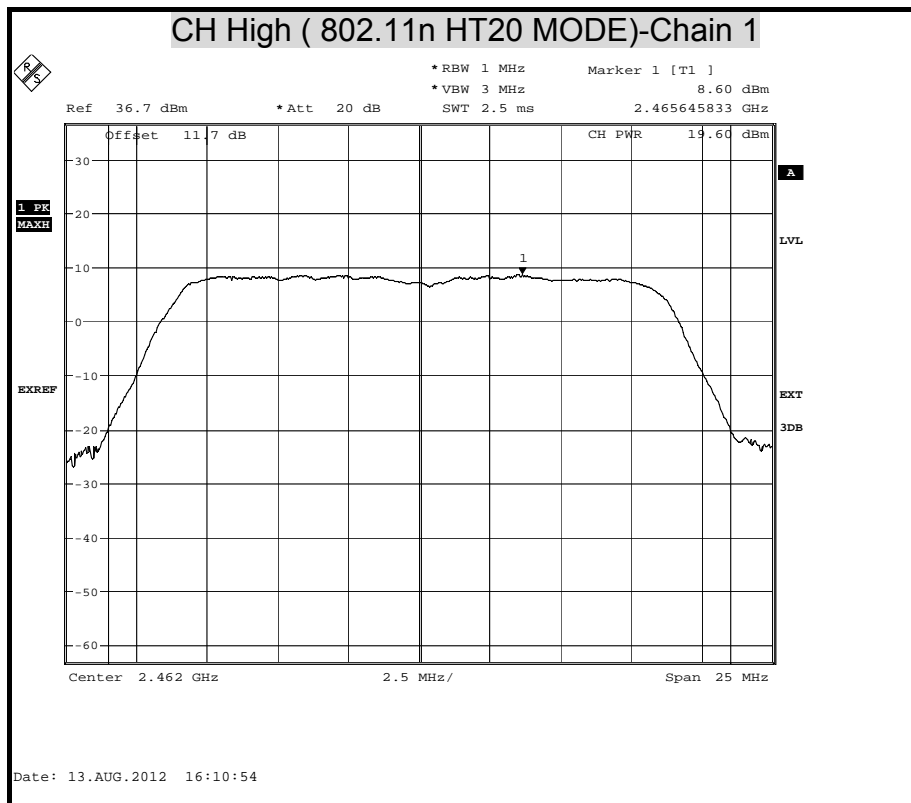



MAXIMUM PEAK OUTPUT POWER (802.11n HT40 MODE) Chain 0

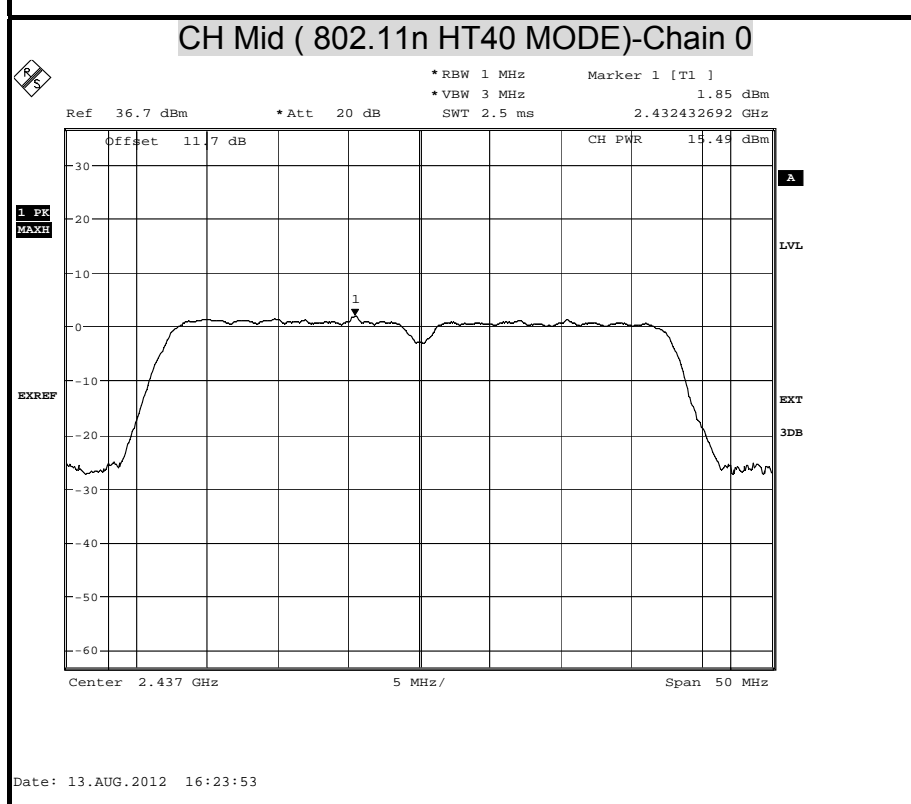
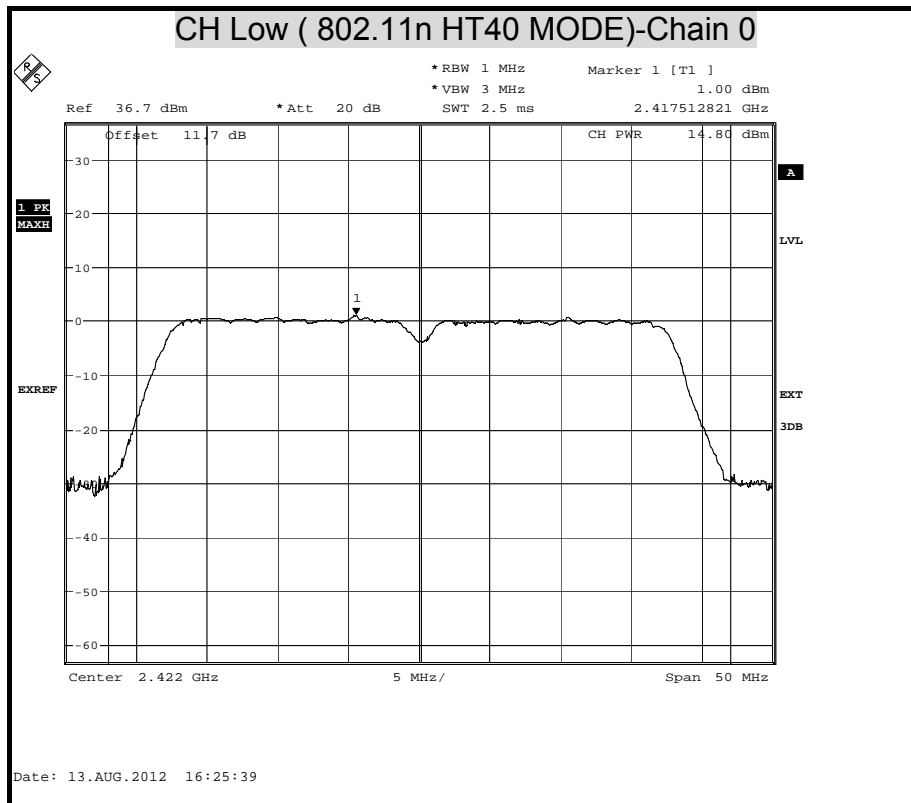

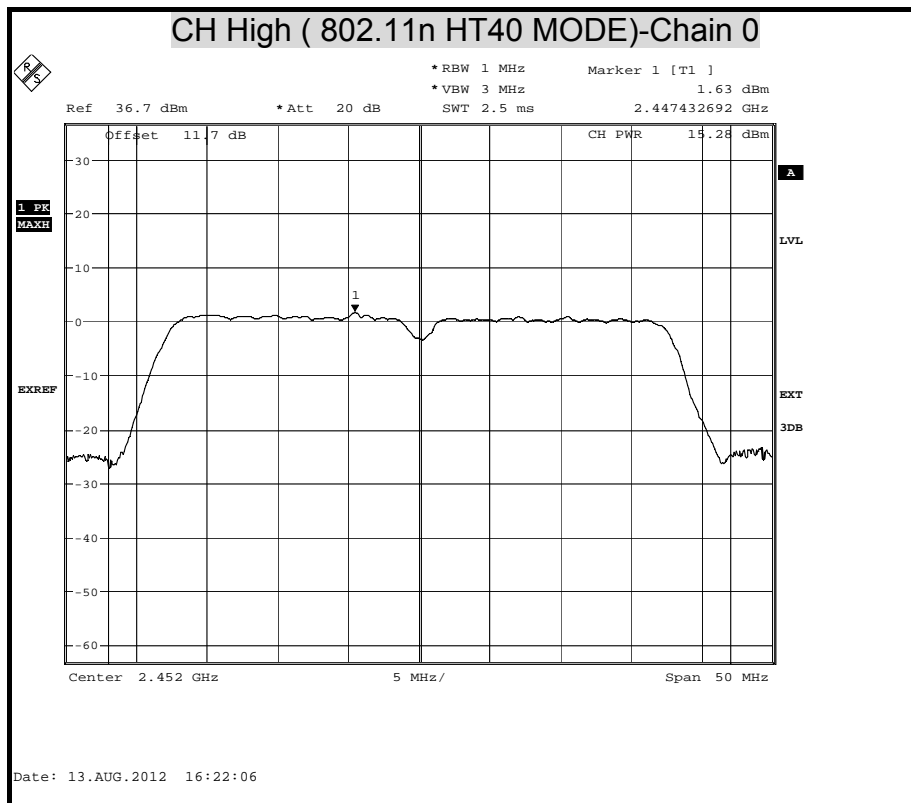



MAXIMUM PEAK OUTPUT POWER (802.11n HT40 MODE) Chain 1

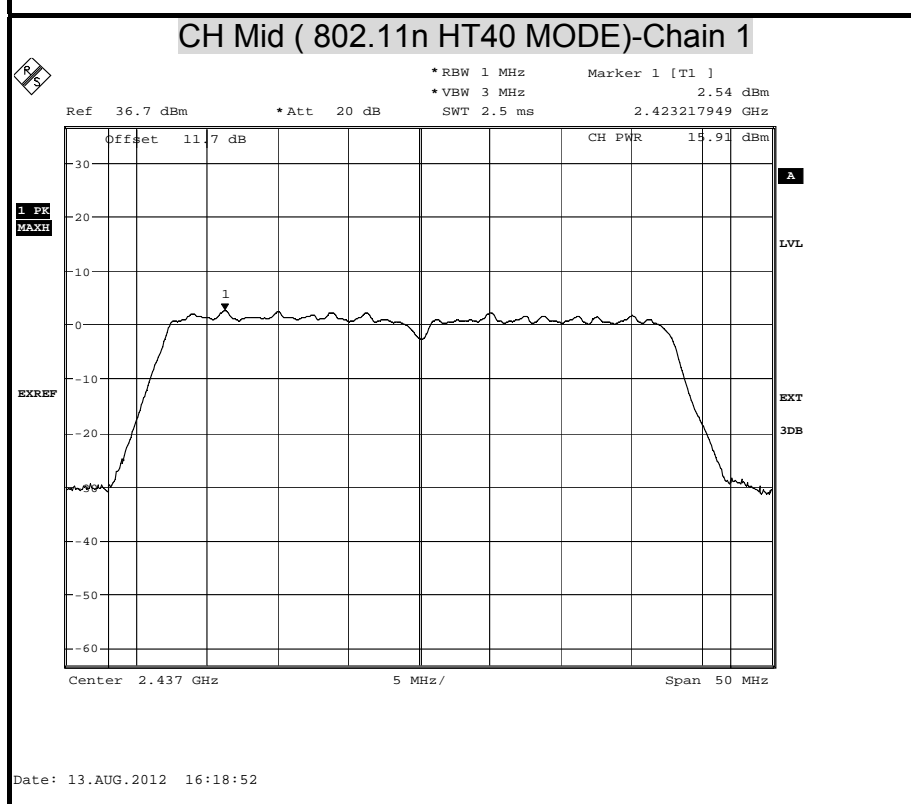
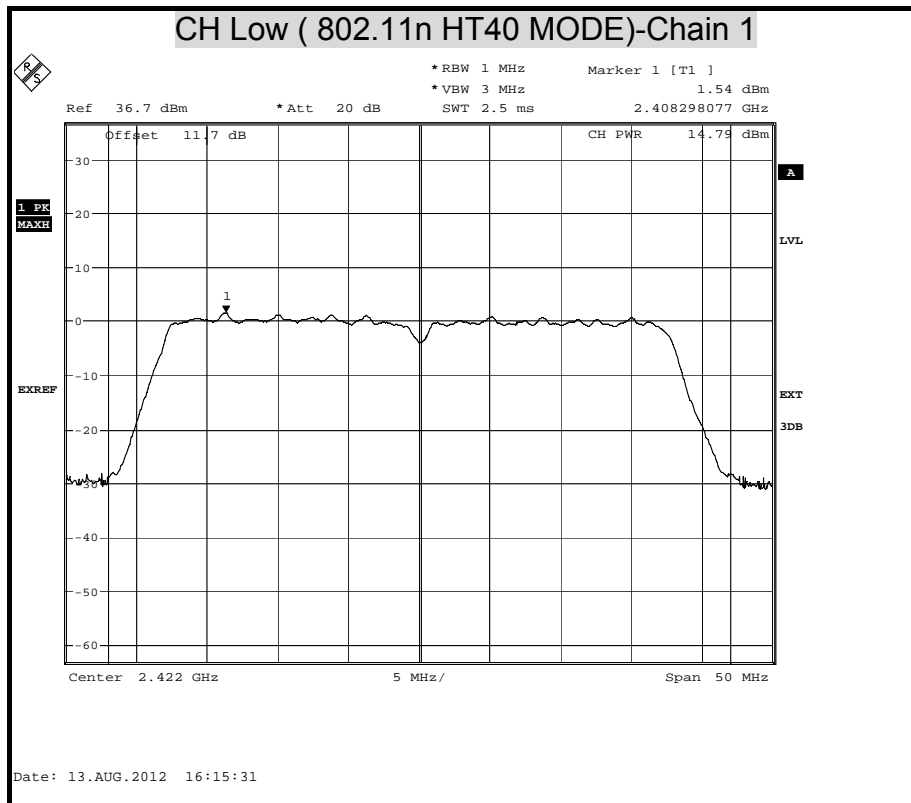

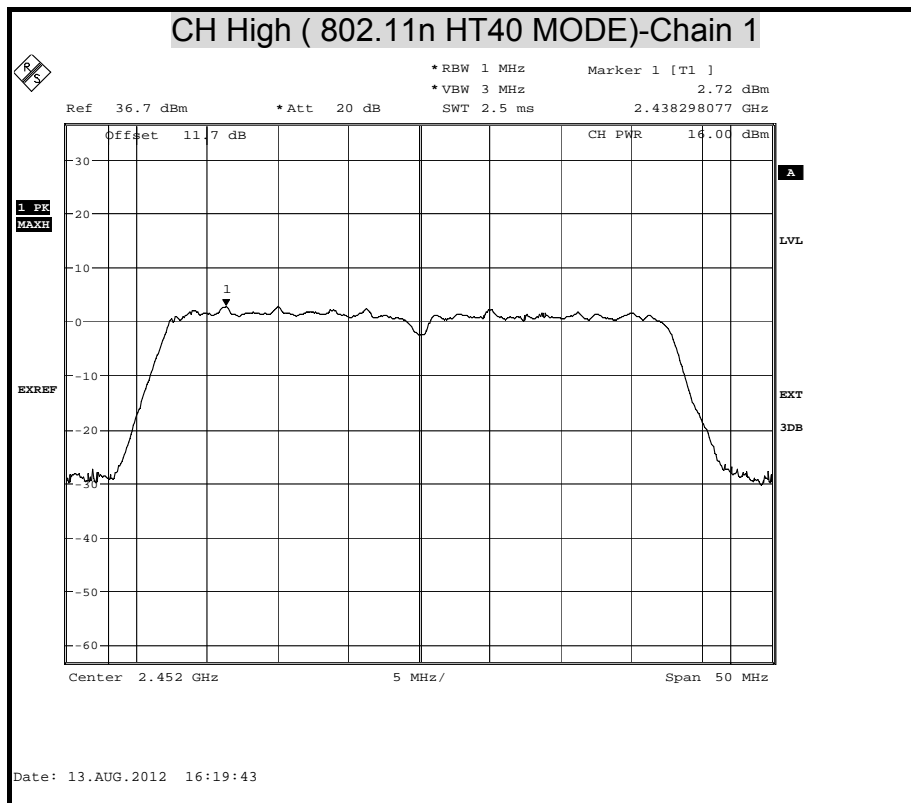



AVERAGE (802.11b MODE)

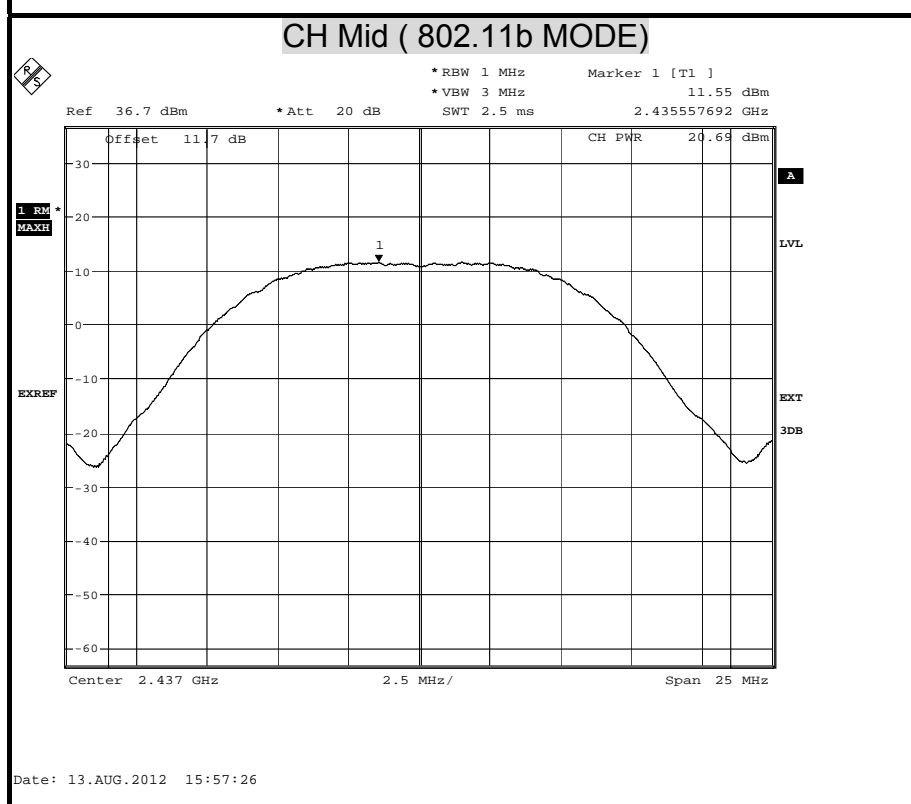
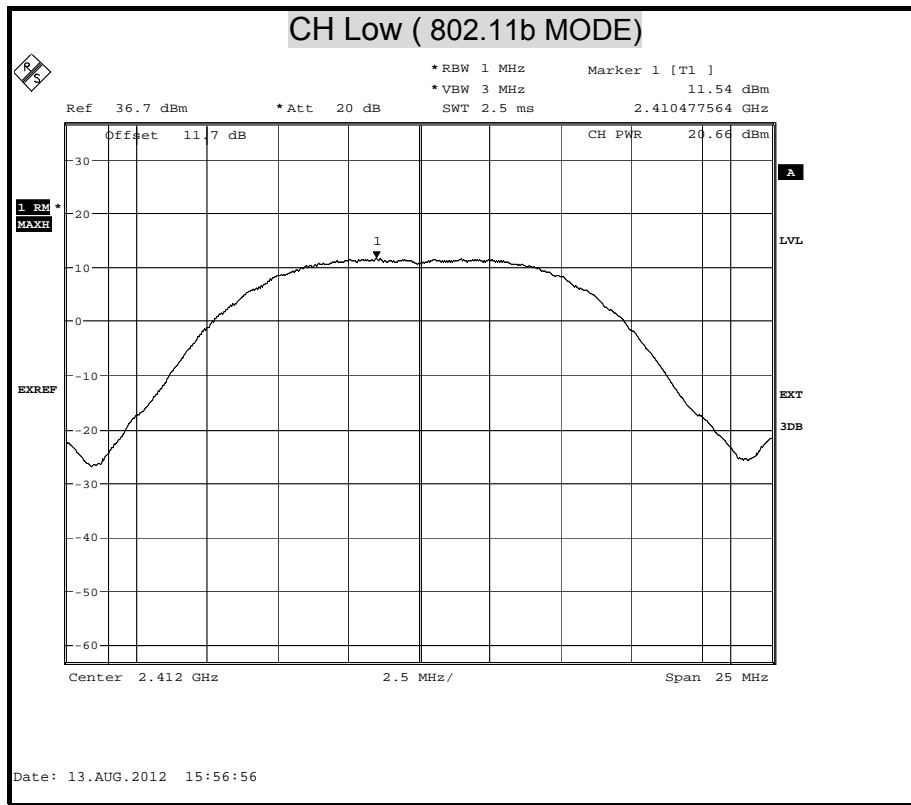

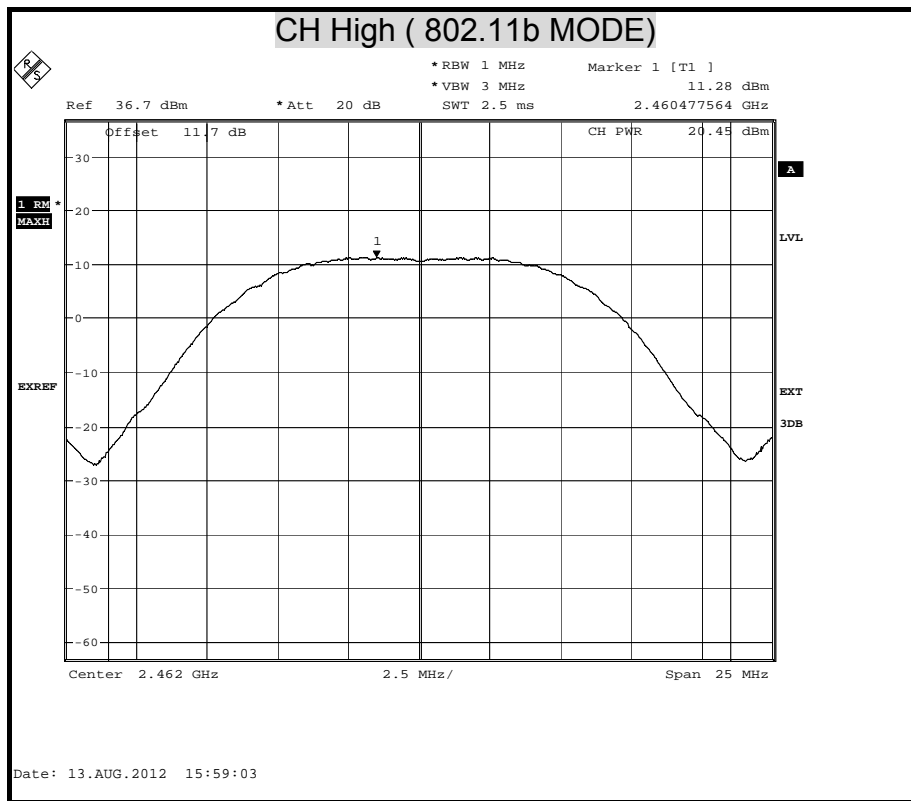



AVERAGE (802.11g MODE)

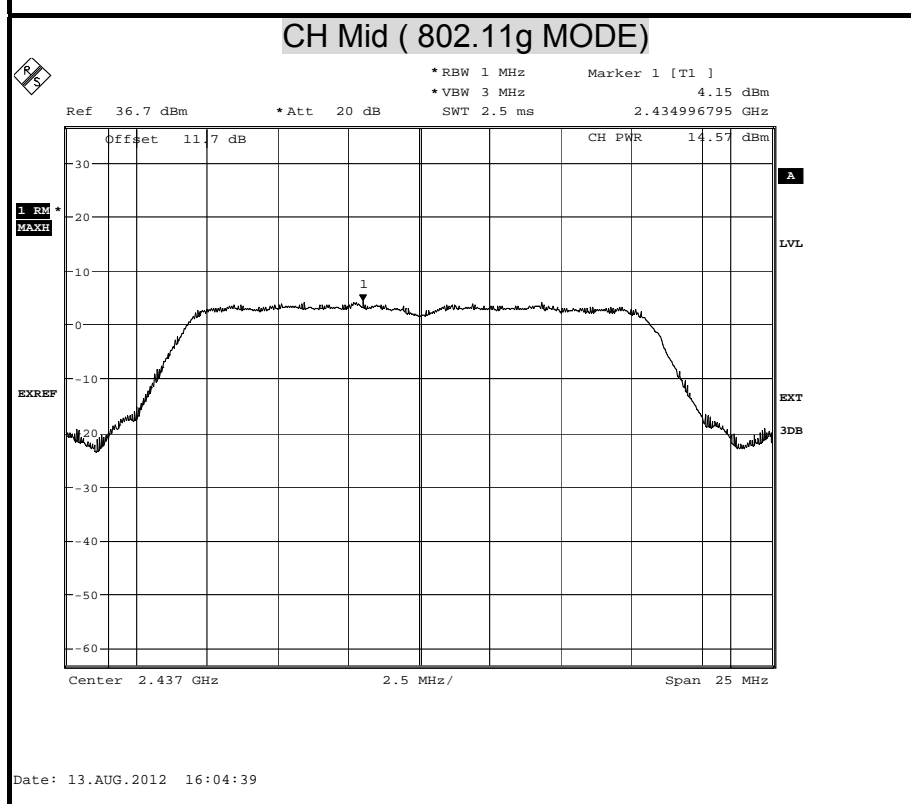
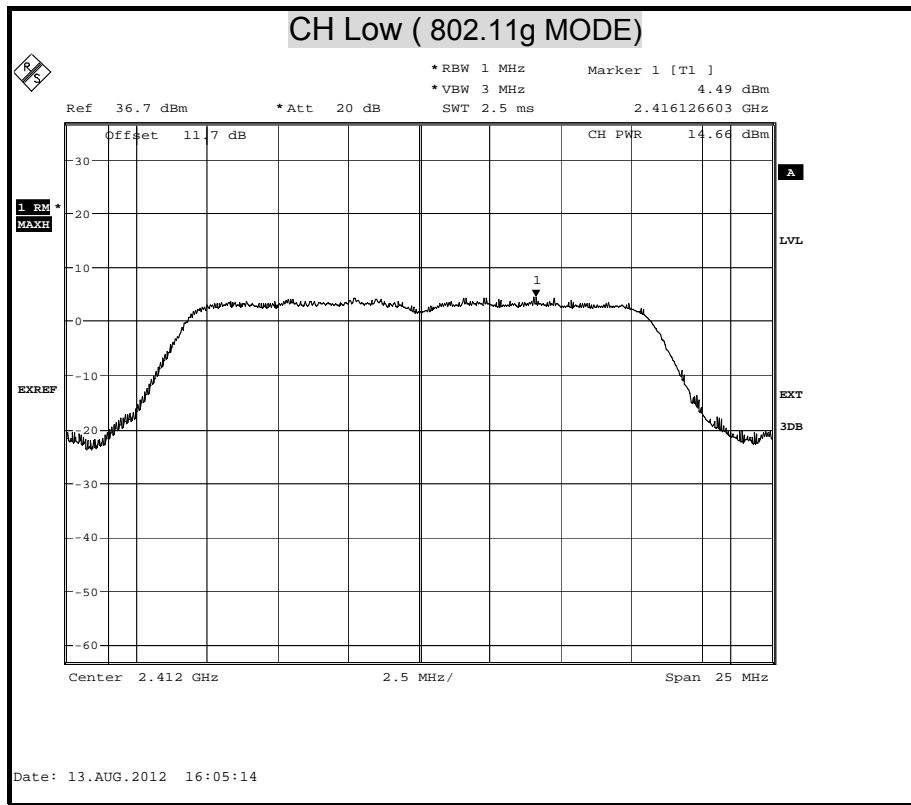

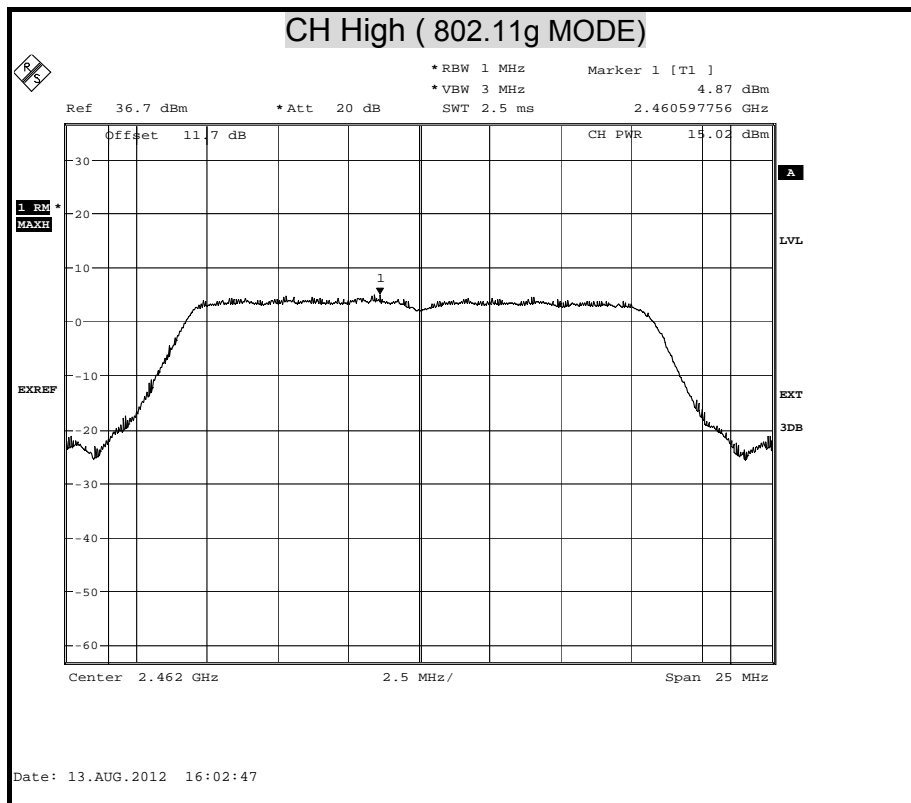



AVERAGE (802.11n HT20 MODE) Chain 0

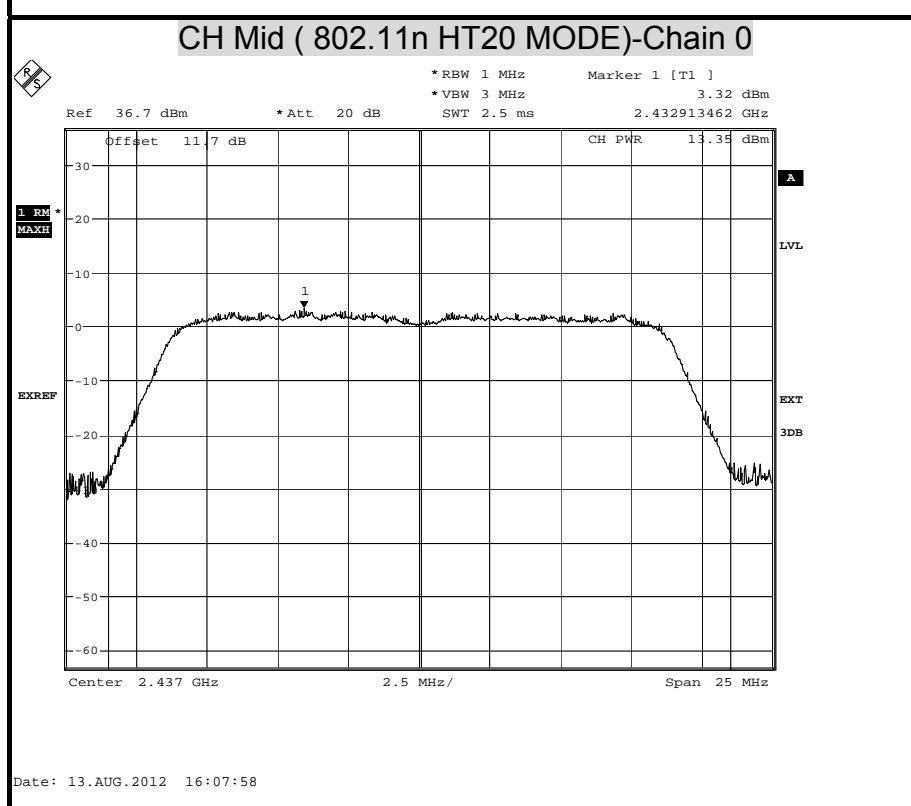
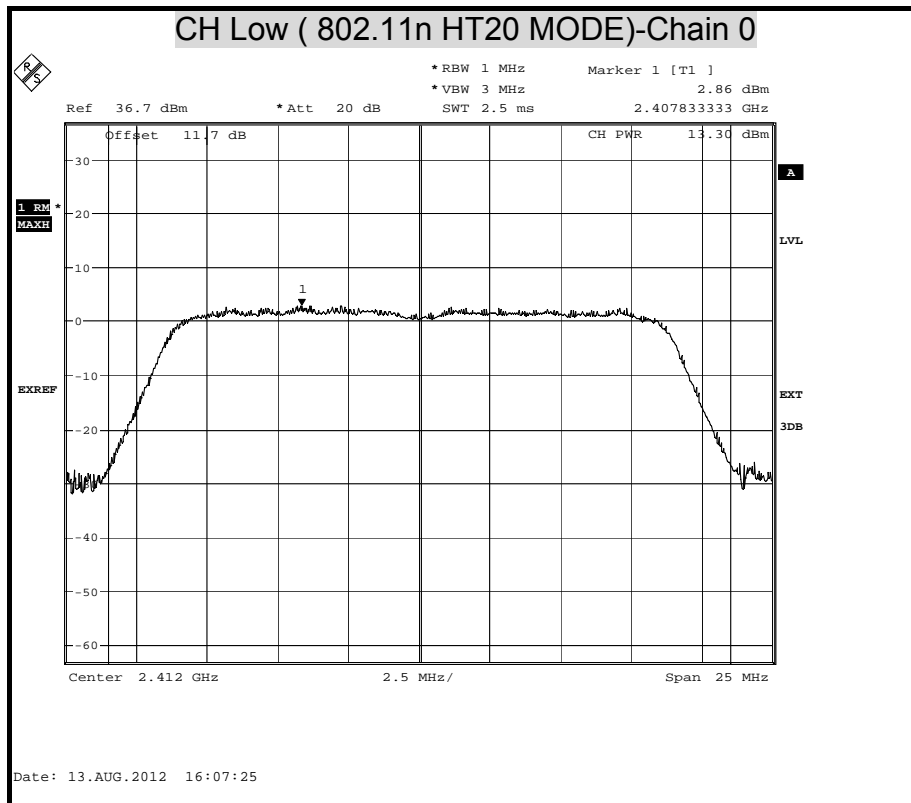

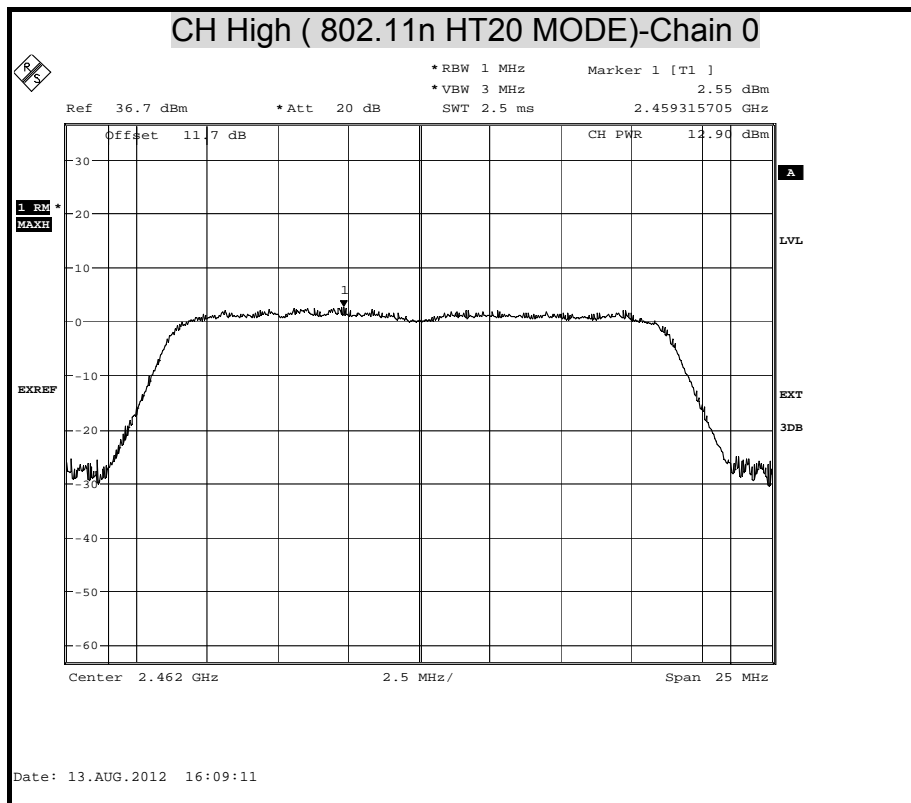



AVERAGE (802.11n HT20 MODE) Chain 1

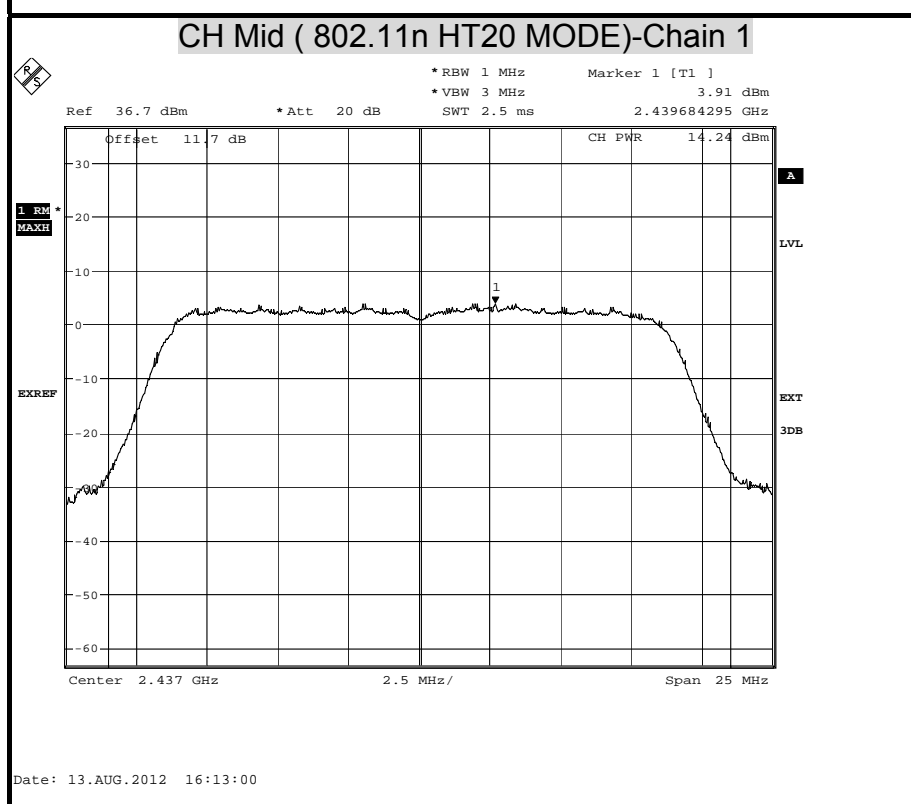
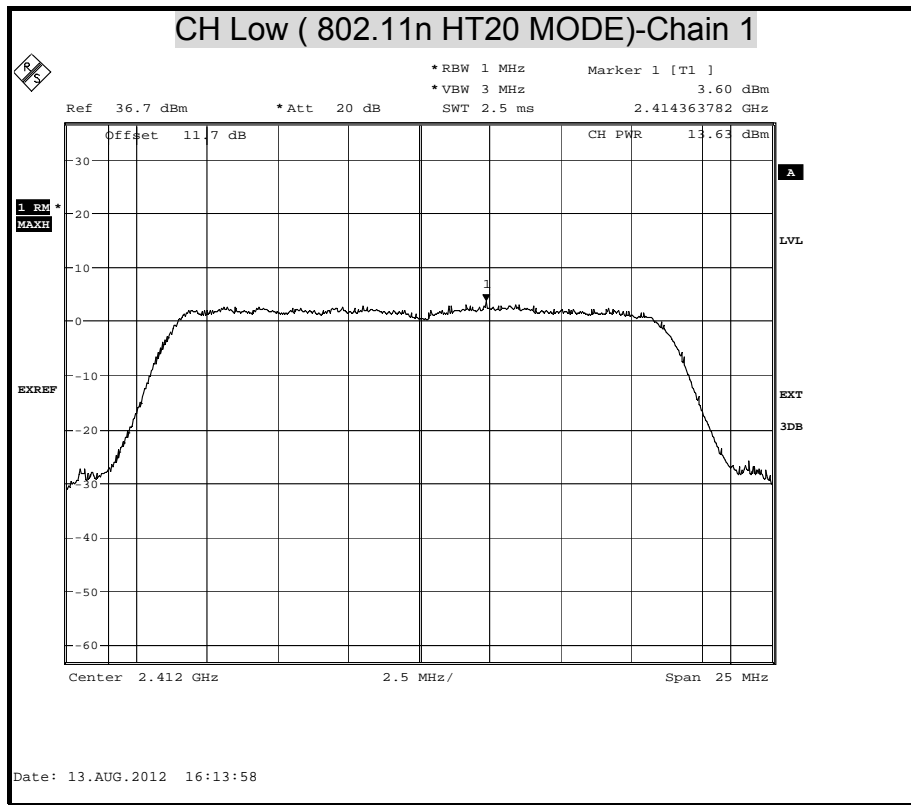

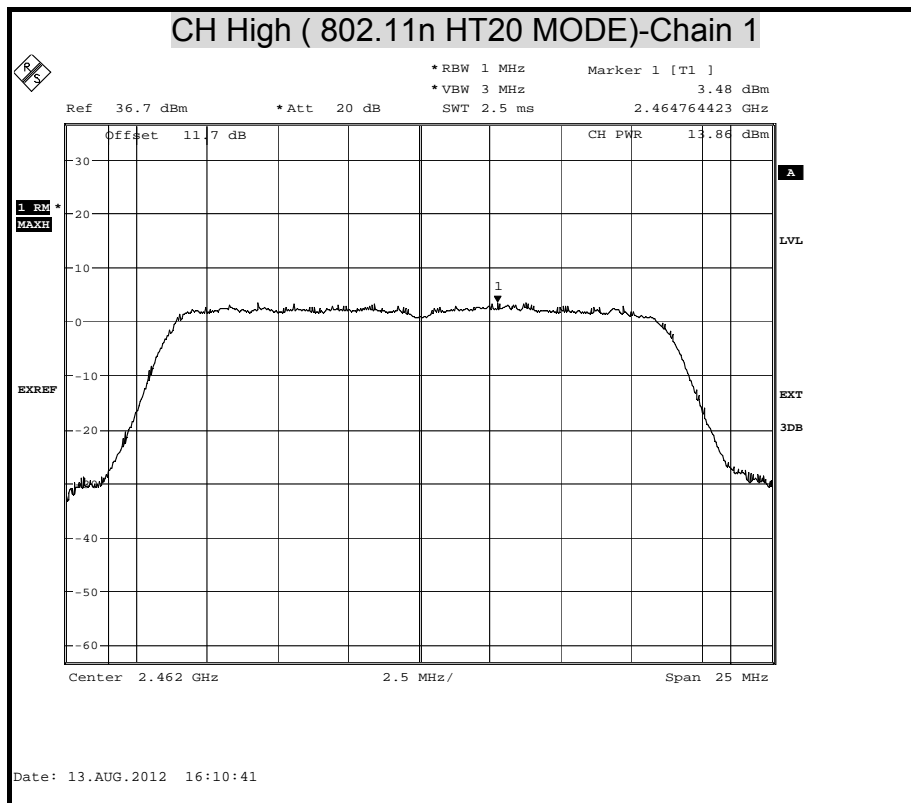



AVERAGE (802.11n HT40 MODE) Chain 0

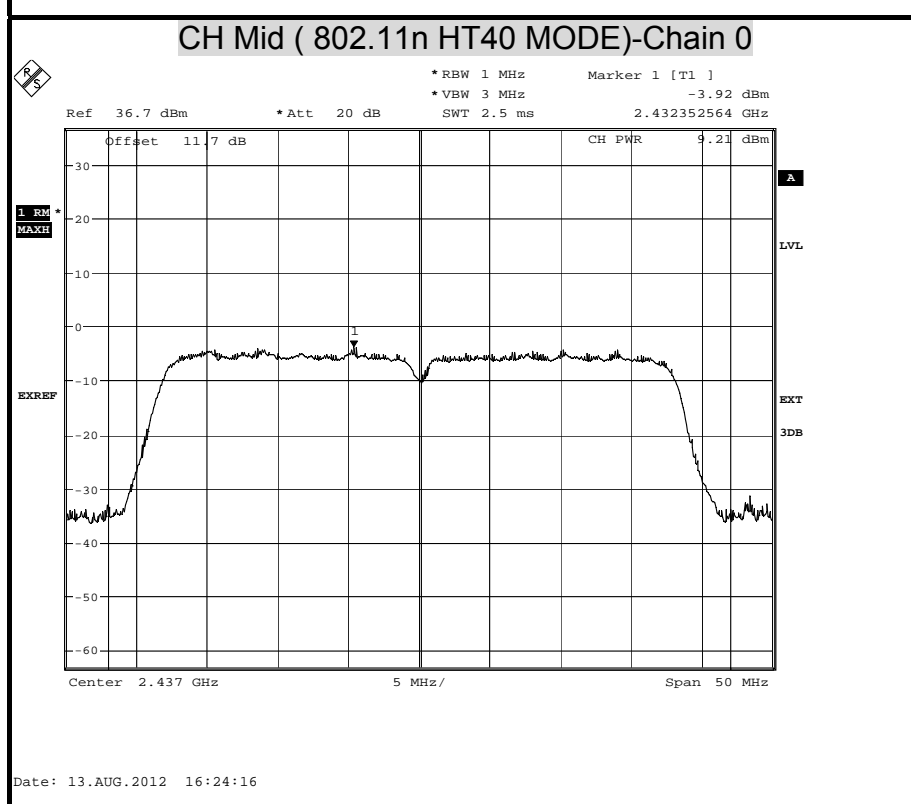
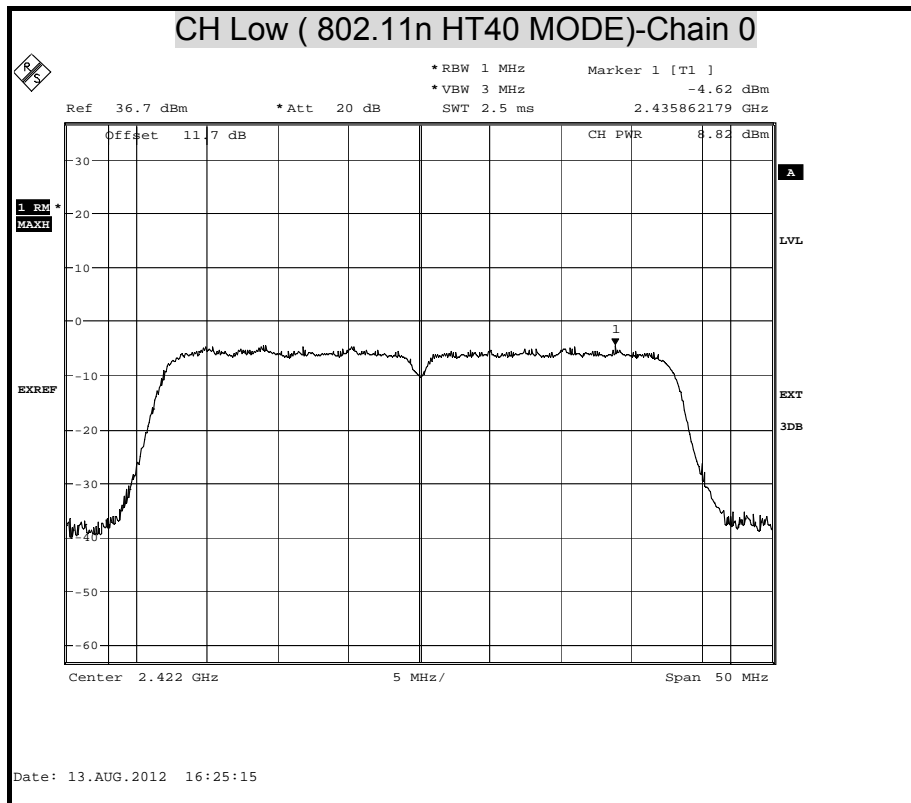

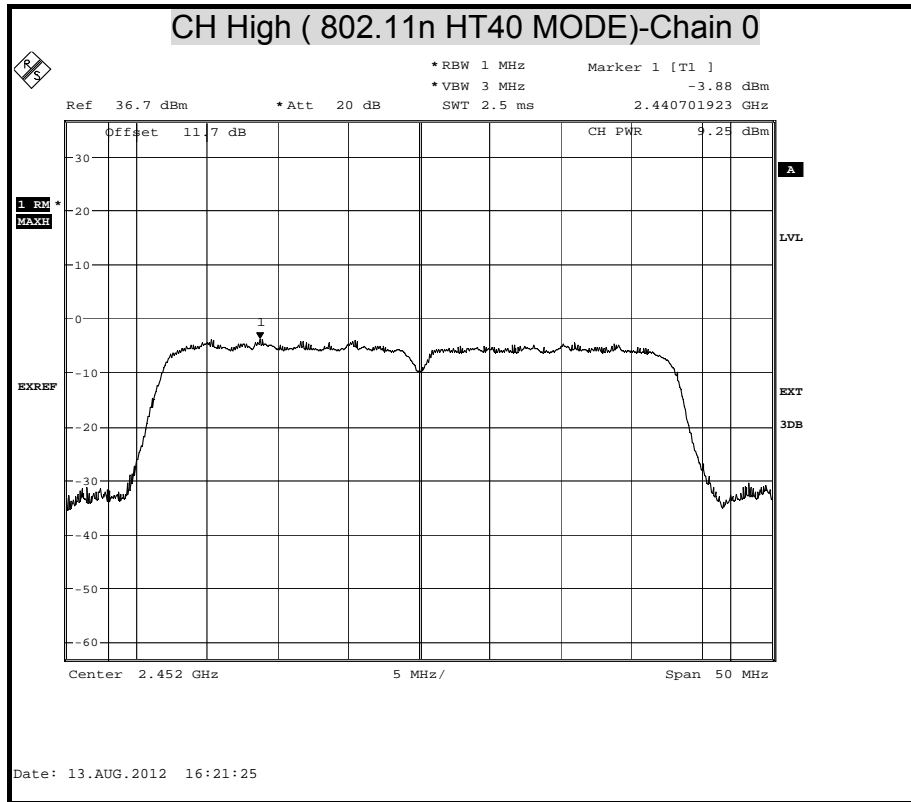



AVERAGE (802.11n HT40 MODE) Chain 1

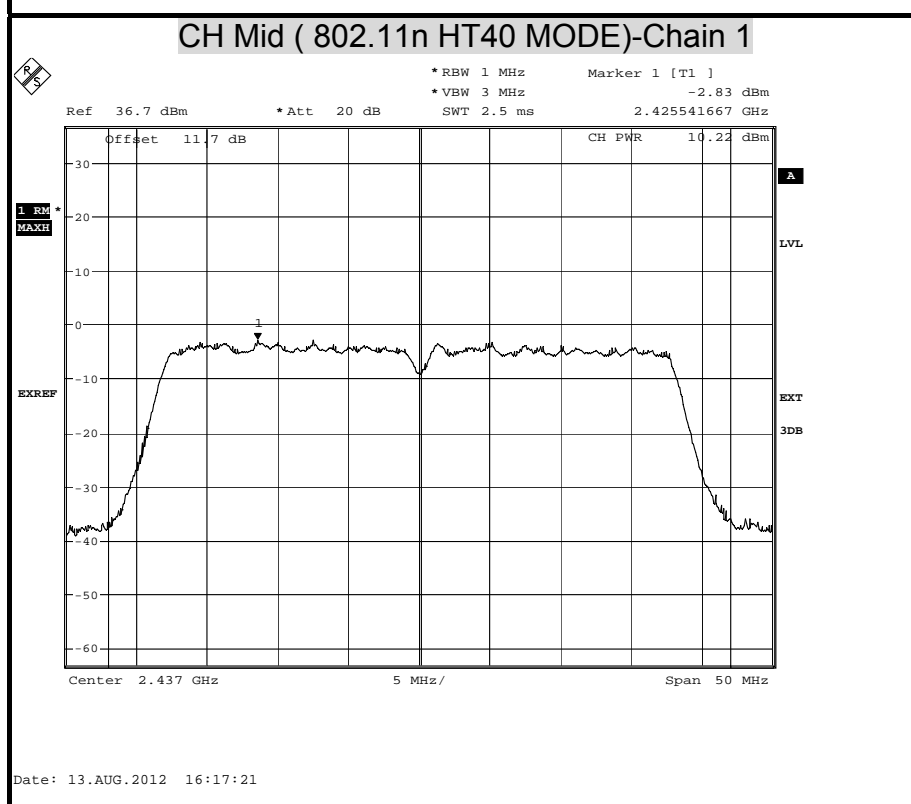
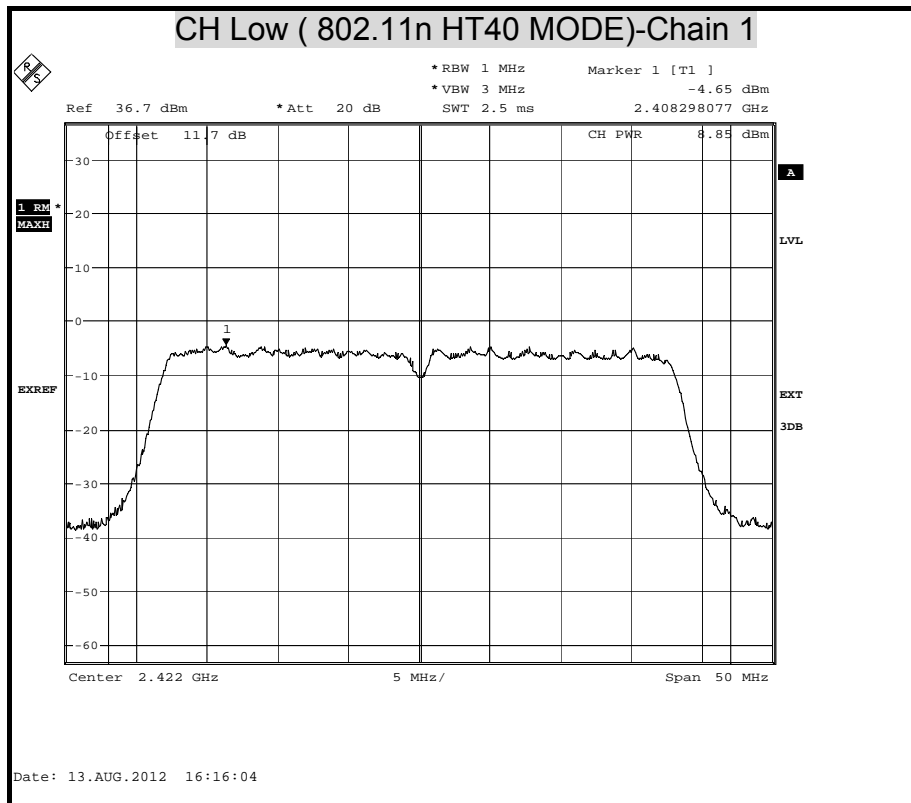

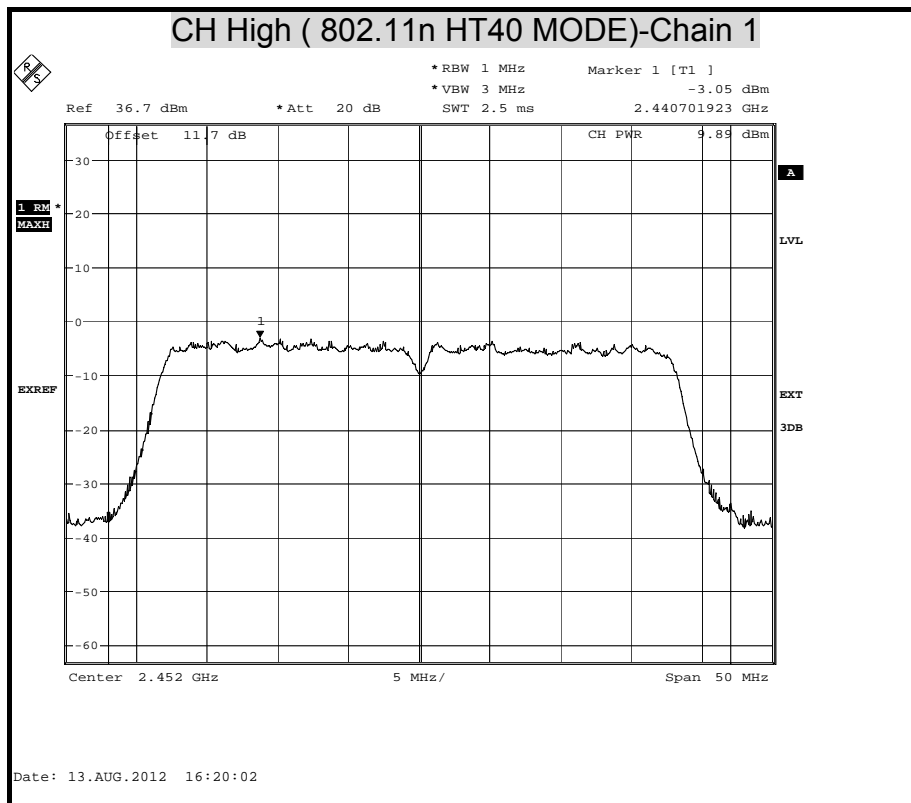



8.4 POWER SPECTRAL DENSITY

LIMIT

§ 15.247(e) For digitally modulated systems, the power spectral density conducted from the intentional radiator to the antenna shall not greater than 8 dBm in any 3 kHz band during any time interval of continuous transmission.

TEST EQUIPMENTS

Name of Equipment	Manufacturer	Model	Serial Number	Calibration Due
Spectrum Analyzer	R&S	FSU	200789	SEP. 29, 2012

TEST SETUP

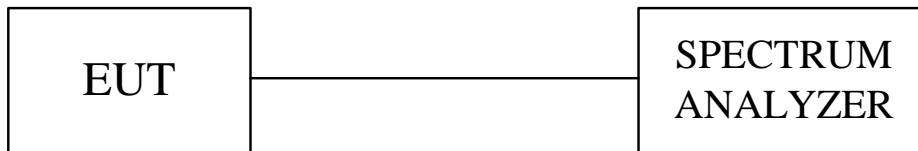

TEST PROCEDURE

The tests were performed in accordance with KDB 558074 5.3.1.

5.3.1 Measurement Procedure PKPSD:

1. Use this procedure when the maximum peak conducted output power in the fundamental emission is used to demonstrate compliance.
2. Set the RBW = 100 kHz.
3. Set the VBW ≥ 300 kHz.
4. Set the span to 5-30 % greater than the EBW.
5. Detector = peak.
6. Sweep time = auto couple.
7. Trace mode = max hold.
8. Allow trace to fully stabilize.
9. Use the peak marker function to determine the maximum power level in any 100 kHz band segment within the fundamental EBW.
10. Scale the observed power level to an equivalent value in 3 kHz by adjusting (reducing) the measured power by a bandwidth correction factor (BWCF) where $BWCF = 10\log(3\text{ kHz}/100\text{ kHz} = -15.2\text{ dB})$.
11. The resulting peak PSD level must be ≤ 8 dBm.



TEST RESULTS

IEEE 802.11b mode

Table with 8 columns: Channel, Frequency (MHz), Reading (dBm), BWCF (dB), PPSD (dBm), Limit (dBm), Margin (dB), Pass / Fail. Rows for Low, Middle, High channels.

NOTE : 1. At final test to get the worst-case emission at 1Mbps long. 2. The cable assembly insertion loss of 11.7dB (including 10 dB pad and 1.7 dB cable) was Entered as an offset in the spectrum analyzer to allow for direct reading of power.

IEEE 802.11g mode

Table with 8 columns: Channel, Frequency (MHz), Reading (dBm), BWCF (dB), PPSD (dBm), Limit (dBm), Margin (dB), Pass / Fail. Rows for Low, Middle, High channels.

NOTE : 1. At final test to get the worst-case emission at 6Mbps long. 2. The cable assembly insertion loss of 11.7dB (including 10 dB pad and 1.7 dB cable) was Entered as an offset in the spectrum analyzer to allow for direct reading of power.

IEEE 802.11n HT20 mode

Table with 11 columns: Channel, Frequency (MHz), Reading Chain0 (dBm), Reading Chain1 (dBm), BWCF (dB), PPSD Chain0 (dBm), PPSD Chain1 (dBm), PPSD Total (dBm), Limit (dBm), Margin (dB), Pass / Fail. Rows for Low, Middle, High channels.

NOTE : 1. At final test to get the worst-case emission at 13Mbps long. 2. The cable assembly insertion loss of 11.7dB (including 10 dB pad and 1.7 dB cable) was Entered as an offset in the spectrum analyzer to allow for direct reading of power.

IEEE 802.11n HT40 mode

Table with 11 columns: Channel, Frequency (MHz), Reading Chain0 (dBm), Reading Chain1 (dBm), BWCF (dB), PPSD Chain0 (dBm), PPSD Chain1 (dBm), PPSD Total (dBm), Limit (dBm), Margin (dB), Pass / Fail. Rows for Low, Middle, High channels.

NOTE : 1. At final test to get the worst-case emission at 27Mbps long. 2. The cable assembly insertion loss of 11.7dB (including 10 dB pad and 1.7 dB cable) was Entered as an offset in the spectrum analyzer to allow for direct reading of power.



POWER SPECTRAL DENSITY (IEEE 802.11b MODE)

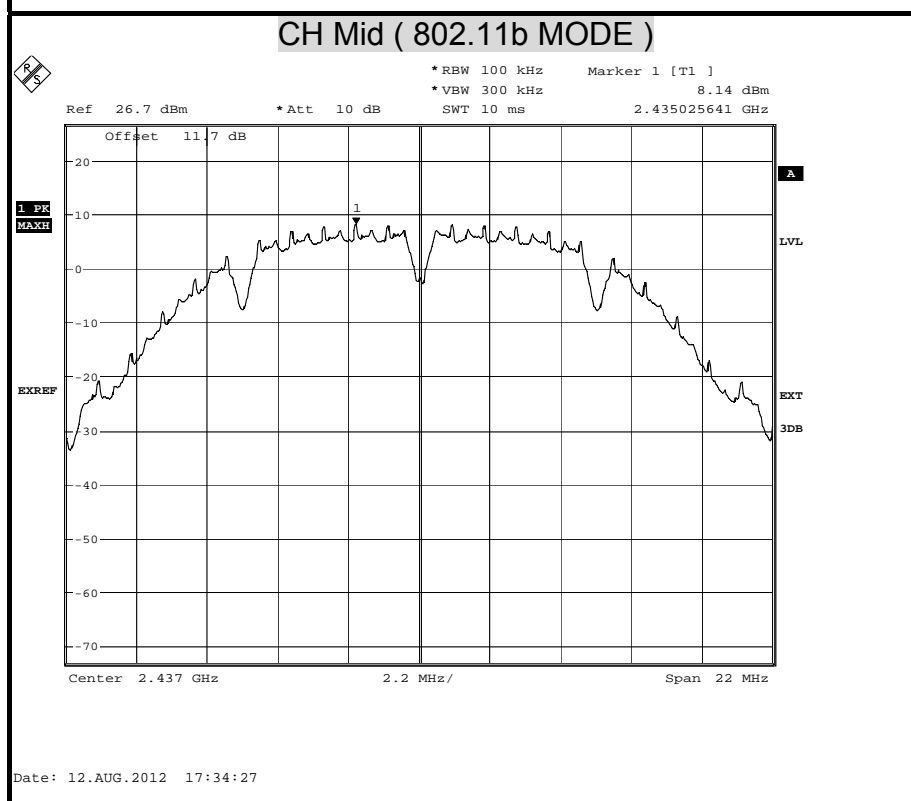
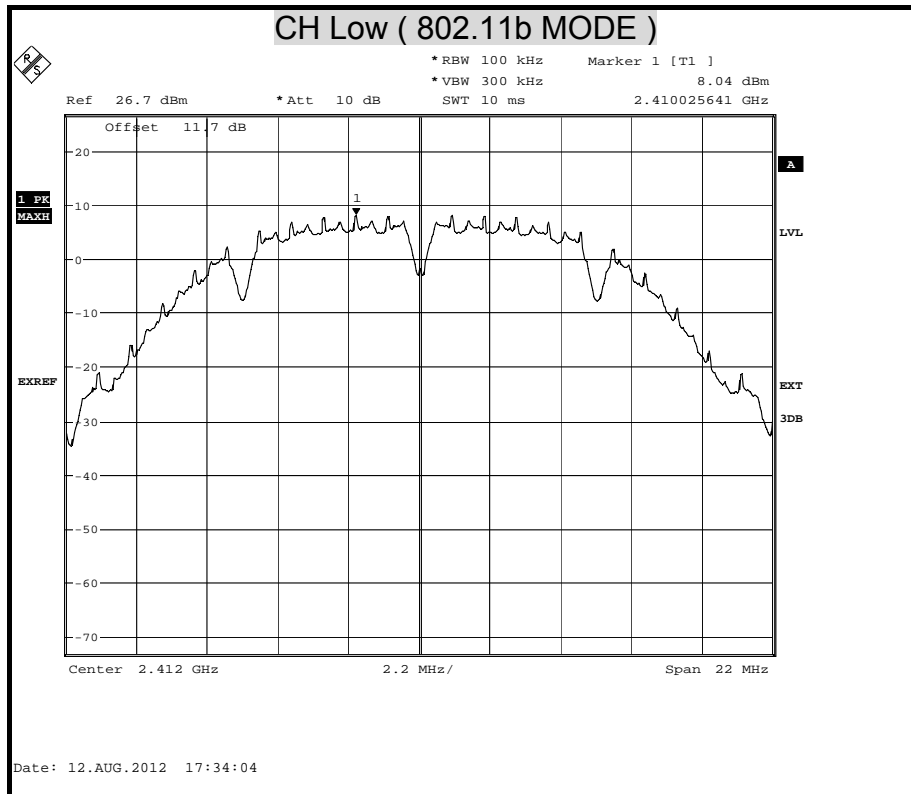

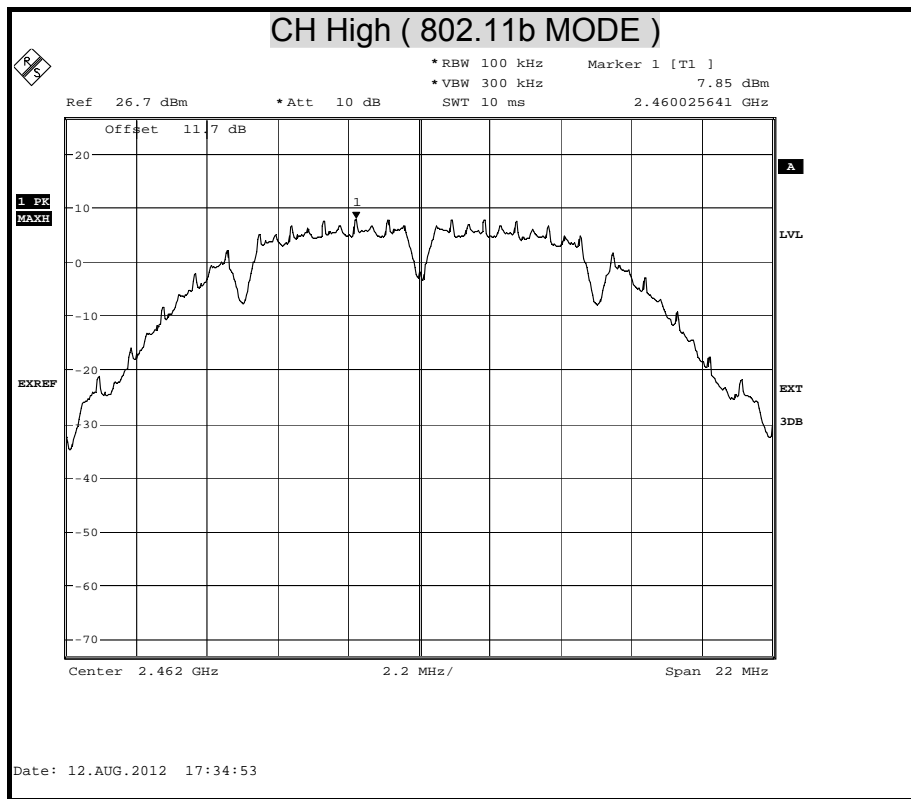



POWER SPECTRAL DENSITY (IEEE 802.11g MODE)

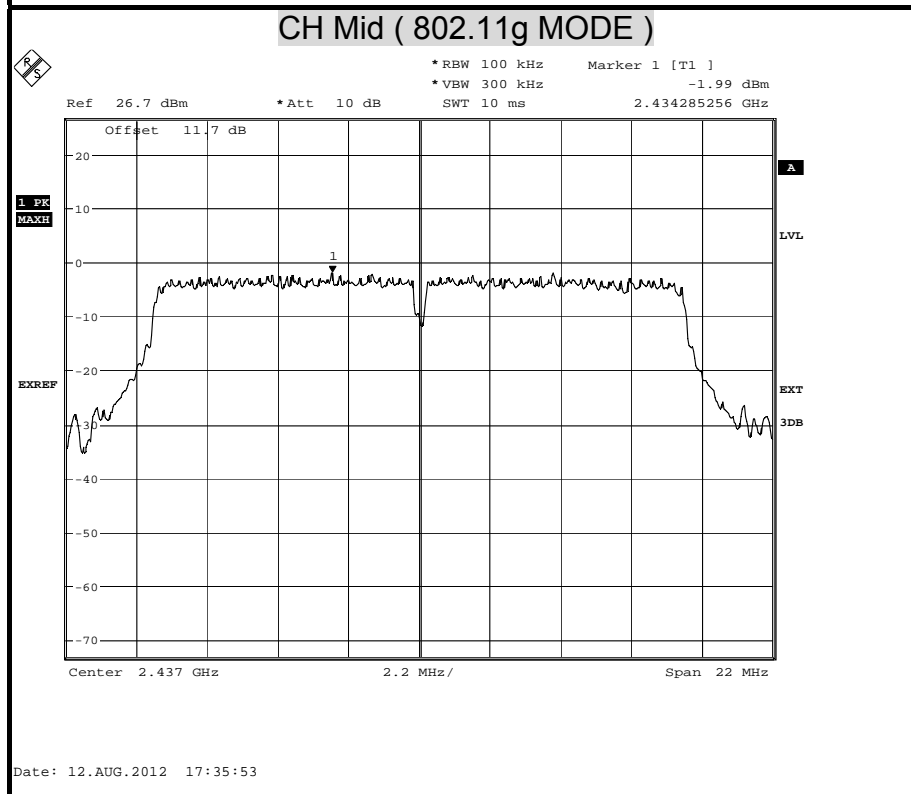
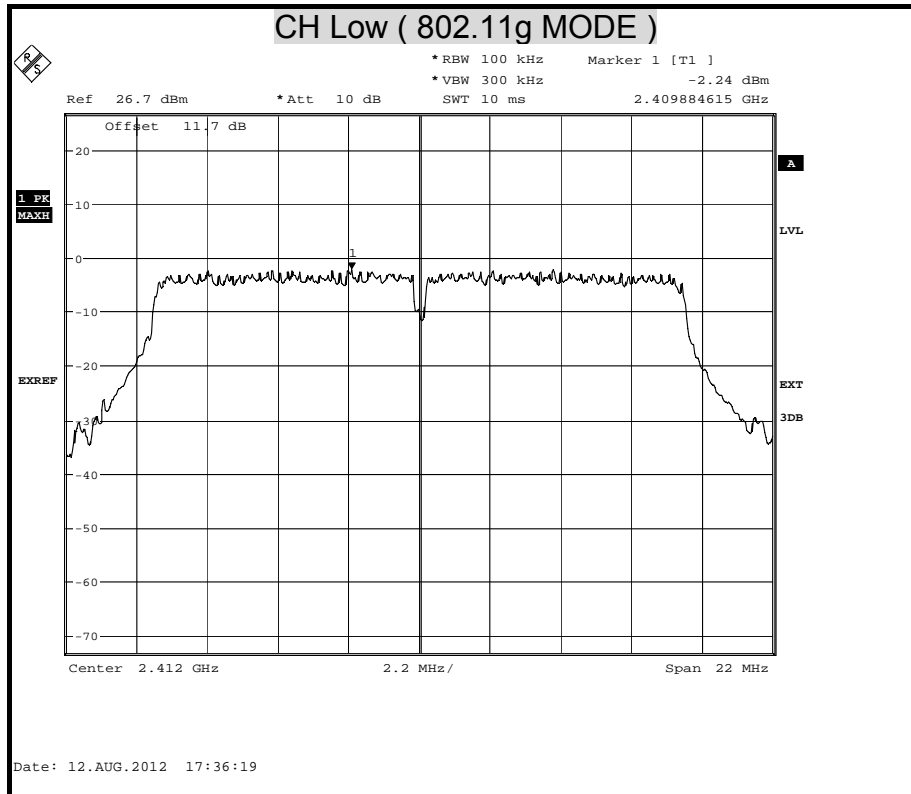

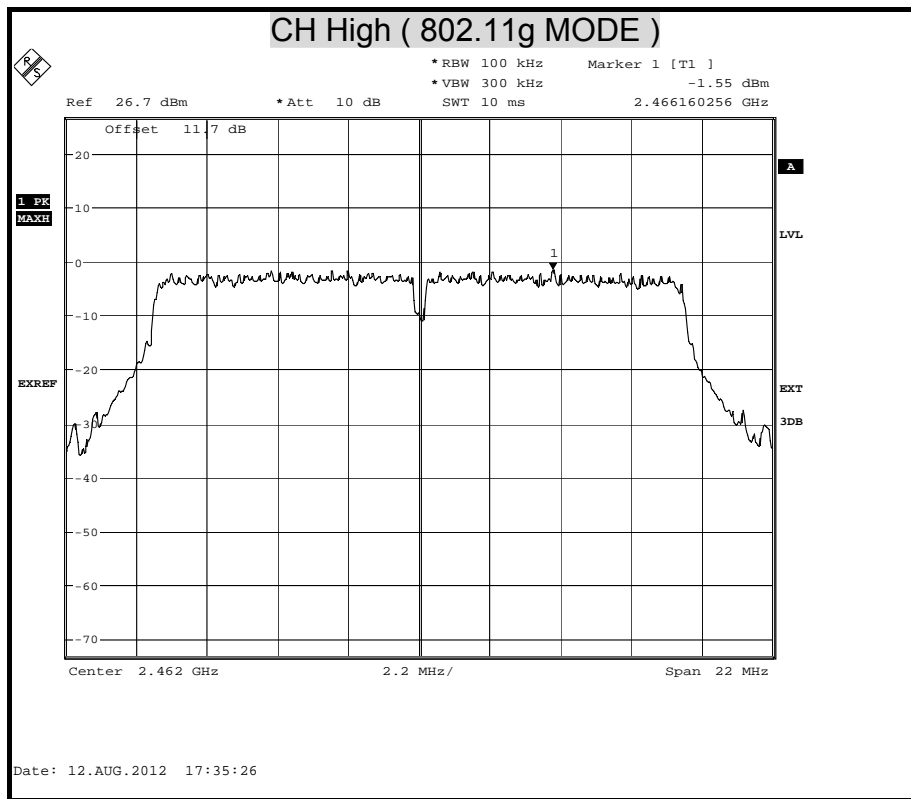



POWER SPECTRAL DENSITY (802.11n HT20 MODE)

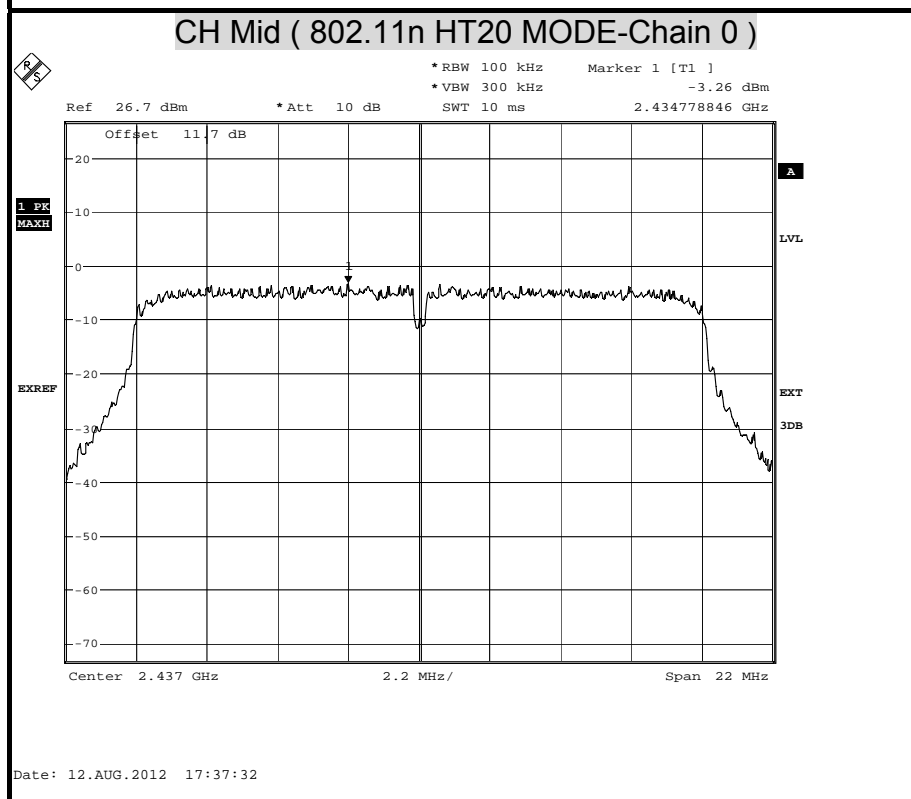
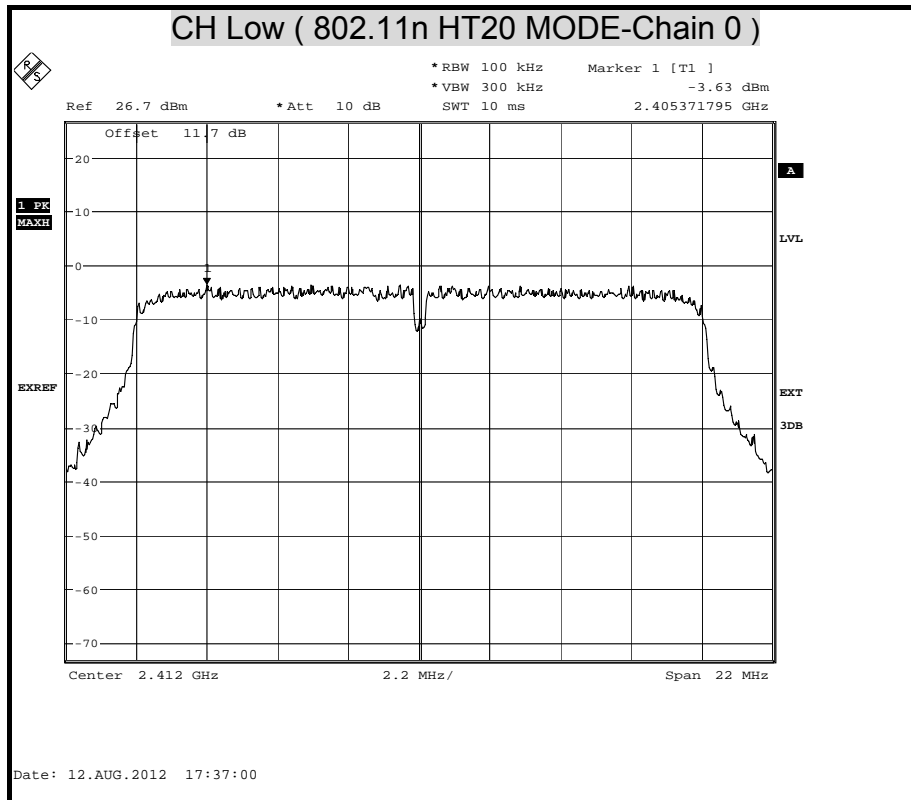

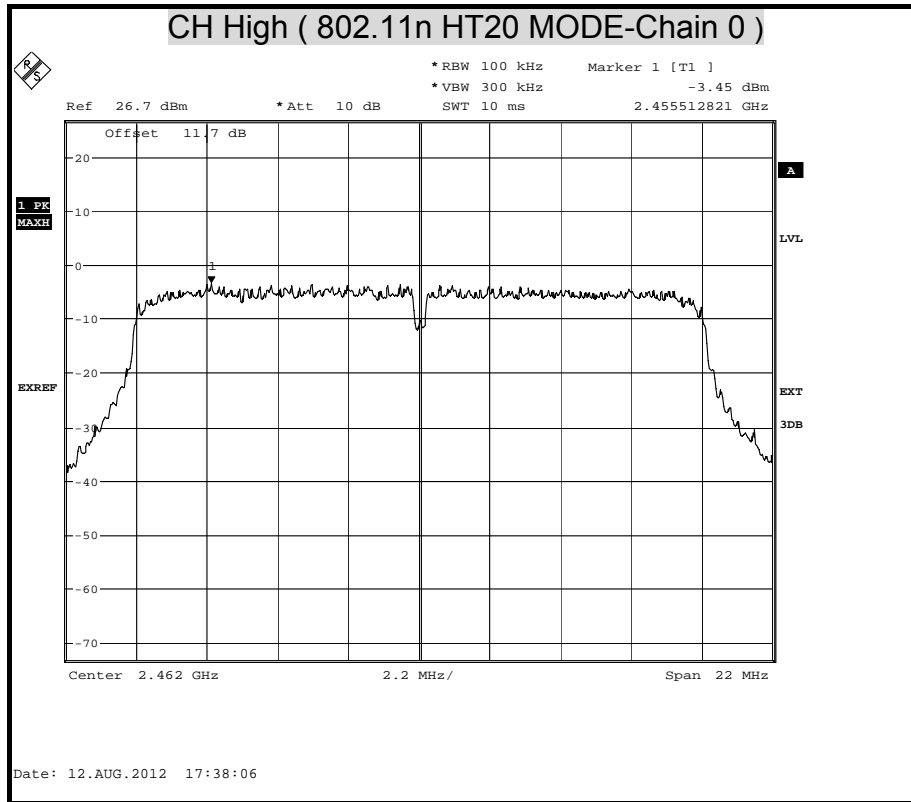



POWER SPECTRAL DENSITY (802.11n HT20 MODE)

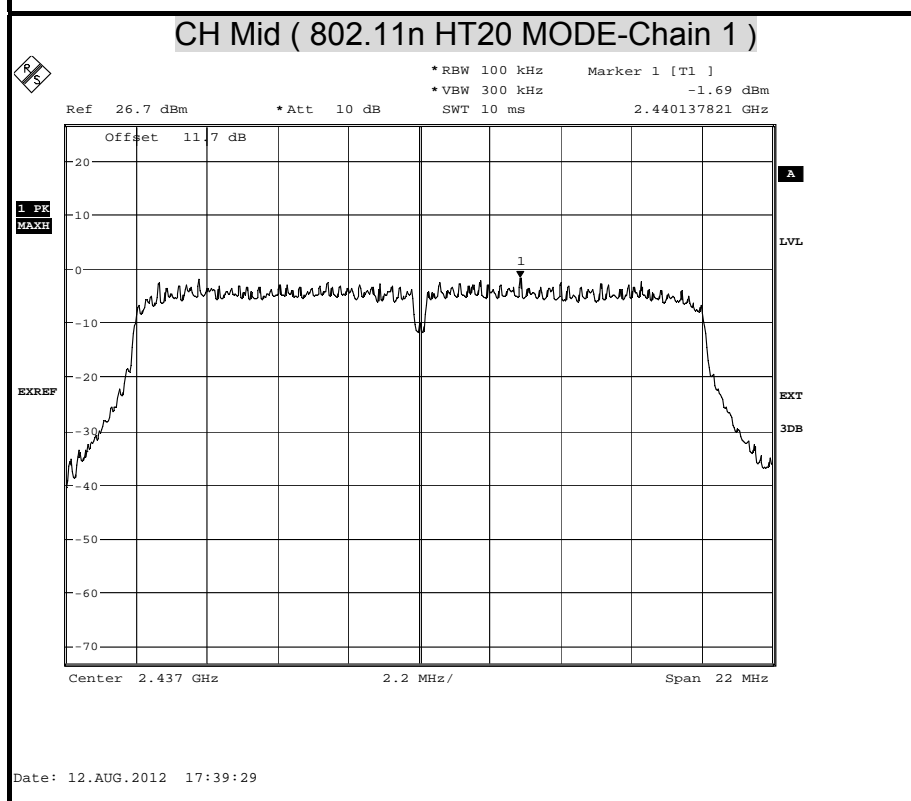
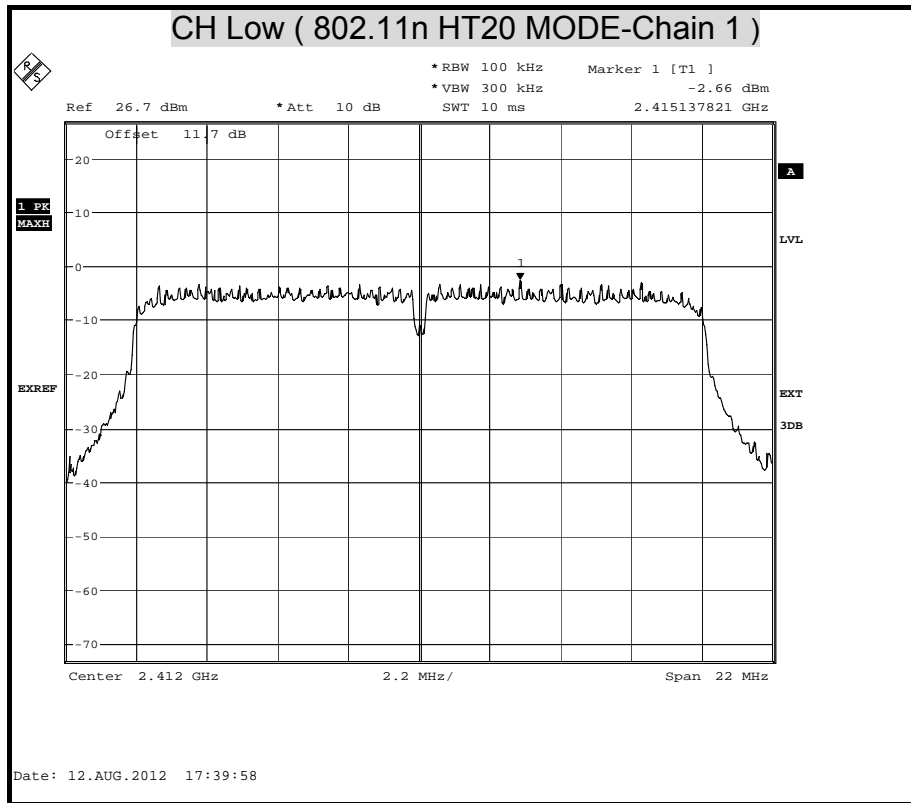

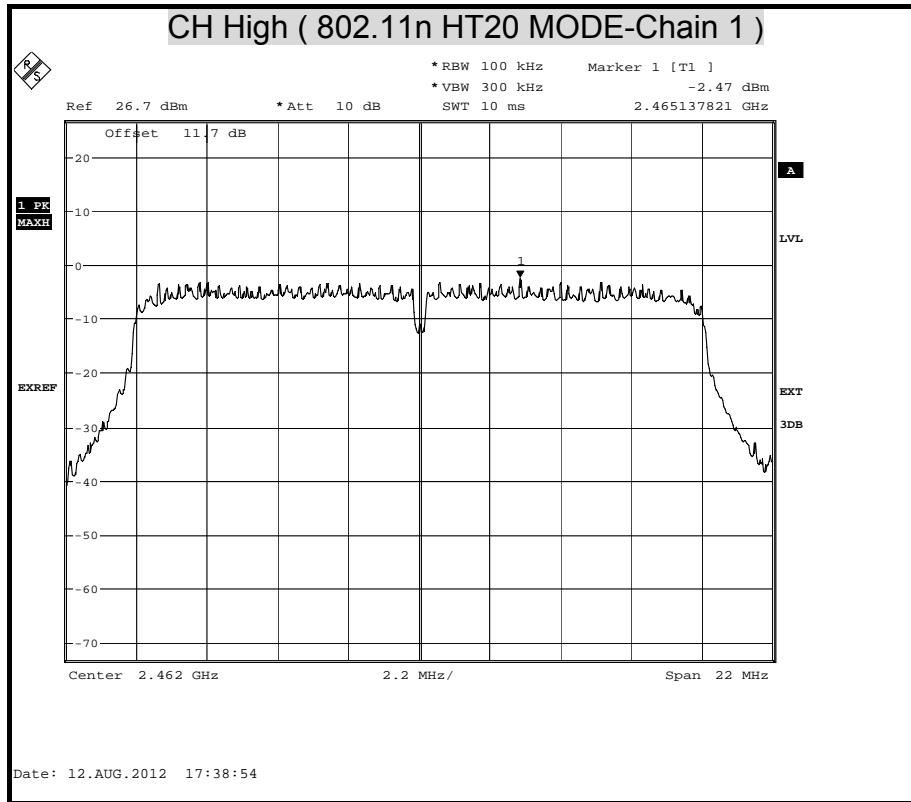



POWER SPECTRAL DENSITY (802.11n HT40 MODE)

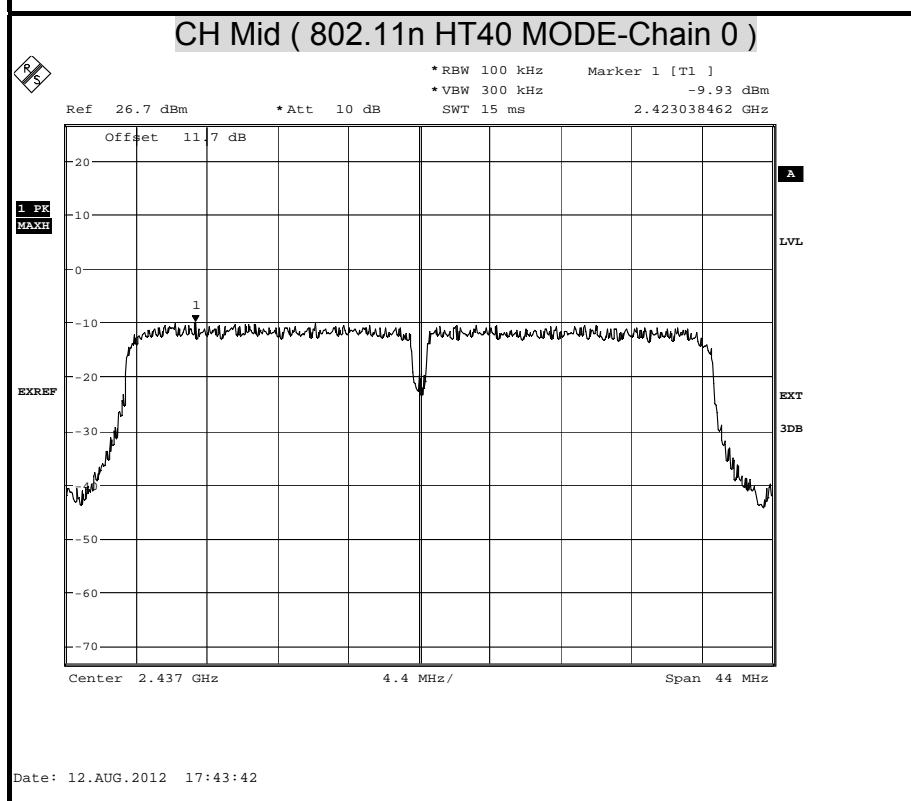
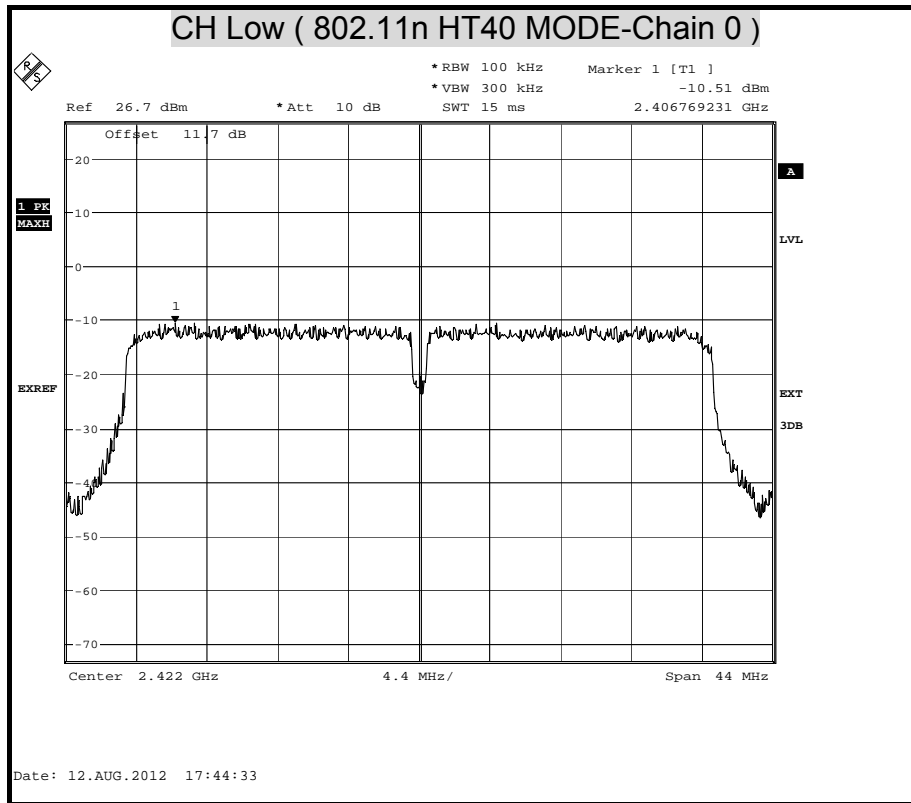

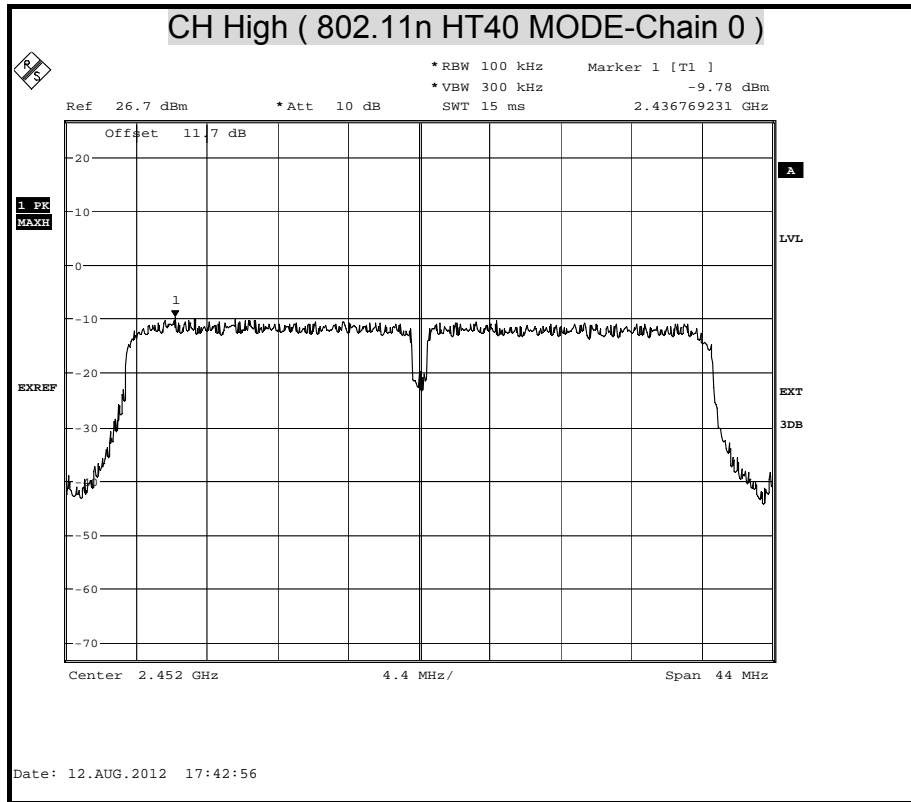



POWER SPECTRAL DENSITY (802.11n HT40 MODE)

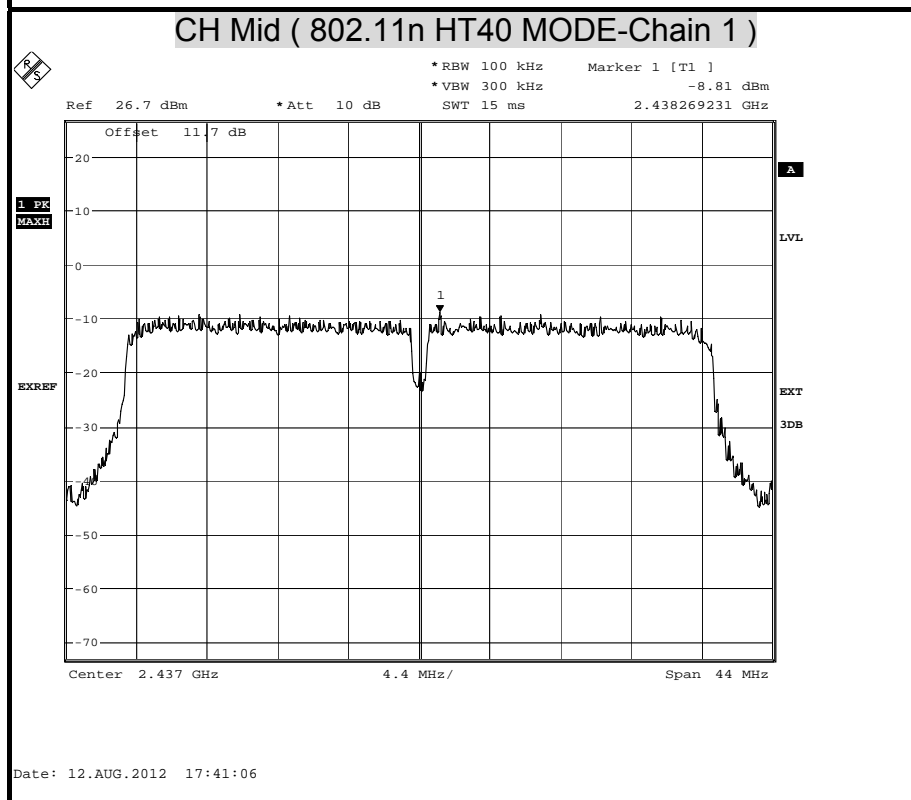
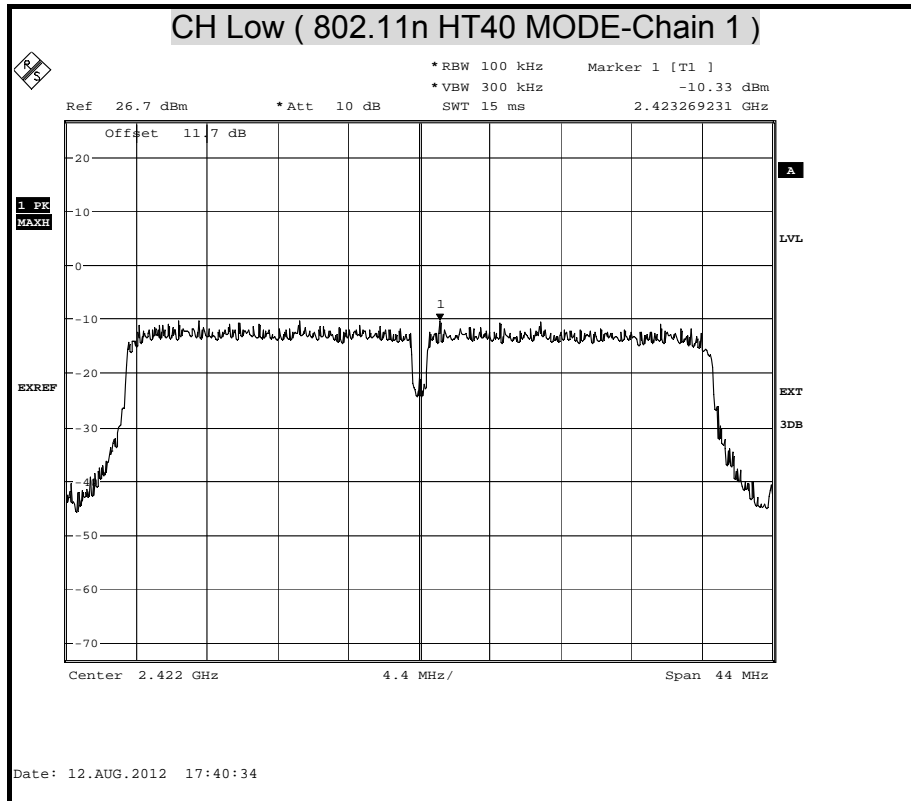

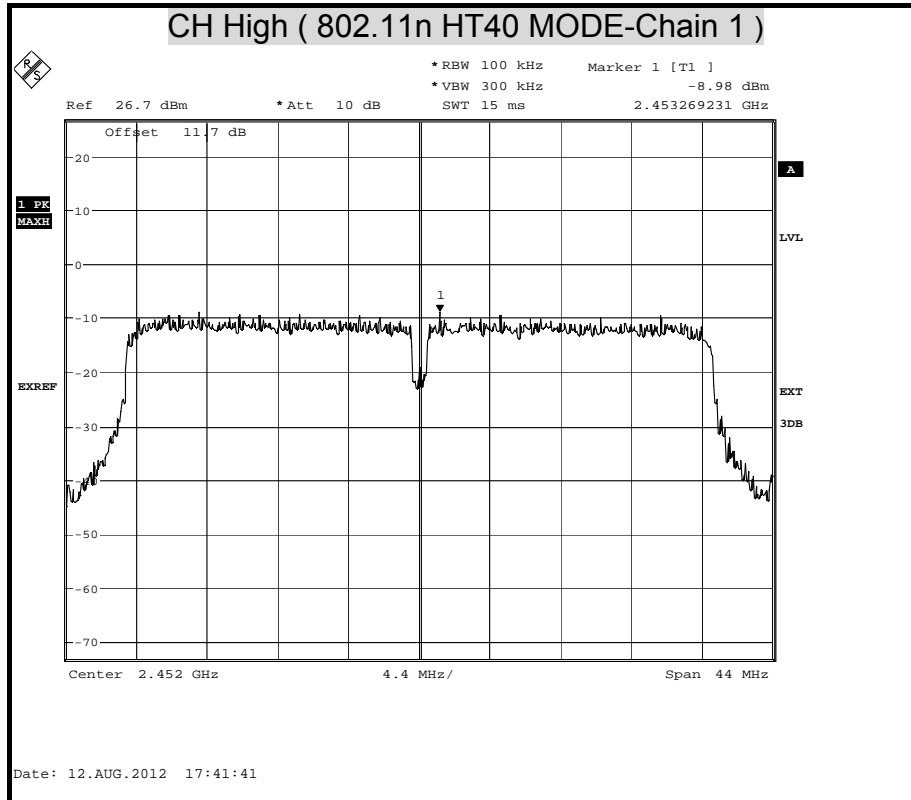



8.5 CONDUCTED SPURIOUS EMISSION

LIMITS

§ 15.247(d) In any 100 kHz bandwidth outside the frequency band in which the spread spectrum intentional radiator is operating, the radio frequency power that is produced by the intentional radiator shall be at least 20 dB below that in the 100 kHz bandwidth within the band that contains the highest level of the desired power, based on either an RF conducted or a radiated measurement. Attenuation below the general limits specified in § 15.209(a) is not required. In addition, radiated emissions which fall in the restricted bands, as defined in § 15.205(a), must also comply with the radiated emission limits specified in § 15.209(a) (see § 15.205(c)).

TEST PROCEDURE

The transmitter output is connected to a spectrum analyzer. The resolution bandwidth is set to 100 kHz. The video bandwidth is set to 100 kHz.

The spectrum from 30 MHz to 26.5 GHz is investigated with the transmitter set to the lowest, middle, and highest channels in the 2.4 GHz band.

TEST SETUP

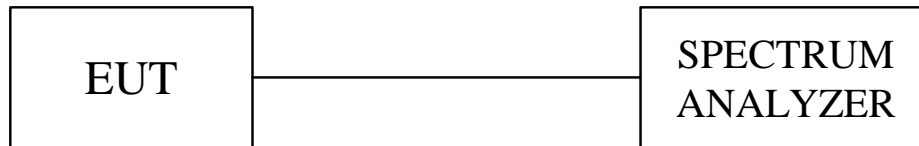

TEST RESULTS

No non-compliance noted.



OUT-OF-BAND SPURIOUS EMISSIONS-CONDUCTED MEASUREMENT (IEEE 802.11b MODE)

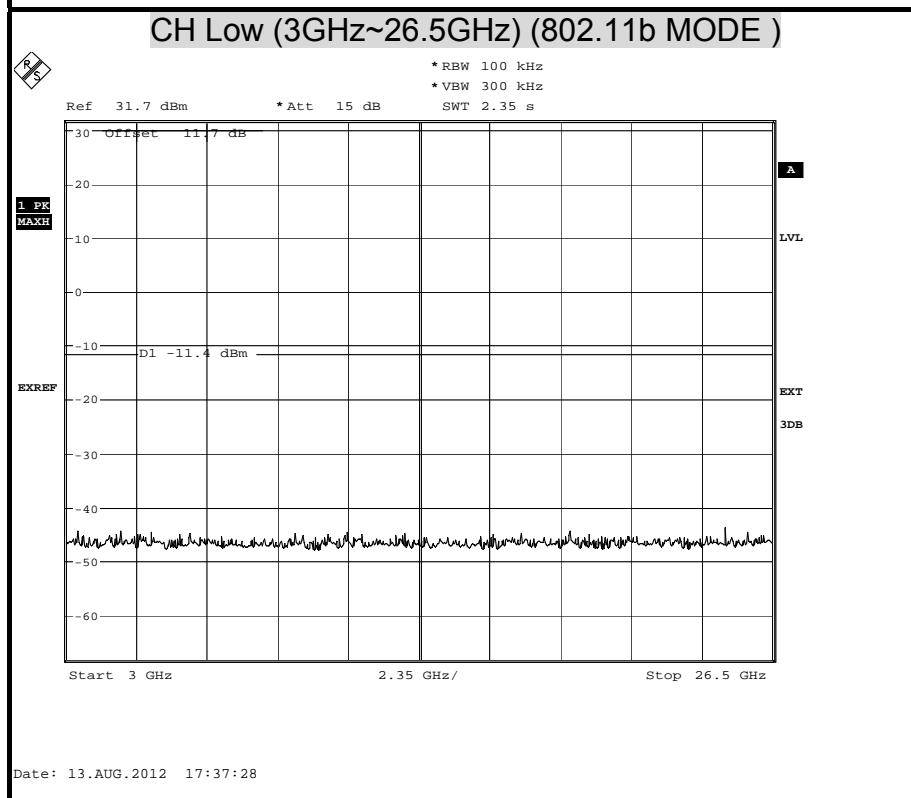
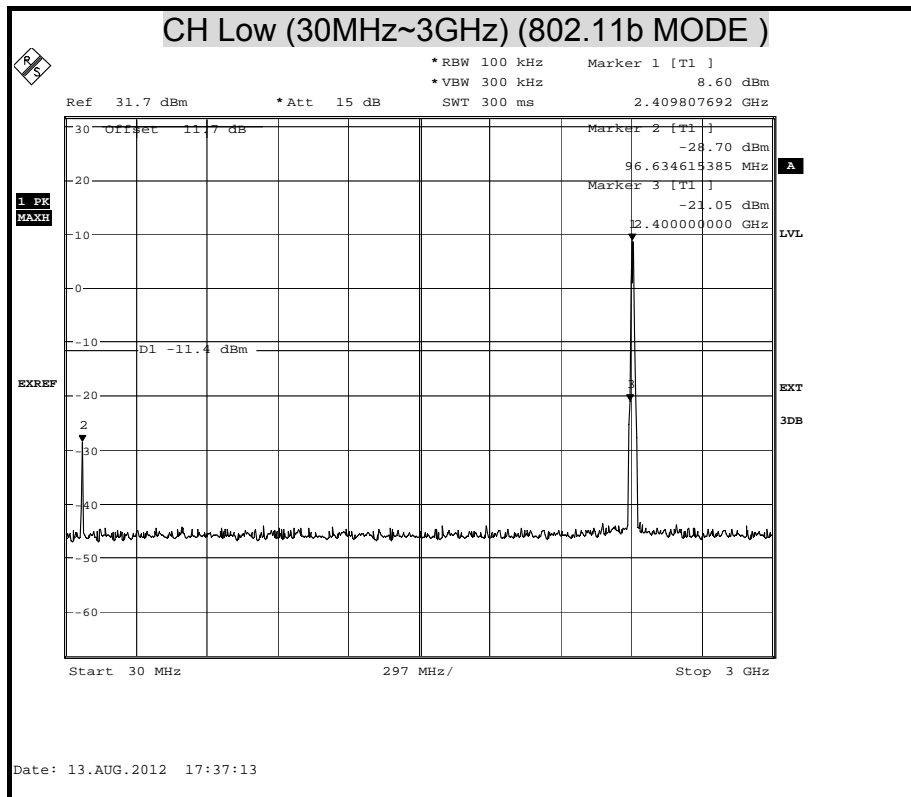

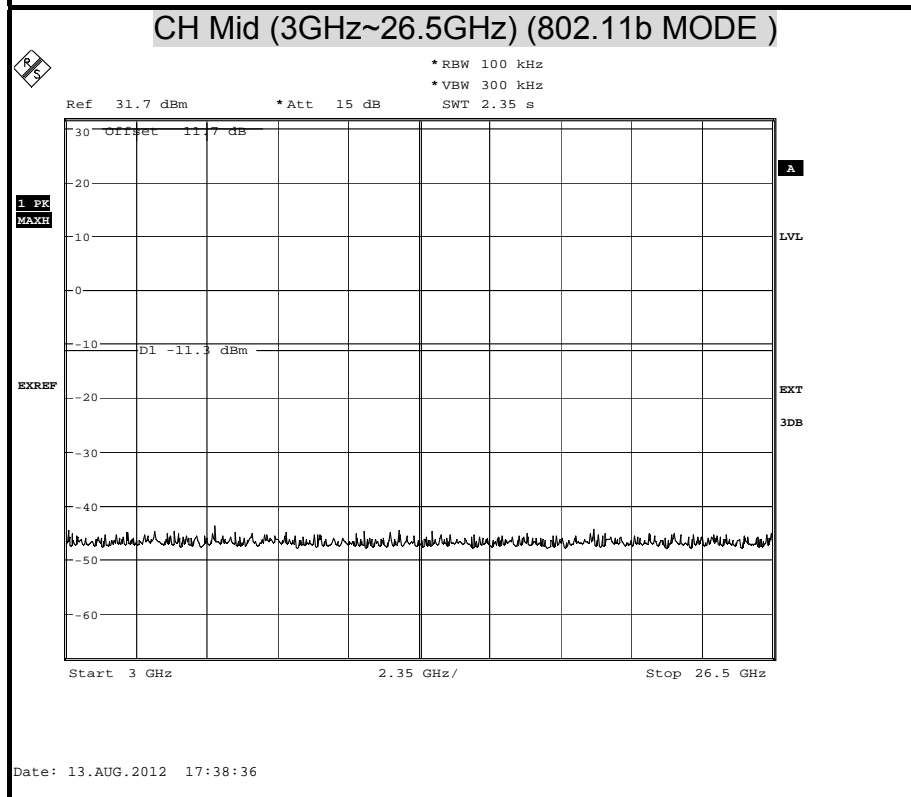
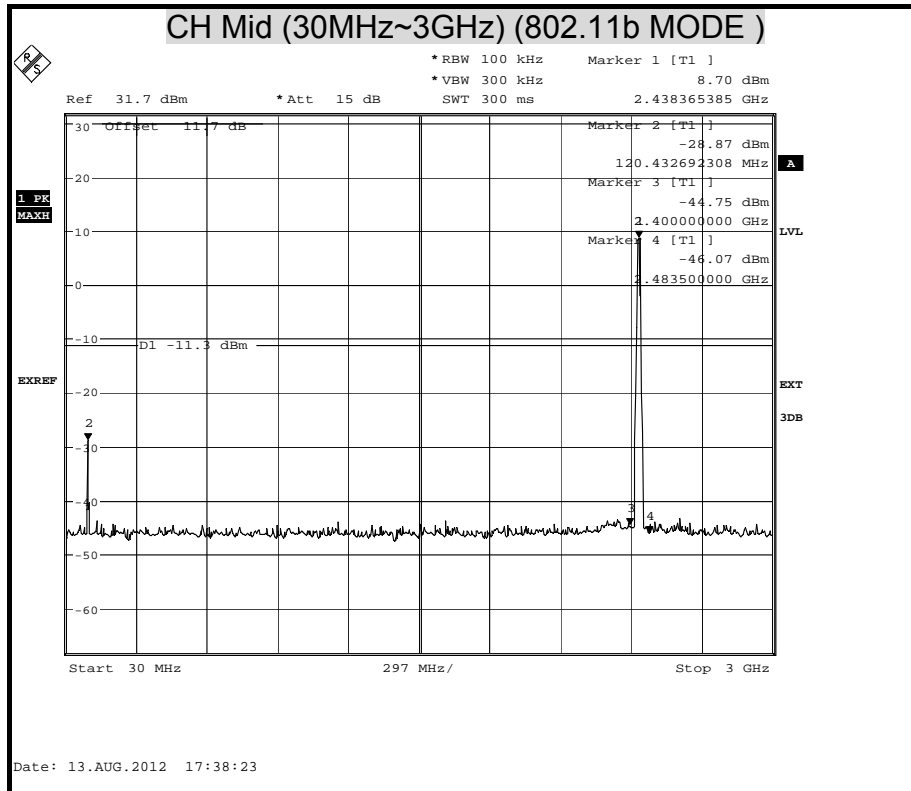

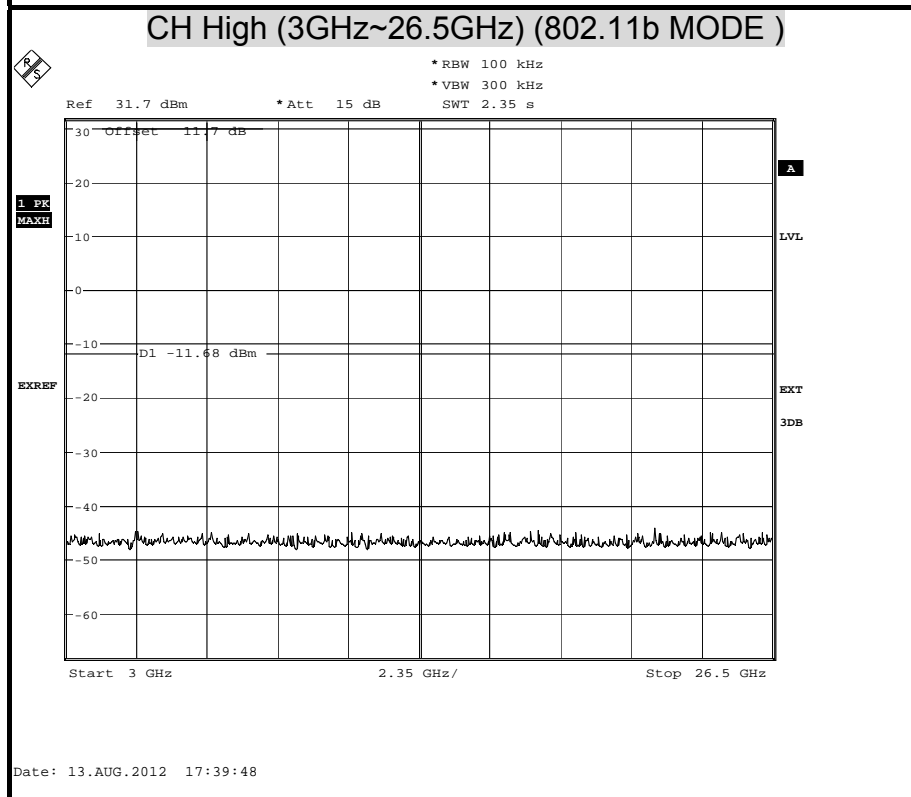
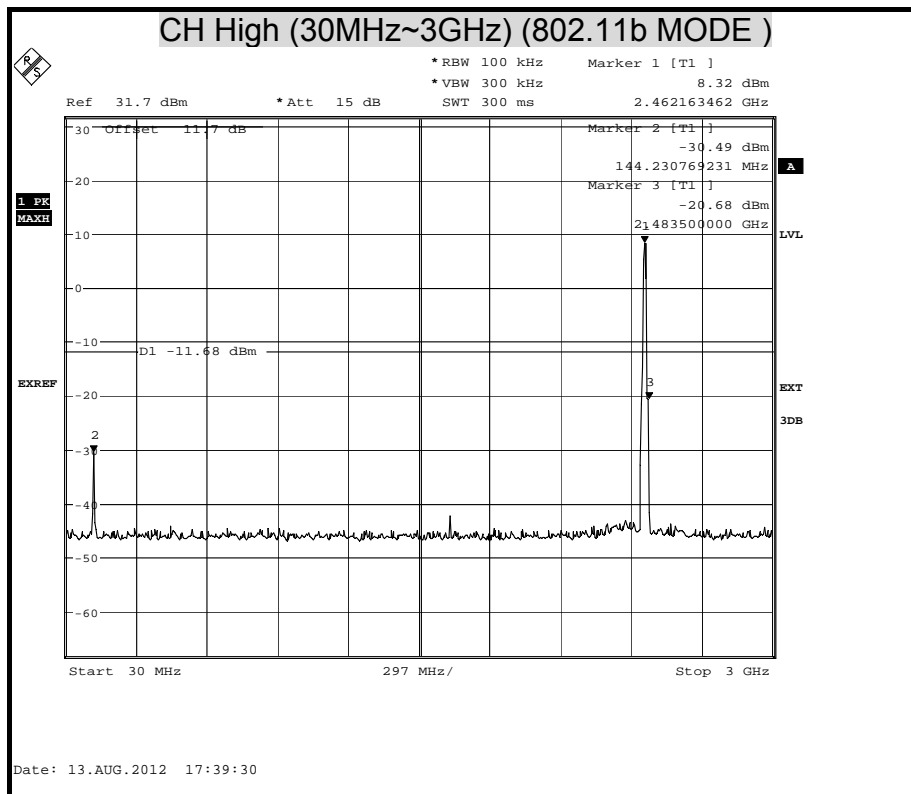



OUT-OF-BAND SPURIOUS EMISSIONS-CONDUCTED MEASUREMENT

(802.11g MODE)

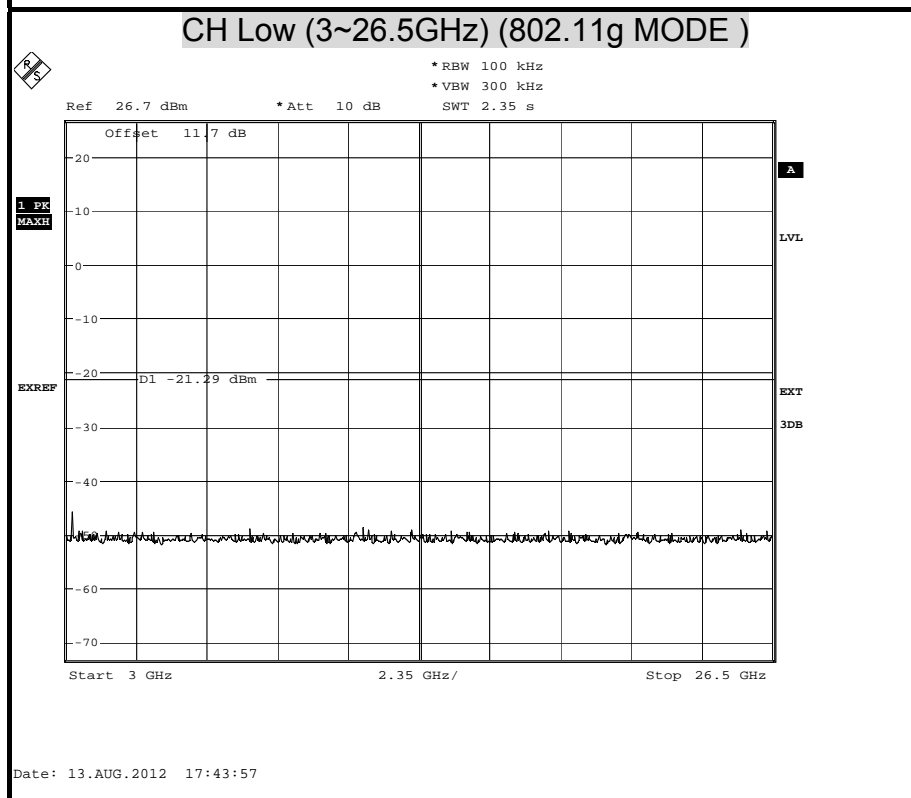
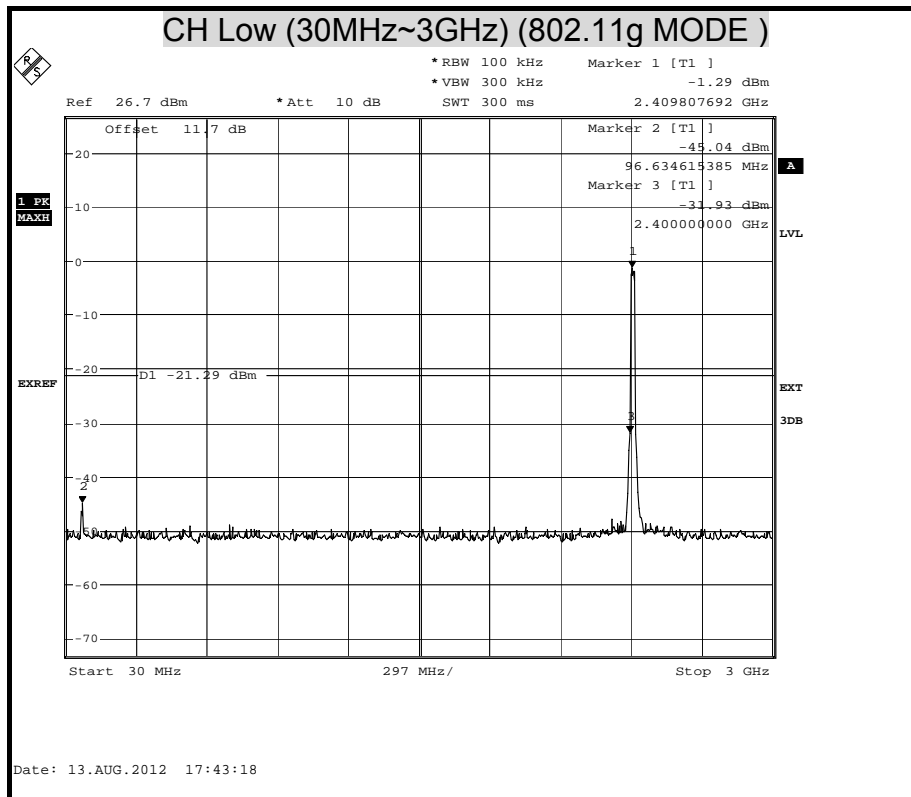

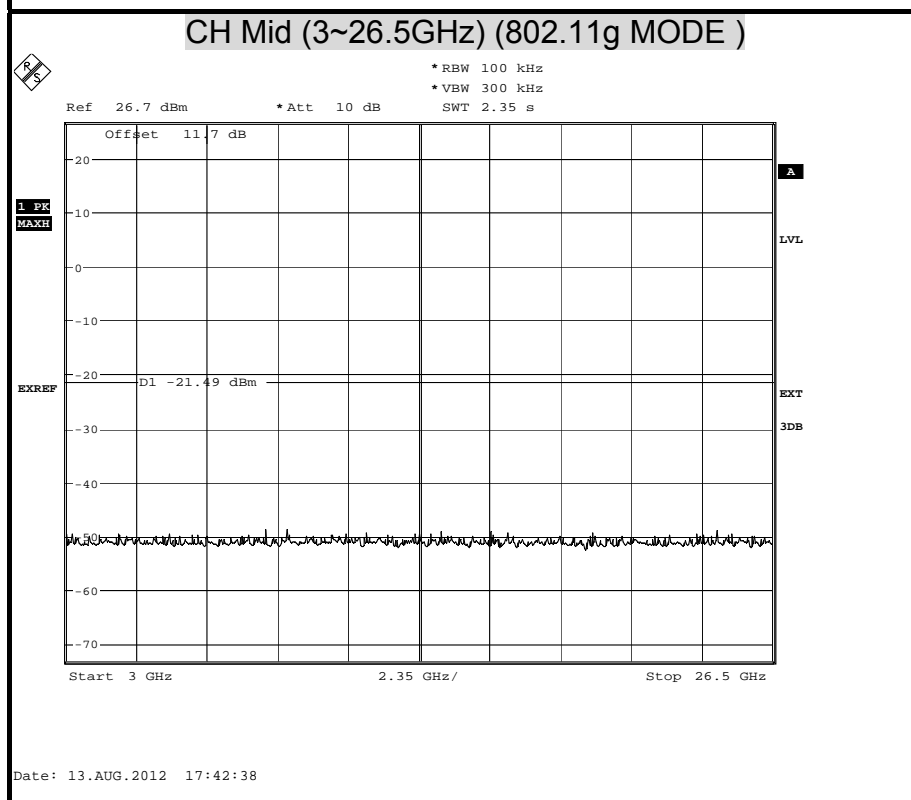
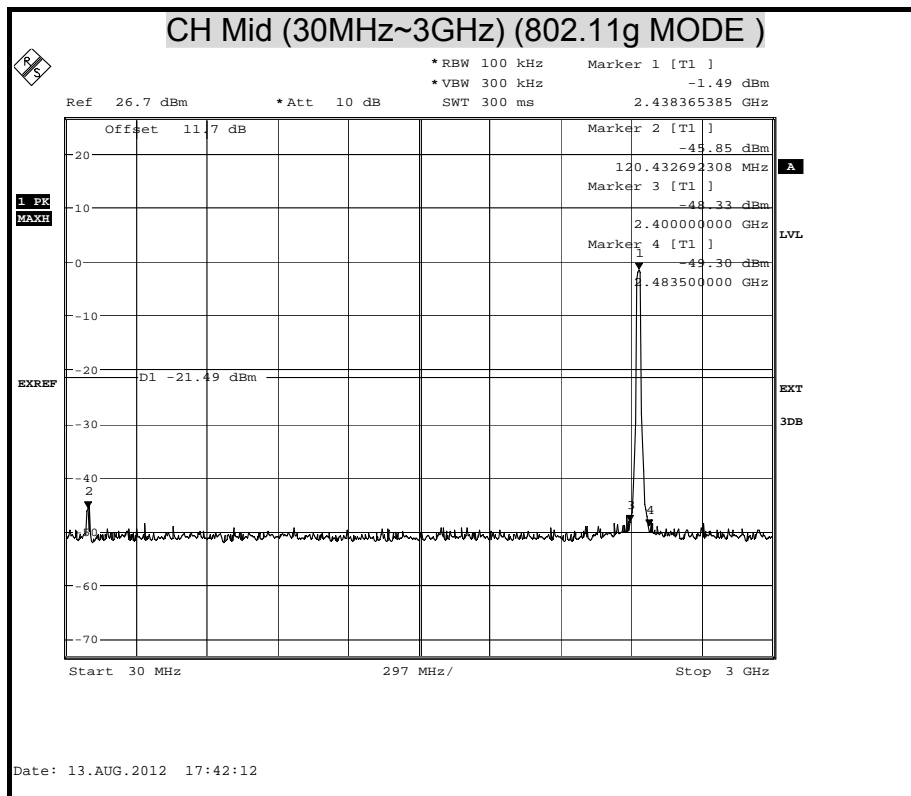

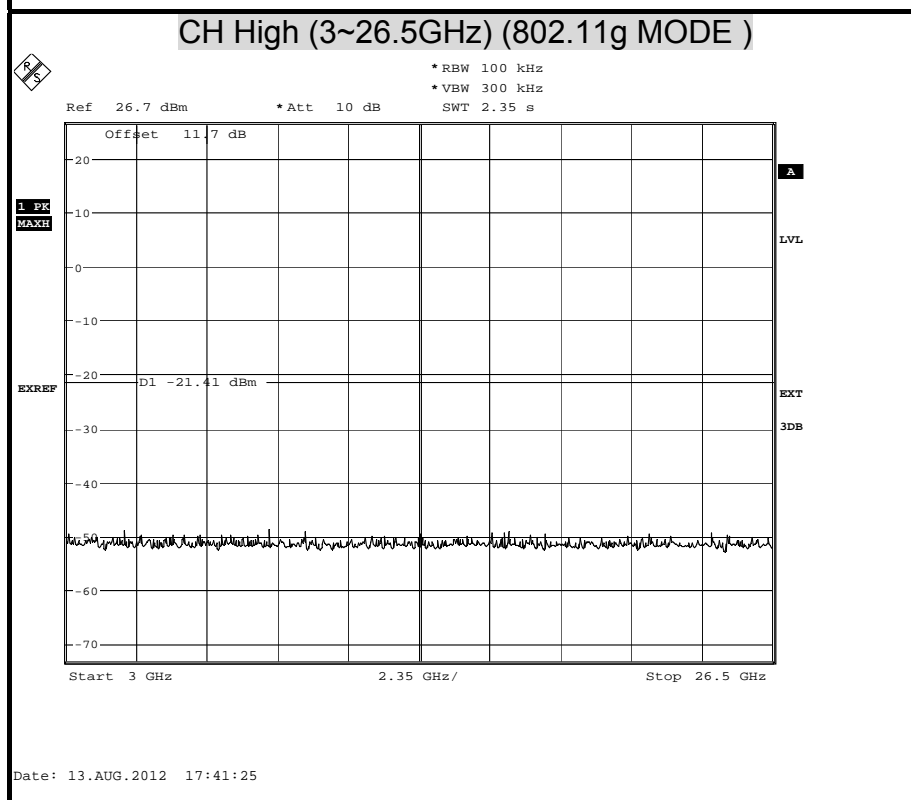
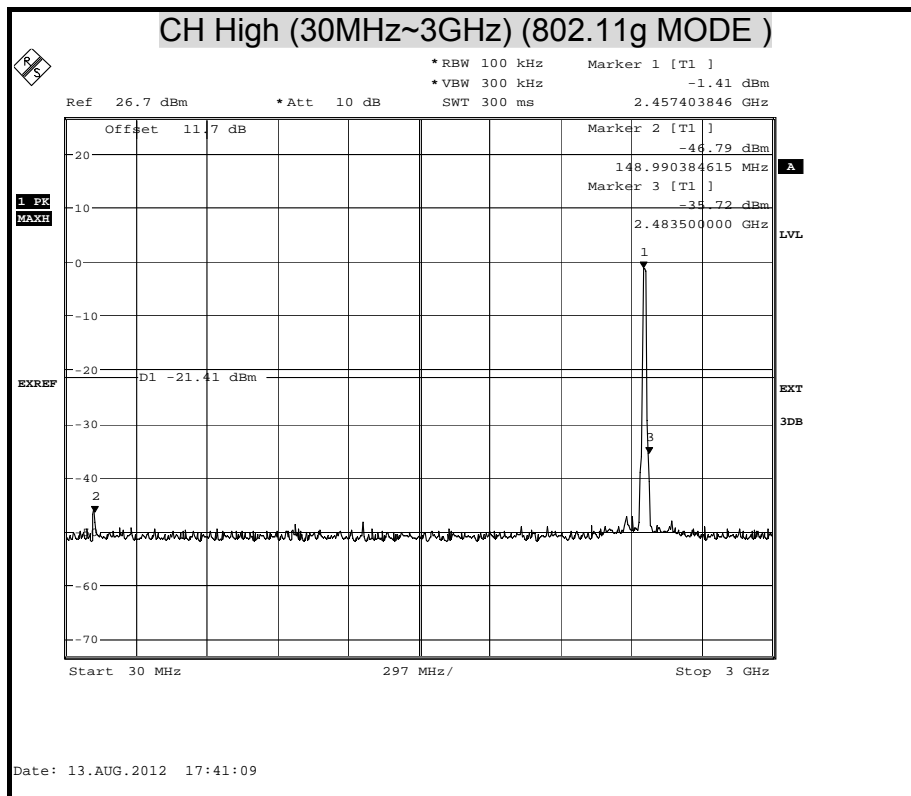



OUT-OF-BAND SPURIOUS EMISSIONS-CONDUCTED MEASUREMENT (802.11n HT20 MODE)

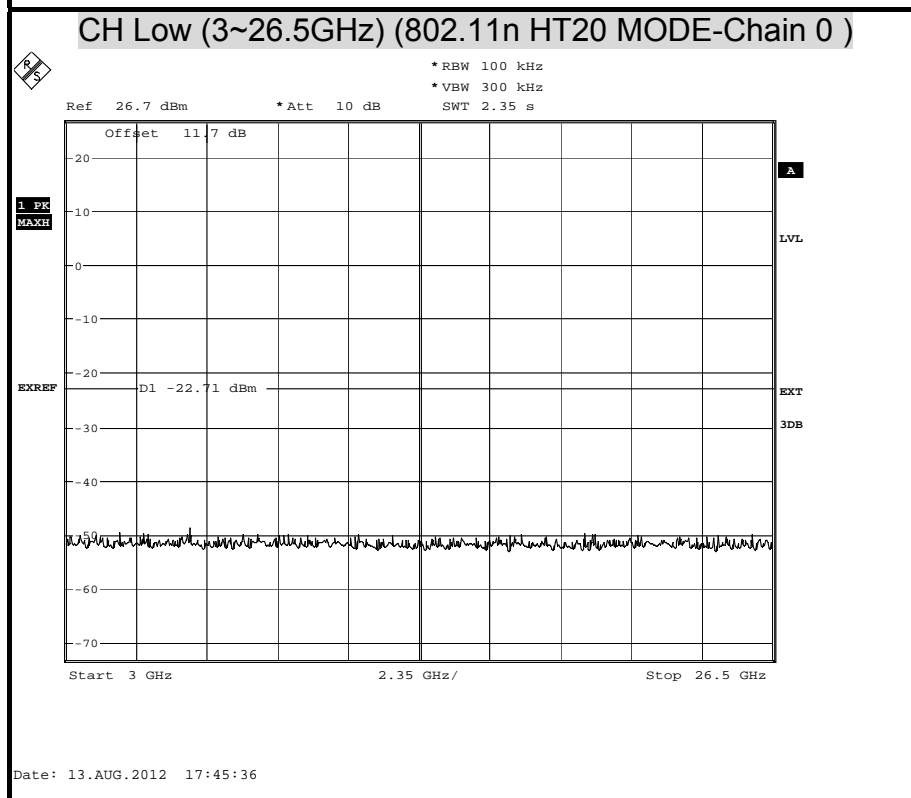
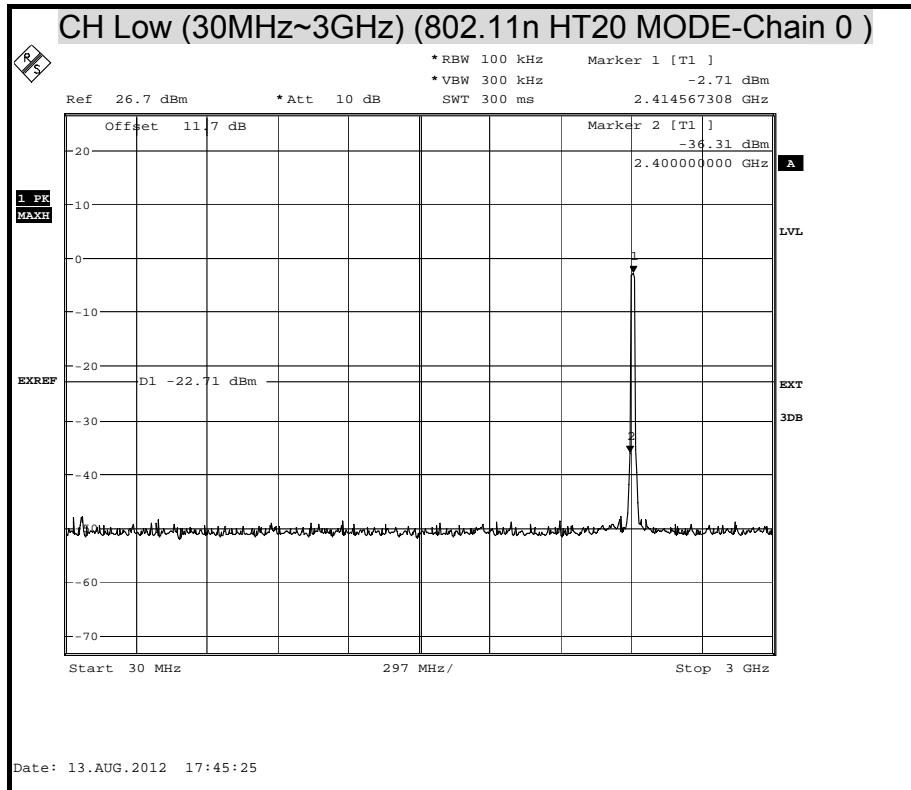

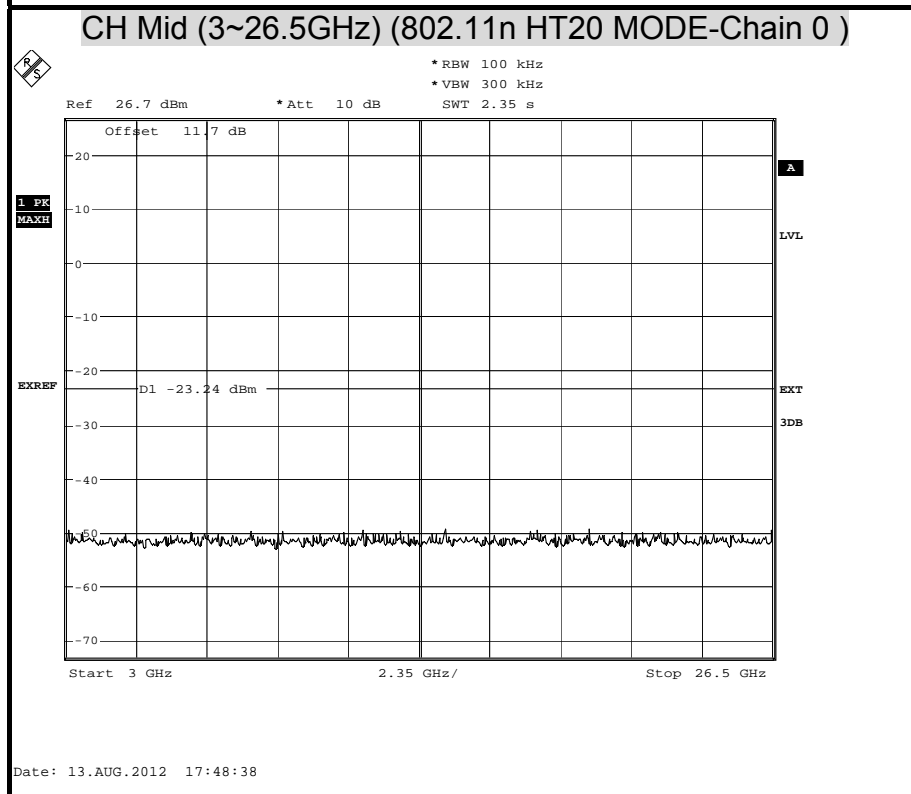
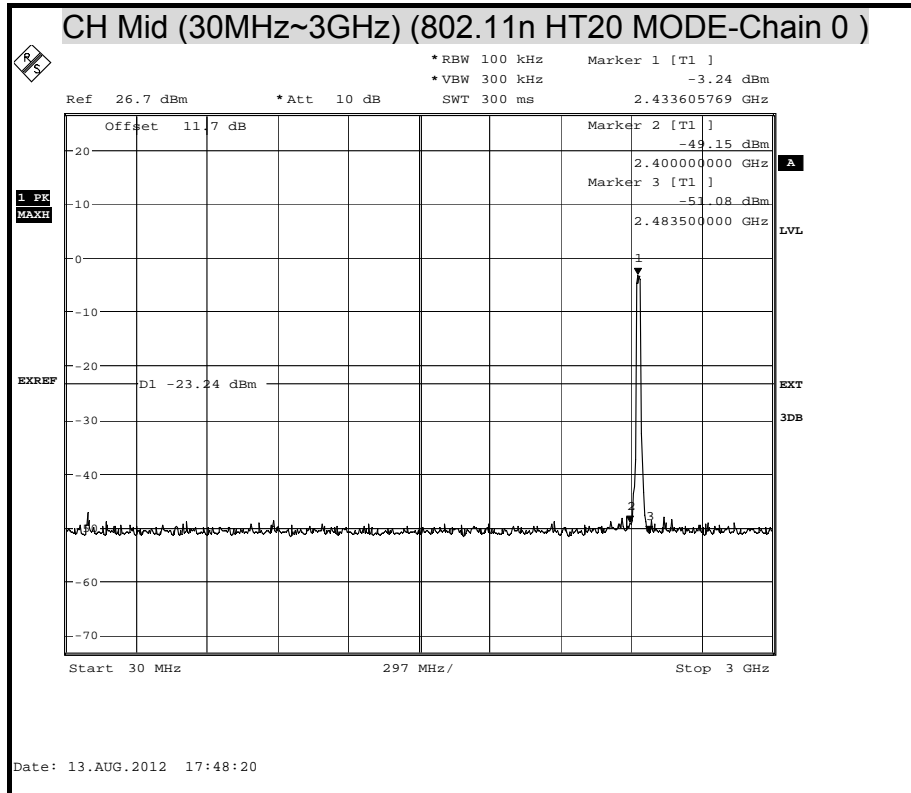

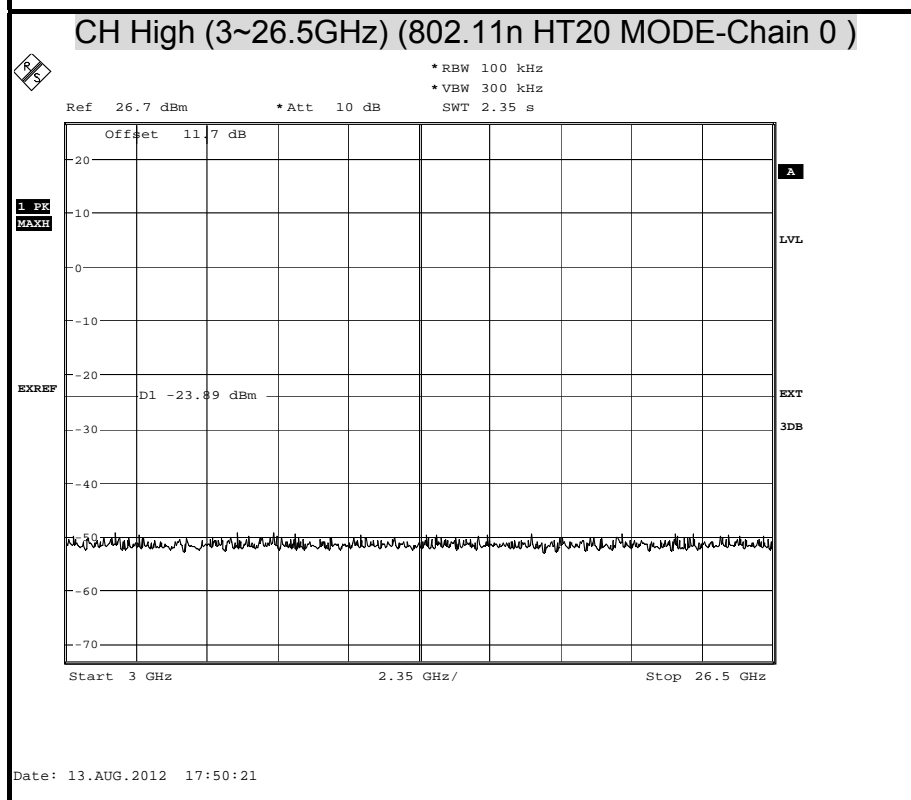
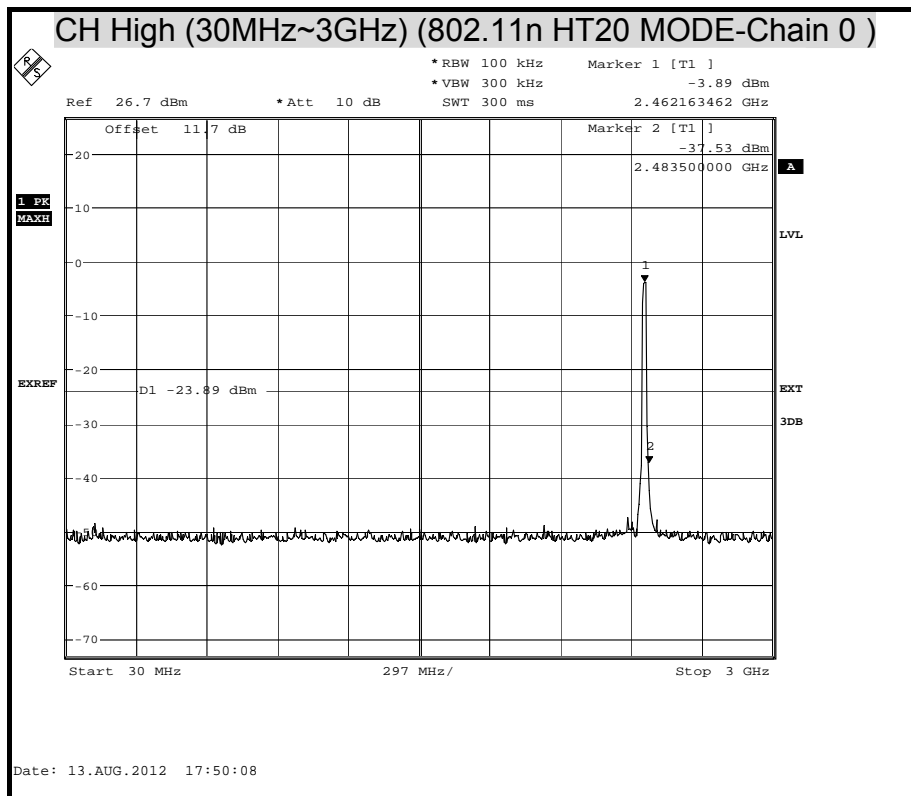

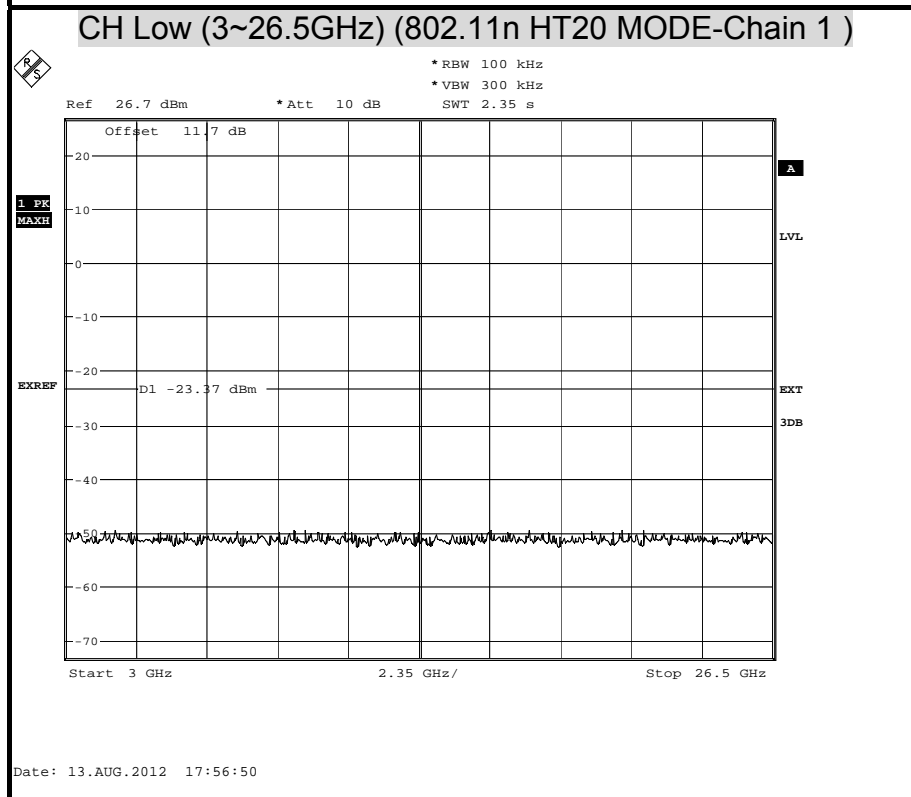
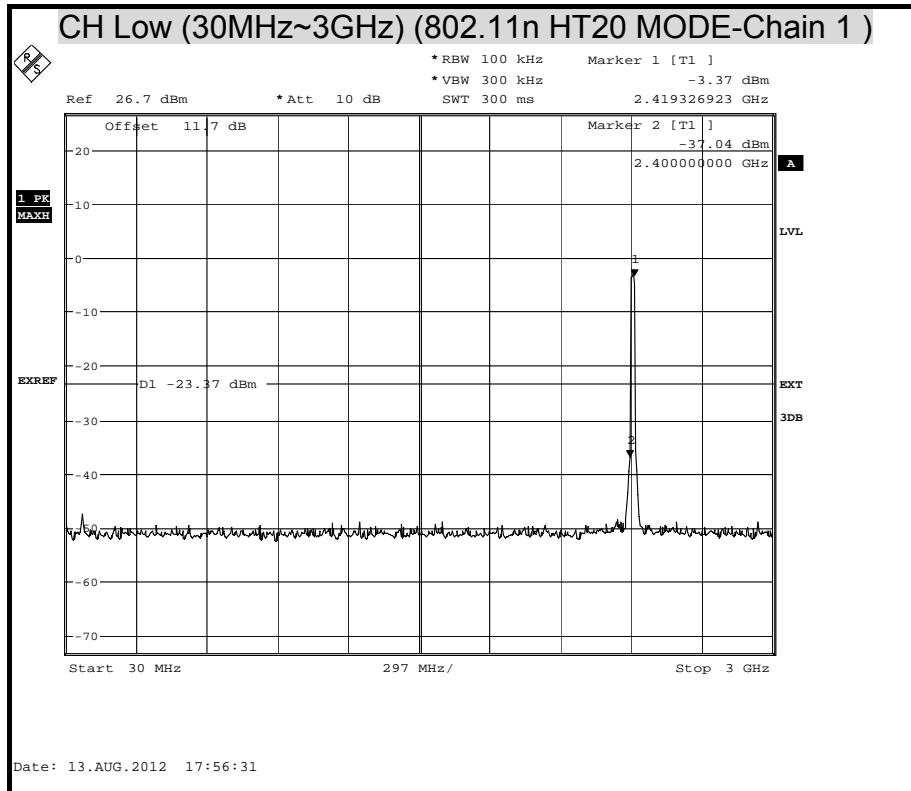

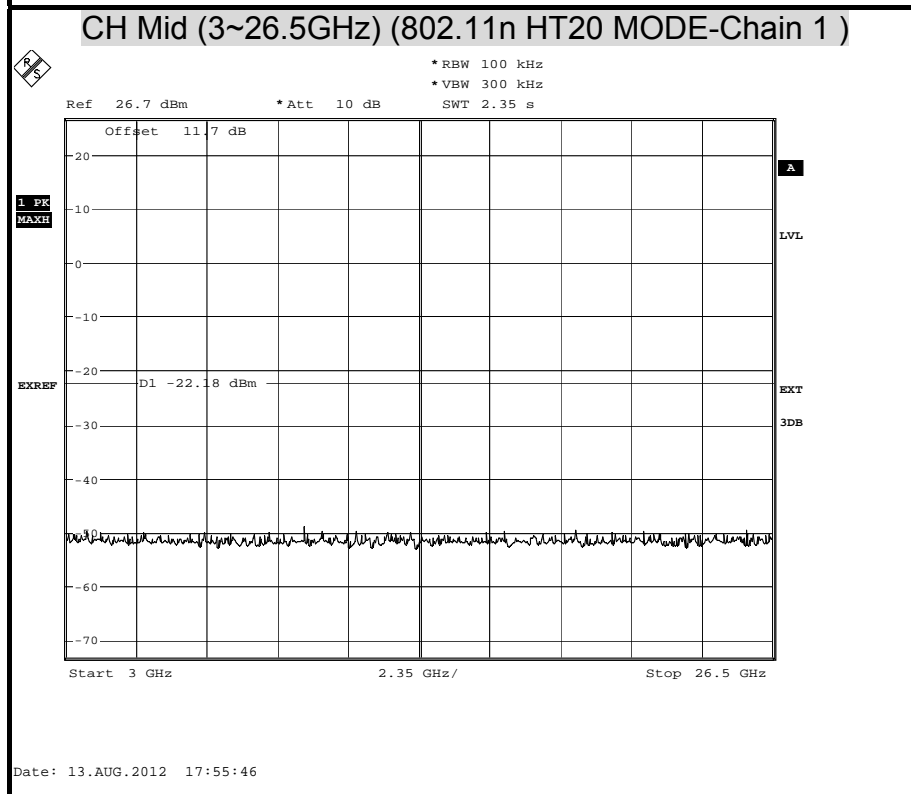
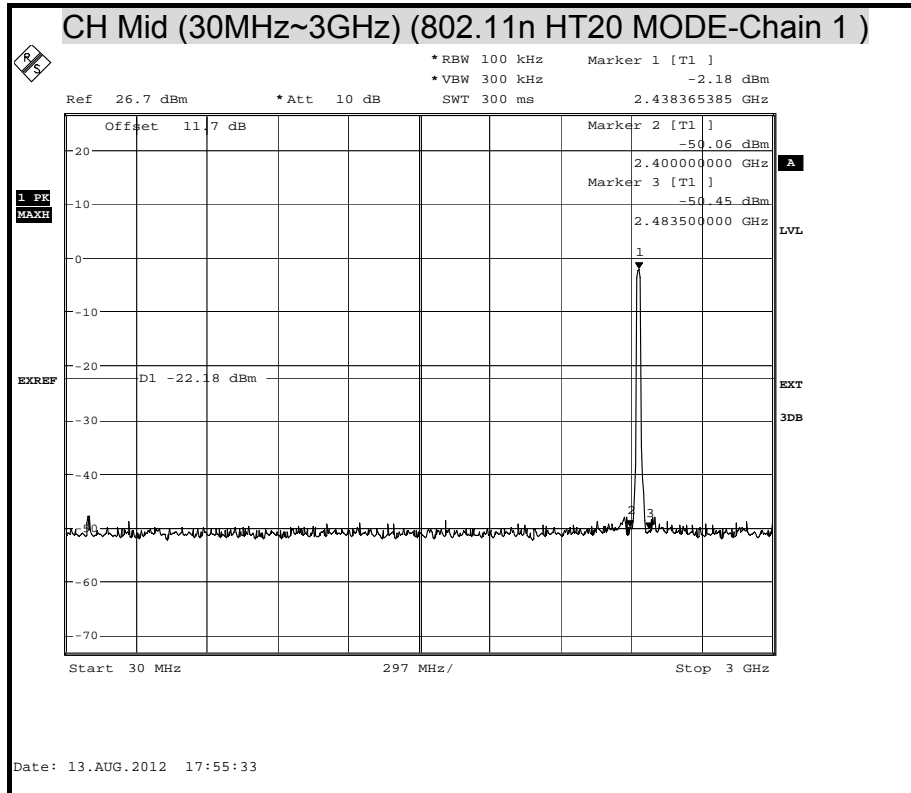

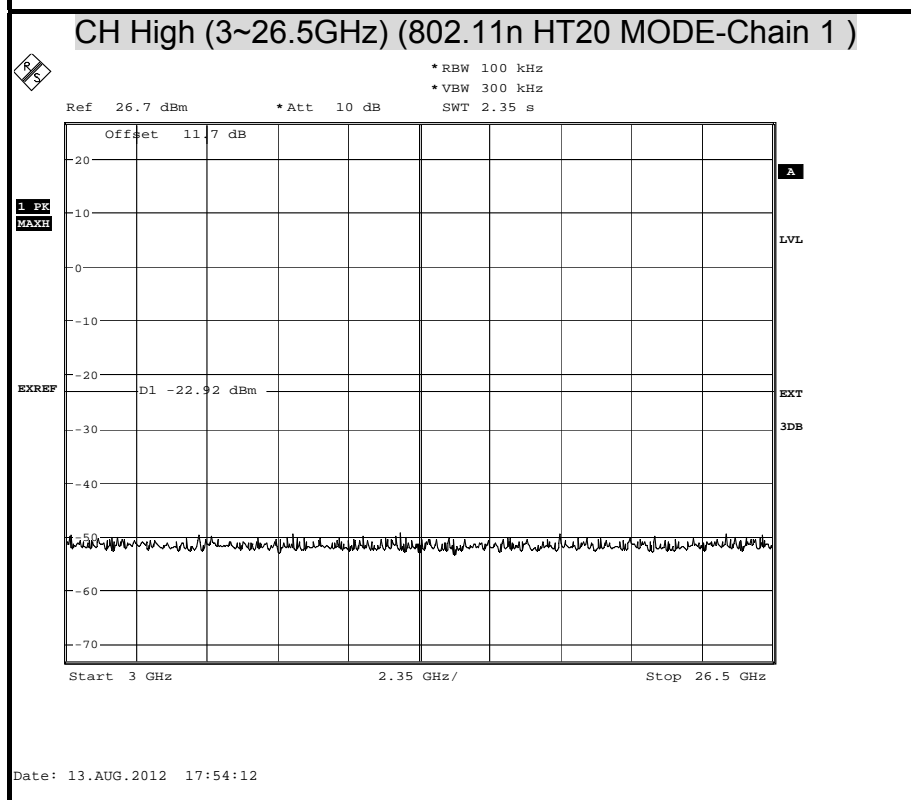
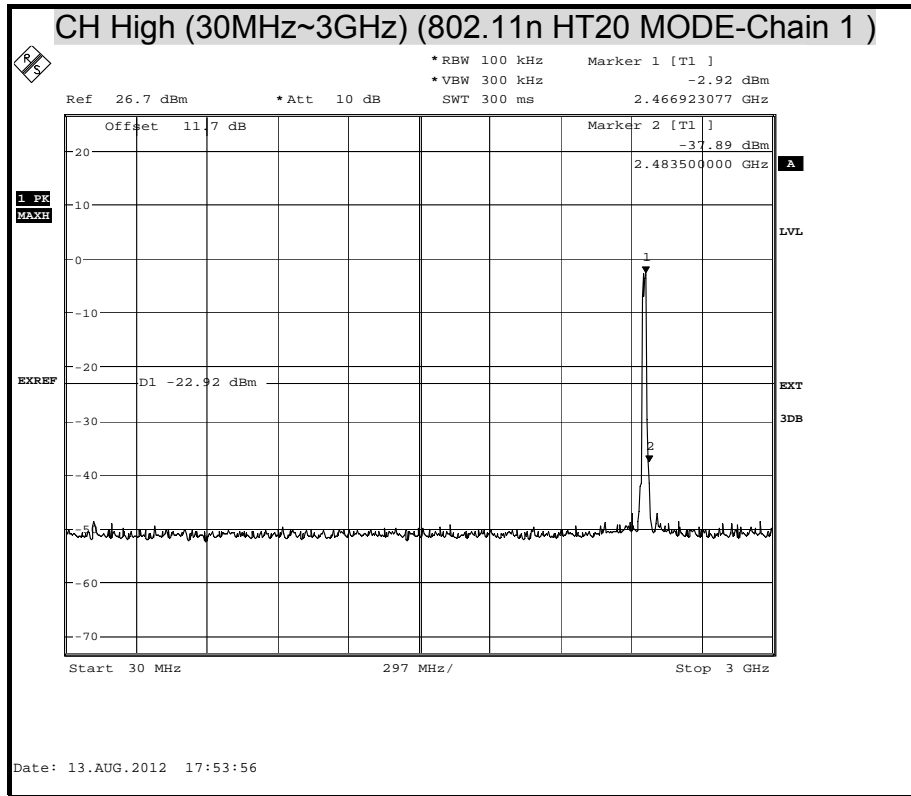



OUT-OF-BAND SPURIOUS EMISSIONS-CONDUCTED MEASUREMENT (802.11n HT40 MODE)

