



SPORTON International Inc.

No. 52, Hwa Ya 1st Rd., Hwa Ya Technology Park, Kwei-Shan Hsiang, Tao Yuan Hsien, Taiwan, R.O.C.
Ph: 886-3-327-3456 / FAX: 886-3-327-0973 / www.sporton.com.tw

FCC RADIO TEST REPORT

Applicant's company	D-Link Corporation
Applicant Address	No.289, Sinhu 3rd Rd., Neihu District, Taipei City 114, Taiwan, R.O.C.
FCC ID	KA2IR629B1

Product Name	Wireless N 450 home router
Brand Name	D-Link
Model No.	DIR-629
Test Rule	47 CFR FCC Part 15 Subpart C § 15.247
Test Freq. Range	2400 ~ 2483.5MHz
Received Date	May 29, 2015
Final Test Date	Oct. 21, 2015
Submission Type	Original Equipment

Statement

Test result included in this report is for the IEEE 802.11n and IEEE 802.11b/g of the product.

The test result in this report refers exclusively to the presented test model / sample.

Without written approval of SPORTON International Inc., the test report shall not be reproduced except in full.

The measurements and test results shown in this test report were made in accordance with the procedures and found in compliance with the limit given in **ANSI C63.10-2013, 47 CFR FCC Part 15 Subpart C, KDB558074 D01 v03r03 and KDB 662911 D01 v02r01.**

The test equipment used to perform the test is calibrated and traceable to NML/ROC.



Table of Contents

1. VERIFICATION OF COMPLIANCE	1
2. SUMMARY OF THE TEST RESULT	2
3. GENERAL INFORMATION	3
3.1. Product Details.....	3
3.2. Accessories.....	4
3.3. Table for Filed Antenna.....	5
3.4. Table for Carrier Frequencies	5
3.5. Table for Test Modes.....	6
3.6. Table for Testing Locations.....	7
3.7. Table for Supporting Units	7
3.8. Table for Parameters of Test Software Setting	8
3.9. EUT Operation during Test	8
3.10. Duty Cycle.....	8
3.11. Test Configurations	9
4. TEST RESULT	12
4.1. AC Power Line Conducted Emissions Measurement.....	12
4.2. Maximum Conducted Output Power Measurement.....	16
4.3. Power Spectral Density Measurement	18
4.4. 6dB Spectrum Bandwidth Measurement	27
4.5. Radiated Emissions Measurement	34
4.6. Emissions Measurement	52
4.7. Antenna Requirements	70
5. LIST OF MEASURING EQUIPMENTS	71
6. MEASUREMENT UNCERTAINTY	72
APPENDIX A. TEST PHOTOS	A1 ~ A5

1. VERIFICATION OF COMPLIANCE

Product Name : Wireless N 450 home router
Brand Name : D-Link
Model No. : DIR-629
Applicant : D-Link Corporation
Test Rule Part(s) : 47 CFR FCC Part 15 Subpart C § 15.247

Sporton International as requested by the applicant to evaluate the EMC performance of the product sample received on May 29, 2015 would like to declare that the tested sample has been evaluated and found to be in compliance with the tested rule parts. The data recorded as well as the test configuration specified is true and accurate for showing the sample's EMC nature.



Sam Chen

SPORTON INTERNATIONAL INC.

2. SUMMARY OF THE TEST RESULT

Applied Standard: 47 CFR FCC Part 15 Subpart C				
Part	Rule Section	Description of Test	Result	Under Limit
4.1	15.207	AC Power Line Conducted Emissions	Complies	7.84 dB
4.2	15.247(b)(3)	Maximum Conducted Output Power	Complies	0.54 dB
4.3	15.247(e)	Power Spectral Density	Complies	6.65 dB
4.4	15.247(a)(2)	6dB Spectrum Bandwidth	Complies	-
4.5	15.247(d)	Radiated Emissions	Complies	4.46 dB
4.6	15.247(d)	Band Edge Emissions	Complies	0.01 dB
4.7	15.203	Antenna Requirements	Complies	-

3. GENERAL INFORMATION

3.1. Product Details

Items	Description
Product Type	WLAN (3TX, 3RX)
Radio Type	Intentional Transceiver
Power Type	From power adapter
Modulation	IEEE 802.11b: DSSS IEEE 802.11g: OFDM IEEE 802.11n: see the below table
Data Modulation	IEEE 802.11b: DSSS (BPSK / QPSK / CCK) IEEE 802.11g/n: OFDM (BPSK / QPSK / 16QAM / 64QAM)
Data Rate (Mbps)	IEEE 802.11b: DSSS (1/ 2/ 5.5/11) IEEE 802.11g: OFDM (6/9/12/18/24/36/48/54) IEEE 802.11n: see the below table
Frequency Range	2400 ~ 2483.5MHz
Channel Number	11 for 20MHz bandwidth ; 7 for 40MHz bandwidth
Channel Band Width (99%)	IEEE 802.11b: 12.48 MHz IEEE 802.11g: 16.20 MHz IEEE 802.11n MCS0 (HT20): 17.76 MHz IEEE 802.11n MCS0 (HT40): 36.20 MHz
Maximum Conducted Output Power	IEEE 802.11b: 29.46 dBm IEEE 802.11g: 26.58 dBm IEEE 802.11n MCS0 (HT20): 26.37 dBm IEEE 802.11n MCS0 (HT40): 24.63 dBm
Carrier Frequencies	Please refer to section 3.4
Antenna	Please refer to section 3.3

Antenna and Band width

Antenna	Three (TX)	
Band width Mode	20 MHz	40 MHz
IEEE 802.11b	V	X
IEEE 802.11g	V	X
IEEE 802.11n	V	V

IEEE 11n Spec.

Protocol	Number of Transmit Chains (NTX)	Data Rate / MCS
802.11n (HT20)	3	MCS 0-23
802.11n (HT40)	3	MCS 0-23

Note 1: IEEE Std. 802.11n modulation consists of HT20 and HT40 (HT: High Throughput).
Then EUT supports HT20 and HT40.

Note 2: Modulation modes consist of below configuration: HT20/HT40: IEEE 802.11n

3.2. Accessories

Power	Brand	Model	Rating
Adapter 1	AMIGO	AMS135-1201000FU	Input: 100-240V~50/60Hz, 0.5A/27VA Output: 12V, 1.0A
Adapter 2	LEI	MU12AR120100-A1	Input: 100-240V~50/60Hz, 0.3A Output: 12V, 1A

3.3. Table for Filed Antenna

Ant.	Brand	Model Name	Antenna Type	Connector	Gain (dBi)
1	Hong-Lin	290-20203	Dipole Antenna	N/A	5
2	Hong-Lin	290-20204	Dipole Antenna	N/A	5
3	Hong-Lin	290-20203	Dipole Antenna	N/A	5

Note: The EUT has three antennas.

For IEEE 802.11b/g/n mode (3TX/3RX):

Chain 1, Chain 2 and Chain 3 could transmit/receive simultaneously.

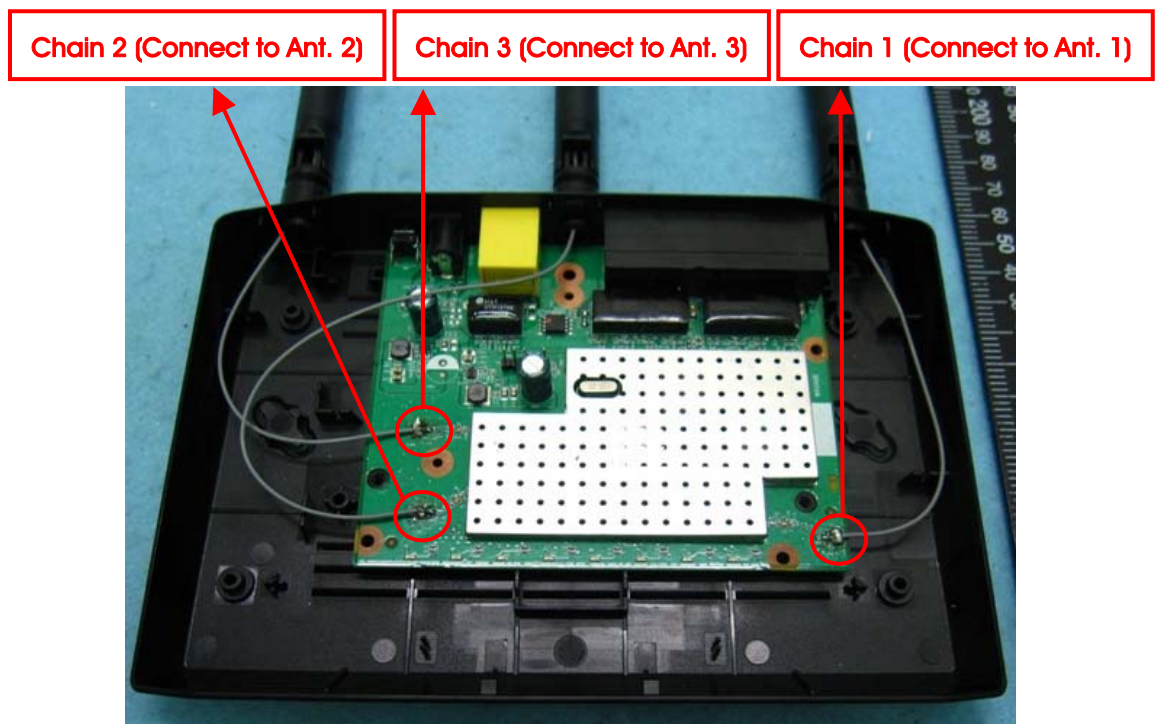

3.4. Table for Carrier Frequencies

There are two bandwidth systems.

For 20MHz bandwidth systems, use Channel 1~Channel 11.

For 40MHz bandwidth systems, use Channel 3~Channel 9.

Frequency Band	Channel No.	Frequency	Channel No.	Frequency
2400~2483.5MHz	1	2412 MHz	7	2442 MHz
	2	2417 MHz	8	2447 MHz
	3	2422 MHz	9	2452 MHz
	4	2427 MHz	10	2457 MHz
	5	2432 MHz	11	2462 MHz
	6	2437 MHz	-	-

3.5. Table for Test Modes

Preliminary tests were performed in different data rate to find the worst radiated emission. The data rate shown in the table below is the worst-case rate with respect to the specific test item. Investigation has been done on all the possible configurations for searching the worst cases. The following table is a list of the test modes shown in this test report.

Test Items	Mode	Data Rate	Channel	Chain
AC Power Line Conducted Emissions	Normal Link	-	-	-
Maximum Conducted Output Power	11b/CCK	1 Mbps	1/6/11	1+2+3
	11g/BPSK	6 Mbps	1/6/11	1+2+3
	11n HT20	MCS0	1/6/11	1+2+3
	11n HT40	MCS0	3/6/9	1+2+3
Power Spectral Density	11b/CCK	1 Mbps	1/6/11	1+2+3
	11g/BPSK	6 Mbps	1/6/11	1+2+3
	11n HT20	MCS0	1/6/11	1+2+3
	11n HT40	MCS0	3/6/9	1+2+3
6dB Spectrum Bandwidth	11b/CCK	1 Mbps	1/6/11	1+2+3
	11g/BPSK	6 Mbps	1/6/11	1+2+3
	11n HT20	MCS0	1/6/11	1+2+3
	11n HT40	MCS0	3/6/9	1+2+3
Radiated Emissions 9kHz~1GHz	Normal Link	-	-	-
Radiated Emissions 1GHz~10 th Harmonic	11b/CCK	1 Mbps	1/6/11	1+2+3
	11g/BPSK	6 Mbps	1/6/11	1+2+3
	11n HT20	MCS0	1/6/11	1+2+3
	11n HT40	MCS0	3/6/9	1+2+3
Band Edge Emissions	11b/CCK	1 Mbps	1/6/11	1+2+3
	11g/BPSK	6 Mbps	1/6/11	1+2+3
	11n HT20	MCS0	1/6/11	1+2+3
	11n HT40	MCS0	3/6/9	1+2+3

The following test modes were performed for all tests:

For Conducted Emission test:

Mode 1. Normal Link-Place EUT in Z axis + Adapter 1

Mode 2. Normal Link-Place EUT in Z axis + Adapter 2

Mode 1 generated the worst test result, so it was recorded in this report.

For Radiated Emission test (Below 1GHz):

Mode 1. Normal Link-Place EUT in Z axis + Adapter 1

Mode 2. Normal Link-Place EUT in Z axis + Adapter 2

Mode 1 generated the worst test result, so it was recorded in this report.

For Radiated Emission test (Above 1GHz):

Mode 1. CTX-Place EUT in Z axis + Adapter 1

Note: The EUT can only be used at Z axis position.

3.6. Table for Testing Locations

Test Site Location				
Address:	No.8, Lane 724, Bo-ai St., Jhubei City, Hsinchu County 302, Taiwan, R.O.C.			
TEL:	886-3-656-9065			
FAX:	886-3-656-9085			
Test Site No.	Site Category	Location	FCC Reg. No.	IC File No.
03CH01-CB	SAC	Hsin Chu	262045	IC 4086D
CO01-CB	Conduction	Hsin Chu	262045	IC 4086D
TH01-CB	OVEN Room	Hsin Chu	-	-

Open Area Test Site (OATS); Semi Anechoic Chamber (SAC).

3.7. Table for Supporting Units

For Test Site No: CO01-CB

Support Unit	Brand	Model	FCC ID
Notebook*3	DELL	E6430	DoC

For Test Site No: 03CH01-CB (Below 1GHz)

Support Unit	Brand	Model	FCC ID
Notebook*3	DELL	E4300	DoC

For Test Site No: 03CH01-CB (Above 1GHz)

Support Unit	Brand	Model	FCC ID
Notebook	DELL	E4300	DoC

For Test Site No: TH01-CB

Support Unit	Brand	Model	FCC ID
Notebook	DELL	E4300	DoC

3.8. Table for Parameters of Test Software Setting

During testing, Channel and Power Controlling Software provided by the customer was used to control the operating channel as well as the output power level. The RF output power selection is for the setting of RF output power expected by the customer and is going to be fixed on the firmware of the final end product.

Test Software Version	DOS					
Mode	Test Frequency (MHz)					
	NCB: 20MHz			NCB: 40MHz		
	2412 MHz	2437 MHz	2462 MHz	2422 MHz	2437 MHz	2452 MHz
802.11b	19	20	19.5	-	-	-
802.11g	15.5	17	15.5	-	-	-
802.11n MCS0 HT20	14.5	17	15	-	-	-
802.11n MCS0 HT40	-	-	-	12	15	13.5

3.9. EUT Operation during Test

The EUT was programmed to be in continuously transmitting mode.

3.10. Duty Cycle

Mode	On Time (ms)	On+Off Time (ms)	Duty Cycle (%)	Duty Factor (dB)	1/T Minimum VBW (kHz)
802.11b	1.000	1.000	100.00	0.00	0.01
802.11g	2.028	2.074	97.78	0.10	0.49
802.11n MCS0 HT20	1.882	1.934	97.31	0.12	0.53
802.11n MCS0 HT40	0.912	0.960	95.00	0.22	1.10

3.11. Test Configurations

3.11.1. AC Power Line Conduction Emissions Test Configuration

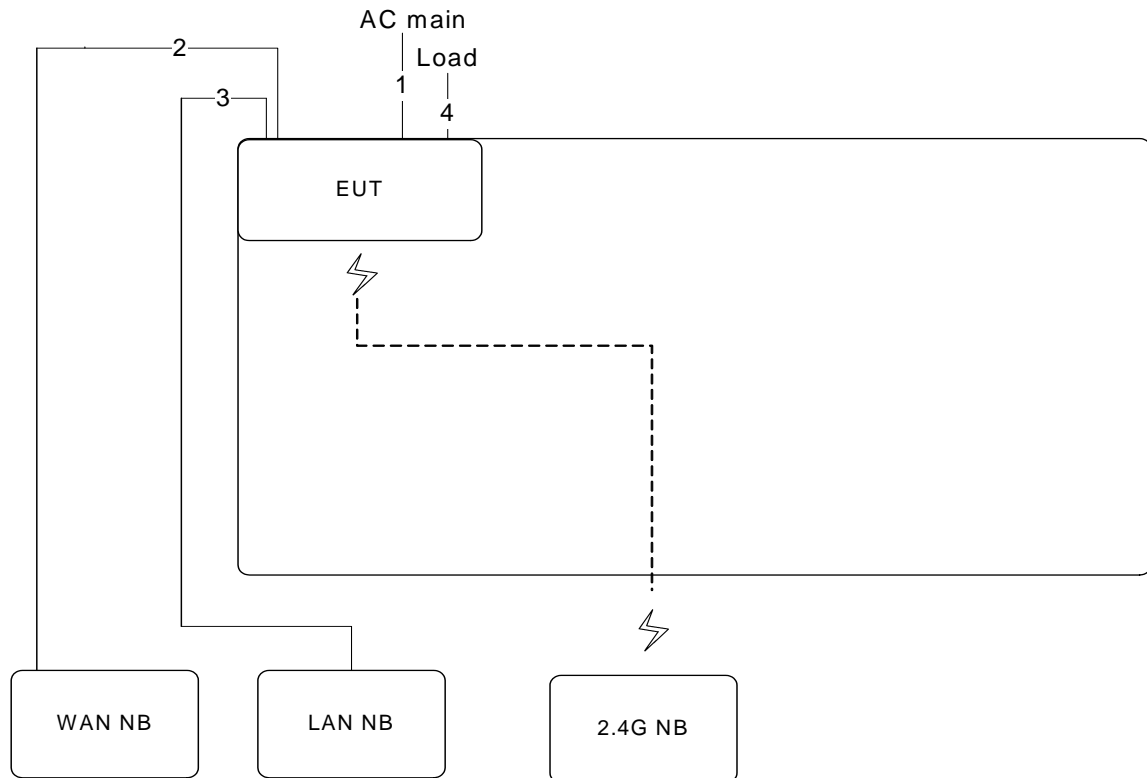

Item	Connection	Shielded	Length
1	Power cable	No	1.2m
2	RJ-45 cable	No	10m
3	RJ-45 cable	No	10m
4	RJ-45 cable*3	No	3m

3.11.2. Radiation Emissions Test Configuration

Test Configuration: 30MHz~1GHz

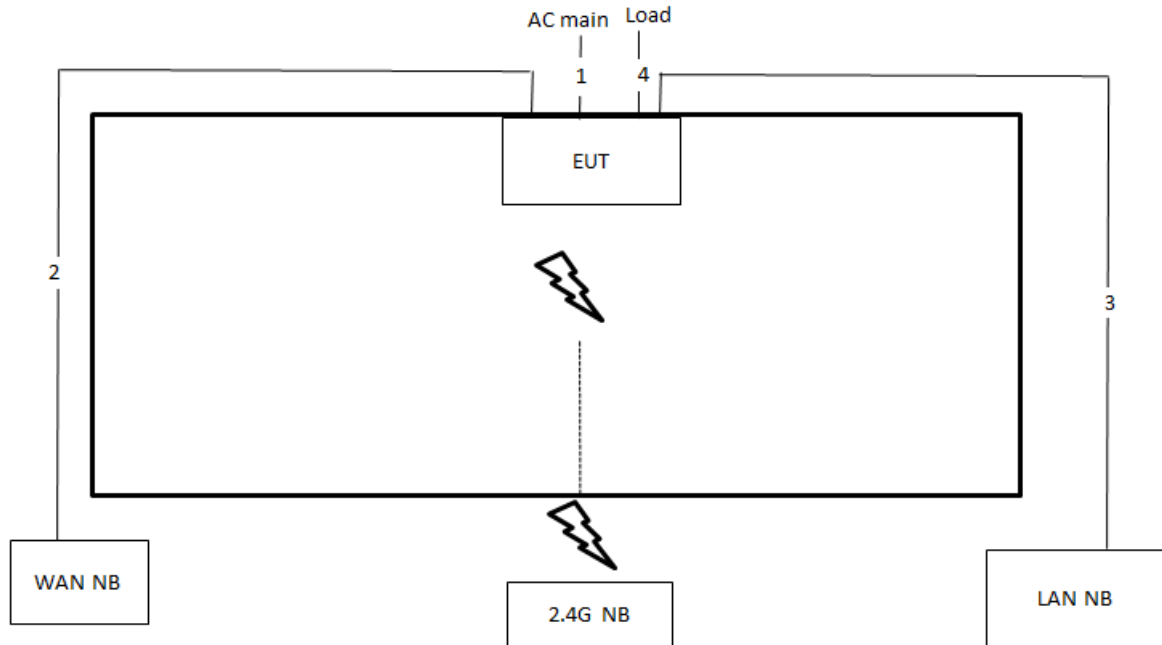

Item	Connection	Shielded	Length
1	Power cable	No	1.2m
2	RJ-45 cable	No	10m
3	RJ-45 cable	No	10m
4	RJ45 cable*3	No	3m

Test Configuration: above 1GHz

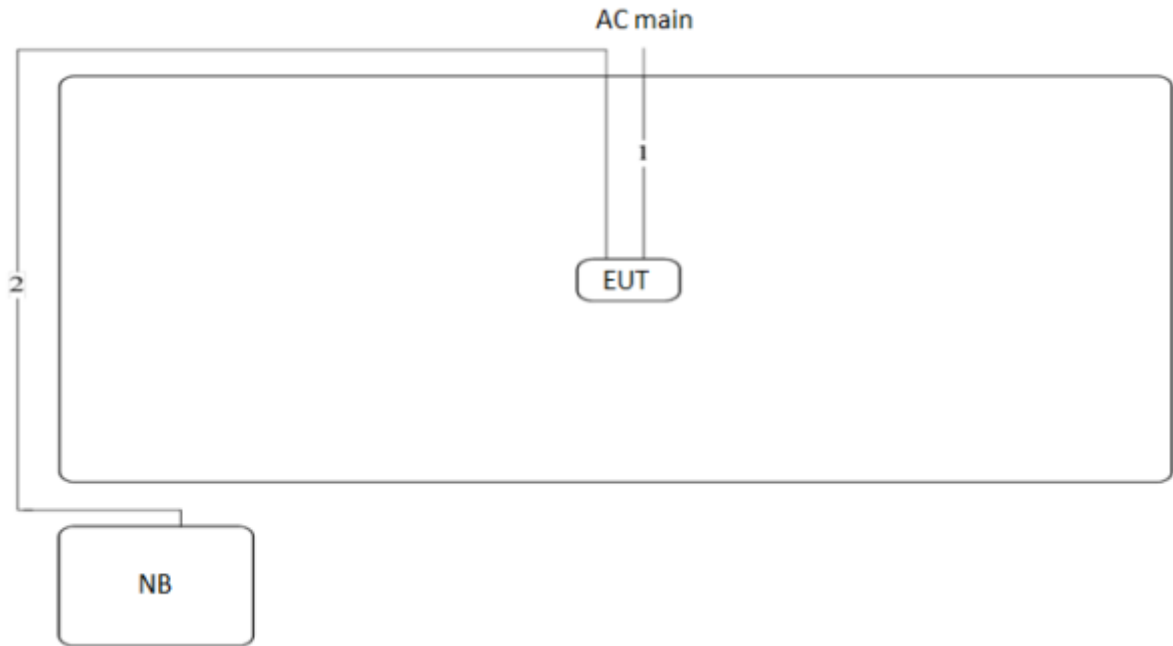

Item	Connection	Shielded	Length
1	Power cable	No	1.2m
2	RJ-45 cable	No	10m

4. TEST RESULT

4.1. AC Power Line Conducted Emissions Measurement

4.1.1. Limit

For this product which is designed to be connected to the AC power line, the radio frequency voltage that is conducted back onto the AC power line on any frequency or frequencies within the band 150 kHz to 30 MHz shall not exceed below limits table.

Frequency (MHz)	QP Limit (dBuV)	AV Limit (dBuV)
0.15~0.5	66~56	56~46
0.5~5	56	46
5~30	60	50

4.1.2. Measuring Instruments and Setting

Please refer to section 5 of equipments list in this report. The following table is the setting of the receiver.

Receiver Parameters	Setting
Attenuation	10 dB
Start Frequency	0.15 MHz
Stop Frequency	30 MHz
IF Bandwidth	9 kHz

4.1.3. Test Procedures

1. Configure the EUT according to ANSI C63.10. The EUT or host of EUT has to be placed 0.4 meter far from the conducting wall of the shielding room and at least 80 centimeters from any other grounded conducting surface.
2. Connect EUT or host of EUT to the power mains through a line impedance stabilization network (LISN).
3. All the support units are connected to the other LISNs. The LISN should provide 50uH/50ohms coupling impedance.
4. The frequency range from 150 kHz to 30 MHz was searched.
5. Set the test-receiver system to Peak Detect Function and Specified Bandwidth with Maximum Hold Mode.
6. The measurement has to be done between each power line and ground at the power terminal.

4.1.7. Results of AC Power Line Conducted Emissions Measurement

Temperature	25°C	Humidity	58%
Test Engineer	Parody Lin	Phase	Line
Configuration	Normal Link		

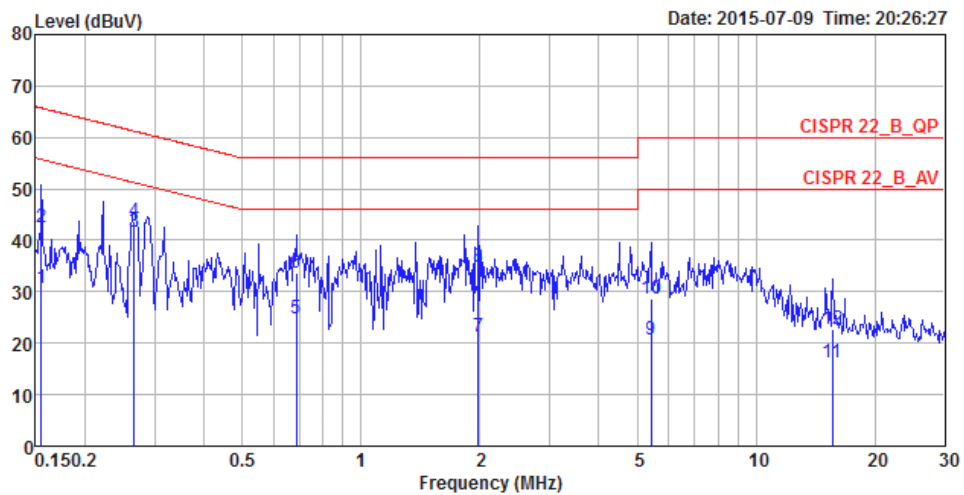

	Freq	Level	Over Limit	Limit Line	Read Level	LISN Factor	Cable Loss	Pol/Phase	Remark
	MHz	dBuV	dB	dBuV	dBuV	dB	dB		
1	0.1548	30.71	-25.03	55.74	20.76	9.93	0.02	LINE	Average
2	0.1548	42.59	-23.15	65.74	32.64	9.93	0.02	LINE	QP
3	0.2658	41.70	-9.55	51.25	31.74	9.93	0.03	LINE	Average
4	0.2658	43.57	-17.68	61.25	33.61	9.93	0.03	LINE	QP
5	0.6863	24.67	-21.33	46.00	14.68	9.95	0.04	LINE	Average
6	0.6863	33.78	-22.22	56.00	23.79	9.95	0.04	LINE	QP
7	1.9801	21.13	-24.87	46.00	11.08	9.99	0.06	LINE	Average
8	1.9801	34.78	-21.22	56.00	24.73	9.99	0.06	LINE	QP
9	5.4186	20.71	-29.29	50.00	10.53	10.07	0.11	LINE	Average
10	5.4186	28.63	-31.37	60.00	18.45	10.07	0.11	LINE	QP
11	15.6349	16.30	-33.70	50.00	5.69	10.35	0.26	LINE	Average
12	15.6349	22.60	-37.40	60.00	11.99	10.35	0.26	LINE	QP

Temperature	25°C	Humidity	58%
Test Engineer	Parody Lin	Phase	Neutral
Configuration	Normal Link		

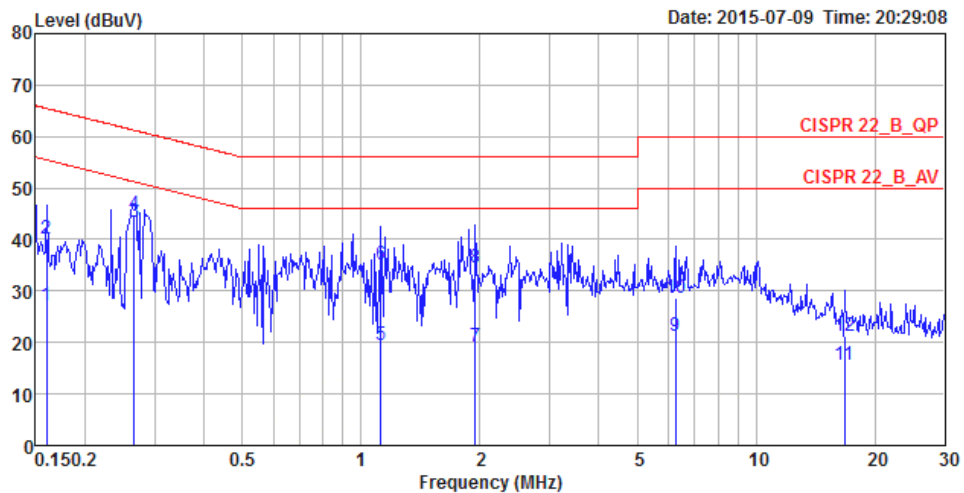

	Freq	Level	Over Limit	Limit Line	Read Level	LISN Factor	Cable Loss	Pol/Phase	Remark
	MHz	dBuV	dB	dBuV	dBuV	dB	dB		
1	0.1598	27.09	-28.38	55.47	17.29	9.78	0.02	NEUTRAL	Average
2	0.1598	40.13	-25.34	65.47	30.33	9.78	0.02	NEUTRAL	QP
3	0.2658	43.41	-7.84	51.25	33.59	9.79	0.03	NEUTRAL	Average
4	0.2658	44.72	-16.53	61.25	34.90	9.79	0.03	NEUTRAL	QP
5	1.1233	19.59	-26.41	46.00	9.73	9.81	0.05	NEUTRAL	Average
6	1.1233	35.11	-20.89	56.00	25.25	9.81	0.05	NEUTRAL	QP
7	1.9489	19.07	-26.93	46.00	9.17	9.84	0.06	NEUTRAL	Average
8	1.9489	34.46	-21.54	56.00	24.56	9.84	0.06	NEUTRAL	QP
9	6.2520	21.34	-28.66	50.00	11.27	9.94	0.13	NEUTRAL	Average
10	6.2520	28.59	-31.41	60.00	18.52	9.94	0.13	NEUTRAL	QP
11	16.7497	15.56	-34.44	50.00	5.16	10.14	0.26	NEUTRAL	Average
12	16.7497	21.40	-38.60	60.00	11.00	10.14	0.26	NEUTRAL	QP

Note:

Level = Read Level + LISN Factor + Cable Loss.

4.2. Maximum Conducted Output Power Measurement

4.2.1. Limit

The limit for output power is 30dBm.

4.2.2. Measuring Instruments and Setting

Please refer to section 5 of equipments list in this report. The following table is the setting of the power meter.

Power Meter Parameter	Setting
Bandwidth	50MHz bandwidth is greater than the EUT emission bandwidth
Detector	Average

4.2.3. Test Procedures

1. Test procedures refer KDB558074 D01 v03r03 section 9.2.3.2 Measurement using a power meter (PM).
2. Multiple antenna systems was performed in accordance with KDB 662911 D01 v02r01 Emissions Testing of Transmitters with Multiple Outputs in the Same Band.
3. This procedure provides an alternative for determining the RMS output power using a broadband RF average power meter with a thermocouple detector.

4.2.4. Test Setup Layout

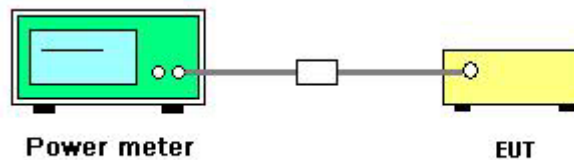

4.2.5. Test Deviation

There is no deviation with the original standard.

4.2.6. EUT Operation during Test

The EUT was programmed to be in continuously transmitting mode.

4.2.7. Test Result of Maximum Conducted Output Power

Temperature	24°C	Humidity	51%
Test Engineer	Kenneth Huang	Test Date	Oct. 14, 2015

Mode	Frequency	Conducted Power (dBm)				Max. Limit (dBm)	Result
		Chain 1	Chain 2	Chain 3	Total		
802.11b	2412 MHz	23.72	23.32	23.77	28.38	30.00	Complies
	2437 MHz	25.15	24.33	24.53	29.46	30.00	Complies
	2462 MHz	24.55	24.14	24.09	29.04	30.00	Complies
802.11g	2412 MHz	20.55	19.76	20.26	24.97	30.00	Complies
	2437 MHz	22.43	21.56	21.35	26.58	30.00	Complies
	2462 MHz	20.52	20.08	20.31	25.08	30.00	Complies
802.11n MCS0 HT20	2412 MHz	19.25	18.64	18.94	23.72	30.00	Complies
	2437 MHz	22.12	21.30	21.33	26.37	30.00	Complies
	2462 MHz	19.95	19.22	19.43	24.32	30.00	Complies
802.11n MCS0 HT40	2422 MHz	17.15	16.48	16.92	21.63	30.00	Complies
	2437 MHz	20.13	19.61	19.81	24.63	30.00	Complies
	2452 MHz	18.98	17.97	18.18	23.17	30.00	Complies

4.3. Power Spectral Density Measurement

4.3.1. Limit

For digitally modulated systems, the power spectral density conducted from the intentional radiator to the antenna shall not be greater than 8 dBm in any 3 kHz band during any time interval of continuous transmission.

4.3.2. Measuring Instruments and Setting

Please refer to section 5 of equipments list in this report. The following table is the setting of the spectrum analyzer.

Spectrum Parameter	Setting
Attenuation	Auto
Span Frequency	Set the span to 1.5 times the DTS channel bandwidth.
RBW	$3 \text{ kHz} \leq \text{RBW} \leq 100\text{kHz}$
VBW	$\geq 3 \times \text{RBW}$
Detector	Peak
Trace	Max Hold
Sweep Time	Auto couple

4.3.3. Test Procedures

1. Test was performed in accordance with KDB558074 D01 v03r03 for Performing Compliance Measurements on Digital Transmission Systems (DTS) - section 10.2 Method PKPSD (peak PSD) and KDB 662911 D01 v02r01 section In-Band Power Spectral Density (PSD) Measurements option (b) Measure and sum spectral maximal across the outputs.
2. Use this procedure when the maximum conducted output power in the fundamental emission is used to demonstrate compliance. The EUT must be configured to transmit continuously at full power over the measurement duration.
3. Ensure that the number of measurement points in the sweep $\geq 2 \times \text{span}/\text{RBW}$ (use of a greater number of measurement points than this minimum requirement is recommended).
4. Use the peak marker function to determine the maximum level in any 3 kHz band segment within the fundamental EBW.
5. The resulting PSD level must be $\leq 8 \text{ dBm}$.

4.3.4. Test Setup Layout

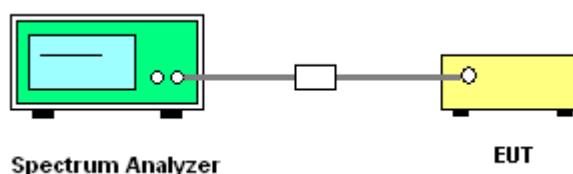

4.3.5. Test Deviation

There is no deviation with the original standard.

4.3.6. EUT Operation during Test

The EUT was programmed to be in continuously transmitting mode.

4.3.7. Test Result of Power Spectral Density

Temperature	24°C	Humidity	51%
Test Engineer	Kenneth Huang		

Mode	Frequency	Power Density (dBm/3kHz)				Power Density Limit (dBm/3kHz)	Result
		Chain 1	Chain 2	Chain 3	Total		
802.11b	2412 MHz	-7.79	-8.68	-8.08	-3.40	4.23	Complies
	2437 MHz	-7.18	-7.20	-7.18	-2.42	4.23	Complies
	2462 MHz	-7.56	-6.77	-7.30	-2.43	4.23	Complies
802.11g	2412 MHz	-13.30	-13.67	-14.10	-8.91	4.23	Complies
	2437 MHz	-11.26	-12.29	-12.57	-7.23	4.23	Complies
	2462 MHz	-12.57	-13.18	-13.86	-8.40	4.23	Complies
802.11n MCS0 HT20	2412 MHz	-15.07	-15.08	-15.10	-10.31	4.23	Complies
	2437 MHz	-8.67	-12.67	-12.50	-6.09	4.23	Complies
	2462 MHz	-14.35	-14.36	-14.02	-9.47	4.23	Complies
802.11n MCS0 HT40	2422 MHz	-19.11	-18.60	-18.86	-14.08	4.23	Complies
	2437 MHz	-15.65	-16.00	-15.29	-10.87	4.23	Complies
	2452 MHz	-17.67	-17.52	-17.06	-12.64	4.23	Complies

Note: $DirectionalGain = 10 \cdot \log \left[\frac{\sum_{j=1}^{N_{SS}} \left\{ \sum_{k=1}^{N_{ANT}} g_{j,k} \right\}^2}{N_{ANT}} \right] = 9.77\text{dBi}$, so limit = $8 - (9.77 - 6) = 4.23\text{dBm/MHz}$

Note: All the test values were listed in the report.

For plots, only the channel with worse result was shown.

Power Density Plot on Configuration IEEE 802.11b / 2437 MHz / Chain 1

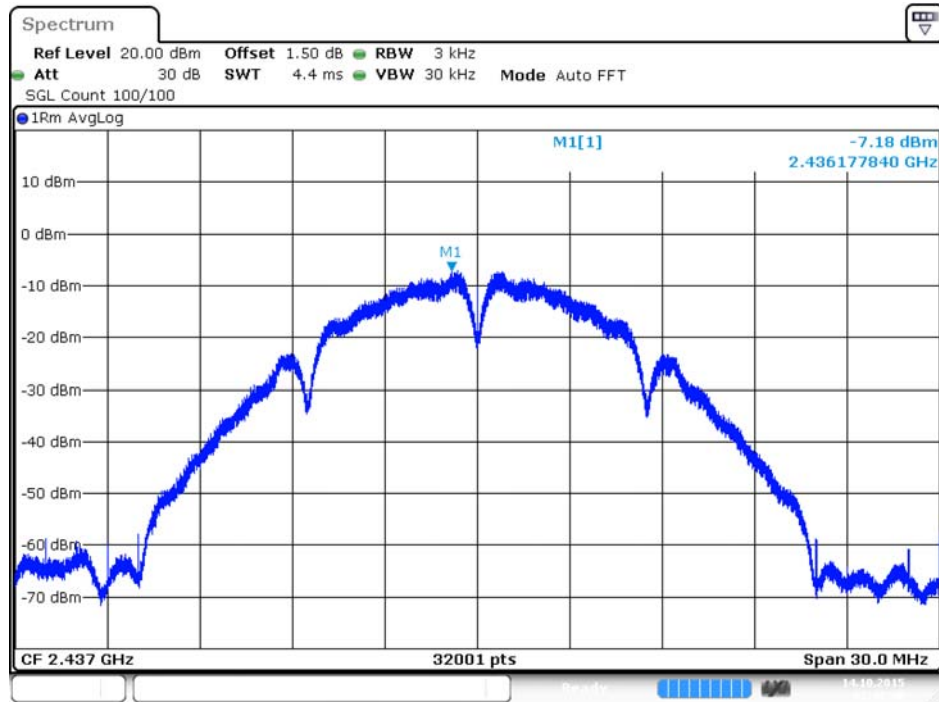

Power Density Plot on Configuration IEEE 802.11b / 2437 MHz / Chain 2

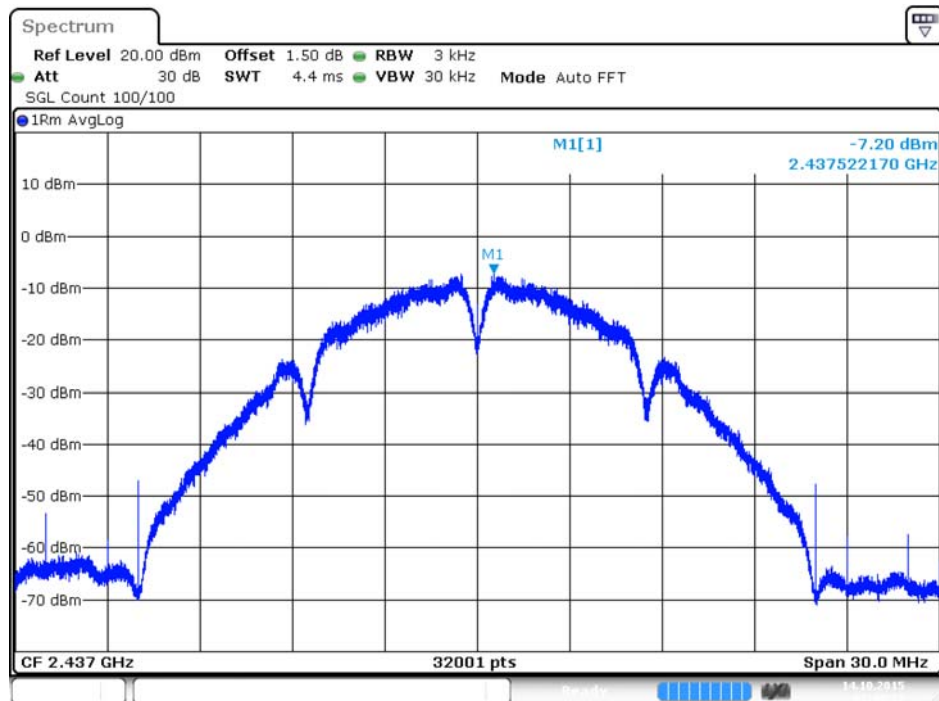

Power Density Plot on Configuration IEEE 802.11b / 2437 MHz / Chain 3

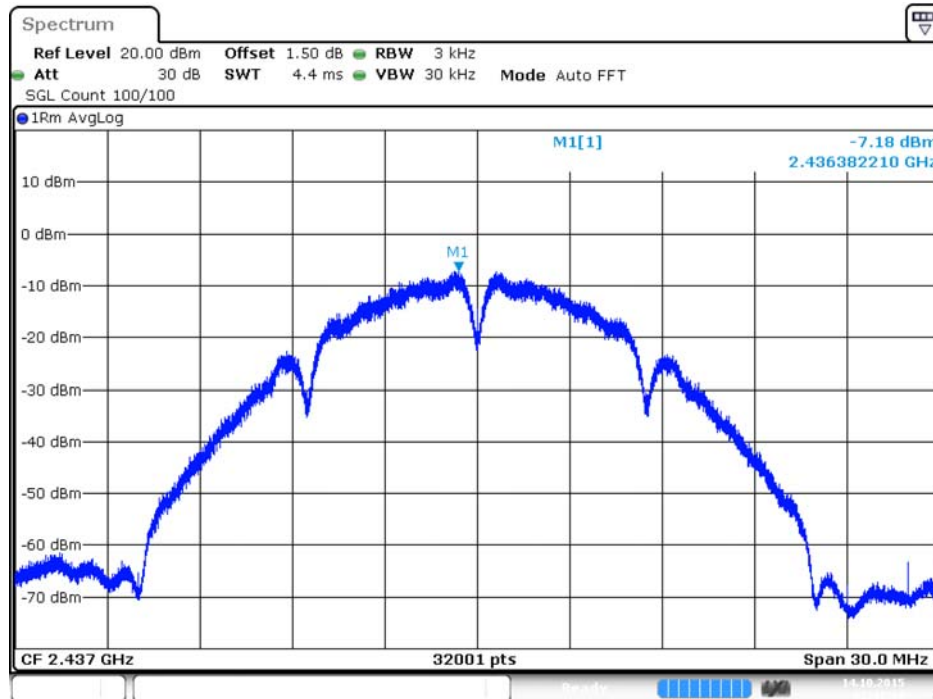

Power Density Plot on Configuration IEEE 802.11g / 2437 MHz / Chain 1

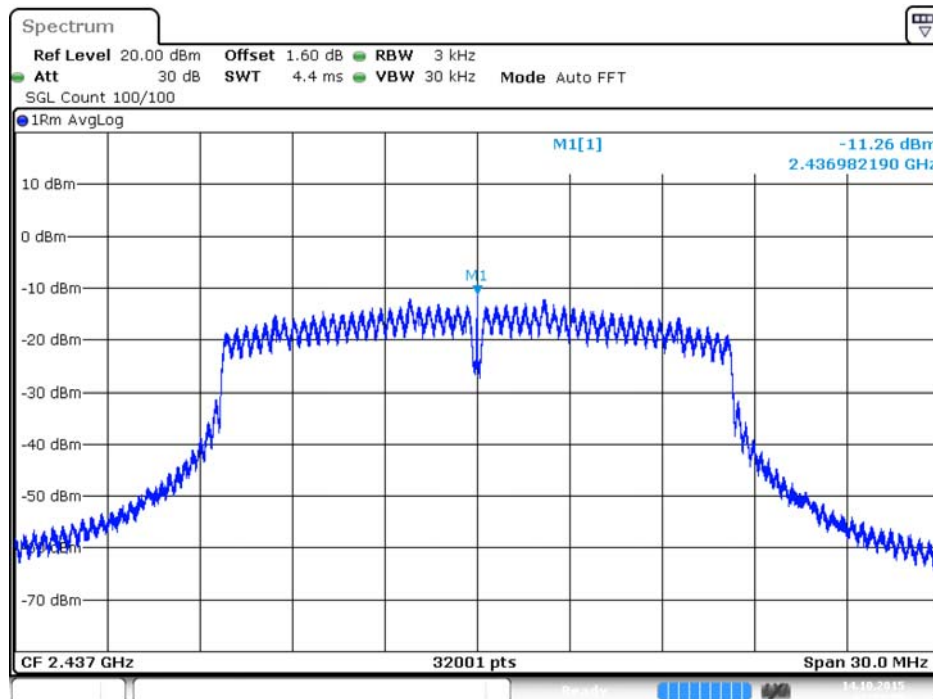

Power Density Plot on Configuration IEEE 802.11g / 2437 MHz / Chain 2

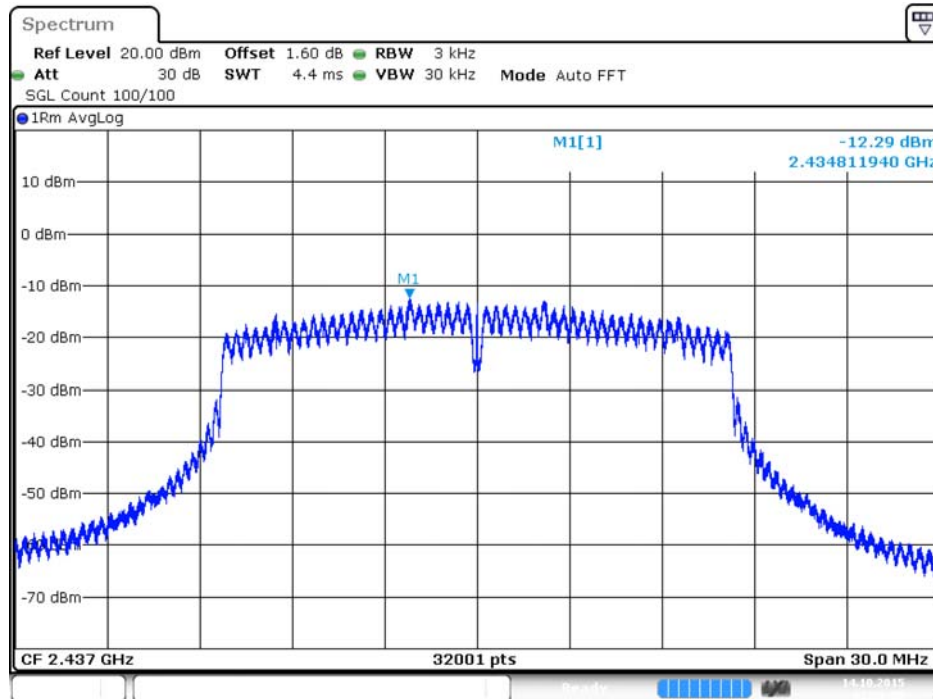

Power Density Plot on Configuration IEEE 802.11g / 2437 MHz / Chain 3

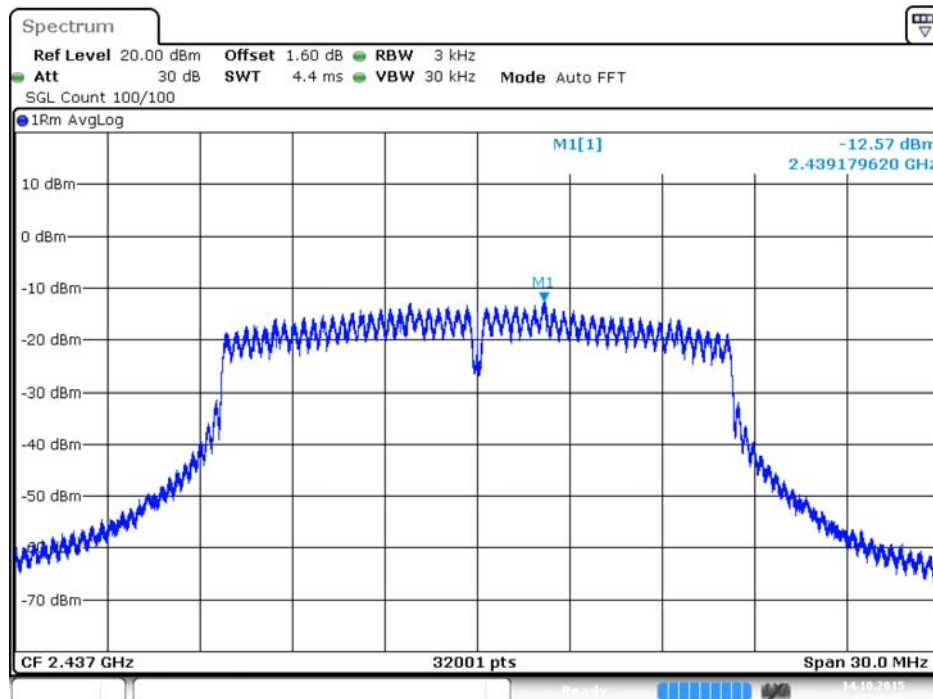

Power Density Plot on Configuration IEEE 802.11n MCS0 HT20 / 2437 MHz / Chain 1

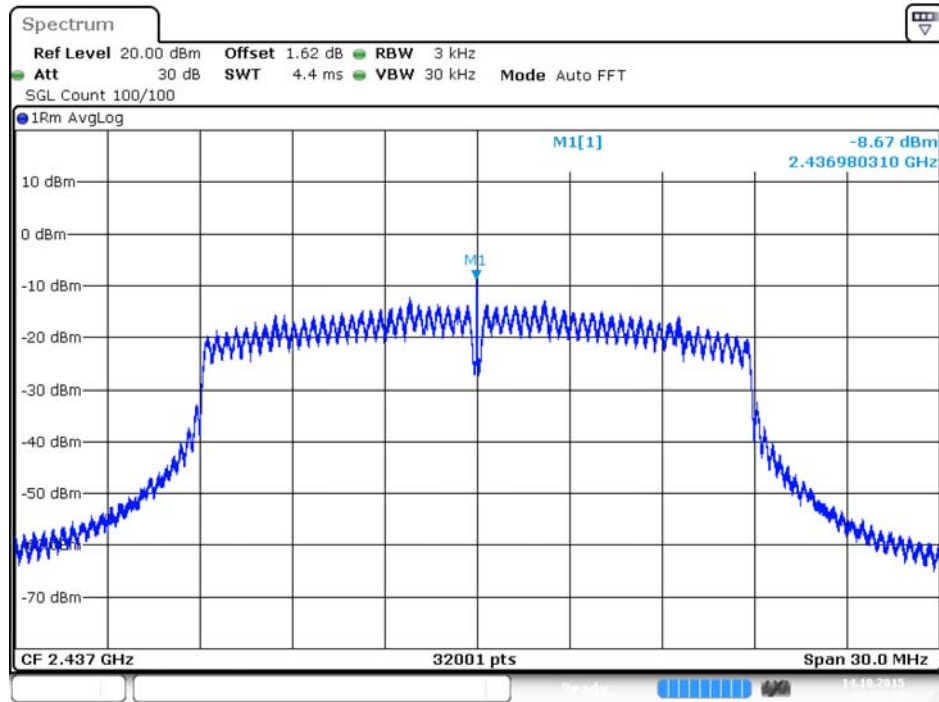

Power Density Plot on Configuration IEEE 802.11n MCS0 HT20 / 2437 MHz / Chain 2

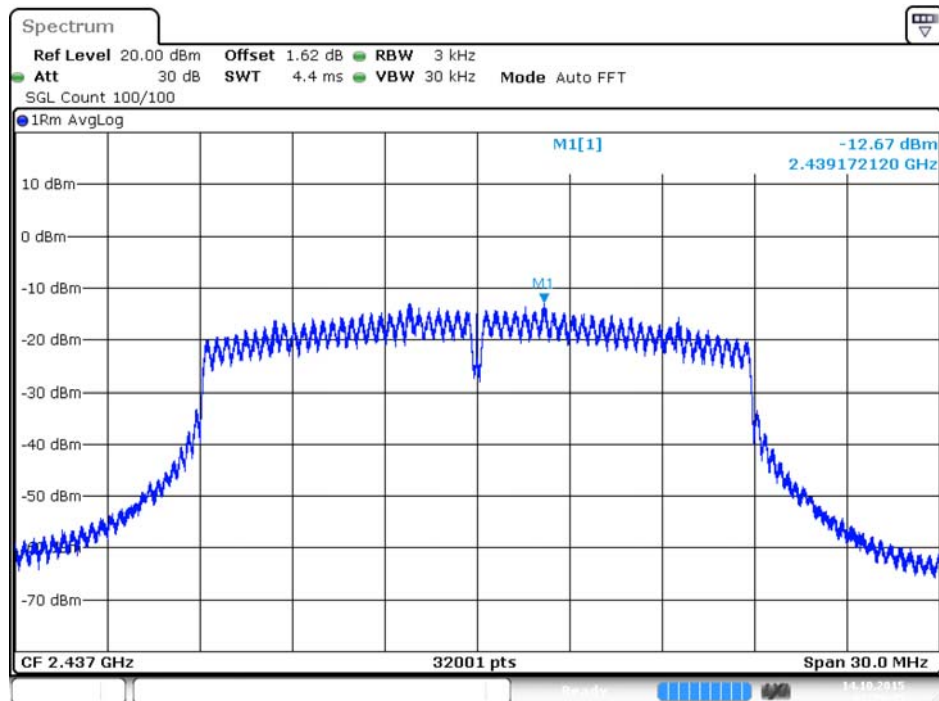

Power Density Plot on Configuration IEEE 802.11n MCS0 HT20 / 2437 MHz / Chain 3

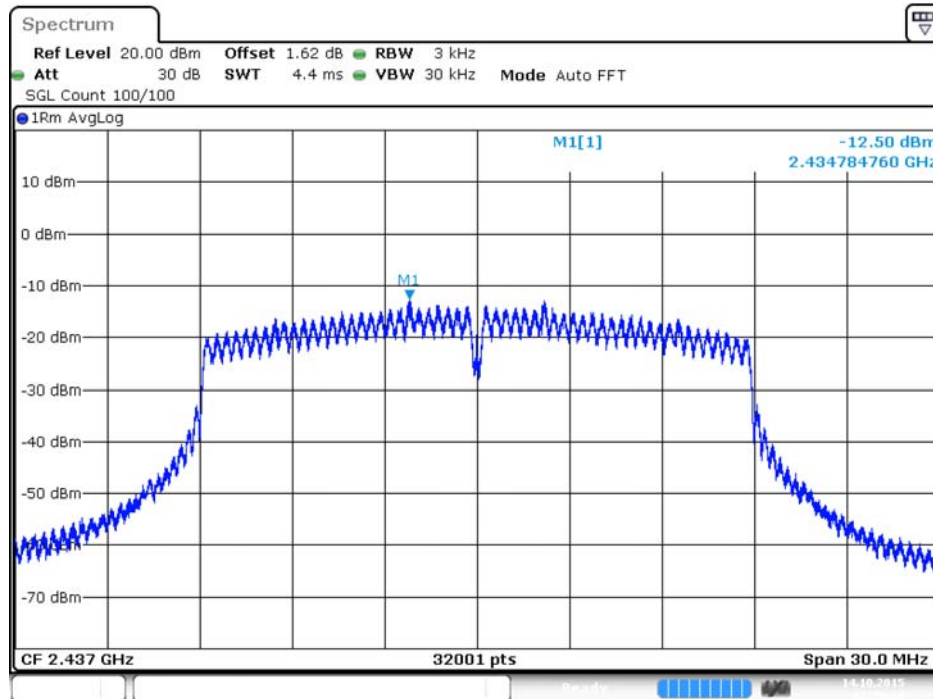

Power Density Plot on Configuration IEEE 802.11n MCS0 HT40 / 2437 MHz / Chain 1

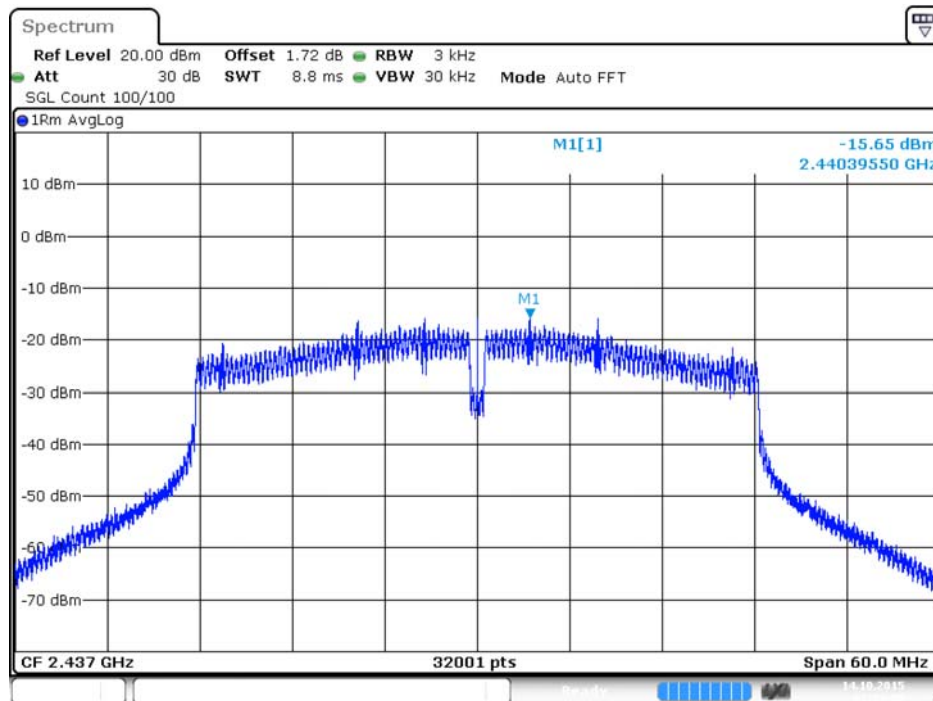

Power Density Plot on Configuration IEEE 802.11n MCS0 HT40 / 2437 MHz / Chain 2

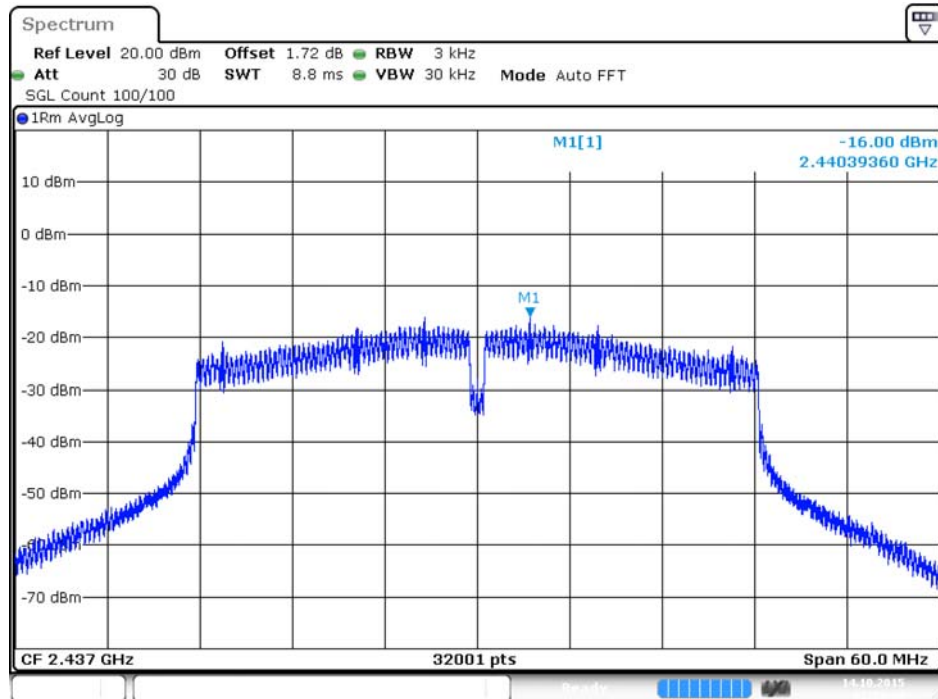

Power Density Plot on Configuration IEEE 802.11n MCS0 HT40 / 2437 MHz / Chain 3

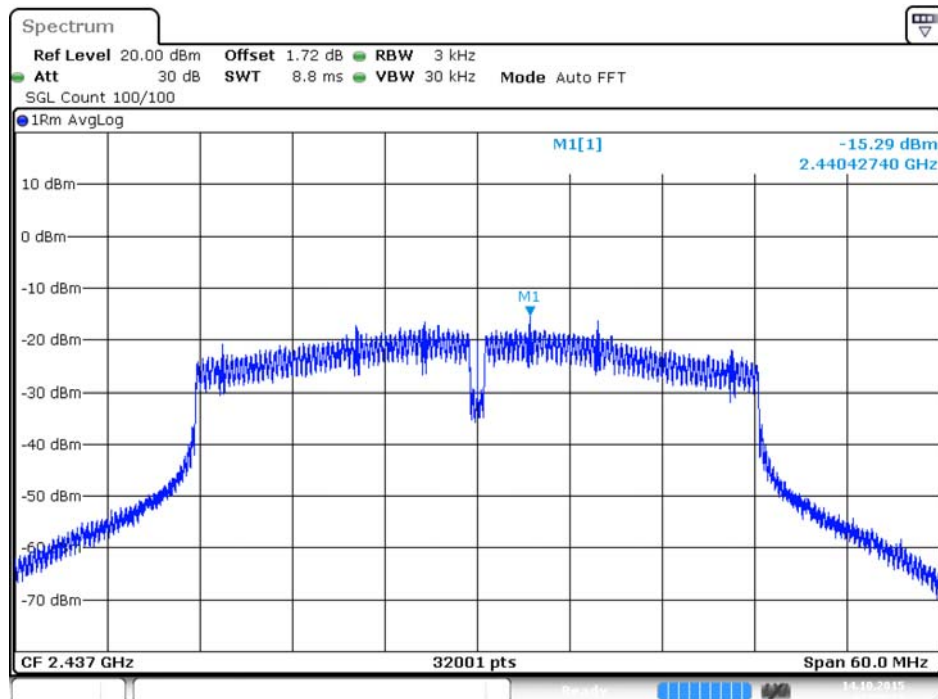

4.4. 6dB Spectrum Bandwidth Measurement

4.4.1. Limit

For digital modulation systems, the minimum 6 dB bandwidth shall be at least 500 kHz.

4.4.2. Measuring Instruments and Setting

Please refer to section 5 of equipments list in this report. The following table is the setting of the Spectrum Analyzer.

6dB Spectrum Bandwidth	
Spectrum Parameters	Setting
Attenuation	Auto
Span Frequency	> 6dB Bandwidth
RBW	100kHz
VBW	$\geq 3 \times \text{RBW}$
Detector	Peak
Trace	Max Hold
Sweep Time	Auto
99% Occupied Bandwidth	
Spectrum Parameters	Setting
Span	1.5 times to 5.0 times the OBW
RBW	1 % to 5 % of the OBW
VBW	$\geq 3 \times \text{RBW}$
Detector	Peak
Trace	Max Hold

4.4.3. Test Procedures

For Radiated 6dB Bandwidth Measurement:

1. The transmitter was radiated to the spectrum analyzer in peak hold mode.
2. Test was performed in accordance with KDB558074 D01 v03r03 for Performing Compliance Measurements on Digital Transmission Systems (DTS) - section 8.0 DTS bandwidth = > 8.1 Option 1.
3. Multiple antenna system was performed in accordance with KDB 662911 D01 v02r01 Emissions Testing of Transmitters with Multiple Outputs in the Same Band.
4. Measured the spectrum width with power higher than 6dB below carrier.

4.4.4. Test Setup Layout

For Radiated 6dB Bandwidth Measurement:

This test setup layout is the same as that shown in section 4.5.4.

4.4.5. Test Deviation

There is no deviation with the original standard.

4.4.6. EUT Operation during Test

The EUT was programmed to be in continuously transmitting mode.

4.4.7. Test Result of 6dB Spectrum Bandwidth

Temperature	24°C	Humidity	51%
Test Engineer	Kenneth Huang		

Mode	Frequency	6dB Bandwidth (MHz)	99% Occupied Bandwidth (MHz)	Min. Limit (kHz)	Test Result
802.11b	2412 MHz	5.52	11.88	500	Complies
	2437 MHz	5.12	12.48	500	Complies
	2462 MHz	5.52	12.24	500	Complies
802.11g	2412 MHz	12.96	15.00	500	Complies
	2437 MHz	10.08	15.24	500	Complies
	2462 MHz	11.36	16.20	500	Complies
802.11n MCS0 HT20	2412 MHz	15.04	16.92	500	Complies
	2437 MHz	15.36	17.76	500	Complies
	2462 MHz	14.72	17.76	500	Complies
802.11n MCS0 HT40	2422 MHz	25.12	36.00	500	Complies
	2437 MHz	29.92	35.80	500	Complies
	2452 MHz	28.80	36.20	500	Complies

Note: All the test values were listed in the report.

For plots, only the channel with worse result was shown.

6 dB Bandwidth Plot on Configuration IEEE 802.11b / 2437 MHz / Chain 1 + Chain 2 + Chain 3

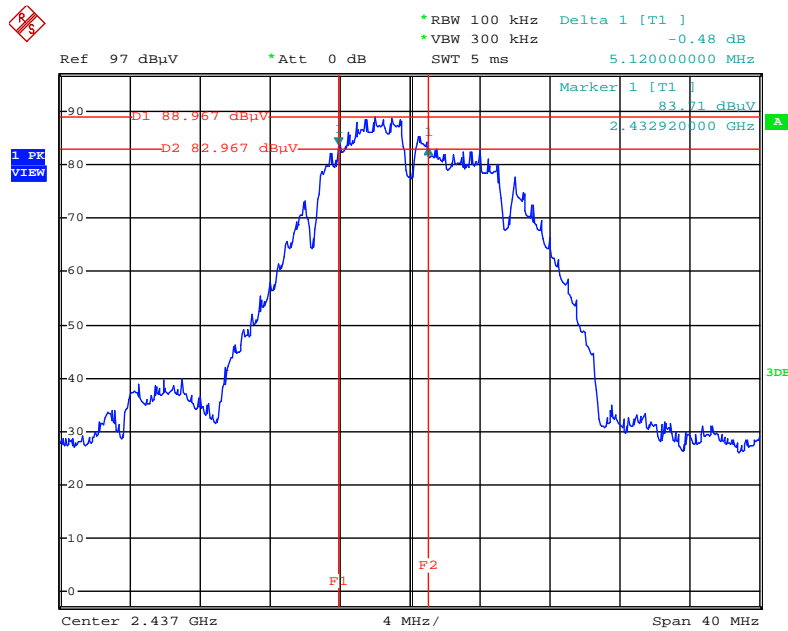

Date: 14.OCT.2015 00:49:20

99% Occupied Bandwidth Plot on Configuration IEEE 802.11b / 2437 MHz / Chain 1 + Chain 2 + Chain 3

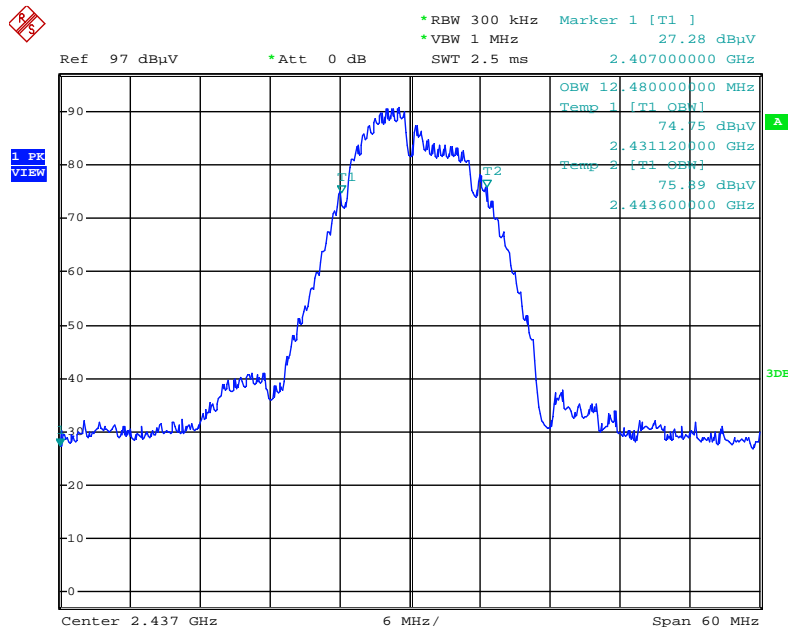

Date: 14.OCT.2015 00:49:50

6 dB Bandwidth Plot on Configuration IEEE 802.11g / 2437 MHz / Chain 1 + Chain 2 + Chain 3

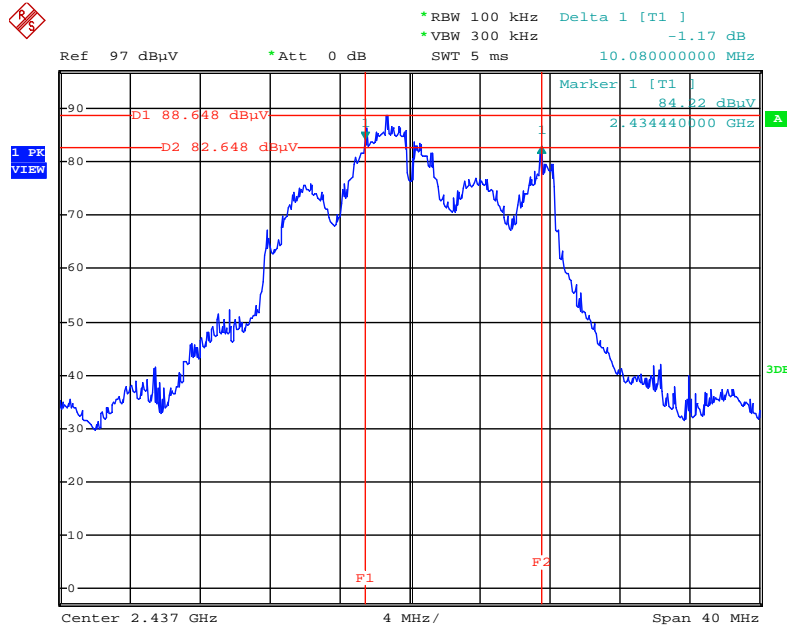

Date: 14.OCT.2015 00:53:51

99% Occupied Bandwidth Plot on Configuration IEEE 802.11g / 2462 MHz / Chain 1 + Chain 2 + Chain 3

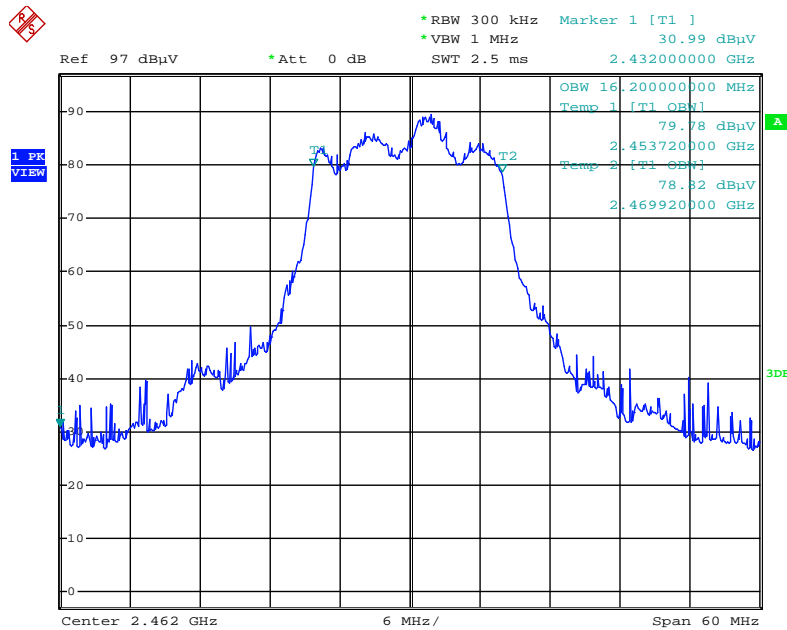

Date: 14.OCT.2015 00:52:42

6 dB Bandwidth Plot on Configuration IEEE 802.11n MCS0 HT20 / 2462 MHz / Chain 1 + Chain 2 + Chain 3

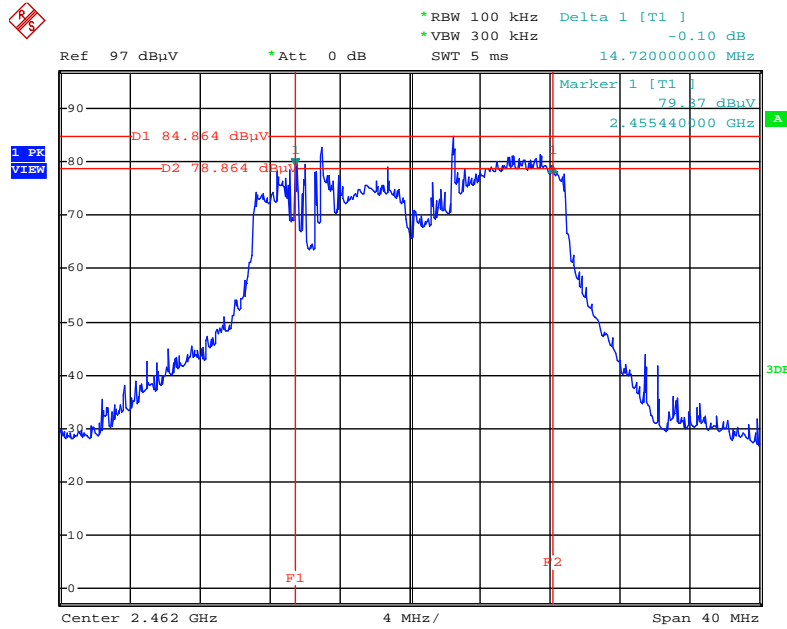

Date: 14.OCT.2015 00:58:43

99% Occupied Bandwidth Plot on Configuration IEEE 802.11n MCS0 HT20 / 2437 MHz / Chain 1 + Chain 2 + Chain 3

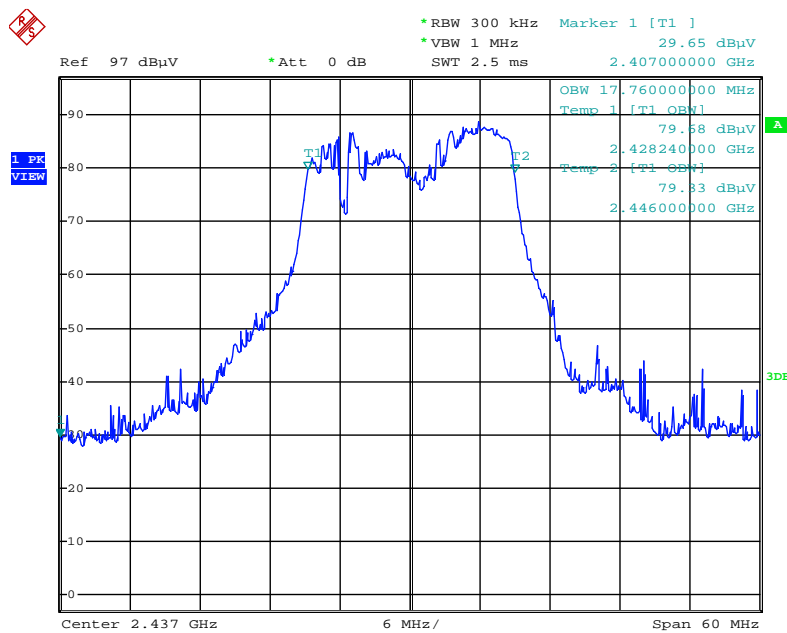

Date: 14.OCT.2015 00:57:39

6 dB Bandwidth Plot on Configuration IEEE 802.11n MCS0 HT40 / 2422 MHz / Chain 1 + Chain 2 + Chain 3

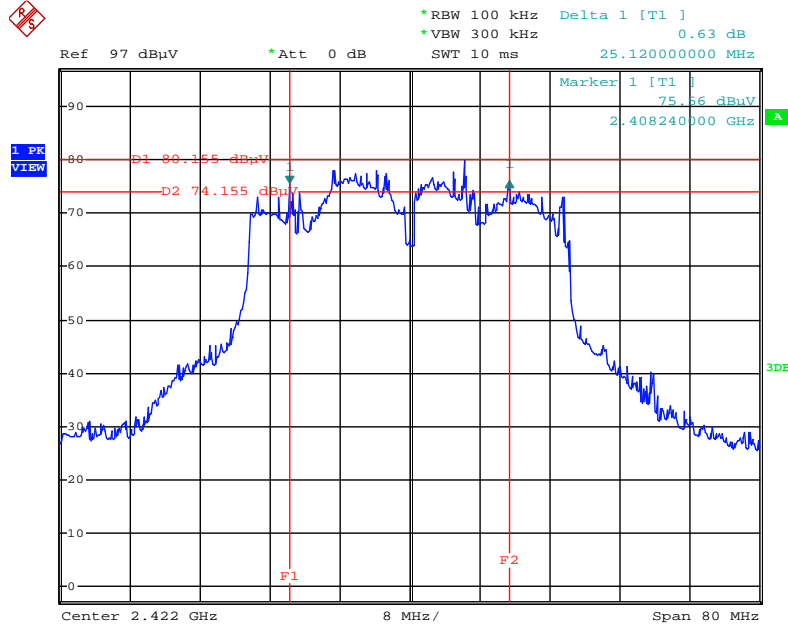

Date: 14.OCT.2015 00:59:56

99% Occupied Bandwidth Plot on Configuration IEEE 802.11n MCS0 HT40 / 2452 MHz / Chain 1 + Chain 2 + Chain 3

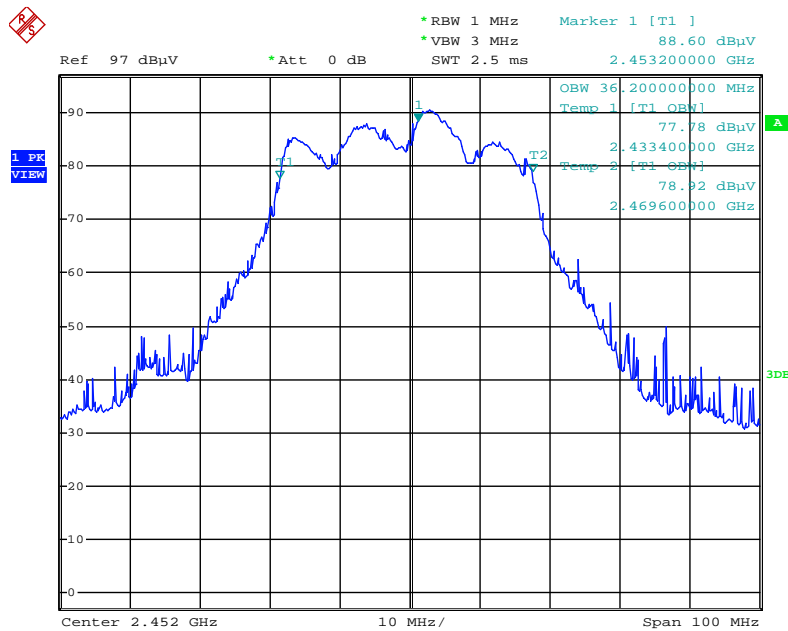

Date: 14.OCT.2015 01:03:00

4.5. Radiated Emissions Measurement

4.5.1. Limit

30dBc in any 100 kHz bandwidth outside the operating frequency band. In case the emission fall within the restricted band specified on 15.205(a), then the 15.209(a) limit in the table below has to be followed.

Frequencies (MHz)	Field Strength (micorvolts/meter)	Measurement Distance (meters)
0.009~0.490	2400/F(kHz)	300
0.490~1.705	24000/F(kHz)	30
1.705~30.0	30	30
30~88	100	3
88~216	150	3
216~960	200	3
Above 960	500	3

4.5.2. Measuring Instruments and Setting

Please refer to section 5 of equipments list in this report. The following table is the setting of spectrum analyzer and receiver.

Spectrum Parameter	Setting
Attenuation	Auto
Start Frequency	1000 MHz
Stop Frequency	10th carrier harmonic
RBW / VBW (Emission in restricted band)	1MHz / 3MHz for Peak, 1MHz / 1/T for Average
RBW / VBW (Emission in non-restricted band)	100kHz / 300kHz for peak

Receiver Parameter	Setting
Attenuation	Auto
Start ~ Stop Frequency	9kHz~150kHz / RBW 200Hz for QP
Start ~ Stop Frequency	150kHz~30MHz / RBW 9kHz for QP
Start ~ Stop Frequency	30MHz~1000MHz / RBW 120kHz for QP

4.5.3. Test Procedures

1. Configure the EUT according to ANSI C63.10. The EUT was placed on the top of the turntable 1.5 meter above ground. The phase center of the receiving antenna mounted on the top of a height-variable antenna tower was placed 1m & 3m far away from the turntable.
2. Power on the EUT and all the supporting units. The turntable was rotated by 360 degrees to determine the position of the highest radiation.
3. The height of the broadband receiving antenna was varied between one meter and four meters above ground to find the maximum emissions field strength of both horizontal and vertical polarization.
4. For each suspected emissions, the antenna tower was scan (from 1 m to 4 m) and then the turntable was rotated (from 0 degree to 360 degrees) to find the maximum reading.
5. Set the test-receiver system to Peak or CISPR quasi-peak Detect Function with specified bandwidth under Maximum Hold Mode.
6. For emissions above 1GHz, use 1MHz VBW and 3MHz RBW for peak reading. Then 1MHz RBW and 1/T VBW for average reading in spectrum analyzer.
7. If the emissions level of the EUT in peak mode was 3 dB lower than the average limit specified, then testing will be stopped and peak values of EUT will be reported, otherwise, the emissions which do not have 3 dB margin will be repeated one by one using the quasi-peak method for below 1GHz.
8. For testing above 1GHz, the emissions level of the EUT in peak mode was lower than average limit (that means the emissions level in peak mode also complies with the limit in average mode), then testing will be stopped and peak values of EUT will be reported, otherwise, the emissions will be measured in average mode again and reported.
9. In case the emission is lower than 30MHz, loop antenna has to be used for measurement and the recorded data should be QP measured by receiver. High – Low scan is not required in this case.

4.5.4. Test Setup Layout

For Radiated Emissions: 9kHz ~30MHz

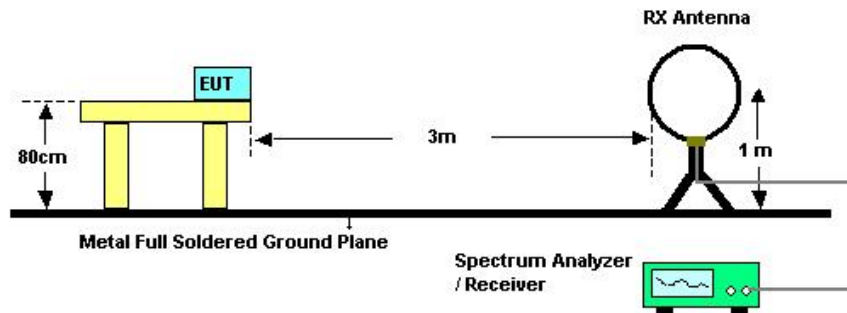

For Radiated Emissions: 30MHz~1GHz

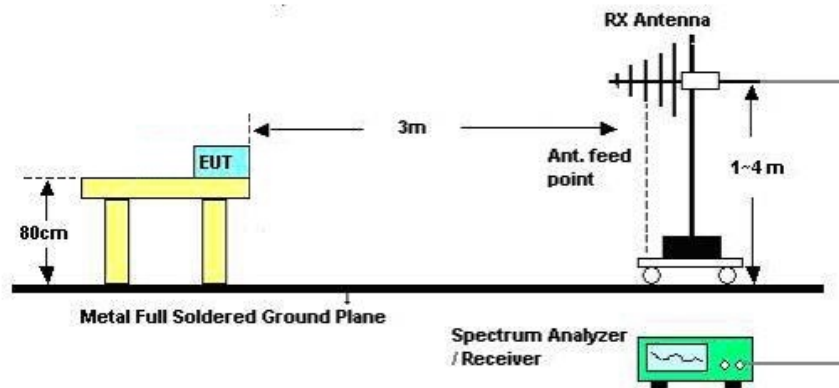

For Radiated Emissions: Above 1GHz

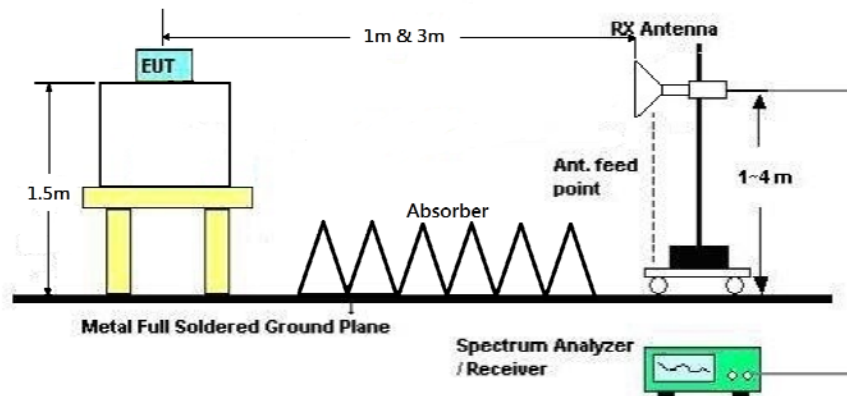

4.5.5. Test Deviation

There is no deviation with the original standard.

4.5.6. EUT Operation during Test

The EUT was programmed to be in continuously transmitting mode.

4.5.7. Results of Radiated Emissions (9kHz~30MHz)

Temperature	26°C	Humidity	59%
Test Engineer	Peter Wu	Configurations	Normal Link
Test Date	Oct. 07, 2015		

Freq. (MHz)	Level (dBuV)	Over Limit (dB)	Limit Line (dBuV)	Remark
-	-	-	-	See Note

Note:

The amplitude of spurious emissions which are attenuated by more than 20 dB below the permissible value has no need to be reported.

Distance extrapolation factor = $40 \log(\text{specific distance} / \text{test distance})$ (dB);

Limit line = specific limits (dBuV) + distance extrapolation factor.

4.5.8. Results of Radiated Emissions (30MHz~1GHz)

Temperature	26°C	Humidity	59%
Test Engineer	Peter Wu	Configurations	Normal Link

Horizontal

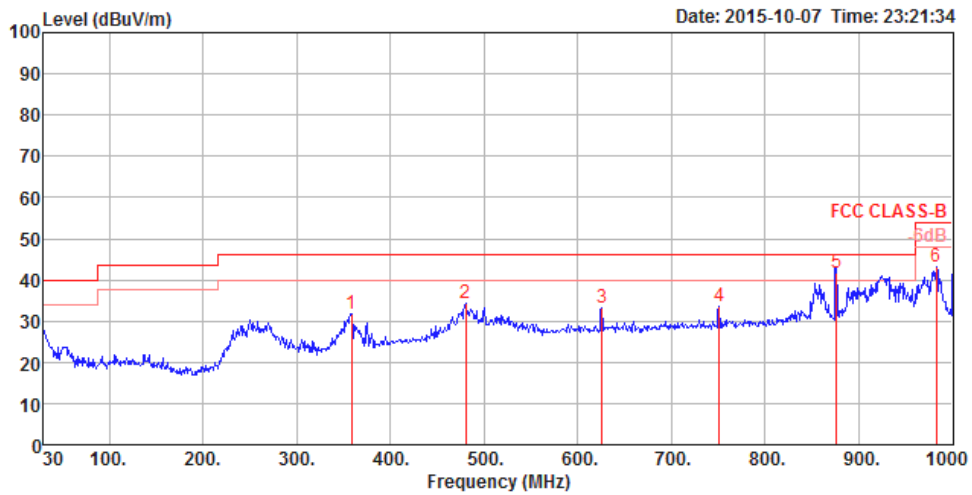

	Freq	Level	Limit	Over	Read	CableAntenna	Preamp	A/Pos	T/Pos	Remark	Pol/Phase
	MHz	dBuV/m	dBuV/m	dB	dBuV	dB	dB/m	dB	cm	deg	
1	358.83	31.68	46.00	-14.32	46.83	1.64	15.52	32.31	100	234 Peak	HORIZONTAL
2	480.08	34.21	46.00	-11.79	47.15	1.87	17.54	32.35	100	244 Peak	HORIZONTAL
3	625.58	33.27	46.00	-12.73	44.23	2.08	19.36	32.40	150	32 Peak	HORIZONTAL
4	750.71	33.76	46.00	-12.24	43.44	2.22	20.40	32.30	125	202 Peak	HORIZONTAL
5	875.84	41.54	46.00	-4.46	49.50	2.40	21.50	31.86	100	212 QP	HORIZONTAL
6	982.54	43.32	54.00	-10.68	49.58	2.53	22.20	30.99	150	214 Peak	HORIZONTAL

Vertical

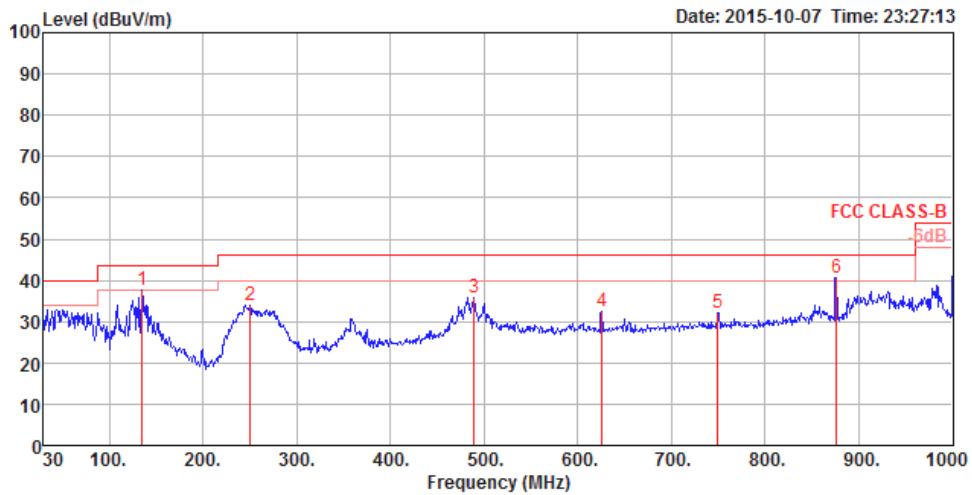

	Freq	Level	Limit	Over	Read	CableAntenna	Preamp	A/Pos	T/Pos	Remark	Pol/Phase	
	MHz	dBuV/m	dBuV/m	dB	dBuV	dB	dB/m	dB	cm	deg		
1	134.76	37.49	43.50	-6.01	56.38	1.06	12.41	32.36	125	185	Peak	VERTICAL
2	250.19	34.00	46.00	-12.00	52.02	1.38	12.90	32.30	150	313	Peak	VERTICAL
3	489.78	35.72	46.00	-10.28	48.53	1.88	17.66	32.35	125	163	Peak	VERTICAL
4	625.58	32.37	46.00	-13.63	43.33	2.08	19.36	32.40	100	138	Peak	VERTICAL
5	749.74	32.04	46.00	-13.96	41.72	2.22	20.40	32.30	100	131	Peak	VERTICAL
6	875.84	40.46	46.00	-5.54	48.42	2.40	21.50	31.86	150	199	Peak	VERTICAL

Note:

The amplitude of spurious emissions which are attenuated by more than 20 dB below the permissible value has no need to be reported.

Emission level (dBuV/m) = 20 log Emission level (uV/m).

Corrected Reading: Antenna Factor + Cable Loss + Read Level - Preamp Factor = Level.

4.5.9. Results for Radiated Emissions (1GHz~10th Harmonic)

Temperature	26°C	Humidity	59%
Test Engineer	Peter Wu	Configurations	IEEE 802.11b CH 1 / Chain 1 + Chain 2 + Chain 3
Test Date	Oct. 09, 2015		

Horizontal

	Freq	Level	Limit	Over	Read	CableAntenna	Preamp	A/Pos	T/Pos	Pol/Phase	Remark
	MHz	dBuV/m	dBuV/m	dB	dBuV	dB	dB/m	dB	cm	deg	
1	4824.14	50.06	74.00	-23.94	46.52	5.38	32.55	34.39	114	45	HORIZONTAL Peak
2	4824.17	41.48	54.00	-12.52	37.94	5.38	32.55	34.39	114	45	HORIZONTAL Average

Vertical

	Freq	Level	Limit	Over	Read	CableAntenna	Preamp	A/Pos	T/Pos	Pol/Phase	Remark
	MHz	dBuV/m	dBuV/m	dB	dBuV	dB	dB/m	dB	cm	deg	
1	4824.18	51.48	74.00	-22.52	47.94	5.38	32.55	34.39	239	314	VERTICAL Peak
2	4824.26	45.54	54.00	-8.46	42.00	5.38	32.55	34.39	239	314	VERTICAL Average

Temperature	26°C	Humidity	59%
Test Engineer	Peter Wu	Configurations	IEEE 802.11b CH 6 / Chain 1 + Chain 2 + Chain 3
Test Date	Oct. 09, 2015		

Horizontal

	Freq	Level	Limit	Over	Read	Cable	Antenna	Preamp	A/Pos	T/Pos	Pol/Phase	Remark
	MHz	dBuV/m	dBuV/m	dB	dBuV	Loss	Factor	Factor	cm	deg		
1	4874.14	46.36	54.00	-7.64	42.68	5.40	32.66	34.38	125	92	HORIZONTAL	Average
2	4874.24	50.91	74.00	-23.09	47.23	5.40	32.66	34.38	125	92	HORIZONTAL	Peak

Vertical

	Freq	Level	Limit	Limit	Level	Loss	Factor	Factor	A/Pos	T/Pos	Pol/Phase	Remark
	MHz	dBuV/m	dBuV/m	dB	dBuV	dB	dB/m	dB	cm	deg		
1	4874.20	47.39	54.00	-6.61	43.71	5.40	32.66	34.38	195	12	VERTICAL	Average
2	4874.23	52.32	74.00	-21.68	48.64	5.40	32.66	34.38	195	12	VERTICAL	Peak

Temperature	26°C	Humidity	59%
Test Engineer	Peter Wu	Configurations	IEEE 802.11b CH 11 / Chain 1 + Chain 2 + Chain 3
Test Date	Oct. 09, 2015		

Horizontal

	Freq	Level	Limit Line	Over Limit	Read Level	CableAntenna Loss	Antenna Factor	Preamp Factor	A/Pos	T/Pos	Pol/Phase	Remark
	MHz	dBuV/m	dBuV/m	dB	dBuV	dB	dB/m	dB	cm	deg		
1	4924.16	49.19	74.00	-24.81	45.38	5.42	32.76	34.37	142	103	HORIZONTAL	Peak
2	4924.25	45.36	54.00	-8.64	41.55	5.42	32.76	34.37	142	103	HORIZONTAL	Average

Vertical

	Freq	Level	Limit Line	Over Limit	Read Level	CableAntenna Loss	Antenna Factor	Preamp Factor	A/Pos	T/Pos	Pol/Phase	Remark
	MHz	dBuV/m	dBuV/m	dB	dBuV	dB	dB/m	dB	cm	deg		
1	4924.24	50.72	74.00	-23.28	46.91	5.42	32.76	34.37	148	20	VERTICAL	Peak
2	4924.24	47.44	54.00	-6.56	43.63	5.42	32.76	34.37	148	20	VERTICAL	Average

Temperature	26°C	Humidity	59%
Test Engineer	Peter Wu	Configurations	IEEE 802.11g CH 1 / Chain 1 + Chain 2 + Chain 3
Test Date	Oct. 09, 2015		

Horizontal

	Freq	Level	Limit	Over	Read	Cable	Antenna	Preamp	A/Pos	T/Pos	Pol/Phase	Remark
	MHz	dBuV/m	dBuV/m	dB	dBuV	Loss	Factor	Factor	cm	deg		
1	4824.15	32.78	54.00	-21.22	29.24	5.38	32.55	34.39	150	124	HORIZONTAL	Average
2	4824.59	46.20	74.00	-27.80	42.66	5.38	32.55	34.39	150	124	HORIZONTAL	Peak

Vertical

	Freq	Level	Limit	Over	Read	Cable	Antenna	Preamp	A/Pos	T/Pos	Pol/Phase	Remark
	MHz	dBuV/m	dBuV/m	dB	dBuV	Loss	Factor	Factor	cm	deg		
1	4823.79	32.74	54.00	-21.26	29.20	5.38	32.55	34.39	133	71	VERTICAL	Average
2	4823.92	45.82	74.00	-28.18	42.28	5.38	32.55	34.39	133	71	VERTICAL	Peak

Temperature	26°C	Humidity	59%
Test Engineer	Peter Wu	Configurations	IEEE 802.11g CH 6 / Chain 1 + Chain 2 + Chain 3
Test Date	Oct. 09, 2015		

Horizontal

	Freq	Level	Limit	Over	Read	CableAntenna	Preamp	A/Pos	T/Pos	Pol/Phase	Remark
	MHz	dBuV/m	dBuV/m	dB	dBuV	Loss	Factor	Factor	cm	deg	
1	4873.30	45.36	74.00	-28.64	41.68	5.40	32.66	34.38	150	207	HORIZONTAL Peak
2	4873.74	32.81	54.00	-21.19	29.13	5.40	32.66	34.38	150	207	HORIZONTAL Average

Vertical

	Freq	Level	Limit	Over	Read	CableAntenna	Preamp	A/Pos	T/Pos	Pol/Phase	Remark
	MHz	dBuV/m	dBuV/m	dB	dBuV	Loss	Factor	Factor	cm	deg	
1	4873.14	34.19	54.00	-19.81	30.51	5.40	32.66	34.38	144	310	VERTICAL Average
2	4873.32	47.28	74.00	-26.72	43.60	5.40	32.66	34.38	144	310	VERTICAL Peak

Temperature	26°C	Humidity	59%
Test Engineer	Peter Wu	Configurations	IEEE 802.11g CH 11 / Chain 1 + Chain 2 + Chain 3
Test Date	Oct. 09, 2015		

Horizontal

	Freq	Level	Limit Line	Over Limit	Read Level	CableAntenna Loss	Antenna Factor	Preamp Factor	A/Pos	T/Pos	Pol/Phase	Remark
	MHz	dBuV/m	dBuV/m	dB	dBuV	dB	dB/m	dB	cm	deg		
1	4923.18	45.33	74.00	-28.67	41.54	5.42	32.74	34.37	150	281	HORIZONTAL	Peak
2	4923.63	32.56	54.00	-21.44	28.75	5.42	32.76	34.37	150	281	HORIZONTAL	Average

Vertical

	Freq	Level	Limit Line	Over Limit	Read Level	CableAntenna Loss	Antenna Factor	Preamp Factor	A/Pos	T/Pos	Pol/Phase	Remark
	MHz	dBuV/m	dBuV/m	dB	dBuV	dB	dB/m	dB	cm	deg		
1	4923.71	46.59	74.00	-27.41	42.78	5.42	32.76	34.37	133	24	VERTICAL	Peak
2	4924.02	33.18	54.00	-20.82	29.37	5.42	32.76	34.37	133	24	VERTICAL	Average

Temperature	26°C	Humidity	59%
Test Engineer	Peter Wu	Configurations	IEEE 802.11n MCS0 HT20 CH 1 / Chain 1 + Chain 2 + Chain 3
Test Date	Oct. 09, 2015		

Horizontal

	Freq	Level	Limit	Over	Read	Cable	Antenna	Preamp	A/Pos	T/Pos	Pol/Phase	Remark
	MHz	dBuV/m	dBuV/m	dB	dBuV	Loss	Factor	Factor	cm	deg		
1	4823.41	32.59	54.00	-21.41	29.05	5.38	32.55	34.39	150	159	HORIZONTAL	Average
2	4823.66	45.26	74.00	-28.74	41.72	5.38	32.55	34.39	150	159	HORIZONTAL	Peak

Vertical

	Freq	Level	Limit	Over	Read	Cable	Antenna	Preamp	A/Pos	T/Pos	Pol/Phase	Remark
	MHz	dBuV/m	dBuV/m	dB	dBuV	Loss	Factor	Factor	cm	deg		
1	4823.90	32.99	54.00	-21.01	29.45	5.38	32.55	34.39	137	322	VERTICAL	Average
2	4824.58	45.81	74.00	-28.19	42.27	5.38	32.55	34.39	137	322	VERTICAL	Peak

Temperature	26°C	Humidity	59%
Test Engineer	Peter Wu	Configurations	IEEE 802.11n MCS0 HT20 CH 6 / Chain 1 + Chain 2 + Chain 3
Test Date	Oct. 09, 2015		

Horizontal

	Freq	Level	Limit	Over	Read	Cable	Antenna	Preamp	A/Pos	T/Pos	Pol/Phase	Remark
	MHz	dBuV/m	dBuV/m	dB	dBuV	Loss	Factor	Factor	cm	deg		
1	4874.25	33.11	54.00	-20.89	29.43	5.40	32.66	34.38	150	246	HORIZONTAL	Average
2	4874.95	45.72	74.00	-28.28	42.04	5.40	32.66	34.38	150	246	HORIZONTAL	Peak

Vertical

	Freq	Level	Limit	Over	Read	Cable	Antenna	Preamp	A/Pos	T/Pos	Pol/Phase	Remark
	MHz	dBuV/m	dBuV/m	dB	dBuV	Loss	Factor	Factor	cm	deg		
1	4873.02	33.67	54.00	-20.33	29.99	5.40	32.66	34.38	138	313	VERTICAL	Average
2	4873.59	46.46	74.00	-27.54	42.78	5.40	32.66	34.38	138	313	VERTICAL	Peak

Temperature	26°C	Humidity	59%
Test Engineer	Peter Wu	Configurations	IEEE 802.11n MCS0 HT20 CH 11 / Chain 1 + Chain 2 + Chain 3
Test Date	Oct. 09, 2015		

Horizontal

	Freq	Level	Limit Line	Over Limit	Read Level	Cable Loss	Antenna Factor	Preamp Factor	A/Pos	T/Pos	Pol/Phase	Remark
	MHz	dBuV/m	dBuV/m	dB	dBuV	dB	dB/m	dB	cm	deg		
1	4923.04	32.53	54.00	-21.47	28.74	5.42	32.74	34.37	150	64	HORIZONTAL	Average
2	4923.23	46.07	74.00	-27.93	42.28	5.42	32.74	34.37	150	64	HORIZONTAL	Peak

Vertical

	Freq	Level	Limit Line	Over Limit	Read Level	Cable Loss	Antenna Factor	Preamp Factor	A/Pos	T/Pos	Pol/Phase	Remark
	MHz	dBuV/m	dBuV/m	dB	dBuV	dB	dB/m	dB	cm	deg		
1	4923.08	45.39	74.00	-28.61	41.60	5.42	32.74	34.37	142	198	VERTICAL	Peak
2	4923.42	32.50	54.00	-21.50	28.71	5.42	32.74	34.37	142	198	VERTICAL	Average

Temperature	26°C	Humidity	59%
Test Engineer	Peter Wu	Configurations	IEEE 802.11n MCS0 HT40 CH 3 / Chain 1 + Chain 2 + Chain 3
Test Date	Oct. 09, 2015		

Horizontal

	Freq	Level	Limit	Over	Read	Cable	Antenna	Preamp	A/Pos	T/Pos	Pol/Phase	Remark
	MHz	dBuV/m	dBuV/m	dB	dBuV	Loss	Factor	Factor	cm	deg		
1	4843.58	32.60	54.00	-21.40	29.00	5.39	32.60	34.39	150	208	HORIZONTAL	Average
2	4844.58	45.33	74.00	-28.67	41.73	5.39	32.60	34.39	150	208	HORIZONTAL	Peak

Vertical

	Freq	Level	Limit	Over	Read	Cable	Antenna	Preamp	A/Pos	T/Pos	Pol/Phase	Remark
	MHz	dBuV/m	dBuV/m	dB	dBuV	Loss	Factor	Factor	cm	deg		
1	4844.43	32.54	54.00	-21.46	28.94	5.39	32.60	34.39	143	96	VERTICAL	Average
2	4844.52	45.42	74.00	-28.58	41.82	5.39	32.60	34.39	143	96	VERTICAL	Peak

Temperature	26°C	Humidity	59%
Test Engineer	Peter Wu	Configurations	IEEE 802.11n MCS0 HT40 CH 6 / Chain 1 + Chain 2 + Chain 3
Test Date	Oct. 09, 2015		

Horizontal

	Freq	Level	Limit	Over	Read	CableAntenna	Preamp	A/Pos	T/Pos	Pol/Phase	Remark
	MHz	dBuV/m	dBuV/m	dB	dBuV	Loss	Factor	cm	deg		
1	4873.03	45.34	74.00	-28.66	41.66	5.40	32.66	150	237	HORIZONTAL	Peak
2	4873.22	32.63	54.00	-21.37	28.95	5.40	32.66	150	237	HORIZONTAL	Average

Vertical

	Freq	Level	Limit	Over	Read	CableAntenna	Preamp	A/Pos	T/Pos	Pol/Phase	Remark
	MHz	dBuV/m	dBuV/m	dB	dBuV	Loss	Factor	cm	deg		
1	4873.64	45.99	74.00	-28.01	42.31	5.40	32.66	135	222	VERTICAL	Peak
2	4874.53	32.86	54.00	-21.14	29.18	5.40	32.66	135	222	VERTICAL	Average

Temperature	26°C	Humidity	59%
Test Engineer	Peter Wu	Configurations	IEEE 802.11n MCS0 HT40 CH 9 / Chain 1 + Chain 2 + Chain 3
Test Date	Oct. 09, 2015		

Horizontal

	Freq	Level	Limit	Over	Read	Cable	Antenna	Preamp	A/Pos	T/Pos	Pol/Phase	Remark
	MHz	dBuV/m	dBuV/m	dB	dBuV	Loss	Factor	Factor	cm	deg		
1	4903.19	32.77	54.00	-21.23	29.03	5.41	32.71	34.38	150	120	HORIZONTAL	Average
2	4903.32	45.95	74.00	-28.05	42.21	5.41	32.71	34.38	150	120	HORIZONTAL	Peak

Vertical

	Freq	Level	Limit	Over	Read	Cable	Antenna	Preamp	A/Pos	T/Pos	Pol/Phase	Remark
	MHz	dBuV/m	dBuV/m	dB	dBuV	Loss	Factor	Factor	cm	deg		
1	4904.22	45.87	74.00	-28.13	42.13	5.41	32.71	34.38	144	55	VERTICAL	Peak
2	4904.82	32.60	54.00	-21.40	28.86	5.41	32.71	34.38	144	55	VERTICAL	Average

Note:

The amplitude of spurious emissions that are attenuated by more than 20dB below the permissible value has no need to be reported.

Emission level (dBuV/m) = 20 log Emission level (uV/m).

Corrected Reading: Antenna Factor + Cable Loss + Read Level - Preamp Factor = Level.

4.6. Emissions Measurement

4.6.1. Limit

30dBc in any 100 kHz bandwidth outside the operating frequency band. In case the emission fall within the restricted band specified on 15.205(a), then the 15.209(a) limit in the table below has to be followed.

Frequencies (MHz)	Field Strength (micorvolts/meter)	Measurement Distance (meters)
0.009~0.490	2400/F(kHz)	300
0.490~1.705	24000/F(kHz)	30
1.705~30.0	30	30
30~88	100	3
88~216	150	3
216~960	200	3
Above 960	500	3

4.6.2. Measuring Instruments and Setting

Please refer to section 5 of equipments list in this report. The following table is the setting of the spectrum analyzer.

Spectrum Parameter	Setting
Attenuation	Auto
Span Frequency	100 MHz
RBW / VBW (Emission in restricted band)	1 MHz / 3 MHz for Peak, 1 MHz / 1/T for Average
RBW / VBW (30dBc in any 100 kHz bandwidth emission)	100 kHz / 300 kHz for Peak

4.6.3. Test Procedures

For Radiated band edges Measurement:

1. The test procedure is the same as section 4.5.3.

For Radiated Out of Band Emission Measurement:

1. Test was performed in accordance with KDB558074 D01 v03r03 for Performing Compliance Measurements on Digital Transmission Systems (DTS) Operating Under §15.247 section 10.1 Unwanted Emissions into Non-Restricted Frequency Bands Measurement Procedure.

4.6.4. Test Setup Layout

For Radiated band edges Measurement:

This test setup layout is the same as that shown in section 4.5.4.

For Radiated Out of Band Emission Measurement:

This test setup layout is the same as that shown in section 4.5.4.

4.6.5. Test Deviation

There is no deviation with the original standard.

4.6.6. EUT Operation during Test

The EUT was programmed to be in continuously transmitting mode.

4.6.7. Test Result of Band Edge and Fundamental Emissions

Temperature	26°C	Humidity	59%
Test Engineer	Peter Wu	Configurations	IEEE 802.11b CH 1, 6, 11 / Chain 1 + Chain 2 + Chain 3
Test Date	Oct. 08, 2015		

Channel 1

	Freq	Level	Limit	Over	Read	CableAntenna	Preamp	A/Pos	T/Pos	Pol/Phase	Remark
	MHz	dBuV/m	dBuV/m	dB	dBuV	dB	dB/m	dB	cm	deg	
1	2388.40	64.56	74.00	-9.44	32.91	3.73	27.92	0.00	150	187 VERTICAL	Peak
2	2390.00	53.60	54.00	-0.40	21.95	3.73	27.92	0.00	150	187 VERTICAL	Average
3	2412.80	116.05			84.41	3.75	27.89	0.00	150	187 VERTICAL	Average
4	2413.00	119.98			88.34	3.75	27.89	0.00	150	187 VERTICAL	Peak

Item 3, 4 are the fundamental frequency at 2412 MHz.

Channel 6

	Freq	Level	Limit	Over	Read	CableAntenna	Preamp	A/Pos	T/Pos	Pol/Phase	Remark
	MHz	dBuV/m	dBuV/m	dB	dBuV	dB	dB/m	dB	cm	deg	
1	2386.20	53.95	54.00	-0.05	22.30	3.73	27.92	0.00	146	157 VERTICAL	Average
2	2389.40	66.53	74.00	-7.47	34.88	3.73	27.92	0.00	146	157 VERTICAL	Peak
3	2436.20	122.18			90.54	3.77	27.87	0.00	146	157 VERTICAL	Average
4	2436.20	126.38			94.74	3.77	27.87	0.00	146	157 VERTICAL	Peak
5	2485.40	63.42	74.00	-10.58	31.78	3.82	27.82	0.00	146	157 VERTICAL	Peak
6	2487.80	51.54	54.00	-2.46	19.90	3.82	27.82	0.00	146	157 VERTICAL	Average

Item 3, 4 are the fundamental frequency at 2437 MHz.

Channel 11

	Freq	Level	Limit	Over	Read	CableAntenna	Preamp	A/Pos	T/Pos	Pol/Phase	Remark
	MHz	dBuV/m	dBuV/m	dB	dBuV	dB	dB/m	dB	cm	deg	
1	2460.00	119.68			88.04	3.79	27.85	0.00	146	354 VERTICAL	Peak
2	2460.40	116.31			84.67	3.79	27.85	0.00	146	354 VERTICAL	Average
3	2483.50	53.99	54.00	-0.01	22.35	3.82	27.82	0.00	146	354 VERTICAL	Average
4	2483.50	63.77	74.00	-10.23	32.13	3.82	27.82	0.00	146	354 VERTICAL	Peak

Item 1, 2 are the fundamental frequency at 2462 MHz.

Temperature	26°C	Humidity	59%
Test Engineer	Peter Wu	Configurations	IEEE 802.11g CH 1, 6, 11 / Chain 1 + Chain 2 + Chain 3
Test Date	Oct. 09, 2015		

Channel 1

	Freq	Level	Limit	Over	Read	CableAntenna	Preamp	A/Pos	T/Pos	Pol/Phase	Remark	
	MHz	dBuV/m	dBuV/m	dB	dBuV	dB	dB/m	dB	cm	deg		
1	2389.20	73.35	74.00	-0.65	41.70	3.73	27.92	0.00	146	189	VERTICAL	Peak
2	2390.00	53.96	54.00	-0.04	22.31	3.73	27.92	0.00	146	189	VERTICAL	Average
3	2409.00	123.60			91.95	3.75	27.90	0.00	146	189	VERTICAL	Peak
4	2409.20	111.38			79.73	3.75	27.90	0.00	146	189	VERTICAL	Average

Item 3, 4 are the fundamental frequency at 2412 MHz.

Channel 6

	Freq	Level	Limit	Over	Read	CableAntenna	Preamp	A/Pos	T/Pos	Pol/Phase	Remark	
	MHz	dBuV/m	dBuV/m	dB	dBuV	dB	dB/m	dB	cm	deg		
1	2390.00	53.79	54.00	-0.21	22.14	3.73	27.92	0.00	154	188	VERTICAL	Average
2	2390.00	65.47	74.00	-8.53	33.82	3.73	27.92	0.00	154	188	VERTICAL	Peak
3	2434.20	123.64			92.00	3.77	27.87	0.00	154	188	VERTICAL	Peak
4	2434.60	113.89			82.25	3.77	27.87	0.00	154	188	VERTICAL	Average
5	2487.80	51.78	54.00	-2.22	20.14	3.82	27.82	0.00	154	188	VERTICAL	Average
6	2509.40	63.87	74.00	-10.13	32.21	3.84	27.82	0.00	154	188	VERTICAL	Peak

Item 3, 4 are the fundamental frequency at 2437 MHz.

Channel 11

	Freq	Level	Limit	Over	Read	CableAntenna	Preamp	A/Pos	T/Pos	Pol/Phase	Remark	
	MHz	dBuV/m	dBuV/m	dB	dBuV	dB	dB/m	dB	cm	deg		
1	2460.00	113.42			81.78	3.79	27.85	0.00	156	178	VERTICAL	Average
2	2460.00	122.47			90.83	3.79	27.85	0.00	156	178	VERTICAL	Peak
3	2484.20	53.60	54.00	-0.40	21.96	3.82	27.82	0.00	156	178	VERTICAL	Average
4	2484.20	72.04	74.00	-1.96	40.40	3.82	27.82	0.00	156	178	VERTICAL	Peak

Item 1, 2 are the fundamental frequency at 2462 MHz.

Temperature	26°C	Humidity	59%
Test Engineer	Peter Wu	Configurations	IEEE 802.11n MCS0 HT20 CH 1, 6, 11 / Chain 1 + Chain 2 + Chain 3
Test Date	Oct. 09, 2015		

Channel 1

	Freq	Level	Limit Line	Over Limit	Read Level	CableAntenna Loss	Preamp Factor	A/Pos	T/Pos	Pol/Phase	Remark	
	MHz	dBuV/m	dBuV/m	dB	dBuV	dB	dB/m	dB	cm	deg		
1	2389.60	72.70	74.00	-1.30	41.05	3.73	27.92	0.00	146	178	VERTICAL	Peak
2	2390.00	53.55	54.00	-0.45	21.90	3.73	27.92	0.00	146	178	VERTICAL	Average
3	2408.60	110.71			79.06	3.75	27.90	0.00	146	178	VERTICAL	Average
4	2409.40	120.74			89.09	3.75	27.90	0.00	146	178	VERTICAL	Peak

Item 3, 4 are the fundamental frequency at 2412 MHz.

Channel 6

	Freq	Level	Limit Line	Over Limit	Read Level	CableAntenna Loss	Preamp Factor	A/Pos	T/Pos	Pol/Phase	Remark	
	MHz	dBuV/m	dBuV/m	dB	dBuV	dB	dB/m	dB	cm	deg		
1	2389.00	65.93	74.00	-8.07	34.28	3.73	27.92	0.00	147	157	VERTICAL	Peak
2	2390.00	53.59	54.00	-0.41	21.94	3.73	27.92	0.00	147	157	VERTICAL	Average
3	2437.40	123.11			91.47	3.77	27.87	0.00	147	157	VERTICAL	Peak
4	2438.20	114.13			82.49	3.77	27.87	0.00	147	157	VERTICAL	Average
5	2483.50	52.49	54.00	-1.51	20.85	3.82	27.82	0.00	147	157	VERTICAL	Average
6	2487.00	63.68	74.00	-10.32	32.04	3.82	27.82	0.00	147	157	VERTICAL	Peak

Item 3, 4 are the fundamental frequency at 2437 MHz.

Channel 11

	Freq	Level	Limit Line	Over Limit	Read Level	CableAntenna Loss	Preamp Factor	A/Pos	T/Pos	Pol/Phase	Remark	
	MHz	dBuV/m	dBuV/m	dB	dBuV	dB	dB/m	dB	cm	deg		
1	2463.00	122.01			90.38	3.79	27.84	0.00	127	151	VERTICAL	Peak
2	2463.40	112.12			80.48	3.80	27.84	0.00	127	151	VERTICAL	Average
3	2483.50	53.72	54.00	-0.28	22.08	3.82	27.82	0.00	127	151	VERTICAL	Average
4	2485.20	71.20	74.00	-2.80	39.56	3.82	27.82	0.00	127	151	VERTICAL	Peak

Item 1, 2 are the fundamental frequency at 2462 MHz.

Temperature	26°C	Humidity	59%
Test Engineer	Peter Wu	Configurations	IEEE 802.11n MCS0 HT40 CH 3, 6, 9 / Chain 1 + Chain 2 + Chain 3
Test Date	Oct. 09, 2015		

Channel 3

	Freq	Level	Limit	Over	Read	CableAntenna	Preamp	A/Pos	T/Pos	Pol/Phase	Remark
	MHz	dBuV/m	dBuV/m	dB	dBuV	dB	dB/m	dB	cm	deg	
1	2389.60	69.46	74.00	-4.54	37.81	3.73	27.92	0.00	144	196 VERTICAL	Peak
2	2390.00	53.96	54.00	-0.04	22.31	3.73	27.92	0.00	144	196 VERTICAL	Average
3	2419.60	107.30			75.65	3.76	27.89	0.00	144	196 VERTICAL	Average
4	2419.60	117.25			85.60	3.76	27.89	0.00	144	196 VERTICAL	Peak

Item 3, 4 are the fundamental frequency at 2422 MHz.

Channel 6

	Freq	Level	Limit	Over	Read	CableAntenna	Preamp	A/Pos	T/Pos	Pol/Phase	Remark
	MHz	dBuV/m	dBuV/m	dB	dBuV	dB	dB/m	dB	cm	deg	
1	2389.80	67.22	74.00	-6.78	35.57	3.73	27.92	0.00	150	197 VERTICAL	Peak
2	2390.00	53.58	54.00	-0.42	21.93	3.73	27.92	0.00	150	197 VERTICAL	Average
3	2429.00	118.72			87.08	3.76	27.88	0.00	150	197 VERTICAL	Peak
4	2430.20	109.04			77.40	3.76	27.88	0.00	150	197 VERTICAL	Average
5	2483.50	50.06	54.00	-3.94	18.42	3.82	27.82	0.00	150	197 VERTICAL	Average
6	2485.00	65.84	74.00	-8.16	34.20	3.82	27.82	0.00	150	197 VERTICAL	Peak

Item 3, 4 are the fundamental frequency at 2437 MHz.

Channel 9

	Freq	Level	Limit	Over	Read	CableAntenna	Preamp	A/Pos	T/Pos	Pol/Phase	Remark
	MHz	dBuV/m	dBuV/m	dB	dBuV	dB	dB/m	dB	cm	deg	
1	2454.00	107.94			76.31	3.78	27.85	0.00	142	360 VERTICAL	Average
2	2454.40	117.23			85.60	3.78	27.85	0.00	142	360 VERTICAL	Peak
3	2484.00	71.67	74.00	-2.33	40.03	3.82	27.82	0.00	142	360 VERTICAL	Peak
4	2492.00	53.58	54.00	-0.42	21.95	3.82	27.81	0.00	142	360 VERTICAL	Average

Item 1, 2 are the fundamental frequency at 2452 MHz.

Note:

Emission level (dBuV/m) = 20 log Emission level (uV/m).

Corrected Reading: Antenna Factor + Cable Loss + Read Level - Preamp Factor = Level.

For Emission not in Restricted Band

Plot on Configuration IEEE 802.11b / Reference Level

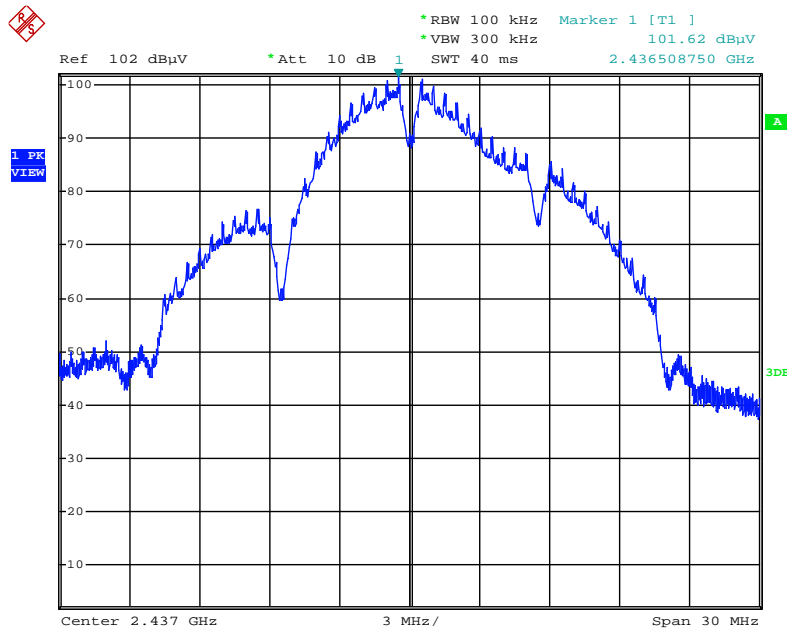

Date: 9.OCT.2015 02:36:16

Plot on Configuration IEEE 802.11b / CH 1 / 30MHz~2400MHz (down 30dBc)

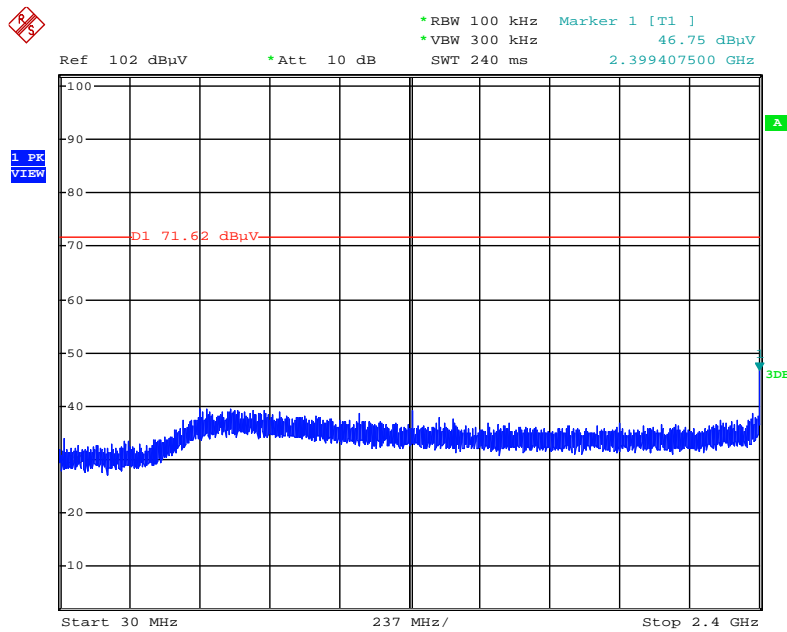

Date: 9.OCT.2015 02:39:15

Plot on Configuration IEEE 802.11b / CH 1 / 2500MHz~26500MHz (down 30dBc)

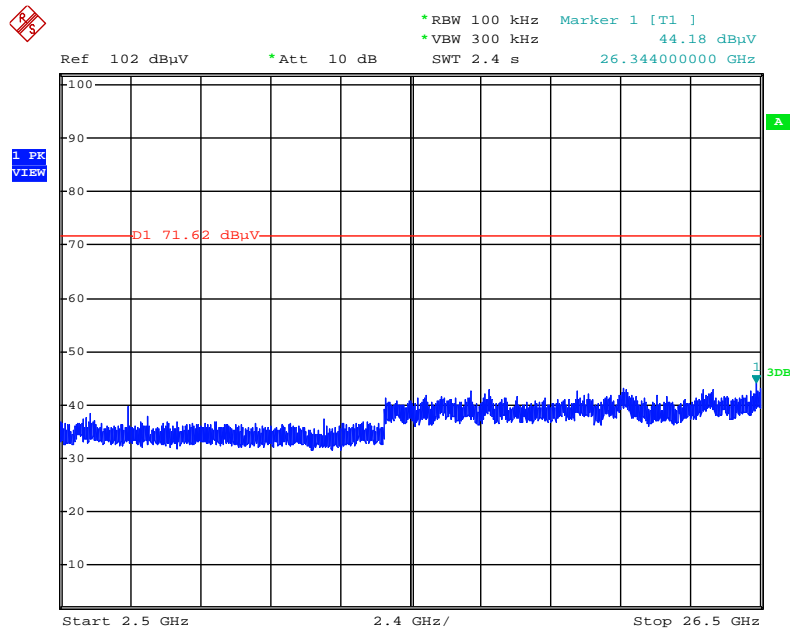

Date: 9.OCT.2015 02:40:20

Plot on Configuration IEEE 802.11b / CH 11 / 30MHz~2400MHz (down 30dBc)

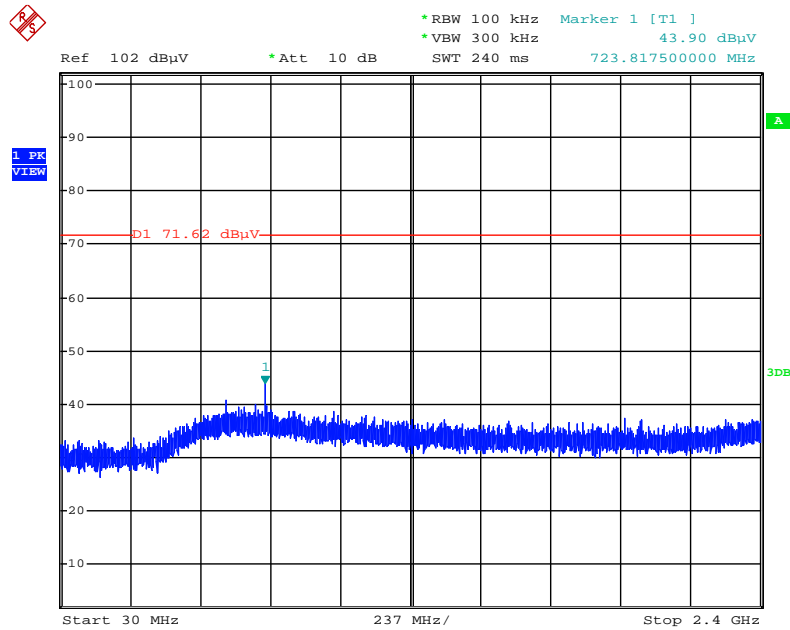

Date: 9.OCT.2015 02:42:32

Plot on Configuration IEEE 802.11b / CH 11 / 2500MHz~26500MHz (down 30dBc)

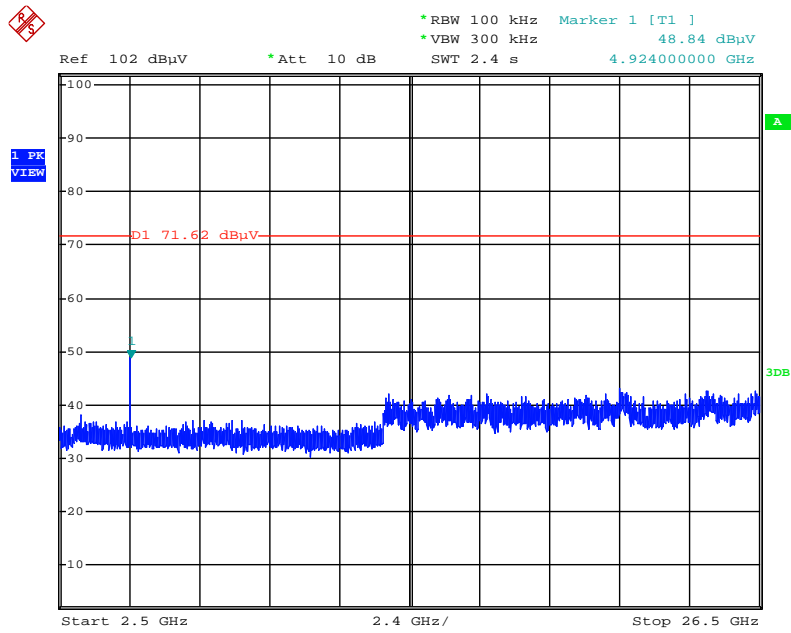

Date: 9.OCT.2015 02:43:01

Plot on Configuration IEEE 802.11g / Reference Level

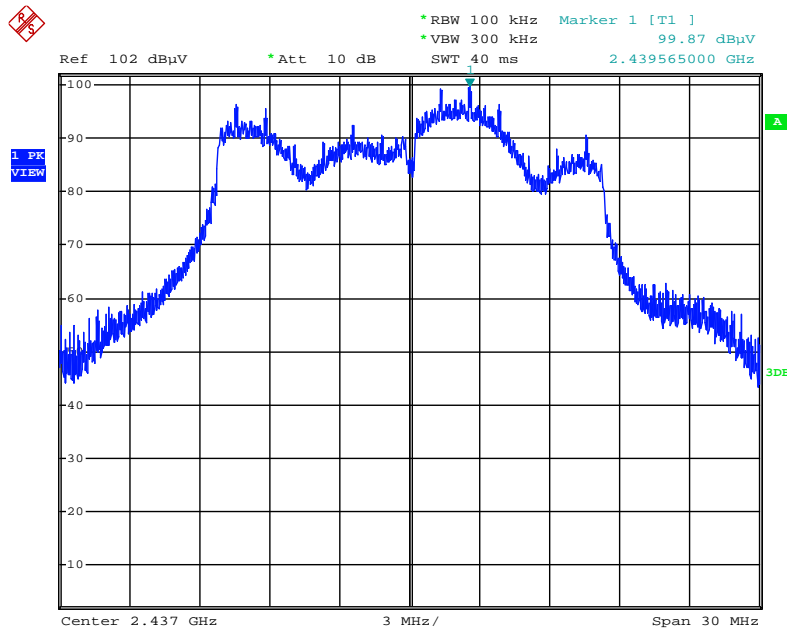

Date: 9.OCT.2015 02:44:32

Plot on Configuration IEEE 802.11g / CH 1 / 30MHz~2400MHz (down 30dBc)

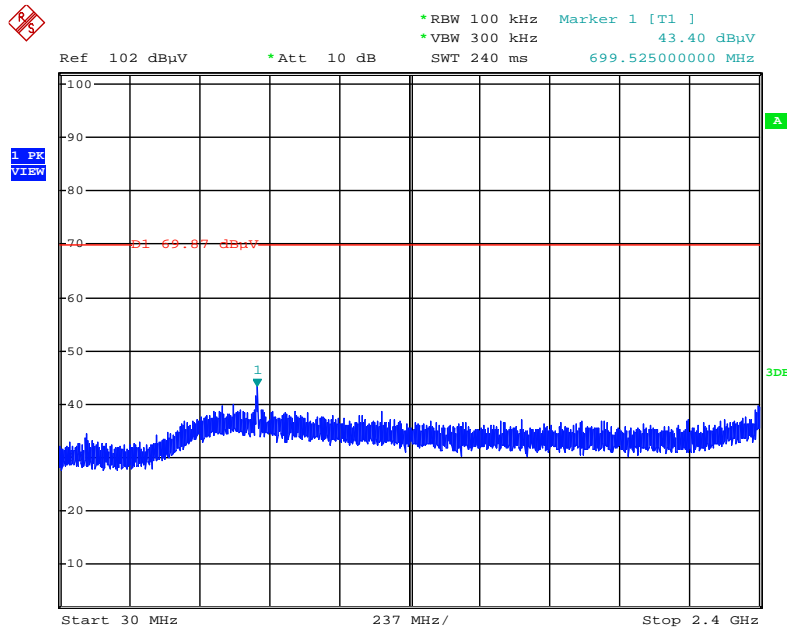

Date: 9.OCT.2015 02:46:31

Plot on Configuration IEEE 802.11g / CH 1 / 2500MHz~26500MHz (down 30dBc)

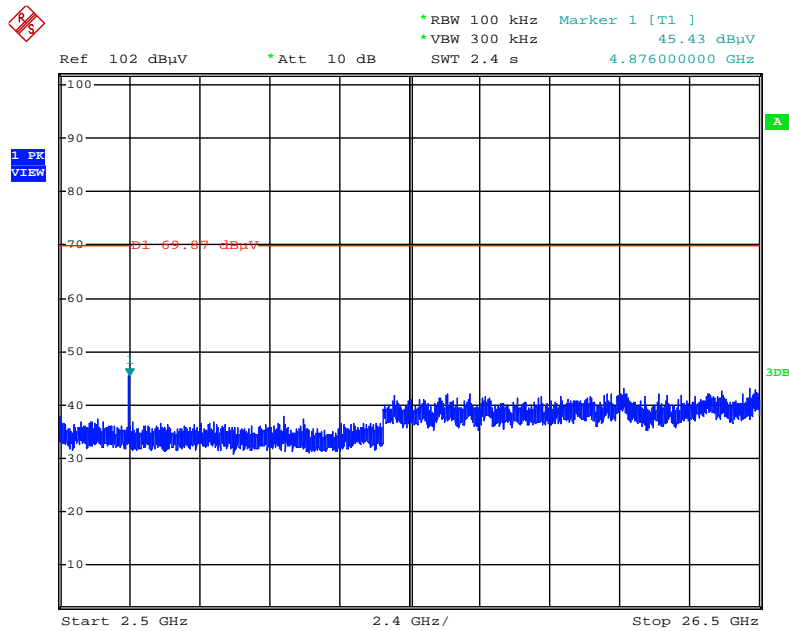

Date: 9.OCT.2015 02:47:07

Plot on Configuration IEEE 802.11g / CH 11 / 30MHz~2400MHz (down 30dBc)

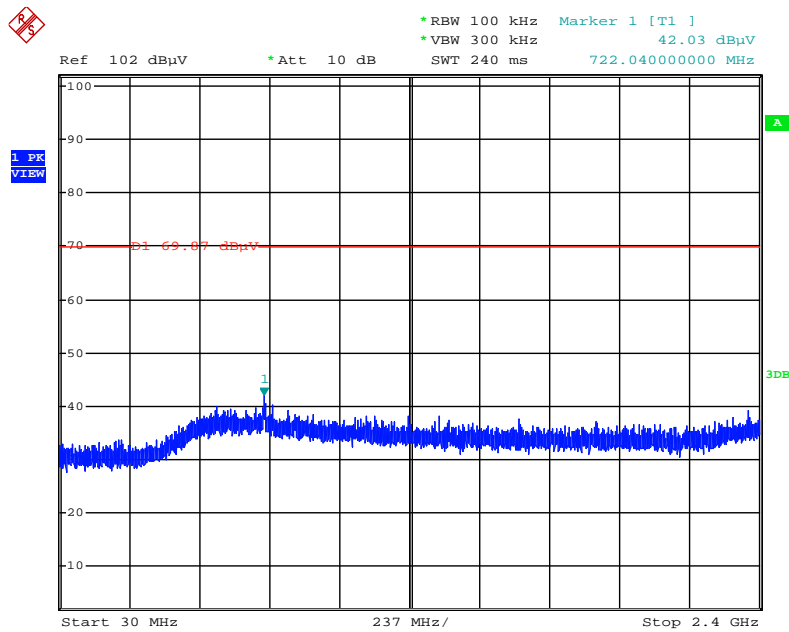

Date: 9.OCT.2015 02:49:19

Plot on Configuration IEEE 802.11g / CH 11 / 2500MHz~26500MHz (down 30dBc)

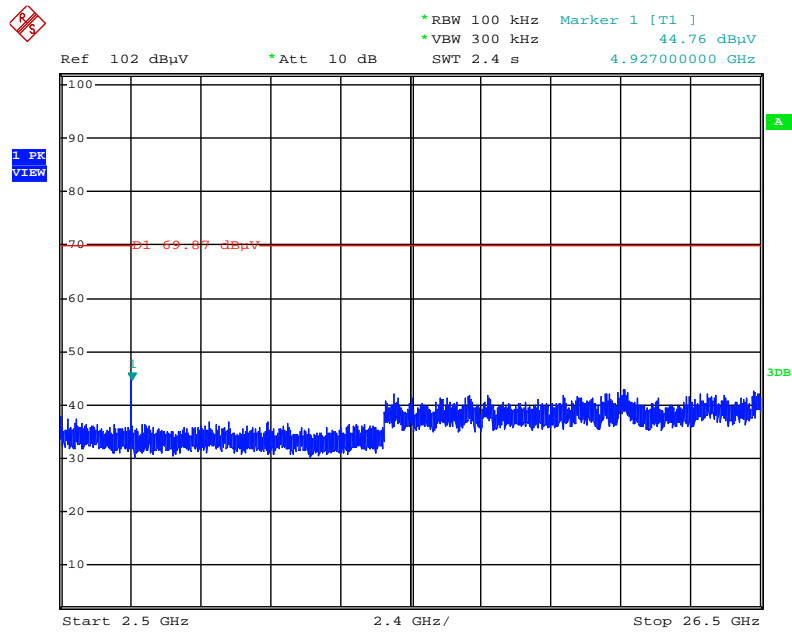

Date: 9.OCT.2015 02:49:52

Plot on Configuration IEEE 802.11n MCS0 HT20 / Reference Level

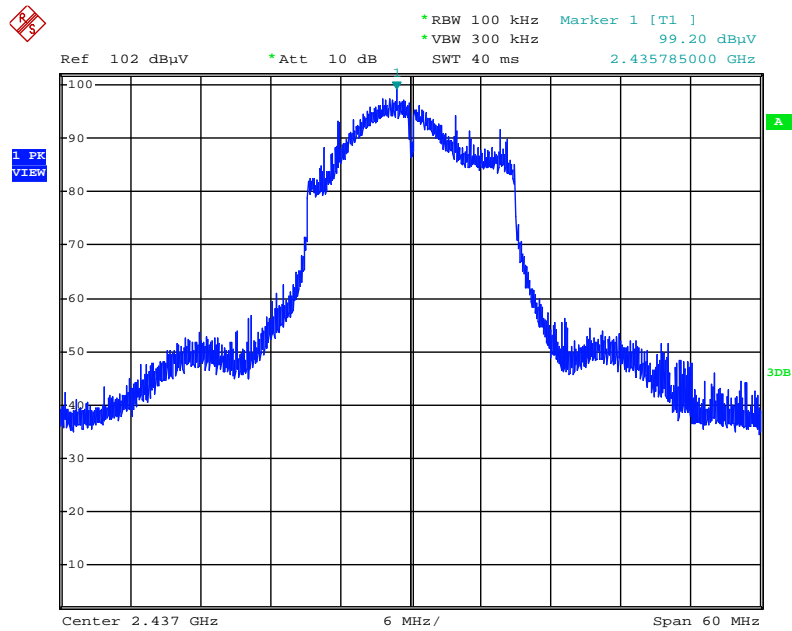

Date: 9.OCT.2015 02:53:20

Plot on Configuration IEEE 802.11n MCS0 HT20 / CH 1 / 30MHz~2400MHz (down 30dBc)

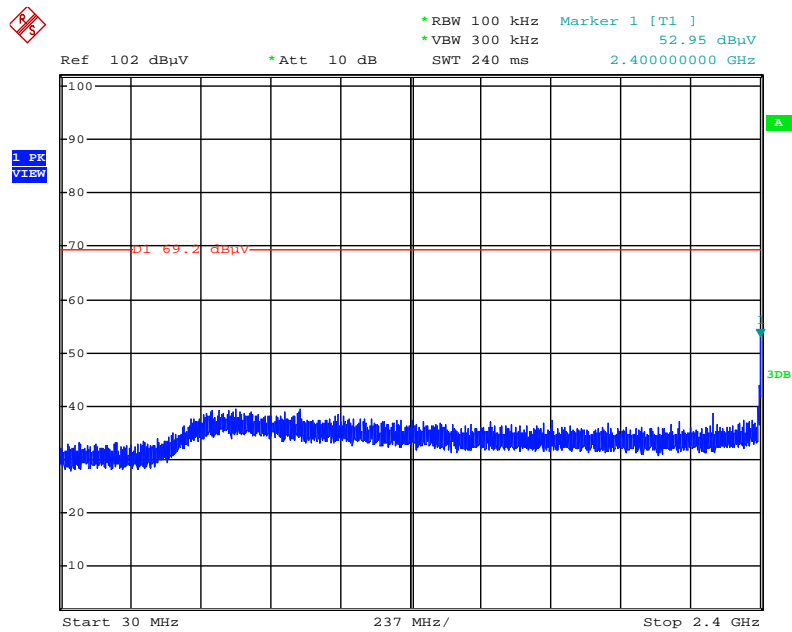

Date: 9.OCT.2015 02:55:20

Plot on Configuration IEEE 802.11n MCS0 HT20 / CH 1 / 2500MHz~26500MHz (down 30dBc)

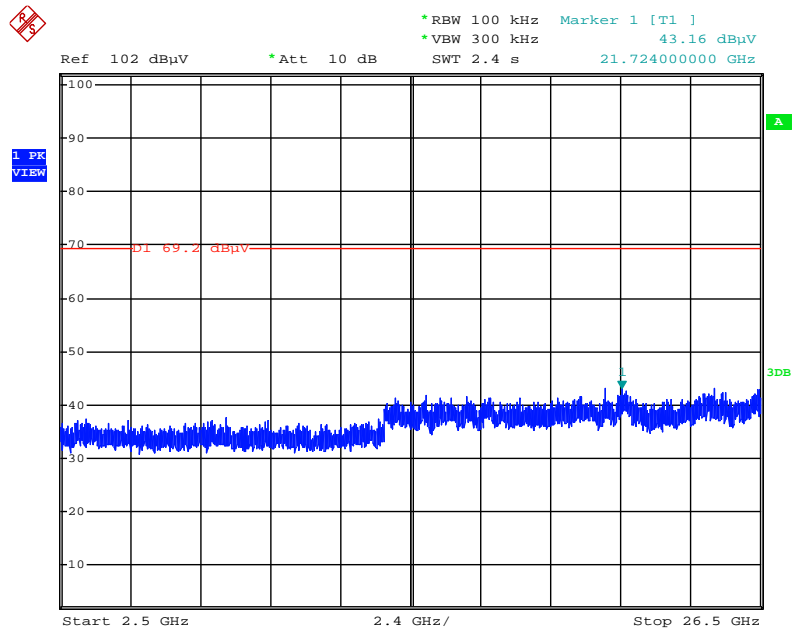

Date: 9.OCT.2015 02:55:51

Plot on Configuration IEEE 802.11n MCS0 HT20 / CH 11 / 30MHz~2400MHz (down 30dBc)

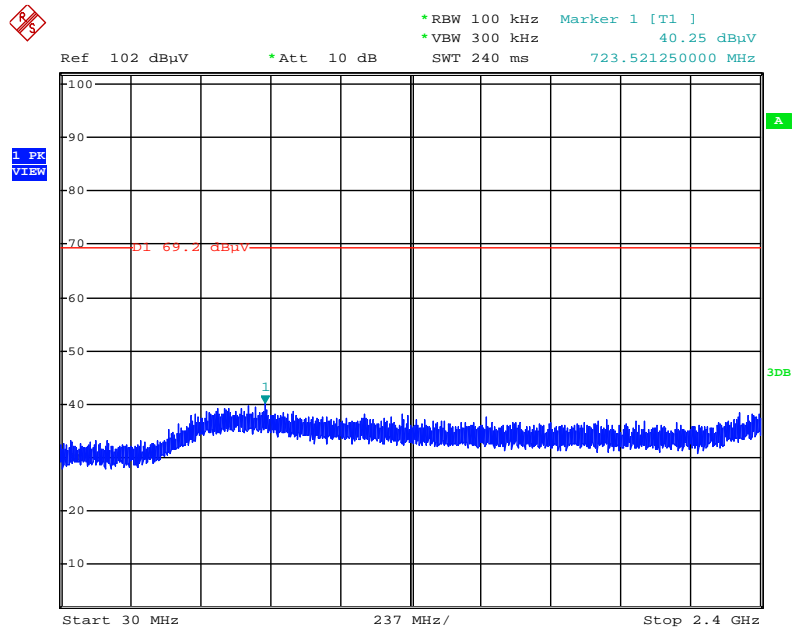

Date: 9.OCT.2015 02:57:52

Plot on Configuration IEEE 802.11n MCS0 HT20 / CH 11 / 2500MHz~26500MHz (down 30dBc)

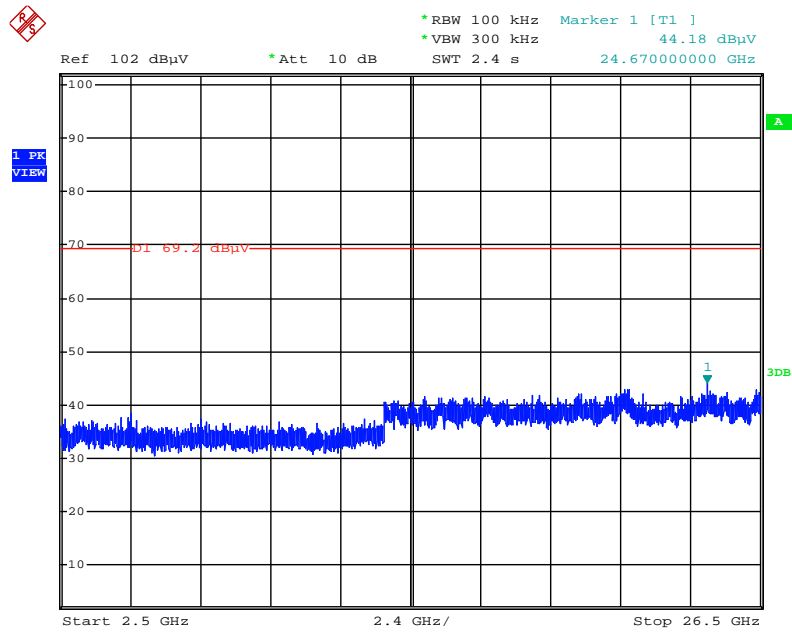

Date: 9.OCT.2015 02:58:44

Plot on Configuration IEEE 802.11n MCS0 HT40 / Reference Level

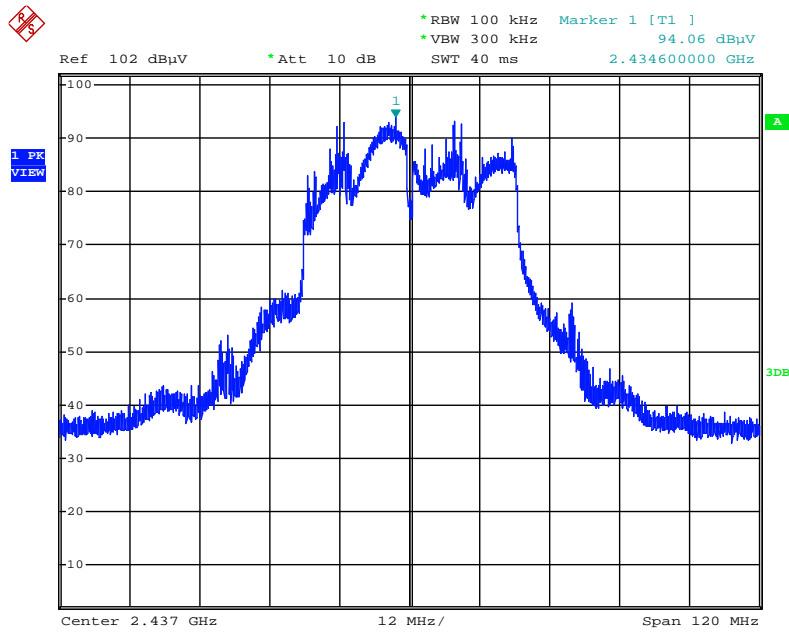

Date: 9.OCT.2015 03:01:24

Plot on Configuration IEEE 802.11n MCS0 HT40 / CH 3 / 30MHz~2400MHz (down 30dBc)

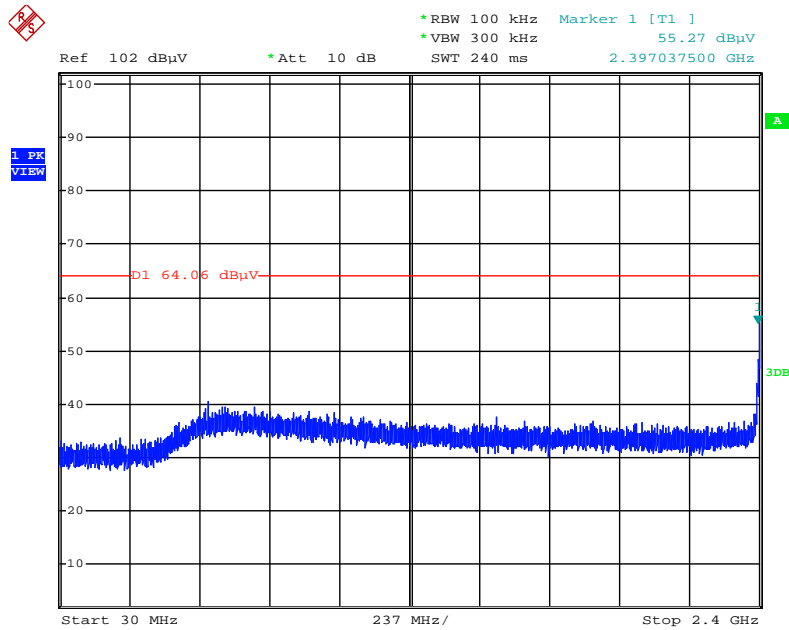

Date: 9.OCT.2015 03:03:06

Plot on Configuration IEEE 802.11n MCS0 HT40 / CH 3 / 2500MHz~26500MHz (down 30dBc)

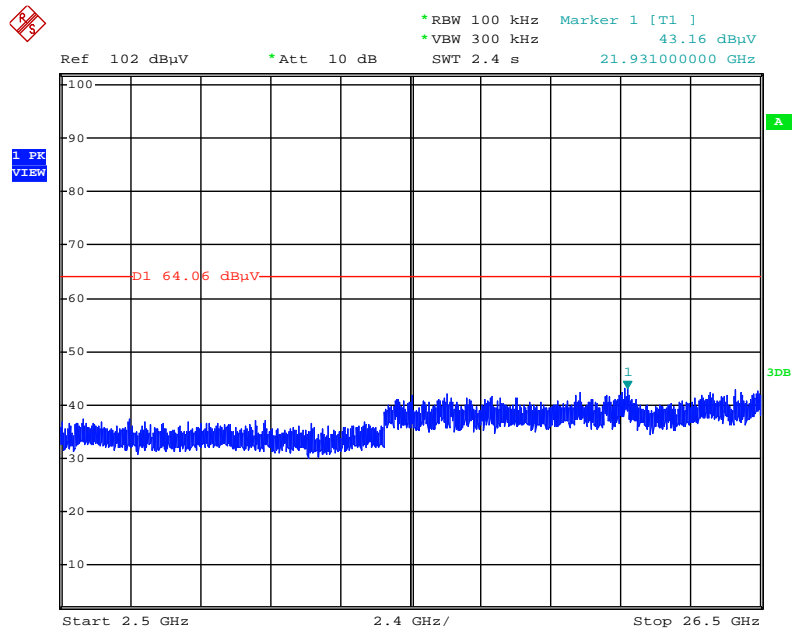

Date: 9.OCT.2015 03:03:32

Plot on Configuration IEEE 802.11n MCS0 HT40 / CH 9 / 30MHz~2400MHz (down 30dBc)

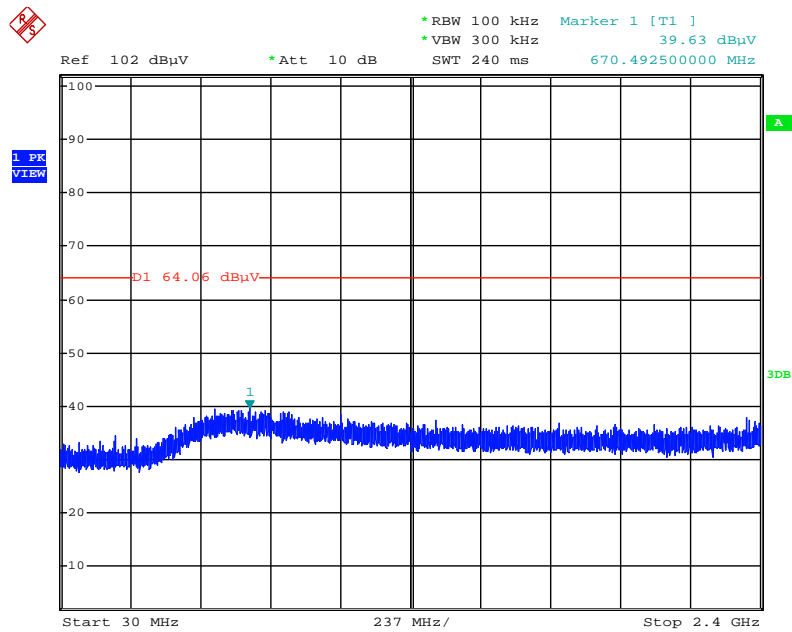

Date: 9.OCT.2015 03:05:00

Plot on Configuration IEEE 802.11n MCS0 HT40 / CH 9 / 2500MHz~26500MHz (down 30dBc)

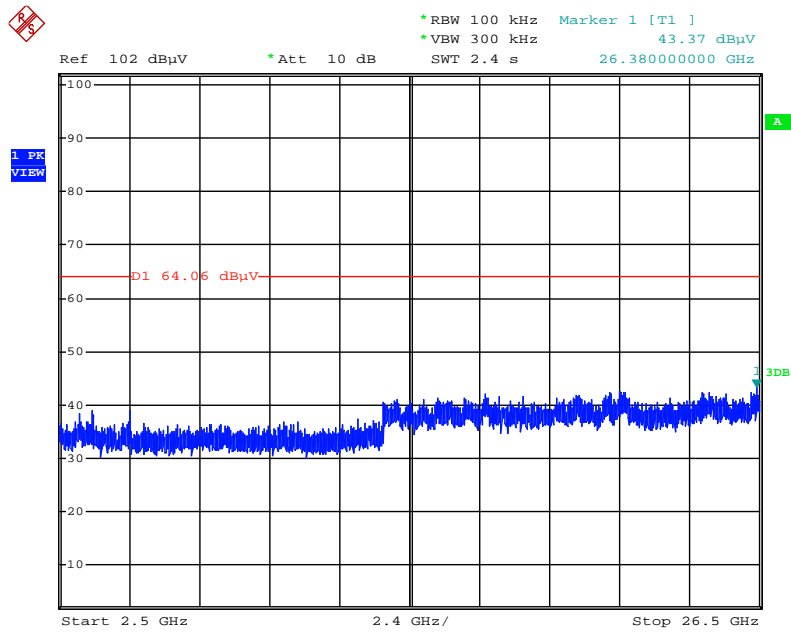

Date: 9.OCT.2015 03:05:24

4.7. Antenna Requirements

4.7.1. Limit

Except for special regulations, the Low-power Radio-frequency Devices must not be equipped with any jacket for installing an antenna with extension cable. An intentional radiator shall be designed to ensure that no antenna other than that furnished by the responsible party shall be used with the device. The use of a permanently attached antenna or of an antenna that uses a unique coupling to the intentional radiator shall be considered sufficient to comply with the provisions of this Section. The manufacturer may design the unit so that the user can replace a broken antenna, but the use of a standard antenna jack or electrical connector is prohibited. Further, this requirement does not apply to intentional radiators that must be professionally installed.

4.7.2. Antenna Connector Construction

Please refer to section 3.3 in this test report; antenna connector complied with the requirements.

5. LIST OF MEASURING EQUIPMENTS

Instrument	Manufacturer	Model No.	Serial No.	Characteristics	Calibration Date	Remark
EMI Test Receiver	R&S	ESCS 30	100355	9kHz ~ 2.75GHz	Apr. 22, 2015	Conduction (CO01-CB)
LISN	F.C.C.	FCC-LISN-50-16-2	04083	150kHz ~ 100MHz	Dec. 02, 2014	Conduction (CO01-CB)
LISN	Schwarzbeck	NSLK 8127	8127647	9kHz ~ 30MHz	Dec. 02, 2014	Conduction (CO01-CB)
COND Cable	Woken	Cable	01	150kHz ~ 30MHz	Dec. 03, 2014	Conduction (CO01-CB)
Software	Audix	E3	6.120210n	-	N.C.R.	Conduction (CO01-CB)
BILOG ANTENNA	Schaffner	CBL6112D	22021	20MHz ~ 2GHz	May 06, 2015	Radiation (O3CH01-CB)
Loop Antenna	Teseq	HLA 6120	24155	9kHz - 30 MHz	Mar. 12, 2015*	Radiation (O3CH01-CB)
Horn Antenna	EMCO	3115	00075790	750MHz ~ 18GHz	Oct. 28, 2014	Radiation (O3CH01-CB)
Horn Antenna	Schwarzbeck	BBHA 9170	BBHA9170252	15GHz ~ 40GHz	Jul. 21, 2015	Radiation (O3CH01-CB)
Pre-Amplifier	Agilent	8447D	2944A10991	0.1MHz ~ 1.3GHz	Feb. 24, 2015	Radiation (O3CH01-CB)
Pre-Amplifier	Agilent	8449B	3008A02310	1GHz ~ 26.5GHz	Jan. 12, 2015	Radiation (O3CH01-CB)
EMI Receiver	Agilent	N9038A	MY52260123	9kHz ~ 8.4GHz	Jan. 21, 2015	Radiation (O3CH01-CB)
Spectrum Analyzer	R&S	FSP40	100056	9kHz ~ 40GHz	Nov. 06, 2014	Radiation (O3CH01-CB)
RF Cable-low	Woken	Low Cable-1	N/A	30 MHz ~ 1 GHz	Nov. 15, 2014	Radiation (O3CH01-CB)
RF Cable-high	Woken	High Cable-40G-1	N/A	1 GHz ~ 40 GHz	Nov. 15, 2014	Radiation (O3CH01-CB)
RF Cable-high	Woken	High Cable-40G-2	N/A	1 GHz ~ 40 GHz	Nov. 15, 2014	Radiation (O3CH01-CB)
Spectrum analyzer	R&S	F5V40	100979	9kHz~40GHz	Dec. 12, 2014	Conducted (TH01-CB)
RF Cable-high	Woken	RG402	High Cable-7	1 GHz – 26.5 GHz	Nov. 15, 2014	Conducted (TH01-CB)
RF Cable-high	Woken	RG402	High Cable-8	1 GHz – 26.5 GHz	Nov. 15, 2014	Conducted (TH01-CB)
RF Cable-high	Woken	RG402	High Cable-9	1 GHz – 26.5 GHz	Nov. 15, 2014	Conducted (TH01-CB)
RF Cable-high	Woken	RG402	High Cable-10	1 GHz – 26.5 GHz	Nov. 15, 2014	Conducted (TH01-CB)
RF Cable-high	Woken	RG402	High Cable-6	1 GHz – 26.5 GHz	Nov. 15, 2014	Conducted (TH01-CB)
Power Sensor	Agilent	U2021XA	MY53410001	50MHz~18GHz	Nov. 03, 2014	Conducted (TH01-CB)

Note: Calibration Interval of instruments listed above is one year.

“*” Calibration Interval of instruments listed above is two years.

N.C.R. means Non-Calibration required.

6. MEASUREMENT UNCERTAINTY

Test Items	Uncertainty	Remark
Conducted Emission (150kHz ~ 30MHz)	3.2 dB	Confidence levels of 95%
Radiated Emission (30MHz ~ 1,000MHz)	3.6 dB	Confidence levels of 95%
Radiated Emission (1GHz ~ 18GHz)	3.7 dB	Confidence levels of 95%
Radiated Emission (18GHz ~ 40GHz)	3.5 dB	Confidence levels of 95%
Conducted Emission	1.7 dB	Confidence levels of 95%