

RF Test Report

Applicant : D-Link Corporation
 Product Name : 5G NR AX3000 Wi-Fi 6 Router
 Trade Name : D-Link
 Model Number : G530, G530/X, G530/XX, G530/XXX (X is A-Z and 0-9)
 Applicable Standard : FCC 47 CFR PART 22H
 FCC 47 CFR PART 24E
 ANSI C63.26 2015
 Received Date : Jan. 23, 2025
 Test Period : Mar. 15, 2025 ~ Mar. 19, 2025
 Issued Date : May 23, 2025

Issued by

Eurofins E&E Wireless Taiwan Co., Ltd.
 No. 140-1, Changan Street, Bade District,
 Taoyuan City, Taiwan (R.O.C.)
 Tel : +886-3-2710188 / Fax : +886-3-2710190



Taiwan Accreditation Foundation accreditation number: 1330
 Frequency Range: 9 kHz to 40 GHz
 Bade test site :
 Test Firm Registration Number: 226252
 Test Firm Designation Number: TW0010
 Wugu test site :
 Test Firm Registration Number: 191812
 Test Firm Designation Number: TW0034

Note:

1. The test results are valid only for samples provided by customers and under the test conditions described in this report.
2. This report shall not be reproduced except in full, without the written approval of Eurofins E&E Wireless Taiwan Co., Ltd.
3. The relevant information is provided by customers in this test report. According to the correctness, appropriateness or completeness of the information provided by the customer, if there is any doubt or error in the information which affects the validity of the test results, the laboratory does not take the responsibility.

Revision History

Rev.	Issued Date	Description	Revised by
00	May 23, 2025	Initial Issue	Snow Wang

Verification of Compliance

Applicant : D-Link Corporation

Product Name : 5G NR AX3000 Wi-Fi 6 Router

Trade Name : D-Link

Model Number : G530, G530/X, G530/XX, G530/XXX (X is A-Z and 0-9)

FCC ID : KA2G530B1

Applicable Standard : FCC 47 CFR PART 22H
FCC 47 CFR PART 24E
ANSI C63.26 2015

Test Result : Complied

Issued By : Eurofins E&E Wireless Taiwan Co., Ltd.
No. 140-1, Changan Street, Bade District,
Taoyuan City, Taiwan (R.O.C.)
Tel : +886-3-2710188 / Fax : +886-3-2710190



Taiwan Accreditation Foundation accreditation number: 1330

Eurofins E&E Wireless Taiwan Co., Ltd. tested the above equipment in accordance with the requirements set forth in the above standards. All indications of Pass/Fail in this report are opinions expressed by Eurofins E&E Wireless Taiwan Co., Ltd. based on interpretations and/or observations of test results. The test results show that the equipment tested is capable of demonstrating compliance with the requirements as documented in this report.

Approved By : _____

TABLE OF CONTENTS

1	General Information	5
1.1.	Summary of Test Result	5
1.2.	Testing Location	5
1.3.	Measurement Uncertainty	6
1.4.	Test Site Environment.....	6
2	EUT Description.....	7
2.1.	Mode of Operation.....	8
2.2.	EUT Test Step	9
2.3.	Configuration of Test System Details.....	9
2.4.	Test Instruments.....	10
3	Measurement Procedure.....	12
3.1.	RF Output Power Test	12
3.2.	Effective Radiated Power / Equivalent Isotropic Radiated Power Test	13
3.3.	Peak to Average Power Ratio Test	16
3.4.	Emission Bandwidth & Occupied Bandwidth Test.....	17
3.5.	Band Edge Test	18
3.6.	Conducted Spurious Emission Test	19
3.7.	Field Strength of Spurious Radiation Test	21
3.8.	Frequency Stability (Temperature & Voltage Variation) Test.....	24
4	Test Results	25
4.1.	Conducted Output Power	26
4.2.	Effective Radiated Power / Equivalent Isotropic Radiated Power Test	28
4.3.	Peak to Average Power Ratio.....	30
4.4.	Emission Bandwidth & Occupied Bandwidth	33
4.5.	Band Edge Measurement.....	36
4.6.	Spurious Emission at Antenna Terminal	38
4.7.	Field Strength of Spurious Radiation	51
4.8.	Frequency Stability for Temperature & Voltage	59

Appendix A. Test Setup Photographs

1 General Information

1.1. Summary of Test Result

FCC Rule	Description	Result
§2.1046	Conducted Output Power	Reference
§22.913(a)(5)	Effective Radiated Power	Pass
§24.232(c)	Equivalent Isotropic Radiated Power	Pass
§24.232(d) KDB 971168 D01 (5.7.1)	Peak to Average Power Ratio	Pass
§2.1049 §22.917(a) §24.238(a)	Emission Bandwidth & Occupied Bandwidth	Reference
§2.1051 §22.917(a) §24.238(a)	Band Edge Measurement	Pass
§2.1051 §22.917(a) §24.238(a)	Conducted Spurious Emission	Pass
§2.1053 §22.917(a) §24.238(a)	Field Strength of Spurious Radiation	Pass
§2.1055 §22.355 §24.235	Frequency Stability for Temperature & Voltage	Pass

Decision Rule

- Uncertainty is not included.
- Uncertainty is included.

1.2. Testing Location

Lab Name: Eurofins E&E Wireless Taiwan Co., Ltd.

Site Address: No. 140-1, Changan Street, Bade District, Taoyuan City, Taiwan (R.O.C.)

Site Address: No. 2, Wuquan 5th Rd. Wugu Dist., New Taipei City, Taiwan (R.O.C.)

1.3. Measurement Uncertainty

Parameter	Uncertainty				
	BD		WG		
Conducted Output Average Power	1.1 dB		1.1 dB		
Effective Radiated Power / Equivalent Isotropic Radiated Power	1.1 dB		1.1 dB		
Frequency Stability	1.3 x 10 ⁻⁷ x fc (Hz)		1.3 x 10 ⁻⁷ x fc (Hz)		
Emission Bandwidth & Occupied Bandwidth	4.4 %		4.4 %		
Peak to Average Power Ratio	1.1 dB		1.1 dB		
Band Edge	1.1 dB		1.1 dB		
Conducted Spurious Emission	1.1 dB		1.1 dB		
Parameter	Uncertainty				
	96601-BD	96603-BD	96602-WG	96603-WG	96604-WG
Radiated Emission	6.3 dB	6.3 dB	6.3 dB	6.3 dB	6.3 dB

1.4. Test Site Environment

Items	Required (IEC 60068-1)	Interval(*)
Temperature (C)	15-35	20-30
Humidity (%RH)	25-75	45-75

(*)The measurement ambient temperature is within this range.

Test Setting Condition		
L.V.	Low Voltage	DC 10.8 V
N.V.	Normal Voltage	DC 12 V
H.V.	High Voltage	DC 13.2 V
L.T.	Low Temperature	0 °C
N.T.	Normal Temperature	+25 °C
H.T.	High Temperature	+40 °C

2 EUT Description

The product specifications of the EUT presented in the report are declared by the manufacturer who shall take full responsibility for the authenticity(except E.R.P. /E.I.R.P., Occupied Bandwidth, Emission Designator).

Applicant	D-Link Corporation 14420 Myford Road Suite 100 Irvine California United States 92606				
Product Name	5G NR AX3000 Wi-Fi 6 Router				
Trade Name	D-Link				
Model Number	G530, G530/X, G530/XX, G530/XXX (X is A-Z and 0-9)				
Difference description of model number	Different model numbers are for market purpose.				
FCC ID	KA2G530B1				
IMEI No.	867626050387822				
Mode	Band	UL Frequency (MHz)	DL Frequency (MHz)	Modulation	
WCDMA(RMC12.2K)/ HSDPA/ HSUPA	II	1852.4 ~ 1907.6	1932.4 ~ 1987.6	QPSK, BPSK	
	V	826.4 ~ 846.6	871.4 ~ 891.6	QPSK, BPSK	
Antenna information	ANT	Model	Type	Max. Gain (dBi)	
	ANT-1	ARY196-3277-007-00	PCB antenna	Band II	2.1
				Band V	1.7
	ANT-2	ARY196-3277-009-00	PCB antenna	Band II	2.3
				Band V	2.3
	ANT-3	ARY196-3277-011-00	PCB antenna	Band II	3.1
Band V				N/A	
ANT-4	ARY196-3277-012-00	PCB antenna	Band II	2.1	
			Band V	N/A	
Operate Temp. Range	0 ~ 40 °C				
EUT Power Rating	DC 12 V, 2.0 A				

Frequency Band	E.R.P. /E.I.R.P. (W)		Occupied Bandwidth (MHz)	Emission Designator
WCDMA/ HSDPA/ HSUPA Band II	0.376	(E.I.R.P.)	4.1501	4M15F9W
WCDMA/ HSDPA/ HSUPA Band V	0.208	(E.R.P.)	4.1431	4M14F9W

Testing Sample No.	
Test Item	Sample Number
Radiation	C251294_A002
Conducted	C251294_A002

2.1. Mode of Operation

In the test report use EUT model: G530 to operate testing.

Eurofins has verified the construction and function in typical operation. All the test modes were carried out with the EUT in normal operation, which was shown in this test report and defined as:

Test Mode
WCDMA Band II Link Mode
WCDMA Band V Link Mode

Note: Regards to the frequency band operation: the lowest, middle and highest frequency of channel were selected to perform the test, then shown on this report.

By preliminary testing and verifying three axis (X, Y and Z) position of EUT transmitted status, it was found that "X axis" position was the worst, then the final test was executed the worst condition and test data were recorded in this report.

2.2. EUT Test Step

1	Setup the EUT shown on "Configuration of Test System Details".
2	Turn on the power of all equipment.

2.3. Configuration of Test System Details

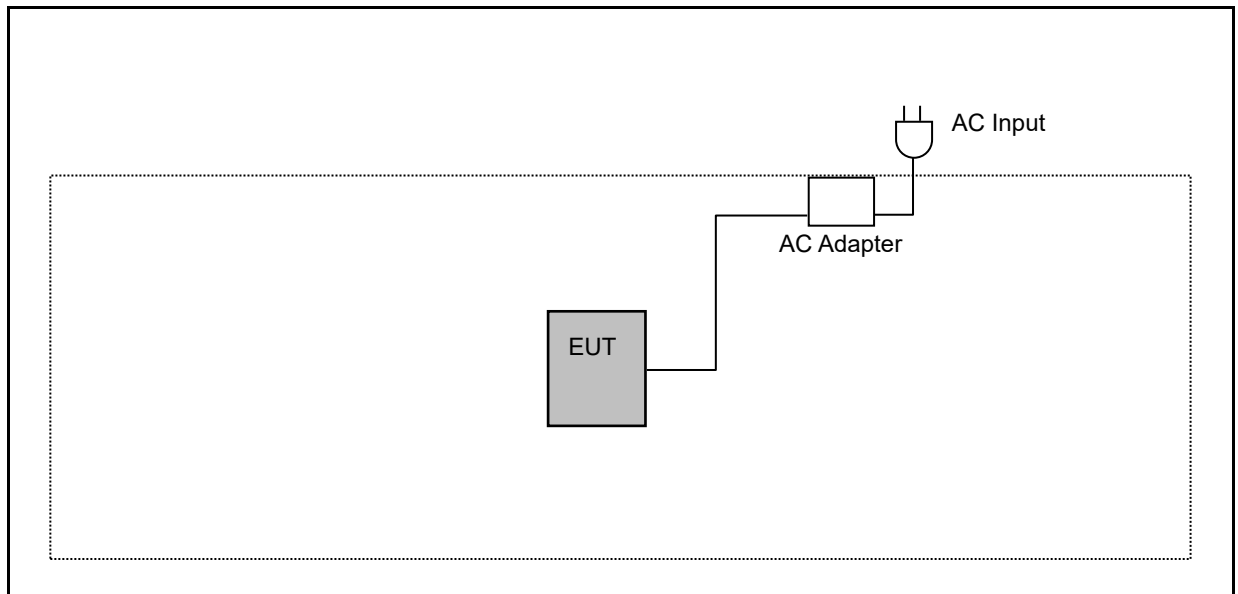

Devices Description					
	Product	Manufacturer	Model Number	Serial Number	Power Cord
(1)	---	---	---	---	---

2.4. Test Instruments

For Conducted

Test Period: Mar. 15, 2025

Testing Engineer: Eric Ou Yang,

Test Site		RF02-BD				
Use	Equipment	Manufacturer	Model Number	Serial Number	Cal. Date	Cal. Period
<input checked="" type="checkbox"/>	Divider	Warison	WDIV-210.5-26.5S20	WR222AM2B2	Aug. 26, 2024	1 year
<input checked="" type="checkbox"/>	Spectrum Analyzer (3 Hz~50 GHz)	Agilent	N9030A	MY53120541	Mar. 07, 2025	1 year
<input checked="" type="checkbox"/>	Universal Radio Communication Tester	R&S	CMU200	112387	Mar. 22, 2024	1 year
<input checked="" type="checkbox"/>	Temperature & Humidity Chamber	TAICHY	MHU-225LA	980729	Mar. 28, 2024	1 year
<input checked="" type="checkbox"/>	Power Supply	IDRC	CP-268	268711	Dec. 19, 2024	1 year

Note: N.C.R. = No Calibration Request

For Radiated Emissions
 Test Period: Mar. 18 ~ Mar. 19, 2025
 Testing Engineer: Jason Yeh

Radiation test sites		Semi Anechoic Room 96603-WG				
Use	Equipment	Manufacturer	Model Number	Serial Number	Cal. Date	Cal. Period
<input checked="" type="checkbox"/>	LOOP Antenna (9 kHz~30 MHz)	Schwarzbeck Mess-Elektronik	FMZB 1513-60	00031	Mar. 06, 2025	1 year
<input checked="" type="checkbox"/>	Trilog Broadband Antenna (30 kHz~1 GHz)	Schwarzbeck Mess-Elektronik	VULB9168	1276	Jan. 20, 2025	1 year
<input checked="" type="checkbox"/>	Broadband Horn Antenna (1 GHz~18 GHz)	RF SPIN	DRH18-E	210307A18ES	Dec. 10, 2024	1 year
<input checked="" type="checkbox"/>	Broadband Horn Antenna (15 GHz~40 GHz)	Schwarzbeck Mess-Elektronik	BBHA9170	1133	Nov. 01, 2024	1 year
<input checked="" type="checkbox"/>	Spectrum Analyzer (2 Hz~50 GHz)	KEYSIGHT	N9030B	MY57153537	Mar. 10, 2025	1 year
<input checked="" type="checkbox"/>	Pre-Amplifier	EMCI	EMC001330	980859	Nov. 27, 2024	1 year
<input checked="" type="checkbox"/>	Pre-Amplifier	EMCI	EMC118A45SE	980818	Dec. 12, 2024	1 year
<input checked="" type="checkbox"/>	Pre-Amplifier	EMCI	EMC184045SE	980861	Dec. 18, 2024	1 year
<input checked="" type="checkbox"/>	Coaxial Cable (10 kHz~3000 MHz)	EMCI	EMCCFD400-NM-NM-2000	211009	Oct. 24, 2024	1 year
<input checked="" type="checkbox"/>	Coaxial Cable (10 kHz~3000 MHz)	EMCI	EMCCFD400-NM-NM-2000	211010	Oct. 24, 2024	1 year
<input checked="" type="checkbox"/>	Coaxial Cable (10 kHz~3000 MHz)	EMCI	EMCCFD400-NM-NM-6000	211018	Oct. 24, 2024	1 year
<input checked="" type="checkbox"/>	Coaxial Cable (1 GHz~18 GHz)	EMCI	EMC104-SM-SM-1000	211029	Oct. 24, 2024	1 year
<input checked="" type="checkbox"/>	Coaxial Cable (1 GHz~18 GHz)	EMCI	EMC104-SM-SM-2000	211033	Oct. 24, 2024	1 year
<input checked="" type="checkbox"/>	Coaxial Cable (1 GHz~18 GHz)	EMCI	EMC104-SM-SM-8000	211038	Oct. 24, 2024	1 year
<input checked="" type="checkbox"/>	Coaxial Cable (18 GHz~40 GHz)	EMCI	EMC101G-KM-KM-600	211211	Jan. 15, 2025	1 year
<input checked="" type="checkbox"/>	Coaxial Cable (18 GHz~40 GHz)	EMCI	EMC101G-KM-KM-2000	211210	Jan. 15, 2025	1 year
<input checked="" type="checkbox"/>	Coaxial Cable (18 GHz~40 GHz)	EMCI	EMC101G-KM-KM-6000	211209	Jan. 15, 2025	1 year
<input checked="" type="checkbox"/>	Highpass Filter	Warison	STI15-9796	001	Oct. 24, 2024	1 year
<input checked="" type="checkbox"/>	Highpass Filter	Warison	WFIL-H3000-20000F	WR4BBFWC2B1	Oct. 24, 2024	1 year
<input checked="" type="checkbox"/>	Highpass Filter	Warison	WFIL-H6000-26500F	WR4BBFWC4B1	Oct. 24, 2024	1 year
<input checked="" type="checkbox"/>	Wireless Test Platform	Keysight	UXM 5G	MY59020225	Mar. 06, 2025	1 year
<input checked="" type="checkbox"/>	Software	R_RAM	V1.3	N/A	N.C.R.	---

Note: N.C.R. = No Calibration Request

3 Measurement Procedure

3.1. RF Output Power Test

- Limit

N/A

- Test Setup

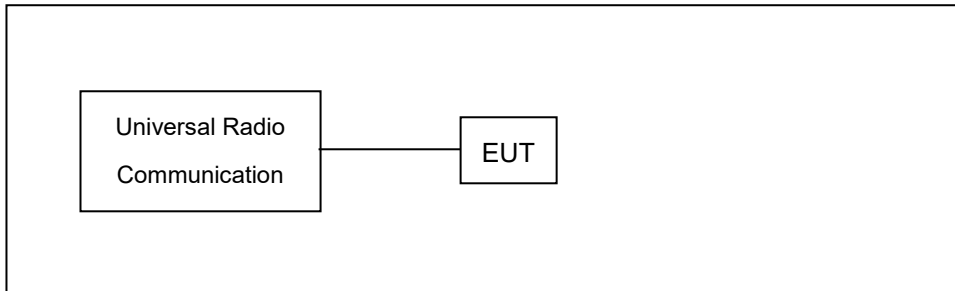

- Test Procedure

- The EUT was set up for the maximum power with simulator.
- Set the EUT to transmit under low, middle and high channel and record the power level shown on simulator.

3.2. Effective Radiated Power / Equivalent Isotropic Radiated Power Test

■ **Limit**

Part 22.913(a)(5): The E.R.P. of mobile transmitters and auxiliary test transmitters must not exceed 7 Watts.

Part 24.232(c): The E.I.R.P. of Mobile and portable stations test transmitters must not exceed 2 Watts.

■ **Setup**

Below 1 GHz

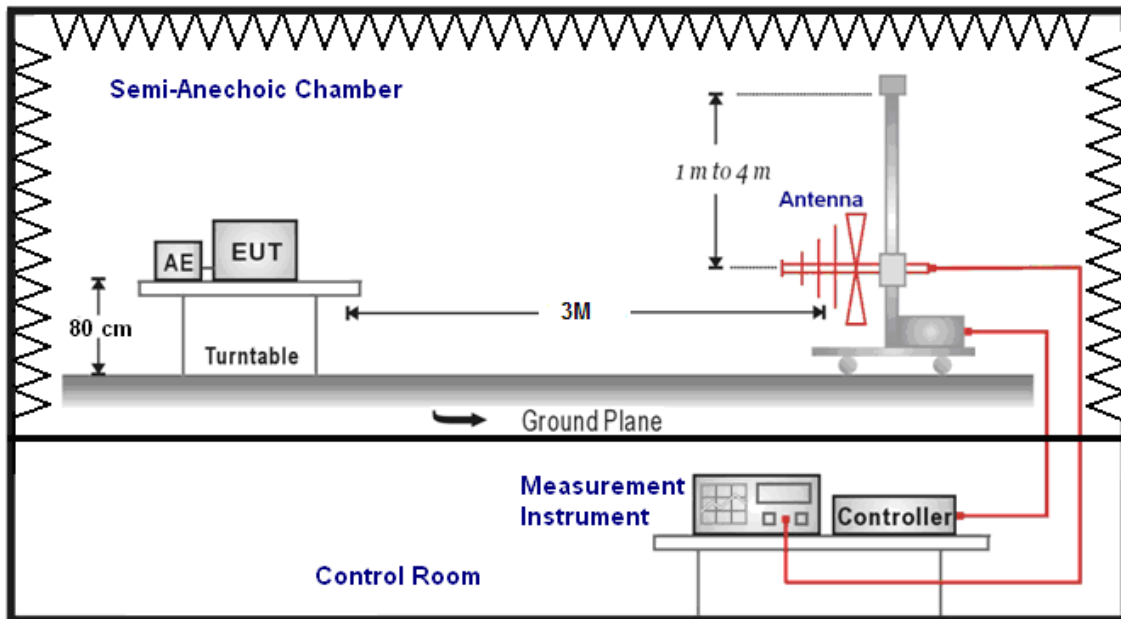

Above 1 GHz

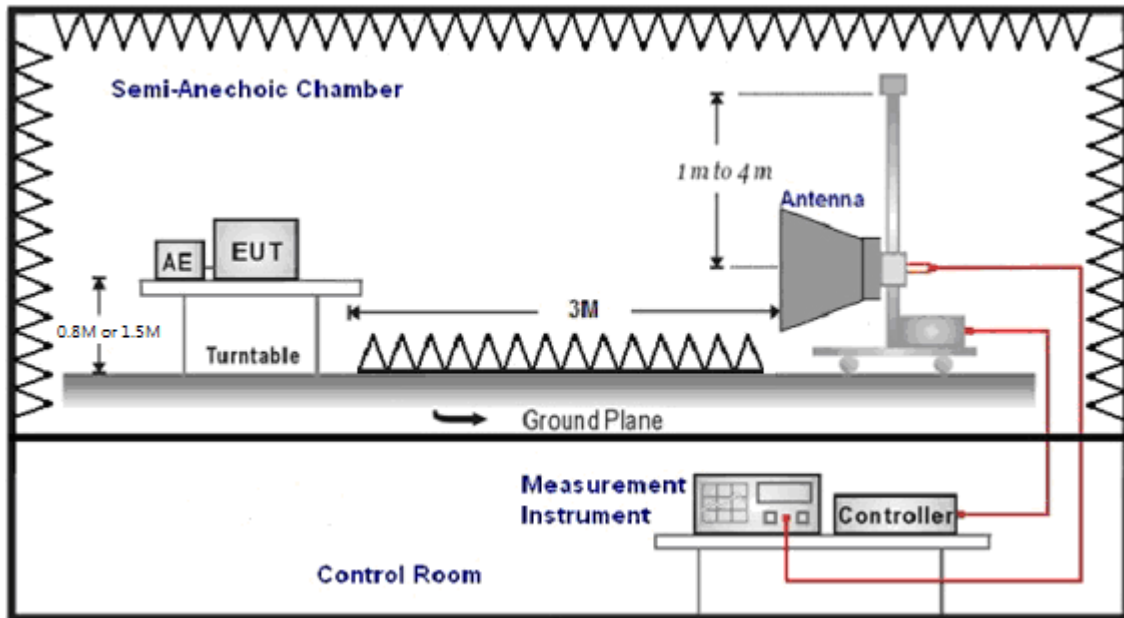

For Substituted Method Test Set-UP

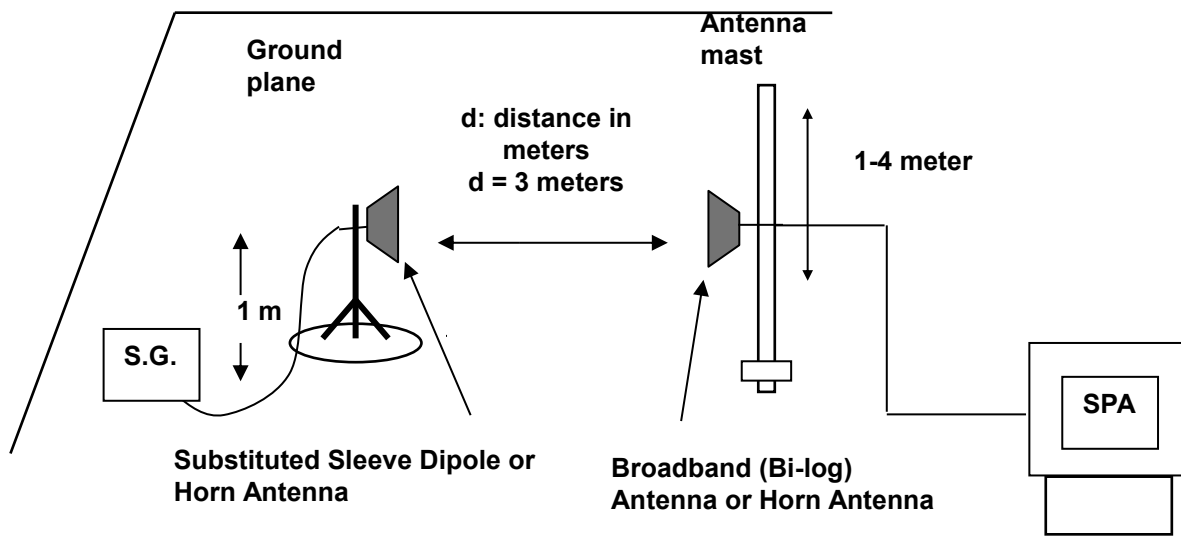

■ **Test Procedure**

- a. The EUT was set up for the maximum power with WWAN link data modulation. The power was measured with Spectrum Analyzer. All measurements were done at 3 channels (low, middle and high operational frequency range).
- b. E.I.R.P power measurement. In the semi-anechoic chamber, EUT placed on the 0.8 m (1.5 m for above 1 GHz) height of Turn Table, rotated the table around 360 degrees to search the maximum radiation power and receiver antenna shall be rotated vertical and horizontal polarization and moved height from 1 m to 4 m to find the maximum polar radiated power. The "Read Value" is the spectrum reading the maximum power value.
- c. The substitution antenna (Note:1 & 2) is substituted for EUT at the same position and signals generator export the CW signal to the substitution antenna via a TX cable. Rotated the Turn Table and moved receiving antenna to find the maximum radiation power. Adjust output power level of S.G to get a Value of spectrum reading equal to "Read Value" of step a. Record the power level of S.G.
- d. E.I.R.P. = Output power level of S.G - TX cable loss + Antenna gain of substitution horn
- e. E.R.P. = E.I.R.P.- 2.15 dB

Note: 1. Below 1 GHz Substituted Method Test : Sleeve dipole antenna to Bi-Log Antenna

2. Above 1 GHz Substituted Method Test : Horn antenna to Horn Antenna

3.3. Peak to Average Power Ratio Test

■ Limit

In measuring transmissions in this band using an average power technique, the peak to-average power ratio (PAPR) of the transmission may not exceed 13 dB.

■ Setup

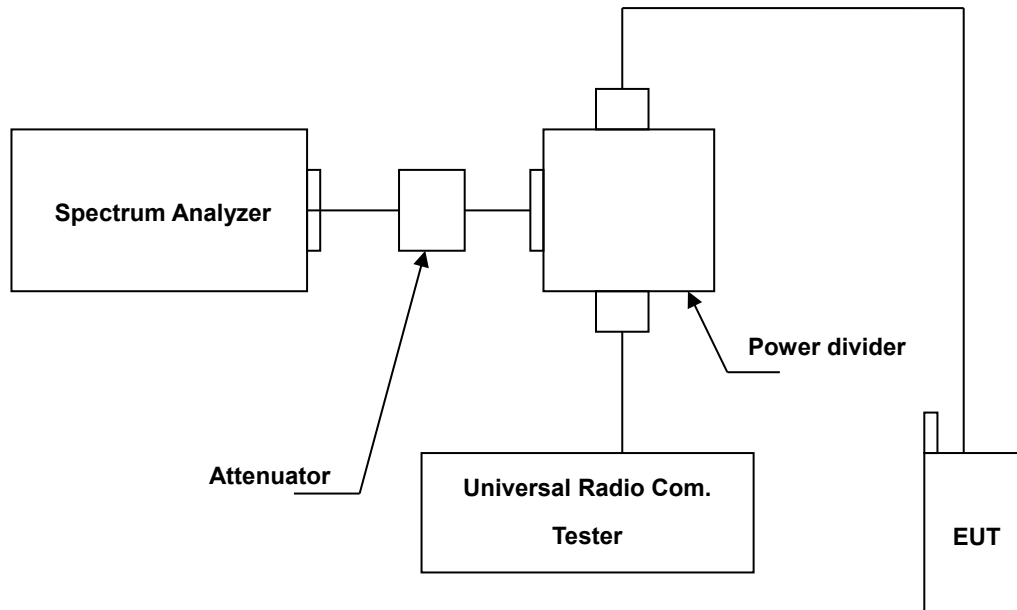

■ Test Procedure

- a. Set resolution/measurement bandwidth signal's occupied bandwidth;
- b. Set the number of counts to a value that stabilizes the measured CCDF curve;
- c. Record the maximum PAPR level associated with a probability of 0.1 %.

3.4. Emission Bandwidth & Occupied Bandwidth Test

■ **Limit**

The Occupied Bandwidth Limit:

N/A.

■ **Setup**

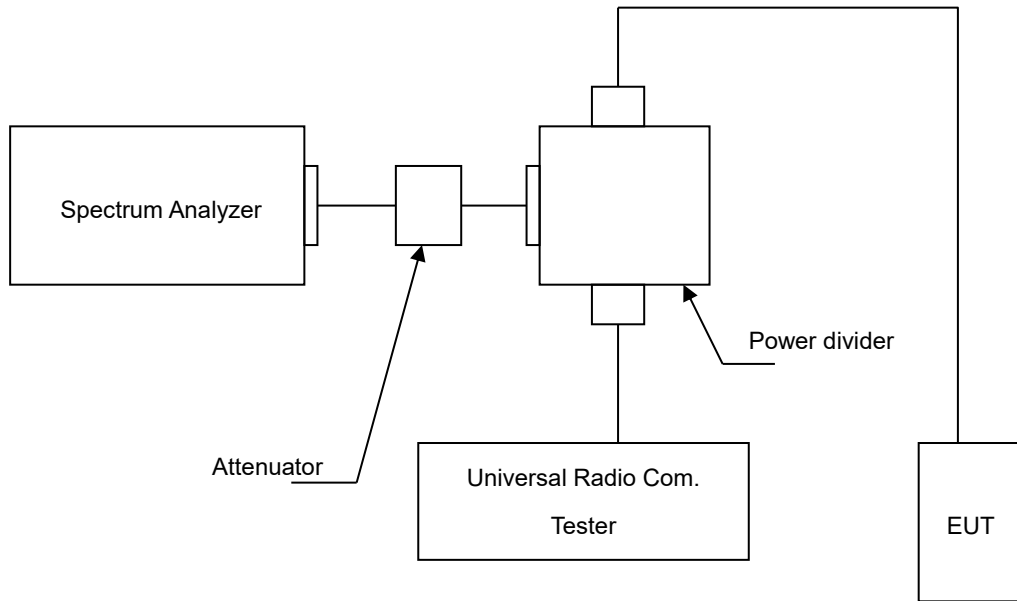

■ **Test Procedure**

1. The EUT was connected to Spectrum Analyzer and Base Station via Power Divider.
2. The occupied bandwidth of middle channel for the highest and lowest RF powers was measured.

3.5. Band Edge Test

■ **Limit**

The Band Edge Limit:

The power of any emission outside of the authorized operating frequency ranges must be attenuated below the transmitting power (P) by a factor of at least $43 + 10 \log(P)$ dB.

■ **Setup**

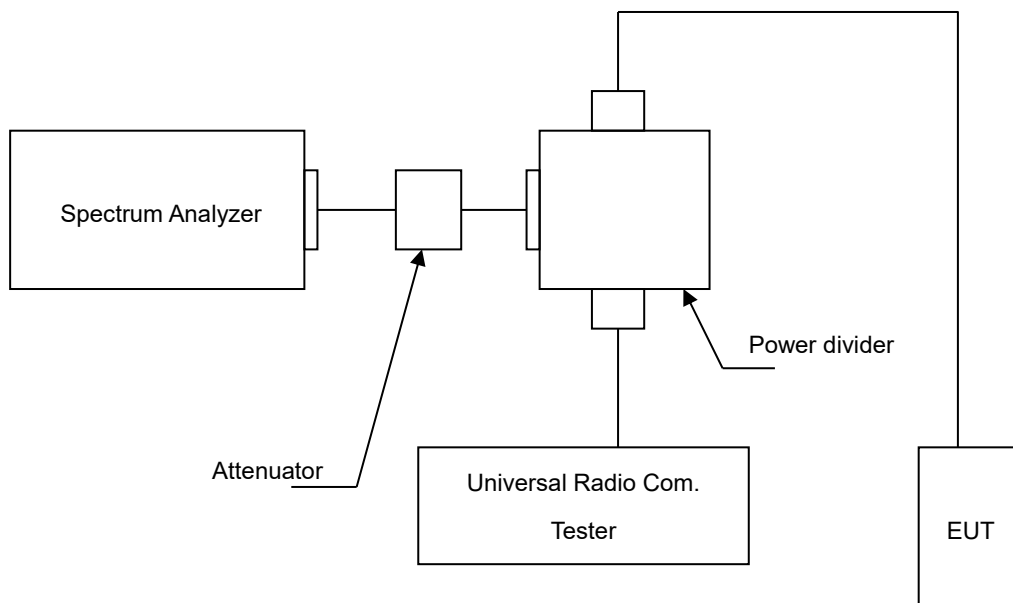

■ **Test Procedure**

1. The EUT was connected to Spectrum Analyzer and Base Station via Power Divider.
2. The band edge of low and high channels for the highest RF powers within the transmitting frequency band were measured.

3.6. Conducted Spurious Emission Test

■ **Limit**

The power of any emission outside of the authorized operating frequency ranges must be attenuated below the transmitting power (P) by a factor of at least $43 + 10 \log(P)$ dB.

■ **Setup**

Below 2.8 GHz

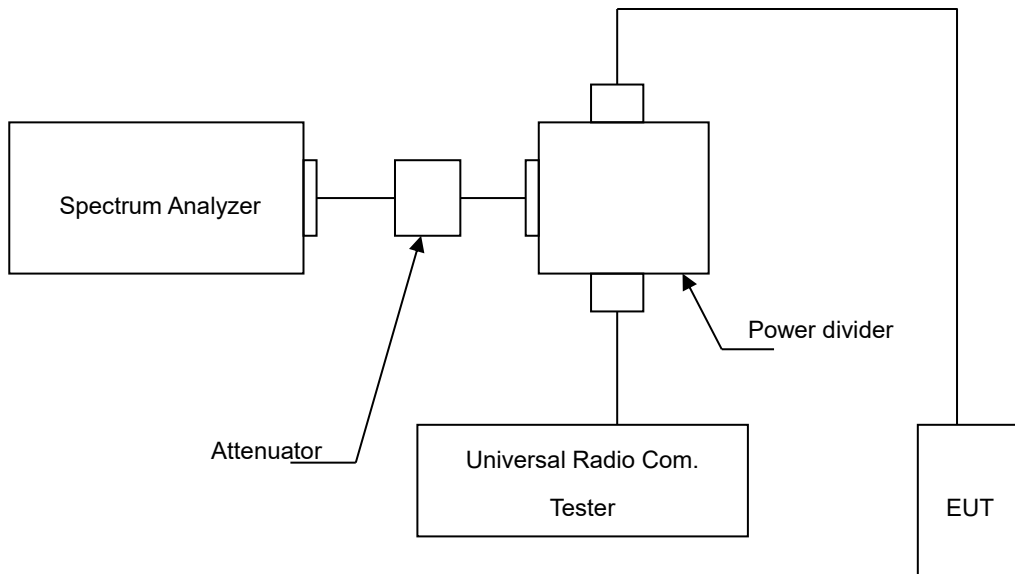

Above 2.8 GHz

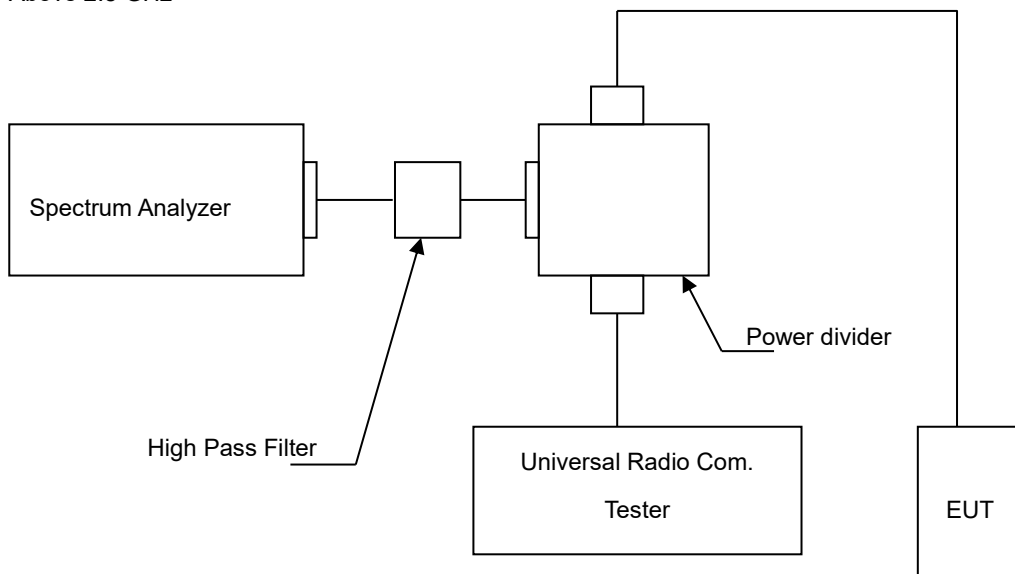

■ Test Procedure

1. The EUT was connected to Spectrum Analyzer and Base Station via Power Divider.
2. The middle channel for the highest RF power within the transmitting frequency was measured.
3. The conducted spurious emission for the whole frequency range was taken.
4. Test setting at WCDMA RB=1 MHz, VB=3 MHz.

3.7. Field Strength of Spurious Radiation Test

■ **Limit**

The power of any emission outside of the authorized operating frequency ranges must be attenuated below the transmitting power (P) by a factor of at least $43 + 10 \log(P)$ dB.

It is measured by means of a calibrated spectrum analyzer and scanned from 9 kHz up to a frequency including its 10th harmonic.

■ **Setup**

Below 1 GHz

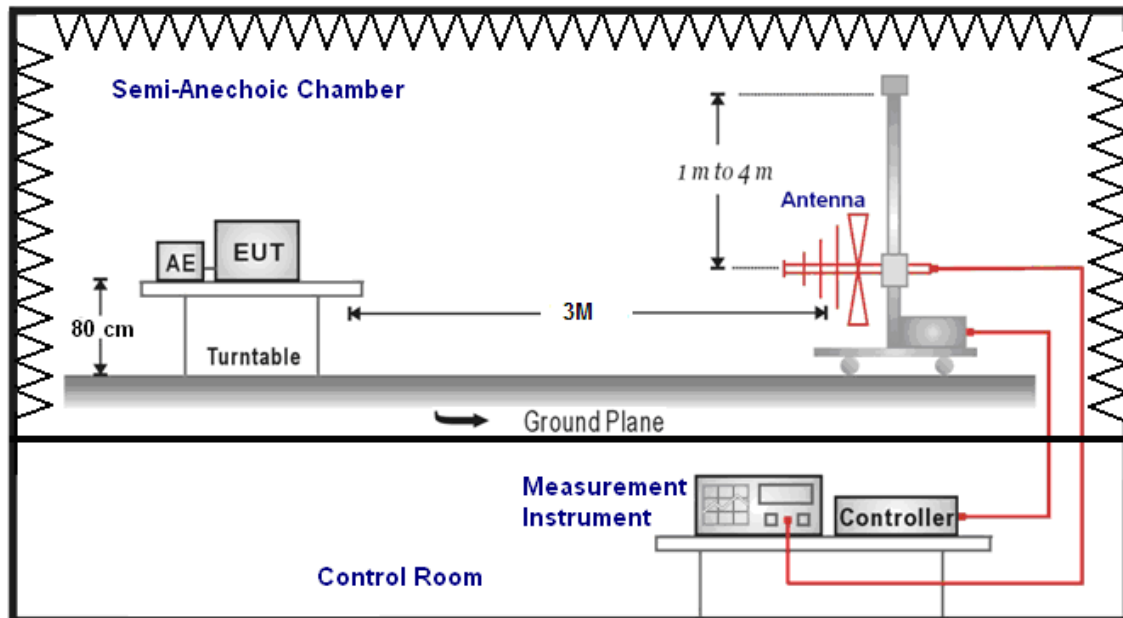

Above 1 GHz

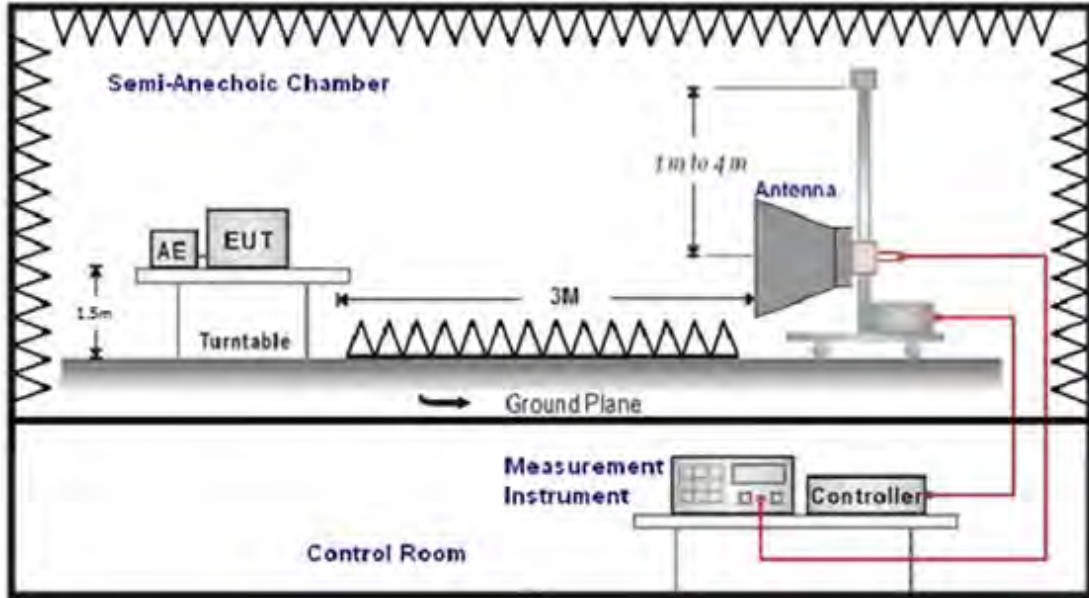

For Substituted Method Test Set-UP

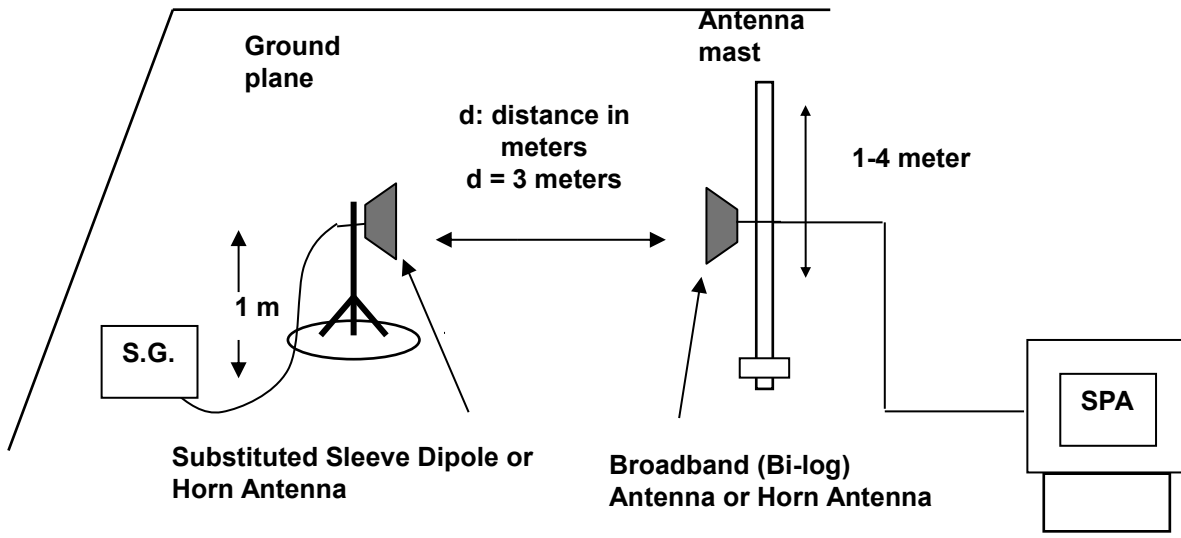

■ **Test Procedure**

- a. The EUT was set up for the maximum power with WWAN link data modulation. The power was measured with Spectrum Analyzer. All measurements were done at 3 channels (low, middle and high operational frequency range).
- b. E.I.R.P power measurement. In the semi-anechoic chamber, EUT placed on the 0.8 m (1.5 m for above 1 GHz) height of Turn Table, rotated the table around 360 degrees to search the maximum radiation power and receiver antenna shall be rotated vertical and horizontal polarization and moved height from 1 m to 4 m to find the maximum polar radiated power. The "Read Value" is the spectrum reading the maximum power value.
- c. The substitution antenna (Note:1 & 2) is substituted for EUT at the same position and signals generator export the CW signal to the substitution antenna via a TX cable. Rotated the Turn Table and moved receiving antenna to find the maximum radiation power. Adjust output power level of S.G to get a Value of spectrum reading equal to "Read Value" of step a. Record the power level of S.G.
- d. E.I.R.P. = Output power level of S.G - TX cable loss + Antenna gain of substitution horn
- e. E.R.P. = E.I.R.P.- 2.15 dB
- f. Measurement range 9 kHz - 10th Harmonic

- Note: 1. Below 1 GHz Substituted Method Test : Sleeve dipole antenna to Bi-Log Antenna
2. Above 1 GHz Substituted Method Test : Horn antenna to Horn Antenna

3.8. Frequency Stability (Temperature & Voltage Variation) Test

■ Limit

The frequency stability shall be measured by variation of ambient temperature and variation of primary supply voltage to ensure that the fundamental emission stays within the authorized frequency block. The frequency stability of the transmitter shall be maintained within $\pm 0.00015\%$ (± 1.5 ppm) of the center frequency.

■ Setup

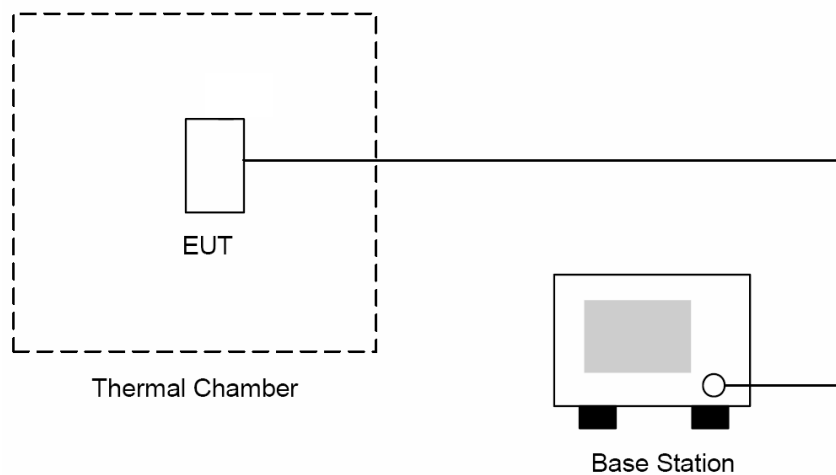

■ Test Procedure

1. The EUT and test equipment were set up as shown on the following section.
2. With all power removed, the temperature was decreased to $-30\text{ }^{\circ}\text{C}$ and permitted to stabilize for three hours. Power was applied and the maximum change in frequency was note within one minute.
3. With power OFF, the temperature was raised in $10\text{ }^{\circ}\text{C}$ steps. The sample was permitted to stabilize at each step for at least one-half hour. Power was applied and the maximum frequency change was noted within one minute.
4. The EUT was placed in a temperature chamber at $25 \pm 5\text{ }^{\circ}\text{C}$ and connected as the following section.
5. The power supply voltage to the EUT was varied from BEP to 115 % of the nominal value measured at the input to the EUT.
6. The temperature tests were performed for the worst case.
7. Test data was recorded.

4 Test Results

Test Mode	Test Modes description
UMTS/TM1	WCDMA system, RMC12.2K modulation
UMTS/TM2	HSDPA system, QPSK modulation
UMTS/TM3	HSUPA system, QPSK modulation

4.1. Conducted Output Power

Bands	Modulation Type	Sub-Test	Frequency (MHz)	Burst Average Power	Peak Power
				(dBm)	(dBm)
WCDMA Band II	RMC12.2K	----	1852.4	23.65	26.84
			1880.0	23.61	26.81
			1907.6	23.56	26.82
HSDPA Band II	QPSK	1	1852.4	22.89	26.39
			1880.0	22.84	26.14
			1907.6	22.77	26.13
		2	1852.4	22.72	26.05
			1880.0	22.66	25.91
			1907.6	22.55	25.84
		3	1852.4	22.36	25.76
			1880.0	22.29	25.56
			1907.6	22.21	25.65
		4	1852.4	22.33	25.68
			1880.0	22.27	25.59
			1907.6	22.23	25.68
HSUPA Band II	QPSK	1	1852.4	22.10	25.49
			1880.0	22.03	25.30
			1907.6	21.95	25.42
		2	1852.4	20.12	23.42
			1880.0	20.01	23.25
			1907.6	19.94	23.39
		3	1852.4	21.14	24.54
			1880.0	21.05	24.45
			1907.6	20.98	24.28
		4	1852.4	20.05	23.27
			1880.0	20.02	23.48
			1907.6	19.93	23.31
		5	1852.4	21.97	25.33
			1880.0	21.88	25.26
			1907.6	21.79	25.02

Note: The peak power testing result was used peak detector.

Bands	Modulation Type	Sub-Test	Frequency (MHz)	Burst Average Power	Peak Power
				(dBm)	(dBm)
WCDMA Band V	RMC12.2K	-----	826.4	23.64	27.11
			836.6	23.59	26.97
			846.6	23.62	27.00
HSDPA Band V	QPSK	1	826.4	22.88	26.29
			836.6	22.77	26.19
			846.6	22.76	26.02
		2	826.4	22.72	26.26
			836.6	22.62	25.91
			846.6	22.62	26.03
		3	826.4	22.33	25.80
			836.6	22.25	25.53
			846.6	22.25	25.58
		4	826.4	22.32	25.65
			836.6	22.23	25.58
			846.6	22.23	25.62
HSUPA Band V	QPSK	1	826.4	22.05	25.33
			836.6	21.95	25.15
			846.6	21.92	25.38
		2	826.4	20.07	23.51
			836.6	19.96	23.34
			846.6	19.95	23.44
		3	826.4	21.03	24.34
			836.6	20.92	24.40
			846.6	20.91	24.35
		4	826.4	20.03	23.26
			836.6	19.91	23.26
			846.6	19.87	23.20
		5	826.4	21.87	25.19
			836.6	21.76	25.12
			846.6	21.70	25.15

Note: The peak power testing result was used peak detector.

4.2. Effective Radiated Power / Equivalent Isotropic Radiated Power Test

Band	Modulation	Test Mode	Frequency (MHz)	Avg Conducted power (dBm)	E.I.R.P.		Limit (W)
					(dBm)	(W)	
WCDMA II	RMC12.2K	---	1852.4	23.65	25.75	0.376	≤2
			1880.0	23.61	25.71	0.372	≤2
			1907.6	23.56	25.66	0.368	≤2
HSDPA II	QPSK	1	1852.4	22.89	24.99	0.316	≤2
			1880.0	22.84	24.94	0.312	≤2
			1907.6	22.77	24.87	0.307	≤2
		2	1852.4	22.72	24.82	0.303	≤2
			1880.0	22.66	24.76	0.299	≤2
			1907.6	22.55	24.65	0.292	≤2
		3	1852.4	22.36	24.46	0.279	≤2
			1880.0	22.29	24.39	0.275	≤2
			1907.6	22.21	24.31	0.270	≤2
		4	1852.4	22.33	24.43	0.277	≤2
			1880.0	22.27	24.37	0.274	≤2
			1907.6	22.23	24.33	0.271	≤2
HSUPA II	QPSK	1	1852.4	22.10	24.20	0.263	≤2
			1880.0	22.03	24.13	0.259	≤2
			1907.6	21.95	24.05	0.254	≤2
		2	1852.4	20.12	22.22	0.167	≤2
			1880.0	20.01	22.11	0.163	≤2
			1907.6	19.94	22.04	0.160	≤2
		3	1852.4	21.14	23.24	0.211	≤2
			1880.0	21.05	23.15	0.207	≤2
			1907.6	20.98	23.08	0.203	≤2
		4	1852.4	20.05	22.15	0.164	≤2
			1880.0	20.02	22.12	0.163	≤2
			1907.6	19.93	22.03	0.160	≤2
		5	1852.4	21.97	24.07	0.255	≤2
			1880.0	21.88	23.98	0.250	≤2
			1907.6	21.79	23.89	0.245	≤2

Band	Modulation	Test Mode	Frequency (MHz)	Avg Conducted power (dBm)	E.R.P.		Limit (W)
					(dBm)	(W)	
WCDMA V	RMC12.2K	---	826.4	23.64	25.34	23.19	≤7
			836.6	23.59	25.29	23.14	≤7
			846.6	23.62	25.32	23.17	≤7
HSDPA V	QPSK	1	826.4	22.88	24.58	22.43	≤7
			836.6	22.77	24.47	22.32	≤7
			846.6	22.76	24.46	22.31	≤7
		2	826.4	22.72	24.42	22.27	≤7
			836.6	22.62	24.32	22.17	≤7
			846.6	22.62	24.32	22.17	≤7
		3	826.4	22.33	24.03	21.88	≤7
			836.6	22.25	23.95	21.80	≤7
			846.6	22.25	23.95	21.80	≤7
		4	826.4	22.32	24.02	21.87	≤7
			836.6	22.23	23.93	21.78	≤7
			846.6	22.23	23.93	21.78	≤7
HSUPA V	QPSK	1	826.4	22.05	23.75	21.60	≤7
			836.6	21.95	23.65	21.50	≤7
			846.6	21.92	23.62	21.47	≤7
		2	826.4	20.07	21.77	19.62	≤7
			836.6	19.96	21.66	19.51	≤7
			846.6	19.95	21.65	19.50	≤7
		3	826.4	21.03	22.73	20.58	≤7
			836.6	20.92	22.62	20.47	≤7
			846.6	20.91	22.61	20.46	≤7
		4	826.4	20.03	21.73	19.58	≤7
			836.6	19.91	21.61	19.46	≤7
			846.6	19.87	21.57	19.42	≤7
		5	826.4	21.87	23.57	21.42	≤2
			836.6	21.76	23.46	21.31	≤2
			846.6	21.70	23.40	21.25	≤2

4.3. Peak to Average Power Ratio

Band	Channel	Peak-to-Average Ratio(dB)	Limit(dBm)	Verdict
Band2	9262	2.83	13	PASS
Band2	9400	2.94	13	PASS
Band2	9538	2.7	13	PASS
Band5	4132	2.98	13	PASS
Band5	4182	2.98	13	PASS
Band5	4233	3.0	13	PASS

Test Graphs

Band2-9262



Band2-9400



Band2-9538



Band5-4132



Band5-4182



Band5-4233



4.4. Emission Bandwidth & Occupied Bandwidth

Band	Channel	Occupied Bandwidth (kHz)	26dB Bandwidth (kHz)	Limit(kHz)	Verdict
Band2	9262	4.1477	4.712	---	PASS
Band2	9400	4.1424	4.699	---	PASS
Band2	9538	4.1501	4.726	---	PASS
Band5	4132	4.1392	4.698	---	PASS
Band5	4182	4.1431	4.698	---	PASS
Band5	4233	4.1322	4.695	---	PASS

Test Graphs



Band5-4132

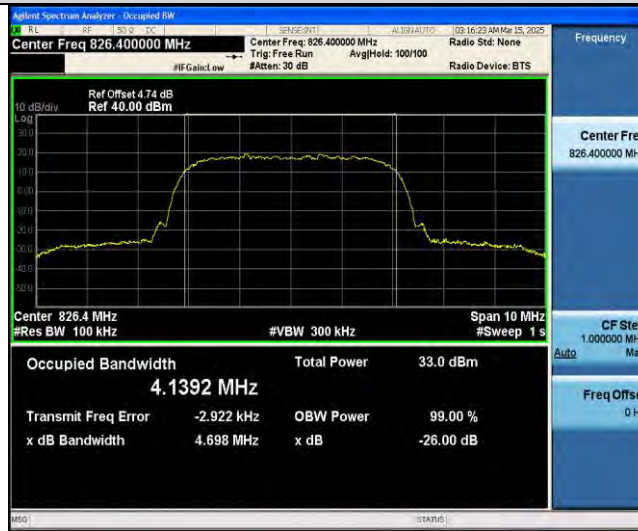

Band5-4182



Band5-4233

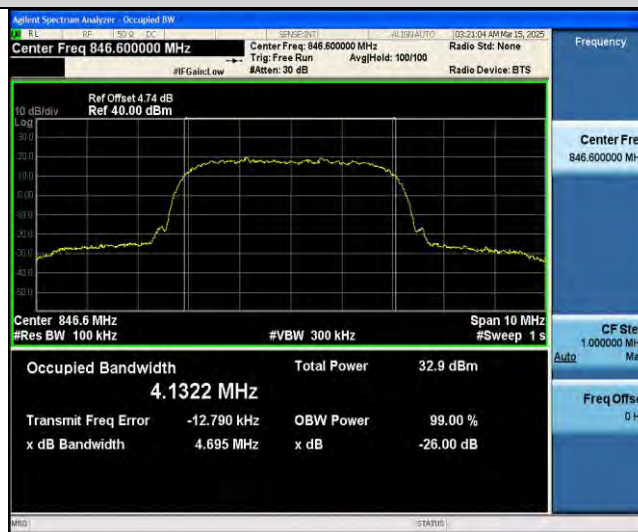

4.5. Band Edge Measurement

■ Test Graphs

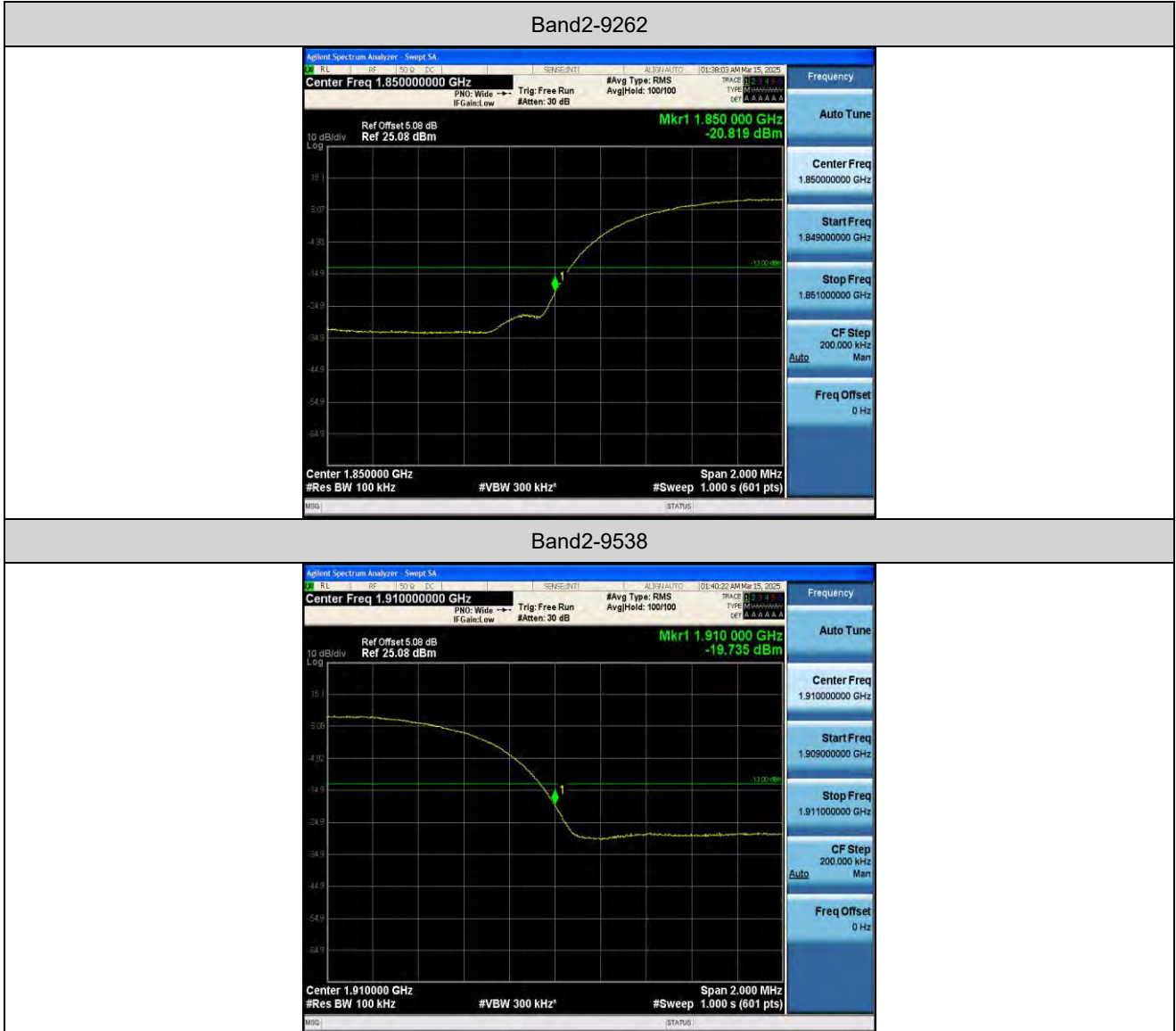

Band5-4132



Band5-4233



4.6. Spurious Emission at Antenna Terminal

■ Test Graphs

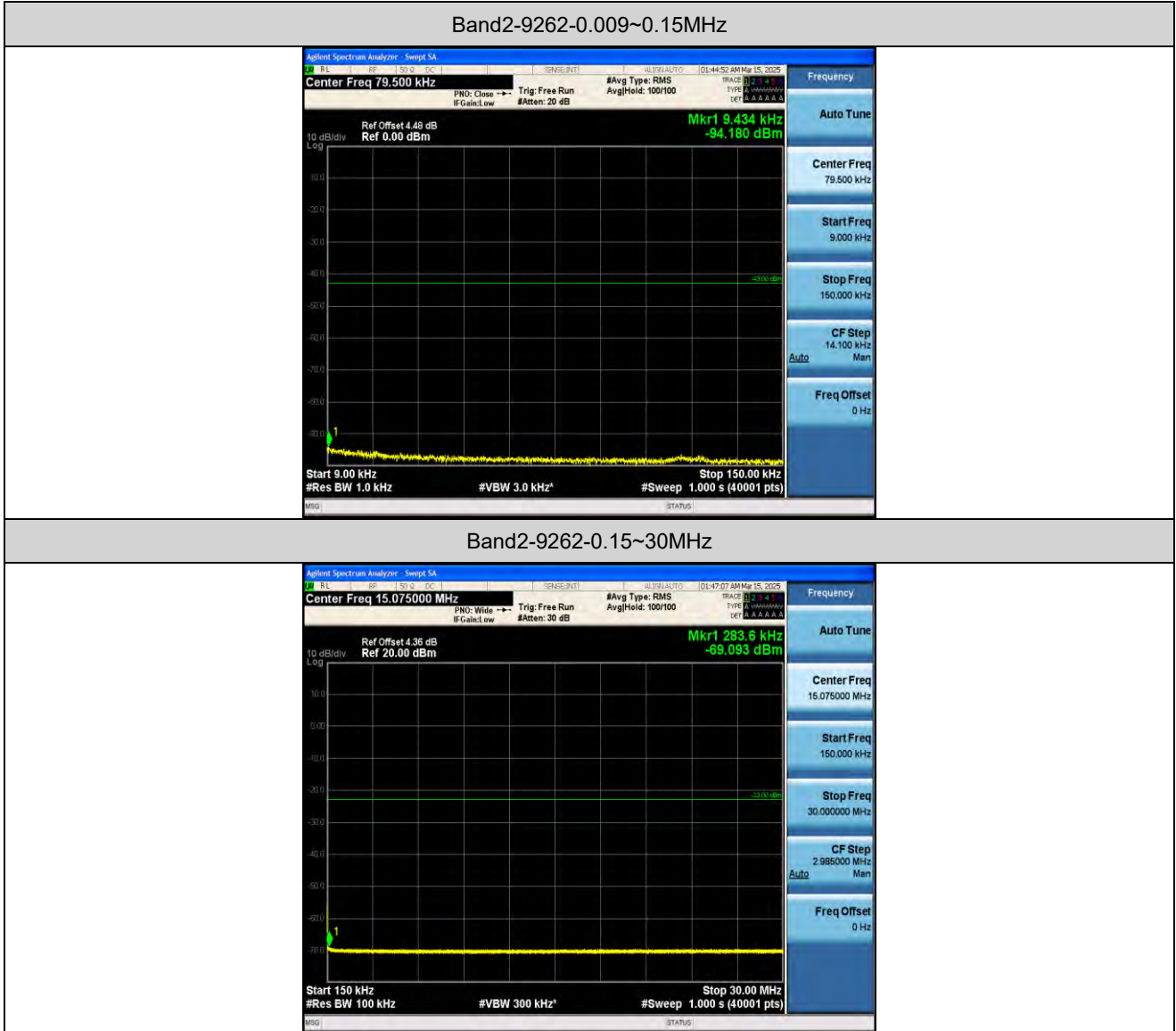

Band2-9262-30~1000MHz

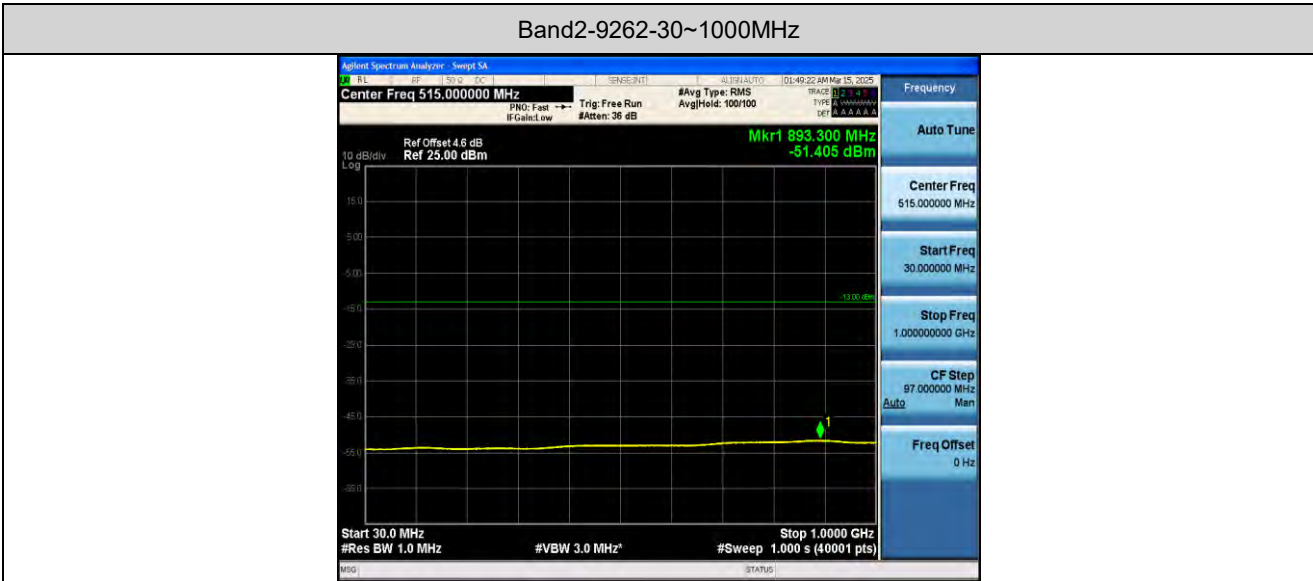

Band2-9262-1000~3000MHz



Band2-9262-3000~10000MHz

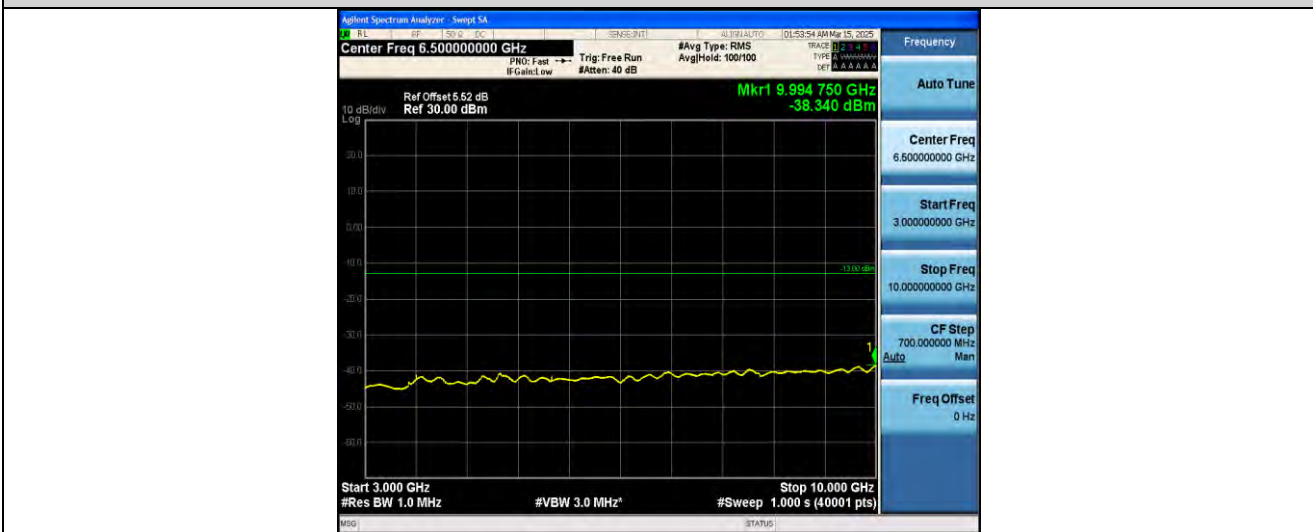

Band2-9262-1000~2000MHz

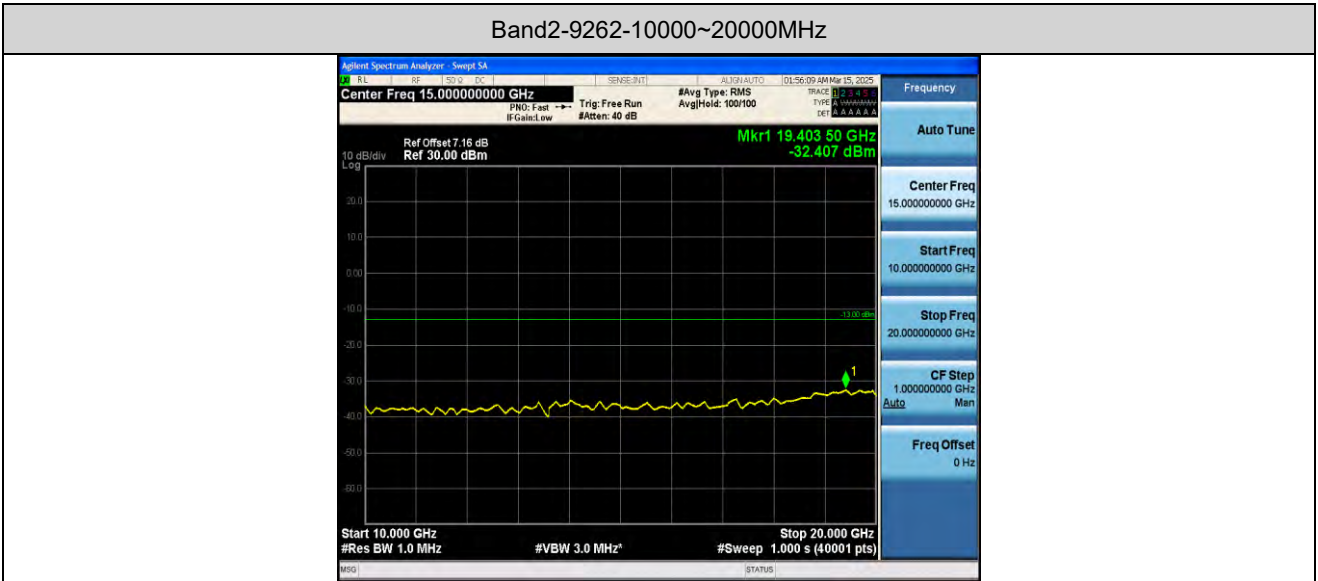

Band2-9400-0.009~0.15MHz

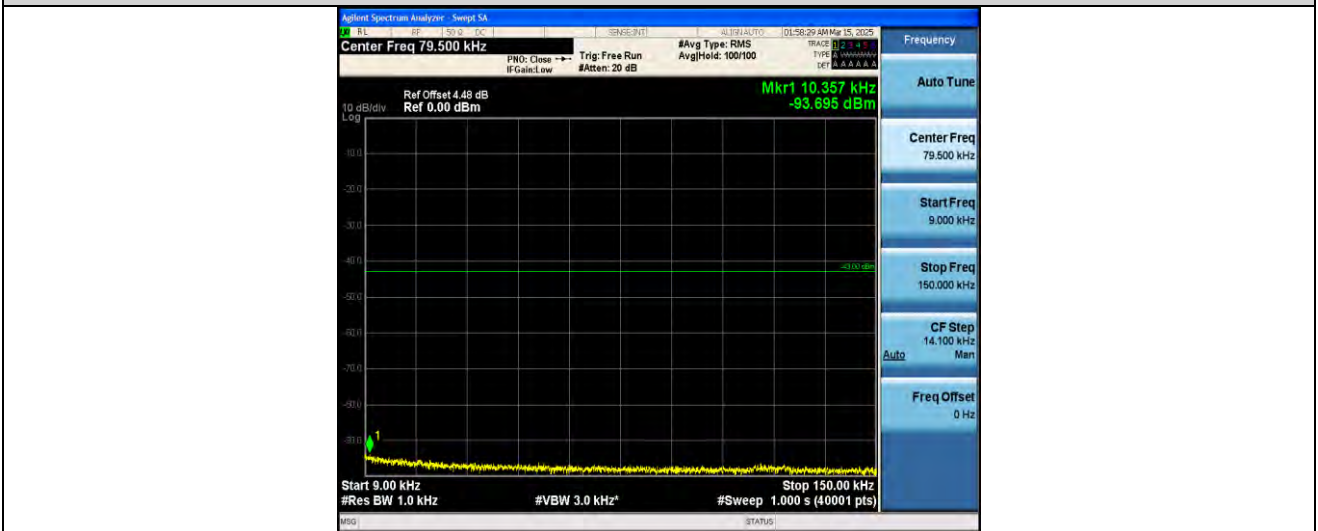

Band2-9400-0.15~30MHz

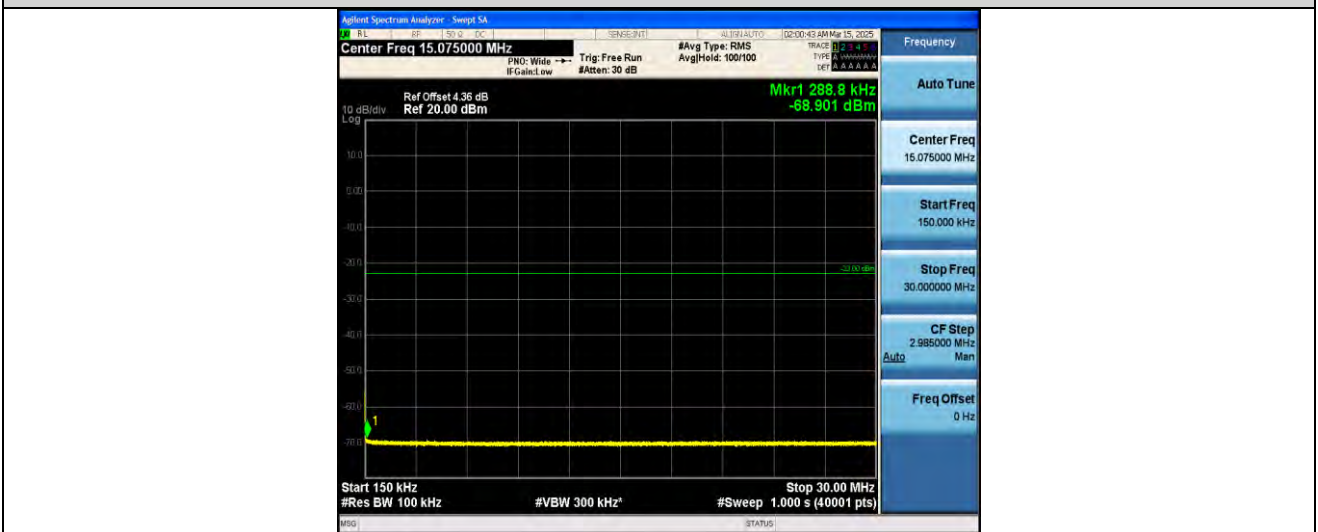

Band2-9400-30~1000MHz



Band2-9400-1000~3000MHz

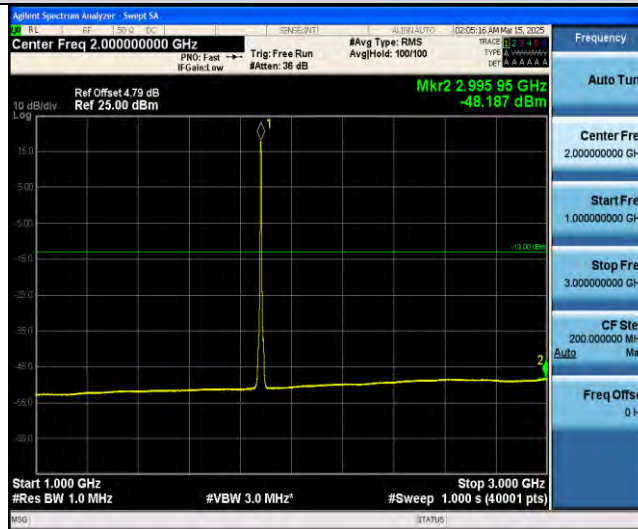

Band2-9400-3000~10000MHz



Band2-9400-10000~20000MHz

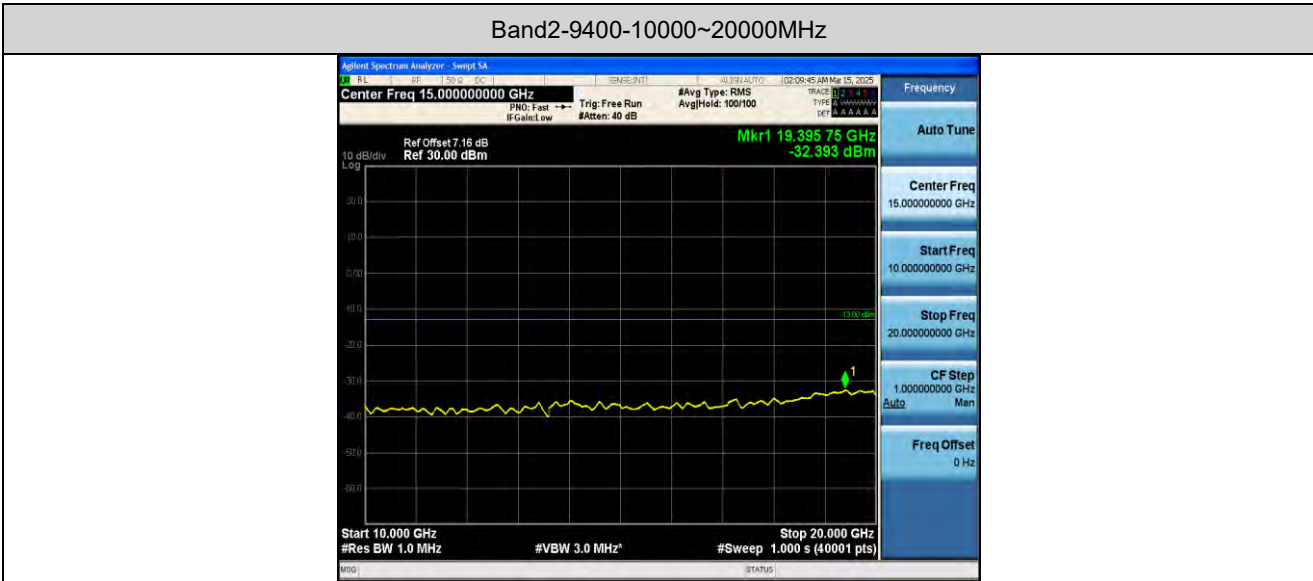

Band2-9538-0.009~0.15MHz

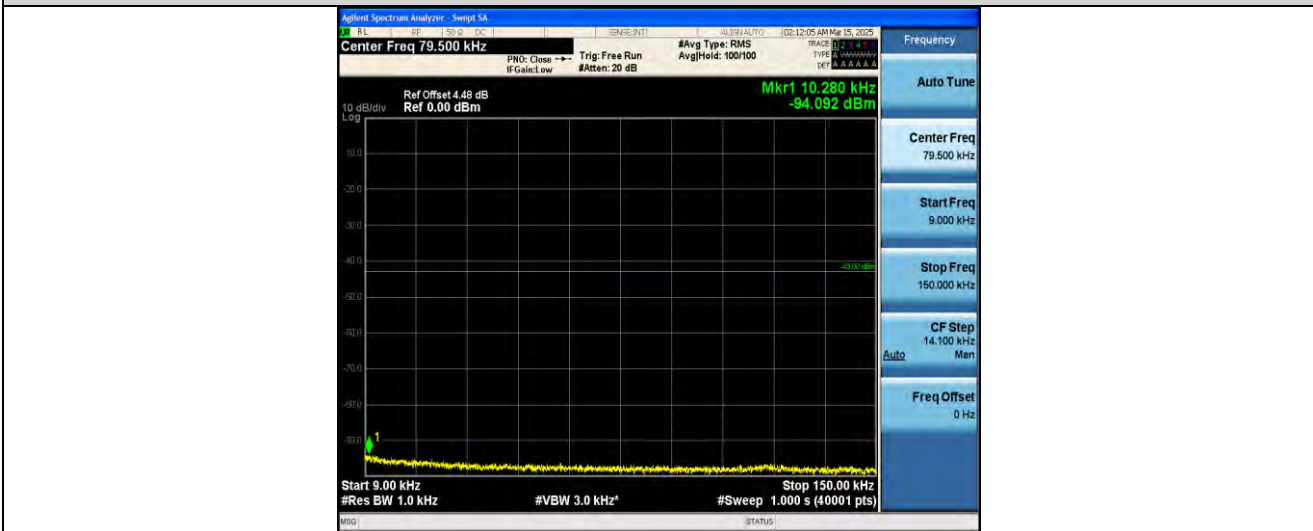

Band2-9538-0.15~30MHz

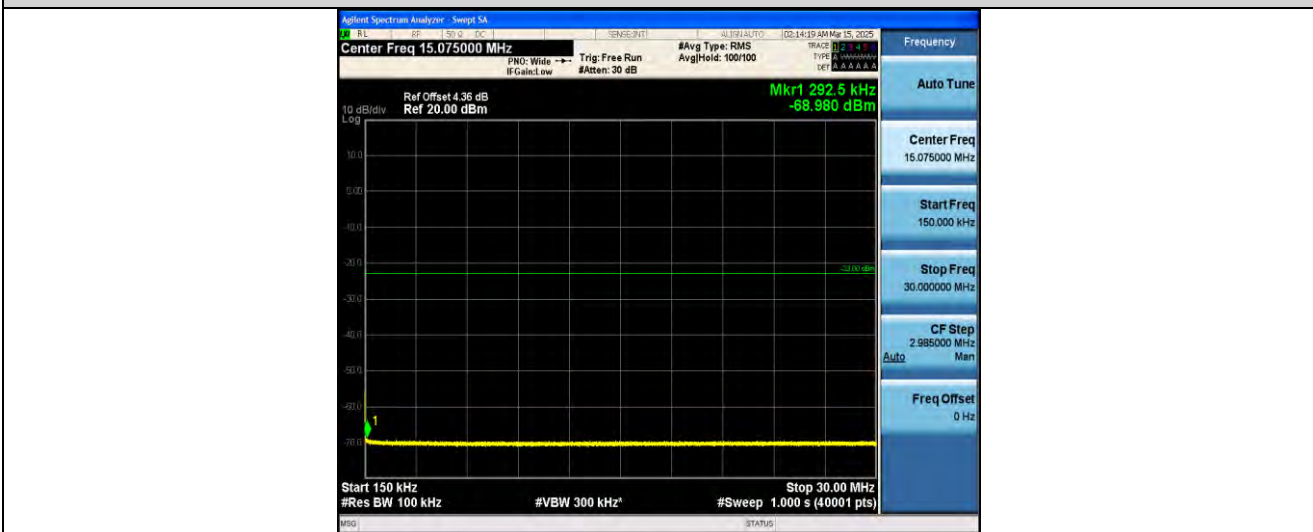

Band2-9538-30~1000MHz

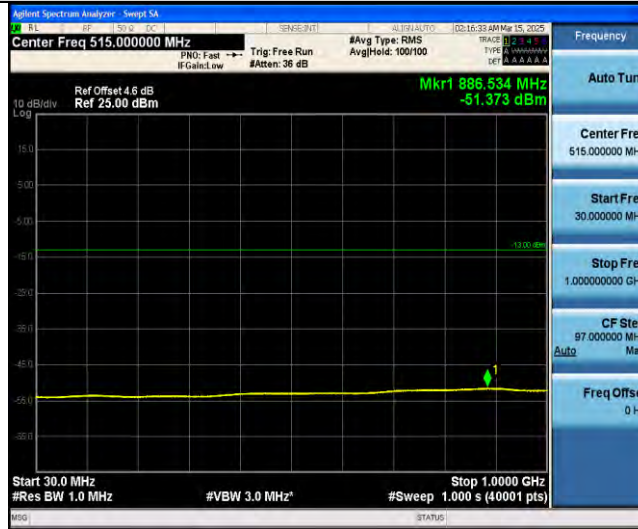

Band2-9538-1000~3000MHz

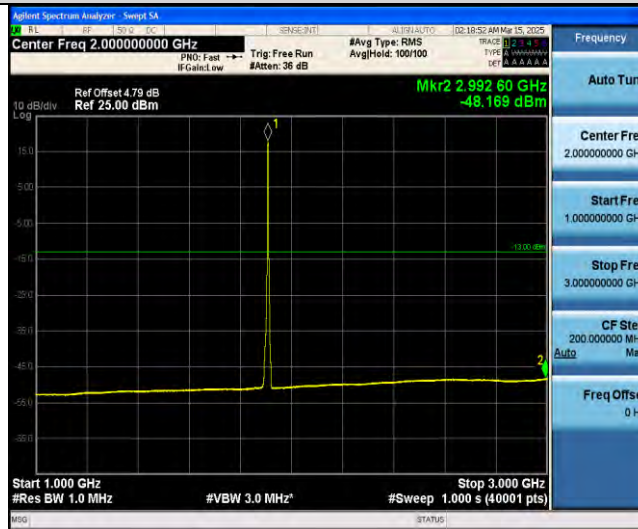

Band2-9538-3000~10000MHz



Band2-9538-10000~20000MHz

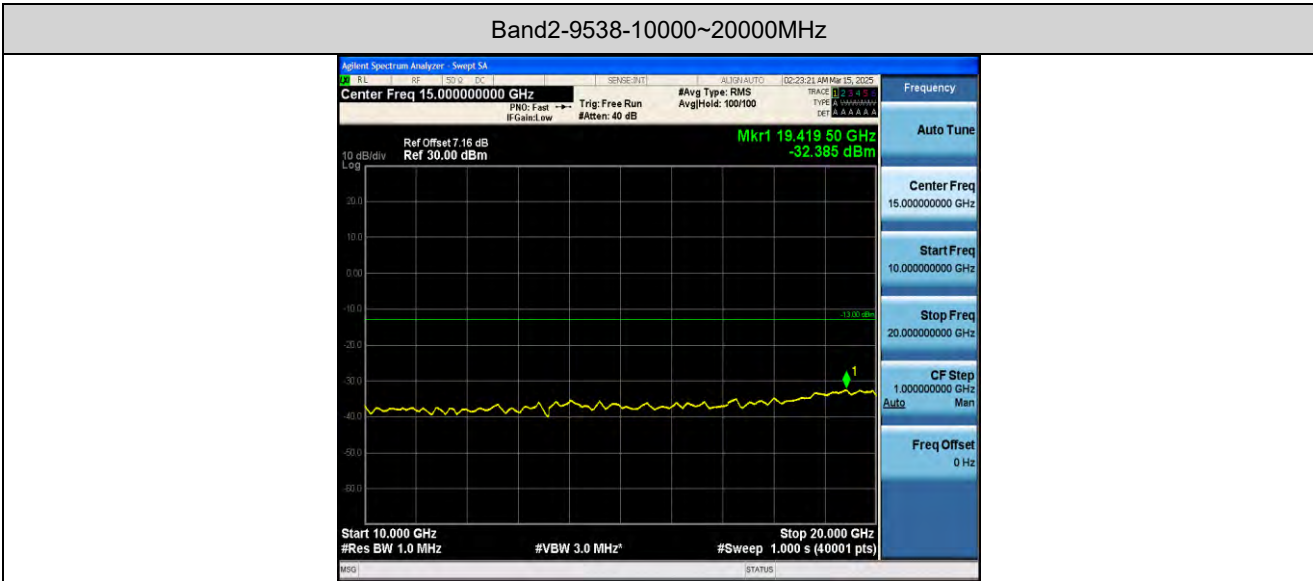

Band5-4132-0.009~0.15MHz



Band5-4132-0.15~30MHz



Band5-4132-30~1000MHz

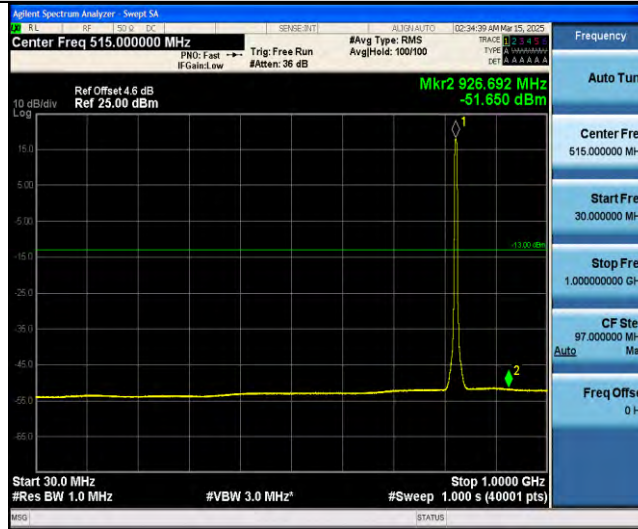

Band5-4132-1000~3000MHz



Band5-4132-3000~10000MHz



Band5-4132-10000~18000MHz

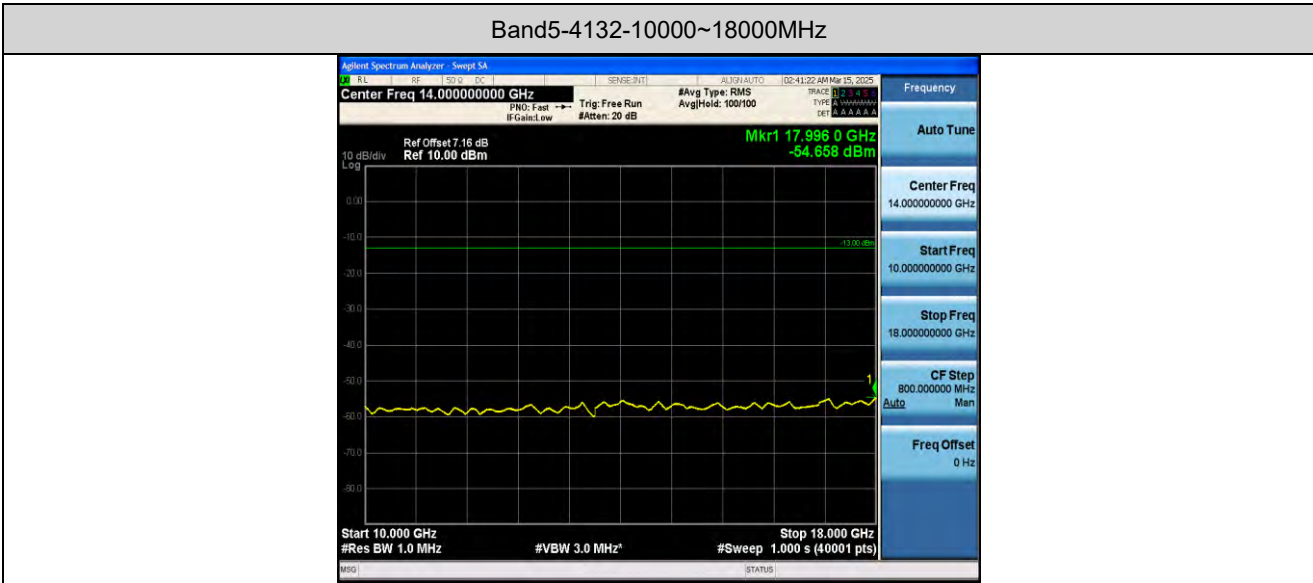

Band5-4182-0.009~0.15MHz

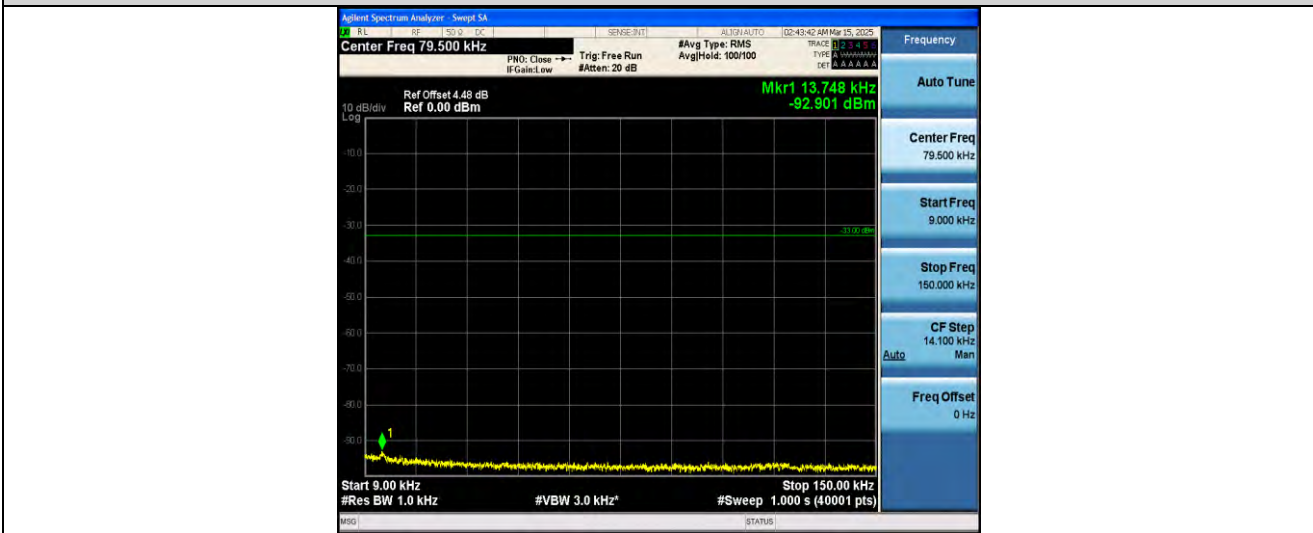

Band5-4182-0.15~30MHz



Band5-4182-30~1000MHz

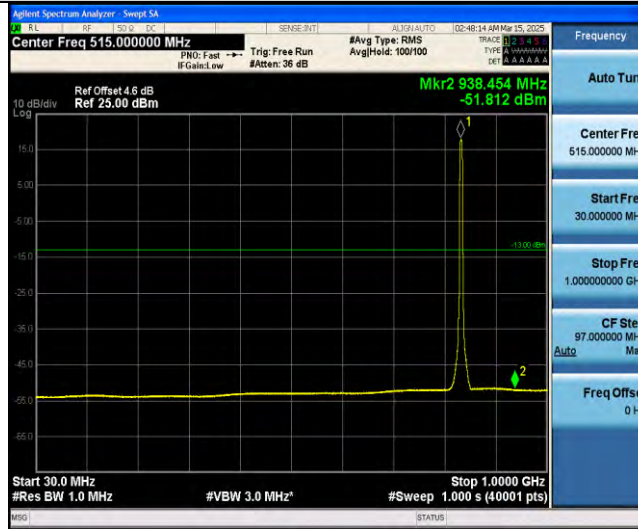

Band5-4182-1000~3000MHz



Band5-4182-3000~10000MHz



Band5-4182-10000~18000MHz

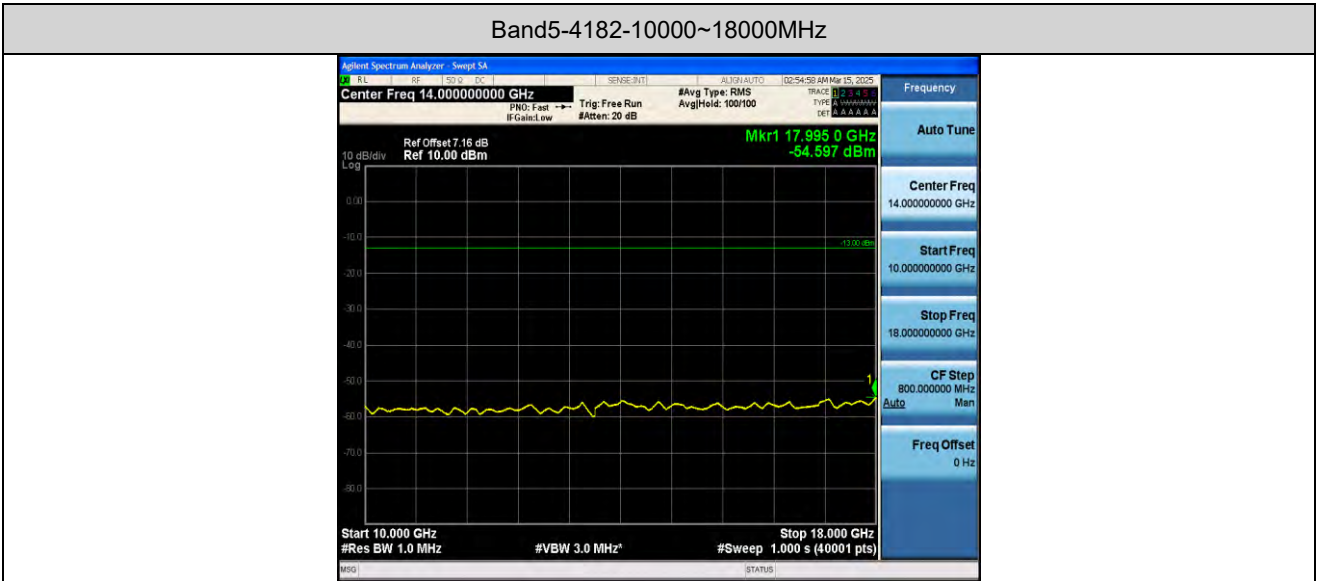

Band5-4233-0.009~0.15MHz

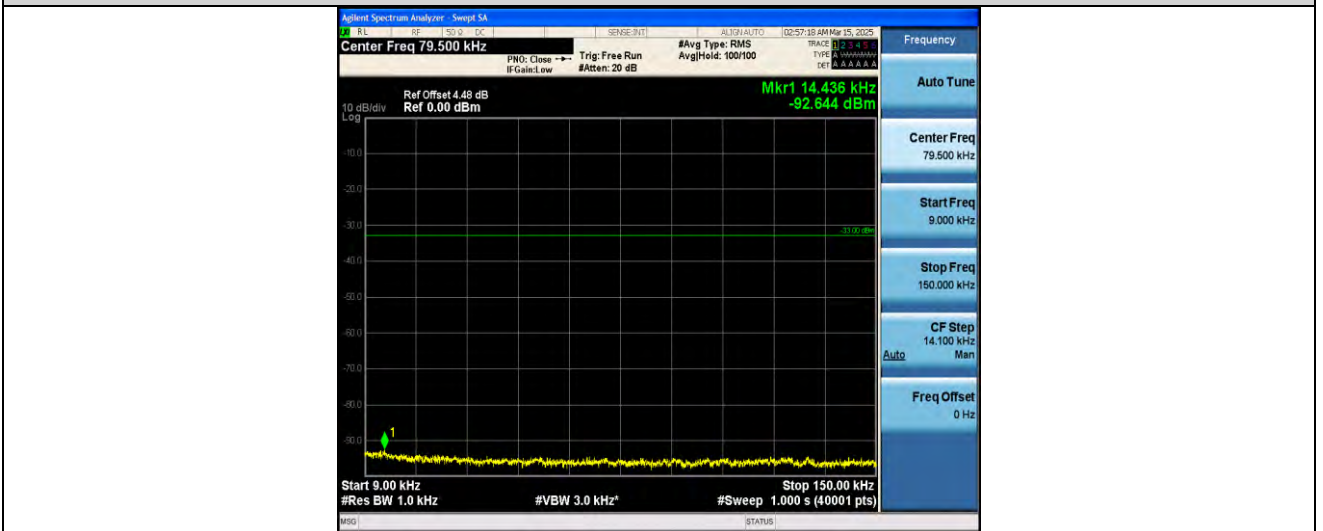

Band5-4233-0.15~30MHz



Band5-4233-30~1000MHz

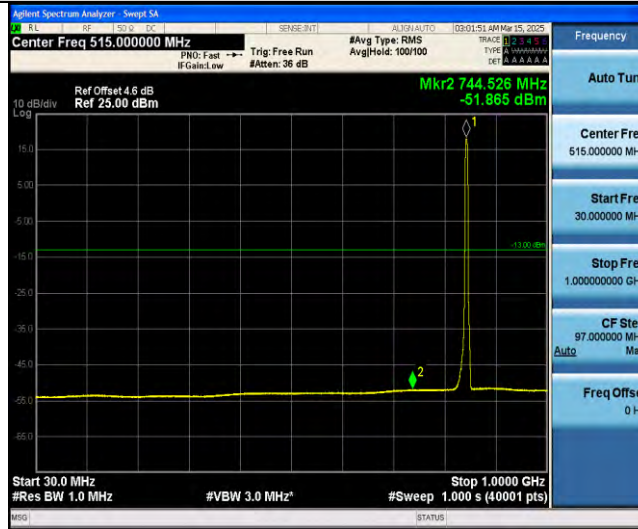

Band5-4233-1000~3000MHz



Band5-4233-3000~10000MHz



Band5-4233-10000~18000MHz

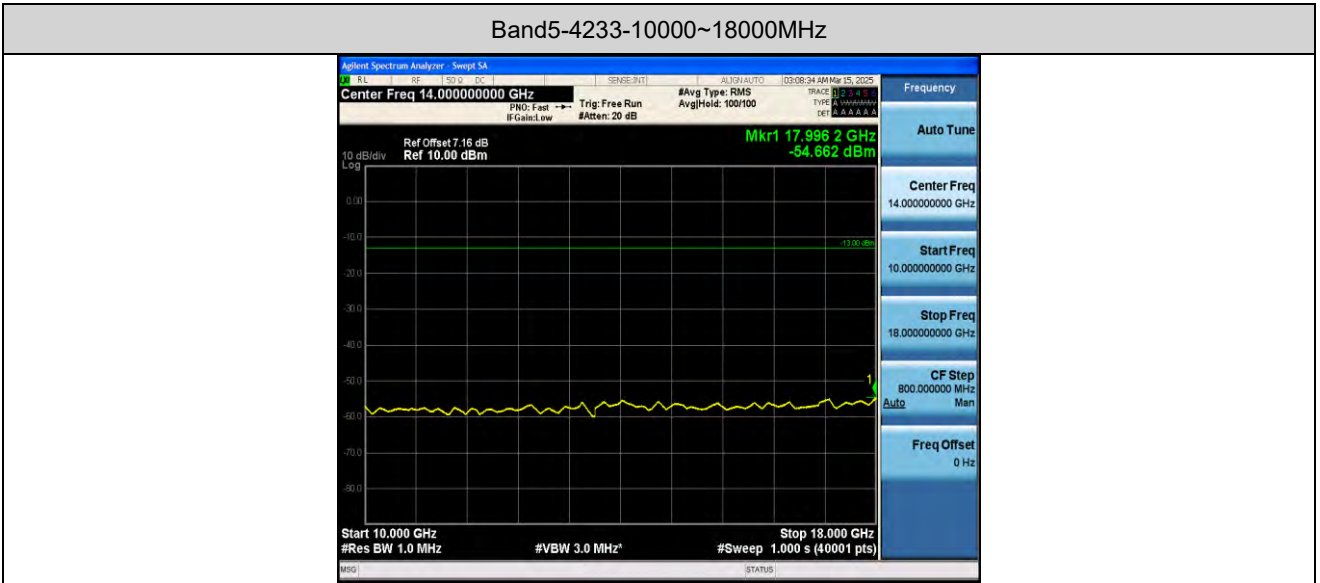

4.7. Field Strength of Spurious Radiation

Test Site:	96603 - WG	Standard:	Part 22H_24E
Test Mode:	WCDMA Band 2 1852.4 MHz		
Polarization:	Horizontal		
Remark:			

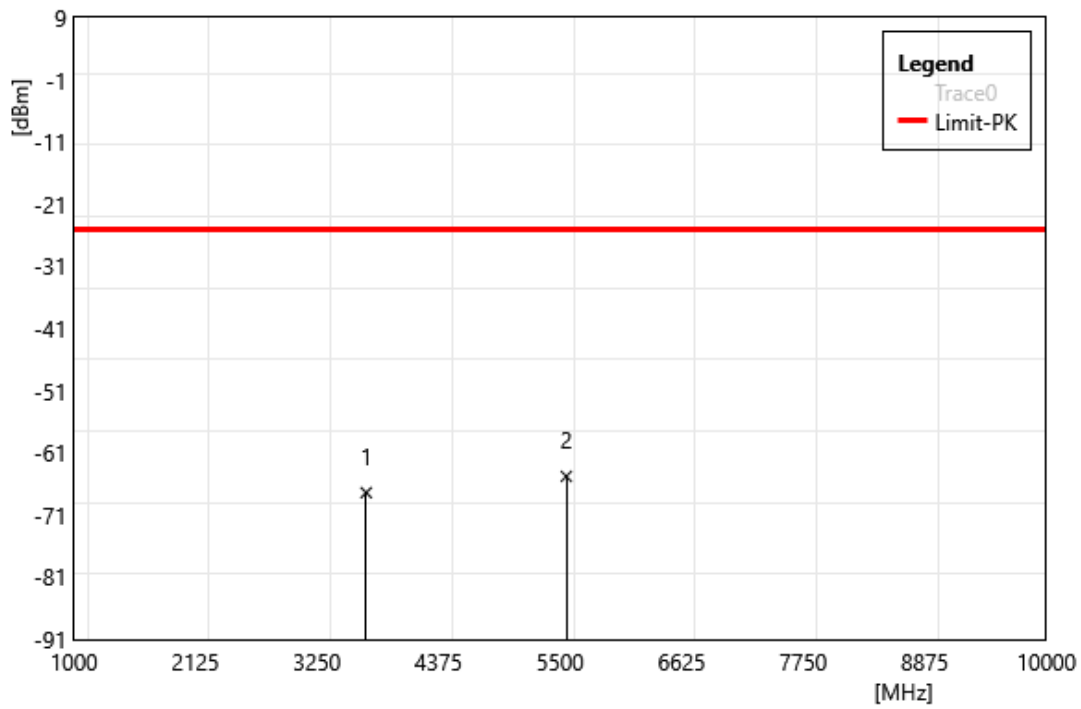

ID	Frequency MHz	Reading dBm	Correct Factor dB/m	Result dBm	Limit dBm	Margin dB	Remark
1	3704.80	-67.78	0.38	-67.40	-25.00	-42.40	PEAK
2	5557.20	-67.83	3.05	-64.78	-25.00	-39.78	PEAK

Test Site:	96603 - WG	Standard:	Part 22H_24E
Test Mode:	WCDMA Band 2 1852.4		
	MHz		
Polarization:	Vertical		
Remark:			

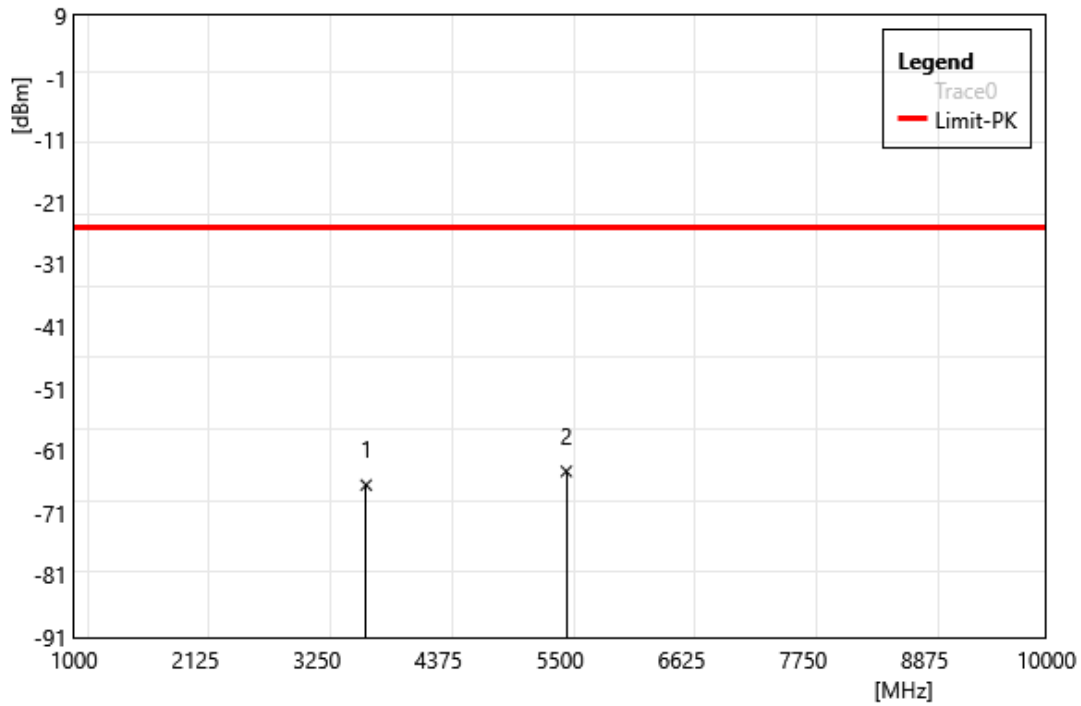

ID	Frequency MHz	Reading dBm	Correct Factor dB/m	Result dBm	Limit dBm	Margin dB	Remark
1	3704.80	-66.87	0.38	-66.49	-25.00	-41.49	PEAK
2	5557.20	-67.34	3.05	-64.29	-25.00	-39.29	PEAK

Test Site:	96603 - WG	Standard:	Part 22H_24E
Test Mode:	WCDMA Band 5 826.4 MHz		
Polarization:	Horizontal		
Remark:			

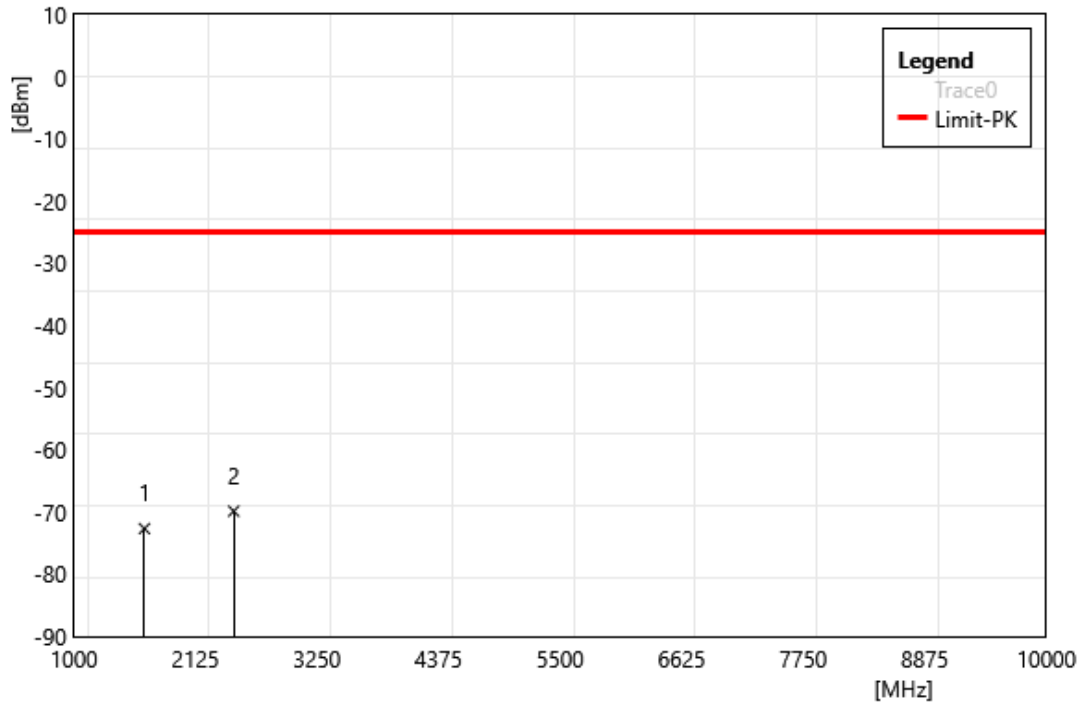

ID	Frequency MHz	Reading dBm	Correct Factor dB/m	Result dBm	Limit dBm	Margin dB	Remark
1	1652.80	-65.63	-7.02	-72.65	-25.00	-47.65	PEAK
2	2479.20	-65.59	-4.27	-69.86	-25.00	-44.86	PEAK

Test Site:	96603 - WG	Standard:	Part 22H_24E
Test Mode:	WCDMA Band 5 826.4 MHz		
Polarization:	Vertical		
Remark:			

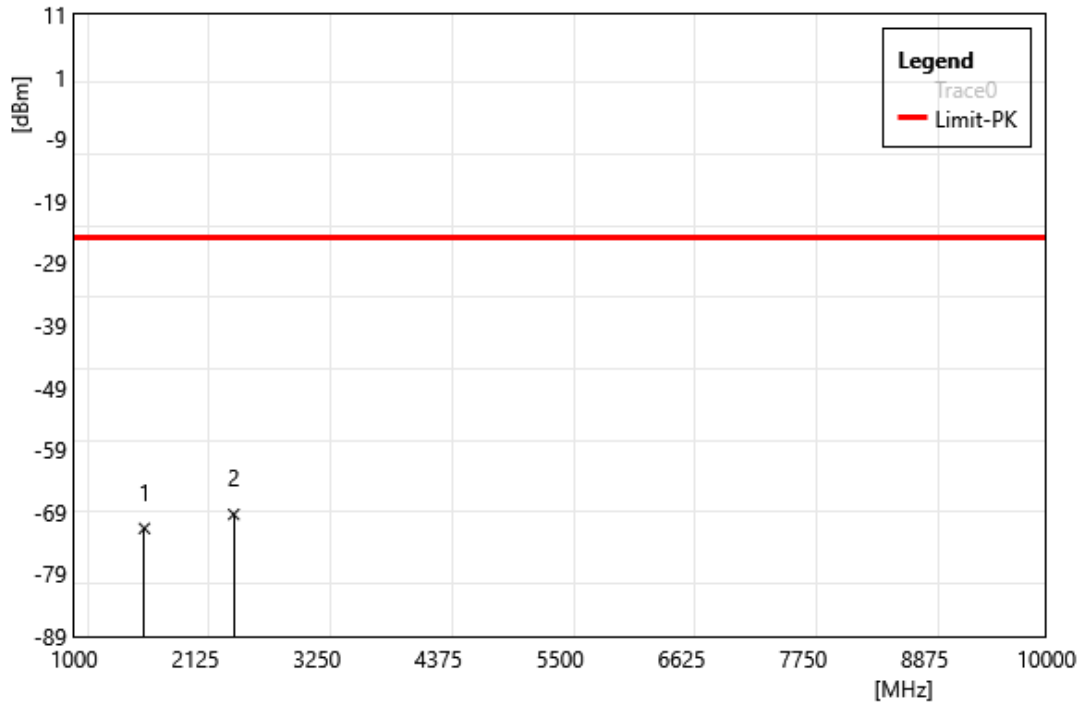

ID	Frequency MHz	Reading dBm	Correct Factor dB/m	Result dBm	Limit dBm	Margin dB	Remark
1	1652.80	-64.61	-7.02	-71.63	-25.00	-46.63	PEAK
2	2479.20	-65.11	-4.27	-69.38	-25.00	-44.38	PEAK

Test Site:	96603 - WG	Standard:	Part 22_24_27
Test Mode:	Co-location		
Polarization:	Horizontal		
Remark:	2.4G+WCDMA		

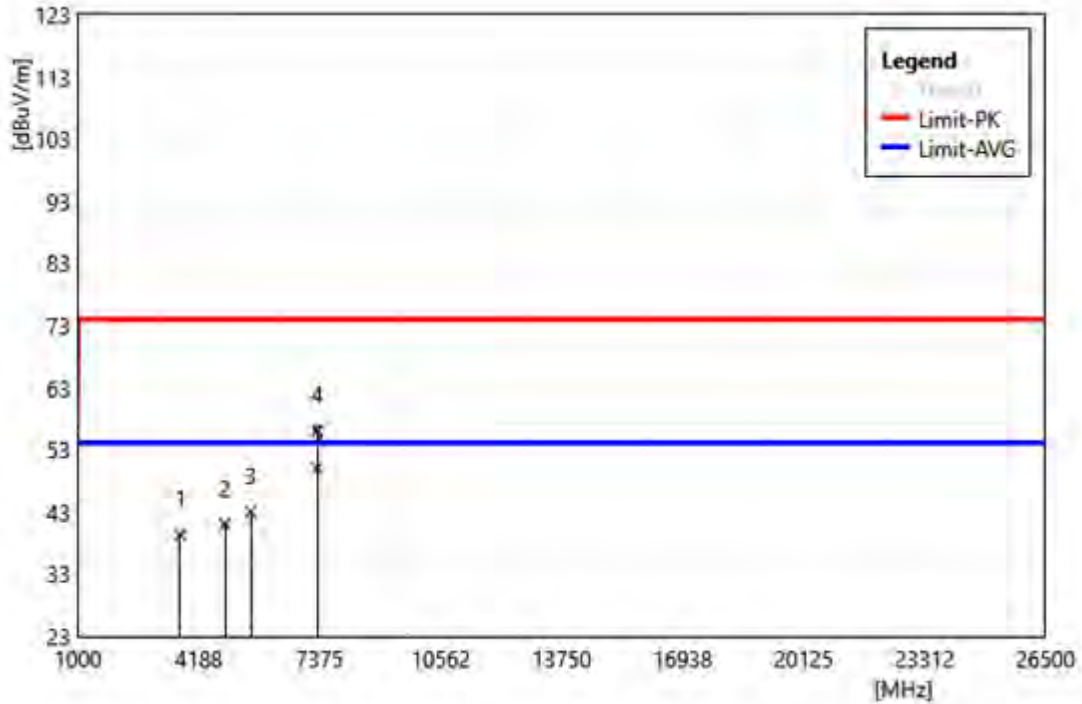

ID	Frequency MHz	Reading dBuV	Correct Factor dB/m	Result dBuV/m	Limit dBuV/m	Margin dB	Remark
1	3704.80	39.01	0.38	39.39	74.00	-34.61	PEAK
2	4874.00	38.40	2.60	41.00	74.00	-33.00	PEAK
3	5557.20	39.97	3.05	43.02	74.00	-30.98	PEAK
4	7311.00	48.01	8.06	56.07	74.00	-17.93	PEAK
5	7311.00	41.96	8.06	50.02	54.00	-3.98	AVG

Test Site:	96603 - WG	Standard:	Part 22_24_27
Test Mode:	Co-location		
Polarization:	Vertical		
Remark:	2.4G+WCDMA		

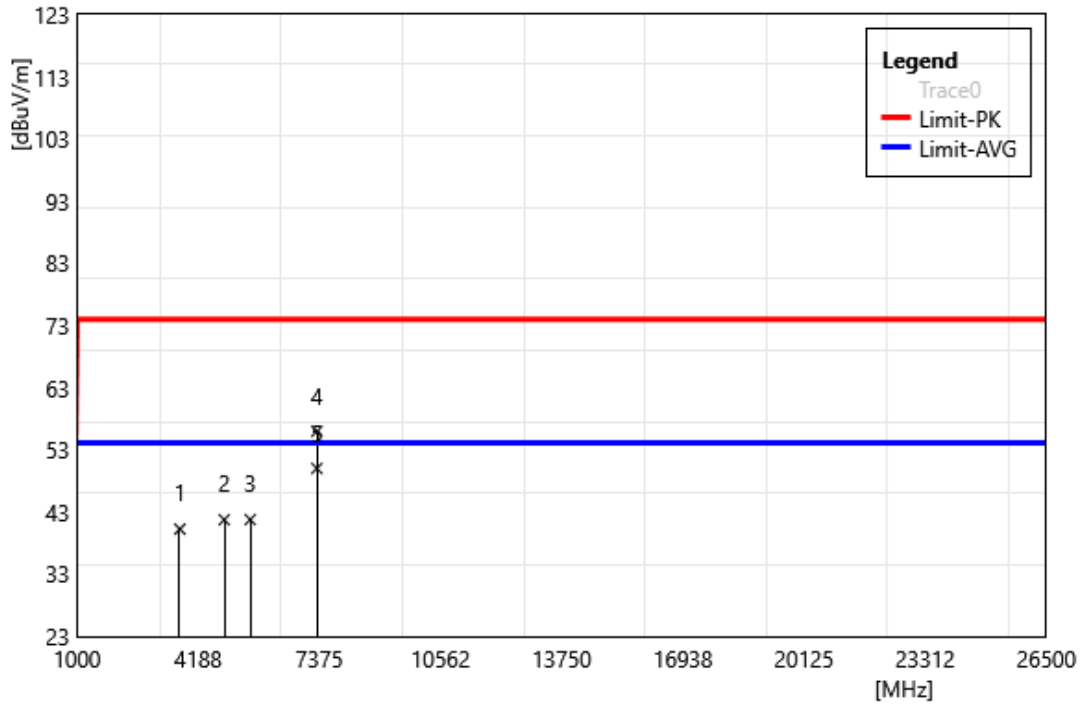

ID	Frequency MHz	Reading dBuV	Correct Factor dB/m	Result dBuV/m	Limit dBuV/m	Margin dB	Remark
1	3704.80	39.88	0.38	40.26	74.00	-33.74	PEAK
2	4874.00	39.16	2.60	41.76	74.00	-32.24	PEAK
3	5557.20	38.75	3.05	41.80	74.00	-32.20	PEAK
4	7311.00	47.93	8.06	55.99	74.00	-18.01	PEAK
5	7311.00	41.95	8.06	50.01	54.00	-3.99	AVG

Test Site:	96603 - WG	Standard:	Part 22_24_27
Test Mode:	Co-location		
Polarization:	Horizontal		
Remark:	5G+WCDMA		

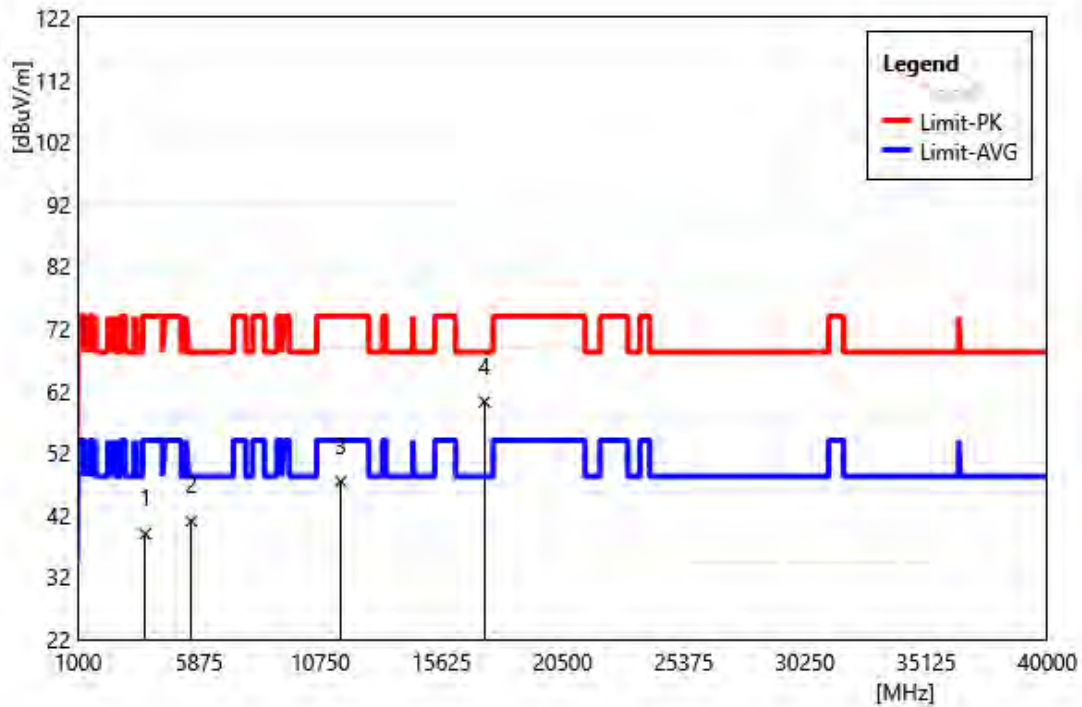

ID	Frequency MHz	Reading dBuV	Correct Factor dB/m	Result dBuV/m	Limit dBuV/m	Margin dB	Remark
1	3704.80	38.59	0.38	38.97	74.00	-35.03	PEAK
2	5557.20	37.98	3.05	41.03	68.20	-27.17	PEAK
3	11570.00	38.59	8.80	47.39	74.00	-26.61	PEAK
4	17355.00	52.58	7.64	60.22	68.20	-7.98	PEAK

Test Site:	96603 - WG	Standard:	Part 22_24_27
Test Mode:	Co-location		
Polarization:	Vertical		
Remark:	5G+WCDMA		

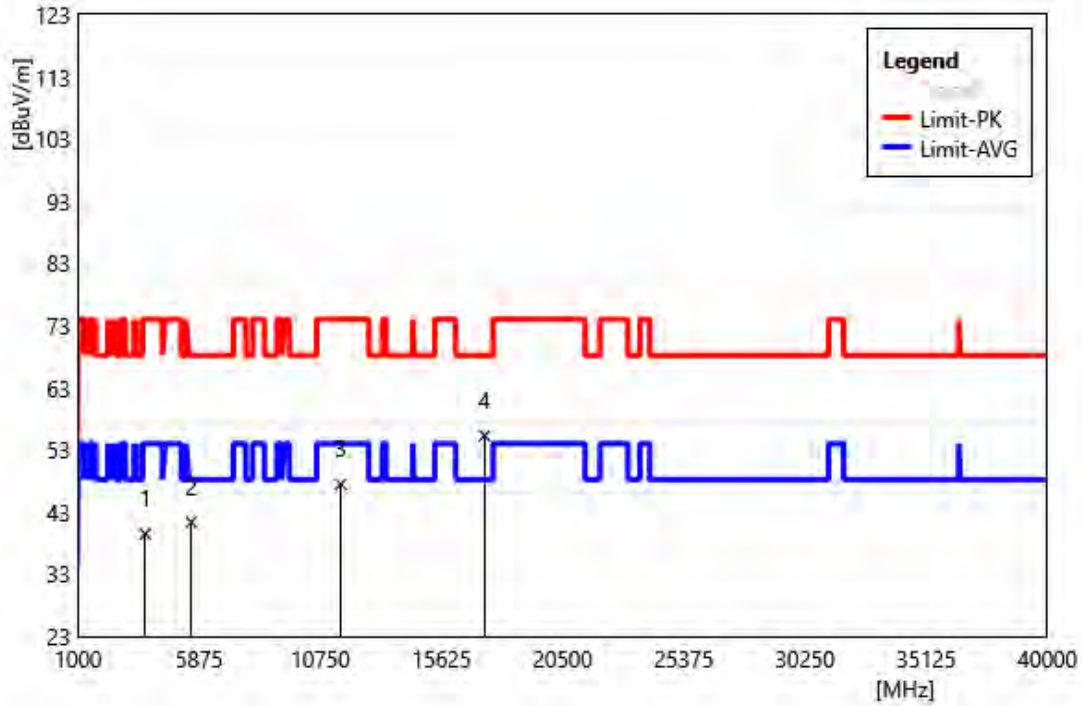

ID	Frequency MHz	Reading dBuV	Correct Factor dB/m	Result dBuV/m	Limit dBuV/m	Margin dB	Remark
1	3704.80	39.10	0.38	39.48	74.00	-34.52	PEAK
2	5557.20	38.33	3.05	41.38	68.20	-26.82	PEAK
3	11570.00	38.69	8.80	47.49	74.00	-26.51	PEAK
4	17355.00	47.63	7.64	55.27	68.20	-12.93	PEAK

4.8. Frequency Stability for Temperature & Voltage

Frequency Error vs. Voltage:

Voltage							
Band	Channel	Voltage (Vdc)	Temperature (°C)	Deviation (Hz)	Deviation (ppm)	Limit (ppm)	Verdict
Band2	9262	VL	NT	18.63	0.010057	±2.5	PASS
Band2	9262	VN	NT	18.78	0.010138	±2.5	PASS
Band2	9262	VH	NT	14.33	0.007736	±2.5	PASS
Band2	9400	VL	NT	14.33	0.007622	±2.5	PASS
Band2	9400	VN	NT	13.00	0.006915	±2.5	PASS
Band2	9400	VH	NT	17.76	0.009447	±2.5	PASS
Band2	9538	VL	NT	13.23	0.006935	±2.5	PASS
Band2	9538	VN	NT	18.36	0.009625	±2.5	PASS
Band2	9538	VH	NT	19.33	0.010133	±2.5	PASS
Band5	4132	VL	NT	5.74	0.006946	±2.5	PASS
Band5	4132	VN	NT	9.48	0.011471	±2.5	PASS
Band5	4132	VH	NT	6.91	0.008362	±2.5	PASS
Band5	4182	VL	NT	5.84	0.006982	±2.5	PASS
Band5	4182	VN	NT	10.57	0.012637	±2.5	PASS
Band5	4182	VH	NT	8.56	0.010234	±2.5	PASS
Band5	4233	VL	NT	5.63	0.006650	±2.5	PASS
Band5	4233	VN	NT	10.62	0.012544	±2.5	PASS
Band5	4233	VH	NT	12.41	0.014659	±2.5	PASS

Frequency Error vs. Temperature:

Temperature							
Band	Channel	Voltage (Vdc)	Temperature (°C)	Deviation (Hz)	Deviation (ppm)	Limit (ppm)	Verdict
Band2	9262	NV	-30	15.93	0.008600	±2.5	PASS
Band2	9262	NV	-20	18.33	0.009895	±2.5	PASS
Band2	9262	NV	-10	19.13	0.010327	±2.5	PASS
Band2	9262	NV	0	15.53	0.008384	±2.5	PASS
Band2	9262	NV	10	15.91	0.008589	±2.5	PASS
Band2	9262	NV	20	18.33	0.009895	±2.5	PASS
Band2	9262	NV	30	17.12	0.009242	±2.5	PASS
Band2	9262	NV	40	17.82	0.009620	±2.5	PASS
Band2	9262	NV	50	17.44	0.009415	±2.5	PASS
Band2	9400	NV	-30	17.88	0.009511	±2.5	PASS
Band2	9400	NV	-20	19.73	0.010495	±2.5	PASS
Band2	9400	NV	-10	22.81	0.012133	±2.5	PASS
Band2	9400	NV	0	18.75	0.009973	±2.5	PASS
Band2	9400	NV	10	19.36	0.010298	±2.5	PASS
Band2	9400	NV	20	16.39	0.008718	±2.5	PASS
Band2	9400	NV	30	15.55	0.008271	±2.5	PASS
Band2	9400	NV	40	18.26	0.009713	±2.5	PASS
Band2	9400	NV	50	15.30	0.008138	±2.5	PASS
Band2	9538	NV	-30	18.77	0.009840	±2.5	PASS
Band2	9538	NV	-20	15.03	0.007879	±2.5	PASS
Band2	9538	NV	-10	16.85	0.008833	±2.5	PASS
Band2	9538	NV	0	20.65	0.010825	±2.5	PASS
Band2	9538	NV	10	17.40	0.009121	±2.5	PASS
Band2	9538	NV	20	17.04	0.008933	±2.5	PASS
Band2	9538	NV	30	18.72	0.009813	±2.5	PASS
Band2	9538	NV	40	13.57	0.007114	±2.5	PASS
Band2	9538	NV	50	15.11	0.007921	±2.5	PASS

Temperature							
Band	Channel	Voltage (Vdc)	Temperature (°C)	Deviation (Hz)	Deviation (ppm)	Limit (ppm)	Verdict
Band5	4132	NV	-30	13.76	0.016651	±2.5	PASS
Band5	4132	NV	-20	9.66	0.011689	±2.5	PASS
Band5	4132	NV	-10	11.22	0.013577	±2.5	PASS
Band5	4132	NV	0	8.29	0.010031	±2.5	PASS
Band5	4132	NV	10	8.74	0.010576	±2.5	PASS
Band5	4132	NV	20	8.39	0.010152	±2.5	PASS
Band5	4132	NV	30	5.42	0.006559	±2.5	PASS
Band5	4132	NV	40	8.33	0.010080	±2.5	PASS
Band5	4132	NV	50	11.23	0.013589	±2.5	PASS
Band5	4182	NV	-30	10.59	0.012661	±2.5	PASS
Band5	4182	NV	-20	11.00	0.013152	±2.5	PASS
Band5	4182	NV	-10	12.54	0.014993	±2.5	PASS
Band5	4182	NV	0	11.44	0.013678	±2.5	PASS
Band5	4182	NV	10	9.95	0.011896	±2.5	PASS
Band5	4182	NV	20	9.78	0.011693	±2.5	PASS
Band5	4182	NV	30	15.63	0.018687	±2.5	PASS
Band5	4182	NV	40	9.61	0.011490	±2.5	PASS
Band5	4182	NV	50	12.22	0.014610	±2.5	PASS
Band5	4233	NV	-30	7.92	0.009355	±2.5	PASS
Band5	4233	NV	-20	10.94	0.012922	±2.5	PASS
Band5	4233	NV	-10	13.41	0.015840	±2.5	PASS
Band5	4233	NV	0	9.03	0.010666	±2.5	PASS
Band5	4233	NV	10	6.32	0.007465	±2.5	PASS
Band5	4233	NV	20	10.19	0.012036	±2.5	PASS
Band5	4233	NV	30	12.73	0.015037	±2.5	PASS
Band5	4233	NV	40	11.02	0.013017	±2.5	PASS
Band5	4233	NV	50	11.72	0.013844	±2.5	PASS

--- END---