

FCC Test Report

Report No.: RF160311D14-1

FCC ID: KA2DAP1860A1

Test Model: DAP-1860

Received Date: Mar. 14, 2016

Test Date: Mar. 21 ~ Apr. 19, 2016

Issued Date: May 13, 2016

Applicant: D-Link Corporation

Address: 17595 Mt. Hermann, Fountain Valley, CA 92708, U.S.A.

Issued By: Bureau Veritas Consumer Products Services (H.K.) Ltd., Taoyuan Branch

Lab Address: No. 47-2, 14th Ling, Chia Pau Vil., Lin Kou Dist., New Taipei City, Taiwan (R.O.C.)



This report is for your exclusive use. Any copying or replication of this report to or for any other person or entity, or use of our name or trademark, is permitted only with our prior written permission. This report sets forth our findings solely with respect to the test samples identified herein. The results set forth in this report are not indicative or representative of the quality or characteristics of the lot from which a test sample was taken or any similar or identical product unless specifically and expressly noted. Our report includes all of the tests requested by you and the results thereof based upon the information that you provided to us. You have 60 days from date of issuance of this report to notify us of any material error or omission caused by our negligence, provided, however, that such notice shall be in writing and shall specifically address the issue you wish to raise. A failure to raise such issue within the prescribed time shall constitute your unqualified acceptance of the completeness of this report, the tests conducted and the correctness of the report contents. Unless specific mention, the uncertainty of measurement has been explicitly taken into account to declare the compliance or non-compliance to the specification. The report must not be used by the client to claim product certification, approval, or endorsement by TAF or any government agencies.

Table of Contents

Release Control Record	4
1 Certificate of Conformity	5
2 Summary of Test Results	6
2.1 Measurement Uncertainty	6
2.2 Modification Record	6
3 General Information	7
3.1 General Description of EUT	7
3.2 Description of Test Modes	9
3.2.1 Test Mode Applicability and Tested Channel Detail.....	10
3.3 Duty Cycle of Test Signal	13
3.4 Description of Support Units	14
3.4.1 Configuration of System under Test	14
3.5 General Description of Applied Standard.....	15
4 Test Types and Results	16
4.1 Radiated Emission and Bandedge Measurement.....	16
4.1.1 Limits of Radiated Emission and Bandedge Measurement	16
4.1.2 Test Instruments	17
4.1.3 Test Procedure	18
4.1.4 Deviation from Test Standard	18
4.1.5 Test Setup.....	19
4.1.6 EUT Operating Condition	19
4.1.7 Test Results	20
4.2 Conducted Emission Measurement	51
4.2.1 Limits of Conducted Emission Measurement.....	51
4.2.2 Test Instruments	51
4.2.3 Test Procedure	52
4.2.4 Deviation from Test Standard	52
4.2.5 Test Setup.....	52
4.2.6 EUT Operating Condition	52
4.2.7 Test Results	53
4.3 Transmit Power Measurement	55
4.3.1 Limits of Transmit Power Measurement	55
4.3.2 Test Setup.....	55
4.3.3 Test Instruments	55
4.3.4 Test Procedure	56
4.3.5 Deviation from Test Standard	56
4.3.6 EUT Operating Condition	56
4.3.7 Test Result.....	57
4.4 Peak Power Spectral Density Measurement	64
4.4.1 Limits of Peak Power Spectral Density Measurement	64
4.4.2 Test Setup.....	64
4.4.3 Test Instruments	64
4.4.4 Test Procedure	64
4.4.5 Deviation from Test Standard	64
4.4.6 EUT Operating Condition	64
4.4.7 Test Results	65
4.5 Frequency Stability Measurement	71
4.5.1 Limits of Frequency Stability Measurement	71
4.5.2 Test Setup.....	71
4.5.3 Test Instruments	71
4.5.4 Test Procedure	71
4.5.5 Deviation from Test Standard	71
4.5.6 EUT Operating Condition	71

4.5.7 Test Results	72
4.6 6dB Bandwidth Measurement	73
4.6.1 Limits of 6dB Bandwidth Measurement	73
4.6.2 Test Setup	73
4.6.3 Test Instruments	73
4.6.4 Test Procedure	73
4.6.5 Deviation from Test Standard	73
4.6.6 EUT Operating Condition	73
4.6.7 Test Results	74
5 Pictures of Test Arrangements	76
Annex A- Radiated Out of Band Emisison (OOBE) Measurement (For U-NII-3 band)	77
Appendix – Information on the Testing Laboratories	82

Release Control Record

Issue No.	Description	Date Issued
RF160311D14-1	Original release.	May 13, 2016

1 Certificate of Conformity

Product: AC2600 Wi-Fi Range Extender

Brand: D-Link

Test Model: DAP-1860

Sample Status: Engineering sample

Applicant: D-Link Corporation

Test Date: Mar. 21 ~ Apr. 19, 2016

Standard: 47 CFR FCC Part 15, Subpart E (Section 15.407)
ANSI C63.10: 2013

The above equipment has been tested by **Bureau Veritas Consumer Products Services (H.K.) Ltd., Taoyuan Branch**, and found compliance with the requirement of the above standards. The test record, data evaluation & Equipment Under Test (EUT) configurations represented herein are true and accurate accounts of the measurements of the sample's EMC characteristics under the conditions specified in this report.

Prepared by :

Annie Chang

Annie Chang / Senior Specialist

Date:

May 13, 2016

Approved by :

Rex Lai

Rex Lai / Assistant Manager

Date:

May 13, 2016

2 Summary of Test Results

47 CFR FCC Part 15, Subpart E (SECTION 15.407)			
FCC Clause	Test Item	Result	Remarks
15.407(b)(6)	AC Power Conducted Emissions	Pass	Meet the requirement of limit. Minimum passing margin is -13.20dB at 10.86328MHz.
15.407(b) (1/2/3/4(i/ii)/6)	Radiated Emissions & Band Edge Measurement*	Pass	Meet the requirement of limit. Minimum passing margin is -1.1dB at 5150.00MHz.
15.407(a)(1/2/3)	Max Average Transmit Power	Pass	Meet the requirement of limit.
15.407(a)(1/2/3)	Peak Power Spectral Density	Pass	Meet the requirement of limit.
15.407(e)	6dB bandwidth	Pass	Meet the requirement of limit. (U-NII-3 Band only)
15.407(g)	Frequency Stability	Pass	Meet the requirement of limit.
15.203	Antenna Requirement	Pass	Antenna connector is I-PEX not a standard connector.

*For U-NII-3 band compliance with rule part 15.407(b)(i), the OOB test plots were recorded in Annex A.

2.1 Measurement Uncertainty

Where relevant, the following measurement uncertainty levels have been estimated for tests performed on the EUT as specified in CISPR 16-4-2:

Measurement	Frequency	Expanded Uncertainty (k=2) (\pm)
Conducted Emissions at mains ports	150kHz ~ 30MHz	2.78 dB
Radiated Emissions up to 1 GHz	30MHz ~ 1000MHz	4.00 dB
Radiated Emissions above 1 GHz	1GHz ~ 40GHz	3.36 dB

2.2 Modification Record

There were no modifications required for compliance.

3 General Information

3.1 General Description of EUT

Product	AC2600 Wi-Fi Range Extender
Brand	D-Link
Test Model	DAP-1860
Status of EUT	Engineering sample
Power Supply Rating	100-240Vac, 50-60Hz, 0.5A
Modulation Type	64QAM, 16QAM, QPSK, BPSK 256QAM for OFDM in 11ac mode only.
Modulation Technology	OFDM
Transfer Rate	802.11a: 54/48/36/24/18/12/9/6Mbps 802.11n: up to 600Mbps 802.11ac: up to 1732Mbps
Operating Frequency	5180 ~ 5240MHz 5745 ~ 5825MHz
Number of Channel	5180 ~ 5240MHz 4 for 802.11a, 802.11n (HT20) 2 for 802.11n (HT40) 1 for 802.11ac (VHT80) 5745 ~ 5825MHz 5 for 802.11a, 802.11n (HT20) 2 for 802.11n (HT40) 1 for 802.11ac (VHT80)
Output Power	5180 ~ 5240MHz: 457.745mW 5745 ~ 5825MHz: 438.058mW
Antenna Type	CDD Mode: PCB antenna with 3dBi gain Beamforming Mode: PCB antenna with 7.55dBi gain
Antenna Connector	I-PEX
Accessory Device	N/A
Data Cable Supplied	N/A

Note:

1. The EUT provides 4 completed transmitters and 4 receivers.

Modulation Mode	TX Function	
	5.0GHz (Non-Beamforming)	5.0GHz (Beamforming)
802.11a	4TX	-
802.11n (20MHz)	4TX	-
802.11n (40MHz)	4TX	-
802.11ac (20MHz)	4TX	4TX
802.11ac (40MHz)	4TX	4TX
802.11ac (80MHz)	4TX	4TX

* The modulation and bandwidth are similar for 802.11n mode for 20MHz / 40MHz and 802.11ac mode for 20MHz / 40MHz, therefore investigated worst case to representative mode in test report. (Final test mode refer section 3.2.1)

2. The above EUT information is declared by manufacturer and for more detailed features description, please refer to the manufacturer's specifications or user's manual.

3.2 Description of Test Modes

FOR 5180 ~ 5240MHz:

4 channels are provided for 802.11a, 802.11n (20MHz), 802.11ac (20MHz):

Channel	Frequency	Channel	Frequency
36	5180 MHz	44	5220 MHz
40	5200 MHz	48	5240 MHz

2 channels are provided for 802.11n (40MHz), 802.11ac (40MHz):

Channel	Frequency	Channel	Frequency
38	5190 MHz	46	5230 MHz

1 channel is provided for 802.11ac (80MHz):

Channel	Frequency
42	5210MHz

FOR 5745 ~ 5825MHz:

5 channels are provided for 802.11a, 802.11n (20MHz), 802.11ac (20MHz):

Channel	Frequency	Channel	Frequency
149	5745MHz	161	5805MHz
153	5765MHz	165	5825MHz
157	5785MHz		

2 channels are provided for 802.11n (40MHz), 802.11ac (40MHz):

Channel	Frequency	Channel	Frequency
151	5755MHz	159	5795MHz

1 channel is provided for 802.11ac (80MHz):

Channel	Frequency
155	5775MHz

3.2.1 Test Mode Applicability and Tested Channel Detail

EUT Configure Mode	Applicable To				Description
	RE \geq 1G	RE $<$ 1G	PLC	APCM	
-	√	√	√	√	-

Where **RE \geq 1G**: Radiated Emission above 1GHz

RE $<$ 1G: Radiated Emission below 1GHz

PLC: Power Line Conducted Emission

APCM: Antenna Port Conducted Measurement

NOTE: The EUT had been pre-tested on the positioned of each 3 axis. The worst case was found when positioned on **X-plane**.

Radiated Emission Test (Above 1GHz):

- Pre-Scan has been conducted to determine the worst-case mode from all possible combinations between available modulations, data rates and antenna ports (if EUT with antenna diversity architecture).
- Following channel(s) was (were) selected for the final test as listed below.

CDD Mode							
EUT CONFIGURE MODE	MODE	FREQ. BAND (MHz)	AVAILABLE CHANNEL	TESTED CHANNEL	MODULATION TECHNOLOGY	MODULATION TYPE	DATA RATE (Mbps)
-	802.11a	5180-5240	36 to 48	36, 40, 48	OFDM	BPSK	6.0
-	802.11ac (20MHz)		36 to 48	36, 40, 48	OFDM	BPSK	6.5
-	802.11ac (40MHz)		38 to 46	38, 46	OFDM	BPSK	13.0
-	802.11ac (80MHz)		42	42	OFDM	BPSK	29.3
-	802.11a	5745-5825	149 to 165	149, 157, 165	OFDM	BPSK	6.0
-	802.11ac (20MHz)		149 to 165	149, 157, 165	OFDM	BPSK	6.5
-	802.11ac (40MHz)		151 to 159	151, 159	OFDM	BPSK	13.0
-	802.11ac (80MHz)		155	155	OFDM	BPSK	29.3
Beamforming Mode							
EUT CONFIGURE MODE	MODE	FREQ. BAND (MHz)	AVAILABLE CHANNEL	TESTED CHANNEL	MODULATION TECHNOLOGY	MODULATION TYPE	DATA RATE (Mbps)
-	802.11ac (20MHz)	5180-5240	36 to 48	36, 40, 48	OFDM	BPSK	6.5
-	802.11ac (40MHz)		38 to 46	38, 46	OFDM	BPSK	13.0
-	802.11ac (80MHz)		42	42	OFDM	BPSK	29.3
-	802.11ac (20MHz)	5745-5825	149 to 165	149, 157, 165	OFDM	BPSK	6.5
-	802.11ac (40MHz)		151 to 159	151, 159	OFDM	BPSK	13.0
-	802.11ac (80MHz)		155	155	OFDM	BPSK	29.3

Radiated Emission Test (Below 1GHz):

- Pre-Scan has been conducted to determine the worst-case mode from all possible combinations between available modulations, data rates and antenna ports (if EUT with antenna diversity architecture).
- Following channel(s) was (were) selected for the final test as listed below.

CDD Mode							
EUT CONFIGURE MODE	MODE	FREQ. BAND (MHz)	AVAILABLE CHANNEL	TESTED CHANNEL	MODULATION TECHNOLOGY	MODULATION TYPE	DATA RATE (Mbps)
-	802.11ac (40MHz)	5180-5240	38 to 46	46	OFDM	BPSK	13.0
-	802.11ac (40MHz)	5745-5825	151 to 159		OFDM	BPSK	13.0

Power Line Conducted Emission Test:

- Pre-Scan has been conducted to determine the worst-case mode from all possible combinations between available modulations, data rates and antenna ports (if EUT with antenna diversity architecture).
- Following channel(s) was (were) selected for the final test as listed below.

CDD Mode							
EUT CONFIGURE MODE	MODE	FREQ. BAND (MHz)	AVAILABLE CHANNEL	TESTED CHANNEL	MODULATION TECHNOLOGY	MODULATION TYPE	DATA RATE (Mbps)
-	802.11ac (40MHz)	5180-5240	38 to 46	46	OFDM	BPSK	13.0
-	802.11ac (40MHz)	5745-5825	151 to 159		OFDM	BPSK	13.0

Antenna Port Conducted Measurement:

- This item includes all test value of each mode, but only includes spectrum plot of worst value of each mode.
- Pre-Scan has been conducted to determine the worst-case mode from all possible combinations between available modulations, data rates and antenna ports (if EUT with antenna diversity architecture).
- Following channel(s) was (were) selected for the final test as listed below.

CDD Mode							
EUT CONFIGURE MODE	MODE	FREQ. BAND (MHz)	AVAILABLE CHANNEL	TESTED CHANNEL	MODULATION TECHNOLOGY	MODULATION TYPE	DATA RATE (Mbps)
-	802.11a	5180-5240	36 to 48	36, 40, 48	OFDM	BPSK	6.0
-	802.11ac (20MHz)		36 to 48	36, 40, 48	OFDM	BPSK	6.5
-	802.11ac (40MHz)		38 to 46	38, 46	OFDM	BPSK	13.0
-	802.11ac (80MHz)		42	42	OFDM	BPSK	29.3
-	802.11a	5745-5825	149 to 165	149, 157, 165	OFDM	BPSK	6.0
-	802.11ac (20MHz)		149 to 165	149, 157, 165	OFDM	BPSK	6.5
-	802.11ac (40MHz)		151 to 159	151, 159	OFDM	BPSK	13.0
-	802.11ac (80MHz)		155	155	OFDM	BPSK	29.3
Beamforming Mode							
EUT CONFIGURE MODE	MODE	FREQ. BAND (MHz)	AVAILABLE CHANNEL	TESTED CHANNEL	MODULATION TECHNOLOGY	MODULATION TYPE	DATA RATE (Mbps)
-	802.11ac (20MHz)	5180-5240	36 to 48	36, 40, 48	OFDM	BPSK	6.5
-	802.11ac (40MHz)		38 to 46	38, 46	OFDM	BPSK	13.0
-	802.11ac (80MHz)		42	42	OFDM	BPSK	29.3
-	802.11ac (20MHz)	5745-5825	149 to 165	149, 157, 165	OFDM	BPSK	6.5
-	802.11ac (40MHz)		151 to 159	151, 159	OFDM	BPSK	13.0
-	802.11ac (80MHz)		155	155	OFDM	BPSK	29.3

Test Condition:

APPLICABLE TO	ENVIRONMENTAL CONDITIONS	INPUT POWER	TESTED BY
RE \geq 1G	17deg. C, 69%RH	120Vac, 60Hz	Aaron You
RE $<$ 1G	15deg. C, 73%RH	120Vac, 60Hz	Aaron You
PLC	23deg. C, 69%RH	120Vac, 60Hz	Ian Chang
APCM	25deg. C, 60%RH	120Vac, 60Hz	Dalen Dai

3.3 Duty Cycle of Test Signal

Duty cycle of test signal is < 98 %, duty factor is required

802.11a: Duty cycle = $1.376/1.710 = 0.805$, Duty factor = $10 * \log(1/0.805) = 0.94$

802.11ac (20MHz): Duty cycle = $0.356/0.666 = 0.535$, Duty factor = $10 * \log(1/0.535) = 2.72$

802.11ac (40MHz): Duty cycle = $0.194/0.513 = 0.378$, Duty factor = $10 * \log(1/0.378) = 4.22$

802.11ac (80MHz): Duty cycle = $0.086/0.449 = 0.192$, Duty factor = $10 * \log(1/0.192) = 7.18$

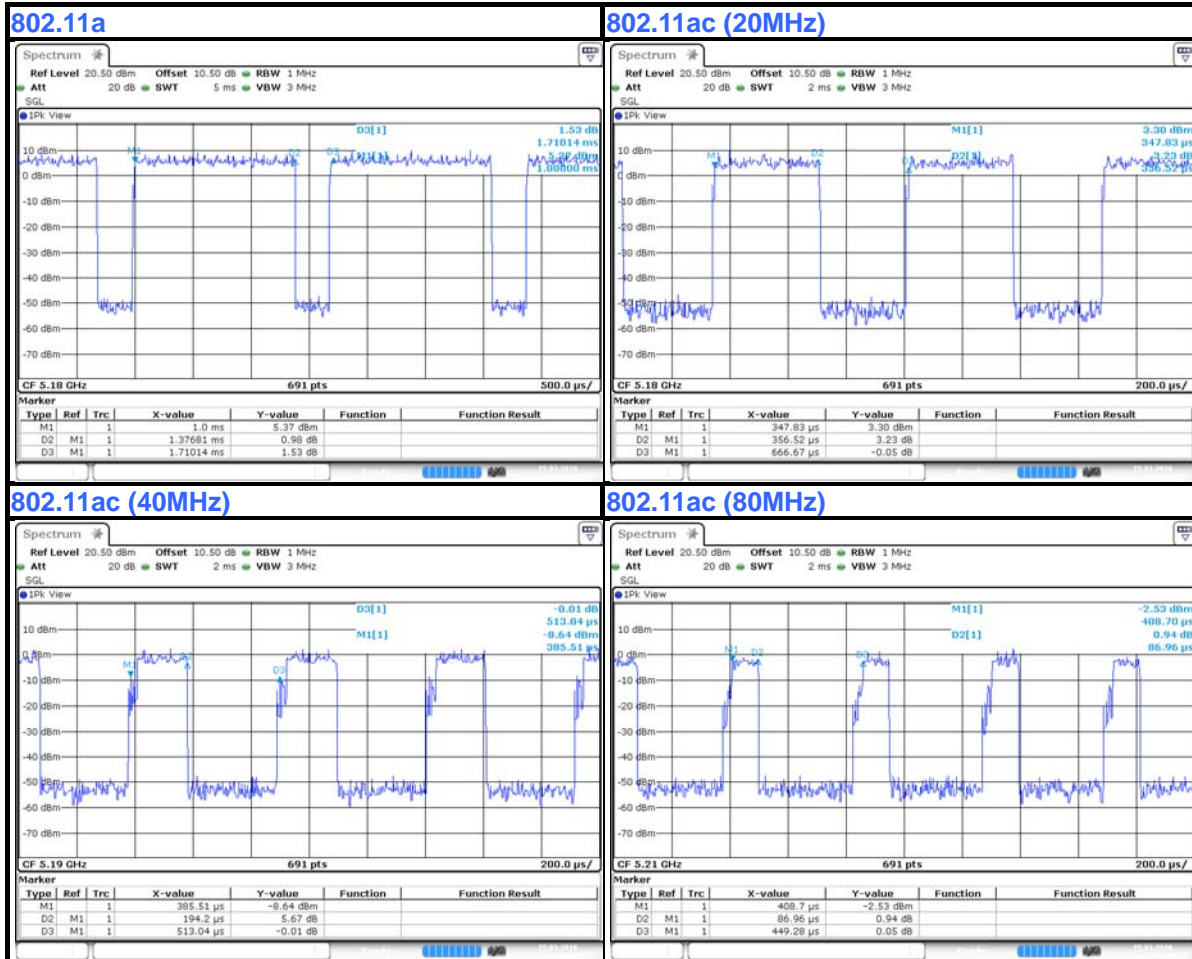

3.4 Description of Support Units

The EUT has been tested as an independent unit together with other necessary accessories or support units. The following support units or accessories were used to form a representative test configuration during the tests.

ID	Product	Brand	Model No.	Serial No.	FCC ID	Remarks
A.	Notebook	DELL	PP27L	8SNZ12S	FCC DoC Approved	Provided by Lab

Note:

1. All power cords of the above support units are non-shielded (1.8m).
2. Item A acted as communication partners to transfer data.

ID	Descriptions	Qty.	Length (m)	Shielding (Yes/No)	Cores (Qty.)	Remarks
1.	RJ45 cable	1	10	N	0	Provided by Lab

Note: The core(s) is(are) originally attached to the cable(s).

3.4.1 Configuration of System under Test

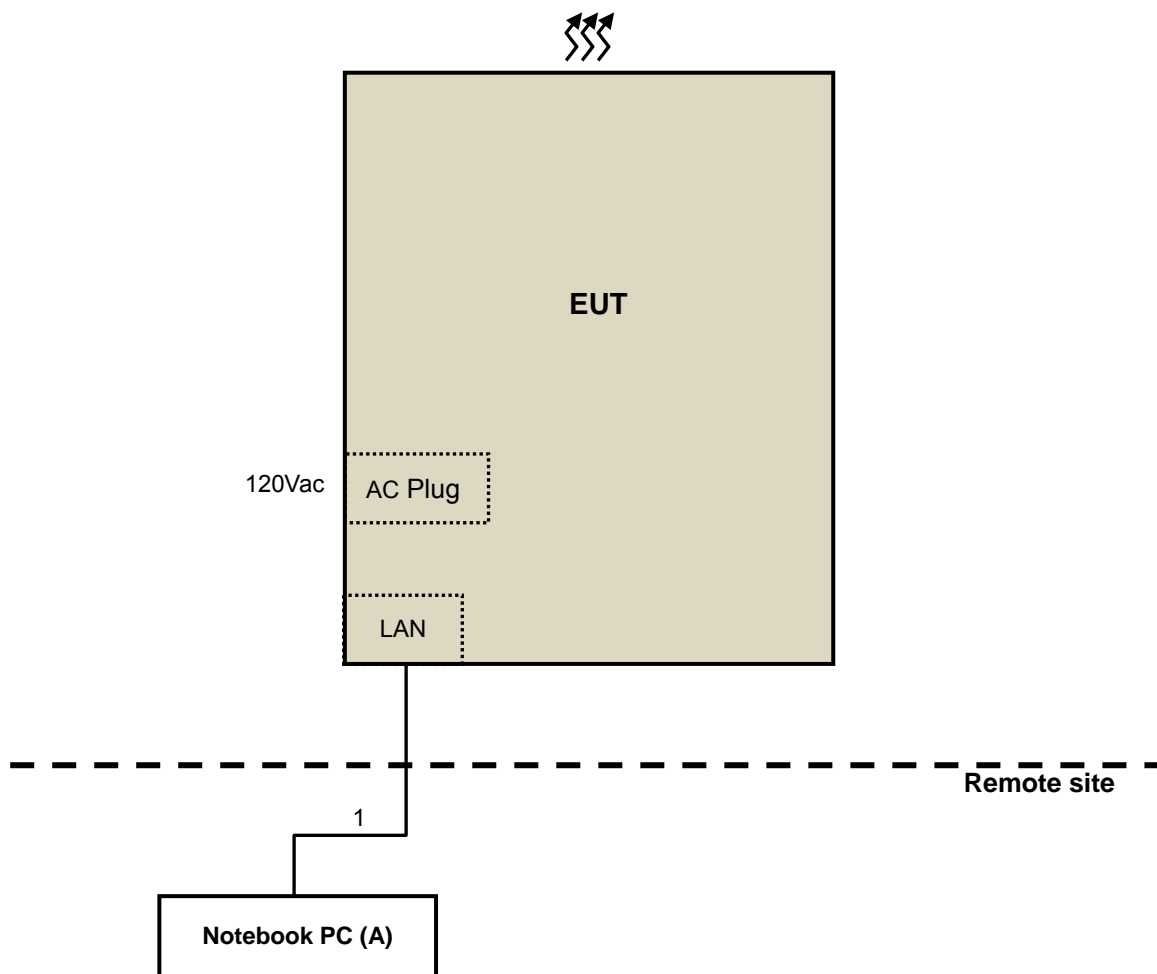

3.5 General Description of Applied Standard

The EUT is a RF Product. According to the specifications of the manufacturer, it must comply with the requirements of the following standards:

FCC Part 15, Subpart E (15.407)

KDB 789033 D02 General UNII Test Procedure New Rules v01r02

KDB 662911 D01 Multiple Transmitter Output v02r01

ANSI C63.10-2013

All test items have been performed and recorded as per the above standards.

4 Test Types and Results

4.1 Radiated Emission and Bandedge Measurement

4.1.1 Limits of Radiated Emission and Bandedge Measurement

Radiated emissions which fall in the restricted bands must comply with the radiated emission limits specified as below table.

Frequencies (MHz)	Field Strength (microvolts/meter)	Measurement Distance (meters)
0.009 ~ 0.490	2400/F(kHz)	300
0.490 ~ 1.705	24000/F(kHz)	30
1.705 ~ 30.0	30	30
30 ~ 88	100	3
88 ~ 216	150	3
216 ~ 960	200	3
Above 960	500	3

NOTE:

1. The lower limit shall apply at the transition frequencies.
2. Emission level (dBuV/m) = 20 log Emission level (uV/m).
3. For frequencies above 1000MHz, the field strength limits are based on average detector, however, the peak field strength of any emission shall not exceed the maximum permitted average limits, specified above by more than 20dB under any condition of modulation.

Limits Of Unwanted Emission Out Of The Restricted Bands

Applicable To	Limit	
789033 D02 General UNII Test Procedure New Rules v01r02	FIELD STRENGTH at 3m	
	PK:74 (dBuV/m)	AV:54 (dBuV/m)
Applicable To	EIRP Limit	Equivalent Field Strength at 3m
15.407(b)(1)	PK:-27 (dBm/MHz)	PK:68.2(dBμV/m)
15.407(b)(2)		
15.407(b)(3)		
15.407(b)(4)(i)	PK:-27 (dBm/MHz) ^{*1} PK:10 (dBm/MHz) ^{*2} PK:15.6 (dBm/MHz) ^{*3} PK:27 (dBm/MHz) ^{*4}	PK: 68.2(dBμV/m) ^{*1} PK:105.2 (dBμV/m) ^{*2} PK: 110.8(dBμV/m) ^{*3} PK:122.2 (dBμV/m) ^{*4}
15.407(b)(4)(ii)	FIELD STRENGTH at 3m / § 15.247(d),	
	PK:74 (dBμV/m)	AV:54 (dBμV/m)
^{*1} beyond 75 MHz or more above of the band edge.		^{*2} below the band edge increasing linearly to 10 dBm/MHz at 25 MHz above.
^{*3} below the band edge increasing linearly to a level of 15.6 dBm/MHz at 5 MHz above.		^{*4} from 5 MHz above or below the band edge increasing linearly to a level of 27 dBm/MHz at the band edge.

NOTE: The following formula is used to convert the equipment isotropic radiated power (eirp) to field strength:

$$E = \frac{1000000\sqrt{30P}}{3} \quad \mu\text{V/m, where P is the eirp (Watts).}$$

4.1.2 Test Instruments

DESCRIPTION & MANUFACTURER	MODEL NO.	SERIAL NO.	CALIBRATED DATE	CALIBRATED UNTIL
HP Preamplifier	8447D	2432A03504	Feb. 26, 2016	Feb. 25, 2017
HP Preamplifier	8449B	3008A01201	Feb. 26, 2016	Feb. 25, 2017
MITEQ Preamplifier	AMF-6F-260400-33-8P	892164	Mar. 01, 2016	Feb. 28, 2017
Agilent TEST RECEIVER	N9038A	MY51210129	Feb. 02, 2016	Feb. 01, 2017
Schwarzbeck Antenna	VULB 9168	139	Jan. 04, 2016	Jan. 03, 2017
Schwarzbeck Antenna	VHBA 9123	480	May 29, 2015	May 28, 2017
Schwarzbeck Horn Antenna	BBHA-9170	212	Jan. 08, 2016	Jan. 07, 2017
Schwarzbeck Horn Antenna	BBHA 9120-D1	D130	Jan. 21, 2016	Jan. 20, 2017
ADT. Turn Table	TT100	0306	NA	NA
ADT. Tower	AT100	0306	NA	NA
Software	Radiated_V7.6.15.9.4	NA	NA	NA
SUHNER RF cable With 4dB PAD	SF104	CABLE-CH6	Aug. 15, 2015	Aug. 14, 2016
SUHNER RF cable With 3dB PAD	SF102	Cable-CH8-3.6m	Aug. 15, 2015	Aug. 14, 2016
KEYSIGHT MIMO Powermeasurement Test set	U2021XA	U2021XA-001	May 04, 2015	May 03, 2016
KEYSIGHT Spectrum Analyzer	N9030A	MY54490260	Jul. 14, 2015	Jul. 13, 2016
EMCO Horn Antenna	3115	00028257	Jan. 19, 2016	Jan. 18, 2017
Highpass filter Wainwright Instruments	WHK 3.1/18G-10SS	SN 8	NA	NA
ROHDE & SCHWARZ Spectrum Analyzer	FSV40	101042	Sep. 23, 2015	Sep. 22, 2016
Anritsu Power Sensor	MA2411B	0738404	Apr. 21, 2015	Apr. 20, 2016
Anritsu Power Meter	ML2495A	0842014	Apr. 21, 2015	Apr. 20, 2016
Temperature & Humidity Chamber	MHU-225AU	920409	May 25, 2015	May 24, 2016
DIGITAL POWER METER IDRC	CP-240	240515	Sep. 10, 2015	Sep. 9, 2016
AC Power Source ExTech	CFW-105	E000603	NA	NA

- NOTE:** 1. The calibration interval of the above test instruments is 12/24 months. And the calibrations are traceable to NML/ROC and NIST/USA.
2. The horn antenna and HP preamplifier (model: 8449B) are used only for the measurement of emission frequency above 1GHz if tested.
3. The test was performed in Chamber No. 6.
4. The Industry Canada Reference No. IC 7450E-6.
5. The FCC Site Registration No. is 447212.

4.1.3 Test Procedure

- a. The EUT was placed on the top of a rotating table 0.8 meters (for below 1GHz) / 1.5 meters (for above 1GHz) above the ground at 3 meter chamber room for test. The table was rotated 360 degrees to determine the position of the highest radiation.
- b. The EUT was set 3 meters away from the interference-receiving antenna, which was mounted on the top of a variable-height antenna tower.
- c. The height of antenna is varied from one meter to four meters above the ground to determine the maximum value of the field strength. Both horizontal and vertical polarizations of the antenna are set to make the measurement.
- d. For each suspected emission, the EUT was arranged to its worst case and then the antenna was tuned to heights from 1 meter to 4 meters and the rotatable table was turned from 0 degrees to 360 degrees to find the maximum reading.
- e. The test-receiver system was set to quasi-peak detect function and specified bandwidth with maximum hold mode when the test frequency is below 1 GHz.
- f. The test-receiver system was set to peak and average detect function and specified bandwidth with maximum hold mode when the test frequency is above 1 GHz. If the peak reading value also meets average limit, measurement with the average detector is unnecessary.

Note:

1. The resolution bandwidth and video bandwidth of test receiver/spectrum analyzer is 120kHz for Quasi-peak detection (QP) at frequency below 1GHz.
2. The resolution bandwidth of test receiver/spectrum analyzer is 1 MHz and the video bandwidth is 3 MHz for Peak detection (PK) at frequency above 1GHz.
3. The resolution bandwidth of test receiver/spectrum analyzer is 1MHz and the video bandwidth is 3MHz for RMS Average (Duty cycle < 98%) for Average detection (AV) at frequency above 1GHz, then the measurement results was added to a correction factor ($10 \log(1/\text{duty cycle})$).
4. All modes of operation were investigated and the worst-case emissions are reported.

4.1.4 Deviation from Test Standard

No deviation.

4.1.5 Test Setup

<Frequency Range below 1GHz>

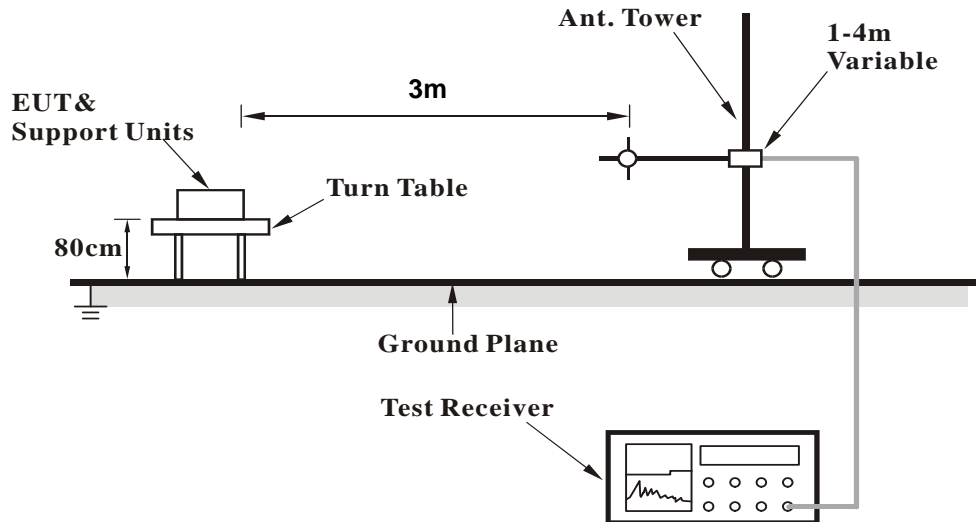

<Frequency Range above 1GHz>

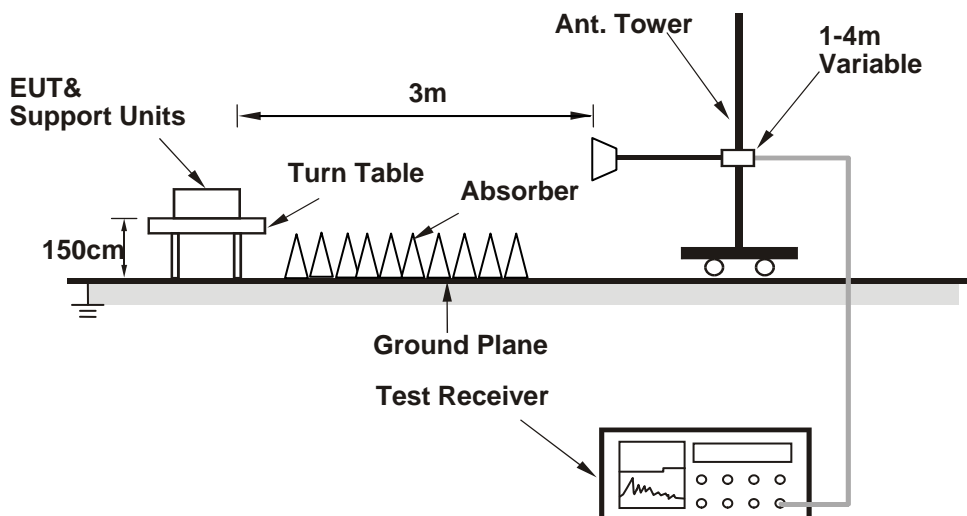

For the actual test configuration, please refer to the attached file (Test Setup Photo).

4.1.6 EUT Operating Condition

- Placed the EUT on the testing table.
- Prepared notebooks to act as communication partner and placed it outside of testing area.
- The communication partner connected with EUT via a RJ45 cable and ran a test program (provided by manufacturer) to enable EUT under transmission condition continuously at specific channel frequency.
- The communication partner sent data to EUT by command "PING".
- The necessary accessories enable the system in full functions.

4.1.7 Test Results

ABOVE 1GHz DATA

CDD Mode

802.11a

CHANNEL	TX Channel 36	DETECTOR FUNCTION	Peak (PK)
FREQUENCY RANGE	1GHz ~ 40GHz		Average (AV)

ANTENNA POLARITY & TEST DISTANCE: HORIZONTAL AT 3 M								
NO.	FREQ. (MHz)	EMISSION LEVEL (dBuV/m)	LIMIT (dBuV/m)	MARGIN (dB)	ANTENNA HEIGHT (m)	TABLE ANGLE (Degree)	RAW VALUE (dBuV)	CORRECTION FACTOR (dB/m)
1	5150.00	70.3 PK	74.0	-3.7	2.32 H	92	61.80	8.53
2	5150.00	52.7 AV	54.0	-1.3	2.32 H	92	44.15	8.53
3	*5180.00	118.1 PK			2.32 H	92	109.43	8.71
4	*5180.00	108.0 AV			2.32 H	92	99.26	8.71
5	#10360.00	61.1 PK	74.0	-12.9	1.48 H	360	40.75	20.33
6	#10360.00	48.2 AV	54.0	-5.8	1.48 H	360	27.87	20.33

ANTENNA POLARITY & TEST DISTANCE: VERTICAL AT 3 M								
NO.	FREQ. (MHz)	EMISSION LEVEL (dBuV/m)	LIMIT (dBuV/m)	MARGIN (dB)	ANTENNA HEIGHT (m)	TABLE ANGLE (Degree)	RAW VALUE (dBuV)	CORRECTION FACTOR (dB/m)
1	5150.00	63.8 PK	74.0	-10.2	1.57 V	52	55.27	8.53
2	5150.00	48.4 AV	54.0	-5.6	1.57 V	52	39.87	8.53
3	*5180.00	110.4 PK			1.57 V	52	101.72	8.71
4	*5180.00	99.9 AV			1.57 V	52	91.23	8.71
5	#10360.00	59.7 PK	74.0	-14.4	2.04 V	49	39.32	20.33
6	#10360.00	47.0 AV	54.0	-7.0	2.04 V	49	26.67	20.33

REMARKS:

- Emission Level(dBuV/m) = Raw Value(dBuV) + Correction Factor(dB/m)
- Correction Factor(dB/m) = Antenna Factor(dB/m) + Cable Factor(dB) – Pre-Amplifier Factor(dB)
- The other emission levels were very low against the limit.
- Margin value = Emission Level – Limit value
- " * ": Fundamental frequency.
- " # ": The radiated frequency is out of the restricted band.

CHANNEL	TX Channel 40	DETECTOR FUNCTION	Peak (PK)
FREQUENCY RANGE	1GHz ~ 40GHz		Average (AV)

ANTENNA POLARITY & TEST DISTANCE: HORIZONTAL AT 3 M								
---	--	--	--	--	--	--	--	--

NO.	FREQ. (MHz)	EMISSION LEVEL (dBuV/m)	LIMIT (dBuV/m)	MARGIN (dB)	ANTENNA HEIGHT (m)	TABLE ANGLE (Degree)	RAW VALUE (dBuV)	CORRECTION FACTOR (dB/m)
1	*5200.00	116.2 PK			1.91 H	104	107.33	8.82
2	*5200.00	105.6 AV			1.91 H	104	96.81	8.82
3	#10400.00	62.2 PK	74.0	-11.9	1.67 H	254	41.69	20.46
4	#10400.00	48.2 AV	54.0	-5.9	1.67 H	254	27.69	20.46

ANTENNA POLARITY & TEST DISTANCE: VERTICAL AT 3 M								
---	--	--	--	--	--	--	--	--

NO.	FREQ. (MHz)	EMISSION LEVEL (dBuV/m)	LIMIT (dBuV/m)	MARGIN (dB)	ANTENNA HEIGHT (m)	TABLE ANGLE (Degree)	RAW VALUE (dBuV)	CORRECTION FACTOR (dB/m)
1	*5200.00	111.4 PK			3.99 V	314	102.53	8.82
2	*5200.00	102.2 AV			3.99 V	314	93.34	8.82
3	#10400.00	60.7 PK	74.0	-13.3	1.74 V	39	40.25	20.46
4	#10400.00	47.5 AV	54.0	-6.5	1.74 V	39	27.02	20.46

REMARKS:

1. Emission Level(dBuV/m) = Raw Value(dBuV) + Correction Factor(dB/m)
2. Correction Factor(dB/m) = Antenna Factor(dB/m) + Cable Factor(dB) – Pre-Amplifier Factor(dB)
3. The other emission levels were very low against the limit.
4. Margin value = Emission Level – Limit value
5. " * ": Fundamental frequency.
6. " # ": The radiated frequency is out of the restricted band.

CHANNEL	TX Channel 48	DETECTOR FUNCTION	Peak (PK)
FREQUENCY RANGE	1GHz ~ 40GHz		Average (AV)

ANTENNA POLARITY & TEST DISTANCE: HORIZONTAL AT 3 M

NO.	FREQ. (MHz)	EMISSION LEVEL (dBuV/m)	LIMIT (dBuV/m)	MARGIN (dB)	ANTENNA HEIGHT (m)	TABLE ANGLE (Degree)	RAW VALUE (dBuV)	CORRECTION FACTOR (dB/m)
1	*5240.00	116.7 PK			2.44 H	76	107.74	8.97
2	*5240.00	107.3 AV			2.44 H	76	98.37	8.97
3	5350.00	61.9 PK	74.0	-12.1	2.44 H	76	52.43	9.43
4	5350.00	46.9 AV	54.0	-7.1	2.44 H	76	37.51	9.43
5	#10480.00	61.7 PK	74.0	-12.3	1.89 H	46	40.79	20.89
6	#10480.00	48.8 AV	54.0	-5.2	1.89 H	46	27.89	20.89

ANTENNA POLARITY & TEST DISTANCE: VERTICAL AT 3 M

NO.	FREQ. (MHz)	EMISSION LEVEL (dBuV/m)	LIMIT (dBuV/m)	MARGIN (dB)	ANTENNA HEIGHT (m)	TABLE ANGLE (Degree)	RAW VALUE (dBuV)	CORRECTION FACTOR (dB/m)
1	*5240.00	109.9 PK			2.62 V	290	100.91	8.97
2	*5240.00	99.8 AV			2.62 V	290	90.85	8.97
3	5350.00	61.2 PK	74.0	-12.8	2.62 V	290	51.78	9.43
4	5350.00	46.5 AV	54.0	-7.5	2.62 V	290	37.08	9.43
5	#10480.00	60.6 PK	74.0	-13.4	2.37 V	154	39.68	20.89
6	#10480.00	47.7 AV	54.0	-6.3	2.37 V	154	26.84	20.89

REMARKS:

- Emission Level(dBuV/m) = Raw Value(dBuV) + Correction Factor(dB/m)
- Correction Factor(dB/m) = Antenna Factor(dB/m) + Cable Factor(dB) – Pre-Amplifier Factor(dB)
- The other emission levels were very low against the limit.
- Margin value = Emission Level – Limit value
- " * ": Fundamental frequency.
- " # ": The radiated frequency is out of the restricted band.

CHANNEL	TX Channel 149	DETECTOR FUNCTION	Peak (PK)
FREQUENCY RANGE	1GHz ~ 40GHz		Average (AV)

ANTENNA POLARITY & TEST DISTANCE: HORIZONTAL AT 3 M

NO.	FREQ. (MHz)	EMISSION LEVEL (dBuV/m)	LIMIT (dBuV/m)	MARGIN (dB)	ANTENNA HEIGHT (m)	TABLE ANGLE (Degree)	RAW VALUE (dBuV)	CORRECTION FACTOR (dB/m)
1	#5649.99	62.2 PK	68.2	-6.0	1.62 H	53	53.53	8.64
2	*5745.00	115.0 PK			1.62 H	53	106.59	8.43
3	*5745.00	104.9 AV			1.62 H	53	96.45	8.43
4	11490.00	58.1 PK	74.0	-15.9	1.20 H	95	39.47	18.65
5	11490.00	44.4 AV	54.0	-9.6	1.20 H	95	25.79	18.65

ANTENNA POLARITY & TEST DISTANCE: VERTICAL AT 3 M

NO.	FREQ. (MHz)	EMISSION LEVEL (dBuV/m)	LIMIT (dBuV/m)	MARGIN (dB)	ANTENNA HEIGHT (m)	TABLE ANGLE (Degree)	RAW VALUE (dBuV)	CORRECTION FACTOR (dB/m)
1	#5649.99	59.9 PK	68.2	-8.3	1.50 V	137	51.27	8.64
2	*5745.00	106.9 PK			1.50 V	137	98.51	8.43
3	*5745.00	96.7 AV			1.50 V	137	88.30	8.43
4	11490.00	57.7 PK	74.0	-16.3	1.09 V	227	39.06	18.65
5	11490.00	44.0 AV	54.0	-10.0	1.09 V	227	25.31	18.65

REMARKS:

1. Emission Level(dBuV/m) = Raw Value(dBuV) + Correction Factor(dB/m)
2. Correction Factor(dB/m) = Antenna Factor(dB/m) + Cable Factor(dB) – Pre-Amplifier Factor(dB)
3. The other emission levels were very low against the limit.
4. Margin value = Emission Level – Limit value
5. " * ": Fundamental frequency.
6. " # ": The radiated frequency is out of the restricted band.

CHANNEL	TX Channel 157	DETECTOR FUNCTION	Peak (PK)
FREQUENCY RANGE	1GHz ~ 40GHz		Average (AV)

ANTENNA POLARITY & TEST DISTANCE: HORIZONTAL AT 3 M								
---	--	--	--	--	--	--	--	--

NO.	FREQ. (MHz)	EMISSION LEVEL (dBuV/m)	LIMIT (dBuV/m)	MARGIN (dB)	ANTENNA HEIGHT (m)	TABLE ANGLE (Degree)	RAW VALUE (dBuV)	CORRECTION FACTOR (dB/m)
1	*5785.00	115.3 PK			1.66 H	54	106.94	8.34
2	*5785.00	105.0 AV			1.66 H	54	96.69	8.34
3	11570.00	58.4 PK	74.0	-15.6	1.22 H	93	39.62	18.81
4	11570.00	44.6 AV	54.0	-9.4	1.22 H	93	25.83	18.81

ANTENNA POLARITY & TEST DISTANCE: VERTICAL AT 3 M								
---	--	--	--	--	--	--	--	--

NO.	FREQ. (MHz)	EMISSION LEVEL (dBuV/m)	LIMIT (dBuV/m)	MARGIN (dB)	ANTENNA HEIGHT (m)	TABLE ANGLE (Degree)	RAW VALUE (dBuV)	CORRECTION FACTOR (dB/m)
1	*5785.00	107.4 PK			1.47 V	139	99.02	8.34
2	*5785.00	107.0 AV			1.47 V	139	98.64	8.34
3	11570.00	57.7 PK	74.0	-16.3	1.11 V	230	38.89	18.81
4	11570.00	44.3 AV	54.0	-9.7	1.11 V	230	25.51	18.81

REMARKS:

1. Emission Level(dBuV/m) = Raw Value(dBuV) + Correction Factor(dB/m)
2. Correction Factor(dB/m) = Antenna Factor(dB/m) + Cable Factor(dB) – Pre-Amplifier Factor(dB)
3. The other emission levels were very low against the limit.
4. Margin value = Emission Level – Limit value
5. " * " : Fundamental frequency.

CHANNEL	TX Channel 165	DETECTOR FUNCTION	Peak (PK)
FREQUENCY RANGE	1GHz ~ 40GHz		Average (AV)

ANTENNA POLARITY & TEST DISTANCE: HORIZONTAL AT 3 M

NO.	FREQ. (MHz)	EMISSION LEVEL (dBuV/m)	LIMIT (dBuV/m)	MARGIN (dB)	ANTENNA HEIGHT (m)	TABLE ANGLE (Degree)	RAW VALUE (dBuV)	CORRECTION FACTOR (dB/m)
1	*5825.00	114.7 PK			1.67 H	56	106.35	8.33
2	*5825.00	104.4 AV			1.67 H	56	96.08	8.33
3	#5925.01	61.6 PK	68.2	-6.6	1.67 H	56	53.13	8.50
4	11650.00	58.1 PK	74.0	-15.9	1.16 H	90	39.52	18.59
5	11650.00	44.3 AV	54.0	-9.7	1.16 H	90	25.67	18.59

ANTENNA POLARITY & TEST DISTANCE: VERTICAL AT 3 M

NO.	FREQ. (MHz)	EMISSION LEVEL (dBuV/m)	LIMIT (dBuV/m)	MARGIN (dB)	ANTENNA HEIGHT (m)	TABLE ANGLE (Degree)	RAW VALUE (dBuV)	CORRECTION FACTOR (dB/m)
1	*5825.00	106.1 PK			1.49 V	136	97.81	8.33
2	*5825.00	95.9 AV			1.49 V	136	87.54	8.33
3	#5925.01	59.8 PK	68.2	-8.4	1.49 V	136	51.34	8.50
4	11650.00	57.7 PK	74.0	-16.3	1.05 V	92	39.15	18.59
5	11650.00	44.0 AV	54.0	-10.1	1.05 V	92	25.36	18.59

REMARKS:

- Emission Level(dBuV/m) = Raw Value(dBuV) + Correction Factor(dB/m)
- Correction Factor(dB/m) = Antenna Factor(dB/m) + Cable Factor(dB) – Pre-Amplifier Factor(dB)
- The other emission levels were very low against the limit.
- Margin value = Emission Level – Limit value
- " * ": Fundamental frequency.
- " # ": The radiated frequency is out of the restricted band.

802.11ac (20MHz)

CHANNEL	TX Channel 36	DETECTOR FUNCTION	Peak (PK)
FREQUENCY RANGE	1GHz ~ 40GHz		Average (AV)

ANTENNA POLARITY & TEST DISTANCE: HORIZONTAL AT 3 M

NO.	FREQ. (MHz)	EMISSION LEVEL (dBuV/m)	LIMIT (dBuV/m)	MARGIN (dB)	ANTENNA HEIGHT (m)	TABLE ANGLE (Degree)	RAW VALUE (dBuV)	CORRECTION FACTOR (dB/m)
1	5150.00	70.0 PK	74.0	-4.0	2.08 H	93	61.47	8.53
2	5150.00	51.8 AV	54.0	-2.2	2.08 H	93	43.25	8.53
3	*5180.00	116.3 PK			2.08 H	93	107.55	8.71
4	*5180.00	103.9 AV			2.08 H	93	95.20	8.71
5	#10360.00	61.6 PK	74.0	-12.4	2.33 H	64	41.26	20.33
6	#10360.00	48.0 AV	54.0	-6.0	2.33 H	64	27.64	20.33

ANTENNA POLARITY & TEST DISTANCE: VERTICAL AT 3 M

NO.	FREQ. (MHz)	EMISSION LEVEL (dBuV/m)	LIMIT (dBuV/m)	MARGIN (dB)	ANTENNA HEIGHT (m)	TABLE ANGLE (Degree)	RAW VALUE (dBuV)	CORRECTION FACTOR (dB/m)
1	5150.00	64.9 PK	74.0	-9.2	3.79 V	51	56.32	8.53
2	5150.00	48.5 AV	54.0	-5.5	3.79 V	51	39.98	8.53
3	*5180.00	110.2 PK			3.79 V	51	101.51	8.71
4	*5180.00	99.4 AV			3.79 V	51	90.66	8.71
5	#10360.00	61.2 PK	74.0	-12.8	1.76 V	47	40.86	20.33
6	#10360.00	46.9 AV	54.0	-7.1	1.76 V	47	26.54	20.33

REMARKS:

- Emission Level(dBuV/m) = Raw Value(dBuV) + Correction Factor(dB/m)
- Correction Factor(dB/m) = Antenna Factor(dB/m) + Cable Factor(dB) – Pre-Amplifier Factor(dB)
- The other emission levels were very low against the limit.
- Margin value = Emission Level – Limit value
- " * ": Fundamental frequency.
- " # ": The radiated frequency is out of the restricted band.

CHANNEL	TX Channel 40	DETECTOR FUNCTION	Peak (PK)
FREQUENCY RANGE	1GHz ~ 40GHz		Average (AV)

ANTENNA POLARITY & TEST DISTANCE: HORIZONTAL AT 3 M								
---	--	--	--	--	--	--	--	--

NO.	FREQ. (MHz)	EMISSION LEVEL (dBuV/m)	LIMIT (dBuV/m)	MARGIN (dB)	ANTENNA HEIGHT (m)	TABLE ANGLE (Degree)	RAW VALUE (dBuV)	CORRECTION FACTOR (dB/m)
1	*5200.00	116.1 PK			1.51 H	319	107.25	8.82
2	*5200.00	103.3 AV			1.51 H	319	94.48	8.82
3	#10400.00	61.6 PK	74.0	-12.4	1.68 H	55	41.15	20.46
4	#10400.00	48.1 AV	54.0	-5.9	1.68 H	55	27.63	20.46

ANTENNA POLARITY & TEST DISTANCE: VERTICAL AT 3 M								
---	--	--	--	--	--	--	--	--

NO.	FREQ. (MHz)	EMISSION LEVEL (dBuV/m)	LIMIT (dBuV/m)	MARGIN (dB)	ANTENNA HEIGHT (m)	TABLE ANGLE (Degree)	RAW VALUE (dBuV)	CORRECTION FACTOR (dB/m)
1	*5200.00	109.0 PK			1.43 V	336	100.19	8.82
2	*5200.00	97.7 AV			1.43 V	336	88.88	8.82
3	#10400.00	60.5 PK	74.0	-13.5	2.96 V	158	40.02	20.46
4	#10400.00	47.0 AV	54.0	-7.0	2.96 V	158	26.56	20.46

REMARKS:

1. Emission Level(dBuV/m) = Raw Value(dBuV) + Correction Factor(dB/m)
2. Correction Factor(dB/m) = Antenna Factor(dB/m) + Cable Factor(dB) – Pre-Amplifier Factor(dB)
3. The other emission levels were very low against the limit.
4. Margin value = Emission Level – Limit value
5. " * ": Fundamental frequency.
6. " # ": The radiated frequency is out of the restricted band.

CHANNEL	TX Channel 48	DETECTOR FUNCTION	Peak (PK)
FREQUENCY RANGE	1GHz ~ 40GHz		Average (AV)

ANTENNA POLARITY & TEST DISTANCE: HORIZONTAL AT 3 M

NO.	FREQ. (MHz)	EMISSION LEVEL (dBuV/m)	LIMIT (dBuV/m)	MARGIN (dB)	ANTENNA HEIGHT (m)	TABLE ANGLE (Degree)	RAW VALUE (dBuV)	CORRECTION FACTOR (dB/m)
1	*5240.00	116.6 PK			2.65 H	77	107.65	8.97
2	*5240.00	104.0 AV			2.65 H	77	94.98	8.97
3	5350.00	61.5 PK	74.0	-12.5	2.65 H	77	52.10	9.43
4	5350.00	46.8 AV	54.0	-7.2	2.65 H	77	37.36	9.43
5	#10480.00	62.0 PK	74.0	-12.0	1.80 H	315	41.11	20.89
6	#10480.00	47.9 AV	54.0	-6.1	1.80 H	315	27.03	20.89

ANTENNA POLARITY & TEST DISTANCE: VERTICAL AT 3 M

NO.	FREQ. (MHz)	EMISSION LEVEL (dBuV/m)	LIMIT (dBuV/m)	MARGIN (dB)	ANTENNA HEIGHT (m)	TABLE ANGLE (Degree)	RAW VALUE (dBuV)	CORRECTION FACTOR (dB/m)
1	*5240.00	108.5 PK			3.14 V	336	99.54	8.97
2	*5240.00	98.2 AV			3.14 V	336	89.25	8.97
3	5350.00	60.8 PK	74.0	-13.2	3.14 V	336	51.38	9.43
4	5350.00	46.7 AV	54.0	-7.3	3.14 V	336	37.24	9.43
5	#10480.00	60.9 PK	74.0	-13.1	1.99 V	17	40.05	20.89
6	#10480.00	47.4 AV	54.0	-6.6	1.99 V	17	26.53	20.89

REMARKS:

- Emission Level(dBuV/m) = Raw Value(dBuV) + Correction Factor(dB/m)
- Correction Factor(dB/m) = Antenna Factor(dB/m) + Cable Factor(dB) – Pre-Amplifier Factor(dB)
- The other emission levels were very low against the limit.
- Margin value = Emission Level – Limit value
- " * ": Fundamental frequency.
- " # ": The radiated frequency is out of the restricted band.

CHANNEL	TX Channel 149	DETECTOR FUNCTION	Peak (PK)
FREQUENCY RANGE	1GHz ~ 40GHz		Average (AV)

ANTENNA POLARITY & TEST DISTANCE: HORIZONTAL AT 3 M

NO.	FREQ. (MHz)	EMISSION LEVEL (dBuV/m)	LIMIT (dBuV/m)	MARGIN (dB)	ANTENNA HEIGHT (m)	TABLE ANGLE (Degree)	RAW VALUE (dBuV)	CORRECTION FACTOR (dB/m)
1	#5649.99	61.8 PK	68.2	-6.4	1.47 H	52	53.17	8.64
2	*5745.00	112.8 PK			1.47 H	52	104.36	8.43
3	*5745.00	100.1 AV			1.47 H	52	91.71	8.43
4	11490.00	58.3 PK	74.0	-15.7	1.31 H	109	39.62	18.65
5	11490.00	44.3 AV	54.0	-9.7	1.31 H	109	25.64	18.65

ANTENNA POLARITY & TEST DISTANCE: VERTICAL AT 3 M

NO.	FREQ. (MHz)	EMISSION LEVEL (dBuV/m)	LIMIT (dBuV/m)	MARGIN (dB)	ANTENNA HEIGHT (m)	TABLE ANGLE (Degree)	RAW VALUE (dBuV)	CORRECTION FACTOR (dB/m)
1	#5649.99	59.6 PK	68.2	-8.6	1.52 V	133	50.98	8.64
2	*5745.00	105.2 PK			1.52 V	133	96.79	8.43
3	*5745.00	101.7 AV			1.52 V	133	93.25	8.43
4	11490.00	57.7 PK	74.0	-16.3	1.08 V	88	39.03	18.65
5	11490.00	43.9 AV	54.0	-10.1	1.08 V	88	25.27	18.65

REMARKS:

- Emission Level(dBuV/m) = Raw Value(dBuV) + Correction Factor(dB/m)
- Correction Factor(dB/m) = Antenna Factor(dB/m) + Cable Factor(dB) – Pre-Amplifier Factor(dB)
- The other emission levels were very low against the limit.
- Margin value = Emission Level – Limit value
- " * ": Fundamental frequency.
- " # ": The radiated frequency is out of the restricted band.

CHANNEL	TX Channel 157	DETECTOR FUNCTION	Peak (PK)
FREQUENCY RANGE	1GHz ~ 40GHz		Average (AV)

ANTENNA POLARITY & TEST DISTANCE: HORIZONTAL AT 3 M								
---	--	--	--	--	--	--	--	--

NO.	FREQ. (MHz)	EMISSION LEVEL (dBuV/m)	LIMIT (dBuV/m)	MARGIN (dB)	ANTENNA HEIGHT (m)	TABLE ANGLE (Degree)	RAW VALUE (dBuV)	CORRECTION FACTOR (dB/m)
1	*5785.00	112.9 PK			1.49 H	56	104.51	8.34
2	*5785.00	100.2 AV			1.49 H	56	91.82	8.34
3	11570.00	58.5 PK	74.0	-15.5	1.24 H	228	39.67	18.81
4	11570.00	44.7 AV	54.0	-9.3	1.24 H	228	25.89	18.81

ANTENNA POLARITY & TEST DISTANCE: VERTICAL AT 3 M								
---	--	--	--	--	--	--	--	--

NO.	FREQ. (MHz)	EMISSION LEVEL (dBuV/m)	LIMIT (dBuV/m)	MARGIN (dB)	ANTENNA HEIGHT (m)	TABLE ANGLE (Degree)	RAW VALUE (dBuV)	CORRECTION FACTOR (dB/m)
1	*5785.00	104.9 PK			1.50 V	136	96.59	8.34
2	*5785.00	101.8 AV			1.50 V	136	93.43	8.34
3	11570.00	57.5 PK	74.0	-16.5	1.10 V	94	38.73	18.81
4	11570.00	44.1 AV	54.0	-9.9	1.10 V	94	25.31	18.81

REMARKS:

1. Emission Level(dBuV/m) = Raw Value(dBuV) + Correction Factor(dB/m)
2. Correction Factor(dB/m) = Antenna Factor(dB/m) + Cable Factor(dB) – Pre-Amplifier Factor(dB)
3. The other emission levels were very low against the limit.
4. Margin value = Emission Level – Limit value
5. " * ": Fundamental frequency.

CHANNEL	TX Channel 165	DETECTOR FUNCTION	Peak (PK)
FREQUENCY RANGE	1GHz ~ 40GHz		Average (AV)

ANTENNA POLARITY & TEST DISTANCE: HORIZONTAL AT 3 M

NO.	FREQ. (MHz)	EMISSION LEVEL (dBuV/m)	LIMIT (dBuV/m)	MARGIN (dB)	ANTENNA HEIGHT (m)	TABLE ANGLE (Degree)	RAW VALUE (dBuV)	CORRECTION FACTOR (dB/m)
1	*5825.00	112.6 PK			1.67 H	53	104.29	8.33
2	*5825.00	100.0 AV			1.67 H	53	91.66	8.33
3	#5925.01	61.5 PK	68.2	-6.7	1.67 H	53	52.98	8.50
4	11650.00	57.8 PK	74.0	-16.2	1.19 H	217	39.24	18.59
5	11650.00	44.1 AV	54.0	-9.9	1.19 H	217	25.51	18.59

ANTENNA POLARITY & TEST DISTANCE: VERTICAL AT 3 M

NO.	FREQ. (MHz)	EMISSION LEVEL (dBuV/m)	LIMIT (dBuV/m)	MARGIN (dB)	ANTENNA HEIGHT (m)	TABLE ANGLE (Degree)	RAW VALUE (dBuV)	CORRECTION FACTOR (dB/m)
1	*5825.00	104.3 PK			1.53 V	127	95.97	8.33
2	*5825.00	101.6 AV			1.53 V	127	93.24	8.33
3	#5925.01	59.6 PK	68.2	-8.7	1.53 V	127	51.05	8.50
4	11650.00	57.3 PK	74.0	-16.7	1.07 V	84	38.71	18.59
5	11650.00	43.9 AV	54.0	-10.1	1.07 V	84	25.30	18.59

REMARKS:

1. Emission Level(dBuV/m) = Raw Value(dBuV) + Correction Factor(dB/m)
2. Correction Factor(dB/m) = Antenna Factor(dB/m) + Cable Factor(dB) – Pre-Amplifier Factor(dB)
3. The other emission levels were very low against the limit.
4. Margin value = Emission Level – Limit value
5. " * ": Fundamental frequency.
6. " # ": The radiated frequency is out of the restricted band.

802.11ac (40MHz)

CHANNEL	TX Channel 38	DETECTOR FUNCTION	Peak (PK)
FREQUENCY RANGE	1GHz ~ 40GHz		Average (AV)

ANTENNA POLARITY & TEST DISTANCE: HORIZONTAL AT 3 M								
NO.	FREQ. (MHz)	EMISSION LEVEL (dBuV/m)	LIMIT (dBuV/m)	MARGIN (dB)	ANTENNA HEIGHT (m)	TABLE ANGLE (Degree)	RAW VALUE (dBuV)	CORRECTION FACTOR (dB/m)
1	5150.00	72.7 PK	74.0	-1.3	1.62 H	98	64.16	8.53
2	5150.00	51.3 AV	54.0	-2.7	1.62 H	98	42.81	8.53
3	*5190.00	110.6 PK			1.62 H	98	101.81	8.77
4	*5190.00	99.9 AV			1.62 H	98	91.17	8.77
5	#10380.00	61.4 PK	74.0	-12.6	2.06 H	306	41.00	20.40
6	#10380.00	48.5 AV	54.0	-5.5	2.06 H	306	28.14	20.40

ANTENNA POLARITY & TEST DISTANCE: VERTICAL AT 3 M								
NO.	FREQ. (MHz)	EMISSION LEVEL (dBuV/m)	LIMIT (dBuV/m)	MARGIN (dB)	ANTENNA HEIGHT (m)	TABLE ANGLE (Degree)	RAW VALUE (dBuV)	CORRECTION FACTOR (dB/m)
1	5150.00	66.0 PK	74.0	-8.0	3.99 V	41	57.49	8.53
2	5150.00	48.5 AV	54.0	-5.5	3.99 V	41	39.98	8.53
3	*5190.00	106.2 PK			3.99 V	41	97.42	8.77
4	*5190.00	95.9 AV			3.99 V	41	87.16	8.77
5	#10380.00	60.6 PK	74.0	-13.4	1.82 V	225	40.17	20.40
6	#10380.00	47.7 AV	54.0	-6.3	1.82 V	225	27.33	20.40

REMARKS:

- Emission Level(dBuV/m) = Raw Value(dBuV) + Correction Factor(dB/m)
- Correction Factor(dB/m) = Antenna Factor(dB/m) + Cable Factor(dB) – Pre-Amplifier Factor(dB)
- The other emission levels were very low against the limit.
- Margin value = Emission Level – Limit value
- " * ": Fundamental frequency.
- " # ": The radiated frequency is out of the restricted band.

CHANNEL	TX Channel 46	DETECTOR FUNCTION	Peak (PK)
FREQUENCY RANGE	1GHz ~ 40GHz		Average (AV)

ANTENNA POLARITY & TEST DISTANCE: HORIZONTAL AT 3 M

NO.	FREQ. (MHz)	EMISSION LEVEL (dBuV/m)	LIMIT (dBuV/m)	MARGIN (dB)	ANTENNA HEIGHT (m)	TABLE ANGLE (Degree)	RAW VALUE (dBuV)	CORRECTION FACTOR (dB/m)
1	*5230.00	110.1 PK			1.88 H	99	101.19	8.94
2	*5230.00	99.5 AV			1.88 H	99	90.54	8.94
3	5350.00	62.3 PK	74.0	-11.7	1.88 H	99	52.85	9.43
4	5350.00	46.9 AV	54.0	-7.1	1.88 H	99	37.50	9.43
5	#10460.00	62.4 PK	74.0	-11.6	1.99 H	268	41.63	20.79
6	#10460.00	49.4 AV	54.0	-4.6	1.99 H	268	28.64	20.79

ANTENNA POLARITY & TEST DISTANCE: VERTICAL AT 3 M

NO.	FREQ. (MHz)	EMISSION LEVEL (dBuV/m)	LIMIT (dBuV/m)	MARGIN (dB)	ANTENNA HEIGHT (m)	TABLE ANGLE (Degree)	RAW VALUE (dBuV)	CORRECTION FACTOR (dB/m)
1	*5230.00	107.2 PK			2.63 V	187	98.26	8.94
2	*5230.00	97.9 AV			2.63 V	187	89.00	8.94
3	5350.00	61.1 PK	74.0	-12.9	2.63 V	187	51.69	9.43
4	5350.00	46.3 AV	54.0	-7.7	2.63 V	187	36.89	9.43
5	#10460.00	61.2 PK	74.0	-12.8	2.95 V	184	40.45	20.79
6	#10460.00	48.5 AV	54.0	-5.6	2.95 V	184	27.66	20.79

REMARKS:

- Emission Level(dBuV/m) = Raw Value(dBuV) + Correction Factor(dB/m)
- Correction Factor(dB/m) = Antenna Factor(dB/m) + Cable Factor(dB) – Pre-Amplifier Factor(dB)
- The other emission levels were very low against the limit.
- Margin value = Emission Level – Limit value
- " * ": Fundamental frequency.
- " # ": The radiated frequency is out of the restricted band.

CHANNEL	TX Channel 151	DETECTOR FUNCTION	Peak (PK)
FREQUENCY RANGE	1GHz ~ 40GHz		Average (AV)

ANTENNA POLARITY & TEST DISTANCE: HORIZONTAL AT 3 M

NO.	FREQ. (MHz)	EMISSION LEVEL (dBuV/m)	LIMIT (dBuV/m)	MARGIN (dB)	ANTENNA HEIGHT (m)	TABLE ANGLE (Degree)	RAW VALUE (dBuV)	CORRECTION FACTOR (dB/m)
1	#5649.99	63.5 PK	68.2	-4.8	1.68 H	53	54.81	8.64
2	*5755.00	109.7 PK			1.68 H	53	101.28	8.41
3	*5755.00	99.1 AV			1.68 H	53	90.67	8.41
4	11510.00	57.5 PK	74.0	-16.5	1.00 H	223	38.93	18.61
5	11510.00	45.4 AV	54.0	-8.6	1.00 H	223	26.77	18.61

ANTENNA POLARITY & TEST DISTANCE: VERTICAL AT 3 M

NO.	FREQ. (MHz)	EMISSION LEVEL (dBuV/m)	LIMIT (dBuV/m)	MARGIN (dB)	ANTENNA HEIGHT (m)	TABLE ANGLE (Degree)	RAW VALUE (dBuV)	CORRECTION FACTOR (dB/m)
1	#5649.99	59.9 PK	68.2	-8.3	1.46 V	125	51.22	8.64
2	*5755.00	102.0 PK			1.46 V	125	93.56	8.41
3	*5755.00	91.4 AV			1.46 V	125	82.94	8.41
4	11510.00	57.0 PK	74.0	-17.0	1.11 V	92	38.40	18.61
5	11510.00	44.0 AV	54.0	-10.0	1.11 V	92	25.42	18.61

REMARKS:

1. Emission Level(dBuV/m) = Raw Value(dBuV) + Correction Factor(dB/m)
2. Correction Factor(dB/m) = Antenna Factor(dB/m) + Cable Factor(dB) – Pre-Amplifier Factor(dB)
3. The other emission levels were very low against the limit.
4. Margin value = Emission Level – Limit value
5. " * ": Fundamental frequency.
6. " # ": The radiated frequency is out of the restricted band.

CHANNEL	TX Channel 159	DETECTOR FUNCTION	Peak (PK)
FREQUENCY RANGE	1GHz ~ 40GHz		Average (AV)

ANTENNA POLARITY & TEST DISTANCE: HORIZONTAL AT 3 M

NO.	FREQ. (MHz)	EMISSION LEVEL (dBuV/m)	LIMIT (dBuV/m)	MARGIN (dB)	ANTENNA HEIGHT (m)	TABLE ANGLE (Degree)	RAW VALUE (dBuV)	CORRECTION FACTOR (dB/m)
1	*5795.00	109.7 PK			1.62 H	55	101.33	8.32
2	*5795.00	98.8 AV			1.62 H	55	90.46	8.32
3	#5925.01	61.1 PK	68.2	-7.1	1.62 H	55	52.59	8.50
4	11590.00	58.0 PK	74.0	-16.0	1.26 H	220	39.13	18.87
5	11590.00	44.7 AV	54.0	-9.3	1.26 H	220	25.84	18.87

ANTENNA POLARITY & TEST DISTANCE: VERTICAL AT 3 M

NO.	FREQ. (MHz)	EMISSION LEVEL (dBuV/m)	LIMIT (dBuV/m)	MARGIN (dB)	ANTENNA HEIGHT (m)	TABLE ANGLE (Degree)	RAW VALUE (dBuV)	CORRECTION FACTOR (dB/m)
1	*5795.00	101.9 PK			1.51 V	130	93.59	8.32
2	*5795.00	91.0 AV			1.51 V	130	82.64	8.32
3	#5925.01	59.1 PK	68.2	-9.1	1.51 V	130	50.62	8.50
4	11590.00	57.4 PK	74.0	-16.6	1.05 V	99	38.53	18.87
5	11590.00	44.2 AV	54.0	-9.8	1.05 V	99	25.37	18.87

REMARKS:

1. Emission Level(dBuV/m) = Raw Value(dBuV) + Correction Factor(dB/m)
2. Correction Factor(dB/m) = Antenna Factor(dB/m) + Cable Factor(dB) – Pre-Amplifier Factor(dB)
3. The other emission levels were very low against the limit.
4. Margin value = Emission Level – Limit value
5. " * ": Fundamental frequency.
6. " # ": The radiated frequency is out of the restricted band.

802.11ac (80MHz)

CHANNEL	TX Channel 42	DETECTOR FUNCTION	Peak (PK)
FREQUENCY RANGE	1GHz ~ 40GHz		Average (AV)

ANTENNA POLARITY & TEST DISTANCE: HORIZONTAL AT 3 M

NO.	FREQ. (MHz)	EMISSION LEVEL (dBuV/m)	LIMIT (dBuV/m)	MARGIN (dB)	ANTENNA HEIGHT (m)	TABLE ANGLE (Degree)	RAW VALUE (dBuV)	CORRECTION FACTOR (dB/m)
1	5150.00	72.8 PK	74.0	-1.2	1.77 H	100	64.26	8.53
2	5150.00	49.7 AV	54.0	-4.3	1.77 H	100	41.14	8.53
3	*5210.00	111.5 PK			1.77 H	100	102.68	8.86
4	*5210.00	99.8 AV			1.77 H	100	90.94	8.86
5	5350.00	61.8 PK	74.0	-12.2	1.77 H	100	52.33	9.43
6	5350.00	46.7 AV	54.0	-7.3	1.77 H	100	37.29	9.43
7	#10420.00	61.8 PK	74.0	-12.2	2.51 H	333	41.23	20.58
8	#10420.00	47.0 AV	54.0	-7.0	2.51 H	333	26.39	20.58

ANTENNA POLARITY & TEST DISTANCE: VERTICAL AT 3 M

NO.	FREQ. (MHz)	EMISSION LEVEL (dBuV/m)	LIMIT (dBuV/m)	MARGIN (dB)	ANTENNA HEIGHT (m)	TABLE ANGLE (Degree)	RAW VALUE (dBuV)	CORRECTION FACTOR (dB/m)
1	5150.00	65.9 PK	74.0	-8.1	3.85 V	155	57.38	8.53
2	5150.00	47.6 AV	54.0	-6.4	3.85 V	155	39.04	8.53
3	*5210.00	100.8 PK			3.85 V	155	91.93	8.86
4	*5210.00	90.8 AV			3.85 V	155	81.91	8.86
5	5350.00	61.1 PK	74.0	-12.9	3.85 V	155	51.68	9.43
6	5350.00	46.1 AV	54.0	-7.9	3.85 V	155	36.69	9.43
7	#10420.00	60.8 PK	74.0	-13.2	1.43 V	264	40.19	20.58
8	#10420.00	46.8 AV	54.0	-7.2	1.43 V	264	26.19	20.58

REMARKS:

1. Emission Level(dBuV/m) = Raw Value(dBuV) + Correction Factor(dB/m)
2. Correction Factor(dB/m) = Antenna Factor(dB/m) + Cable Factor(dB) – Pre-Amplifier Factor(dB)
3. The other emission levels were very low against the limit.
4. Margin value = Emission Level – Limit value
5. " * ": Fundamental frequency.
6. " # ": The radiated frequency is out of the restricted band.

CHANNEL	TX Channel 155	DETECTOR FUNCTION	Peak (PK)
FREQUENCY RANGE	1GHz ~ 40GHz		Average (AV)

ANTENNA POLARITY & TEST DISTANCE: HORIZONTAL AT 3 M

NO.	FREQ. (MHz)	EMISSION LEVEL (dBuV/m)	LIMIT (dBuV/m)	MARGIN (dB)	ANTENNA HEIGHT (m)	TABLE ANGLE (Degree)	RAW VALUE (dBuV)	CORRECTION FACTOR (dB/m)
1	#5649.99	66.3 PK	68.2	-1.9	1.64 H	58	57.68	8.64
2	*5775.00	105.6 PK			1.64 H	58	97.22	8.37
3	*5775.00	95.0 AV			1.64 H	58	86.61	8.37
4	#5925.01	64.4 PK	68.2	-3.8	1.64 H	58	55.91	8.50
5	11550.00	58.1 PK	74.0	-15.9	1.19 H	217	39.34	18.74
6	11550.00	44.7 AV	54.0	-9.3	1.19 H	217	25.96	18.74

ANTENNA POLARITY & TEST DISTANCE: VERTICAL AT 3 M

NO.	FREQ. (MHz)	EMISSION LEVEL (dBuV/m)	LIMIT (dBuV/m)	MARGIN (dB)	ANTENNA HEIGHT (m)	TABLE ANGLE (Degree)	RAW VALUE (dBuV)	CORRECTION FACTOR (dB/m)
1	#5649.99	62.3 PK	68.2	-6.0	1.50 V	135	53.61	8.64
2	*5775.00	97.5 PK			1.50 V	135	89.12	8.37
3	*5775.00	88.4 AV			1.50 V	135	80.06	8.37
4	#5925.01	61.4 PK	68.2	-6.8	1.50 V	135	52.86	8.50
5	11550.00	57.4 PK	74.0	-16.6	1.04 V	96	38.62	18.74
6	11550.00	44.3 AV	54.0	-9.8	1.04 V	96	25.51	18.74

REMARKS:

- Emission Level(dBuV/m) = Raw Value(dBuV) + Correction Factor(dB/m)
- Correction Factor(dB/m) = Antenna Factor(dB/m) + Cable Factor(dB) – Pre-Amplifier Factor(dB)
- The other emission levels were very low against the limit.
- Margin value = Emission Level – Limit value
- " * ": Fundamental frequency.
- " # ": The radiated frequency is out of the restricted band.

Beamforming Mode

802.11ac (20MHz)

CHANNEL	TX Channel 36	DETECTOR FUNCTION	Peak (PK)
FREQUENCY RANGE	1GHz ~ 40GHz		Average (AV)

ANTENNA POLARITY & TEST DISTANCE: HORIZONTAL AT 3 M

NO.	FREQ. (MHz)	EMISSION LEVEL (dBuV/m)	LIMIT (dBuV/m)	MARGIN (dB)	ANTENNA HEIGHT (m)	TABLE ANGLE (Degree)	RAW VALUE (dBuV)	CORRECTION FACTOR (dB/m)
1	5150.00	69.7 PK	74.0	-4.3	1.63 H	139	62.81	6.85
2	5150.00	52.9 AV	54.0	-1.1	1.63 H	139	46.05	6.85
3	*5180.00	109.3 PK			1.63 H	139	102.33	6.95
4	*5180.00	97.2 AV			1.63 H	139	90.25	6.95
5	#10360.00	58.1 PK	74.0	-15.9	3.21 H	280	40.97	17.14
6	#10360.00	44.8 AV	54.0	-9.2	3.21 H	280	27.64	17.14

ANTENNA POLARITY & TEST DISTANCE: VERTICAL AT 3 M

NO.	FREQ. (MHz)	EMISSION LEVEL (dBuV/m)	LIMIT (dBuV/m)	MARGIN (dB)	ANTENNA HEIGHT (m)	TABLE ANGLE (Degree)	RAW VALUE (dBuV)	CORRECTION FACTOR (dB/m)
1	5150.00	63.8 PK	74.0	-10.2	4.00 V	211	56.99	6.85
2	5150.00	48.6 AV	54.0	-5.4	4.00 V	211	41.77	6.85
3	*5180.00	106.2 PK			4.00 V	211	99.23	6.95
4	*5180.00	95.1 AV			4.00 V	211	88.13	6.95
5	#10360.00	57.2 PK	74.0	-16.8	1.59 V	65	40.06	17.14
6	#10360.00	42.8 AV	54.0	-11.2	1.59 V	65	25.64	17.14

REMARKS:

- Emission Level(dBuV/m) = Raw Value(dBuV) + Correction Factor(dB/m)
- Correction Factor(dB/m) = Antenna Factor(dB/m) + Cable Factor(dB) – Pre-Amplifier Factor(dB)
- The other emission levels were very low against the limit.
- Margin value = Emission Level – Limit value
- " * ": Fundamental frequency.
- " # ": The radiated frequency is out of the restricted band.

CHANNEL	TX Channel 40	DETECTOR FUNCTION	Peak (PK)
FREQUENCY RANGE	1GHz ~ 40GHz		Average (AV)

ANTENNA POLARITY & TEST DISTANCE: HORIZONTAL AT 3 M								
---	--	--	--	--	--	--	--	--

NO.	FREQ. (MHz)	EMISSION LEVEL (dBuV/m)	LIMIT (dBuV/m)	MARGIN (dB)	ANTENNA HEIGHT (m)	TABLE ANGLE (Degree)	RAW VALUE (dBuV)	CORRECTION FACTOR (dB/m)
1	*5200.00	114.5 PK			1.53 H	278	107.44	7.01
2	*5200.00	100.9 AV			1.53 H	278	93.85	7.01
3	#10400.00	58.8 PK	74.0	-15.2	1.86 H	113	41.36	17.44
4	#10400.00	45.4 AV	54.0	-8.6	1.86 H	113	27.96	17.44

ANTENNA POLARITY & TEST DISTANCE: VERTICAL AT 3 M								
---	--	--	--	--	--	--	--	--

NO.	FREQ. (MHz)	EMISSION LEVEL (dBuV/m)	LIMIT (dBuV/m)	MARGIN (dB)	ANTENNA HEIGHT (m)	TABLE ANGLE (Degree)	RAW VALUE (dBuV)	CORRECTION FACTOR (dB/m)
1	*5200.00	103.9 PK			1.89 V	209	96.86	7.01
2	*5200.00	93.4 AV			1.89 V	209	86.35	7.01
3	#10400.00	57.1 PK	74.0	-16.9	1.74 V	23	39.68	17.44
4	#10400.00	44.0 AV	54.0	-10.0	1.74 V	23	26.52	17.44

REMARKS:

1. Emission Level(dBuV/m) = Raw Value(dBuV) + Correction Factor(dB/m)
2. Correction Factor(dB/m) = Antenna Factor(dB/m) + Cable Factor(dB) – Pre-Amplifier Factor(dB)
3. The other emission levels were very low against the limit.
4. Margin value = Emission Level – Limit value
5. " * ": Fundamental frequency.
6. " # ": The radiated frequency is out of the restricted band.

CHANNEL	TX Channel 48	DETECTOR FUNCTION	Peak (PK)
FREQUENCY RANGE	1GHz ~ 40GHz		Average (AV)

ANTENNA POLARITY & TEST DISTANCE: HORIZONTAL AT 3 M								
---	--	--	--	--	--	--	--	--

NO.	FREQ. (MHz)	EMISSION LEVEL (dBuV/m)	LIMIT (dBuV/m)	MARGIN (dB)	ANTENNA HEIGHT (m)	TABLE ANGLE (Degree)	RAW VALUE (dBuV)	CORRECTION FACTOR (dB/m)
1	*5240.00	115.9 PK			1.97 H	145	108.73	7.16
2	*5240.00	104.3 AV			1.97 H	145	97.14	7.16
3	5350.00	58.3 PK	74.0	-15.7	1.97 H	145	50.68	7.64
4	5350.00	45.2 AV	54.0	-8.8	1.97 H	145	37.56	7.64
5	#10480.00	58.0 PK	74.0	-16.0	1.66 H	251	40.16	17.87
6	#10480.00	44.8 AV	54.0	-9.2	1.66 H	251	26.89	17.87

ANTENNA POLARITY & TEST DISTANCE: VERTICAL AT 3 M								
---	--	--	--	--	--	--	--	--

NO.	FREQ. (MHz)	EMISSION LEVEL (dBuV/m)	LIMIT (dBuV/m)	MARGIN (dB)	ANTENNA HEIGHT (m)	TABLE ANGLE (Degree)	RAW VALUE (dBuV)	CORRECTION FACTOR (dB/m)
1	*5240.00	106.8 PK			2.13 V	165	99.63	7.16
2	*5240.00	93.6 AV			2.13 V	165	86.39	7.16
3	5350.00	52.4 PK	74.0	-21.6	2.13 V	165	44.76	7.64
4	5350.00	38.2 AV	54.0	-15.8	2.13 V	165	30.55	7.64
5	#10480.00	57.1 PK	74.0	-16.9	2.26 V	103	39.21	17.87
6	#10480.00	43.0 AV	54.0	-11.0	2.26 V	103	25.16	17.87

REMARKS:

1. Emission Level(dBuV/m) = Raw Value(dBuV) + Correction Factor(dB/m)
2. Correction Factor(dB/m) = Antenna Factor(dB/m) + Cable Factor(dB) – Pre-Amplifier Factor(dB)
3. The other emission levels were very low against the limit.
4. Margin value = Emission Level – Limit value
5. " * ": Fundamental frequency.
6. " # ": The radiated frequency is out of the restricted band.

CHANNEL	TX Channel 149	DETECTOR FUNCTION	Peak (PK)
FREQUENCY RANGE	1GHz ~ 40GHz		Average (AV)

ANTENNA POLARITY & TEST DISTANCE: HORIZONTAL AT 3 M

NO.	FREQ. (MHz)	EMISSION LEVEL (dBuV/m)	LIMIT (dBuV/m)	MARGIN (dB)	ANTENNA HEIGHT (m)	TABLE ANGLE (Degree)	RAW VALUE (dBuV)	CORRECTION FACTOR (dB/m)
1	#5649.99	61.9 PK	68.2	-6.3	1.53 H	8	53.25	8.64
2	*5745.00	114.0 PK			1.53 H	8	105.58	8.43
3	*5745.00	102.5 AV			1.53 H	8	94.11	8.43
4	11490.00	57.4 PK	74.0	-16.6	2.33 H	263	38.78	18.65
5	11490.00	42.4 AV	54.0	-11.7	2.33 H	263	23.70	18.65

ANTENNA POLARITY & TEST DISTANCE: VERTICAL AT 3 M

NO.	FREQ. (MHz)	EMISSION LEVEL (dBuV/m)	LIMIT (dBuV/m)	MARGIN (dB)	ANTENNA HEIGHT (m)	TABLE ANGLE (Degree)	RAW VALUE (dBuV)	CORRECTION FACTOR (dB/m)
1	#5649.99	61.1 PK	68.2	-7.1	3.83 V	118	52.47	8.64
2	*5745.00	106.1 PK			3.83 V	118	97.63	8.43
3	*5745.00	95.5 AV			3.83 V	118	87.10	8.43
4	11490.00	56.1 PK	74.0	-17.9	1.34 V	233	37.49	18.65
5	11490.00	41.2 AV	54.0	-12.8	1.34 V	233	22.59	18.65

REMARKS:

1. Emission Level(dBuV/m) = Raw Value(dBuV) + Correction Factor(dB/m)
2. Correction Factor(dB/m) = Antenna Factor(dB/m) + Cable Factor(dB) – Pre-Amplifier Factor(dB)
3. The other emission levels were very low against the limit.
4. Margin value = Emission Level – Limit value
5. " * ": Fundamental frequency.
6. " # ": The radiated frequency is out of the restricted band.

CHANNEL	TX Channel 157	DETECTOR FUNCTION	Peak (PK)
FREQUENCY RANGE	1GHz ~ 40GHz		Average (AV)

ANTENNA POLARITY & TEST DISTANCE: HORIZONTAL AT 3 M								
---	--	--	--	--	--	--	--	--

NO.	FREQ. (MHz)	EMISSION LEVEL (dBuV/m)	LIMIT (dBuV/m)	MARGIN (dB)	ANTENNA HEIGHT (m)	TABLE ANGLE (Degree)	RAW VALUE (dBuV)	CORRECTION FACTOR (dB/m)
1	*5785.00	112.1 PK			2.32 H	21	103.75	8.34
2	*5785.00	100.2 AV			2.32 H	21	91.89	8.34
3	11570.00	58.7 PK	74.0	-15.3	1.94 H	48	39.87	18.81
4	11570.00	44.0 AV	54.0	-10.0	1.94 H	48	25.21	18.81

ANTENNA POLARITY & TEST DISTANCE: VERTICAL AT 3 M								
---	--	--	--	--	--	--	--	--

NO.	FREQ. (MHz)	EMISSION LEVEL (dBuV/m)	LIMIT (dBuV/m)	MARGIN (dB)	ANTENNA HEIGHT (m)	TABLE ANGLE (Degree)	RAW VALUE (dBuV)	CORRECTION FACTOR (dB/m)
1	*5785.00	100.5 PK			2.30 V	41	92.19	8.34
2	*5785.00	89.2 AV			2.30 V	41	80.89	8.34
3	11570.00	56.8 PK	74.0	-17.3	1.43 V	97	37.94	18.81
4	11570.00	42.9 AV	54.0	-11.1	1.43 V	97	24.09	18.81

REMARKS:

1. Emission Level(dBuV/m) = Raw Value(dBuV) + Correction Factor(dB/m)
2. Correction Factor(dB/m) = Antenna Factor(dB/m) + Cable Factor(dB) – Pre-Amplifier Factor(dB)
3. The other emission levels were very low against the limit.
4. Margin value = Emission Level – Limit value
5. " * ": Fundamental frequency.

CHANNEL	TX Channel 165	DETECTOR FUNCTION	Peak (PK)
FREQUENCY RANGE	1GHz ~ 40GHz		Average (AV)

ANTENNA POLARITY & TEST DISTANCE: HORIZONTAL AT 3 M

NO.	FREQ. (MHz)	EMISSION LEVEL (dBuV/m)	LIMIT (dBuV/m)	MARGIN (dB)	ANTENNA HEIGHT (m)	TABLE ANGLE (Degree)	RAW VALUE (dBuV)	CORRECTION FACTOR (dB/m)
1	*5825.00	111.4 PK			3.37 H	232	103.07	8.33
2	*5825.00	99.8 AV			3.37 H	232	91.44	8.33
3	#5925.01	61.3 PK	68.2	-6.9	3.37 H	232	52.80	8.50
4	11650.00	58.8 PK	74.0	-15.2	2.01 H	94	40.19	18.59
5	11650.00	43.8 AV	54.0	-10.2	2.01 H	94	25.19	18.59

ANTENNA POLARITY & TEST DISTANCE: VERTICAL AT 3 M

NO.	FREQ. (MHz)	EMISSION LEVEL (dBuV/m)	LIMIT (dBuV/m)	MARGIN (dB)	ANTENNA HEIGHT (m)	TABLE ANGLE (Degree)	RAW VALUE (dBuV)	CORRECTION FACTOR (dB/m)
1	*5825.00	101.3 PK			1.46 V	200	93.01	8.33
2	*5825.00	88.7 AV			1.46 V	200	80.36	8.33
3	#5925.01	59.5 PK	68.2	-8.7	1.46 V	200	51.03	8.50
4	11650.00	58.5 PK	74.0	-15.5	1.99 V	55	39.87	18.59
5	11650.00	43.2 AV	54.0	-10.8	1.99 V	55	24.63	18.59

REMARKS:

1. Emission Level(dBuV/m) = Raw Value(dBuV) + Correction Factor(dB/m)
2. Correction Factor(dB/m) = Antenna Factor(dB/m) + Cable Factor(dB) – Pre-Amplifier Factor(dB)
3. The other emission levels were very low against the limit.
4. Margin value = Emission Level – Limit value
5. " * ": Fundamental frequency.
6. " # ": The radiated frequency is out of the restricted band.

802.11ac (40MHz)

CHANNEL	TX Channel 38	DETECTOR FUNCTION	Peak (PK)
FREQUENCY RANGE	1GHz ~ 40GHz		Average (AV)

ANTENNA POLARITY & TEST DISTANCE: HORIZONTAL AT 3 M								
NO.	FREQ. (MHz)	EMISSION LEVEL (dBuV/m)	LIMIT (dBuV/m)	MARGIN (dB)	ANTENNA HEIGHT (m)	TABLE ANGLE (Degree)	RAW VALUE (dBuV)	CORRECTION FACTOR (dB/m)
1	5150.00	66.5 PK	74.0	-7.5	3.99 H	137	59.69	6.85
2	5150.00	52.8 AV	54.0	-1.2	3.99 H	137	45.97	6.85
3	*5190.00	101.7 PK			3.99 H	137	94.75	6.99
4	*5190.00	91.4 AV			3.99 H	137	84.38	6.99
5	#10380.00	58.6 PK	74.0	-15.5	1.64 H	214	41.26	17.29
6	#10380.00	44.9 AV	54.0	-9.1	1.64 H	214	27.64	17.29

ANTENNA POLARITY & TEST DISTANCE: VERTICAL AT 3 M								
NO.	FREQ. (MHz)	EMISSION LEVEL (dBuV/m)	LIMIT (dBuV/m)	MARGIN (dB)	ANTENNA HEIGHT (m)	TABLE ANGLE (Degree)	RAW VALUE (dBuV)	CORRECTION FACTOR (dB/m)
1	5150.00	58.2 PK	74.0	-15.8	1.69 V	261	51.36	6.85
2	5150.00	46.7 AV	54.0	-7.3	1.69 V	261	39.89	6.85
3	*5190.00	90.6 PK			1.69 V	261	83.65	6.99
4	*5190.00	84.6 AV			1.69 V	261	77.65	6.99
5	#10380.00	57.9 PK	74.0	-16.1	1.99 V	43	40.65	17.29
6	#10380.00	43.6 AV	54.0	-10.4	1.99 V	43	26.35	17.29

REMARKS:

- Emission Level(dBuV/m) = Raw Value(dBuV) + Correction Factor(dB/m)
- Correction Factor(dB/m) = Antenna Factor(dB/m) + Cable Factor(dB) – Pre-Amplifier Factor(dB)
- The other emission levels were very low against the limit.
- Margin value = Emission Level – Limit value
- " * ": Fundamental frequency.
- " # ": The radiated frequency is out of the restricted band.

CHANNEL	TX Channel 46	DETECTOR FUNCTION	Peak (PK)
FREQUENCY RANGE	1GHz ~ 40GHz		Average (AV)

ANTENNA POLARITY & TEST DISTANCE: HORIZONTAL AT 3 M

NO.	FREQ. (MHz)	EMISSION LEVEL (dBuV/m)	LIMIT (dBuV/m)	MARGIN (dB)	ANTENNA HEIGHT (m)	TABLE ANGLE (Degree)	RAW VALUE (dBuV)	CORRECTION FACTOR (dB/m)
1	*5230.00	112.1 PK			1.47 H	137	104.96	7.13
2	*5230.00	99.4 AV			1.47 H	137	92.30	7.13
3	5350.00	60.0 PK	74.0	-14.0	1.47 H	137	52.33	7.64
4	5350.00	46.3 AV	54.0	-7.7	1.47 H	137	38.64	7.64
5	#10460.00	58.2 PK	74.0	-15.8	2.64 H	102	40.40	17.77
6	#10460.00	45.7 AV	54.0	-8.3	2.64 H	102	27.89	17.77

ANTENNA POLARITY & TEST DISTANCE: VERTICAL AT 3 M

NO.	FREQ. (MHz)	EMISSION LEVEL (dBuV/m)	LIMIT (dBuV/m)	MARGIN (dB)	ANTENNA HEIGHT (m)	TABLE ANGLE (Degree)	RAW VALUE (dBuV)	CORRECTION FACTOR (dB/m)
1	*5230.00	99.8 PK			1.84 V	64	92.63	7.13
2	*5230.00	90.8 AV			1.84 V	64	83.65	7.13
3	5350.00	54.6 PK	74.0	-19.4	1.84 V	64	46.96	7.64
4	5350.00	38.0 AV	54.0	-16.0	1.84 V	64	30.36	7.64
5	#10460.00	57.2 PK	74.0	-16.8	1.39 V	214	39.39	17.77
6	#10460.00	44.2 AV	54.0	-9.8	1.39 V	214	26.46	17.77

REMARKS:

- Emission Level(dBuV/m) = Raw Value(dBuV) + Correction Factor(dB/m)
- Correction Factor(dB/m) = Antenna Factor(dB/m) + Cable Factor(dB) – Pre-Amplifier Factor(dB)
- The other emission levels were very low against the limit.
- Margin value = Emission Level – Limit value
- " * ": Fundamental frequency.
- " # ": The radiated frequency is out of the restricted band.

CHANNEL	TX Channel 151	DETECTOR FUNCTION	Peak (PK)
FREQUENCY RANGE	1GHz ~ 40GHz		Average (AV)

ANTENNA POLARITY & TEST DISTANCE: HORIZONTAL AT 3 M

NO.	FREQ. (MHz)	EMISSION LEVEL (dBuV/m)	LIMIT (dBuV/m)	MARGIN (dB)	ANTENNA HEIGHT (m)	TABLE ANGLE (Degree)	RAW VALUE (dBuV)	CORRECTION FACTOR (dB/m)
1	#5649.99	62.2 PK	68.2	-6.0	1.73 H	339	53.59	8.64
2	*5755.00	112.2 PK			1.73 H	339	103.74	8.41
3	*5755.00	100.3 AV			1.73 H	339	91.89	8.41
4	11510.00	59.7 PK	74.0	-14.3	2.69 H	98	41.06	18.61
5	11510.00	46.3 AV	54.0	-7.8	2.69 H	98	27.64	18.61

ANTENNA POLARITY & TEST DISTANCE: VERTICAL AT 3 M

NO.	FREQ. (MHz)	EMISSION LEVEL (dBuV/m)	LIMIT (dBuV/m)	MARGIN (dB)	ANTENNA HEIGHT (m)	TABLE ANGLE (Degree)	RAW VALUE (dBuV)	CORRECTION FACTOR (dB/m)
1	#5649.99	60.8 PK	68.2	-7.4	2.31 V	164	52.15	8.64
2	*5755.00	100.5 PK			2.31 V	164	92.05	8.41
3	*5755.00	89.4 AV			2.31 V	164	80.96	8.41
4	11510.00	58.9 PK	74.0	-15.1	1.18 V	250	40.33	18.61
5	11510.00	44.7 AV	54.0	-9.3	1.18 V	250	26.13	18.61

REMARKS:

1. Emission Level(dBuV/m) = Raw Value(dBuV) + Correction Factor(dB/m)
2. Correction Factor(dB/m) = Antenna Factor(dB/m) + Cable Factor(dB) – Pre-Amplifier Factor(dB)
3. The other emission levels were very low against the limit.
4. Margin value = Emission Level – Limit value
5. " * ": Fundamental frequency.
6. " # ": The radiated frequency is out of the restricted band.

CHANNEL	TX Channel 159	DETECTOR FUNCTION	Peak (PK)
FREQUENCY RANGE	1GHz ~ 40GHz		Average (AV)

ANTENNA POLARITY & TEST DISTANCE: HORIZONTAL AT 3 M

NO.	FREQ. (MHz)	EMISSION LEVEL (dBuV/m)	LIMIT (dBuV/m)	MARGIN (dB)	ANTENNA HEIGHT (m)	TABLE ANGLE (Degree)	RAW VALUE (dBuV)	CORRECTION FACTOR (dB/m)
1	*5795.00	109.5 PK			1.41 H	240	101.14	8.32
2	*5795.00	97.7 AV			1.41 H	240	89.33	8.32
3	#5925.01	61.8 PK	68.2	-6.5	1.41 H	240	53.25	8.50
4	11590.00	59.1 PK	74.0	-14.9	2.09 H	325	40.19	18.87
5	11590.00	45.8 AV	54.0	-8.2	2.09 H	325	26.89	18.87

ANTENNA POLARITY & TEST DISTANCE: VERTICAL AT 3 M

NO.	FREQ. (MHz)	EMISSION LEVEL (dBuV/m)	LIMIT (dBuV/m)	MARGIN (dB)	ANTENNA HEIGHT (m)	TABLE ANGLE (Degree)	RAW VALUE (dBuV)	CORRECTION FACTOR (dB/m)
1	*5795.00	98.5 PK			1.69 V	208	90.22	8.32
2	*5795.00	87.0 AV			1.69 V	208	78.66	8.32
3	#5925.01	60.6 PK	68.2	-7.6	1.69 V	208	52.11	8.50
4	11590.00	58.5 PK	74.0	-15.5	1.82 V	20	39.63	18.87
5	11590.00	44.4 AV	54.0	-9.7	1.82 V	20	25.48	18.87

REMARKS:

1. Emission Level(dBuV/m) = Raw Value(dBuV) + Correction Factor(dB/m)
2. Correction Factor(dB/m) = Antenna Factor(dB/m) + Cable Factor(dB) – Pre-Amplifier Factor(dB)
3. The other emission levels were very low against the limit.
4. Margin value = Emission Level – Limit value
5. " * ": Fundamental frequency.
6. " # ": The radiated frequency is out of the restricted band.

802.11ac (80MHz)

CHANNEL	TX Channel 42	DETECTOR FUNCTION	Peak (PK)
FREQUENCY RANGE	1GHz ~ 40GHz		Average (AV)

ANTENNA POLARITY & TEST DISTANCE: HORIZONTAL AT 3 M

NO.	FREQ. (MHz)	EMISSION LEVEL (dBuV/m)	LIMIT (dBuV/m)	MARGIN (dB)	ANTENNA HEIGHT (m)	TABLE ANGLE (Degree)	RAW VALUE (dBuV)	CORRECTION FACTOR (dB/m)
1	5150.00	72.9 PK	74.0	-1.1	1.84 H	15	66.07	6.85
2	5150.00	51.6 AV	54.0	-2.4	1.84 H	15	44.73	6.85
3	*5210.00	103.1 PK			1.84 H	15	96.05	7.05
4	*5210.00	89.4 AV			1.84 H	15	82.30	7.05
5	5350.00	59.6 PK	74.0	-14.4	1.84 H	360	52.00	7.64
6	5350.00	44.9 AV	54.0	-9.1	1.84 H	15	37.23	7.64
7	#10420.00	58.5 PK	74.0	-15.5	1.99 H	52	40.96	17.55
8	#10420.00	45.5 AV	54.0	-8.5	1.99 H	52	27.96	17.55

ANTENNA POLARITY & TEST DISTANCE: VERTICAL AT 3 M

NO.	FREQ. (MHz)	EMISSION LEVEL (dBuV/m)	LIMIT (dBuV/m)	MARGIN (dB)	ANTENNA HEIGHT (m)	TABLE ANGLE (Degree)	RAW VALUE (dBuV)	CORRECTION FACTOR (dB/m)
1	5150.00	61.2 PK	74.0	-12.8	1.97 V	46	54.31	6.85
2	5150.00	43.1 AV	54.0	-10.9	1.97 V	46	36.29	6.85
3	*5210.00	94.7 PK			1.97 V	46	87.64	7.05
4	*5210.00	78.4 AV			1.97 V	46	71.36	7.05
5	5350.00	50.3 PK	74.0	-23.7	1.97 V	46	42.63	7.64
6	5350.00	43.5 AV	54.0	-10.5	1.97 V	46	35.85	7.64
7	#10420.00	57.1 PK	74.0	-16.9	2.16 V	36	39.54	17.55
8	#10420.00	43.4 AV	54.0	-10.6	2.16 V	36	25.84	17.55

REMARKS:

- Emission Level(dBuV/m) = Raw Value(dBuV) + Correction Factor(dB/m)
- Correction Factor(dB/m) = Antenna Factor(dB/m) + Cable Factor(dB) – Pre-Amplifier Factor(dB)
- The other emission levels were very low against the limit.
- Margin value = Emission Level – Limit value
- " * ": Fundamental frequency.
- " # ": The radiated frequency is out of the restricted band.

CHANNEL	TX Channel 155	DETECTOR FUNCTION	Peak (PK)
FREQUENCY RANGE	1GHz ~ 40GHz		Average (AV)

ANTENNA POLARITY & TEST DISTANCE: HORIZONTAL AT 3 M

NO.	FREQ. (MHz)	EMISSION LEVEL (dBuV/m)	LIMIT (dBuV/m)	MARGIN (dB)	ANTENNA HEIGHT (m)	TABLE ANGLE (Degree)	RAW VALUE (dBuV)	CORRECTION FACTOR (dB/m)
1	#5649.99	65.4 PK	68.2	-2.8	1.78 H	48	56.76	8.64
2	*5775.00	109.0 PK			1.78 H	48	100.63	8.37
3	*5775.00	95.3 AV			1.78 H	48	86.95	8.37
4	#5925.01	65.2 PK	68.2	-3.0	1.78 H	48	56.67	8.50
5	11550.00	58.9 PK	74.0	-15.1	1.97 H	208	40.19	18.74
6	11550.00	45.7 AV	54.0	-8.3	1.97 H	208	26.98	18.74

ANTENNA POLARITY & TEST DISTANCE: VERTICAL AT 3 M

NO.	FREQ. (MHz)	EMISSION LEVEL (dBuV/m)	LIMIT (dBuV/m)	MARGIN (dB)	ANTENNA HEIGHT (m)	TABLE ANGLE (Degree)	RAW VALUE (dBuV)	CORRECTION FACTOR (dB/m)
1	#5649.99	64.6 PK	68.2	-3.6	2.14 V	60	55.97	8.64
2	*5775.00	98.1 PK			2.14 V	60	89.68	8.37
3	*5775.00	85.3 AV			2.14 V	60	76.96	8.37
4	#5925.01	64.5 PK	68.2	-3.7	2.14 V	60	55.98	8.50
5	11550.00	57.9 PK	74.0	-16.1	1.63 V	44	39.15	18.74
6	11550.00	44.1 AV	54.0	-9.9	1.63 V	44	25.35	18.74

REMARKS:

- Emission Level(dBuV/m) = Raw Value(dBuV) + Correction Factor(dB/m)
- Correction Factor(dB/m) = Antenna Factor(dB/m) + Cable Factor(dB) – Pre-Amplifier Factor(dB)
- The other emission levels were very low against the limit.
- Margin value = Emission Level – Limit value
- " * ": Fundamental frequency.
- " # ": The radiated frequency is out of the restricted band.

BELOW 1GHz WORST-CASE DATA

802.11ac (40MHz)

CHANNEL	TX Channel 46	DETECTOR FUNCTION	Quasi-Peak (QP)
FREQUENCY RANGE	30MHz ~ 1GHz		

ANTENNA POLARITY & TEST DISTANCE: HORIZONTAL AT 3 M

NO.	FREQ. (MHz)	EMISSION LEVEL (dBuV/m)	LIMIT (dBuV/m)	MARGIN (dB)	ANTENNA HEIGHT (m)	TABLE ANGLE (Degree)	RAW VALUE (dBuV)	CORRECTION FACTOR (dB/m)
1	30.53	24.4 QP	40.0	-15.6	4.00 H	232	35.90	-11.47
2	159.93	25.3 QP	43.5	-18.2	4.00 H	152	34.68	-9.37
3	408.40	34.5 QP	46.0	-11.6	3.24 H	204	39.93	-5.48
4	509.08	35.9 QP	46.0	-10.1	2.09 H	97	39.15	-3.26
5	799.31	36.3 QP	46.0	-9.7	1.02 H	97	34.77	1.56
6	972.89	33.9 QP	54.0	-20.1	1.00 H	349	29.02	4.87

ANTENNA POLARITY & TEST DISTANCE: VERTICAL AT 3 M

NO.	FREQ. (MHz)	EMISSION LEVEL (dBuV/m)	LIMIT (dBuV/m)	MARGIN (dB)	ANTENNA HEIGHT (m)	TABLE ANGLE (Degree)	RAW VALUE (dBuV)	CORRECTION FACTOR (dB/m)
1	35.29	33.9 QP	40.0	-6.1	1.21 V	79	44.90	-11.03
2	82.38	28.2 QP	40.0	-11.8	1.00 V	315	42.72	-14.48
3	136.89	27.1 QP	43.5	-16.4	1.00 V	125	37.35	-10.29
4	370.81	37.8 QP	46.0	-8.2	2.20 V	301	44.13	-6.30
5	606.57	32.4 QP	46.0	-13.6	2.91 V	144	33.82	-1.43
6	799.31	34.5 QP	46.0	-11.6	3.08 V	216	32.89	1.56

REMARKS:

1. Emission Level(dBuV/m) = Raw Value(dBuV) + Correction Factor(dB/m)
2. Correction Factor(dB/m) = Antenna Factor(dB/m) + Cable Factor(dB) – Pre-Amplifier Factor(dB)
3. The other emission levels were very low against the limit.
4. Margin value = Emission Level – Limit value

4.2 Conducted Emission Measurement

4.2.1 Limits of Conducted Emission Measurement

Frequency (MHz)	Conducted Limit (dBuV)	
	Quasi-peak	Average
0.15 - 0.5	66 - 56	56 - 46
0.50 - 5.0	56	46
5.0 - 30.0	60	50

Note: 1. The lower limit shall apply at the transition frequencies.

2. The limit decreases in line with the logarithm of the frequency in the range of 0.15 to 0.50MHz.

4.2.2 Test Instruments

Description & Manufacturer	Model No.	Serial No.	Cal. Date	Cal. Due
ROHDE & SCHWARZ TEST RECEIVER	ESCS 30	100276	Apr. 12, 2016	Apr. 11, 2017
ROHDE & SCHWARZ Artificial Mains Network (for EUT)	ENV216	101197	Apr. 27, 2015	Apr. 26, 2016
LISN With Adapter (for EUT)	AD10	C10Ada-002	Apr. 27, 2015	Apr. 26, 2016
ROHDE & SCHWARZ Artificial Mains Network (for peripherals)	ESH3-Z5	100218	Nov. 25, 2015	Nov. 24, 2016
SCHWARZBECK Artificial Mains Network (For EUT)	NNLK8129	8129229	May 06, 2015	May 05, 2016
Software	Cond_V7.3.7	NA	NA	NA
RF cable (JYEBAO) With 10dB PAD	5D-FB	Cable-C10.01	Feb. 15, 2016	Feb. 14, 2017
SUHNER Terminator (For ROHDE & SCHWARZ LISN)	65BNC-5001	E1-011484	May 19, 2015	May 18, 2016
ROHDE & SCHWARZ Artificial Mains Network (For TV EUT)	ESH3-Z5	100220	Nov. 13, 2015	Nov. 12, 2016
LISN With Adapter (for TV EUT)	100220	N/A	Nov. 13, 2015	Nov. 12, 2016

Notes: 1. The calibration interval of the above test instruments is 12 months and the calibrations are traceable to NML/ROC and NIST/USA.

2. The test was performed in Shielded Room No. 10.

3. The VCCI Site Registration No. C-1852.

4. Tested Date: Apr. 19, 2016.

4.2.3 Test Procedure

- The EUT was placed 0.4 meters from the conducting wall of the shielded room with EUT being connected to the power mains through a line impedance stabilization network (LISN). Other support units were connected to the power mains through another LISN. The two LISNs provide 50 ohm/ 50uH of coupling impedance for the measuring instrument.
- Both lines of the power mains connected to the EUT were checked for maximum conducted interference.
- The frequency range from 150kHz to 30MHz was searched. Emission levels under (Limit - 20dB) was not recorded.

NOTE: All modes of operation were investigated and the worst-case emissions are reported.

4.2.4 Deviation from Test Standard

No deviation.

4.2.5 Test Setup

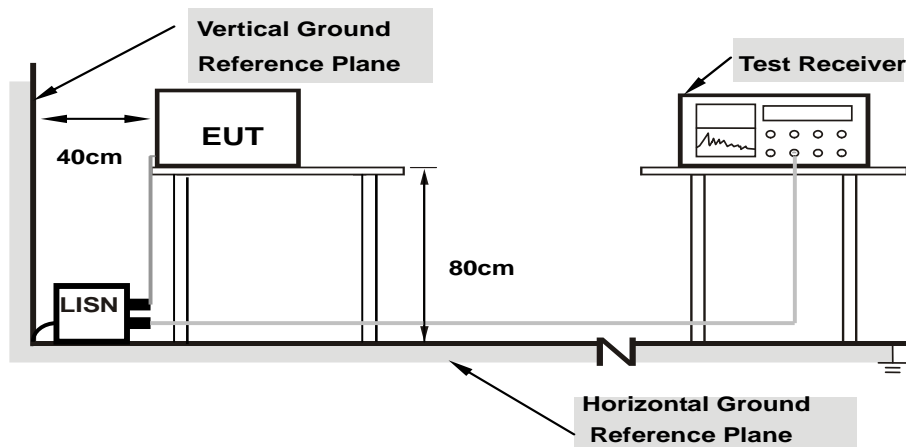

- Note:**
- Support units were connected to second LISN.
 - Both of LISNs (AMN) are 80 cm from EUT and at least 80 from other units and other metal planes

For the actual test configuration, please refer to the attached file (Test Setup Photo).

4.2.6 EUT Operating Condition

Same as 4.1.6.

4.2.7 Test Results

CDD Mode

802.11ac (40MHz)

Phase	Line (L)	Detector Function	Quasi-Peak (QP) / Average (AV)
-------	----------	-------------------	--------------------------------

No	Frequency (MHz)	Correction Factor (dB)	Reading Value (dBuV)		Emission Level (dBuV)		Limit (dBuV)		Margin (dB)	
			Q.P.	AV.	Q.P.	AV.	Q.P.	AV.	Q.P.	AV.
1	0.15000	9.66	38.54	24.84	48.20	34.50	66.00	56.00	-17.80	-21.50
2	0.17734	9.65	33.40	16.46	43.05	26.11	64.61	54.61	-21.55	-28.49
3	0.29453	9.66	19.47	2.41	29.13	12.07	60.40	50.40	-31.26	-38.32
4	0.52891	9.70	21.92	15.07	31.62	24.77	56.00	46.00	-24.38	-21.23
5	8.30078	10.07	33.68	25.69	43.75	35.76	60.00	50.00	-16.25	-14.24
6	10.86328	10.12	33.94	26.68	44.06	36.80	60.00	50.00	-15.94	-13.20
7	18.49219	10.29	28.04	20.51	38.33	30.80	60.00	50.00	-21.67	-19.20

Remarks:

1. Q.P. and AV. are abbreviations of quasi-peak and average individually.
2. The emission levels of other frequencies were very low against the limit.
3. Margin value = Emission level – Limit value
4. Correction factor = Insertion loss + Cable loss
5. Emission Level = Correction Factor + Reading Value

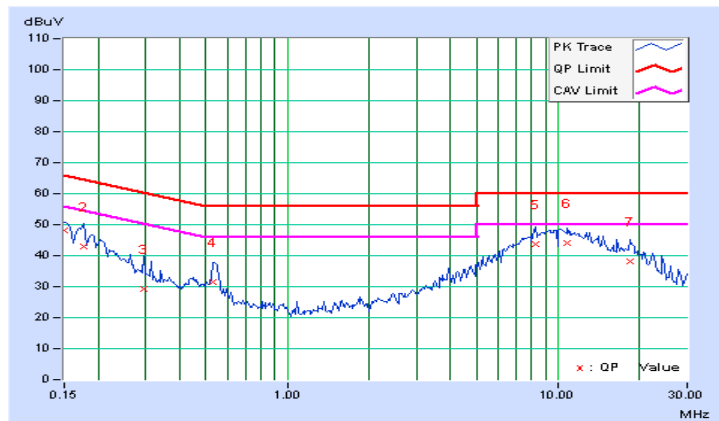

Phase	Neutral (N)	Detector Function	Quasi-Peak (QP) / Average (AV)
-------	-------------	-------------------	--------------------------------

No	Frequency (MHz)	Correction Factor (dB)	Reading Value (dBuV)		Emission Level (dBuV)		Limit (dBuV)		Margin (dB)	
			Q.P.	AV.	Q.P.	AV.	Q.P.	AV.	Q.P.	AV.
1	0.16953	9.69	35.62	19.35	45.31	29.04	64.98	54.98	-19.67	-25.94
2	0.21641	9.69	26.25	8.73	35.94	18.42	62.96	52.96	-27.01	-34.53
3	0.54063	9.74	25.62	21.03	35.36	30.77	56.00	46.00	-20.64	-15.23
4	2.77344	9.98	15.42	9.67	25.40	19.65	56.00	46.00	-30.60	-26.35
5	4.40625	10.12	20.64	12.27	30.76	22.39	56.00	46.00	-25.24	-23.61
6	10.27344	10.21	30.09	23.18	40.30	33.39	60.00	50.00	-19.70	-16.61
7	19.44531	10.36	22.84	15.44	33.20	25.80	60.00	50.00	-26.80	-24.20

Remarks:

1. Q.P. and AV. are abbreviations of quasi-peak and average individually.
2. The emission levels of other frequencies were very low against the limit.
3. Margin value = Emission level – Limit value
4. Correction factor = Insertion loss + Cable loss
5. Emission Level = Correction Factor + Reading Value

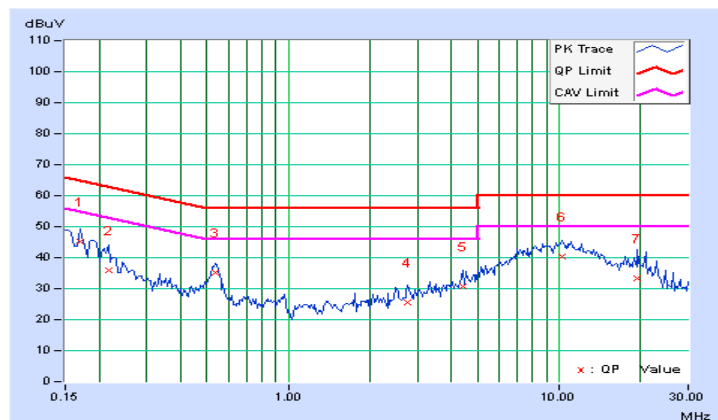

4.3 Transmit Power Measurement

4.3.1 Limits of Transmit Power Measurement

Operation Band	EUT Category		Limit
U-NII-1		Outdoor Access Point	1 Watt (30 dBm) (Max. e.i.r.p \leq 125mW(21 dBm) at any elevation angle above 30 degrees as measured from the horizon)
		Fixed point-to-point Access Point	1 Watt (30 dBm)
	√	Indoor Access Point	1 Watt (30 dBm)
		Mobile and Portable client device	250mW (24 dBm)
U-NII-2A	---		250mW (24 dBm) or 11 dBm+10 log B*
U-NII-2C	---		250mW (24 dBm) or 11 dBm+10 log B*
U-NII-3	√		1 Watt (30 dBm)

*B is the 26 dB emission bandwidth in megahertz

Per KDB 662911 Method of conducted output power measurement on IEEE 802.11 devices,

Array Gain = 0 dB (i.e., no array gain) for $N_{ANT} \leq 4$;

Array Gain = 0 dB (i.e., no array gain) for channel widths ≥ 40 MHz for any N_{ANT} ;

Array Gain = $5 \log(N_{ANT}/N_{SS})$ dB or 3 dB, whichever is less for 20-MHz channel widths with $N_{ANT} \geq 5$.

For power measurements on all other devices: Array Gain = $10 \log(N_{ANT}/N_{SS})$ dB.

4.3.2 Test Setup

FOR POWER OUTPUT MEASUREMENT

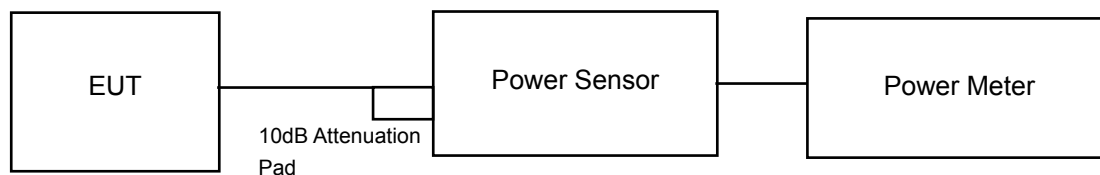

FOR 26dB & OCCUPIED BANDWIDTH

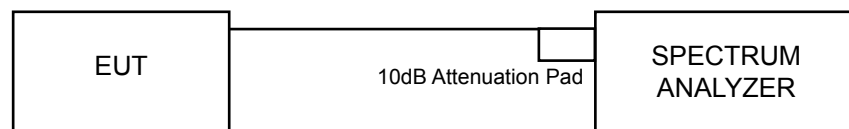

4.3.3 Test Instruments

Refer to section 4.1.2 to get information of above instrument.

4.3.4 Test Procedure

For Average Power Measurement

For 802.11a, 802.11ac (20MHz), 802.11ac (40MHz)

Method PM is used to perform output power measurement, trigger and gating function of wide band power meter is enabled to measure max output power of TX on burst. Duty factor is not added to measured value.

For 802.11ac (80MHz)

- 1) Set span to encompass the entire 26 dB EBW (or, alternatively, the entire 99% occupied bandwidth) of the signal.
- 2) Set sweep trigger to "free run".
- 3) Set RBW = 1 MHz.
- 4) Set VBW \geq 3 MHz
- 5) Number of points in sweep \geq 2 Span / RBW.
- 6) Sweep time \leq (number of points in sweep) * T
- 7) Using emission bandwidth to determine the frequency span for integration the channel bandwidth.
- 8) Detector = RMS.
- 9) Trace mode = max hold.
- 10) Allow max hold to run for at least 60 seconds, or longer as needed to allow the trace to stabilize.

FOR 26 BANDWIDTH

- 1) Set RBW = approximately 1% of the emission bandwidth.
- 2) Set the VBW > RBW.
- 3) Detector = Peak.
- 4) Trace mode = max hold.
- 5) Measure the maximum width of the emission that is 26 dB down from the peak of the emission. Compare this with the RBW setting of the analyzer. Readjust RBW and repeat measurement as needed until the RBW/EBW ratio is approximately 1%.

For Occupied Bandwidth

The transmitter output was connected to the spectrum analyzer through an attenuator. The bandwidth of the fundamental frequency was measured by spectrum analyzer with resolution bandwidth in the range of 1% to 5% of the anticipated emission bandwidth, and a video bandwidth at least 3x the resolution bandwidth and set the detector to AVERAGE. The width of a frequency band such that, below the lower and above the upper frequency limits, the mean powers emitted are each equal to a specified percentage 0.5 %of the total mean power of a given emission.

4.3.5 Deviation from Test Standard

No deviation.

4.3.6 EUT Operating Condition

The software provided by client to enable the EUT under transmission condition continuously at lowest, middle and highest channel frequencies individually.

4.3.7 Test Result

CDD Mode

Power Output:

802.11a

Chan.	Chan. Freq. (MHz)	Maximum Conducted Power (dBm)				Total Power (mW)	Total Power (dBm)	Power Limit (dBm)	Pass/Fail
		Chain 0	Chain 1	Chain 2	Chain 3				
36	5180	19.96	19.71	20.24	20.37	407.199	26.10	30	Pass
40	5200	20.15	19.96	20.45	20.64	429.392	26.33	30	Pass
48	5240	20.18	19.72	20.29	20.45	415.810	26.19	30	Pass
149	5745	19.85	19.43	20.23	19.57	380.317	25.80	30	Pass
157	5785	19.79	20.65	19.74	20.13	408.653	26.11	30	Pass
165	5825	19.64	20.63	19.37	20.31	401.552	26.04	30	Pass

802.11ac (20MHz)

Chan.	Chan. Freq. (MHz)	Maximum Conducted Power (dBm)				Total Power (mW)	Total Power (dBm)	Power Limit (dBm)	Pass/Fail
		Chain 0	Chain 1	Chain 2	Chain 3				
36	5180	19.66	19.50	20.04	20.42	392.674	25.94	30	Pass
40	5200	19.65	19.37	19.88	20.27	382.443	25.83	30	Pass
48	5240	19.76	19.32	19.69	20.23	378.681	25.78	30	Pass
149	5745	19.05	18.34	19.36	18.42	304.387	24.83	30	Pass
157	5785	19.24	20.11	19.24	19.74	364.646	25.62	30	Pass
165	5825	19.04	20.10	18.99	19.91	359.696	25.56	30	Pass

802.11ac (40MHz)

Chan.	Chan. Freq. (MHz)	Maximum Conducted Power (dBm)				Total Power (mW)	Total Power (dBm)	Power Limit (dBm)	Pass/Fail
		Chain 0	Chain 1	Chain 2	Chain 3				
38	5190	17.29	16.88	17.44	17.84	218.610	23.40	30	Pass
46	5230	20.68	19.99	20.59	21.02	457.745	26.61	30	Pass
151	5755	20.64	19.73	20.87	20.19	436.502	26.40	30	Pass
159	5795	20.61	19.78	20.94	20.16	438.058	26.42	30	Pass

802.11ac (80MHz)

Chan.	Chan. Freq. (MHz)	Maximum Conducted Power (dBm)				Total Power (mW)	Total Power (dBm)	Power Limit (dBm)	Pass/Fail
		Chain 0	Chain 1	Chain 2	Chain 3				
42	5210	16.10	15.64	15.78	16.57	160.620	22.06	30	Pass
155	5775	19.38	20.02	19.18	19.74	364.141	25.61	30	Pass

Beamforming Mode

Power Output:

802.11ac (20MHz)

Chan.	Chan. Freq. (MHz)	Maximum Conducted Power (dBm)				Total Power (mW)	Total Power (dBm)	Power Limit (dBm)	Pass/Fail
		Chain 0	Chain 1	Chain 2	Chain 3				
36	5180	19.54	19.46	19.98	20.27	384.213	25.85	30	Pass
40	5200	19.52	19.31	19.75	19.96	368.335	25.66	30	Pass
48	5240	19.70	19.32	19.49	19.98	367.293	25.65	30	Pass
149	5745	18.96	18.25	19.27	18.33	298.144	24.74	30	Pass
157	5785	19.19	20.06	19.14	19.68	359.308	25.55	30	Pass
165	5825	18.92	20.01	18.90	19.94	354.467	25.50	30	Pass

802.11ac (40MHz)

Chan.	Chan. Freq. (MHz)	Maximum Conducted Power (dBm)				Total Power (mW)	Total Power (dBm)	Power Limit (dBm)	Pass/Fail
		Chain 0	Chain 1	Chain 2	Chain 3				
38	5190	17.27	16.75	17.40	17.63	213.545	23.29	30	Pass
46	5230	20.48	20.06	20.34	20.69	438.440	26.42	30	Pass
151	5755	20.38	19.64	20.79	20.11	423.704	26.27	30	Pass
159	5795	20.53	19.72	20.81	20.07	428.865	26.32	30	Pass

802.11ac (80MHz)

Chan.	Chan. Freq. (MHz)	Maximum Conducted Power (dBm)				Total Power (mW)	Total Power (dBm)	Power Limit (dBm)	Pass/Fail
		Chain 0	Chain 1	Chain 2	Chain 3				
42	5210	16.04	15.59	15.62	16.41	156.630	21.95	30	Pass
155	5775	19.31	19.94	19.15	19.66	358.632	25.55	30	Pass

CDD Mode

26dB Bandwidth:

802.11a

Channel	Channel Frequency (MHz)	26dBc Bandwidth (MHz)				Pass/Fail
		Chain 0	Chain 1	Chain 2	Chain 3	
36	5180	35.72	35.71	35.89	35.95	Pass
40	5200	41.40	41.67	41.65	41.36	Pass
48	5240	35.85	35.68	35.58	35.56	Pass

802.11ac (20MHz)

Channel	Channel Frequency (MHz)	26dBc Bandwidth (MHz)				Pass/Fail
		Chain 0	Chain 1	Chain 2	Chain 3	
36	5180	39.26	39.54	39.42	39.18	Pass
40	5200	39.47	39.24	39.12	39.25	Pass
48	5240	34.37	35.30	36.41	36.18	Pass

802.11ac (40MHz)

Channel	Channel Frequency (MHz)	26dBc Bandwidth (MHz)				Pass/Fail
		Chain 0	Chain 1	Chain 2	Chain 3	
38	5190	66.72	67.37	61.83	61.48	Pass
46	5230	86.98	80.91	80.97	80.68	Pass

802.11ac (80MHz)

Channel	Channel Frequency (MHz)	26dBc Bandwidth (MHz)				Pass/Fail
		Chain 0	Chain 1	Chain 2	Chain 3	
42	5210	110.97	111.26	107.86	105.20	Pass

Spectrum Plot of Worst Value

802.11a

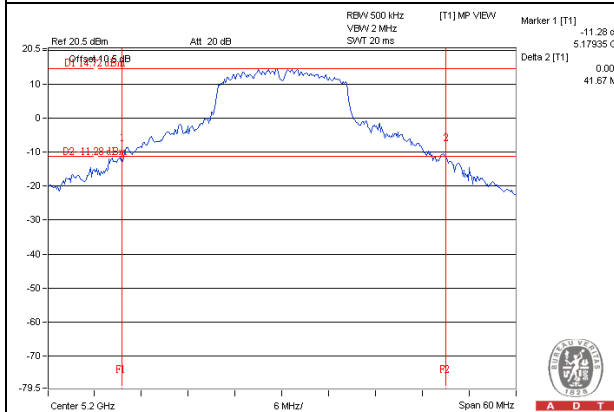

802.11ac (20MHz)

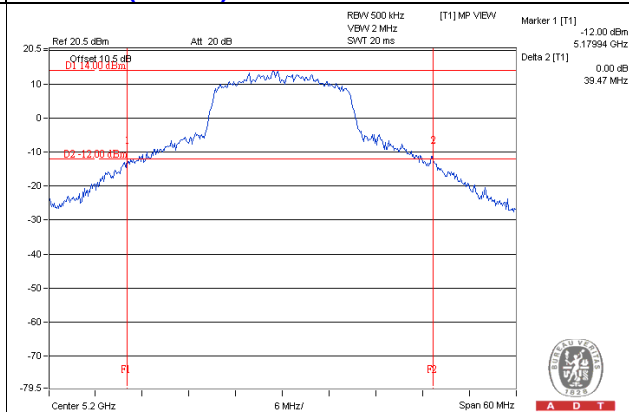

802.11ac (40MHz)

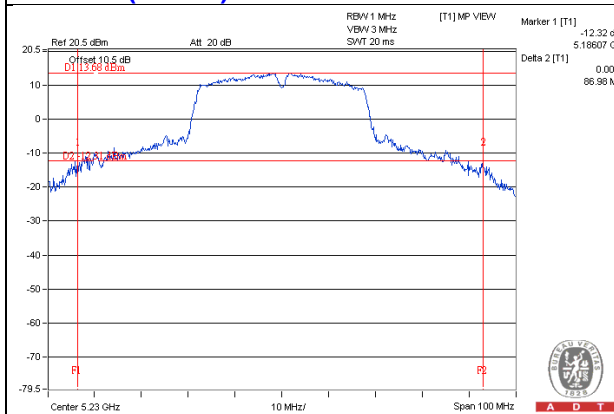

802.11ac (80MHz)

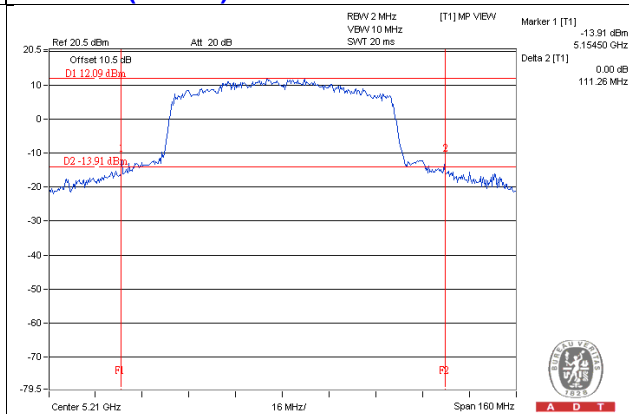

CDD Mode
Occupied Bandwidth:
802.11a

CHANNEL	CHANNEL FREQUENCY (MHz)	OCCUPIED BANDWIDTH (MHz)				PASS / FAIL
		CHAIN 0	CHAIN 1	CHAIN 2	CHAIN 3	
36	5180	19.80	20.76	20.16	20.16	PASS
40	5200	26.16	26.40	26.64	26.52	PASS
48	5240	19.82	19.91	19.91	19.82	PASS
149	5745	22.43	22.40	22.80	22.40	PASS
157	5785	20.70	19.74	21.50	20.96	PASS
165	5825	19.20	19.10	19.70	19.50	PASS

802.11ac (20MHz)

CHANNEL	CHANNEL FREQUENCY (MHz)	OCCUPIED BANDWIDTH (MHz)				PASS / FAIL
		CHAIN 0	CHAIN 1	CHAIN 2	CHAIN 3	
36	5180	21.12	21.72	21.48	21.48	PASS
40	5200	21.96	21.36	21.72	21.84	PASS
48	5240	19.04	18.86	19.39	18.95	PASS
149	5745	20.78	21.40	18.80	18.90	PASS
157	5785	22.20	22.60	21.70	21.40	PASS
165	5825	18.30	19.30	18.20	18.20	PASS

802.11ac (40MHz)

CHANNEL	CHANNEL FREQUENCY (MHz)	OCCUPIED BANDWIDTH (MHz)				PASS / FAIL
		CHAIN 0	CHAIN 1	CHAIN 2	CHAIN 3	
38	5190	36.60	36.60	36.60	36.60	PASS
46	5230	39.86	39.57	39.85	39.56	PASS
151	5755	50.14	41.67	42.50	43.17	PASS
159	5795	41.33	41.00	42.00	40.87	PASS

802.11ac (80MHz)

CHANNEL	CHANNEL FREQUENCY (MHz)	OCCUPIED BANDWIDTH (MHz)				PASS / FAIL
		CHAIN 0	CHAIN 1	CHAIN 2	CHAIN 3	
42	5210	75.60	75.60	75.60	75.60	PASS
155	5775	77.91	77.56	78.12	77.84	PASS

SPECTRUM PLOT OF WORST VALUE

802.11a

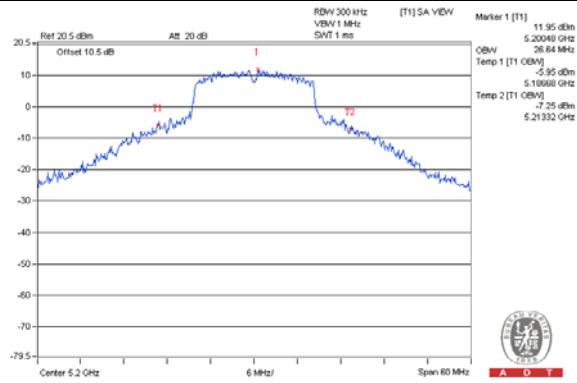

802.11ac (20MHz)

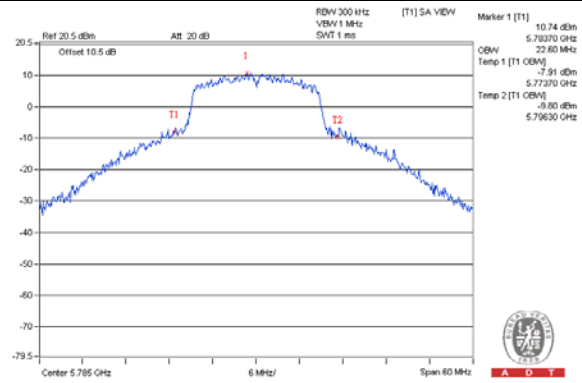

802.11ac (40MHz)

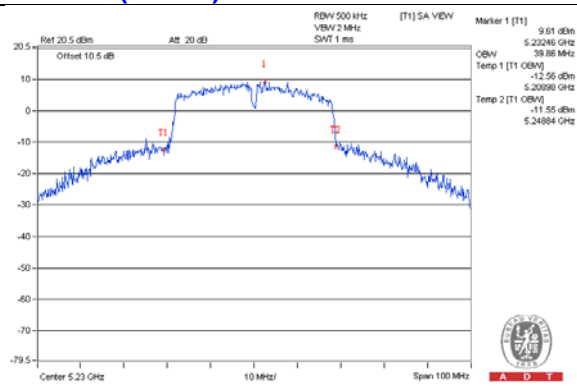

802.11ac (80MHz)

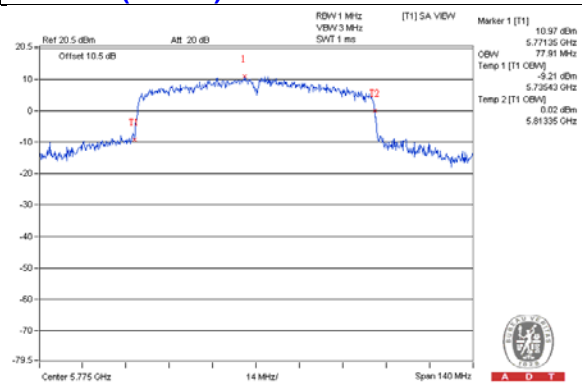

4.4 Peak Power Spectral Density Measurement

4.4.1 Limits of Peak Power Spectral Density Measurement

Operation Band	EUT Category		Limit
U-NII-1		Outdoor Access Point	17dBm/ MHz
		Fixed point-to-point Access Point	
	√	Indoor Access Point	
		Mobile and Portable client device	
U-NII-2A	---		11dBm/ MHz
U-NII-2C	---		11dBm/ MHz
U-NII-3	√		30dBm/ 500kHz

4.4.2 Test Setup

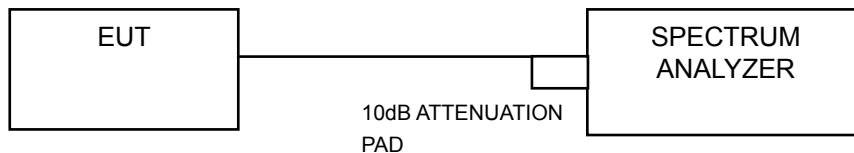

4.4.3 Test Instruments

Refer to section 4.1.2 to get information of above instrument.

4.4.4 Test Procedure

For U-NII-1 band:

Using method SA-2

- 1) Set span to encompass the entire emission bandwidth (EBW) of the signal.
- 2) Set RBW = 1 MHz, Set VBW ≥ 3 MHz, Detector = RMS
- 3) Sweep time = auto, trigger set to “free run”.
- 4) Trace average at least 100 traces in power averaging mode.
- 5) Record the max value and add 10 log (1/duty cycle)

For U-NII-3 band:

- 1) Set span to encompass the entire emission bandwidth (EBW) of the signal.
- 2) Set RBW = 500 kHz, Set VBW ≥ 3 RBW, Detector = RMS
- 3) Sweep time = auto, trigger set to “free run”.
- 4) Trace average at least 100 traces in power averaging mode.
- 5) Record the max value and add 10 log (1/duty cycle)

4.4.5 Deviation from Test Standard

No deviation.

4.4.6 EUT Operating Condition

Same as Item 4.3.6.

4.4.7 Test Results

CDD Mode For U-NII-1 band 802.11a

Chan.	Chan. Freq. (MHz)	PSD (dBm)				Total PSD W/O Duty Factor (dBm)	Duty Factor	Total PSD WITH Duty Factor (dBm)	MAX. Limit (dBm)	Pass / Fail
		Chain 0	Chain 1	Chain 2	Chain 3					
36	5180	5.87	4.92	5.01	6.39	11.61	0.94	12.55	13.98	Pass
40	5200	6.22	6.36	6.57	6.18	12.36	0.94	13.30	13.98	Pass
48	5240	5.13	6.23	5.94	5.07	11.64	0.94	12.58	13.98	Pass

NOTE:

- Method 1 of power density measurement of KDB 662911 is using for calculating total power density. Total power density is summing entire spectra across corresponding frequency bins on the various outputs by computer.
- Directional gain = $3\text{dBi} + 10\log(4) = 9.02\text{dBi} > 6\text{dBi}$, so the power density limit shall be reduced to $17 - (9.02 - 6) = 13.98\text{dBm}$.
- Refer to section 3.3 for duty cycle spectrum plot.

802.11ac (20MHz)

Chan.	Chan. Freq. (MHz)	PSD (dBm)				Total PSD W/O Duty Factor (dBm)	Duty Factor	Total PSD WITH Duty Factor (dBm)	MAX. Limit (dBm)	Pass / Fail
		Chain 0	Chain 1	Chain 2	Chain 3					
36	5180	2.35	3.64	2.52	3.47	9.05	2.72	11.77	13.98	Pass
40	5200	-0.23	0.32	4.74	0.82	7.93	2.72	10.65	13.98	Pass
48	5240	0.87	-0.12	-1.19	-1.34	5.67	2.72	8.39	13.98	Pass

NOTE:

- Method 1 of power density measurement of KDB 662911 is using for calculating total power density. Total power density is summing entire spectra across corresponding frequency bins on the various outputs by computer.
- Directional gain = $3\text{dBi} + 10\log(4) = 9.02\text{dBi} > 6\text{dBi}$, so the power density limit shall be reduced to $17 - (9.02 - 6) = 13.98\text{dBm}$.
- Refer to section 3.3 for duty cycle spectrum plot.

802.11ac (40MHz)

Chan.	Chan. Freq. (MHz)	PSD (dBm)				Total PSD W/O Duty Factor (dBm)	Duty Factor	Total PSD WITH Duty Factor (dBm)	MAX. Limit (dBm)	Pass / Fail
		Chain 0	Chain 1	Chain 2	Chain 3					
38	5190	-7.12	-7.32	-7.44	-6.25	-0.98	4.22	3.24	13.98	Pass
46	5230	-6.44	-4.68	-4.21	-4.73	1.09	4.22	5.31	13.98	Pass

NOTE:

1. Method 1 of power density measurement of KDB 662911 is using for calculating total power density. Total power density is summing entire spectra across corresponding frequency bins on the various outputs by computer.
2. Directional gain = $3\text{dBi} + 10\log(4) = 9.02\text{dBi} > 6\text{dBi}$, so the power density limit shall be reduced to $17-(9.02-6) = 13.98\text{dBm}$.
3. Refer to section 3.3 for duty cycle spectrum plot.

802.11ac (80MHz)

Chan.	Chan. Freq. (MHz)	PSD (dBm)				Total PSD W/O Duty Factor (dBm)	Duty Factor	Total PSD With Duty Factor (dBm)	MAX. Limit (dBm)	Pass / Fail
		Chain 0	Chain 1	Chain 2	Chain 3					
42	5210	-13.52	-11.15	-12.71	-13.11	-6.52	7.18	0.66	13.98	Pass

NOTE:

1. Method 1 of power density measurement of KDB 662911 is using for calculating total power density. Total power density is summing entire spectra across corresponding frequency bins on the various outputs by computer.
2. Directional gain = $3\text{dBi} + 10\log(4) = 9.02\text{dBi} > 6\text{dBi}$, so the power density limit shall be reduced to $17-(9.02-6) = 13.98\text{dBm}$.
3. Refer to section 3.3 for duty cycle spectrum plot.

Spectrum Plot of Worst Value

802.11a

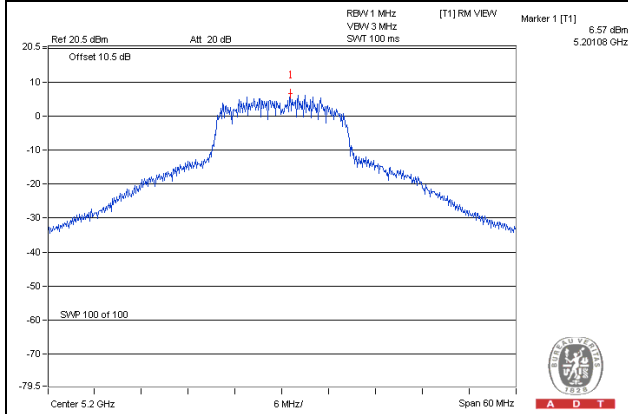

802.11ac (20MHz)

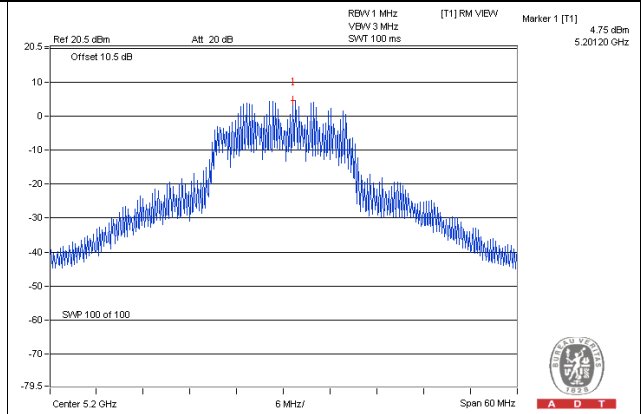

802.11ac (40MHz)

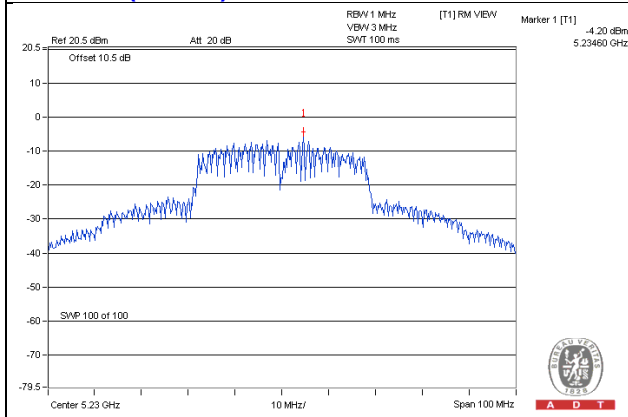

802.11ac (80MHz)

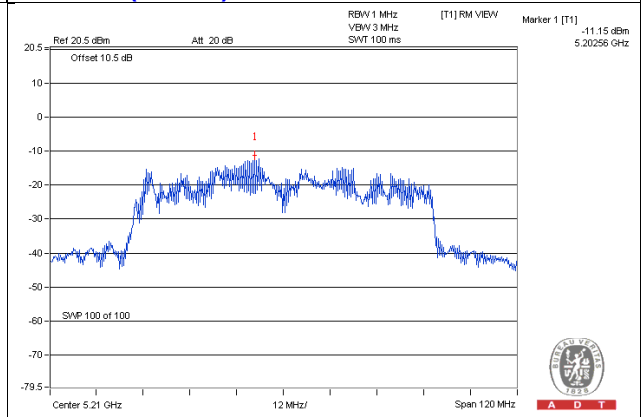

For U-NII-3 Band 802.11a

TX chain	Channel	Freq. (MHz)	PSD (dBm/500kHz)	10 log (N=4) dB	Duty Factor	Total PSD (dBm/500kHz)	Limit (dBm/500kHz)	Pass /Fail
0	149	5745	14.20	6.02	0.94	21.16	26.98	Pass
	157	5785	13.71	6.02	0.94	20.67	26.98	Pass
	165	5825	13.74	6.02	0.94	20.70	26.98	Pass
1	149	5745	14.06	6.02	0.94	21.02	26.98	Pass
	157	5785	13.60	6.02	0.94	20.56	26.98	Pass
	165	5825	13.73	6.02	0.94	20.69	26.98	Pass
2	149	5745	14.32	6.02	0.94	21.28	26.98	Pass
	157	5785	14.16	6.02	0.94	21.12	26.98	Pass
	165	5825	13.24	6.02	0.94	20.20	26.98	Pass
3	149	5745	13.74	6.02	0.94	20.70	26.98	Pass
	157	5785	13.64	6.02	0.94	20.60	26.98	Pass
	165	5825	13.56	6.02	0.94	20.52	26.98	Pass

NOTE:

1. Directional gain = $3\text{dBi} + 10\log(4) = 9.02\text{dBi} > 6\text{dBi}$, so the power density limit shall be reduced to $30 - (9.02 - 6) = 26.98\text{dBm}$.
2. Refer to section 3.3 for duty cycle spectrum plot.

802.11ac (20MHz)

TX chain	Channel	Freq. (MHz)	PSD (dBm/500kHz)	10 log (N=4) dB	Duty Factor	Total PSD (dBm/500kHz)	Limit (dBm/500kHz)	Pass /Fail
0	149	5745	14.43	6.02	2.72	23.17	26.98	Pass
	157	5785	14.25	6.02	2.72	22.99	26.98	Pass
	165	5825	12.89	6.02	2.72	21.63	26.98	Pass
1	149	5745	14.22	6.02	2.72	22.96	26.98	Pass
	157	5785	14.23	6.02	2.72	22.97	26.98	Pass
	165	5825	13.62	6.02	2.72	22.36	26.98	Pass
2	149	5745	13.45	6.02	2.72	22.19	26.98	Pass
	157	5785	14.24	6.02	2.72	22.98	26.98	Pass
	165	5825	12.90	6.02	2.72	21.64	26.98	Pass
3	149	5745	13.45	6.02	2.72	22.19	26.98	Pass
	157	5785	14.18	6.02	2.72	22.92	26.98	Pass
	165	5825	12.94	6.02	2.72	21.68	26.98	Pass

NOTE:

1. Directional gain = $3\text{dBi} + 10\log(4) = 9.02\text{dBi} > 6\text{dBi}$, so the power density limit shall be reduced to $30 - (9.02 - 6) = 26.98\text{dBm}$.
2. Refer to section 3.3 for duty cycle spectrum plot.

802.11ac (40MHz)

TX chain	Channel	Freq. (MHz)	PSD (dBm/500kHz)	10 log (N=4) dB	Duty Factor	Total PSD (dBm/500kHz)	Limit (dBm/500kHz)	Pass /Fail
0	151	5755	12.13	6.02	4.22	22.37	26.98	Pass
	159	5795	12.04	6.02	4.22	22.28	26.98	Pass
1	151	5755	12.13	6.02	4.22	22.37	26.98	Pass
	159	5795	12.15	6.02	4.22	22.39	26.98	Pass
2	151	5755	12.12	6.02	4.22	22.36	26.98	Pass
	159	5795	12.26	6.02	4.22	22.50	26.98	Pass
3	151	5755	12.24	6.02	4.22	22.48	26.98	Pass
	159	5795	11.81	6.02	4.22	22.05	26.98	Pass

NOTE:

1. Directional gain = $3\text{dBi} + 10\log(4) = 9.02\text{dBi} > 6\text{dBi}$, so the power density limit shall be reduced to $30 - (9.02 - 6) = 26.98\text{dBm}$.
2. Refer to section 3.3 for duty cycle spectrum plot.

802.11ac (80MHz)

TX chain	Channel	Freq. (MHz)	PSD (dBm/500kHz)	10 log (N=4) dB	Duty Factor	Total PSD (dBm/500kHz)	Limit (dBm/500kHz)	Pass /Fail
0	155	5775	8.46	6.02	7.18	21.66	26.98	Pass
1	155	5775	8.64	6.02	7.18	21.84	26.98	Pass
2	155	5775	8.69	6.02	7.18	21.89	26.98	Pass
3	155	5775	8.37	6.02	7.18	21.57	26.98	Pass

NOTE:

1. Directional gain = $3\text{dBi} + 10\log(4) = 9.02\text{dBi} > 6\text{dBi}$, so the power density limit shall be reduced to $30 - (9.02 - 6) = 26.98\text{dBm}$.
2. Refer to section 3.3 for duty cycle spectrum plot.

Spectrum Plot of Worst Value

802.11a

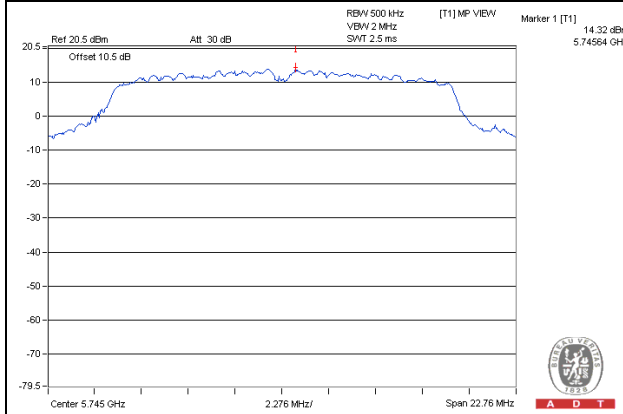

802.11ac (20MHz)

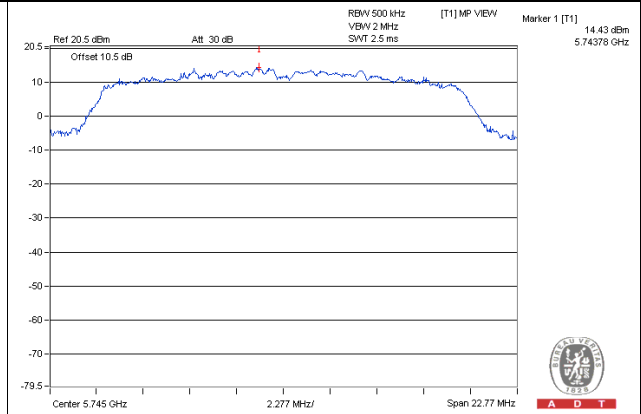

802.11ac (40MHz)

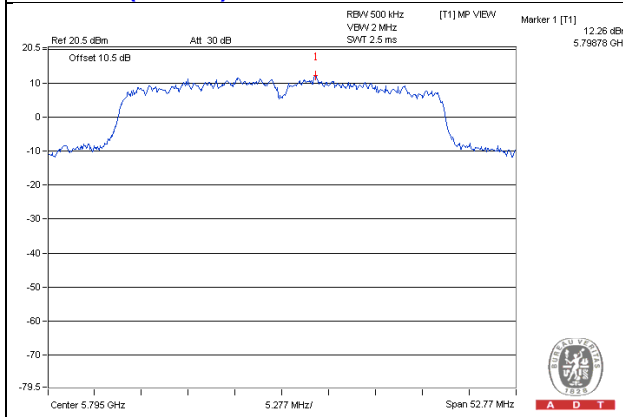

802.11ac (80MHz)

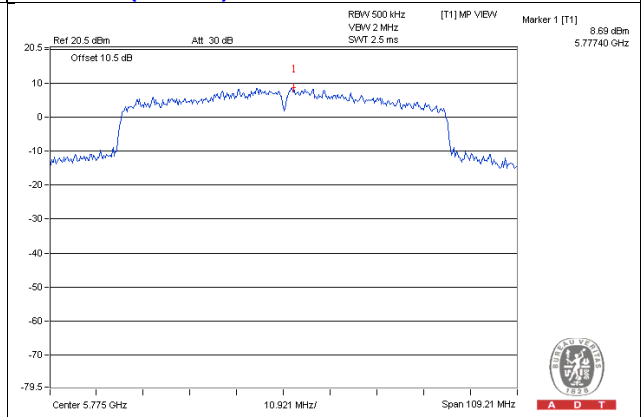

4.5 Frequency Stability Measurement

4.5.1 Limits of Frequency Stability Measurement

The frequency of the carrier signal shall be maintained within band of operation

4.5.2 Test Setup

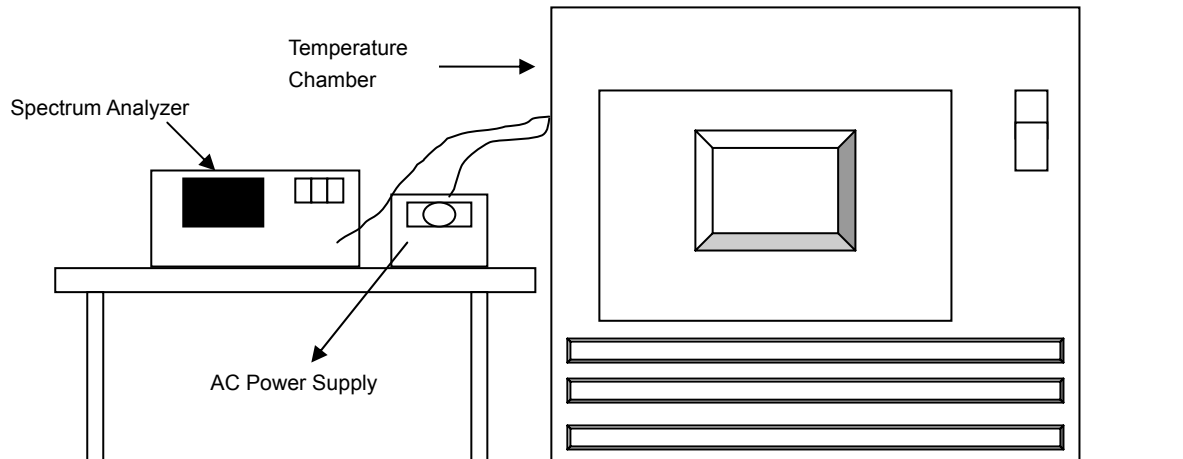

4.5.3 Test Instruments

Refer to section 4.1.2 to get information of above instrument.

4.5.4 Test Procedure

- The EUT was placed inside the environmental test chamber and powered by nominal AC voltage.
- Turn the EUT on and couple its output to a spectrum analyzer.
- Turn the EUT off and set the chamber to the highest temperature specified.
- Allow sufficient time (approximately 30 min) for the temperature of the chamber to stabilize, turn the EUT on and measure the operating frequency after 2, 5, and 10 Minutes.
- Repeat step 2 and 3 with the temperature chamber set to the lowest temperature.
- The test chamber was allowed to stabilize at +20 degree C for a minimum of 30 Minutes. The supply voltage was then adjusted on the EUT from 85% to 115% and the frequency record.

4.5.5 Deviation from Test Standard

No deviation.

4.5.6 EUT Operating Condition

Set the EUT transmit at un-modulation mode to test frequency stability.

4.5.7 Test Results

CDD Mode

FREQUENCY STABILITY VERSUS TEMP.									
OPERATING FREQUENCY: 5180MHz									
TEMP. (°C)	POWER SUPPLY (Vac)	0 MINUTE		2 MINUTE		5 MINUTE		10 MINUTE	
		Measured Frequency(MHz)	Frequency Drift (ppm)	Measured Frequency(MHz)	Frequency Drift (ppm)	Measured Frequency(MHz)	Frequency Drift (ppm)	Measured Frequency(MHz)	Frequency Drift (ppm)
50	120	5180.043114	8.3231401	5180.043139	8.3279779	5180.043033	8.3075923	5180.043041	8.3089885
40	120	5180.043418	8.3819428	5180.043675	8.4314801	5180.043510	8.3997008	5180.043677	8.4318959
30	120	5180.042434	8.1919462	5180.042267	8.1597332	5180.042717	8.2465068	5180.042181	8.1429791
20	120	5180.043163	8.3326669	5180.042985	8.2981969	5180.043252	8.3498435	5180.043143	8.3288371
10	120	5180.043083	8.3170988	5180.043719	8.4399009	5180.043433	8.3846581	5180.043325	8.3639550
0	120	5180.042446	8.1941891	5180.042142	8.1354301	5180.042376	8.1807637	5180.042689	8.2410267
-10	120	5180.043059	8.3125745	5180.0434	8.3783934	5180.043203	8.3403613	5180.043058	8.3123446
-20	120	5180.043087	8.3179314	5180.043001	8.3013821	5180.043238	8.3471961	5180.043339	8.3666280

FREQUENCY STABILITY VERSUS VOLTAGE									
OPERATING FREQUENCY: 5180MHz									
TEMP. (°C)	POWER SUPPLY (Vac)	0 MINUTE		2 MINUTE		5 MINUTE		10 MINUTE	
		Measured Frequency(MHz)	Frequency Drift (ppm)	Measured Frequency(MHz)	Frequency Drift (ppm)	Measured Frequency(MHz)	Frequency Drift (ppm)	Measured Frequency(MHz)	Frequency Drift (ppm)
20	138	5180.042676	8.2386433	5180.042435	8.1920049	5180.042481	8.2009560	5180.042491	8.2028891
	120	5180.043163	8.3326669	5180.042985	8.2981969	5180.043252	8.3498435	5180.043143	8.3288371
	102	5180.042836	8.2695330	5180.043005	8.3020534	5180.042966	8.2946419	5180.043206	8.3410174

4.6 6dB Bandwidth Measurement

4.6.1 Limits of 6dB Bandwidth Measurement

The minimum of 6dB Bandwidth Measurement is 0.5MHz.

4.6.2 Test Setup

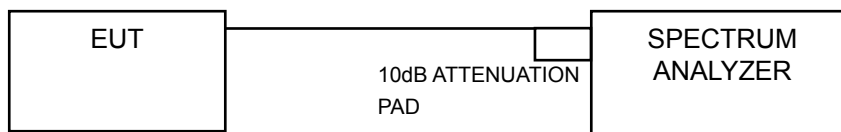

4.6.3 Test Instruments

Refer to section 4.1.2 to get information of above instrument.

4.6.4 Test Procedure

MEASUREMENT PROCEDURE REF

- Set resolution bandwidth (RBW) = 100kHz
- Set the video bandwidth (VBW) $\geq 3 \times$ RBW, Detector = Peak.
- Trace mode = max hold.
- Sweep = auto couple.
- Measure the maximum width of the emission that is constrained by the frequencies associated with the two amplitude points (upper and lower) that are attenuated by 6 dB relative to the maximum level measured in the fundamental emission

4.6.5 Deviation from Test Standard

No deviation.

4.6.6 EUT Operating Condition

The software provided by client to enable the EUT under transmission condition continuously at lowest, middle and highest channel frequencies individually.

4.6.7 Test Results

CDD Mode

802.11a

Channel	Frequency (MHz)	6dB Bandwidth (MHz)				Minimum Limit (MHz)	Pass / Fail
		Chain 0	Chain 1	Chain 2	Chain 3		
149	5745	15.17	15.18	15.18	15.20	0.5	Pass
157	5785	15.17	15.18	15.17	15.17	0.5	Pass
165	5825	15.18	15.19	15.19	15.19	0.5	Pass

802.11ac (20MHz)

Channel	Frequency (MHz)	6dB Bandwidth (MHz)				Minimum Limit (MHz)	Pass / Fail
		Chain 0	Chain 1	Chain 2	Chain 3		
149	5745	15.19	15.20	15.20	15.20	0.5	Pass
157	5785	15.20	15.20	15.21	15.21	0.5	Pass
165	5825	15.21	15.19	15.20	15.19	0.5	Pass

802.11ac (40MHz)

Channel	Frequency (MHz)	6dB Bandwidth (MHz)				Minimum Limit (MHz)	Pass / Fail
		Chain 0	Chain 1	Chain 2	Chain 3		
151	5755	35.09	35.19	35.18	35.14	0.5	Pass
159	5795	35.18	35.18	35.18	35.11	0.5	Pass

802.11ac (80MHz)

Channel	Frequency (MHz)	6dB Bandwidth (MHz)				Minimum Limit (MHz)	Pass / Fail
		Chain 0	Chain 1	Chain 2	Chain 3		
155	5775	72.63	72.82	72.81	72.83	0.5	Pass

Spectrum Plot of Worst Value

802.11a

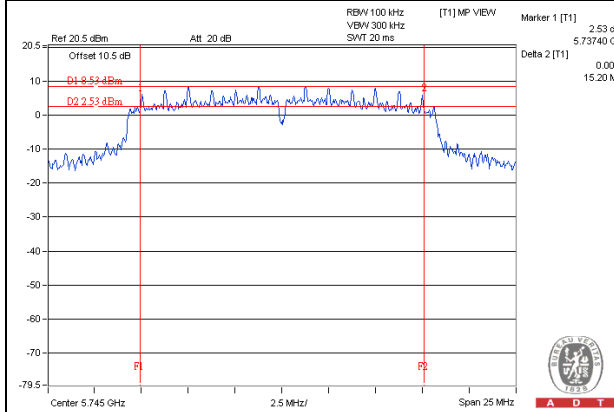

802.11ac (20MHz)

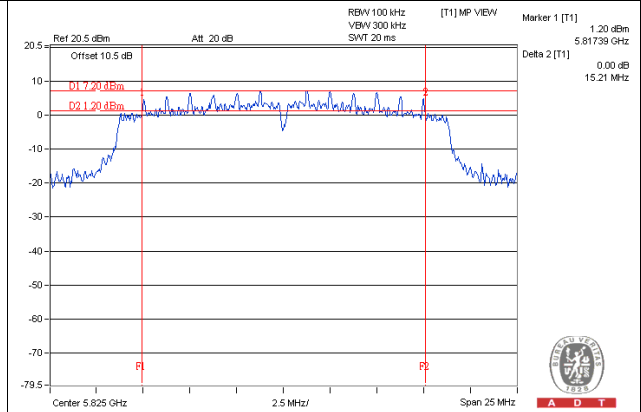

802.11ac (40MHz)

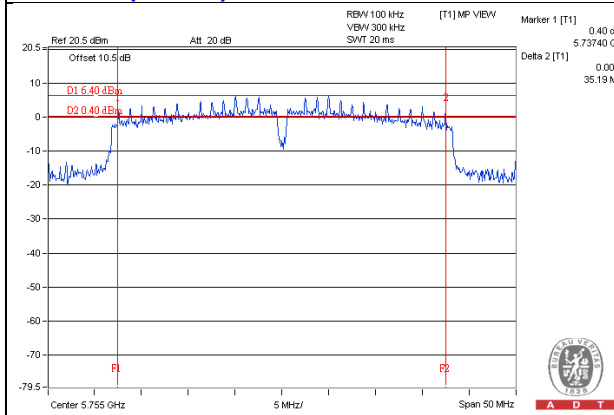

802.11ac (80MHz)

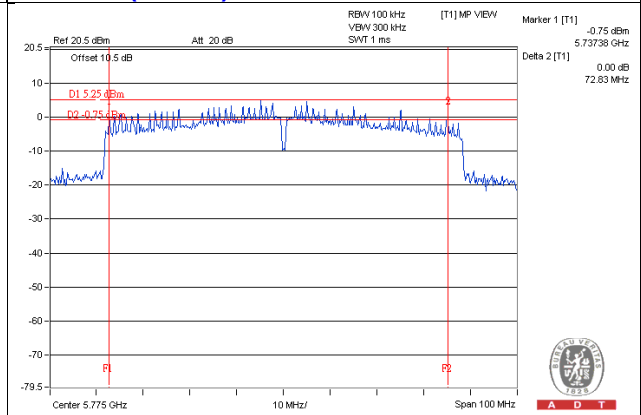

5 Pictures of Test Arrangements

Please refer to the attached file (Test Setup Photo).

Annex A- Radiated Out of Band Emisison (OOBE) Measurement (For U-NII-3 band)

CDD Mode

802.11a

Test Plots

Channel 149

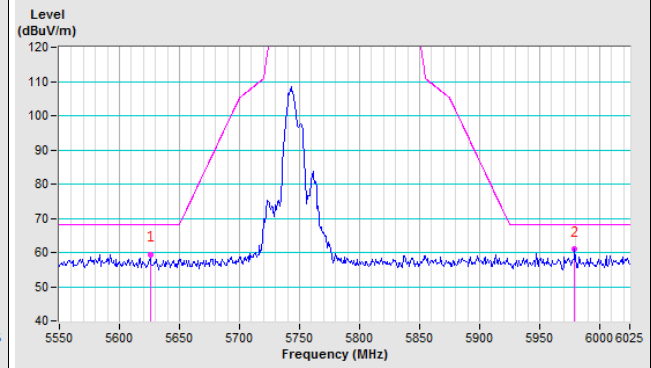
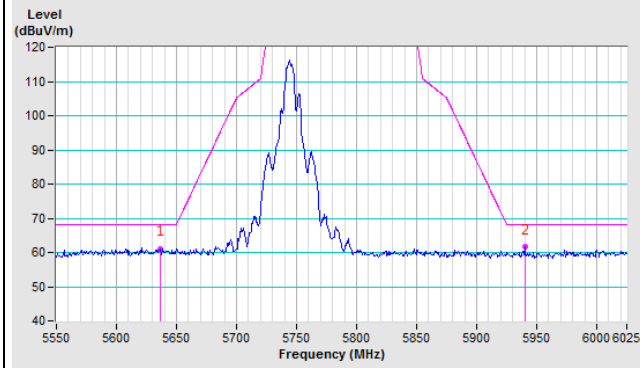

Channel 157

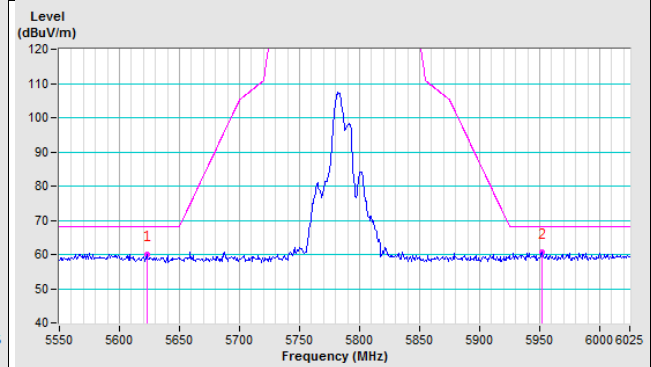
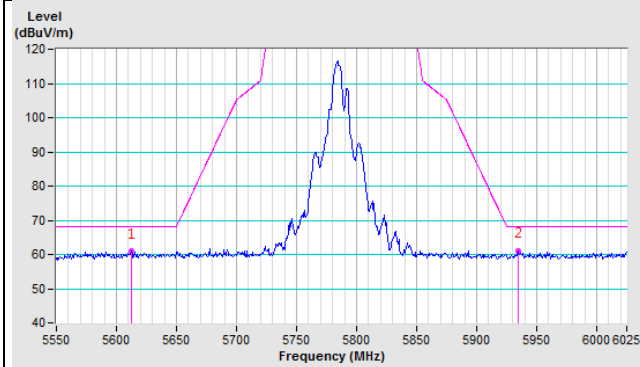

Channel 165

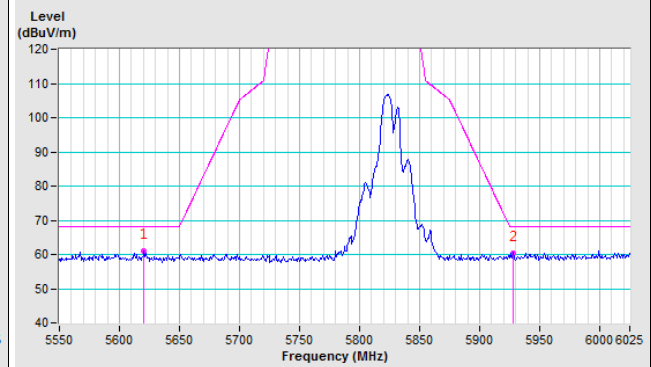
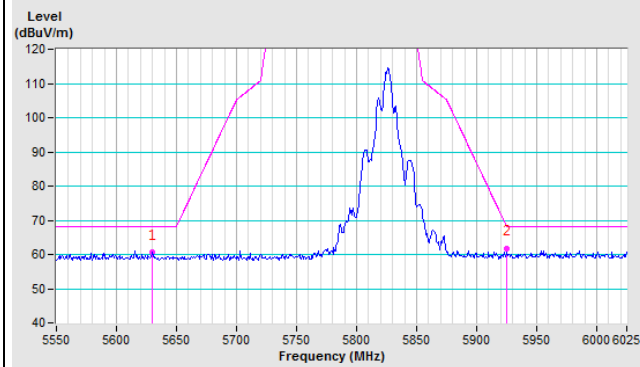

802.11ac (20MHz)

Test Plots

Channel 149

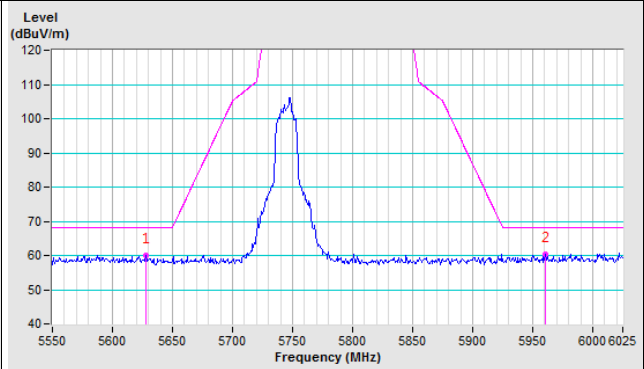
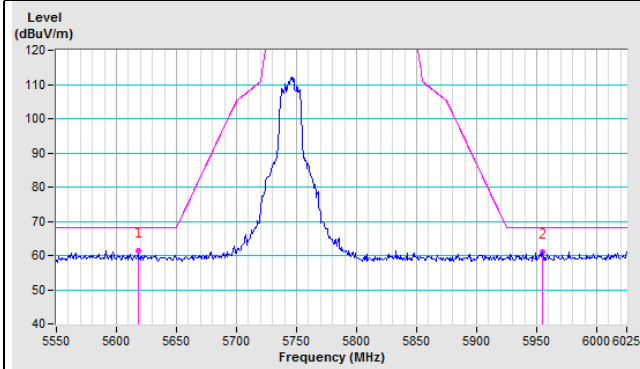

Channel 157

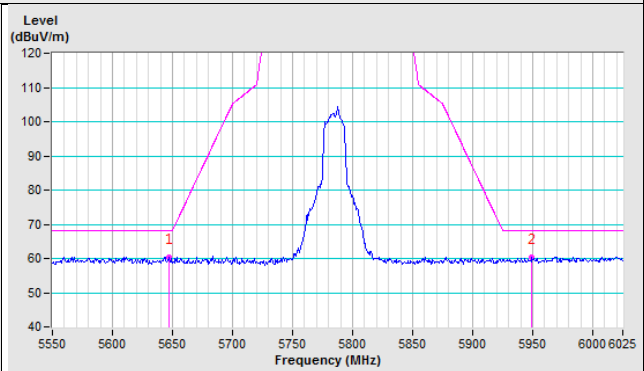
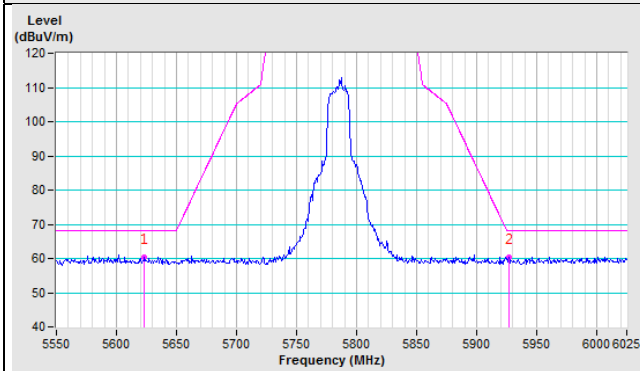

Channel 165

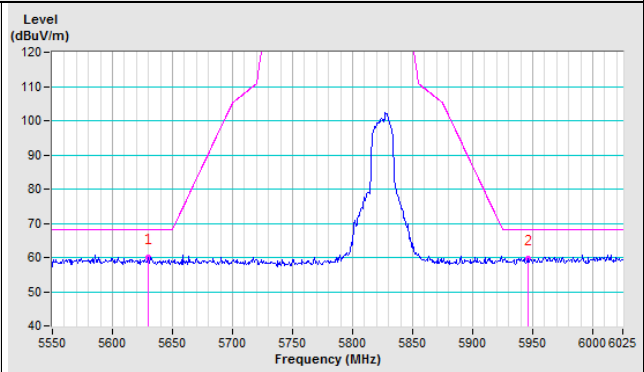
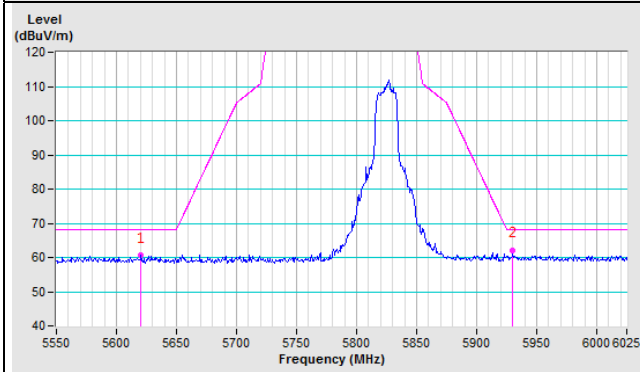

802.11ac (40MHz)

Test Plots

Channel 151

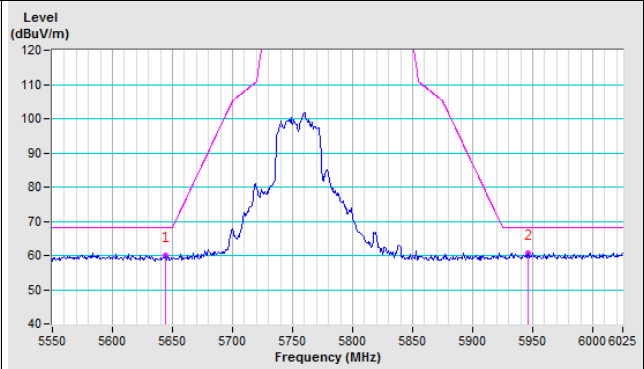
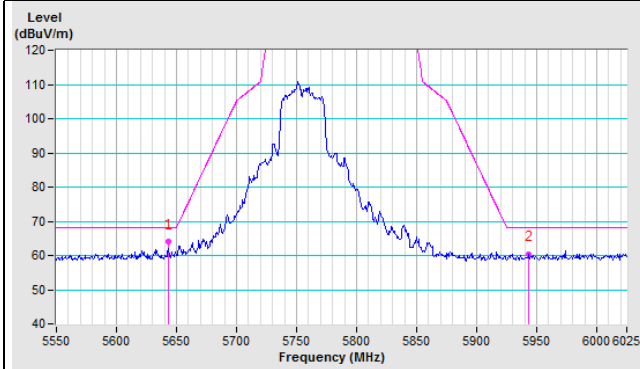

Channel 159

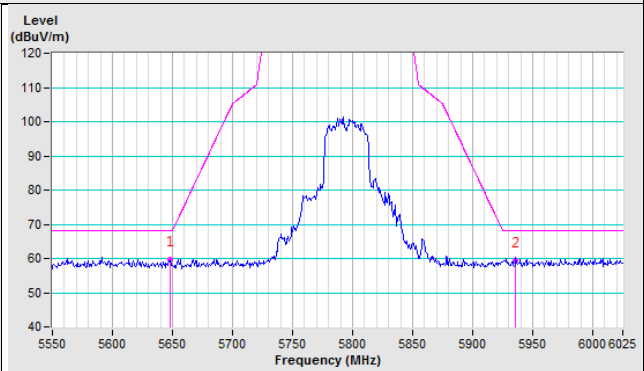
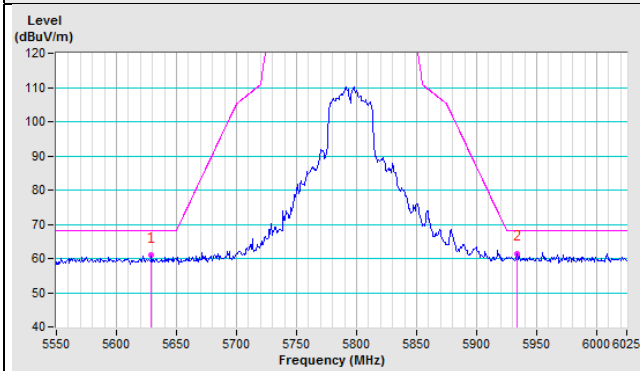

802.11ac (80MHz)

Test Plots

Channel 155

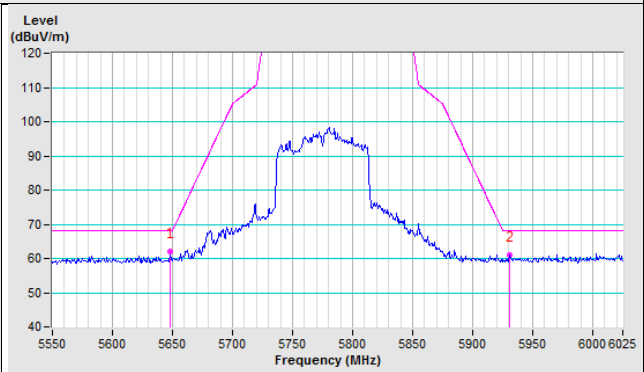
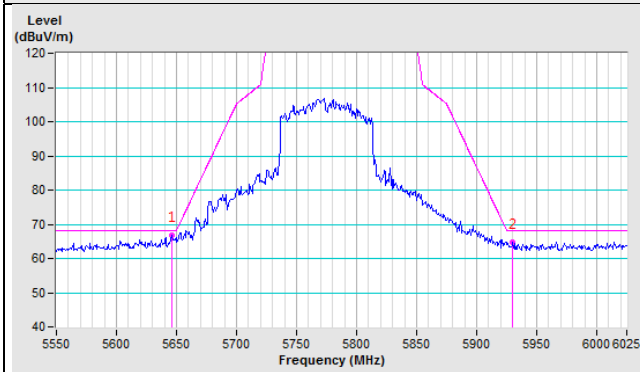

Beamforming Mode
802.11ac (20MHz)

Test Plots

Channel 149

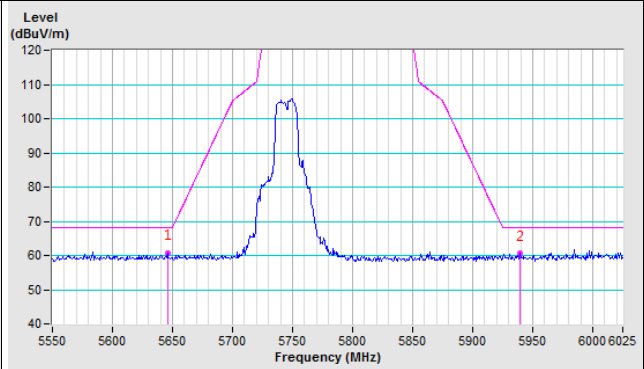
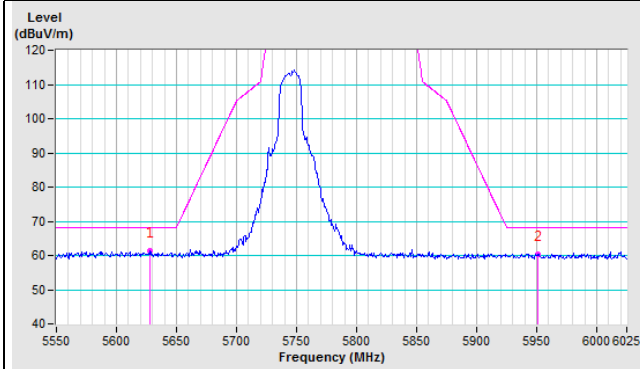

Channel 157

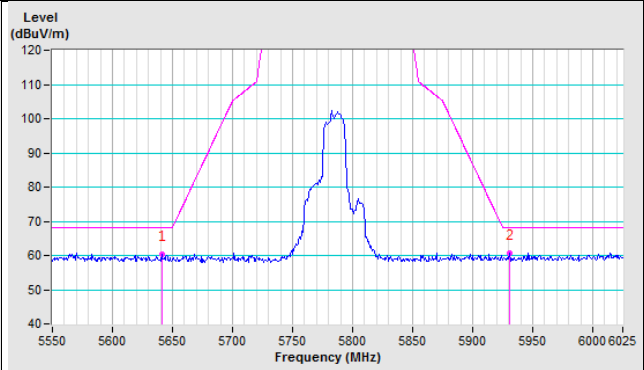
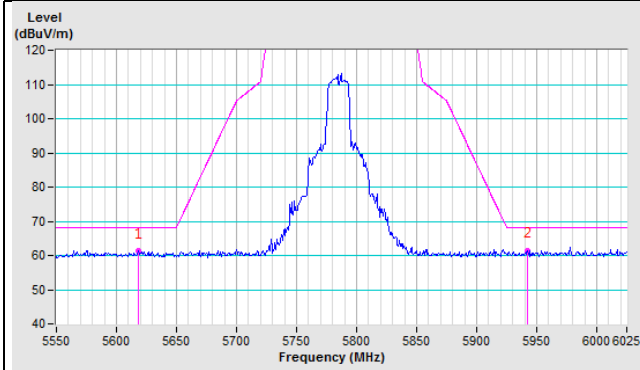

Channel 165

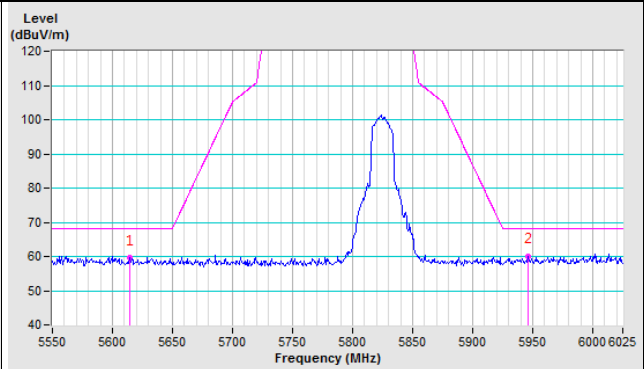
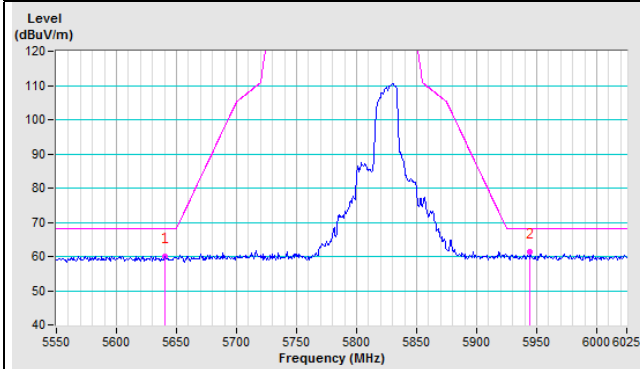

802.11ac (40MHz)

Test Plots

Channel 151

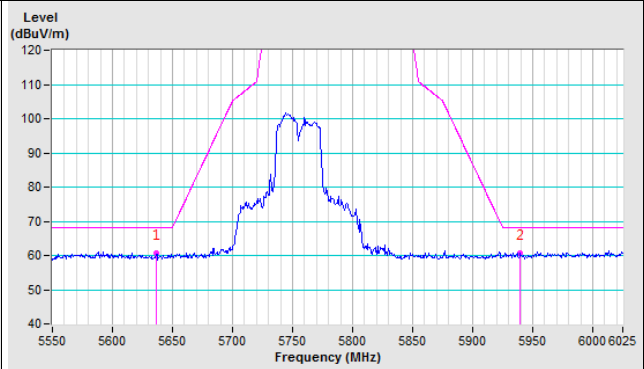
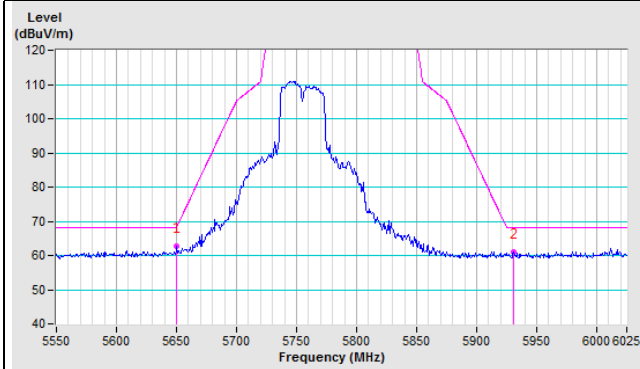

Channel 159

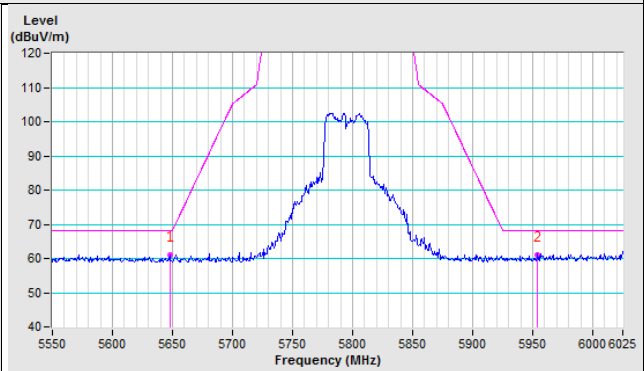
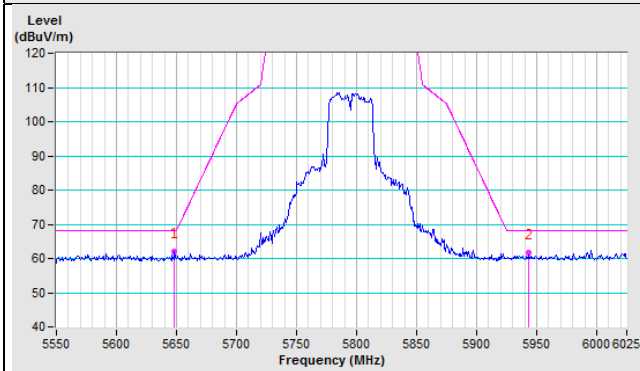

802.11ac (80MHz)

Test Plots

Channel 155

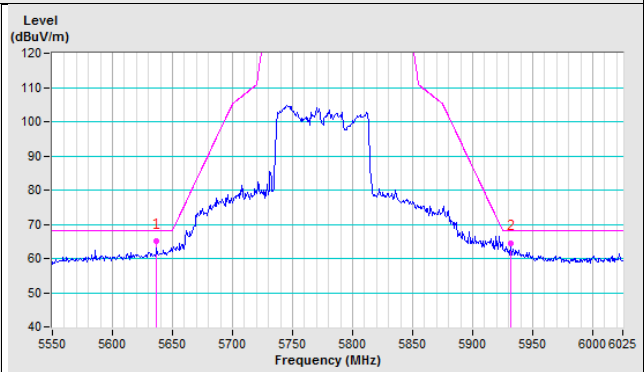
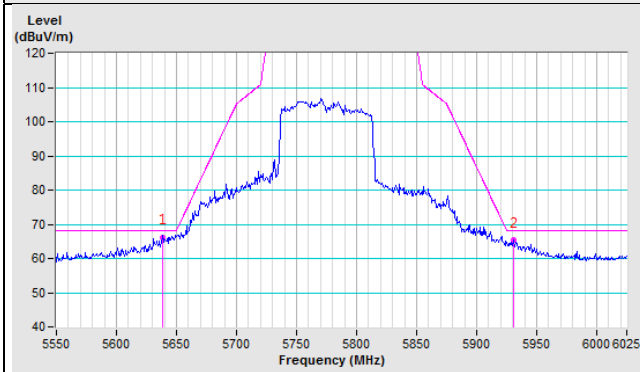

Appendix – Information on the Testing Laboratories

We, Bureau Veritas Consumer Products Services (H.K.) Ltd., Taoyuan Branch, were founded in 1988 to provide our best service in EMC, Radio, Telecom and Safety consultation. Our laboratories are accredited and approved according to ISO/IEC 17025.

If you have any comments, please feel free to contact us at the following:

Linko EMC/RF Lab

Tel: 886-2-26052180

Fax: 886-2-26051924

Hsin Chu EMC/RF/Telecom Lab

Tel: 886-3-6668565

Fax: 886-3-6668323

Hwa Ya EMC/RF/Safety Lab

Tel: 886-3-3183232

Fax: 886-3-3270892

Email: service.adt@tw.bureauveritas.com

Web Site: www.bureauveritas-adt.com

The address and road map of all our labs can be found in our web site also.

--- END ---