

EUT	AX6000 Wi-Fi 6 SOHO Router	Date of Test	2025-03-31
Factor	DRH18-E	Temp. / Humidity	24°C /59%
Polarity	Vertical	Site / Test Engineer	AC2 / Yang
Test Mode	802.11ax-40MHz_TX_CH 6_Ant 0+1+2+3	Test Voltage	AC 120V/60Hz

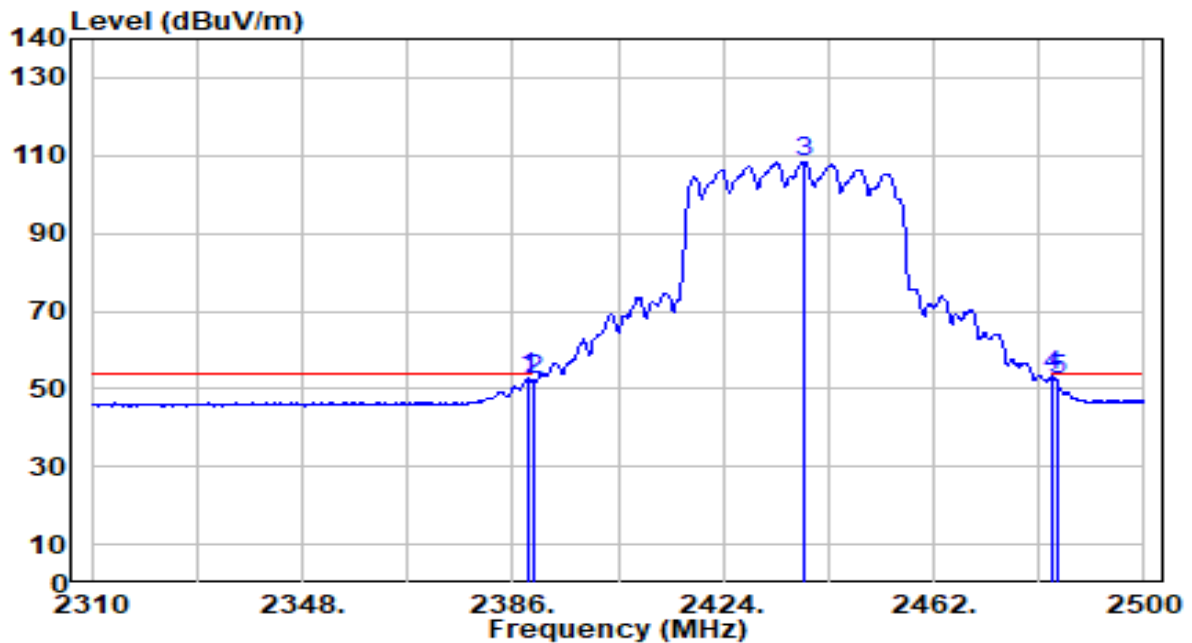

No	Frequency (MHz)	Reading (dBuV)	C.F (dB/m)	Measurement (dBuV/m)	Margin (dB)	Limit (dBuV/m)	Height (cm)	Angle (deg)	Remark (QP/PK/AV)
1	2388.850	21.59	31.42	53.01	-0.99	54.00	150	230	Average
2	2390.000	20.89	31.43	52.32	-1.68	54.00	150	230	Average
3	2438.440	76.92	31.57	108.49	N/A	N/A	150	230	Average
4	* 2483.500	21.50	31.71	53.21	-0.79	54.00	150	230	Average
5	2484.230	20.68	31.71	52.39	-1.61	54.00	150	230	Average

Note:

1. " *", means this data is the worst emission level.
2. C.F (Correction Factor) = Antenna Factor (dB/m)+ Cable Loss (dB).
3. Measurement (dBuV/m) = Reading(dBuV) + C.F (Correction Factor).
4. The emission levels of other frequencies are very lower than the limit and not show in test report.

EUT	AX6000 Wi-Fi 6 SOHO Router	Date of Test	2025-05-24
Factor	DRH18-E	Temp. / Humidity	24°C /59%
Polarity	Horizontal	Site / Test Engineer	AC2 / Stanley
Test Mode	802.11ax-40MHz_TX_CH 8_Ant 0+1+2+3	Test Voltage	AC 120V/60Hz

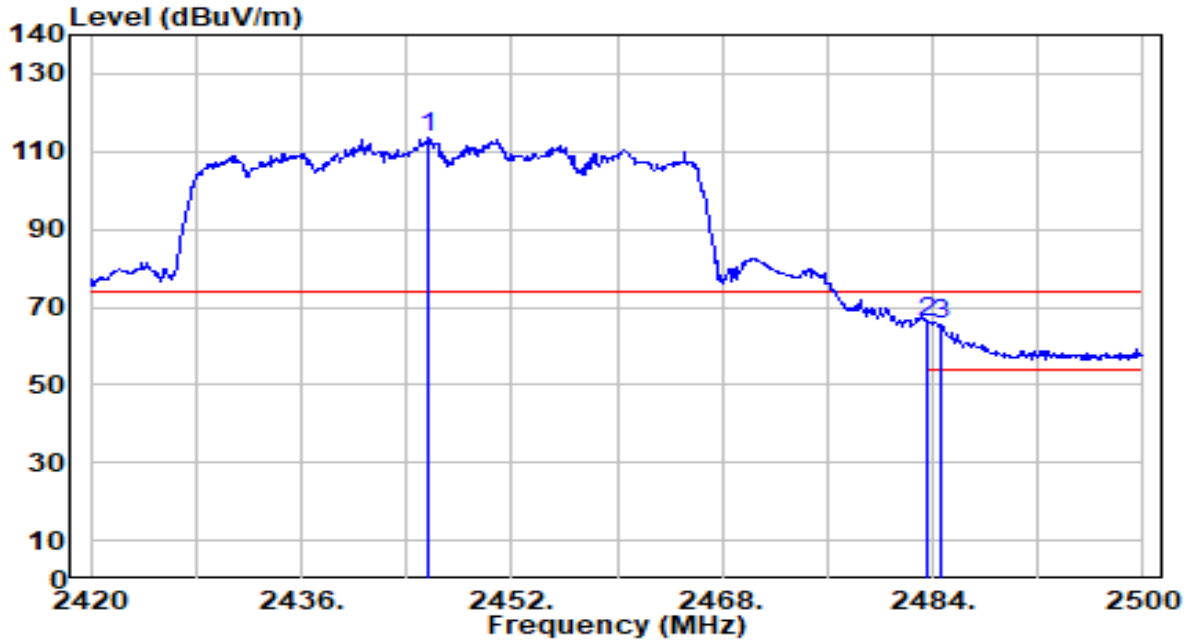

No	Frequency (MHz)	Reading (dBuV)	C.F (dB/m)	Measurement (dBuV/m)	Margin (dB)	Limit (dBuV/m)	Height (cm)	Angle (deg)	Remark (QP/PK/AV)
1	2445.600	81.77	31.59	113.36	N/A	N/A	100	151	Peak
2	* 2483.500	34.37	31.71	66.08	-7.92	74.00	100	151	Peak
3	2484.560	33.69	31.71	65.40	-8.60	74.00	100	151	Peak

Note:

1. " *", means this data is the worst emission level.
2. C.F (Correction Factor) = Antenna Factor (dB/m) + Cable Loss (dB).
3. Measurement (dBuV/m) = Reading(dBuV) + C.F (Correction Factor).
4. The emission levels of other frequencies are very lower than the limit and not show in test report.

EUT	AX6000 Wi-Fi 6 SOHO Router	Date of Test	2025-05-24
Factor	DRH18-E	Temp. / Humidity	24°C /59%
Polarity	Horizontal	Site / Test Engineer	AC2 / Stanley
Test Mode	802.11ax-40MHz_TX_CH 8_Ant 0+1+2+3	Test Voltage	AC 120V/60Hz

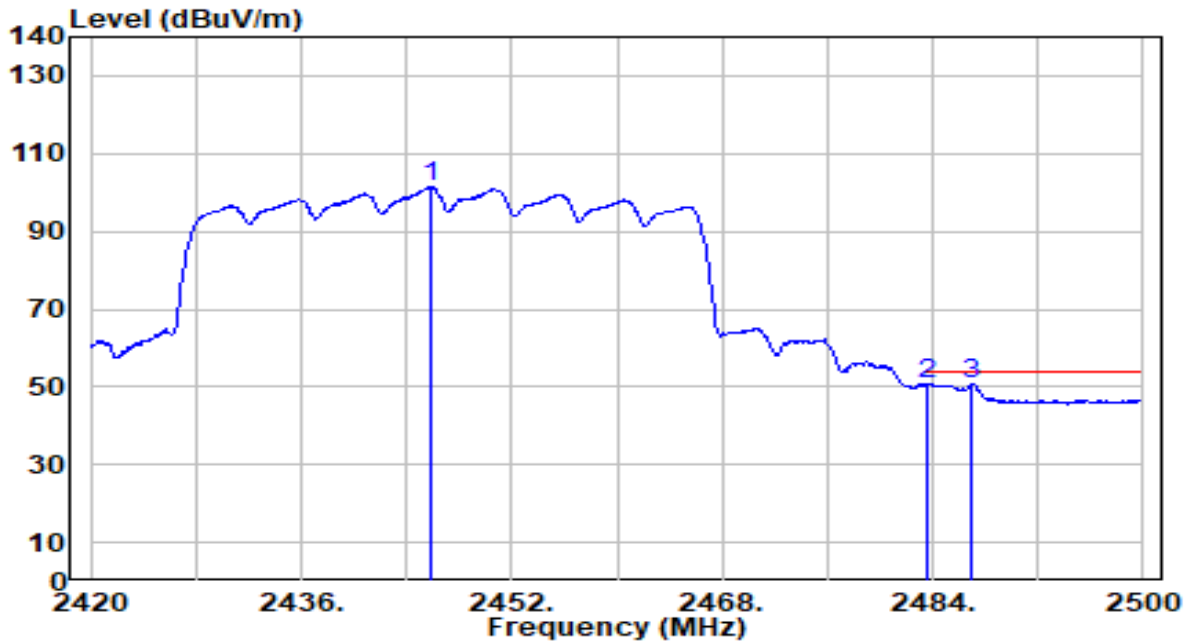

No	Frequency (MHz)	Reading (dBuV)	C.F (dB/m)	Measurement (dBuV/m)	Margin (dB)	Limit (dBuV/m)	Height (cm)	Angle (deg)	Remark (QP/PK/AV)
1	2445.760	69.89	31.60	101.49	N/A	N/A	100	151	Average
2	2483.500	18.76	31.71	50.47	-3.53	54.00	100	151	Average
3	* 2486.960	19.10	31.72	50.82	-3.18	54.00	100	151	Average

Note:

1. " *", means this data is the worst emission level.
2. C.F (Correction Factor) = Antenna Factor (dB/m) + Cable Loss (dB).
3. Measurement (dBuV/m) = Reading(dBuV) + C.F (Correction Factor).
4. The emission levels of other frequencies are very lower than the limit and not show in test report.

EUT	AX6000 Wi-Fi 6 SOHO Router	Date of Test	2025-05-24
Factor	DRH18-E	Temp. / Humidity	24°C /59%
Polarity	Vertical	Site / Test Engineer	AC2 / Stanley
Test Mode	802.11ax-40MHz_TX_CH 8_Ant 0+1+2+3	Test Voltage	AC 120V/60Hz

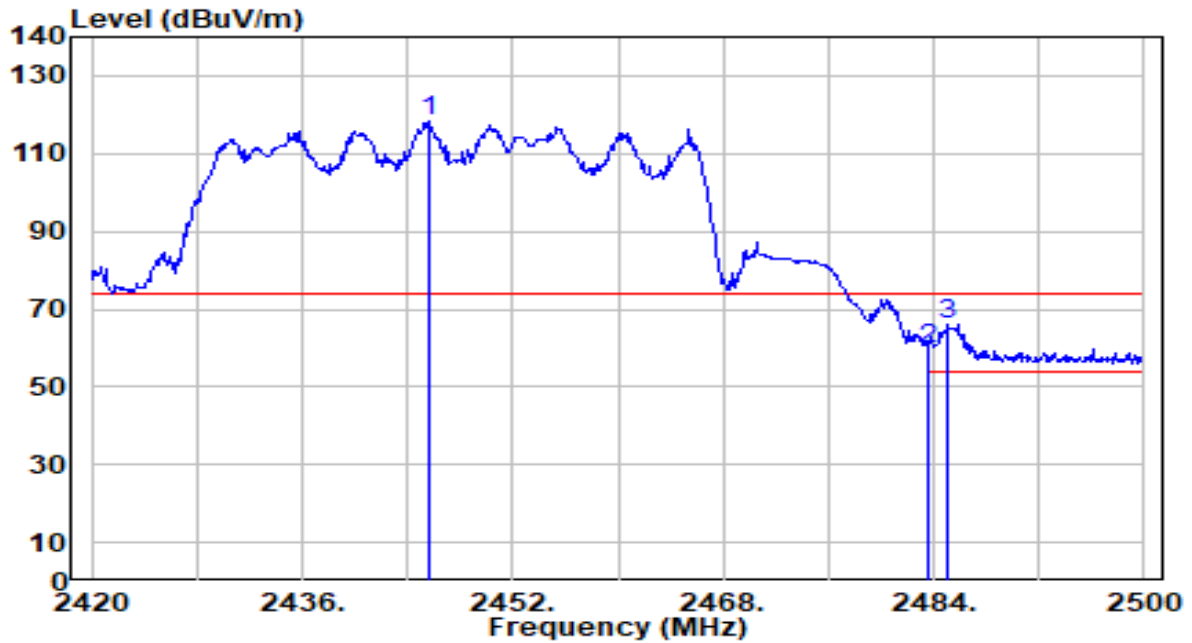

No	Frequency (MHz)	Reading (dBuV)	C.F (dB/m)	Measurement (dBuV/m)	Margin (dB)	Limit (dBuV/m)	Height (cm)	Angle (deg)	Remark (QP/PK/AV)
1	2445.680	86.55	31.59	118.14	N/A	N/A	156	204	Peak
2	2483.500	28.12	31.71	59.83	-14.17	74.00	156	204	Peak
3	* 2485.040	34.32	31.71	66.04	-7.96	74.00	156	204	Peak

Note:

1. " *", means this data is the worst emission level.
2. C.F (Correction Factor) = Antenna Factor (dB/m) + Cable Loss (dB).
3. Measurement (dBuV/m) = Reading(dBuV) + C.F (Correction Factor).
4. The emission levels of other frequencies are very lower than the limit and not show in test report.

EUT	AX6000 Wi-Fi 6 SOHO Router	Date of Test	2025-05-24
Factor	DRH18-E	Temp. / Humidity	24°C /59%
Polarity	Vertical	Site / Test Engineer	AC2 / Stanley
Test Mode	802.11ax-40MHz_TX_CH 8_Ant 0+1+2+3	Test Voltage	AC 120V/60Hz

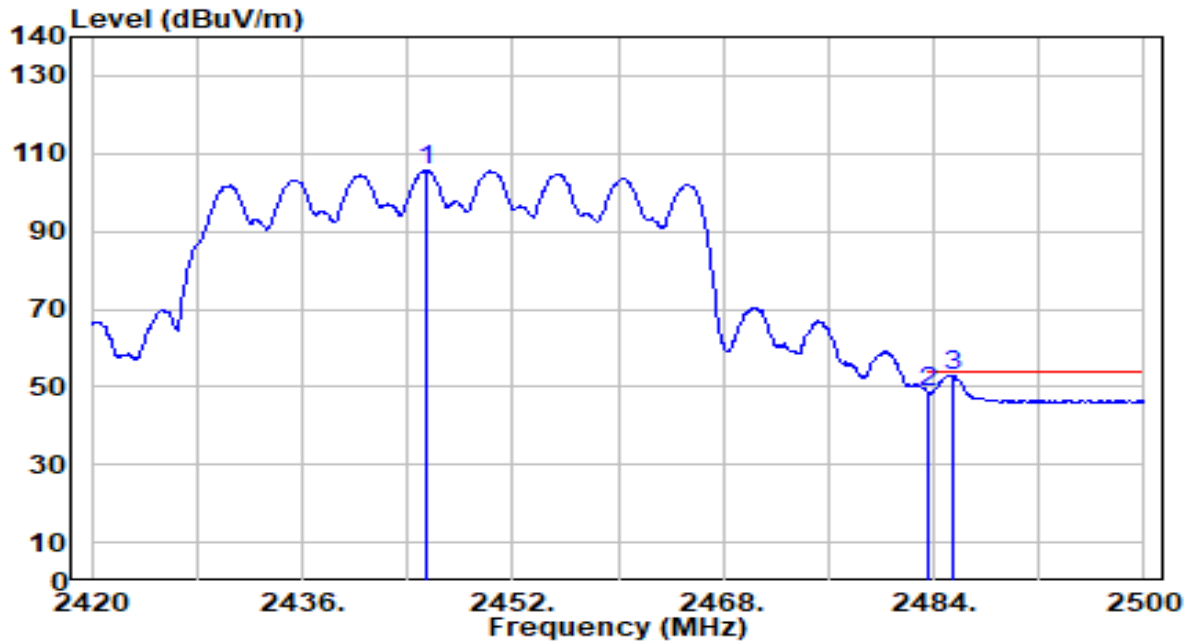

No	Frequency (MHz)	Reading (dBuV)	C.F (dB/m)	Measurement (dBuV/m)	Margin (dB)	Limit (dBuV/m)	Height (cm)	Angle (deg)	Remark (QP/PK/AV)
1	2445.440	74.05	31.59	105.64	N/A	N/A	156	204	Average
2	2483.500	17.11	31.71	48.82	-5.18	54.00	156	204	Average
3	* 2485.440	21.34	31.72	53.05	-0.95	54.00	156	204	Average

Note:

1. " *", means this data is the worst emission level.
2. C.F (Correction Factor) = Antenna Factor (dB/m) + Cable Loss (dB).
3. Measurement (dBuV/m) = Reading(dBuV) + C.F (Correction Factor).
4. The emission levels of other frequencies are very lower than the limit and not show in test report.

EUT	AX6000 Wi-Fi 6 SOHO Router	Date of Test	2025-03-31
Factor	DRH18-E	Temp. / Humidity	24°C /59%
Polarity	Horizontal	Site / Test Engineer	AC2 / Yang
Test Mode	802.11ax-40MHz_TX_CH 9_Ant 0+1+2+3	Test Voltage	AC 120V/60Hz

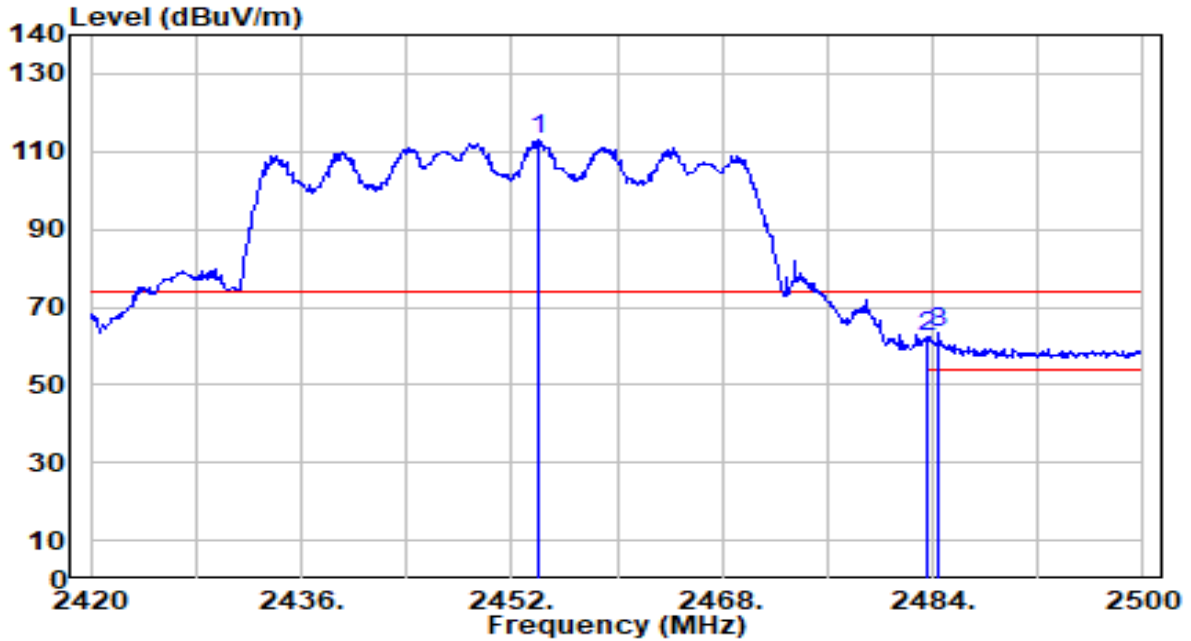

No	Frequency (MHz)	Reading (dBuV)	C.F (dB/m)	Measurement (dBuV/m)	Margin (dB)	Limit (dBuV/m)	Height (cm)	Angle (deg)	Remark (QP/PK/AV)
1	2454.080	81.37	31.62	112.99	N/A	N/A	174	126	Peak
2	2483.500	30.77	31.71	62.48	-11.52	74.00	174	126	Peak
3	* 2484.400	31.45	31.71	63.16	-10.84	74.00	174	126	Peak

Note:

1. " *", means this data is the worst emission level.
2. C.F (Correction Factor) = Antenna Factor (dB/m)+ Cable Loss (dB).
3. Measurement (dBuV/m) = Reading(dBuV) + C.F (Correction Factor).
4. The emission levels of other frequencies are very lower than the limit and not show in test report.

EUT	AX6000 Wi-Fi 6 SOHO Router	Date of Test	2025-03-31
Factor	DRH18-E	Temp. / Humidity	24°C /59%
Polarity	Horizontal	Site / Test Engineer	AC2 / Yang
Test Mode	802.11ax-40MHz_TX_CH 9_Ant 0+1+2+3	Test Voltage	AC 120V/60Hz

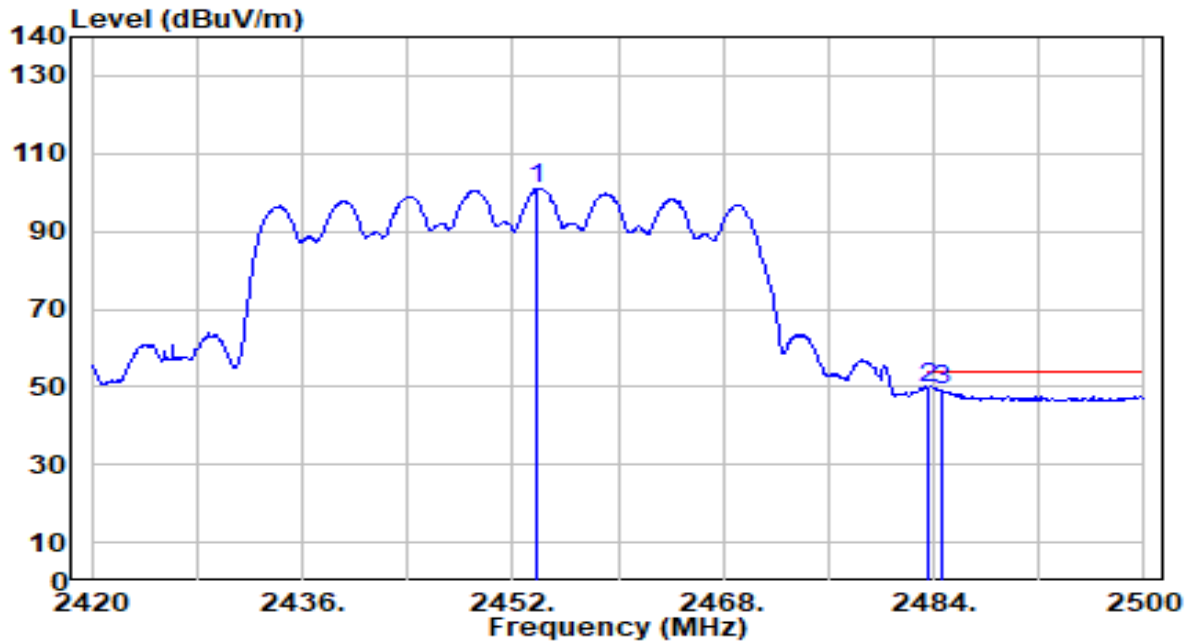

No	Frequency (MHz)	Reading (dBuV)	C.F (dB/m)	Measurement (dBuV/m)	Margin (dB)	Limit (dBuV/m)	Height (cm)	Angle (deg)	Remark (QP/PK/AV)
1	2453.920	69.49	31.62	101.11	N/A	N/A	174	126	Average
2	* 2483.500	18.12	31.71	49.83	-4.17	54.00	174	126	Average
3	2484.560	17.44	31.71	49.15	-4.85	54.00	174	126	Average

Note:

1. " *", means this data is the worst emission level.
2. C.F (Correction Factor) = Antenna Factor (dB/m)+ Cable Loss (dB).
3. Measurement (dBuV/m) = Reading(dBuV) + C.F (Correction Factor).
4. The emission levels of other frequencies are very lower than the limit and not show in test report.

EUT	AX6000 Wi-Fi 6 SOHO Router	Date of Test	2025-03-31
Factor	DRH18-E	Temp. / Humidity	24°C /59%
Polarity	Vertical	Site / Test Engineer	AC2 / Yang
Test Mode	802.11ax-40MHz_TX_CH 9_Ant 0+1+2+3	Test Voltage	AC 120V/60Hz

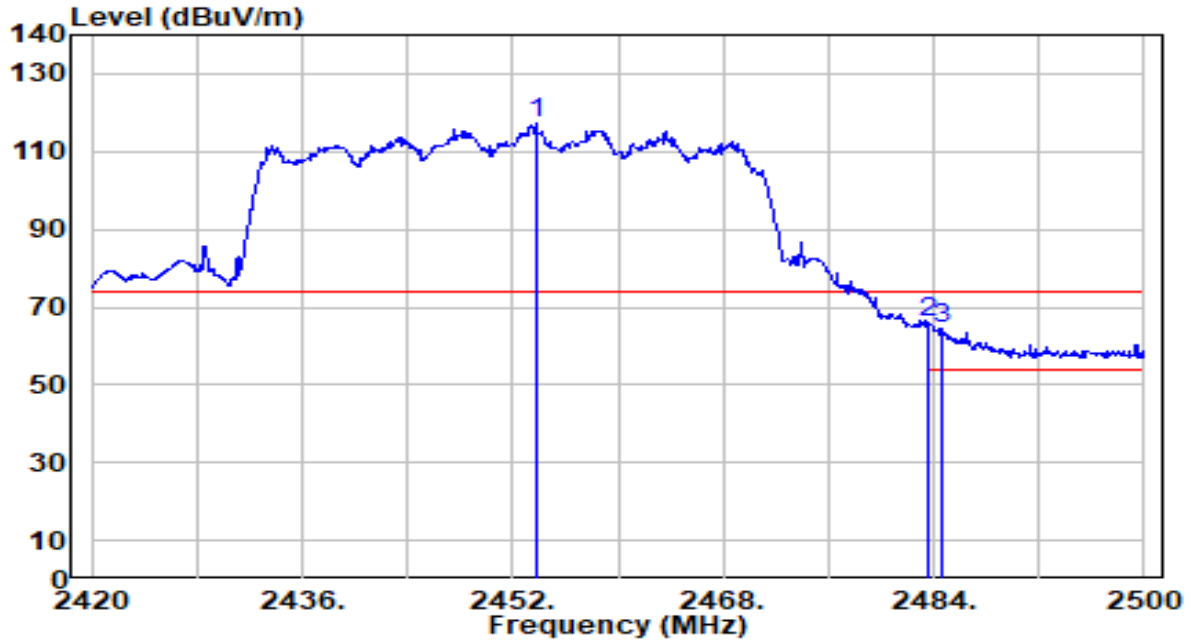

No	Frequency (MHz)	Reading (dBuV)	C.F (dB/m)	Measurement (dBuV/m)	Margin (dB)	Limit (dBuV/m)	Height (cm)	Angle (deg)	Remark (QP/PK/AV)
1	2453.760	85.41	31.62	117.03	N/A	N/A	159	232	Peak
2	* 2483.500	34.33	31.71	66.04	-7.96	74.00	159	232	Peak
3	2484.720	32.66	31.71	64.38	-9.62	74.00	159	232	Peak

Note:

1. " *", means this data is the worst emission level.
2. C.F (Correction Factor) = Antenna Factor (dB/m)+ Cable Loss (dB).
3. Measurement (dBuV/m) = Reading(dBuV) + C.F (Correction Factor).
4. The emission levels of other frequencies are very lower than the limit and not show in test report.

EUT	AX6000 Wi-Fi 6 SOHO Router	Date of Test	2025-03-31
Factor	DRH18-E	Temp. / Humidity	24°C /59%
Polarity	Vertical	Site / Test Engineer	AC2 / Yang
Test Mode	802.11ax-40MHz_TX_CH 9_Ant 0+1+2+3	Test Voltage	AC 120V/60Hz

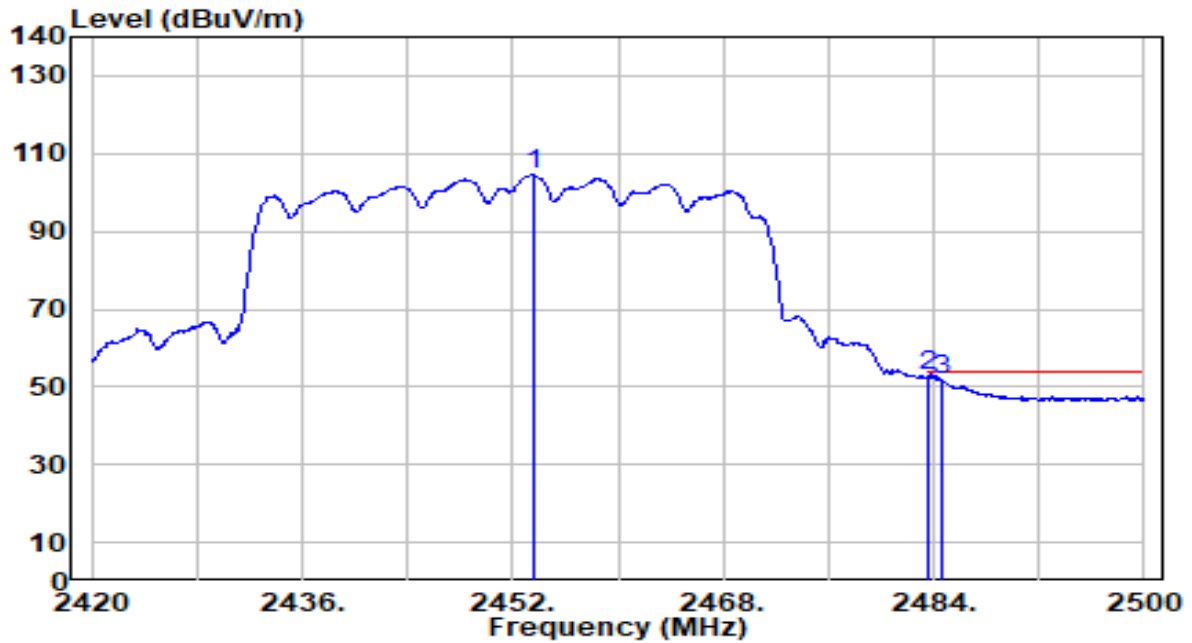

No	Frequency (MHz)	Reading (dBuV)	C.F (dB/m)	Measurement (dBuV/m)	Margin (dB)	Limit (dBuV/m)	Height (cm)	Angle (deg)	Remark (QP/PK/AV)
1	2453.520	72.96	31.62	104.58	N/A	N/A	159	232	Average
2	* 2483.500	21.33	31.71	53.04	-0.96	54.00	159	232	Average
3	2484.560	20.18	31.71	51.89	-2.11	54.00	159	232	Average

Note:

1. " *", means this data is the worst emission level.
2. C.F (Correction Factor) = Antenna Factor (dB/m)+ Cable Loss (dB).
3. Measurement (dBuV/m) = Reading(dBuV) + C.F (Correction Factor).
4. The emission levels of other frequencies are very lower than the limit and not show in test report.

7.8. AC Conducted Emissions Measurement

7.8.1. Test Limit

FCC Part 15 Subpart C Paragraph 15.207 Limits		
Frequency (MHz)	QP (dBuV)	AV (dBuV)
0.15 - 0.50	66 - 56	56 - 46
0.50 - 5.0	56	46
5.0 - 30	60	50

Note 1: The lower limit shall apply at the transition frequencies.

Note 2: The limit decreases linearly with the logarithm of the frequency in the range 0.15MHz to 0.5MHz.

7.8.2. Test Setup

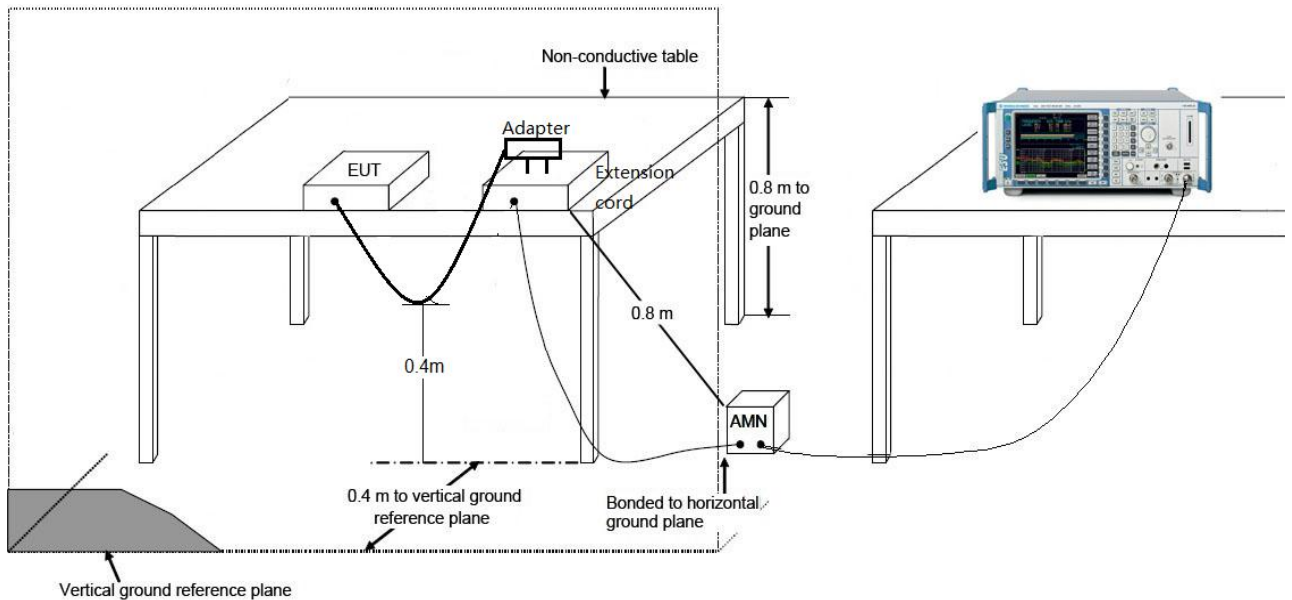

7.8.3. Test Result

EUT	AX6000 Wi-Fi 6 SOHO Router	Date of Test	2025-04-10
Factor	CE_ENV216-L1 (Filter ON)	Temp. / Humidity	23.5°C / 71%
Polarity	Line1	Site / Test Engineer	SR2 / Ryan
Test Mode	802.11n-20MHz_TX_CH6_Ant 0+1+2+3	Test Voltage	AC 120V/60Hz

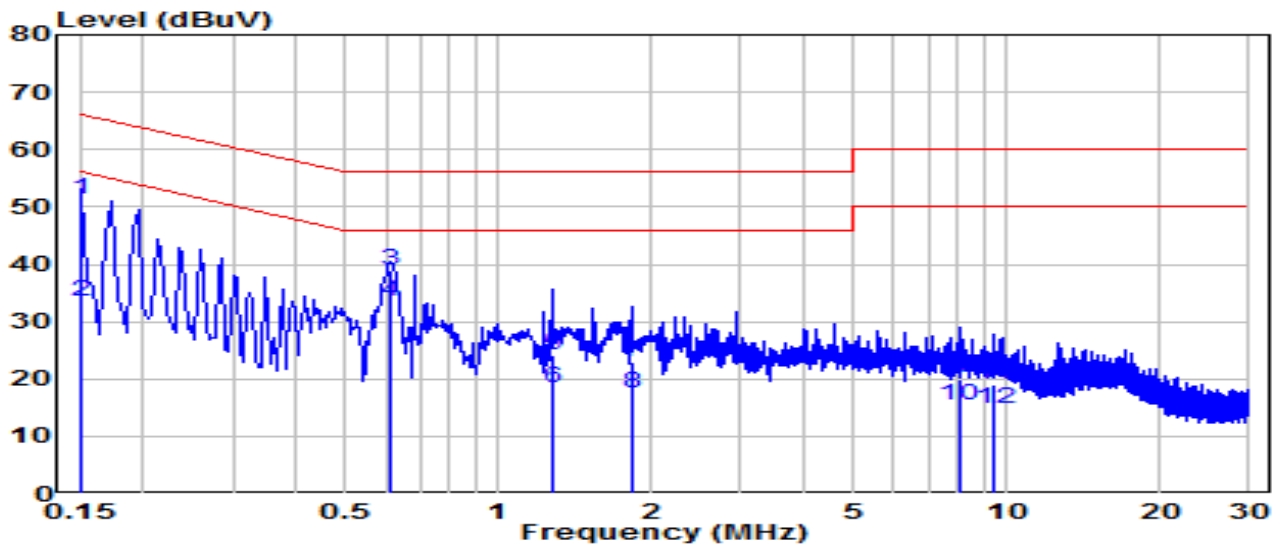

No	Frequency (MHz)	Reading (dBuV)	C.F (dB)	Measurement (dBuV)	Margin (dB)	Limit (dBuV)	Remark (QP/PK/AV)
1	0.150	41.77	9.63	51.40	-14.60	66.00	QP
2	0.150	24.00	9.63	33.63	-22.37	56.00	Average
3	* 0.609	29.25	9.65	38.90	-17.10	56.00	QP
4	* 0.609	24.01	9.65	33.66	-12.34	46.00	Average
5	1.275	14.62	9.68	24.30	-31.70	56.00	QP
6	1.275	8.80	9.68	18.47	-27.53	46.00	Average
7	1.824	13.29	9.69	22.99	-33.01	56.00	QP
8	1.824	7.68	9.69	17.37	-28.63	46.00	Average
9	8.042	10.17	9.82	19.99	-40.01	60.00	QP
10	8.042	5.59	9.82	15.42	-34.58	50.00	Average
11	9.437	9.30	9.86	19.16	-40.84	60.00	QP
12	9.437	4.88	9.86	14.73	-35.27	50.00	Average

Note:

1. " *", means this data is the worst emission level.
2. C.F (Correction Factor) = LISN Factor (dB)+ Cable Loss (dB).
3. Measurement (dBuV) = Reading(dBuV) + C.F (Correction Factor).

EUT	AX6000 Wi-Fi 6 SOHO Router	Date of Test	2025-04-10
Factor	CE_ENV216-N (Filter ON)	Temp. / Humidity	23.5°C /71%
Polarity	Neutral	Site / Test Engineer	SR2 / Ryan
Test Mode	802.11n-20MHz_TX_CH6_Ant 0+1+2+3	Test Voltage	AC 120V/60Hz

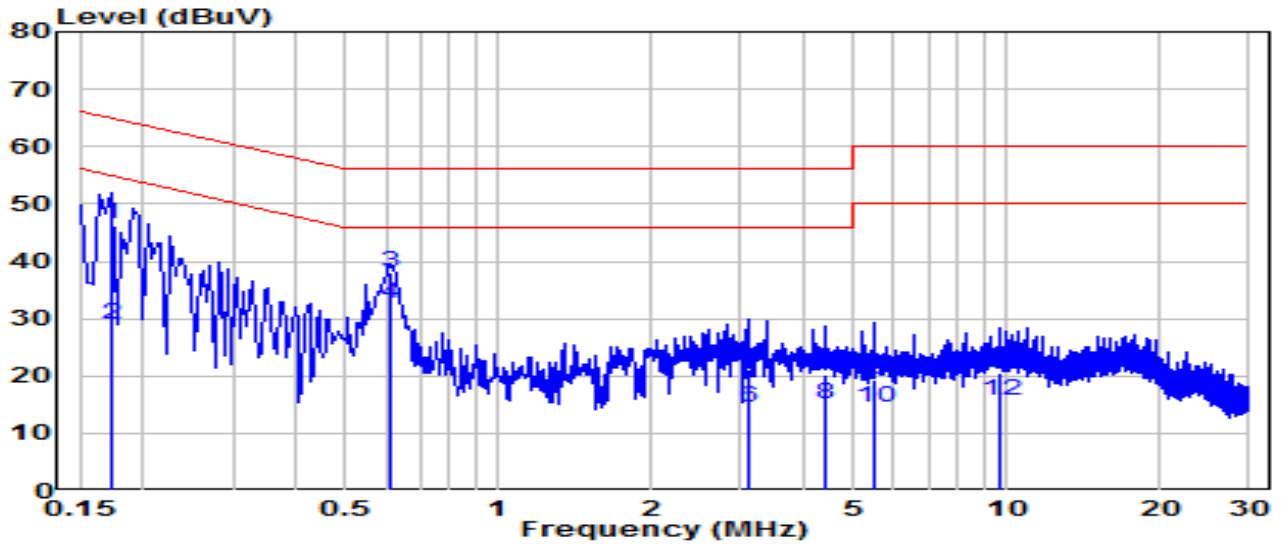

No	Frequency (MHz)	Reading (dBUV)	C.F (dB)	Measurement (dBUV)	Margin (dB)	Limit (dBUV)	Remark (QP/PK/AV)
1	0.172	36.80	9.63	46.43	-18.41	64.84	QP
2	0.172	19.35	9.63	28.97	-25.87	54.84	Average
3	* 0.609	28.30	9.65	37.94	-18.06	56.00	QP
4	* 0.609	22.97	9.65	32.62	-13.38	46.00	Average
5	3.097	11.38	9.72	21.09	-34.91	56.00	QP
6	3.097	4.87	9.72	14.58	-31.42	46.00	Average
7	4.380	10.50	9.74	20.23	-35.77	56.00	QP
8	4.380	5.23	9.74	14.96	-31.04	46.00	Average
9	5.500	9.67	9.76	19.43	-40.57	60.00	QP
10	5.500	4.87	9.76	14.63	-35.37	50.00	Average
11	9.698	10.68	9.86	20.54	-39.46	60.00	QP
12	9.698	5.95	9.86	15.81	-34.19	50.00	Average

Note:

1. " *", means this data is the worst emission level.
2. C.F (Correction Factor) = LISN Factor (dB)+ Cable Loss (dB).
3. Measurement (dBUV) = Reading(dBUV) + C.F (Correction Factor).

8. CONCLUSION

The data collected relate only the item(s) tested and show that the device is compliance with Part 15C of the FCC Rules.

Appendix A : Test Setup Photograph

Refer to “2502TWL805-UT” file.

Appendix B : External Photograph

Refer to “2502TWL805-UE” file.

Appendix C : Internal Photograph

Refer to “2502TWL805-UI” file.

————— The End —————