

# FCC Radio Test Report

## FCC ID:KA2AP1665B1

This report concerns (check one): Original Grant Class I Change Class II Change

**Project No.** : 1608C193  
**Equipment** : Wireless AC1200 Dual Band Access Point  
**Model Name** : DAP-1665  
**Applicant** : D-Link Corporation  
**Address** : No.289, Sinhu 3rd Rd., Neihu District, Taipei City 114,  
Taiwan, R.O.C.

**Date of Receipt** : Aug. 18, 2016  
**Date of Test** : Aug. 18, 2016 ~ Oct. 10, 2016  
**Issued Date** : Oct. 11, 2016  
**Tested by** : BTL Inc.

**Testing Engineer** : Shawn Xiao  
(Shawn Xiao)

**Technical Manager** : David Mao  
(David Mao)

**Authorized Signatory** : Steven Lu  
(Steven Lu)

# **B T L I N C .**

No.3, Jinshagang 1st Road, Shixia, Dalang Town, Dongguan,  
Guangdong, China.

TEL: +86-769-8318-3000 FAX: +86-769-8319-6000

**Declaration**

**BTL** represents to the client that testing is done in accordance with standard procedures as applicable and that test instruments used has been calibrated with standards traceable to international standard(s) and/or national standard(s).

**BTL's** reports apply only to the specific samples tested under conditions. It is manufacture's responsibility to ensure that additional production units of this model are manufactured with the identical electrical and mechanical components. **BTL** shall have no liability for any declarations, inferences or generalizations drawn by the client or others from **BTL** issued reports.

**BTL's** report must not be used by the client to claim product certification, approval, or endorsement by NVLAP, NIST, or any agency of the Federal Government.

This report is the confidential property of the client. As a mutual protection to the clients, the public and **BTL-self**, extracts from the test report shall not be reproduced except in full with **BTL's** authorized written approval.

**BTL's** laboratory quality assurance procedures are in compliance with the **ISO Guide17025** requirements, and accredited by the conformity assessment authorities listed in this test report.

**Limitation**

For the use of the authority's logo is limited unless the Test Standard(s)/Scope(s)/Item(s) mentioned in this test report is (are) included in the conformity assessment authorities acceptance respective.

**Table of Contents**

**Page**

<b>1 . CERTIFICATION</b>	<b>6</b>
<b>2 . SUMMARY OF TEST RESULTS</b>	<b>7</b>
2.1 TEST FACILITY	8
2.2 MEASUREMENT UNCERTAINTY	8
<b>3 . GENERAL INFORMATION</b>	<b>9</b>
3.1 GENERAL DESCRIPTION OF EUT	9
3.2 DESCRIPTION OF TEST MODES	10
3.3 TABLE OF PARAMETERS OF TEXT SOFTWARE SETTING	13
3.4 BLOCKDIAGRAMSHOWINGTHECONFIGURATIONOFSYSTEMTESTED	14
3.5 DESCRIPTION OF SUPPORT UNITS	14
<b>4 . EMC EMISSION TEST</b>	<b>15</b>
4.1 CONDUCTED EMISSION MEASUREMENT	15
4.1.1 POWER LINE CONDUCTED EMISSION LIMITS	15
4.1.2 TEST PROCEDURE	15
4.1.3 DEVIATIONFROMTESTSTANDARD	15
4.1.4 TESTSETUP	16
4.1.5 EUT OPERATING CONDITIONS	16
4.1.6 EUT TEST CONDITIONS	16
4.1.7 TEST RESULTS	16
4.2 RADIATED EMISSION MEASUREMENT	17
4.2.1 RADIATED EMISSION LIMITS	17
4.2.2 TEST PROCEDURE	18
4.2.3 DEVIATIONFROMTESTSTANDARD	18
4.2.4 TESTSETUP	19
4.2.5 EUT OPERATING CONDITIONS	20
4.2.6 EUT TEST CONDITIONS	20
4.2.7 TEST RESULTS (9KHZ TO 30MHZ)	20
4.2.8 TEST RESULTS (30MHZTO 1000 MHZ)	20
4.2.9 TEST RESULTS (ABOVE 1000 MHZ)	20
<b>5 . BANDWIDTH TEST</b>	<b>21</b>
5.1 APPLIED PROCEDURES	21
5.1.1 TEST PROCEDURE	21
5.1.2 DEVIATION FROM STANDARD	21
5.1.3 TEST SETUP	21
5.1.4 EUT OPERATION CONDITIONS	21
5.1.5 EUT TEST CONDITIONS	21
5.1.6 TEST RESULTS	21
<b>6 . MAXIMUM AVG CONDUCTED OUTPUT POWER TEST</b>	<b>22</b>

<b>Table of Contents</b>	<b>Page</b>
<b>6.1 APPLIED PROCEDURES / LIMIT</b>	<b>22</b>
6.1.1 TEST PROCEDURE	22
6.1.2 DEVIATION FROM STANDARD	22
6.1.3 TEST SETUP	22
6.1.4 EUT OPERATION CONDITIONS	22
6.1.5 EUT TEST CONDITIONS	22
6.1.6 TEST RESULTS	22
<b>7 . ANTENNA CONDUCTED SPURIOUS EMISSION</b>	<b>23</b>
7.1 APPLIED PROCEDURES / LIMIT	23
7.1.1 TEST PROCEDURE	23
7.1.2 DEVIATION FROM STANDARD	23
7.1.3 TEST SETUP	23
7.1.4 EUT OPERATION CONDITIONS	23
7.1.5 EUT TEST CONDITIONS	23
7.1.6 TEST RESULTS	23
<b>8 . POWER SPECTRAL DENSITY TEST</b>	<b>24</b>
8.1 APPLIED PROCEDURES / LIMIT	24
8.1.1 TEST PROCEDURE	24
8.1.2 DEVIATION FROM STANDARD	24
8.1.3 TEST SETUP	24
8.1.4 EUT OPERATION CONDITIONS	24
8.1.5 EUT TEST CONDITIONS	24
8.1.6 TEST RESULTS	24
<b>9 . MEASUREMENT INSTRUMENTS LIST</b>	<b>25</b>
<b>10 . EUT TEST PHOTO</b>	<b>27</b>
<b>ATTACHMENT A -CONDUCTED EMISSION</b>	<b>32</b>
<b>ATTACHMENT B -RADIATED EMISSION (9KHZ TO 30MHZ)</b>	<b>37</b>
<b>ATTACHMENT C -RADIATED EMISSION (30MHZ TO 1000MHZ)</b>	<b>46</b>
<b>ATTACHMENT D -RADIATED EMISSION (ABOVE 1000MHZ)</b>	<b>59</b>
<b>ATTACHMENT E - BANDWIDTH</b>	<b>108</b>
<b>ATTACHMENT F- MAXIMUM AVG CONDUCTED OUTPUT POWER</b>	<b>117</b>
<b>ATTACHMENT G - ANTENNA CONDUCTED SPURIOUS EMISSION</b>	<b>121</b>
<b>ATTACHMENT H - POWER SPECTRAL DENSITY</b>	<b>158</b>
<b>11 . EUT PHOTOS</b>	<b>173</b>

### REPORT ISSUED HISTORY

Issued No.	Description	Issued Date
BTL-FCCP-1-1608C193	Original Issue.	Oct. 11, 2016

## 1. CERTIFICATION

Equipment : Wireless AC1200 Dual Band Access Point  
Brand Name : D-Link  
Model Name : DAP-1665  
Applicant : D-Link Corporation  
Date of Test : Aug. 18, 2016 ~ Oct. 10, 2016  
Test Sample : Engineering Sample  
Standard(s) : FCC Part15, Subpart C:(15.247) /ANSI C63.10-2013

The above equipment has been tested and found compliance with the requirement of the relative standards by BTL Inc.

The test data, data evaluation, and equipment configuration contained in our test report (Ref No. BTL-FCCP-1-1608C193) were obtained utilizing the test procedures, test instruments, test sites that has been accredited by the Authority of TAF according to the ISO-17025 quality assessment standard and technical standard(s).

**Test results included in this report is only for the 2.4G WIFI part.**

## 2. SUMMARY OF TEST RESULTS

Test procedures according to the technical standard(s):

Applied Standard(s): FCC Part15 (15.247) , Subpart C				
Standard(s)	Section	Test Item	Judgment	Remark
15.207		Conducted Emission	PASS	
15.247(d)		Antenna conducted Spurious Emission	PASS	
15.247(a)(2)		6dB Bandwidth	PASS	
15.247(b)(3)		Peak Output Power	PASS	
15.247(e)		Power Spectral Density	PASS	
15.203		Antenna Requirement	PASS	
15.209/15.205		Transmitter Radiated Emissions	PASS	

**NOTE:**

(1) "N/A" denotes test is not applicable in this test report.

## 2.1 TEST FACILITY

The test facilities used to collect the test data in this report is at the location of No.3, Jinshagang 1st Road, Shixia, Dalang Town, Dongguan, Guangdong, China.  
 BTL's test firm number for FCC: 319330

## 2.2 MEASUREMENT UNCERTAINTY

Where relevant, the following measurement uncertainty levels have been estimated for tests performed on the EUT as specified in CISPR 16-4-2. The BTL measurement uncertainty is less than the CISPR 16-4-2  $U_{CISPR}$  requirement.

The reported uncertainty of measurement  $y \pm U$ , where expanded uncertainty  $U$  is based on a standard uncertainty multiplied by a coverage factor of  $k=2$ , providing a level of confidence of approximately 95%.

### A. Conducted Measurement:

Test Site	Method	Measurement Frequency Range	U, (dB)
DG-C02	CISPR	150 KHz~30MHz	2.32

### B. Radiated Measurement:

Test Site	Method	Measurement Frequency Range	Ant. H / V	U, (dB)
DG-CB03	CISPR	9KHz~30MHz	V	3.79
		9KHz~30MHz	H	3.57
		30MHz~200MHz	V	3.82
		30MHz~200MHz	H	3.78
		200MHz~ 1,000MHz	V	4.10
		200MHz~ 1,000MHz	H	4.06
		1GHz~18GHz	V	3.12
		1GHz~18GHz	H	3.68
		18GHz~40GHz	V	4.15
		18GHz~40GHz	H	4.14

Note: Unless specifically mentioned, the uncertainty of measurement has not been taken into account to declare the compliance or non-compliance to the specification.

### 3. GENERAL INFORMATION

#### 3.1 GENERAL DESCRIPTION OF EUT

Equipment	Wireless AC1200 Dual Band Access Point	
Brand Name	D-Link	
Model Name	DAP-1665	
Model Difference	N/A	
Product Description	Operation Frequency	2412~2462 MHz
	Modulation Technology	802.11b:DSSS 802.11g:OFDM 802.11n:OFDM
	Bit Rate of Transmitter	802.11b:11/5.5/2/1 Mbps 802.11g: 54/48/36/24/18/12/9/6 Mbps 802.11n up to 300 Mbps
	AVG Output Power (Max.)	802.11b: 20.26dBm 802.11g: 20.42dBm 802.11n(20MHz): 21.10dBm 802.11n(40MHz): 18.57dBm
PowerSource	DC voltage supplied from AC/DC adapter. #1 Brand / Model:D-Link/2AAJ012F US #2 Brand / Model:D-Link /MU12AR120100-A1	
Power Rating	#1 I/P 100-240V~ 50-60Hz, 0.35A O/P: 12.0V --- 1.0A #2 I/P 100-240V~ 50-60Hz, 0.3A O/P: 12V --- 1A	

Note:

1. For a more detailed features description, please refer to the manufacturer's specifications or the user's manual.
2. Channel List:

CH01 – CH11 for 802.11b, 802.11g, 802.11n(20MHz) CH03 – CH09 for 802.11n(40MHz)							
Channel	Frequency (MHz)	Channel	Frequency (MHz)	Channel	Frequency (MHz)	Channel	Frequency (MHz)
01	2412	04	2427	07	2442	10	2457
02	2417	05	2432	08	2447	11	2462
03	2422	06	2437	09	2452		

### 3. Table for Filed Antenna

Group 1

Ant.	Brand	Model Name	Antenna Type	Connector	Gain (dBi)
1	RenFeng	RF21S00240A	Dipole	SMA	5.12
2	RenFeng	RF21S00240A	Dipole	SMA	5.12

Group 2

Ant.	Brand	Model Name	Antenna Type	Connector	Gain (dBi)
1	WHAYU	C037-511429-A	Dipole	SMA	3.50
2	WHAYU	C037-511429-A	Dipole	SMA	3.50

**Note:**

The EUT incorporates a MIMO function. Physically, the EUT provides two completed transmitters and receivers (2T2R). All transmit signals are uncompletely correlated, then, Direction gain = 5.12.

4.

Operating Mode	TX Mode	
	1TX	2TX
802.11b	V (ANT 1)	-
802.11g	V (ANT 1)	-
802.11n(20MHz)	-	V (ANT 1+ ANT 2)
802.11n(40MHz)	-	V (ANT 1+ ANT 2)

### 3.2 DESCRIPTION OF TEST MODES

To investigate the maximum EMI emission characteristics generates from EUT, the test system was pre-scanning tested base on the consideration of following EUT operation mode or test configuration mode which possible have effect on EMI emission level. Each of these EUT operation mode(s) or test configuration mode(s) mentioned above was evaluated respectively.

Pretest Mode	Description
Mode 1	TX B MODE CHANNEL 01/06/11
Mode 2	TX G MODE CHANNEL 01/06/11
Mode 3	TX N-20MHZ MODE CHANNEL 01/06/11
Mode 4	TX N-40MHZ MODE CHANNEL 03/06/09
Mode 5	TX MODE

The EUT system operated these modes were found to be the worst case during the pre-scanning test as following:

<b>For Conducted Test</b>	
Final Test Mode	Description
Mode 5	TX MODE

<b>For Radiated Test</b>	
Final Test Mode	Description
Mode 1	TX B MODE CHANNEL 01/06/11
Mode 2	TX G MODE CHANNEL 01/06/11
Mode 3	TX N-20MHZ MODE CHANNEL 01/06/11
Mode 4	TX N-40MHZ MODE CHANNEL 03/06/09

<b>For Band Edge Test</b>	
Final Test Mode	Description
Mode 1	TX B MODE CHANNEL 01/06/11
Mode 2	TX G MODE CHANNEL 01/06/11
Mode 3	TX N-20MHZ MODE CHANNEL 01/06/11
Mode 4	TX N-40MHZ MODE CHANNEL 03/06/09

<b>6dB Spectrum Bandwidth</b>	
Final Test Mode	Description
Mode 1	TX B MODE CHANNEL 01/06/11
Mode 2	TX G MODE CHANNEL 01/06/11
Mode 3	TX N-20MHZ MODE CHANNEL 01/06/11
Mode 4	TX N-40MHZ MODE CHANNEL 03/06/09

Maximum Conducted Output Power	
Final Test Mode	Description
Mode 1	TX B MODE CHANNEL 01/06/11
Mode 2	TX G MODE CHANNEL 01/06/11
Mode 3	TX N-20MHZ MODE CHANNEL 01/06/11
Mode 4	TX N-40MHZ MODE CHANNEL 03/06/09

Power Spectral Density	
Final Test Mode	Description
Mode 1	TX B MODE CHANNEL 01/06/11
Mode 2	TX G MODE CHANNEL 01/06/11
Mode 3	TX N-20MHZ MODE CHANNEL 01/06/11
Mode 4	TX N-40MHZ MODE CHANNEL 03/06/09

**Note:**

- (1) The measurements are performed at the high, middle, low available channels.
- (2) 802.11b mode: DBPSK (1Mbps)  
 802.11g mode: OFDM (6Mbps)  
 802.11n HT20 mode : BPSK (13Mbps)  
 802.11n HT40mode : BPSK (27Mbps)  
 For radiated emission tests, the highest output powers were set for final test.
- (3) For radiated below 1G test, the 802.11bis found to be the worst case and recorded.
- (4) The EUT was programmed to be in continuously transmitting mode and the transmit duty cycle is not less than 98%.

### 3.3 TABLE OF PARAMETERS OF TEXT SOFTWARE SETTING

During testing, channel & power controlling software provided by the customer was used to control the operating channel as well as the output power level. The RF output power selection is for the setting of RF output power expected by the customer and is going to be fixed on the firmware of the final end product power parameters of WLAN

Test software version	N/A		
Frequency (MHz)	2412	2437	2462
802.11b	57	59	59
802.11g	53	63	52
802.11n (20MHz)	49/48	59/57	53/51
Frequency	2422	2437	2452
802.11n (40MHz)	46/44	53/51	52/50

**3.4 BLOCKDIAGRAMSHOWINGTHECONFIGURATIONOFSYSTEMTESTED**

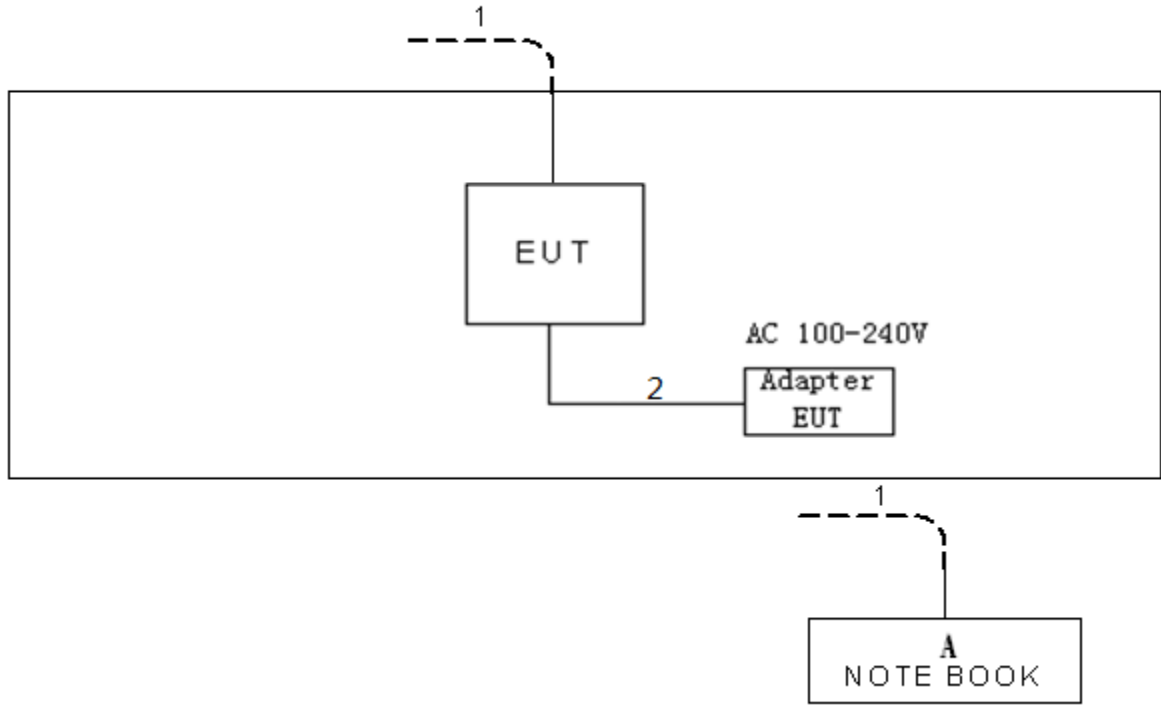

**3.5 DESCRIPTION OF SUPPORT UNITS**

The EUT has been tested as an independent unit together with other necessary accessories or support units. The following support units or accessories were used to form a representative test configuration during the tests.

Item	Equipment	Mfr/Brand	Model/Type No.	FCC ID	Series No.
A	NOTEBOOK	Dell 745	DCSM	DOC	G7K832X

Item	Shielded Type	Ferrite Core	Length	Note
1	NO	NO	10M	RJ-45 Cable
2	NO	NO	1.5M	AC Cable

## 4. EMC EMISSION TEST

### 4.1 CONDUCTED EMISSION MEASUREMENT

#### 4.1.1 POWER LINE CONDUCTED EMISSION LIMITS (Frequency Range 150KHz-30MHz)

Frequency of Emission (MHz)	Conducted Limit (dB $\mu$ V)	
	Quasi-peak	Average
0.15 -0.50	66 to 56*	56 to 46*
0.50 -5.0	56	46
5.0 -30.0	60	50

Note:

- (1) The limit of " \* " decreases with the logarithm of the frequency
- (2) The test result calculated as following:  
 Measurement Value = Reading Level + Correct Factor  
 Correct Factor = Insertion Loss + Cable Loss + Attenuator Factor(if use)  
 Margin Level = Measurement Value - Limit Value

The following table is the setting of the receiver

Receiver Parameters	Setting
Attenuation	10 dB
Start Frequency	0.15 MHz
Stop Frequency	30 MHz
IF Bandwidth	9 KHz

#### 4.1.2 TEST PROCEDURE

- a. The EUT was placed 0.8 meters from the horizontal ground plane with EUT being connected to the power mains through a line impedance stabilization network (LISN). All other support equipments powered from additional LISN(s). The LISN provide 50 Ohm/ 50uH of coupling impedance for the measuring instrument.
- b. Interconnecting cables that hang closer than 40 cm to the groundplane shall be folded back and forth in the center forming a bundle 30 to 40 cm long.
- c. I/O cables that are not connected to a peripheral shall be bundled in the center. The end of the cable may be terminated, if required, using the correct terminating impedance. The overall length shall not exceed 1 m.
- d. LISN at least 80 cm from nearest part of EUT chassis.
- e. For the actual test configuration, please refer to the related Item –EUT Test Photos.

#### 4.1.3 DEVIATIONFROMTESTSTANDARD

No deviation

**4.1.4 TESTSETUP**

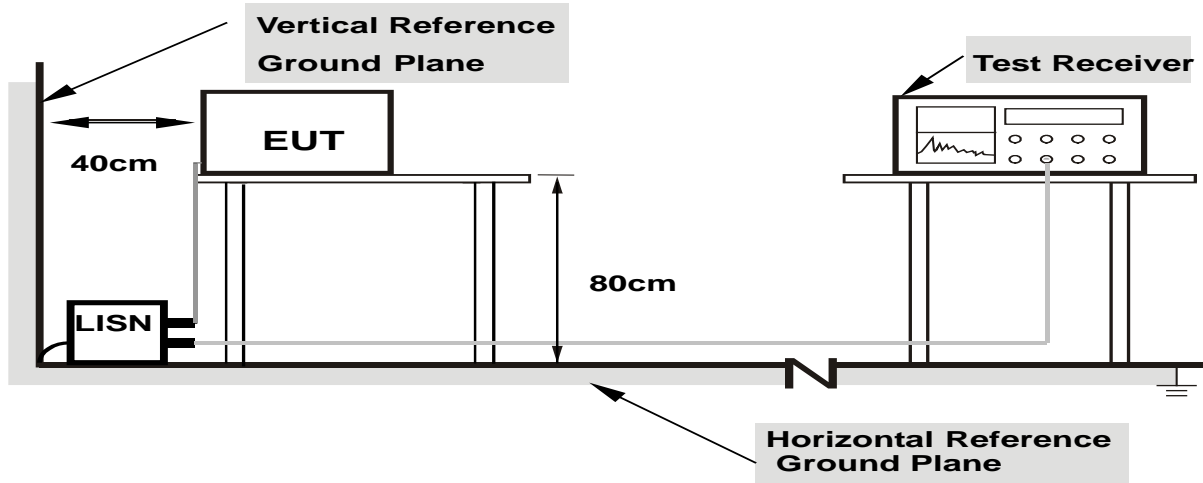

- Note:**
- 1.Support units were connected to second LISN.
  - 2.Both of LISNs (AMN) are 80 cm from EUT and at least 80 from other units and other metal planes

**4.1.5 EUT OPERATING CONDITIONS**

The EUT was placed on the test table and programmed in normal function.

**4.1.6 EUT TEST CONDITIONS**

Temperature: 25°C Relative Humidity: 55% Test Voltage: AC 120V/60Hz

**4.1.7 TEST RESULTS**

Please refer to the Attachment A.

## 4.2 RADIATED EMISSION MEASUREMENT

### 4.2.1 RADIATED EMISSION LIMITS

In case the emission fall within the restricted band specified on 15.205(a), then the 15.209(a) limit in the table below has to be followed.

#### LIMITS OF RADIATED EMISSION MEASUREMENT (9KHz-1000MHz)

Frequency (MHz)	Field Strength (microvolts/meter)	Measurement Distance (meters)
0.009~0.490	2400/F(KHz)	300
0.490~1.705	24000/F(KHz)	30
1.705~30.0	30	30
30~88	100	3
88~216	150	3
216~960	200	3
960~1000	500	3

#### LIMITS OF RADIATED EMISSION MEASUREMENT (Above 1000MHz)

Frequency (MHz)	(dBuV/m) (at 3 meters)	
	PEAK	AVERAGE
Above 1000	74	54

Notes:

- (1) The limit for radiated test was performed according to FCC PART 15C.
- (2) The tighter limit applies at the band edges.
- (3) Emission level (dBuV/m)=20log Emission level (uV/m).
- (4) The test result calculated as following:  
 Measurement Value = Reading Level + Correct Factor  
 Correct Factor = Antenna Factor + Cable Loss - Amplifier Gain(if use)  
 Margin Level = Measurement Value - Limit Value

Spectrum Parameter	Setting
Attenuation	Auto
Start Frequency	1000 MHz
Stop Frequency	10th carrier harmonic
RBW / VBW (Emission in restricted band)	1MHz / 3MHz for Peak, 1MHz / 1/T for Average

Receiver Parameter	Setting
Attenuation	Auto
Start ~ Stop Frequency	9KHz~90KHz for PK/AVG detector
Start ~ Stop Frequency	90KHz~110KHz for QP detector
Start ~ Stop Frequency	110KHz~490KHz for PK/AVG detector
Start ~ Stop Frequency	490KHz~30MHz for QP detector
Start ~ Stop Frequency	30MHz~1000MHz for QP detector

**4.2.2 TEST PROCEDURE**

- a. The measuring distance of 3 m shall be used for measurements. The EUT was placed on the top of a rotating table 0.8 meter above the ground at a 3 meter semi-anechoic chamber. The table was rotated 360 degrees to determine the position of the highest radiation.(below 1GHz)
- b. The measuring distance of 3 m shall be used for measurements. The EUT was placed on the top of a rotating table 1.5 meter above the ground at a 3 meter semi-anechoic chamber. The table was rotated 360 degrees to determine the position of the highest radiation.(above 1GHz)
- c. The height of the equipment or of the substitution antenna shall be 0.8m or 1.5m; the height of the test antenna shall vary between 1 m to 4 m. Both horizontal and vertical polarizations of the antenna are set to make the measurement.
- d. For each suspected emission, the EUT was arranged to its worst case and then the antenna was tuned to heights find the maximum reading (used Bore sight function).
- e. The receiver system was set to peak and average detect function and specified bandwidth with maximum hold mode when the test frequency is above 1GHz.
- f. The initial step in collecting radiated emission data is a receiver peak detector mode pre-scanning the measurement frequency range. Significant peaks are then marked and then Quasi Peak detector mode re-measured.
- g. All readings are Peak unless otherwise stated QP in column of Note. Peak denotes that the Peak reading compliance with the QP Limits and then QP Mode measurement didn't perform. (below 1GHz)
- h. All readings are Peak Mode value unless otherwise stated AVG in column of Note. If the Peak Mode Measured value compliance with the Peak Limits and lower than AVG Limits, the EUT shall be deemed to meet both Peak & AVG Limits and then only Peak Mode was measured, but AVG Mode didn't perform. (above 1GHz)
- i. For the actual test configuration, please refer to the related Item –EUT Test Photos.

**4.2.3 DEVIATIONFROMTESTSTANDARD**

No deviation

**4.2.4 TESTSETUP**

(A) Radiated Emission Test Set-Up Frequency Below 1 GHz

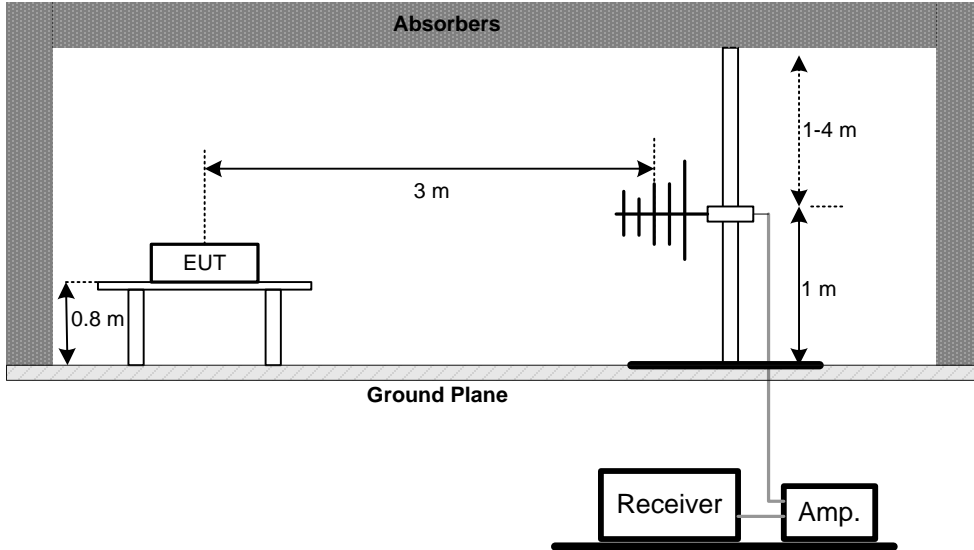

(B) Radiated Emission Test Set-Up Frequency Above 1 GHz

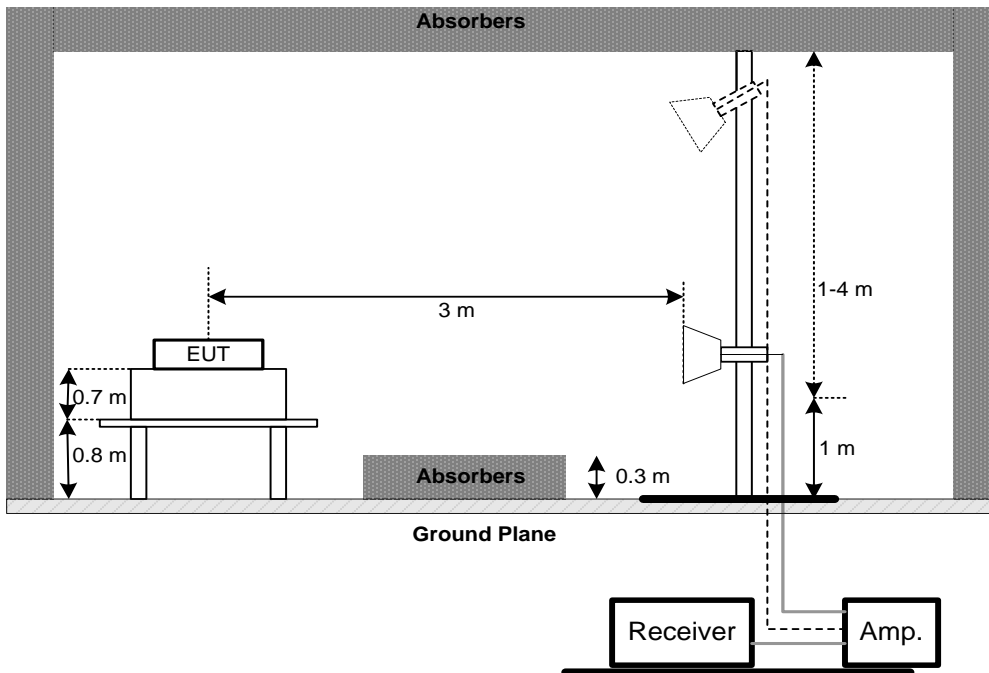

(C) For Radiated Emissions Below 30MHz

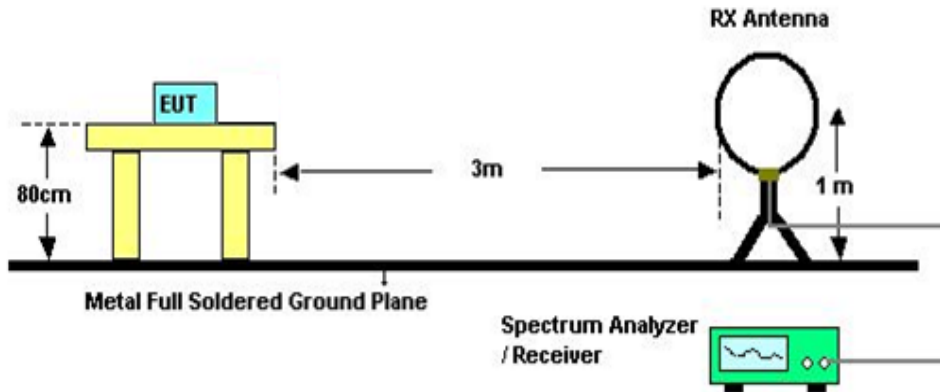

**4.2.5 EUT OPERATING CONDITIONS**

The EUT was programmed to be in continuously transmitting mode.

**4.2.6 EUT TEST CONDITIONS**

Temperature: 25°C Relative Humidity: 55% Test Voltage: AC 120V/60Hz

**4.2.7 TEST RESULTS (9KHZ TO 30MHZ)**

Please refer to the Attachment B

Remark:

- (1) The amplitude of spurious emissions which are attenuated by more than 20 dB below the permissible value has no need to be reported.
- (2) Distance extrapolation factor =  $40 \log(\text{specific distance} / \text{test distance})$  (dB).
- (3) Limit line = specific limits (dBuV) + distance extrapolation factor.

**4.2.8 TEST RESULTS (30MHZ TO 1000 MHZ)**

Please refer to the Attachment C.

**4.2.9 TEST RESULTS (ABOVE 1000 MHZ)**

Please refer to the Attachment D.

Remark:

- (1) No limit: This is fundamental signal, the judgment is not applicable. For fundamental signal judgment was referred to Peak output test.

**5. BANDWIDTH TEST**

**5.1 APPLIED PROCEDURES**

FCC Part15 (15.247) , Subpart C			
Section	Test Item	Frequency Range (MHz)	Result
15.247(a)(2)	Bandwidth	2400-2483.5	PASS

**5.1.1 TEST PROCEDURE**

- a. The EUT was directly connected to the spectrum analyzer and antenna output port as show in the block diagram below,
- b. Spectrum Setting: RBW= 100KHz, VBW=300KHz, Sweep time = 2.5 ms.

**5.1.2 DEVIATION FROM STANDARD**

No deviation.

**5.1.3 TEST SETUP**

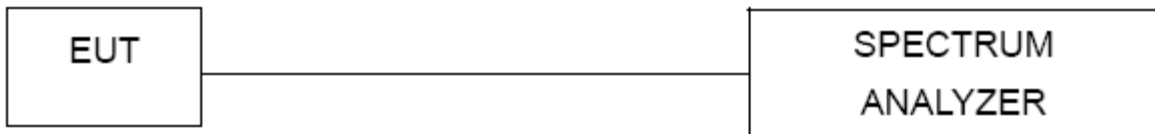

**5.1.4 EUT OPERATION CONDITIONS**

The EUT was programmed to be in continuously transmitting mode.

**5.1.5 EUT TEST CONDITIONS**

Temperature: 25°C Relative Humidity: 55% Test Voltage: AC 120V/60Hz

**5.1.6 TEST RESULTS**

Please refer to the Attachment E.

**6. MAXIMUM AVG CONDUCTED OUTPUT POWER TEST**

**6.1 APPLIED PROCEDURES / LIMIT**

FCC Part15 (15.247) , Subpart C				
Section	Test Item	Limit	Frequency Range (MHz)	Result
15.247(b)(3)	Maximum Output Power	1 Watt or 30dBm	2400-2483.5	PASS

**6.1.1 TEST PROCEDURE**

- a. The EUT was directly connected to the power meter and antenna output port as show in the block diagram below,
- b. The maximum peak conducted output power was performed in accordance with method 9.1.2 of FCC KDB 558074D01 DTS Meas Guidance and FCC KDB 662911 D01 Multiple Transmitter Output.

**6.1.2 DEVIATION FROM STANDARD**

No deviation.

**6.1.3 TEST SETUP**



**6.1.4 EUT OPERATION CONDITIONS**

The EUT was programmed to be in continuously transmitting mode.

**6.1.5 EUT TEST CONDITIONS**

Temperature: 25°C Relative Humidity: 55% Test Voltage: AC 120V/60Hz

**6.1.6 TEST RESULTS**

Please refer to the Attachment F.

**7. ANTENNA CONDUCTED SPURIOUS EMISSION**

**7.1 APPLIED PROCEDURES / LIMIT**

In any 100 kHz bandwidth outside the frequency band in which the spread spectrum ordigitally modulated device is operating, the RF power that is produced shall be at least 20 dB below that in the 100 kHz bandwidth within the band thatcontains the highest level of the desired power, based on either an RF conducted or a radiated measurement, provided that the transmitter demonstrates compliance with the peak conducted power limits.

**7.1.1 TEST PROCEDURE**

- a. The EUT was directly connected to the spectrum analyzer and antenna output port as show in the block diagram below,
- b. Spectrum Setting: RBW= 100KHz, VBW=300KHz, Sweep time = Auto.
- c. Offset=antenna gain+cable loss

**7.1.2 DEVIATION FROM STANDARD**

No deviation.

**7.1.3 TEST SETUP**



**7.1.4 EUT OPERATION CONDITIONS**

The EUT was programmed to be in continuously transmitting mode.

**7.1.5 EUT TEST CONDITIONS**

Temperature: 25°C    Relative Humidity: 55%Test Voltage: AC 120V/60Hz

**7.1.6 TEST RESULTS**

Please refer to the Attachment G.

## 8. POWER SPECTRAL DENSITY TEST

### 8.1 APPLIED PROCEDURES / LIMIT

FCC Part15 (15.247) , Subpart C				
Section	Test Item	Limit	Frequency Range (MHz)	Result
15.247(e)	Power Spectral Density	8 dBm (in any 3KHz)	2400-2483.5	PASS

#### 8.1.1 TEST PROCEDURE

- a. The EUT was directly connected to the spectrum analyzer and antenna output port as show in the block diagram below,
- b. Spectrum Setting: RBW=3KHz, VBW=10KHz, Sweep time = Auto.

#### 8.1.2 DEVIATION FROM STANDARD

No deviation.

#### 8.1.3 TEST SETUP

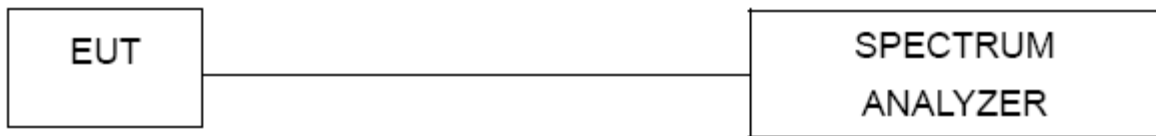

#### 8.1.4 EUT OPERATION CONDITIONS

The EUT was programmed to be in continuously transmitting mode.

#### 8.1.5 EUT TEST CONDITIONS

Temperature: 25°C    Relative Humidity: 55% Test Voltage: AC 120V/60Hz

#### 8.1.6 TEST RESULTS

Please refer to the Attachment H.

## 9. MEASUREMENT INSTRUMENTS LIST

Conducted Emission Measurement					
Item	Kind of Equipment	Manufacturer	Type No.	Serial No.	Calibrated until
1	LISN	EMCO	3816/2	0052765	Mar. 27, 2017
2	LISN	R&S	ENV216	101447	Mar. 27, 2017
3	Test Cable	emci	RG223(9KHz-30MHz)	C_17	Mar. 10, 2017
4	EMI Test Receiver	R&S	ESCI	100382	Mar. 27, 2017
5	50Ω Terminator	SHX	TF2-3G-A	08122901	Mar. 27, 2017
6	Measurement Software	Farad	EZ-EMC Ver.NB-03A1-01	N/A	N/A

Radiated Emission Measurement					
Item	Kind of Equipment	Manufacturer	Type No.	Serial No.	Calibrated until
1	Antenna	Schwarzbeck	VULB9160	9160-3232	Mar. 27, 2017
2	Amplifier	HP	8447D	2944A09673	Nov. 09, 2016
3	Receiver	AGILENT	N9038A	MY52130039	Oct. 10, 2017
4	Test Cable	emci	LMR-400(30MHz-1GHz)	C-01	Jun. 26, 2017
5	Control	CT	SC100	N/A	N/A
6	Position Control	MF	MF-7802	MF780208416	N/A
7	Antenna	ETS	3115	00075789	Mar. 27, 2017
8	Amplifier	Agilent	8449B	3008A02274	Nov. 01, 2016
9	Receiver	AGILENT	N9038A	MY52130039	Oct. 11, 2016
10	Test Cable	emci	EMC104-SM-SM-10000(1GHz-26.5GHz)	C-68	Jun. 26, 2017
11	Controller	CT	SC100	N/A	N/A
12	Broad-Band Horn Antenna	Schwarzbeck	BBHA 9170	9170319	Apr. 23, 2017
13	Microwave Pre-amplifier With Adaptor	EMC INSTRUMENT	EMC2654045	980039 & HA01	Mar. 27, 2017
14	Active Loop Antenna	R&S	HFH2-Z2	830749/020	Sep. 06, 2017
15	Measurement Software	Farad	EZ-EMC Ver.NB-03A1-01	N/A	N/A

6dB Bandwidth Measurement					
Item	Kind of Equipment	Manufacturer	Type No.	Serial No.	Calibrated until
1	Spectrum Analyzer	R&S	FSP 40	100185	Oct. 11, 2016

Peak Output Power Measurement					
Item	Kind of Equipment	Manufacturer	Type No.	Serial No.	Calibrated until
1	P-series Power meter	Agilent	N1911A	MY45100473	Oct. 26, 2016
2	Wireband Power sensor	Agilent	N1921A	MY51100041	Oct. 26, 2016

Antenna Conducted Spurious Emission Measurement					
Item	Kind of Equipment	Manufacturer	Type No.	Serial No.	Calibrated until
1	Spectrum Analyzer	R&S	FSP 40	100185	Oct. 11, 2016

Power Spectral Density Measurement					
Item	Kind of Equipment	Manufacturer	Type No.	Serial No.	Calibrated until
1	Spectrum Analyzer	R&S	FSP 40	100185	Oct. 11, 2016

Remark: "N/A" denotes no model name, serial no. or calibration specified.  
 All calibration period of equipment list is one year.

**10. EUT TEST PHOTO**

**Conducted Measurement Photos**



**Radiated Measurement Photos**

**9KHz to 30MHz**



**Radiated Measurement Photos**

**30MHz to 1000MHz**

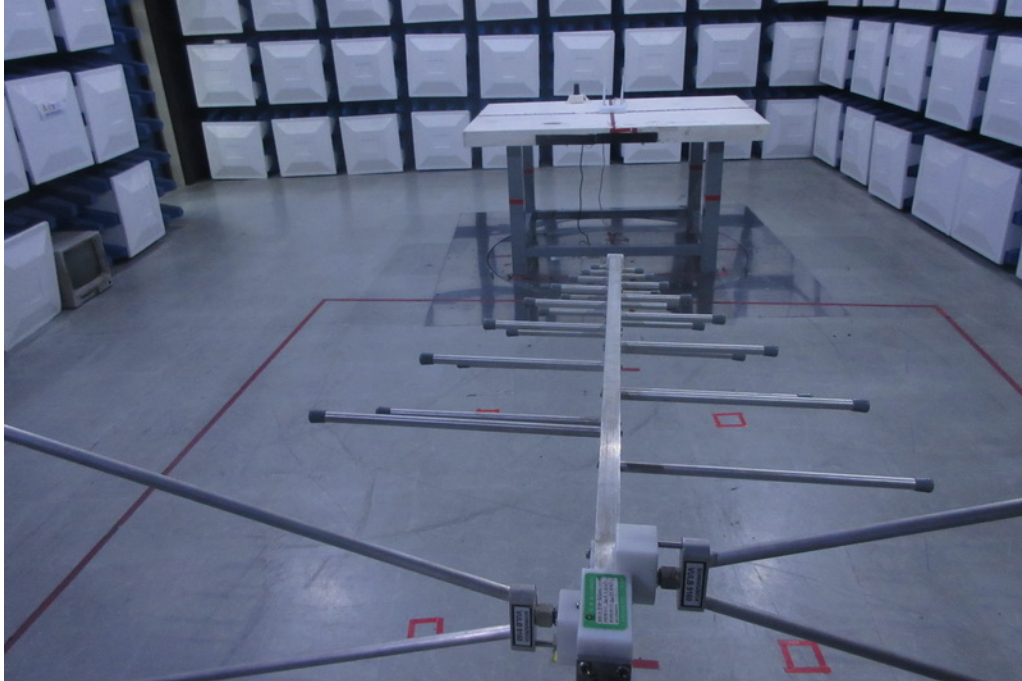

**Radiated Measurement Photos**

**Above 1000MHz**

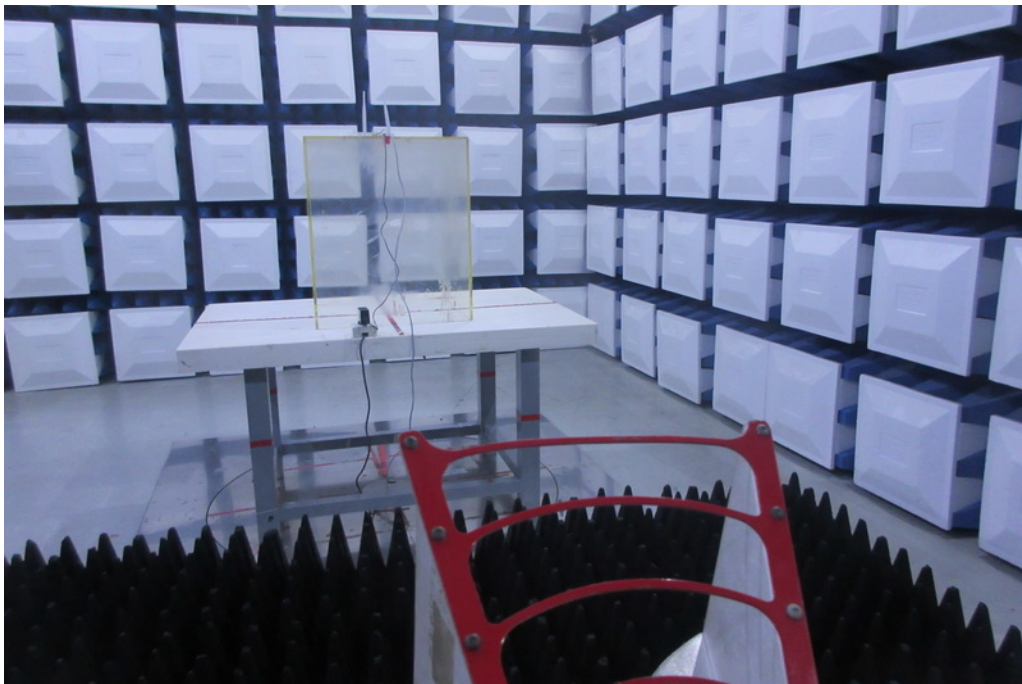
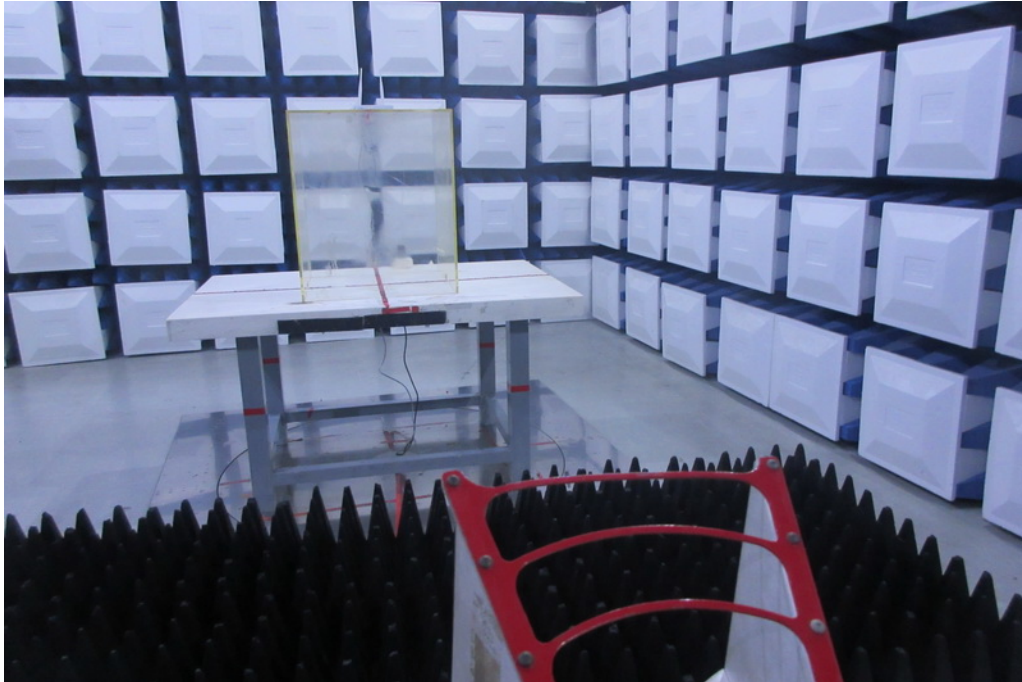

**Conducted Measurement Photos**

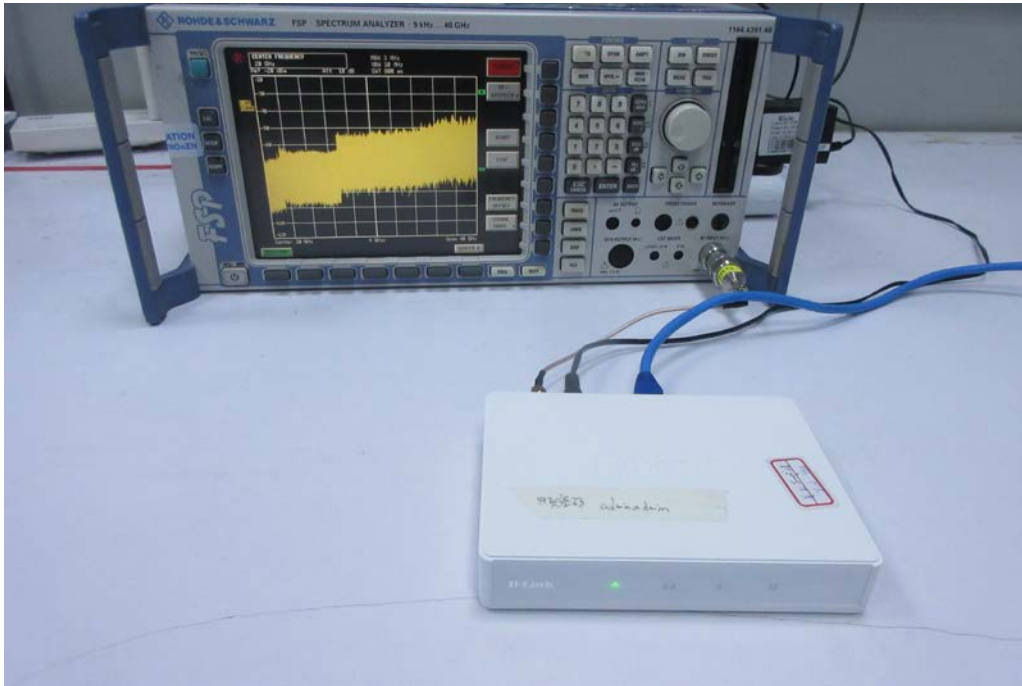

# ATTACHMENT A -CONDUCTED EMISSION

Test Mode : TX MODE\_Adapter: 2AAJ012F US

**Line**

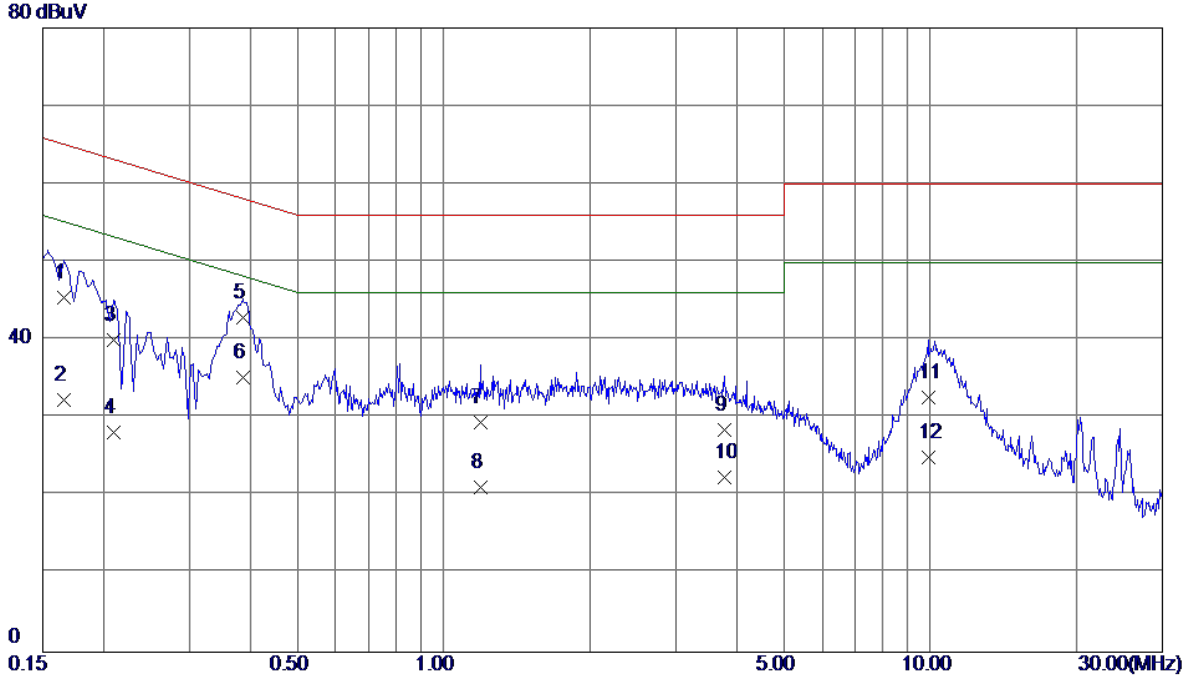

No.	Freq. MHz	Reading Level dBuV	Correct Factor dB	Measure ment dBuV	Limit dBuV	Margin dB	Detector	Comment
1	0.1660	35.90	9.52	45.42	65.16	-19.74	QP	
2	0.1660	22.80	9.52	32.32	55.16	-22.84	AVG	
3	0.2100	30.40	9.53	39.93	63.21	-23.28	QP	
4	0.2100	18.60	9.53	28.13	53.21	-25.08	AVG	
5	0.3860	33.30	9.54	42.84	58.15	-15.31	QP	
6 *	0.3860	25.60	9.54	35.14	48.15	-13.01	AVG	
7	1.1900	19.70	9.77	29.47	56.00	-26.53	QP	
8	1.1900	11.40	9.77	21.17	46.00	-24.83	AVG	
9	3.7780	18.30	10.17	28.47	56.00	-27.53	QP	
10	3.7780	12.30	10.17	22.47	46.00	-23.53	AVG	
11	9.9100	22.50	10.21	32.71	60.00	-27.29	QP	
12	9.9100	14.70	10.21	24.91	50.00	-25.09	AVG	

Test Mode : TX MODE\_Adapter: 2AAJ012F US

Neutral

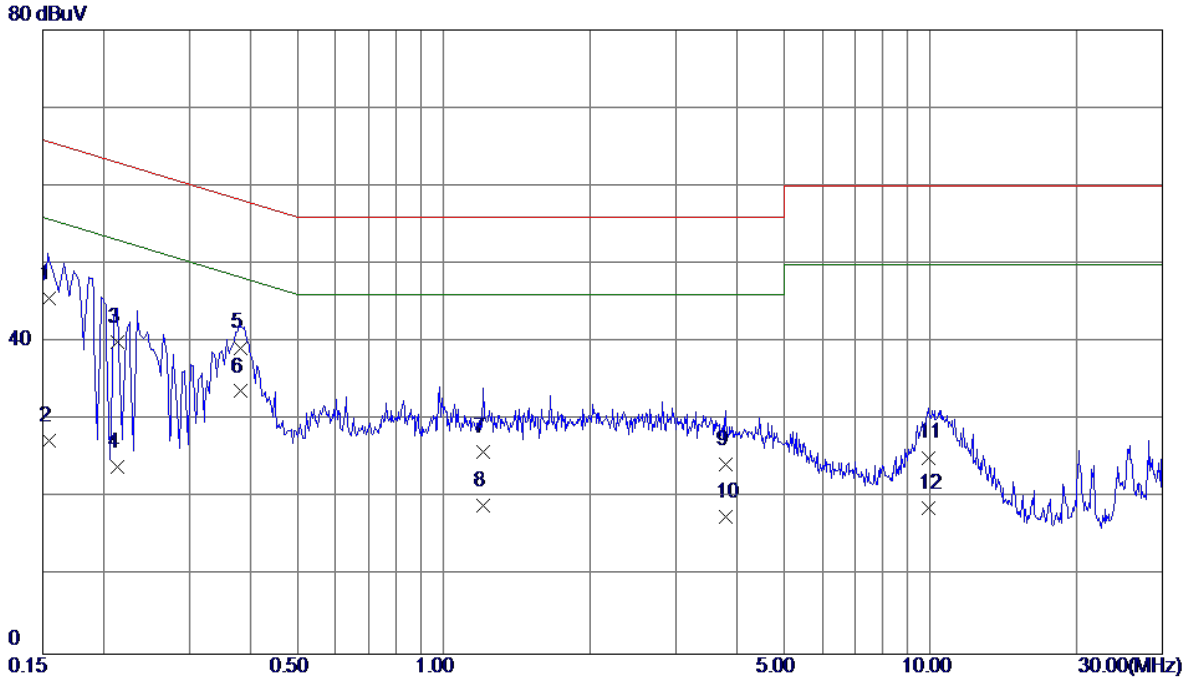

No.	Freq. MHz	Reading Level dBuV	Correct Factor dB	Measurement dBuV	Limit dBuV	Margin dB	Detector	Comment
1	0.1548	36.10	9.50	45.60	65.74	-20.14	QP	
2	0.1548	17.90	9.50	27.40	55.74	-28.34	AVG	
3	0.2140	30.40	9.53	39.93	63.05	-23.12	QP	
4	0.2140	14.50	9.53	24.03	53.05	-29.02	AVG	
5	0.3820	29.81	9.47	39.28	58.24	-18.96	QP	
6 *	0.3820	24.21	9.47	33.68	48.24	-14.56	AVG	
7	1.2059	16.30	9.67	25.97	56.00	-30.03	QP	
8	1.2059	9.40	9.67	19.07	46.00	-26.93	AVG	
9	3.7900	14.50	9.87	24.37	56.00	-31.63	QP	
10	3.7900	7.80	9.87	17.67	46.00	-28.33	AVG	
11	9.9100	14.90	10.30	25.20	60.00	-34.80	QP	
12	9.9100	8.40	10.30	18.70	50.00	-31.30	AVG	

Test Mode : TX MODE \_ Adapter:MU12AR120100-A1

### Line

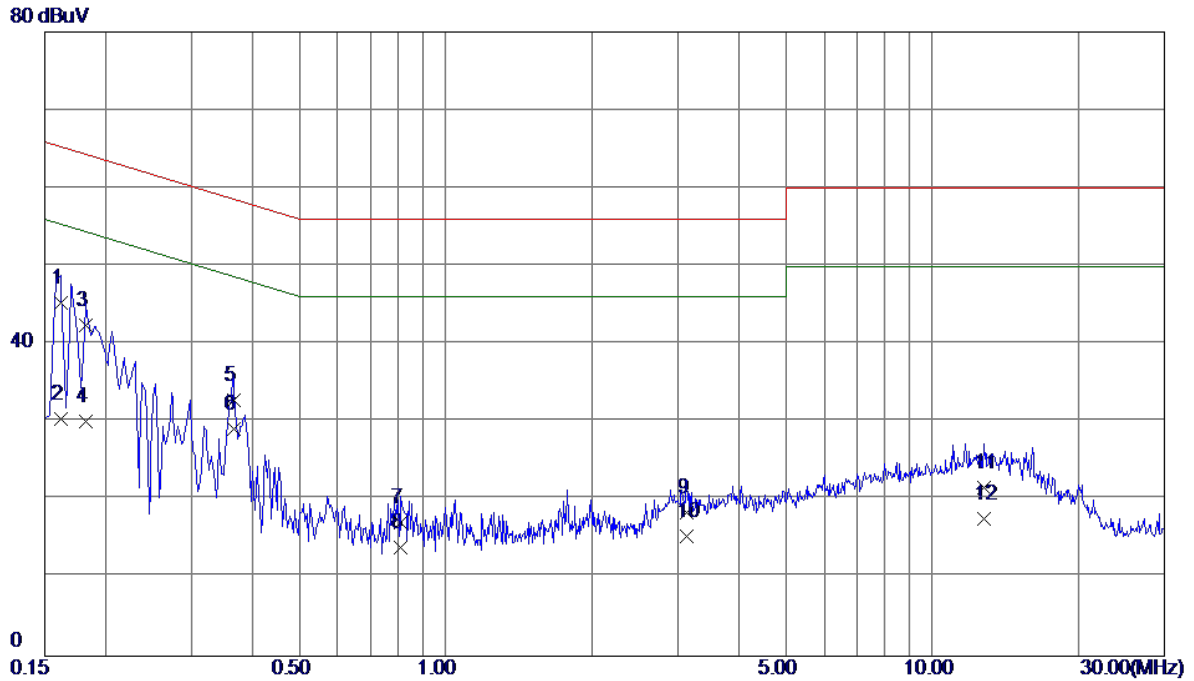

No.	Freq. MHz	Reading Level dBuV	Correct Factor dB	Measure ment dBuV	Limit dBuV	Margin dB	Detector	Comment
1	0.1620	35.70	9.52	45.22	65.36	-20.14	QP	
2	0.1620	20.90	9.52	30.42	55.36	-24.94	AVG	
3	0.1819	32.90	9.53	42.43	64.40	-21.97	QP	
4	0.1819	20.60	9.53	30.13	54.40	-24.27	AVG	
5	0.3660	23.30	9.54	32.84	58.59	-25.75	QP	
6 *	0.3660	19.60	9.54	29.14	48.59	-19.45	AVG	
7	0.8100	7.36	9.75	17.11	56.00	-38.89	QP	
8	0.8100	4.23	9.75	13.98	46.00	-32.02	AVG	
9	3.1340	8.25	10.10	18.35	56.00	-37.65	QP	
10	3.1340	5.23	10.10	15.33	46.00	-30.67	AVG	
11	12.7580	11.26	10.29	21.55	60.00	-38.45	QP	
12	12.7580	7.37	10.29	17.66	50.00	-32.34	AVG	

Test Mode : TX MODE \_ Adapter:MU12AR120100-A1

**Neutral**

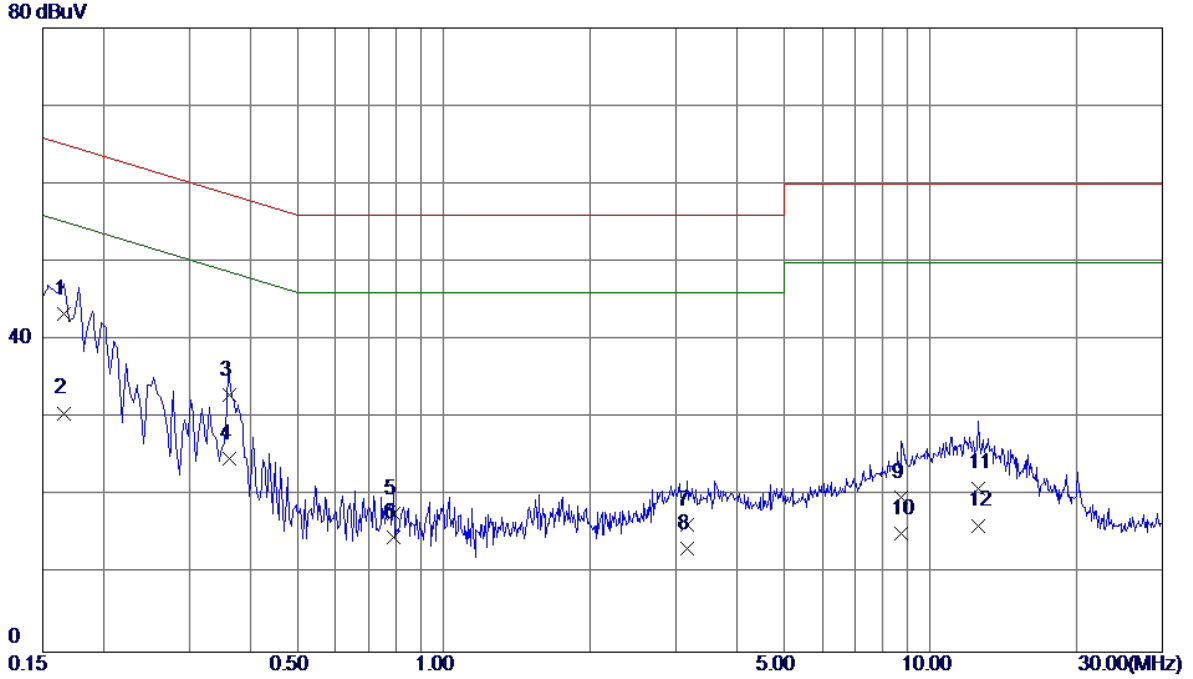

No.	Freq. MHz	Reading Level dBuV	Correct Factor dB	Measure ment dBuV	Limit dBuV	Margin dB	Detector	Comment
1 *	0.1660	33.90	9.44	43.34	65.16	-21.82	QP	
2	0.1660	21.20	9.44	30.64	55.16	-24.52	AVG	
3	0.3620	23.51	9.51	33.02	58.68	-25.66	QP	
4	0.3620	15.31	9.51	24.82	48.68	-23.86	AVG	
5	0.7900	8.25	9.54	17.79	56.00	-38.21	QP	
6	0.7900	5.23	9.54	14.77	46.00	-31.23	AVG	
7	3.1619	6.50	9.81	16.31	56.00	-39.69	QP	
8	3.1619	3.50	9.81	13.31	46.00	-32.69	AVG	
9	8.7299	9.70	10.16	19.86	60.00	-40.14	QP	
10	8.7299	5.00	10.16	15.16	50.00	-34.84	AVG	
11	12.5420	10.70	10.34	21.04	60.00	-38.96	QP	
12	12.5420	5.90	10.34	16.24	50.00	-33.76	AVG	

**ATTACHMENT B -RADIATED EMISSION (9KHZ TO 30MHZ)**

Test Mode: TX B MODE CHANNEL 01\_Adapter: 2AAJ012F US

Ant 0°

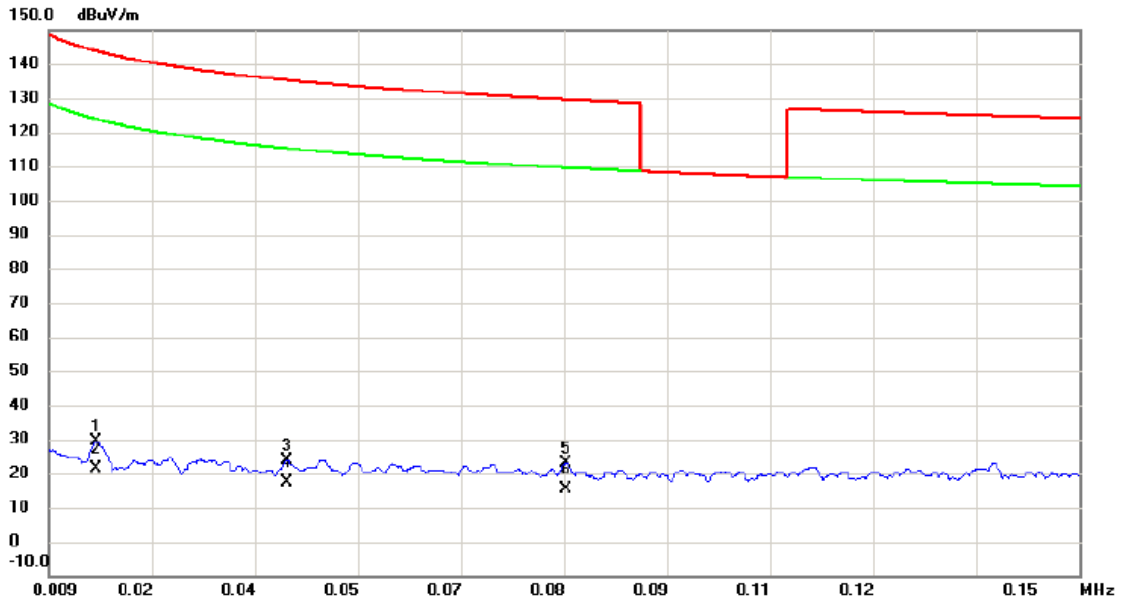

No.	Mk.	Freq. MHz	Reading Level dBuV	Correct Factor dB	Measure- ment dBuV/m	Limit dBuV/m	Margin dB	Detector	Comment
1		0.0155	5.54	23.79	29.33	143.80	-114.47	peak	
2		0.0155	-2.49	23.79	21.30	123.80	-102.50	AVG	
3		0.0417	3.00	20.84	23.84	135.20	-111.36	peak	
4		0.0417	-3.42	20.84	17.42	115.20	-97.78	AVG	
5		0.0798	3.77	19.32	23.09	129.56	-106.47	peak	
6	*	0.0798	-3.72	19.32	15.60	109.56	-93.96	AVG	

Test Mode: TX B MODE CHANNEL 01\_Adapter: 2AAJ012F US

Ant 0°

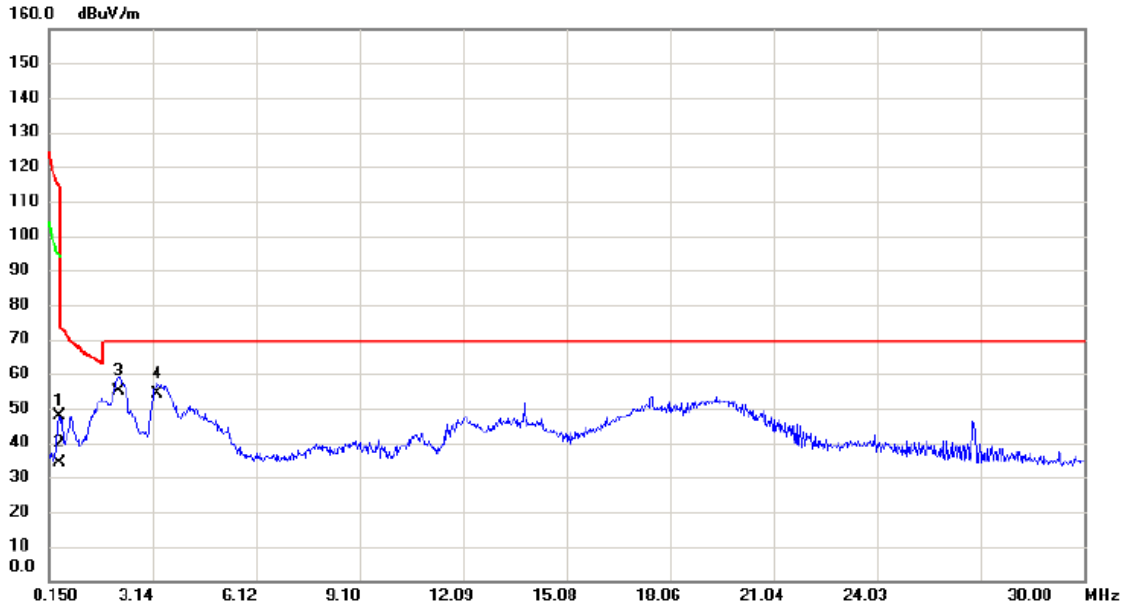

No.	Mk.	Freq. MHz	Reading Level dBuV	Correct Factor dB	Measure- ment dBuV/m	Limit dBuV/m	Margin dB	Detector	Comment
1		0.4485	29.48	18.43	47.91	114.57	-66.66	peak	
2		0.4485	15.65	18.43	34.08	94.57	-60.49	AVG	
3	*	2.1500	37.16	17.72	54.88	69.54	-14.66	QP	
4		3.2544	36.93	17.17	54.10	69.54	-15.44	QP	

Test Mode: TX B MODE CHANNEL 01\_Adapter: 2AAJ012F US

Ant 90°

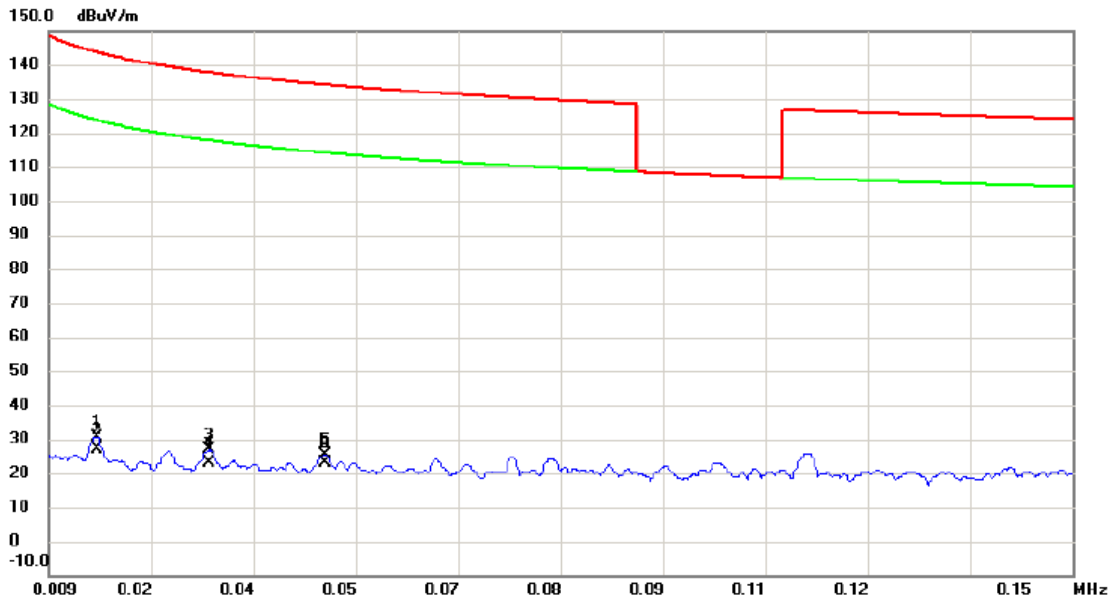

No.	Mk.	Freq. MHz	Reading Level dBuV	Correct Factor dB	Measure- ment dBuV/m	Limit dBuV/m	Margin dB	Detector	Comment
1		0.0156	6.96	23.78	30.74	143.74	-113.00	peak	
2		0.0156	3.25	23.78	27.03	123.74	-96.71	AVG	
3		0.0310	4.69	22.16	26.85	137.78	-110.93	peak	
4		0.0310	0.77	22.16	22.93	117.78	-94.85	AVG	
5		0.0471	5.41	20.18	25.59	134.14	-108.55	peak	
6	*	0.0471	2.72	20.18	22.90	114.14	-91.24	AVG	

Test Mode: TX B MODE CHANNEL 01\_Adapter: 2AAJ012F US

Ant 90°

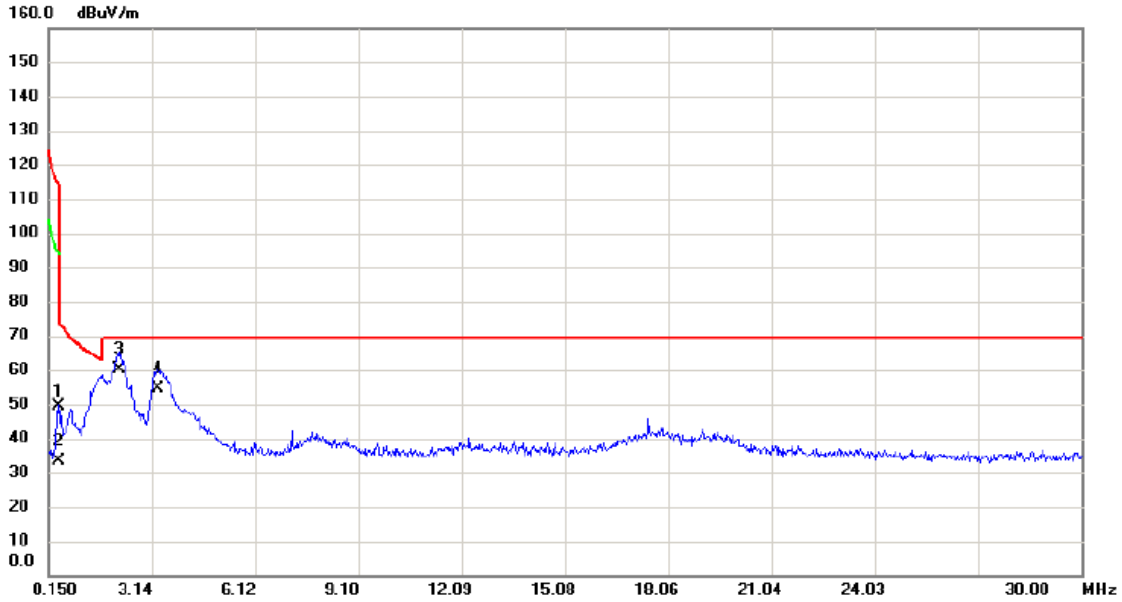

No.	Mk.	Freq. MHz	Reading Level dBuV	Correct Factor dB	Measure- ment dBuV/m	Limit dBuV/m	Margin dB	Detector	Comment
1		0.4485	31.17	18.43	49.60	114.57	-64.97	peak	
2		0.4485	14.95	18.43	33.38	94.57	-61.19	AVG	
3	*	2.1798	42.42	17.68	60.10	69.54	-9.44	QP	
4		3.3141	37.15	17.30	54.45	69.54	-15.09	QP	

Test Mode: TX B MODE CHANNEL 01\_ Adapter:MU12AR120100-A1

Ant 0°

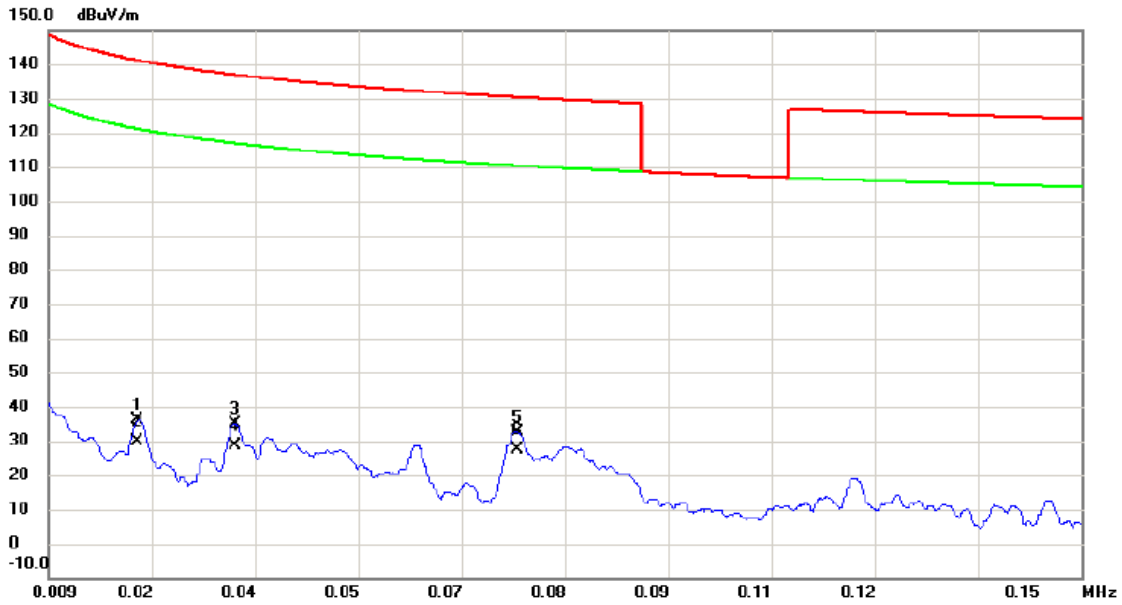

No.	Mk.	Freq. MHz	Reading Level dBuV	Correct Factor dB	Measure- ment dBuV/m	Limit dBuV/m	Margin dB	Detector	Comment
1		0.0212	12.73	23.37	36.10	141.08	-104.98	peak	
2		0.0212	6.43	23.37	29.80	121.08	-91.28	AVG	
3		0.0345	13.43	21.73	35.16	136.85	-101.69	peak	
4		0.0345	6.73	21.73	28.46	116.85	-88.39	AVG	
5		0.0730	12.97	19.55	32.52	130.34	-97.82	peak	
6	*	0.0730	7.79	19.55	27.34	110.34	-83.00	AVG	

Test Mode: TX B MODE CHANNEL 01\_ Adapter:MU12AR120100-A1

Ant 0°

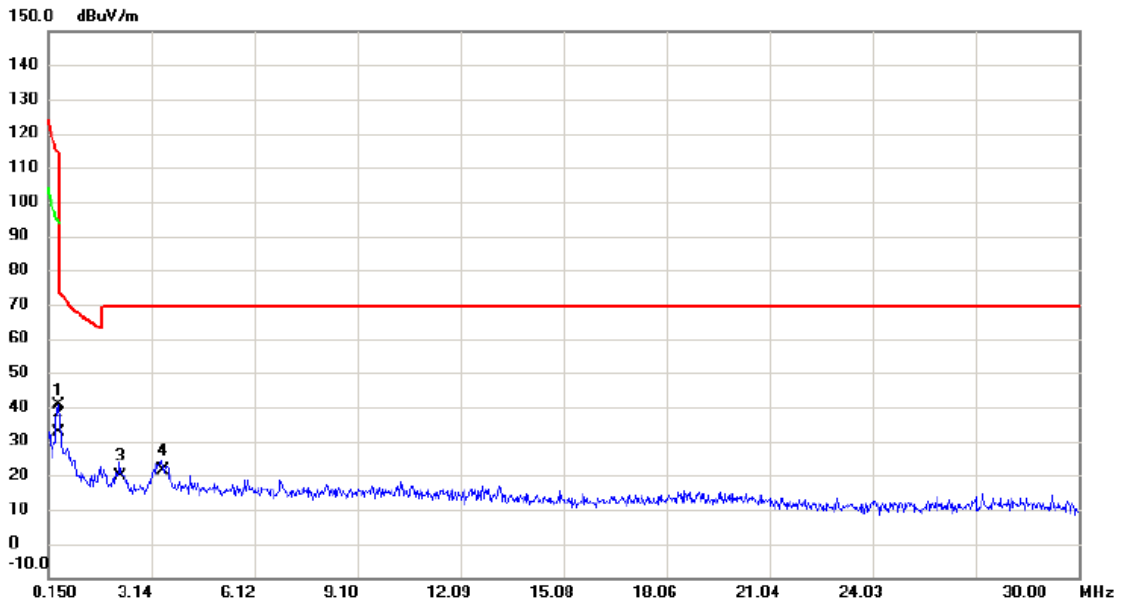

No.	Mk.	Freq. MHz	Reading Level dBuV	Correct Factor dB	Measure- ment dBuV/m	Limit dBuV/m	Margin dB	Detector	Comment
1		0.4633	22.35	18.41	40.76	114.29	-73.53	peak	
2		0.4633	14.36	18.41	32.77	94.29	-61.52	AVG	
3		2.2244	2.23	17.62	19.85	69.54	-49.69	QP	
4	*	3.4632	3.78	17.61	21.39	69.54	-48.15	QP	

Test Mode: TX B MODE CHANNEL 01\_ Adapter:MU12AR120100-A1

Ant 90°

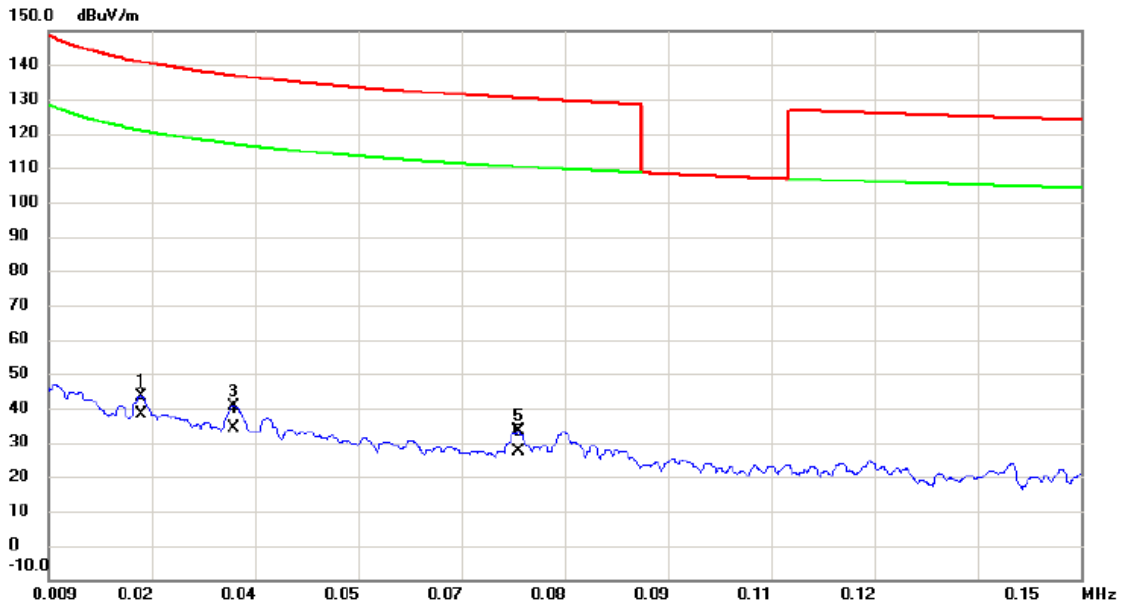

No.	Mk.	Freq. MHz	Reading Level dBuV	Correct Factor dB	Measure- ment dBuV/m	Limit dBuV/m	Margin dB	Detector	Comment
1		0.0217	20.29	23.31	43.60	140.88	-97.28	peak	
2	*	0.0217	14.83	23.31	38.14	120.88	-82.74	AVG	
3		0.0343	18.72	21.76	40.48	136.90	-96.42	peak	
4		0.0343	12.40	21.76	34.16	116.90	-82.74	AVG	
5		0.0732	13.67	19.55	33.22	130.31	-97.09	peak	
6		0.0732	7.71	19.55	27.26	110.31	-83.05	AVG	

Test Mode: TX B MODE CHANNEL 01\_ Adapter:MU12AR120100-A1

Ant 90°

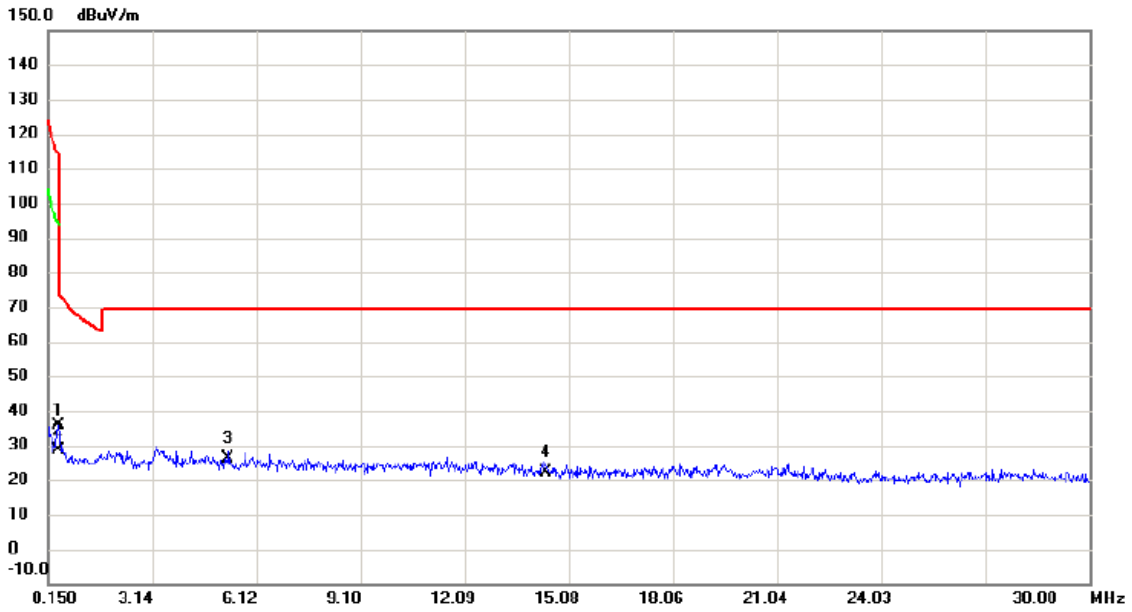

No.	Mk.	Freq. MHz	Reading Level dBuV	Correct Factor dB	Measure- ment dBuV/m	Limit dBuV/m	Margin dB	Detector	Comment
1		0.4634	17.25	18.41	35.66	114.28	-78.62	peak	
2		0.4634	10.09	18.41	28.50	94.28	-65.78	AVG	
3	*	5.3140	9.49	16.62	26.11	69.54	-43.43	QP	
4		14.4034	6.55	15.71	22.26	69.54	-47.28	QP	

**ATTACHMENT C -RADIATED EMISSION (30MHZ TO 1000MHZ)**

Test Mode: TX B MODE CHANNEL 01\_Adapter: 2AAJ012F US

**Vertical**

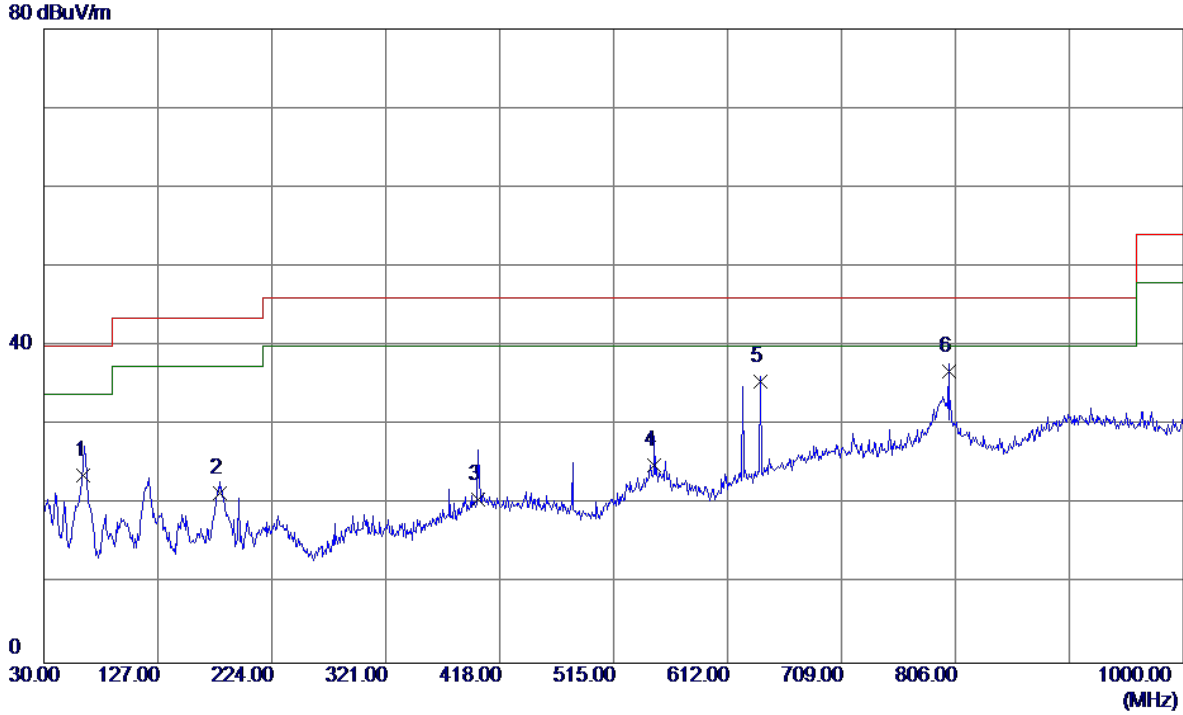

No.	Freq. MHz	Reading Level dBuV/m	Correct Factor dB	Measure ment dBuV/m	Limit dBuV/m	Margin dB	Detector	Comment
1	63.9500	38.51	-14.87	23.64	40.00	-16.36	QP	
2	179.3800	34.19	-12.80	21.39	43.50	-22.11	QP	
3	399.5700	28.47	-7.81	20.66	46.00	-25.34	QP	
4	549.9200	29.57	-4.55	25.02	46.00	-20.98	QP	
5	640.1300	40.30	-4.75	35.55	46.00	-10.45	QP	
6 *	800.1800	36.58	0.25	36.83	46.00	-9.17	QP	

Test Mode: TX B MODE CHANNEL 01\_Adapter: 2AAJ012F US

**Horizontal**

80 dBuV/m

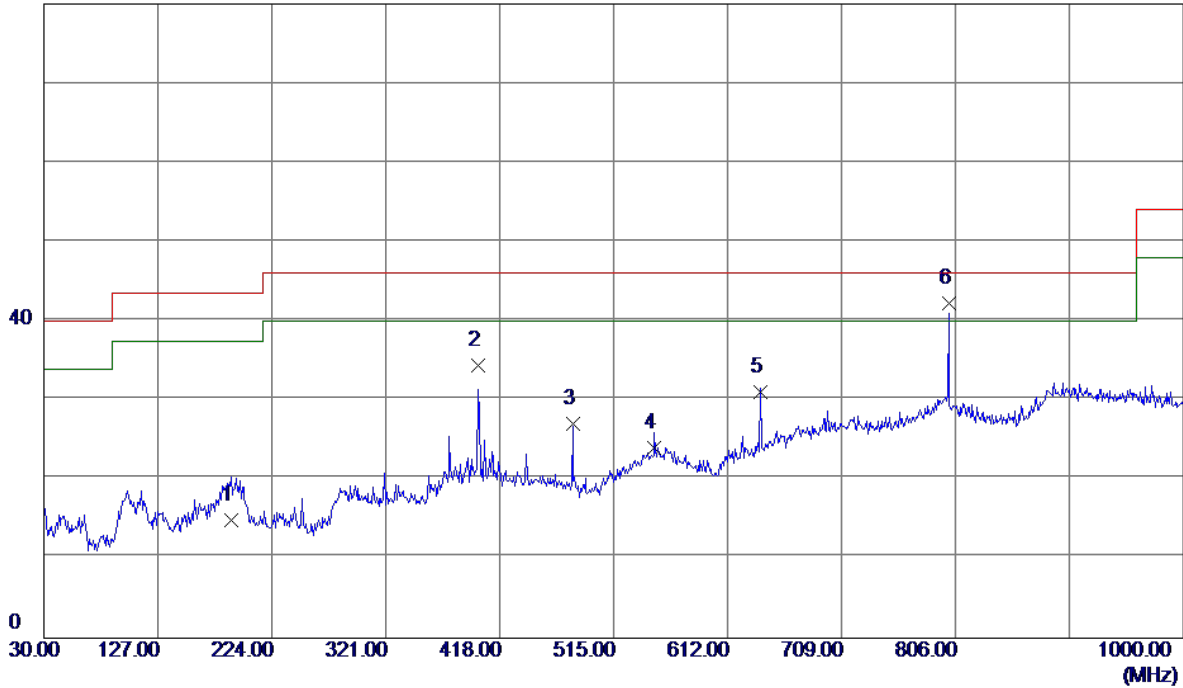

No.	Freq. MHz	Reading Level dBuV/m	Correct Factor dB	Measure ment dBuV/m	Limit dBuV/m	Margin dB	Detector	Comment
1	189.0800	28.67	-13.83	14.84	43.50	-28.66	QP	
2	399.5700	42.14	-7.81	34.33	46.00	-11.67	QP	
3	480.0800	36.02	-9.03	26.99	46.00	-19.01	QP	
4	549.9200	28.58	-4.55	24.03	46.00	-21.97	QP	
5	640.1300	35.83	-4.75	31.08	46.00	-14.92	QP	
6 *	800.1800	41.95	0.25	42.20	46.00	-3.80	QP	

Test Mode: TX B MODE CHANNEL 06\_Adapter: 2AAJ012F US

**Vertical**

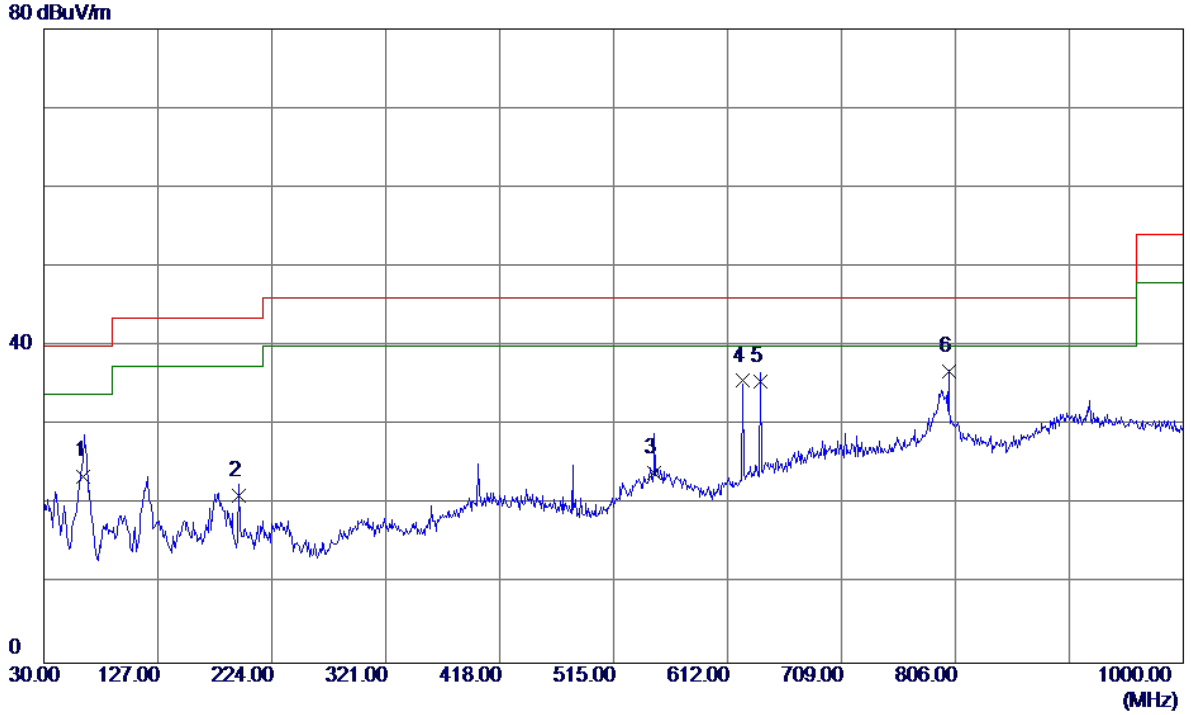

No.	Freq. MHz	Reading Level dBuV/m	Correct Factor dB	Measure ment dBuV/m	Limit dBuV/m	Margin dB	Detector	Comment
1	63.9500	38.47	-14.87	23.60	40.00	-16.40	QP	
2	195.8700	35.41	-14.23	21.18	43.50	-22.32	QP	
3	549.9200	28.57	-4.55	24.02	46.00	-21.98	QP	
4	624.6100	41.24	-5.64	35.60	46.00	-10.40	QP	
5	640.1300	40.28	-4.75	35.53	46.00	-10.47	QP	
6 *	800.1800	36.54	0.25	36.79	46.00	-9.21	QP	

Test Mode: TX B MODE CHANNEL 06\_Adapter: 2AAJ012F US

Horizontal

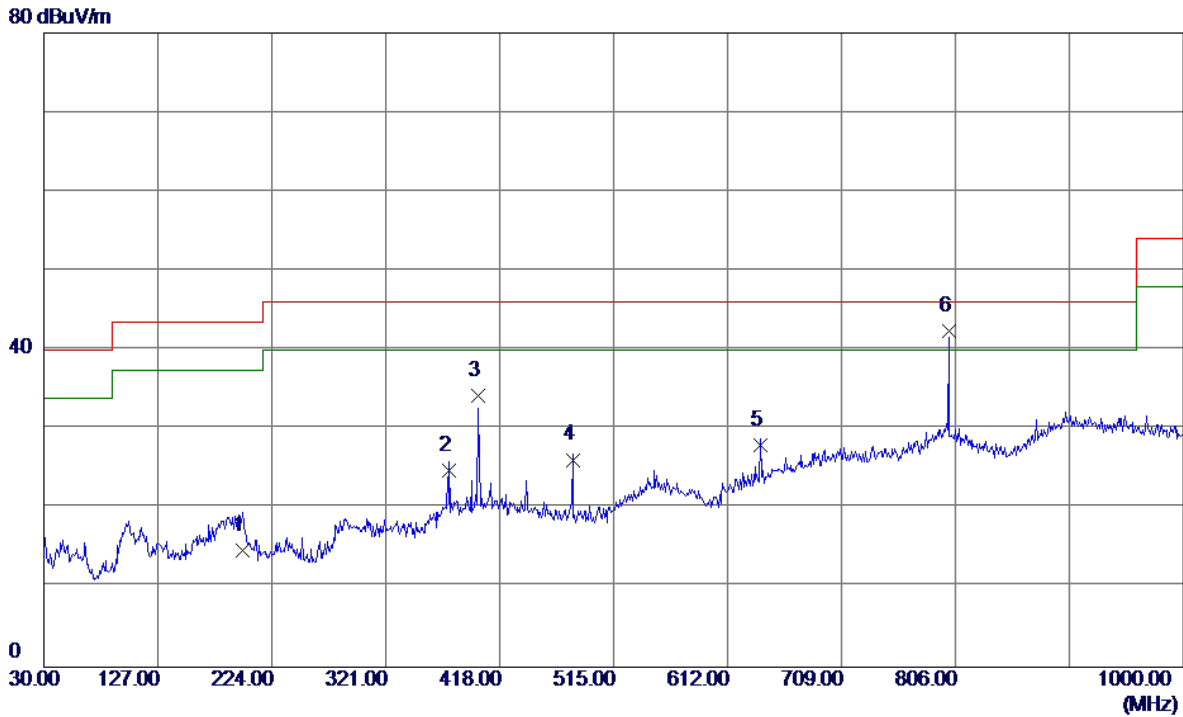

No.	Freq. MHz	Reading Level dBuV/m	Correct Factor dB	Measure ment dBuV/m	Limit dBuV/m	Margin dB	Detector	Comment
1	198.7800	29.16	-14.37	14.79	43.50	-28.71	QP	
2	375.3200	34.26	-9.48	24.78	46.00	-21.22	QP	
3	399.5700	42.10	-7.81	34.29	46.00	-11.71	QP	
4	480.0800	35.19	-9.03	26.16	46.00	-19.84	QP	
5	640.1300	32.80	-4.75	28.05	46.00	-17.95	QP	
6 *	800.1800	42.11	0.25	42.36	46.00	-3.64	QP	

Test Mode: TX B MODE CHANNEL 11\_Adapter: 2AAJ012F US

**Vertical**

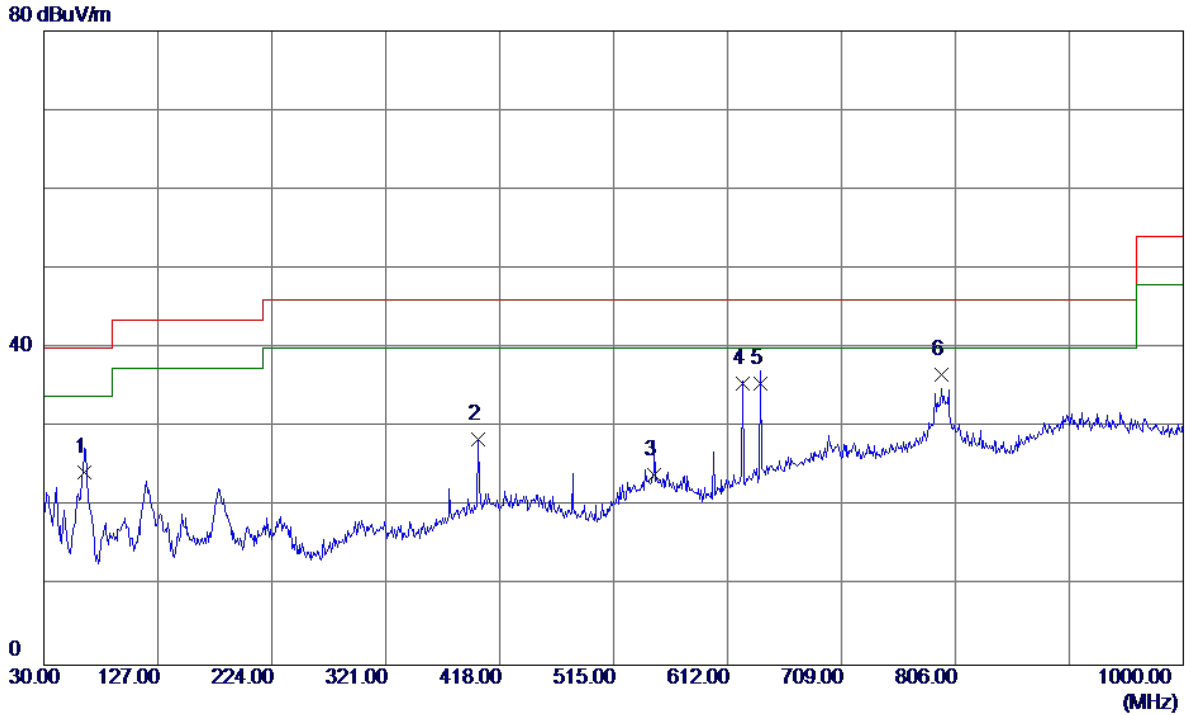

No.	Freq. MHz	Reading Level dBuV/m	Correct Factor dB	Measure ment dBuV/m	Limit dBuV/m	Margin dB	Detector	Comment
1	64.9200	39.46	-15.15	24.31	40.00	-15.69	QP	
2	399.5700	36.25	-7.81	28.44	46.00	-17.56	QP	
3	549.9200	28.49	-4.55	23.94	46.00	-22.06	QP	
4	624.6100	41.18	-5.64	35.54	46.00	-10.46	QP	
5	640.1300	40.28	-4.75	35.53	46.00	-10.47	QP	
6 *	794.3600	36.58	0.01	36.59	46.00	-9.41	QP	

Test Mode: TX B MODE CHANNEL 11\_Adapter: 2AAJ012F US

**Horizontal**

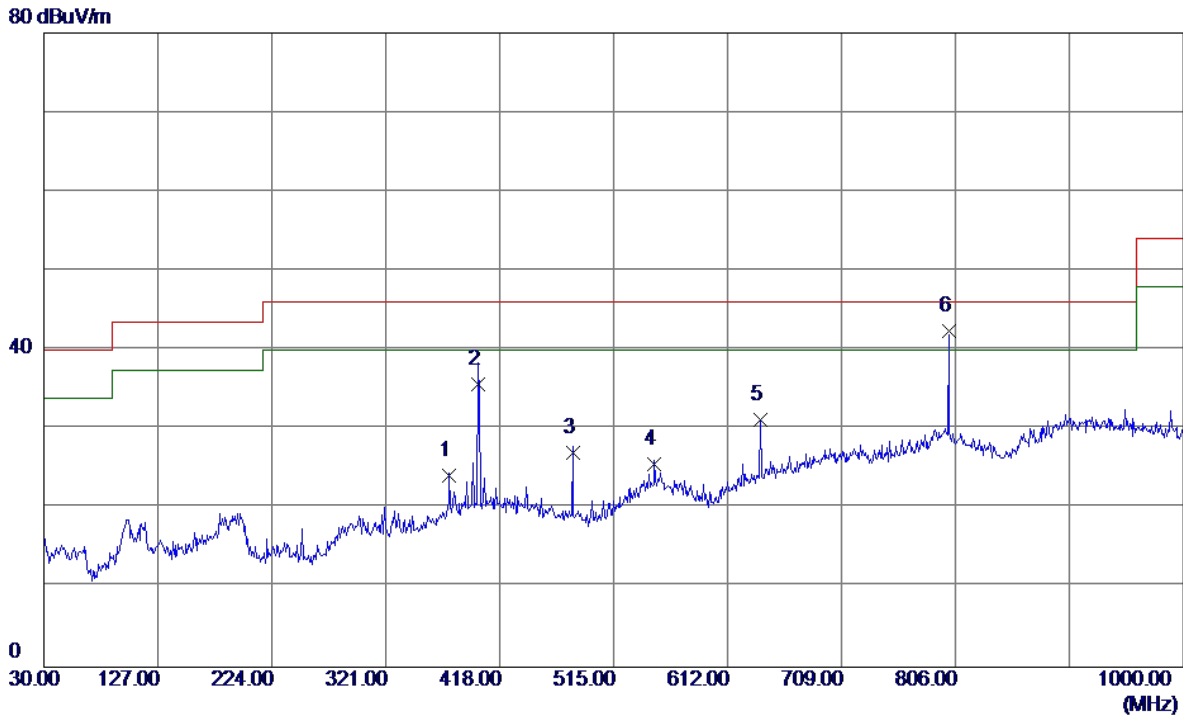

No.	Freq. MHz	Reading Level dBuV/m	Correct Factor dB	Measure ment dBuV/m	Limit dBuV/m	Margin dB	Detector	Comment
1	375.3200	33.62	-9.48	24.14	46.00	-21.86	QP	
2	399.5700	43.56	-7.81	35.75	46.00	-10.25	QP	
3	480.0800	36.06	-9.03	27.03	46.00	-18.97	QP	
4	549.9200	30.16	-4.55	25.61	46.00	-20.39	QP	
5	640.1300	35.88	-4.75	31.13	46.00	-14.87	QP	
6 *	800.1800	42.16	0.25	42.41	46.00	-3.59	QP	

Test Mode: TX B MODE CHANNEL 01\_ Adapter:MU12AR120100-A1

**Vertical**

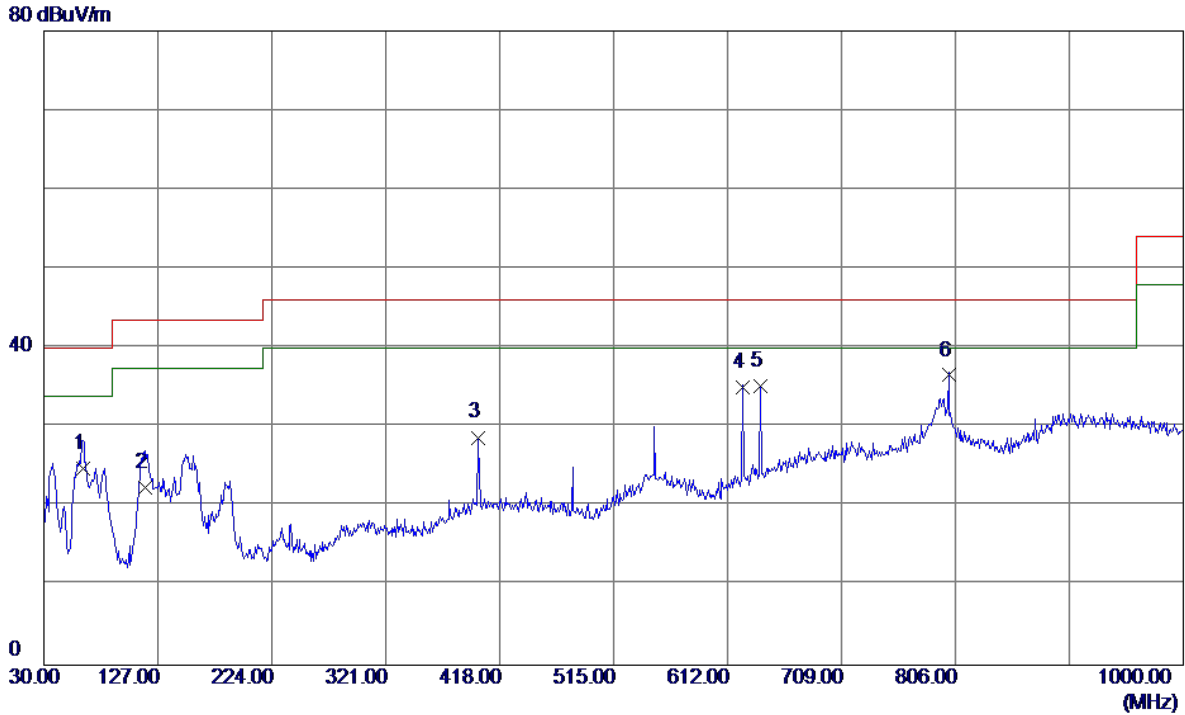

No.	Freq. MHz	Reading Level dBuV/m	Correct Factor dB	Measure ment dBuV/m	Limit dBuV/m	Margin dB	Detector	Comment
1	62.9800	39.37	-14.58	24.79	40.00	-15.21	QP	
2	116.3300	36.30	-13.90	22.40	43.50	-21.10	QP	
3	399.5700	36.53	-7.81	28.72	46.00	-17.28	QP	
4	624.6100	40.68	-5.64	35.04	46.00	-10.96	QP	
5	640.1300	40.02	-4.75	35.27	46.00	-10.73	QP	
6 *	800.1800	36.31	0.25	36.56	46.00	-9.44	QP	

Test Mode: TX B MODE CHANNEL 01\_ Adapter:MU12AR120100-A1

**Horizontal**

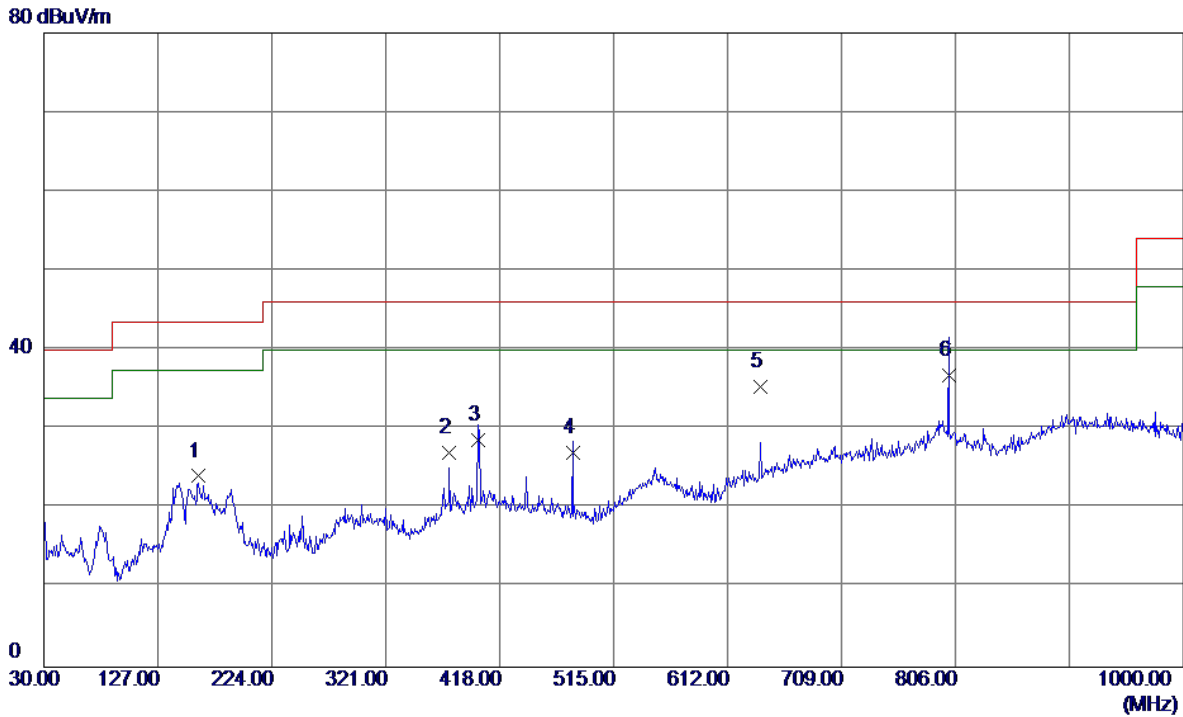

No.	Freq. MHz	Reading Level dBuV/m	Correct Factor dB	Measure ment dBuV/m	Limit dBuV/m	Margin dB	Detector	Comment
1	161.9200	36.24	-12.16	24.08	43.50	-19.42	QP	
2	375.3200	36.52	-9.48	27.04	46.00	-18.96	QP	
3	399.5700	36.41	-7.81	28.60	46.00	-17.40	QP	
4	480.0800	36.09	-9.03	27.06	46.00	-18.94	QP	
5	640.1300	40.07	-4.75	35.32	46.00	-10.68	QP	
6 *	800.1800	36.49	0.25	36.74	46.00	-9.26	QP	

Test Mode: TX B MODE CHANNEL 06\_ Adapter:MU12AR120100-A1

**Vertical**

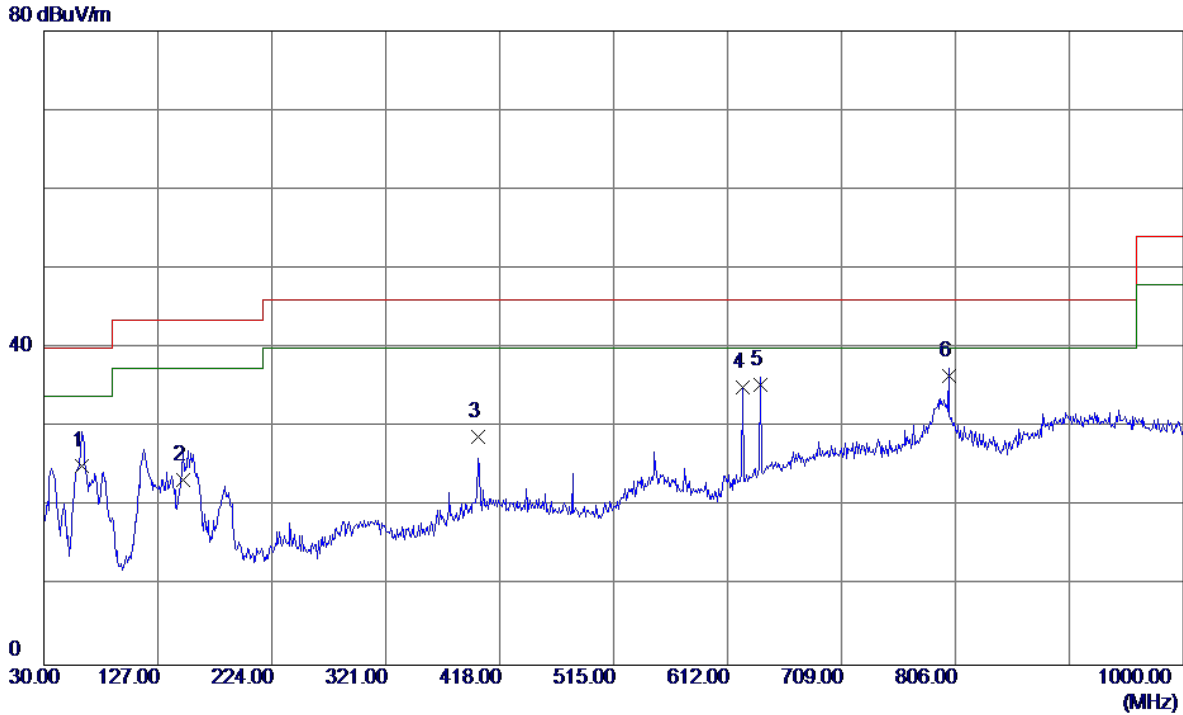

No.	Freq. MHz	Reading Level dBuV/m	Correct Factor dB	Measure ment dBuV/m	Limit dBuV/m	Margin dB	Detector	Comment
1	62.0100	39.35	-14.30	25.05	40.00	-14.95	QP	
2	148.3400	36.48	-13.08	23.40	43.50	-20.10	QP	
3	399.5700	36.54	-7.81	28.73	46.00	-17.27	QP	
4	624.6100	40.64	-5.64	35.00	46.00	-11.00	QP	
5	640.1300	40.04	-4.75	35.29	46.00	-10.71	QP	
6 *	800.1800	36.25	0.25	36.50	46.00	-9.50	QP	

Test Mode: TX B MODE CHANNEL 06\_ Adapter:MU12AR120100-A1

**Horizontal**

80 dBuV/m

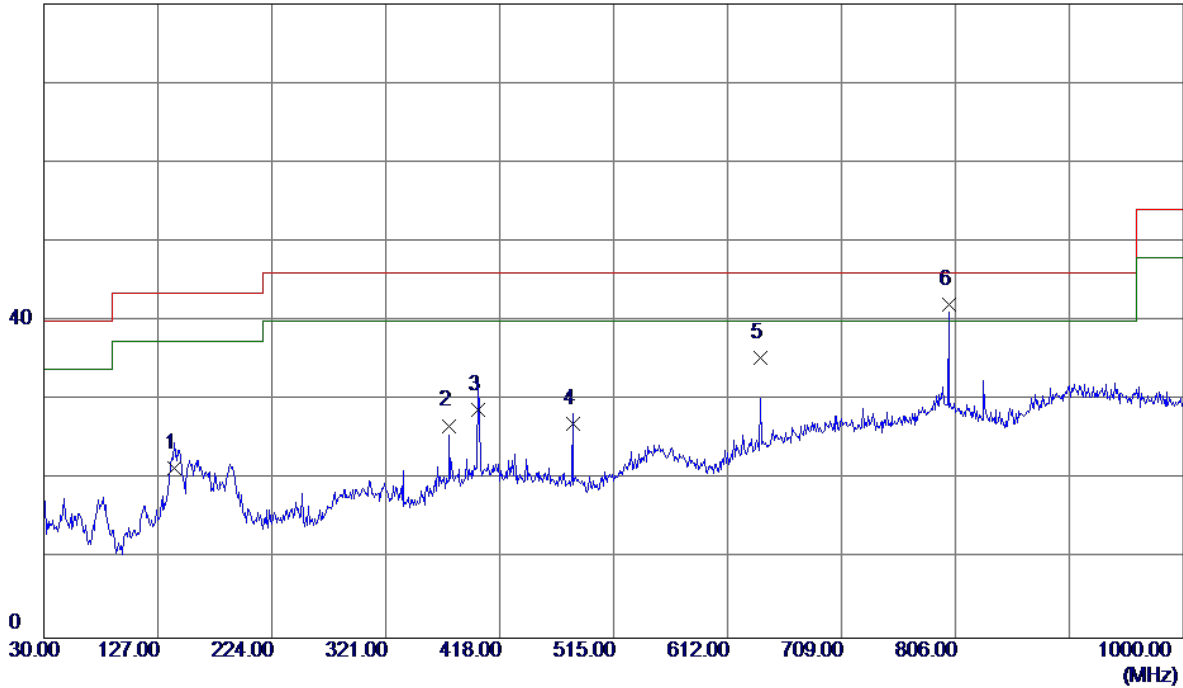

No.	Freq. MHz	Reading Level dBuV/m	Correct Factor dB	Measure ment dBuV/m	Limit dBuV/m	Margin dB	Detector	Comment
1	140.5800	35.12	-13.71	21.41	43.50	-22.09	QP	
2	375.3200	36.28	-9.48	26.80	46.00	-19.20	QP	
3	399.5700	36.54	-7.81	28.73	46.00	-17.27	QP	
4	480.0800	36.07	-9.03	27.04	46.00	-18.96	QP	
5	640.1300	40.07	-4.75	35.32	46.00	-10.68	QP	
6 *	800.1800	41.80	0.25	42.05	46.00	-3.95	QP	

Test Mode: TX B MODE CHANNEL 11\_ Adapter:MU12AR120100-A1

**Vertical**

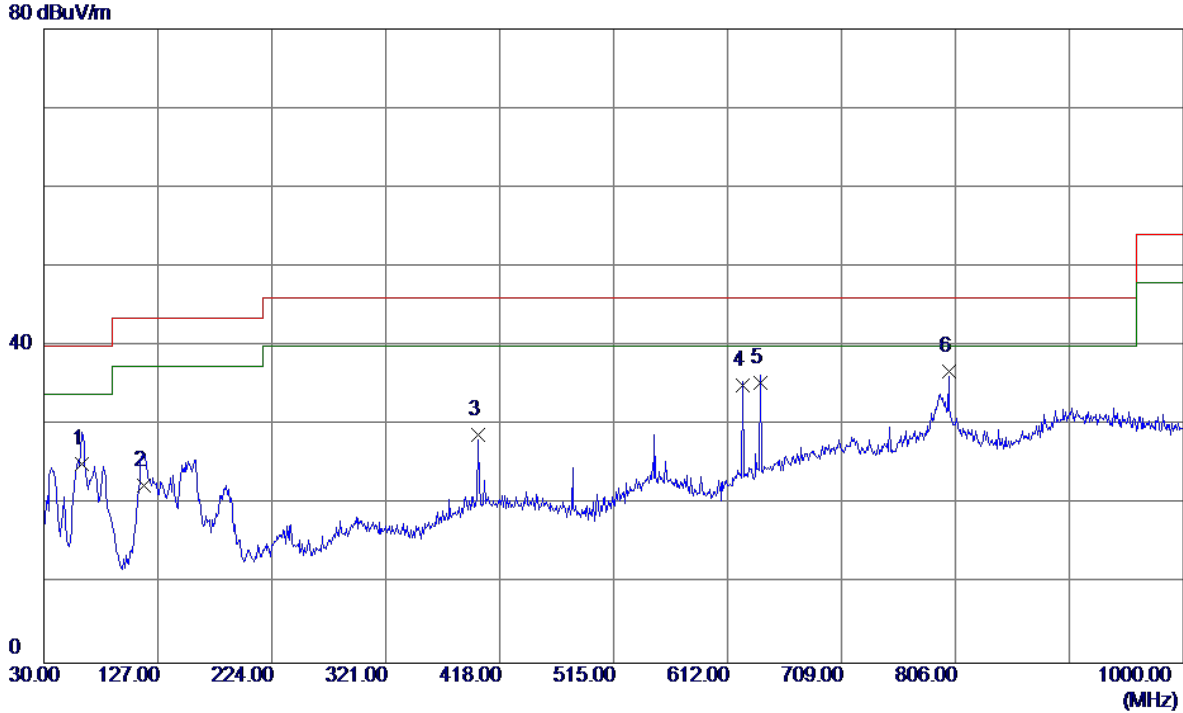

No.	Freq. MHz	Reading Level dBuV/m	Correct Factor dB	Measure ment dBuV/m	Limit dBuV/m	Margin dB	Detector	Comment
1	62.0100	39.39	-14.30	25.09	40.00	-14.91	QP	
2	115.3600	36.46	-14.01	22.45	43.50	-21.05	QP	
3	399.5700	36.59	-7.81	28.78	46.00	-17.22	QP	
4	624.6100	40.61	-5.64	34.97	46.00	-11.03	QP	
5	640.1300	40.07	-4.75	35.32	46.00	-10.68	QP	
6 *	800.1800	36.51	0.25	36.76	46.00	-9.24	QP	

Test Mode: TX B MODE CHANNEL 11\_ Adapter:MU12AR120100-A1

Horizontal

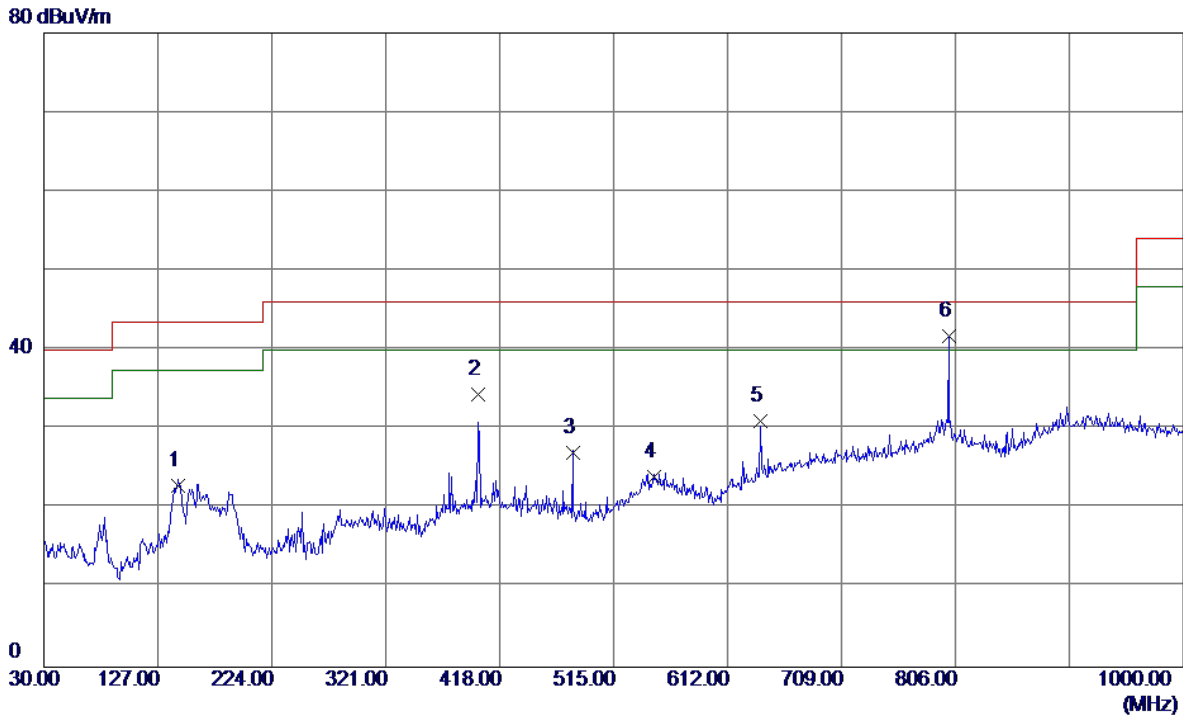

No.	Freq. MHz	Reading Level dBuV/m	Correct Factor dB	Measure ment dBuV/m	Limit dBuV/m	Margin dB	Detector	Comment
1	144.4600	36.24	-13.39	22.85	43.50	-20.65	QP	
2	399.5700	42.16	-7.81	34.35	46.00	-11.65	QP	
3	480.0800	36.08	-9.03	27.05	46.00	-18.95	QP	
4	549.9200	28.49	-4.55	23.94	46.00	-22.06	QP	
5	640.1300	35.82	-4.75	31.07	46.00	-14.93	QP	
6 *	800.1800	41.52	0.25	41.77	46.00	-4.23	QP	

**ATTACHMENT D -RADIATED EMISSION (ABOVE 1000MHZ)**

Orthogonal Axis :	X
Test Mode :	TX B MODE 2412MHz

**Vertical**

120 dBuV/m

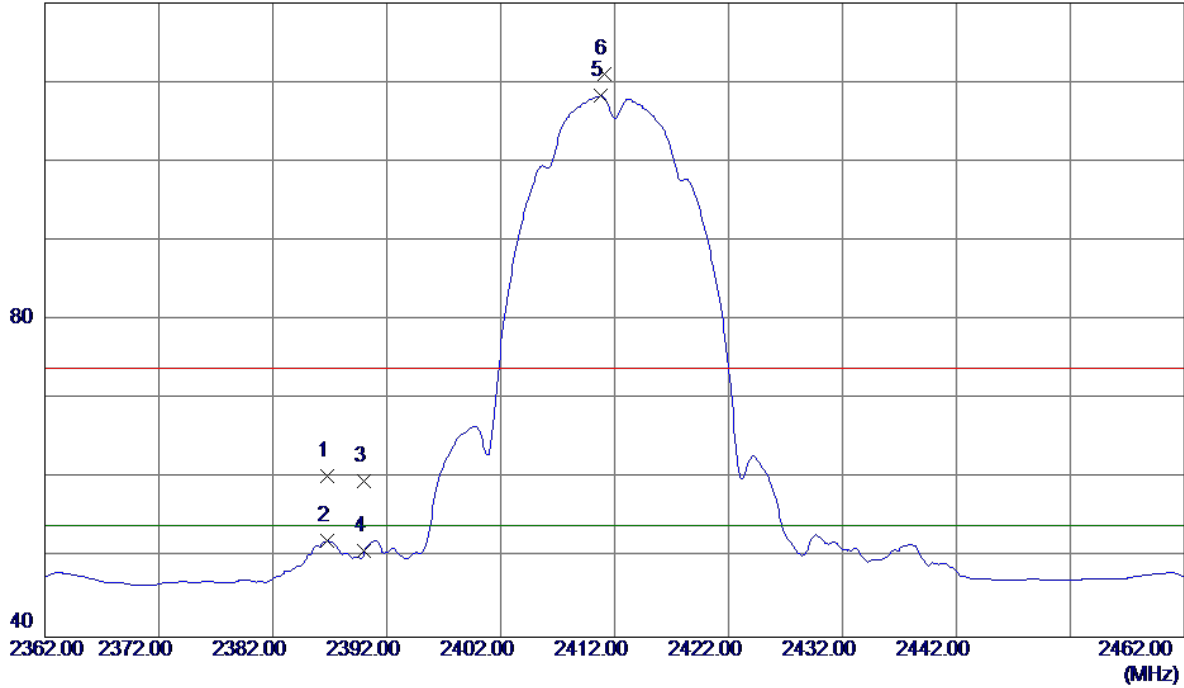

No.	Freq. MHz	Reading Level dBuV/m	Correct Factor dB	Measure ment dBuV/m	Limit dBuV/m	Margin dB	Detector	Comment
1	2386.7500	27.30	33.00	60.30	74.00	-13.70	Peak	
2	2386.7500	19.10	33.00	52.10	54.00	-1.90	AVG	
3	2390.0000	26.62	33.01	59.63	74.00	-14.37	Peak	
4	2390.0000	17.88	33.01	50.89	54.00	-3.11	AVG	
5 *	2410.7500	75.18	33.10	108.28	54.00	54.28	AVG	No Limit
6	2411.1500	77.94	33.10	111.04	74.00	37.04	Peak	No Limit

Orthogonal Axis :	X
Test Mode :	TX B MODE 2412MHz

**Vertical**

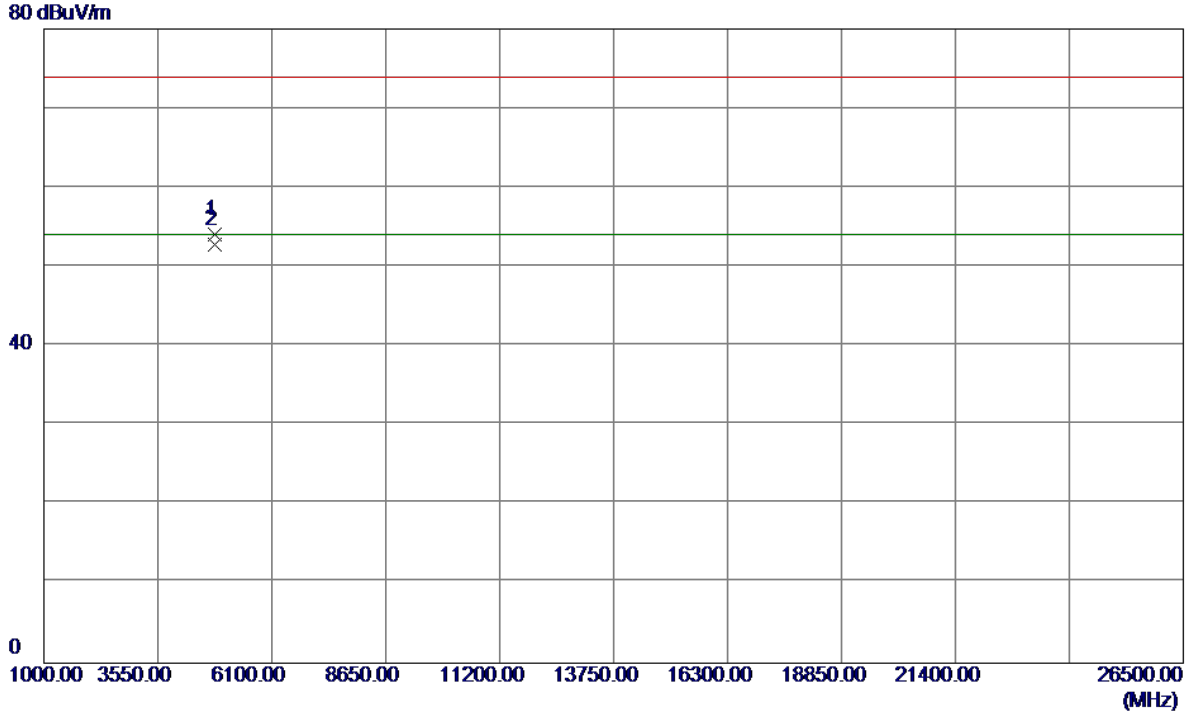

No.	Freq. MHz	Reading Level dBuV/m	Correct Factor dB	Measure ment dBuV/m	Limit dBuV/m	Margin dB	Detector	Comment
1	4823.9290	49.27	4.85	54.12	74.00	-19.88	Peak	
2 *	4823.9800	48.00	4.85	52.85	54.00	-1.15	AVG	

Orthogonal Axis :	X
Test Mode :	TX B MODE 2412MHz

**Horizontal**

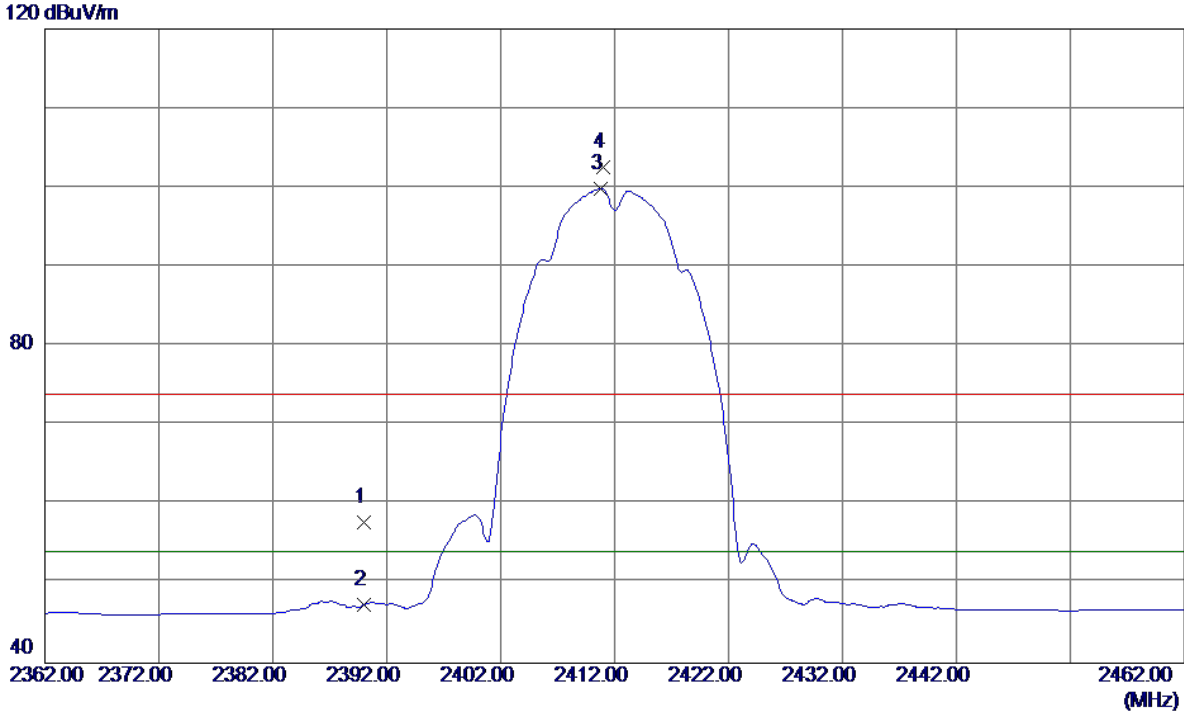

No.	Freq. MHz	Reading Level dBuV/m	Correct Factor dB	Measure ment dBuV/m	Limit dBuV/m	Margin dB	Detector	Comment
1	2390.0000	24.77	33.01	57.78	74.00	-16.22	Peak	
2	2390.0000	14.39	33.01	47.40	54.00	-6.60	AVG	
3 *	2410.7500	66.77	33.10	99.87	54.00	45.87	AVG	No Limit
4	2411.0500	69.38	33.10	102.48	74.00	28.48	Peak	No Limit

Orthogonal Axis :	X
Test Mode :	TX B MODE 2412MHz

**Horizontal**

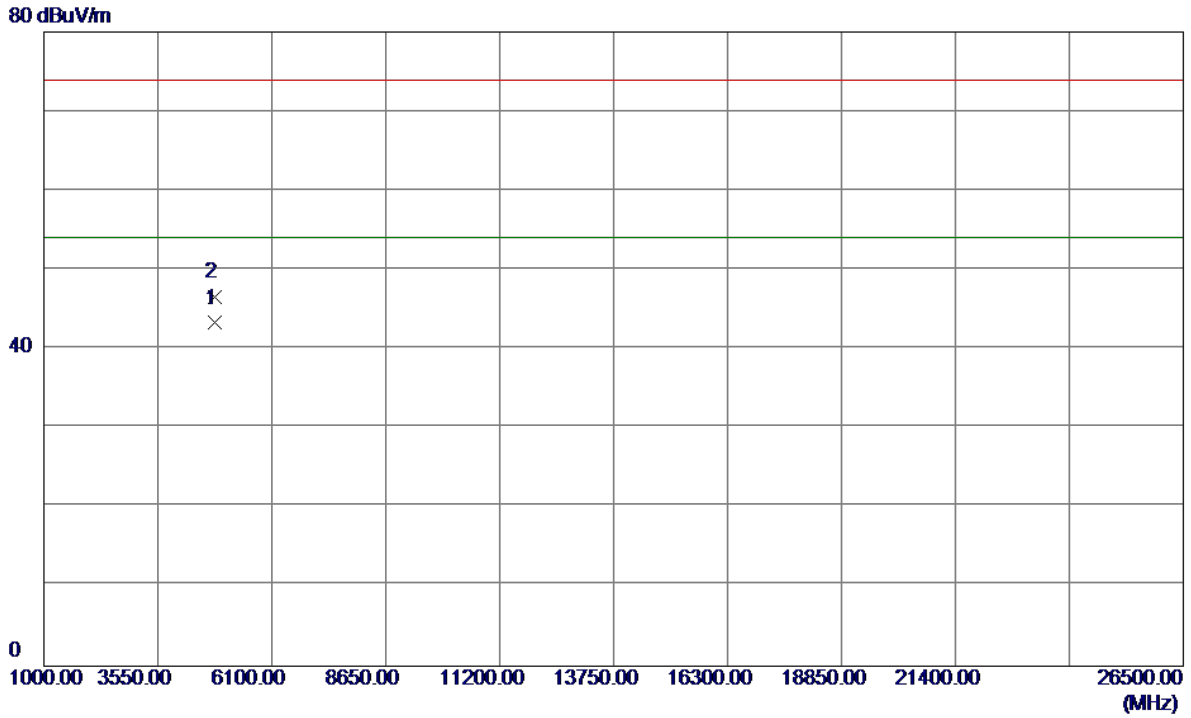

No.	Freq. MHz	Reading Level dBuV/m	Correct Factor dB	Measure ment dBuV/m	Limit dBuV/m	Margin dB	Detector	Comment
1 *	4823.9800	38.43	4.85	43.28	54.00	-10.72	AVG	
2	4823.9900	41.71	4.85	46.56	74.00	-27.44	Peak	

Orthogonal Axis :	X
Test Mode :	TX B MODE 2437MHz

**Vertical**

120 dBuV/m

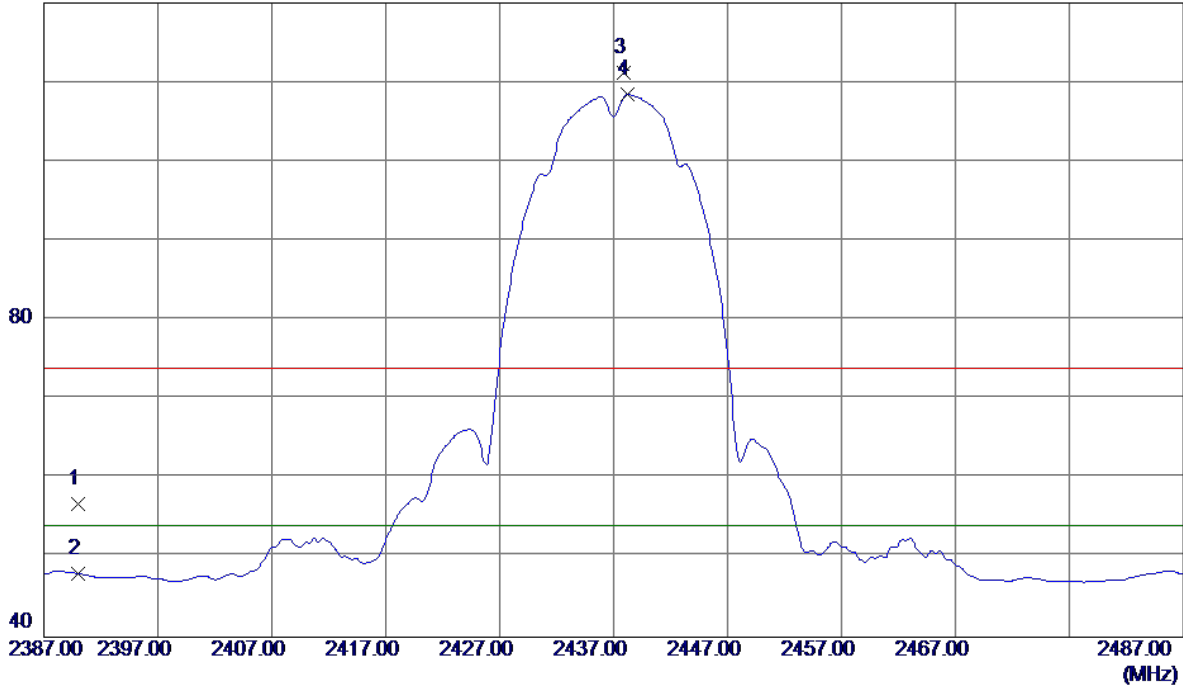

No.	Freq. MHz	Reading Level dBuV/m	Correct Factor dB	Measure ment dBuV/m	Limit dBuV/m	Margin dB	Detector	Comment
1	2390.0000	23.76	33.01	56.77	74.00	-17.23	Peak	
2	2390.0000	15.04	33.01	48.05	54.00	-5.95	AVG	
3	2437.9000	77.96	33.21	111.17	74.00	37.17	Peak	No Limit
4 *	2438.2500	75.26	33.21	108.47	54.00	54.47	AVG	No Limit

Orthogonal Axis :	X
Test Mode :	TX B MODE 2437MHz

**Vertical**

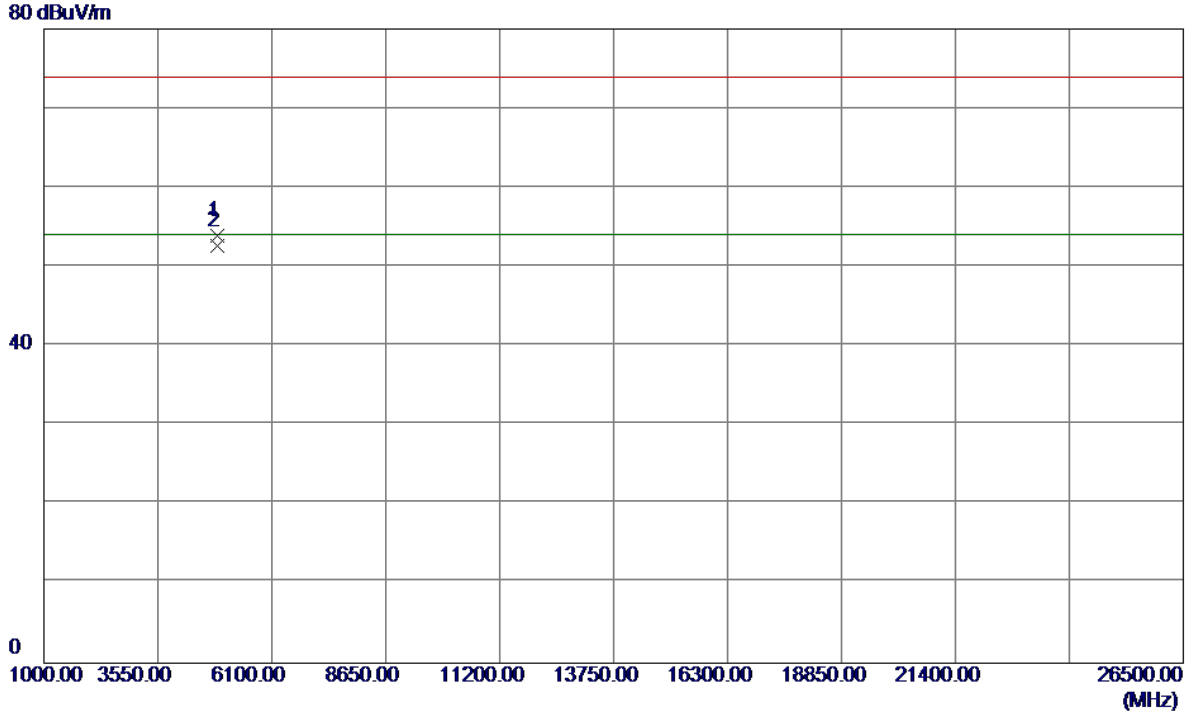

No.	Freq. MHz	Reading Level dBuV/m	Correct Factor dB	Measure ment dBuV/m	Limit dBuV/m	Margin dB	Detector	Comment
1	4873.9490	48.89	5.07	53.96	74.00	-20.04	Peak	
2 *	4873.9800	47.51	5.07	52.58	54.00	-1.42	AVG	

Orthogonal Axis :	X
Test Mode :	TX B MODE 2437MHz

**Horizontal**

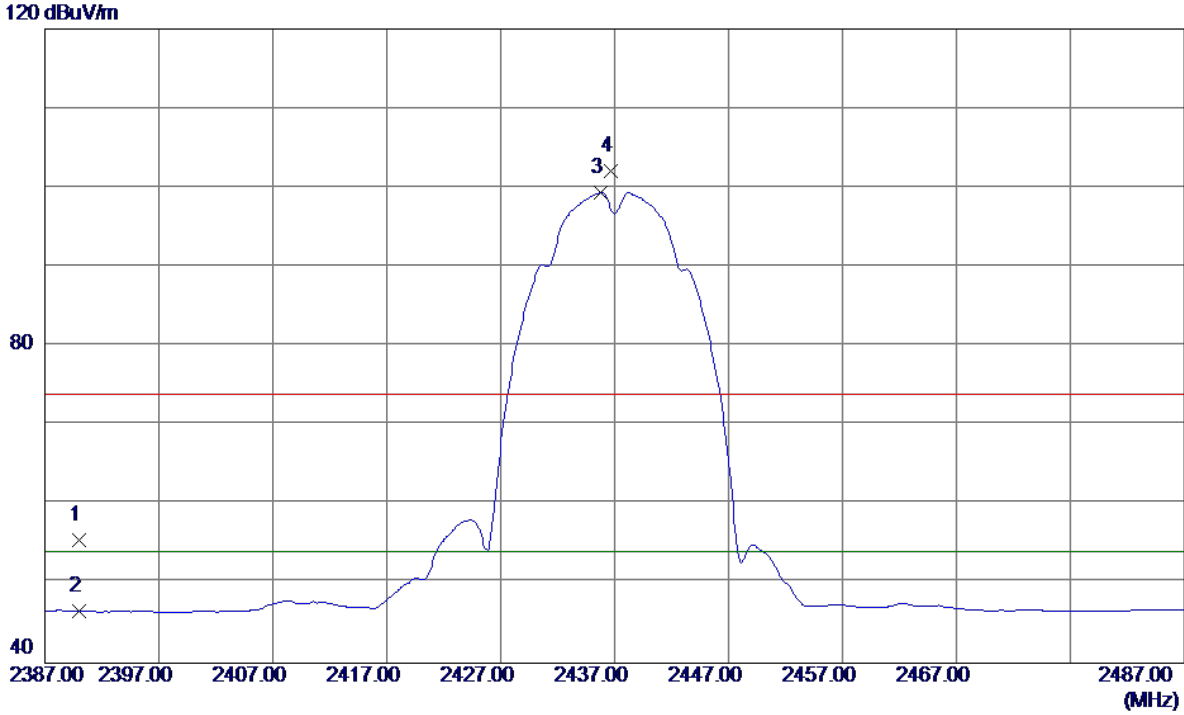

No.	Freq. MHz	Reading Level dBuV/m	Correct Factor dB	Measure ment dBuV/m	Limit dBuV/m	Margin dB	Detector	Comment
1	2390.0000	22.51	33.01	55.52	74.00	-18.48	Peak	
2	2390.0000	13.58	33.01	46.59	54.00	-7.41	AVG	
3 *	2435.8000	66.18	33.20	99.38	54.00	45.38	AVG	No Limit
4	2436.6500	68.95	33.21	102.16	74.00	28.16	Peak	No Limit

Orthogonal Axis :	X
Test Mode :	TX B MODE 2437MHz

**Horizontal**

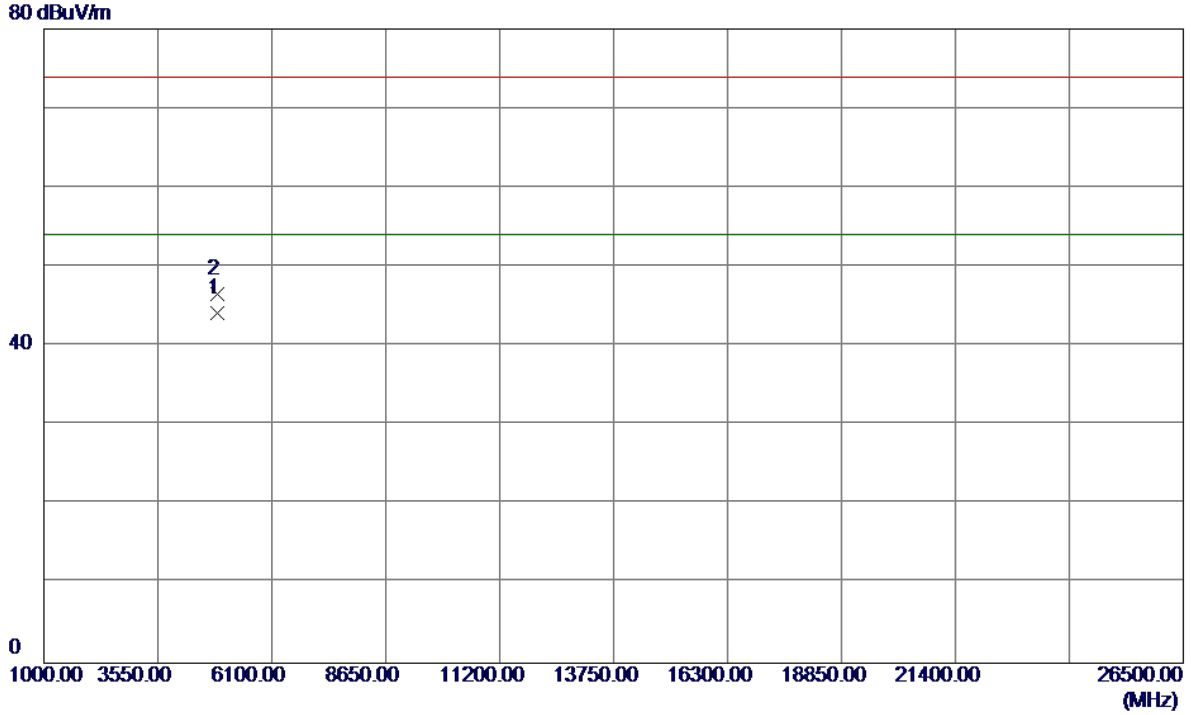

No.	Freq. MHz	Reading Level dBuV/m	Correct Factor dB	Measure ment dBuV/m	Limit dBuV/m	Margin dB	Detector	Comment
1 *	4873.9800	39.12	5.07	44.19	54.00	-9.81	AVG	
2	4873.9900	41.53	5.07	46.60	74.00	-27.40	Peak	

Orthogonal Axis :	X
Test Mode :	TX B MODE 2462MHz

**Vertical**

120 dBuV/m

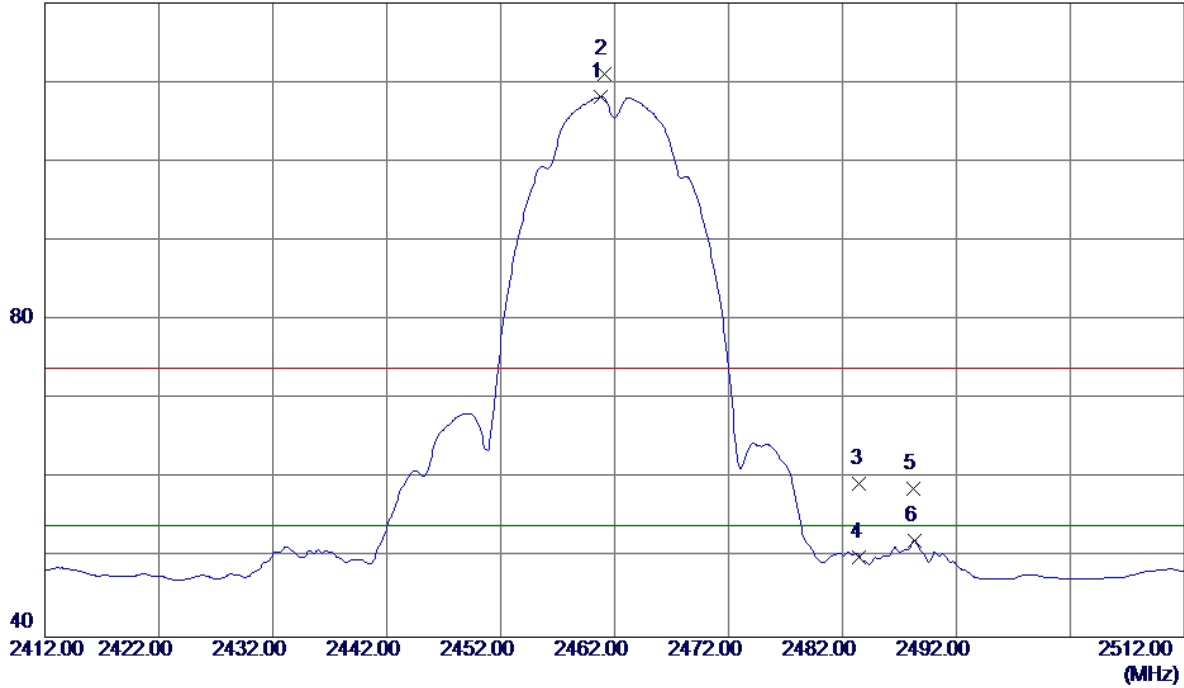

No.	Freq. MHz	Reading Level dBuV/m	Correct Factor dB	Measure ment dBuV/m	Limit dBuV/m	Margin dB	Detector	Comment
1 *	2460.7500	74.88	33.31	108.19	54.00	54.19	AVG	No Limit
2	2461.1500	77.68	33.31	110.99	74.00	36.99	Peak	No Limit
3	2483.5000	26.01	33.40	59.41	74.00	-14.59	Peak	
4	2483.5000	16.73	33.40	50.13	54.00	-3.87	AVG	
5	2488.2500	25.36	33.42	58.78	74.00	-15.22	Peak	
6	2488.3000	18.69	33.42	52.11	54.00	-1.89	AVG	

Orthogonal Axis :	X
Test Mode :	TX B MODE 2462MHz

**Vertical**

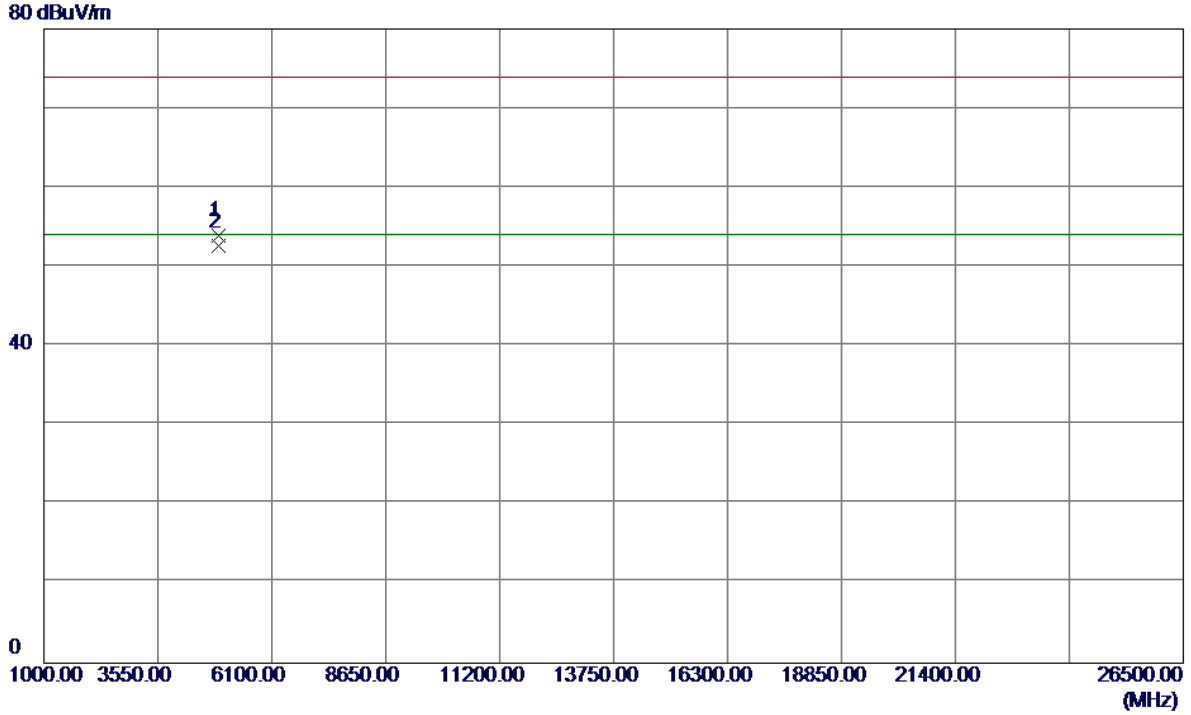

No.	Freq. MHz	Reading Level dBuV/m	Correct Factor dB	Measure ment dBuV/m	Limit dBuV/m	Margin dB	Detector	Comment
1	4923.9800	48.66	5.28	53.94	74.00	-20.06	Peak	
2 *	4923.9800	47.28	5.28	52.56	54.00	-1.44	AVG	

Orthogonal Axis :	X
Test Mode :	TX B MODE 2462MHz

**Horizontal**

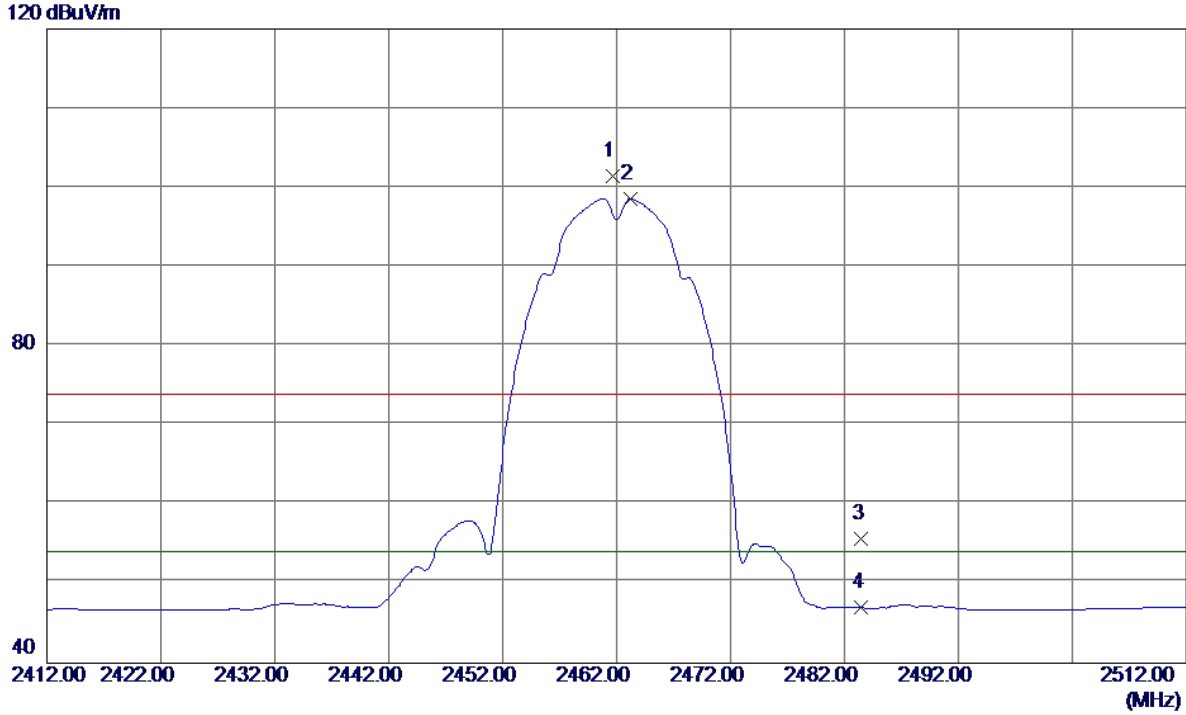

No.	Freq. MHz	Reading Level dBuV/m	Correct Factor dB	Measure ment dBuV/m	Limit dBuV/m	Margin dB	Detector	Comment
1	2461.6500	68.20	33.31	101.51	74.00	27.51	Peak	No Limit
2 *	2463.2000	65.30	33.32	98.62	54.00	44.62	AVG	No Limit
3	2483.5000	22.31	33.40	55.71	74.00	-18.29	Peak	
4	2483.5000	13.59	33.40	46.99	54.00	-7.01	AVG	

Orthogonal Axis :	X
Test Mode :	TX B MODE 2462MHz

**Horizontal**

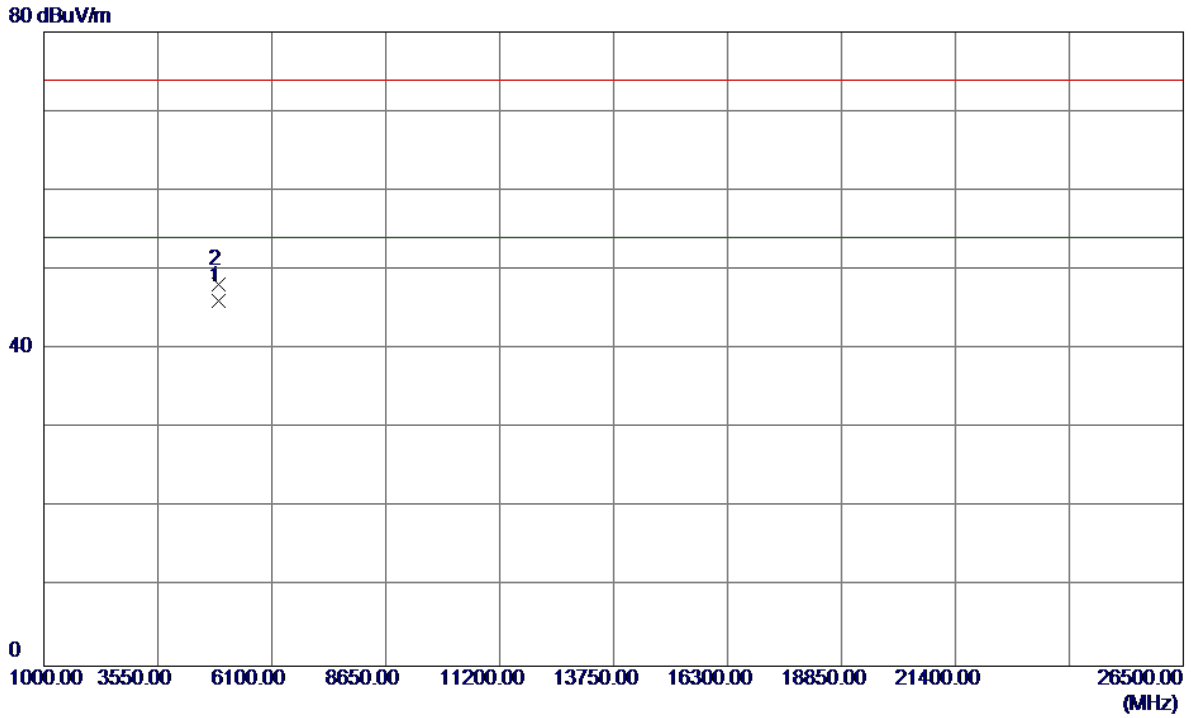

No.	Freq. MHz	Reading Level dBuV/m	Correct Factor dB	Measure ment dBuV/m	Limit dBuV/m	Margin dB	Detector	Comment
1 *	4923.9800	40.81	5.28	46.09	54.00	-7.91	AVG	
2	4924.0000	42.82	5.28	48.10	74.00	-25.90	Peak	

Orthogonal Axis :	X
Test Mode :	TX G MODE 2412MHz

**Vertical**

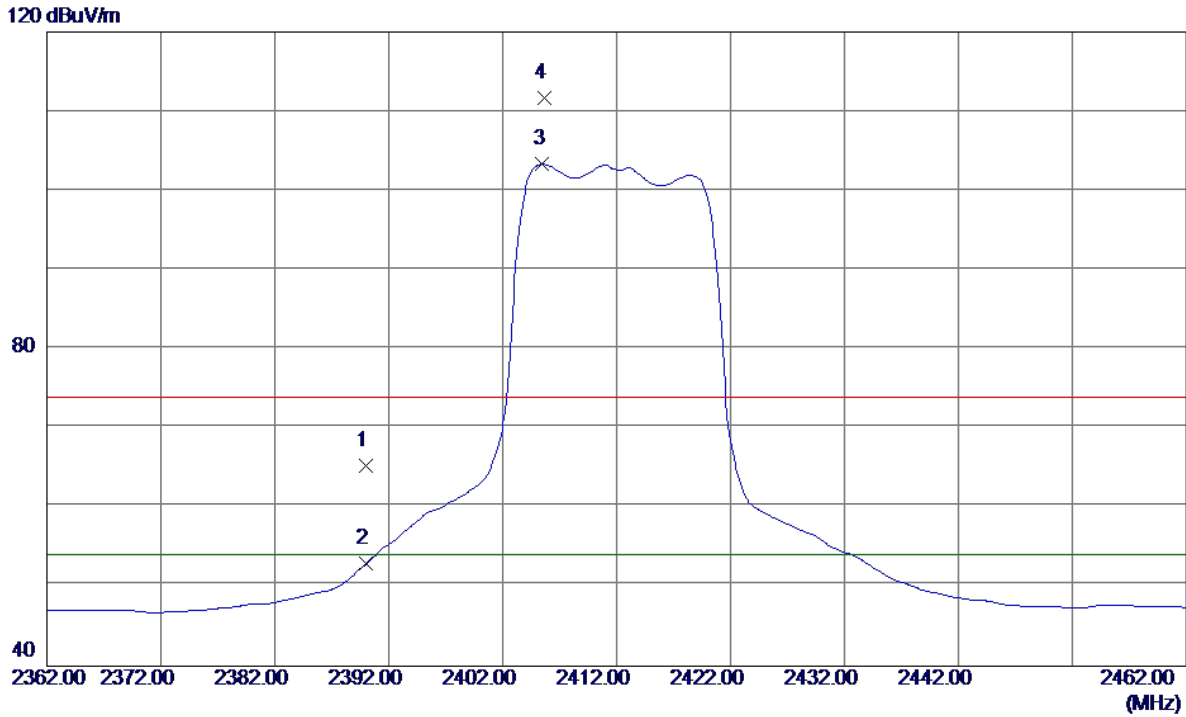

No.	Freq. MHz	Reading Level dBuV/m	Correct Factor dB	Measure ment dBuV/m	Limit dBuV/m	Margin dB	Detector	Comment
1	2390.0000	32.30	33.01	65.31	74.00	-8.69	Peak	
2	2390.0000	19.91	33.01	52.92	54.00	-1.08	AVG	
3 *	2405.5000	70.24	33.07	103.31	54.00	49.31	AVG	No Limit
4	2405.6500	78.59	33.08	111.67	74.00	37.67	Peak	No Limit

Orthogonal Axis :	X
Test Mode :	TX G MODE 2412MHz

**Vertical**

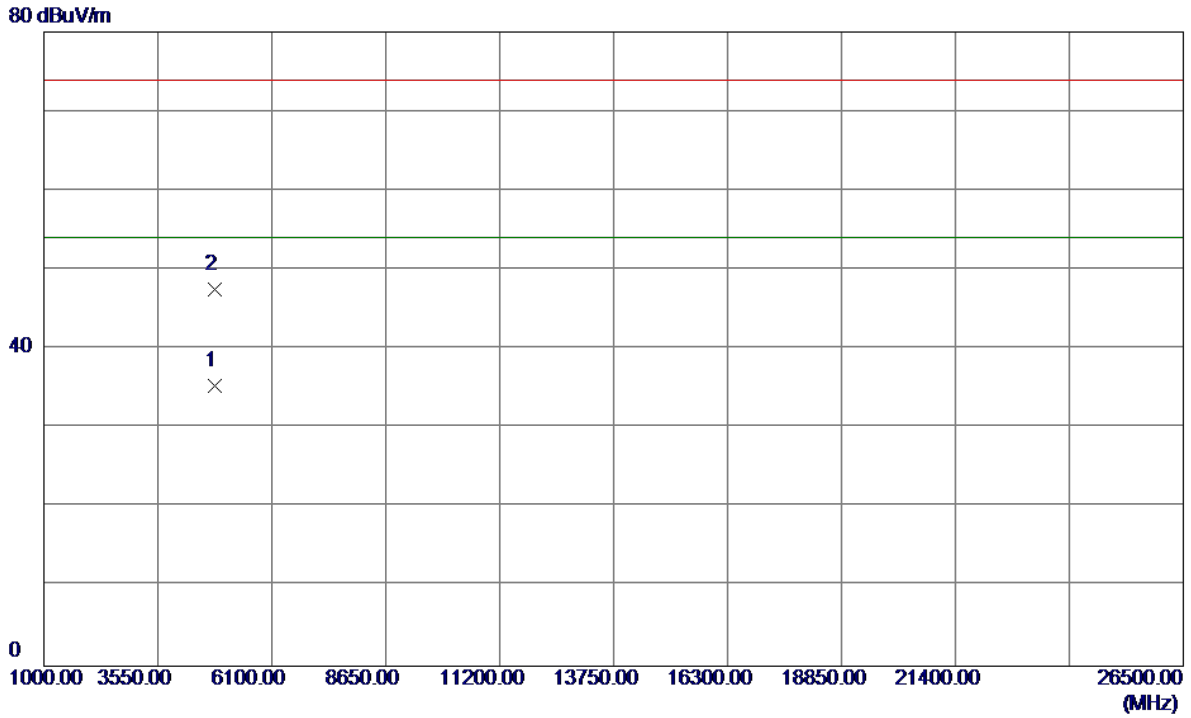

No.	Freq. MHz	Reading Level dBuV/m	Correct Factor dB	Measure ment dBuV/m	Limit dBuV/m	Margin dB	Detector	Comment
1 *	4824.2500	30.56	4.85	35.41	54.00	-18.59	AVG	
2	4824.8500	42.62	4.86	47.48	74.00	-26.52	Peak	

Orthogonal Axis :	X
Test Mode :	TX G MODE 2412MHz

**Horizontal**

120 dBuV/m

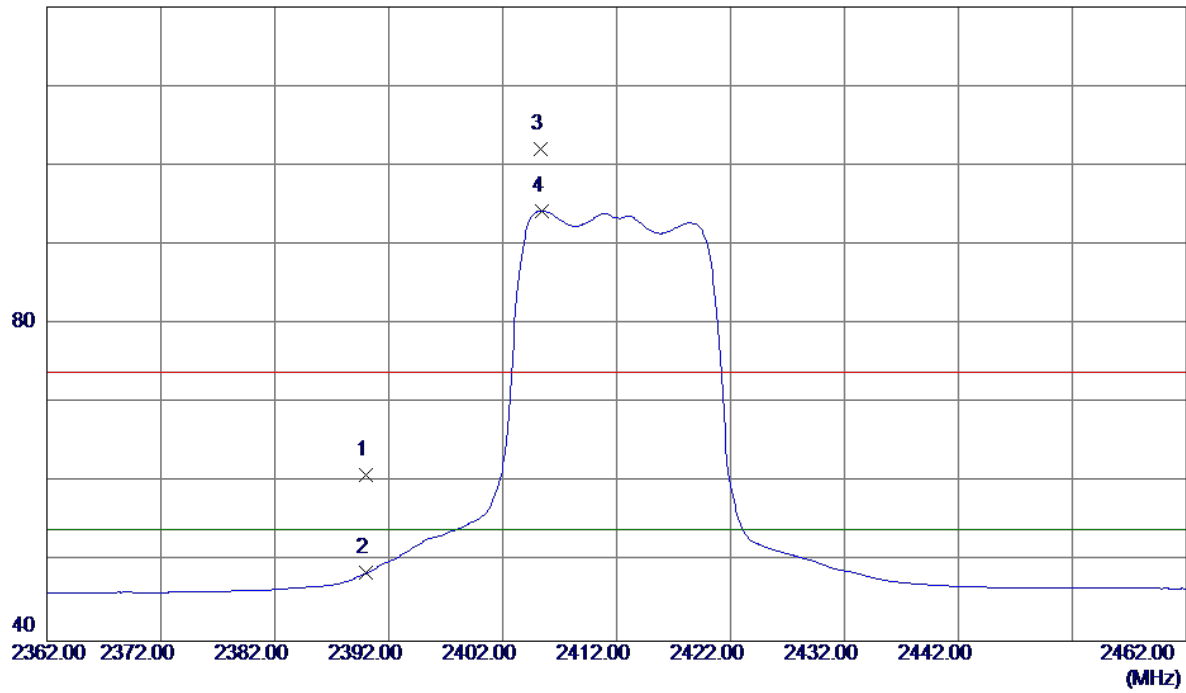

No.	Freq. MHz	Reading Level dBuV/m	Correct Factor dB	Measure ment dBuV/m	Limit dBuV/m	Margin dB	Detector	Comment
1	2390.0000	27.91	33.01	60.92	74.00	-13.08	Peak	
2	2390.0000	15.56	33.01	48.57	54.00	-5.43	AVG	
3	2405.3500	68.97	33.07	102.04	74.00	28.04	Peak	No Limit
4 *	2405.4000	61.22	33.07	94.29	54.00	40.29	AVG	No Limit

Orthogonal Axis :	X
Test Mode :	TX G MODE 2412MHz

**Horizontal**

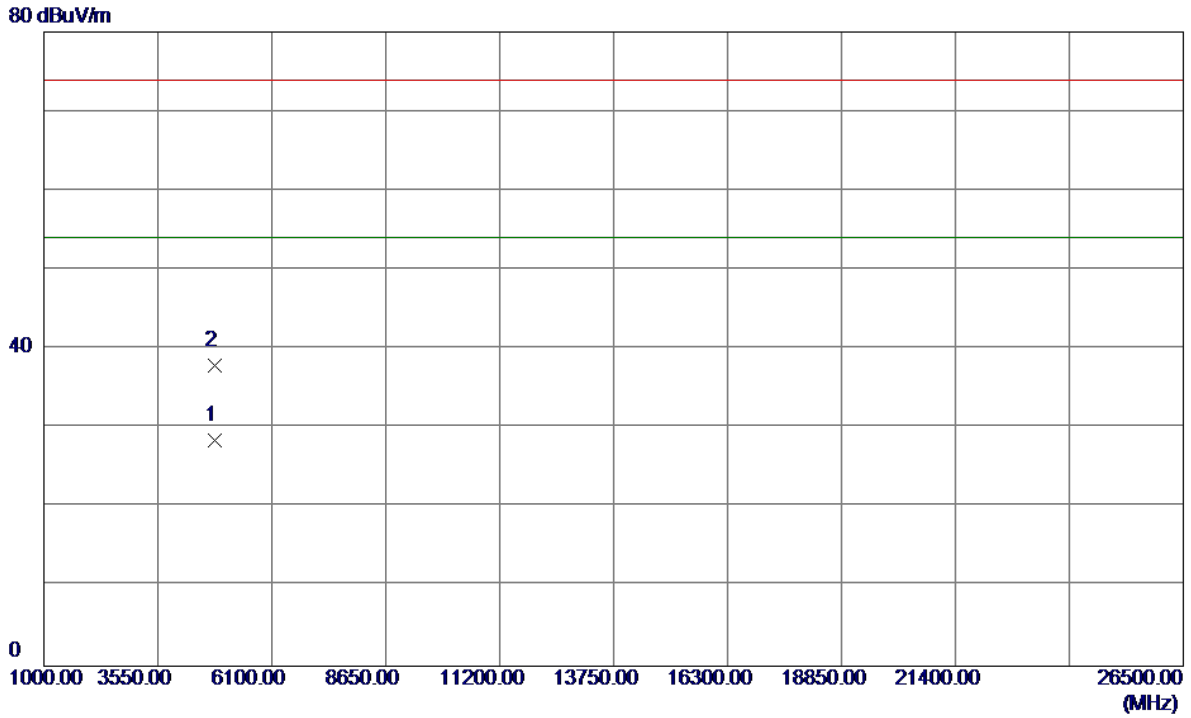

No.	Freq. MHz	Reading Level dBuV/m	Correct Factor dB	Measure ment dBuV/m	Limit dBuV/m	Margin dB	Detector	Comment
1 *	4822.2000	23.62	4.85	28.47	54.00	-25.53	AVG	
2	4824.7000	33.13	4.86	37.99	74.00	-36.01	Peak	

Orthogonal Axis :	X
Test Mode :	TX G MODE 2437MHz

**Vertical**

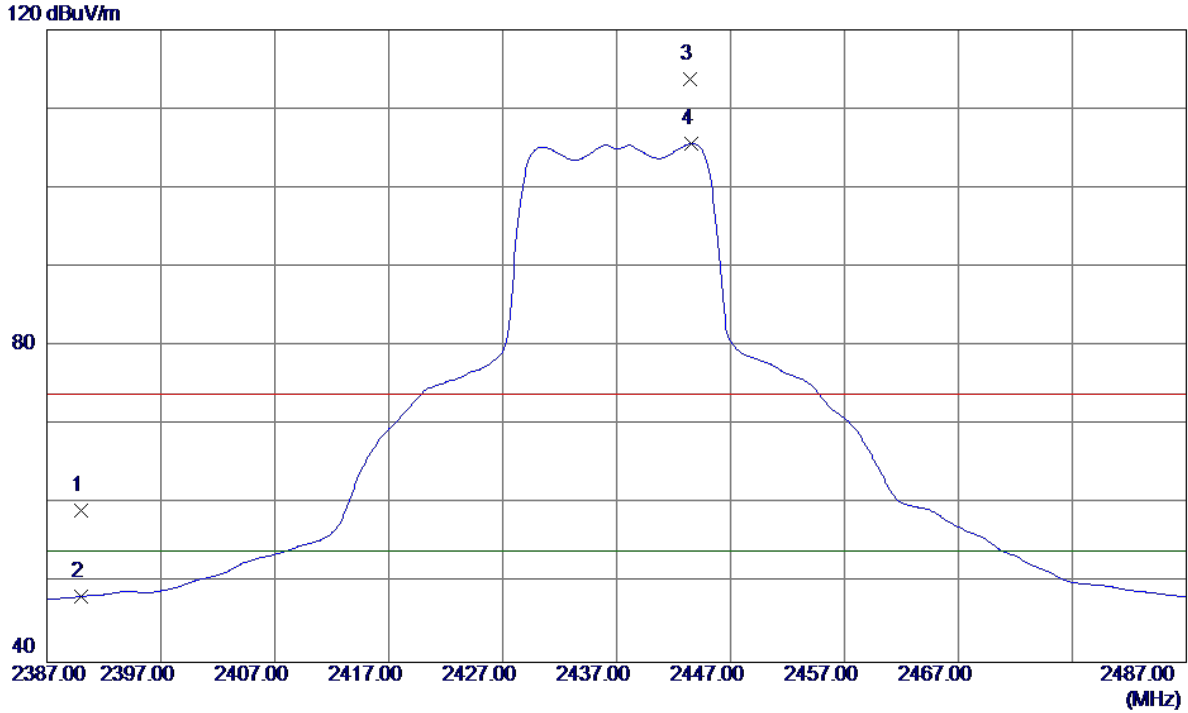

No.	Freq. MHz	Reading Level dBuV/m	Correct Factor dB	Measure ment dBuV/m	Limit dBuV/m	Margin dB	Detector	Comment
1	2390.0000	26.12	33.01	59.13	74.00	-14.87	Peak	
2	2390.0000	15.32	33.01	48.33	54.00	-5.67	AVG	
3	2443.4500	80.55	33.23	113.78	74.00	39.78	Peak	No Limit
4 *	2443.6000	72.34	33.23	105.57	54.00	51.57	AVG	No Limit

Orthogonal Axis :	X
Test Mode :	TX G MODE 2437MHz

**Vertical**

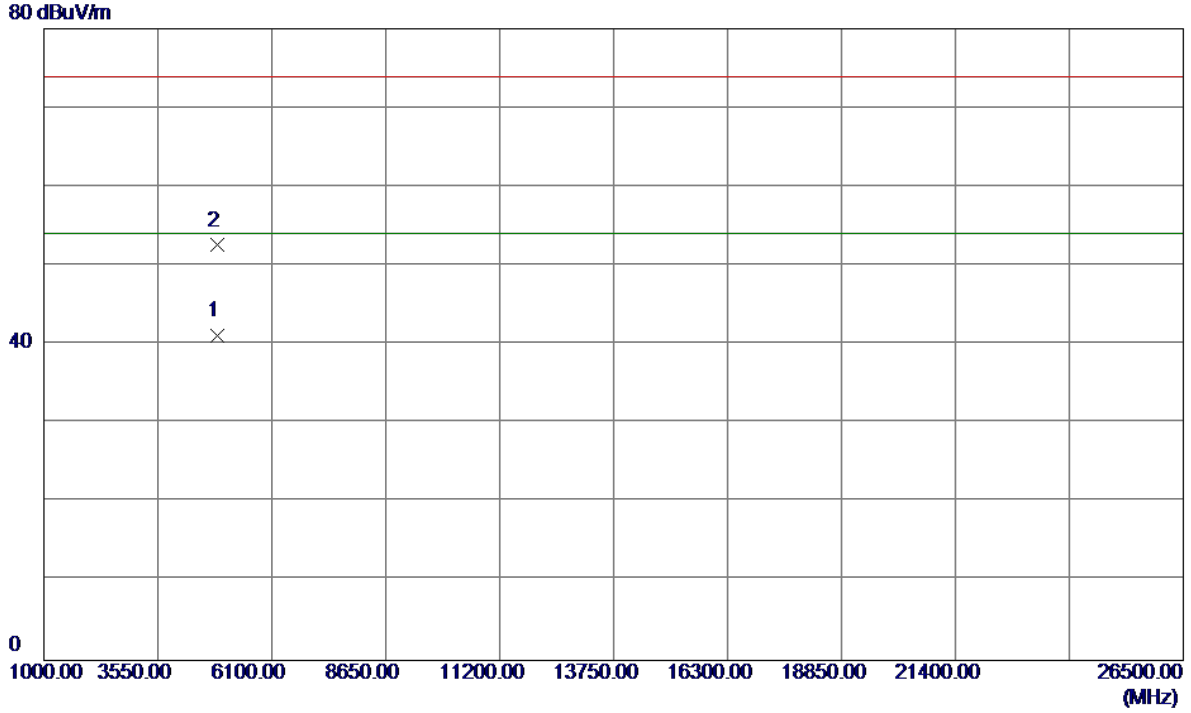

No.	Freq. MHz	Reading Level dBuV/m	Correct Factor dB	Measure ment dBuV/m	Limit dBuV/m	Margin dB	Detector	Comment
1 *	4874.3000	36.06	5.07	41.13	54.00	-12.87	AVG	
2	4874.8500	47.49	5.07	52.56	74.00	-21.44	Peak	

Orthogonal Axis :	X
Test Mode :	TX G MODE 2437MHz

**Horizontal**

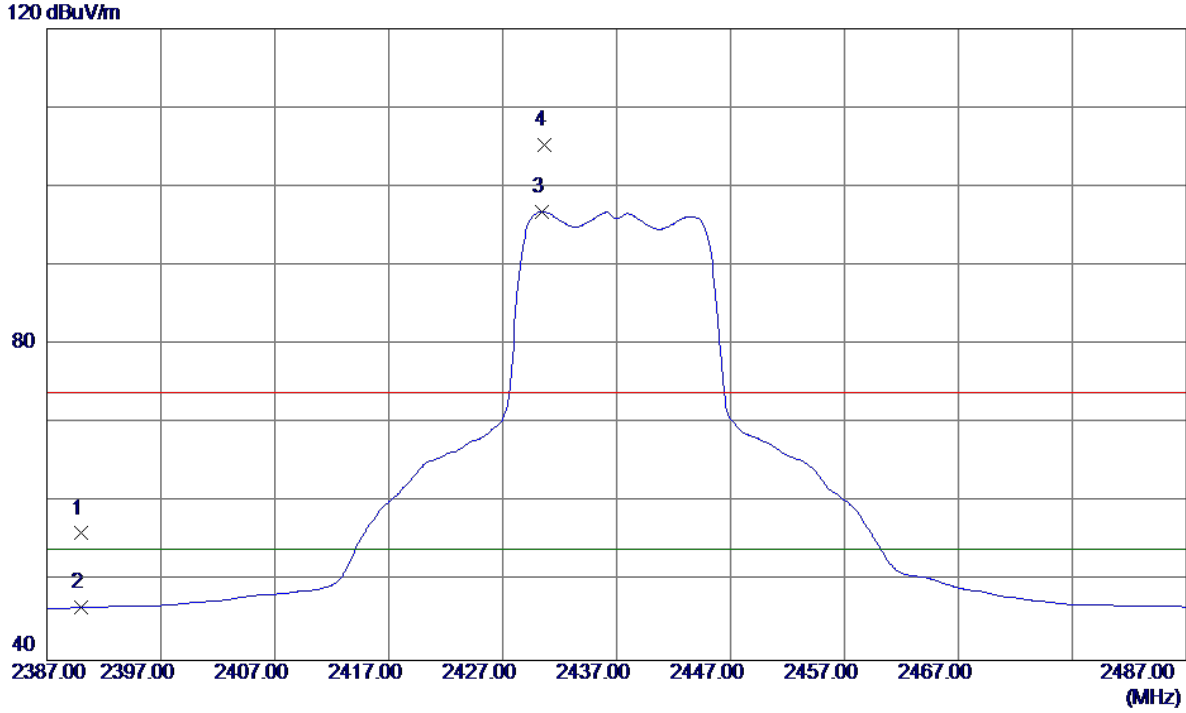

No.	Freq. MHz	Reading Level dBuV/m	Correct Factor dB	Measure ment dBuV/m	Limit dBuV/m	Margin dB	Detector	Comment
1	2390.0000	23.07	33.01	56.08	74.00	-17.92	Peak	
2	2390.0000	13.69	33.01	46.70	54.00	-7.30	AVG	
3 *	2430.4000	63.63	33.18	96.81	54.00	42.81	AVG	No Limit
4	2430.6500	72.10	33.18	105.28	74.00	31.28	Peak	No Limit

Orthogonal Axis :	X
Test Mode :	TX G MODE 2437MHz

**Horizontal**

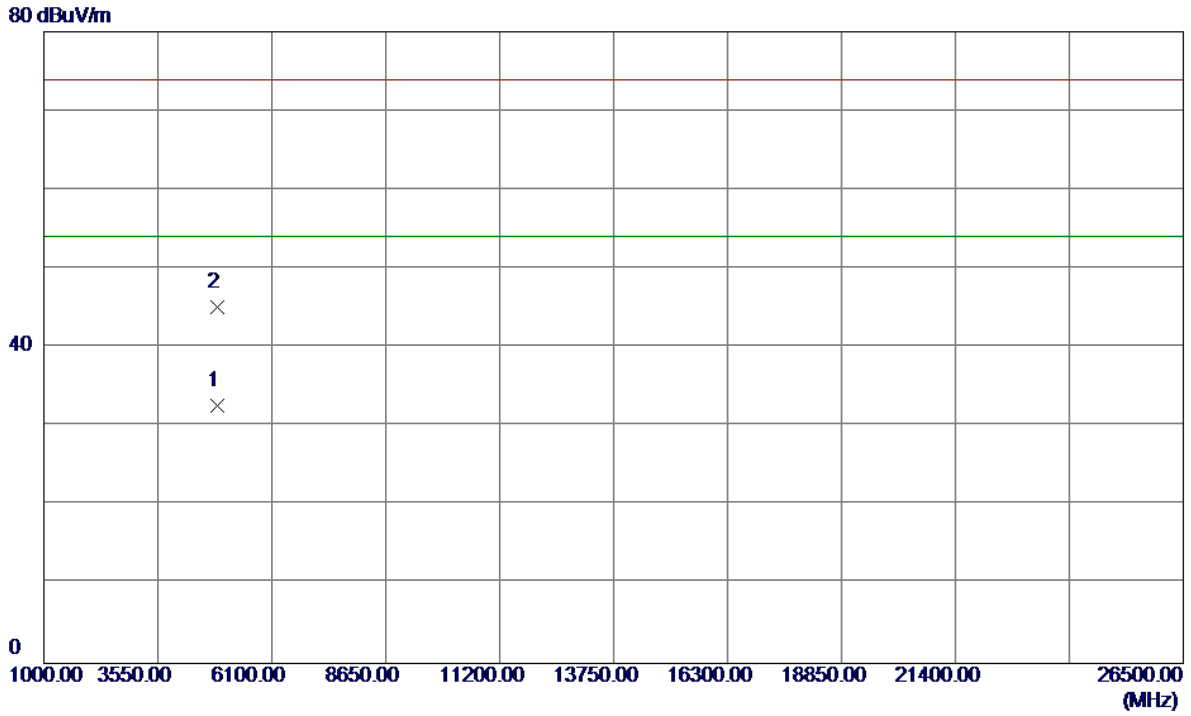

No.	Freq. MHz	Reading Level dBuV/m	Correct Factor dB	Measure ment dBuV/m	Limit dBuV/m	Margin dB	Detector	Comment
1 *	4874.3500	27.64	5.07	32.71	54.00	-21.29	AVG	
2	4875.2500	40.03	5.07	45.10	74.00	-28.90	Peak	

Orthogonal Axis :	X
Test Mode :	TX G MODE 2462MHz

**Vertical**

120 dBuV/m

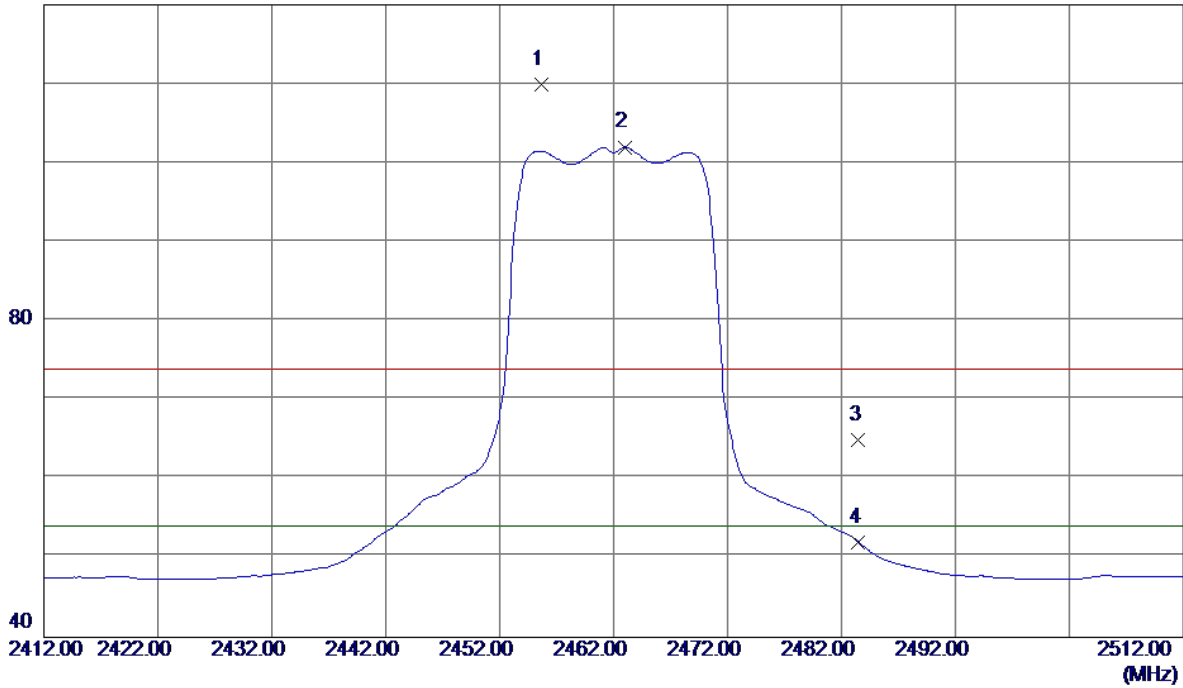

No.	Freq. MHz	Reading Level dBuV/m	Correct Factor dB	Measure ment dBuV/m	Limit dBuV/m	Margin dB	Detector	Comment
1	2455.6500	76.61	33.28	109.89	74.00	35.89	Peak	No Limit
2 *	2462.9500	68.68	33.32	102.00	54.00	48.00	AVG	No Limit
3	2483.5000	31.51	33.40	64.91	74.00	-9.09	Peak	
4	2483.5000	18.64	33.40	52.04	54.00	-1.96	AVG	

Orthogonal Axis :	X
Test Mode :	TX G MODE 2462MHz

**Vertical**

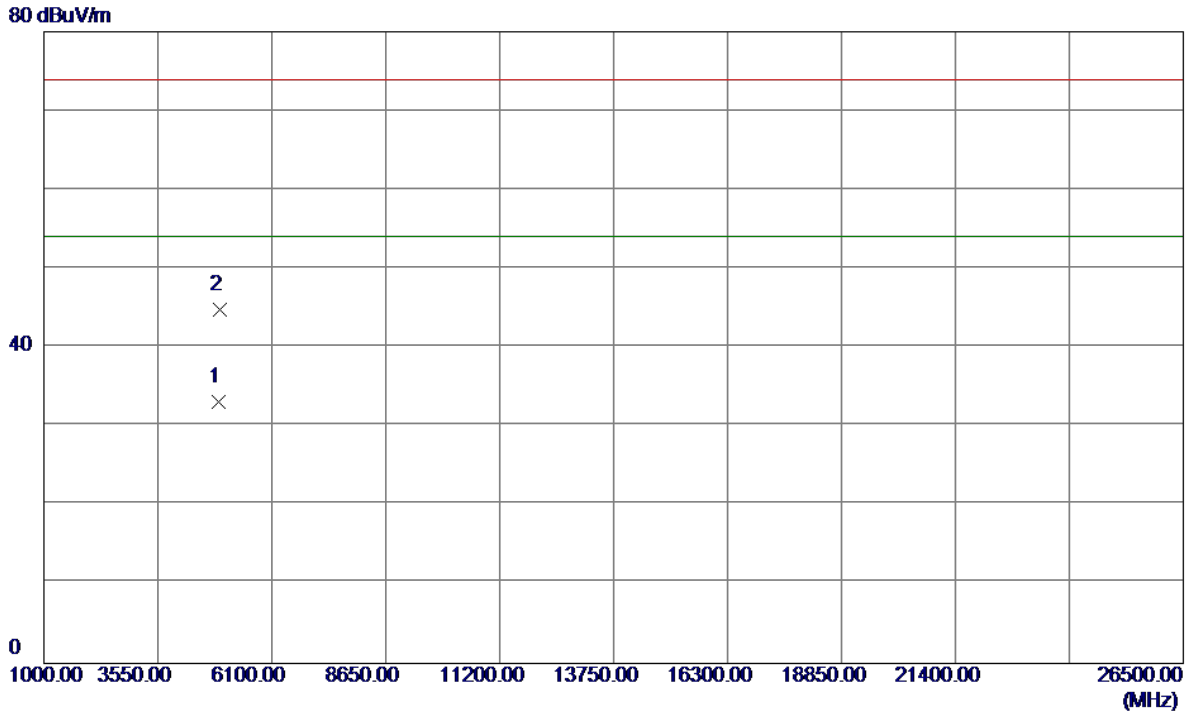

No.	Freq. MHz	Reading Level dBuV/m	Correct Factor dB	Measure ment dBuV/m	Limit dBuV/m	Margin dB	Detector	Comment
1 *	4924.0000	27.88	5.28	33.16	54.00	-20.84	AVG	
2	4926.9000	39.53	5.29	44.82	74.00	-29.18	Peak	

Orthogonal Axis :	X
Test Mode :	TX G MODE 2462MHz

**Horizontal**

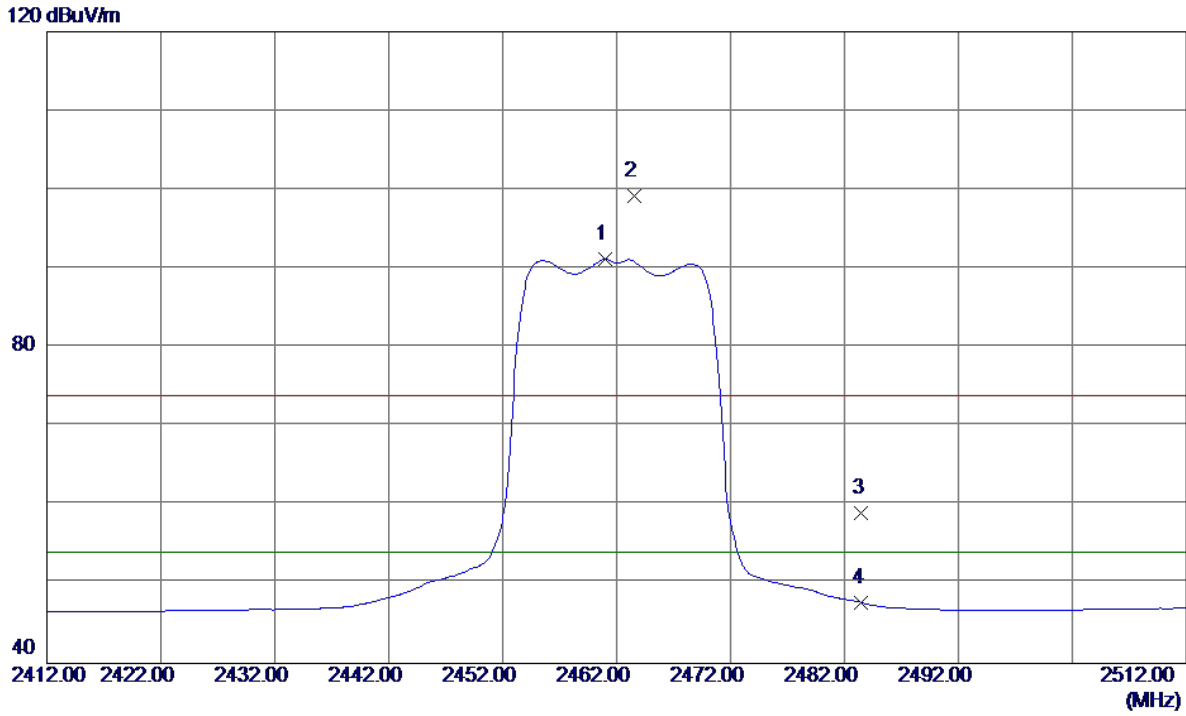

No.	Freq. MHz	Reading Level dBuV/m	Correct Factor dB	Measure ment dBuV/m	Limit dBuV/m	Margin dB	Detector	Comment
1 *	2461.0000	57.93	33.31	91.24	54.00	37.24	AVG	No Limit
2	2463.6000	65.87	33.32	99.19	74.00	25.19	Peak	No Limit
3	2483.5000	25.70	33.40	59.10	74.00	-14.90	Peak	
4	2483.5000	14.29	33.40	47.69	54.00	-6.31	AVG	

Orthogonal Axis :	X
Test Mode :	TX G MODE 2462MHz

**Horizontal**



No.	Freq. MHz	Reading Level dBuV/m	Correct Factor dB	Measure ment dBuV/m	Limit dBuV/m	Margin dB	Detector	Comment
1	4923.7000	33.15	5.28	38.43	74.00	-35.57	Peak	
2 *	4925.2000	22.71	5.28	27.99	54.00	-26.01	AVG	

Orthogonal Axis :	X
Test Mode :	TX N-20M MODE 2412MHz

**Vertical**

120 dBuV/m

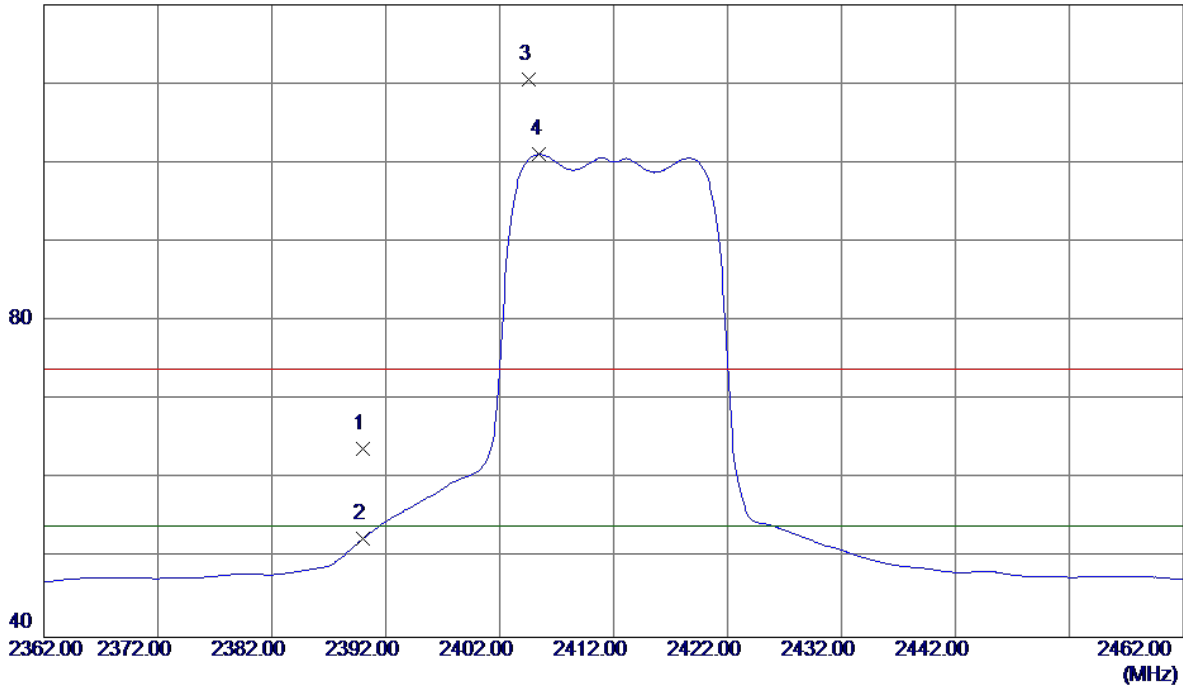

No.	Freq. MHz	Reading Level dBuV/m	Correct Factor dB	Measure ment dBuV/m	Limit dBuV/m	Margin dB	Detector	Comment
1	2390.0000	30.87	33.01	63.88	74.00	-10.12	Peak	
2	2390.0000	19.46	33.01	52.47	54.00	-1.53	AVG	
3	2404.6000	77.41	33.07	110.48	74.00	36.48	Peak	No Limit
4 *	2405.5000	68.00	33.07	101.07	54.00	47.07	AVG	No Limit

Orthogonal Axis :	X
Test Mode :	TX N-20M MODE 2412MHz

**Vertical**

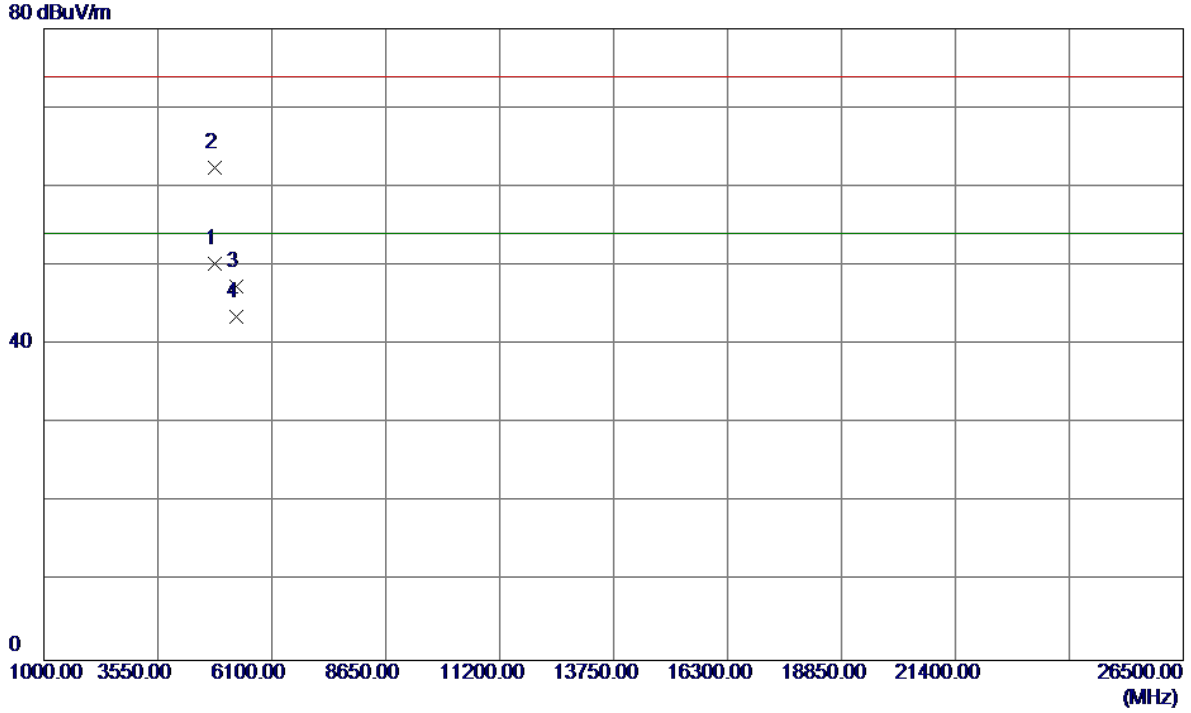

No.	Freq. MHz	Reading Level dBuV/m	Correct Factor dB	Measure ment dBuV/m	Limit dBuV/m	Margin dB	Detector	Comment
1 *	4823.8000	45.44	4.85	50.29	54.00	-3.71	AVG	
2	4824.9000	57.48	4.86	62.34	74.00	-11.66	Peak	
3	5299.9800	40.79	6.58	47.37	74.00	-26.63	Peak	
4	5299.9800	36.93	6.58	43.51	54.00	-10.49	AVG	

Orthogonal Axis :	X
Test Mode :	TX N-20M MODE 2412MHz

**Horizontal**

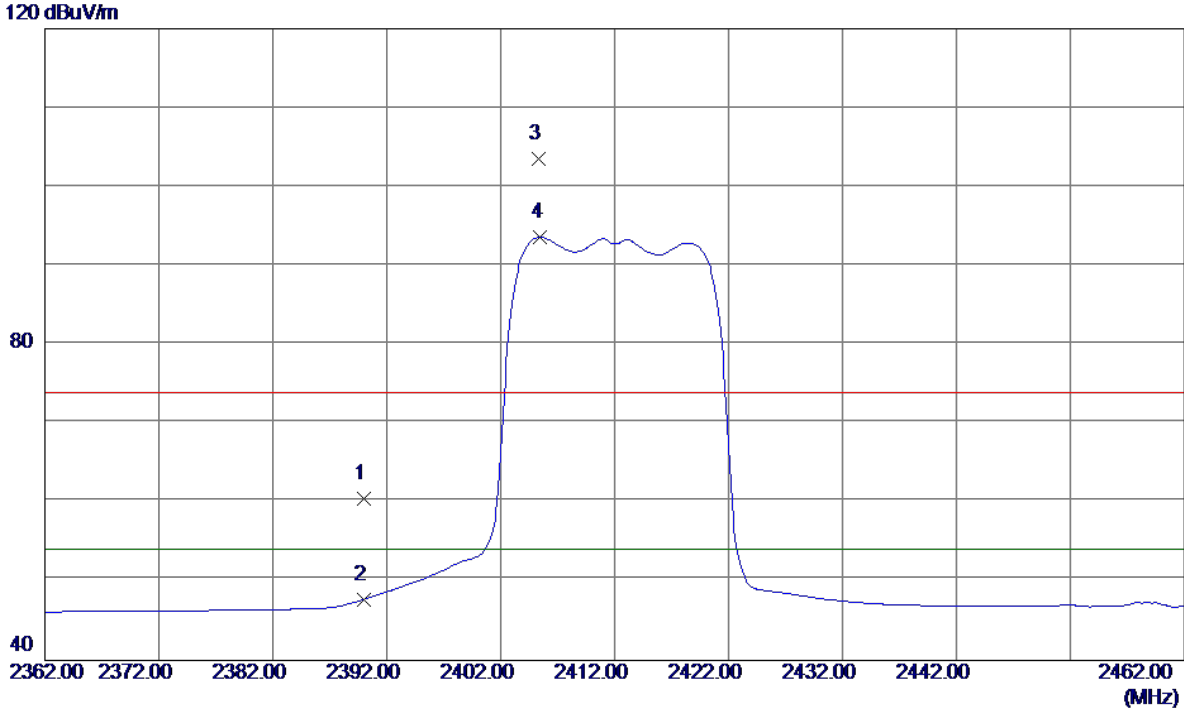

No.	Freq. MHz	Reading Level dBuV/m	Correct Factor dB	Measurement dBuV/m	Limit dBuV/m	Margin dB	Detector	Comment
1	2390.0000	27.51	33.01	60.52	74.00	-13.48	Peak	
2	2390.0000	14.73	33.01	47.74	54.00	-6.26	AVG	
3	2405.3000	70.39	33.07	103.46	74.00	29.46	Peak	No Limit
4 *	2405.5000	60.52	33.07	93.59	54.00	39.59	AVG	No Limit

Orthogonal Axis :	X
Test Mode :	TX N-20M MODE 2412MHz

**Horizontal**

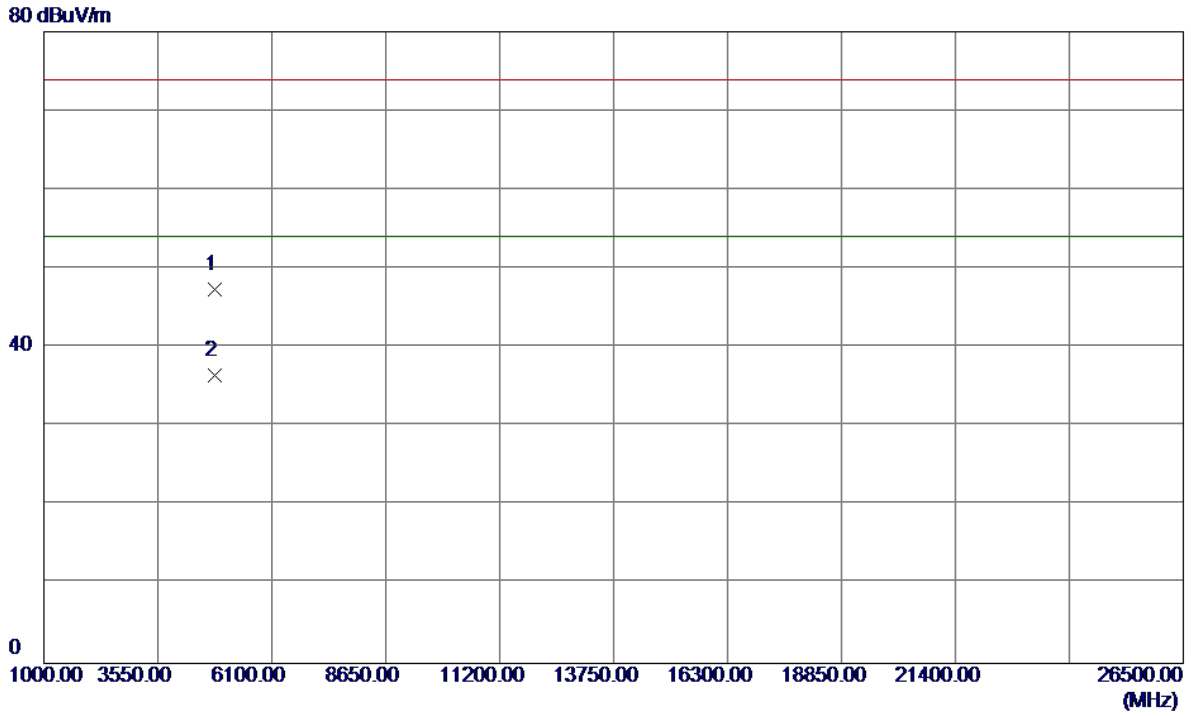

No.	Freq. MHz	Reading Level dBuV/m	Correct Factor dB	Measure ment dBuV/m	Limit dBuV/m	Margin dB	Detector	Comment
1	4823.4000	42.57	4.85	47.42	74.00	-26.58	Peak	
2 *	4823.8000	31.63	4.85	36.48	54.00	-17.52	AVG	

Orthogonal Axis :	X
Test Mode :	TX N-20M MODE 2437MHz

**Vertical**

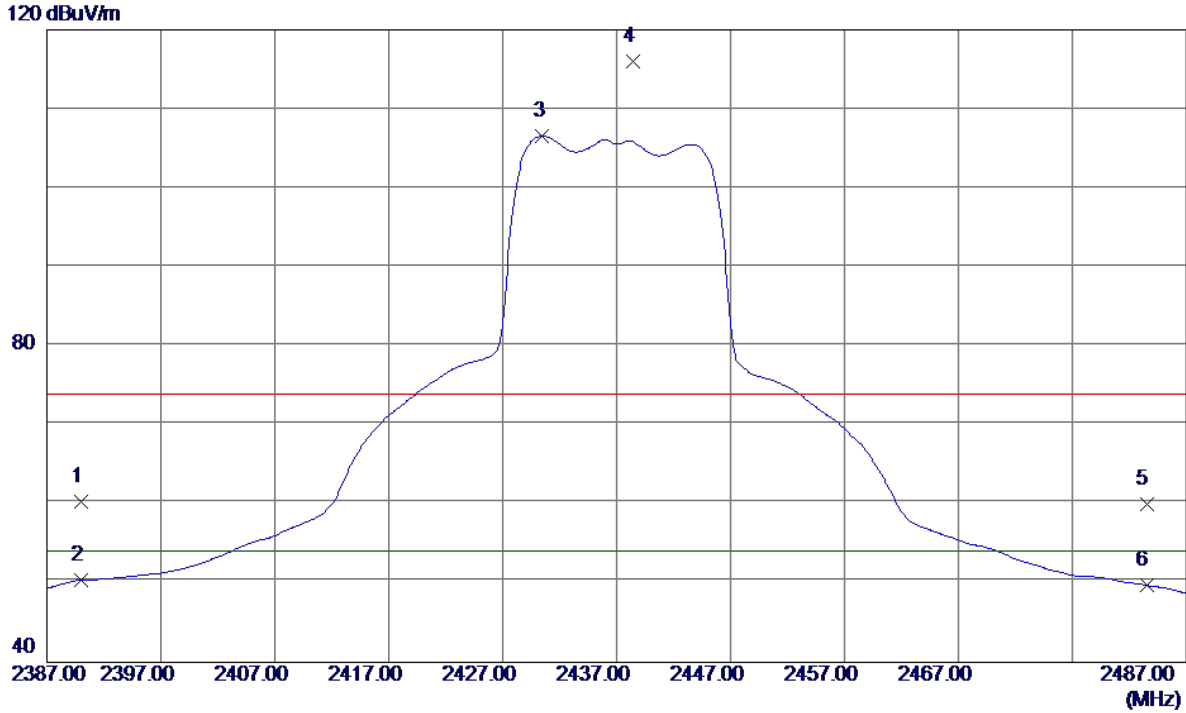

No.	Freq. MHz	Reading Level dBuV/m	Correct Factor dB	Measure ment dBuV/m	Limit dBuV/m	Margin dB	Detector	Comment
1	2390.0000	27.34	33.01	60.35	74.00	-13.65	Peak	
2	2390.0000	17.38	33.01	50.39	54.00	-3.61	AVG	
3 *	2430.5000	73.38	33.18	106.56	54.00	52.56	AVG	No Limit
4	2438.4000	82.74	33.21	115.95	74.00	41.95	Peak	No Limit
5	2483.5000	26.67	33.40	60.07	74.00	-13.93	Peak	
6	2483.5000	16.36	33.40	49.76	54.00	-4.24	AVG	

Orthogonal Axis :	X
Test Mode :	TX N-20M MODE 2437MHz

**Vertical**

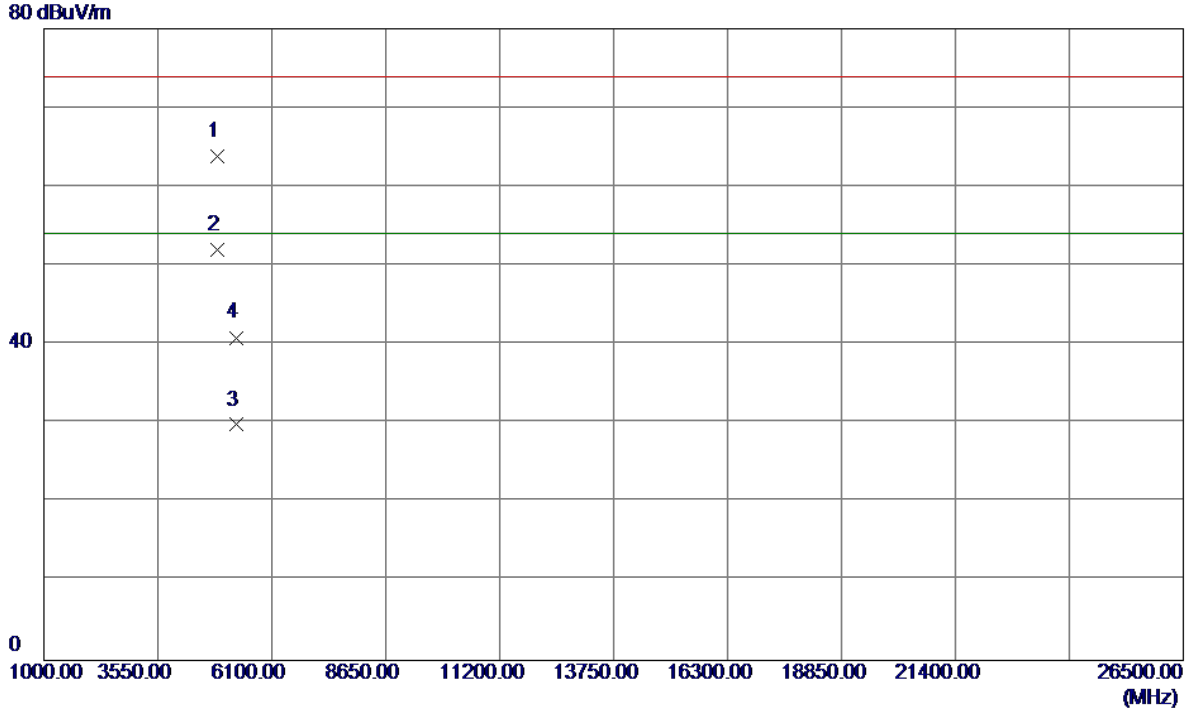

No.	Freq. MHz	Reading Level dBuV/m	Correct Factor dB	Measure ment dBuV/m	Limit dBuV/m	Margin dB	Detector	Comment
1	4873.1000	58.81	5.06	63.87	74.00	-10.13	Peak	
2 *	4873.7000	46.89	5.06	51.95	54.00	-2.05	AVG	
3	5299.9500	23.26	6.58	29.84	54.00	-24.16	AVG	
4	5299.9600	34.30	6.58	40.88	74.00	-33.12	Peak	

Orthogonal Axis :	X
Test Mode :	TX N-20M MODE 2437MHz

**Horizontal**

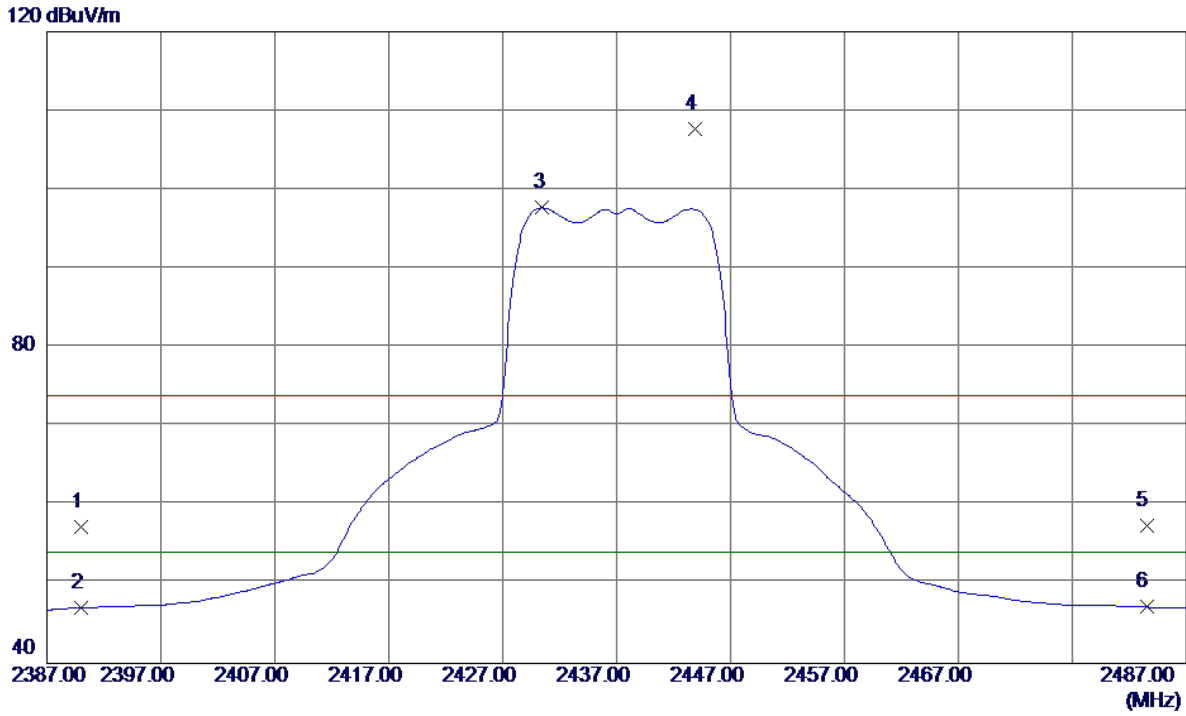

No.	Freq. MHz	Reading Level dBuV/m	Correct Factor dB	Measure ment dBuV/m	Limit dBuV/m	Margin dB	Detector	Comment
1	2390.0000	24.21	33.01	57.22	74.00	-16.78	Peak	
2	2390.0000	14.03	33.01	47.04	54.00	-6.96	AVG	
3 *	2430.5000	64.53	33.18	97.71	54.00	43.71	AVG	No Limit
4	2443.9000	74.44	33.24	107.68	74.00	33.68	Peak	No Limit
5	2483.5000	23.97	33.40	57.37	74.00	-16.63	Peak	
6	2483.5000	13.74	33.40	47.14	54.00	-6.86	AVG	

Orthogonal Axis :	X
Test Mode :	TX N-20M MODE 2437MHz

**Horizontal**

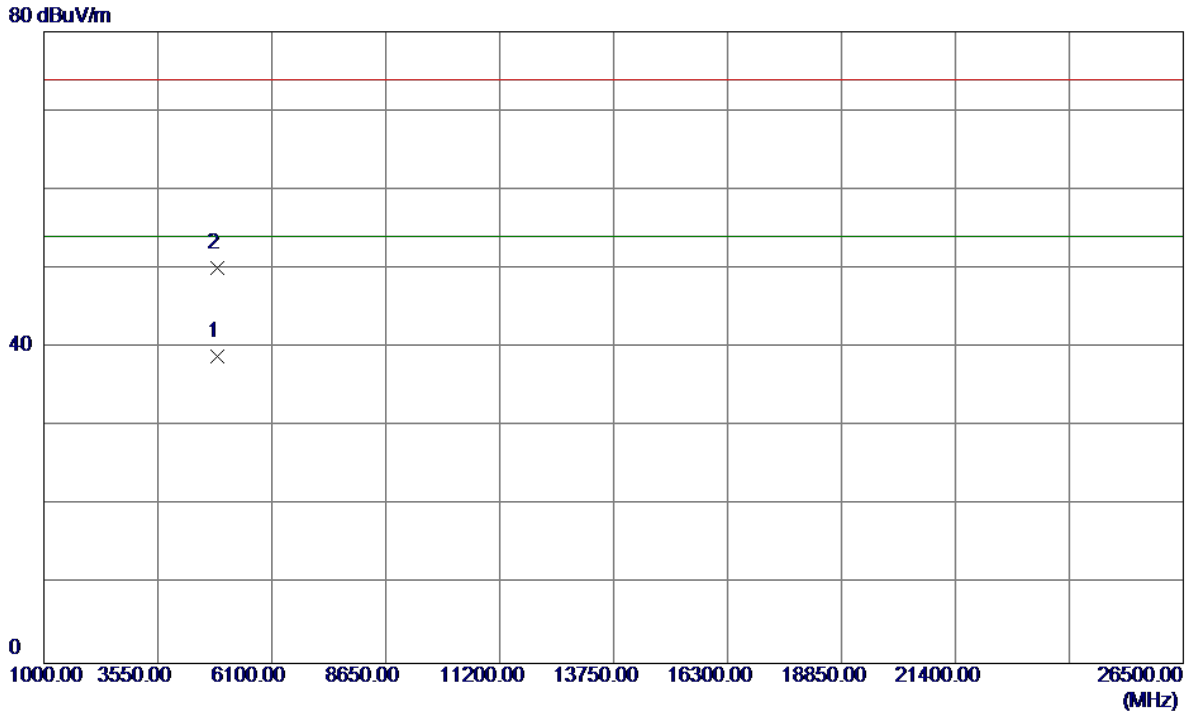

No.	Freq. MHz	Reading Level dBuV/m	Correct Factor dB	Measure ment dBuV/m	Limit dBuV/m	Margin dB	Detector	Comment
1 *	4874.2000	33.77	5.07	38.84	54.00	-15.16	AVG	
2	4874.4000	45.04	5.07	50.11	74.00	-23.89	Peak	

Orthogonal Axis :	X
Test Mode :	TX N-20M MODE 2462MHz

**Vertical**

120 dBuV/m

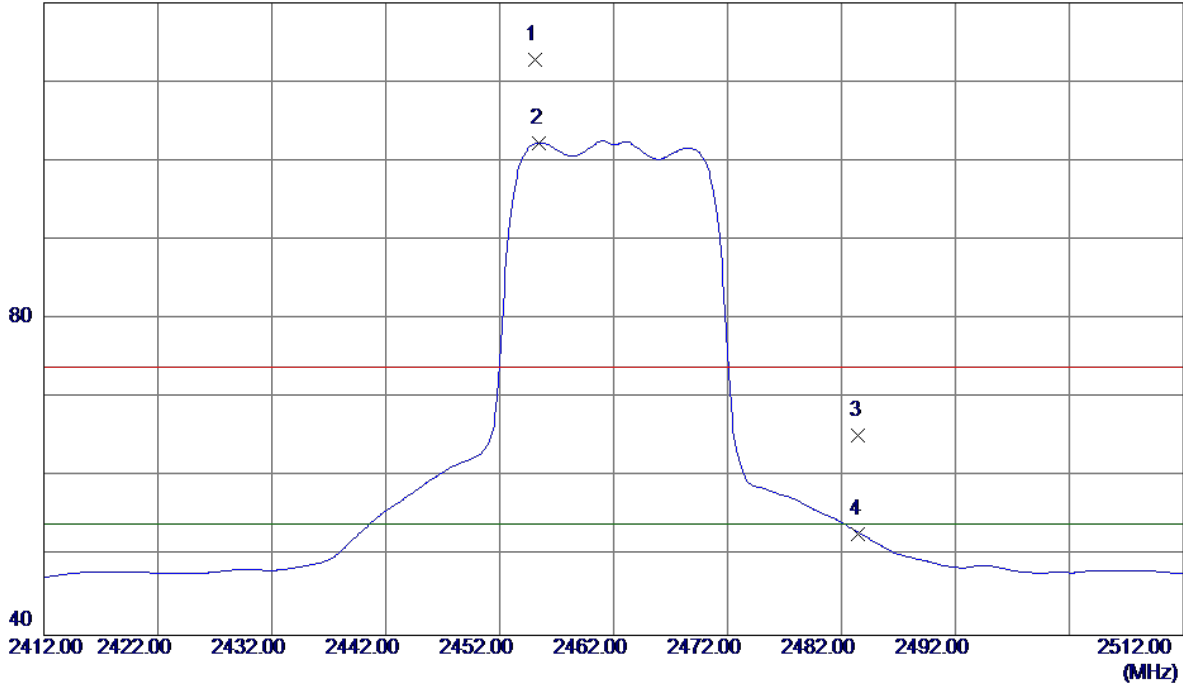

No.	Freq. MHz	Reading Level dBuV/m	Correct Factor dB	Measure ment dBuV/m	Limit dBuV/m	Margin dB	Detector	Comment
1	2455.1000	79.60	33.28	112.88	74.00	38.88	Peak	No Limit
2 *	2455.5000	69.01	33.28	102.29	54.00	48.29	AVG	No Limit
3	2483.5000	31.92	33.40	65.32	74.00	-8.68	Peak	
4	2483.5000	19.42	33.40	52.82	54.00	-1.18	AVG	

Orthogonal Axis :	X
Test Mode :	TX N-20M MODE 2462MHz

**Vertical**

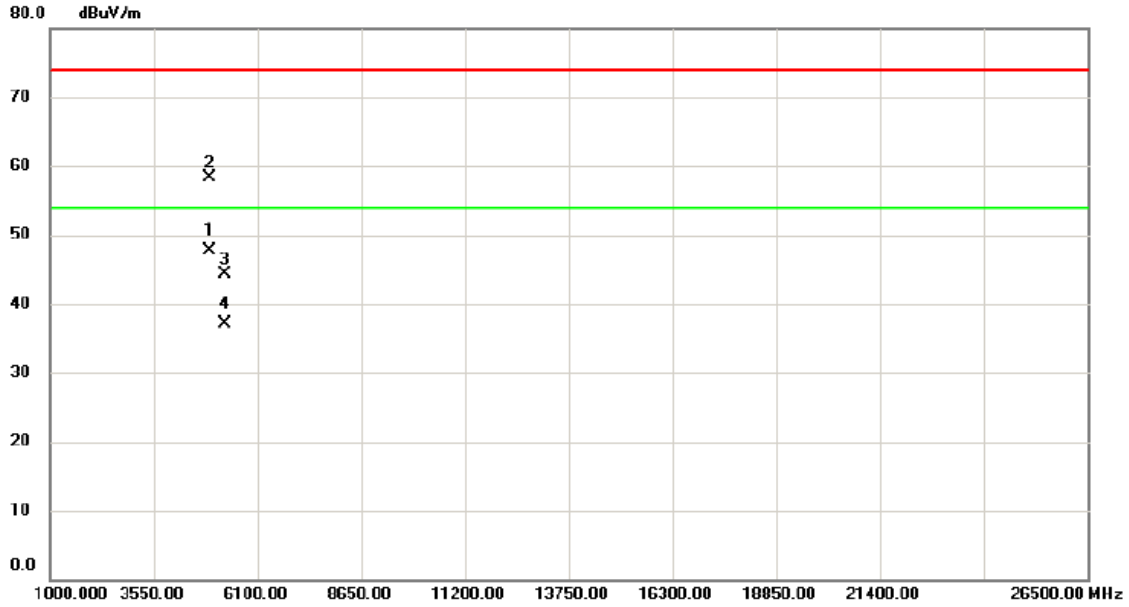

No.	Mk.	Freq. MHz	Reading Level dBuV	Correct Factor dB	Measure- ment dBuV/m	Limit dBuV/m	Margin dB	Detector	Comment
1	*	4923.600	42.38	5.27	47.65	54.00	-6.35	AVG	
2		4924.700	53.10	5.27	58.37	74.00	-15.63	peak	
3		5299.850	37.76	6.58	44.34	74.00	-29.66	peak	
4		5299.975	30.56	6.58	37.14	54.00	-16.86	AVG	

Orthogonal Axis :	X
Test Mode :	TX N-20M MODE 2462MHz

**Horizontal**

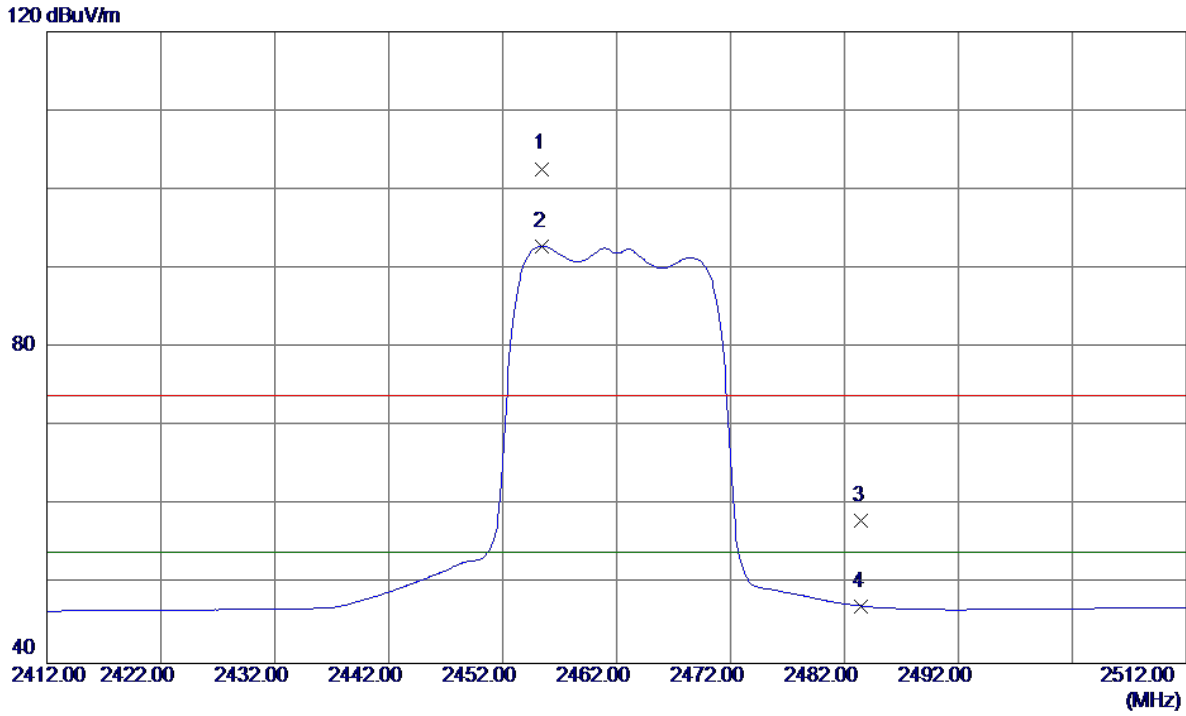

No.	Freq. MHz	Reading Level dBuV/m	Correct Factor dB	Measure ment dBuV/m	Limit dBuV/m	Margin dB	Detector	Comment
1	2455.5000	69.36	33.28	102.64	74.00	28.64	Peak	No Limit
2 *	2455.5000	59.59	33.28	92.87	54.00	38.87	AVG	No Limit
3	2483.5000	24.62	33.40	58.02	74.00	-15.98	Peak	
4	2483.5000	13.87	33.40	47.27	54.00	-6.73	AVG	

Orthogonal Axis :	X
Test Mode :	TX N-20M MODE 2462MHz

**Horizontal**

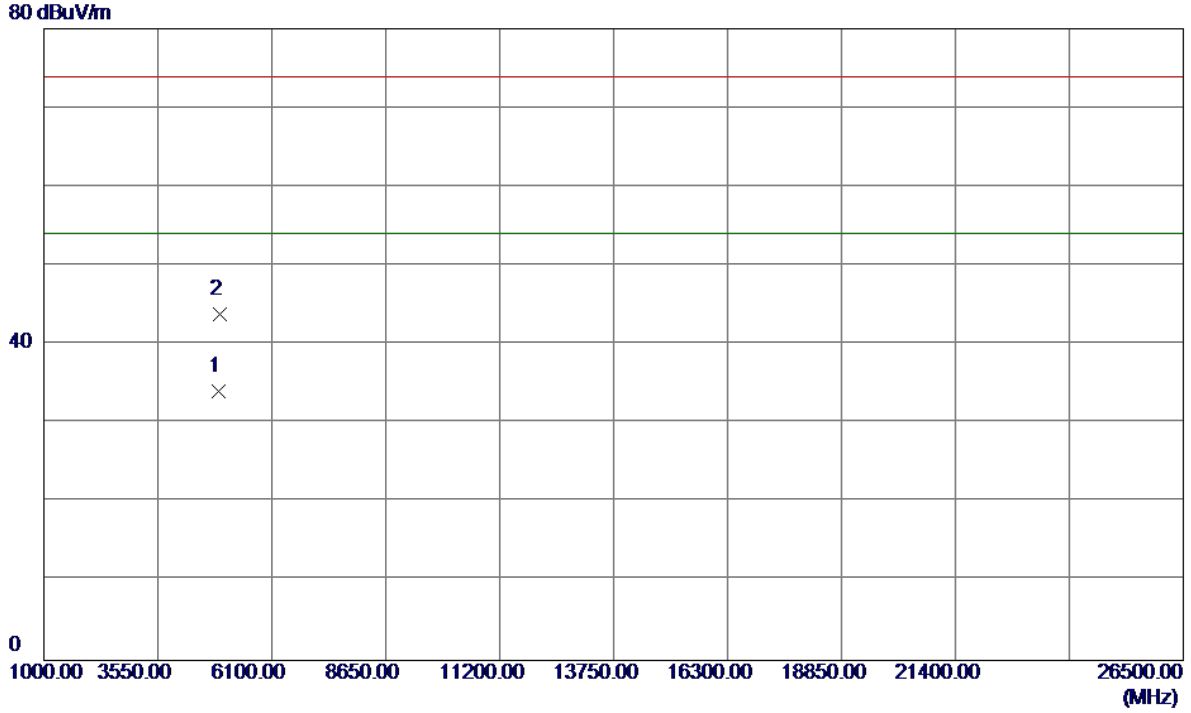

No.	Freq. MHz	Reading Level dBuV/m	Correct Factor dB	Measure ment dBuV/m	Limit dBuV/m	Margin dB	Detector	Comment
1 *	4923.0000	28.85	5.27	34.12	54.00	-19.88	AVG	
2	4924.2000	38.64	5.28	43.92	74.00	-30.08	Peak	

Orthogonal Axis :	X
Test Mode :	TX N-40M MODE 2422MHz

**Vertical**

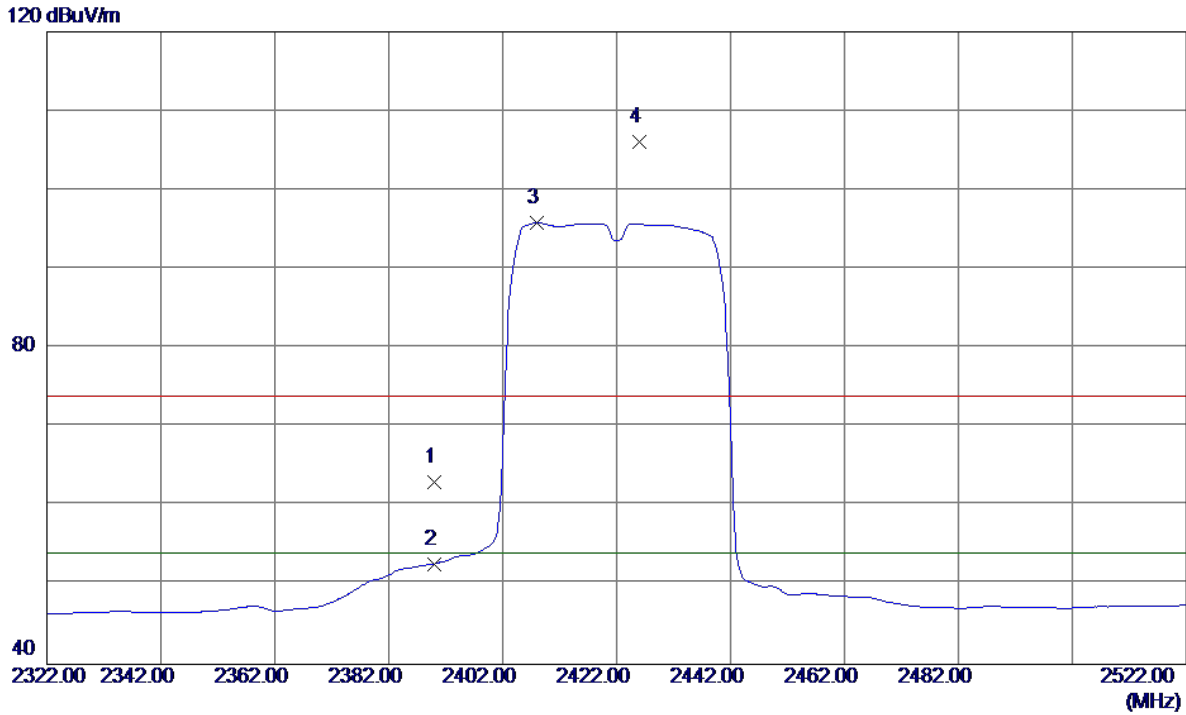

No.	Freq. MHz	Reading Level dBuV/m	Correct Factor dB	Measure ment dBuV/m	Limit dBuV/m	Margin dB	Detector	Comment
1	2390.0000	30.00	33.01	63.01	74.00	-10.99	Peak	
2	2390.0000	19.68	33.01	52.69	54.00	-1.31	AVG	
3 *	2408.0000	62.72	33.09	95.81	54.00	41.81	AVG	No Limit
4	2426.0000	72.97	33.16	106.13	74.00	32.13	Peak	No Limit

Orthogonal Axis :	X
Test Mode :	TX N-40M MODE 2422MHz

**Vertical**

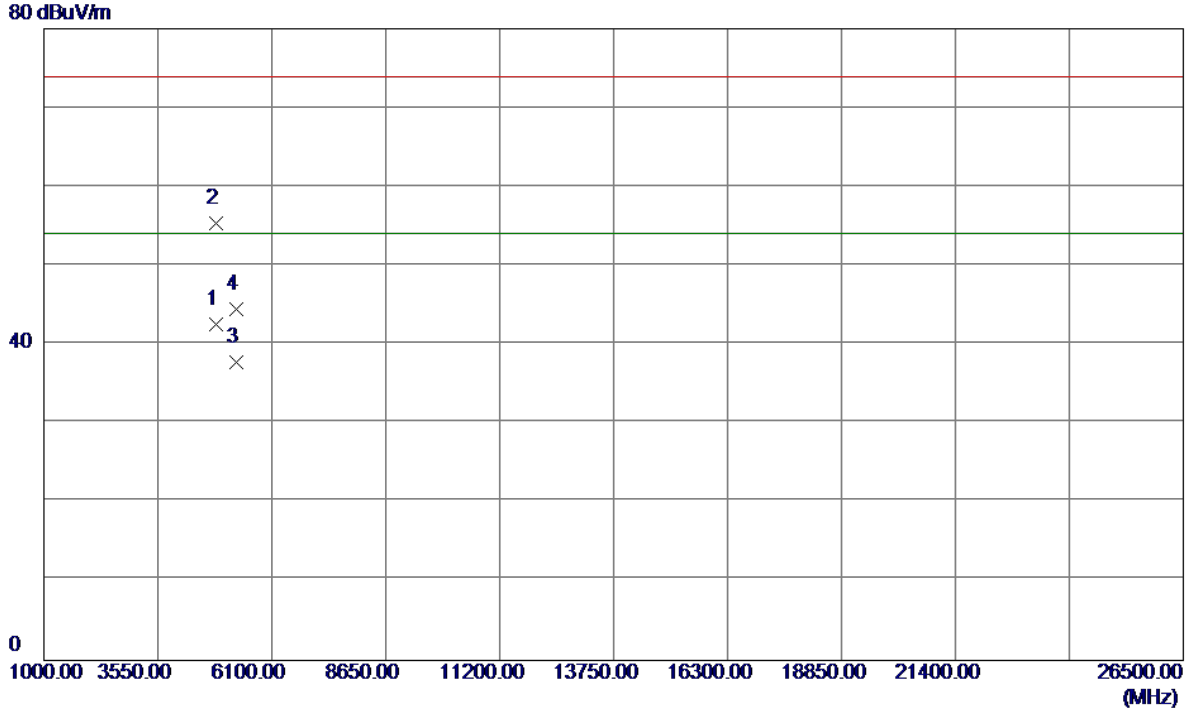

No.	Freq. MHz	Reading Level dBuV/m	Correct Factor dB	Measure ment dBuV/m	Limit dBuV/m	Margin dB	Detector	Comment
1 *	4840.2000	37.70	4.92	42.62	54.00	-11.38	AVG	
2	4844.8000	50.43	4.94	55.37	74.00	-18.63	Peak	
3	5299.9800	31.12	6.58	37.70	54.00	-16.30	AVG	
4	5299.9850	37.86	6.58	44.44	74.00	-29.56	Peak	

Orthogonal Axis :	X
Test Mode :	TX N-40M MODE 2422MHz

**Horizontal**

120 dBuV/m

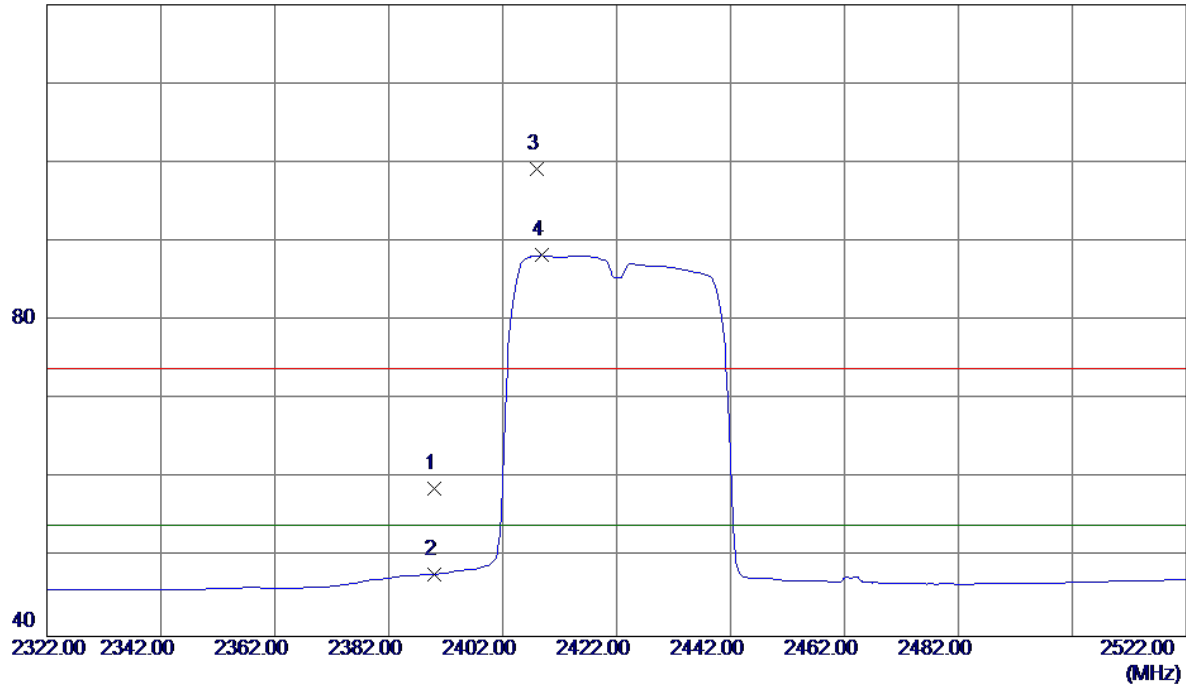

No.	Freq. MHz	Reading Level dBuV/m	Correct Factor dB	Measure ment dBuV/m	Limit dBuV/m	Margin dB	Detector	Comment
1	2390.0000	25.66	33.01	58.67	74.00	-15.33	Peak	
2	2390.0000	14.87	33.01	47.88	54.00	-6.12	AVG	
3	2408.0000	66.13	33.09	99.22	74.00	25.22	Peak	No Limit
4 *	2408.8000	55.16	33.09	88.25	54.00	34.25	AVG	No Limit

Orthogonal Axis :	X
Test Mode :	TX N-40M MODE 2422MHz

**Horizontal**

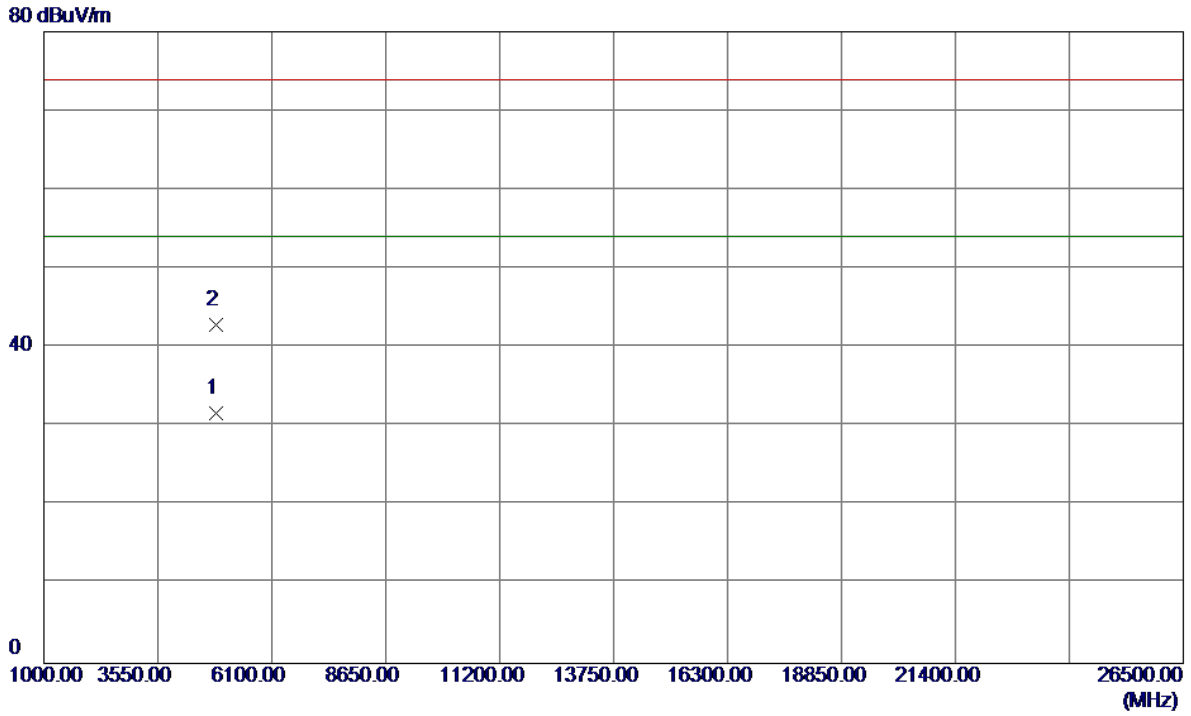

No.	Freq. MHz	Reading Level dBuV/m	Correct Factor dB	Measure ment dBuV/m	Limit dBuV/m	Margin dB	Detector	Comment
1 *	4848.6000	26.70	4.96	31.66	54.00	-22.34	AVG	
2	4848.8000	37.90	4.96	42.86	74.00	-31.14	Peak	

Orthogonal Axis :	X
Test Mode :	TX N-40M MODE 2437MHz

**Vertical**

120 dBuV/m

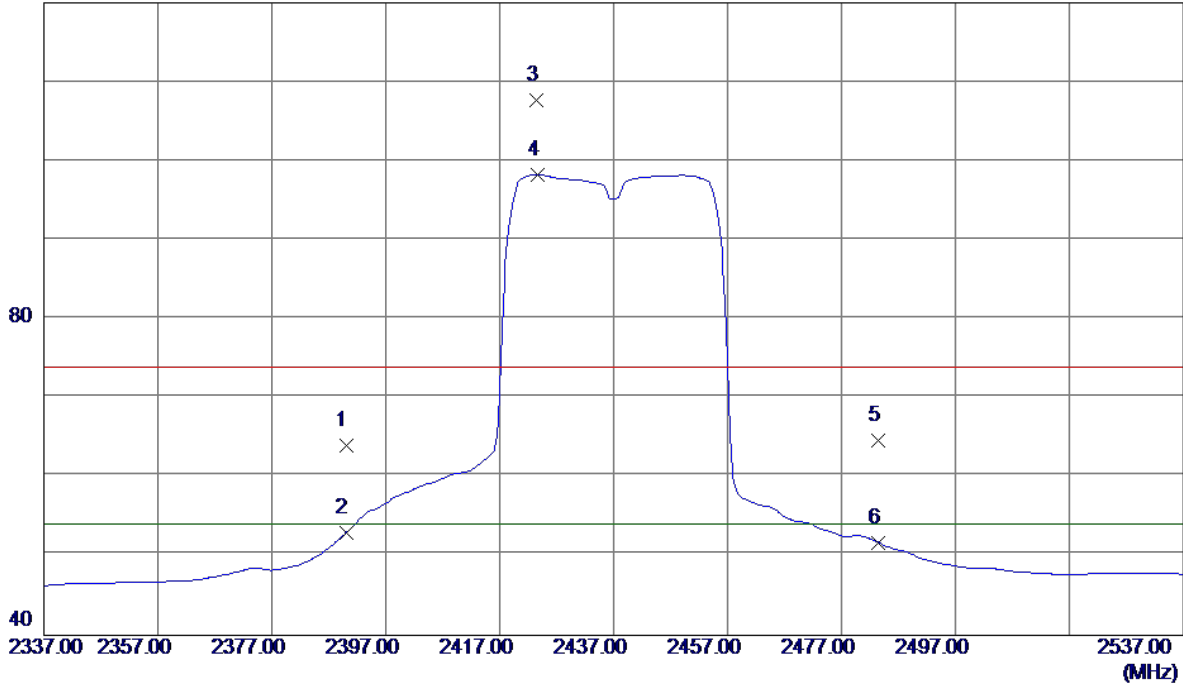

No.	Freq. MHz	Reading Level dBuV/m	Correct Factor dB	Measure ment dBuV/m	Limit dBuV/m	Margin dB	Detector	Comment
1	2390.0000	31.06	33.01	64.07	74.00	-9.93	Peak	
2	2390.0000	19.92	33.01	52.93	54.00	-1.07	AVG	
3	2423.4000	74.47	33.15	107.62	74.00	33.62	Peak	No Limit
4 *	2423.6000	65.13	33.15	98.28	54.00	44.28	AVG	No Limit
5	2483.5000	31.21	33.40	64.61	74.00	-9.39	Peak	
6	2483.5000	18.30	33.40	51.70	54.00	-2.30	AVG	

Orthogonal Axis :	X
Test Mode :	TX N-40M MODE 2437MHz

**Vertical**

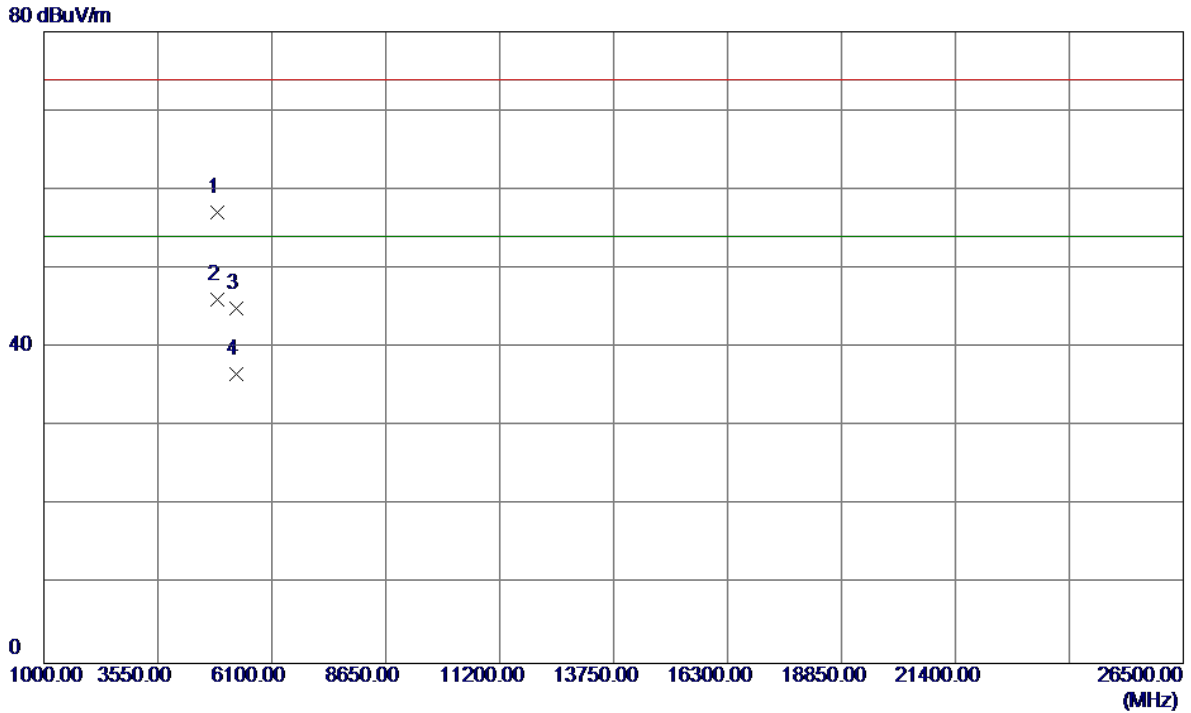

No.	Freq. MHz	Reading Level dBuV/m	Correct Factor dB	Measure ment dBuV/m	Limit dBuV/m	Margin dB	Detector	Comment
1	4870.2000	52.01	5.05	57.06	74.00	-16.94	Peak	
2 *	4870.4000	41.10	5.05	46.15	54.00	-7.85	AVG	
3	5299.8600	38.33	6.58	44.91	74.00	-29.09	Peak	
4	5299.9800	30.10	6.58	36.68	54.00	-17.32	AVG	

Orthogonal Axis :	X
Test Mode :	TX N-40M MODE 2437MHz

**Horizontal**

120 dBuV/m

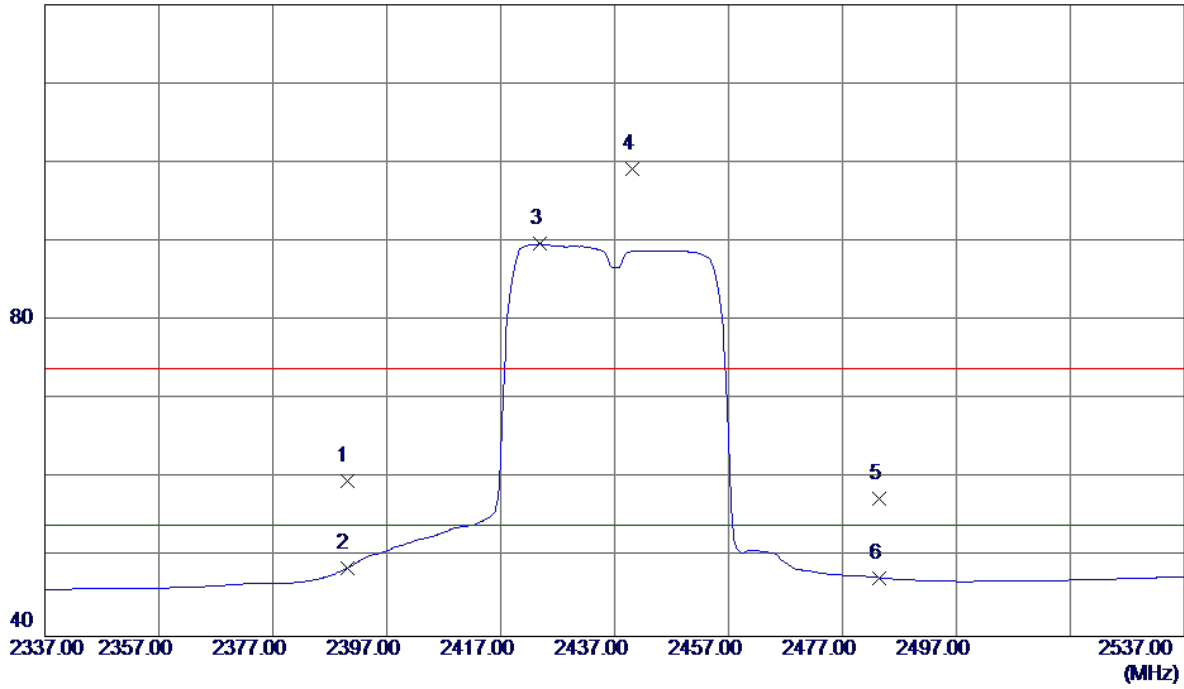

No.	Freq. MHz	Reading Level dBuV/m	Correct Factor dB	Measure ment dBuV/m	Limit dBuV/m	Margin dB	Detector	Comment
1	2390.0000	26.67	33.01	59.68	74.00	-14.32	Peak	
2	2390.0000	15.64	33.01	48.65	54.00	-5.35	AVG	
3 *	2423.8000	56.56	33.15	89.71	54.00	35.71	AVG	No Limit
4	2440.2000	65.90	33.22	99.12	74.00	25.12	Peak	No Limit
5	2483.5000	24.10	33.40	57.50	74.00	-16.50	Peak	
6	2483.5000	14.01	33.40	47.41	54.00	-6.59	AVG	

Orthogonal Axis :	X
Test Mode :	TX N-40M MODE 2437MHz

**Horizontal**

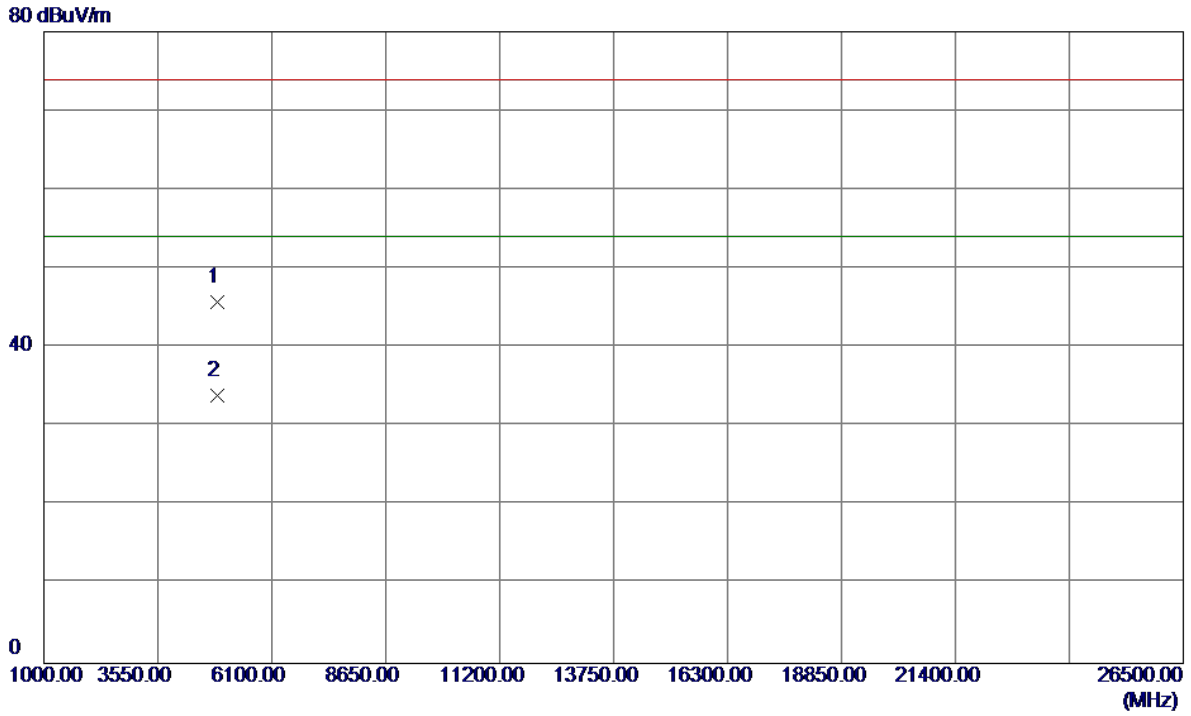

No.	Freq. MHz	Reading Level dBuV/m	Correct Factor dB	Measure ment dBuV/m	Limit dBuV/m	Margin dB	Detector	Comment
1	4873.8000	40.70	5.06	45.76	74.00	-28.24	Peak	
2 *	4876.2000	28.84	5.07	33.91	54.00	-20.09	AVG	

Orthogonal Axis :	X
Test Mode :	TX N-40M MODE 2452MHz

**Vertical**

120 dBuV/m

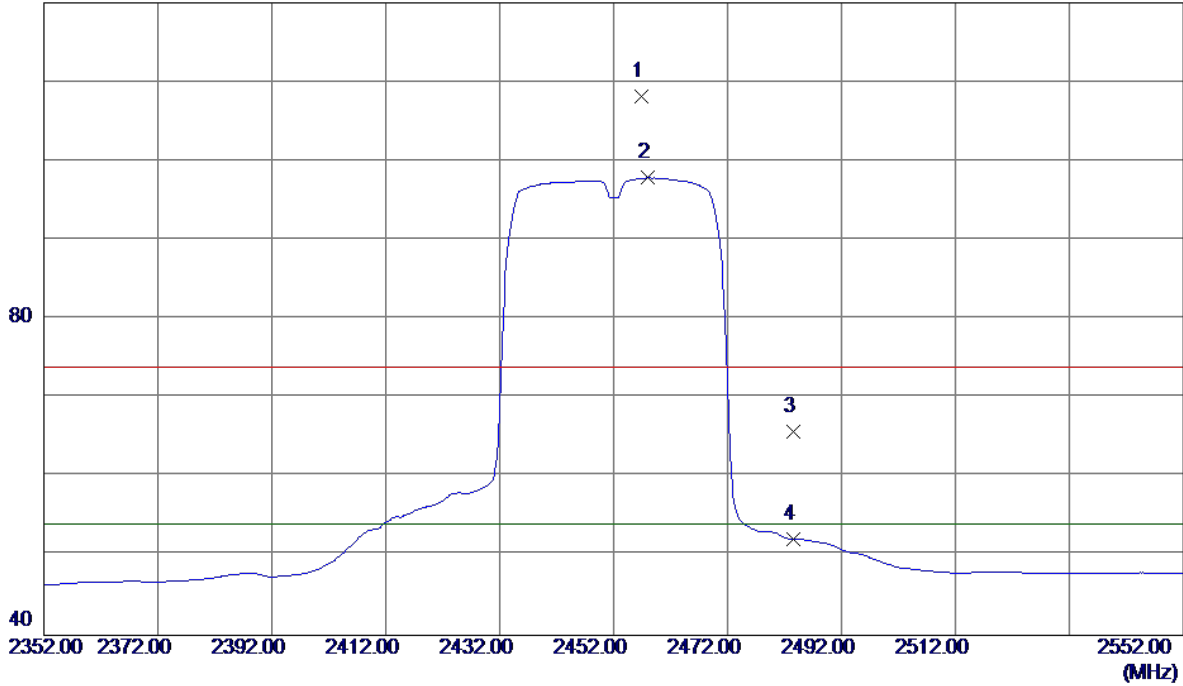

No.	Freq. MHz	Reading Level dBuV/m	Correct Factor dB	Measure ment dBuV/m	Limit dBuV/m	Margin dB	Detector	Comment
1	2456.8000	74.93	33.29	108.22	74.00	34.22	Peak	No Limit
2 *	2458.0000	64.57	33.29	97.86	54.00	43.86	AVG	No Limit
3	2483.5000	32.32	33.40	65.72	74.00	-8.28	Peak	
4	2483.5000	18.76	33.40	52.16	54.00	-1.84	AVG	

Orthogonal Axis :	X
Test Mode :	TX N-40M MODE 2452MHz

**Vertical**

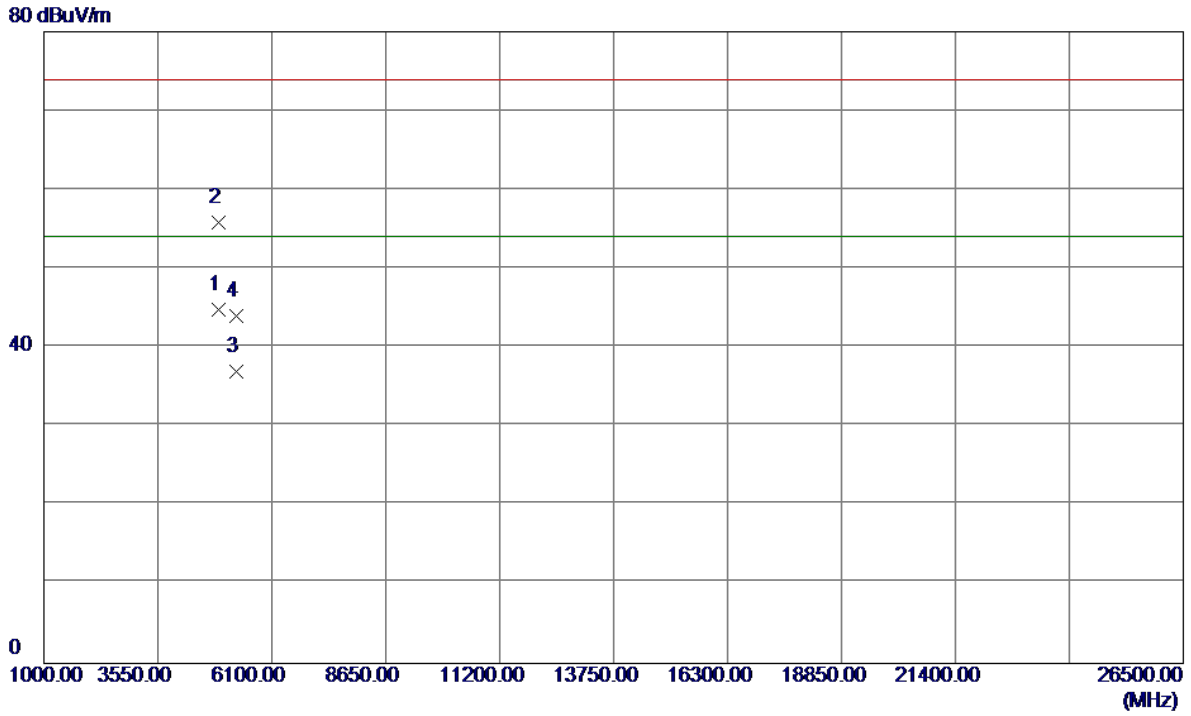

No.	Freq. MHz	Reading Level dBuV/m	Correct Factor dB	Measure ment dBuV/m	Limit dBuV/m	Margin dB	Detector	Comment
1 *	4900.6000	39.62	5.18	44.80	54.00	-9.20	AVG	
2	4902.2000	50.58	5.19	55.77	74.00	-18.23	Peak	
3	5299.9650	30.45	6.58	37.03	54.00	-16.97	AVG	
4	5300.0950	37.38	6.58	43.96	74.00	-30.04	Peak	

Orthogonal Axis :	X
Test Mode :	TX N-40M MODE 2452MHz

**Horizontal**

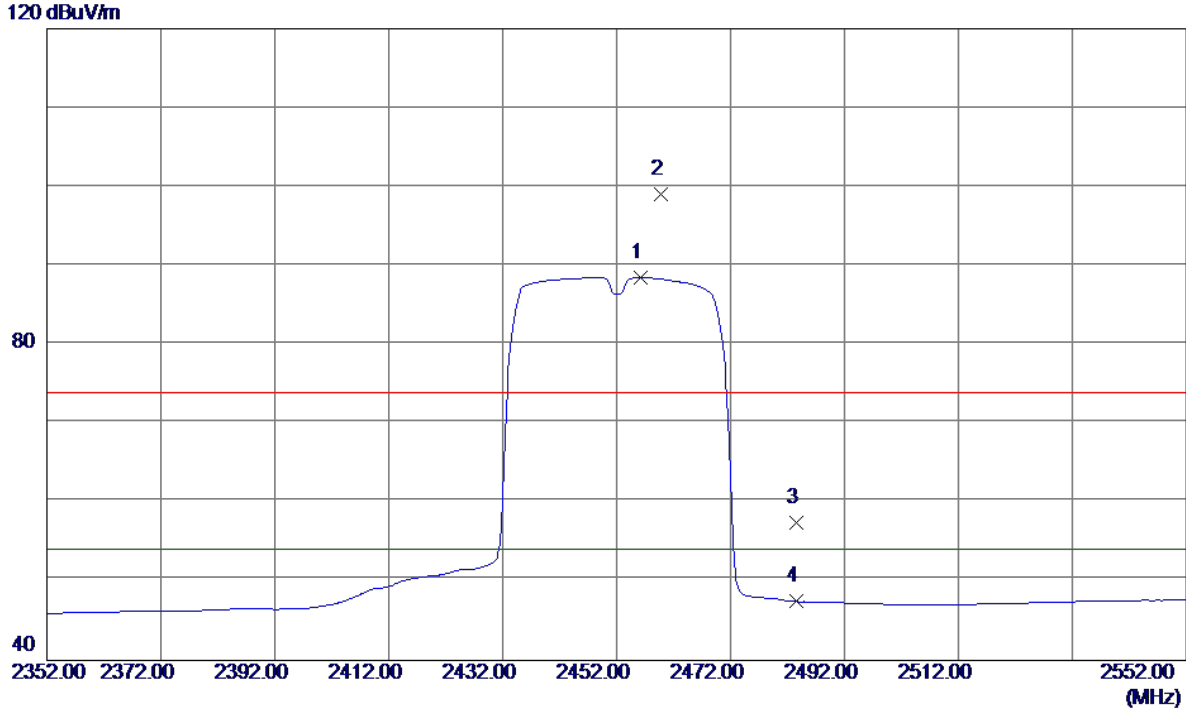

No.	Freq. MHz	Reading Level dBuV/m	Correct Factor dB	Measure ment dBuV/m	Limit dBuV/m	Margin dB	Detector	Comment
1 *	2456.2000	55.20	33.29	88.49	54.00	34.49	AVG	No Limit
2	2459.8000	65.77	33.30	99.07	74.00	25.07	Peak	No Limit
3	2483.5000	24.05	33.40	57.45	74.00	-16.55	Peak	
4	2483.5000	14.06	33.40	47.46	54.00	-6.54	AVG	

Orthogonal Axis :	X
Test Mode :	TX N-40M MODE 2452MHz

**Horizontal**

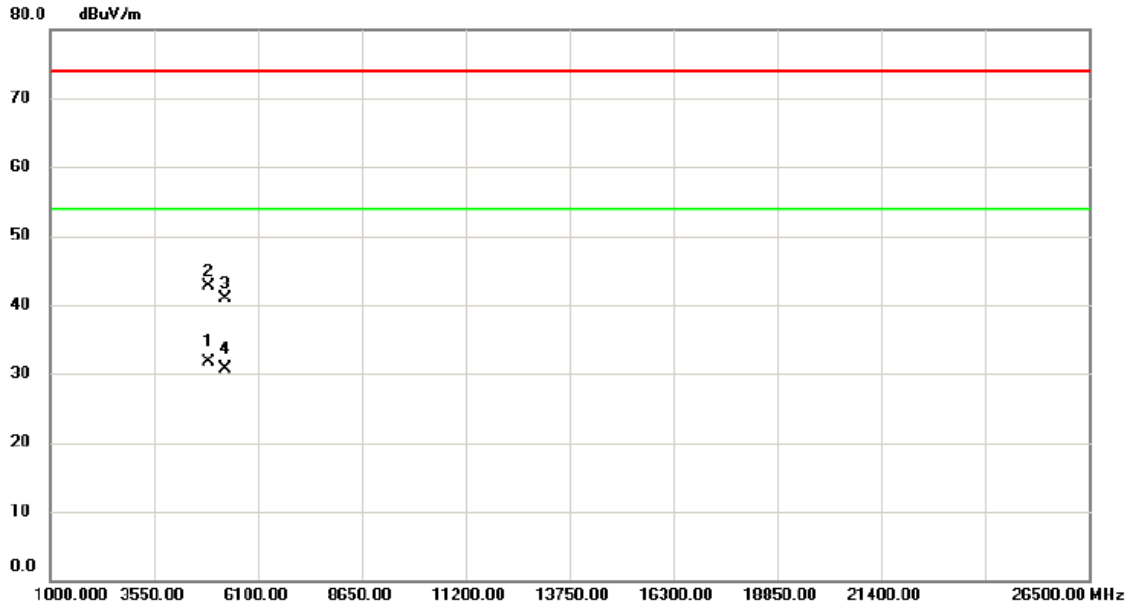

No.	Mk.	Freq. MHz	Reading Level dBuV	Correct Factor dB	Measure- ment dBuV/m	Limit dBuV/m	Margin dB	Detector	Comment
1	*	4903.200	26.53	5.19	31.72	54.00	-22.28	AVG	
2		4904.800	37.54	5.20	42.74	74.00	-31.26	peak	
3		5299.740	34.31	6.58	40.89	74.00	-33.11	peak	
4		5300.000	24.10	6.58	30.68	54.00	-23.32	AVG	

## ATTACHMENT E - BANDWIDTH

**Test Mode : TX B Mode\_CH01/06/11**

Frequency (MHz)	6dB Bandwidth (MHz)	99% Occupied BW (MHz)	Min. Limit (kHz)	Test Result
2412	10.10	14.64	500	Complies
2437	10.10	14.72	500	Complies
2462	10.10	14.68	500	Complies

**TX CH01**

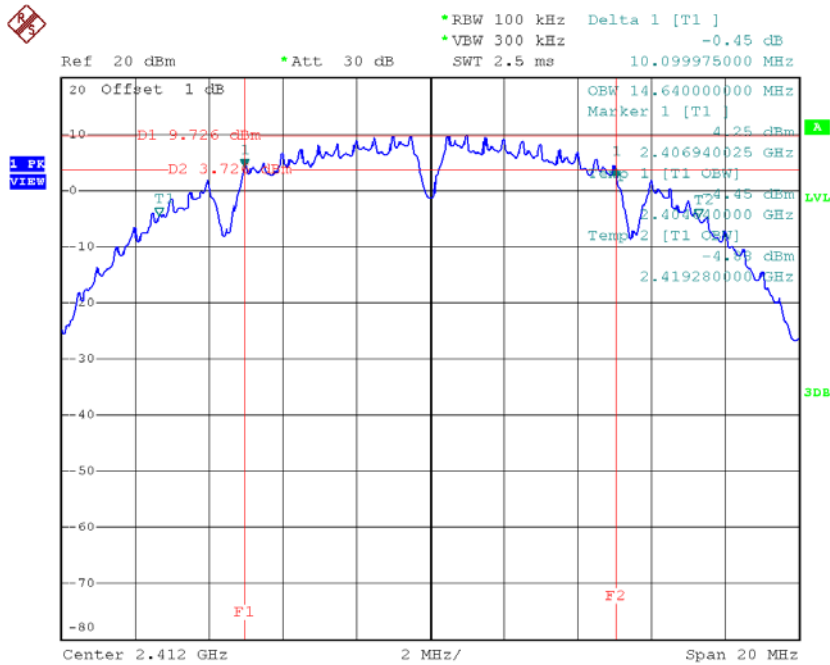

Date: 21.SEP.2016 12:20:21

**TX CH06**

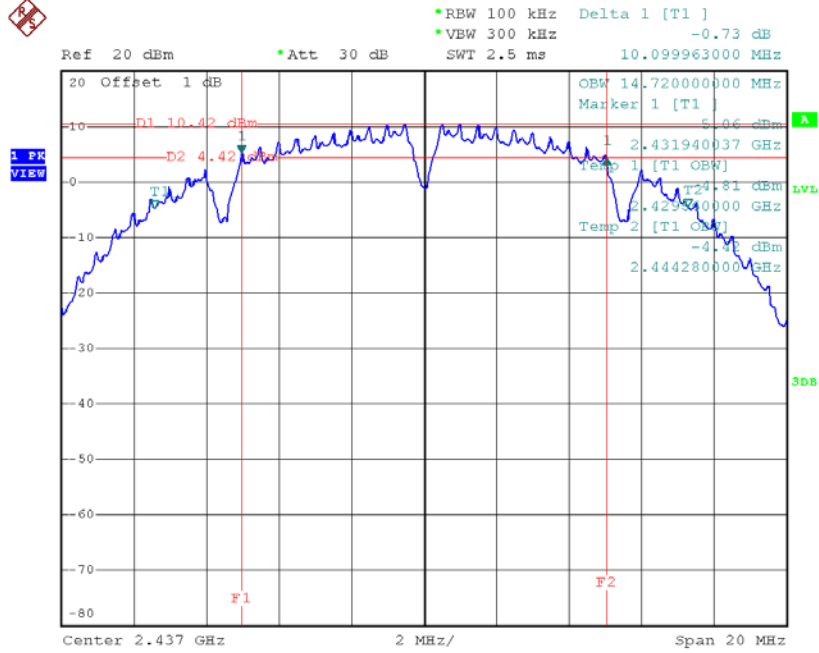

Date: 21.SEP.2016 12:22:19

**TX CH11**

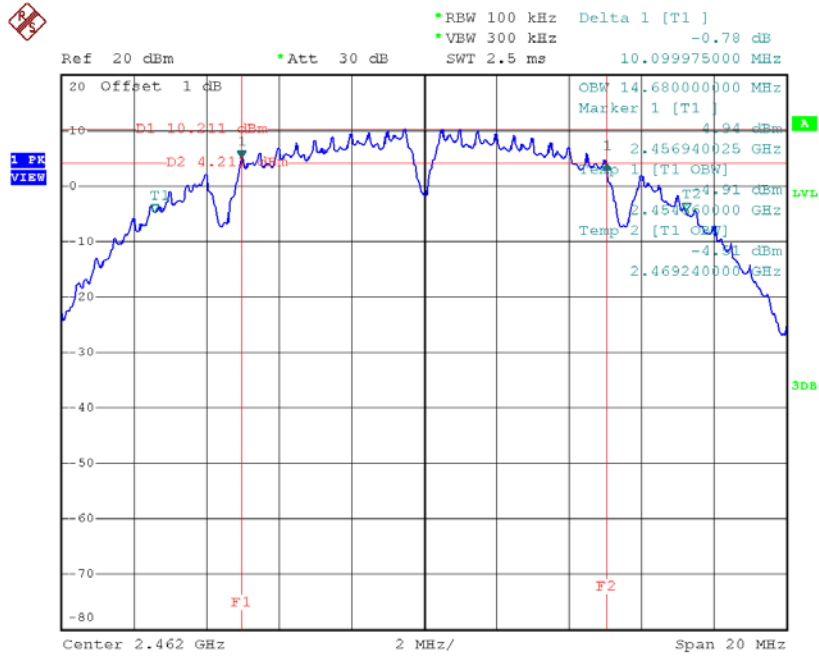

Date: 21.SEP.2016 12:23:38

**Test Mode: TX G Mode\_CH01/06/11**

Frequency (MHz)	6dB Bandwidth (MHz)	99% Occupied BW (MHz)	Min. Limit (kHz)	Test Result
2412	16.53	16.36	500	Complies
2437	16.53	16.44	500	Complies
2462	16.48	16.36	500	Complies

**TX CH01**

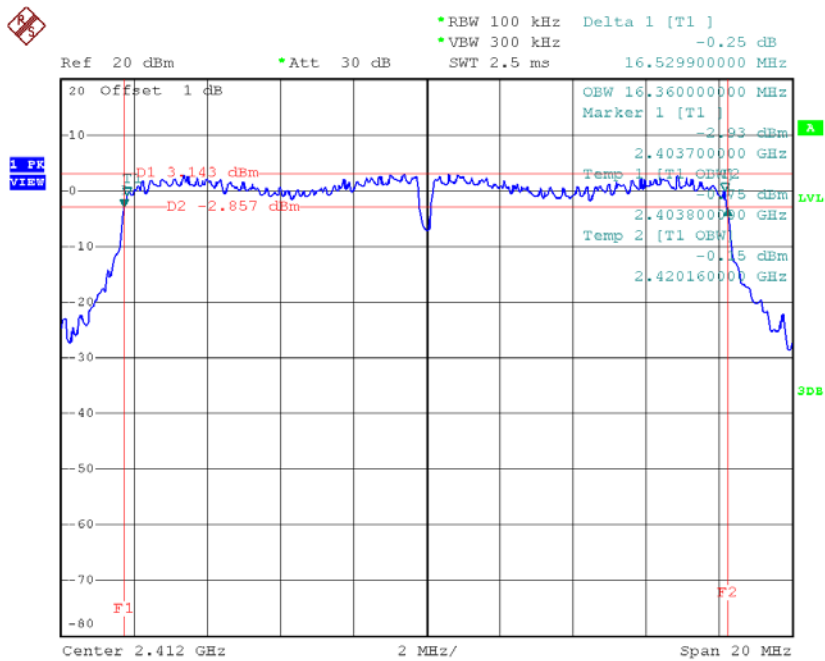

Date: 21.SEP.2016 12:25:06

TX CH06

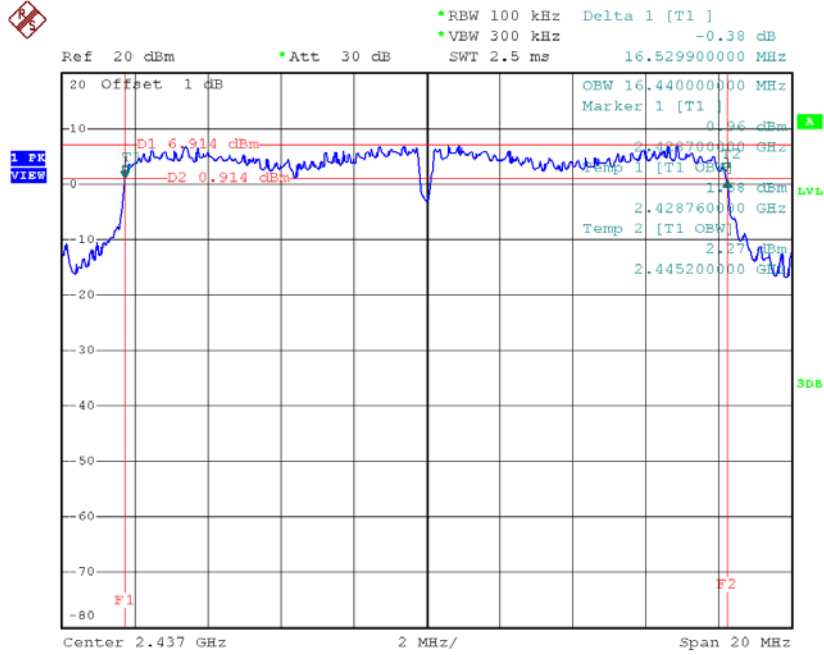

Date: 21.SEP.2016 12:28:21

TX CH11

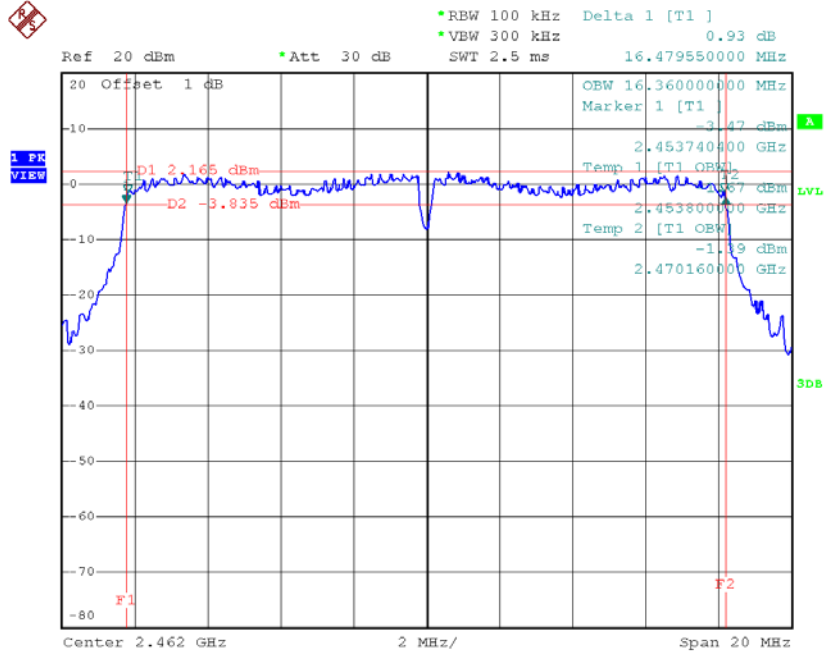

Date: 21.SEP.2016 12:29:35

Test Mode : TX N-20MHz Mode\_CH01/06/11

Frequency (MHz)	6dB Bandwidth (MHz)	99% Occupied BW (MHz)	Min. Limit (kHz)	Test Result
2412	17.62	17.44	500	Complies
2437	17.60	17.44	500	Complies
2462	17.55	17.44	500	Complies

TX CH01

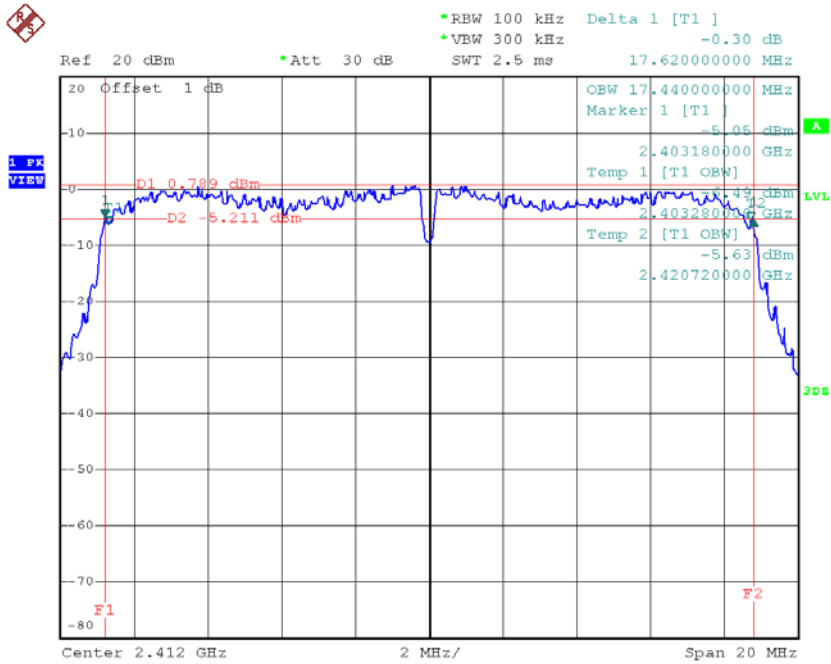

Date: 30.AUG.2016 21:35:35

**TX CH06**

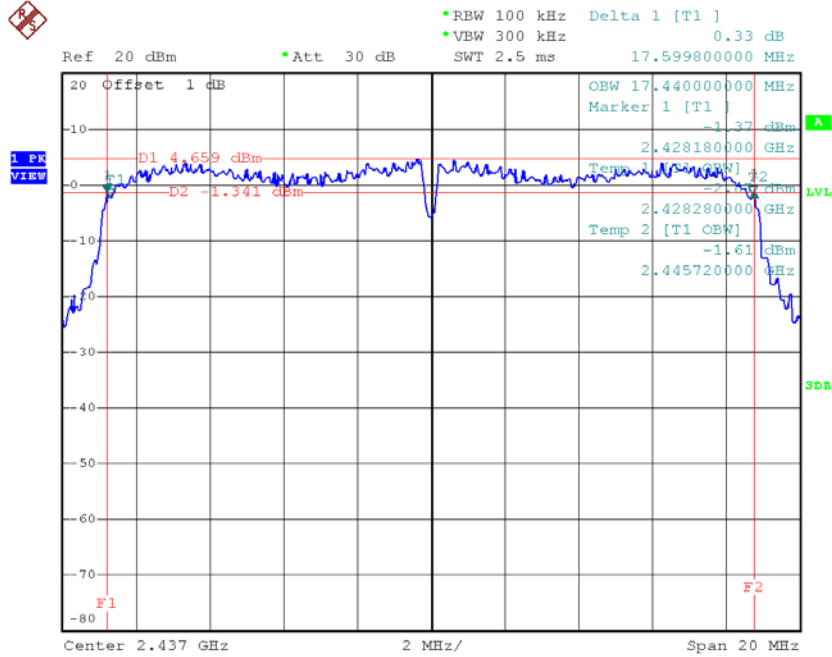

Date: 30.AUG.2016 21:36:50

**TX CH11**

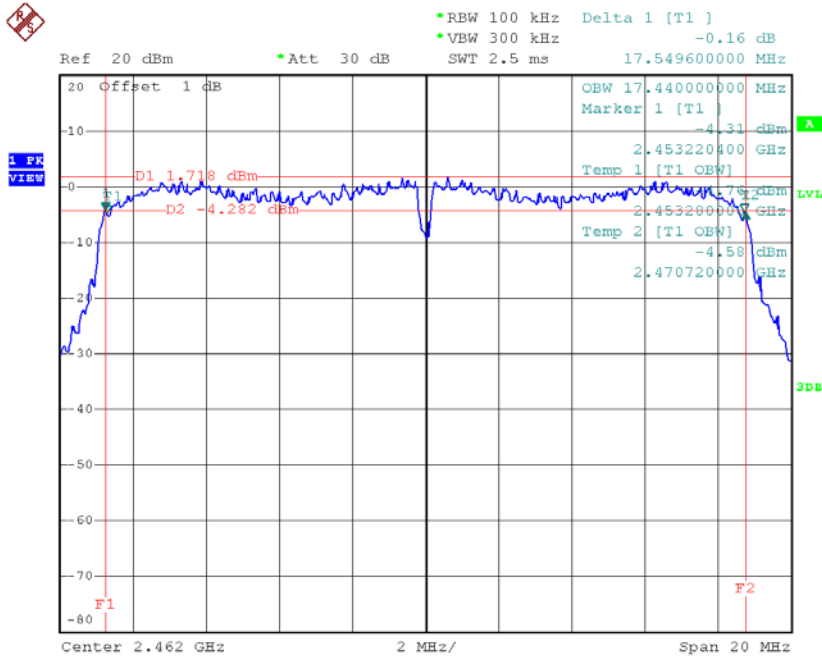

Date: 30.AUG.2016 21:38:03

**Test Mode : TX N-40MHz Mode\_CH03/06/09**

Frequency (MHz)	6dB Bandwidth (MHz)	99% Occupied BW (MHz)	Min. Limit (kHz)	Test Result
2422	36.48	36.00	500	Complies
2437	36.49	36.00	500	Complies
2452	36.56	36.00	500	Complies

**TX CH03**

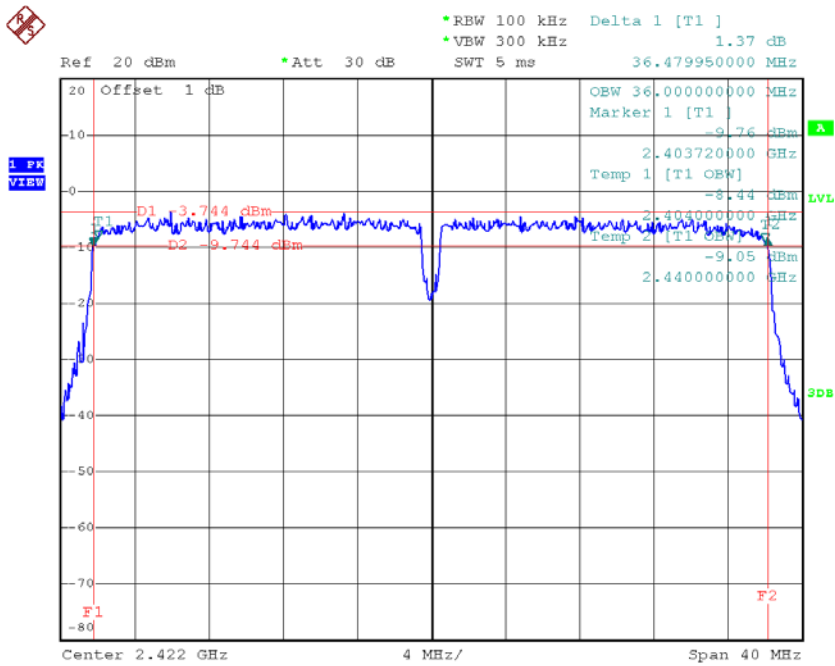

Date: 30.AUG.2016 21:44:14

### TX CH06

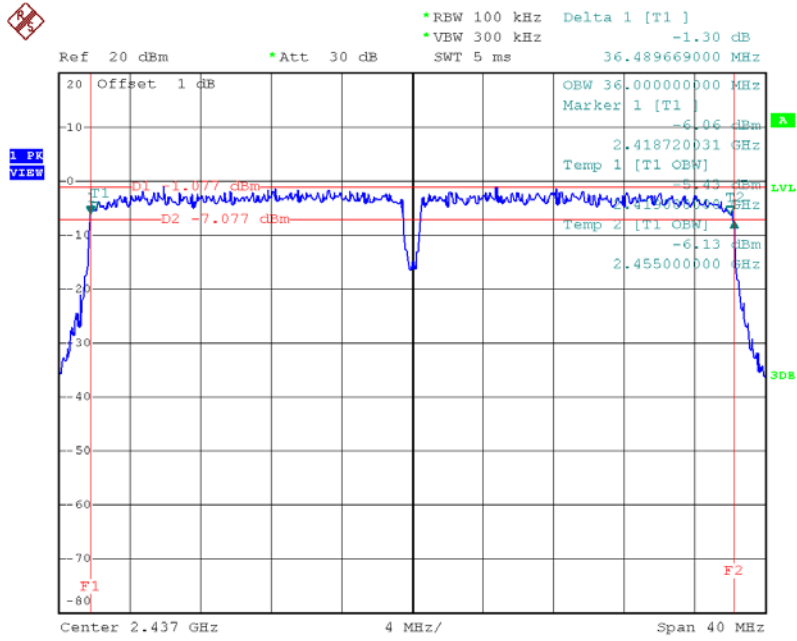

Date: 30.AUG.2016 21:45:41

### TX CH09

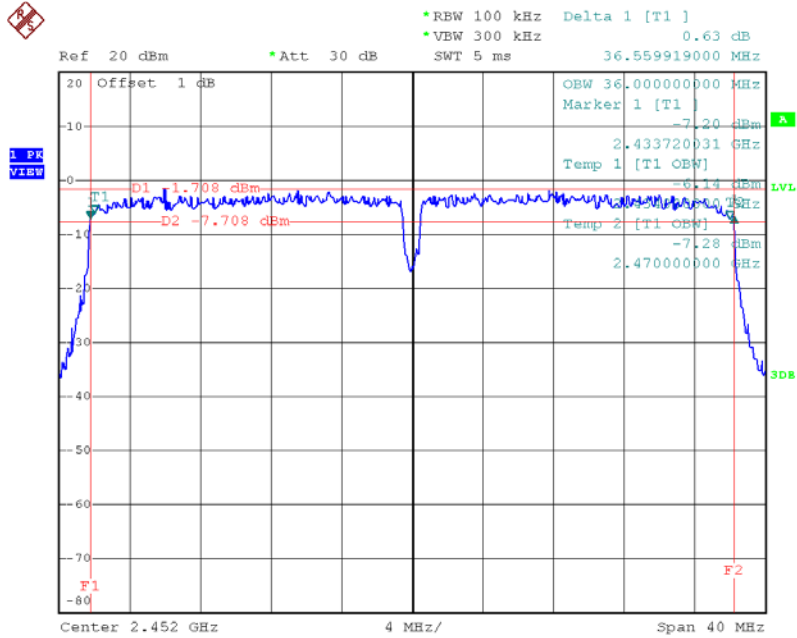

Date: 30.AUG.2016 21:46:52

**ATTACHMENT F– MAXIMUM AVG CONDUCTED OUTPUT  
POWER**

Test Mode :TX B Mode_CH01/06/11					
Frequency (MHz)	Conducted Power (dBm)	Conducted Power (W)	Max. Limit (dBm)	Max. Limit (W)	Result
2412	19.26	0.08433	30.00	1	Complies
2437	20.26	0.10617	30.00	1	Complies
2462	19.97	0.09931	30.00	1	Complies

Test Mode :TX G Mode_CH01/06/11					
Frequency (MHz)	Conducted Power (dBm)	Conducted Power (W)	Max. Limit (dBm)	Max. Limit (W)	Result
2412	16.71	0.04688	30.00	1	Complies
2437	20.42	0.11015	30.00	1	Complies
2462	15.62	0.03648	30.00	1	Complies

Test Mode :TX N20 Mode_CH01/06/11_ANT 1					
Frequency (MHz)	Conducted Power (dBm)	Conducted Power (W)	Max. Limit (dBm)	Max. Limit (W)	Result
2412	14.16	0.0261	30.00	1	Complies
2437	17.75	0.0596	30.00	1	Complies
2462	14.98	0.0315	30.00	1	Complies

Test Mode :TX N20 Mode_CH01/06/11_ANT 2					
Frequency (MHz)	Conducted Power (dBm)	Conducted Power (W)	Max. Limit (dBm)	Max. Limit (W)	Result
2412	14.72	0.0296	30.00	1	Complies
2437	18.41	0.0693	30.00	1	Complies
2462	15.43	0.0349	30.00	1	Complies

Test Mode :TX N20 Mode_CH01/06/11_Total					
Frequency (MHz)	Conducted Power (dBm)	Conducted Power (W)	Max. Limit (dBm)	Max. Limit (W)	Result
2412	17.46	0.0557	30.00	1	Complies
2437	21.10	0.1289	30.00	1	Complies
2462	18.22	0.0664	30.00	1	Complies

Test Mode :TX N40 Mode_CH03/06/09_ANT 1					
Frequency (MHz)	Conducted Power (dBm)	Conducted Power (W)	Max. Limit (dBm)	Max. Limit (W)	Result
2422	12.54	0.0179	30.00	1	Complies
2437	15.37	0.0344	30.00	1	Complies
2452	14.39	0.0275	30.00	1	Complies

Test Mode :TX N40 Mode_CH03/06/09_ANT 2					
Frequency (MHz)	Conducted Power (dBm)	Conducted Power (W)	Max. Limit (dBm)	Max. Limit (W)	Result
2422	12.85	0.0193	30.00	1	Complies
2437	15.74	0.0375	30.00	1	Complies
2452	15.14	0.0327	30.00	1	Complies

Test Mode :TX N40 Mode_CH03/06/09_Total					
Frequency (MHz)	Conducted Power (dBm)	Conducted Power (W)	Max. Limit (dBm)	Max. Limit (W)	Result
2422	15.71	0.0372	30.00	1	Complies
2437	18.57	0.0719	30.00	1	Complies
2452	17.79	0.0601	30.00	1	Complies

# ATTACHMENT G - ANTENNA CONDUCTED SPURIOUS EMISSION

Test Mode : TX B Mode

**TX B mode CH01**

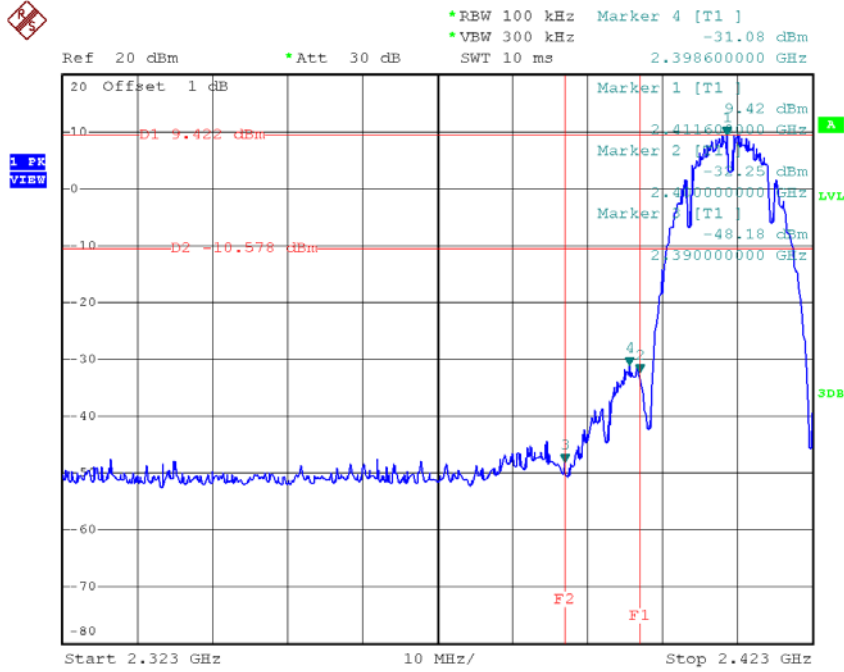

Date: 21.SEP.2016 12:21:00

**TX B mode CH11**

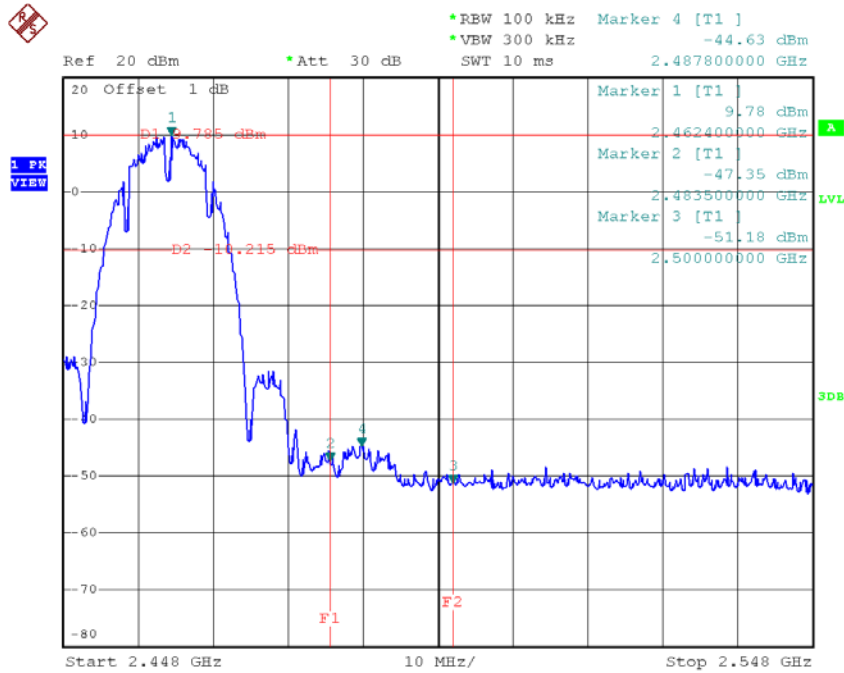

Date: 21.SEP.2016 12:24:17

**TX B mode CH01 (10 Harmonic of the frequency)**

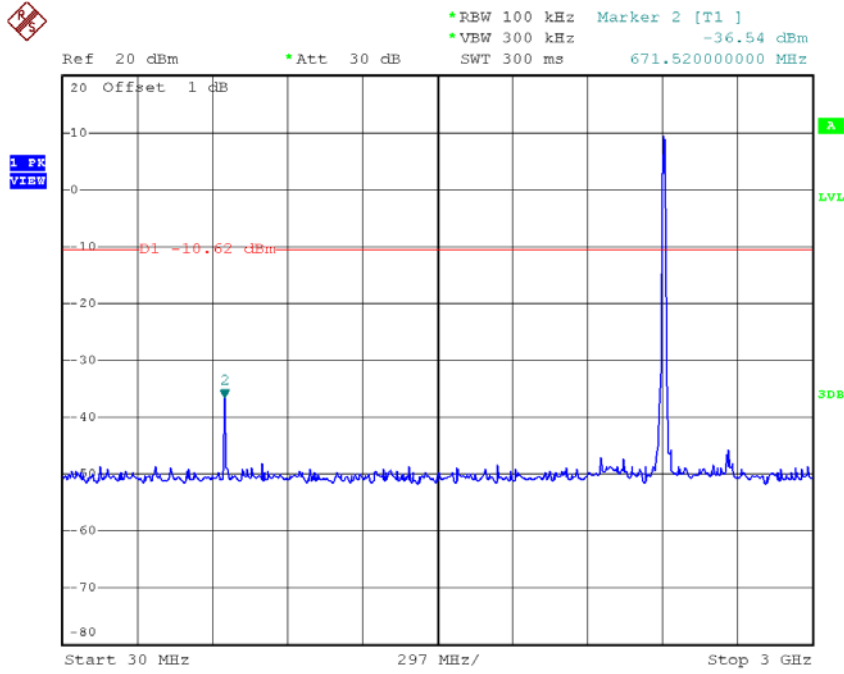

Date: 21.SEP.2016 12:20:36

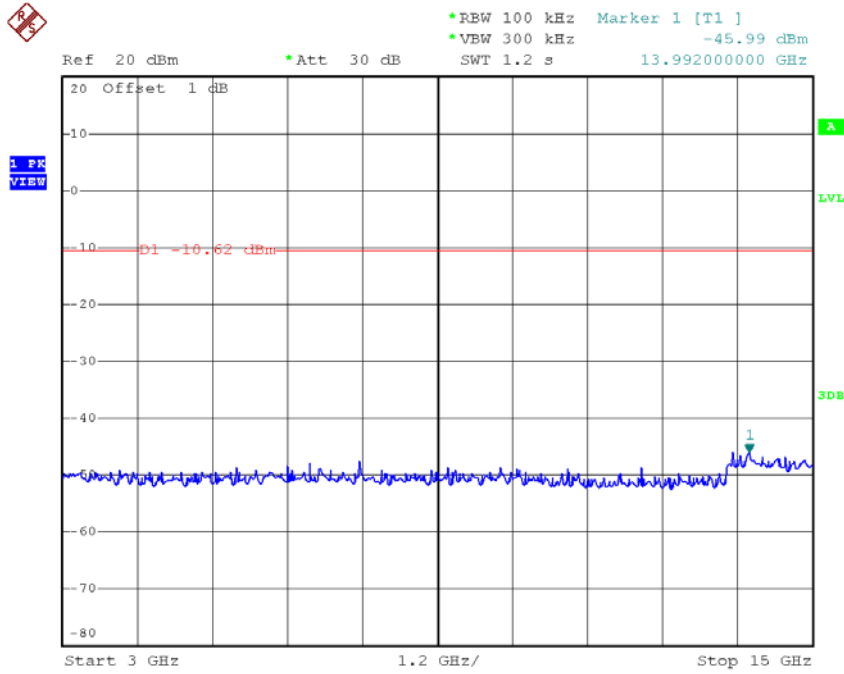

Date: 21.SEP.2016 12:20:44

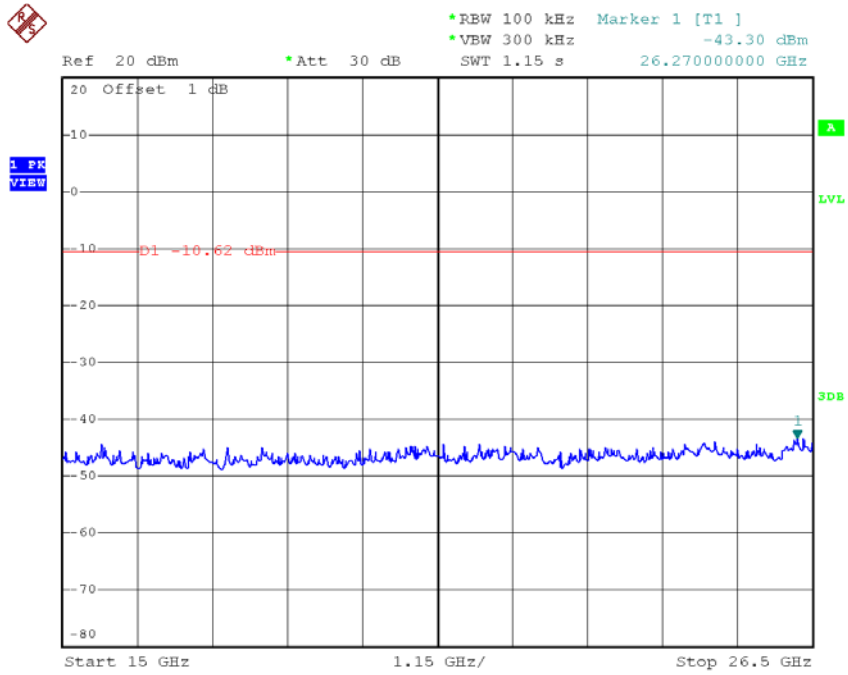

Date: 21.SEP.2016 12:20:52

### TX B mode CH06 (10 Harmonic of the frequency)

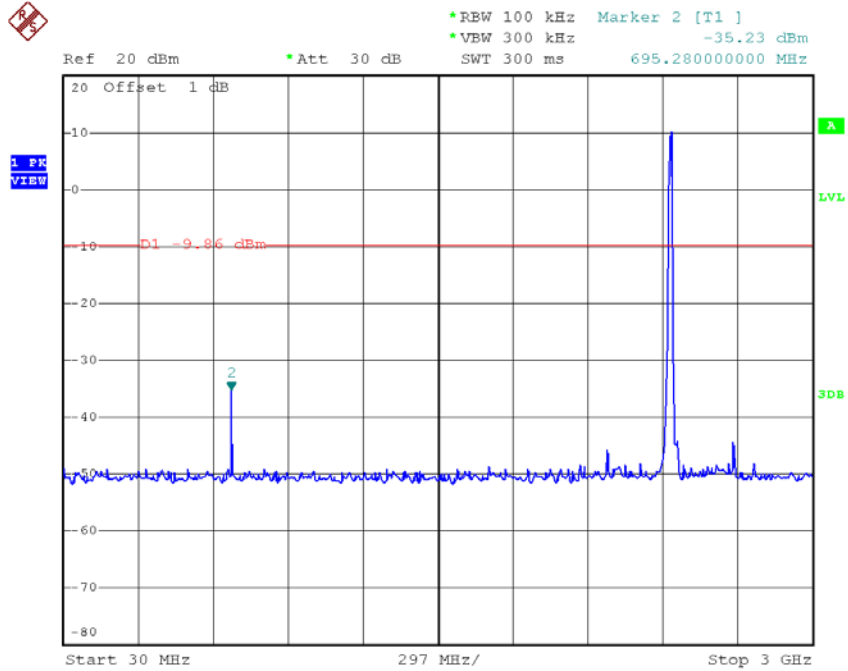

Date: 21.SEP.2016 12:22:33

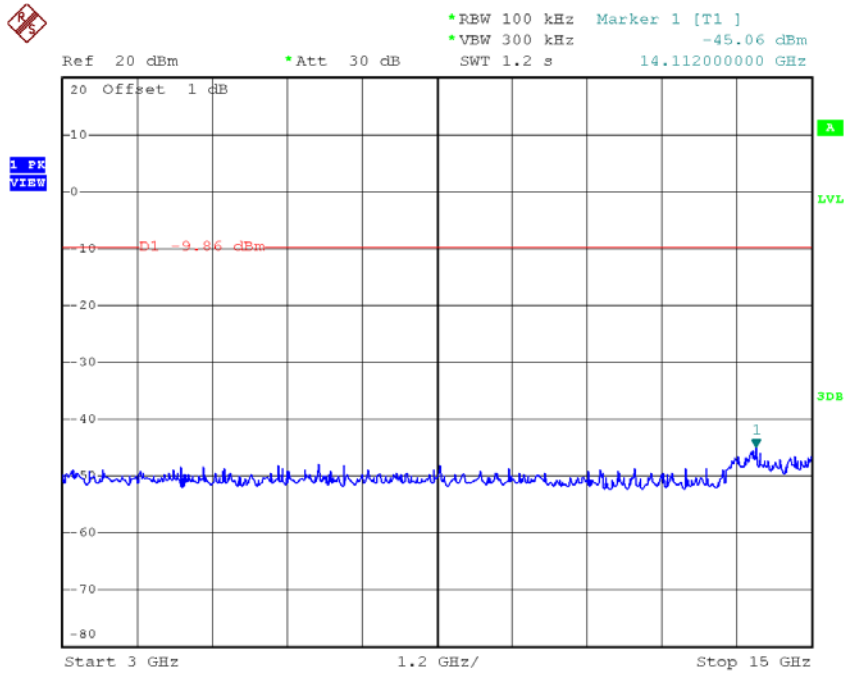

Date: 21.SEP.2016 12:22:42

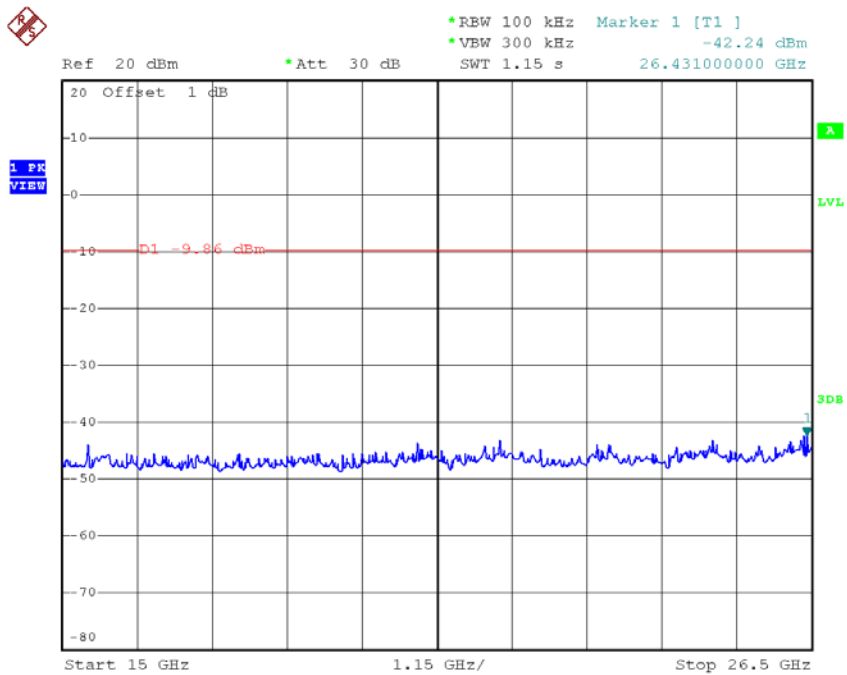

Date: 21.SEP.2016 12:22:50

**TX B mode CH11 (10 Harmonic of the frequency)**

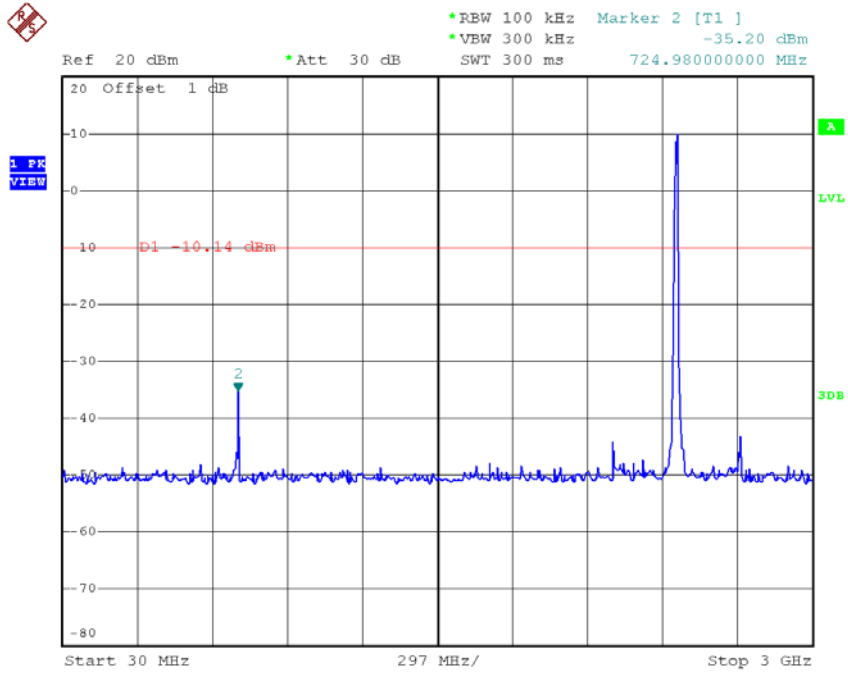

Date: 21.SEP.2016 12:23:52

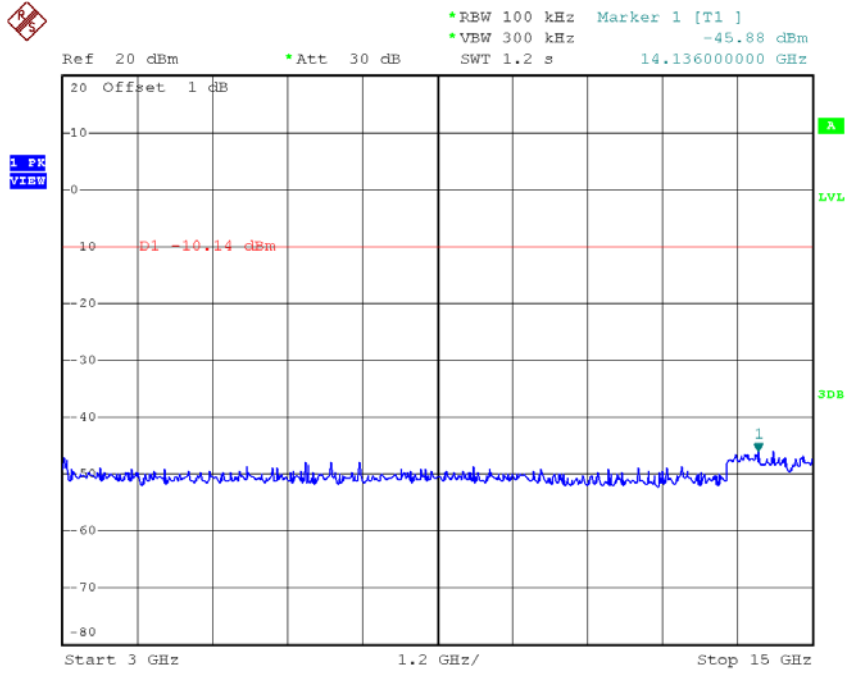

Date: 21.SEP.2016 12:24:01

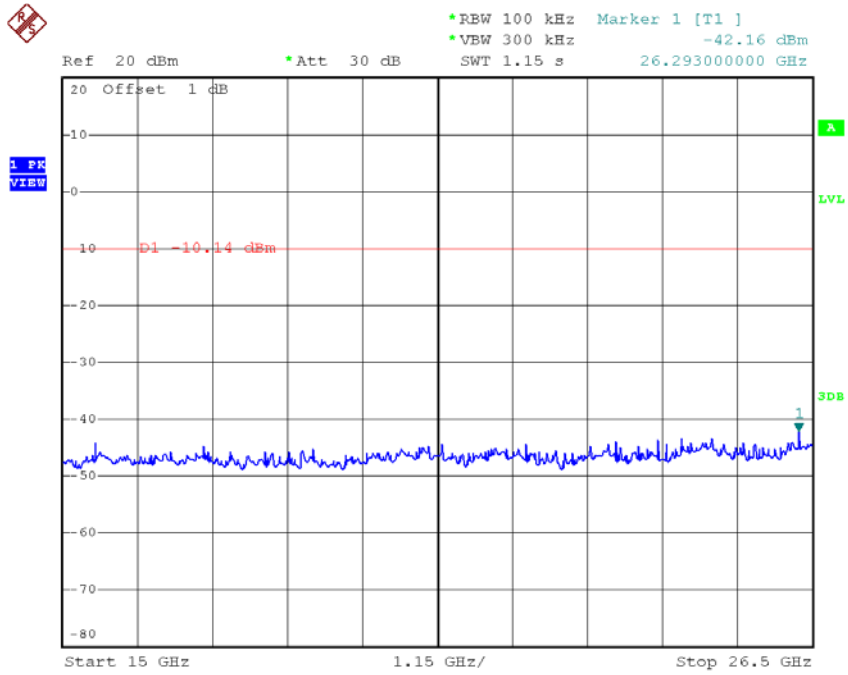

Date: 21.SEP.2016 12:24:09

Test Mode : TX G Mode

**TX G mode CH01**

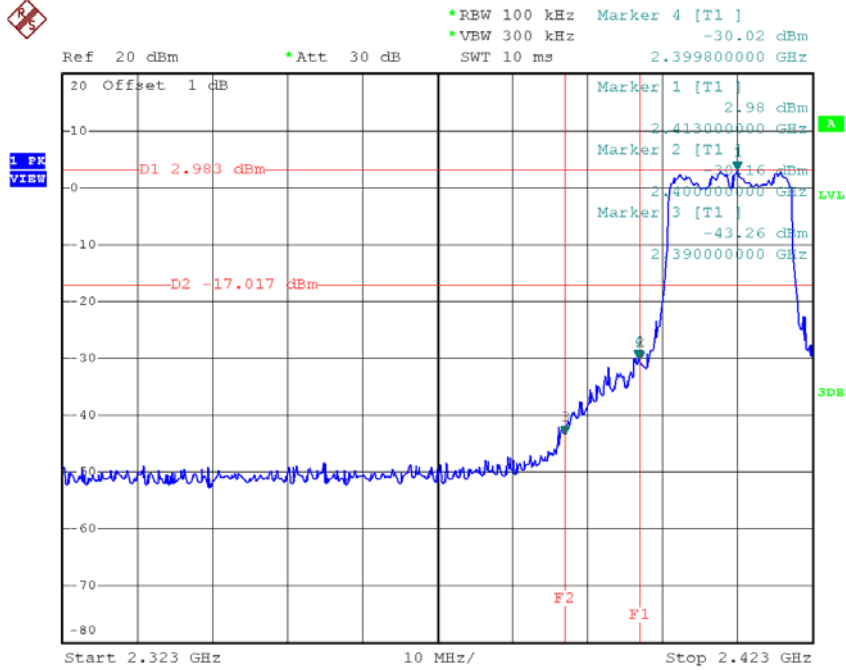

Date: 21.SEP.2016 12:25:45

**TX G mode CH11**

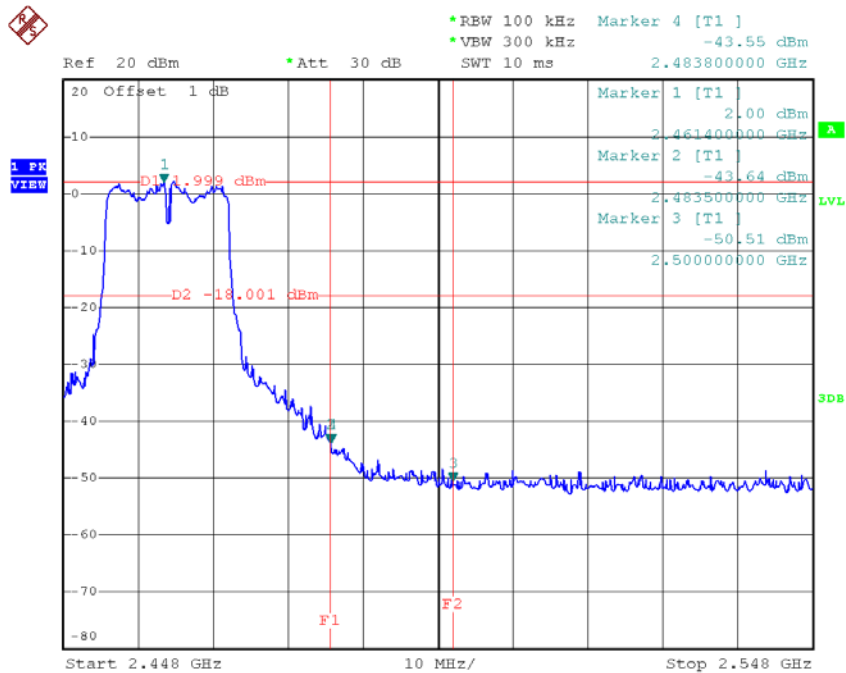

Date: 21.SEP.2016 12:30:13

### TX G mode CH01 (10 Harmonic of the frequency)

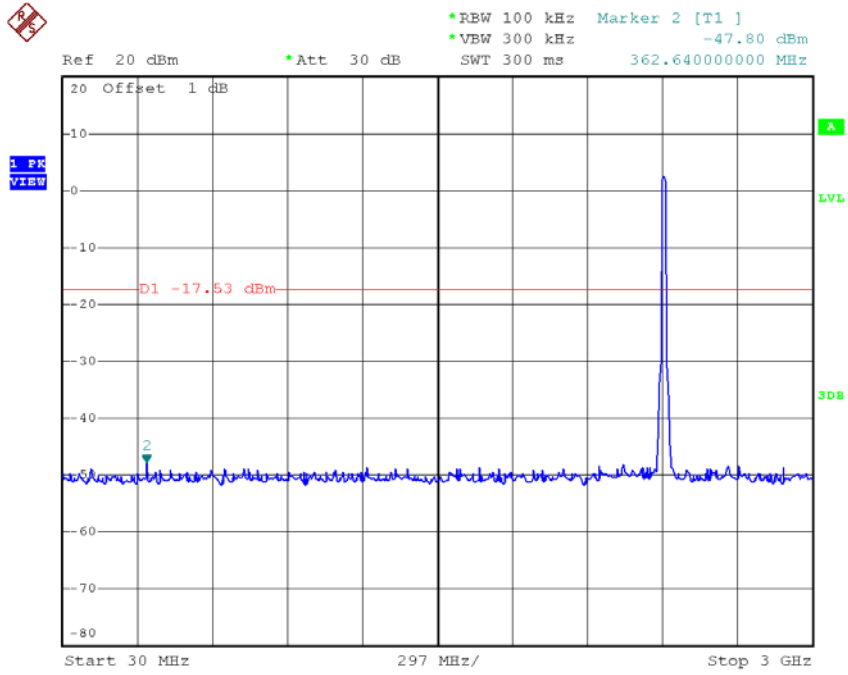

Date: 21.SEP.2016 12:25:20

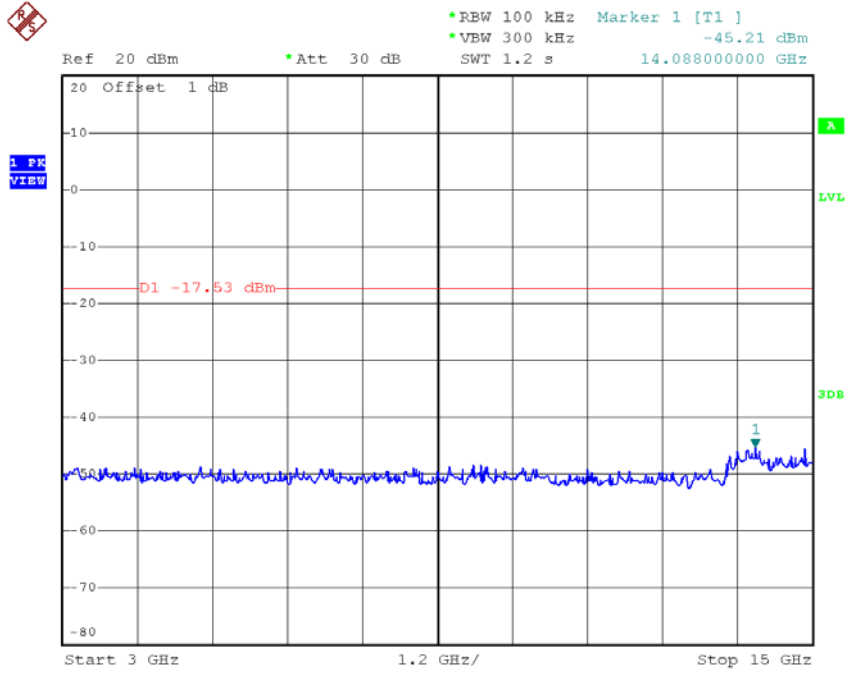

Date: 21.SEP.2016 12:25:29

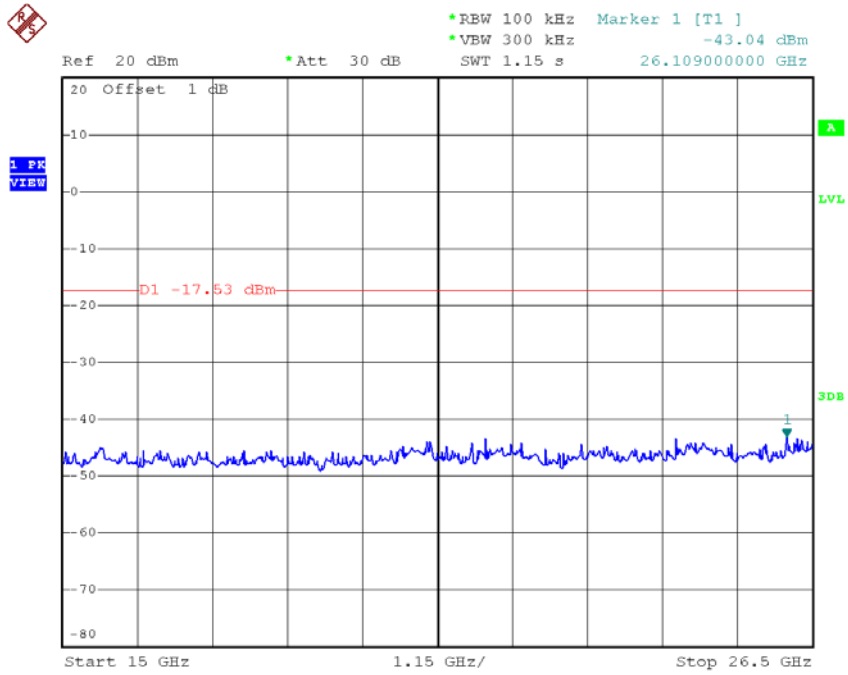

Date: 21.SEP.2016 12:25:37

### TX G mode CH06 (10 Harmonic of the frequency)

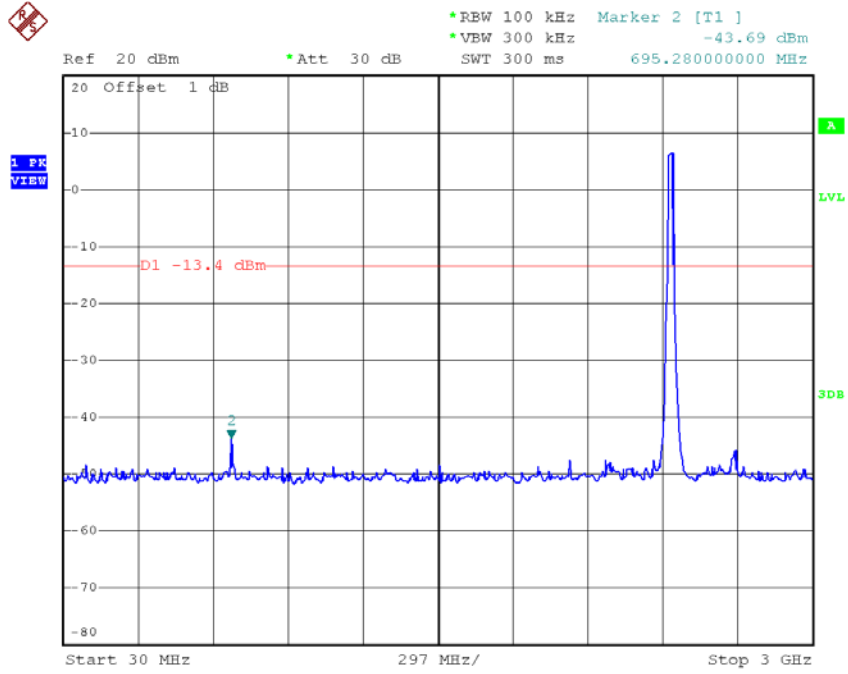

Date: 21.SEP.2016 12:28:35