

FCC TEST REPORT (15.247)

REPORT NO.: RF930705L07C

MODEL NO.: DWL-7230AP, DWL-7200AP

RECEIVED: May 12, 2006

TESTED: May 15 to 25, 2006

ISSUED: May 26, 2006

APPLICANT: D-LINK CORPORATION

ADDRESS: No.289, Shinhu 3rd Rd., Neihu District,
Taipie City 114, Taiwan, R.O.C.

ISSUED BY: Advance Data Technology Corporation

TEST LOCATION: No. 81-1, Lu Liao Keng, 9 Ling, Wu Lung
Tsuen, Chiung Lin Hsiang, Hsin Chu Hsien,
Taiwan, R.O.C.

This test report consists of 76 pages in total. It may be duplicated completely for legal use with the approval of the applicant. It should not be reproduced except in full, without the written approval of our laboratory. The client should not use it to claim product endorsement by CNLA, A2LA or any government agencies. The test results in the report only apply to the tested sample.



No. 2177-01

Table of Contents

1.	CERTIFICATION	4
2.	SUMMARY OF TEST RESULTS	5
3.	GENERAL INFORMATION	6
3.1	GENERAL DESCRIPTION OF EUT	6
3.2	DESCRIPTION OF TEST MODES	9
3.3	TEST MODE APPLICABILITY AND TESTED CHANNEL DETAIL:	10
3.4	GENERAL DESCRIPTION OF APPLIED STANDARDS	12
3.5	DESCRIPTION OF SUPPORT UNITS.....	13
3.6	CONFIGURATION OF SYSTEM UNDER TEST	14
4.	TEST TYPES AND RESULTS (802.11b & g, 2412~2462MHz Band)	16
4.1	RADIATED EMISSION MEASUREMENT	16
4.1.1	LIMITS OF RADIATED EMISSION MEASUREMENT.....	16
4.1.2	TEST INSTRUMENTS.....	17
4.1.3	TEST PROCEDURES	18
4.1.4	DEVIATION FROM TEST STANDARD	18
4.1.5	TEST SETUP	19
4.1.6	EUT OPERATING CONDITIONS	19
4.1.7	TEST RESULTS	20
4.2	MAXIMUM PEAK OUTPUT POWER.....	29
4.2.1	LIMITS OF MAXIMUM PEAK OUTPUT POWER MEASUREMENT	29
4.2.2	INSTRUMENTS.....	29
4.2.3	TEST PROCEDURES	30
4.2.4	DEVIATION FROM TEST STANDARD	30
4.2.5	TEST SETUP	30
4.2.6	EUT OPERATING CONDITIONS	30
4.2.7	TEST RESULTS	31
4.3	BAND EDGES MEASUREMENT.....	33
4.3.1	LIMITS OF BAND EDGES MEASUREMENT	33
4.3.2	TEST INSTRUMENTS.....	33
4.3.3	TEST PROCEDURE.....	33
4.3.4	DEVIATION FROM TEST STANDARD	33
4.3.5	EUT OPERATING CONDITION	33
4.3.6	TEST RESULTS	34
4.4	ANTENNA REQUIREMENT	50
4.4.1	STANDARD APPLICABLE.....	50
4.4.2	ANTENNA CONNECTED CONSTRUCTION.....	50
5.	TEST TYPES AND RESULTS (802.11a, 5725~5850MHz Band)	51
5.1	RADIATED EMISSION MEASUREMENT	51
5.1.1	LIMITS OF RADIATED EMISSION MEASUREMENT.....	51



5.1.2	TEST INSTRUMENTS.....	52
5.1.3	TEST PROCEDURES	53
5.1.4	DEVIATION FROM TEST STANDARD	53
5.1.5	TEST SETUP	54
5.1.6	EUT OPERATING CONDITIONS	54
5.1.7	TEST RESULTS	55
5.2	MAXIMUM PEAK OUTPUT POWER.....	61
5.2.1	LIMITS OF MAXIMUM PEAK OUTPUT POWER MEASUREMENT	61
5.2.2	INSTRUMENTS.....	61
5.2.3	TEST PROCEDURES	62
5.2.4	DEVIATION FROM TEST STANDARD	62
5.2.5	TEST SETUP	62
5.2.6	EUT OPERATING CONDITIONS	62
5.2.7	TEST RESULTS	63
5.3	BAND EDGES MEASUREMENT.....	64
5.3.1	LIMITS OF BAND EDGES MEASUREMENT	64
5.3.2	TEST INSTRUMENTS.....	64
5.3.3	TEST PROCEDURE.....	64
5.3.4	DEVIATION FROM TEST STANDARD	64
5.3.5	EUT OPERATING CONDITION.....	65
5.3.6	TEST RESULTS	65
5.4	ANTENNA REQUIREMENT	70
5.4.1	STANDARD APPLICABLE.....	70
5.4.2	ANTENNA CONNECTED CONSTRUCTION.....	70
6.	PHOTOGRAPHS OF THE TEST CONFIGURATION.....	71
7.	INFORMATION ON THE TESTING LABORATORIES	75
	APPENDIX-A	A-1



1. CERTIFICATION

PRODUCT: Wireless Access Point
BRAND NAME: D-Link
MODEL NO.: DWL-7230AP, DWL-7200AP
TEST SAMPLE: ENGINEERING SAMPLE
TESTED: May 15 to 25, 2006
APPLICANT: D-LINK CORPORATION
STANDARDS: FCC Part 15, Subpart C (Section 15.247),
ANSI C63.4-2003

The above equipment (Model: DWL-7230AP) has been tested by **Advance Data Technology Corporation**, and found compliance with the requirement of the above standards. The test record, data evaluation & Equipment Under Test (EUT) configurations represented herein are true and accurate accounts of the measurements of the sample's EMC characteristics under the conditions specified in this report.

PREPARED BY : Carol Liao , **DATE:** May 26, 2006
(Carol Liao)

TECHNICAL ACCEPTANCE : Hank Chung , **DATE:** May 26, 2006
Responsible for RF (Hank Chung)

APPROVED BY : May Chen , **DATE:** May 26, 2006
(May Chen, Deputy Manager)

2. SUMMARY OF TEST RESULTS

The EUT has been tested according to the following specifications:

For 802.11b & g, 2412~2462MHz Band

APPLIED STANDARD: FCC Part 15, Subpart C (Section 15.247)			
Standard Section	Test Type and Limit	Result	Remark
15.247(b)	Maximum Peak Output Power Limit: max. 30dBm	PASS	Meet the requirement of limit.
15.247(d)	Radiated Emissions Limit: Table 15.209	PASS	Meet the requirement of limit. Minimum passing margin is -0.8dB at 124.99MHz
15.247(d)	Band Edge Measurement Limit: 20dB less than the peak value of fundamental frequency	PASS	Meet the requirement of limit.

For 802.11a, 5725~5850MHz Band

APPLIED STANDARD: FCC Part 15, Subpart C (Section 15.247)			
Standard Section	Test Type and Limit	Result	Remark
15.247(b)	Maximum Peak Output Power Limit: max. 30dBm	PASS	Meet the requirement of limit.
15.247(d)	Radiated Emissions Limit: Table 15.209	PASS	Meet the requirement of limit. Minimum passing margin is -0.8dB at 124.99MHz
15.247(d)	Band Edge Measurement Limit: 20dB less than the peak value of fundamental frequency	PASS	Meet the requirement of limit.

NOTE:

1. The EUT was operating in 2.412 ~ 2.462GHz, 5.150 ~ 5.350GHz and 5.725 ~ 5.850GHz frequencies band. This report was recorded the RF parameters including 2.412 ~ 2.462GHz and 5.725 ~ 5.850GHz. For the 5.150 ~ 5.350GHz RF parameters was recorded in another test report.
2. This report is prepared for FCC class II permissive change. Only radiated emission, Maximum Peak Output Power and Band Edge Measurement were presented in this test report.

3. GENERAL INFORMATION

3.1 GENERAL DESCRIPTION OF EUT

EUT	Wireless Access Point
MODEL NO.	DWL-7230AP, DWL-7200AP
FCC ID	KA2-DWL7200APA1
POWER SUPPLY	48VDC from Power adapter or POE
MODULATION TYPE	CCK, DQPSK, DBPSK for DSSS 64QAM, 16QAM, QPSK, BPSK for OFDM
MODULATION TECHNOLOGY	DSSS, OFDM
TRANSFER RATE	802.11b: 11/5.5/2/1Mbps 802.11g: 54/48/36/24/18/12/9/6Mbps 802.11a: 54/48/36/24/18/12/9/6Mbps (Turbo mode: up to 108Mbps *see Note 1)
FREQUENCY RANGE	802.11b & 802.11g: 2412 ~ 2462MHz 802.11a: 5.15 ~ 5.35GHz and 5.725 ~ 5.850GHz
NUMBER OF CHANNEL	802.11b & 802.11g: 11 (1 for 802.11g Turbo mode) 802.11a: 13 (5 for 802.11a Turbo mode)
CHANNEL SPACING	802.11b & 802.11g: 5MHz 802.11a: 20MHz for Normal mode / 40MHz for Turbo mode
OUTPUT POWER	802.11b: 40.738mW 802.11g: 48.978mW 802.11a: 39.537mW
DATA CABLE	NA
ANTENNA TYPE	Please see note 3
I/O PORTS	See Note 5
ASSOCIATED DEVICES	NA

NOTE:

1. This EUT is capable of providing data rates of up to 108Mbps in Turbo Mode depending upon reception quality.
2. The EUT is a Wireless Access Point, which contains two radios capable of simultaneous 802.11b/g (2.4GHz) and 802.11a (5GHz) operations.
3. There are two antennas provided to this EUT, please refer to the following table:

No.	Gain (dBi)	Antenna Type	Antenna Connector
1	5.0 (for 2.4GHz & 5.0GHz)	Dipole	RP-SMA
2	-2.0(for 2.4GHz)	Printed	NA
	-1.07(for 5.15-5.35GHz) 3.02(for 5.725-5.85GHz)		

4. This report is prepared for FCC class II permissive change. The difference compared with the Report No.:RF930705L07 design is as the following:

◆ The function of printed antenna has been changed as below:

Original			
Gain (dBi)	Antenna Type	Antenna Connector	Remark
-2.0(for 2.4GHz)	Printed	NA	Rx function only
-1.07(for 5.15-5.35GHz)			
3.02(for 5.725-5.85GHz)			
New			
Gain (dBi)	Antenna Type	Antenna Connector	Remark
-2.0(for 2.4GHz)	Printed	NA	Tx and Rx function
-1.07(for 5.15-5.35GHz)			
3.02(for 5.725-5.85GHz)			

◆ Parts of the components (Bead, Capacitance, Diode) have been changed.

5. The EUT has two model names both have following two samples:

Model Name	Samples
DWL-7230AP, DWL-7200AP	Sample 1: With one RJ 45 port
	Sample 2: With two RJ 45ports

Above samples were pre-tested in chamber, **Sample 1**, worst case one, was chosen for final test and its data was recorded in this report.

6. The EUT has following two model names:

Brand	Model Name	Difference
D-Link	DWL-7230AP	for marketing issue
D-Link	DWL-7200AP	for marketing issue

From the above models, model: **DWL-7230AP** was selected as representative model for the test and its data were recorded in this report.

7. The EUT was powered either adapter or POE (Power Over Ethernet):

Adapter :	
Brand:	Bothhand Enterprise Inc.
Model No.:	SA06L48-V
Input power :	100-240V~0.6A 50-60Hz
Output power :	48V / 0.4A

POE:	
Brand:	Bothhand Enterprise Inc.
Model No.:	EBU-101-T1
Input power :	100-240V ~ 0.6A, 50-60Hz
Output power :	48V===0.4A

8. The above EUT information was declared by the manufacturer and for more detailed features description, please refer to the manufacturer's specifications or User's Manual.

3.2 DESCRIPTION OF TEST MODES

Operated in 2400 ~ 2483.5MHz band:

For 802.11b/g: Eleven channels are provided to this EUT.

Channel	Frequency	Channel	Frequency
1	2412 MHz	7	2442 MHz
2	2417 MHz	8	2447 MHz
3	2422 MHz	9	2452 MHz
4	2427 MHz	10	2457 MHz
5	2432 MHz	11	2462 MHz
6	2437 MHz		

For 802.11g turbo mode: One channel is provided to this EUT

Channel	Frequency
1	2437 MHz

Operated in 5725 ~ 5850MHz band:

For 802.11a (5725 ~ 5850MHz band): Five channels are provided to this EUT.

Channel	Frequency
1	5745 MHz
2	5765 MHz
3	5785 MHz
4	5805 MHz
5	5825 MHz

For 802.11a turbo mode (5725 ~ 5850MHz band): Two channels are provided to this EUT.

Channel	Frequency
1	5760 MHz
2	5800 MHz

3.3 TEST MODE APPLICABILITY AND TESTED CHANNEL DETAIL:

EUT configure mode	Applicable to				Description
	PLC	RE<1G	RE≥1G	APCM	
-	X	√	√	√	NA

Where PLC: Power Line Conducted Emission

RE<1G RE: Radiated Emission below 1GHz

RE≥1G: Radiated Emission above 1GHz

APCM: Antenna Port Conducted Measurement

Radiated Emission Test (Below 1 GHz):

- Pre-Scan has been conducted to determine the worst-case mode from all possible combinations between available modulations, data rates and antenna ports (if EUT with antenna diversity architecture).
- Following channel(s) was (were) selected for the final test as listed below.

Mode	Available Channel	Tested Channel	Modulation Technology	Modulation Type	Data Rate (Mbps)
802.11g	1 to 11	11	OFDM	BPSK	6
802.11a	1 to 5	5	OFDM	BPSK	6

- The EUT was tested with the following test modes:

Test Mode	Sample	POWER
Mode A	Sample 1	Wth Adapter
Mode B	Sample 1	Wth Adapter & POE

Radiated Emission Test (Above 1 GHz):

- Pre-Scan has been conducted to determine the worst-case mode from all possible combinations between available modulations, data rates and antenna ports (if EUT with antenna diversity architecture).
- Following channel(s) was (were) selected for the final test as listed below.

Mode	Available Channel	Tested Channel	Modulation Technology	Modulation Type	Data Rate (Mbps)
802.11b	1 to 11	1, 6, 11	DSSS	CCK	11
802.11g	1 to 11	1, 6, 11	OFDM	BPSK	6
802.11g turbo	6	6	OFDM	BPSK	12
802.11a	1 to 5	1, 5	OFDM	BPSK	6
802.11a turbo	1, 2	1, 2	OFDM	BPSK	12

- The EUT was pre-tested in chamber as the following test modes:

Test Mode	Sample	POWER
Mode A	Sample 1	Wth Adapter
Mode B	Sample 1	Wth Adapter & POE

The worse radiated emission (Above 1 GHz) was found in **Mode A**: The EUT with adapter, worse case one, was chosen for final test.

Bandedge Measurement:

- Pre-Scan has been conducted to determine the worst-case mode from all possible combinations between available modulations, data rates and antenna ports (if EUT with antenna diversity architecture).
- Following channel(s) was (were) selected for the final test as listed below.

Mode	Available Channel	Tested Channel	Modulation Technology	Modulation Type	Data Rate (Mbps)
802.11b	1 to 11	1, 6, 11	DSSS	CCK	11
802.11g	1 to 11	1, 6, 11	OFDM	BPSK	6
802.11g turbo	6	6	OFDM	BPSK	12
802.11a	1 to 5	1, 5	OFDM	BPSK	6
802.11a turbo	1, 2	1, 2	OFDM	BPSK	12

Antenna Port Conducted Measurement:

- Pre-Scan has been conducted to determine the worst-case mode from all possible combinations between available modulations, data rates and antenna ports (if EUT with antenna diversity architecture).
- Following channel(s) was (were) selected for the final test as listed below.

Mode	Available Channel	Tested Channel	Modulation Technology	Modulation Type	Data Rate (Mbps)
802.11b	1 to 11	1, 6, 11	DSSS	CCK	11
802.11g	1 to 11	1, 6, 11	OFDM	BPSK	6
802.11g turbo	6	6	OFDM	BPSK	12
802.11a	1 to 5	1, 5	OFDM	BPSK	6
802.11a turbo	1, 2	1, 2	OFDM	BPSK	12



3.4 GENERAL DESCRIPTION OF APPLIED STANDARDS

The EUT is a Wireless Access Point. According to the specifications of the manufacturer, it must comply with the requirements of the following standards:

FCC Part 15, Subpart C. (15.247)

ANSI C63.4-2003

All test items have been performed and recorded as per the above standards.

NOTE: The EUT is also considered as a kind of computer peripheral, because the connection to computer is necessary for typical use. It has been verified to comply with the requirements of FCC Part 15, Subpart B, Class B (DoC). The test report has been issued separately.



3.5 DESCRIPTION OF SUPPORT UNITS

The EUT has been tested as an independent unit together with other necessary accessories or support units. The following support units or accessories were used to form a representative test configuration during the tests.

NO.	PRODUCT	BRAND	MODEL NO.	SERIAL NO.	FCC ID
1	Notebook Computer	DELL	PP01L	TW-09C748-12800-1A3-1999	FCC DoC

NO.	SIGNAL CABLE DESCRIPTION OF THE ABOVE SUPPORT UNITS
1	NA

NOTE: All power cords of the above support units are non-shielded (1.8m).

3.6 CONFIGURATION OF SYSTEM UNDER TEST

WITH ADAPTER:

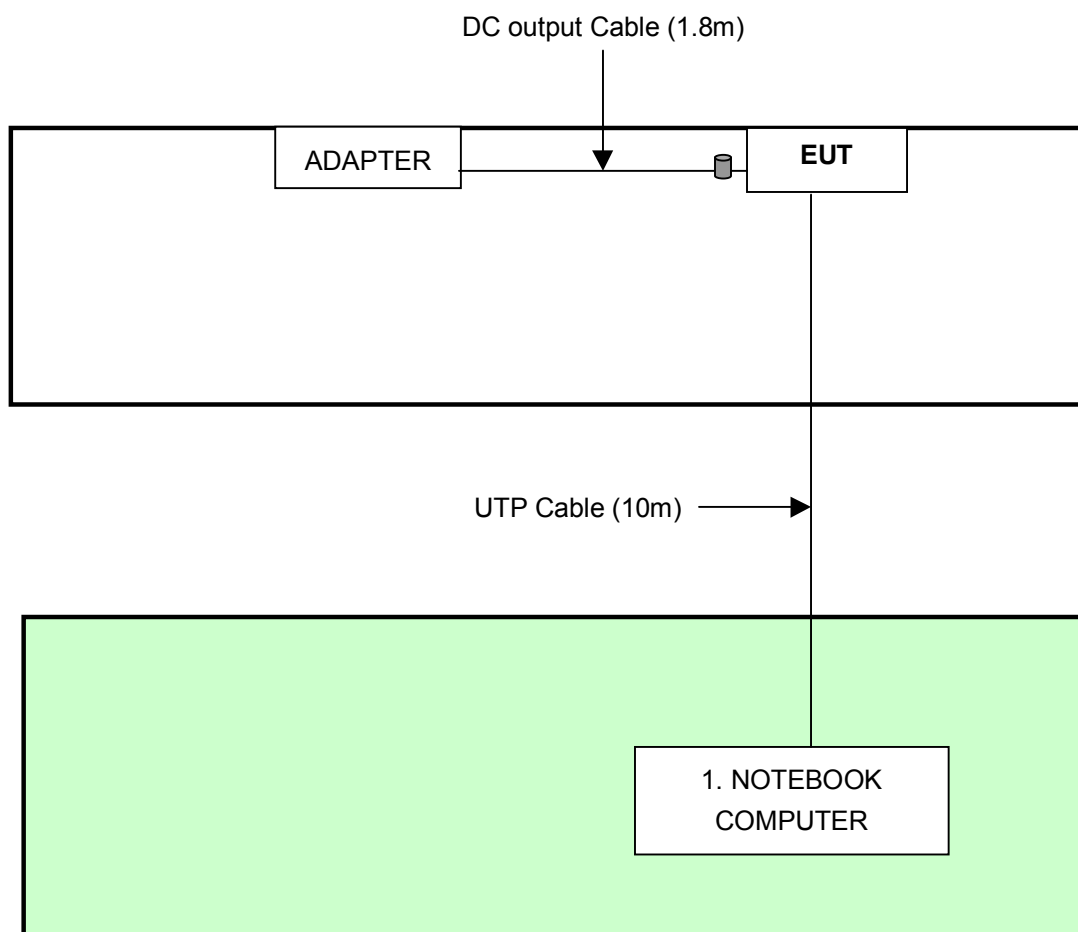

- NOTE:** 1. Support unit 1 was kept in the control room during the test.
2. Please refer to the photos of test configuration in Item 6 also.

WITH POE:

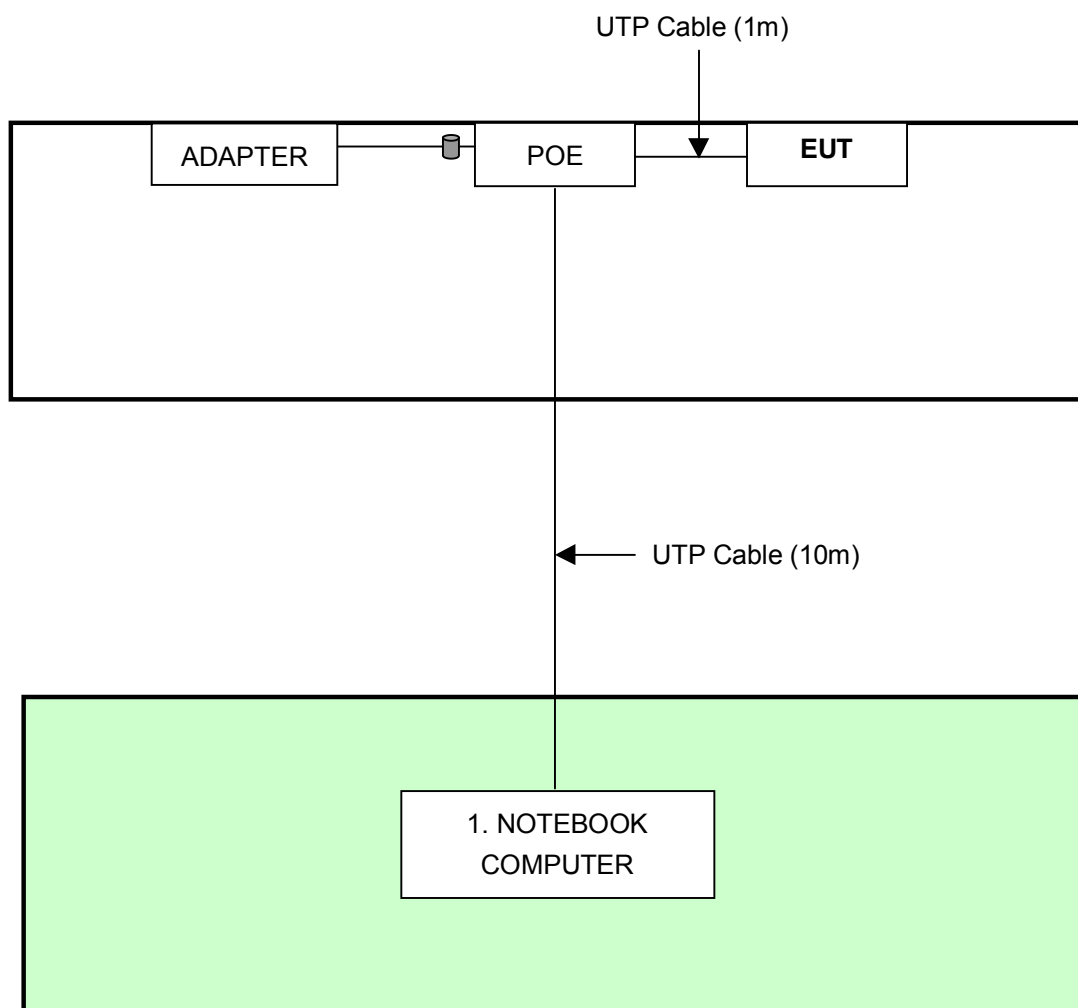

- NOTE:** 1. Support unit 1 was kept in the control room during the test.
2. Please refer to the photos of test configuration in Item 6 also.

4. TEST TYPES AND RESULTS (802.11b & g, 2412~2462MHz Band)

4.1 RADIATED EMISSION MEASUREMENT

4.1.1 LIMITS OF RADIATED EMISSION MEASUREMENT

Emissions radiated outside of the specified bands, shall be according to the general radiated limits in 15.209 as following:

Frequencies (MHz)	Field strength (microvolts/meter)	Measurement distance (meters)
0.009-0.490	2400/F(kHz)	300
0.490-1.705	24000/F(kHz)	30
1.705-30.0	30	30
30-88	100	3
88-216	150	3
216-960	200	3
Above 960	500	3

NOTE:

1. The lower limit shall apply at the transition frequencies.
2. Emission level (dBuV/m) = 20 log Emission level (uV/m).
3. As shown in 15.35(b), for frequencies above 1000MHz, the field strength limits are based on average detector, however, the peak field strength of any emission shall not exceed the maximum permitted average limits, specified above by more than 20dB under any condition of modulation.



4.1.2 TEST INSTRUMENTS

DESCRIPTION & MANUFACTURER	MODEL NO.	SERIAL NO.	CALIBRATED UNTIL
ADVANTEST Spectrum Analyzer	R3271A	85060311	July 07, 2006
HP Pre_Amplifier	8449B	3008A01922	Oct. 02, 2006
ROHDE & SCHWARZ Test Receiver	ESCS30	100375	Sep. 19, 2006
CHASE Broadband Antenna	VULB9168	138	Dec. 11, 2006
Schwarzbeck Horn_Antenna	BBHA9120	D124	Dec. 27, 2006
Schwarzbeck Horn_Antenna	BBHA 9170	BBHA9170153	Jan. 05, 2007
SCHWARZBECK Biconical Antenna	VHBA9123	459	Jun. 26, 2006
SCHWARZBECK Periodic Antenna	UPA6108	1148	Jun. 26, 2006
RF Switches (ARNITSU)	CS-201	1565157	NA
RF CABLE (Chaintek)	SF102	22054-2	Nov. 16, 2006
RF Cable(RICHTEC)	9913-30M N-N Cable	STCCAB-30M- 1GHz	Jul. 16, 2006
Software	ADT_Radiated_V 5.14	NA	NA
CHANCE MOST Antenna Tower	AT-100	0203	NA
CHANCE MOST Turn Table	TT-100	0203	NA

Note: 1. The calibration interval of the above test instruments is 12 months (36 months for Periodic Antenna) and the calibrations are traceable to NML/ROC and NIST/USA.

2. The horn antenna and HP preamplifier (model: 8449B) are used only for the measurement of emission frequency above 1GHz if tested.
3. The test was performed in ADT Open Site No. C.
4. The FCC Site Registration No. is 656396.
5. The VCCI Site Registration No. is R-1626.
6. The CANADA Site Registration No. is IC 4824-3.
7. The following table is for the measurement uncertainty, which is calculated as per the document CISPR 16-4. This uncertainty represents an expanded uncertainty expressed at approximately the 95% confidence level using a coverage factor of $k=2$.

Measurement	Value
Radiated emissions (30MHz-1GHz)	2.98 dB
Radiated emissions (1GHz ~18GHz)	2.21 dB
Radiated emissions (18GHz ~40GHz)	1.88 dB

4.1.3 TEST PROCEDURES

- a. The EUT was placed on the top of a rotating table 0.8 meters above the ground at a 3 meter semi- anechoic. The table was rotated 360 degrees to determine the position of the highest radiation.
- b. The EUT was set 3 meters away from the interference-receiving antenna, which was mounted on the top of a variable-height antenna tower.
- c. The antenna is a broadband antenna, and its height is varied from one meter to four meters above the ground to determine the maximum value of the field strength. Both horizontal and vertical polarizations of the antenna are set to make the measurement.
- d. For each suspected emission, the EUT was arranged to its worst case and then the antenna was tuned to heights from 1 meter to 4 meters and the rotatable table was turned from 0 degrees to 360 degrees to find the maximum reading.
- e. The test-receiver system was set to Peak Detect Function and Specified Bandwidth with Maximum Hold Mode.
- f. If the emission level of the EUT in peak mode was 10 dB lower than the limit specified, then testing could be stopped and the peak values of the EUT would be reported. Otherwise the emissions that did not have 10 dB margin would be re-tested one by one using the quasi-peak method or average method as specified and then reported in Data sheet peak mode and QP mode.

NOTE:

1. The resolution bandwidth and video bandwidth of test receiver/spectrum analyzer is 120kHz for Quasi-peak detection at frequency below 1GHz.
2. The resolution bandwidth and video bandwidth of test receiver/spectrum analyzer is 1 MHz for Peak detection (PK) at frequency above 1GHz.
3. The resolution bandwidth of test receiver/spectrum analyzer is 1 MHz and the video bandwidth is 10 Hz for Average detection (AV) at frequency above 1GHz.

4.1.4 DEVIATION FROM TEST STANDARD

No deviation

4.1.5 TEST SETUP

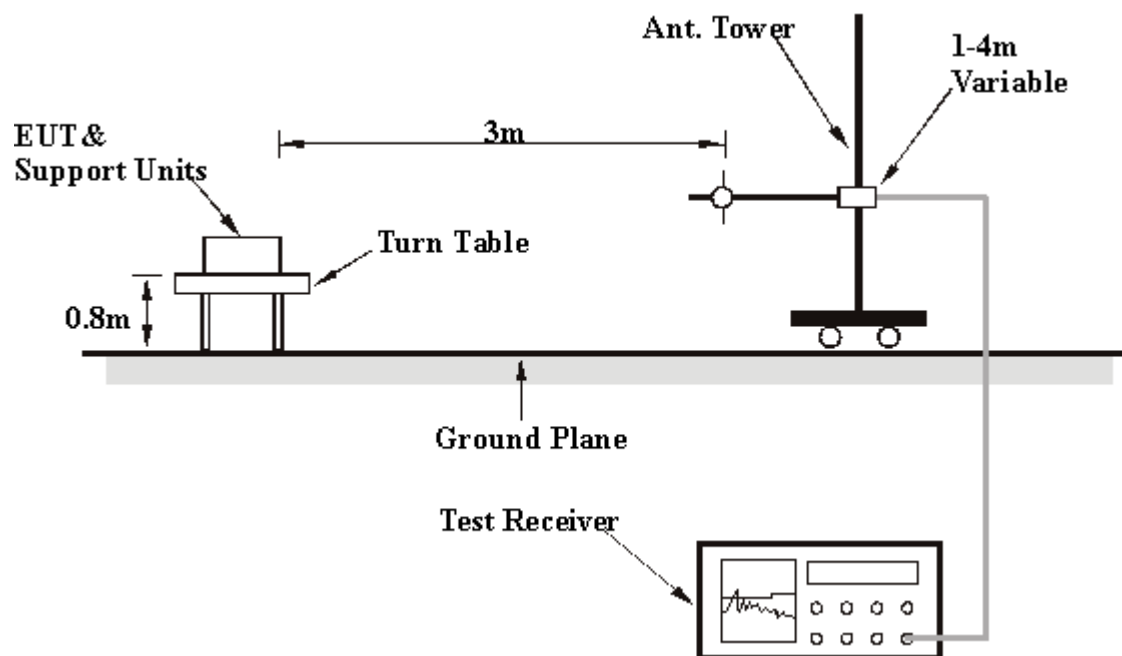

For the actual test configuration, please refer to the related item – Photographs of the Test Configuration.

4.1.6 EUT OPERATING CONDITIONS

- a. Placed the EUT on the testing table.
- b. Prepared another computer system to act as a communication partner and placed it outside of testing area.
- c. The communication partner run “Art 48b5” test program to enable EUT under transmission/receiving condition continuously at specific channel frequency via UTP cable and wireless.

4.1.7 TEST RESULTS

Below 1GHz Worst-Case Data

TEST MODE	With Adapter	FREQUENCY RANGE	30-1000 MHz
INPUT POWER (SYSTEM)	120Vac, 60Hz	DETECTOR FUNCTION & BANDWIDTH	Quasi-Peak, 120kHz
ENVIRONMENTAL CONDITIONS	27deg. C, 59%RH, 969 hPa	TESTED BY	Tony Chen

ANTENNA POLARITY & TEST DISTANCE: HORIZONTAL AT 3 M

No.	Freq. (MHz)	Emission Level (dBuV/m)	Limit (dBuV/m)	Margin (dB)	Antenna Height (m)	Table Angle (Degree)	Raw Value (dBuV)	Correction Factor (dB/m)
1	124.99	36.30 QP	43.50	-7.20	1.62 H	316	23.80	12.50
2	300.00	32.40 QP	46.00	-13.60	1.17 H	0	17.20	15.20
3	320.00	32.00 QP	46.00	-14.00	1.00 H	0	16.20	15.80
4	480.00	35.60 QP	46.00	-10.40	1.00 H	160	15.30	20.20
5	720.00	36.60 QP	46.00	-9.40	1.23 H	6	11.80	24.80
6	749.99	36.60 QP	46.00	-9.40	1.17 H	255	10.50	26.10
7	800.00	37.00 QP	46.00	-9.00	1.09 H	0	11.40	25.60
8	880.00	39.50 QP	46.00	-6.50	1.26 H	264	12.10	27.40
9	960.00	41.40 QP	46.00	-4.60	1.20 H	236	11.90	29.50

ANTENNA POLARITY & TEST DISTANCE: VERTICAL AT 3 M

No.	Freq. (MHz)	Emission Level (dBuV/m)	Limit (dBuV/m)	Margin (dB)	Antenna Height (m)	Table Angle (Degree)	Raw Value (dBuV)	Correction Factor (dB/m)
1	124.99	42.70 QP	43.50	-0.80	1.05 V	246	30.30	12.50
2	176.25	40.00 QP	43.50	-3.50	1.00 V	207	30.00	9.90
3	500.00	32.90 QP	46.00	-13.10	1.00 V	348	12.20	20.70
4	624.98	32.80 QP	46.00	-13.20	1.12 V	92	10.00	22.90
5	680.00	35.00 QP	46.00	-11.00	1.01 V	259	11.30	23.70
6	720.00	38.60 QP	46.00	-7.40	1.02 V	239	13.80	24.80
7	800.00	40.10 QP	46.00	-5.90	1.00 V	114	14.50	25.60
8	880.00	35.10 QP	46.00	-10.90	1.00 V	229	7.70	27.40
9	960.00	36.70 QP	46.00	-9.30	1.21 V	184	7.20	29.50

- REMARKS:**
1. Emission level(dBuV/m)=Raw Value(dBuV) + Correction Factor(dB)
 2. Correction Factor(dB/m) = Antenna Factor (dB/m) + Cable Factor (dB)
 3. The other emission levels were very low against the limit.
 4. Margin value = Emission level – Limit value.

TEST MODE	With Adapter+POE	FREQUENCY RANGE	30-1000 MHz
INPUT POWER (SYSTEM)	120Vac, 60Hz	DETECTOR FUNCTION & BANDWIDTH	Quasi-Peak, 120kHz
ENVIRONMENTAL CONDITIONS	27deg. C, 59%RH, 969 hPa	TESTED BY	Tony Chen

ANTENNA POLARITY & TEST DISTANCE: HORIZONTAL AT 3 M

No.	Freq. (MHz)	Emission Level (dBuV/m)	Limit (dBuV/m)	Margin (dB)	Antenna Height (m)	Table Angle (Degree)	Raw Value (dBuV)	Correction Factor (dB/m)
1	124.99	40.90 QP	43.50	-2.60	2.62 H	339	28.40	12.50
2	174.99	32.90 QP	43.50	-10.60	2.37 H	0	22.90	10.10
3	320.00	34.70 QP	46.00	-11.30	1.00 H	359	18.90	15.80
4	439.99	40.10 QP	46.00	-5.90	1.00 H	262	20.80	19.30
5	749.98	34.30 QP	46.00	-11.70	1.17 H	267	8.20	26.10
6	760.00	39.60 QP	46.00	-6.40	1.08 H	37	13.60	26.00
7	800.00	32.50 QP	46.00	-13.50	1.11 H	23	6.90	25.60
8	839.99	34.00 QP	46.00	-12.00	1.00 H	30	7.10	26.90
9	879.99	43.30 QP	46.00	-2.70	1.00 H	4	16.00	27.40
10	919.99	34.60 QP	46.00	-11.40	1.00 H	5	6.30	28.30
11	959.99	35.70 QP	46.00	-10.30	1.00 H	348	6.30	29.50

ANTENNA POLARITY & TEST DISTANCE: VERTICAL AT 3 M

No.	Freq. (MHz)	Emission Level (dBuV/m)	Limit (dBuV/m)	Margin (dB)	Antenna Height (m)	Table Angle (Degree)	Raw Value (dBuV)	Correction Factor (dB/m)
1	79.99	34.10 QP	40.00	-5.90	1.00 V	95	26.10	8.00
2	124.99	42.40 QP	43.50	-1.10	2.42 V	22	29.90	12.50
3	175.00	40.90 QP	43.50	-2.60	1.00 V	68	30.80	10.10
4	249.99	30.20 QP	46.00	-15.80	1.00 V	171	16.20	14.00
5	500.04	34.80 QP	46.00	-11.20	1.00 V	68	14.10	20.70
6	550.00	30.80 QP	46.00	-15.20	1.24 V	103	8.00	22.80
7	624.98	31.30 QP	46.00	-14.70	1.00 V	233	8.40	22.90
8	749.98	34.00 QP	46.00	-12.00	1.00 V	181	7.90	26.10
9	759.99	38.70 QP	46.00	-7.30	1.44 V	3	12.60	26.00
10	839.99	32.30 QP	46.00	-13.70	1.70 V	223	5.40	26.90
11	879.99	33.70 QP	46.00	-12.30	1.26 V	22	6.30	27.40

- REMARKS:**
1. Emission level(dBuV/m)=Raw Value(dBuV) + Correction Factor(dB)
 2. Correction Factor(dB/m) = Antenna Factor (dB/m) + Cable Factor (dB)
 3. The other emission levels were very low against the limit.
 4. Margin value = Emission level – Limit value.

802.11b DSSS modulation

MODE	Channel 1	FREQUENCY RANGE	1000MHz~25000MHz
INPUT POWER (SYSTEM)	120Vac, 60Hz	DETECTOR FUNCTION & BANDWIDTH	Peak (PK) Average (AV) 1 MHz
ENVIRONMENTAL CONDITIONS	27deg. C, 57%RH, 969 hPa	TESTED BY	Tony Chen

ANTENNA POLARITY & TEST DISTANCE: HORIZONTAL AT 3 M

No.	Freq. (MHz)	Emission Level (dBuV/m)	Limit (dBuV/m)	Margin (dB)	Antenna Height (m)	Table Angle (Degree)	Raw Value (dBuV)	Correction Factor (dB/m)
1	2390.00	55.40 PK	74.00	-18.60	1.43 H	13	21.70	33.70
1	2390.00	43.00 AV	54.00	-11.00	1.43 H	13	9.30	33.70
2	*2412.00	107.20 PK			1.43 H	13	77.40	29.80
2	*2412.00	99.60 AV			1.43 H	13	69.80	29.80
3	2688.00	46.70 PK	74.00	-27.30	1.03 H	12	15.80	30.90
3	2688.00	43.00 AV	54.00	-11.00	1.03 H	12	12.10	30.90
4	4824.00	51.40 PK	74.00	-22.60	1.11 H	333	16.30	35.10
4	4824.00	39.00 AV	54.00	-15.00	1.11 H	333	3.90	35.10
5	7236.00	49.90 PK	74.00	-24.10	1.29 H	296	9.40	40.50
5	7236.00	39.60 AV	54.00	-14.40	1.29 H	296	-0.90	40.50

ANTENNA POLARITY & TEST DISTANCE: VERTICAL AT 3 M

No.	Freq. (MHz)	Emission Level (dBuV/m)	Limit (dBuV/m)	Margin (dB)	Antenna Height (m)	Table Angle (Degree)	Raw Value (dBuV)	Correction Factor (dB/m)
1	2390.00	50.50 PK	74.00	-23.50	1.09 V	357	16.80	33.70
1	2390.00	38.60 AV	54.00	-15.40	1.09 V	357	4.90	33.70
2	*2412.00	102.30 PK			1.09 V	357	72.50	29.80
2	*2412.00	95.20 AV			1.09 V	357	65.40	29.80
3	2688.00	42.60 PK	74.00	-31.40	1.00 V	11	11.70	30.90
3	2688.00	36.20 AV	54.00	-17.80	1.00 V	11	5.30	30.90
4	4824.00	53.40 PK	74.00	-20.60	1.08 V	113	18.30	35.10
4	4824.00	41.60 AV	54.00	-12.40	1.08 V	113	6.50	35.10
5	7236.00	50.80 PK	74.00	-23.20	1.11 V	99	10.30	40.50
5	7236.00	42.40 AV	54.00	-11.60	1.11 V	99	1.90	40.50

- NOTE:**
1. Emission level(dBuV/m)=Raw Value(dBuV) + Correction Factor(dB)
 2. Correction Factor(dB/m) = Antenna Factor (dB/m) + Cable Factor (dB)
 3. The other emission levels were very low against the limit.
 4. Margin value = Emission level – Limit value.
 5. The limit value is defined as per 15.247
 6. “ * “ : Fundamental frequency

MODE	Channel 6	FREQUENCY RANGE	1000MHz~25000MHz
INPUT POWER (SYSTEM)	120Vac, 60Hz	DETECTOR FUNCTION & BANDWIDTH	Peak (PK) Average (AV) 1 MHz
ENVIRONMENTAL CONDITIONS	27deg. C, 57%RH, 969 hPa	TESTED BY	Tony Chen

ANTENNA POLARITY & TEST DISTANCE: HORIZONTAL AT 3 M

No.	Freq. (MHz)	Emission Level (dBuV/m)	Limit (dBuV/m)	Margin (dB)	Antenna Height (m)	Table Angle (Degree)	Raw Value (dBuV)	Correction Factor (dB/m)
1	*2437.00	106.20 PK			1.42 H	23	76.30	29.90
1	*2437.00	99.10 AV			1.42 H	23	69.20	29.90
2	2688.00	46.90 PK	74.00	-27.10	1.04 H	17	16.00	30.90
2	2688.00	43.30 AV	54.00	-10.70	1.04 H	17	12.40	30.90
3	4874.00	50.50 PK	74.00	-23.50	1.09 H	332	15.20	35.30
3	4874.00	38.70 AV	54.00	-15.30	1.09 H	332	3.40	35.30
4	7311.00	49.50 PK	74.00	-24.50	1.31 H	301	8.80	40.70
4	7311.00	39.10 AV	54.00	-14.90	1.31 H	301	-1.60	40.70

ANTENNA POLARITY & TEST DISTANCE: VERTICAL AT 3 M

No.	Freq. (MHz)	Emission Level (dBuV/m)	Limit (dBuV/m)	Margin (dB)	Antenna Height (m)	Table Angle (Degree)	Raw Value (dBuV)	Correction Factor (dB/m)
1	*2437.00	101.60 PK			1.05 V	352	71.70	29.90
1	*2437.00	94.40 AV			1.05 V	352	64.50	29.90
2	2688.00	43.30 PK	74.00	-30.70	1.00 V	10	12.40	30.90
2	2688.00	37.00 AV	54.00	-17.00	1.00 V	10	6.10	30.90
3	4874.00	54.70 PK	74.00	-19.30	1.07 V	114	19.40	35.30
3	4874.00	42.80 AV	54.00	-11.20	1.07 V	114	7.50	35.30
4	7311.00	50.80 PK	74.00	-23.20	1.12 V	103	10.10	40.70
4	7311.00	42.20 AV	54.00	-11.80	1.12 V	103	1.50	40.70

- NOTE:**
1. Emission level(dBuV/m)=Raw Value(dBuV) + Correction Factor(dB)
 2. Correction Factor(dB/m) = Antenna Factor (dB/m) + Cable Factor (dB)
 3. The other emission levels were very low against the limit.
 4. Margin value = Emission level – Limit value.
 5. The limit value is defined as per 15.247
 6. “ * ” : Fundamental frequency

MODE	Channel 11	FREQUENCY RANGE	1000MHz~25000MHz
INPUT POWER (SYSTEM)	120Vac, 60Hz	DETECTOR FUNCTION & BANDWIDTH	Peak (PK) Average (AV) 1 MHz
ENVIRONMENTAL CONDITIONS	27deg. C, 57%RH, 969 hPa	TESTED BY	Tony Chen

ANTENNA POLARITY & TEST DISTANCE: HORIZONTAL AT 3M

No.	Freq. (MHz)	Emission Level (dBuV/m)	Limit (dBuV/m)	Margin (dB)	Antenna Height (m)	Table Angle (Degree)	Raw Value (dBuV)	Correction Factor (dB/m)
1	*2462.00	106.00 PK			1.41 H	25	76.00	30.00
1	*2462.00	98.90 AV			1.41 H	25	68.90	30.00
2	2483.50	50.90 PK	74.00	-23.10	1.41 H	25	20.80	30.10
2	2483.50	41.50 AV	54.00	-12.50	1.41 H	25	11.40	30.10
3	2688.00	47.00 PK	74.00	-27.00	1.05 H	14	16.10	30.90
3	2688.00	43.50 AV	54.00	-10.50	1.05 H	14	12.60	30.90
4	4924.00	50.50 PK	74.00	-23.50	1.10 H	332	14.90	35.50
4	4924.00	38.50 AV	54.00	-15.50	1.10 H	332	2.90	35.50
5	7386.00	49.50 PK	74.00	-24.50	1.28 H	321	8.70	40.80
5	7386.00	38.90 AV	54.00	-15.10	1.28 H	321	-1.90	40.80

ANTENNA POLARITY & TEST DISTANCE: VERTICAL AT 3M

No.	Freq. (MHz)	Emission Level (dBuV/m)	Limit (dBuV/m)	Margin (dB)	Antenna Height (m)	Table Angle (Degree)	Raw Value (dBuV)	Correction Factor (dB/m)
1	*2462.00	101.30 PK			1.08 V	350	71.30	30.00
1	*2462.00	94.10 AV			1.08 V	350	64.10	30.00
2	2483.50	46.20 PK	74.00	-27.80	1.08 V	350	16.10	30.10
2	2483.50	36.70 AV	54.00	-17.30	1.08 V	350	6.60	30.10
3	2688.00	43.60 PK	74.00	-30.40	1.00 V	14	12.70	30.90
3	2688.00	37.10 AV	54.00	-16.90	1.00 V	14	6.20	30.90
4	4924.00	54.40 PK	74.00	-19.60	1.09 V	115	18.80	35.50
4	4924.00	42.60 AV	54.00	-11.40	1.09 V	115	7.00	35.50
5	7386.00	50.70 PK	74.00	-23.30	1.10 V	97	9.90	40.80
5	7386.00	41.80 AV	54.00	-12.20	1.10 V	97	1.00	40.80

- NOTE:**
1. Emission level(dBuV/m)=Raw Value(dBuV) + Correction Factor(dB)
 2. Correction Factor(dB/m) = Antenna Factor (dB/m) + Cable Factor (dB)
 3. The other emission levels were very low against the limit.
 4. Margin value = Emission level – Limit value.
 5. The limit value is defined as per 15.247
 6. “ * ” : Fundamental frequency

802.11g OFDM modulation

MODE	Channel 1	FREQUENCY RANGE	1000MHz~25000MHz
INPUT POWER (SYSTEM)	120Vac, 60Hz	DETECTOR FUNCTION & BANDWIDTH	Peak (PK) Average (AV) 1 MHz
ENVIRONMENTAL CONDITIONS	27deg. C, 57%RH, 969 hPa	TESTED BY	Tony Chen

ANTENNA POLARITY & TEST DISTANCE: HORIZONTAL AT 3 M

No.	Freq. (MHz)	Emission Level (dBuV/m)	Limit (dBuV/m)	Margin (dB)	Antenna Height (m)	Table Angle (Degree)	Raw Value (dBuV)	Correction Factor (dB/m)
1	2390.00	53.30 PK	74.00	-20.70	1.41 H	15	19.60	33.70
1	2390.00	45.30 AV	54.00	-8.70	1.41 H	15	11.60	33.70
2	*2412.00	101.50 PK			1.41 H	15	71.70	29.80
2	*2412.00	93.40 AV			1.41 H	15	63.60	29.80
3	2688.00	47.30 PK	74.00	-26.70	1.04 H	11	16.40	30.90
3	2688.00	44.60 AV	54.00	-9.40	1.04 H	11	13.70	30.90
4	4824.00	44.70 PK	74.00	-29.30	1.13 H	333	9.60	35.10
4	4824.00	32.80 AV	54.00	-21.20	1.13 H	333	-2.30	35.10
5	7236.00	47.90 PK	74.00	-26.10	1.27 H	304	7.40	40.50
5	7236.00	36.70 AV	54.00	-17.30	1.27 H	304	-3.80	40.50

ANTENNA POLARITY & TEST DISTANCE: VERTICAL AT 3 M

No.	Freq. (MHz)	Emission Level (dBuV/m)	Limit (dBuV/m)	Margin (dB)	Antenna Height (m)	Table Angle (Degree)	Raw Value (dBuV)	Correction Factor (dB/m)
1	2390.00	49.00 PK	74.00	-25.00	1.08 V	356	15.30	33.70
1	2390.00	40.00 AV	54.00	-14.00	1.08 V	356	6.30	33.70
2	*2412.00	97.20 PK			1.08 V	356	67.40	29.80
2	*2412.00	88.10 AV			1.08 V	356	58.30	29.80
3	2688.00	42.20 PK	74.00	-31.80	1.00 V	12	11.30	30.90
3	2688.00	33.00 AV	54.00	-21.00	1.00 V	12	2.10	30.90
4	4824.00	47.50 PK	74.00	-26.50	1.07 V	112	12.40	35.10
4	4824.00	34.20 AV	54.00	-19.80	1.07 V	112	-0.90	35.10
5	7236.00	48.90 PK	74.00	-25.10	1.09 V	97	8.40	40.50
5	7236.00	37.50 AV	54.00	-16.50	1.09 V	97	-3.00	40.50

- NOTE:**
1. Emission level(dBuV/m)=Raw Value(dBuV) + Correction Factor(dB)
 2. Correction Factor(dB/m) = Antenna Factor (dB/m) + Cable Factor (dB)
 3. The other emission levels were very low against the limit.
 4. Margin value = Emission level – Limit value.
 5. The limit value is defined as per 15.247
 6. “ * “ : Fundamental frequency

MODE	Channel 6	FREQUENCY RANGE	1000MHz~25000MHz
INPUT POWER (SYSTEM)	120Vac, 60Hz	DETECTOR FUNCTION & BANDWIDTH	Peak (PK) Average (AV) 1 MHz
ENVIRONMENTAL CONDITIONS	27deg. C, 57%RH, 969 hPa	TESTED BY	Tony Chen

ANTENNA POLARITY & TEST DISTANCE: HORIZONTAL AT 3 M

No.	Freq. (MHz)	Emission Level (dBuV/m)	Limit (dBuV/m)	Margin (dB)	Antenna Height (m)	Table Angle (Degree)	Raw Value (dBuV)	Correction Factor (dB/m)
1	*2437.00	101.30 PK			1.42 H	21	71.40	29.90
1	*2437.00	92.60 AV			1.42 H	21	62.70	29.90
2	2688.00	47.90 PK	74.00	-26.10	1.03 H	14	17.00	30.90
2	2688.00	44.70 AV	54.00	-9.30	1.03 H	14	13.80	30.90
3	4874.00	44.90 PK	74.00	-29.10	1.08 H	331	9.60	35.30
3	4874.00	33.40 AV	54.00	-20.60	1.08 H	331	-1.90	35.30
4	7311.00	47.90 PK	74.00	-26.10	1.33 H	314	7.20	40.70
4	7311.00	36.60 AV	54.00	-17.40	1.33 H	314	-4.10	40.70

ANTENNA POLARITY & TEST DISTANCE: VERTICAL AT 3 M

No.	Freq. (MHz)	Emission Level (dBuV/m)	Limit (dBuV/m)	Margin (dB)	Antenna Height (m)	Table Angle (Degree)	Raw Value (dBuV)	Correction Factor (dB/m)
1	*2437.00	96.40 PK			1.06 V	353	66.50	29.90
1	*2437.00	87.60 AV			1.06 V	353	57.70	29.90
2	2688.00	41.70 PK	74.00	-32.30	1.00 V	11	10.80	30.90
2	2688.00	33.20 AV	54.00	-20.80	1.00 V	11	2.30	30.90
3	4874.00	47.30 PK	74.00	-26.70	1.08 V	112	12.00	35.30
3	4874.00	35.10 AV	54.00	-18.90	1.08 V	112	-0.20	35.30
4	7311.00	49.20 PK	74.00	-24.80	1.09 V	115	8.50	40.70
4	7311.00	37.60 AV	54.00	-16.40	1.09 V	115	-3.10	40.70

- NOTE:**
1. Emission level(dBuV/m)=Raw Value(dBuV) + Correction Factor(dB)
 2. Correction Factor(dB/m) = Antenna Factor (dB/m) + Cable Factor (dB)
 3. The other emission levels were very low against the limit.
 4. Margin value = Emission level – Limit value.
 5. The limit value is defined as per 15.247
 6. “ * “ : Fundamental frequency

MODE	Channel 11	FREQUENCY RANGE	1000MHz~25000MHz
INPUT POWER (SYSTEM)	120Vac, 60Hz	DETECTOR FUNCTION & BANDWIDTH	Peak (PK) Average (AV) 1 MHz
ENVIRONMENTAL CONDITIONS	27deg. C, 57%RH, 969 hPa	TESTED BY	Tony Chen

ANTENNA POLARITY & TEST DISTANCE: HORIZONTAL AT 3M								
No.	Freq. (MHz)	Emission Level (dBuV/m)	Limit (dBuV/m)	Margin (dB)	Antenna Height (m)	Table Angle (Degree)	Raw Value (dBuV)	Correction Factor (dB/m)
1	*2462.00	101.20 PK			1.40 H	24	71.20	30.00
1	*2462.00	92.90 AV			1.40 H	24	62.90	30.00
2	2483.50	53.10 PK	74.00	-20.90	1.40 H	24	23.00	30.10
2	2483.50	43.00 AV	54.00	-11.00	1.40 H	24	12.90	30.10
3	2688.00	47.70 PK	74.00	-26.30	1.05 H	16	16.80	30.90
3	2688.00	44.10 AV	54.00	-9.90	1.05 H	16	13.20	30.90
4	4924.00	45.00 PK	74.00	-29.00	1.11 H	336	9.40	35.50
4	4924.00	33.40 AV	54.00	-20.60	1.11 H	336	-2.20	35.50
5	7386.00	48.40 PK	74.00	-25.60	1.29 H	317	7.60	40.80
5	7386.00	36.90 AV	54.00	-17.10	1.29 H	317	-3.90	40.80

ANTENNA POLARITY & TEST DISTANCE: VERTICAL AT 3M								
No.	Freq. (MHz)	Emission Level (dBuV/m)	Limit (dBuV/m)	Margin (dB)	Antenna Height (m)	Table Angle (Degree)	Raw Value (dBuV)	Correction Factor (dB/m)
1	*2462.00	96.30 PK			1.07 V	351	66.30	30.00
1	*2462.00	87.60 AV			1.07 V	351	57.60	30.00
2	2483.50	48.20 PK	74.00	-25.80	1.07 V	351	18.10	30.10
2	2483.50	37.70 AV	54.00	-16.30	1.07 V	351	7.60	30.10
3	2688.00	42.40 PK	74.00	-31.60	1.00 V	9	11.50	30.90
3	2688.00	33.50 AV	54.00	-20.50	1.00 V	9	2.60	30.90
4	4924.00	47.30 PK	74.00	-26.70	1.06 V	115	11.70	35.50
4	4924.00	34.50 AV	54.00	-19.50	1.06 V	115	-1.10	35.50
5	7386.00	49.10 PK	74.00	-24.90	1.10 V	96	8.30	40.80
5	7386.00	38.00 AV	54.00	-16.00	1.10 V	96	-2.80	40.80

- NOTE:**
1. Emission level(dBuV/m)=Raw Value(dBuV) + Correction Factor(dB)
 2. Correction Factor(dB/m) = Antenna Factor (dB/m) + Cable Factor (dB)
 3. The other emission levels were very low against the limit.
 4. Margin value = Emission level – Limit value.
 5. The limit value is defined as per 15.247
 6. “ * “ : Fundamental frequency

802.11g Turbo OFDM modulation

MODE	Turbo Channel 6	FREQUENCY RANGE	1000MHz~25000MHz
INPUT POWER (SYSTEM)	120Vac, 60Hz	DETECTOR FUNCTION & BANDWIDTH	Peak (PK) Average (AV) 1 MHz
ENVIRONMENTAL CONDITIONS	27deg. C, 57%RH, 969 hPa	TESTED BY	Tony Chen

ANTENNA POLARITY & TEST DISTANCE: HORIZONTAL AT 3M

No.	Freq. (MHz)	Emission Level (dBuV/m)	Limit (dBuV/m)	Margin (dB)	Antenna Height (m)	Table Angle (Degree)	Raw Value (dBuV)	Correction Factor (dB/m)
1	2390.00	50.20 PK	74.00	-23.80	1.42 H	22	16.50	33.70
1	2390.00	40.50 AV	54.00	-13.50	1.42 H	22	6.80	33.70
2	*2437.00	97.90 PK			1.42 H	22	68.00	29.90
2	*2437.00	89.60 AV			1.42 H	22	59.70	29.90
3	2483.50	48.40 PK	74.00	-25.60	1.42 H	22	18.30	30.10
3	2483.50	38.30 AV	54.00	-15.70	1.42 H	22	8.20	30.10
4	2688.00	47.70 PK	74.00	-26.30	1.04 H	13	16.80	30.90
4	2688.00	44.40 AV	54.00	-9.60	1.04 H	13	13.50	30.90
5	4874.00	43.40 PK	74.00	-30.60	1.09 H	334	8.10	35.30
5	4874.00	32.00 AV	54.00	-22.00	1.09 H	334	-3.30	35.30
6	7311.00	47.80 PK	74.00	-26.20	1.34 H	312	7.10	40.70
6	7311.00	36.40 AV	54.00	-17.60	1.34 H	312	-4.30	40.70

ANTENNA POLARITY & TEST DISTANCE: VERTICAL AT 3M

No.	Freq. (MHz)	Emission Level (dBuV/m)	Limit (dBuV/m)	Margin (dB)	Antenna Height (m)	Table Angle (Degree)	Raw Value (dBuV)	Correction Factor (dB/m)
1	2390.00	45.90 PK	74.00	-28.10	1.06 V	354	12.20	33.70
1	2390.00	36.20 AV	54.00	-17.80	1.06 V	354	2.50	33.70
2	*2437.00	93.60 PK			1.06 V	354	63.70	29.90
2	*2437.00	85.30 AV			1.06 V	354	55.40	29.90
3	2483.50	44.10 PK	74.00	-29.90	1.06 V	354	14.00	30.10
3	2483.50	34.00 AV	54.00	-20.00	1.06 V	354	3.90	30.10
4	2688.00	41.80 PK	74.00	-32.20	1.00 V	13	10.90	30.90
4	2688.00	33.00 AV	54.00	-21.00	1.00 V	13	2.10	30.90
5	4874.00	45.30 PK	74.00	-28.70	1.07 V	114	10.00	35.30
5	4874.00	33.90 AV	54.00	-20.10	1.07 V	114	-1.40	35.30
6	7311.00	48.70 PK	74.00	-25.30	1.12 V	106	8.00	40.70
6	7311.00	37.20 AV	54.00	-16.80	1.12 V	106	-3.50	40.70

- NOTE:**
1. Emission level(dBuV/m)=Raw Value(dBuV) + Correction Factor(dB)
 2. Correction Factor(dB/m) = Antenna Factor (dB/m) + Cable Factor (dB)
 3. The other emission levels were very low against the limit.
 4. Margin value = Emission level – Limit value.
 5. The limit value is defined as per 15.247
 6. “ * “ : Fundamental frequency



4.2 MAXIMUM PEAK OUTPUT POWER

4.2.1 LIMITS OF MAXIMUM PEAK OUTPUT POWER MEASUREMENT

The Maximum Peak Output Power Measurement is 30dBm.

4.2.2 INSTRUMENTS

Description & Manufacturer	Model No.	Serial No.	Calibrated Until
R&S SPECTRUM ANALYZER	FSP40	100036	Nov. 23, 2006
Agilent SIGNAL GENERATOR	E8257C	MY43320668	Dec. 07, 2006
TEKTRONIX OSCILLOSCOPE	TDS380	B016335	Jun. 22, 2006
NARDA DETECTOR	4503A	FSCM99899	NA

NOTE:

The calibration interval of the above test instruments is 12 months and the calibrations are traceable to NML/ROC and NIST/USA.

4.2.3 TEST PROCEDURES

1. A detector was used on the output port of the EUT. An oscilloscope was used to read the response of the detector.
2. Replaced the EUT by the signal generator. The center frequency of the S.G was adjusted to the center frequency of the measured channel.
3. Adjusted the power to have the same reading on oscilloscope. Record the power level.

4.2.4 DEVIATION FROM TEST STANDARD

No deviation

4.2.5 TEST SETUP



4.2.6 EUT OPERATING CONDITIONS

Same as Item 4.1.6



4.2.7 TEST RESULTS

802.11b DSSS modulation

MODULATION TYPE	CCK	TRANSFER RATE	11Mbps
INPUT POWER (SYSTEM)	120Vac, 60Hz	ENVIRONMENTAL CONDITIONS	24deg. C, 64%RH, 969hPa
TESTED BY	Sky Liao		

CHANNEL	CHANNEL FREQUENCY (MHz)	PEAK POWER OUTPUT (mW)	PEAK POWER OUTPUT (dBm)	PEAK POWER LIMIT (dBm)	PASS/FAIL
1	2412	39.902	16.01	30	PASS
6	2437	40.738	16.10	30	PASS
11	2462	40.551	16.08	30	PASS



802.11g OFDM modulation

MODULATION TYPE	BPSK	TRANSFER RATE	6Mbps
INPUT POWER (SYSTEM)	120Vac, 60Hz	ENVIRONMENTAL CONDITIONS	24deg. C, 64%RH, 969hPa
TESTED BY	Sky Liao		

CHANNEL	CHANNEL FREQUENCY (MHz)	PEAK POWER OUTPUT (mW)	PEAK POWER OUTPUT (dBm)	PEAK POWER LIMIT (dBm)	PASS/FAIL
1	2412	48.978	16.90	30	PASS
6	2437	41.687	16.20	30	PASS
11	2462	40.739	16.10	30	PASS

802.11g Turbo OFDM modulation

MODULATION TYPE	BPSK	TRANSFER RATE	12Mbps
INPUT POWER (SYSTEM)	120Vac, 60Hz	ENVIRONMENTAL CONDITIONS	24deg. C, 64%RH, 969hPa
TESTED BY	Sky Liao		

CHANNEL	CHANNEL FREQUENCY (MHz)	PEAK POWER OUTPUT (mW)	PEAK POWER OUTPUT (dBm)	PEAK POWER LIMIT (dBm)	PASS/FAIL
6	2437	41.021	16.13	30	PASS

4.3 BAND EDGES MEASUREMENT

4.3.1 LIMITS OF BAND EDGES MEASUREMENT

Below -20dB of the highest emission level of operating band (in 100kHz Resolution Bandwidth).

4.3.2 TEST INSTRUMENTS

Description & Manufacturer	Model No.	Serial No.	Calibrated Until
R&S SPECTRUM ANALYZER	FSP40	100036	Nov. 23, 2006

NOTE:

- 1.The measurement uncertainty is less than $\pm 2.6\text{dB}$, which is calculated as per the NAMAS document NIS81.
- 2.The calibration interval of the above test instruments is 12 months and the calibrations are traceable to NML/ROC and NIST/USA.

4.3.3 TEST PROCEDURE

The transmitter output was connected to the spectrum analyzer via a low lose cable. Set RBW spectrum analyzer to 1 MHz and set VBW spectrum analyzer to 10 Hz with suitable frequency span including 100MHz bandwidth from band edge. The band edges was measured and recorded.

The spectrum plots (Peak RBW=VBW=100kHz ; Average RBW=1MHz, VBW=10Hz) are attached on the following pages.

4.3.4 DEVIATION FROM TEST STANDARD

No deviation

4.3.5 EUT OPERATING CONDITION

Same as Item 4.1.6

4.3.6 TEST RESULTS

The spectrum plots are attached on the following 2 pages. D1 line indicates the highest level, and D2 line indicates the 20dB offset below D2. It shows compliance with the requirement in part 15.247(C).

Note - The delta method is only used up to 2 MHz away from the restricted bandage, The radiated emissions which located in other restricted frequency band, the result, please refer to 4.2.

802.11b DSSS modulation

NOTE (Peak):

The band edge emission plot of DSSS technique on the following pages show 51.80dB delta between carrier maximum power and local maximum emission in restrict band (2.3900GHz). The emission of carrier strength list in the test result of channel 1 at the item 4.2 is 107.2dBuV/m, so the maximum field strength in restrict band is $107.2-51.80=55.40$ dBuV/m which is under 74 dBuV/m limit.

The band edge emission plot of DSSS technique on the following pages shows 55.13dB delta between carrier maximum power and local maximum emission in restrict band (2.4835GHz). The emission of carrier strength list in the test result of channel 11 at the item 4.2 is 106.0dBuV/m, so the maximum field strength in restrict band is $106.0-55.13=50.87$ dBuV/m which is under 74 dBuV/m limit.

NOTE (Average):

The band edge emission plot of DSSS technique on the following pages shows 56.58dB delta between carrier maximum power and local maximum emission in restrict band (2.3900GHz). The emission of carrier strength list in the test result of channel 1 at the item 4.2 is 99.60dBuV/m, so the maximum field strength in restrict band is $99.60-56.58=43.02$ dBuV/m which is under 54 dBuV/m limit.

The band edge emission plot of DSSS technique on the following pages shows 57.38dB delta between carrier maximum power and local maximum emission in restrict band (2.4835GHz). The emission of carrier strength list in the test result of channel 11 at the item 4.2 is 98.90dBuV/m, so the maximum field strength in restrict band is $98.90-57.38=41.52$ dBuV/m which is under 54 dBuV/m limit.

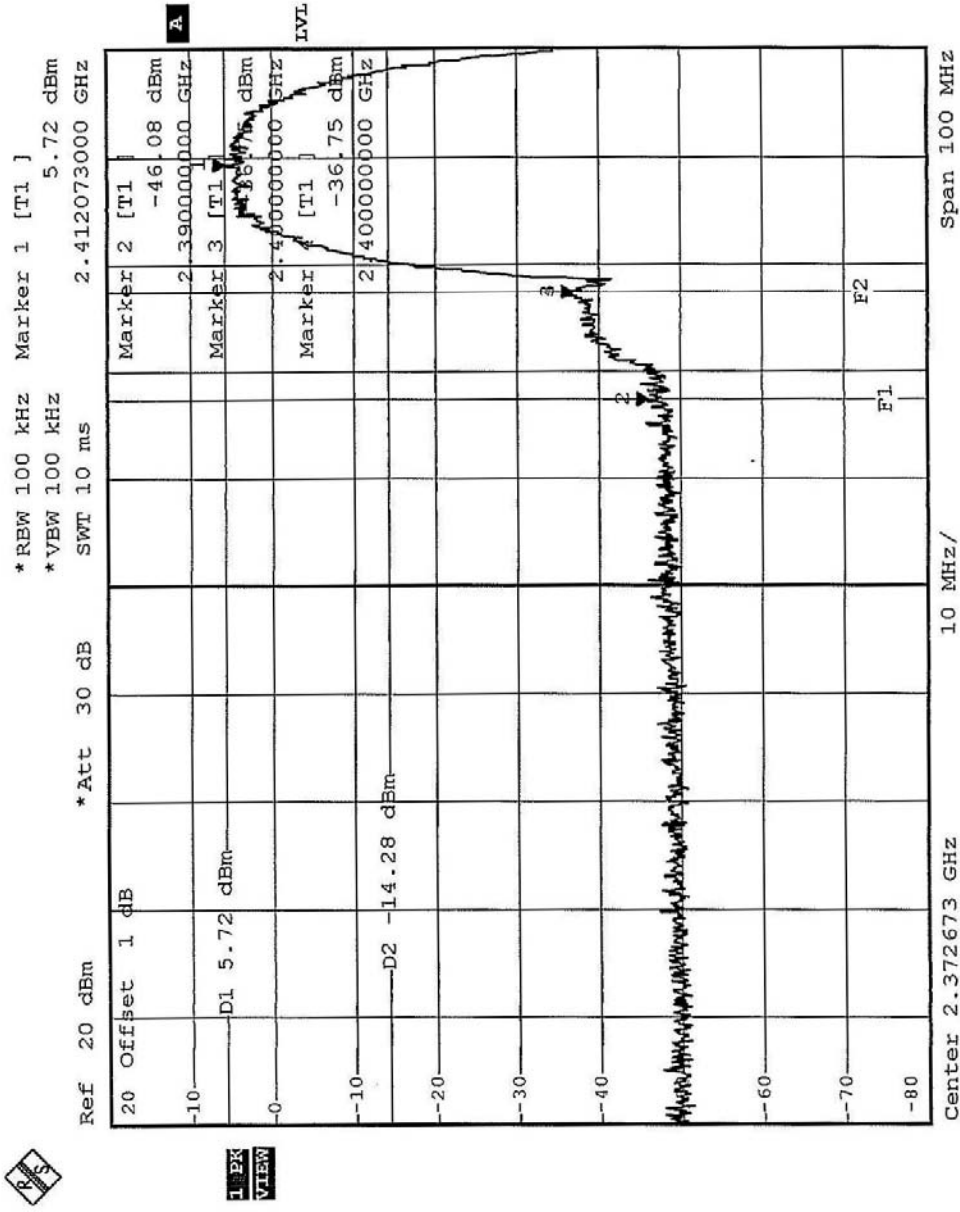

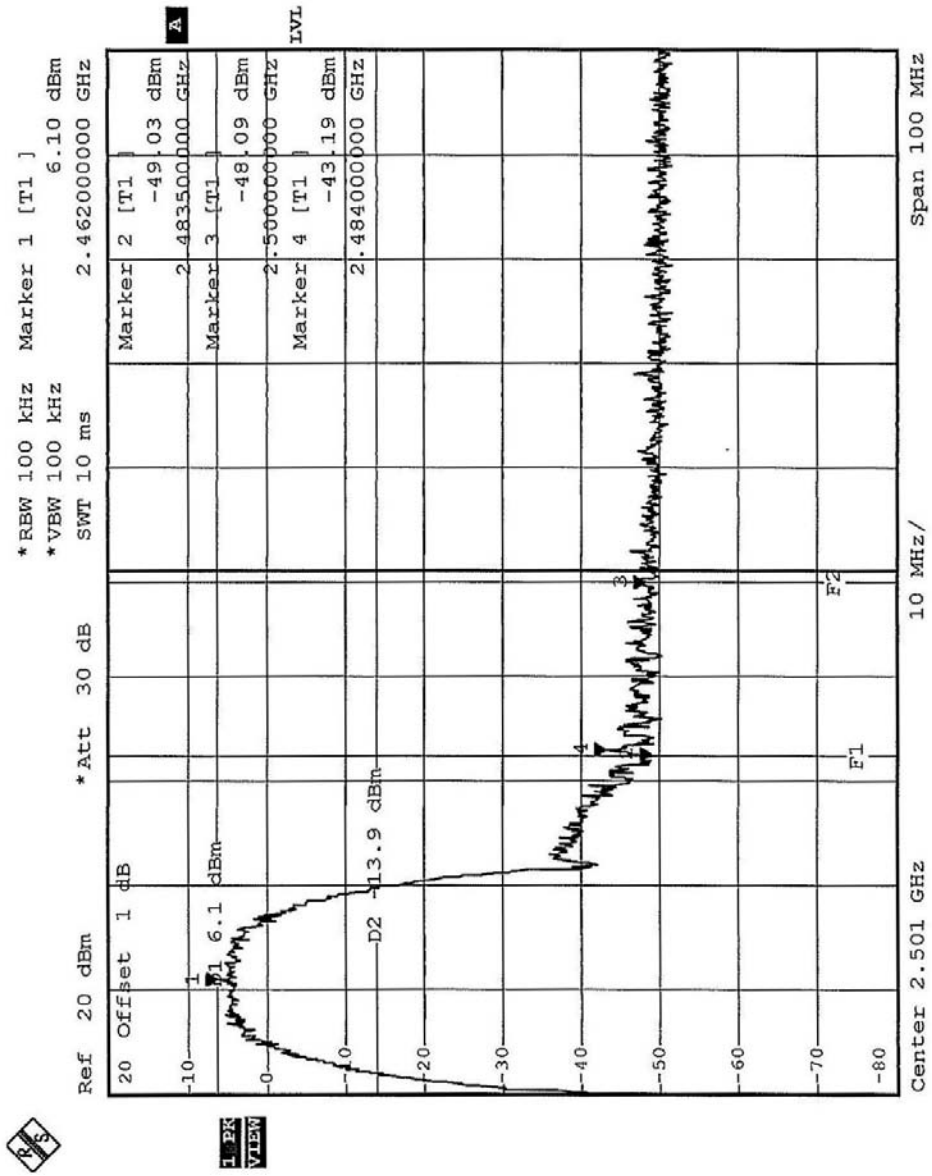

CH 1

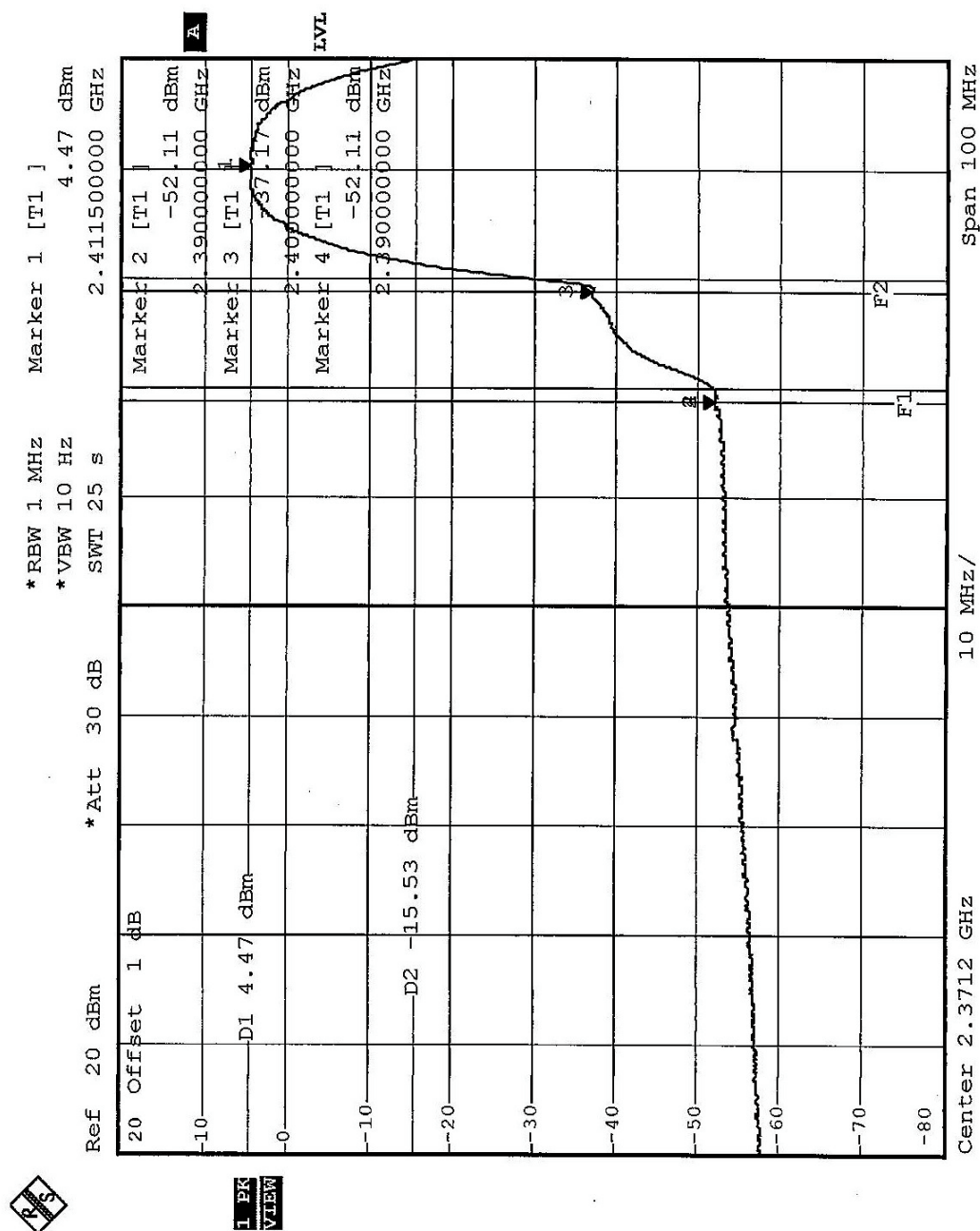

CH 11

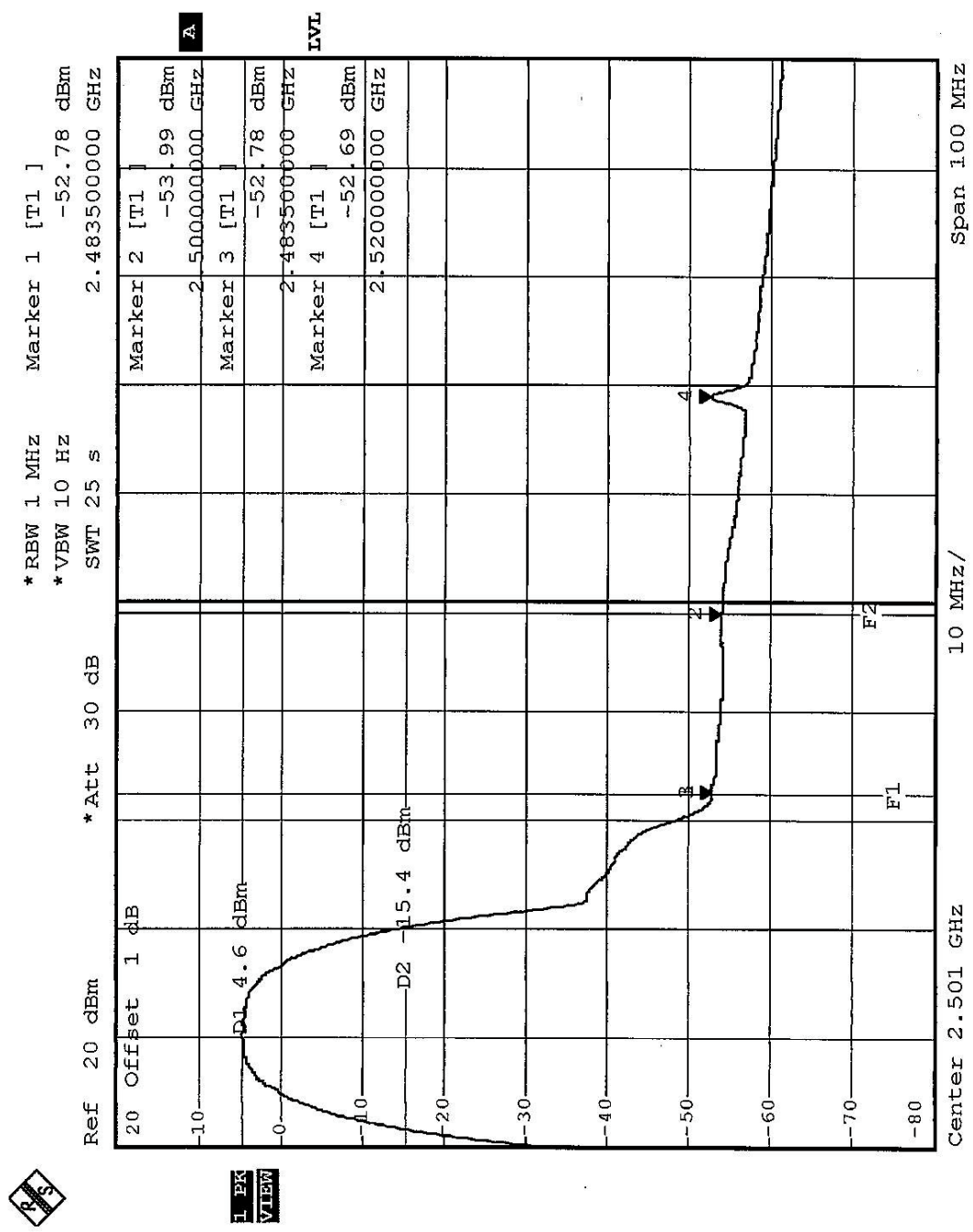

CH1

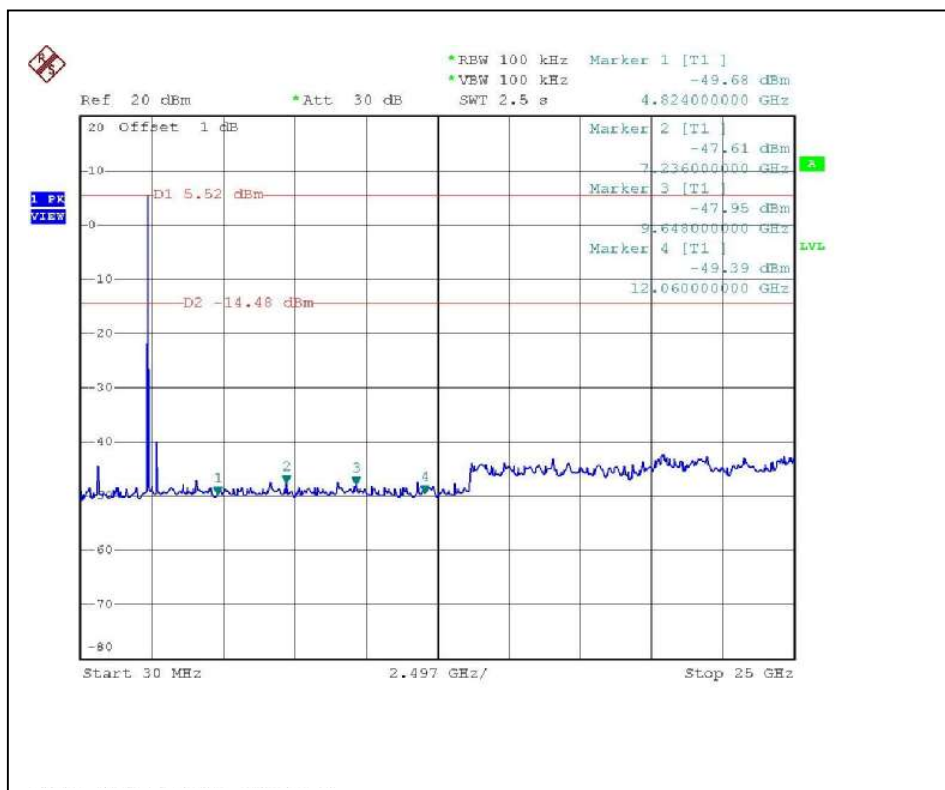

CH11

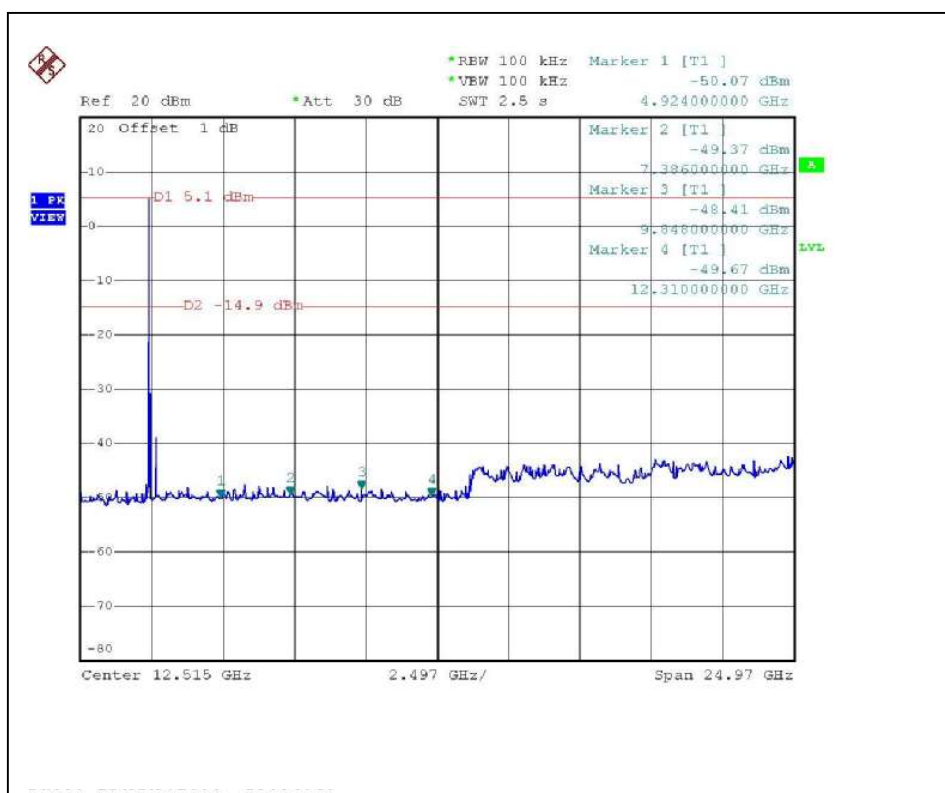

802.11g OFDM modulation

NOTE (Peak):

The band edge emission plot of OFDM technique on the following pages show 48.15dB delta between carrier maximum power and local maximum emission in restrict band (2.3900GHz). The emission of carrier strength list in the test result of channel 1 at the item 4.2 is 101.5dBuV/m, so the maximum field strength in restrict band is $101.5-48.15=53.35$ dBuV/m which is under 74 dBuV/m limit.

The band edge emission plot of OFDM technique on the following pages shows 48.10dB delta between carrier maximum power and local maximum emission in restrict band (2.4835GHz). The emission of carrier strength list in the test result of channel 11 at the item 4.2 is 101.20dBuV/m, so the maximum field strength in restrict band is $101.20-48.10=53.10$ dBuV/m which is under 74 dBuV/m limit.

NOTE (Average):

The band edge emission plot of OFDM technique on the following pages shows 48.06dB delta between carrier maximum power and local maximum emission in restrict band (2.3900GHz). The emission of carrier strength list in the test result of channel 1 at the item 4.2 is 93.40dBuV/m, so the maximum field strength in restrict band is $93.40-48.06=45.34$ dBuV/m which is under 54 dBuV/m limit.

The band edge emission plot of OFDM technique on the following pages shows 49.89dB delta between carrier maximum power and local maximum emission in restrict band (2.4835GHz). The emission of carrier strength list in the test result of channel 11 at the item 4.2 is 92.9dBuV/m, so the maximum field strength in restrict band is $92.9-49.89=43.01$ dBuV/m which is under 54 dBuV/m limit.

CH1

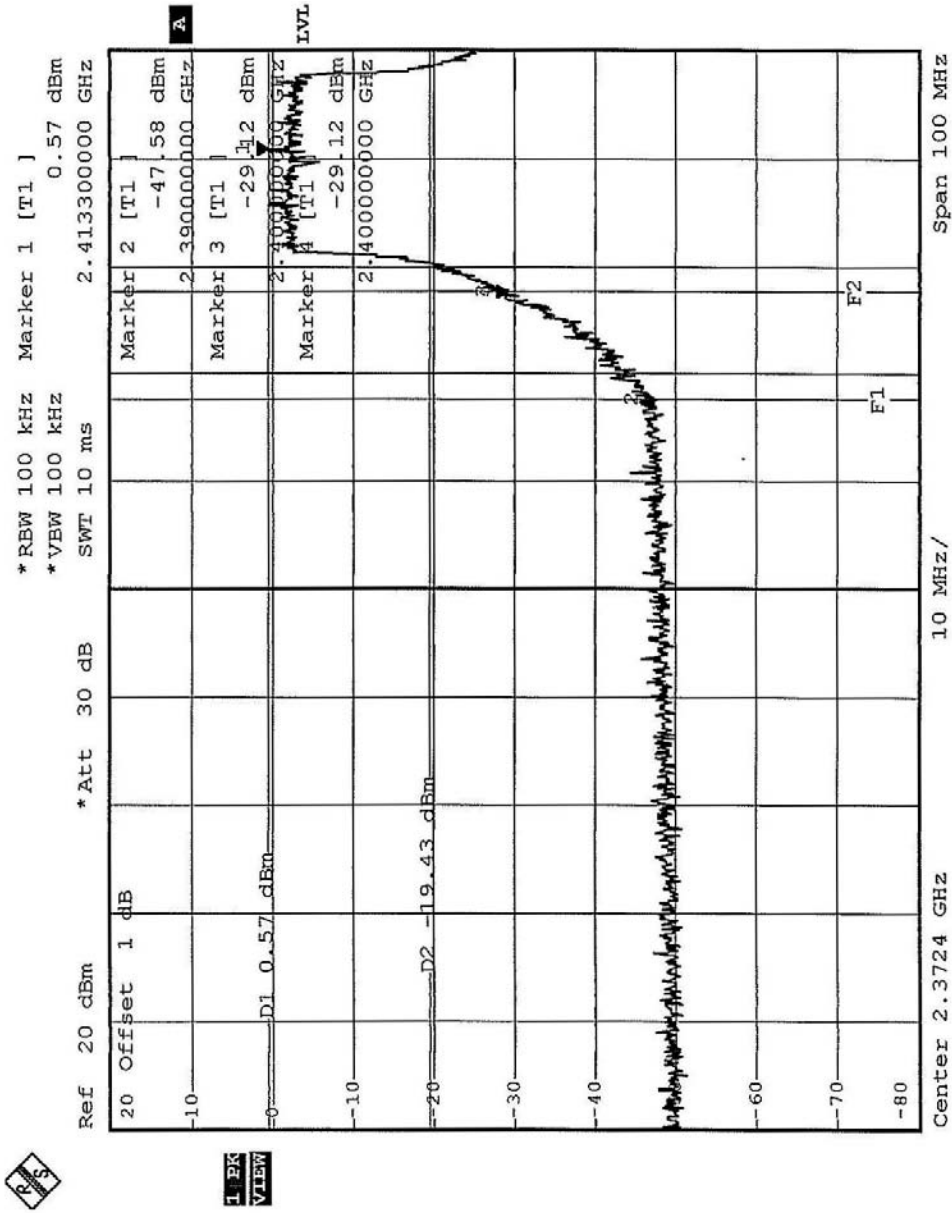

CH11

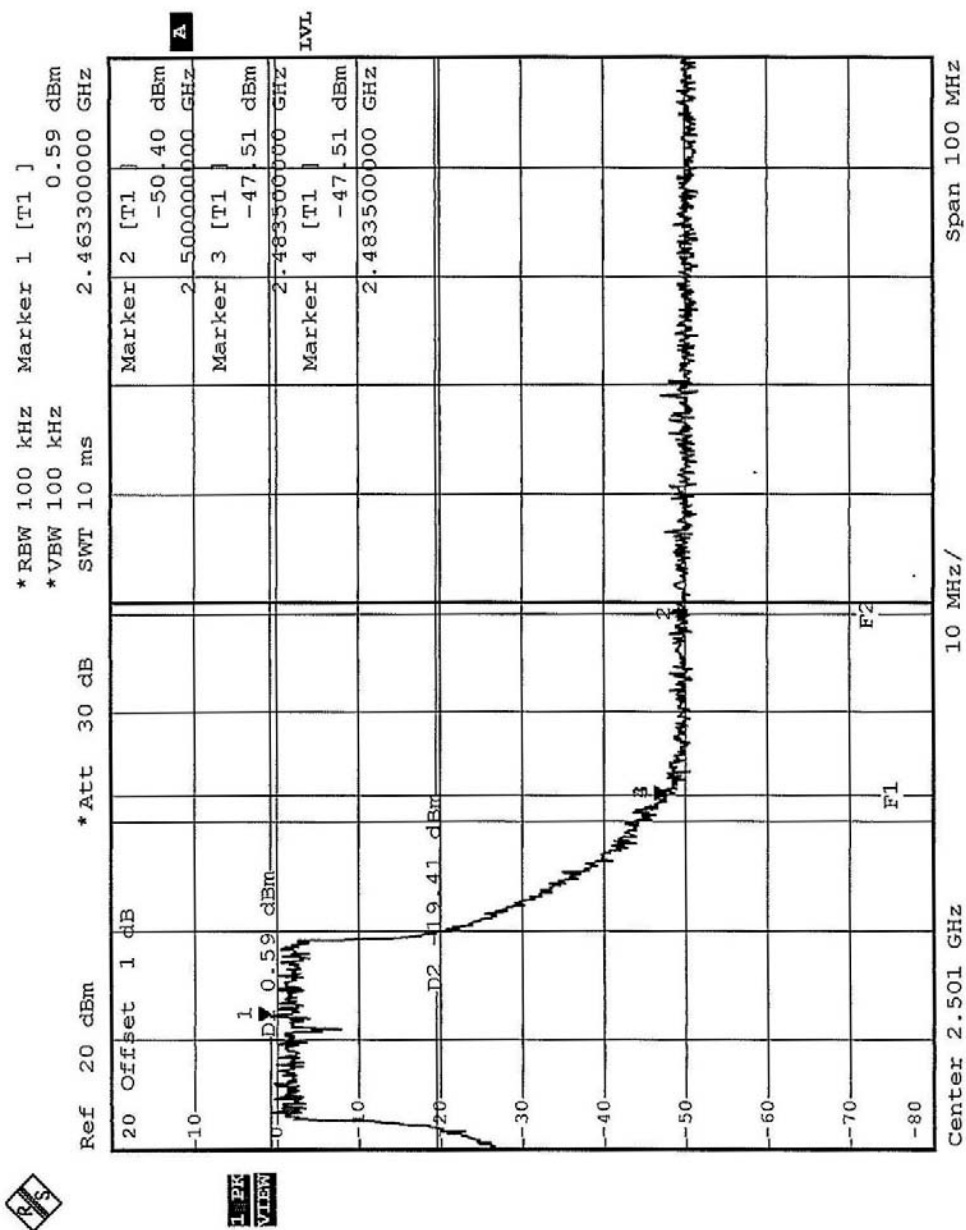

1 PK VIEW

CH1

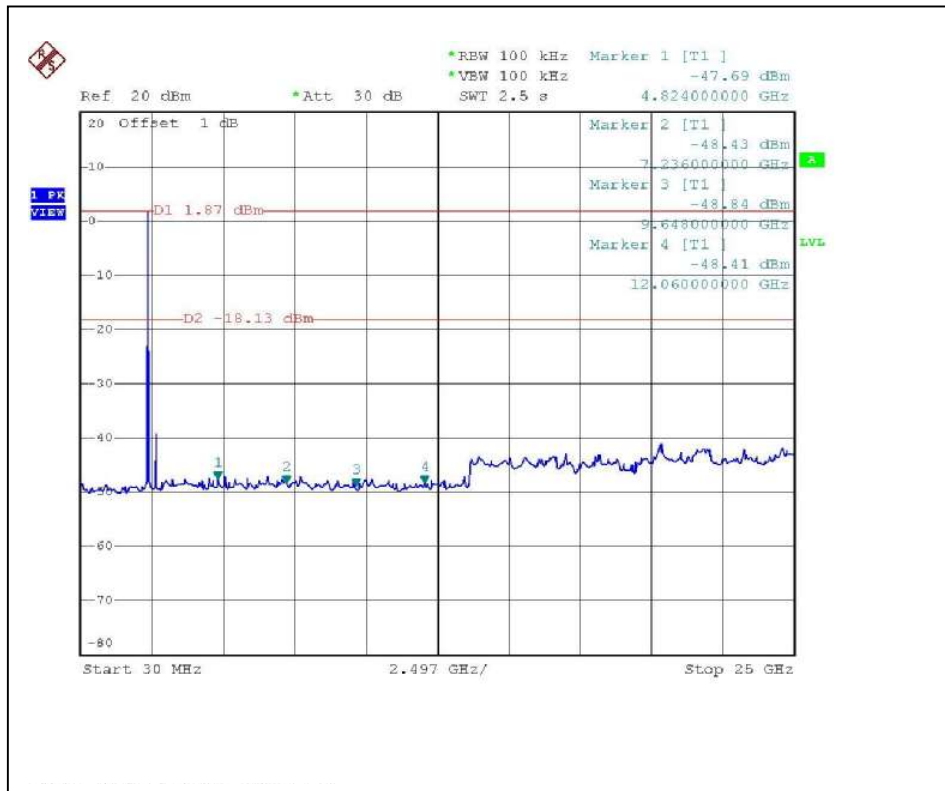

CH11

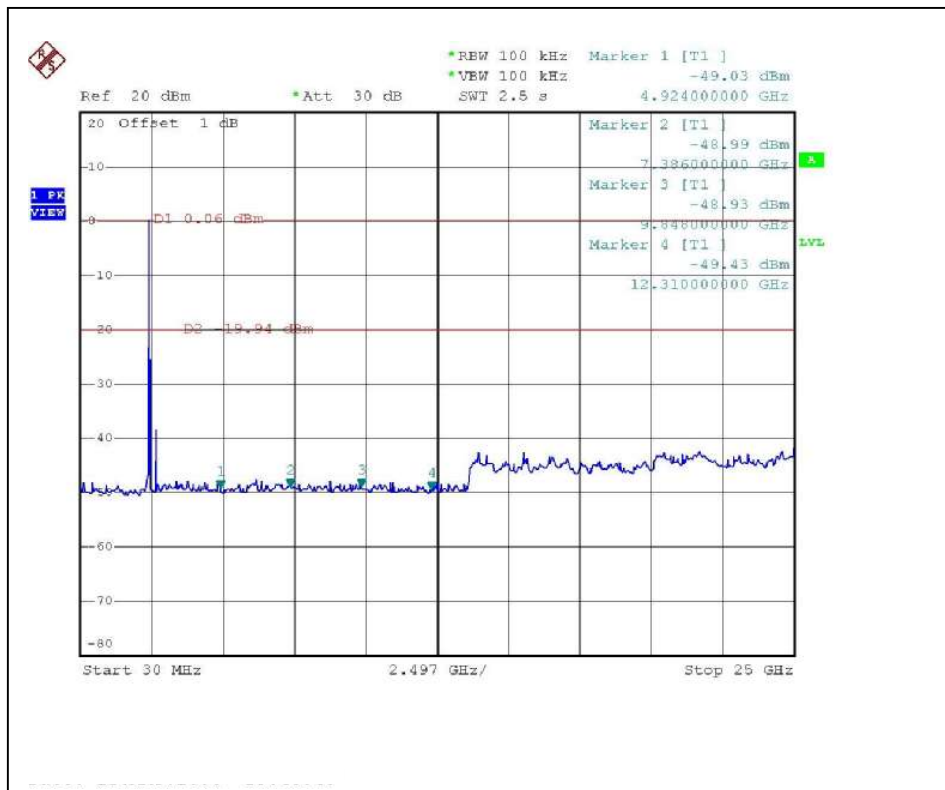

802.11g Turbo OFDM modulation

NOTE (Peak):

The band edge emission plot of OFDM technique on the following pages show 47.71dB delta between carrier maximum power and local maximum emission in restrict band (2.3900GHz). The emission of carrier strength list in the test result of channel 6 at the item 4.2 is 97.9dBuV/m, so the maximum field strength in restrict band is $97.9-47.71=50.19$ dBuV/m which is under 74 dBuV/m limit.

The band edge emission plot of OFDM technique on the following pages shows 49.54dB delta between carrier maximum power and local maximum emission in restrict band (2.4835GHz). The emission of carrier strength list in the test result of channel 6 at the item 4.2 is 97.9dBuV/m, so the maximum field strength in restrict band is $97.9-49.54=48.36$ dBuV/m which is under 74 dBuV/m limit.

NOTE (Average):

The band edge emission plot of OFDM technique on the following pages shows 49.16dB delta between carrier maximum power and local maximum emission in restrict band (2.3900GHz). The emission of carrier strength list in the test result of channel 6 at the item 4.2 is 89.6dBuV/m, so the maximum field strength in restrict band is $89.6-49.16=40.44$ dBuV/m which is under 54 dBuV/m limit.

The band edge emission plot of OFDM technique on the following pages shows 51.35dB delta between carrier maximum power and local maximum emission in restrict band (2.4835GHz). The emission of carrier strength list in the test result of channel 6 at the item 4.2 is 89.6dBuV/m, so the maximum field strength in restrict band is $89.6-51.35=38.25$ dBuV/m which is under 54 dBuV/m limit.

Turbo CH 6

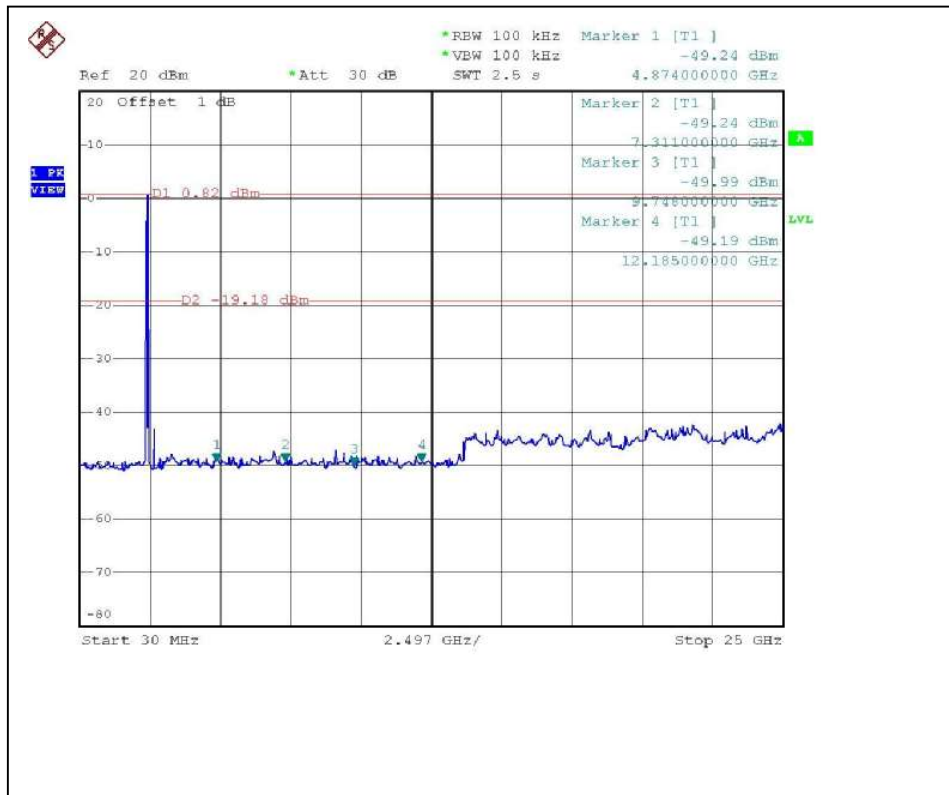

4.4 ANTENNA REQUIREMENT

4.4.1 STANDARD APPLICABLE

For intentional device, according to FCC 47 CFR Section 15.203, an intentional radiator shall be designed to ensure that no antenna other than that furnished by the responsible party shall be used with the device. And according to FCC 47 CFR Section 15.247 (b), if transmitting antennas of directional gain greater than 6dBi are used, the power shall be reduced by the amount in dB that the directional gain of the antenna exceeds 6dBi.

4.4.2 ANTENNA CONNECTED CONSTRUCTION

The antennas used in this product are as below:

No.	Gain (dBi)	Antenna Type	Antenna Connector
1	5.0	Dipole	RP-SMA
2	-2.0	Printed	NA

5. TEST TYPES AND RESULTS (802.11a, 5725~5850MHz Band)

5.1 RADIATED EMISSION MEASUREMENT

5.1.1 LIMITS OF RADIATED EMISSION MEASUREMENT

Emissions radiated outside of the specified bands, shall be according to the general radiated limits in 15.209 as following:

Frequencies (MHz)	Field strength (microvolts/meter)	Measurement distance (meters)
0.009-0.490	2400/F(kHz)	300
0.490-1.705	24000/F(kHz)	30
1.705-30.0	30	30
30-88	100	3
88-216	150	3
216-960	200	3
Above 960	500	3

NOTE:

1. The lower limit shall apply at the transition frequencies.
2. Emission level (dBuV/m) = 20 log Emission level (uV/m).
3. As shown in 15.35(b), for frequencies above 1000MHz, the field strength limits are based on average detector, however, the peak field strength of any emission shall not exceed the maximum permitted average limits, specified above by more than 20dB under any condition of modulation.



5.1.2 TEST INSTRUMENTS

DESCRIPTION & MANUFACTURER	MODEL NO.	SERIAL NO.	CALIBRATED UNTIL
ADVANTEST Spectrum Analyzer	R3271A	85060311	July 07, 2006
HP Pre_Amplifier	8449B	3008A01922	Oct. 02, 2006
ROHDE & SCHWARZ Test Receiver	ESCS30	100375	Sep. 19, 2006
CHASE Broadband Antenna	VULB9168	138	Dec. 11, 2006
Schwarzbeck Horn_Antenna	BBHA9120	D124	Dec. 27, 2006
Schwarzbeck Horn_Antenna	BBHA 9170	BBHA9170153	Jan. 05, 2007
SCHWARZBECK Biconical Antenna	VHBA9123	459	Jun. 26, 2006
SCHWARZBECK Periodic Antenna	UPA6108	1148	Jun. 26, 2006
RF Switches (ARNITSU)	CS-201	1565157	NA
RF CABLE (Chaintek)	SF102	22054-2	Nov. 16. 2006
RF Cable(RICHTEC)	9913-30M N-N Cable	STCCAB-30M- 1GHz	Jul. 16, 2006
Software	ADT_Radiated_V 5.14	NA	NA
CHANCE MOST Antenna Tower	AT-100	0203	NA
CHANCE MOST Turn Table	TT-100	0203	NA

Note: 1. The calibration interval of the above test instruments is 12 months (36 months for Periodic Antenna) and the calibrations are traceable to NML/ROC and NIST/USA.

2. The horn antenna and HP preamplifier (model: 8449B) are used only for the measurement of emission frequency above 1GHz if tested.
3. The test was performed in ADT Open Site No. C.
4. The FCC Site Registration No. is 656396.
5. The VCCI Site Registration No. is R-1626.
6. The CANADA Site Registration No. is IC 4824-3.
7. The following table is for the measurement uncertainty, which is calculated as per the document CISPR 16-4. This uncertainty represents an expanded uncertainty expressed at approximately the 95% confidence level using a coverage factor of k=2.

Measurement	Value
Radiated emissions (30MHz-1GHz)	2.98 dB
Radiated emissions (1GHz ~18GHz)	2.21 dB
Radiated emissions (18GHz ~40GHz)	1.88 dB

5.1.3 TEST PROCEDURES

- a. The EUT was placed on the top of a rotating table 0.8 meters above the ground at a 3 meter semi-anechoic chamber. The table was rotated 360 degrees to determine the position of the highest radiation.
- b. The EUT was set 3 meters away from the interference-receiving antenna, which was mounted on the top of a variable-height antenna tower.
- c. The antenna is a broadband antenna, and its height is varied from one meter to four meters above the ground to determine the maximum value of the field strength. Both horizontal and vertical polarizations of the antenna are set to make the measurement.
- d. For each suspected emission, the EUT was arranged to its worst case and then the antenna was tuned to heights from 1 meter to 4 meters and the rotatable table was turned from 0 degrees to 360 degrees to find the maximum reading.
- e. The test-receiver system was set to Peak Detect Function and Specified Bandwidth with Maximum Hold Mode.
- f. If the emission level of the EUT in peak mode was 10dB lower than the limit specified, then testing could be stopped and the peak values of the EUT would be reported. Otherwise the emissions that did not have 10dB margin would be re-tested one by one using peak, quasi-peak or average method as specified and then reported in a data sheet.

NOTE:

1. The resolution bandwidth and video bandwidth of test receiver/spectrum analyzer is 120kHz for Peak detection (PK) and Quasi-peak detection (QP) at frequency below 1GHz.
2. The resolution bandwidth and video bandwidth of test receiver/spectrum analyzer is 1 MHz for Peak detection at frequency above 1GHz.
3. The resolution bandwidth of test receiver/spectrum analyzer is 1 MHz and the video bandwidth is 10 Hz for Average detection (AV) at frequency above 1GHz.

5.1.4 DEVIATION FROM TEST STANDARD

No deviation

5.1.5 TEST SETUP

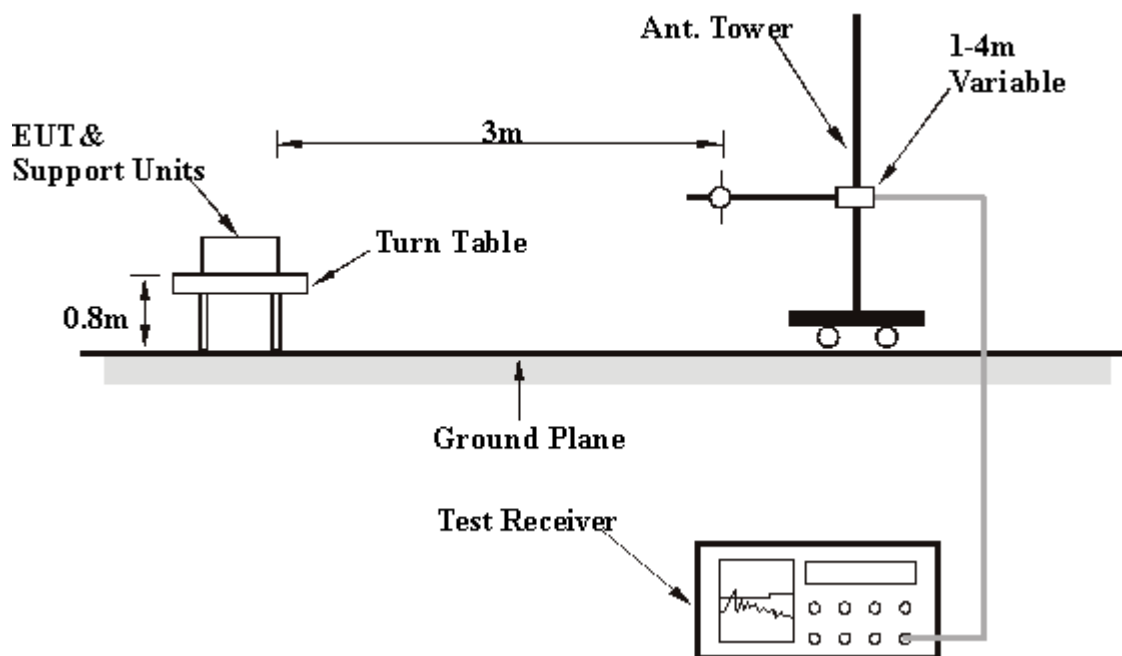

For the actual test configuration, please refer to the related item – Photographs of the Test Configuration.

5.1.6 EUT OPERATING CONDITIONS

Same as 4.1.6

5.1.7 TEST RESULTS

Below 1GHz Worst-Case Data

TEST MODE	With Adapter	FREQUENCY RANGE	30-1000 MHz
INPUT POWER (SYSTEM)	120Vac, 60Hz	DETECTOR FUNCTION & BANDWIDTH	Quasi-Peak, 120kHz
ENVIRONMENTAL CONDITIONS	27deg. C, 59%RH, 969 hPa	TESTED BY	Tony Chen

ANTENNA POLARITY & TEST DISTANCE: HORIZONTAL AT 3 M

No.	Freq. (MHz)	Emission Level (dBuV/m)	Limit (dBuV/m)	Margin (dB)	Antenna Height (m)	Table Angle (Degree)	Raw Value (dBuV)	Correction Factor (dB/m)
1	124.99	36.30 QP	43.50	-7.20	1.62 H	316	23.80	12.50
2	300.00	32.40 QP	46.00	-13.60	1.17 H	0	17.20	15.20
3	320.00	32.00 QP	46.00	-14.00	1.00 H	0	16.20	15.80
4	480.00	35.60 QP	46.00	-10.40	1.00 H	160	15.30	20.20
5	720.00	36.60 QP	46.00	-9.40	1.23 H	6	11.80	24.80
6	749.99	36.60 QP	46.00	-9.40	1.17 H	255	10.50	26.10
7	800.00	37.00 QP	46.00	-9.00	1.09 H	0	11.40	25.60
8	880.00	39.50 QP	46.00	-6.50	1.26 H	264	12.10	27.40
9	960.00	41.40 QP	46.00	-4.60	1.20 H	236	11.90	29.50

ANTENNA POLARITY & TEST DISTANCE: VERTICAL AT 3 M

No.	Freq. (MHz)	Emission Level (dBuV/m)	Limit (dBuV/m)	Margin (dB)	Antenna Height (m)	Table Angle (Degree)	Raw Value (dBuV)	Correction Factor (dB/m)
1	124.99	42.70 QP	43.50	-0.80	1.05 V	246	30.30	12.50
2	176.25	40.00 QP	43.50	-3.50	1.00 V	207	30.00	9.90
3	500.00	32.90 QP	46.00	-13.10	1.00 V	348	12.20	20.70
4	624.98	32.80 QP	46.00	-13.20	1.12 V	92	10.00	22.90
5	680.00	35.00 QP	46.00	-11.00	1.01 V	259	11.30	23.70
6	720.00	38.60 QP	46.00	-7.40	1.02 V	239	13.80	24.80
7	800.00	40.10 QP	46.00	-5.90	1.00 V	114	14.50	25.60
8	880.00	35.10 QP	46.00	-10.90	1.00 V	229	7.70	27.40
9	960.00	36.70 QP	46.00	-9.30	1.21 V	184	7.20	29.50

- REMARKS:**
1. Emission level(dBuV/m)=Raw Value(dBuV) + Correction Factor(dB)
 2. Correction Factor(dB/m) = Antenna Factor (dB/m) + Cable Factor (dB)
 3. The other emission levels were very low against the limit.
 4. Margin value = Emission level – Limit value.

TEST MODE	Adapter+POE	FREQUENCY RANGE	30-1000 MHz
INPUT POWER (SYSTEM)	120Vac, 60Hz	DETECTOR FUNCTION & BANDWIDTH	Quasi-Peak, 120kHz
ENVIRONMENTAL CONDITIONS	27deg. C, 59%RH, 969 hPa	TESTED BY	Tony Chen

ANTENNA POLARITY & TEST DISTANCE: HORIZONTAL AT 3 M

No.	Freq. (MHz)	Emission Level (dBuV/m)	Limit (dBuV/m)	Margin (dB)	Antenna Height (m)	Table Angle (Degree)	Raw Value (dBuV)	Correction Factor (dB/m)
1	124.99	40.90 QP	43.50	-2.60	2.62 H	339	28.40	12.50
2	174.99	32.90 QP	43.50	-10.60	2.37 H	0	22.90	10.10
3	320.00	34.70 QP	46.00	-11.30	1.00 H	359	18.90	15.80
4	439.99	40.10 QP	46.00	-5.90	1.00 H	262	20.80	19.30
5	749.98	34.30 QP	46.00	-11.70	1.17 H	267	8.20	26.10
6	760.00	39.60 QP	46.00	-6.40	1.08 H	37	13.60	26.00
7	800.00	32.50 QP	46.00	-13.50	1.11 H	23	6.90	25.60
8	839.99	34.00 QP	46.00	-12.00	1.00 H	30	7.10	26.90
9	879.99	43.30 QP	46.00	-2.70	1.00 H	4	16.00	27.40
10	919.99	34.60 QP	46.00	-11.40	1.00 H	5	6.30	28.30
11	959.99	35.70 QP	46.00	-10.30	1.00 H	348	6.30	29.50

ANTENNA POLARITY & TEST DISTANCE: VERTICAL AT 3 M

No.	Freq. (MHz)	Emission Level (dBuV/m)	Limit (dBuV/m)	Margin (dB)	Antenna Height (m)	Table Angle (Degree)	Raw Value (dBuV)	Correction Factor (dB/m)
1	79.99	34.10 QP	40.00	-5.90	1.00 V	95	26.10	8.00
2	124.99	42.40 QP	43.50	-1.10	2.42 V	22	29.90	12.50
3	175.00	40.90 QP	43.50	-2.60	1.00 V	68	30.80	10.10
4	249.99	30.20 QP	46.00	-15.80	1.00 V	171	16.20	14.00
5	500.04	34.80 QP	46.00	-11.20	1.00 V	68	14.10	20.70
6	550.00	30.80 QP	46.00	-15.20	1.24 V	103	8.00	22.80
7	624.98	31.30 QP	46.00	-14.70	1.00 V	233	8.40	22.90
8	749.98	34.00 QP	46.00	-12.00	1.00 V	181	7.90	26.10
9	759.99	38.70 QP	46.00	-7.30	1.44 V	3	12.60	26.00
10	839.99	32.30 QP	46.00	-13.70	1.70 V	223	5.40	26.90
11	879.99	33.70 QP	46.00	-12.30	1.26 V	22	6.30	27.40

- REMARKS:**
1. Emission level(dBuV/m)=Raw Value(dBuV) + Correction Factor(dB)
 2. Correction Factor(dB/m) = Antenna Factor (dB/m) + Cable Factor (dB)
 3. The other emission levels were very low against the limit.
 4. Margin value = Emission level – Limit value.

802.11a OFDM modulation

CHANNEL	Channel 1	FREQUENCY RANGE	1 ~ 40 GHz
MODULATION TYPE	BPSK	TRANSFER RATE	6Mbps
INPUT POWER (SYSTEM)	120Vac, 60 Hz	DETECTOR FUNCTION	Peak(PK) Average (AV)
ENVIRONMENTAL CONDITIONS	29deg. C, 61%RH, 969hPa	TESTED BY	Sky Liao

ANTENNA POLARITY & TEST DISTANCE: HORIZONTAL AT 3 M

No.	Freq. (MHz)	Emission Level (dBuV/m)	Limit (dBuV/m)	Margin (dB)	Antenna Height (m)	Table Angle (Degree)	Raw Value (dBuV)	Correction Factor (dB/m)
1	*5745.00	96.50 PK			1.62 H	59	59.10	37.40
1	*5745.00	87.00 AV			1.62 H	59	49.70	37.40
2	#11490.00	61.40 PK	74.00	-12.60	1.99 H	104	16.60	44.80
2	#11490.00	48.60 AV	54.00	-5.40	1.99 H	104	3.70	44.80
3	17235.00	64.30 PK	74.00	-9.70	1.67 H	165	12.60	51.70

ANTENNA POLARITY & TEST DISTANCE: VERTICAL AT 3 M

No.	Freq. (MHz)	Emission Level (dBuV/m)	Limit (dBuV/m)	Margin (dB)	Antenna Height (m)	Table Angle (Degree)	Raw Value (dBuV)	Correction Factor (dB/m)
1	*5745.00	108.30 PK			1.28 V	114	71.90	36.40
1	*5745.00	98.50 AV			1.28 V	114	62.10	36.40
2	#11490.00	64.30 PK	74.00	-9.70	1.50 V	244	13.20	51.10
2	#11490.00	52.30 AV	54.00	-1.70	1.50 V	244	1.20	51.10
3	17235.00	65.00 PK	74.00	-9.00	1.52 V	246	13.30	51.70

- NOTE:**
1. Emission level(dBuV/m)=Raw Value(dBuV) + Correction Factor(dB/m)
 2. Correction Factor(dB/m) = Antenna Factor (dB/m) + Cable Factor (dB)
 3. The other emission levels were very low against the limit.
 4. Margin value = Emission level – Limit value
 5. "*" : Fundamental frequency
 6. "#"The radiated frequency falling in the restricted band.
 7. The limit value is defined as per 15.247



CHANNEL	Channel 5	FREQUENCY RANGE	1 ~ 40 GHz
MODULATION TYPE	BPSK	TRANSFER RATE	6Mbps
INPUT POWER (SYSTEM)	120Vac, 60 Hz	DETECTOR FUNCTION	Peak(PK) Average (AV)
ENVIRONMENTAL CONDITIONS	29deg. C, 61%RH, 969hPa	TESTED BY	Sky Liao

ANTENNA POLARITY & TEST DISTANCE: HORIZONTAL AT 3 M

No.	Freq. (MHz)	Emission Level (dBuV/m)	Limit (dBuV/m)	Margin (dB)	Antenna Height (m)	Table Angle (Degree)	Raw Value (dBuV)	Correction Factor (dB/m)
1	*5825.00	96.50 PK			1.46 H	64	59.90	36.60
1	*5825.00	86.60 AV			1.46 H	64	50.00	36.60
2	#11650.00	60.20 PK	74.00	-13.80	1.76 H	52	9.60	50.60
2	#11650.00	47.80 AV	54.00	-6.20	1.76 H	52	-2.80	50.60
3	17475.00	66.50 PK	74.00	-7.50	1.59 H	82	14.00	52.50

ANTENNA POLARITY & TEST DISTANCE: VERTICAL AT 3 M

No.	Freq. (MHz)	Emission Level (dBuV/m)	Limit (dBuV/m)	Margin (dB)	Antenna Height (m)	Table Angle (Degree)	Raw Value (dBuV)	Correction Factor (dB/m)
1	*5825.00	107.80 PK			1.46 V	302	71.20	36.60
1	*5825.00	97.90 AV			1.46 V	302	61.30	36.60
2	#11650.00	64.70 PK	74.00	-9.30	1.32 V	242	14.10	50.60
2	#11650.00	51.70 AV	54.00	-2.30	1.32 V	242	1.10	50.60
3	17475.00	65.90 PK	74.00	-8.10	1.37 V	247	13.40	52.50

- NOTE:**
1. Emission level(dBuV/m)=Raw Value(dBuV) + Correction Factor(dB/m)
 2. Correction Factor(dB/m) = Antenna Factor (dB/m) + Cable Factor (dB)
 3. The other emission levels were very low against the limit.
 4. Margin value = Emission level – Limit value
 5. "*" : Fundamental frequency
 6. "#"The radiated frequency falling in the restricted band.
 7. The limit value is defined as per 15.247

802.11a Turbo OFDM modulation

CHANNEL	Channel 1	FREQUENCY RANGE	1 ~ 40 GHz
MODULATION TYPE	BPSK	TRANSFER RATE	12Mbps
INPUT POWER (SYSTEM)	120Vac, 60 Hz	DETECTOR FUNCTION	Peak(PK) Average (AV)
ENVIRONMENTAL CONDITIONS	29deg. C, 61%RH, 969hPa	TESTED BY	Sky Liao

ANTENNA POLARITY & TEST DISTANCE: HORIZONTAL AT 3 M

No.	Freq. (MHz)	Emission Level (dBuV/m)	Limit (dBuV/m)	Margin (dB)	Antenna Height (m)	Table Angle (Degree)	Raw Value (dBuV)	Correction Factor (dB/m)
1	*5760.00	92.60 PK			1.87 H	93	56.20	36.40
1	*5760.00	83.00 AV			1.87 H	93	46.60	36.40
2	#11520.00	61.10 PK	74.00	-12.90	1.43 H	115	10.00	51.10
2	#11520.00	48.40 AV	54.00	-5.60	1.43 H	115	-2.70	51.10
3	17280.00	66.10 PK	74.00	-7.90	1.43 H	115	13.90	52.20

ANTENNA POLARITY & TEST DISTANCE: VERTICAL AT 3 M

No.	Freq. (MHz)	Emission Level (dBuV/m)	Limit (dBuV/m)	Margin (dB)	Antenna Height (m)	Table Angle (Degree)	Raw Value (dBuV)	Correction Factor (dB/m)
1	*5760.00	105.80 PK			1.28 V	10	69.40	36.40
1	*5760.00	96.40 AV			1.28 V	10	60.00	36.40
2	#11520.00	63.40 PK	74.00	-10.60	1.28 V	249	12.30	51.10
2	#11520.00	50.30 AV	54.00	-3.70	1.28 V	249	-0.80	51.10
3	17280.00	65.50 PK	74.00	-8.50	1.46 V	219	13.30	52.20

- NOTE:**
1. Emission level(dBuV/m)=Raw Value(dBuV) + Correction Factor(dB/m)
 2. Correction Factor(dB/m) = Antenna Factor (dB/m) + Cable Factor (dB)
 3. The other emission levels were very low against the limit.
 4. Margin value = Emission level – Limit value
 5. "*" : Fundamental frequency
 6. "#":The radiated frequency falling in the restricted band.
 7. The limit value is defined as per 15.247



CHANNEL	Channel 2	FREQUENCY RANGE	1 ~ 40 GHz
MODULATION TYPE	BPSK	TRANSFER RATE	12Mbps
INPUT POWER (SYSTEM)	120Vac, 60 Hz	DETECTOR FUNCTION	Peak(PK) Average (AV)
ENVIRONMENTAL CONDITIONS	29deg. C, 61%RH, 969hPa	TESTED BY	Sky Liao

ANTENNA POLARITY & TEST DISTANCE: HORIZONTAL AT 3 M

No.	Freq. (MHz)	Emission Level (dBuV/m)	Limit (dBuV/m)	Margin (dB)	Antenna Height (m)	Table Angle (Degree)	Raw Value (dBuV)	Correction Factor (dB/m)
1	*5800.00	92.60 PK			1.46 H	65	56.10	36.60
1	*5800.00	83.50 AV			1.46 H	65	47.00	36.60
2	#11600.00	61.10 PK	74.00	-12.90	1.58 H	66	10.30	50.80
2	#11600.00	48.00 AV	54.00	-6.00	1.58 H	66	-2.90	50.80
3	17400.00	65.40 PK	74.00	-8.60	1.56 H	76	12.10	53.40

ANTENNA POLARITY & TEST DISTANCE: VERTICAL AT 3 M

No.	Freq. (MHz)	Emission Level (dBuV/m)	Limit (dBuV/m)	Margin (dB)	Antenna Height (m)	Table Angle (Degree)	Raw Value (dBuV)	Correction Factor (dB/m)
1	*5800.00	105.60 PK			1.39 V	9	69.00	36.60
1	*5800.00	96.20 AV			1.39 V	9	59.60	36.60
2	11600.00	62.10 PK	74.00	-11.90	1.38 V	240	11.30	50.80
2	11600.00	50.30 AV	54.00	-3.70	1.38 V	240	-0.50	50.80
3	17400.00	66.10 PK	74.00	-7.90	1.29 V	121	12.70	53.40

- NOTE:**
1. Emission level(dBuV/m)=Raw Value(dBuV) + Correction Factor(dB/m)
 2. Correction Factor(dB/m) = Antenna Factor (dB/m) + Cable Factor (dB)
 3. The other emission levels were very low against the limit.
 4. Margin value = Emission level – Limit value
 5. "*" : Fundamental frequency
 6. "#"The radiated frequency falling in the restricted band.
 7. The limit value is defined as per 15.247



5.2 MAXIMUM PEAK OUTPUT POWER

5.2.1 LIMITS OF MAXIMUM PEAK OUTPUT POWER MEASUREMENT

The Maximum Peak Output Power Measurement is 30dBm.

5.2.2 INSTRUMENTS

Description & Manufacturer	Model No.	Serial No.	Calibrated Until
R&S SPECTRUM ANALYZER	FSP40	100036	Nov. 23, 2006

NOTE:

- 1.The measurement uncertainty is less than +/- 2.6dB, which is calculated as per the NAMAS document NIS81. This uncertainty represents an expanded uncertainty expressed at approximately the 95% confidence level using a coverage factor of k=2.
- 2.The calibration interval of the above test instruments is 12 months and the calibrations are traceable to NML/ROC and NIST/USA.

5.2.3 TEST PROCEDURES

1. A detector was used on the output port of the EUT. An oscilloscope was used to read the response of the detector.
2. Replaced the EUT by the signal generator . The center frequency of the S.G was adjusted to the center frequency of the measured channel.
3. Adjusted the power to have the same reading on oscilloscope. Record the power level.

5.2.4 DEVIATION FROM TEST STANDARD

No deviation

5.2.5 TEST SETUP



5.2.6 EUT OPERATING CONDITIONS

Same as Item 4.1.6

5.2.7 TEST RESULTS

802.11a OFDM modulation

MODULATION TYPE	BPSK	TRANSFER RATE	6Mbps
INPUT POWER (SYSTEM)	120Vac, 60 Hz	ENVIRONMENTAL CONDITIONS	30deg. C, 65%RH, 991 hPa
TESTED BY	Sky Liao		

CHANNEL	CHANNEL FREQUENCY (MHz)	PEAK POWER OUTPUT (mW)	PEAK POWER OUTPUT (dBm)	PEAK POWER LIMIT (dBm)	PASS/FAIL
1	5745	28.840	14.60	30	PASS
5	5825	28.840	14.60	30	PASS

802.11a Turbo OFDM modulation

MODULATION TYPE	BPSK	TRANSFER RATE	12Mbps
INPUT POWER (SYSTEM)	120Vac, 60 Hz	ENVIRONMENTAL CONDITIONS	30deg. C, 65%RH, 991 hPa
TESTED BY	Sky Liao		

CHANNEL	CHANNEL FREQUENCY (MHz)	PEAK POWER OUTPUT (mW)	PEAK POWER OUTPUT (dBm)	PEAK POWER LIMIT (dBm)	PASS/FAIL
1	5760	25.119	14.00	30	PASS
2	5800	27.542	14.40	30	PASS

5.3 BAND EDGES MEASUREMENT

5.3.1 LIMITS OF BAND EDGES MEASUREMENT

Below -20dB of the highest emission level of operating band (in 1MHz Resolution Bandwidth).

5.3.2 TEST INSTRUMENTS

Description & Manufacturer	Model No.	Serial No.	Calibrated Until
R&S SPECTRUM ANALYZER	FSP40	100036	Nov. 23, 2006

NOTE:

- 1.The measurement uncertainty is less than $\pm 2.6\text{dB}$, which is calculated as per the NAMAS document NIS81. This uncertainty represents an expanded uncertainty expressed at approximately the 95% confidence level using a coverage factor of $k=2$.
- 2.The calibration interval of the above test instruments is 12 months and the calibrations are traceable to NML/ROC and NIST/USA.

5.3.3 TEST PROCEDURE

The transmitter output was connected to the spectrum analyzer via a low lose cable. Set RBW spectrum analyzer to 1 MHz and set VBW spectrum analyzer to 10 Hz with suitable frequency span including 100 MHz bandwidth from band edge. The band edges was measured and recorded.

The spectrum plots (Peak RBW=VBW=100kHz) are attached on the following pages.

5.3.4 DEVIATION FROM TEST STANDARD

No deviation

5.3.5 EUT OPERATING CONDITION

Same as Item 4.1.6

5.3.6 TEST RESULTS

The spectrum plots are attached on the following pages. D2 line indicates the highest level, D1 line indicates the 20dB offset below D2. It shows compliance with the requirement in part 15.247(d).

802.11a OFDM modulation

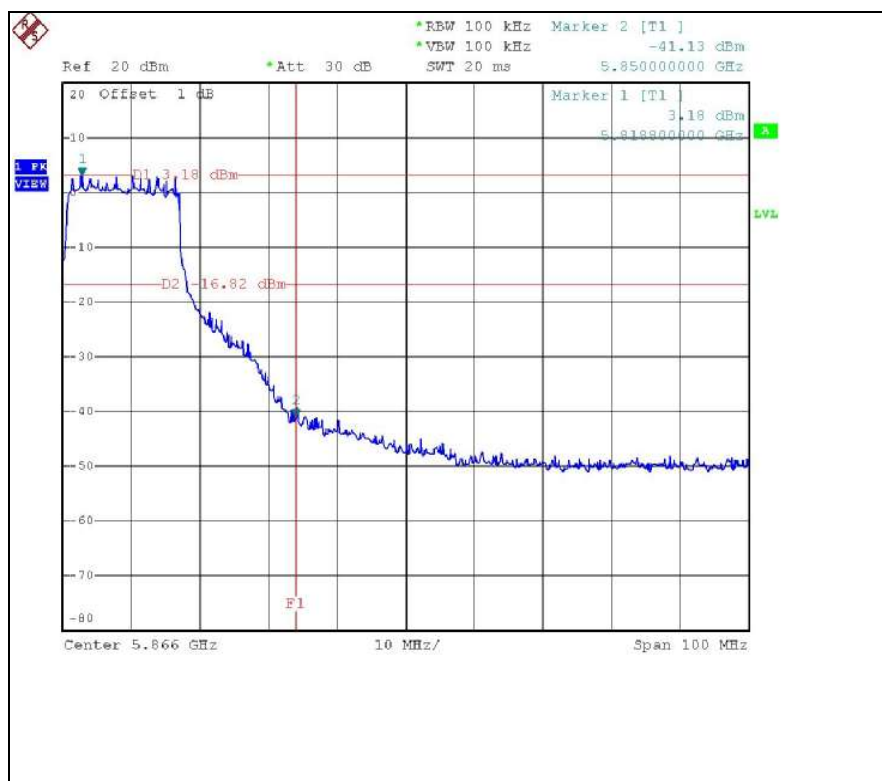
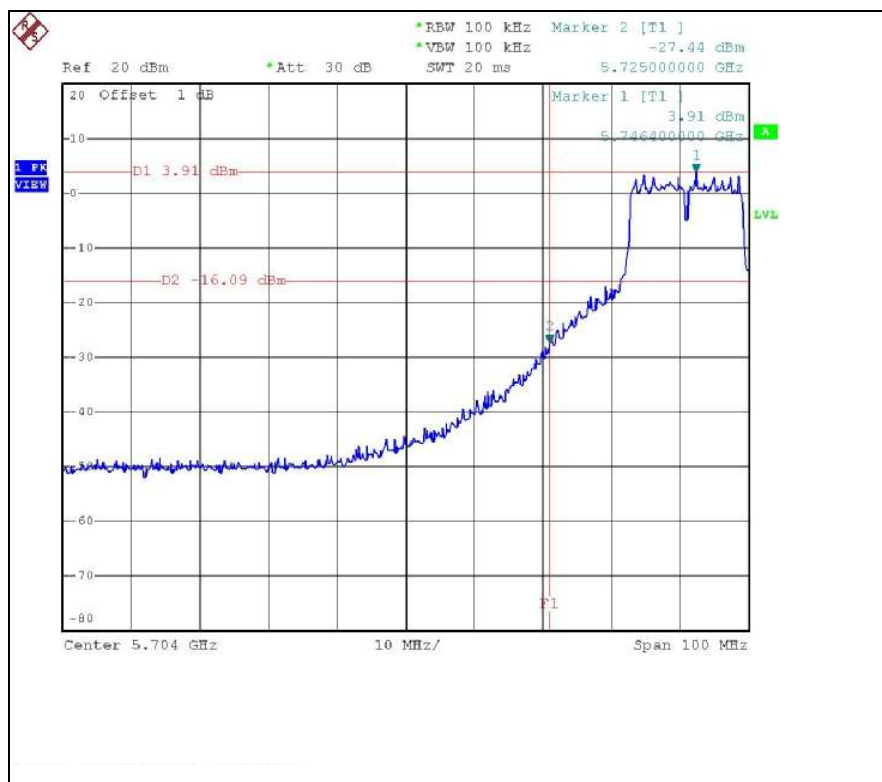

CH 1

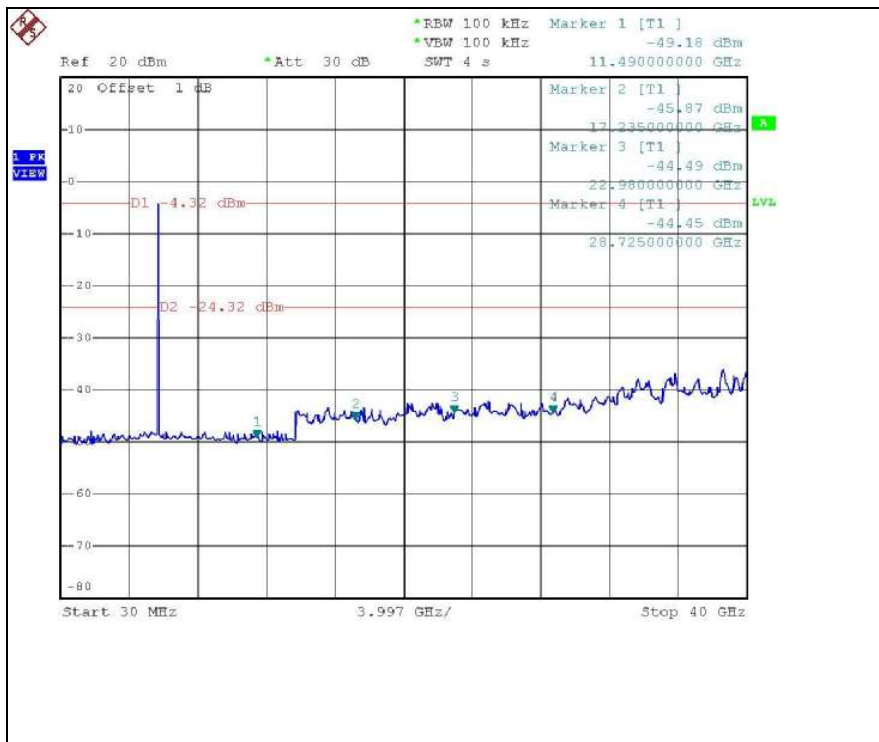

CH 5

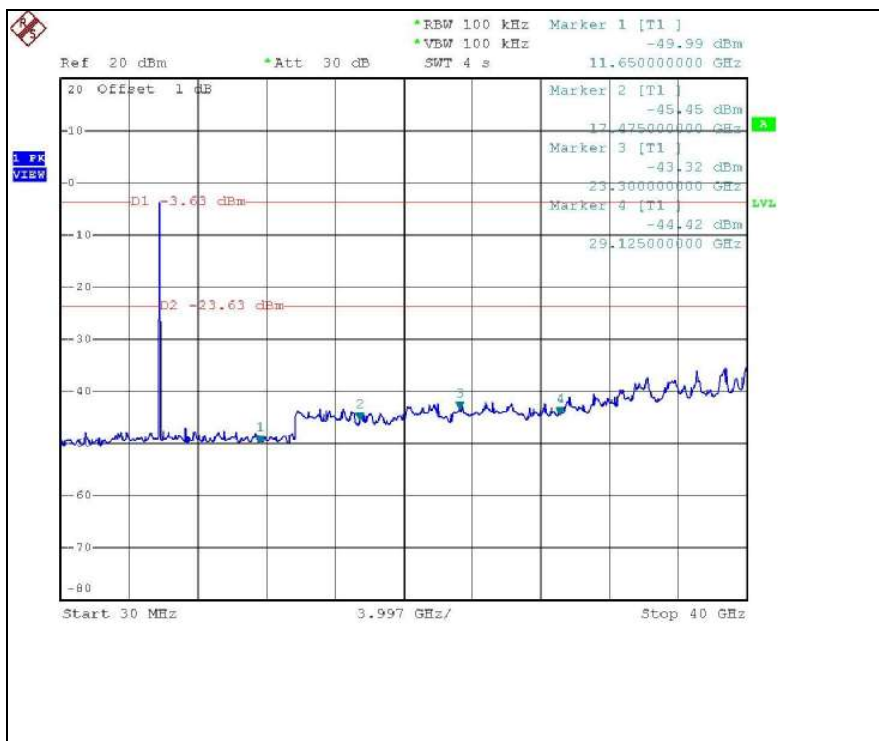

CH 1

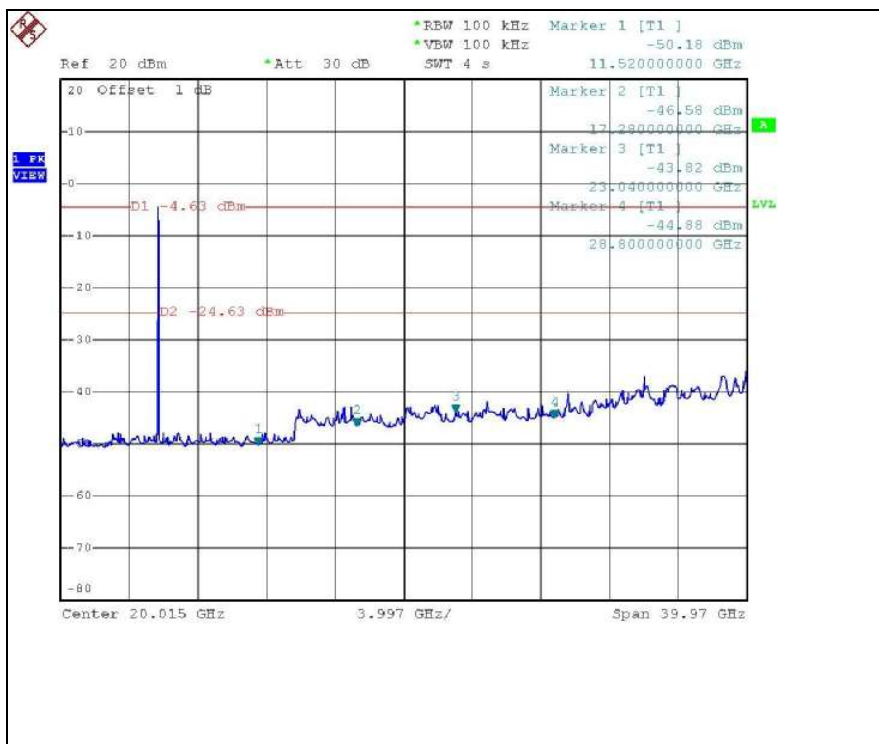

CH 2

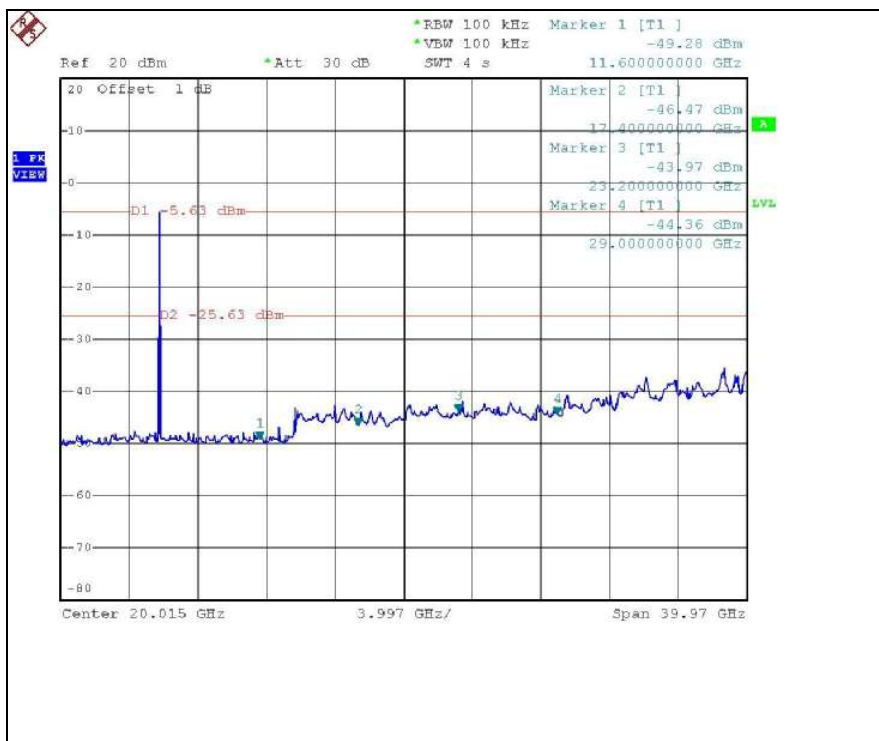

5.4 ANTENNA REQUIREMENT

5.4.1 STANDARD APPLICABLE

For intentional device, according to FCC 47 CFR Section 15.203, an intentional radiator shall be designed to ensure that no antenna other than that furnished by the responsible party shall be used with the device.

And according to FCC 47 CFR Section 15.247(a), if transmitting antennas of directional gain greater than 6dBi are used, the power shall be reduced by the amount in dB that the directional gain of the antenna exceeds 6dBi.

5.4.2 ANTENNA CONNECTED CONSTRUCTION

The antennas used in this product are as below:

No.	Gain (dBi)	Antenna Type	Antenna Connector
1	5.0	Dipole	RP-SMA
2	-1.07(for 5.15-5.35GHz) 3.02(for 5.725-5.85GHz)	Printed	NA

6. PHOTOGRAPHS OF THE TEST CONFIGURATION

CONDUCTED EMISSION TEST (With Adapter)



(With Adapter+POE)



RADIATED EMISSION TEST (With Adapter)



(With Adapter +POE)

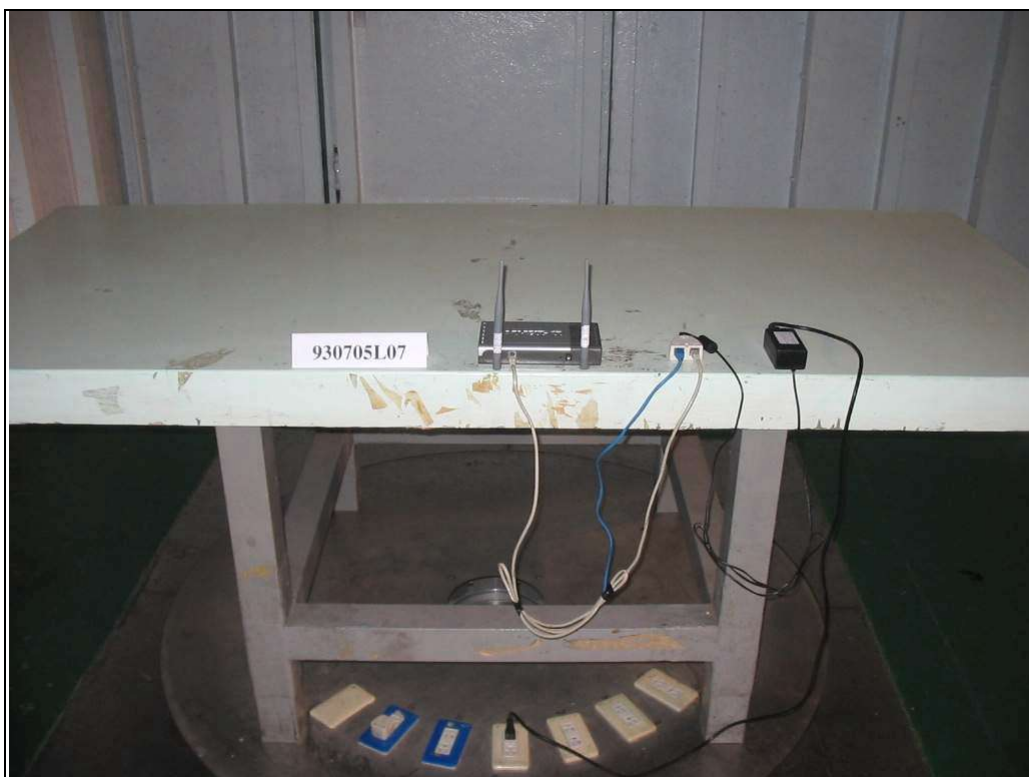



7. INFORMATION ON THE TESTING LABORATORIES

We, ADT Corp., were founded in 1988 to provide our best service in EMC, Radio, Telecom and Safety consultation. Our laboratories are accredited and approved by the following approval agencies according to ISO/IEC 17025:

USA	FCC, UL, A2LA
Germany	TUV Rheinland
Japan	VCCI
Norway	NEMKO
Canada	INDUSTRY CANADA, CSA
R.O.C.	CNLA, BSMI, DGT
Netherlands	Telefication
Singapore	PSB, GOST-ASIA (MOU)
Russia	CERTIS (MOU)

Copies of accreditation certificates of our laboratories obtained from approval agencies can be downloaded from our web site: www.adt.com.tw/index.5/phtml.

If you have any comments, please feel free to contact us at the following:

Linko EMC/RF Lab:

Tel: 886-2-26052180

Fax: 886-2-26052943

Hsin Chu EMC/RF Lab:

Tel: 886-3-5935343

Fax: 886-3-5935342

Hwa Ya EMC/RF/Safety/Telecom Lab:

Tel: 886-3-3183232

Fax: 886-3-3185050

Email: service@adt.com.tw

Web Site: www.adt.com.tw

The address and road map of all our labs can be found in our web site also.



APPENDIX-A

MODIFICATIONS RECORDERS FOR ENGINEERING CHANGES TO THE EUT BY THE LAB

No any modifications are made to the EUT by the lab during the test.