

**MANUAL FOR INSTALLATION
AND OPERATING INSTRUCTION**

SJ10M2

USER MANUAL

FCC REQUIREMENT

**This device complies with Part 15 of FCC Rules.
Operation is subject to the following two
conditions : (1) this device may not cause
harmful interference, and (2) this device must
accept any interference received, including
interference that may cause undesired operation.**

**CAUTION : Any change or modification in construction
of this device which are not expressly approved by the
party responsible for compliance could void the user's
authority to operate the equipment**

INTRODUCTION ...

Thank you for choosing K3M SECURITY for your automotive security needs. K3M is committed to enhancing the security of your automobile by creating State-Of-The-Art automotive security devices. Our products are the result of many years of testing and product evaluations. This translates to a quality product you can depend on for years to come.

It is very important you take the time to learn the particulars of the SJ10M2. Even though many auto security devices seem to operate the same, there is definite difference between products and their operation. Learning the features, operations and options of this security system will ensure you have been afforded the maximum in security and convenience.

If you have any questions, please don't hesitate to contact your K3M dealer, or our main office. All of our numbers are listed in the back of this User Manual. K3M SECURITY has always had an "Open Ear" policy with our customers and dealers. Any suggestion, or comment you may have concerning our products is greatly appreciated.

In the unlikely event you need help from K3M SECURITY, we would like to give you some contact number that will access the correct departments to handle your needs and suggestions.

TABLE OF CONTENTS

FEATURES

COMPONENTS

OPERATION

TROUBLESHOOTING

CONTACT US

FEATURES

- **Two Key-Chain Remote Transmitters**
- **Computerized Microprocessor Electronics**
- **Six-Tone Electronic Siren**
- **Two-Stage Electronic Impact Sensor**
- **On-Board Door Lock Relays**
- **On-Board Park Light Flash Relay**
- **On-Board Channel (2) Relay**
- **On-Board Dome Light Relay**
- **On-Board Impact Sensor**
- **Pre-Wired Valet Switch**
- **Pre-Wired Impact Sensor**
- **Pre-Wired Super Bright LED**
- **Starter Disable Output**
- **Zoned Inputs**
- **Channel (3) Negative Output**
- **Ground When Armed Output**
- **Positive/Negative Siren Control**
- **Permanent Chirp Defeat**

- One-Time Chirp Defeat
- Passive / Active Arming
- Passive Door Locking
- Ignition Door / Unlock
- Car Finder
- Anti-Car Jacking
- Completely Plug-In
- Alarm Memory

THE COMPONENTS

Your SJ10M2 Security System was shipped with the following components. We will explain each of the components to you and their use. Your K3M Security System may be capable of operations that require additional labor, not usually quoted in a "basic" installation. Please check with your installing dealer to determine what is a "standard" installation and what is a "customized" installation.

REMOTE CONTROL TRANSMITTERS

Your SJ10M2 Security System is shipped with TWO Key-Chain Transmitters electronically coded to the Main Control Box. There are two buttons on the face of the transmitters that command the operations of the SJ10M2 Security System. The buttons operate as follows:

BUTTON #1 (Top Button) = Arms and Disarms the SJ10M2.

BUTTON #2 (Bottom Button) = Opens the trunk (option) / or silently "arms" and "disarms" the SJ10M2 if depressed BEFORE Button #1.

(Example: Depress Button #2, then Button #1. The SJ10M2 will "Arm" or Disarm" without chirping the siren)

BUTTONS #1+#2 (Together) = Commands a Channel (3) Signal. This signal is generally used to command a Remote Starter Module, but can be used to operate any vehicle function.

Button	Duration	Result
1	Short	Arm/Disarm
1	Long	Panic Siren
2	Short	Chirp Delete
2	Long	Trunk Open
1+2, or 3	Long	Car Finder
1+2, or 3(IGN)	Long	Car-Jacking(Optional)

CHANGING TRANSMITTER BATTERIES

To change the batteries in your K3M Remote Control Transmitter (Should be done every 6 months) follow the instructions below. Contrary to popular belief, the red light on the transmitter is no indication the battery is good. The red light is there for a visual confirmation

the buttons in the transmitter are functional. Battery current is most important for range. Let the decreased transmission range inform you the batteries are wearing out.

TWO BUTTON TRANSMITTER

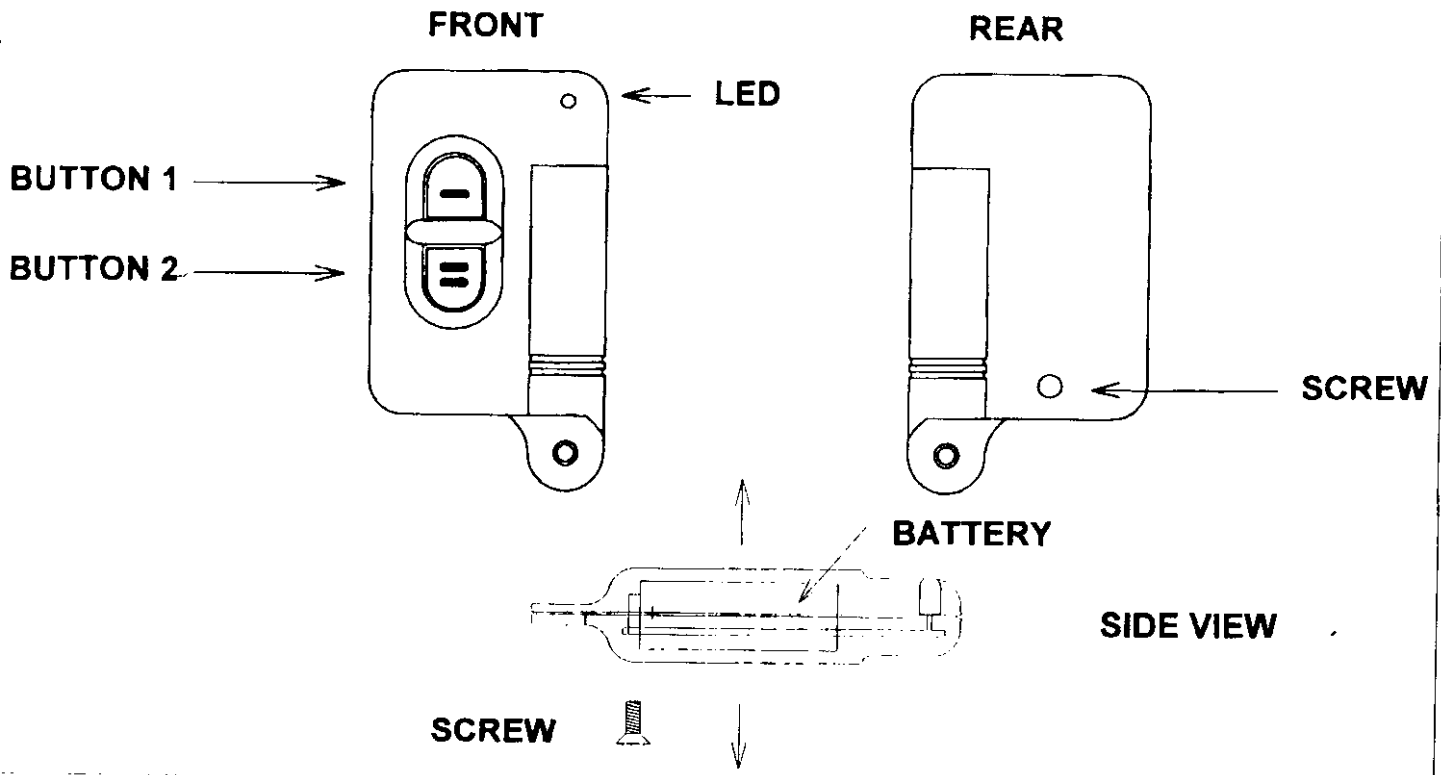

THREE BUTTON TRANSMITTER

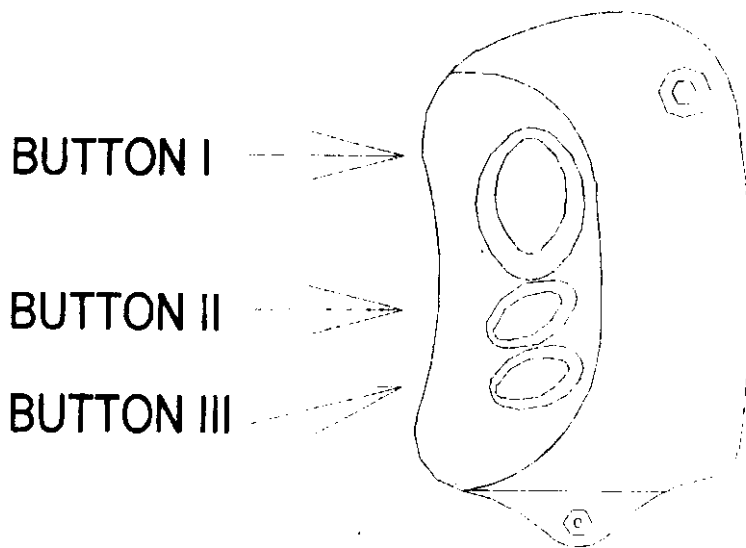

- 1) Remove the containment screw located on the bottom of the transmitter case.
- 2) GENTLY .. split the case open with a butter knife or small screw driver.
- 3) Notice the battery position. There are (-) & (+) marks embedded in the plastic case where the battery sits.

- 4) Change the battery with respect to the proper battery position.
- 5) Reassemble the case and tighten the case screw until it's SNUG.
- 6) Test the remote.

THE MAIN CONTROL BOX (CPU)

The SJ10M2 is controlled by a State-Of-The-Art master control unit. The "Main Brain" as referred to by installers is designed to be installed within the interior of your vehicle. The suggested mounting location is under the dash of your vehicle. It is important the CPU not be mounted in a location subject to adverse weather conditions.

Not only do ALL functions of the SJ10M2 originate from this Main Control Box, it also holds the two power fuses that supply power to the electronics and the Parking Light Flash circuits. It might be a good idea to know where the control box is located in case a fuse needs to be changed by an installer that did not do the original installation.

LED ARMED STATUS INDICATOR

The LED (Small red light) is your visual confirmation the SJ10M2 is Armed, Off or in Valet Mode. The LED also doubles as a troubleshooter by telling you what zone made your alarm sound off. (Alarm Memory)

When Armed, this Super-Bright LED flashes to a steady beat to confirm to you the system is actually Armed and works as a great visual deterrent to on-looking thieves.

When in Valet Mode, this indicator illuminate with a solid red signal to inform you of this non-security mode.

After a violation, the LED indicator reports the intrusion zone by flashing a certain sequence to educate you what caused the alarm condition.

THE SIX-TONE ELECTRONIC SIREN

The SJ10M2 comes standard with a Six-Tone Electronic Siren. This siren emits a sound pressure of approximately 120 decibels. The open-air noise level would change from vehicle to vehicle with consideration to the difference in engine compartments and vehicle options.

The Electronic Siren is designed to withstand the undesirable conditions that exist in engine compartments. Moisture and heat will generally not effect the operation of this unit.

SJ10M2 OPERATION

HOW TO "ARM" and "DISARM" THE SJ10M2

- 1) Close all doors, hood and trunk.
- 2) Depress Button #1 (Top Button) on the Keychain Transmitter.
(You should hear the siren chirp and light will flash unless the chirps have been silenced by the transmitter or installer)
- 3) Wait approximately (5) seconds ... then open the door.
(The alarm should sound at full volume)

- 1) Turn "On" the vehicle's ignition system.
- 2) Flip "On" the Valet Switch. (Ask your installer where it is)
- 3) The LED Armed Status Indicator will turn on solid
- 4) Turn "Off" the ignition. The LED will also go out.

To bring the SJ10M2 out of Valet Mode:

- 1) Turn "On" the vehicle's ignition system.
- 2) Flip the Valet Switch to the "Off" position.
- 3) Turn "Off" the ignition key.

OPEN YOUR TRUNK (option)

If you have selected this option, your trunk can be opened by simply depressing Button #2 on your Keychain Transmitter and holding it for a couple of seconds. It's that easy!

If you have no electric trunk release, or have not selected to use this option, the Channel (2) relay contacts can be used to operate anything electrical on your vehicle .. just ask you installer.

NOTE: If you invoke the trunk release feature while the SJ10M2 is armed, you WILL sound the alarm! The SJ10M2 does not know the difference between the remote opening the trunk and a burglar. Disarm the SJ10M2 PRIOR to opening the trunk.

REMOTE START

To invoke a Remote Start signal to command an optional Remote Start Module, simply depress Buttons #1 + #2 at the same time (car off). This action will cause the SJ10M2 to output the proper electrical signal to command aftermarket Remote Starters.

Aftermarket Remote Starter Modules (such as the K3M H-S10) will take command of the Ignition and Impact detecting circuits and start your vehicle. This is a VERY handy feature to have if you live in HOT or COLD areas. Just enjoy your morning coffee while your vehicle warms up or cools off. What a life!

BASIC TROUBLESHOOTING

Even though we DON'T condone customers making their own repairs, we feel it necessary to enlighten you on several basic troubleshooting points that may save you an unnecessary drive back to the installing dealer for a simple problem.

Any major adjustments, wiring corrections, or option additions should be done by a qualified K3M dealer. When working with microprocessor computer equipment, a mistake as small as the wrong test light can permanently damage the Main Control Box.

The Doors Lock and Unlock, but the alarm will not Arm and Disarm with the Remote?

Check your Valet Switch and LED Armed Status Indicator light. If the Valet Switch has been placed in the "On" position while the Ignition Switch is "On," the SJ10M2 will enter the Valet Mode. The LED on solid should be your first indicator of this. Exit the Valet Mode.

Every Time I Arm my alarm, it chirps twice?

The SJ10M2 has a bad trigger notification system. If the input circuits detect a shorted door switch, they report the trouble. On vehicles with delay-out interior lights, the input line "looks" just like a door is open if the light is on. There is no way to stop this.

The defeated door input trigger will automatically be available to the system once the "trouble" goes away. Once the interior lights go out, the door will then sound the alarm if opened.

You sent me a new transmitter, but it doesn't operate the SJ10M2?

The new transmitter needs to be coded to the Main Control Box. This procedure is pretty simple. Follow these steps:

- 1) Turn "On" the Ignition Key.
- 2) Flip the Valet Switch "On" and "Off" (10) times in a row.
(This will cause the siren to sound)
- 3) Depress Button #1 (Top Button) on your Remote Transmitter.
(This will code the new Remote Control and silence the siren)
- 4) Immediately depress Button #1 on the other transmitter.
(Both codes will be remembered. Two codes maximum)

My system seems to False Alarm quite often, and nobody is anywhere near my car. What gives?

The Electronic Impact Sensor supplied with your K3M Security System is a very sensitive piece of equipment. A properly adjusted impact sensor will require a pretty good smack to cause a pre-alarm warning. It would require a VERY large impact to cause a full alarm condition. If your SJ10M2 is so sensitive that you can lightly hit the windows and get a response, you WILL experience false alarms! Turn it down... you neighbors may do more damage trying to silence your alarm than the thief ever did.

How can I get more range from my transmitter. I want to operate the alarm from inside the house.

You can get more range by ordering the optional "Long Range" antenna from K3M Security. The Extended Range antenna puts nothing between your transmitter and antenna system but glass. This can drastically increase the amount of range you will achieve.

INSATLL DIAGRAM

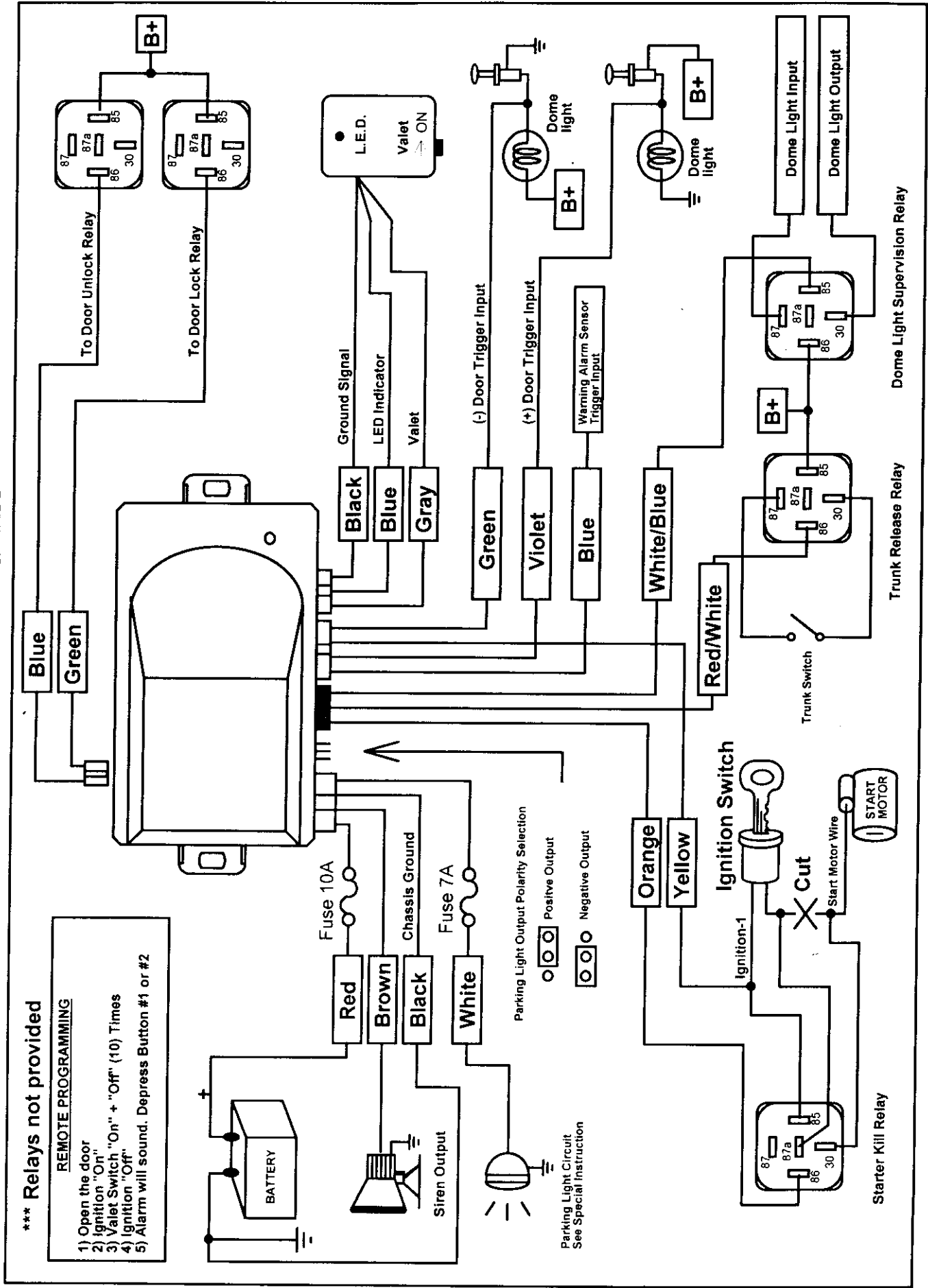

*** Relays not provided

REMOTE PROGRAMMING

- 1) Open the door
- 2) Ignition "On"
- 3) Valet Switch "On" + "Off" (10) Times
- 4) Ignition "Off"
- 5) Alarm will sound. Depress Button #1 or #2