

EB1217

Contents

Safety Precautions

Getting Ready

Basic Operation

Telephone

Appendix

This manual is based on the contents of Android™ 10.
For the latest version of the manual, refer to the "Online Manual" (Japanese) or
"取扱説明書 詳細版 (Full Instruction Manual)" (Japanese) on the au website.
<https://www.au.com/support/service/mobile/guide/manual/>

Preface

Thank you for buying the "EB1217" (simply called the "product" or "main unit" from here on). Before using the product, be sure to read the "Basic Manual" (this manual) to ensure correct use.

List of Packaged Items

Before your start using the product, make sure that you have all the following packaged with the product.



Main unit

- *かんたんマニュアル* (Kantan Manual) (Japanese)

* Desktop holder is not water/dust/shock resistant.

The following items are not included in the package.

- | | |
|-------------------|----------------------|
| ·AC adapter | ·microSD memory card |
| ·USB Type-C cable | ·Earphones |



memo

- Purchase a specified charger (sold separately).
- The battery is built into the product.
- Illustrations of cell phones in this manual are only for reference. They may look different from the actual product.

Operating Instructions

■ "Basic Manual" (This Manual)

Handles only basic operations for main features.

■ "Online Manual" (Japanese)

For detailed descriptions of various functions, refer to the "Online Manual" (Japanese) available on au homepage: Home screen → [サポート (Support)] → [取扱説明書 (Online Manual)]



For detailed descriptions of various functions, refer to the "Online Manual" (Japanese) available on the au homepage: <https://www.au.com/online-manual/kyv47/>

■ "取扱説明書 詳細版"

"(Full Instruction Manual)" (Japanese)

For detailed descriptions of various functions, refer to the "取扱説明書 詳細版 (Full Instruction Manual)" (Japanese) available on the au homepage:

<https://www.au.com/support/service/mobile/guide/manual/>



Regarding Notations Used in This Document



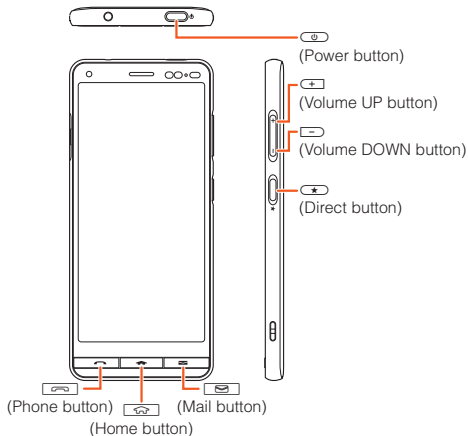

■ Note on Button Illustrations

In this manual, buttons are represented by simplified as shown below.



■ Description of Operations for Selecting Item/Icon/Button etc.

Notations used for operation procedures in this manual are as follows.

Description	Explanation
 → "DIALPAD" tab → [1] [4] [1] → [CALL]	Press  . And after tapping "DIALPAD" tab, tap "1", "4" and "1", then tap "CALL" at the end.
In sleep mode,  (Power button)	In sleep mode, press  (Power button).

- Tapping is to select a button or icon displayed on the screen by lightly tapping it with your finger.

■ Notes on Illustrations/Screenshots

In this manual, screenshots and operations for the product with au Nano IC Card 04 attached are described.

Screen illustrations shown in this manual may look different from the actual screens. Note that part of the screen etc. may be omitted.

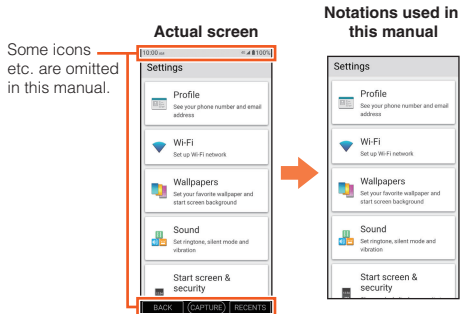

- In this manual, screenshots for body color "Champagne Gold" are provided as examples.
- In this manual, operations based on vertically oriented screens are provided as examples. With horizontally oriented screens, descriptions for menu item/icon/ onscreen button may be different.
- In this manual, "au Nano IC Card 04" is abbreviated as "au IC card".
- In this manual, "microSD™ memory card (commercially available)", "microSDHC™ memory card (commercially available)" and "microSDXC™ memory card (commercially available)" are abbreviated as "microSD memory card" or "microSD".
- All of the indicated amounts exclude tax unless otherwise specified.
- Company names and product names referred to in this manual are trademarks or registered trademarks of the respective companies. TM or ® may be omitted in this manual.
- Menu items, layers and icons described in this manual may be different according to functions and conditions to use.

Contents

Preface	ii
List of Packaged Items	ii
Operating Instructions	1
Regarding Notations Used in This Document	1
Contents	4
Safety Precautions.....	6
When Using the Product	6
Safety Precautions (Observe Strictly).....	8
Material List.....	18
Handling Precautions	19
Notes on Water, Dust, and Shock Resistance	26
Notes on Using Bluetooth®/Wireless LAN (Wi-Fi®) Function	32
Security Code/PIN Code.....	34
Notes on Data Communication Charges	35
Notes on Applications	36
Setting the App Permissions	36
Cell Phone Etiquette	37
Getting Ready	39
Names and Functions of Parts	39
au IC Card (SIM Card).....	41
Attaching/Removing au IC Card	42
Attaching/Removing microSD Memory Card	44
Charging	46

Turning the Power On/Off.....	52
Making Initial Settings	53
Making Initial Settings for au-mail.....	54
Using Wireless LAN (Wi-Fi®) Function.....	55
Switching to English Display	55
Start Screen.....	56

Basic Operations57

Using Touch Panel	57
Using Touch Keys	58
Using the Home Screen.....	59
Activating the Apps	59
Monitoring the Product's Status.....	60
Setting Silent Mode.....	61
Setting Airplane Mode	62
Checking Your Phone Number (Profile)	62
Using Screen Memo.....	62
Displaying Menu	63
Using the Direct Button	63
Using the One-touch button.....	63

Telephone65

Making a Call.....	65
Receiving a Call	65
Making a Call from Contacts.....	65

Appendix.....66

Updating Software	66
Troubleshooting.....	67
After-Sales Service	70

auスマートサポート (au Smart Support)	73
遠隔操作サポート (Remote Support).....	73
位置検索サポート (Location Search Support).....	74
SIM Unlock.....	74
Related Accessories	75
Using Earphones	75
Main Specifications	76
Specific Absorption Rate (SAR) of Cell Phones	77
FCC Notice	79
Export Administration Regulations.....	80
Intellectual Property Rights	80

Safety Precautions

When Using the Product

- Before you start using the product, make sure to read the "Safety Precautions" in this manual to ensure correct use.
- Before you assume that the product is malfunctioning, check for possible remedies in "クイック診断 (Quick check)" and "トラブル診断 (Trouble check)" on "故障紛失サポート (Repair and Delivery Support)" app.

■ Quick check

Home screen → [サポート (Support)] → [故障紛失サポート (Repair and Delivery Support)] → [クイック診断してみる (Try quick check)](Displayed language is Japanese only)

■ Trouble check

Home screen → [サポート (Support)] → [故障紛失サポート (Repair and Delivery Support)] → [便利な機能 (Useful functions)] → [トラブル診断を試す (Try trouble check)] (Displayed language is Japanese only)

Also available on the following au home page.

<https://www.au.com/trouble-check/> (in Japanese)



- Communication is not possible even inside the service area in places where the signal does not reach (e.g. tunnels and basements). Also, communication may not be possible in poor reception areas. Communication may be interrupted if you move into a poor reception areas during communications.
- Since this product uses radio waves, the possibility of communication intercepts by third parties cannot be eliminated (though the LTE/WiMAX 2+/GSM/UMTS system has highly secure confidential communication features).
- VoLTE (LTE network) by au is used when connecting with emergency call receiving agencies within Japan. You cannot connect using 3G (circuit-switched network).
- The product is compatible with au World Service. Each network service described in this manual varies depending on the area and service content.
- Since the product is a radio station under the Radio Law, you may be asked to temporarily submit the product for inspection in accordance with the Radio Law.
- The IMEI information of your cell phone is automatically sent to KDDI CORPORATION for maintenance and monitoring operational status of your cell phone.
- If you are using the product overseas, check the relevant laws and regulations of the country/region you visit beforehand.
- The Company is not liable for any damages arising from earthquakes, lightning, storms, floods or other natural disasters, as well as fires, actions by third parties, other

accidents, intentional or mistaken operation by the customer, or use under other unusual conditions outside the responsibility of the Company.

- The Company is not liable for any incidental damages (change/disappearance of described content, loss of business income, disruption of business, etc.) arising from use or inability to use the product.
- The Company is not liable for any damages arising from failure to observe the described content of this manual.
- The Company is not liable for any damages arising, for example, from malfunction caused by combination with connected devices or software not related to the Company.
- Captured image data or downloaded data may sometimes be altered or lost due to faults, repair or other handling of the product. The Company is not liable for any damage or lost income resulting from recovery of these data.
- It is recommended you keep a copy of important data in your PC's hard disk, etc. Whatever the cause of the defect or malfunction may be, the Company assumes no responsibility for alteration or loss of saved data.
- Contents saved in the product, such as contacts, mails and favorites, might be altered or lost by an accident, fault, repair or mishandling. Be sure to keep a copy of important contents. Note that the Company assumes no responsibility for any damages or lost profits resulting from altered or lost contents.

- Note that content data (both charged or free content) saved on the product cannot be returned to the customer when the product is replaced for repair of a fault, for example.
- The product's OLED display may experience changes in displayed color and viewing with long-period use. This occurs as remaining ghost images and burned-in images after a same screen is displayed for a long time. It is recommended that automatic brightness adjustment is turned on so the display is not at its brightest. You should also avoid displaying still images for a long time. It is recommended that you turn the display off when not in use, and that you set a short screen-out delay time.
- Display may appear to change hue or color somewhat when the product is held at a different angle, but this is a characteristic of OLED displays and is normal.
- Although the display used on the product is made using high-precision technology, some pixels (dots) might be lit or out at all times. This is not a malfunction.
- You are recommended to store copies of individual data such as photos/movies you took and music in your PC by sending each file as mail attachment, etc. Note, however, that you may not be able to make copies of some copyrighted data even by the above-mentioned means.
- Do not discard the product together with regular trash. Please cooperate in the collection of the product when the product is no longer needed to protect the environment and effectively use resources. The product

(including optional parts) is collected at au shops and other places.

- * "The Company" as appears in this manual refers to the following companies:
Sold by: KDDI CORPORATION-OKINAWA CELLULAR TELEPHONE COMPANY
Manufactured by: KYOCERA Corporation



- Reproduction of the content of this manual in part or in whole is prohibited.
- The content of this manual is subject to change without notice.
- Due to the specification changes of the operating system or termination of the services, some features become unavailable.
- Every effort has been made in the preparation of this manual. Should you notice any unclear points, omissions, etc., feel free to contact us.

Safety Precautions (Observe Strictly)

- Before using the product, thoroughly read this "Safety Precautions" for proper use.
- These precautions are intended to protect you and others around you. Read and follow them carefully to avoid injury, damage to the product or damage to property.
- The signs below differentiate between the levels of danger that can occur if the product is not used within the specified guidelines.



This sign denotes that "death or serious injury"^{*1} may directly result from improper use".



This sign denotes that "death or serious injury"^{*1} may result from improper use".









This sign denotes that "minor injury"^{*2} or damage to property"^{*3} may result from improper use".

*1 Serious injury: This refers to loss of sight, injury, burns (high- and low-temperature), electric shock, broken bones, injuries with residual aftereffects from poisoning, etc., and injuries requiring hospital admission for treatment or long term hospital attendance as an outpatient.

*2 Minor injury: This refers to injuries, burns (high- and low-temperature), electric shock, etc. that do not require hospital admission for treatment or long-term hospital attendance as an outpatient.



*3 Physical damage: This refers to extended damage to buildings, furniture, livestock, or pets.

■ Explanation of Graphic Symbols Used in This Manual

	Indicates an action that is not allowed.		Indicates that handling with wet hands is not allowed.
	Indicates that disassembly is not allowed.		Indicates an action based on instructions that must be done.
	Indicates that use in a place where the product is likely to get wet or allowing the product to get wet is not allowed.		Indicates that the power plug must be disconnected from the power outlet.

■ Precautions Common to the Main Unit, Internal Battery, Charger, au IC Card, Peripheral Devices

DANGER

-  **Do not use, store or leave the product in hot places (e.g. by the fire, near a heater, under a kotatsu or futon, in direct sunlight, in a car in the hot sun).**
Doing so may cause fire, burns, injuries, or electric shock.
-  **Do not put the product into or near a heating cooking device such as a microwave oven or IH cooker, or high-pressure container such as a pressure cooker.**
Doing so may cause fire, burns, injuries, or electric shock.
-  **Do not put sand, dirt, or mud on the product or put it on them directly. Do not touch the product with hands to which sand or others adhere.**
Doing so may cause fire, burns, injuries, or electric shock.
For details on water/dust resistance, refer to the following.
▶ P.26 "Notes on Water, Dust, and Shock Resistance"



Do not charge when the product is wet with water (drinking water, perspiration, seawater, urine of pet animals, etc.).

Do not use it near water, such as in a bathroom.

Doing so may cause fire, burns, injuries, or electric shock.

For details on water resistance, refer to the following.

▶ P.26 "Notes on Water, Dust, and Shock Resistance"



Do not subject the product to strong pressure or break the product. Especially when bringing the product putting in a pocket of clothes, do not let the product hit against surroundings or being put between the objects.

Doing so may cause fire, burns, or injury due to battery damage.

* Examples to avoid

- Sitting or squatting with the product put in a pocket of trousers or skirt
- Putting the product in a pocket of outer wear and catching them in a door or a door of car
- Stepping on the product on a soft object such as a sofa, bed, or bedding, or on a floor



Do not disassemble or modify in that manner.

Doing so may cause fire, burns, injuries, or electric shock.



Do not try to remove the product's internal battery.

Doing so may cause fire, burns, or injury.



Do not try to remove the product's back cover.

Doing so may cause fire, burns, or injury.



Do not let the product get wet with water (drinking water, perspiration, seawater, urine of pet animals, etc).

Doing so may cause fire, burns, injuries, or electric shock.

For details on water resistance, refer to the following.

▶ P.26 "Notes on Water, Dust, and Shock Resistance"



Do not put water (drinking water, perspiration, seawater, urine of pet animals, etc.) into the external device port, or in the connection port or USB plug on the desktop holder.

Doing so may cause fire, burns, injuries, or electric shock.

For details on water resistance, refer to the following.

▶ P.26 "Notes on Water, Dust, and Shock Resistance"



Use the optional products specified by au.

Not doing so may cause fire, burns, injuries, or electric shock.



Do not drop, trample, or throw the product or give a strong force or vibration to it.

Doing so may cause fire, burns, injuries, or electric shock.



Do not allow conductive materials (metal pieces, pencil lead, etc.) to come in contact with the external device port, or in the connection port or USB plug on the desktop holder, and do not allow dust to get inside.

Doing so may cause fire, burns, injuries, or electric shock.



Do not cover or wrap the product with bedding, etc. while using or charging the product.

Doing so may cause fire or burns.



If charging is not completed after the specified charging time, stop charging.

Overcharging may cause fire, burns, or injuries.



Make sure to turn off or stop charging the product before you get close to places where a flammable gas or dust can be generated.

Using the product in places where a flammable gas can be generated may cause an explosion or fire.



Follow the instructions given by the respective institution regarding the use of the product in a gas station.

Do not charge the product in a gas station. Be careful not to drop the product in a place like a gas station, especially when you put gas into a vehicle. Using the product in places where a flammable gas can be generated may cause an explosion or fire.



Perform the following operations while using, charging, or keeping the product if there are odors, noise, smoke, overheating, discoloring, deformation, or other abnormalities.

- Remove the power plug from the wall outlet.
- Turn the product off.

Not doing the above operations may cause fire, burns, injuries, or electric shock.



CAUTION



Do not use the damaged product.

Doing so may cause fire, burns, or injuries.



Do not leave the product on unstable or sloping surfaces. Be careful especially when the product is set to vibrate.

The product may fall and cause injuries.



Do not use or store the product in humid or dusty places, or places that get hot.

Doing so may cause fire, burns, or electric shock. For details on water/dust resistance, refer to the following.

▶ P.26 "Notes on Water, Dust, and Shock Resistance"



When children use the product, do not let them use incorrectly without instruction by an adult for proper use.

Doing so may cause injuries.



Do not store the product within the reach of small children.

Take particular care with where small parts such as the au IC card/microSD memory card tray are stored. Doing so may cause accidental swallowing, injuries, or electric shock.



Be careful when using the product continuously or charging as it gets hot. Also, avoid touching the product continuously while putting the product in a pocket of clothes or falling asleep unintentionally.

The product or specified charger (sold separately) may become hot when using applications, calling, doing data communication, watching videos continuously, or while charging. Depending on your physical predisposition and physical condition, contacting with a high temperature part continuously may cause skin redness, itching, rash, or low-temperature burns.

Main Unit



DANGER



Do not throw the product into fire or apply heat.

Doing so may cause fire, burns, or injuries.



Do not apply excessive force such as sticking a sharp-edged tool (nail, etc.) into the product, hitting it with a hard tool (hammer, etc.), or stepping on it.

Doing so may cause fire, burns, or injuries.



If the substance inside the product comes into contact with your eyes or mouth, immediately rinse the area with clean water, and then see a doctor right away.

Not doing so may cause loss of sight or poor physical condition due to the influence of the substance, etc. inside the product.



WARNING



Do not send data by infrared communication with the infrared port pointing toward eyes.

Doing so may adversely affect on eyes.



Do not operate to point the infrared port toward some other infrared household appliance when using infrared communication function.

Doing so may cause an accident, etc because of malfunction of infrared device.



Do not light or flash the lighting part of the light close to person's eye. Be especially careful to keep a sufficient distance from small children.

Not doing so may cause vision disturbance. Also, it may cause an accident such as injuries due to dizziness or startling.



Do not light or flash the light to point at the eyes of someone driving a car etc.

Doing so may interfere with driving and cause an accident.



Do not watch a repeatedly flickering screen for a long time.

Doing so may cause muscle spasms or loss of consciousness, etc.



Do not allow water or other liquids (drinking water, perspiration, seawater, urine of pet animals, etc.), metal pieces, flammable material or foreign object into slot for the au IC card/microSD card tray on the product.

Do not mistake the place and direction of the au IC card or the microSD memory card.

Doing so may cause fire, burns, injuries, or electric shock.



Do not expose the camera lens to direct sunlight for an extended period.

Doing so may cause fire, burns, or injuries by the light-collecting mechanism of the lens.



Turn off the product or set it to Airplane mode before going aboard an airplane.

Since using the product on airplanes is restricted, follow the instructions given by the respective airlines. The product's signals may adversely affect on-board electronic equipment.

If you commit a prohibited act while using the product on an airplane, you might be punished by law.



Follow the instructions given by the respective medical institution regarding the use of the product in a hospital.

Turn off the product in areas where the use of the product is prohibited.

The product's signals may affect electronic equipment and electronic medical equipment.



When using the handsfree call, ringtone is ringing, or in the standby mode, be sure to keep the product off of the ears.

Also, when playing games, video, or music with an earphone microphone connected to the product, adjust the volume to the proper level.

When using the handsfree call, loud noise sounds from the product.

Even in the standby mode, ringtone and vibrator may work suddenly.

Using continuously for a long time with too loud volume may cause a hearing loss, etc.

And, if you cannot hear the sound around you clearly, it may cause an accident.



If you have a weak heart, be careful when setting the ringtone vibration and incoming volume.

Sudden ringtone vibration and ringtone surprise you, it may cause harmful effect on heart.



To use electronic medical equipment, check with electronic medical equipment manufacturer or vendor to determine how devices are affected by radio waves before using.

Not doing so may cause harmful effect on electronic medical equipment etc.



Turn the product off near high-precision electronic control equipment or electronic equipment using low-power signals.

Not doing so may cause the equipment to fail or malfunction.

- * Examples of electronic equipment to avoid
A hearing aid, an implanted pacemaker, an implanted cardioverter-defibrillator, other electronic medical equipment, or other automatic control devices, etc. To use an implanted pacemaker, an implanted cardioverter-defibrillator, or other electronic medical equipment, check with electronic medical equipment manufacturer or vendor to determine how devices are affected by radio waves before using.



When the display or camera lens is accidentally broken, be careful of broken glass or exposed internal parts of the product.

Not doing so may cause burns, injuries, or electric shock with damaged parts or exposed parts.



If the internal battery leaks or gives off a strange smell, immediately discontinue use and remove the product from the vicinity of open flames.

Not doing so may cause leaking fluid to ignite or explode.



Be careful not to let your pet bite the product.

May cause internal battery to ignite, burst, heat, or leak, and may cause fire, burns, or injuries.



CAUTION



Do not swing the product around by holding strap, etc.

Doing so may cause injuries or other accidents.



If the display breaks and the fluid, etc. leaks out from inside, do not let the fluid contact with the skin on your face or hands or clothes.

Doing so may harm your eyes or skin.

If the substance inside the display enters your eyes or mouth, or gets on your skin or clothes, immediately rinse the area with clean water.

If the substance enters your eyes or mouth, rinse and immediately see a doctor.



Do not discard the old product together with regular trash.

Doing so may cause fire, burns, or injuries. Also, may cause environmental disruption. Bring them to a sales outlet such as au Shop. If your local municipality has a battery recycling program, dispose of them as provided for.



If fluid etc. leaks out from the internal battery, do not let the fluid contact with the skin on your face or hands, or clothes etc.

Doing so may cause eye or skin problems.

If the substance inside the internal battery enters your eyes or mouth, or gets on your skin or clothes, immediately rinse the area with clean water.

If the substance enters your eyes or mouth, rinse and immediately see a doctor.



To use the product in car, check with automobile manufacturer or dealer to determine how vehicle devices are affected by radio waves before using. In rare cases, using the phone in some vehicle models can cause the vehicles electronic equipment to malfunction. In that case, stop using the product immediately.



If you develop skin problems, stop using the product immediately, and see a doctor.

Itching, rashes, eczema, etc. sometimes occurs depending on your physical constitution and condition.

For material of each part ▶ P.18 "Material List"



Make sure that there are no adhered metal pieces (cutter blade, staples, etc.) as the receiver/speaker and out camera (lens) of this product use parts that are magnetic.

Not doing so may cause injuries with adhered metal pieces.



Use the product in a well-lighted area and put some distance between you and the display when watching the display.

Using the product in dark places or near eyes may affect your vision.

Charger



WARNING



Do not use if the cord of the specified charger (sold separately) is damaged.

Doing so may cause fire, burns, or electric shock.



Do not touch the specified charger (sold separately) if you hear thunder.

Doing so may cause electric shock.



Do not short the USB plug while the desktop holder is connected to an outlet. Do not allow any part of your body such as your hands or fingers to come into contact with the desktop holder.

Doing so may cause fire, burns, or electric shock.



Do not place heavy objects on the cord of the specified charger (sold separately), or do not pull the cord with excessive force.

Doing so may cause fire, burns, or electric shock.



When you plug/unplug the specified charger (sold separately) into/from the outlet, do not contact metal straps or other metal objects with the jack.

Doing so may cause fire, burns, or electric shock.



Do not connect a transformer for overseas travel (travel converter) to the specified charger (sold separately).

Doing so may cause ignition, overheating, or electric shock.



Do not apply excessive force on the connection part with the specified charger (sold separately) connected to the product.

Doing so may cause fire, burns, injuries, or electric shock.



Do not touch the cord or power plug of the specified charger (sold separately), or desktop holder with wet hands.

Doing so may cause fire, burns, or electric shock.



Use the product at the specified power supply voltage.

When charging the product overseas, use the specified charger (sold separately) for global use.

Incorrect power supply voltage may cause fire, burns, or electric shock.

AC adapter : 100 V AC (Connect to an AC outlet for internal household use)

AC adapter for global use : 100 V AC - 240 V AC (Connect to an AC outlet for internal household use)



Wipe off dust on the power plug.

Not doing so may cause fire, burns, or electric shock.



Fully plug the specified charger (sold separately) into the outlet.

Not doing so may cause fire, burns, or electric shock.



When you disconnect the power plug from an outlet, do not pull the cord of the specified charger (sold separately) with excessive force. Instead, grasp the adapter to disconnect.

Pulling the cord of the specified charger (sold separately) may damage the cord and cause fires, burns, electric shock, etc.



When plugging/unplugging the specified charger (sold separately) into/from the product, do not pull the cord with excessive force. Instead, plug/unplug it straightly toward the jack to connect.

Not doing so may cause fire, burns, injuries, or electric shock.



Stop using the desktop holder immediately if you notice deformation of the USB plug. Also, do not try to use the desktop holder after returning the plug to its original shape.

Short-circuiting of the USB plug on the desktop holder may cause fire, burns, injuries, or electric shock.



When the specified charger (sold separately) is not to be used for a long time, disconnect the power plug from the outlet.

Not doing so may cause fire, burns, or electric shock.



Immediately remove the power plug from the outlet if water or other fluids (drinking water, perspiration, seawater, urine of pet animals, etc.) get on the adapter.

Short-circuiting due to the fluid may cause fire, burns, or electric shock.



Always remove the power plug from an outlet when cleaning the equipment.

Not doing so may cause fire, burns, or electric shock.

CAUTION



Do not keep touching continuously the specified charger (sold separately) when it is connected to an outlet.

Doing so may cause burns.

■ au IC Card

CAUTION



Be careful of the cut surface when handling an au IC card as it may damage a part of your body such as fingers, etc.

The cut surface may be sharp, and it may cause injuries.

■ Use near Medical Instruments and Inside Medical Facilities

WARNING



Wearers of medical equipment such as implanted pacemakers or defibrillators must carry and use the product at least 15 cm away from the implanted device.

Radio waves may affect the performance of electronic medical equipment.



When using electronic medical devices as home medical treatment other than an implanted pacemaker and an implanted cardioverter-defibrillator outside medical facilities, check individually with the manufacturer of the electronic medical equipment regarding the influence of radio waves.

Radio waves may affect the performance of electronic medical equipment.



Make sure that the product will not emit any signals (turn off power, put it in Airplane mode, etc.) if within 15 cm of those around you, such as where crowded and you cannot move freely.

Since there may be people with an implanted pacemaker or an implanted cardioverter-defibrillator nearby. Radio waves may affect the performance of electronic medical equipment.



When using the product in medical facilities, be sure to observe the regulations of the facility.

Radio waves may affect the performance of electronic medical equipment.

Material List

■ EB1217 main unit

Part	Material	Surface Treatment
Exterior case (side)	PA resin	UV cured acrylic coating
Exterior case (bottom, back, Phone button, Home button, Mail button, Power button, volume up / down button, Direct button)	PC resin	UV cured acrylic coating
Display	Chemically strengthened glass	Antismudge hard coating
Camera ring	Aluminum alloy	Anodizing

Part	Material	Surface Treatment
Out camera (lens)	PMMA resin	Hard coating
Photo light / Light	PMMA resin	-
au IC card/microSD memory card tray	POM resin	-

Handling Precautions

These precautions are provided to prevent product faults and to ensure that performance can be fully demonstrated. Thoroughly read these precautions to ensure correct use.

■ Precautions Common to the Main Unit, Internal Battery, Charger, au IC Card, Peripheral Devices

- Do not apply excessive force to the product during use. Be sure not to put the product into a tightly packed bag or place a heavy object on the product in a bag. Sitting on the product in your pocket might damage the display or internal circuit board resulting in a malfunction. Keeping an external connection device connected to the external connection terminal or earphone microphone terminal might damage the connector resulting in a malfunction. Such damage and malfunction are not covered by the warranty, even if there is no external damage.
- To ensure the water resistance (equivalent to IPX5 and IPX8) or the dust resistance (IP6X) of the product, use the product with the au IC card/microSD memory card tray tightly closed. Note that resistance is not guaranteed in every usage condition. Do not allow water to get inside the product, or splash water on a specified charger (sold separately) or optional accessories. Do not open/close the au IC card/microSD memory card tray in the rain or with any water on the surface of the product. Doing so may cause water intrusion resulting in internal corrosion. Malfunctions determined to be caused by such water intrusion are not covered by the warranty.

- Do not use the product in extremely hot, cold or humid places. (Use within an ambient temperature range of 5°C to 35°C and humidity range of 35% to 90%. Temporary use at 36°C to 40°C is allowed.)
 - Main unit
 - au IC card (attached to the main unit)
- Do not use the product in extremely hot, cold or humid places. (Use within an ambient temperature range of 5°C to 35°C and humidity range of 35% to 85%.)
 - Charger
 - Peripheral devices
- Do not use in places subject to lots of dust or vibration. Doing so may cause malfunction.
- Clean the product's external device port and earphone microphone terminal, as well as the desktop holder's connection port or USB plug with dry cotton swabs, etc. every now and then. Soiling may result in a poor connection. Do not exert a strong force to clean each of the terminals to prevent deformation.
- Clean the product with a soft dry cloth (such as the type used for eyeglasses). Forceful rubbing with a dry cloth may scratch the display. The display may be stained if splash or smear is left attached to the surface. Wiping the product using alcohol, thinner, benzene, detergent, glass cleaner, etc. might erase the printing on the outer cover or cause malfunction.
- Use as far away as possible from land-line phones, TVs and radios. Use nearby might affect them.

- The product may become warm while charging or during other operations, depending on the situation, but this is not abnormal.
- When placing the product on the desktop holder, do not press it in or use excessive force. Doing so may scratch the product or result in a poor connection.
- While the product can be charged in the desktop holder while its power is on, charging takes quite a longer time.
- Do not place near corrosive chemicals or in places where corrosive gas is generated. Doing so may cause malfunction.
- Do not use outside when you can hear thunder. Doing so might risk lightning strikes and electric shock.
- Be sure to use only the specified peripheral devices. Use of other peripheral devices might cause malfunction.
- Do not put the product in a cooking apparatus such as microwave oven or a pressure vessel. Doing so may cause malfunction.
- The customer is not allowed to disassemble, modify or repair the product. Doing so may cause malfunction. Modification of the product is in violation of the Radio Law and Telecommunications Business Law.
- Do not allow any part of yourself (fingers, etc.) or conductive foreign objects (metal fragments, pencil leads, etc.) to come into contact with or get inside the product's external device port or earphone microphone terminal, or the desktop holder's connection port or USB plug, to avoid short-circuiting. Doing so may cause malfunction.

- In the event that the product gets wet while charging, immediately disconnect the power plug of the specified charger (sold separately).
- Do not use the product while driving a car or motorbike, riding a bicycle or walking. Use of a cell phone while driving a car or motorbike is prohibited by law. Use of a cell phone while riding a bicycle may be punishable by some regulations.
- Using or charging the product in a bag or while it is covered with bedding might cause malfunction.
- When using a specified charger (sold separately) or external device, insert/remove the connector straight to/from the terminal. Make sure the orientation of the connector. Unless it's correct, it may cause a fault.
- Do not expose the camera lens to direct sunlight for an extended period. Doing so may cause malfunction.
- Do not use, store, or leave the product in places subject to direct sunlight (e.g. in a car), places that get hot, places that get extremely cold, and in humid or dusty places. Doing so may cause malfunction.
- Do not leave the product on unstable or sloping surfaces. Be careful especially when the product is charging or set to vibrate. The product may fall and cause malfunction.
- For charging the product, do not exceed the rating of an outlet or wiring device when using a power bar, etc.

■ Main Unit

- The battery is built into the product and it is not user replaceable. For information on battery replacement, contact an au shop or Customer Center.

● Do not forcefully press, tap or intentionally subject the display to strong impact. Doing so might cause scratching or damage.

● Do not forcefully press your fingernails, sharp objects, or hard objects against buttons or display surface. Doing so may cause scratching or damage.

● The touch panel is designed to be lightly touched by fingers. Avoid pressing forcefully or using sharp objects (fingernail, ballpoint pen, pin, etc.).

● Never use the modified product. Use of a modified device violates the Radio Law and Telecommunications Business Law.
The product has acquired such certification as conformity with technical regulations for a specified radio station based on the Radio Law and conformity with technical regulations for a terminal device based on the Telecommunications Business Law, and the "Technical Conformity Mark" can be confirmed internally in the au mobile phone.
Home screen → [Settings] → [More] → [Compliance information]
If the modification is made to the internal components, the certifications of conformity with technical regulations will become invalid. Never use the product without these certifications valid. Doing so violates the Radio Law and Telecommunications Business Law.

● Take care not to place magnetized items such as magnetic cards, speakers and TV sets near the product as it might cause malfunction.
Putting strong magnetism close to the product might cause false operation.

● Do not bring magnetized cards such as cash cards, credit cards and prepaid cards closer to the product. Doing so may result in loss of recorded information.

● When you put the product in your pocket or bag, take care so that the display does not come in contact with metal objects or other hard objects. Not doing so may cause scratching or damage. Straps with metal or other hard parts that may come in contact with the display may cause scratching or damage.

● When suddenly brought into a warm place from a cold place, or when in a humid location, or when used where temperature suddenly changes (e.g. near the air discharge port of an air conditioner), water droplets (i.e. condensation) sometimes are formed inside the product. Note that when used under conditions such as this, humidity might cause corrosion or a fault.

● Camera lens or inside of the display may mist over (dew formation) because of usage environment such as temperature or humidity. This is not malfunctioning or abnormal.

- Environment for easily generating dew formation on the camera lens or inside of the display
In the following cases, such as large temperature change or high humidity, camera lens or inside of the display mist over because of usage environment.
 - Bring the product from a high temperature land into a low temperature water.
 - Bring the product from a cold place into a warm place such as an indoor.
 - Open/close the au IC card/microSD memory card tray in a high humidity environment.
- How to reduce condensation
Avoiding any place that gets hot and humid, or sandy or dusty, leave the product where the ambient temperature is held constant with the au IC card/microSD memory card tray opened for a while until the condensation is cleared.
- While writing/reading data to/from a microSD memory card, do not subject the product to vibration or impact, or turn off the power. Doing so may cause data loss or malfunction.
- Do not cover the light sensor with your finger or put a sticker on it. May hinder the sensor from detecting the ambient light level and functioning correctly.
- Do not put a sticker, etc. on the proximity sensor. May cause the sensor to malfunction and make the display always turned off while receiving a call or during a call and make it impossible to operate the product.
- Any soiling on the proximity sensor may cause misoperation. Wipe the sensor with a soft, dry cloth.

- Keep the au IC card/microSD memory card tray closed when using the product. Using the product with the tray opened can allow dust, liquid, etc. to enter and cause malfunction.
- Do not allow liquids, metal objects, or other foreign objects to get inside of the slot for the au IC card/microSD memory card tray. Doing so may cause malfunction.
- Do not give strong impact on the product such as dropping, throwing, stomping. Doing so may cause malfunction.
- Do not place the product directly on sand at a beach, etc. If sand or other small particles get inside the mouthpiece (microphone) or receiver/speaker, etc., it may cause the volume to drop, or cause the product to malfunction if they get inside.

■ Touch Panel

- Any soiling on the display surface may cause false operation. Wipe the display with a soft, dry cloth.
- Putting stickers or sheets (e.g. commercially available protective films, peep prevention sheets) on the display might cause incorrect operation of the touch panel.
- When carrying the product in your pocket or bag, take care not to put the touch panel close to metals or other conductive materials, as it might cause false operation of the touch panel.

■ Internal Battery



Li-ion 00

(The internal battery of the product is a lithium-ion battery.)

The internal battery is not fully charged at the time of purchase. Charge the battery before using the product. Also charge the battery after long periods of disuse before using the product.

- Use in very hot or cold environments, for example, when left in an automobile with the windows closed in summer, will cause the battery capacity to drop and shorten the available battery usage time. This will also shorten the internal battery's service life. Try to use the internal battery as much as possible at room temperature.
- After the internal battery is charged, battery power decreases bit by bit even if the product is not used. The internal battery may be discharged if the product is not used for a long time. We recommend charging the battery before use.
- The internal battery is a consumable accessory. If the performance of an internal battery does not recover (e.g. the usable time after each charge has become extremely short), the internal battery is at the end of service life, so stop using the product. Since the battery is built into the product, au shops keep your product and replace the battery for a fee. Please note that you may not be able to use the product for a certain period. Please understand. Note that the length of service life varies depending on the usage condition, etc.

- The internal battery may swell up as it approaches the end of its battery life. This is due to the properties of lithium-ion batteries, and is not a problem in terms of safety.

■ Charger

- Do not wrap the cord of the specified charger (sold separately) around the desktop holder or adapter unit. Do not forcibly bend the specified charger's (sold separately) plug or the connection between the connector and power cord. Do not place heavy objects on the cord of the specified charger (sold separately) or USB connection cable, or do not pull the cord with excessive force. Doing so may cause malfunction.
- When unplugging the power plug of the specified charger (sold separately) from the power outlet, hold and pull the power plug. If you pull the cable, it might be damaged.

■ Desktop Holder

- Contains magnet; do not bring magnetic stripe cards near.
- May not be placeable in Dock Mode if a strong magnet is nearby.
- May exit Dock Mode if a strong magnet is brought near.
- Do not use in a vehicle. It can fall and hinder driving, causing an accident. Assumes use indoors on a stable surface.
- Is not water resistant. Do not expose to water or other liquid. Never use in a humid place such as a bath room or with wet hands. Doing so may short-circuit or corrode circuitry.

■ au IC Card

- Do not forcibly remove or insert the au IC card. Be careful not to exert excessive force when inserting the card into your au cell phone.
- You are responsible for any damage caused by inserting your au IC card into some other IC card reader/writer, etc.
- Do not put stickers, etc. on the au IC card.
- Do not insert the au IC card inserted in a card adapter. Doing so may cause malfunction.
- Do not damage the card (use in a hot place, throw into fire, contact the metal part with foreign object, give an impact, bend, apply a load, moisten, etc.). Doing so may cause data loss or malfunction.

■ Camera

- When photographing important occasions, take a trial shot and check the shot image to make sure it is correctly shot.
- Do not shoot in areas where shooting is prohibited.

■ Copyrights and Rights of Portrait

- You are not allowed to copy, distribute, publish, modify or edit the data you shot, recorded or downloaded using the product without consent of the copyright holder, except for personal use, under the copyright law.
In addition, do not use or modify portraits or names of other individuals without their consent, as it may infringe on rights of portrait.
Note that shooting and recording might be restricted at some live performances, shows and exhibitions even for personal use.
- Be careful about the copyright and portrait right when posting images you shot, etc. on Internet/ website.

■ Backup Content On the Product

- Please back up important content registered to the product or downloaded to the product from an outside source.
Content recorded to memory on the product sometimes disappears or is altered by unexpected factors, such as static electricity or a fault, repair, mishandling, etc.

■ FCC Certification Information

- The product is certified by Federal Communications Commission (FCC)
The product's FCC ID is JOYEB1217.
You can view this certification in the following way.
How to confirm:
Home screen → [Settings] → [More] → [Compliance information]

Notes on Water, Dust, and Shock Resistance

The product has protection class (JIS C 0920) ratings of IPX5^{*1} and IPX8^{*2} equivalent water resistance, as well as IP6X^{*3} equivalent dust resistance on the condition that the au IC card/microSD memory card tray is completely attached (by Company test methods).

The product also achieves shock resistance compliant with MIL standards^{*4} (by Company test methods).

Before using the product, thoroughly read "Important precautions before use" to ensure correct use. Failure to follow the contents described in these sections may cause the intrusion of water, sand or other foreign material, resulting in overheating, ignition, electric shock, injury or a fault.

^{*1} IPX5 equivalent means that the product will maintain its operability as a phone even if it is sprayed with water from a 6.3 mm diameter nozzle at a distance of about 3 meters for more than 3 minutes at a rate of about 12.5 liters per minute from any direction.

^{*2} IPX8 equivalent means that the product will maintain its operability as a phone with no water getting inside the main unit even if it is gently submerged in a tank of still tap water at room temperature to a depth of 1.5 meter for about 30 minutes.

^{*3} IP6X equivalent means that the product has ability to resist penetration by particles (75 μ m or less in diameter) in a test device for 8 hours.

^{*4} MIL standards compliance

Drop test (product dropped from 1.22 m in 26 directions) complying with MIL-STD-810G Method 516.7-Shock as established by the US Department of Defense.

* Designed with shock resistance for normal daily use; note that product may break if subjected to excessive force such as being thrown or

dropped unreasonably. Even if the product continues to function, impact from being dropped can cause scratches.

Operation of the product in every possible condition during actual use is not guaranteed. Malfunctions determined to be caused by mishandling by the customer are not covered by the warranty.

Important Items to Remember before Use

- Close the au IC card/microSD memory card tray securely. Product is water resistant when tray is closed completely.
- Never open/close the au IC card/microSD memory card tray when your hands or the product is/are wet.
- Do not let the product submerged into or get wet with the liquids (seawater, water from a swimming pool, hot water of hot spring, water containing soap, detergent, bath powder, alcohol, soft drink, seasoning, etc.) other than tap water. Also, do not use it in a place where it gets wet with pet urine. If the product gets splashed, immediately rinse it off with tap water.
- Do not place the product directly on sand at a beach, etc. Sand or other small particles might get inside the mouthpiece (microphone) or receiver/speaker, causing the volume to drop. If sand gets inside the product, it might cause overheating or a malfunction.
- Do not use the product underwater.

- Do not use or leave the product in a humid place such as a bathroom or kitchen for an extended period of time.
- Moisture may still remain after draining. While this will not affect use, you should not leave the product next to items you do not want to get wet. Product may wet clothing, inside of carry bag, etc.
- Drain any water in the mouthpiece (microphone), receiver/speaker, etc. that may be affecting audibility.
- Product is not designed to resist water pressure. Avoid exposing to high water pressure or submersing in water for a long period.
- Do not wash the product in a washing machine or ultrasonic bath.
- Do not immerse the product into a bathtub. Product is not designed to be heat resistant.
- The rapid changes of temperature may cause condensation, resulting in malfunction. Wait until the product reaches room temperature before you bring the product from a cold place into a warm bathroom.
- The product does not float on water.
- **au IC card/microSD memory card tray**
 - Close the au IC card/microSD memory card tray securely, and make sure it is completely closed. Any minute particles becoming lodged between contact surfaces (a single hair, etc.), no matter how small, can cause seepage.
 - Do not wear gloves while opening/closing the au IC card/microSD memory card tray. Any minute particles becoming lodged between contact surfaces (a single hair, etc.), no matter how small, can cause seepage. Before closing the tray,

wipe any water, soiling, etc. with a dry, clean cloth, no matter how small.

- Any deterioration or damage with the au IC card/microSD memory card tray will affect water resistance.

How to close the au IC card/microSD memory card tray

Insert the au IC card/microSD memory card tray in the product, and push in all the way without bending.

After inserting the tray, ① press all of the tray with the flat part of your finger. ② Rub your finger over the tray in the direction of arrow to ensure that the tray is not partially open.

Rub your finger over the tray in the direction of arrow to ensure that the tray is not partially open.

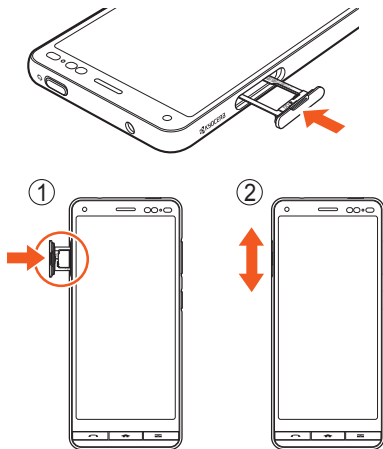
**● If any liquid other than plain water gets on the product**

- If anything other than water (seawater, washing detergent, alcohol, etc.) gets on the product, immediately rinse with water.
- Wash with slightly weak running water (less than 6 liters/minute) with tap water (5°C to 35°C) at a position about 10 cm away from the faucet or shower.
- If the product gets soiled, wash by hand without using a brush, etc., holding the product so that the au IC card/microSD memory card tray does not open.

● After the product gets wet

- After becoming wet, drain water and wipe the product with a dry, clean cloth.
- In cold regions, any water on the product may freeze. Using the product with frozen water may cause malfunction. Do not leave water drop on the product.

● Rubber seal

- The rubber seal around the au IC card/microSD memory card tray is important in maintaining water resistance. Do not scratch or remove it.
- Be careful not to pinch the rubber seal when closing the au IC card/microSD memory card tray. Trying to close the tray with a seal pinched can scratch the seal and affect water resistance. Any minute particles becoming lodged between contact surfaces (a single hair, etc.), no matter how small, can cause seepage.

- Any liquid other than water (alcohol, etc.) on the product can affect product durability.
- Do not insert pointed objects in the au IC card/microSD memory card tray. Doing so may damage/deform the product or scratch the seal, allowing water seepage.
- Parts used for maintaining water resistance should be replaced every 2 years regardless of their appearance. Contact your nearest au shop for replacement.

● Heat resistance

- Do not submerge the product in hot water or get it wet with hot water. Do not use the product in saunas or expose it to hot air from hair dryer etc. Product is not designed to be heat resistant.

● Dust resistance

- If dust gets on the product, immediately rinse with water and completely remove any dust before using the product.

● Shock

- While the product is resistant to shock, it is designed with shock resistance for normal daily use; note that product may break if subjected to excessive force such as being thrown or dropped unreasonably.

Precautions on Charging

Optional accessories are not water/dust resistant. Note the following before and after charging.

- Never charge the battery if the product is wet. Doing so may cause fire, burns, injuries, electric shock, etc.
- Make sure the product is not wet. To charge the product after it has gotten wet, drain water well and wipe with a dry, clean cloth before inserting the USB Type-C plug into the external connection terminal or placing in the desktop holder.
- Check that no water or foreign objects are in the external connection terminal before use.
- Do not touch the specified charger (sold separately) or desktop holder with wet hands. Doing so may cause electric shock.
- Do not expose the specified charging equipment (sold separately) or desktop holder to water. Do not use it near water, such as in a bathroom, shower room, kitchen, or washroom. Doing so may cause fire, burns, electric shock, or malfunction. Do not bring it into a bathroom, etc. even when you are not charging with them. Doing so may cause fire, burns, electric shock, or a malfunction.

How to Drain Water

If the product gets wet, be sure to drain the mouthpiece (microphone) and receiver/speaker.

Water remaining in those parts might wet your clothes or bag, or the sound might become hard to hear.

Follow the steps below to drain water.

1 Wipe water thoroughly on the surface of the product with a clean dry lint-free cloth

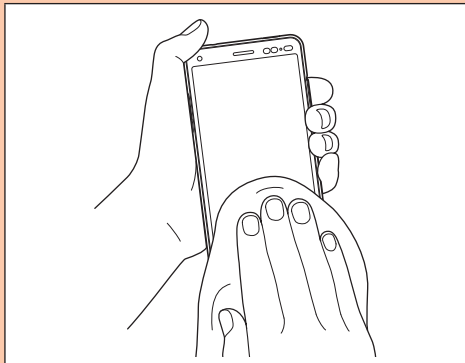

2 Shake the product

- ① Hold the product firmly and shake it in the direction of arrows until water does not come out.
 - * When shaking the product, stay alert to your surroundings.
 - * Be careful not to have the product pop out, and hold it firmly to drain water.

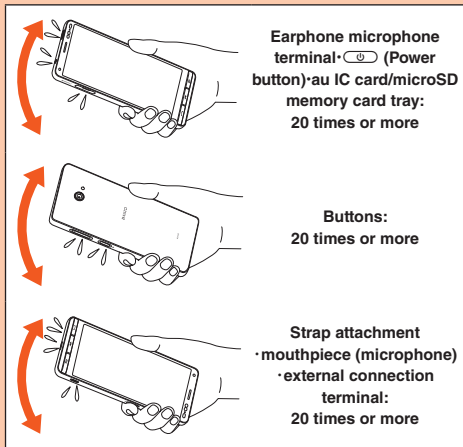

- ② Wipe drained water.
- * The mouthpiece (microphone), receiver/speaker, external device port, earphone microphone terminal, and buttons are particularly hard to drain water from.
- With those parts facing down, press them against the cloth to wipe off any water.
- ③ Place the product on a dry towel or cloth, then leave it at room temperature for a while.

3 Press the product gently against a clean dry lint-free cloth, and wipe off water remaining in the gaps such as in the mouthpiece (microphone), receiver/speaker, external device port, earphone microphone terminal, etc.

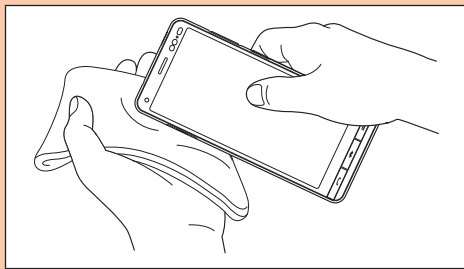

4 Leave the product on a dry towel or cloth for 1 hour or more at room temperature to dry after removing drained water thoroughly

Even after you take these procedures, water may remain on the product. Do not place the product near things that you do not want to wet.

Also, take care not to wet your clothes, bag, etc.

Notes on Using Bluetooth®/ Wireless LAN (Wi-Fi®) Function

- The product's Bluetooth® function is certified as conforming with Japanese domestic and FCC standards.
- Use of the Bluetooth® function is limited in some countries or regions. If you use the product overseas, check the relevant laws and regulations of the country/region you visit.
- The product's wireless LAN (Wi-Fi®) function is certified as conforming with Japanese domestic and FCC standards.
- Use of the Wireless LAN (Wi-Fi®) function is limited in some countries or regions. If you use the product overseas, check the relevant laws and regulations of the country/region you visit.
- The 2.4 GHz band used by wireless LAN (Wi-Fi®) and Bluetooth® devices is operated by various other devices. For this reason, the communication speed and connectable range may be decreased, or disconnection may occur, due to interference from other devices.
- Do not use this product in places where electromagnetic waves are generated or near electric products, AV and OA equipment, or other magnetized devices.
- Subjecting this product to magnetic or electrical noise might increase noise or prevent it from performing communications. (This product is particularly susceptible to noise when it is used near a microwave oven.)

- Using this product near a TV, radio or similar appliance might cause reception interference and disrupt TV images, etc.
- Searching might not be successful if there are multiple wireless LAN (Wi-Fi®) access points near to the product or the same channel is being used.
- Since using the product on airplanes is restricted, follow the instructions given by the respective airlines.
- The communication speed and connectable range vary depending on the distance between communication devices, obstacles and the devices used.

IEEE802.11b/g/n

IEEE802.11a/n/ac

J52	W52	W53	W56
-----	-----	-----	-----

Cautions on Using 2.4 GHz Band

The frequencies used by the Bluetooth® and/or Wireless LAN (Wi-Fi®) function of the product are in the 2.4 GHz band. In this frequency band, other similar wireless stations, in-plant wireless stations for mobile unit identification that require a license for use, such as factory production lines, specific small power wireless stations that do not require licenses, amateur wireless stations (collectively called "other wireless stations" from here on) are operated in addition to home electrical appliances such as microwave ovens, devices for industrial, scientific and medical devices.

1. Before using the product, make sure that "other wireless stations" are not in operation nearby.
2. In the event that instances of radio wave interference have occurred between the product and "other wireless stations", immediately either relocate the product or stop operation of the device (stop emission of radio waves).
3. If unsure or require assistance, contact an au shop or Customer Center.



memo

- ◎ Connections between the product and all other Bluetooth® and wireless LAN (Wi-Fi®) devices have not been confirmed. Therefore, connections with all Bluetooth® and wireless LAN (Wi-Fi®) devices are not guaranteed.
- ◎ This product supports security features for wireless communications that are compliant with the Bluetooth® and wireless LAN (Wi-Fi®) standard specifications, but the security may not be sufficient depending on the usage environment and configuration. Be careful when making data communication using Bluetooth® or wireless LAN function (Wi-Fi®).
- ◎ Wireless LAN (Wi-Fi®) has the advantage that it can be freely connected anywhere within the radio wave range, as it uses radio waves for exchanging information. However, not making security settings allows the risk of malicious use by third parties. While at the customer's discretion and responsibility, it is recommended that you make security settings before using the product.
- ◎ The Company assumes no responsibility for leakage of data or information that may occur during Bluetooth®/ wireless LAN (Wi-Fi®) communication.
- ◎ Since Bluetooth® and wireless LAN (Wi-Fi®) functions use the same frequency band, using the both functions at the same may cause radio wave interference resulting in decreased communication speed or disconnection from the network. If connection fails, stop using either of the Bluetooth® and wireless LAN (Wi-Fi®) functions.

Bluetooth® and wireless LAN (Wi-Fi®) functions of the product use frequencies in the 2.4 GHz band.

• **Bluetooth® function: 2.4FH1/XX1**

2.4FH1/XX1

This product uses the 2.4 GHz band. FH-SS is used as the modulation scheme. The interference distance is about 10 m or less.

The band of mobile unit identification devices cannot be avoided.

• **Wireless LAN (Wi-Fi®) function: 2.4DS4/OF4**

2.4DS4/OF4

This product uses the 2.4 GHz band. DS-SS and OFDM are used as the modulation schemes. The interference distance is about 40 m or less.

This means that all bandwidths are used, and that band of mobile unit identification devices can be avoided.

Available channels vary depending on countries. For use in an airplane, check with the airline company in advance. If country information cannot be discerned such as if in Airplane mode, Wi-Fi channels 12 and 13 are not available.

Cautions on Using 5 GHz Band

Outdoor use of 5.2 GHz band and 5.3 GHz band (W52/W53) is prohibited under the Radio Law.

Excludes communication with the base stations or land mobile relay stations of high-output data communications systems operating in the 5.2 GHz band.

The used channels of the product are as follows.

- W52 (5.2 GHz band / 36, 40, 44, 48 ch)
- W53 (5.3 GHz band / 52, 56, 60, 64 ch)
- W56 (5.6 GHz band / 100,104,108,112,116,120,124,128, 132,136,140 144ch)

Security Code/PIN Code

Security Code

The product has various security codes that you can use. The available security codes are as follows. Do not forget the various security codes that are set as they are necessary for various operations and contracts. Be sure to change the initially set number to your own number.

● Security code

Example of usage	①To do remote operation of voice mail and call forwarding services from a landline phone
	②To use Customer Center and to do various inquiries, applications, and modifications on the au homepage

Initial value	A four digit number chosen by the customer and noted on the application form
---------------	--

● Setting security for the start screen

Example of usage	Activating/deactivating the security
Initial value	According to initial setting at the time of purchase

PIN Code

PIN Code

To prevent unauthorized use of the au IC card by a third party, you can set the product to require PIN code entry every time the power is turned on. You also need to enter PIN code when setting whether PIN code entry is required. If PIN code is incorrectly entered three times consecutively, the PIN code will be locked. You can unlock the PIN code using PUK code.

- At the time of purchase, the PIN code is "1234", and entry is not required. You can change the PIN code to any 4- to 8-digit number and the product to require entry if necessary.
- To use the product with a PIN code required, be sure to change the PIN code to your own number you have chosen.

PUK Code

In case PIN code is locked, you can unlock it by entering

PUK code.

- PUK code is an 8-digit number given at the time of purchase, which is printed on the back side of the plastic card on which your au IC card is attached.
- After entering PUK code, you need to set a new PIN code.
- If PUK code is incorrectly entered ten times consecutively, contact an au shop, Toyota store dealing in au, or Customer Center.
- PIN code is not reset by initializing the product.

Notes on Data Communication Charges

- Since constant Internet connection is possible with the product, data communication may be performed automatically by some applications, resulting in high data communication charges. Therefore, subscription to a data flat-rate service/data communication charge discount service is recommended.
- To browse homepages, download applications, communicate using applications, send/receive mails and configure various settings with the product, connection to the Internet is required, to which data communication charge applies.

* Data communication charge does not apply if connected by wireless LAN (Wi-Fi®).

Notes on Applications

- Be sure to check the security of the application, then install it at your own risk. Some applications might adversely affect other applications or your entire cell phone. They may cause virus infection, damage various data, and send out your location information, usage history or personal information stored in your cell phone via the Internet.
- The Company assumes no responsibility for any problems that might be caused by applications you have installed. In such case, you may be charged a repair fee even during the warranty period.
- The Company assumes no responsibility for any disadvantage brought to you or any third party by applications you have installed.
- Some applications require that a microSD memory card be inserted.
- Some applications prohibit the product from entering sleep mode while they are active, or rapidly drain the battery while running in the background.
- Operation procedures and screen appearances of the applications preinstalled in the product and those installed by you are subject to change without notice as a result of version upgrade. Note that there may be differences with descriptions in this manual.

Setting the App Permissions

The first time you launch an app/function that accesses the functions or information of the product, a confirmation screen for requesting access permission appears. If a confirmation screen appears, confirm the content and tap [ALLOW]/[DENY].

- Depending on the app/function, [Allow all the time], [Allow only while using the app], etc. may appear.

Example: When 写真/動画 (Photos/Movies) is activated

1 Apps permission confirmation screen → [ALLOW] / [DENY]

Tap "ALLOW", allow the use of function normally. When you use multiple function, follow the same operations for each function.

Setting for Each App/Function

■ Setting for each app

- 1 Home screen → [Settings] → [More] → [Apps & notifications]
- 2 [SEE ALL XX APPS] → Select app → [Permissions] → Select function → [Allow] / [Deny]

■ Setting for each function

- 1 Home screen → [Settings] → [More] → [Apps & notifications]
- 2 [Permission manager] → Select function → Select app → [Allow] / [Deny]



memo

- If you do not permit, app/function may not be activated or use of function may be limited.
- For some apps/functions, an explanation screen for the permission appears. The confirmation screen may also appear multiple times, or the display may differ. Confirm the displayed content and follow the onscreen instructions.
- In this manual, description of confirmation screens may be omitted.

Cell Phone Etiquette

■ Use of Cell Phones is Not Allowed in the Following Places!

- Do not listen to music, watch videos while driving a car or motorbike, or riding a bicycle. Use of cell phones while driving a car or motorbike is prohibited by law. (Use of cell phones while riding a bicycle may also be punishable by law.) In addition, stay alert to the traffic around you even when walking. Surrounding sounds might not be heard clearly, and gazing at the screen may distract your attention causing a traffic accident. Be especially careful at railroad crossings, station platforms and pedestrian crossings.
- Since using the product on airplanes is restricted, follow the instructions given by the respective airlines.

■ Be Considerate of People around You

- Do not make calls in theaters, museums, libraries, and other similar places. Turn power off or turn on manner mode so as not to disturb others around you with your ringtones.
- In a city area, use in a place where you do not bother people walking.
- It is extremely dangerous to walk while looking at the screen of the cell phone. Do not suddenly stop to talk on/operate the cell phone or do so while walking.
- Move to a place where you do not disturb others while you are in shinkansen, a hotel lobby, etc.
- Be careful not to be loud while talking.
- Be careful of sound leakage from earphones in trains or other places with many people around you.
- Ask permission if you take photos with your cell phone camera.
- When using the camera, follow common rules of etiquette regarding camera use.
- There may be a person with a cardiac pacemaker nearby at a place filled with people such as in a crowded train. Turn on "Airplane mode" or turn the cell phone off in such places.
- When a medical institution has laid down designated areas where use of the product is prohibited or is not allowed to be brought in, abide by the instructions of that medical institution.

Getting Ready

Names and Functions of Parts

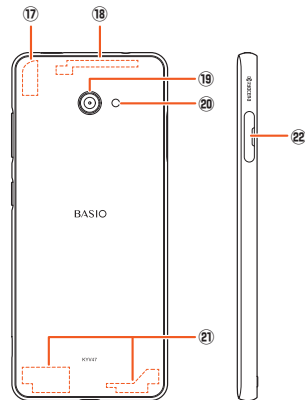
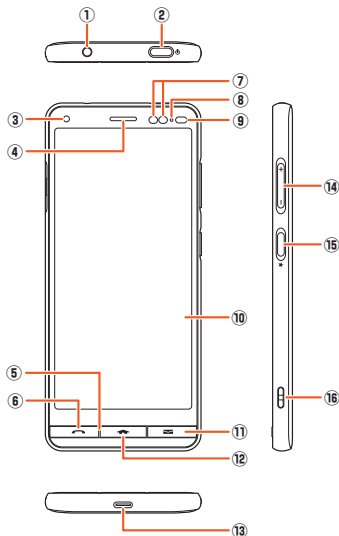

- ① Earphone microphone terminal**
Used for connecting earphones (commercially available) or other accessories.
- ②  Power button**
Power ON/OFF, activate/deactivate sleep mode, etc.
- ③ In camera (lens)**
- ④ Receiver/speaker**
Hear the other party's voice on call, play sound of answer memo, etc. with Dynamic Receiver. Also hear ringtones, alarm, etc.

⑤ Mouthpiece (microphone)

Relays your voice to the other party. Also use to record audio. Take care not to cover the microphone with your fingers during a call or recording a video.

⑥  Phone button

Make/receive calls. Flashes when there is a missed call.

⑦ Infrared port

Send/receive data by infrared communication.

⑧ Charging light

Lights red during charging.

⑨ Proximity sensor / Light sensor

The proximity sensor ensures that the touch panel does not accidentally respond.

Light sensor detects the ambient light level to adjust the display brightness.

⑩ Display (touch panel)**⑪  Mail button**

Use for sending and checking au-mail/+Message(SMS). Flashes to notify of received au-mail/+Message(SMS).

⑫  Home button

Return to the home screen.

⑬ External connection terminal

Use for connecting desktop holder, Type C Common AC Adapter 02 (sold separately), etc.

⑭  Volume up / down button

Adjusts sound volume.

⑮  Direct button

Press and hold for set function.



⑯ Strap eyelet**⑰ Built-in GPS/Wi-Fi®/Bluetooth® antenna*****⑱ Built-in sub-antenna*****⑲ Out camera (lens)****⑳ Photo light / Light****㉑ Built-in main antenna*****㉒ au IC card/microSD memory card tray**

* The antenna is built into the product. Covering the antenna with your hand might affect communication quality.

**memo**

- Ⓒ Do not put stickers, etc. on the proximity sensor/light sensor.
- Ⓒ The back cover of the product is not removable. Removing the back cover with force may cause damage or malfunction.
- Ⓒ The battery is built into the product and it is not removable. To force stop and reboot the product, refer to "Forcing the Product to Shut Down and Restart" (▶ P.53).









To make calls, display the home screen, and create mail more conveniently, the product has a  (Phone button),  (Home button), and  (Mail button) below the display.



: Activates the phone app.

: Displays the home screen.

: Displays the mail app selection screen.

-  flashes when a call is arriving and for missed calls. Press  while flashing to answer a call or check history.
-  flashes when au-mail or +Message(SMS) is received. Press  while flashing and tap "au-mail" / "+Message(SMS)" to check received mail.
- At time of purchase, you can press // to wake from sleep mode.



- , , and  can be made inoperable when the display is turned off to prevent erroneous operation.

au IC Card (SIM Card)

Your phone number etc. is recorded on the au IC card.

The product is compatible with au Nano IC Card 04.

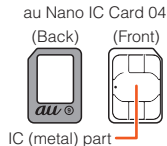

- Note that mishandling the au IC card might cause malfunction or damage, be careful not to do the followings.
 - Do not touch the IC (metal) part of the au IC card.
 - Check the correct insert direction.
 - Do not forcefully attach/remove the card.
- If the au IC card is not attached correctly or the au IC card has any abnormality, the error message is displayed.
- Do not lose the removed au IC card.
- Do not insert your au IC card with an conversion adapter attached. Doing so may cause malfunction.

■ When an IC Card is Not Inserted

When an IC Card is not inserted, the following operations are not available.

- Making*/Receiving a call
- Sending/Receiving +Message
- Initial settings and sending/receiving of au-mail
- PIN code setting
- Checking your phone number and e-mail address of the product

Besides the items above, functions that require your phone number may also be unavailable.

* Emergency calls such as 110 (Police), 119 (Fire/Ambulance), 118 (Maritime rescue) are also unavailable. However, only emergency calls may be available in overseas. (Emergency call numbers differ depending on the countries/regions.)

■ PIN Code Limit Settings

To protect your personal information, you can limit unauthorized use of the au IC card by a third party by changing PIN code or locking SIM card (▶ P.35 "PIN Code").

Attaching/Removing an IC Card

- Attach/Remove the au IC card after turning off the product.

Attaching an IC Card

- 1 With your fingertip on the groove in the au IC card/microSD memory card tray, pull it out without bending

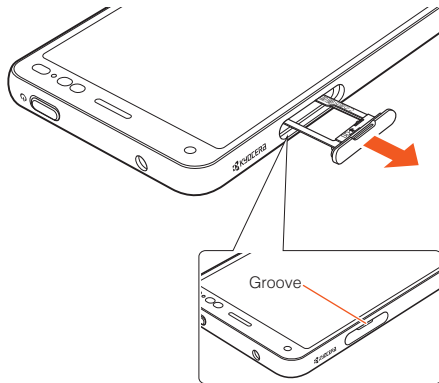

2 Hold the au IC card with its IC (metal) chip downward and insert in au IC card/microSD memory card tray

- Note location of notch.
- To avoid breaking the tab on the au IC card/microSD memory card tray, slide the au IC card in the direction shown to attach.
- Insert the au IC card in the au IC card/microSD memory card tray completely.

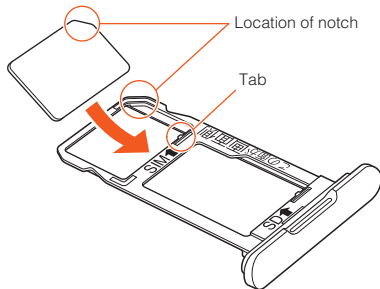

3 Insert the au IC card/microSD memory card tray in the product, and push in all the way without bending

- Ensure that the tray is not partially open (▶ P.28).

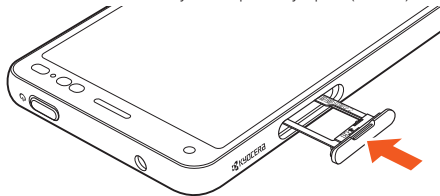

Removing au IC Card

- 1 With your fingertip on the groove in the au IC card/microSD memory card tray, pull it out without bending
- 2 Remove the au IC card from the au IC card/microSD memory card tray

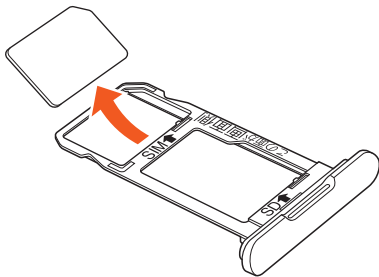

- 3 Insert the au IC card/microSD memory card tray in the product, and push in all the way without bending

Attaching/Removing microSD Memory Card

Turn the product off before attaching/removing the microSD memory card.

Attaching microSD Memory Card

- 1 With your fingertip on the groove in the au IC card/microSD memory card tray, pull it out without bending (► P.42)
- 2 Hold the microSD memory card with its terminal side (metal) downward and insert in au IC card/microSD memory card tray
 - To avoid breaking the tab on the au IC card/microSD memory card tray, slide the microSD memory card in the direction shown to attach.
 - Insert the microSD memory card in the au IC card/microSD memory card tray completely.

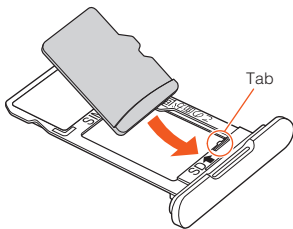

- 3** Insert the au IC card/microSD memory card tray in the product, and push in all the way without bending (▶ P.42)

memo

◎ The microSD memory card has a back and front side/top and bottom orientation. Trying to insert the card forcefully may cause the card to become permanently lodged or cause damage.

Removing microSD Memory Card

To prevent corruption (erasure) of data when removing a microSD memory card, always unmount a card with the following operation.

- 1** Home screen → [Settings] → [More] → [Storage] → "UNMOUNT" in "SD card"
- 2** With your fingertip on the groove in the au IC card/microSD memory card tray, pull it out without bending (▶ P.42)
- 3** Remove the microSD memory card from the au IC card/microSD memory card tray

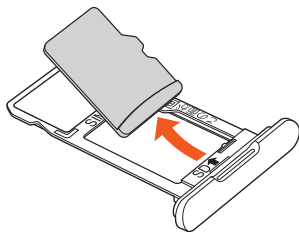

- 4** Insert the au IC card/microSD memory card tray in the product, and push in all the way without bending (▶ P.42)

 **memo**

- ⊙ Do not touch the terminal part of microSD memory card.
- ⊙ After using the product for a long time, the removed microSD memory card may become warm. This is not a malfunction.

Charging

The internal battery is not fully charged at the time of purchase. Charge the battery before using the product. When the red light turns into green, the charging will be completed.

 **memo**

- ⊙ The AC adapter and desktop holder are not water resistant. Never charge the product if it becomes wet.
- ⊙ The product may become warm while charging or during other operations, this is not abnormal.
- ⊙ When temperature of environment or the product is extremely high or low, charging may be stopped. Charge the battery at room temperature as much as possible.
- ⊙ Charging the product while using the camera function, the charging time may take longer than usual.
- ⊙ Doing various operations with the specified charger (sold separately) connected, the battery life may get short due to the short time charging/discharging.
- ⊙ Make sure the connection is correct if the charging light of the product blinks in red. If the charging light continues to blink, immediately stop charging, and contact an au shop or Repair and Delivery Support Center.
- ⊙ Keep a metal accessory or conductive materials (metal pieces, pencil lead, etc.) from coming in contact with the connection terminal and prevent them from getting inside.

Charging with the Specified AC Adapter

How to charge the product using Type C Common AC Adapter 02 (sold separately) is described here. For information on the specified AC adapter (sold separately), see "Related Accessories" (▶P. 75).

1 Connect the power plug of Type C Common AC Adapter 02 (sold separately) to an outlet (100V - 240V AC)

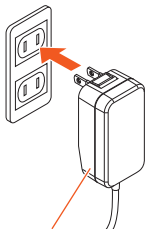

Type C Common AC Adapter 02
(sold separately)

2 Insert the USB Type-C plug of Type C Common AC Adapter 02 (sold separately) straight into the external connection terminal

The USB Type-C plug is reversible and can be inserted to the terminal which side is up. Make sure that the charging light turns into red. When the battery power turns on,  appears on the status bar. When charging is complete, the charging light turns into green.

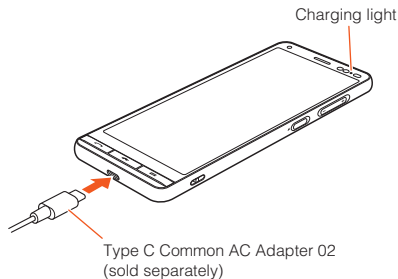

- 3** When charging is complete, pull out the USB Type-C plug of Type C Common AC Adapter 02 (sold separately) straight from the external connection terminal
- 4** Connect the power plug of Type C Common AC Adapter 02 (sold separately) to an outlet



memo

- Note that applying unnecessary force with an external device connected to the external connection terminal may cause damage.
- When the battery is charged in the case that the batteries run out, charging light may not turn to green soon, but charging is started.

Charging Using a Desktop Holder

How to charge the product using the supplied desktop holder connected with Type C Common AC Adapter 02 (sold separately) is described here. For information on specified charging equipment (sold separately), refer to "Related Accessories" (▶P.75).

- 1** Plug the USB Type-C plug of Type C Common AC Adapter 02 (sold separately) straight into the external device port on the desktop holder

The USB Type-C plug is reversible and can be inserted to the terminal which side is up. Insert it straight in the direction shown.

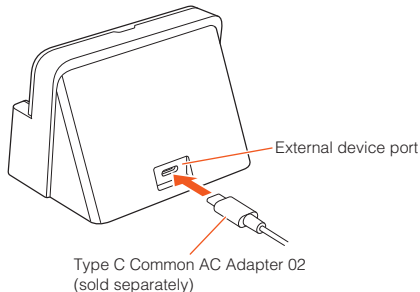

- 2** Connect the power plug of Type C Common AC Adapter 02 (sold separately) to an outlet (100V to 240V AC).

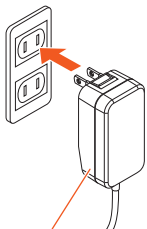

Type C Common AC Adapter 02
(sold separately)

- 3** With the product display facing you, hold the product with the external device port downward and insert all the way on the USB plug

Make sure that the charging light turns into red.
When charging is complete, the charging light turns into green.

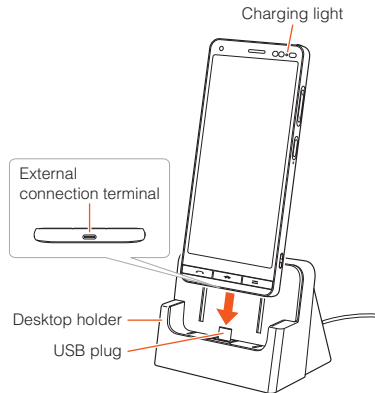

- 4 When charging is complete, remove the product from the desktop holder

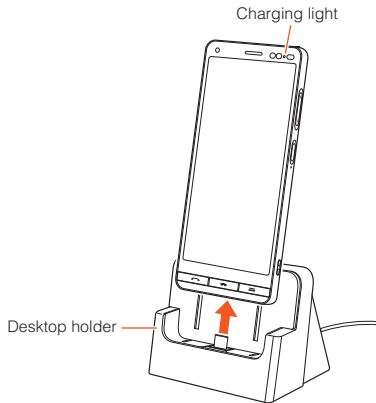

- 5 Remove the power plug of Type C Common AC Adapter 02 (sold separately) from the outlet

Cover Adapter

Removing the cover adapter allows you to charge in a desktop holder with a desktop holder-compatible device cover (commercially available) still attached. You can remove the cover adapter as shown below.

- If not using a device cover (commercially available), use the product with the cover adapter attached.

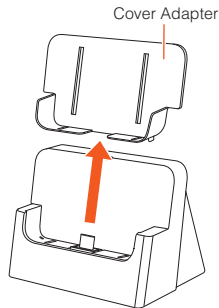

Using Dock Mode

Even in Silent mode, connecting the product to the supplied desktop holder causes it to temporarily exit Silent mode, and allows ringtones, etc. to sound.

- Requires connection to an outlet using a Common AC Adapter (sold separately).

Setting Dock Mode

1 Home screen → [Settings] → [More] → [Sound and vibrations] → [Dock Mode]

2 Turn [Use Dock Mode] "ON"

If "Use Dock Mode" is "ON" and the product is placed in the supplied desktop holder while in Silent mode, the product temporarily exits Silent mode, and a message is displayed indicating it is entering Dock mode.

Setting Ringtone for Dock Mode

Set whether Dock mode ringtone reads out a caller's name.

1 Home screen → [Settings] → [More] → [Sound and vibrations] → [Dock Mode]

2 [Dock Mode ringtone] → [Readout/Default setting]



memo

- ⦿ A caller's phone number is read out if they are not registered in Contacts.
- ⦿ Depending on display and call settings, names may not be read out.

Charging with a PC

How to charge the product connecting to USB port that supports PC charging with the USB Type-C cable (commercially available) is described here.

1 Connect the USB Type-C cable (commercially available) to the USB port of PC when the PC is completely activated.

2 Insert the USB Type-C plug of the USB Type-C cable (commercially available) straight into the external connection terminal

The USB Type-C plug is reversible and can be inserted to the terminal which side is up. Make sure that the charging light turns into red. When charging is complete, the charging light turns into green.

- If "USE USB FOR" is displayed on the product, select "Charge this device"/"DENY".
- When a screen such as new hardware search appears on PC, select "Cancel".

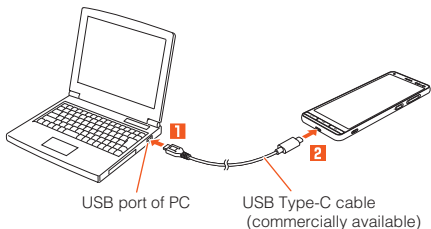

- 3 When charging is complete, remove the USB Type-C cable (commercially available) from the external connection terminal and PC.

memo

- When the battery is charged in the case that the batteries run out, charging light may not turn to green soon, but charging is started.
- The charging time may take longer than charging with a specified AC adapter. And the charging time also varies depending on your PC.

Turning the Power On/Off

Turning the Power On

- 1 Press and hold  (Power button) until the display turns on

The start screen appears (▶ P. 56).

- The first time you turn on the product, initial settings such as "au Initial Setting" activate. Make settings as required referring to "Making Initial Settings" (▶ P.53).

memo



- When logos are being displayed on the screen, do not touch the screen because the initial setting of the touch panel activates. Doing so may prevent the touch panel from working properly.
- You can skip completing "au Initial Setting" when first starting up the product and complete it later.

Turning the Power Off

- 1 Press and hold  (Power button) for at least 1 second
- 2 [Power off]

Forcing the Product to Shut Down and Restart

You can force the product to power off and reboot when the screen does not respond, or the power cannot be turned off.

- 1 Press and hold  (Power button) and  (Volume up key) for at least 11 seconds**



memo

- ◎ If you turn off the product forcibly and restart, an unsaved data will be lost. Do not perform except when the product does not respond.

Making Initial Settings

The first time you turn on the product after purchase, a screen for configuring initial settings appears. Follow the onscreen instructions to set functions.

- To skip any of the settings, tap "SKIP", "NEXT", etc., and follow the onscreen instructions.

- 1 Tap "日本語 (日本)" to select "English" → "United States" → [START]**
- 2 Set a Wi-Fi® network**
- 3 Configure the product**

You can copy your Google account, apps, and other settings from an Android terminal you already use.
- 4 Configure your Google account**
- 5 Confirm the details of Google services, etc**
- 6 Configure your smartphone protection**
- 7 Configure the Google assistant**
- 8 Configure Google Pay**
- 9 Configure other settings**
- 10 Configure "au Initial Setting" as required**

Setting an au ID

By setting an au ID, you can use various services provided by au such as "auかんたん決済" (au Simple Payment) which allows you to purchase applications available with au Smart Pass and Google Play.

1 Home screen → [Settings] → [More] → [au Settings Menu] → [au ID]

2 Follow the onscreen instructions to set an au ID

If you have already obtained an au ID, set the au ID you have.

If you do not have an au ID, register a new one. Follow the onscreen instructions.

Making Initial Settings for au-mail

au-mail is a service allowing you to exchange mail between your cell phone and a PC.

Before using au-mail, make initial settings for au-mail and obtain an au-mail address.

- Product operation and screen display is subject to change without notice.
- To make initial settings, disable (set OFF) the wireless LAN (Wi-Fi[®]) function (▶P.55).

1  → [au-mail]

2 [Agree] (two times) → [NEXT]

3 [ALLOW] (three times) → [OK]→[ALLOW]

4 [閉じる] (Close)

If a confirmation screen appears, follow the onscreen instructions.

Changing Your au-mail Address

1  → [au-mail] →  → [Change Address/Setting Filter] → [OK]→ [メールアドレスの変更へ] (Change mail address)

2 Enter the security code → [送信] (Send)

3 [承諾する] (Accept)

4 Enter characters in the editable portion of au-mail address (before @) → [送信] (Send) → [OK] → [閉じる] (Close)

- You can change the portion before "@" (up to 30 single-byte characters). Usable characters are single-byte alphanumeric (lowercase), "-" (hyphen), "." (dot), and "_" (underbar).

Using Wireless LAN (Wi-Fi®) Function

You can connect to a wireless LAN (Wi-Fi®) access point (router) in your home to use the Internet.

- An example is described where you enter a password to connect to an access point.

1 Home screen → [Settings] → [Wi-Fi]

2 Set [Use Wi-Fi] to "ON"

- The Wi-Fi screen is displayed, and nearby access points are displayed.

3 Tap the access point to connect to → Enter the password for the access point

4 [CONNECT]

- You connect to the access point (✔ is displayed at the top of the screen).



memo

- Password for the access point: check the router instructions, etc.
- Depending on your connection environment, connection speed may drop or you may not be able to use the connection.
- Depending on the access point, you may not be required to enter a password.

Switching to English Display

Switch the language displayed on the screen to English.

1 Home screen → [設定 (Settings)] → [その他 (More)] → [システム(System)] → [言語と入力 (Languages & input)] → [言語 (Languages)]

2 [English]

The message "起動中のアプリ、メール送受信、ダウンロードなどが終了される場合があります。" (Apps, mail transmission/reception, and downloads may be terminated.) appears, confirm the content and then tap [OK].

Start Screen

The start screen is displayed when you turn the product on or cancel the sleep mode.

Switching to the Home Screen from the Start Screen

You can switch to the home screen with the following operations when the start screen appears.

1 Slide the screen to the left

The home screen appears (▶P.59). Or, the previous screen which the product turns to sleep mode appears.



《Start Screen》

① Clock display

② Notifications

Displays notifications such as for missed calls.

- Double-tap a notification to activate notified app.

Sleep Mode

Press  (Power button) while the backlight is turned on or perform no operation for a certain period, the screen goes off temporarily and the product enters sleep mode. Doing the following operation, cancel the sleep mode.

1 In sleep mode, press (Power button)

The start screen appears (▶P.56).

memo

- To change the time to enter sleep mode, home screen → [Settings] → [More] → [Display] → [Screen timeout], and select the time.
- When you press  (Power button) to display the screen in sleep mode, do not touch the screen. Doing so may prevent the touch panel from working properly.

Basic Operations

Using Touch Panel

The product's display is a touch panel that can be used by touching directly.

- Operating the touch panel in the following ways may cause no response or misoperation.
 - With gloves on
 - With fingernails
 - With something placed on the screen
 - With films (commercially-available protective films or privacy protectors) or stickers on touch panel
 - With water droplets or condensation on the display
 - With wet or sweaty fingers
 - Under water

■ Tap/Double-tap

Lightly touch a screen and then immediately release your finger. Tapping a screen twice in the same position is called double-tap.

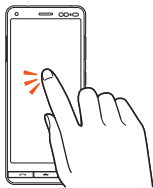

■ Long-touch

Keep touching an item.

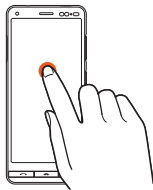

■ Slide/Swipe

When content is partially hidden, lightly touch the screen and slide in the desired direction.

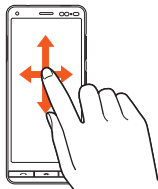

■ Flick

Touch the screen and flick up/down/left/right.

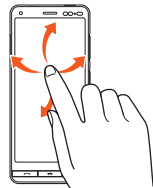

Zoom in/Zoom out

With two fingers on the screen, widen your fingers (zoom in) or close them (zoom out).

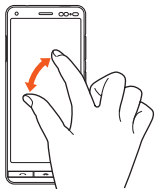

Drag

To move an item, icon, etc., lightly touch the screen and slide it to the desired position.

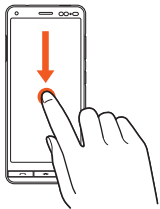

Using Touch Keys

The following touch keys are displayed at the bottom of the screen.

Display	Description
BACK	Returns to the previous screen.
CAPTURE	Saves an image of the currently displayed screen (screen shot). ▶ P.62 "Using Screen Memo"
RECENTS	Opens the recent apps screen.

Using the Home Screen

Home screen consists of several screens, and can be toggled by sliding/flicking left or right.

Press  to display the main home screen.

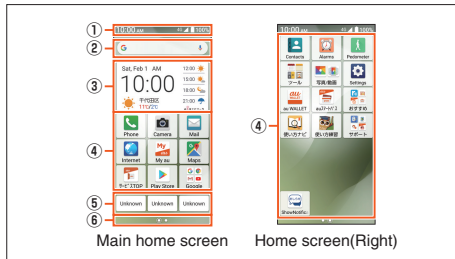

《Home screen (time of purchase)》

- ① **Status bar**
- ② **Search box**
- ③ **Time/weather**
- ④ **Applications/folders**
Icons/folders for pre-installed applications are displayed.
- ⑤ **One-touch buttons**
- ⑥ **Indicator**

memo

- ◎ In this manual, operations from the default home screen layout are explained.

Activating the Apps

Some functions activated by tapping app icons may incur communication charges.

1 Home screen → Tap an app/folder to activate

- If you tap a folder, tap an app to activate from the app list in the folder.

Monitoring the Product's Status

Viewing Icons

Notification icons for missed calls, new mail, and running operations are displayed on the left of the status bar, and status icons for product status are displayed on the right.









Main Notification Icon

Icon	Description
	Missed call
	New +Message/new SMS
	New mail message (au-mail)
	New mail message (Gmail)
	Emergency rapid mail
	A next alarm, snoozed alarm, or stopped (still set) alarm
	Notification of calendar
	radiko+FM playing
	During a call or receiving a call
	Answering memo
	Internal memory low
	File receiving request from other Bluetooth® device
	Send/upload data
	Receive/download data
	Installed completely

Icon	Description
	Notification of updating installed apps
	Software update
	USB tethering
	Bluetooth® tethering
	Tethered with two or more links
	Screenshot completed
	microSD memory card is mounted

Main Status Icon

Icon	Description
	Time
	Battery level
	100%/ empty/ charging
	Signal strength/Signal condition (LTE/WiMAX 2+) level 4/ out of range/ in communication 4G LTE/WiMAX 2+ available*/ roaming (Communication mode according to the network is also shown)
	Airplane mode is set
	Wi-Fi® signal strength level 4/ level 0
	Alarm setting
	Silent mode (Vibrate)
	Silent mode (Mute)
	Silent mode (Drive)

Icon	Description
	Connected to Bluetooth® device
	Wi-Fi® tethering
	Answering memo set
	Answering memo: set/  full
	VPN connection
	GPS in use
	Date saver set

* The 2 networks, "LTE" and "WiMAX 2+", are available in Japan. In any case of the screen display is "4G". The Company determines the network less congested to connect due to busy network conditions.

Notification Panel

In the notification panel, you can check notifications and activate apps. Also, frequently used functions can be set ON/OFF immediately.

1 Slide down the status bar

The notification panel is displayed.

Slide notification panel up or tap "NOTIFICATION" for details of missed calls, etc. You can tap the home screen → [ShowNotification] to check notification details.



memo

- To hide the notification panel, slide from the bottom of the screen to the top.
- To delete notifications, flick the notifications left/right. Tap "CLEAR ALL" to delete all notifications.

Setting Silent Mode

Set to the Silent mode so as not to disturb others around you in public places.

1 Press (volume up button) or (volume down button)

The Silent mode icon and volume adjustment bar are displayed.

2 Tap the Silent mode icon to change the Silent mode setting



Silent mode icon

Volume adjustment bar

Changing Silent Mode Type

- 1 Home screen → [Settings] → [Sound] → [CHANGE] in [Silent mode type]
- 2 [Vibrate] / [Mute] / [Drive]

Setting Airplane Mode

When Airplane mode is set to ON, wireless functions are disabled (telephone, data communication, wireless LAN (Wi-Fi®), Bluetooth®).

- 1 Home screen → [Settings] → [More] → [Network & internet] → Set [Airplane mode] to "ON"

When Airplane mode is set to ON,  appears in the status bar.

Checking Your Phone Number (Profile)

- 1 Home screen → [Settings] → [Profile]
The Profile screen appears.

Using Screen Memo

You can tap "CAPTURE" at the bottom of the screen to save an image (screen shot) of the currently displayed screen or view a saved image.

Capturing a Screen Memo

- 1 In a screen you want to capture, [CAPTURE]
- 2 [Save this screen]
The displayed screen is saved.
- 3 [Close]
 - Tap [View] to check the saved screen memo.
 - Tap [Send] to send the saved screen memo with email, etc.

Checking Screen Memos

- 1 Home screen → [写真/動画 (Photos/Movies)]
- 2 [Screen Memo] → Tap a screen memo
The screen memo is displayed.

 **memo**

- To delete a screen memo, display the screen memo and select [MENU] → [Delete] → [OK].

Displaying Menu

There are two types of methods to display a menu screen; by tapping "MENU", "☰" or "⋮" and by long-touching entry field or item.

Using the Direct Button

Press and hold the Direct button () to use an application you have preset. You can preset the following applications to the Direct button.

- au PAY
- Google assistant
- radiko+FM
- Camera

Setting the Direct Button

- 1** Home screen → [Settings] → [More] → [Direct button]
- 2** [Select Applications]

- Set [Wake device & application] to "ON" to enable the Direct button to be used even while the display is turned off.

3 Tap the application you want to set

- Tap "OFF" to not use the Direct button.

 **memo**

- At time of purchase, "au PAY" is set. "au PAY" allows code payment when only using a smartphone. For details, check the au homepage.

Using the One-touch button

Registering to the One-Touch Button

You can register people you call frequently to the (One-touch buttons) at the bottom of the home screen to make calling simple.

- Register numbers and mail addresses beforehand to Contacts.

- 1** Home screen → Tap an unregistered one-touch button
- 2** [OK] → Tap a person to register

Making a Call with the One-Touch Button

- 1 Tap a registered one-touch button in the home screen
- 2 [PHONE] → Talk
- 3  / [END CALL]

Sending Mail/+Message with the One-Touch Button

- 1 Tap a registered one-touch button in the home screen
- 2 [EMAIL] → [Gmail] / [au-mail]
- 3 [JUST ONCE] / [ALWAYS]
 - After selecting [ALWAYS], the selected email application is activated each time.
- 4 Enter subject / text and send
 - Sending +Message
 - 2 [SMS] → Enter text → [

Editing Registered One-Touch Buttons

- 1 Tap a registered One-Touch Button in the home screen → [MENU]
- 2 [Unregister] / [Change contact]



memo

- © Deleting a contact that is also registered to a One-Touch Button deregisters the One-Touch Button.

Telephone

Making a Call



1  → "DIALPAD" tab

The phone number input screen is displayed.

2 Enter a phone number

When calling to fixed-line phones, enter the area code first even if the recipient is in the same city.

3 [CALL] → Talk →  / [END CALL]

Press  (Volume up button)/ (Volume down button) during a call to adjust volume (other party's voice).



memo

- If you cover the screen by your face etc. while dialing/ calling, the display turns off for preventing false operation.
- Note that even if you cover the microphone, the sound can be conveyed to the other party.

Receiving a Call

1 Incoming call screen → 

The call starts.

2 Talk →  / [END CALL]

Making a Call from Contacts

1 Home screen → [Contacts] → tap the contact

2 [PHONE] → Talk →  / [END CALL]

Appendix

Updating Software

When a software update becomes required, the product obtains the latest software automatically and updates with it during night hours.

Software updates are available regularly to improve product quality after purchase with regard to performance, operation, and security to ensure problem-free use.

Notes on Software Update

- You are charged for data communication when connecting to the Internet from the product using data communication. Especially for OS update, large data communication occurs. You are recommended to use Wi-Fi®.
- When software update is necessary, you will be informed on au homepage, etc. For details, contact an au shop or Customer Center (call toll-free 157). In addition, users of the product will receive a notice from au, when software update is necessary to improve the functionality of the product.
- It is recommended to back up your data before updating software.

- If software update has failed or stopped, perform the same procedure again.
- Update may be unavailable during international roaming.
- If the software update fails, it may become impossible to operate the product. If this happens, bring it to an au shop or Toyota store dealing in au (not accepted by some shops).
- Any operations are not available during software update. Calling 110 (Police), 119 (Fire/Ambulance), 118 (Maritime rescue) and 157 (Customer Center) is not available. Alarm does not work, either.

Downloading Software into the Product to Update

You can check for and download the latest software at your convenience when an update becomes required with the following operation.

By not updating software, you have a greater risk of virus infection, and you do not have the benefit of functional improvements and trouble fixes. Always keep your software updated.

1 Home screen → [Settings] → [Software Update]

From here on, follow the onscreen instructions.



memo

- ◎ Network conditions may cause the product to switch from Wi-Fi® to mobile communication. Note that depending on the terms of your subscription contract, communication charges may be incurred for the product to automatically search for available networks.
- ◎ After a software/OS update, the product cannot revert to the previous version software.
- ◎ After software is updated, the product restarts. Note that any data that you were editing may become discarded.

Troubleshooting

Before you assume that the product is malfunctioning, confirm the following contents and perform "クイック診断 (Quick check)" and "トラブル診断 (Trouble check)" in "故障紛失サポート (Repair and Delivery Support)" app.

■ Quick check

Home screen → [サポート (Support)] → [故障紛失サポート (Repair and Delivery Support)] → [クイック診断してみる (Try quick check)] (Displayed language is Japanese only)



■ Trouble check

Home screen → [サポート (Support)] → [故障紛失サポート (Repair and Delivery Support)] → [便利な機能 (Useful functions)] → [トラブル診断を試す (Try trouble check)] (Displayed language is Japanese only)

Also available on the following au home page.

<https://www.au.com/trouble-check/>



Trouble	Detail	Page
Cannot turn on power	Is the internal battery charged?	P.46
	Is  (Power button) pressed and held until the screen turns on?	P.52
Cannot charge the product	Is the specified charger (sold separately) correctly used for charging?	P.47
	Is the product at a high or low temperature? The product may stop charging depending on a temperature.	—
	Is the specified accessory (adapter etc.) used for charging?	P.47
	Are the desktop holder or external device port soiled?	—
Cannot operate/ The screen does not respond/ Cannot turn off the power	Press and hold  (Power button) and  (Volume up key) at the same time for at least 11 seconds.	P.76
The power is turned off automatically	Is the internal battery adequately charged?	P.46
The power is turned off while the wake-up logo is displayed	Is the internal battery adequately charged?	P.46

Trouble	Detail	Page
Cannot make calls	Is the power turned on?	P.52
	Is the au IC card inserted?	P.42
	Was the number entered correctly? (Was the area code entered?)	P.65
	Did you tap "CALL" after entering the number?	P.65
Cannot receive calls	Is "Airplane mode" still set?	P.62
	Is the signal good enough?	P.60
	Is the product within the service area?	P.60
	Is the power turned on?	P.52
	Is the au IC card inserted?	P.42
	Is "Incoming Reject" still set?	—
 (out of service area) appears	Is "Airplane mode" still set?	P.62
	Is "Call forwarding services" still set?	—
	Is the product within the service area or where signal is good enough?	P.60
	Is the built-in antenna covered with finger, etc.?	P.39
	Is a card inserted other than the au IC card?	P.41

Trouble	Detail	Page
Cannot connect to Wi-Fi®	Is Wi-Fi® signal strong enough?	P.60
	Is Wi-Fi® setting completed?	—
	Is the product or the battery at a high temperature? The product may stop functioning if at a high/low temperature.	—
	Is "Airplane mode" still set?	P.62
Display /  (Power button) turns on but ringtone does not sound	Is the "Ringtone/Notification volume" set to the minimum?	—
	Is "Silent mode" set?	P.61
Cannot operate button/touch panel	Is the power turned on?	P.52
	Is the security setting for the start screen set?	—
	Turn off the power and then turn it on again.	P.52
Cannot operate the touch panel as intended	Check for the correct operation of the touch panel.	—
	Turn off the power and then turn it on again.	P.52
A message indicating that charging is necessary is displayed	The battery is almost empty.	P.46
The product answers calls when it shouldn't	Is "Auto answering" set?	—

Trouble	Detail	Page
The battery can only be used a short time	Is the battery adequately charged? • Charge until the red charging indicator turns green.	P.46
	Does the internal battery have adequate service life remaining?	P.23
	Is the product often used in a place where  (out of service area) appears?	P.60
When making a call, there is a busy signal and the call does not connect	Is the product within the service area or where signal is good enough?	P.60
	The wireless line is extremely busy or the party is calling. Retry later.	—
Display goes off shortly	Is the time period before entering "Screen timeout" set to short?	—
Display is dark	Is the "Brightness level" set to dark?	—
	Is the temperature of the product or battery high? The display may become dark depending on the temperature of the product.	—
Cannot hear/hard to hear the other party's voice	Is the call volume set to the minimum?	P.65
	Hold the receiver to your ear.	P.39
Cannot use microphone of earphone microphone	Is the connector inserted correctly? Insert all the way in earphone microphone terminal.	P.75

Trouble	Detail	Page
Operation speed decreased/apps operate unstably/cannot activate some apps	Operation becomes unstable when available memory is low. When available memory is low, delete unnecessary apps to secure free memory.	P.60
Settings made for specified contacts do not work	Is the caller ID notified? If the caller does not notify the caller ID, ringtone setting in Contacts is not effective. Group's incoming settings in Contacts is not effective, either.	—
	Are two or more same telephone number registered in the phone book?	—
microSD memory card cannot be recognized	Is the microSD memory card correctly inserted?	P.44
	Is the microSD memory card unmounted?	—
Camera does not operate	Is the product or the battery at a high temperature? The product may stop functioning if at a high/low temperature.	P.46
Cannot make an emergency call	Is the specified au IC card inserted?	P.42
	Is a card other than specified au IC card used?	—
	Is the product within the service area or where signal is good enough?	P.60

After-Sales Service

When Asking for Repair

For repair, contact Repair and Delivery Support Center.

During the warranty period	Repairs will be done based on the terms of services of the free-of-charge repair warranty.
Outside the warranty period	We shall repair the product for a charge as requested by the customer if repair renders it usable.

* The warranty period is one year from the day when you purchase the product.



- ⦿ Before handing the product for repair, make a backup of the contents of memory since they may disappear during repair. Note that the Company shall not be liable for any damages and loss of income should the contents of memory be altered or lost.
- ⦿ Recycled parts that meet the Company's quality standards are sometimes used for repair.
- ⦿ au portable terminals collected by Replacement cell phone delivery service which you used before are recycled to portable terminals for replacement after repairs. Also, parts replaced by au aftersales service are collected and recycled by the Company. They are not returned to customers.
- ⦿ For the products that are processed, modified, analyzed (including altering the software, analyzing (including rooting), reverse-engineering, decompiling, or disassembling), or repaired by repair offices other than the company specified, they are not covered by the warranty or repair may be refused.
- ⦿ The battery built into the product is not covered by the free-of-charge repair warranty except for events arising from defects in battery materials and manufacturing.
- ⦿ Accessories such as the desktop holder are not covered by the free-of-charge repair warranty.

Performance Parts for Repair

The Company retains performance parts for repair of the KYV47 main unit and its peripherals for 4 years after discontinuation of production. Performance parts for repair refers to parts required for maintaining the functions of the product.

Terms of Free-of-Charge Repair

1. When you apply for repair, inform us of your serial number (IMEI number). You can check the main unit or the sticker attached on the packaging box for the serial number (IMEI number).
2. Repairs will be done based on the terms of services of the free-of-charge repair warranty when the product is used correctly based on the instruction manual and the product is malfunctioning.
3. Repairs will be charged in the following cases even during the warranty period. (Also, the product cannot be repaired in some cases.)
 - ① When the product is not used correctly based on the instruction manual.
 - ② When the product is malfunctioning or damaged due to modification and repair.
 - ③ When the product is repaired by repair offices other than the company specified.
 - ④ When the product is malfunctioning or damaged due

to a handling fault or accident. Or when there are some traces that the product is damaged by falling, water or humidity.

- ⑤ When the product is malfunctioning or damaged due to earthquakes, storms, floods or other natural disasters, as well as fires, salt, abnormal voltage, etc.
4. Repairs may be refused depending on the damage condition of devices.
5. Note that the company shall not be liable for any damages and loss arising from the product malfunction.
6. The Company assumes no responsibility for any accidents when the product is connected with an unspecified device.
7. On-site repair is not available.
8. This warranty is valid only in Japan.

* The warranty guarantees that free-of-charge repairs will be done based on the terms of period and conditions indicated above. Therefore, the warranty does not limit your legal rights against persons in charge of the warranty and other operators.

Repair and Delivery Support

An after-sales service membership program on a monthly basis called "Repair and Delivery Support" is available for using your au portable terminal for a long time without worries. This service expands coverage for many troubles including malfunction, theft and loss.

For details of monthly fee and service, check on the au homepage.

<https://www.au.com/mobile/service/kosho-funshitsu/>
(in Japanese)



memo

- ◎ You can apply for membership only at the time of purchasing your au portable terminal.
- ◎ Once you cancel the membership, you cannot reapply for it until you purchase an au portable terminal next time.
- ◎ Note that when changing the model or purchasing an extra portable terminal, this service only covers the most recently purchased au portable terminal.
- ◎ When an au portable terminal is handed over to you or someone else, the "Repair and Delivery Support" membership is also handed over to the successor of the portable terminal.
- ◎ When you get a new au portable terminal by changing the model, purchasing an extra portable terminal, etc., the "Repair and Delivery Support" membership for the old au portable terminal is automatically canceled.
- ◎ Service contents are subject to change without notice.

au IC Card

The au IC card is lent to you by au. In case of loss or damage, the card will be replaced at your expense. When malfunction is suspected, or in case of theft or loss, contact an au shop or Toyota store dealing in au.

auスマートサポート (au Smart Support)

The Benefits of auスマートサポート (au Smart Support)

Telephone support from the au Smart Support center is available 24 hours, 365 days a year¹, and allows remote operation by support staff using the “遠隔操作サポート (Remote Support)” application.

And, you can enjoy other services and privileges that allow you to use your smartphone worry-free, such as “スマホ訪問サポート (Smartphone Visit Support) (requires additional fee)” where service staff can make a service visit² and explain in detail how to make initial settings, basic operation, and how to use popular applications, as well as a free gift “使い方ガイド本 (Usage Guide)”³, easy to understand even by those new to smartphones.

Subscription application required. For usage fee and other details, check on the au homepage (<https://www.au.com/>).

¹ Service between 10 pm and next-day 9 am requires reservation.

² Service visits limited to address given in your subscription contract.

³ Guide is a limited one-time gift.



memo

- ◎ When using “遠隔操作サポート (Remote Support)”, also refer to “Using 遠隔操作サポート (Remote Support)” (▶ P.73).

遠隔操作サポート (Remote Support)

When you inquire about smartphone operation, the operator is able to access your smartphone and view the same screen with you, and directly assist you with operation.

* Using this service requires subscription to any of auスマートサポート (au Smart Support), auスマートパス (au Smart Pass), auスマートパスプレミアム (au Smart Pass Premium), or 故障紛失サポート (Repair and Delivery Support).

Using 遠隔操作サポート (Remote Support)

1 Make an inquiry to Customer Center or the au Smart Support center

au Smart Pass members should call 157 (area code not required) (from an au phone/toll free) or ☎ 0077-7-111 (from a non-au phone or general subscriber phone/toll free).

auスマートサポート (au Smart Support) members should call the “専任チーム専用番号 (Dedicated Team Phone Number)” indicated on their membership card sent after subscribing to au Smart Support.

2 Home screen → [サポート (Support)] → [遠隔操作サポート (Remote Support)]

The first time you use this service, confirmation screens for permission and user license appear. Confirm the content and follow the onscreen instructions.

3 Follow the instructions of the operator

位置検索サポート (Location Search Support)

If your product is stolen or misplaced, it can be located and locked remotely from Customer Center or from your PC.

* Locating and locking your product remotely requires subscription to any of auスマートサポート (au Smart Support), auスマートパス (au Smart Pass), auスマートパスプレミアム (au Smart Pass Premium), or 故障紛失サポート (Repair and Delivery Support).



memo

- ◎ To use this service, set "My au" on with "Device admin apps". If not on, your product will not lock properly.
- ◎ If a confirmation screen for accessing location appears on the My au application, tap "Permit" to allow use of the function.

Using Location Search

In using location search, the Company assumes no responsibility for any damages resulting from location information as determined by Company-provided base stations or from GPS information, regardless of its cause.

Before Use

- If you have not permitted My au to access your product's location information, location search using GPS is not available.
- Even in a service area, it may not be possible to obtain accurate location where GPS and base station reception is poor, such as in an underground shopping area.

SIM Unlock

This product can be SIM-unlocked. SIM-unlocking the product allows other-carrier SIM cards to be used with it.

- Requests can be made for SIM-unlocking on the au homepage or at an au shop.
- When using non-au SIM card, some services, functions, etc. may be unavailable. The Company is not liable for any operations.
- For details, refer to au homepage. (Japanese)
<https://www.au.com/support/service/mobile/procedure/simcard/> (in Japanese)

Related Accessories

- Desktop holder (KYV47PUA)
- Type C Common AC Adapter 01 (0601PQA) (sold separately)
- Type C Common AC Adapter 02 (0602PQA) (sold separately)
- Micro-B to Type-C adapter (0601PHA) (sold separately)
- Common AC Adapter 04 White (0401PWA) (sold separately)*
- Common AC Adapter 05 (0501PWA) (sold separately)*
- テレビde写真 (Photos on TV) receiver (0603RKA) (sold separately)
- au Carrying Case G Black (0106FCA) (sold separately)

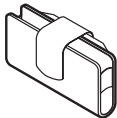

* Use requires a Micro-B to Type-C adapter (sold separately).



memo

- Accessories can be purchased from au online shop.
<https://onlineshop.au.com/> (in Japanese)

Using Earphones

You can use earphones, earphone microphone, and stereo earphone microphone (all commercially available).

- 1 Connect earphones to earphone microphone terminal (commercially available)

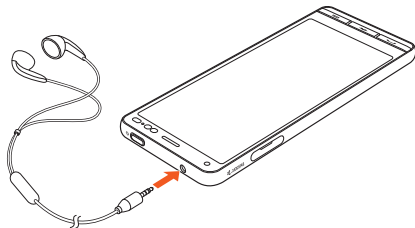

memo

- The earphones, earphone microphone, or stereo earphone microphone (commercially available) may not be usable depending on the type.

Main Specifications

■ Main Unit

Display	Approx. 5.6 inches, approx. 16.77 million colors, OLED	
	1,480 × 720 dots (HD+)	
Weight	Approx. 151g	
Dimensions (W × H × D)	Approx. 71 × 159 × 8.9mm	
Internal memory ^{*1}		ROM: Approx. 32 GB RAM: Approx. 3 GB
Continuous call time	In Japan	Approx. 1,480 minutes
	Overseas (GSM/UMTS/LTE)	Approx. 850 minutes
Continuous standby time	In Japan	Approx. 560 hours
	Overseas (GSM/UMTS/LTE)	Approx. 680 hours
Continuous tethering time	Approx. 780 minutes	
Maximum number of Wi-Fi tethering connection devices	10 devices	
Charging times (estimate)	Type C Common AC Adapter 02 (sold separately)	Approx. 180 minutes ^{*2}
Camera imaging element		CMOS
Effective out-camera pixels		Approx. 13 million pixels

Effective in-camera pixels		Approx. 5 million pixels
Wireless LAN (Wi-Fi [®]) function		IEEE802.11a/b/g/n/ac compatible
Bluetooth [®] function	Compatible version	Bluetooth [®] standards Ver.5.0 compatible ^{*3}
	Output	Bluetooth [®] standards Class 1
	Communication range ^{*4}	Within 10 m with no obstacles in the range
	Supported Bluetooth profile ^{*5}	GATT (Generic Attribute Profile) SPP (Serial Port Profile) A2DP (Advanced Audio Distribution Profile) AVRCP (Audio/Video Remote Control Profile) HSP (Headset Profile) HFP (Hands-Free Profile) OPP (Object Push Profile) PBAP (Phone Book Access Profile) HID (Human Interface Device Profile) PAN (Personal Area Networking Profile) PAN-NAP (Personal Area Networking-Network Access Point) PAN USER (Personal Area Networking-User) HOGP (HID over GATT Profile) apt-X Bluetooth SSP MAP (Message Access Profile) AAC LDAC DUN (Dial-Up Networking Profile) ^{*6}

Bluetooth® function	Frequency bands	2.4GHz band
------------------------	--------------------	-------------

- *1 Since the storage is shared by data and apps, storage space may be reduced depending on the usage of apps.
- *2 Charging time may be longer when used connected to the desktop holder.
- *3 It is confirmed that the product and all Bluetooth® devices are compliant with Bluetooth® standards designated by Bluetooth SIG, and they are authenticated. However, procedures may differ or data transfer may not be possible depending on the device's characteristics or specifications.
- *4 It changes according to objects obstructing devices and signal reception.
- *5 Specifications provided in Bluetooth® standards for making communication between Bluetooth®-compatible devices in accordance with their intended use.
- *6 Supported for some car navigation systems only. See the au homepage for usage.



memo

- ◎ The continuous talk time and continuous standby time may drop to less than half depending on the battery charging status, usage environment such as temperature, reception condition at the location where the product is used, and the function settings.

Specific Absorption Rate (SAR) of Cell Phones

This model EB1217 cell phone complies with Japanese technical regulations for exposure to radio waves and international guidelines on radio wave protection. This cell phone has been designed in observance of the Japanese technical regulations regarding exposure to radio waves⁽¹⁾ and limits to exposure to radio waves recommended by equivalent international guidelines. These international guidelines were set out by the International Commission on Non-Ionizing Radiation Protection (ICNIRP), which is in collaboration with the World Health Organization (WHO), and the permissible limits include a substantial safety margin designed to assure the safety of all persons, regardless of age and health condition.

The Japanese technical regulations and international guidelines define the limits using a unit of measurement known as the Specific Absorption Rate (SAR), which represents the average amount of radio frequency energy absorbed by the human body. The SAR limit for cell phones is 2.0 W/kg. The highest SAR value for this cell phone when tested for use at the ear is 1.683 W/kg⁽²⁾. The highest SAR value for this cell phone when tested for use on the body is 1.219 W/kg⁽²⁾. There may be slight differences in SAR levels among individual products, but they all satisfy the limit. The actual SAR of this cell phone while talking on the

phone can be well below that indicated above. This is due to automatic changes in the power level of the cell phone to ensure it only outputs the minimum power required to communicate with a base station. Therefore in general, the closer you are to a base station, the lower the power output of the cell phone is.

This cell phone can be used in positions other than against your head. Use a carrying case or similar accessory that holds the phone at least 1.5 cm separated from the body and ensure no metal parts are located between you and the cell phone. Under these conditions, this cell phone satisfies Japanese technical regulations and international guidelines for radio wave protection.

The World Health Organization has stated that "a large number of studies have been performed over the last two decades to assess whether mobile phones pose a potential health risk. To date, no adverse health effects have been established as being caused by mobile phone use". .

If you would like to know more detailed information, please refer to the WHO website.

<https://www.who.int/emf>

Please refer to the websites listed below if you would like to know more detailed information regarding SAR.

-
- Ministry of Internal Affairs and Communications website
<https://www.tele.soumu.go.jp/e/sys/ele/index.htm>
 - Association of Radio Industries and Businesses website
<https://www.arib-emf.org/01denpa/denpa02-02.html>
(in Japanese)
 - au homepage
<https://www.au.com/english/>
-

*1 Technical regulations are defined by the Ministerial Ordinance Related to Radio Law (Article 14-2 of Radio Equipment Regulations).

*2 This includes the wireless function that can be used simultaneously.

Federal Communication Commission Interference Statement

This device complies with part 15 of the FCC Rules. Operation is subject to the following two conditions: (1) This device may not cause harmful interference, and (2) this device must accept any interference received, including interference that may cause undesired operation.

This device has been tested and found to comply with the limits for a Class B digital device, pursuant to Part 15 of the FCC Rules. These limits are designed to provide reasonable protection against harmful interference in a residential installation. This equipment generates, uses, and can radiate radio frequency energy, and, if not installed and used in accordance with the instructions, may cause harmful interference to radio communications. However, there is no guarantee that interference will not occur in a particular installation. If this equipment does cause harmful interference to radio or television reception, which can be determined by turning the equipment off and on, the user is encouraged to try to correct the interference by one or more of the following measures:

- Reorient or relocate the receiving antenna.
- Increase the separation between the equipment and receiver.
- Connect the equipment into an outlet on a circuit different from that to which the receiver is connected.
- Consult the dealer or an experienced radio/TV technician for help.

FCC Caution:

- Any Changes or modifications not expressly approved by the party responsible for compliance could void the user's authority to operate the equipment.
- The antenna(s) used for this transmitter must not be co-located or operating in conjunction with any other antenna or transmitter.
- The country code selection is for non-US model only and is not available to all US model. Per FCC regulation, all WiFi product marketed in US must fixed to US operation channels only.

RF Exposure Information (SAR)

This device meets the government's requirements for exposure to radio waves.

This device is designed and manufactured not to exceed the emission limits for exposure to radio frequency (RF) energy set by the Federal Communications Commission of the U.S. Government.

The exposure standard for wireless device employs a unit of measurement known as the Specific Absorption Rate, or SAR. The SAR limit set by the FCC is 1.6W/kg. *Tests for SAR are conducted using standard operating positions accepted by the FCC with the device transmitting at its highest certified power level in all tested frequency bands. Although the SAR is determined at the highest certified power level, the actual SAR level of the device while operating can be well below the maximum value. This is because the device is designed to operate at multiple power levels so as to use only the power required to reach the network. In general, the closer you are to a wireless base station antenna, the lower the power output.

The highest SAR value for the model device as reported to the FCC when tested for use at the ear is 0.56 W/kg and when worn on the body, as described in this user guide, is 0.60 W/kg (Body-worn measurements differ among device models, depending upon available accessories and FCC requirements.)

While there may be differences between the SAR levels of various devices and at various positions, they all meet the government requirement.

The FCC has granted an Equipment Authorization for this model device with all reported SAR levels evaluated as in compliance with the FCC RF exposure guidelines. SAR information on this model device is on file with the FCC and can be found under the Display Grant section of www.fcc.gov/oet/ea/fccid after searching on FCC ID: JOYEB1217.

For body worn operation, this device has been tested and meets the FCC RF exposure guidelines for use with an accessory that contains no metal and be positioned a minimum of 1cm from the body. Use of other accessories may not ensure compliance with FCC RF exposure guidelines. If you do not use a body-worn accessory and are not holding the device at the ear, position the handset a minimum of 1cm from your body when the device is switched on.

Intellectual Property Rights

Trademarks

Company names and product names referred to in this manual are trademarks or registered trademarks of the respective companies.



Google and Google logo, Android and Android logo, Google Play and Google Play logo, Play Music and Play Music logo, Play Movies & TV and Play Movies & TV logo, Gmail and Gmail logo, Google Maps and Google Maps logo, Google Drive and Google Drive logo, Google Maps Navigation and Google Maps Navigation logo, Google Chrome and Google Chrome logo, Google Voice Search and Google Voice Search logo, YouTube and YouTube logo are trademarks or registered trademarks of Google, LLC

Microsoft[®], Windows[®] and Windows[®] 8.1/Windows[®] 10 are registered trademarks of Microsoft Corporation in the U.S.A. and other countries. The official name for Microsoft[®] Windows[®] is Microsoft[®] Windows[®] Operating System.

Microsoft[®], Microsoft[®] Excel[®], Microsoft[®] PowerPoint[®], Windows Media[®], and Exchange[®] are trademarks or registered

trademarks of Microsoft Corporation in the United States and other countries.

Microsoft® Word and Microsoft® Office are product names of Microsoft Corporation in the United States.

QR code is a registered trademark of DENSO WAVE INCORPORATED.

microSD, microSDHC and microSDXC logos are trademarks of SD-3C, LLC.

Bluetooth® and logo are registered trademarks owned by the Bluetooth SIG, Inc., and KYOCERA Corporation is licensed to use those trademarks.

WiMAX is a trademark of WiMAX Forum.

Wi-Fi®, WPA®, WPA2®, WPA3®, Wi-Fi CERTIFIED logo, and Wi-Fi Direct® are registered trademarks of Wi-Fi Alliance.

Facebook and Facebook logo are trademarks or registered trademarks of Facebook, Inc.

Twitter and Twitter logo are trademarks or registered trademarks of Twitter, Inc., and are used under license.

Instagram is a trademark of Instagram, LLC in the U.S. and other countries.

iWnn of OMRON SOFTWARE Co., Ltd. is used for conversion methods for Japanese language, and for phrase prediction methods for English.

iWnn IME©OMRON SOFTWARE Co., Ltd. 2009-2019 All Rights Reserved.

THIS PRODUCT IS LICENSED UNDER THE MPEG-4 VISUAL PATENT PORTFOLIO LICENSE FOR THE PERSONAL AND NON-COMMERCIAL USE OF A CONSUMER FOR (i) ENCODING VIDEO

IN COMPLIANCE WITH THE MPEG-4 VISUAL STANDARD ("MPEG-4 VIDEO") AND/OR (ii) DECODING MPEG-4 VIDEO THAT WAS ENCODED BY A CONSUMER ENGAGED IN A PERSONAL AND NONCOMMERCIAL ACTIVITY AND/OR WAS OBTAINED FROM A VIDEO PROVIDER LICENSED BY MPEG LA TO PROVIDE MPEG-4 VIDEO. NO LICENSE IS GRANTED OR SHALL BE IMPLIED FOR ANY OTHER USE. ADDITIONAL INFORMATION INCLUDING THAT RELATING TO PROMOTIONAL, INTERNAL AND COMMERCIAL USES AND LICENSING MAY BE OBTAINED FROM MPEG LA, LLC. SEE [HTTP://WWW.MPEGLA.COM](http://www.MPEGLA.COM).

- (1) ACCESS, the ACCESS logo, and NetFront are registered trademarks or trademarks of ACCESS CO., LTD. in the United States, Japan and/or other countries.
- (2) This software is based in part on the work of the Independent JPEG Group.

"Dock mode" is a registered trademark of KYOCERA Corporation.

"もじチェン" by LIM Corporation LTD. is used for switching font. "もじチェン" is a registered trademark of LIM Corporation LTD. The product contains fonts provided by LIM Corporation LTD. The product contains fonts provided by Morisawa Inc.

BASIO is a registered trademark or trademark of KDDI.

The product is equipped with DeepCore® 3.0 Plus for Android by E-Globaledge Corporation as infrared communication function. Copyright © 2012 E-Globaledge Corp. All Rights Reserved.

"PhotoSolid", the function to avoid blurring still images, is a product of Morpho, Inc. "PhotoSolid" is a registered trademark of Morpho, Inc.

Morpho HDR is adopted for HDR (High Dynamic Range) technology. "Morpho HDR" is a trademark of Morpho, Inc.

USB Type-C™ is a trademark of USB Implementers Forum.

Amazon, Amazon.co.jp, and Amazon.co.jp logo are trademarks or registered trademarks of Amazon.com, Inc. or its affiliates.

All other company names and product names are trademarks or registered trademarks of respective companies.

License

OpenSSL License

【OpenSSL License】

Copyright © 1998-2011 The OpenSSL Project. All rights reserved.

This product includes software developed by the OpenSSL Project for use in the OpenSSL Toolkit. (<http://www.openssl.org/>)

THIS SOFTWARE IS PROVIDED BY THE OpenSSL PROJECT "AS IS" AND ANY EXPRESSED OR IMPLIED WARRANTIES, INCLUDING, BUT NOT LIMITED TO, THE IMPLIED WARRANTIES OF MERCHANTABILITY AND FITNESS FOR A PARTICULAR PURPOSE ARE DISCLAIMED. IN NO EVENT SHALL THE OpenSSL PROJECT OR ITS CONTRIBUTORS BE LIABLE FOR ANY DIRECT, INDIRECT, INCIDENTAL, SPECIAL, EXEMPLARY, OR CONSEQUENTIAL DAMAGES (INCLUDING, BUT NOT LIMITED TO, PROCUREMENT OF SUBSTITUTE GOODS OR SERVICES;

LOSS OF USE, DATA, OR PROFITS; OR BUSINESS INTERRUPTION) HOWEVER CAUSED AND ON ANY THEORY OF LIABILITY, WHETHER IN CONTRACT, STRICT LIABILITY, OR TORT (INCLUDING NEGLIGENCE OR OTHERWISE) ARISING IN ANY WAY OUT OF THE USE OF THIS SOFTWARE, EVEN IF ADVISED OF THE POSSIBILITY OF SUCH DAMAGE.

【Original SSLeay License】

Copyright © 1995-1998 Eric Young (eay@cryptsoft.com) All rights reserved.

This product includes cryptographic software written by Eric Young (eay@cryptsoft.com)

THIS SOFTWARE IS PROVIDED BY ERIC YOUNG "AS IS" AND ANY EXPRESS OR IMPLIED WARRANTIES, INCLUDING, BUT NOT LIMITED TO, THE IMPLIED WARRANTIES OF MERCHANTABILITY AND FITNESS FOR A PARTICULAR PURPOSE ARE DISCLAIMED. IN NO EVENT SHALL THE AUTHOR OR CONTRIBUTORS BE LIABLE FOR ANY DIRECT, INDIRECT, INCIDENTAL, SPECIAL, EXEMPLARY, OR CONSEQUENTIAL DAMAGES (INCLUDING, BUT NOT LIMITED TO, PROCUREMENT OF SUBSTITUTE GOODS OR SERVICES; LOSS OF USE, DATA, OR PROFITS; OR BUSINESS INTERRUPTION)

HOWEVER CAUSED AND ON ANY THEORY OF LIABILITY, WHETHER IN CONTRACT, STRICT LIABILITY, OR TORT (INCLUDING NEGLIGENCE OR OTHERWISE) ARISING IN ANY WAY OUT OF THE USE OF THIS SOFTWARE, EVEN IF ADVISED OF THE POSSIBILITY OF SUCH DAMAGE.

Users of the product are authorized to use software installed into the product described in this instruction manual. Pay attention to the following points when using the software.

- (a) The software installed on this product or part of it may not be altered, delivered, modified, analyzed, reverse-engineered, derived, and any such actions are prohibited.
- (b) Illegally importing the software or a part of it is prohibited.

- (c) This Software is provided without implied warranties of merchantability, fitness for a particular purpose and noninfringement of third party rights.

Note that the existing license agreement takes priority for usage of GNU General Public License (GPL), GNU Library/Lesser General Public License (LGPL) included in software, software based on other open source software license and software that KYOCERA Corporation is licensed.

For information on the Open source software, refer to "Open Source Software" as follows;

■ Open Source Software

Note that the existing license agreement takes priority for usage of GNU General Public License (GPL), GNU Library/Lesser General Public License (LGPL) included in software, software based on other open source software license and software that KYOCERA Corporation is licensed. The exact terms of GPL, LGPL and some other licenses are reproduced in "About phone" in this product. For details, refer to KYOCERA homepage.

This product includes software copyrighted by KYOCERA Corporation and licensed software.

Copyright of the software designed and developed complying with the open source software standard belongs to KYOCERA Corporation or the third parties, distribution, reproduction, transformation and transmission over public lines without consent of KYOCERA Corporation are prohibited, unless you are authorized or permitted by Copyright Law.

■ Recording Diagnosis and Usage Condition Data

KYOCERA Corporation asks for users' cooperation in order to improve the quality of products and services. KYOCERA Corporation records and saves data of failure diagnosis and the usage conditions (application usage by users, log related to error, detail information of application usage by users (specified functions, usage frequency, memory/battery status)) in the product in order to track and cope with diagnosis events such as unexpected shutdown or system error for the purpose of improvement of quality and services. Those information may be collected upon repair request by user after obtaining the user agreement.

For inquiries, call:

Customer Center

For general information (toll free)

Business hours 9:00 to 20:00 (7 days a week)

From au mobile phones: | From non-au mobile phones /
general subscriber phones:

157 area code not required |  0077-7-111

In case above numbers are not available (for free),

 0120-977-033 (except Okinawa)

 0120-977-699 (Okinawa)

In case of theft, loss, or malfunction (toll free)

Business hours 24-hour (7 days a week)

From au mobile phones: | From non-au mobile phones /
general subscriber phones:

113 area code not required |  0077-7-113

In case above numbers are not available (for free),

 0120-925-314

Repair and Delivery Support Center

For theft, loss, or malfunction (toll free)

Business hours 9:00 to 20:00 (7 days a week)

From au mobile phones / non-au mobile phones /
general subscriber phones:

 0120-925-919



やめましょう、
歩きスマホ。



あぶない!
電池への衝撃



キケン!
水ぬれ充電



モバイルリサイクルネットワーク
携帯電話・PHSのリサイクルにご協力。

Cell phone and PHS operators collect and recycle unused telephones, batteries and battery chargers at stores bearing the  logo regardless of brand and manufacturer to protect the environment and reuse valuable resources.

February 2020, 1st Edition

Sales: KDDI CORPORATION • OKINAWA CELLULAR TELEPHONE COMPANY

Manufactured by: KYOCERA Corporation