



FCC TEST REPORT

REPORT NO.: RF970128A02

MODEL NO.: S605

RECEIVED: Feb. 14, 2008

TESTED: Feb. 14 ~ March 31, 2008

ISSUED: April 3, 2008

APPLICANT: Motorola, Inc.

ADDRESS: Mobile Devices 600 N. U.S. Highway 45
Libertyville, IL 60048-5343 United States

ISSUED BY: Advance Data Technology Corporation

LAB LOCATION: No. 47, 14th Ling, Chia Pau Tsuen, Lin Kou Hsiang
244, Taipei Hsien, Taiwan, R.O.C.

This test report consists of 77 pages in total. It may be duplicated completely for legal use with the approval of the applicant. It should not be reproduced except in full, without the written approval of our laboratory. The client should not use it to claim product endorsement by TAF, A2LA or any government agencies. The test results in the report only apply to the tested sample.





TABLE OF CONTENTS

1.	CERTIFICATION	4
2.	SUMMARY OF TEST RESULTS	5
2.1	MEASUREMENT UNCERTAINTY	6
3.	GENERAL INFORMATION	7
3.1	GENERAL DESCRIPTION OF EUT	7
3.2	DESCRIPTION OF TEST MODES	8
3.2.1	CONFIGURATION OF SYSTEM UNDER TEST	9
3.2.2	TEST MODE APPLICABILITY AND TESTED CHANNEL DETAIL	11
3.2.3	GENERAL DESCRIPTION OF APPLIED STANDARDS	13
3.2.4	DESCRIPTION OF SUPPORT UNITS	13
4.	TEST TYPES AND RESULTS	14
4.1	CONDUCTED EMISSION MEASUREMENT	14
4.1.1	LIMITS OF CONDUCTED EMISSION MEASUREMENT	14
4.1.2	TEST INSTRUMENTS	14
4.1.3	TEST PROCEDURES	15
4.1.4	DEVIATION FROM TEST STANDARD	15
4.1.5	TEST SETUP	15
4.1.6	EUT OPERATING CONDITIONS	16
4.1.7	TEST RESULTS (1)	17
4.1.7	TEST RESULTS (2)	19
4.2	RADIATED EMISSION MEASUREMENT	21
4.2.1	LIMITS OF RADIATED EMISSION MEASUREMENT	21
4.2.2	TEST INSTRUMENTS	22
4.2.3	TEST PROCEDURES	23
4.2.4	DEVIATION FROM TEST STANDARD	23
4.2.5	TEST SETUP	24
4.2.6	EUT OPERATING CONDITIONS	25
4.2.7	TEST RESULTS	26
4.3	NUMBER OF HOPPING FREQUENCY USED	36
4.3.1	LIMIT OF HOPPING FREQUENCY USED	36
4.3.2	TEST INSTRUMENTS	36
4.3.3	TEST PROCEDURES	36
4.3.4	DEVIATION FROM TEST STANDARD	37
4.3.5	TEST SETUP	37
4.3.6	TEST RESULTS	37
4.4	DWELL TIME ON EACH CHANNEL	40
4.4.1	LIMIT OF DWELL TIME USED	40
4.4.2	TEST INSTRUMENTS	40
4.4.3	TEST PROCEDURES	40
4.4.4	DEVIATION FROM TEST STANDARD	40
4.4.5	TEST SETUP	41
4.4.6	TEST RESULTS	41
4.5	CHANNEL BANDWIDTH	49
4.5.1	LIMITS OF CHANNEL BANDWIDTH	49



4.5.2	TEST INSTRUMENTS	49
4.5.3	TEST PROCEDURE	49
4.5.4	DEVIATION FROM TEST STANDARD	50
4.5.5	TEST SETUP	50
4.5.6	EUT OPERATING CONDITION	50
4.5.7	TEST RESULTS	51
4.6	HOPPING CHANNEL SEPARATION	55
4.6.1	LIMIT OF HOPPING CHANNEL SEPARATION	55
4.6.2	TEST INSTRUMENTS	55
4.6.3	TEST PROCEDURES	55
4.6.4	DEVIATION FROM TEST STANDARD	56
4.6.5	TEST SETUP	56
4.6.6	TEST RESULTS	56
4.7	MAXIMUM PEAK OUTPUT POWER	61
4.7.1	LIMITS OF MAXIMUM PEAK OUTPUT POWER MEASUREMENT	61
4.7.2	TEST INSTRUMENTS	61
4.7.3	TEST PROCEDURES	61
4.7.4	DEVIATION FROM TEST STANDARD	61
4.7.5	TEST SETUP	62
4.7.6	EUT OPERATING CONDITION	62
4.7.7	TEST RESULTS	62
4.8	BAND EDGES MEASUREMENT	67
4.8.1	LIMITS OF BAND EDGES MEASUREMENT	67
4.8.2	TEST INSTRUMENTS	67
4.8.3	TEST PROCEDURE	67
4.8.4	DEVIATION FROM TEST STANDARD	67
4.8.5	EUT OPERATING CONDITION	67
4.8.6	TEST RESULTS	68
4.9	ANTENNA REQUIREMENT	74
4.9.1	STANDARD APPLICABLE	74
4.9.2	ANTENNA CONNECTED CONSTRUCTION	74
5.	PHOTOGRAPHS OF THE TEST CONFIGURATION	75
6.	INFORMATION ON THE TESTING LABORATORIES	76
7.	APPENDIX A – MODIFICATIONS RECORDERS FOR ENGINEERING CHANGES TO THE EUT BY THE LAB	77



1. CERTIFICATION

PRODUCT: Bluetooth Stereo Headset
BRAND NAME: MOTOROLA
MODEL NO.: S605
APPLICANT: Motorola, Inc.
TESTED: Feb. 14 ~ March 31, 2008
TEST SAMPLE: ENGINEERING SAMPLE
STANDARDS: FCC Part 15, Subpart C (Section 15.247),
ANSI C63.4-2003

The above equipment has been tested by **Advance Data Technology Corporation**, and found compliance with the requirement of the above standards. The test record, data evaluation & Equipment Under Test (EUT) configurations represented herein are true and accurate accounts of the measurements of the sample's EMC characteristics under the conditions specified in this report.

PREPARED BY : Celia Chen , **DATE:** April 3, 2008
(Celia Chen / Specialist)

TECHNICAL ACCEPTANCE : Jamison Chan , **DATE:** April 3, 2008
Responsible for RF (Jamison Chan / Senior Engineer)

APPROVED BY : Ken Liu , **DATE:** April 3, 2008
(Ken Liu / Deputy Manager)

2. SUMMARY OF TEST RESULTS

The EUT has been tested according to the following specifications:

APPLIED STANDARD: FCC Part 15, Subpart C			
STANDARD SECTION	TEST TYPE AND LIMIT	RESULT	REMARK
15.207	AC Power Conducted Emission	PASS	Meet the requirement of limit. Minimum passing margin is -10.12dB at 0.150MHz.
15.247(a)(1)(iii)	Number of Hopping Frequency Used Spec.: At least 15 channels	PASS	Meet the requirement of limit.
15.247(a)(1)(iii)	Dwell Time on Each Channel Spec. : Max. 0.4 second within 31.6 second	PASS	Meet the requirement of limit.
15.247(a)(1)	1. Hopping Channel Separation Spec. : Min. 25 kHz or 20 dB bandwidth, whichever is greater (see Note) 2. Spectrum Bandwidth of a Frequency Hopping Sequence Spread Spectrum System	PASS	Meet the requirement of limit.
15.247(b)	Maximum Peak Output Power Spec.: max. 21dBm (see Note)	PASS	Meet the requirement of limit.
15.247(d)	Transmitter Radiated Emissions Spec.: Table 15.209	PASS	Meet the requirement of limit. Minimum passing margin is -3.46dB at 2483.500MHz.
15.247(d)	Band Edge Measurement	PASS	Meet the requirement of limit.

NOTE: If The Frequency Hopping System operating in 2400-2483.5MHz band and the output power less than 125mW. The hopping channel carrier frequencies separated by a minimum of 25kHz or two-thirds of the 20dB bandwidth of hopping channel whichever is greater.

2.1 MEASUREMENT UNCERTAINTY

Where relevant, the following measurement uncertainty levels have been estimated for tests performed on the EUT as specified in CISPR 16-4-2:

This uncertainty represents an expanded uncertainty expressed at approximately the 95% confidence level using a coverage factor of $k=2$.

MEASUREMENT	FREQUENCY	UNCERTAINTY
Conducted emissions	9kHz ~ 30MHz	2.44 dB
Radiated emissions	30MHz ~ 1GHz	3.72 dB
	1GHz ~ 40GHz	2.89 dB

3. GENERAL INFORMATION

3.1 GENERAL DESCRIPTION OF EUT

PRODUCT	Bluetooth Stereo Headset
MODEL NO.	S605
FCC ID	IHDT6JN1
POWER SUPPLY	3.7Vdc from battery, 5Vdc from adapter, car charger or host equipment
MODULATION TYPE	GFSK, $\pi/4$ -DQPSK, 8DPSK
RADIO TECHNOLOGY	FHSS
TRANSFER RATE	1/2/3Mbps
OPERATING FREQUENCY	2400 ~ 2483.5MHz
NUMBER OF CHANNEL	79
OUTPUT POWER	3.112 mW
ANTENNA TYPE	Chip antenna with 3.32dBi gain
I/O PORTS	N/A
DATA CABLE	USB cable (1m) Earphone cable (0.8m)
ASSOCIATED DEVICES	Refer to note 2 below

NOTE:

1. The EUT is a wireless headset, with Bluetooth technology.
2. The EUT was power supplied from the following power adapter, car charger (for charging mode only) and battery:

Item	Brand	Model No.	Rating
Adapter	MOTOROLA	FMP5334A (Part No.: SPN5334A)	AC I/P: 100-240V, 0.15A, 50/60Hz DC O/P: 5.0V, 550mA Non-shielded DC (1.8m), AC 2-pin
Car charger	MOTOROLA	SYN1830A	DC I/P: 12V DC O/P: 4.75-5.25V Non-shielded DC (1.8m)
Battery	-	-	3.7Vdc

※ The EUT could not transmit or receive under charging mode.

3. The above EUT information was declared by the manufacturer and for more detailed features description, please refer to the manufacturer's specifications or User's Manual.

3.2 DESCRIPTION OF TEST MODES

79 channels are provided to this EUT:

CHANNEL	FREQ. (MHz)	CHANNEL	FREQ. (MHz)	CHANNEL	FREQ. (MHz)	CHANNEL	FREQ. (MHz)
0	2402	20	2422	40	2442	60	2462
1	2403	21	2423	41	2443	61	2463
2	2404	22	2424	42	2444	62	2464
3	2405	23	2425	43	2445	63	2465
4	2406	24	2426	44	2446	64	2466
5	2407	25	2427	45	2447	65	2467
6	2408	26	2428	46	2448	66	2468
7	2409	27	2429	47	2449	67	2469
8	2410	28	2430	48	2450	68	2470
9	2411	29	2431	49	2451	69	2471
10	2412	30	2432	50	2452	70	2472
11	2413	31	2433	51	2453	71	2473
12	2414	32	2434	52	2454	72	2474
13	2415	33	2435	53	2455	73	2475
14	2416	34	2436	54	2456	74	2476
15	2417	35	2437	55	2457	75	2477
16	2418	36	2438	56	2458	76	2478
17	2419	37	2439	57	2459	77	2479
18	2420	38	2440	58	2460	78	2480
19	2421	39	2441	59	2461		

3.2.1 CONFIGURATION OF SYSTEM UNDER TEST

FOR MODE A:

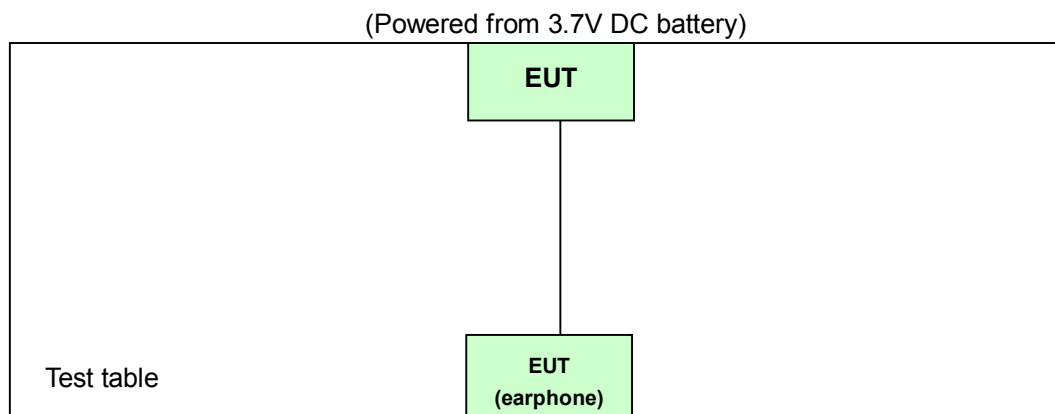

FOR MODE B (charging mode):

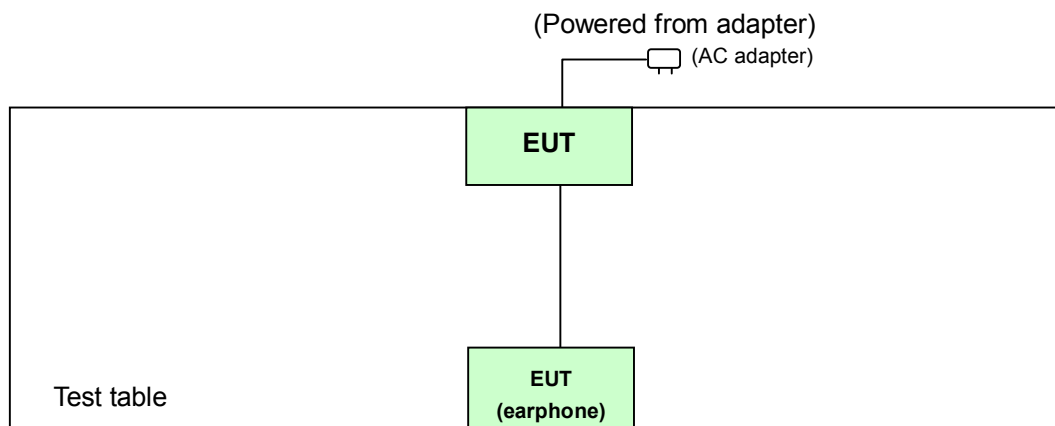

FOR MODE C (charging mode):

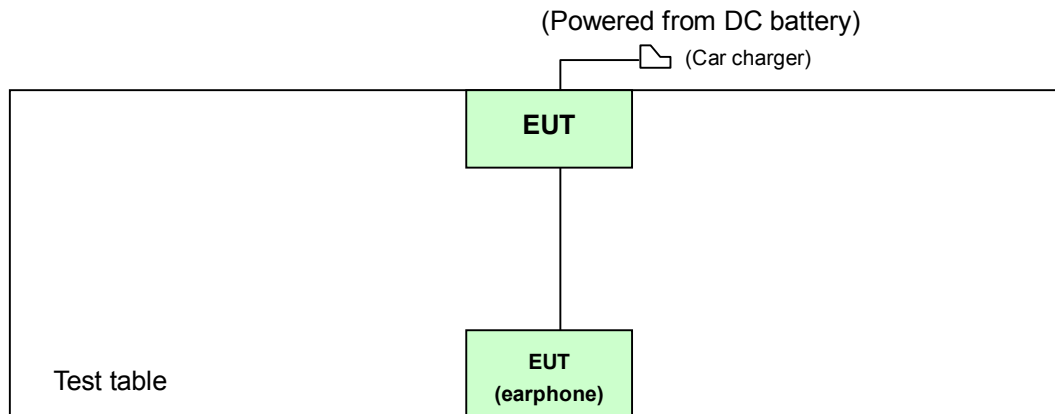

FOR MODE D (charging mode):

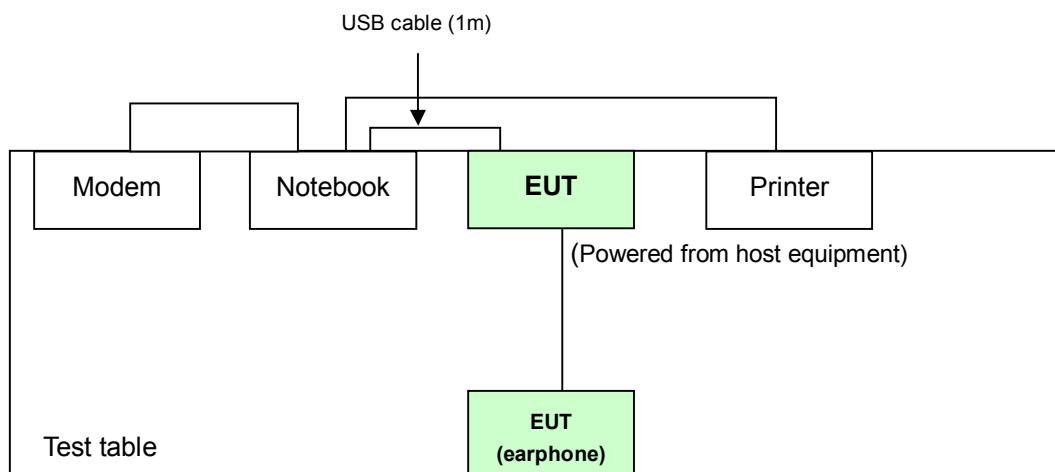

3.2.2 TEST MODE APPLICABILITY AND TESTED CHANNEL DETAIL

EUT CONFIGURE MODE	Applicable to				Description
	PLC	RE<1G	RE≥1G	APCM	
A	Note	√	√	√	Operating Mode (EUT only)
B	√	√	-	-	Charging Mode (EUT with adapter)
C	Note	√	-	-	Charging Mode (EUT with car charger)
D	√	√	-	-	Charging Mode (EUT with Notebook)

Where **PLC**: Power Line Conducted Emission **RE<1G**: Radiated Emission below 1GHz
RE≥1G: Radiated Emission above 1GHz **APCM**: Antenna Port Conducted Measurement
NOTE: No need to concern of Conducted Emission due to the EUT is powered by battery.

POWER LINE CONDUCTED EMISSION TEST:

- Pre-Scan has been conducted to determine the worst-case mode from all possible combinations between available modulations and packet types.
- Following channel(s) was (were) selected for the final test as listed below.

EUT CONFIGURE MODE	AVAILABLE CHANNEL	TESTED CHANNEL	MODULATION TECHNOLOGY	MODULATION TYPE	PACKET TYPE	DATE RATE
B	-	-	-	-	-	-
D	-	-	-	-	-	-

RADIATED EMISSION TEST (BELOW 1 GHz):

- Pre-Scan has been conducted to determine the worst-case mode from all possible combinations between available modulations, data rates, packet types data rate, XYZ axis and antenna ports (if EUT with antenna diversity architecture).
- Following channel(s) was (were) selected for the final test as listed below.

EUT CONFIGURE MODE	AVAILABLE CHANNEL	TESTED CHANNEL	MODULATION TECHNOLOGY	MODULATION TYPE	PACKET TYPE	DATE RATE	AXIS
A	0 to 78	78	FHSS	GFSK	DH5	1	Y
B	-	-	-	-	-	-	-
C	-	-	-	-	-	-	-
D	-	-	-	-	-	-	-

RADIATED EMISSION TEST (ABOVE 1 GHz):

- Pre-Scan has been conducted to determine the worst-case mode from all possible combinations between available modulations, data rates, packet types data rate, XYZ axis and antenna ports (if EUT with antenna diversity architecture).
- Following channel(s) was (were) selected for the final test as listed below.

EUT CONFIGURE MODE	AVAILABLE CHANNEL	TESTED CHANNEL	MODULATION TECHNOLOGY	MODULATION TYPE	PACKET TYPE	DATE RATE	AXIS
A	0 to 78	0, 39, 78	FHSS	GFSK	DH5	1	Y
A	0 to 78	0, 39, 78	FHSS	8DPSK	DH5	3	Y

BANDEDGE MEASUREMENT:

- Pre-Scan has been conducted to determine the worst-case mode from all possible combinations between available modulations and packet types of the antenna and antenna ports (if EUT with antenna diversity architecture).
- Following channel(s) was (were) selected for the final test as listed below.

EUT CONFIGURE MODE	AVAILABLE CHANNEL	TESTED CHANNEL	MODULATION TECHNOLOGY	MODULATION TYPE	PACKET TYPE	DATE RATE
A	0 to 78	0, 78	FHSS	GFSK	DH5	1
A	0 to 78	0, 78	FHSS	8DPSK	DH5	3

ANTENNA PORT CONDUCTED MEASUREMENT:

- Pre-Scan has been conducted to determine the worst-case mode from all possible combinations between available modulations and packet types of the antenna and antenna ports (if EUT with antenna diversity architecture).
- Following channel(s) was (were) selected for the final test as listed below.

EUT CONFIGURE MODE	AVAILABLE CHANNEL	TESTED CHANNEL	MODULATION TECHNOLOGY	MODULATION TYPE	PACKET TYPE	DATE RATE
A	0 to 78	0, 39, 78	FHSS	GFSK	DH5	1
A	0 to 78	0, 39, 78	FHSS	8DPSK	DH5	3



3.2.3 GENERAL DESCRIPTION OF APPLIED STANDARDS

The EUT is a RF Product. According to the specifications of the manufacturer, it must comply with the requirements of the following standards:

FCC Part 15, Subpart C. (15.247)

ANSI C63.4- 2003

All test items have been performed and recorded as per the above standards.

3.2.4 DESCRIPTION OF SUPPORT UNITS

The EUT has been tested as an independent unit together with other necessary accessories or support units. The following support units or accessories were used to form a representative test configuration during the tests.

NO.	PRODUCT	BRAND	MODEL NO.	SERIAL NO.	FCC ID
1	NOTEBOOK COMPUTER	DELL	PP05L	20375526736	FCC DoC Approved
2	PRINTER	EPSON	LQ-300+	DCGY017054	FCC DoC Approved
3	MODEM	ACEEX	1414	980020520	IFAXDM1414
4	BATTERY	GLOBAL	N/A	N/A	N/A

NO.	SIGNAL CABLE DESCRIPTION OF THE ABOVE SUPPORT UNITS
1	N/A
2	1.8m braid shielded wire, terminated with DB25 and Centronics connector via metallic frame, w/o core
3	1.2 m braid shielded wire, terminated with DB25 and DB9 connector via metallic frame, w/o core.
4	N/A

NOTE: All power cords of the above support units are non shielded (1.8m).

4. TEST TYPES AND RESULTS

4.1 CONDUCTED EMISSION MEASUREMENT

4.1.1 LIMITS OF CONDUCTED EMISSION MEASUREMENT

FREQUENCY OF EMISSION (MHz)	CONDUCTED LIMIT (dB μ V)	
	Quasi-peak	Average
0.15 ~ 0.5	66 to 56	56 to 46
0.5 ~ 5	56	46
5 ~ 30	60	50

- NOTE:**
1. The lower limit shall apply at the transition frequencies.
 2. The limit decreases in line with the logarithm of the frequency in the range of 0.15 to 0.50 MHz.
 3. All emanations from a class A/B digital device or system, including any network of conductors and apparatus connected thereto, shall not exceed the level of field strengths specified above.

4.1.2 TEST INSTRUMENTS

DESCRIPTION & MANUFACTURER	MODEL NO.	SERIAL NO.	CALIBRATED UNTIL
ROHDE & SCHWARZ Test Receiver	ESCS 30	838251/021	Dec. 19, 2008
ROHDE & SCHWARZ Artificial Mains Network (for EUT)	ESH3-Z5	100218	Nov. 20, 2008
LISN With Adapter (for EUT)	AD10	C10Ada-001	Nov. 21, 2008
ROHDE & SCHWARZ Artificial Mains Network (for peripherals)	ESH3-Z5	100219	Nov. 08, 2008
ROHDE & SCHWARZ Artificial Mains Network (for peripherals)	ESH3-Z5	894785/020	Jun. 27, 2008
Software	ADT_Cond_V7.3.5	NA	NA
Software	ADT_ISN_V7.3.5	NA	NA
RF cable (JYEBAO)	5D-FB	Cable-C10.01	Feb. 26, 2009
SUHNER Terminator (For ROHDE & SCHWARZ LISN)	65BNC-5001	E1-010773	Feb. 13, 2009

- NOTE:**
1. The calibration interval of the above test instruments is 12 months and the calibrations are traceable to NML/ROC and NIST/USA.
 2. The test was performed in ADT Shielded Room No. 10.
 3. The VCCI Site Registration No. C-1852.

4.1.3 TEST PROCEDURES

- a. The EUT was placed 0.4 meters from the conducting wall of the shielded room with EUT being connected to the power mains through a line impedance stabilization network (LISN). Other support units were connected to the power mains through another LISN. The two LISNs provide 50 ohm/ 50uH of coupling impedance for the measuring instrument.
- b. Both lines of the power mains connected to the EUT were checked for maximum conducted interference.
- c. The frequency range from 150kHz to 30MHz was searched. Emission levels under (Limit - 20dB) were not recorded.

4.1.4 DEVIATION FROM TEST STANDARD

No deviation

4.1.5 TEST SETUP

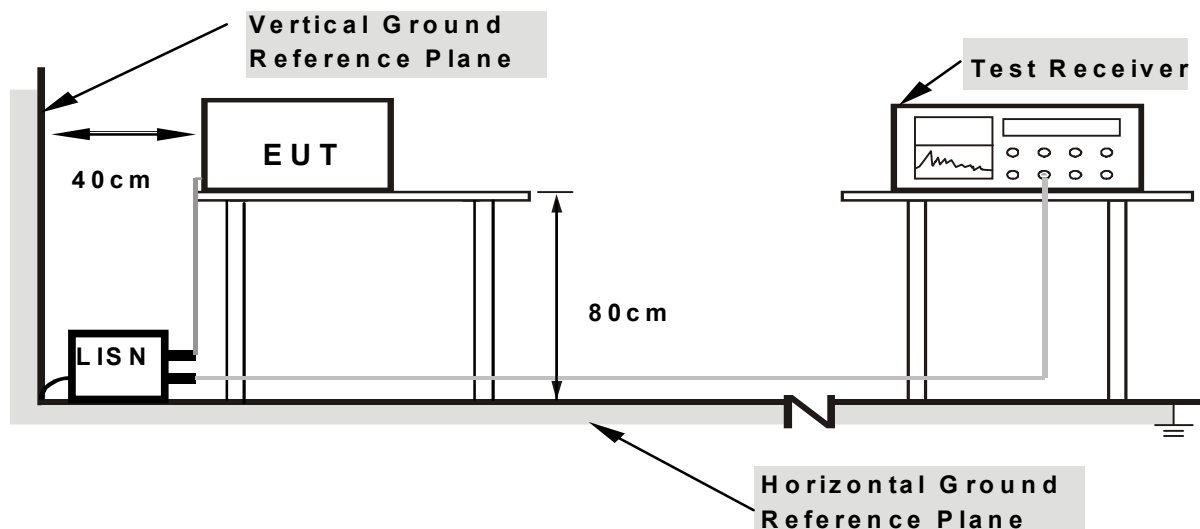

- Note:**
1. Support units were connected to second LISN.
 2. Both of LISNs (AMN) are 80 cm from EUT and at least 80 cm from other units and other metal planes support units.

For the actual test configuration, please refer to the related item – Photographs of the Test Configuration.

4.1.6 EUT OPERATING CONDITIONS

For Mode B:

- a. Connected the EUT with AC adapter placed on testing table.
- b. Set the EUT under charging condition
- c. Steps b-c were repeated.

For Mode D:

- a. Connected the EUT to Notebook via USB cable.
- b. Turned on the power of all equipment.
- c. Notebook ran a test program to enable all functions.
- d. Notebook read and wrote messages from HDD.
- e. Notebook sent "H" messages to its screen and monitor displays "H" patterns on the screen.
- f. Notebook sent messages to printer, and then printer printed them out.
- g. Notebook sent messages to modem.
- h. Set the EUT under charging condition
- i. Steps e-i were repeated.

4.1.7 TEST RESULTS (1)

TEST MODE	Mode B		
INPUT POWER	120Vac, 60 Hz	6dB BANDWIDTH	9 kHz
ENVIRONMENTAL CONDITIONS	20deg. C, 60% RH, 1002hPa	PHASE	Line 1
TESTED BY	Chad Lee		

No	Freq. [MHz]	Corr. Factor (dB)	Reading Value		Emission Level		Limit		Margin	
			[dB (uV)]		[dB (uV)]		[dB (uV)]		(dB)	
			Q.P.	AV.	Q.P.	AV.	Q.P.	AV.	Q.P.	AV.
1	0.150	0.17	43.23	-	43.40	-	66.00	56.00	-22.60	-
2	0.369	0.23	27.17	-	27.40	-	58.53	48.53	-31.13	-
3	1.297	0.26	24.99	-	25.25	-	56.00	46.00	-30.75	-
4	2.113	0.28	26.94	-	27.22	-	56.00	46.00	-28.78	-
5	2.734	0.31	29.11	-	29.42	-	56.00	46.00	-26.58	-
6	5.496	0.46	33.30	-	33.76	-	60.00	50.00	-26.24	-

- REMARKS:**
1. Q.P. and AV. are abbreviations of quasi-peak and average individually.
 2. "-": The Quasi-peak reading value also meets average limit and measurement with the average detector is unnecessary.
 3. The emission levels of other frequencies were very low against the limit.
 4. Margin value = Emission level - Limit value
 5. Correction factor = Insertion loss + Cable loss
 6. Emission Level = Correction Factor + Reading Value.



TEST MODE	Mode B		
INPUT POWER	120Vac, 60 Hz	6dB BANDWIDTH	9 kHz
ENVIRONMENTAL CONDITIONS	20deg. C, 60% RH, 1002hPa	PHASE	Line 2
TESTED BY	Chad Lee		

No	Freq. [MHz]	Corr. Factor (dB)	Reading Value		Emission Level		Limit		Margin	
			[dB (uV)]		[dB (uV)]		[dB (uV)]		(dB)	
			Q.P.	AV.	Q.P.	AV.	Q.P.	AV.	Q.P.	AV.
1	0.150	0.16	43.50	-	43.66	-	66.00	56.00	-22.34	-
2	0.447	0.22	24.99	-	25.21	-	56.93	46.93	-31.72	-
3	0.521	0.22	24.03	-	24.25	-	56.00	46.00	-31.75	-
4	2.152	0.28	20.59	-	20.87	-	56.00	46.00	-35.13	-
5	2.734	0.30	22.29	-	22.59	-	56.00	46.00	-33.41	-
6	5.672	0.43	25.08	-	25.51	-	60.00	50.00	-34.49	-

- REMARKS:**
1. Q.P. and AV. are abbreviations of quasi-peak and average individually.
 2. "-": The Quasi-peak reading value also meets average limit and measurement with the average detector is unnecessary.
 3. The emission levels of other frequencies were very low against the limit.
 4. Margin value = Emission level - Limit value
 5. Correction factor = Insertion loss + Cable loss
 6. Emission Level = Correction Factor + Reading Value.

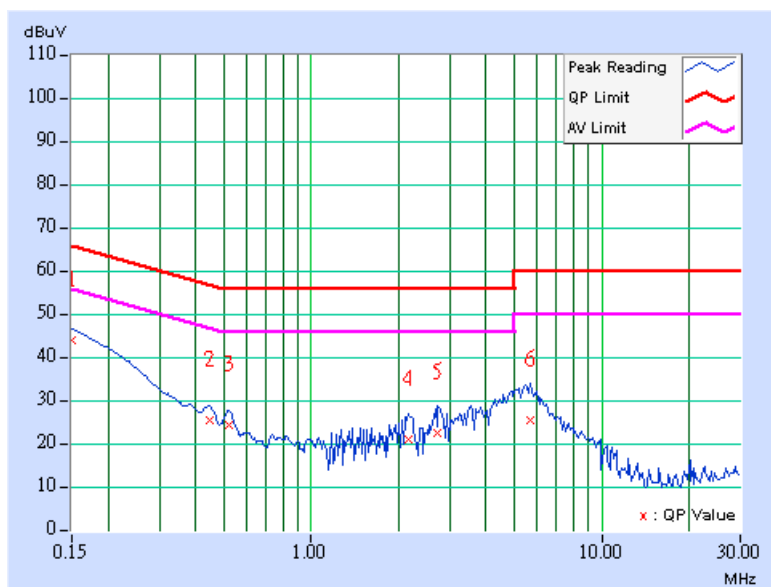

4.1.7 TEST RESULTS (2)

TEST MODE	Mode D		
INPUT POWER (SYSTEM)	120Vac, 60 Hz	6dB BANDWIDTH	9 kHz
ENVIRONMENTAL CONDITIONS	20deg. C, 60% RH, 1002hPa	PHASE	Line 1
TESTED BY	Chad Lee		

No	Freq. [MHz]	Corr. Factor (dB)	Reading Value		Emission Level		Limit		Margin	
			[dB (uV)]		[dB (uV)]		[dB (uV)]		(dB)	
			Q.P.	AV.	Q.P.	AV.	Q.P.	AV.	Q.P.	AV.
1	0.150	0.17	55.71	-	55.88	-	66.00	56.00	-10.12	-
2	0.177	0.20	49.51	-	49.71	-	64.61	54.61	-14.90	-
3	0.205	0.22	49.27	-	49.49	-	63.42	53.42	-13.93	-
4	0.310	0.23	41.39	-	41.62	-	59.97	49.97	-18.35	-
5	0.431	0.23	38.51	-	38.74	-	57.23	47.23	-18.49	-
6	0.627	0.24	41.67	-	41.91	-	56.00	46.00	-14.09	-
7	0.861	0.25	39.37	-	39.62	-	56.00	46.00	-16.38	-
8	0.998	0.25	39.75	-	40.00	-	56.00	46.00	-16.00	-

- REMARKS:**
1. Q.P. and AV. are abbreviations of quasi-peak and average individually.
 2. "-": The Quasi-peak reading value also meets average limit and measurement with the average detector is unnecessary.
 3. The emission levels of other frequencies were very low against the limit.
 4. Margin value = Emission level - Limit value
 5. Correction factor = Insertion loss + Cable loss
 6. Emission Level = Correction Factor + Reading Value.

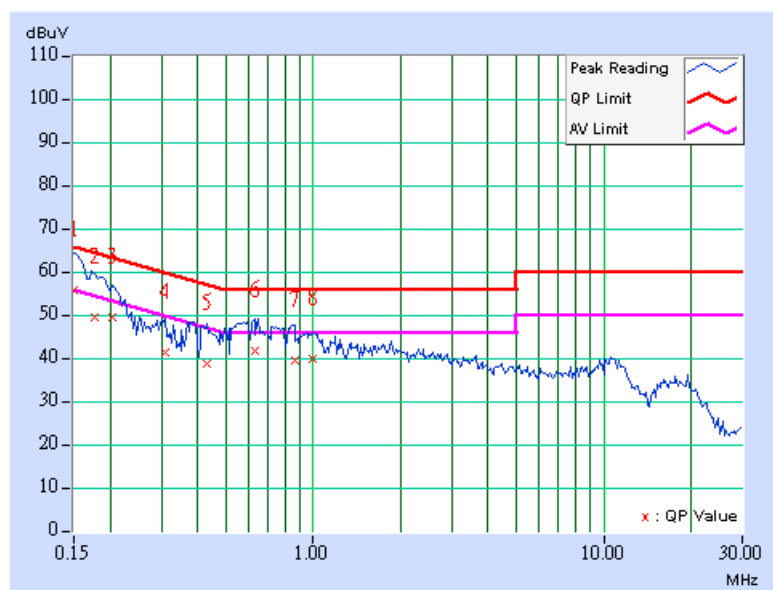

TEST MODE	Mode D		
INPUT POWER (SYSTEM)	120Vac, 60 Hz	6dB BANDWIDTH	9 kHz
ENVIRONMENTAL CONDITIONS	20deg. C, 60% RH, 1002hPa	PHASE	Line 2
TESTED BY	Chad Lee		

No	Freq. [MHz]	Corr. Factor (dB)	Reading Value		Emission Level		Limit		Margin	
			[dB (uV)]		[dB (uV)]		[dB (uV)]		(dB)	
			Q.P.	AV.	Q.P.	AV.	Q.P.	AV.	Q.P.	AV.
1	0.162	0.18	49.75	-	49.93	-	65.38	55.38	-15.45	-
2	0.185	0.20	52.13	-	52.33	-	64.25	54.25	-11.92	-
3	0.220	0.22	47.88	-	48.10	-	62.81	52.81	-14.71	-
4	0.345	0.22	36.59	-	36.81	-	59.07	49.07	-22.26	-
5	0.447	0.22	44.75	-	44.97	-	56.93	46.93	-11.96	-
6	0.576	0.23	45.46	-	45.69	-	56.00	46.00	-10.31	-
7	0.673	0.23	44.45	-	44.68	-	56.00	46.00	-11.32	-
8	0.888	0.24	43.12	-	43.36	-	56.00	46.00	-12.64	-
9	1.230	0.25	41.43	-	41.68	-	56.00	46.00	-14.32	-

- REMARKS:**
1. Q.P. and AV. are abbreviations of quasi-peak and average individually.
 2. "-": The Quasi-peak reading value also meets average limit and measurement with the average detector is unnecessary.
 3. The emission levels of other frequencies were very low against the limit.
 4. Margin value = Emission level - Limit value
 5. Correction factor = Insertion loss + Cable loss
 6. Emission Level = Correction Factor + Reading Value.

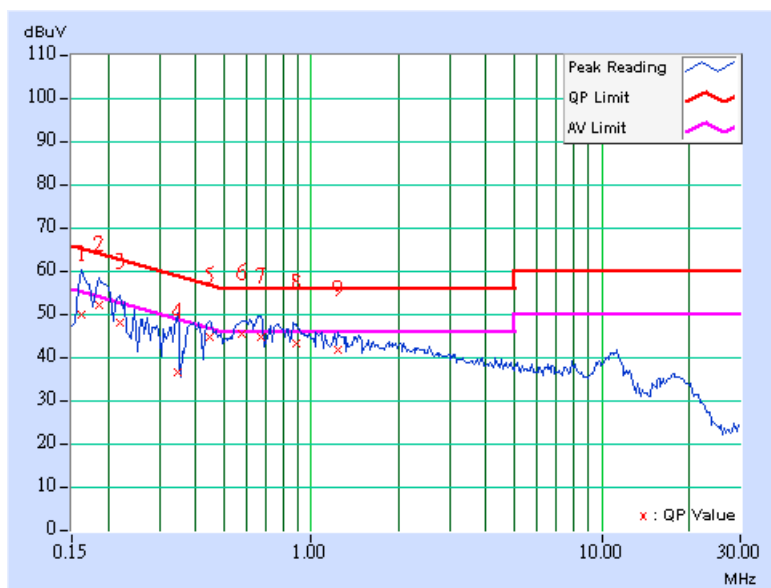

4.2 RADIATED EMISSION MEASUREMENT

4.2.1 LIMITS OF RADIATED EMISSION MEASUREMENT

Emissions radiated outside of the specified bands, shall be according to the general radiated limits in 15.209 as following:

FREQUENCIES (MHz)	FIELD STRENGTH (microvolts/meter)	MEASUREMENT DISTANCE (meters)
0.009 ~ 0.490	2400/F(kHz)	300
0.490 ~ 1.705	24000/F(kHz)	30
1.705 ~ 30.0	30	30
30 ~ 88	100	3
88 ~ 216	150	3
216 ~ 960	200	3
Above 960	500	3

NOTE:

1. The lower limit shall apply at the transition frequencies.
2. Emission level (dBuV/m) = 20 log Emission level (uV/m).
3. As shown in 15.35(b), for frequencies above 1000MHz, the field strength limits are based on average detector, however, the peak field strength of any emission shall not exceed the maximum permitted average limits, specified above by more than 20dB under any condition of modulation.



4.2.2 TEST INSTRUMENTS

DESCRIPTION & MANUFACTURER	MODEL NO.	SERIAL NO.	CALIBRATED UNTIL
HP Preamplifier	8447D	2432A03504	May 09, 2008
HP Preamplifier	8449B	3008A01201	Oct. 01, 2008
HP Preamplifier	8449B	3008A01292	Aug. 05, 2008
ROHDE & SCHWARZ TEST RECEIVER	ESI7	836697/012	Dec. 05, 2008
Schwarzbeck Antenna	VULB 9168	137	Sep. 13, 2008
Schwarzbeck Antenna	VHBA 9123	480	Apr. 18, 2008
EMCO Horn Antenna	3115	6714	Oct. 18, 2008
EMCO Horn Antenna	3115	9312-4192	Apr. 19, 2008
ADT. Turn Table	TT100	0306	NA
ADT. Tower	AT100	0306	NA
Software	ADT_Radiated_V7.6.15	NA	NA
SUHNER RF cable	SF104-26.5	CABLE-CH6-17m-01	Nov. 04, 2008
ROHDE & SCHWARZ Spectrum Analyzer	FSP 40	100035	Mar. 25, 2009

- NOTE:**
1. The calibration interval of the above test instruments is 12 months. And the calibrations are traceable to NML/ROC and NIST/USA.
 2. The horn antenna and HP preamplifier (model: 8449B) are used only for the measurement of emission frequency above 1GHz if tested.
 3. The test was performed in ADT Chamber No. 6.
 4. The Industry Canada Reference No. IC 3789-6.

4.2.3 TEST PROCEDURES

- a. The EUT was placed on the top of a rotating table 0.8 meters above the ground at a 3 meter semi-anechoic chamber. The table was rotated 360 degrees to determine the position of the highest radiation.
- b. The EUT was set 3 meters away from the interference-receiving antenna, which was mounted on the top of a variable-height antenna tower.
- c. The antenna is a broadband antenna, and its height is varied from one meter to four meters above the ground to determine the maximum value of the field strength. Both horizontal and vertical polarizations of the antenna are set to make the measurement.
- d. For each suspected emission, the EUT was arranged to its worst case and then the antenna was tuned to heights from 1 meter to 4 meters and the rotatable table was turned from 0 degrees to 360 degrees to find the maximum reading.
- e. The test-receiver system was set to Peak Detect Function and Specified Bandwidth with Maximum Hold Mode.
- f. If the emission level of the EUT in peak mode was lower than the limit specified, then testing could be stopped and the peak values of the EUT would be reported. Otherwise the emissions would be re-tested one by one using peak, quasi-peak or average method as specified and then reported in a data sheet.

NOTE:

1. The resolution bandwidth of test receiver/spectrum analyzer is 120kHz for Quasi-peak detection at frequency below 1GHz.
2. The resolution bandwidth is 1MHz and video bandwidth of test receiver/spectrum analyzer is 3MHz for Peak detection at frequency above 1GHz. The resolution bandwidth of test receiver/spectrum analyzer is 1 MHz for Average detection (AV) at frequency above 1GHz.

4.2.4 DEVIATION FROM TEST STANDARD

No deviation

4.2.5 TEST SETUP

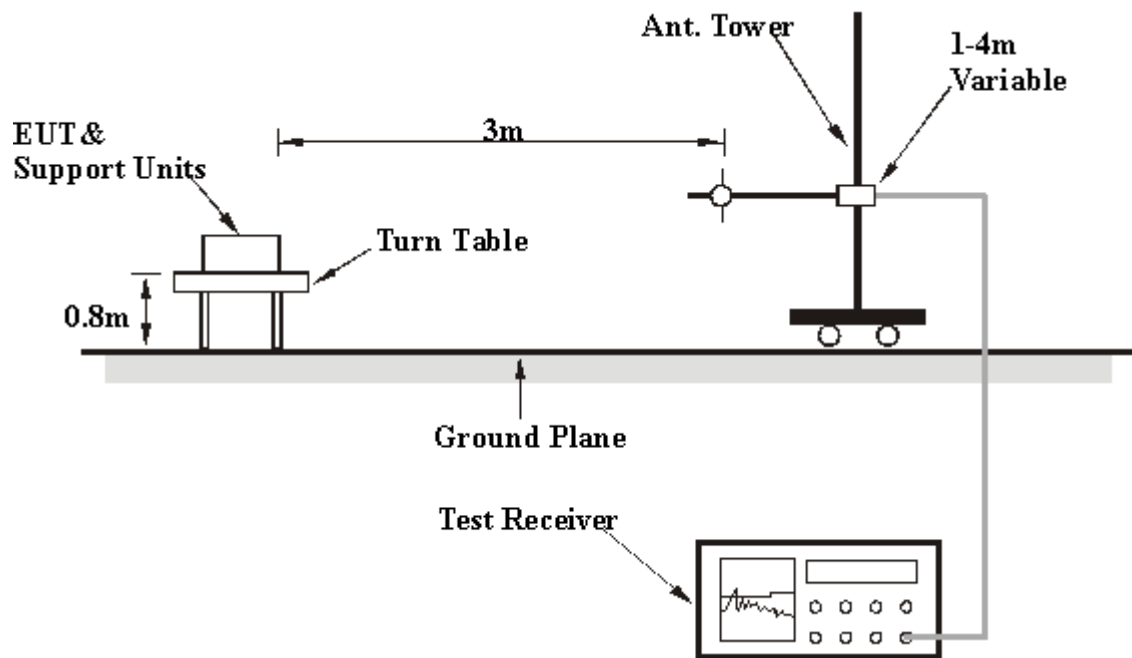

For the actual test configuration, please refer to the related item – Photographs of the Test Configuration.

4.2.6 EUT OPERATING CONDITIONS

For Mode A:

Set the EUT under transmission/receiving condition continuously at specific channel frequency.

For Mode B:

- a. Connected the EUT with an AC adapter placed on testing table.
- b. Set the EUT under charging condition.

For Mode C:

- a. Connected the EUT with car charger placed on testing table.
- b. Set the EUT under charging condition.

For Mode D:

- a. Connected the EUT to Notebook via USB cable.
- b. Turned on the power of all equipment.
- c. Notebook ran a test program to enable all functions.
- d. Notebook read and wrote messages from HDD.
- e. Notebook sent "H" messages to its screen and monitor displays "H" patterns on the screen.
- f. Notebook sent messages to printer, and then printer printed them out.
- g. Notebook sent messages to modem.
- h. Set the EUT under charging condition.
- i. Steps e-i were repeated.

4.2.7 TEST RESULTS

RADIATED WORST CASE DATA: FOR GFSK (BELOW 1GHz)

TEST MODE	Mode A		
MODULATION TYPE	GFSK	CHANNEL	78
INPUT POWER	3.7Vdc	FREQUENCY RANGE	Below 1000MHz
ENVIRONMENTAL CONDITIONS	13 deg. C, 76% RH, 1002hPa	DETECTOR FUNCTION	Quasi-Peak
TESTED BY	Jun Wu		

ANTENNA POLARITY & TEST DISTANCE: HORIZONTAL AT 3 M

No.	Freq. (MHz)	Emission Level (dBuV/m)	Limit (dBuV/m)	Margin (dB)	Antenna Height (m)	Table Angle (Degree)	Raw Value (dBuV)	Correction Factor (dB/m)
1	70.822	20.10 QP	40.00	-19.90	1.00 H	244	8.57	11.53
2	813.387	28.02 QP	46.00	-17.98	1.00 H	142	-0.36	28.38
3	821.162	26.53 QP	46.00	-19.47	1.00 H	316	-1.94	28.47
4	863.928	28.61 QP	46.00	-17.39	1.00 H	340	-0.31	28.92
5	889.198	28.54 QP	46.00	-17.46	1.00 H	256	-0.58	29.12
6	920.301	27.91 QP	46.00	-18.09	1.06 H	199	-1.45	29.36

ANTENNA POLARITY & TEST DISTANCE: VERTICAL AT 3 M

No.	Freq. (MHz)	Emission Level (dBuV/m)	Limit (dBuV/m)	Margin (dB)	Antenna Height (m)	Table Angle (Degree)	Raw Value (dBuV)	Correction Factor (dB/m)
1	63.046	22.57 QP	40.00	-17.43	1.00 V	70	10.37	12.21
2	103.868	30.65 QP	43.50	-12.85	1.33 V	199	18.66	11.99
3	846.433	28.81 QP	46.00	-17.19	1.00 V	337	0.05	28.76
4	906.693	30.05 QP	46.00	-15.95	1.00 V	121	0.80	29.26
5	935.852	32.08 QP	46.00	-13.92	1.00 V	49	2.61	29.47
6	943.627	30.51 QP	46.00	-15.49	1.00 V	22	0.99	29.52

- REMARKS:**
1. Emission level (dBuV/m) = Raw Value (dBuV) + Correction Factor (dB/m).
 2. Correction Factor (dB/m) = Antenna Factor (dB/m) + Cable Factor (dB).
 3. The other emission levels were very low against the limit.
 4. Margin value = Emission level – Limit value.

TEST MODE	Mode B		
INPUT POWER	120Vac, 60 Hz	FREQUENCY RANGE	Below 1000MHz
ENVIRONMENTAL CONDITIONS	13 deg. C, 76% RH, 1002hPa	DETECTOR FUNCTION	Quasi-Peak
TESTED BY	Jun Wu		

ANTENNA POLARITY & TEST DISTANCE: HORIZONTAL AT 3 M

No.	Freq. (MHz)	Emission Level (dBuV/m)	Limit (dBuV/m)	Margin (dB)	Antenna Height (m)	Table Angle (Degree)	Raw Value (dBuV)	Correction Factor (dB/m)
1	103.868	25.61 QP	43.50	-17.89	1.00 H	202	13.62	11.99
2	315.752	28.80 QP	46.00	-17.20	1.44 H	103	12.29	16.51
3	799.780	27.26 QP	46.00	-18.74	1.22 H	19	-0.97	28.23
4	842.545	27.91 QP	46.00	-18.09	1.30 H	79	-0.81	28.72
5	881.423	27.11 QP	46.00	-18.89	1.08 H	355	-1.95	29.06
6	930.020	27.33 QP	46.00	-18.67	1.50 H	22	-2.10	29.43

ANTENNA POLARITY & TEST DISTANCE: VERTICAL AT 3 M

No.	Freq. (MHz)	Emission Level (dBuV/m)	Limit (dBuV/m)	Margin (dB)	Antenna Height (m)	Table Angle (Degree)	Raw Value (dBuV)	Correction Factor (dB/m)
1	103.868	25.18 QP	43.50	-18.32	1.00 V	19	13.19	11.99
2	488.758	30.93 QP	46.00	-15.07	1.00 V	79	8.98	21.95
3	494.589	35.30 QP	46.00	-10.70	1.00 V	40	13.17	22.14
4	585.952	32.43 QP	46.00	-13.57	1.36 V	355	8.22	24.21
5	591.784	30.79 QP	46.00	-15.21	1.42 V	7	6.45	24.34
6	887.255	27.88 QP	46.00	-18.12	1.55 V	118	-1.23	29.11
7	916.413	27.49 QP	46.00	-18.51	1.00 V	331	-1.84	29.33

- REMARKS:**
1. Emission level (dBuV/m) = Raw Value (dBuV) + Correction Factor (dB/m).
 2. Correction Factor (dB/m) = Antenna Factor (dB/m) + Cable Factor (dB).
 3. The other emission levels were very low against the limit.
 4. Margin value = Emission level – Limit value.

TEST MODE	Mode C		
INPUT POWER	12Vdc	FREQUENCY RANGE	Below 1000MHz
ENVIRONMENTAL CONDITIONS	18 deg. C, 75% RH, 1003hPa	DETECTOR FUNCTION	Quasi-Peak
TESTED BY	Jun Wu		

ANTENNA POLARITY & TEST DISTANCE: HORIZONTAL AT 3 M

No.	Freq. (MHz)	Emission Level (dBuV/m)	Limit (dBuV/m)	Margin (dB)	Antenna Height (m)	Table Angle (Degree)	Raw Value (dBuV)	Correction Factor (dB/m)
1	39.719	19.13 QP	40.00	-20.87	1.42 H	154	4.46	14.67
2	801.723	25.64 QP	46.00	-20.36	1.24 H	97	-2.61	28.25
3	844.489	27.12 QP	46.00	-18.88	1.14 H	124	-1.62	28.74
4	879.479	26.96 QP	46.00	-19.04	1.10 H	148	-2.08	29.04
5	918.357	27.03 QP	46.00	-18.97	1.07 H	292	-2.31	29.34
6	957.234	27.63 QP	46.00	-18.37	1.02 H	223	-2.08	29.71

ANTENNA POLARITY & TEST DISTANCE: VERTICAL AT 3 M

No.	Freq. (MHz)	Emission Level (dBuV/m)	Limit (dBuV/m)	Margin (dB)	Antenna Height (m)	Table Angle (Degree)	Raw Value (dBuV)	Correction Factor (dB/m)
1	31.944	24.94 QP	40.00	-15.06	1.00 V	139	11.86	13.09
2	117.475	26.78 QP	43.50	-16.72	1.00 V	43	13.66	13.12
3	861.984	26.89 QP	46.00	-19.11	1.12 V	193	-2.01	28.90
4	893.086	26.23 QP	46.00	-19.77	1.27 V	271	-2.92	29.15
5	922.244	27.62 QP	46.00	-18.38	1.15 V	151	-1.75	29.37
6	947.515	28.60 QP	46.00	-17.40	1.23 V	253	-0.95	29.55

- REMARKS:**
1. Emission level (dBuV/m) = Raw Value (dBuV) + Correction Factor (dB/m).
 2. Correction Factor (dB/m) = Antenna Factor (dB/m) + Cable Factor (dB).
 3. The other emission levels were very low against the limit.
 4. Margin value = Emission level – Limit value.

TEST MODE	Mode D		
INPUT POWER (SYSTEM)	120Vac, 60 Hz	FREQUENCY RANGE	Below 1000MHz
ENVIRONMENTAL CONDITIONS	13 deg. C, 76% RH, 1002hPa	DETECTOR FUNCTION	Quasi-Peak
TESTED BY	Jun Wu		

ANTENNA POLARITY & TEST DISTANCE: HORIZONTAL AT 3 M

No.	Freq. (MHz)	Emission Level (dBuV/m)	Limit (dBuV/m)	Margin (dB)	Antenna Height (m)	Table Angle (Degree)	Raw Value (dBuV)	Correction Factor (dB/m)
1	168.016	30.52 QP	43.50	-12.98	1.07 H	106	17.30	13.22
2	399.339	31.40 QP	46.00	-14.60	1.00 H	10	12.35	19.05
3	521.804	33.12 QP	46.00	-12.88	1.66 H	208	10.31	22.81
4	667.595	33.13 QP	46.00	-12.87	1.28 H	10	7.70	25.43
5	733.687	31.12 QP	46.00	-14.88	1.00 H	160	4.34	26.78
6	900.862	31.45 QP	46.00	-14.55	1.00 H	316	2.23	29.22
7	933.908	31.33 QP	46.00	-14.67	1.00 H	352	1.87	29.45

ANTENNA POLARITY & TEST DISTANCE: VERTICAL AT 3 M

No.	Freq. (MHz)	Emission Level (dBuV/m)	Limit (dBuV/m)	Margin (dB)	Antenna Height (m)	Table Angle (Degree)	Raw Value (dBuV)	Correction Factor (dB/m)
1	127.194	30.71 QP	43.50	-12.79	1.00 V	193	17.48	13.23
2	249.659	32.54 QP	46.00	-13.46	1.00 V	172	17.74	14.80
3	399.339	38.70 QP	46.00	-7.30	1.62 V	193	19.65	19.05
4	533.467	33.75 QP	46.00	-12.25	1.33 V	91	10.68	23.07
5	673.427	32.10 QP	46.00	-13.90	1.00 V	112	6.58	25.52
6	757.014	32.25 QP	46.00	-13.75	1.42 V	19	4.92	27.33
7	900.862	33.29 QP	46.00	-12.71	1.00 V	262	4.07	29.22

- REMARKS:**
1. Emission level (dBuV/m) = Raw Value (dBuV) + Correction Factor (dB/m).
 2. Correction Factor (dB/m) = Antenna Factor (dB/m) + Cable Factor (dB).
 3. The other emission levels were very low against the limit.
 4. Margin value = Emission level – Limit value.

RADIATED WORST CASE DATA: FOR GFSK (ABOVE 1GHz)

TEST MODE	Mode A		
MODULATION TYPE	GFSK	CHANNEL	0
INPUT POWER	3.7Vdc	FREQUENCY RANGE	1 ~ 25GHz
ENVIRONMENTAL CONDITIONS	13 deg. C, 76% RH, 1007hPa	DETECTOR FUNCTION	Peak (PK) Average (AV)
TESTED BY	Jun Wu		

ANTENNA POLARITY & TEST DISTANCE: HORIZONTAL AT 3 M

No.	Freq. (MHz)	Emission Level (dBuV/m)	Limit (dBuV/m)	Margin (dB)	Antenna Height (m)	Table Angle (Degree)	Raw Value (dBuV)	Correction Factor (dB/m)
1	1602.000	47.46 PK	74.00	-26.54	1.00 H	264	15.16	32.30
2	1602.000	40.27 AV	54.00	-13.73	1.00 H	264	7.97	32.30
3	2390.000	59.74 PK	74.00	-14.26	1.00 H	266	25.08	34.66
4	2390.000	29.64 AV	54.00	-24.36	1.00 H	266	-5.02	34.66
5	*2402.000	104.79 PK			1.00 H	266	70.10	34.69
6	*2402.000	74.69 AV			1.00 H	266	40.00	34.69
7	4804.000	58.94 PK	74.00	-15.06	1.00 H	140	17.09	41.85
8	4804.000	28.84 AV	54.00	-25.16	1.00 H	140	-13.01	41.85

ANTENNA POLARITY & TEST DISTANCE: VERTICAL AT 3 M

No.	Freq. (MHz)	Emission Level (dBuV/m)	Limit (dBuV/m)	Margin (dB)	Antenna Height (m)	Table Angle (Degree)	Raw Value (dBuV)	Correction Factor (dB/m)
1	1602.000	45.29 PK	74.00	-28.71	1.00 V	189	12.99	32.30
2	1602.000	35.30 AV	54.00	-18.70	1.00 V	189	3.00	32.30
3	2390.000	60.47 PK	74.00	-13.53	1.00 V	203	25.81	34.66
4	2390.000	30.37 AV	54.00	-23.63	1.00 V	203	-4.29	34.66
5	*2402.000	103.17 PK			1.00 V	203	68.48	34.69
6	*2402.000	73.07 AV			1.00 V	203	38.38	34.69
7	4804.000	63.24 PK	74.00	-10.76	1.00 V	168	21.39	41.85
8	4804.000	33.14 AV	54.00	-20.86	1.00 V	168	-8.71	41.85

- REMARKS:**
1. Emission level (dBuV/m) = Raw Value (dBuV) + Correction Factor (dB/m).
 2. Correction Factor (dB/m) = Antenna Factor (dB/m) + Cable Factor (dB).
 3. The other emission levels were very low against the limit.
 4. Margin value = Emission level – Limit value.
 5. The DH5 packet was the worse case duty cycle for a transmit dwell time on a channel, based upon bluetooth theory the transmitter is on $0.625 * 5$ per 296.25 ms per channel. Therefore, the duty cycle be equal to: $20\log(3.125/100) = -30.1$ dB.
 6. Average value = peak reading + $20\log(\text{duty cycle})$.

TEST MODE	Mode A		
MODULATION TYPE	GFSK	CHANNEL	39
INPUT POWER	3.7Vdc	FREQUENCY RANGE	1 ~ 25GHz
ENVIRONMENTAL CONDITIONS	13 deg. C, 76% RH, 1007hPa	DETECTOR FUNCTION	Peak (PK) Average (AV)
TESTED BY	Jun Wu		

ANTENNA POLARITY & TEST DISTANCE: HORIZONTAL AT 3 M

No.	Freq. (MHz)	Emission Level (dBuV/m)	Limit (dBuV/m)	Margin (dB)	Antenna Height (m)	Table Angle (Degree)	Raw Value (dBuV)	Correction Factor (dB/m)
1	1626.000	47.05 PK	74.00	-26.95	1.00 H	262	14.66	32.39
2	1626.000	39.88 AV	54.00	-14.12	1.00 H	262	7.49	32.39
3	*2441.000	107.25 PK			1.03 H	273	72.48	34.77
4	*2441.000	77.15 AV			1.03 H	273	42.38	34.77
5	4882.000	57.45 PK	74.00	-16.55	1.00 H	139	15.40	42.05
6	4882.000	27.35 AV	54.00	-26.65	1.00 H	139	-14.70	42.05

ANTENNA POLARITY & TEST DISTANCE: VERTICAL AT 3 M

No.	Freq. (MHz)	Emission Level (dBuV/m)	Limit (dBuV/m)	Margin (dB)	Antenna Height (m)	Table Angle (Degree)	Raw Value (dBuV)	Correction Factor (dB/m)
1	1626.000	44.48 PK	74.00	-29.52	1.01 V	155	12.09	32.39
2	1626.000	33.02 AV	54.00	-20.98	1.01 V	155	0.63	32.39
3	*2441.000	102.13 PK			1.00 V	283	67.36	34.77
4	*2441.000	72.03 AV			1.00 V	283	37.26	34.77
5	4882.000	61.39 PK	74.00	-12.61	1.00 V	141	19.34	42.05
6	4882.000	31.29 AV	54.00	-22.71	1.00 V	141	-10.76	42.05

- REMARKS:**
1. Emission level (dBuV/m) = Raw Value (dBuV) + Correction Factor (dB/m).
 2. Correction Factor (dB/m) = Antenna Factor (dB/m) + Cable Factor (dB).
 3. The other emission levels were very low against the limit.
 4. Margin value = Emission level – Limit value.
 5. The DH5 packet was the worse case duty cycle for a transmit dwell time on a channel, based upon bluetooth theory the transmitter is on 0.625 * 5 per 296.25 ms per channel. Therefore, the duty cycle be equal to: $20\log(3.125/100) = -30.1$ dB.
 6. Average value = peak reading + $20\log(\text{duty cycle})$.

TEST MODE	Mode A		
MODULATION TYPE	GFSK	CHANNEL	78
INPUT POWER	3.7Vdc	FREQUENCY RANGE	1 ~ 25GHz
ENVIRONMENTAL CONDITIONS	13 deg. C, 76% RH, 1007hPa	DETECTOR FUNCTION	Peak (PK) Average (AV)
TESTED BY	Jun Wu		

ANTENNA POLARITY & TEST DISTANCE: HORIZONTAL AT 3 M

No.	Freq. (MHz)	Emission Level (dBuV/m)	Limit (dBuV/m)	Margin (dB)	Antenna Height (m)	Table Angle (Degree)	Raw Value (dBuV)	Correction Factor (dB/m)
1	1652.000	45.38 PK	74.00	-28.62	1.00 H	288	12.88	32.50
2	1652.000	37.24 AV	54.00	-16.76	1.00 H	288	4.74	32.50
3	*2480.000	107.21 PK			1.06 H	273	72.36	34.85
4	*2480.000	77.11 AV			1.06 H	273	42.26	34.85
5	2483.500	70.54 PK	74.00	-3.46	1.06 H	273	35.68	34.86
6	2483.500	40.44 AV	54.00	-13.56	1.06 H	273	5.58	34.86
7	4960.000	55.33 PK	74.00	-18.67	1.00 H	137	13.08	42.26
8	4960.000	25.23 AV	54.00	-28.77	1.00 H	137	-17.02	42.26

ANTENNA POLARITY & TEST DISTANCE: VERTICAL AT 3 M

No.	Freq. (MHz)	Emission Level (dBuV/m)	Limit (dBuV/m)	Margin (dB)	Antenna Height (m)	Table Angle (Degree)	Raw Value (dBuV)	Correction Factor (dB/m)
1	1652.000	43.95 PK	74.00	-30.05	1.00 V	158	11.45	32.50
2	1652.000	31.97 AV	54.00	-22.03	1.00 V	158	-0.53	32.50
3	*2480.000	101.20 PK			1.00 V	238	66.35	34.85
4	*2480.000	71.10 AV			1.00 V	238	36.25	34.85
5	2483.500	65.62 PK	74.00	-8.38	1.00 V	238	30.76	34.86
6	2483.500	35.52 AV	54.00	-18.48	1.00 V	238	0.66	34.86
7	4960.000	58.63 PK	74.00	-15.37	1.00 V	156	16.38	42.26
8	4960.000	28.53 AV	54.00	-25.47	1.00 V	156	-13.72	42.26

- REMARKS:**
1. Emission level (dBuV/m) = Raw Value (dBuV) + Correction Factor (dB/m).
 2. Correction Factor (dB/m) = Antenna Factor (dB/m) + Cable Factor (dB).
 3. The other emission levels were very low against the limit.
 4. Margin value = Emission level – Limit value.
 5. The DH5 packet was the worse case duty cycle for a transmit dwell time on a channel, based upon bluetooth theory the transmitter is on $0.625 * 5$ per 296.25 ms per channel. Therefore, the duty cycle be equal to: $20\log(3.125/100) = -30.1$ dB.
 6. Average value = peak reading + $20\log(\text{duty cycle})$.

RADIATED WORST CASE DATA: MODE A FOR 8DPSK (ABOVE 1GHz)

TEST MODE	Mode A		
MODULATION TYPE	8DPSK	CHANNEL	0
INPUT POWER	3.7Vdc	FREQUENCY RANGE	1 ~ 25GHz
ENVIRONMENTAL CONDITIONS	13 deg. C, 76% RH, 1008hPa	DETECTOR FUNCTION	Peak (PK) Average (AV)
TESTED BY	Jun Wu		

ANTENNA POLARITY & TEST DISTANCE: HORIZONTAL AT 3 M

No.	Freq. (MHz)	Emission Level (dBuV/m)	Limit (dBuV/m)	Margin (dB)	Antenna Height (m)	Table Angle (Degree)	Raw Value (dBuV)	Correction Factor (dB/m)
1	1602.000	45.98 PK	74.00	-28.02	1.00 H	84	13.68	32.30
2	1602.000	37.76 AV	54.00	-16.24	1.00 H	84	5.46	32.30
3	2390.000	59.72 PK	74.00	-14.28	1.00 H	290	25.06	34.66
4	2390.000	29.62 AV	54.00	-24.38	1.00 H	290	-5.04	34.66
5	*2402.000	106.21 PK			1.00 H	290	71.52	34.69
6	*2402.000	76.11 AV			1.00 H	290	41.42	34.69
7	4804.000	51.77 PK	74.00	-22.23	1.00 H	38	9.92	41.85
8	4804.000	21.67 AV	54.00	-32.33	1.00 H	38	-20.18	41.85

ANTENNA POLARITY & TEST DISTANCE: VERTICAL AT 3 M

No.	Freq. (MHz)	Emission Level (dBuV/m)	Limit (dBuV/m)	Margin (dB)	Antenna Height (m)	Table Angle (Degree)	Raw Value (dBuV)	Correction Factor (dB/m)
1	1602.000	43.78 PK	74.00	-30.22	1.00 V	328	11.48	32.30
2	1602.000	32.81 AV	54.00	-21.19	1.00 V	328	0.51	32.30
3	2390.000	59.83 PK	74.00	-14.17	1.00 V	147	25.17	34.66
4	2390.000	29.73 AV	54.00	-24.27	1.00 V	147	-4.93	34.66
5	*2402.000	104.07 PK			1.00 V	147	69.38	34.69
6	*2402.000	73.97 AV			1.00 V	147	39.28	34.69
7	4804.000	57.92 PK	74.00	-16.08	1.00 V	0	16.07	41.85
8	4804.000	27.82 AV	54.00	-26.18	1.00 V	0	-14.03	41.85

- REMARKS:**
1. Emission level (dBuV/m) = Raw Value (dBuV) + Correction Factor (dB/m).
 2. Correction Factor (dB/m) = Antenna Factor (dB/m) + Cable Factor (dB).
 3. The other emission levels were very low against the limit.
 4. Margin value = Emission level – Limit value.
 5. The DH5 packet was the worse case duty cycle for a transmit dwell time on a channel, based upon bluetooth theory the transmitter is on 0.625 * 5 per 296.25 ms per channel. Therefore, the duty cycle be equal to: $20\log(3.125/100) = -30.1$ dB.
 6. Average value = peak reading + $20\log(\text{duty cycle})$.

TEST MODE	Mode A		
MODULATION TYPE	8DPSK	CHANNEL	39
INPUT POWER	3.7Vdc	FREQUENCY RANGE	1 ~ 25GHz
ENVIRONMENTAL CONDITIONS	13 deg. C, 76% RH, 1008hPa	DETECTOR FUNCTION	Peak (PK) Average (AV)
TESTED BY	Jun Wu		

ANTENNA POLARITY & TEST DISTANCE: HORIZONTAL AT 3 M

No.	Freq. (MHz)	Emission Level (dBuV/m)	Limit (dBuV/m)	Margin (dB)	Antenna Height (m)	Table Angle (Degree)	Raw Value (dBuV)	Correction Factor (dB/m)
1	1626.000	45.28 PK	74.00	-28.72	1.00 H	130	12.89	32.39
2	1626.000	35.96 AV	54.00	-18.04	1.00 H	130	3.57	32.39
3	*2441.000	106.62 PK			1.03 H	286	71.85	34.77
4	*2441.000	76.52 AV			1.03 H	286	41.75	34.77
5	4882.000	52.86 PK	74.00	-21.14	1.04 H	332	10.81	42.05
6	4882.000	22.76 AV	54.00	-31.24	1.04 H	332	-19.29	42.05

ANTENNA POLARITY & TEST DISTANCE: VERTICAL AT 3 M

No.	Freq. (MHz)	Emission Level (dBuV/m)	Limit (dBuV/m)	Margin (dB)	Antenna Height (m)	Table Angle (Degree)	Raw Value (dBuV)	Correction Factor (dB/m)
1	1626.000	44.82 PK	74.00	-29.18	1.05 V	123	12.43	32.39
2	1626.000	33.52 AV	54.00	-20.48	1.05 V	123	1.13	32.39
3	*2441.000	100.28 PK			1.09 V	172	65.51	34.77
4	*2441.000	70.18 AV			1.09 V	172	35.41	34.77
5	4882.000	54.96 PK	74.00	-19.04	1.13 V	230	12.91	42.05
6	4882.000	24.86 AV	54.00	-29.14	1.13 V	230	-17.19	42.05

- REMARKS:**
1. Emission level (dBuV/m) = Raw Value (dBuV) + Correction Factor (dB/m).
 2. Correction Factor (dB/m) = Antenna Factor (dB/m) + Cable Factor (dB).
 3. The other emission levels were very low against the limit.
 4. Margin value = Emission level – Limit value.
 5. The DH5 packet was the worse case duty cycle for a transmit dwell time on a channel, based upon bluetooth theory the transmitter is on $0.625 * 5$ per 296.25 ms per channel. Therefore, the duty cycle be equal to: $20\log(3.125/100) = -30.1$ dB.
 6. Average value = peak reading + $20\log(\text{duty cycle})$.

TEST MODE	Mode A		
MODULATION TYPE	8DPSK	CHANNEL	78
INPUT POWER	3.7Vdc	FREQUENCY RANGE	1 ~ 25GHz
ENVIRONMENTAL CONDITIONS	13 deg. C, 76% RH, 1008hPa	DETECTOR FUNCTION	Peak (PK) Average (AV)
TESTED BY	Jun Wu		

ANTENNA POLARITY & TEST DISTANCE: HORIZONTAL AT 3 M

No.	Freq. (MHz)	Emission Level (dBuV/m)	Limit (dBuV/m)	Margin (dB)	Antenna Height (m)	Table Angle (Degree)	Raw Value (dBuV)	Correction Factor (dB/m)
1	1652.000	45.49 PK	74.00	-28.51	1.09 H	84	12.99	32.50
2	1652.000	36.26 AV	54.00	-17.74	1.09 H	84	3.76	32.50
3	*2480.000	104.12 PK			1.12 H	78	69.27	34.85
4	*2480.000	74.02 AV			1.12 H	78	39.17	34.85
5	2483.500	68.00 PK	74.00	-6.00	1.12 H	78	33.14	34.86
6	2483.500	37.90 AV	54.00	-16.10	1.12 H	78	3.04	34.86
7	4960.000	53.36 PK	74.00	-20.64	1.00 H	303	11.11	42.26
8	4960.000	23.26 AV	54.00	-30.74	1.00 H	303	-18.99	42.26

ANTENNA POLARITY & TEST DISTANCE: VERTICAL AT 3 M

No.	Freq. (MHz)	Emission Level (dBuV/m)	Limit (dBuV/m)	Margin (dB)	Antenna Height (m)	Table Angle (Degree)	Raw Value (dBuV)	Correction Factor (dB/m)
1	1652.000	44.94 PK	74.00	-29.06	1.00 V	124	12.44	32.50
2	1652.000	32.67 AV	54.00	-21.33	1.00 V	124	0.17	32.50
3	*2480.000	100.73 PK			1.13 V	171	65.88	34.85
4	*2480.000	70.63 AV			1.13 V	171	35.78	34.85
5	2483.500	65.77 PK	74.00	-8.23	1.13 V	171	30.91	34.86
6	2483.500	35.67 AV	54.00	-18.33	1.13 V	171	0.81	34.86
7	4960.000	55.64 PK	74.00	-18.36	1.00 V	277	13.39	42.26
8	4960.000	25.54 AV	54.00	-28.46	1.00 V	277	-16.71	42.26

- REMARKS:**
1. Emission level (dBuV/m) = Raw Value (dBuV) + Correction Factor (dB/m).
 2. Correction Factor (dB/m) = Antenna Factor (dB/m) + Cable Factor (dB).
 3. The other emission levels were very low against the limit.
 4. Margin value = Emission level – Limit value.
 5. The DH5 packet was the worse case duty cycle for a transmit dwell time on a channel, based upon bluetooth theory the transmitter is on 0.625 * 5 per 296.25 ms per channel. Therefore, the duty cycle be equal to: $20\log(3.125/100) = -30.1$ dB.
 6. Average value = peak reading + $20\log(\text{duty cycle})$.



4.3 NUMBER OF HOPPING FREQUENCY USED

4.3.1 LIMIT OF HOPPING FREQUENCY USED

At least 15 channels frequencies, and should be equally spaced.

4.3.2 TEST INSTRUMENTS

DESCRIPTION & MANUFACTURER	MODEL NO.	SERIAL NO.	CALIBRATED UNTIL
SPECTRUM ANALYZER	FSP 40	100036	Mar. 12, 2009

NOTE: The calibration interval of the above test instruments is 12 months. And the calibrations are traceable to NML/ROC and NIST/USA.

4.3.3 TEST PROCEDURES

- a. Check the calibration of the measuring instrument (SA) using either an internal calibrator or a known signal from an external generator.
- b. Turn on the EUT and connect its antenna terminal to measurement via a low loss cable. Then set it to any one measured frequency within its operating range and make sure the instrument is operated in its linear range.
- c. Set the SA on MaxHold Mode, and then keep the EUT in hopping mode. Record all the signals from each channel until each one has been recorded.
- d. Set the SA on View mode and then plot the result on SA screen.
- e. Repeat above procedures until all frequencies measured were complete.

4.3.4 DEVIATION FROM TEST STANDARD

No deviation.

4.3.5 TEST SETUP

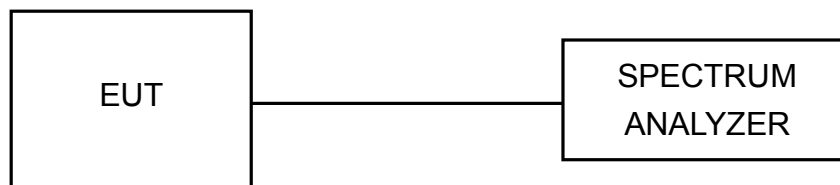

4.3.6 TEST RESULTS

There are 79 hopping frequencies in the hopping mode. Please refer to next two pages for the test result. On the plots, it shows that the hopping frequencies are equally spaced.

Mode A: FOR 8DPSK

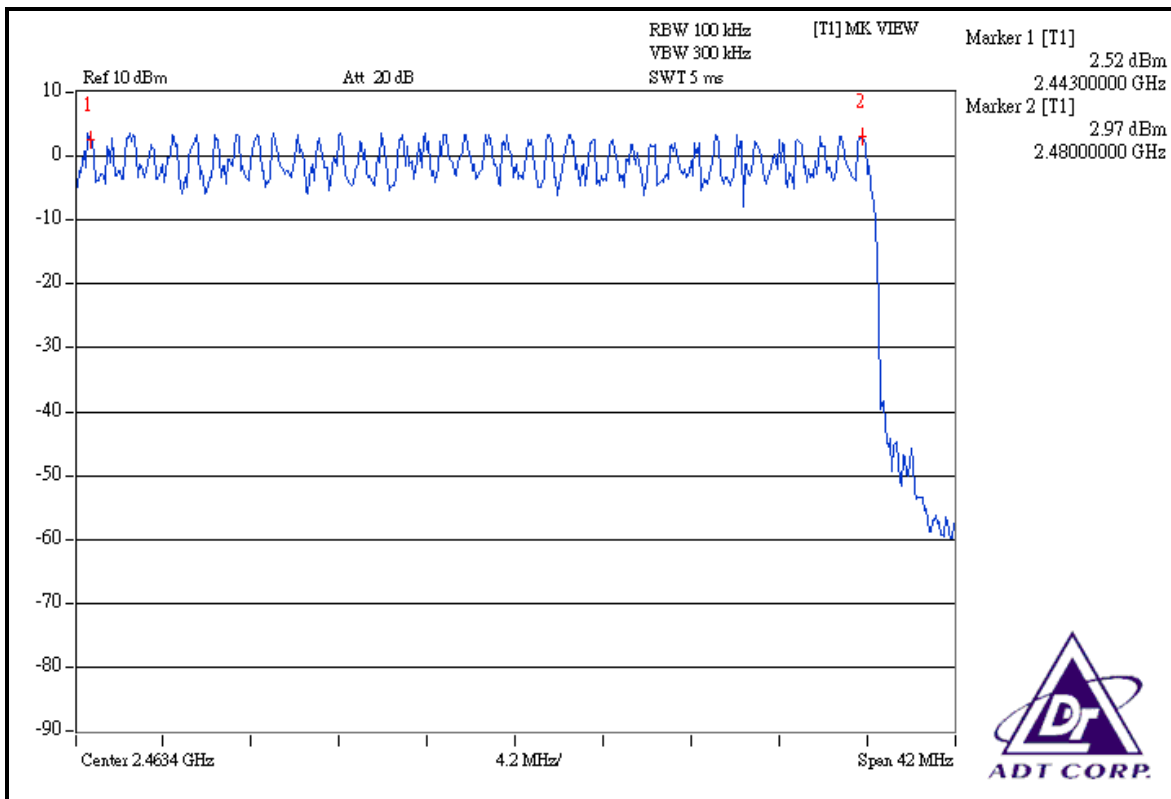
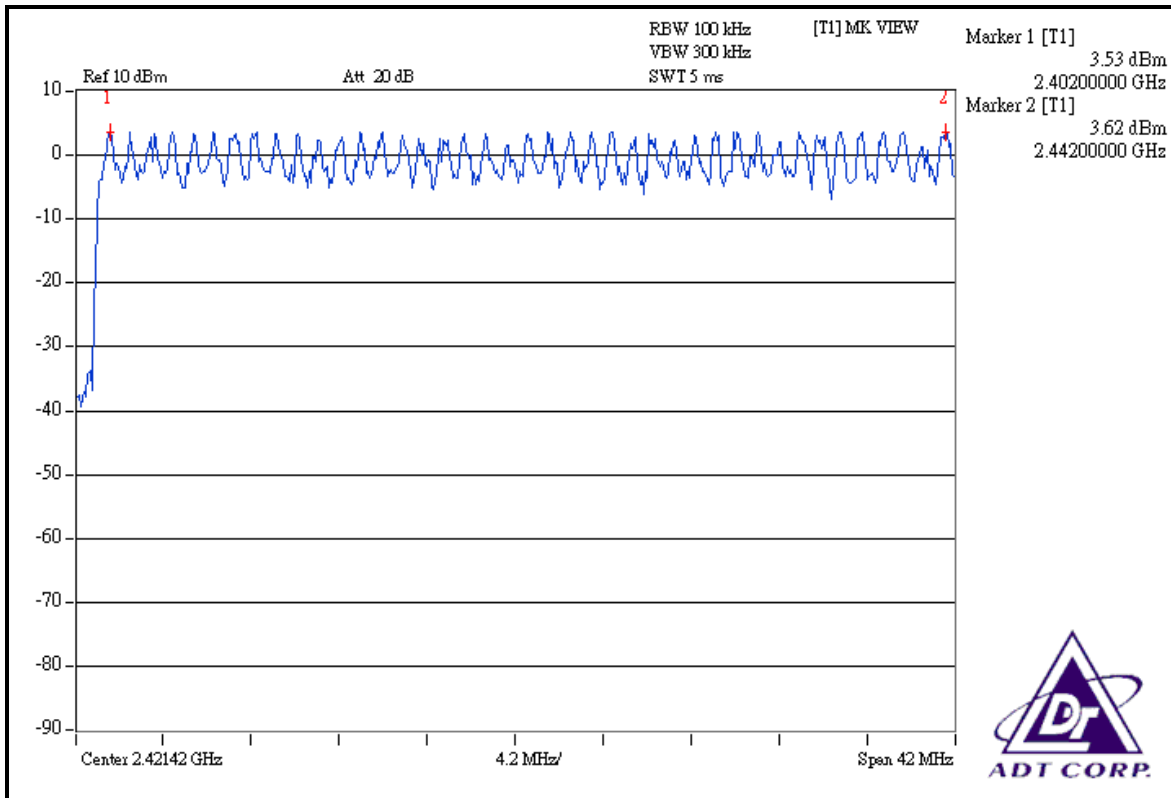



4.4 DWELL TIME ON EACH CHANNEL

4.4.1 LIMIT OF DWELL TIME USED

The average time of occupancy on any channel shall not be greater than 0.4 seconds within a period of 0.4 seconds multiplied by the number of hopping channels employed.

4.4.2 TEST INSTRUMENTS

DESCRIPTION & MANUFACTURER	MODEL NO.	SERIAL NO.	CALIBRATED UNTIL
SPECTRUM ANALYZER	FSP 40	100036	Mar. 12, 2009

NOTES: The calibration interval of the above test instruments is 12 months. And the calibrations are traceable to NML/ROC and NIST/USA.

4.4.3 TEST PROCEDURES

- a. Check the calibration of the measuring instrument (SA) using either an internal calibrator or a known signal from an external generator.
- b. Turn on the EUT and connect its antenna terminal to measurement via a low loss cable. Then set it to any one measured frequency within its operating range and make sure the instrument is operated in its linear range.
- c. Adjust the center frequency of SA on any frequency to be measured and set SA to zero span mode. And then, set RBW and VBW of spectrum analyzer to proper value.
- d. Measure the time duration of one transmission on the measured frequency. And then plot the result with time difference of this time duration.
- e. Repeat above procedures until all different time-slot modes have been completed.

4.4.4 DEVIATION FROM TEST STANDARD

No deviation.

4.4.5 TEST SETUP

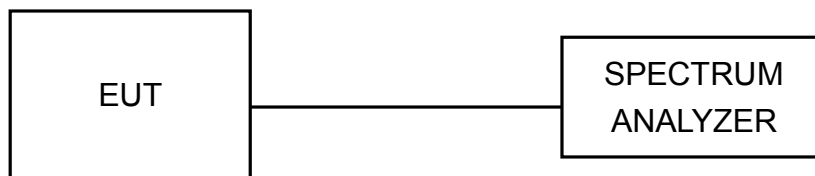

4.4.6 TEST RESULTS

Mode A: FOR GFSK

Mode	Number of transmission in a 31.6 (79Hopping*0.4)	Length of transmission time (msec)	Result (msec)	Limit (msec)
DH1	50 (times / 5 sec) *6.32=316.00 times	0.468	147.888	400
DH3	26 (times / 5 sec) *6.32=164.32 times	1.704	280.001	400
DH5	17 (times / 5 sec) *6.32=107.44 times	2.970	319.097	400

NOTE: Test plots of the transmitting time slot are shown on next 3 pages.

DH1

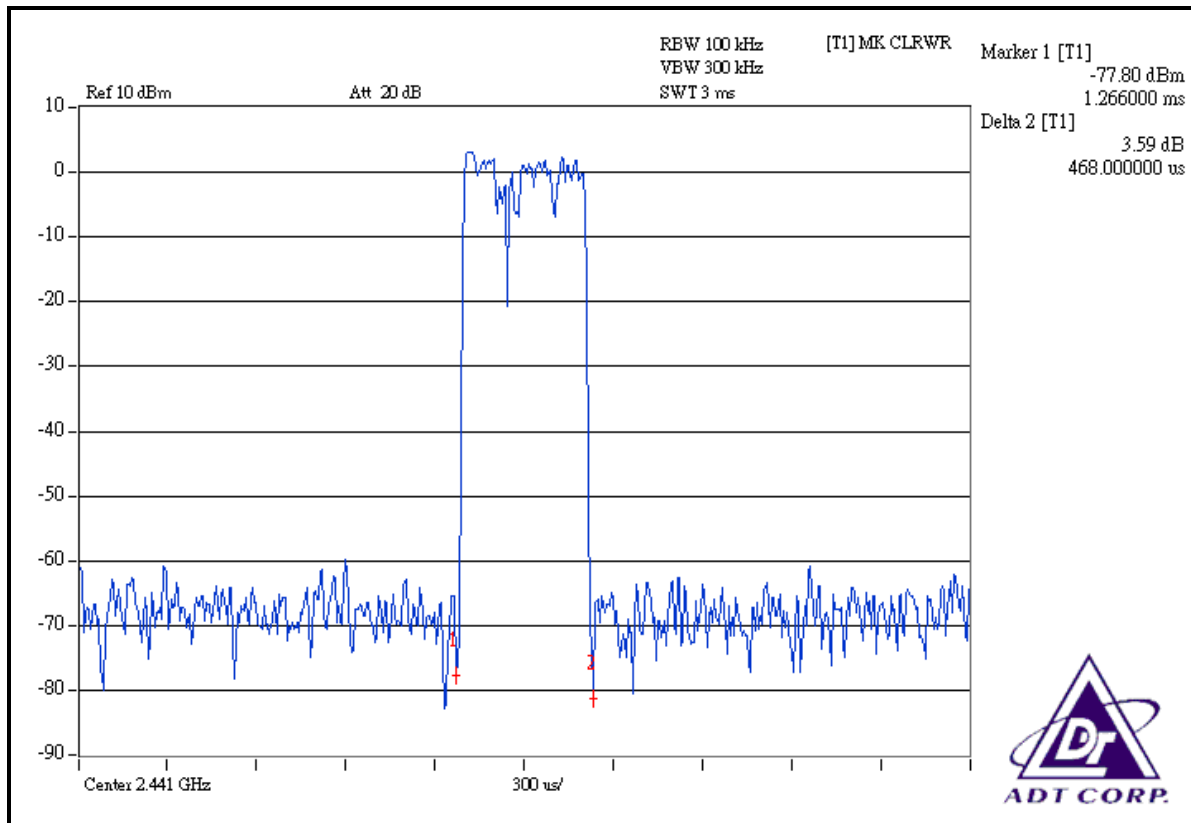
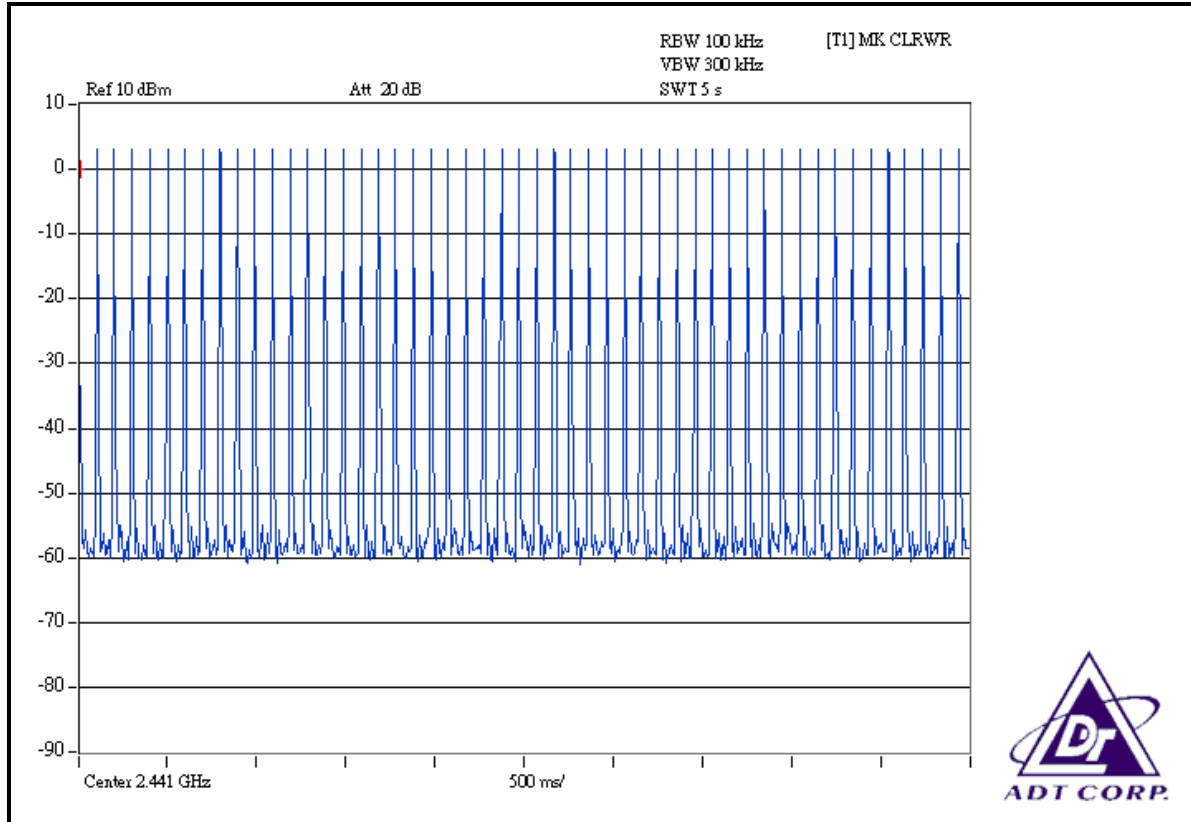

DH3

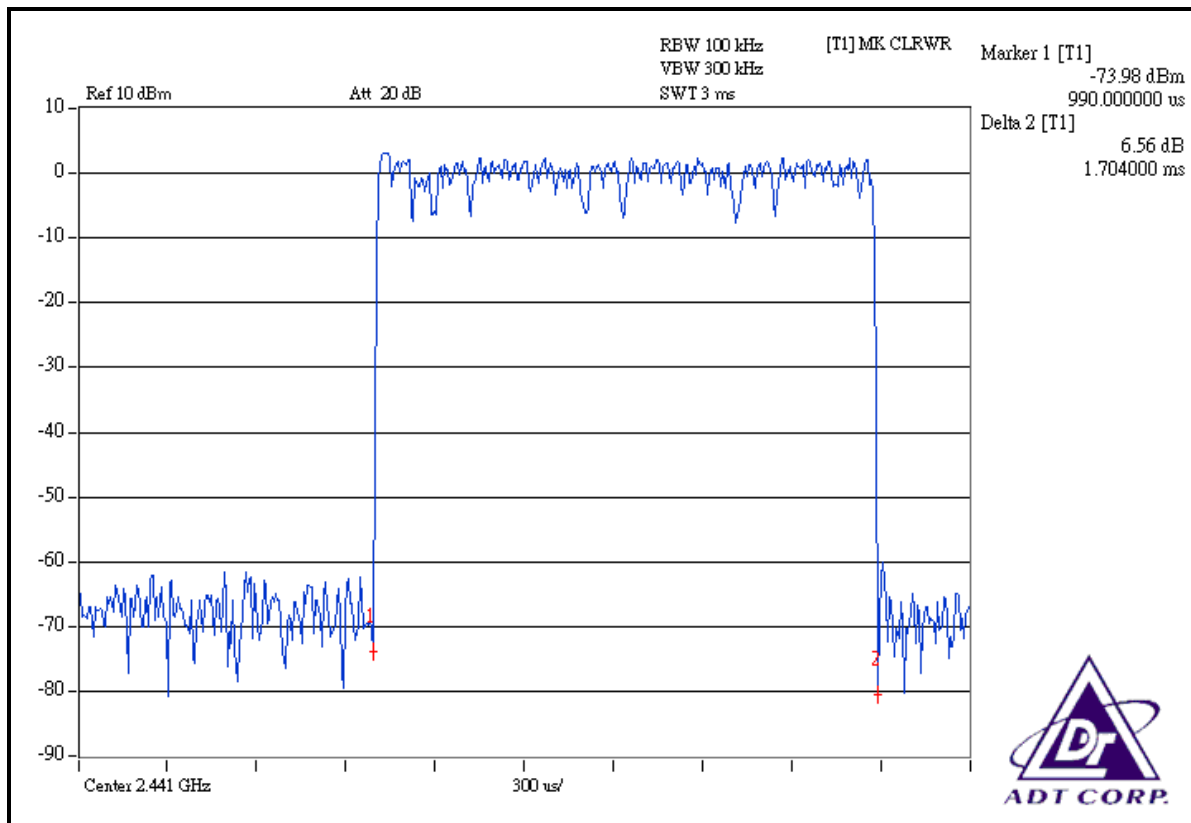
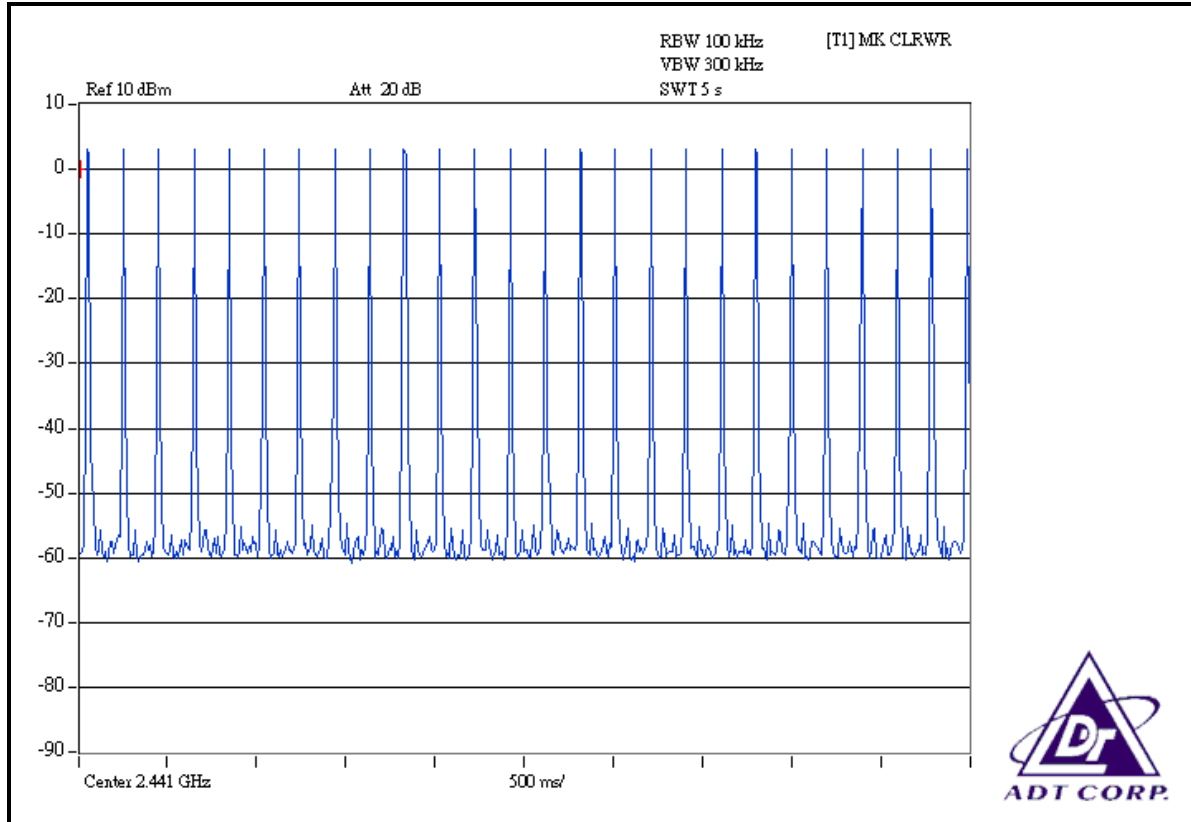

DH5

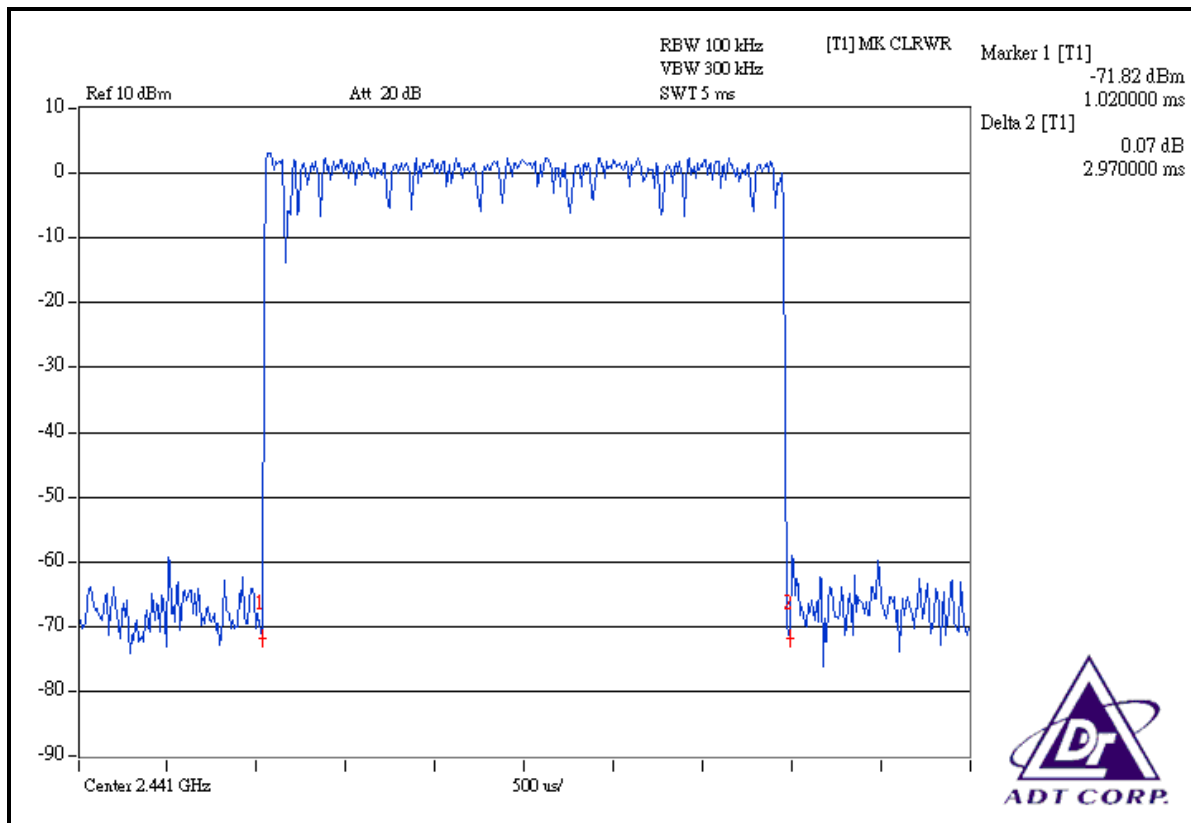
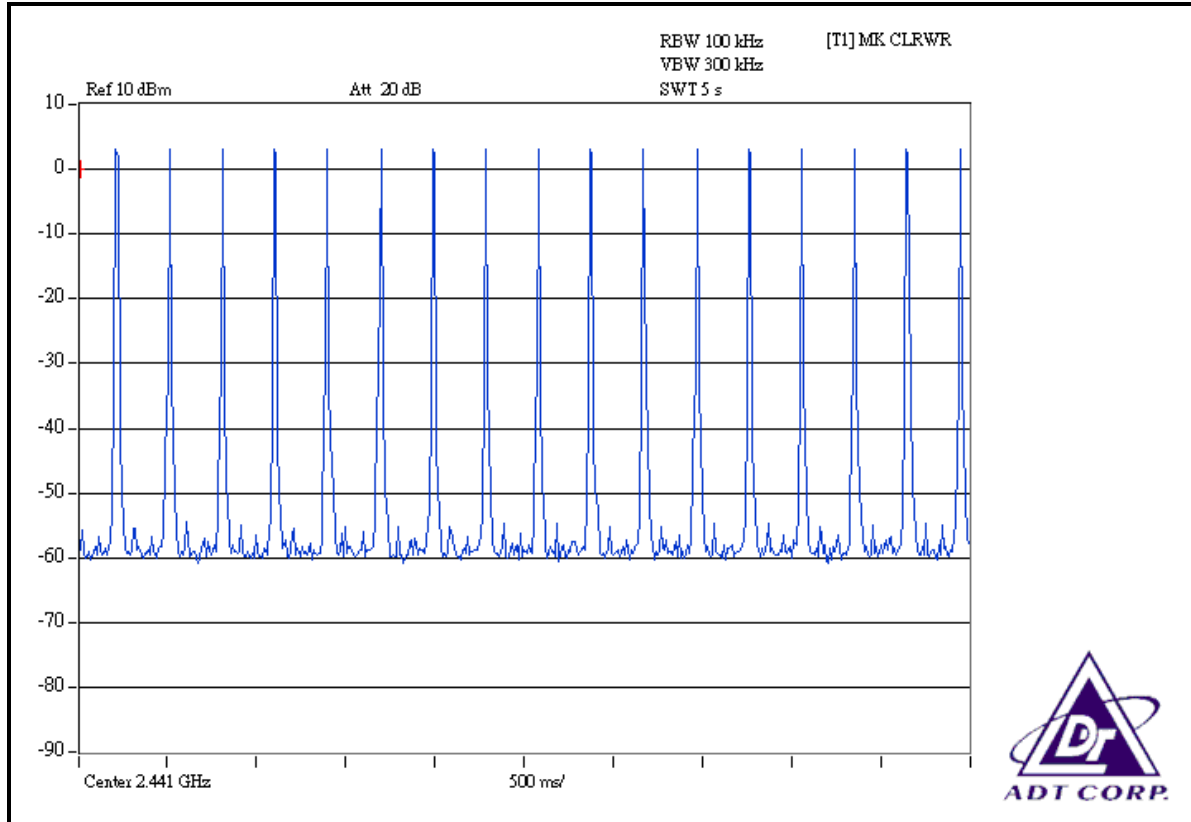

Mode A: FOR 8DPSK

Mode	Number of transmission in a 31.6 (79Hopping*0.4)	Length of transmission time (msec)	Result (msec)	Limit (msec)
DH1	50 (times / 5 sec) *6.32=316.00 times	0.462	145.992	400
DH3	25 (times / 5 sec) *6.32=158.00 times	1.716	271.128	400
DH5	16 (times / 5 sec) *6.32=101.12 times	3.010	304.371	400

NOTE: Test plots of the transmitting time slot are shown on next 3 pages.

DH1

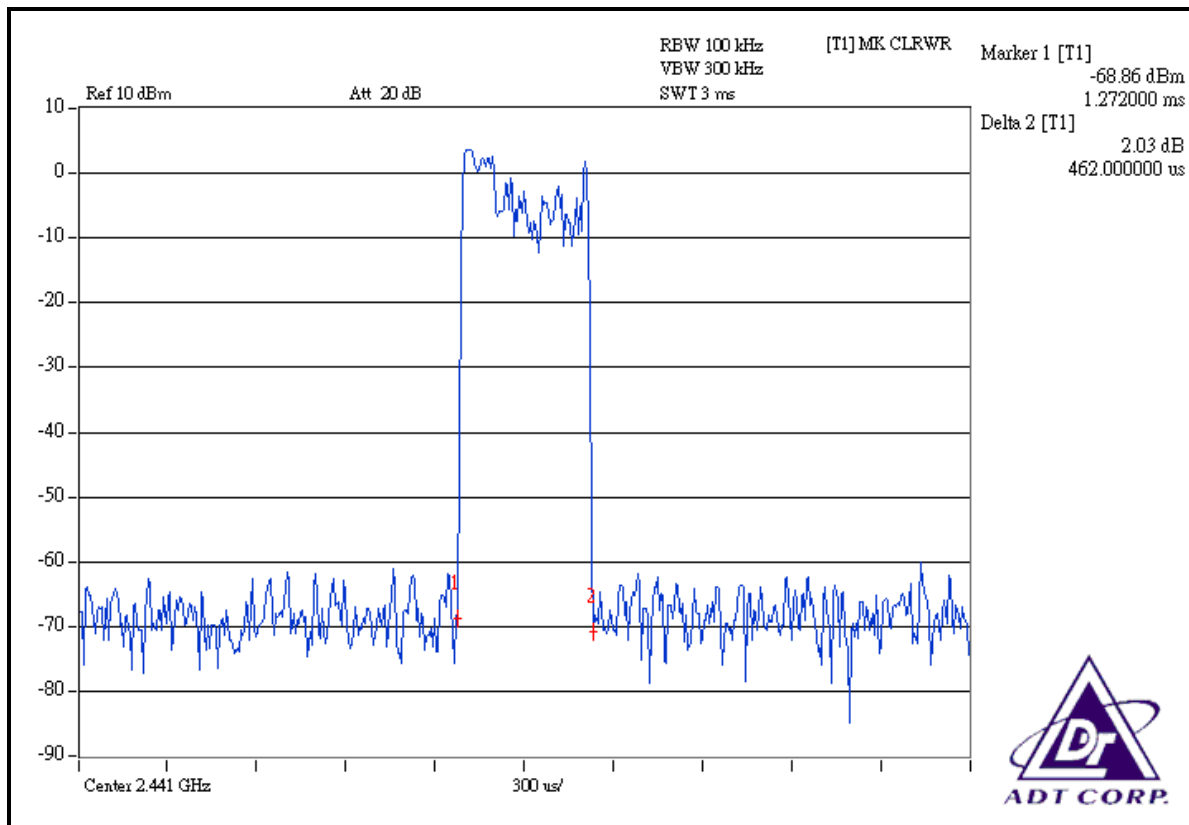
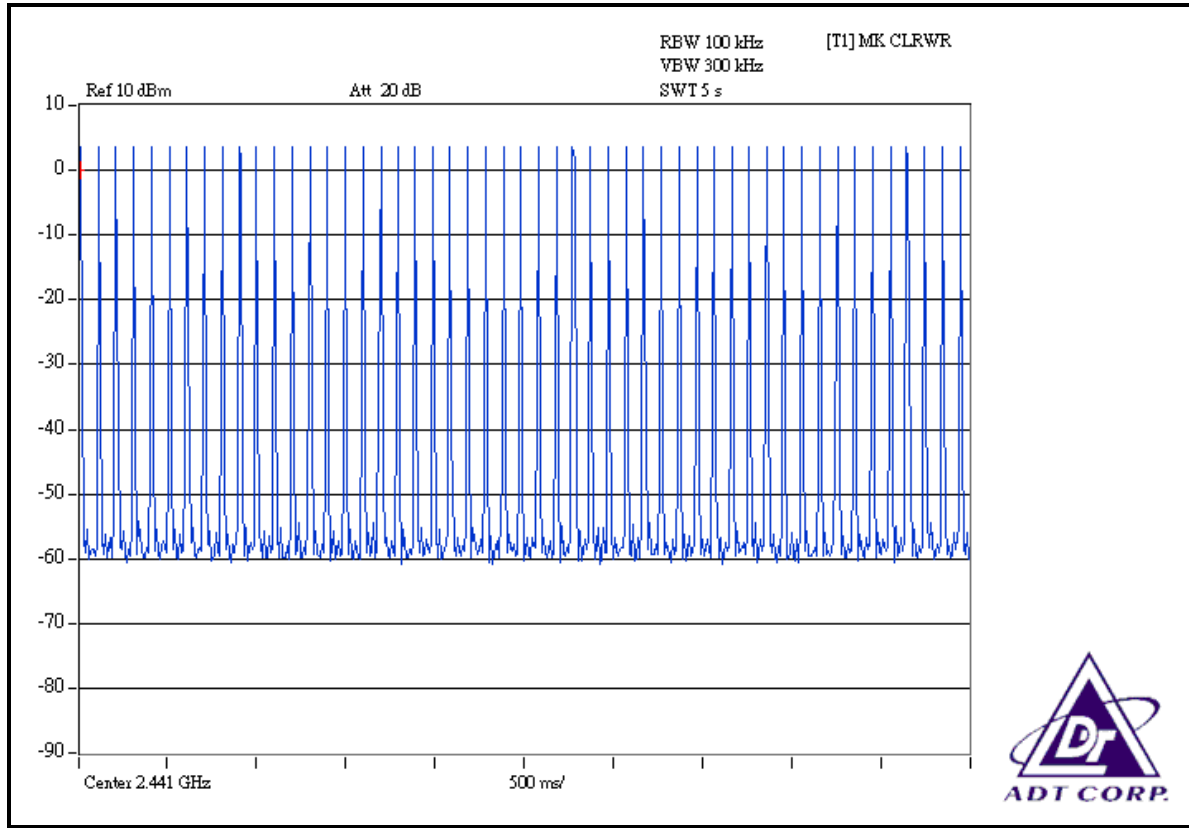

DH3

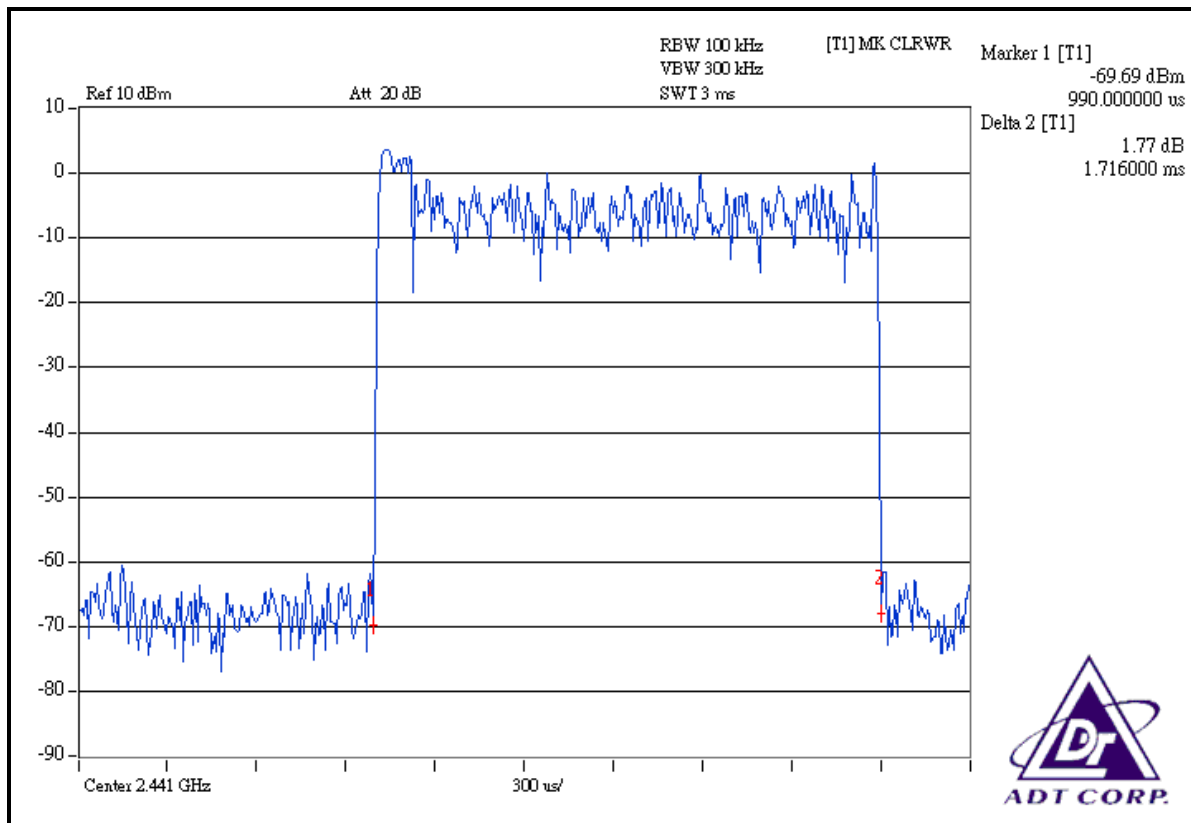
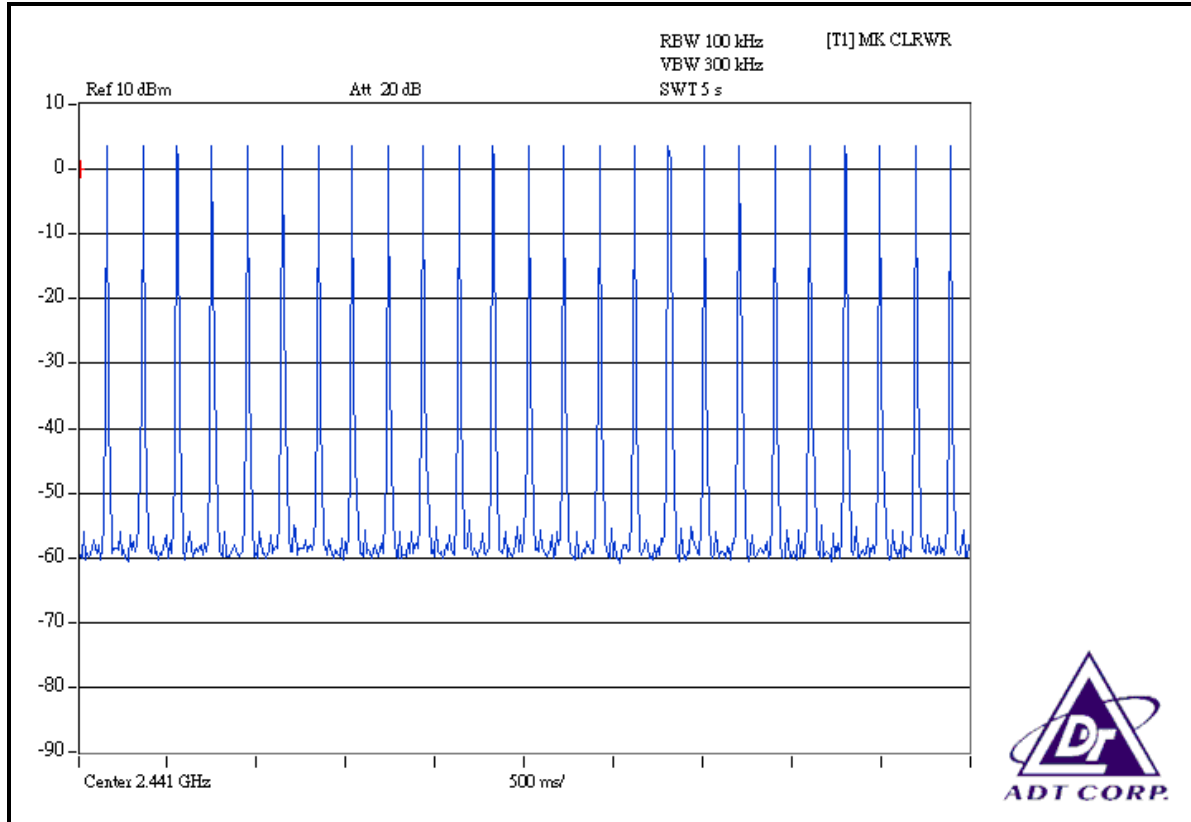

DH5

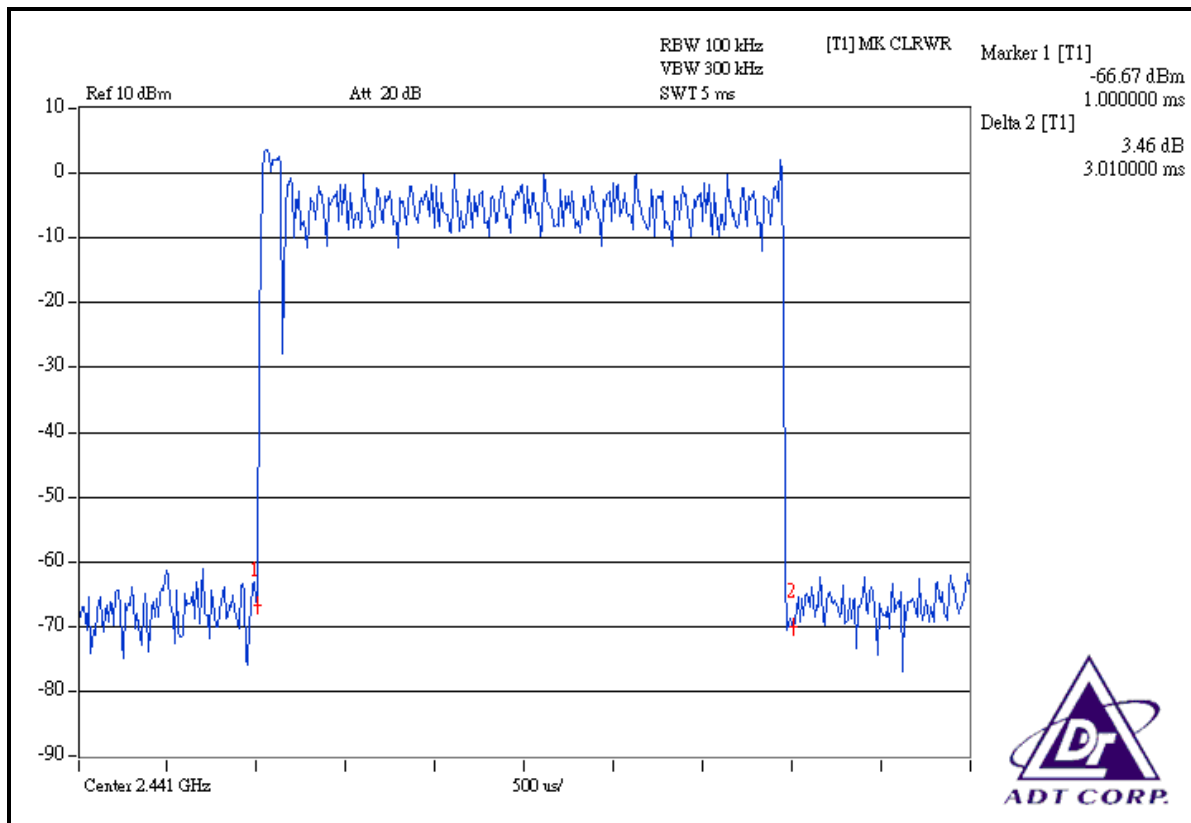
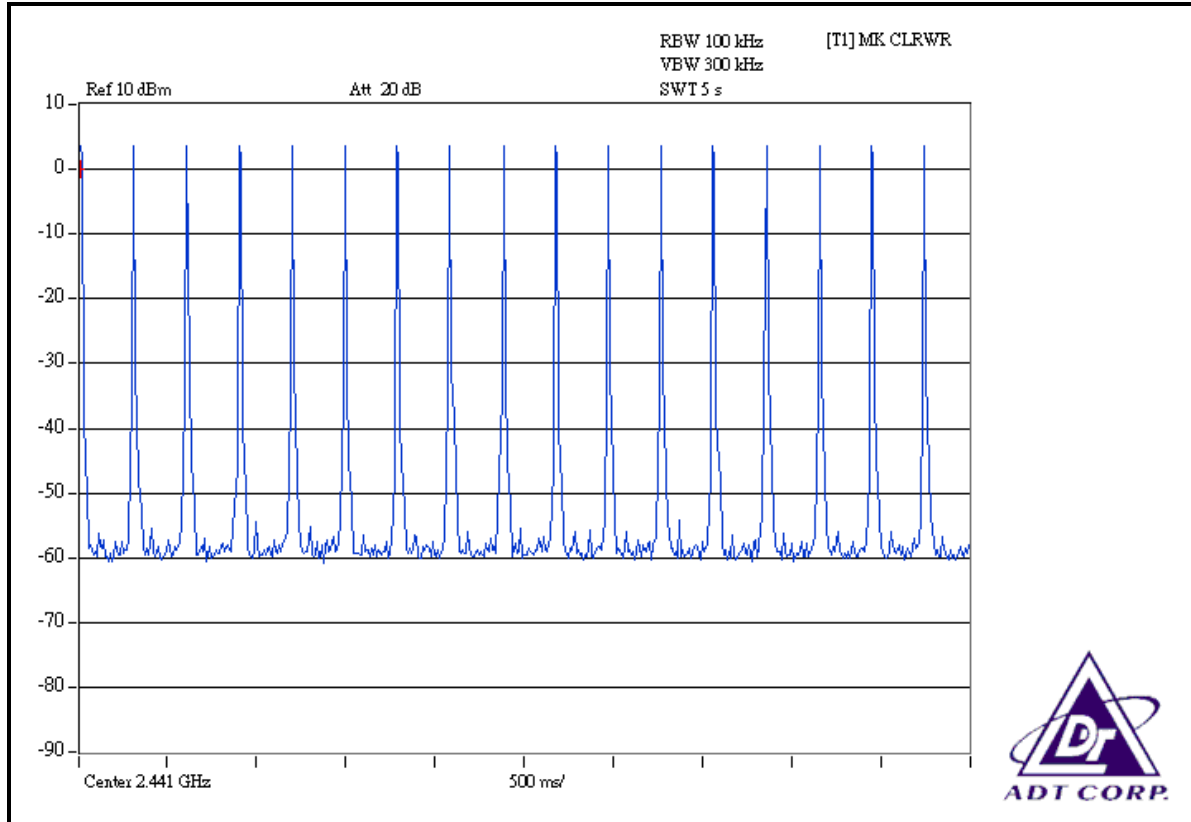



4.5 CHANNEL BANDWIDTH

4.5.1 LIMITS OF CHANNEL BANDWIDTH

For frequency hopping system operating in the 2400-2483.5MHz, If the 20dB bandwidth of hopping channel is greater than 25kHz, two-thirds 20dB bandwidth of hopping channel shall be a minimum limit for the hopping channel separation.

4.5.2 TEST INSTRUMENTS

DESCRIPTION & MANUFACTURER	MODEL NO.	SERIAL NO.	CALIBRATED UNTIL
SPECTRUM ANALYZER	FSP 40	100036	Mar. 12, 2009

NOTE: The calibration interval of the above test instruments is 12 months. And the calibrations are traceable to NML/ROC and NIST/USA.

4.5.3 TEST PROCEDURE

- a. Check the calibration of the measuring instrument using either an internal calibrator or a known signal from an external generator.
- b. Turn on the EUT and connect it to measurement instrument. Then set it to any one convenient frequency within its operating range. Set a reference level on the measuring instrument equal to the highest peak value.
- c. Measure the frequency difference of two frequencies that were attenuated 20dB from the reference level. Record the frequency difference as the emission bandwidth.
- d. Repeat above procedures until all frequencies measured were complete.

4.5.4 DEVIATION FROM TEST STANDARD

No deviation.

4.5.5 TEST SETUP

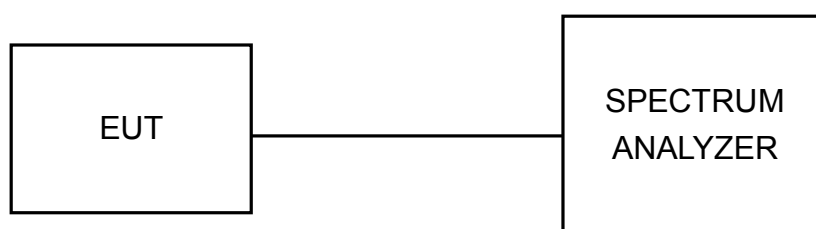

4.5.6 EUT OPERATING CONDITION

The software provided by client enabled the EUT to transmit and receive data at lowest, middle and highest channel frequencies individually.

4.5.7 TEST RESULTS

FOR GFSK

TEST MODE	A		
MODULATION TYPE	GFSK	CHANNEL	0, 39, 78
INPUT POWER	3.7Vdc	ENVIRONMENTAL CONDITIONS	20 deg. C, 70% RH, 1001hPa
TESTED BY	Jun Wu		

CHANNEL	CHANNEL FREQUENCY (MHz)	20dB BANDWIDTH (MHz)
0	2402	0.835
39	2441	0.830
78	2480	0.820

CH 0



CH 39



CH 78

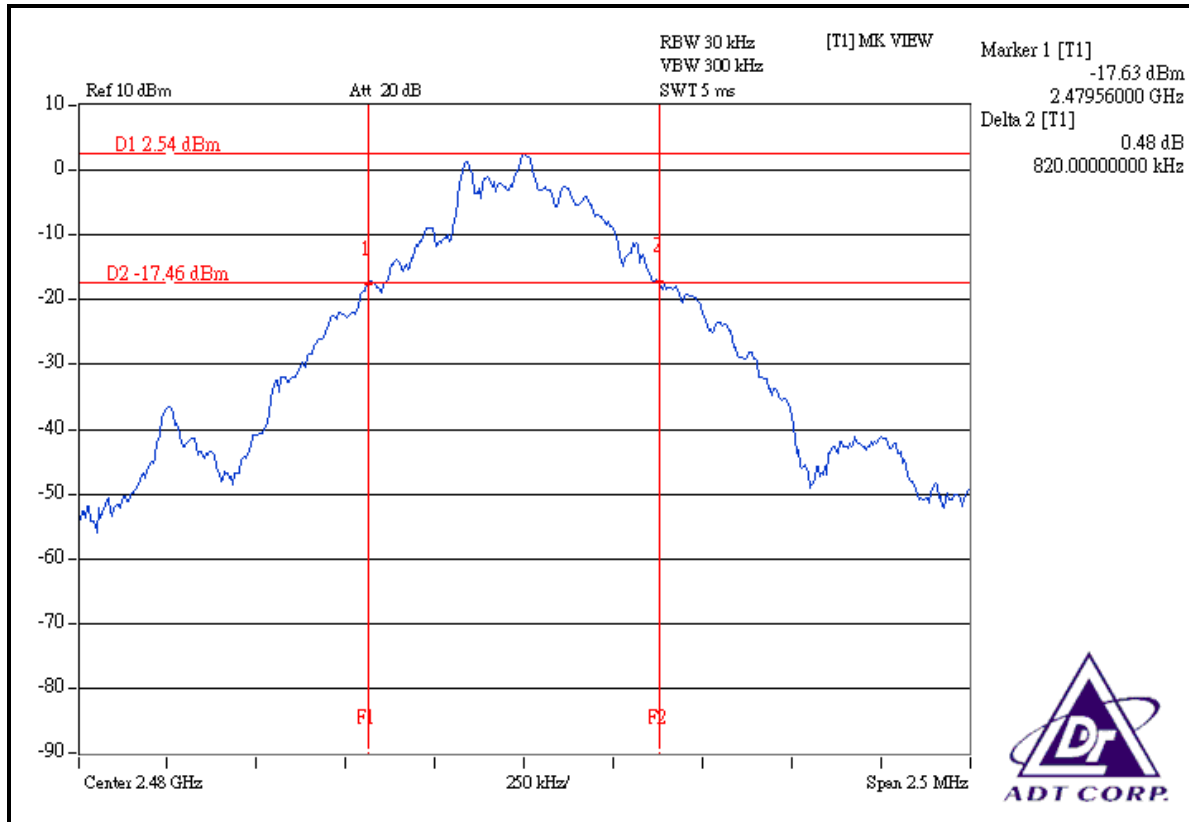

FOR 8DPSK

TEST MODE	A		
MODULATION TYPE	8DPSK	CHANNEL	0, 39, 78
INPUT POWER	3.7Vdc	ENVIRONMENTAL CONDITIONS	20 deg. C, 70% RH, 1001hPa
TESTED BY	Jun Wu		

CHANNEL	CHANNEL FREQUENCY (MHz)	20dB BANDWIDTH (MHz)
0	2402	1.260
39	2441	1.265
78	2480	1.255

CH 0

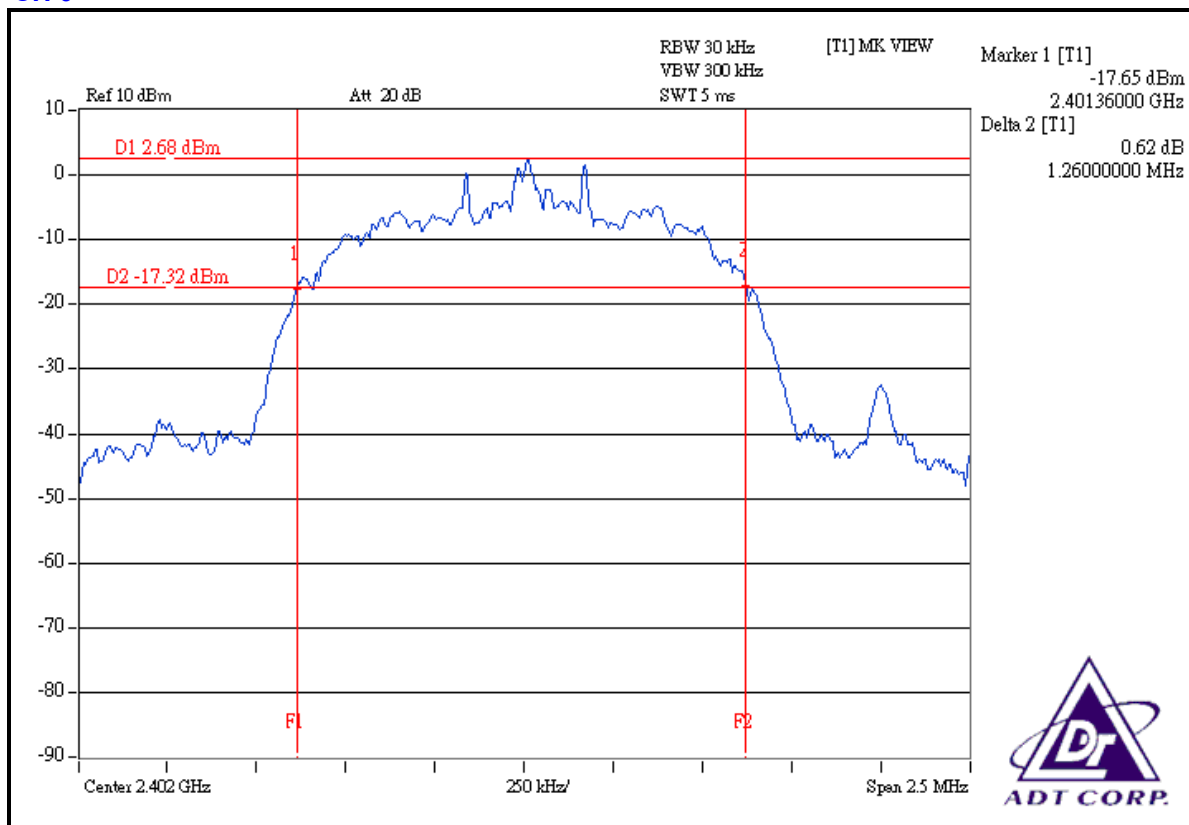

CH 39



CH 78

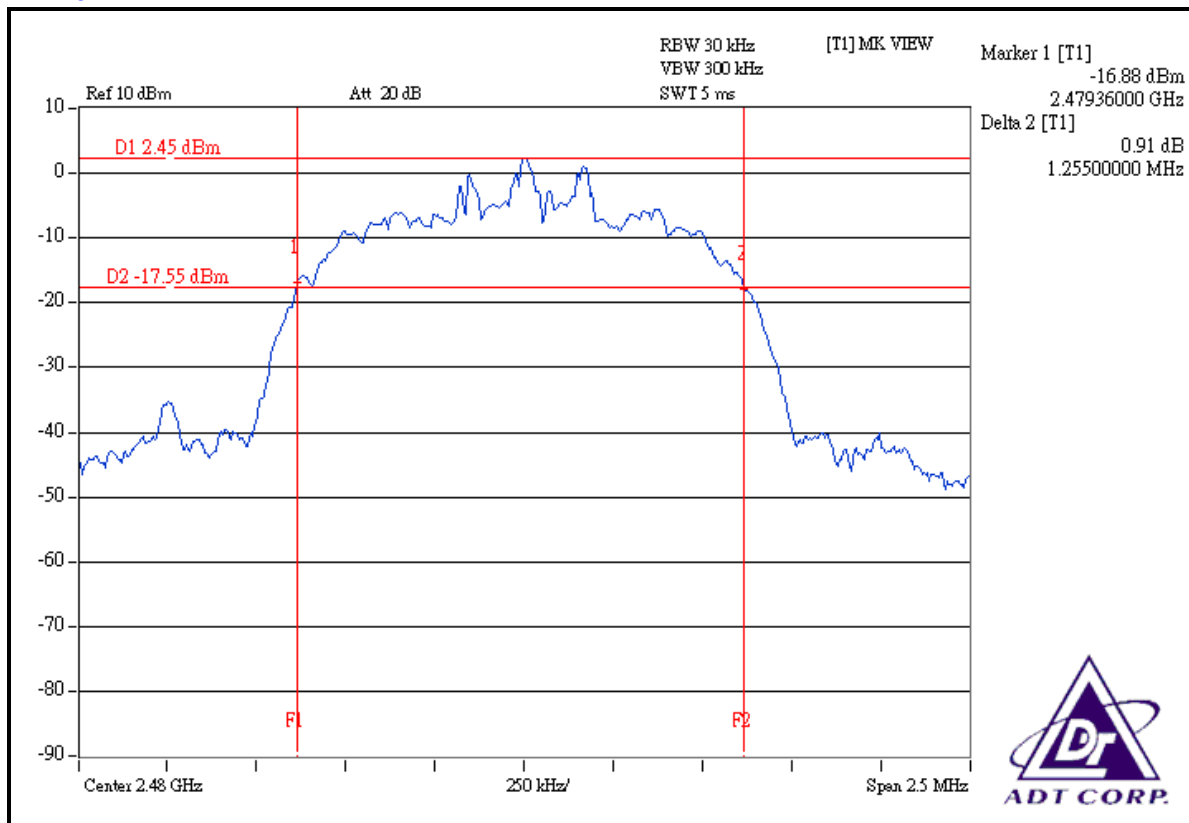



4.6 HOPPING CHANNEL SEPARATION

4.6.1 LIMIT OF HOPPING CHANNEL SEPARATION

At least 25kHz or two-third of 20dB hopping channel bandwidth (whichever is greater).

4.6.2 TEST INSTRUMENTS

DESCRIPTION & MANUFACTURER	MODEL NO.	SERIAL NO.	CALIBRATED UNTIL
SPECTRUM ANALYZER	FSP 40	100036	Mar. 12, 2009

NOTES: The calibration interval of the above test instruments is 12 months. And the calibrations are traceable to NML/ROC and NIST/USA.

4.6.3 TEST PROCEDURES

1. Check the calibration of the measuring instrument using either an internal calibrator or a known signal from an external generator.
2. Turn on the EUT and connect it to measurement instrument. Then set it to any one convenient frequency within its operating range.
3. By using the MaxHold function record the separation of two adjacent channels.
4. Measure the frequency difference of these two adjacent channels by SA MARK function. And then plot the result on SA screen.
5. Repeat above procedures until all frequencies measured were complete.

4.6.4 DEVIATION FROM TEST STANDARD

No deviation.

4.6.5 TEST SETUP

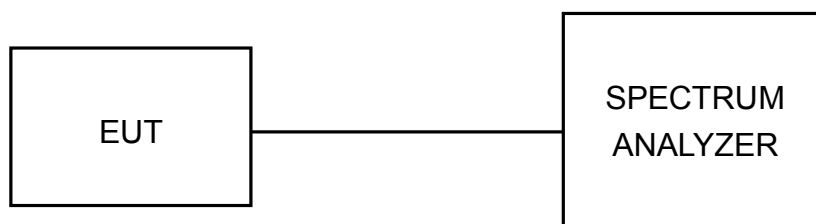

4.6.6 TEST RESULTS

FOR GFSK

TEST MODE	A		
MODULATION TYPE	GFSK	CHANNEL	0, 39, 78
INPUT POWER	3.7Vdc	ENVIRONMENTAL CONDITIONS	20 deg. C, 70% RH, 1001hPa
TESTED BY	Jun Wu		

CHANNEL	FREQUENCY (MHz)	ADJACENT CHANNEL SEPARATION (MHz)	20dB BANDWIDTH (MHz)	MINIMUM LIMIT (MHz)	PASS / FAIL
0	2402	1.002	0.835	0.557	PASS
39	2441	1.003	0.830	0.553	PASS
78	2480	1.006	0.820	0.547	PASS

NOTE: The minimum limit is two-third 20dB bandwidth. Test results please refer to next two pages.

CH 0

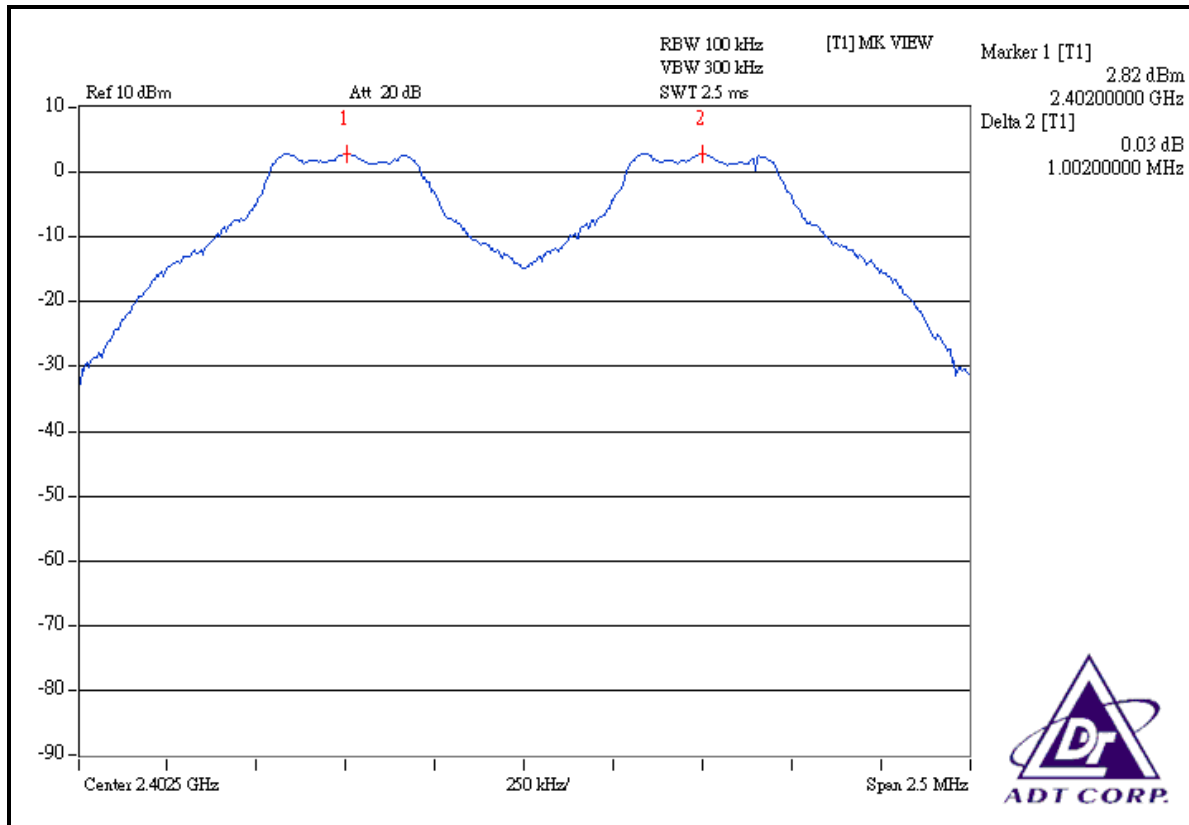

CH 39

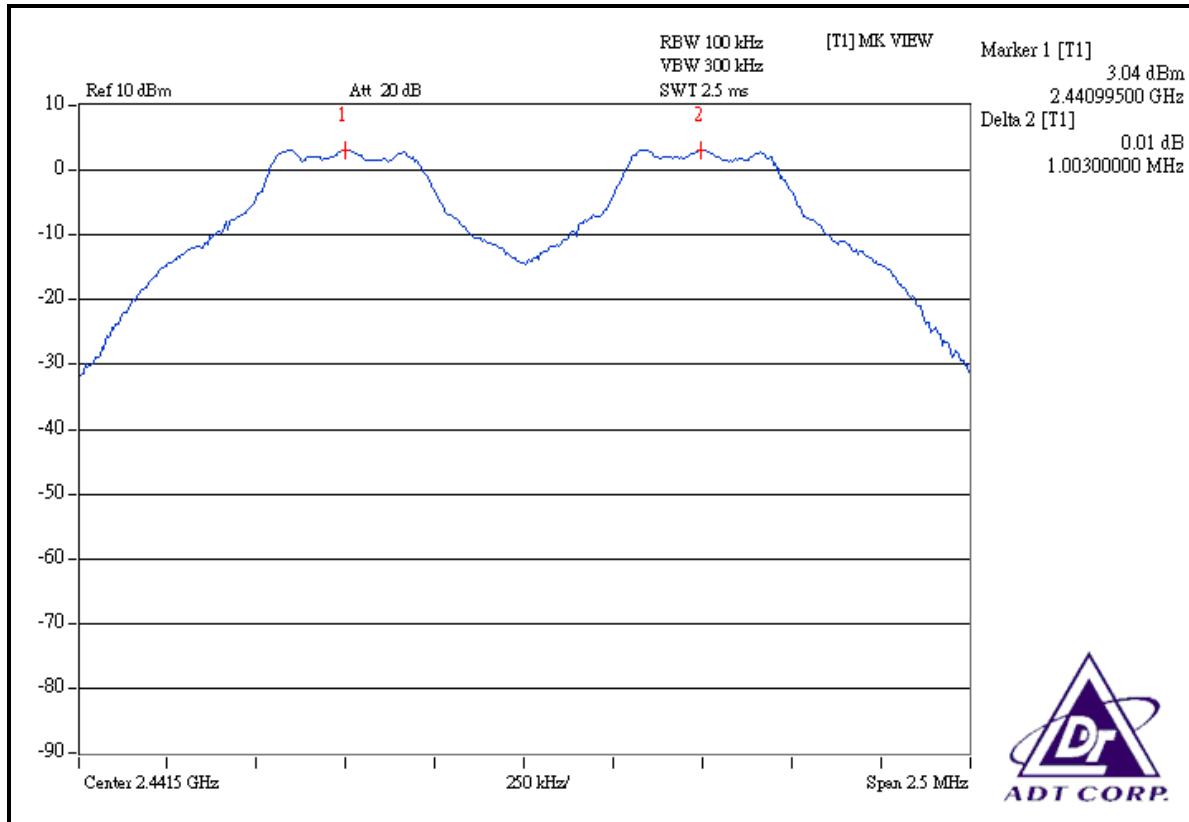

CH 78

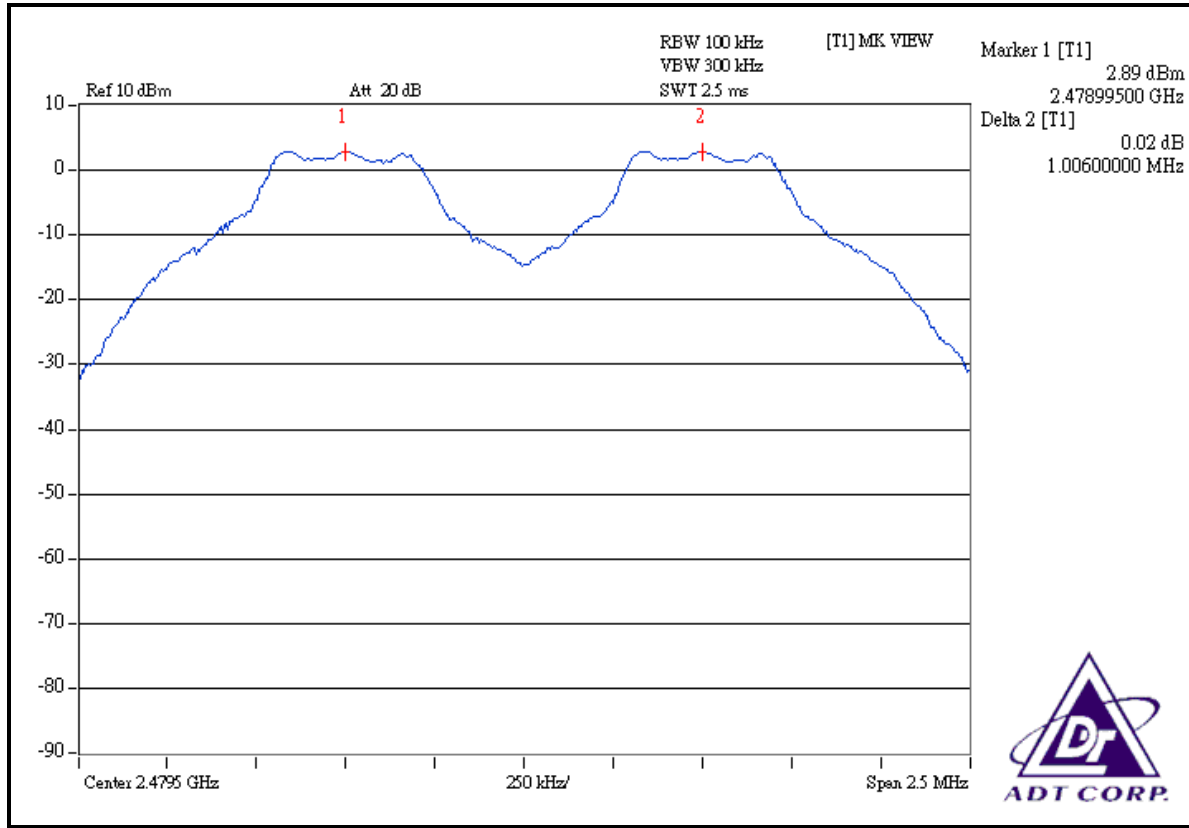

FOR 8DPSK

TEST MODE	A		
MODULATION TYPE	8DPSK	CHANNEL	0, 39, 78
INPUT POWER	3.7Vdc	ENVIRONMENTAL CONDITIONS	20 deg. C, 70% RH, 1001hPa
TESTED BY	Jun Wu		

CHANNEL	FREQUENCY (MHz)	ADJACENT CHANNEL SEPARATION (MHz)	20dB BANDWIDTH (MHz)	MINIMUM LIMIT (MHz)	PASS / FAIL
0	2402	1.002	1.260	0.840	PASS
39	2441	1.002	1.265	0.843	PASS
78	2480	1.005	1.265	0.843	PASS

NOTE: The minimum limit is two-third 20dB bandwidth. Test results please refer to following three plots.

CH 0

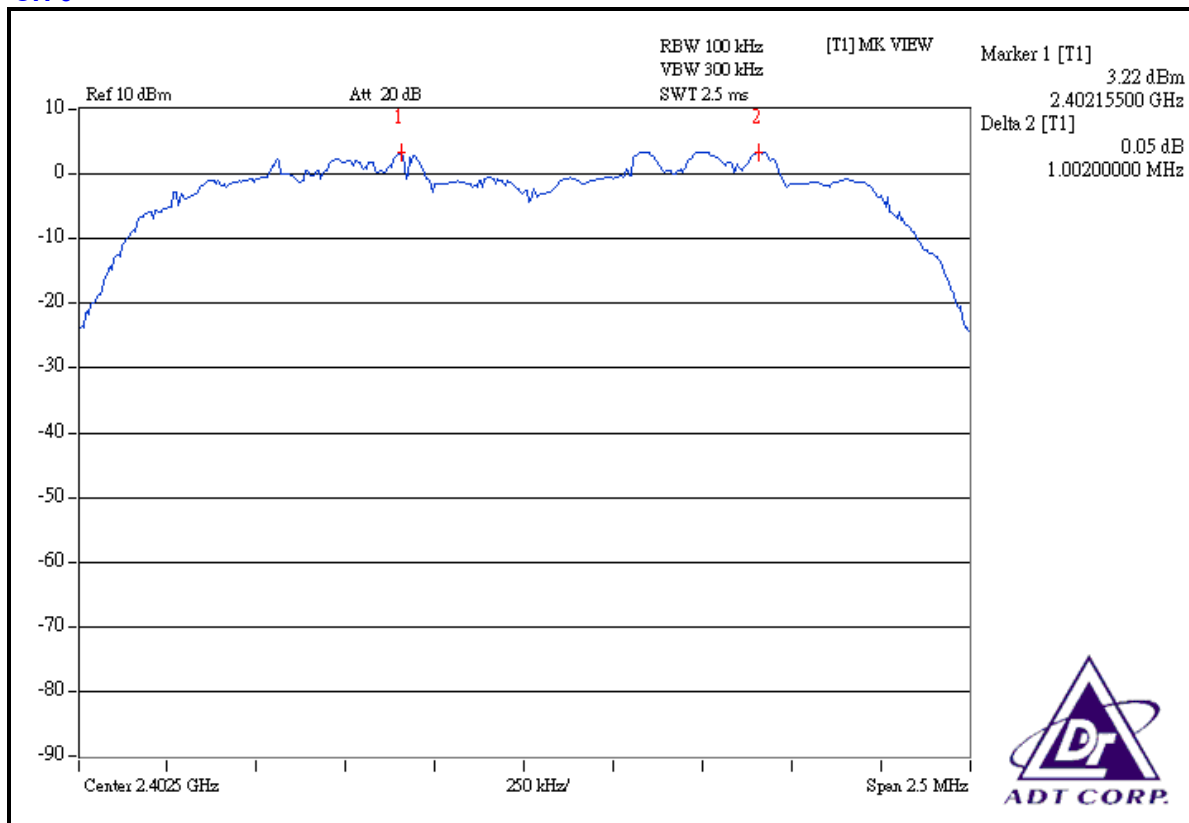

CH 39

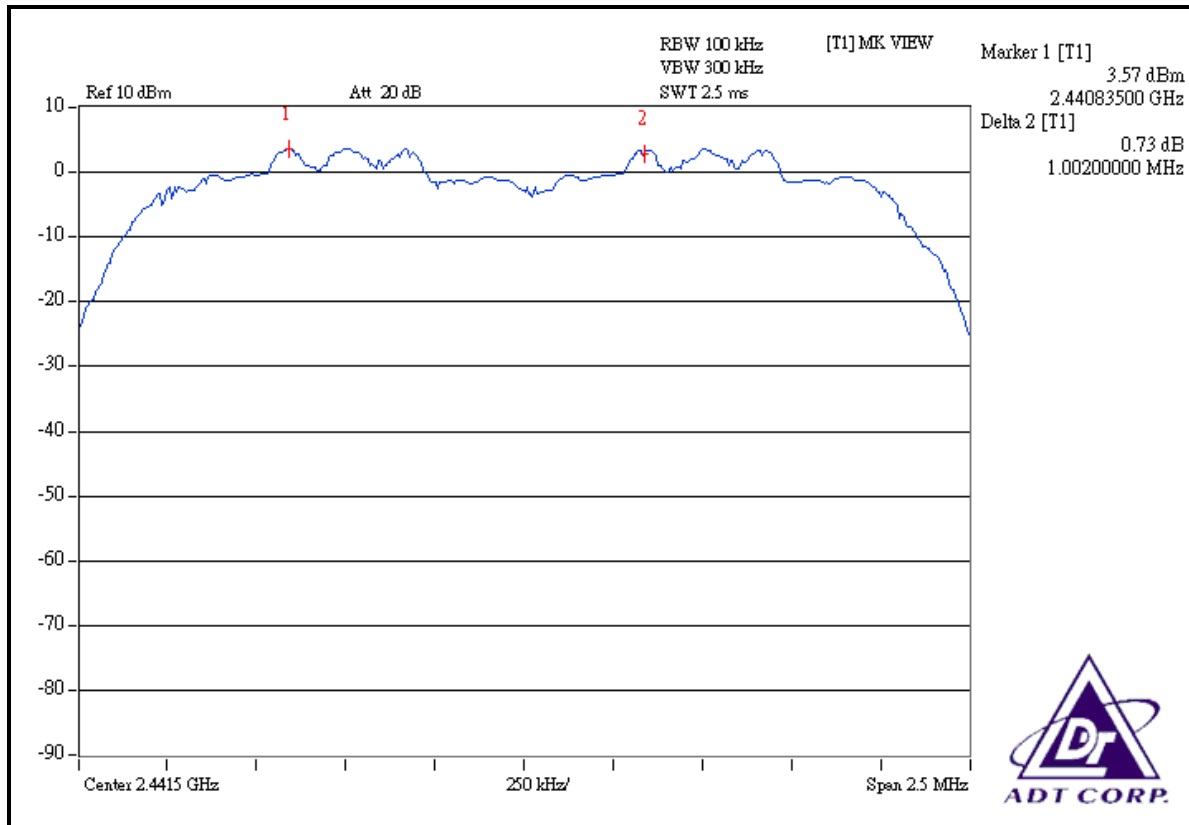

CH 78

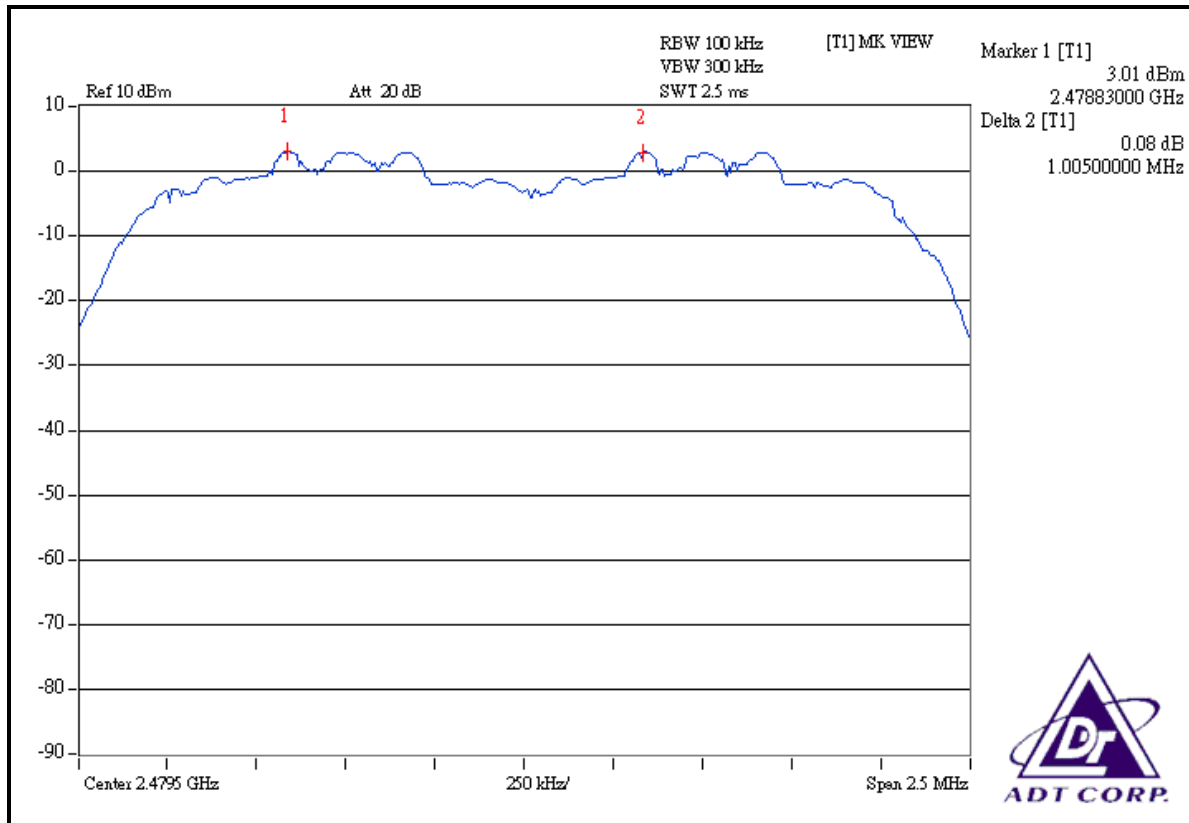



4.7 MAXIMUM PEAK OUTPUT POWER

4.7.1 LIMITS OF MAXIMUM PEAK OUTPUT POWER MEASUREMENT

The Maximum Peak Output Power Measurement is 125mW.

4.7.2 TEST INSTRUMENTS

DESCRIPTION & MANUFACTURER	MODEL NO.	SERIAL NO.	CALIBRATED UNTIL
SPECTRUM ANALYZER	FSP 40	100036	Mar. 12, 2009

NOTE: The calibration interval of the above test instruments is 12 months and the calibrations are traceable to NML/ROC and NIST/USA.

4.7.3 TEST PROCEDURES

- a. Check the calibration of the measuring instrument using either an internal calibrator or a known signal from an external generator.
- b. Turn on the EUT and connect it to measurement instrument. Then set it to any one convenient frequency within its operating range. Set a reference level on the measuring instrument equal to the highest peak value.
- c. The center frequency of the spectrum analyzer is set to the fundamental frequency and using 3MHz RBW and 10 MHz VBW.
- d. Measure the captured power within the band and recording the plot.
- e. Repeat above procedures until all frequencies required were complete.

4.7.4 DEVIATION FROM TEST STANDARD

No deviation

4.7.5 TEST SETUP

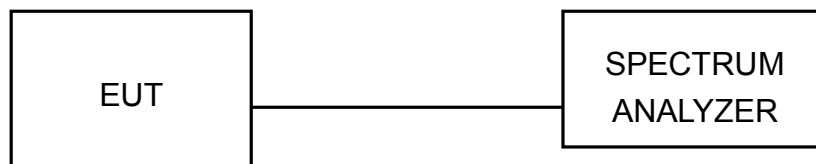

For the actual test configuration, please refer to the related Item – Photographs of the Test Configuration.

4.7.6 EUT OPERATING CONDITION

The software provided by client enabled the EUT to transmit and receive data at lowest, middle and highest channel frequencies individually.

4.7.7 TEST RESULTS

FOR GFSK

TEST MODE	A		
MODULATION TYPE	GFSK	CHANNEL	0, 39, 78
INPUT POWER	3.7Vdc	ENVIRONMENTAL CONDITIONS	20 deg. C, 70% RH, 1001hPa
TESTED BY	Jun Wu		

CHANNEL	CHANNEL FREQUENCY (MHz)	PEAK POWER OUTPUT (dBm)	PEAK POWER OUTPUT (mW)	PEAK POWER LIMIT (mW)	PASS/FAIL
0	2402	2.92	1.959	125	PASS
39	2441	3.13	2.056	125	PASS
78	2480	2.95	1.972	125	PASS

CH 0

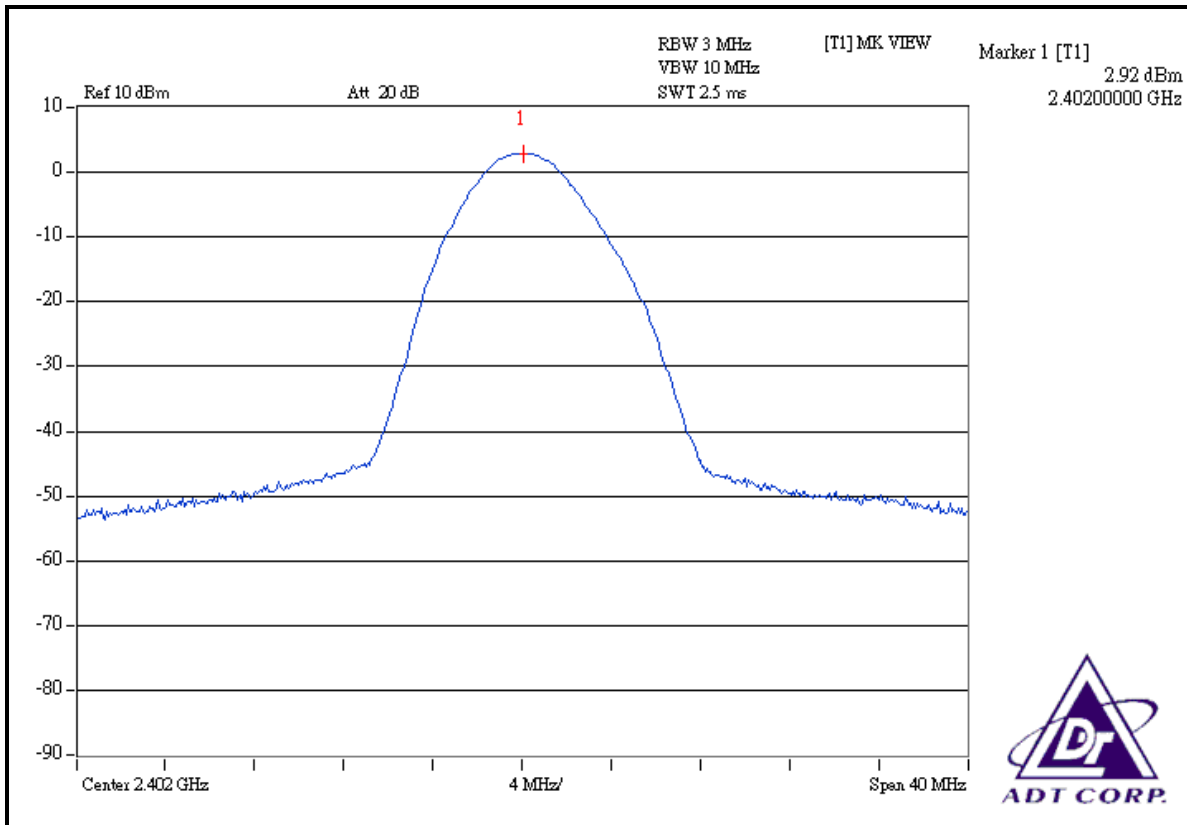

CH 39

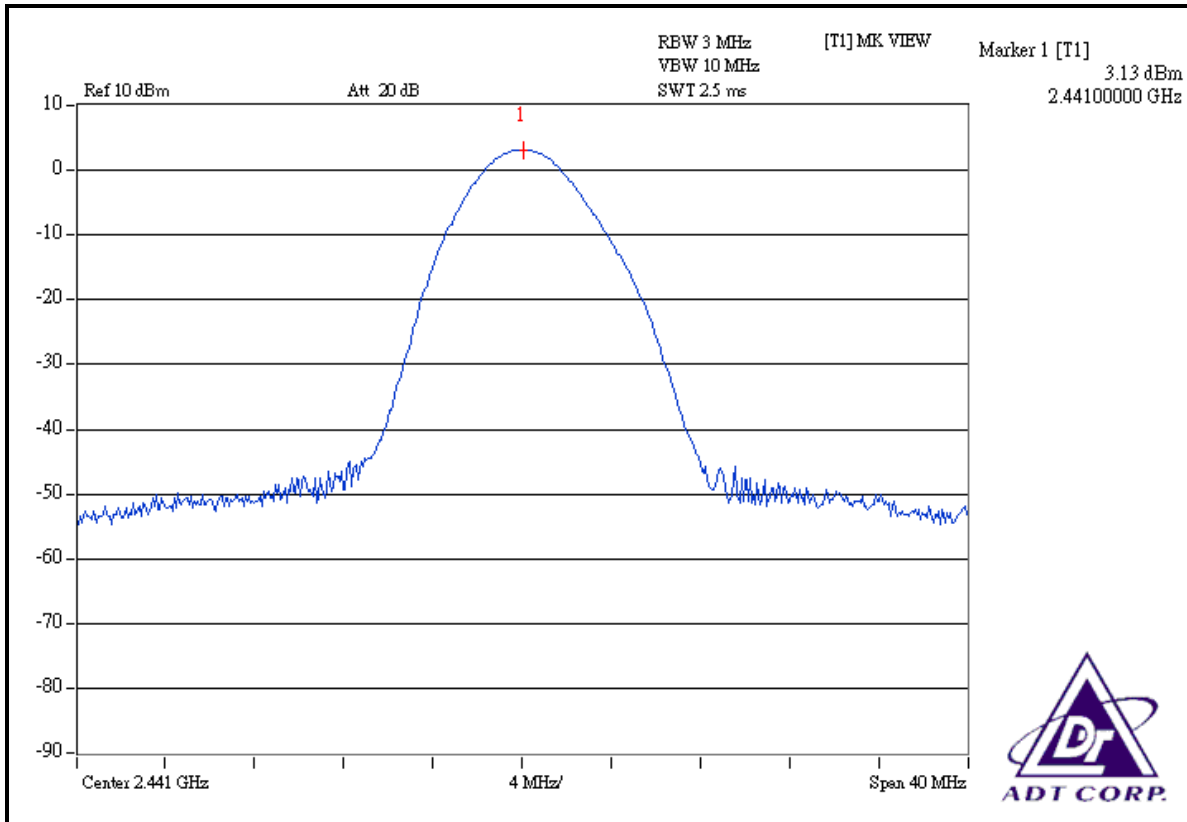

CH 78

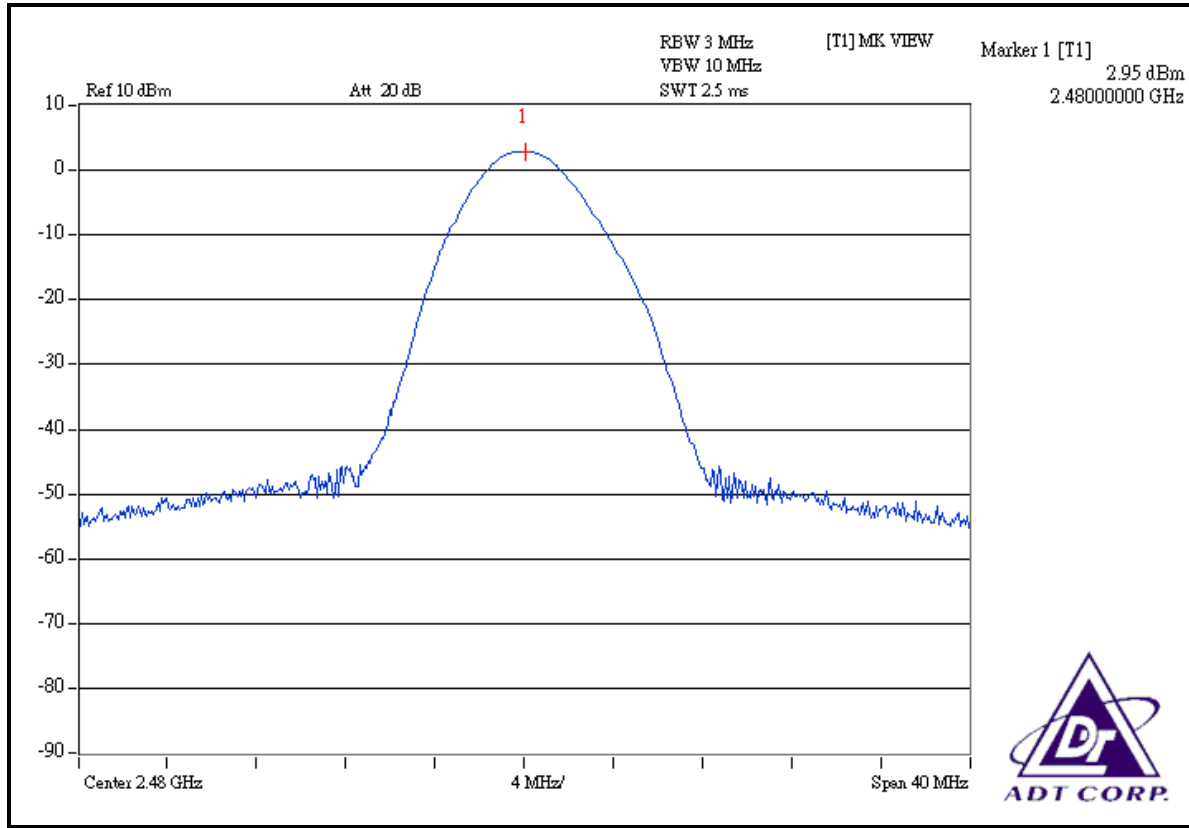



CH 39

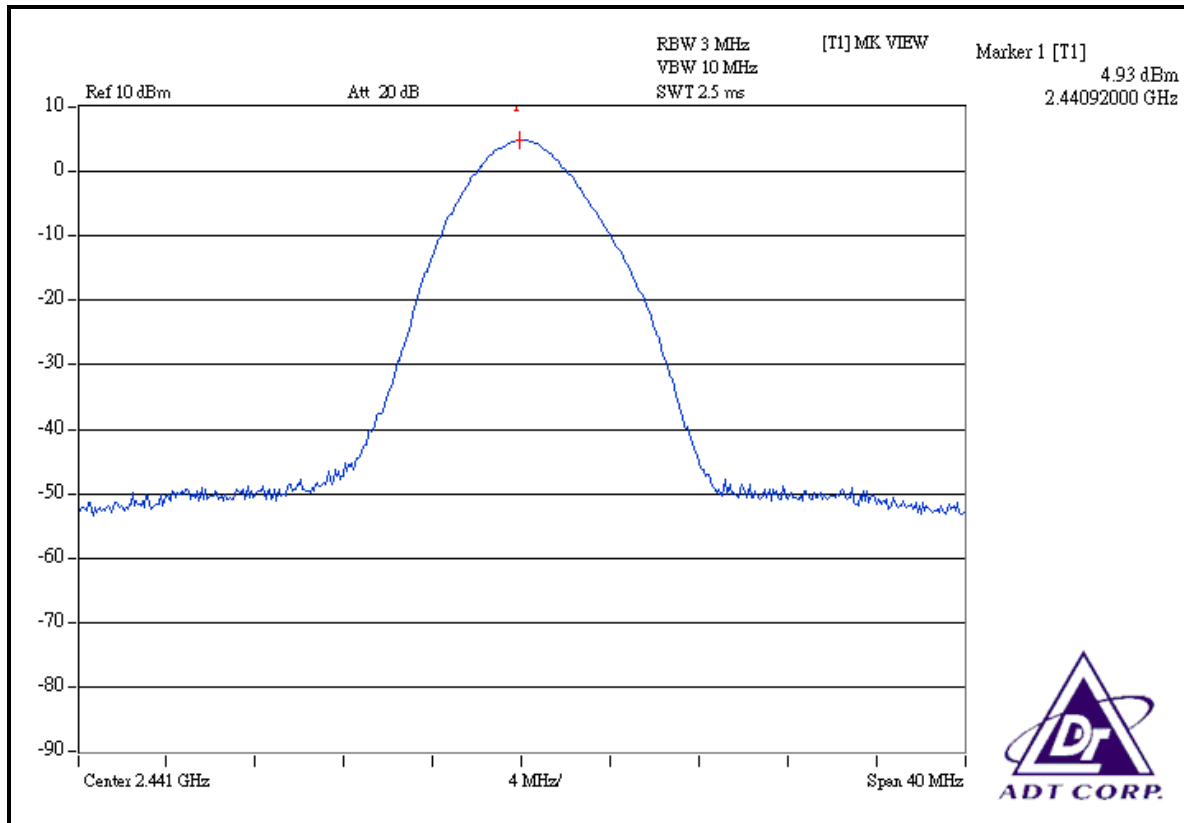

CH 78

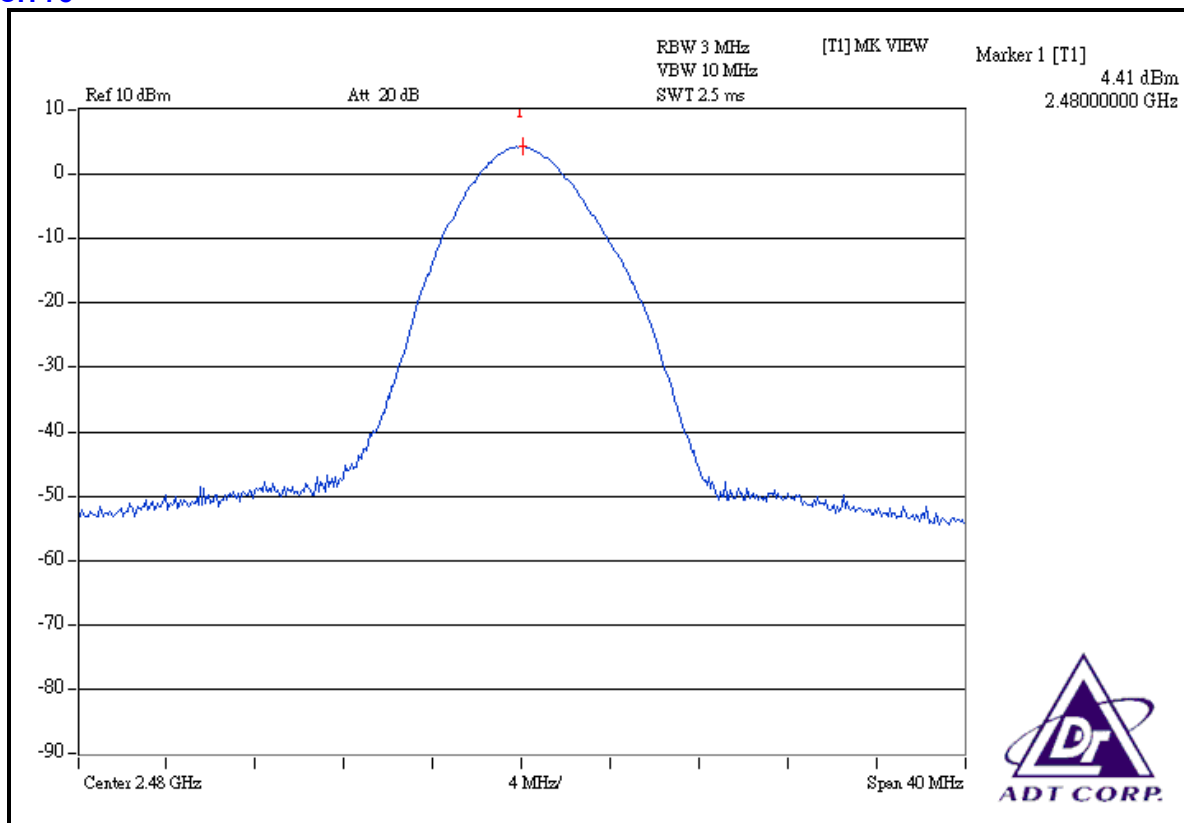



4.8 BAND EDGES MEASUREMENT

4.8.1 LIMITS OF BAND EDGES MEASUREMENT

Below -20dB of the highest emission level of operating band (in 100KHz RBW).

4.8.2 TEST INSTRUMENTS

DESCRIPTION & MANUFACTURER	MODEL NO.	SERIAL NO.	CALIBRATED UNTIL
SPECTRUM ANALYZER	FSP 40	100036	Mar. 12, 2009

NOTES: The calibration interval of the above test instruments is 12 months. And the calibrations are traceable to NML/ROC and NIST/USA.

4.8.3 TEST PROCEDURE

The transmitter output was connected to the spectrum analyzer via a low lose cable. Set both RBW and VBW of spectrum analyzer to 100 kHz and 300 kHz with suitable frequency span including 100 MHz bandwidth from band edge. The band edges was measured and recorded.

The spectrum plots are attached on the following pages.

4.8.4 DEVIATION FROM TEST STANDARD

No deviation.

4.8.5 EUT OPERATING CONDITION

The software provided by client enabled the EUT to transmit and receive data at lowest, middle and highest channel frequencies individually.

4.8.6 TEST RESULTS

The spectrum plots are attached on the following 8 images. D1 line indicates the highest level, D2 line indicates the 20dB offset below D1. It shows compliance with the requirement in part 15.247(d).

Mode A: FOR GFSK

NOTE 1:

The band edge emission plot on the next page shows 60.95dBc between carrier maximum power and local maximum emission in restrict band (2.3766GHz). The emission of carrier strength list in the test result of channel 0 at the item 4.2.7 is 104.79dBuV/m (Peak), so the maximum field strength in restrict band is $104.79 - 60.95 = 43.84$ dBuV/m, which is under 74 dBuV/m limit.

Average value = $43.84 - 30.10 = 13.74$ dBuV/m, which is under 54dBuV/m limit.

*The DH5 packet was the worse case duty cycle for a transmit dwell time on a channel, based upon bluetooth theory the transmitter is on $0.625 * 5$ per 296.25 ms per channel. Therefore, the duty cycle be equal to: $20\log(3.125/100) = -30.1$ dB.

Average value = peak reading -30.10 .

NOTE 2:

The band edge emission plot on the next second page shows 58.92dBc between carrier maximum power and local maximum emission in restrict band (2.4838GHz). The emission of carrier strength list in the test result of channel 78 at the item 4.2.7 is 107.21dBuV/m (Peak), so the maximum field strength in restrict band is $107.21 - 58.92 = 48.29$ dBuV/m, which is under 74 dBuV/m limit.

Average value = $48.29 - 30.10 = 18.19$ dBuV/m, which is under 54dBuV/m limit.

*The DH5 packet was the worse case duty cycle for a transmit dwell time on a channel, based upon bluetooth theory the transmitter is on $0.625 * 5$ per 296.25 ms per channel. Therefore, the duty cycle be equal to: $20\log(3.125/100) = -30.1$ dB.

Average value = peak reading -30.10 .

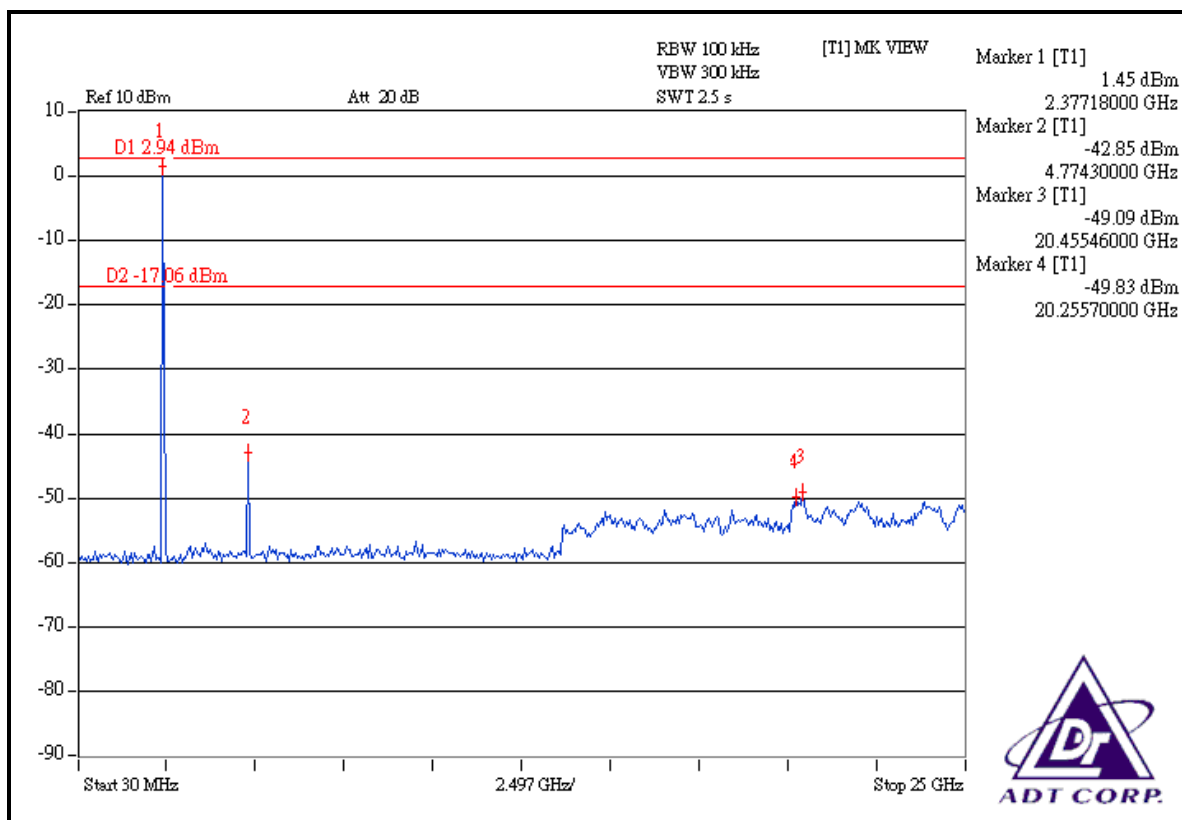
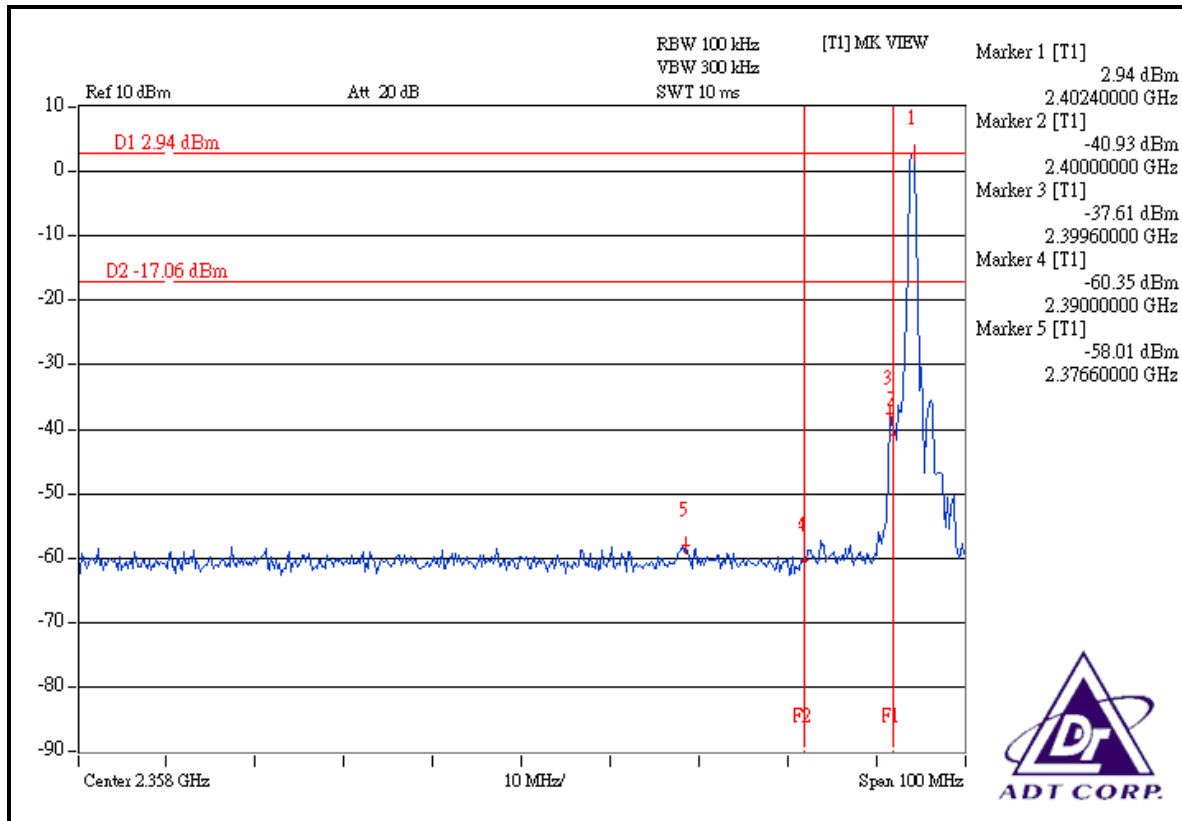

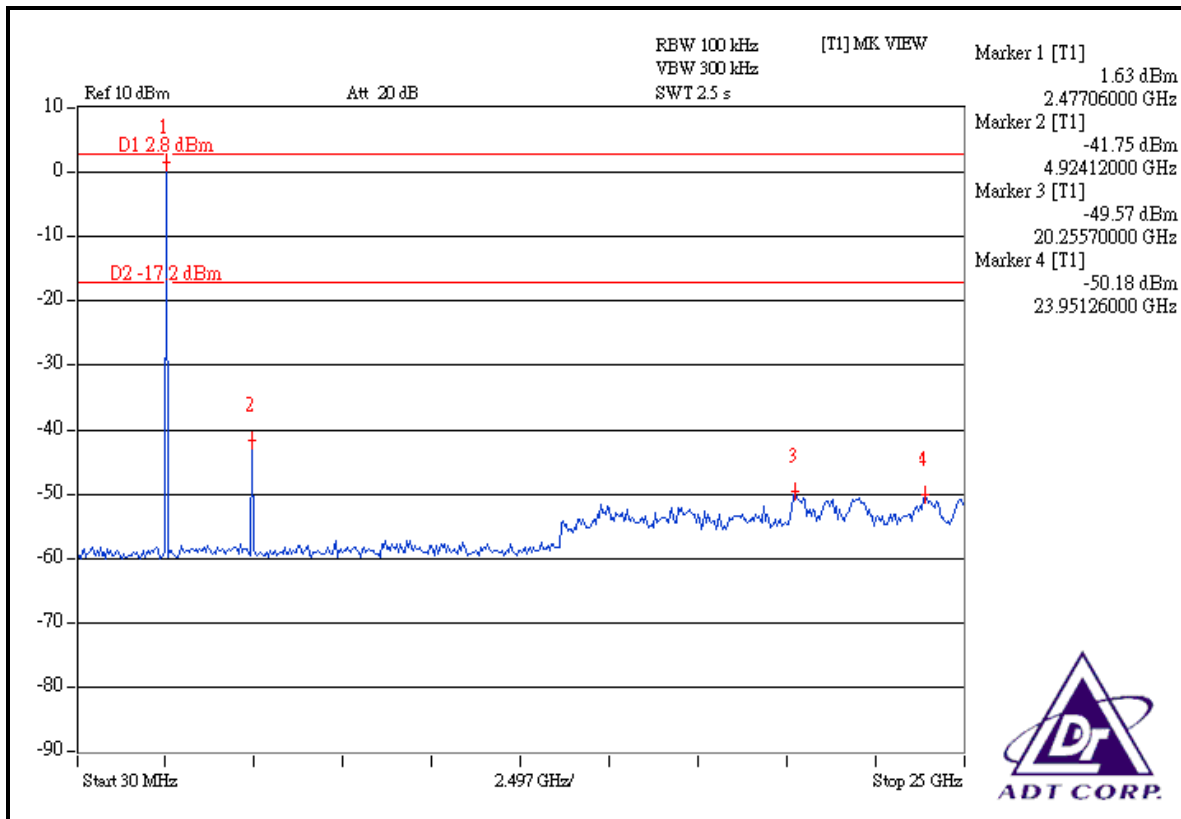
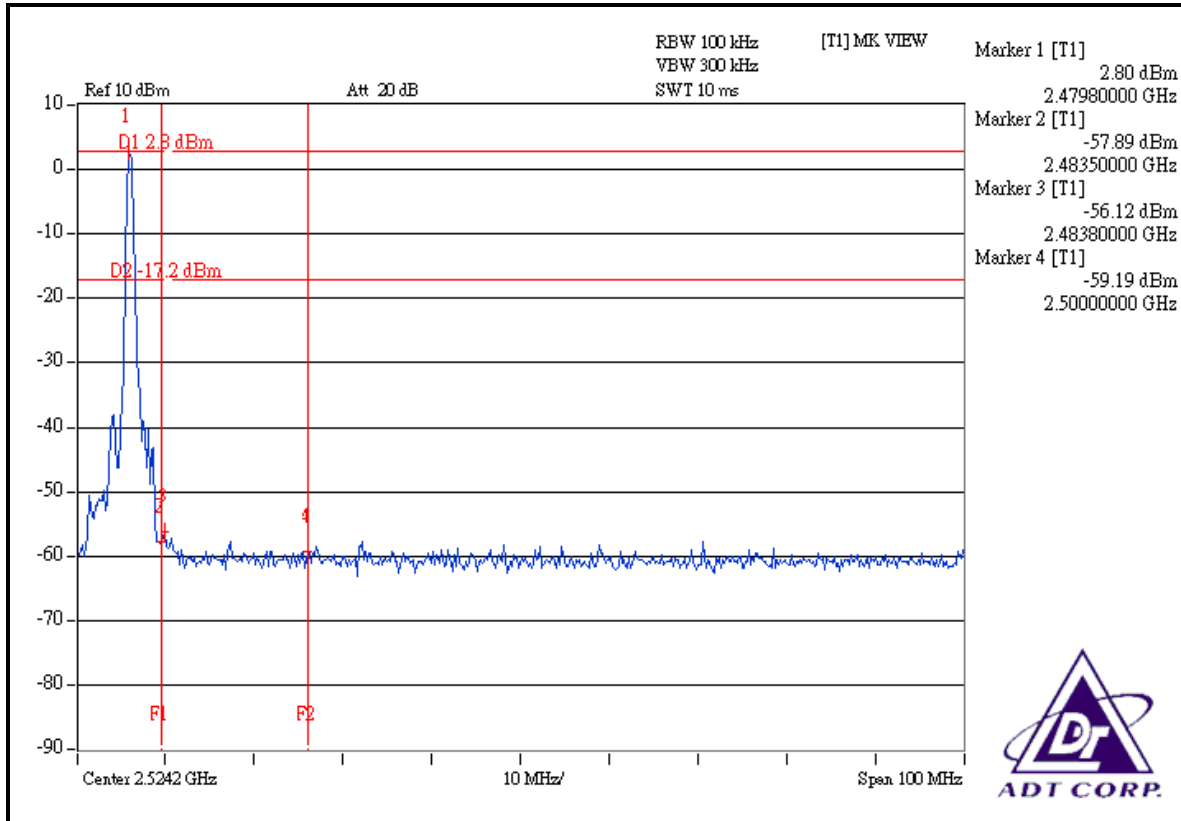

Mode A: FOR 8DPSK

NOTE 1:

The band edge emission plot on the next page shows 59.76dBc between carrier maximum power and local maximum emission in restrict band (2.3762GHz). The emission of carrier strength list in the test result of channel 0 at the item 4.2.7 is 106.21dBuV/m (Peak), so the maximum field strength in restrict band is $106.21 - 59.76 = 46.45$ dBuV/m, which is under 74 dBuV/m limit.

Average value = $46.45 - 30.10 = 16.35$ dBuV/m, which is under 54dBuV/m limit.

*The DH5 packet was the worse case duty cycle for a transmit dwell time on a channel, based upon bluetooth theory the transmitter is on $0.625 * 5$ per 296.25 ms per channel. Therefore, the duty cycle be equal to: $20\log(3.125/100) = -30.1$ dB.

Average value = peak reading -30.10 .

NOTE 2:

The band edge emission plot on the next second page shows 57.90dBc between carrier maximum power and local maximum emission in restrict band (2.4835GHz). The emission of carrier strength list in the test result of channel 78 at the item 4.2.7 is 104.12dBuV/m (Peak), so the maximum field strength in restrict band is $104.12 - 57.90 = 46.22$ dBuV/m, which is under 74 dBuV/m limit.

Average value = $46.22 - 30.10 = 16.12$ dBuV/m, which is under 54dBuV/m limit.

*The DH5 packet was the worse case duty cycle for a transmit dwell time on a channel, based upon bluetooth theory the transmitter is on $0.625 * 5$ per 296.25 ms per channel. Therefore, the duty cycle be equal to: $20\log(3.125/100) = -30.1$ dB.

Average value = peak reading -30.10 .

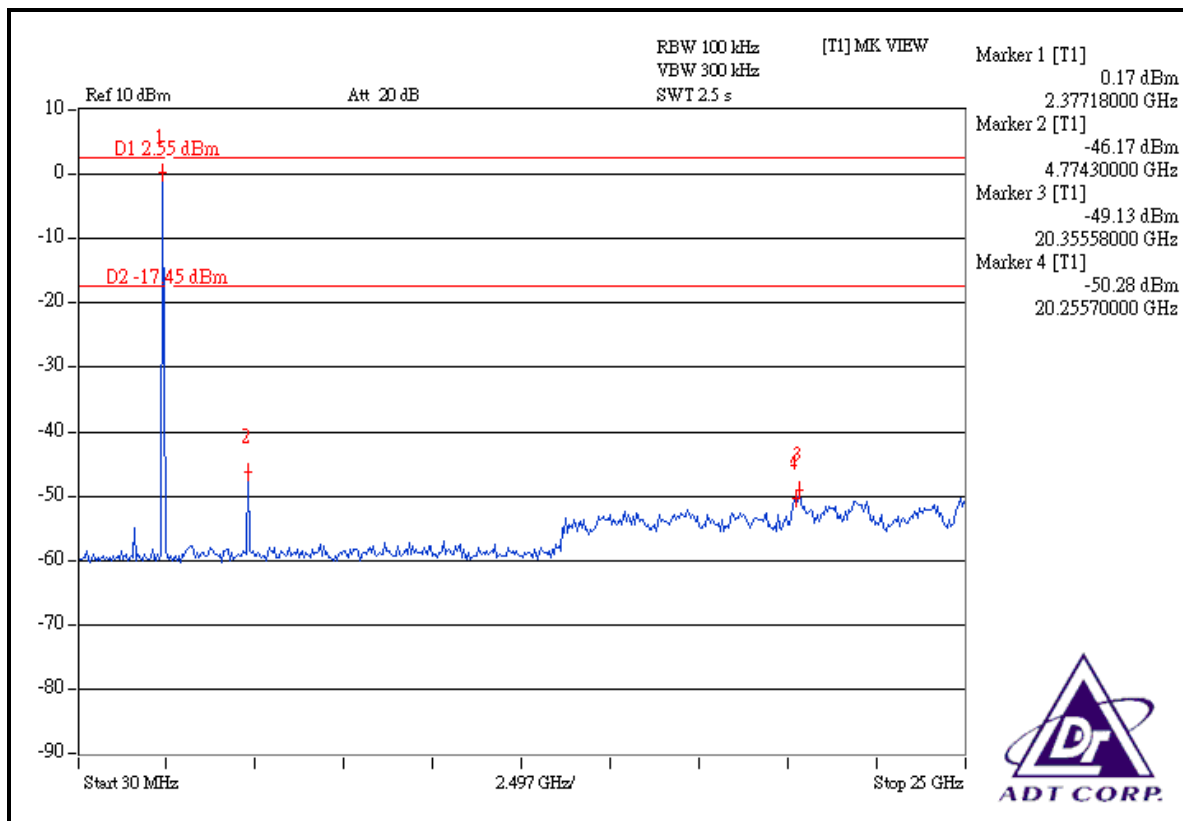
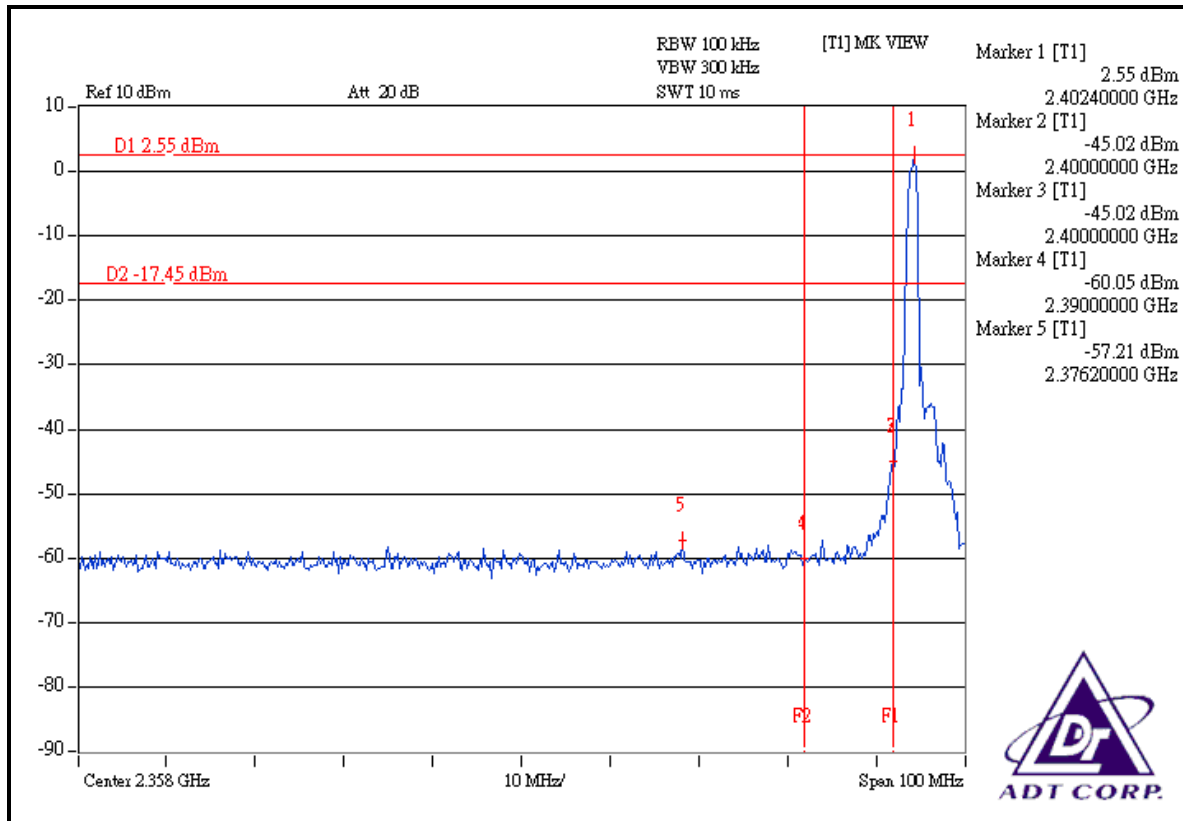

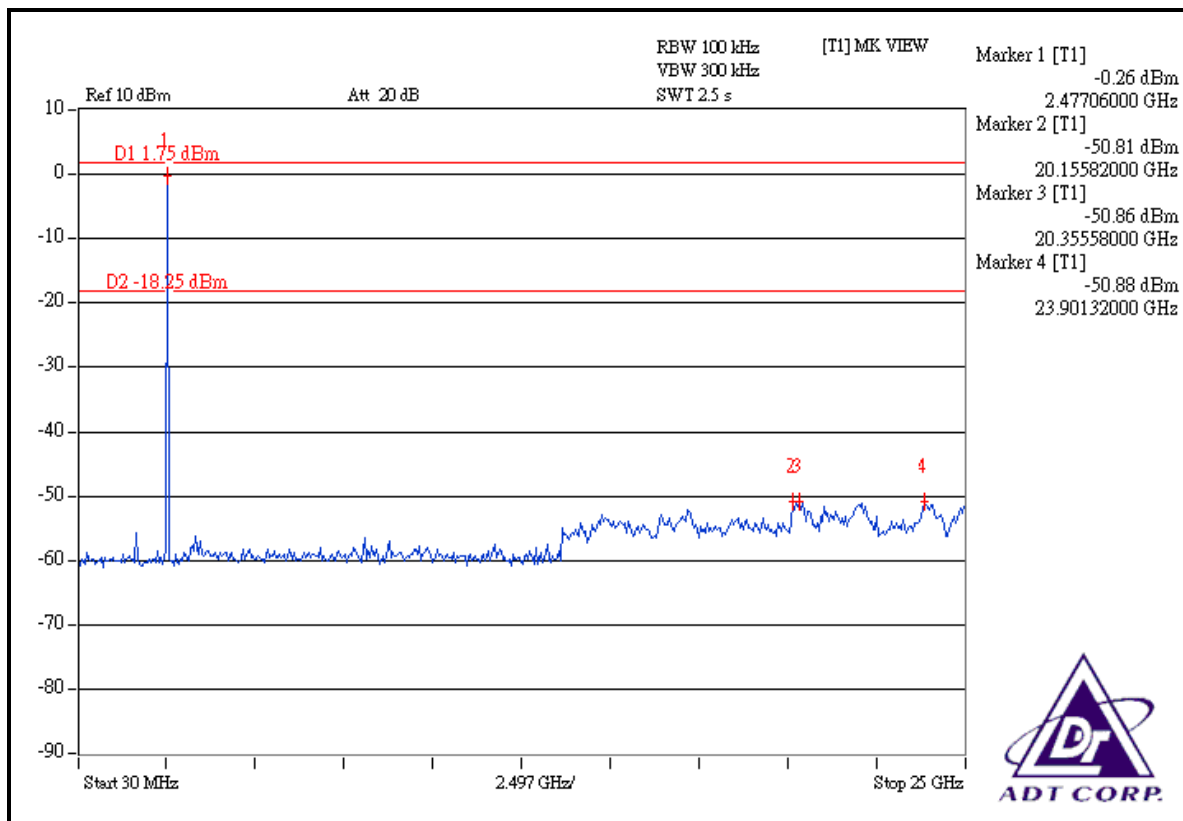
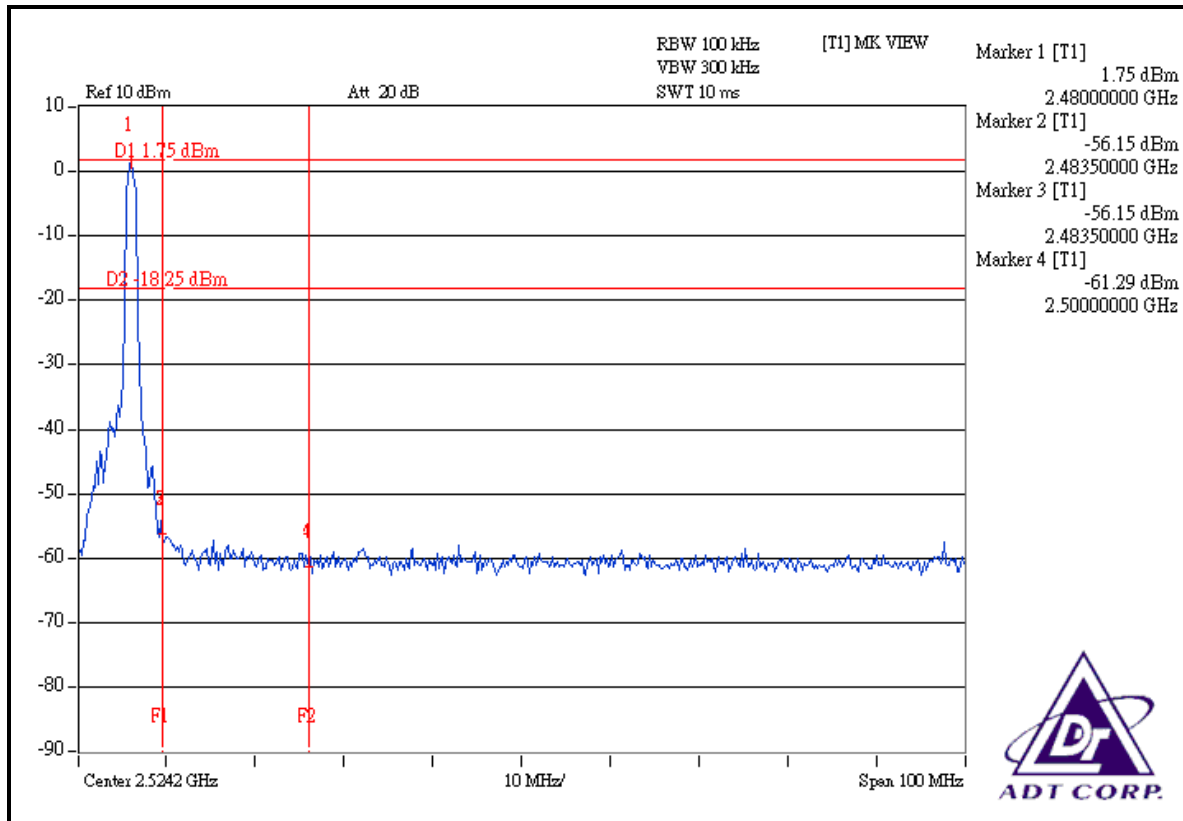



4.9 ANTENNA REQUIREMENT

4.9.1 STANDARD APPLICABLE

For intentional device, according to FCC 47 CFR Section 15.203, an intentional radiator shall be designed to ensure that no antenna other than that furnished by the responsible party shall be used with the device.

And according to FCC 47 CFR Section 15.247 (b), if transmitting antennas of directional gain greater than 6 dBi are used, the power shall be reduced by the amount in dB that the directional gain of the antenna exceeds 6 dBi.

4.9.2 ANTENNA CONNECTED CONSTRUCTION

The antenna used in this product is Chip antenna without antenna connector. The maximum gain of this antenna is 3.32dBi.

5. PHOTOGRAPHS OF THE TEST CONFIGURATION

Please refer to the attached file (Test Setup Photo).



6. INFORMATION ON THE TESTING LABORATORIES

We, ADT Corp., were founded in 1988 to provide our best service in EMC, Radio, Telecom and Safety consultation. Our laboratories are accredited and approved by the following approval agencies according to ISO/IEC 17025.

USA	FCC, UL, A2LA
Germany	TUV Rheinland
Japan	VCCI
Norway	NEMKO
Canada	INDUSTRY CANADA, CSA
R.O.C.	TAF, BSMI, NCC
Netherlands	Telefication
Singapore	GOST-ASIA(MOU)
Russia	CERTIS(MOU)

Copies of accreditation certificates of our laboratories obtained from approval agencies can be downloaded from our web site: www.adt.com.tw/index.5/phtml.
If you have any comments, please feel free to contact us at the following:

Linko EMC/RF Lab:
Tel: 886-2-26052180
Fax: 886-2-26051924

Hsin Chu EMC/RF Lab:
Tel: 886-3-5935343
Fax: 886-3-5935342

Hwa Ya EMC/RF/Safety Telecom Lab:
Tel: 886-3-3183232
Fax: 886-3-3185050

Web Site: www.adt.com.tw

The address and road map of all our labs can be found in our web site also.

7. APPENDIX A – MODIFICATIONS RECORDERS FOR ENGINEERING CHANGES TO THE EUT BY THE LAB

No any modifications are made to the EUT by the lab during the test.