



MOTOROLA

Exhibit 11: SAR Test Report IHDT6EK1

Date of test: 28 & 29 September, 2004
Date of Report: 30 September, 2004

Laboratory: Motorola Personal Communications Sector Product Safety & Compliance Laboratory
 600 N. US Highway 45
 Room: MW113
 Libertyville, Illinois 60048

Test Responsible: Steven Hauswirth
 Principal Staff Engineer

Accreditation: This laboratory is accredited to ISO/IEC 17025-1999 to perform the following tests:



<p><u>Tests:</u> Electromagnetic Specific Absorption Rate</p> <p>Simulated Tissue Preparation RF Power Measurement</p>	<p><u>Procedures:</u> ANSI/IEEE C95.1-1992, 1999 (SAR) IEEE C95.3-1991 IEEE P1528 (<i>DRAFT</i>) FCC OET Bulletin 65 (<i>including Supplements A, B, C</i>) Australian Communications Authority Radio Communications (Electromagnetic Radiation – Human Exposure) Standard 1999 CENELEC EN 50361 (2001) APP-0247 DOI-0876, 0900, 0902, 0904, 0915</p>
--	---

On the following products or types of products:
 Wireless Communications Devices (Examples): Two Way Radios; Portable Phones (including Cellular, Licensed Non-Broadcast and PCS); Low Frequency Readers; and Pagers

A2LA certificate #1651-01

Statement of Compliance: Motorola declares under its sole responsibility that portable cellular telephone FCC ID IHDT6EK1 to which this declaration relates, is in conformity with the appropriate General Population/Uncontrolled RF exposure standards, recommendations and guidelines (FCC 47 CFR §2.1093). It also declares that the product was tested in accordance with the appropriate measurement standards, guidelines and recommended practices. Any deviations from these standards, guidelines and recommended practices are noted below:

(none)

©Motorola, Inc. 2004

This test report shall not be reproduced except in full, without written approval of the laboratory.

The results and statements contained herein relate only to the items tested. The names of individuals involved may be mentioned only in connection with the statements or results from this report.

Motorola encourages all feedback, both positive and negative, on this test report.

Table of Contents

1. INTRODUCTION..... 3

2. DESCRIPTION OF THE DEVICE UNDER TEST 3

2.1 Antenna description3

2.2 Device description.....3

3. TEST EQUIPMENT USED..... 3

3.1 Dosimetric System3

3.2 Additional Equipment.....4

4. ELECTRICAL PARAMETERS OF THE TISSUE SIMULATING LIQUID 4

5. SYSTEM ACCURACY VERIFICATION..... 5

6. TEST RESULTS 5

6.1 Head Adjacent Test Results.....6

6.2 Body Worn Test Results7

APPENDIX 1: SAR DISTRIBUTION COMPARISON FOR SYSTEM ACCURACY VERIFICATION..... 9

APPENDIX 2: SAR DISTRIBUTION PLOTS FOR PHANTOM HEAD ADJACENT USE 10

APPENDIX 3: SAR DISTRIBUTION PLOTS FOR BODY WORN CONFIGURATION..... 11

APPENDIX 4: PROBE CALIBRATION CERTIFICATE 12

APPENDIX 5: DIPOLE CHARACTERIZATION CERTIFICATE..... 13

APPENDIX 6: MEASUREMENT UNCERTAINTY BUDGET..... 14

APPENDIX 7: PHOTOGRAPHS OF DEVICE UNDER TEST 18

1 Introduction

The Motorola Personal Communications Sector Product Safety Laboratory has performed measurements of the maximum potential exposure to the user of portable cellular phone (FCC ID IHDT6EK1). The Specific Absorption Rate (SAR) of this product was measured. The portable cellular phone was tested in accordance with FCC OET Bulletin 65 Supplement C 01-01.

2 Description of the Device Under Test

2.1 Antenna description

Type	Internal	
Location	Upper Portion of Rear of Phone	
Dimensions	Length	45mm
	Width	10mm
Configuration	Helix	

2.2 Device description

FCC ID Number	IHDT6EK1							
Serial number	FU0ZP22225							
Mode(s) of Operation	GSM 900	GSM 1800	GSM 1900	GPRS 900	GPRS 1800	GPRS 1900	UMTS	BlueTooth
Modulation Mode(s)	GSM	GSM	GSM	GSM	GSM	GSM	WCDMA	BlueTooth
Maximum Output Power Setting	33.00 dBm	30.00 dBm	30.00 dBm	33.00 dBm	30.00 dBm	30.00 dBm	22.00 dBm	4.00 dBm
Duty Cycle	1:8	1:8	1:8	2:8	2:8	2:8	1:1	1:1
Transmitting Frequency Rang(s)	880.2-914.8MHz	1710.2-1784.8MHz	1850.20 – 1909.80MHz	880.2-914.8MHz	1710.2-1784.8MHz	1850.20 – 1909.80MHz	1920.3-1979.7MHz	2400 - 2483.5MHz
Production Unit or Identical Prototype (47 CFR §2.908)	Identical Prototype							
Device Category	Portable							
RF Exposure Limits	General Population / Uncontrolled							

3 Test Equipment Used

3.1 Dosimetric System

The Motorola Personal Communications Sector Product Safety & Compliance Laboratory utilizes a Dosimetric Assessment System (Dasy3™ v3.1d) manufactured by Schmid & Partner Engineering AG (SPEAG™), of Zurich Switzerland. All the SAR measurements are taken within a shielded enclosure. The overall RSS uncertainty of the measurement system is ±11.7% (K=1) with an expanded uncertainty of ±23.0% (K=2). The measurement

uncertainty budget is given in Appendix 6. Per IEEE 1528, this uncertainty budget is applicable to the SAR range of 0.4 W/kg to 10 W/kg. The list of calibrated equipment used for the measurements is shown below.

Description	Serial Number	Cal Due Date
DASY3 DAE V1	SN376	22-Dec-04
E-Field Probe ET3DV6	SN1391	24-Nov-04
Dipole Validation Kit, D1800V2	SN273TR	2-Apr-05
S.A.M. Phantom used for 1900MHz	TP-1235	

3.2 Additional Equipment

Description	Serial Number	Cal Due Date
Signal Generator HP8648C	3847A04822	6-Feb-05
Power Meter E4419B	GB39511087	5-Apr-05
Power Sensor #1 - E9301A	US39211009	5-Aug-05
Power Sensor #2 - E9301A	US39210915	5-Aug-05
Network Analyzer HP8753ES	US39171846	29-Oct-04
Dielectric Probe Kit HP85070B	US99360074	N/A

4 Electrical parameters of the tissue simulating liquid

Prior to conducting SAR measurements, the relative permittivity, ϵ_r , and the conductivity, σ , of the tissue simulating liquids were measured with the HP85070 Dielectric Probe Kit. These values, along with the temperature of the tissue simulate are shown in the table below. The recommended limits for maximum permittivity and minimum conductivity are also shown. These come from the Federal Communication Commission, OET Bulletin 65 Supplement C 01-01. It is seen that the measured parameters are satisfactory for compliance testing.

f (MHz)	Tissue type	Limits / Measured	Dielectric Parameters		
			ϵ_r	σ (S/m)	Temp (°C)
1880	Head	Measured, 28-Sep-04	38.8	1.47	19.2
		Recommended Limits	40.0 ±5%	1.40 ±5%	18-25
	Body	Measured, 29-Sep-04	51.5	1.58	19.2
		Recommended Limits	53.3 ±5%	1.52 ±5%	18-25

The list of ingredients and the percent composition used for the tissue simulates are indicated in the table below.

Ingredient	800MHz	800MHz	1900MHz	1900MHz
	Head	Body	Head	Body
Sugar	57.0	44.9	--	30.80
DGBE	--	--	47.0	--
Water	40.45	53.06	52.8	68.91
Salt	1.45	0.94	0.2	0.29
HEC	1.0	1.0	--	--
Bact.	0.1	0.1	--	--

5 System Accuracy Verification

A system accuracy verification of the DASY3 was performed using the measurement equipment listed in Section 3.1. The daily system accuracy verification occurs within center section of the SAM phantom.

A SAR measurement was performed to see if the measured SAR was within +/- 10% from the target SAR indicated on the dipole certification sheet. These tests were done at 900MHz and/or 1800MHz. These frequencies are within 100MHz of the mid-band frequency of the test device. This is within the allowable window given in Supplement C 01-01 *Appendix D System Verification* section item #5. The test was conducted on the same days as the measurement of the DUT. Recommended limits for maximum permittivity, minimum conductivity are shown in the table below. These come from the Federal Communication Commission, OET Bulletin 65 Supplement C 01-01. The obtained results from the system accuracy verification are displayed in the table below. The distributions of SAR compare well with those of the reference measurements (see Appendix 1). The tissue stimulant depth was verified to be 15.0cm ±0.5cm. Z-axis scans showing the SAR penetration are also included in Appendix 1. SAR values are normalized to 1W forward power delivered to the dipole.

The following probe conversion factors were used on the E-Field probe(s) used for the system accuracy verification measurements:

Description	Serial Number	f (MHz)	Conversion Factor	Cal Cert pg #
E-Field Probe ET3DV6	SN1391	900	N/A	
		1800	5.3	7 of 10

f (MHz)	Description	SAR (W/kg), 1gram	Dielectric Parameters		Ambient Temp (°C)	Tissue Temp (°C)
			ϵ_r	σ (S/m)		
1800	Measured, 28-Sep-04	40.8	38.9	1.38	20	19.1
	Recommended Limits	40.7	40.0 ±5%	1.4 ±5%	18-25	18-25

6 Test Results

The test sample was operated in a test mode that allows control of the transmitter without the need to place actual phone calls. For the purposes of this test the unit is commanded to test mode and manually set to the proper channel, transmitter power level and transmit mode of operation. The phone was tested in the configurations stipulated in OET Bulletin 65 Supplement C 01-01. Motorola also followed the requirements in Supplement. C / Appendix D: SAR Measurement Procedures, section titled “*Devices Operating Next To A Person’s Ear* “. These directions state “The device should be tested on the left and right side of the head phantom in the “Cheek/Touch” and “Ear/Tilt” positions. When applicable, each configuration should be tested with the antenna in its fully extended and fully retracted positions. These test configurations should be tested at the high, middle and low frequency channels of each operating mode; for example, AMPS, CDMA, and TDMA. If the SAR measured at the middle channel for each test configuration (left, right, Cheek/Touch, Tile/Ear, extended and retracted) is at least 2.0 dB lower than the SAR limit, testing at the high and low channels is optional for such test configuration(s).”

The DASY v3.1d SAR measurement system specified in section 3.1 was utilized within the intended operations as set by the SPEAG™ setup. The phone was positioned into the measurement configurations using the positioner supplied with the DASY 3.1d SAR measurement system. The measured dielectric constant of the material used for the positioner is less than 2.9 and the loss tangent is less than 0.02 (± 30%) at 850MHz. The default settings for the “coarse” and “cube” scans were chosen and use for measurements. The grid spacing of the course scan was set to 15cm as shown in the SAR plots included in appendix 2 and 3. Please refer to the DASY manual for additional information on SAR scanning procedures and algorithms used.

The Cellular Phone (FCC ID IHDT6EK1) has the SNN5697A as the only available battery option. This battery was used to do all of the SAR testing. The phone was placed in the SAR measurement system with a fully charged battery.

6.1 Head Adjacent Test Results

To aid in positioning repeatability, the ear reference line of the device and the axis reference line of the device have been physically added using a non-metallic marker.

- Per Figure 1, the "Ear Reference Line" is centered vertically through the center of the listening area (as defined by the speaker holes in the housing).
- The "Axis Reference Line" bisects the front surface of the device at its top and bottom edges.
- The intersection of these two lines defines the location of the "Ear Reference Point".

The lines drawn on the device extended to the outside edges, as shown in blue in the figure below, & wrap around the sides of the device.

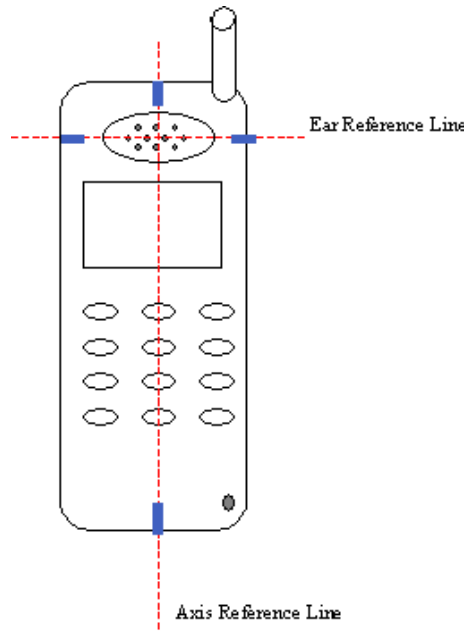

The SAR results shown in tables 1 and 2 are maximum SAR values averaged over 1 gram of phantom tissue. Also shown are the measured conducted output powers, the temperature of the test facility during the test, the temperature of the tissue simulate after the test, the measured drift and the extrapolated SAR. The exact method of extrapolation is $\text{New SAR} = \text{Old SAR} * 10^{(-\text{drift}/10)}$. The SAR reported at the end of the measurement process by the DASY™ measurement system can be scaled up by the measured drift to determine the SAR at the beginning of the measurement process. This is the most conservative SAR because it corresponds to the average output power at the beginning of the SAR test. This extrapolation has been done because when the DUT is operating properly it may exhibit a slump in radiated power and SAR over time. This is verified by measuring the SAR drift after the test. The test conditions indicated as bold numbers in the following table are included in Appendix 2

The SAR measurements were performed using the SAM phantoms listed in section 3.1. Since same phantoms and tissue simulate are used for the system accuracy verification as the device SAR measurements, the Z-axis scans included in within Appendix 1 are applicable for verification of tissue simulate depth to be 15.0cm ±0.5cm. All other test conditions measured lower SAR values than those included in Appendix 2.

The following probe conversion factors were used on the E-Field probe(s) used for the head adjacent measurements:

Description	Serial Number	f (MHz)	Conversion Factor	Cal Cert pg #
E-Field Probe ET3DV6	SN1391	835		
		1900	5.3	7 of 10

f (MHz)	Description	Conducted Output Power (dBm)	Cheek / Touch Position								
			Left Head				Right Head				
			Measured (W/kg)	Drift (dB)	Extrapolated (W/kg)	Simulate Temp (°C)	Measured (W/kg)	Drift (dB)	Extrapolated (W/kg)	Simulate Temp (°C)	
Digital 1900MHz	Channel 512	30.02									
	Channel 661	29.99	0.425	0.01	0.43	19.2	0.597	-0.13	0.62	19.2	
	Channel 810	29.92									

Table 1: SAR measurement results for the portable cellular telephone FCC ID IHDT6EK1 at highest possible output power. Measured against the left head in the Cheek/Touch Position.

f (MHz)	Description	Conducted Output Power (dBm)	15° Tilt Position								
			Left Head				Right Head				
			Measured (W/kg)	Drift (dB)	Extrapolated (W/kg)	Simulate Temp (°C)	Measured (W/kg)	Drift (dB)	Extrapolated (W/kg)	Simulate Temp (°C)	
Digital 1900MHz	Channel 512	30.02									
	Channel 661	29.99	0.604	0.06	0.60	19.2	0.729	-0.02	0.73	19.2	
	Channel 810	29.92									

Table 2: SAR measurement results for the portable cellular telephone FCC ID IHDT6EK1 at highest possible output power. Measured against the right head in the 15° Tilt Position.

6.2 Body Worn Test Results

The SAR results shown in table 3 are the maximum SAR values averaged over 1 gram of phantom tissue. Also shown are the measured conducted output powers, the temperature of the test facility during the test, the temperature of the tissue simulate after the test, the measured drift and the extrapolated SAR. The exact method of extrapolation is $New\ SAR = Old\ SAR * 10^{(-drift/10)}$. The SAR reported at the end of the measurement process by the DASY™ measurement system can be scaled up by the measured drift to determine the SAR at the beginning of the measurement process. This is the most conservative SAR because it corresponds to the average output power at the beginning of the SAR test. This extrapolation has been done because when the DUT is operating properly it may exhibit a slump in radiated power and SAR over time. This is verified by measuring the SAR drift after the test. The test conditions indicated as bold numbers in the following table are included in Appendix 3. All other test conditions measured lower SAR values than those included in Appendix 3.

A “flat” phantom was for the body-worn tests. This “flat” phantom is made out of 1” thick natural High Density Polyethylene with a thickness at the bottom equal to 2.0mm. It measures 52.7cm(long) x 26.7cm(wide) x 21.2cm(tall). The measured dielectric constant of the material used is less than 2.3 and the loss tangent is less than 0.0046 all the way up to 2.184GHz.

The tissue stimulant depth was verified to be 15.0cm ±0.5cm. The same device holder described in section 6 was used for positioning the phone. The functional accessories were divided into two categories, the ones with metal components and the ones with non-metal components. For non-metallic component accessories', testing was performed on the accessory that displayed the closest proximity to the flat phantom. Each metallic component accessory, if any, was checked for uniqueness of metal component so that each is tested with the device. If multiple accessories shared an identical metal component, only the accessory that dictates the closest spacing to the body was tested. The cellular phone was tested with a headset connected to the device for all body-worn SAR measurements.

The following probe conversion factors were used on the E-Field probe(s) used for the body worn measurements:

Description	Serial Number	f (MHz)	Conversion Factor	Cal Cert pg #
E-Field Probe ET3DV6	SN1391	835		
		1900	4.9	8 of 10

Testing was performed only in the configuration that resulted in the highest SAR value from the original filing.

f (MHz)	Description	Conducted Output Power (dBm)	Body Worn with SYN1113A			
			Voice Call with Bluetooth			
			Measured (W/kg)	Drift (dB)	Extrapolated (W/kg)	Simulate Temp (°C)
Digital 1900MHz	Channel 512	30.02				
	Channel 661	29.99	0.535	-0.12	0.55	19.2
	Channel 810	29.92				

Table 3: SAR measurement results for the portable cellular telephone FCC ID IHDT6EK1 at highest possible output power. Measured against the body.

Appendix 1

SAR distribution comparison for the system accuracy verification

Dipole 1800 MHz

1800 MHz System Performance Check / Dipole Sn# 273tr

PM2 Power = 202mW Refl.Pwr PM3= -23.98dB

Sim.Temp@SPC = 19.1°C Room Temp @ SPC = 20°C

R2 Amy Twin Phantom Rev.3 ; section 1

Probe: ET3DV6 - SN1391 - Validation.4; ConvF(5.30,5.30,5.30); Crest factor: 1.0; 1800 MHz VALIDATION: $\sigma = 1.38$ mho/m $\epsilon_r = 38.9$ $\rho = 1.00$ g/cm³

Cubes (2): Peak: 15.2 mW/g ± 0.02 dB, SAR (1g): 8.24 mW/g ± 0.03 dB, SAR (10g): 4.34 mW/g ± 0.06 dB, (Worst-case extrapolation)

Penetration depth: 8.4 (8.0, 9.2) [mm]

Powerdrift: 0.02 dB

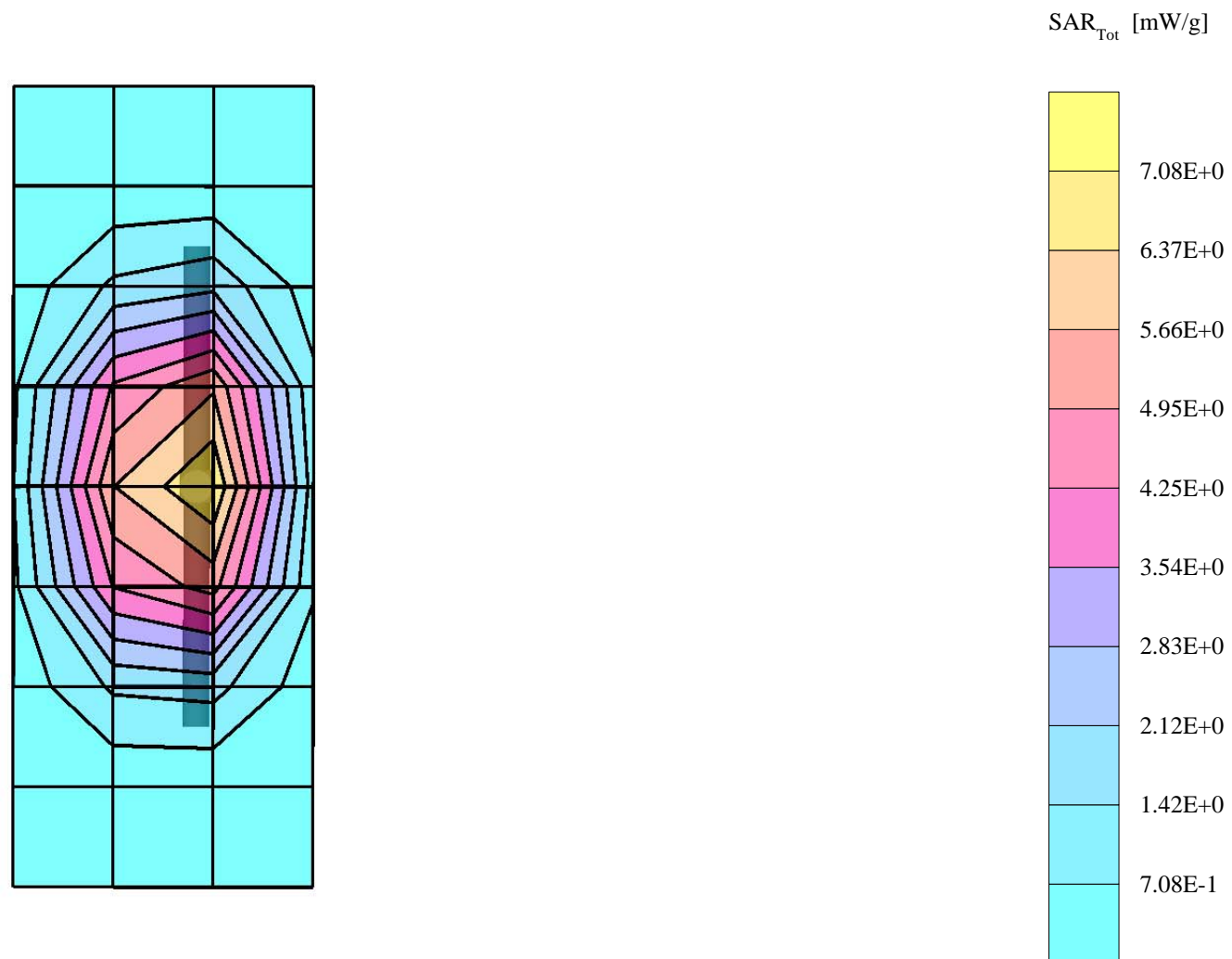

Dipole 1800 MHz

1800 MHz System Performance Check / Dipole Sn# 273tr

PM2 Power = 202mW Refl.Pwr PM3= -23.98dB

Sim.Temp@SPC = 19.1°C Room Temp @ SPC = 20°C

R2 Amy Twin Phantom Rev.3 Phantom; Section; Position: ; Frequency: 1800 MHz

Probe: ET3DV6 - SN1391 - Validation.4; ConvF(5.30,5.30,5.30); Crest factor: 1.0; 1800 MHz VALIDATION: $\sigma = 1.38$ mho/m $\epsilon_r = 38.9$ $\rho = 1.00$ g/cm³

: , ()

Z-Axis: Dx = 0.0, Dy = 0.0, Dz = 5.0

Penetration depth: 8.1 (7.8, 9.0) [mm]

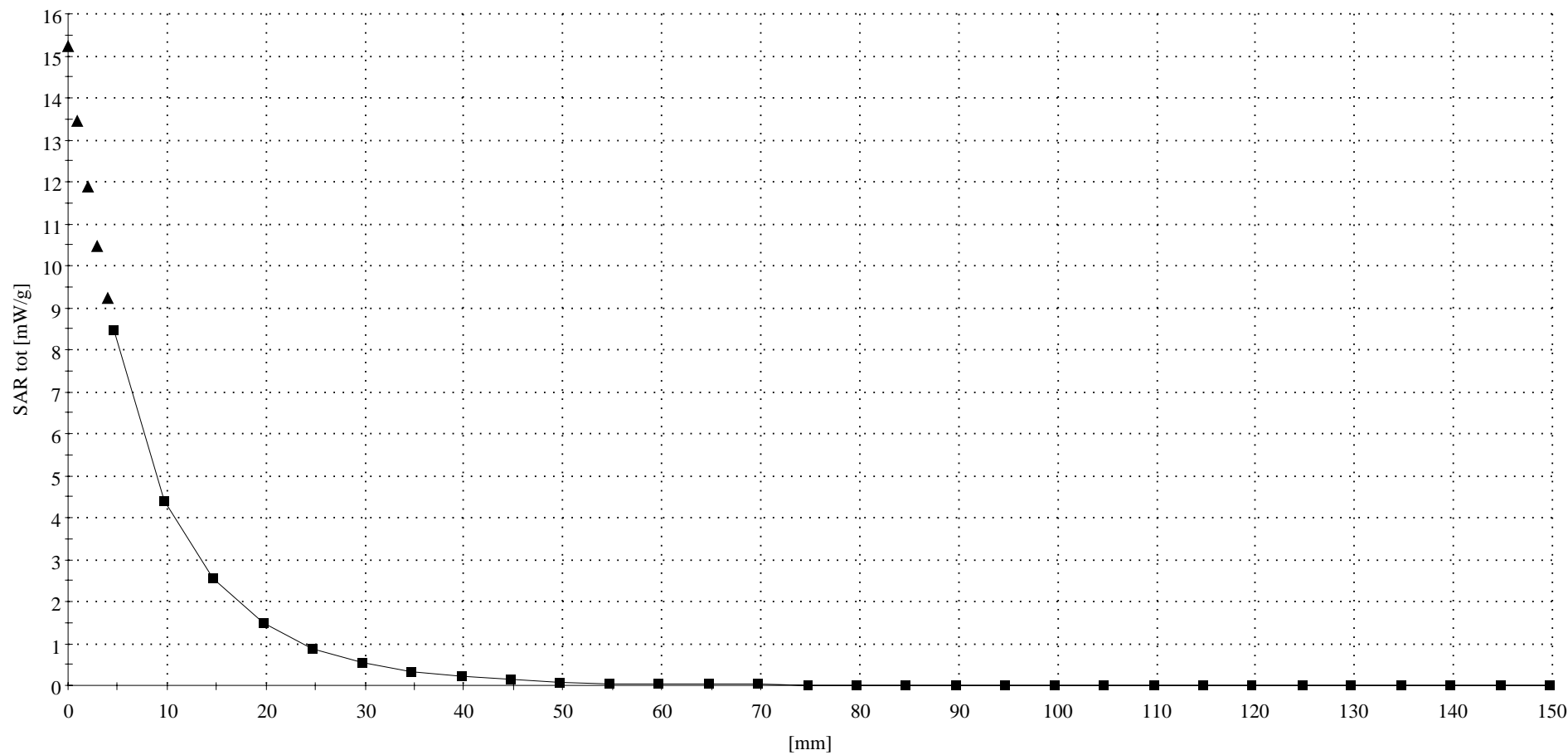

Appendix 2

SAR distribution plots for Phantom Head Adjacent Use

s/n: FU0ZP22225

Ch# 661 / Pwr Step: 0

Type of Modulation: GSM1900

DEVICE POSITION (cheek or rotated): Cheek

R# 2 TP-1235 GLYCOL SAM Expanded (Rev. 2)-9Jan03; Left Hand

Probe: ET3DV6 - SN1391 - IEEE Head.2; ConvF(5.30,5.30,5.30); Crest factor: 8.0; 1880 MHz Head & Body: $\sigma = 1.47$ mho/m $\epsilon_r = 38.8$ $\rho = 1.00$ g/cm³

Cube 7x7x7: Peak: 0.749 mW/g, SAR (1g): 0.425 mW/g, SAR (10g): 0.239 mW/g, (Worst-case extrapolation)

Penetration depth: 9.1 (8.9, 9.7) [mm]

Powerdrift: 0.01 dB

Antenna Position: Internal

Battery Model #: SNN5697A

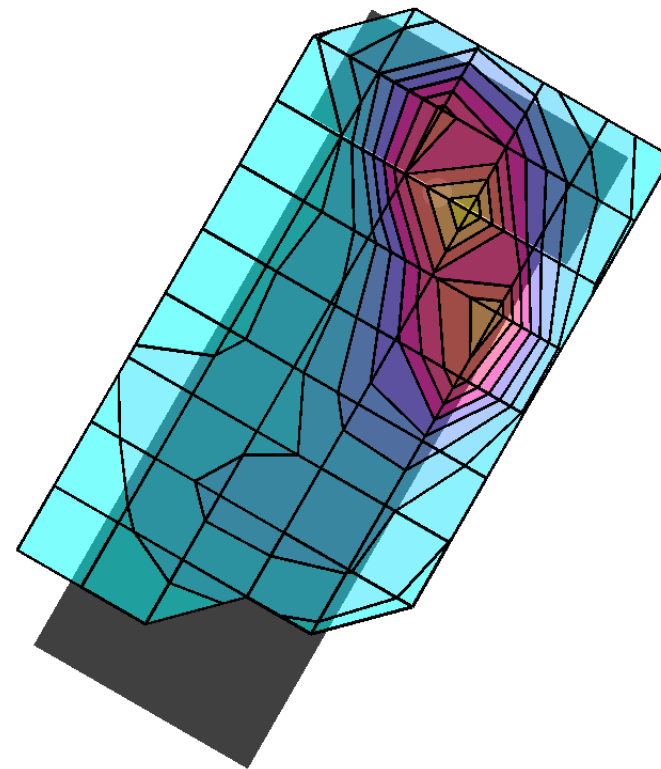
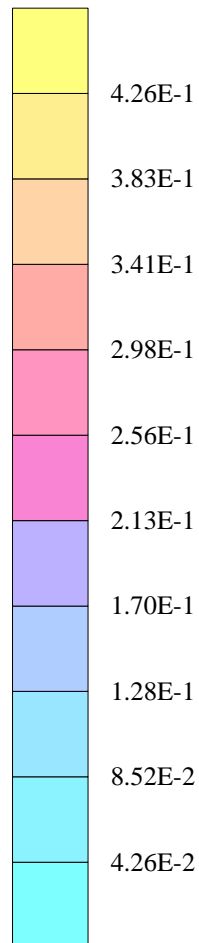
SAR_{Tot} [mW/g]

s/n: FU0ZP22225

Ch# 661 / Pwr Step: 0

Type of Modulation: GSM

DEVICE POSITION (cheek or rotated): Rotated

R# 2 TP-1235 GLYCOL SAM Expanded (Rev. 2)-9Jan03; Left Hand

Probe: ET3DV6 - SN1391 - IEEE Head.2; ConvF(5.30,5.30,5.30); Crest factor: 8.0; 1880 MHz Head & Body: $\sigma = 1.47$ mho/m $\epsilon_r = 38.8$ $\rho = 1.00$ g/cm³

Cube 7x7x7: Peak: 1.07 mW/g, SAR (1g): 0.604 mW/g, SAR (10g): 0.328 mW/g, (Worst-case extrapolation)

Penetration depth: 9.0 (8.7, 9.6) [mm]

Powerdrift: 0.06 dB

Antenna Position: Internal

Battery Model #: SNN5697A

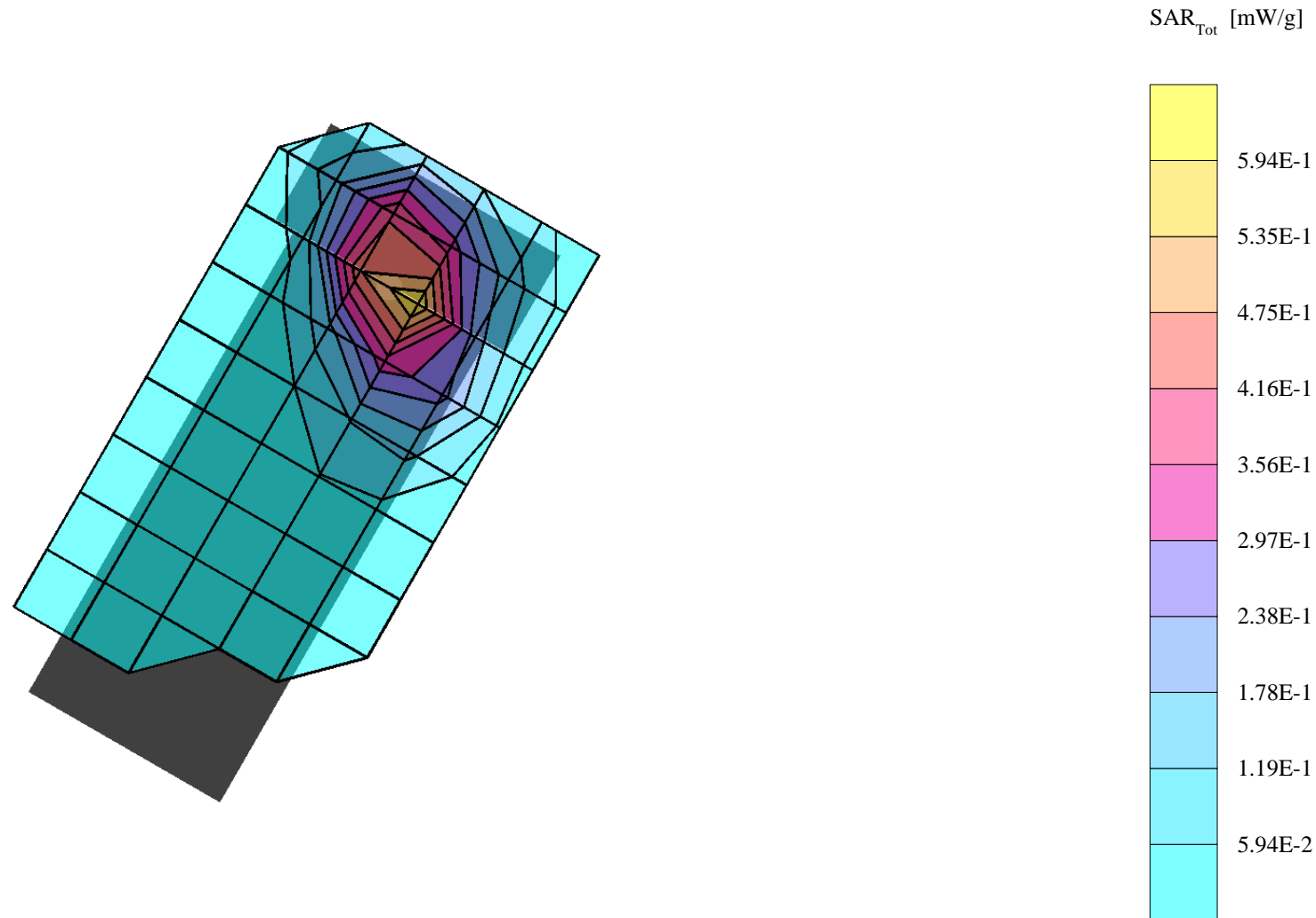

s/n: FU0ZP22225

Ch# 661 / Pwr Step: 0

Type of Modulation: GSM1900

DEVICE POSITION (cheek or rotated): Cheek

R# 2 TP-1235 GLYCOL SAM Expanded (Rev. 2)-9Jan03; Right Hand

Probe: ET3DV6 - SN1391 - IEEE Head.2; ConvF(5.30,5.30,5.30); Crest factor: 8.0; 1880 MHz Head & Body: $\sigma = 1.47$ mho/m $\epsilon_r = 38.8$ $\rho = 1.00$ g/cm³

Cube 7x7x7: Peak: 1.16 mW/g, SAR (1g): 0.597 mW/g, SAR (10g): 0.298 mW/g, (Worst-case extrapolation)

Penetration depth: 7.7 (7.4, 8.5) [mm]

Powerdrift: -0.13 dB

Antenna Position: Internal

Battery Model #: SNN5697A

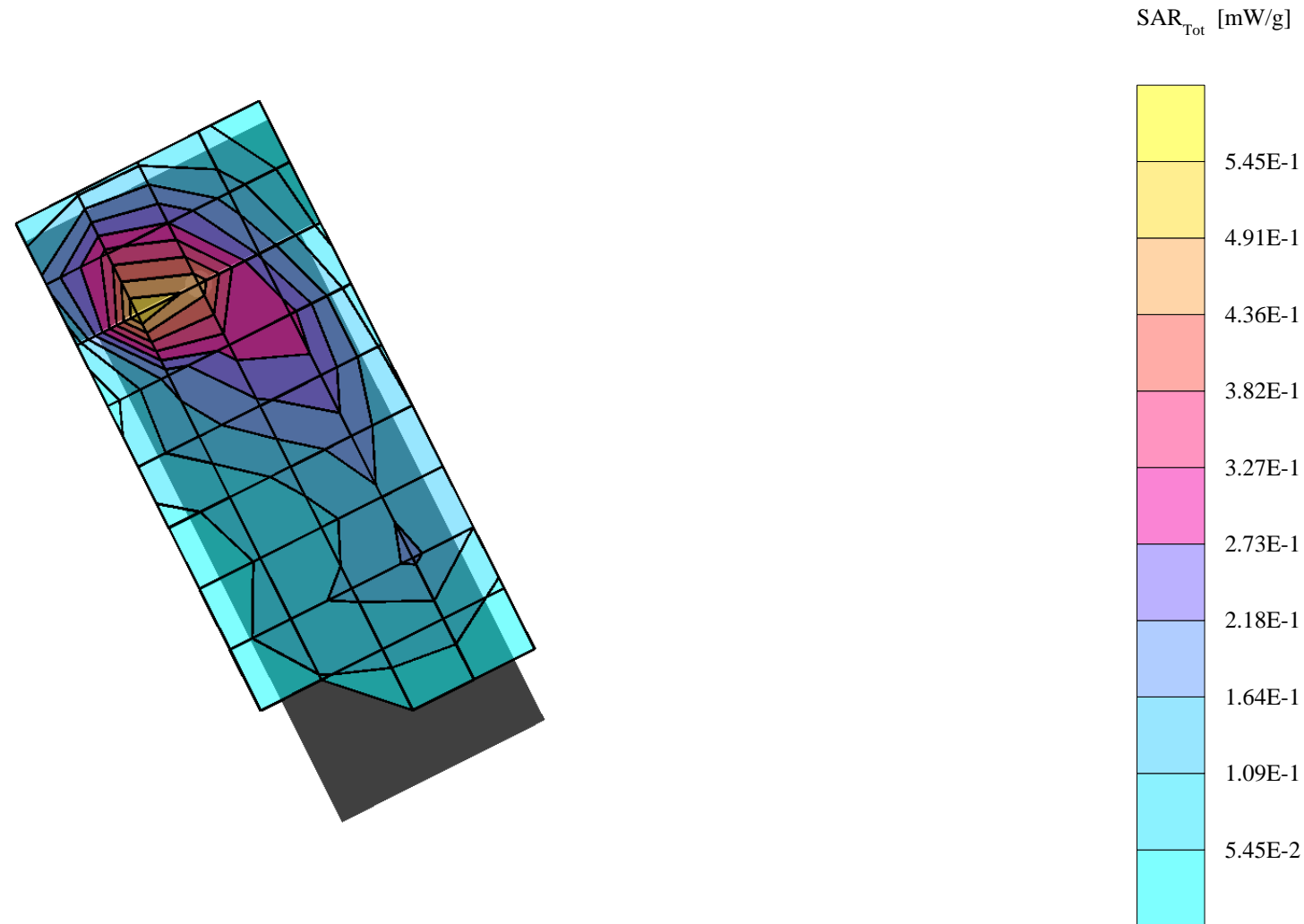

s/n: FU0ZP22225

Ch# 661 / Pwr Step: 0

Type of Modulation: GSM1900

DEVICE POSITION (cheek or rotated): Rotated

R# 2 TP-1235 GLYCOL SAM Expanded (Rev. 2)-9Jan03; Right Hand

Probe: ET3DV6 - SN1391 - IEEE Head.2; ConvF(5.30,5.30,5.30); Crest factor: 8.0; 1880 MHz Head & Body: $\sigma = 1.47$ mho/m $\epsilon_r = 38.8$ $\rho = 1.00$ g/cm³

Cube 7x7x7: Peak: 1.39 mW/g, SAR (1g): 0.729 mW/g, SAR (10g): 0.364 mW/g, (Worst-case extrapolation)

Penetration depth: 8.3 (7.9, 9.0) [mm]

Powerdrift: -0.02 dB

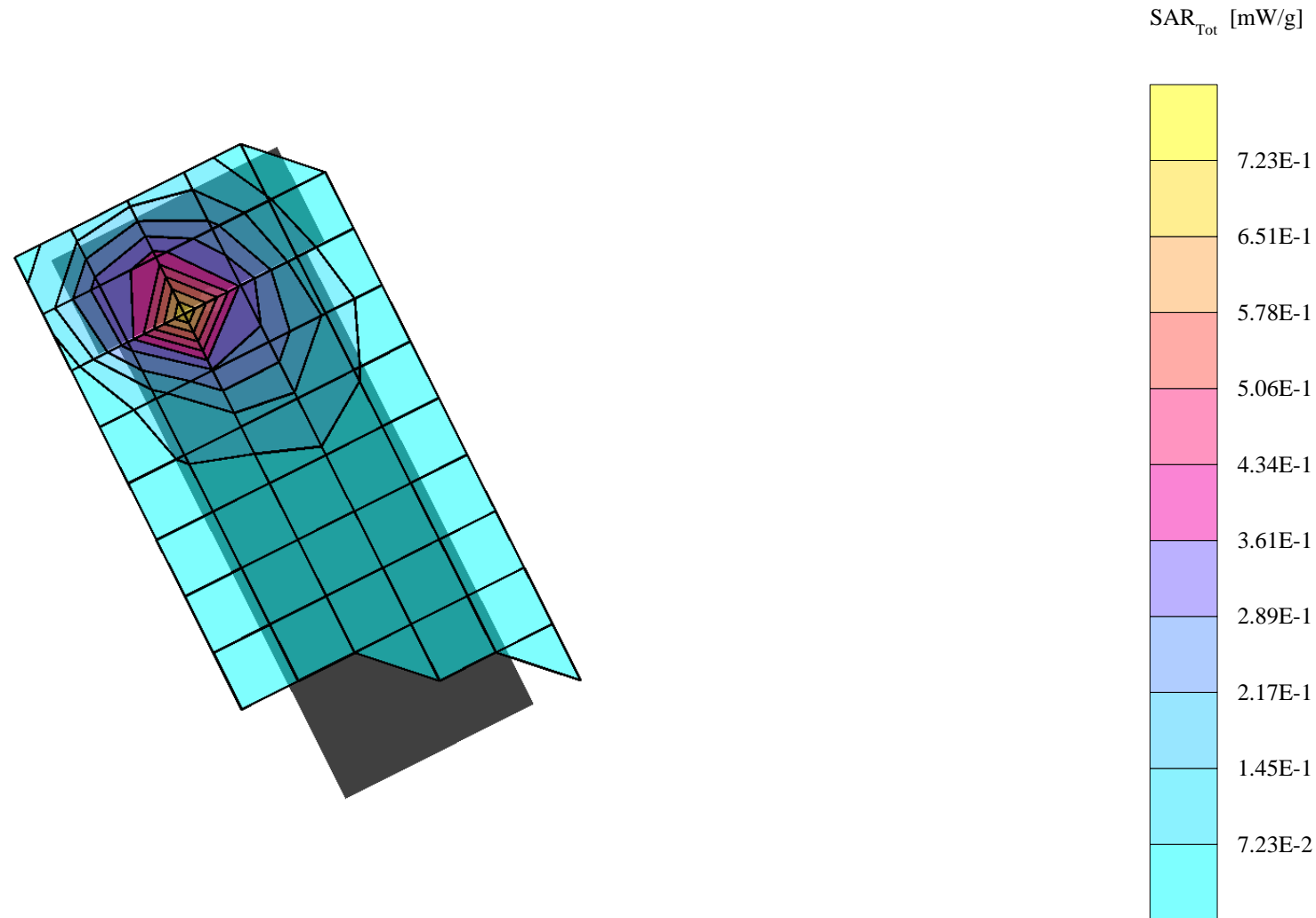
Antenna Position: Internal
Battery Model #: SNN5697A

Appendix 3

SAR distribution plots for Body Worn Configuration

s/n: FU0ZP22225

Ch# 661 / Pwr Step: 0

Antenna Position: INTERNAL

Type of Modulation: GSM

Battery Model #: SNN5697A

Accessory Model #: POUCH SYN1113A / BLUETOOTH

R2 Amy Twin Phantom Rev.3 ; section 1

Probe: ET3DV6 - SN1391 - FCC Body.2; ConvF(4.90,4.90,4.90); Crest factor: 8.0; 1880 MHz Head & Body: $\sigma = 1.58$ mho/m $\epsilon_r = 51.5$ $\rho = 1.00$ g/cm³

Cube 7x7x7: Peak: 0.692 mW/g, SAR (1g): 0.395 mW/g, SAR (10g): 0.223 mW/g, (Worst-case extrapolation)

Powerdrift: -0.03 dB

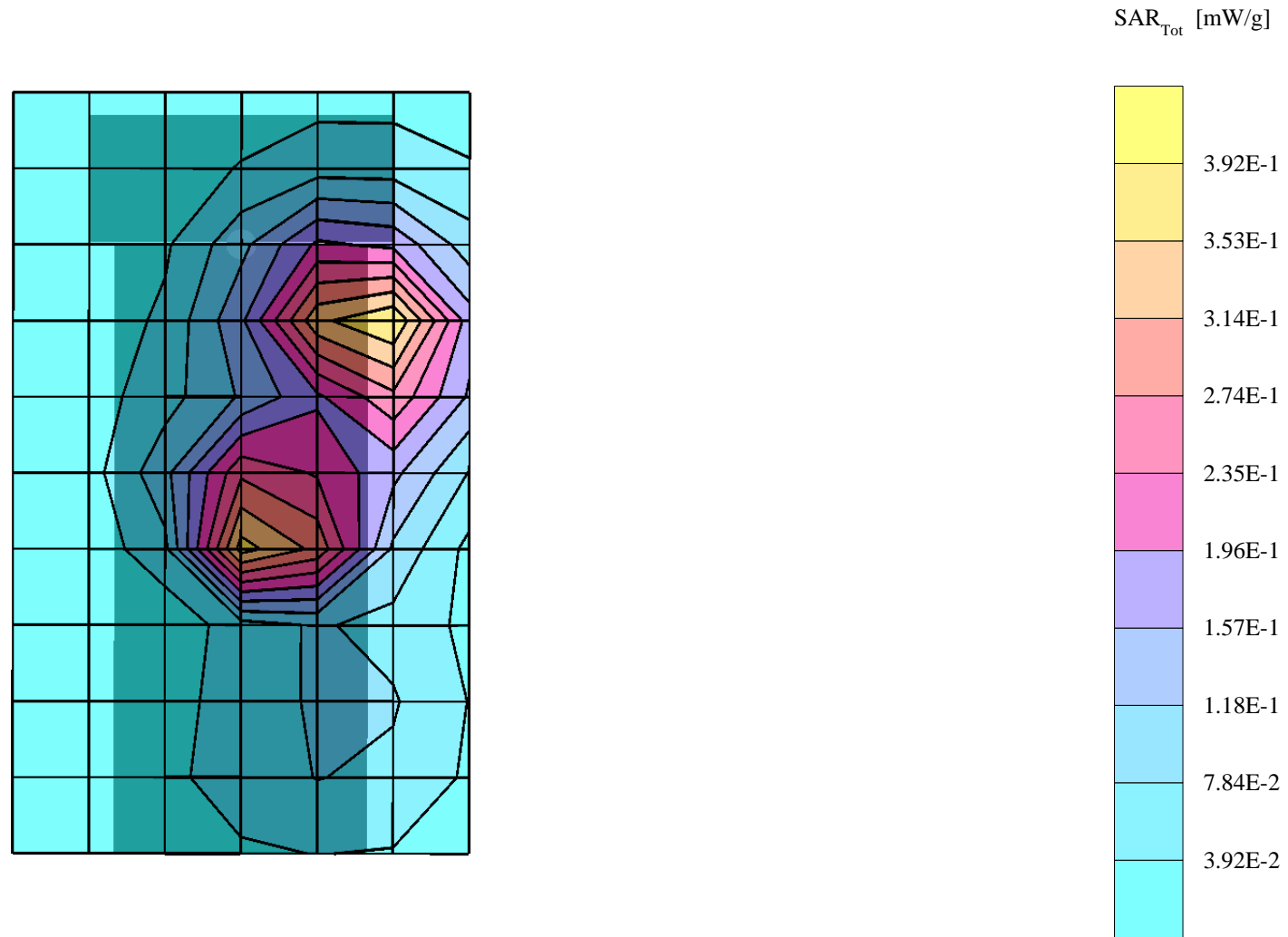

Appendix 4
Probe Calibration Certificate

Client **Motorola (MRO)**

CALIBRATION CERTIFICATE

Object(s) **ET3DV6 - SN: 1391**

Calibration procedure(s) **QA CAL-01 v2
Calibration procedure for dosimetric E-field probes**

Calibration date: **November 24, 2003**

Condition of the calibrated item **In Tolerance (according to the specific calibration document)**

This calibration statement documents traceability of M&TE used in the calibration procedures and conformity of the procedures with the ISO/IEC 17025 international standard.

All calibrations have been conducted in the closed laboratory facility: environment temperature 22 +/- 2 degrees Celsius and humidity < 75%.

Calibration Equipment used (M&TE critical for calibration)

Model Type	ID #	Cal Date (Calibrated by, Certificate No.)	Scheduled Calibration
Power meter EPM E4419B	GB41293874	2-Apr-03 (METAS, No 252-0250)	Apr-04
Power sensor E4412A	MY41495277	2-Apr-03 (METAS, No 252-0250)	Apr-04
Reference 20 dB Attenuator	SN: 5086 (20b)	3-Apr-03 (METAS No. 251-0340)	Apr-04
Fluke Process Calibrator Type 702	SN: 6295803	8-Sep-03 (Sintrel SCS No. E-030020)	Sep-04
Power sensor HP 8481A	MY41092180	18-Sep-02 (SPEAG, in house check Oct-03)	In house check: Oct 05
RF generator HP 8684C	US3642U01700	4-Aug-99 (SPEAG, in house check Aug-02)	In house check: Aug-05
Network Analyzer HP 8753E	US37390585	18-Oct-01 (SPEAG, in house check Oct-03)	In house check: Oct 05

Calibrated by: **Name: Nico Vetterli, Function: Technician, Signature: [Handwritten Signature]**

Approved by: **Name: Katja Pokovic, Function: Laboratory Director, Signature: [Handwritten Signature]**

Date issued: November 25, 2003

This calibration certificate is issued as an intermediate solution until the accreditation process (based on ISO/IEC 17025 International Standard) for Calibration Laboratory of Schmid & Partner Engineering AG is completed.

Probe ET3DV6

SN:1391

Manufactured:	October 1, 1999
Last calibration:	November 20, 2002
Recalibrated:	November 24, 2003

Calibrated for DASY Systems

(Note: non-compatible with DASY2 system!)

DASY - Parameters of Probe: ET3DV6 SN:1391

Sensitivity in Free Space

NormX	1.86 $\mu\text{V}/(\text{V}/\text{m})^2$
NormY	1.72 $\mu\text{V}/(\text{V}/\text{m})^2$
NormZ	1.73 $\mu\text{V}/(\text{V}/\text{m})^2$

Diode Compression

DCP X	92	mV
DCP Y	92	mV
DCP Z	92	mV

Sensitivity in Tissue Simulating Liquid

Head **900 MHz** $\epsilon_r = 41.5 \pm 5\%$ $\sigma = 0.97 \pm 5\%$ mho/m

Valid for f=800-1000 MHz with Head Tissue Simulating Liquid according to EN 50361, P1528-200X

ConvF X	6.5 $\pm 9.5\%$ (k=2)	Boundary effect:
ConvF Y	6.5 $\pm 9.5\%$ (k=2)	Alpha 0.53
ConvF Z	6.5 $\pm 9.5\%$ (k=2)	Depth 2.20

Head **1800 MHz** $\epsilon_r = 40.0 \pm 5\%$ $\sigma = 1.40 \pm 5\%$ mho/m

Valid for f=1710-1910 MHz with Head Tissue Simulating Liquid according to EN 50361, P1528-200X

ConvF X	5.3 $\pm 9.5\%$ (k=2)	Boundary effect:
ConvF Y	5.3 $\pm 9.5\%$ (k=2)	Alpha 0.58
ConvF Z	5.3 $\pm 9.5\%$ (k=2)	Depth 2.43

Boundary Effect

Head **900 MHz** Typical SAR gradient: 5 % per mm

Probe Tip to Boundary	1 mm	2 mm
SAR _{be} [%] Without Correction Algorithm	11.1	6.1
SAR _{be} [%] With Correction Algorithm	0.3	0.5

Head **1800 MHz** Typical SAR gradient: 10 % per mm

Probe Tip to Boundary	1 mm	2 mm
SAR _{be} [%] Without Correction Algorithm	14.4	9.2
SAR _{be} [%] With Correction Algorithm	0.1	0.0

Sensor Offset

Probe Tip to Sensor Center	2.7	mm
Optical Surface Detection	1.1 \pm 0.2	mm

Receiving Pattern (ϕ , $\theta = 0^\circ$)

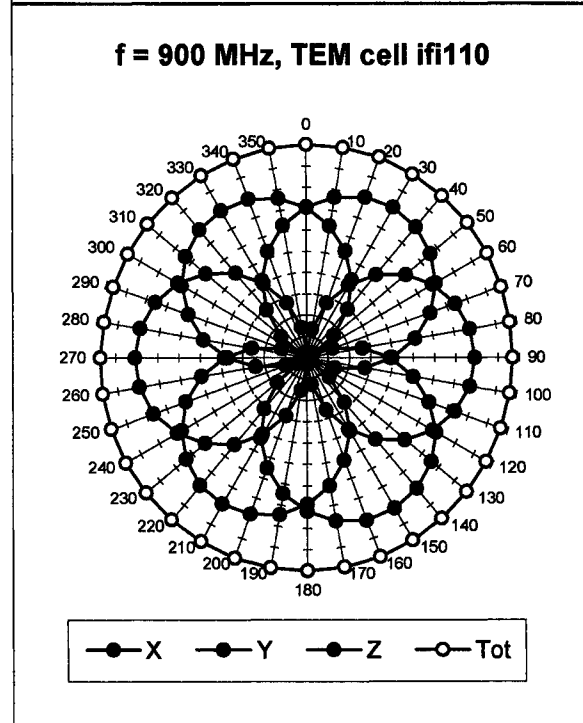
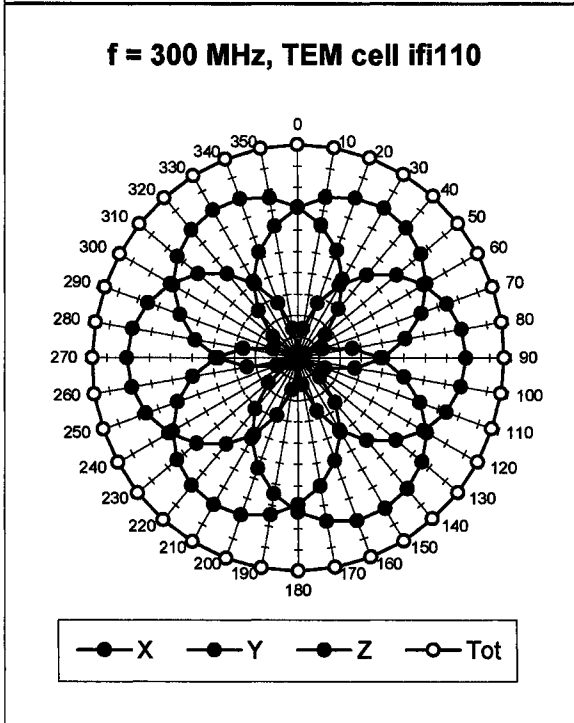
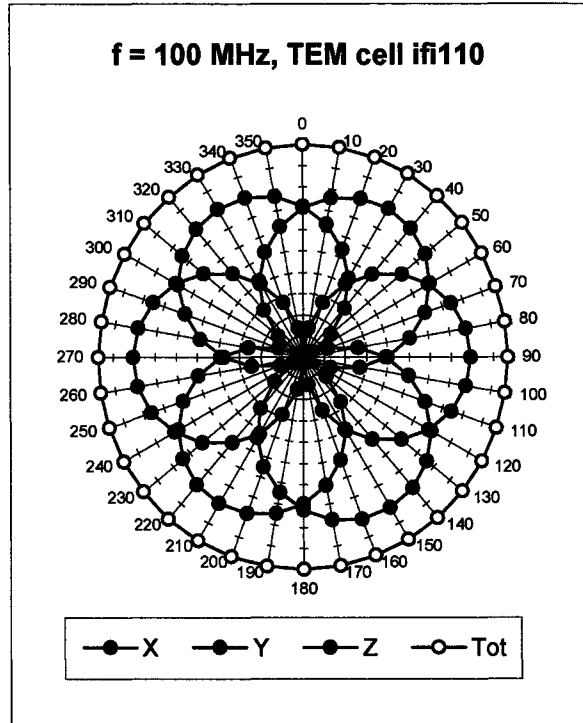
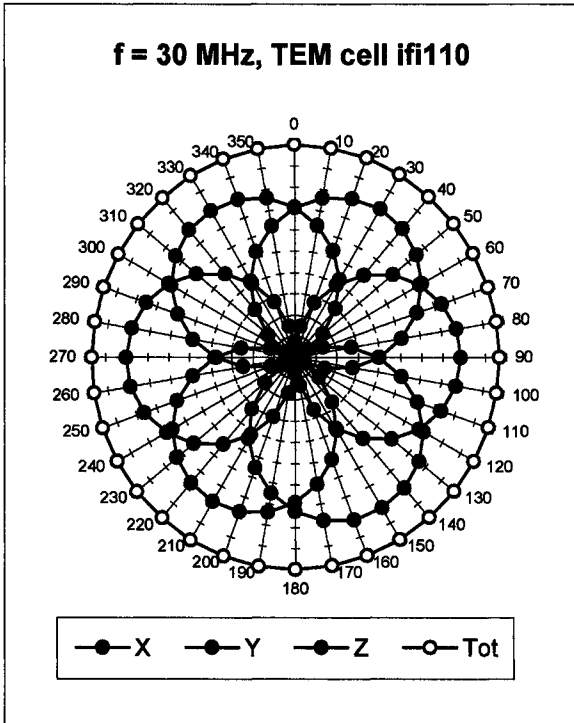

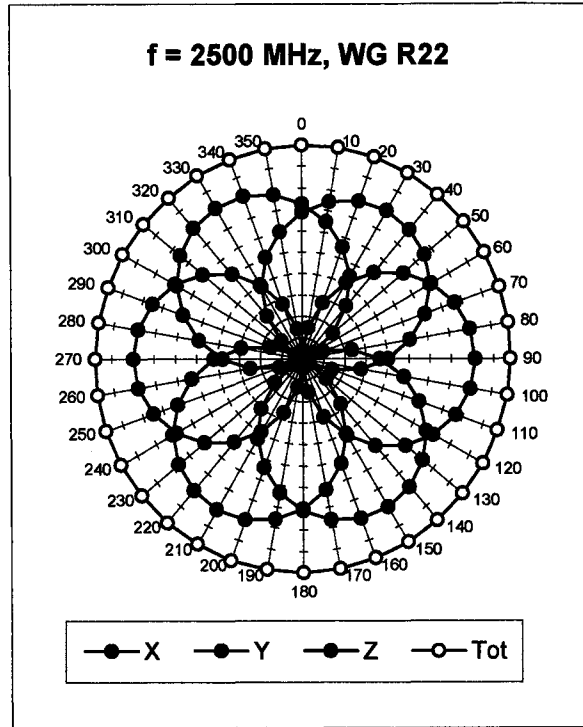
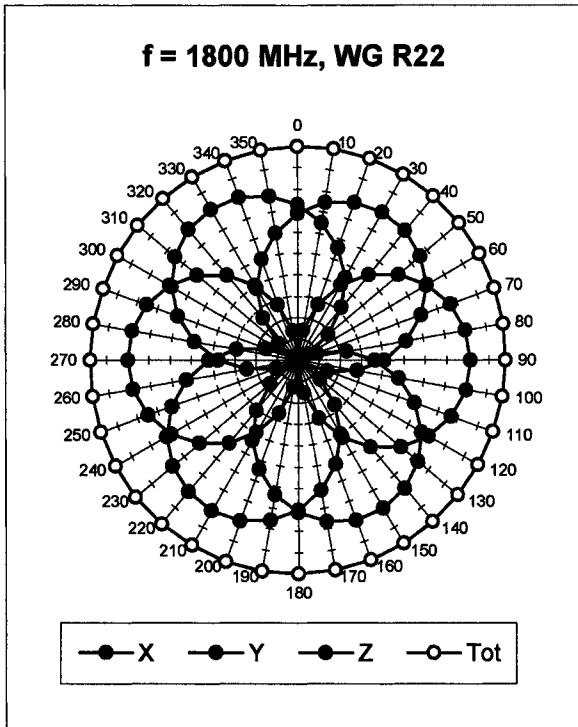

Isotropy Error (ϕ), $\theta = 0^\circ$

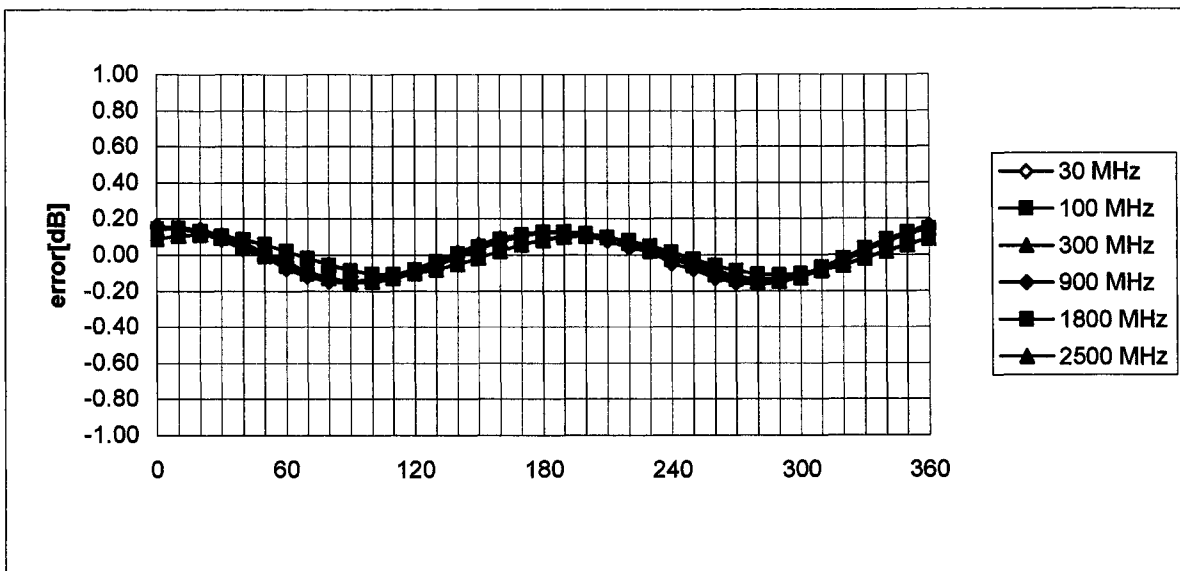

Frequency Response of E-Field

(TEM-Cell:ifi110, Waveguide R22)

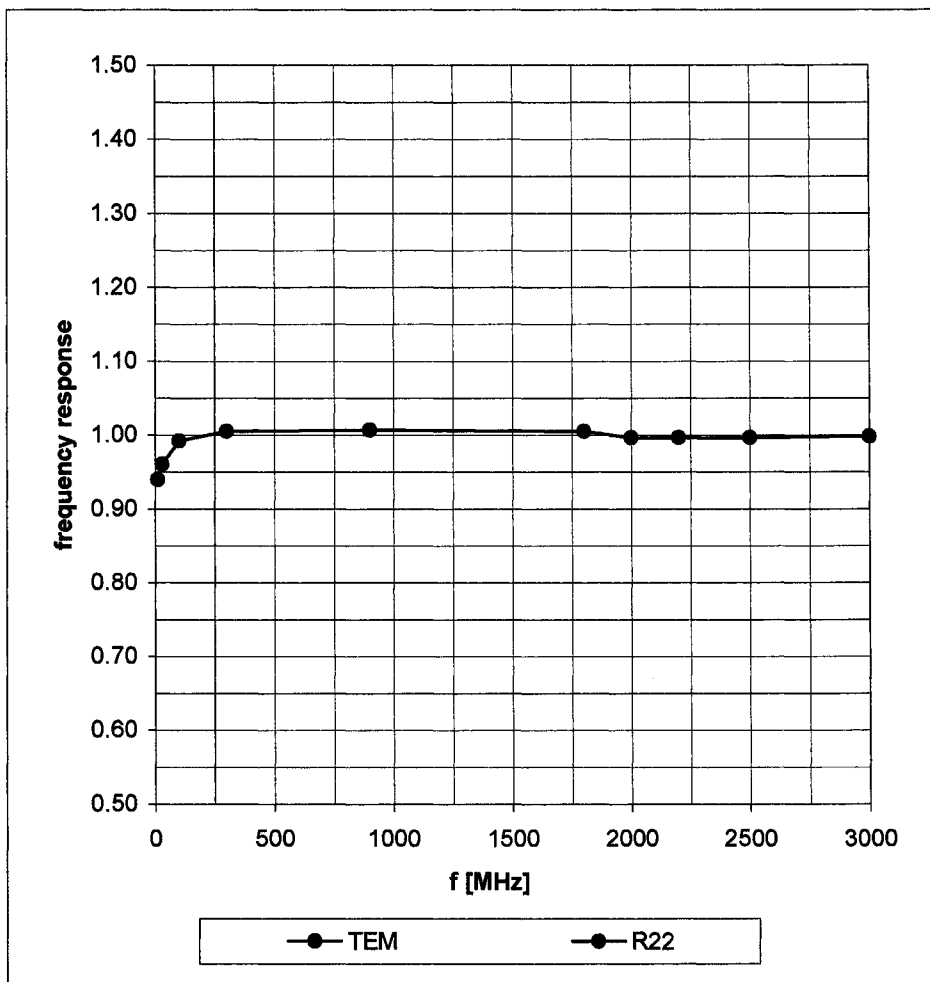

Dynamic Range f(SARhead) (Waveguide R22)

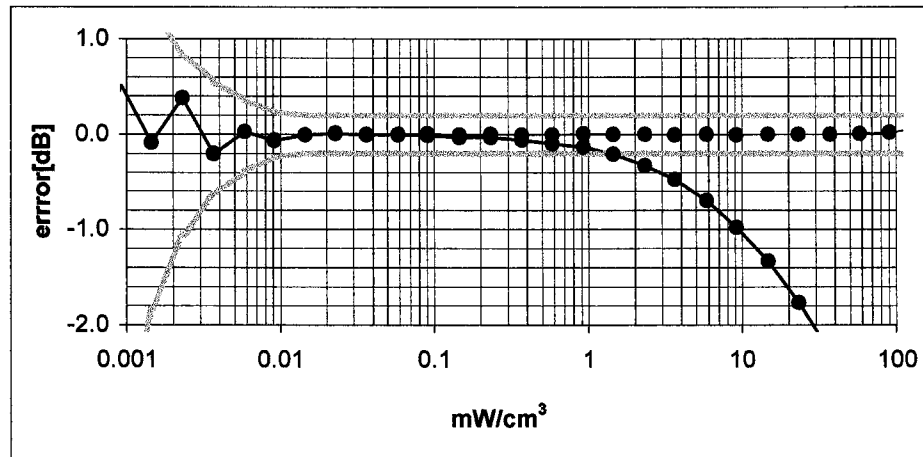
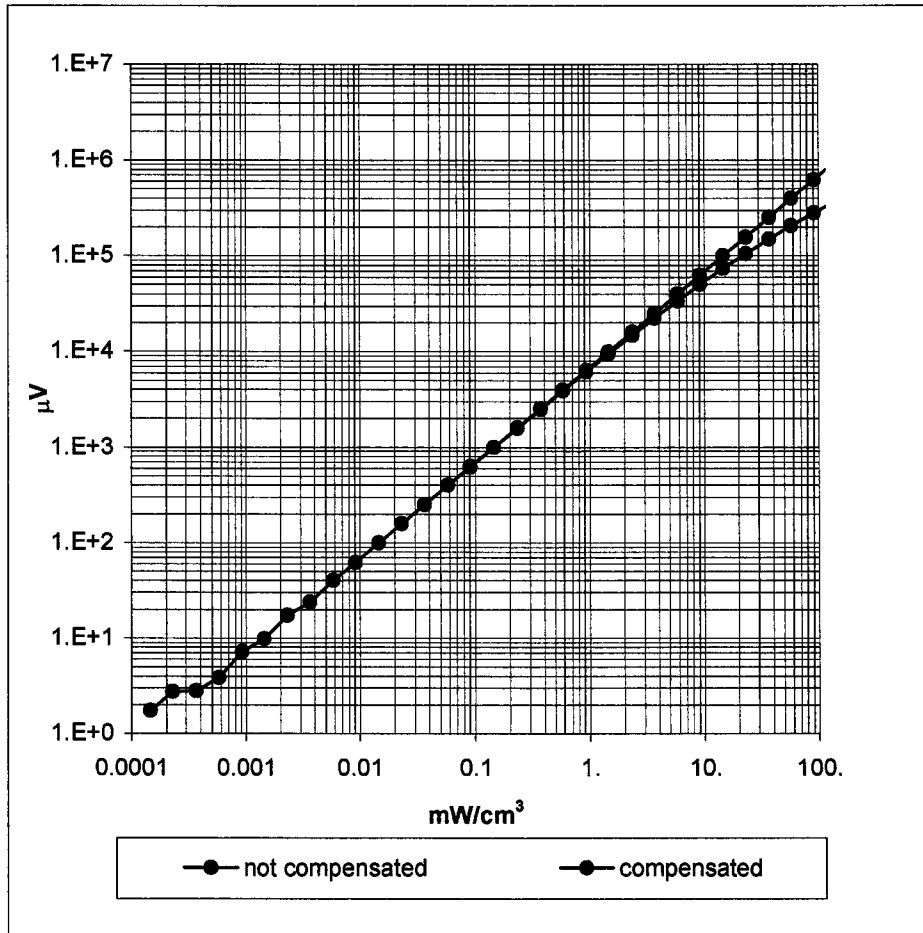

Conversion Factor Assessment

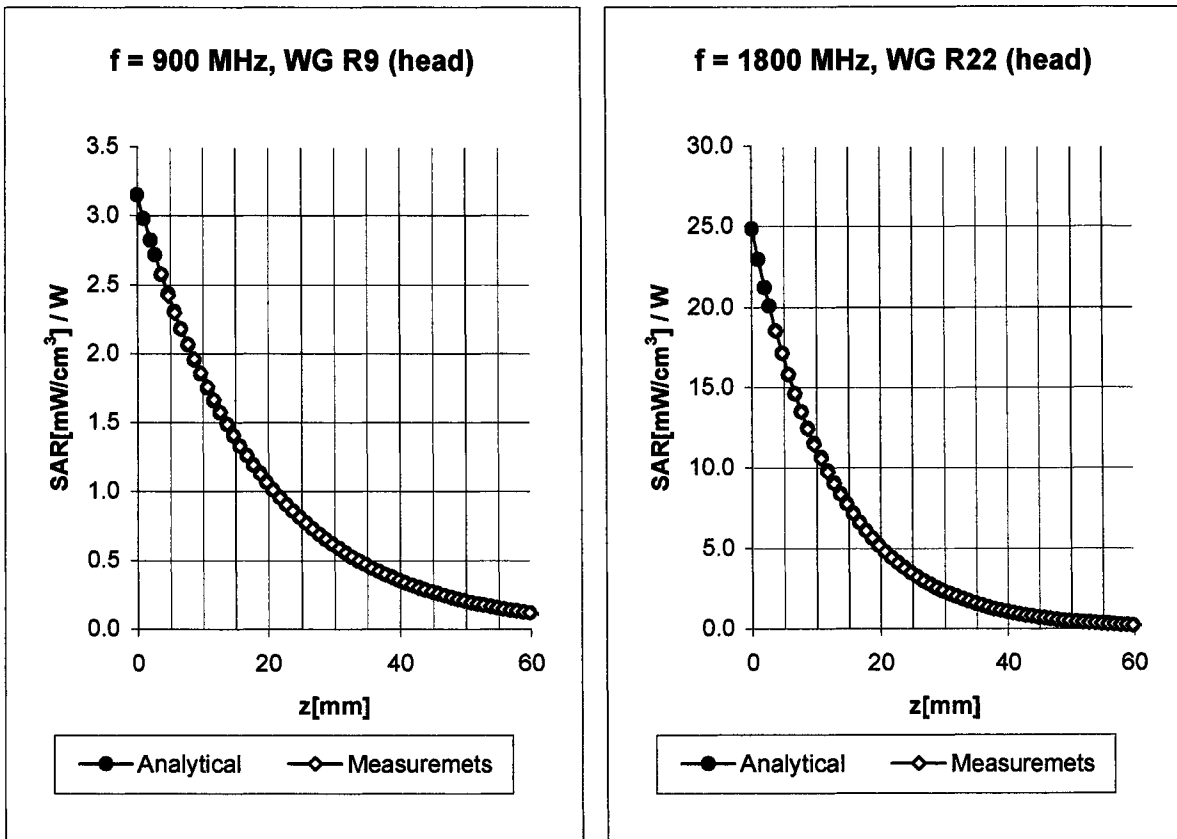

Head 900 MHz $\epsilon_r = 41.5 \pm 5\%$ $\sigma = 0.97 \pm 5\%$ mho/m

Valid for f=800-1000 MHz with Head Tissue Simulating Liquid according to EN 50361, P1528-200X

ConvF X	6.5 $\pm 9.5\%$ (k=2)	Boundary effect:	
ConvF Y	6.5 $\pm 9.5\%$ (k=2)	Alpha	0.53
ConvF Z	6.5 $\pm 9.5\%$ (k=2)	Depth	2.20

Head 1800 MHz $\epsilon_r = 40.0 \pm 5\%$ $\sigma = 1.40 \pm 5\%$ mho/m

Valid for f=1710-1910 MHz with Head Tissue Simulating Liquid according to EN 50361, P1528-200X

ConvF X	5.3 $\pm 9.5\%$ (k=2)	Boundary effect:	
ConvF Y	5.3 $\pm 9.5\%$ (k=2)	Alpha	0.58
ConvF Z	5.3 $\pm 9.5\%$ (k=2)	Depth	2.43

Conversion Factor Assessment

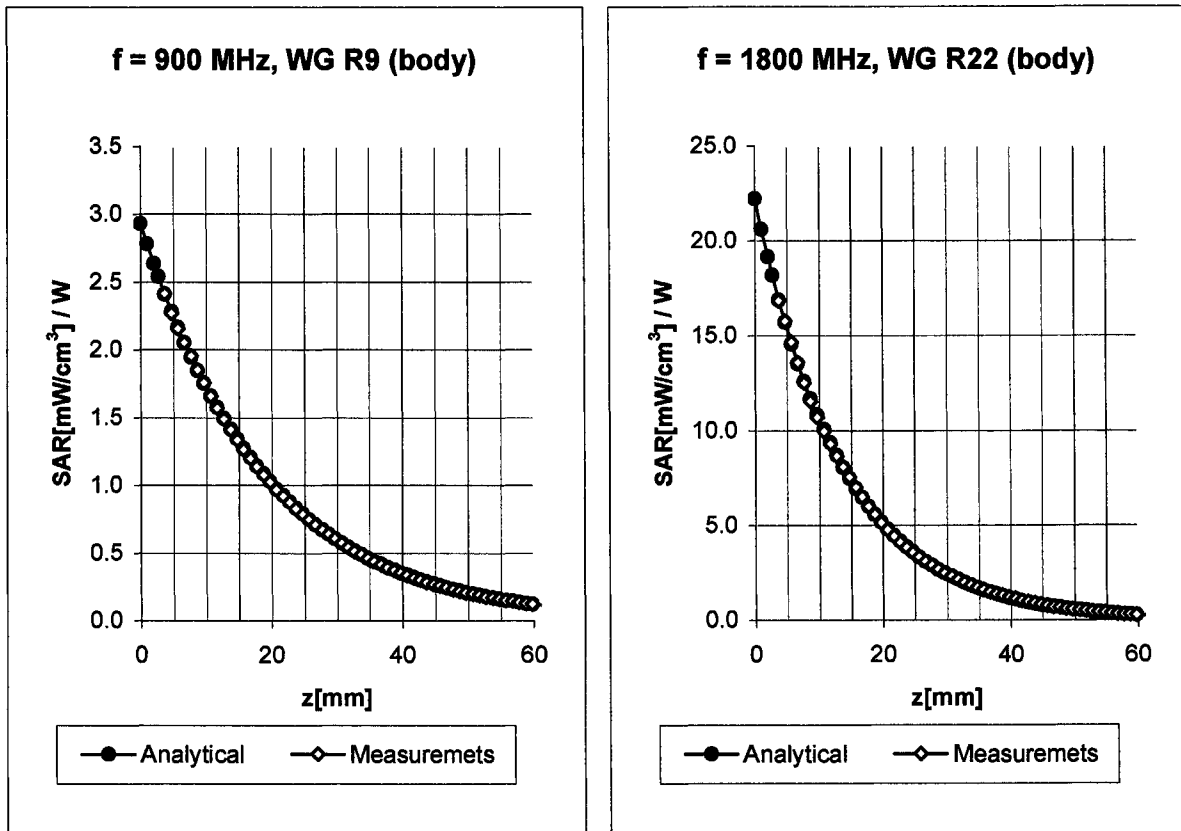

Body **900 MHz** $\epsilon_r = 55.0 \pm 5\%$ $\sigma = 1.05 \pm 5\%$ mho/m

Valid for f=800-1000 MHz with Body Tissue Simulating Liquid according to OET 65 Suppl. C

ConvF X	6.2 \pm 9.5% (k=2)	Boundary effect:
ConvF Y	6.2 \pm 9.5% (k=2)	Alpha 0.51
ConvF Z	6.2 \pm 9.5% (k=2)	Depth 2.36

Body **1800 MHz** $\epsilon_r = 53.3 \pm 5\%$ $\sigma = 1.52 \pm 5\%$ mho/m

Valid for f=1710-1910 MHz with Body Tissue Simulating Liquid according to OET 65 Suppl. C

ConvF X	4.9 \pm 9.5% (k=2)	Boundary effect:
ConvF Y	4.9 \pm 9.5% (k=2)	Alpha 0.71
ConvF Z	4.9 \pm 9.5% (k=2)	Depth 2.35

Conversion Factor Assessment

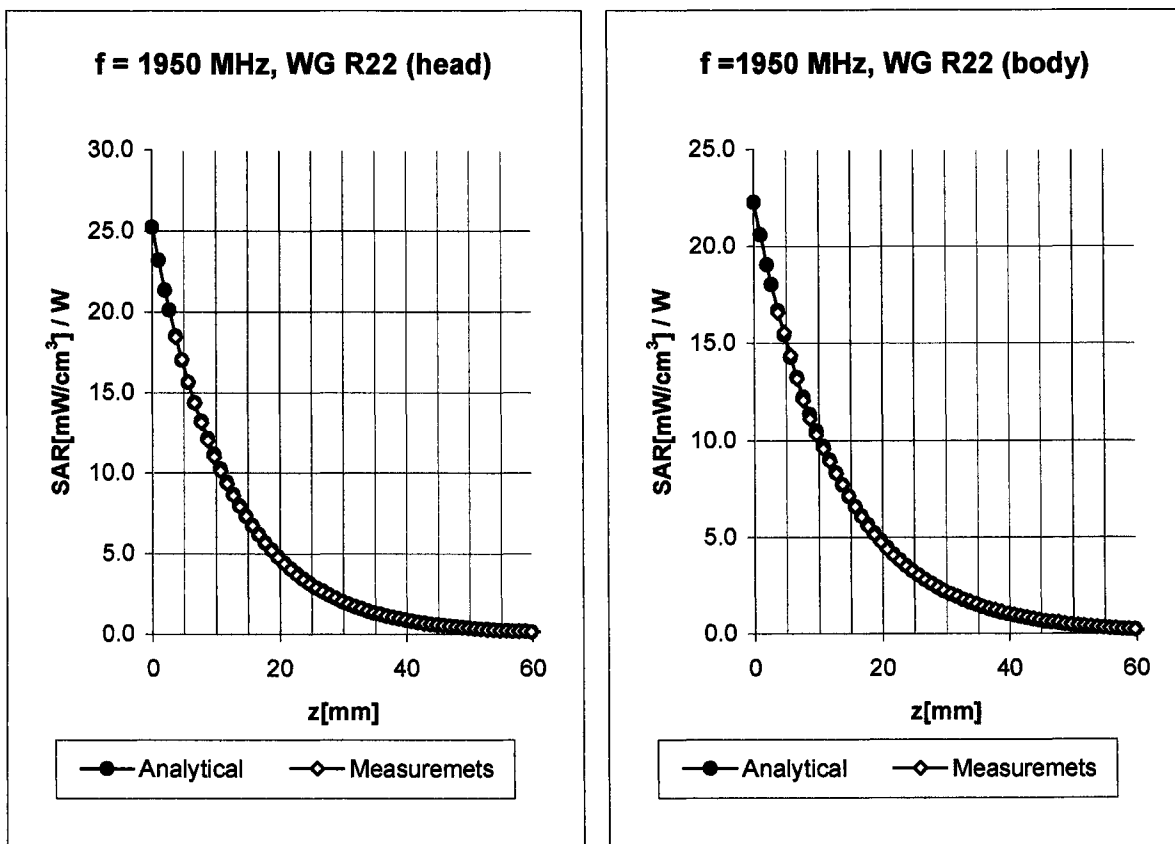

Head **1950 MHz** $\epsilon_r = 40.0 \pm 5\%$ $\sigma = 1.40 \pm 5\%$ mho/m

Valid for f=1900-2000 MHz with Head Tissue Simulating Liquid according to EN 50361, P1528-200X

ConvF X	5.1 $\pm 8.9\%$ (k=2)	Boundary effect:
ConvF Y	5.1 $\pm 8.9\%$ (k=2)	Alpha 0.66
ConvF Z	5.1 $\pm 8.9\%$ (k=2)	Depth 2.29

Body **1950 MHz** $\epsilon_r = 53.3 \pm 5\%$ $\sigma = 1.52 \pm 5\%$ mho/m

Valid for f=1900-2000 MHz with Body Tissue Simulating Liquid according to OET 65 Suppl. C

ConvF X	4.7 $\pm 8.9\%$ (k=2)	Boundary effect:
ConvF Y	4.7 $\pm 8.9\%$ (k=2)	Alpha 0.91
ConvF Z	4.7 $\pm 8.9\%$ (k=2)	Depth 2.00

Deviation from Isotropy in HSL

Error ($\theta\phi$), $f = 900$ MHz

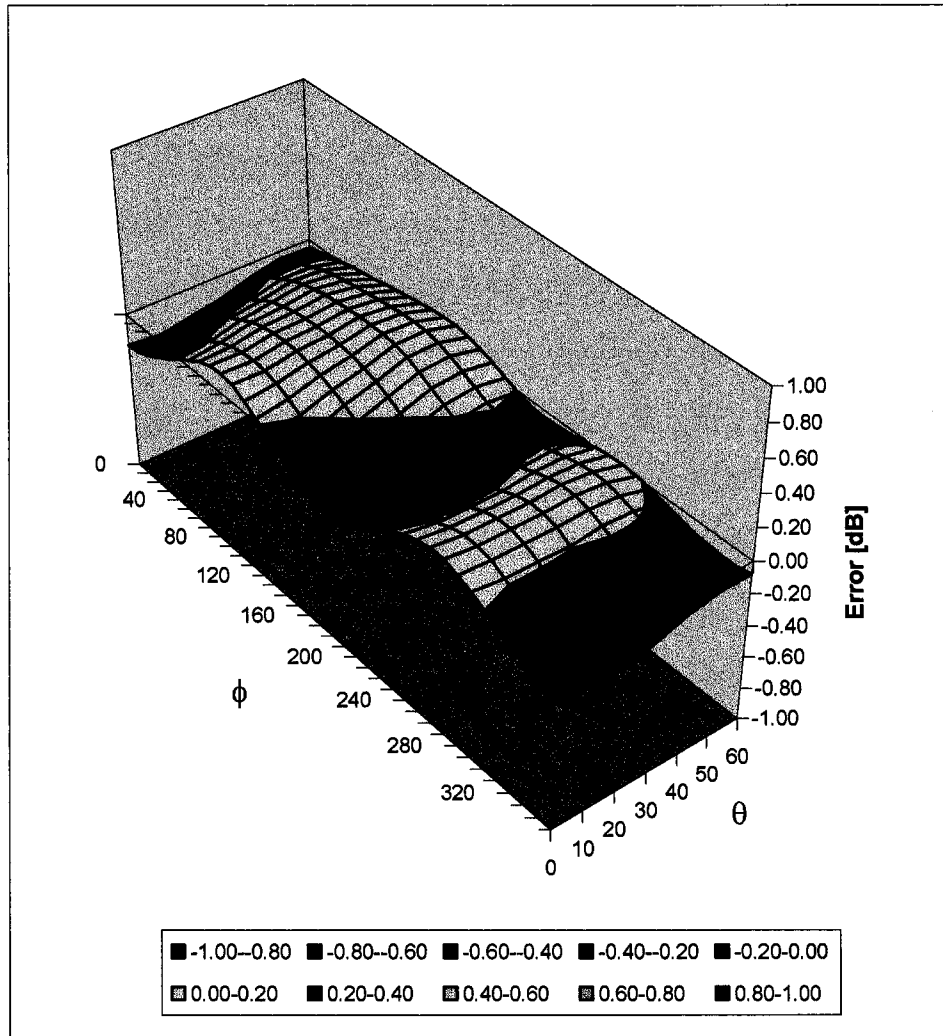

Appendix 5
Dipole Characterization Certificate

Certification of System Performance Check Targets

Based on APP-0396

-Historical Data-

	835MHz	900MHz	1800MHz	1900MHz	
IEEE1528 Target: Advanced Extrapolation	9.5	10.8	38.1	39.7	(W/kg)
Measurement Uncertainty (k=1):	9.0%	9.0%	9.0%	9.0%	
Measurement Period:	1-July-03 to 1-Apr-04	1-July-03 to 1-Apr-04	1-July-03 to 1-Apr-04	1-July-03 to 1-Apr-04	
# of tests performed:	214	1148	1135	62	
Grand Average: Worst Case Extrapolation	10.0	11.4	40.7	42.0	(W/kg)
% Delta (Average - IEEE1528 Target)	5.3%	5.6%	6.8%	5.8%	
Is % Delta <= Measurement Uncertainty?	Yes	Yes	Yes	Yes	
Accept/Reject <u>Average</u> as new system performance check target?	ACCEPT	ACCEPT	ACCEPT	ACCEPT	
	Applicable 835MHz Dipole Serial Numbers:	Applicable 900MHz Dipole Serial Numbers:	Applicable 1800MHz Dipole Serial Numbers:	Applicable 1900MHz Dipole Serial Numbers:	
	420(TR), 421(TR)	77, 78	246(TR), 250(TR)	514(TR), 518(TR)	
	422(TR), 423(TR)	79, 80	251(TR), 258(TR)	519(TR), 520(TR)	
	424(TR), 425(TR)	91, 92	259(TR), 262(TR)	523(TR), 524(TR)	
	431(TR), 432(TR)	93, 94	263(TR), 271(TR)	526(TR), 527(TR)	
	433(TR), 434(TR)	95, 96	272(TR), 273(TR)	528(TR), 529(TR)	
	436(TR)	97, 55	276(TR), 277(TR)	530(TR), 533(TR)	
			279(TR), 280(TR)		
			281(TR), 282(TR)		
			283(TR), 284(TR)		

-New System Performance Check Targets- per APP-0396

(based on analysis of historical data)

Frequency	SAR Target (W/kg)	Permittivity	Conductivity (S/m)
835MHz	10.0	41.5 ± 5%	0.90 ± 5%
900MHz	11.4	41.5 ± 5%	0.97 ± 5%
1800MHz	40.7	40.0 ± 5%	1.40 ± 5%
1900MHz	42.0	40.0 ± 5%	1.40 ± 5%

-Approvals-

Submitted by: Date:

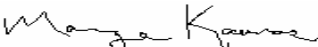
Signed: 

Comments:

Approved by: Date:

Signed: 

Comments:

Appendix 6
Measurement Uncertainty Budget

Uncertainty Budget for Device Under Test									
<i>a</i>	<i>b</i>	<i>c</i>	<i>d</i>	<i>e = f(d,k)</i>	<i>f</i>	<i>g</i>	<i>h = c x f / e</i>	<i>i = c x g / e</i>	<i>k</i>
Uncertainty Component	Sec.	Tol. (± %)	Prob. Dist.	Div.	<i>c_i</i> (1 g)	<i>c_i</i> (10 g)	1 g <i>u_i</i> (±%)	10 g <i>u_i</i> (±%)	<i>v_i</i>
Measurement System									
Probe Calibration	E.2.1	9.5	N	2.00	1	1	4.8	4.8	∞
Axial Isotropy	E.2.2	4.7	R	1.73	0.707	0.707	1.9	1.9	∞
Spherical Isotropy	E.2.2	9.6	R	1.73	0.707	0.707	3.9	3.9	∞
Boundary Effect	E.2.3	5.8	R	1.73	1	1	3.3	3.3	∞
Linearity	E.2.4	4.7	R	1.73	1	1	2.7	2.7	∞
System Detection Limits	E.2.5	1.0	R	1.73	1	1	0.6	0.6	∞
Readout Electronics	E.2.6	1.0	N	1.00	1	1	1.0	1.0	∞
Response Time	E.2.7	0.8	R	1.73	1	1	0.5	0.5	∞
Integration Time	E.2.8	1.3	R	1.73	1	1	0.8	0.8	∞
RF Ambient Conditions	E.6.1	3.0	R	1.73	1	1	1.7	1.7	∞
Probe Positioner Mechanical Tolerance	E.6.2	0.3	R	1.73	1	1	0.2	0.2	∞
Probe Positioning with respect to Phantom Shell	E.6.3	1.1	R	1.73	1	1	0.6	0.6	∞
Extrapolation, interpolation and Integration Algorithms for Max. SAR Evaluation	E.5	3.9	R	1.73	1	1	2.3	2.3	∞
Test sample Related									
Test Sample Positioning	E.4.2	3.6	N	1.00	1	1	3.6	3.6	29
Device Holder Uncertainty	E.4.1	2.8	N	1.00	1	1	2.8	2.8	8
Output Power Variation - SAR drift measurement	6.6.2	5.0	R	1.73	1	1	2.9	2.9	∞
Phantom and Tissue Parameters									
Phantom Uncertainty (shape and thickness tolerances)	E.3.1	4.0	R	1.73	1	1	2.3	2.3	∞
Liquid Conductivity - deviation from target values	E.3.2	5.0	R	1.73	0.64	0.43	1.8	1.2	∞
Liquid Conductivity - measurement uncertainty	E.3.3	10.0	R	1.73	0.64	0.43	3.7	2.5	∞
Liquid Permittivity - deviation from target values	E.3.2	10.0	R	1.73	0.6	0.49	3.5	2.8	∞
Liquid Permittivity - measurement uncertainty	E.3.3	5.0	R	1.73	0.6	0.49	1.7	1.4	∞
Combined Standard Uncertainty			RSS				11.72	11.09	1363
Expanded Uncertainty (95% CONFIDENCE LEVEL)			<i>k</i> =2				22.98	21.75	

Uncertainty Budget for System Performance Check (dipole & flat phantom)

<i>a</i>	<i>b</i>	<i>c</i>	<i>d</i>	<i>e = f(d,k)</i>	<i>f</i>	<i>g</i>	<i>h = c x f / e</i>	<i>i = c x g / e</i>	<i>k</i>
Uncertainty Component	Sec.	Tol. (± %)	Prob. Dist.	Div.	<i>c_i</i> (1 g)	<i>c_i</i> (10 g)	1 g <i>u_i</i> (±%)	10 g <i>u_i</i> (±%)	<i>v_i</i>
Measurement System									
Probe Calibration	E.2.1	9.5	N	2.00	1	1	4.8	4.8	∞
Axial Isotropy	E.2.2	4.7	R	1.73	1	1	2.7	2.7	∞
Spherical Isotropy	E.2.2	9.6	R	1.73	0	0	0.0	0.0	∞
Boundary Effect	E.2.3	5.8	R	1.73	1	1	3.3	3.3	∞
Linearity	E.2.4	4.7	R	1.73	1	1	2.7	2.7	∞
System Detection Limits	E.2.5	1.0	R	1.73	1	1	0.6	0.6	∞
Readout Electronics	E.2.6	1.0	N	1.00	1	1	1.0	1.0	∞
Response Time	E.2.7	0.0	R	1.73	1	1	0.0	0.0	∞
Integration Time	E.2.8	0.0	R	1.73	1	1	0.0	0.0	∞
RF Ambient Conditions	E.6.1	3.0	R	1.73	1	1	1.7	1.7	∞
Probe Positioner Mechanical Tolerance	E.6.2	0.3	R	1.73	1	1	0.2	0.2	∞
Probe Positioning with respect to Phantom Shell	E.6.3	1.1	R	1.73	1	1	0.6	0.6	∞
Extrapolation, interpolation and Integration Algorithms for Max. SAR Evaluation	E.5	3.9	R	1.73	1	1	2.3	2.3	∞
Dipole									
Dipole Axis to Liquid Distance	8, E.4.2	1.0	R	1.73	1	1	0.6	0.6	∞
Input Power and SAR Drift Measurement	8, 6.6.2	4.7	R	1.73	1	1	2.7	2.7	∞
Phantom and Tissue Parameters									
Phantom Uncertainty (shape and thickness tolerances)	E.3.1	4.0	R	1.73	1	1	2.3	2.3	∞
Liquid Conductivity - deviation from target values	E.3.2	5.0	R	1.73	0.64	0.43	1.8	1.2	∞
Liquid Conductivity - measurement uncertainty	E.3.3	10.0	R	1.73	0.64	0.43	3.7	2.5	∞
Liquid Permittivity - deviation from target values	E.3.2	10.0	R	1.73	0.6	0.49	3.5	2.8	∞
Liquid Permittivity - measurement uncertainty	E.3.3	5.0	R	1.73	0.6	0.49	1.7	1.4	∞
Combined Standard Uncertainty			RSS				10.16	9.43	99999
Expanded Uncertainty (95% CONFIDENCE LEVEL)			<i>k</i> =2				19.92	18.48	

Appendix 7

Photographs of the device under test









