



**MOTOROLA**

Exhibit 11: SAR Test Report IHDT6EB1

**Date of test:** 16 – 20 December, 2003  
**Date of Report:** 16 January, 2004

**Laboratory:** Motorola Personal Communications Sector Product Safety & Compliance Laboratory  
 600 N. US Highway 45  
 Room: MW113  
 Libertyville, Illinois 60048

**Test Responsible:** Steven Hauswirth  
 Principal Staff Engineer

**Accreditation:** This laboratory is accredited to ISO/IEC 17025-1999 to perform the following tests:



<p><u>Tests:</u>                  Electromagnetic Specific Absorption Rate</p> <p>Simulated Tissue Preparation                  RF Power Measurement</p>	<p><u>Procedures:</u>                  ANSI/IEEE C95.1-1992, 1999                  (SAR) IEEE C95.3-1991                  IEEE P1528 (<i>DRAFT</i>)                  FCC OET Bulletin 65 (<i>including Supplements A, B, C</i>)                  Australian Communications Authority Radio                  Communications (Electromagnetic Radiation – Human                  Exposure) Standard 1999                  CENELEC EN 50361 (2001)                  APP-0247                  DOI-0876, 0900, 0902, 0904, 0915</p>
------------------------------------------------------------------------------------------------------------------------------------------------------------------	-------------------------------------------------------------------------------------------------------------------------------------------------------------------------------------------------------------------------------------------------------------------------------------------------------------------------------------------------------------------------------------------------------------------------------------------------------------------------------------------------------------------------------------------------------------------------

On the following products or types of products:  
 Wireless Communications Devices (Examples): Two Way Radios; Portable Phones (including Cellular, Licensed Non-Broadcast and PCS); Low Frequency Readers; and Pagers

A2LA certificate #1651-01

**Statement of Compliance:** Motorola declares under its sole responsibility that portable cellular telephone FCC ID IHDT6EB1 to which this declaration relates, is in conformity with the appropriate General Population/Uncontrolled RF exposure standards, recommendations and guidelines (FCC 47 CFR §2.1093). It also declares that the product was tested in accordance with the appropriate measurement standards, guidelines and recommended practices. Any deviations from these standards, guidelines and recommended practices are noted below:

(none)

©Motorola, Inc. 2004

This test report shall not be reproduced except in full, without written approval of the laboratory.

The results and statements contained herein relate only to the items tested. The names of individuals involved may be mentioned only in connection with the statements or results from this report.

Motorola encourages all feedback, both positive and negative, on this test report.

**Table of Contents**

**1. INTRODUCTION..... 3**

**2. DESCRIPTION OF THE DEVICE UNDER TEST ..... 3**

**3. TEST EQUIPMENT USED..... 3**

**3.1 Dosimetric System .....3**

**3.2 Additional Equipment.....4**

**4. ELECTRICAL PARAMETERS OF THE TISSUE SIMULATING LIQUID ..... 4**

**5. SYSTEM ACCURACY VERIFICATION..... 5**

**6. TEST RESULTS ..... 5**

**6.1 Head Adjacent Test Results.....6**

**6.2 Body Worn Test Results .....7**

**APPENDIX 1: SAR DISTRIBUTION COMPARISON FOR SYSTEM ACCURACY VERIFICATION..... 9**

**APPENDIX 2: SAR DISTRIBUTION PLOTS FOR PHANTOM HEAD ADJACENT USE ..... 10**

**APPENDIX 3: SAR DISTRIBUTION PLOTS FOR BODY WORN CONFIGURATION..... 12**

**APPENDIX 4: PROBE CALIBRATION CERTIFICATE ..... 14**

**APPENDIX 5: DIPOLE CHARACTERIZATION CERTIFICATE..... 15**

**APPENDIX 6: MEASUREMENT UNCERTAINTY BUDGET..... 16**

**APPENDIX 7: PHOTOGRAPHS OF DEVICE UNDER TEST ..... 19**

**1. Introduction**

The Motorola Personal Communications Sector Product Safety Laboratory has performed measurements of the maximum potential exposure to the user of portable cellular phone (FCC ID IHDT6EB1). The Specific Absorption Rate (SAR) of this product was measured. The portable cellular phone was tested in accordance with FCC OET Bulletin 65 Supplement C 01-01.

**2. Description of the Device Under Test**

**a. Antenna description**

<b>Type</b>	External	
<b>Location</b>	Upper Right Corner	
<b>Dimensions</b>	Length	20mm
	Width	8mm
<b>Configuration</b>	Helix	

**b. Device Description**

<b>FCC ID Number</b>	IHDT6EB1					
<b>Serial number(s)</b>	1071					
<b>Mode(s) of Operation</b>	GSM 900	GPRS 900	GSM 1800	GPRS 1800	GSM 1900	GPRS 1900
<b>Modulation Mode(s)</b>	GSM	GPRS Class10	GSM	GPRS Class10	GSM	GPRS Class10
<b>Target Value for Maximum Output Power Setting</b>	32.50dBm	32.50dBm	30.60dBm	30.60dBm	30.60dBm	30.60dBm
<b>Duty Cycle</b>	1:8	2:8	1:8	2:8	1:8	2:8
<b>Transmitting Frequency Rang(s)</b>	880.2-914.8MHz	880.2-914.8MHz	1710.2-1784.8MHz	1710.2-1784.8MHz	1850.20-1909.80MHz	1850.20-1909.80MHz
<b>Device Category</b>	Portable					
<b>RF Exposure Limits</b>	General Population / Uncontrolled					

**3. Test Equipment Used**

**3.1 Dosimetric System**

The Motorola Personal Communications Sector Product Safety & Compliance Laboratory utilizes a Dosimetric Assessment System (Dasy3™ v3.1d) manufactured by Schmid & Partner Engineering AG (SPEAG™), of Zurich Switzerland. All the SAR measurements are taken within a shielded enclosure. The overall RSS uncertainty of the measurement system is ±11.7% (K=1) with an expanded uncertainty of ±23.0% (K=2). The measurement uncertainty budget is given in Appendix 6. Per IEEE 1528, this uncertainty budget is applicable to the SAR range of 0.4 W/kg to 10 W/kg. The list of calibrated equipment used for the measurements is shown below.

Description	Serial Number	Cal Due Date
DASY3 DAE V1	SN440	17-Mar-04
E-Field Probe ETDV6	SN1520	9-Jun-04
DASY3 DAE V1	SN378	30-May-04
E-Field Probe ETDV6	SN1514	31-Jul-04
Dipole Validation Kit, DV1800V2	SN281TR	24-Jun-04
S.A.M. Phantom used for 1900MHz	TP-1159	

**3.2 Additional Equipment**

Description	Serial Number	Cal Due Date
Signal Generator HP8648C	3847A04633	11-Oct-04
Power Meter E4419B	GB39511082	19-Apr-04
Power Sensor #1 - 8481A	US39210916	5-Aug-04
Power Sensor #2 - 8481A	US39211008	5-Aug-04
Network Analyzer HP8753ES	US39172529	18-Jun-04
Dielectric Probe Kit HP85070B	US33020235	N/A

**4. Electrical parameters of the tissue simulating liquid**

Prior to conducting SAR measurements, the relative permittivity,  $\epsilon_r$ , and the conductivity,  $\sigma$ , of the tissue simulating liquids were measured with the HP85070 Dielectric Probe Kit. These values, along with the temperature of the tissue simulate are shown in the table below. The recommended limits for maximum permittivity and minimum conductivity are also shown. These come from the Federal Communication Commission, OET Bulletin 65 Supplement C 01-01. It is seen that the measured parameters are satisfactory for compliance testing.

f (MHz)	Tissue type	Limits / Measured	Dielectric Parameters		
			$\epsilon_r$	$\sigma$ (S/m)	Temp (°C)
1880	Head	Measured, 16-Dec-03	38.0	1.45	18.6
		Recommended Limits	40.0 ±5%	1.40 ±5%	18-25
	Body	Measured, 17-Dec-03	51.5	1.59	18.4
		Measured, 20-Dec-03	51.3	1.58	18.8
		Recommended Limits	53.3 ±5%	1.52 ±5%	18-25

The list of ingredients and the percent composition used for the tissue simulates are indicated in the table below.

Ingredient	800MHz Head	800MHz Body	1900MHz Head	1900MHz Body
Sugar	57.0	44.9	--	30.80
DGBE	--	--	47.0	--
Water	40.45	53.06	52.8	68.91
Salt	1.45	0.94	0.2	0.29
HEC	1.0	1.0	--	--
Bact.	0.1	0.1	--	--

## 5. System Accuracy Verification

A system accuracy verification of the DASY3 was performed using the measurement equipment listed in Section 3.1. The daily system accuracy verification occurs within center section of the SAM phantom.

A SAR measurement was performed to see if the measured SAR was within +/- 10% from the target SAR indicated on the dipole certification sheet. These tests were done at 900MHz and/or 1800MHz. These frequencies are within 100MHz of the mid-band frequency of the test device. This is within the allowable window given in Supplement C 01-01 *Appendix D System Verification* section item #5. The test was conducted on the same days as the measurement of the DUT. Recommended limits for maximum permittivity, minimum conductivity are shown in the table below. These come from the Federal Communication Commission, OET Bulletin 65 Supplement C 01-01. The obtained results from the system accuracy verification are displayed in the table below. The distributions of SAR compare well with those of the reference measurements (see Appendix 1). The tissue stimulant depth was verified to be 15.0cm ±0.5cm. Z-axis scans showing the SAR penetration are also included in Appendix 1. SAR values are normalized to 1W forward power delivered to the dipole.

f (MHz)	Description	SAR (W/kg), 1gram	Dielectric Parameters		Ambien t Temp (°C)	Tissue Temp (°C)
			ε <sub>r</sub>	σ (S/m)		
1800	Measured, 16-Dec-03	41.9	38.4	1.37	20	19.0
	Measured, 17-Dec-03	41.3	38.6	1.34	20	19.5
	Measured, 20-Dec-03	41.0	38.8	1.36	20	19.1
	<b>Recommended Limits</b>	39.7	40.0 ±5%	1.4 ±5%	18-25	18-25

The following probe conversion factors were used on the E-Field probe(s) used for the system accuracy verification measurements:

Description	Serial Number	f (MHz)	Conversion Factor	Cal Cert pg #
E-Field Probe ET3DV6	SN1520	1800	5.10	7 of 9
E-Field Probe ET3DV6	SN1514	1800	5.10	7 of 11

## 6. Test Results

The test sample was operated in a test mode that allows control of the transmitter without the need to place actual phone calls. For the purposes of this test the unit is commanded to test mode and manually set to the proper channel, transmitter power level and transmit mode of operation. The phone was tested in the configurations stipulated in OET Bulletin 65 Supplement C 01-01. Motorola also followed the requirements in Supplement. C / Appendix D: SAR Measurement Procedures, section titled “*Devices Operating Next To A Person’s Ear* “. These directions state “The device should be tested on the left and right side of the head phantom in the “Cheek/Touch” and “Ear/Tilt” positions. When applicable, each configuration should be tested with the antenna in its fully extended and fully retracted positions. These test configurations should be tested at the high, middle and low frequency channels of each operating mode; for example, AMPS, CDMA, and TDMA. If the SAR measured at the middle channel for each test configuration (left, right, Cheek/Touch, Tile/Ear, extended and retracted) is at least 2.0 dB lower than the SAR limit, testing at the high and low channels is optional for such test configuration(s).“

The DASY v3.1d SAR measurement system specified in section 3.1 was utilized within the intended operations as set by the SPEAG™ setup. The phone was positioned into the measurement configurations using the positioner supplied with the DASY 3.1d SAR measurement system. The measured dielectric constant of the material used for the positioner is less than 2.9 and the loss tangent is less than 0.02 (± 30%) at 850MHz. The default settings for the “coarse” and “cube” scans were chosen and use for measurements. The grid spacing of the course scan was set to

15cm as shown in the SAR plots included in appendix 2 and 3. Please refer to the DASY manual for additional information on SAR scanning procedures and algorithms used.

The Cellular Phone model V878 has the SNN5734A as the only available battery option. This battery was used to do all of the SAR testing. The phone was placed in the SAR measurement system with a fully charged battery.

### 6.1 Head Adjacent Test Results

To aid in positioning repeatability, the ear reference line of the device and the axis reference line of the device have been physically added using a non-metallic marker.

- Per Figure 1, the "Ear Reference Line" is centered vertically through the center of the listening area (as defined by the speaker holes in the housing).
- The "Axis Reference Line" bisects the front surface of the device at its top and bottom edges.
- The intersection of these two lines defines the location of the "Ear Reference Point".

The lines drawn on the device extended to the outside edges, as shown in blue in the figure below, & wrap around the sides of the device.

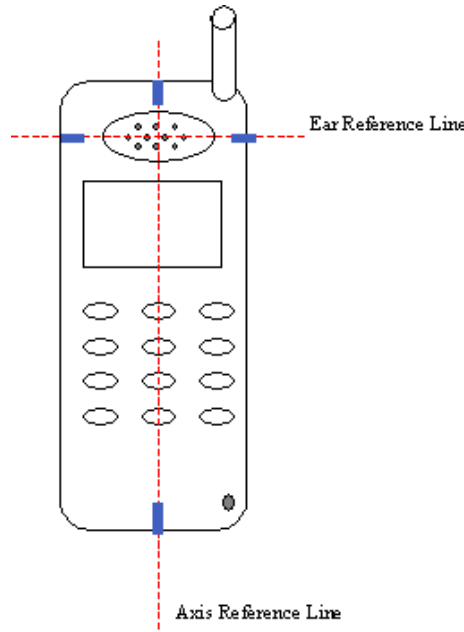

The SAR results shown in tables 1 and 2 are maximum SAR values averaged over 1 gram of phantom tissue. Also shown are the measured conducted output powers, the temperature of the test facility during the test, the temperature of the tissue simulate after the test, the measured drift and the extrapolated SAR. The exact method of extrapolation is  $\text{New SAR} = \text{Old SAR} * 10^{(-\text{drift}/10)}$ . The SAR reported at the end of the measurement process by the DASY™ measurement system can be scaled up by the measured drift to determine the SAR at the beginning of the measurement process. This is the most conservative SAR because it corresponds to the average output power at the beginning of the SAR test. This extrapolation has been done because when the DUT is operating properly it may exhibit a slump in radiated power and SAR over time. This is verified by measuring the SAR drift after the test. The test conditions indicated as bold numbers in the following table are included in Appendix 2

The SAR measurements were performed using the SAM phantoms listed in section 3.1. Since same phantoms and tissue simulate are used for the system accuracy verification as the device SAR measurements, the Z-axis scans included in within Appendix 1 are applicable for verification of tissue simulate depth to be 15.0cm ±0.5cm. All other test conditions measured lower SAR values than those included in Appendix 2.

The following probe conversion factors were used on the E-Field probe(s) used for the head adjacent measurements:

Description	Serial Number	f (MHz)	Conversion Factor	Cal Cert pg #
E-Field Probe ET3DV6	SN1520	1800	5.10	7 of 9

			Cheek Position SAR, 1g							
f (MHz)	Description	Conducted Output Power (dBm)	Left Head				Right Head			
			Measured (W/kg)	Drift (dB)	Extrapolated (W/kg)	Temp (°C)	Measured (W/kg)	Drift (dB)	Extrapolated (W/kg)	Temp (°C)
1900MHz	Channel 512	30.50								
	Channel 661	30.56	<b>0.741</b>	<b>-0.09</b>	<b>0.76</b>	<b>18.6</b>	0.648	-0.23	0.68	18.6
	Channel 810	30.51								

**Table 1: SAR measurement results for the portable cellular telephone FCC ID IHDT6EB1 at highest possible output power. Measured against the right head in the Cheek/Touch Position.**

			15° Tilt Position SAR, 1g							
f (MHz)	Description	Conducted Output Power (dBm)	Left Head				Right Head			
			Measured (W/kg)	Drift (dB)	Extrapolated (W/kg)	Temp (°C)	Measured (W/kg)	Drift (dB)	Extrapolated (W/kg)	Temp (°C)
1900MHz	Channel 512	30.50								
	Channel 661	30.56	<b>0.112</b>	<b>0.05</b>	<b>0.11</b>	<b>18.6</b>	0.0988	0.13	0.10	18.6
	Channel 810	30.51								

**Table 2: SAR measurement results for the portable cellular telephone FCC ID IHDT6EB1 at highest possible output power. Measured against the right head in the 15° Tilt Position.**

### 6.2 Body Worn Test Results

The SAR results shown in tables 3 and 4 are the maximum SAR values averaged over 1 gram of phantom tissue. Also shown are the measured conducted output powers, the temperature of the test facility during the test, the temperature of the tissue simulate after the test, the measured drift and the extrapolated SAR. The exact method of extrapolation is  $New\ SAR = Old\ SAR * 10^{(-drift/10)}$ . The SAR reported at the end of the measurement process by the DASY™ measurement system can be scaled up by the measured drift to determine the SAR at the beginning of the measurement process. This is the most conservative SAR because it corresponds to the average output power at the beginning of the SAR test. This extrapolation has been done because when the DUT is operating properly it may exhibit a slump in radiated power and SAR over time. This is verified by measuring the SAR drift after the test. The test conditions indicated as bold numbers in the following table are included in Appendix 3. Note that 800MHz digital mode SAR measurements were performed in accordance with OET Bulletin 65 Supplement C 01-01. All other test conditions measured lower SAR values than those included in Appendix 3.

A “flat” phantom was for the body-worn tests. This “flat” phantom is made out of 1” thick natural High Density Polyethylene with a thickness at the bottom equal to 2.0mm. It measures 52.7cm(long) x 26.7cm(wide) x 21.2cm(tall). The measured dielectric constant of the material used is less than 2.3 and the loss tangent is less than 0.0046 all the way up to 2.184GHz.

The tissue stimulant depth was verified to be 15.0cm ±0.5cm. The same device holder described in section 6 was used for positioning the phone. The functional accessories were divided into two categories, the ones with metal components and the ones with non-metal components. For non-metallic component accessories, testing was performed on the accessory that displayed the closest proximity to the flat phantom. Each metallic component accessory, if any, was checked for uniqueness of metal component so that each is tested with the device. If multiple accessories shared an identical metal component, only the accessory that dictates the closest spacing to the body was tested. The cellular phone was tested with a headset connected to the device for all body-worn SAR measurements.

There are no Body-Worn Accessories available for this phone. The phone was tested in the body configuration per Supplement C.

The following probe conversion factors were used on the E-Field probe(s) used for the body worn measurements:

Description	Serial Number	f (MHz)	Conversion Factor	Cal Cert pg #
E-Field Probe ET3DV6	SN1514	1800	4.7	8 of 11
E-Field Probe ET3DV6	SN1520	1800	4.8	8 of 9

f (MHz)	Description	Conducted Output Power (dBm)	Body Worn								
			15mm Separation between Phantom and Front of Phone				15mm Separation between Phantom and Back of Phone				
			Measured (W/kg)	Drift (dB)	Extrapolated (W/kg)	Simulate Temp (°C)	Measured (W/kg)	Drift (dB)	Extrapolated (W/kg)	Simulate Temp (°C)	
1900MHz	Channel 512	30.50									
	Channel 661	30.56	0.207	-0.02	0.21	18.4	0.612	-0.11	0.63	18.4	
	Channel 810	30.51									

**Table 3: SAR measurement results for the portable cellular telephone FCC ID IHDT6EB1 at highest possible output power. Measured against the body.**

f (MHz)	Description	Conducted Output Power (dBm)	GPRS Class 10 Body Worn								
			25mm Separation between Phantom and Front of Phone				25mm Separation between Phantom and Back of Phone				
			Measured (W/kg)	Drift (dB)	Extrapolated (W/kg)	Simulate Temp (°C)	Measured (W/kg)	Drift (dB)	Extrapolated (W/kg)	Simulate Temp (°C)	
1900MHz	Channel 512	30.50									
	Channel 661	30.56	0.175	0.0	0.18	18.8	0.389	-0.1	0.40	18.9	
	Channel 810	30.51									

**Table 4: SAR measurement results for the portable cellular telephone FCC ID IHDT6EB1 at highest possible output power. Measured against the body.**

## **Appendix 1**

### **SAR distribution comparison for the system accuracy verification**

# Dipole 1800 MHz

1800 MHz System Performance Check / Dipole Sn# 281TR

Forward Power = 253mW    Reflected Power = -30.82dB

Room Temp at time of measurement = 20C    Simulant Temp at time of measurement = 19.0C

R3 Amy Twin Phantom Rev.4 (22Aug02); section 1

Probe: ET3DV6 - SN1520 - Validation.2; ConvF(5.10,5.10,5.10); Crest factor: 1.0; 1800 MHz VALIDATION:  $\sigma = 1.37$  mho/m  $\epsilon_r = 38.4$   $\rho = 1.00$  g/cm<sup>3</sup>

Cubes (2): Peak: 19.4 mW/g  $\pm 0.06$  dB, SAR (1g): 10.6 mW/g  $\pm 0.02$  dB, SAR (10g): 5.62 mW/g  $\pm 0.01$  dB, (Worst-case extrapolation)

Penetration depth: 8.6 (8.2, 9.4) [mm]

Powerdrift: -0.04 dB

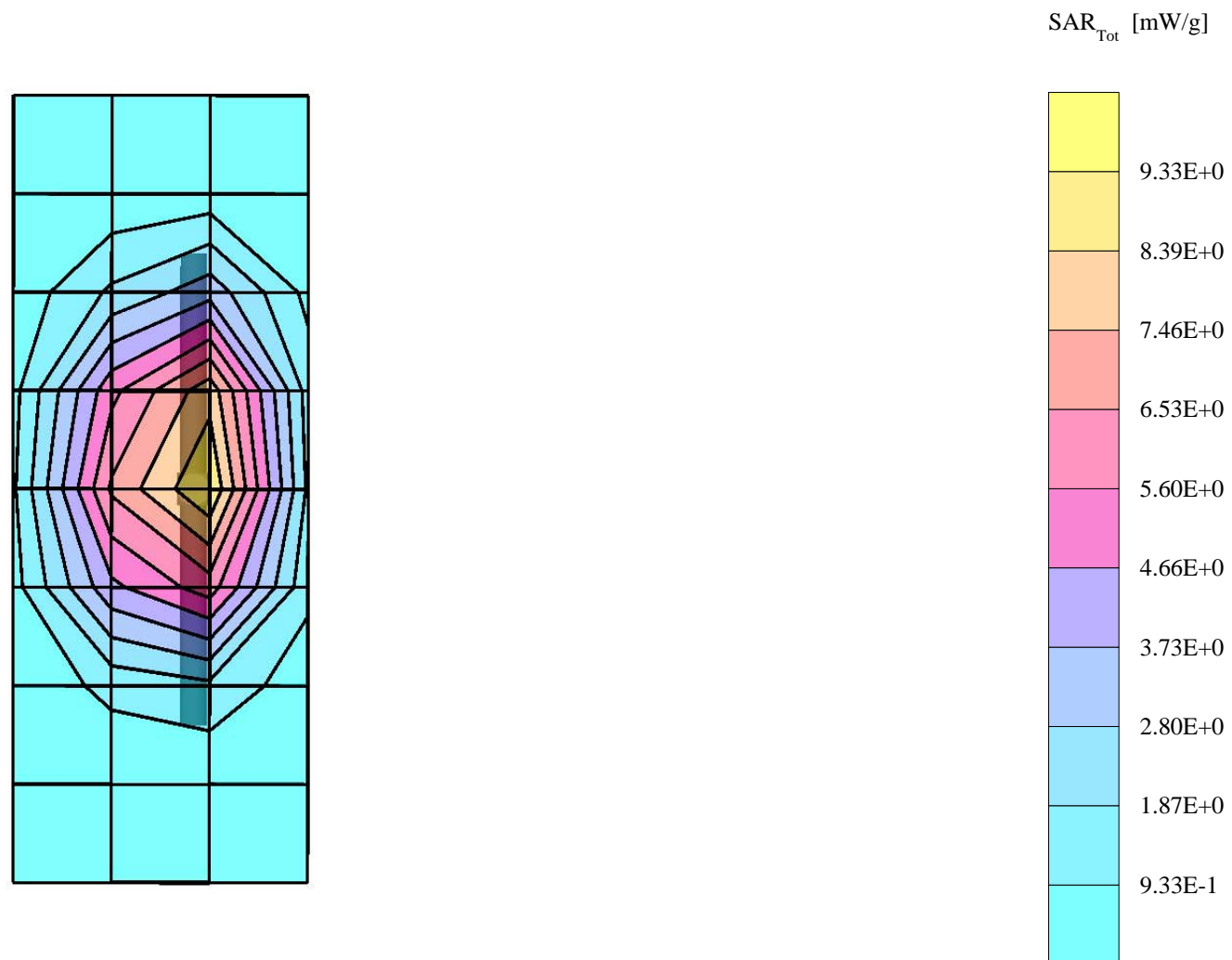

# Dipole 1800 MHz

1800 MHz System Performance Check / Dipole Sn# 281TR

Forward Power = 253mW Reflected Power = -30.82dB

Room Temp at time of measurement = 20C Simulant Temp at time of measurement = 19.0C

R3 Amy Twin Phantom Rev.4 (22Aug02) Phantom; Section; Position: ; Frequency: 1800 MHz

Probe: ET3DV6 - SN1520 - Validation.2; ConvF(5.10,5.10,5.10); Crest factor: 1.0; 1800 MHz VALIDATION:  $\sigma = 1.37$  mho/m  $\epsilon_r = 38.4$   $\rho = 1.00$  g/cm<sup>3</sup>

: , ()

Z-Axis: Dx = 0.0, Dy = 0.0, Dz = 5.0

Penetration depth: 8.3 (8.0, 9.1) [mm]

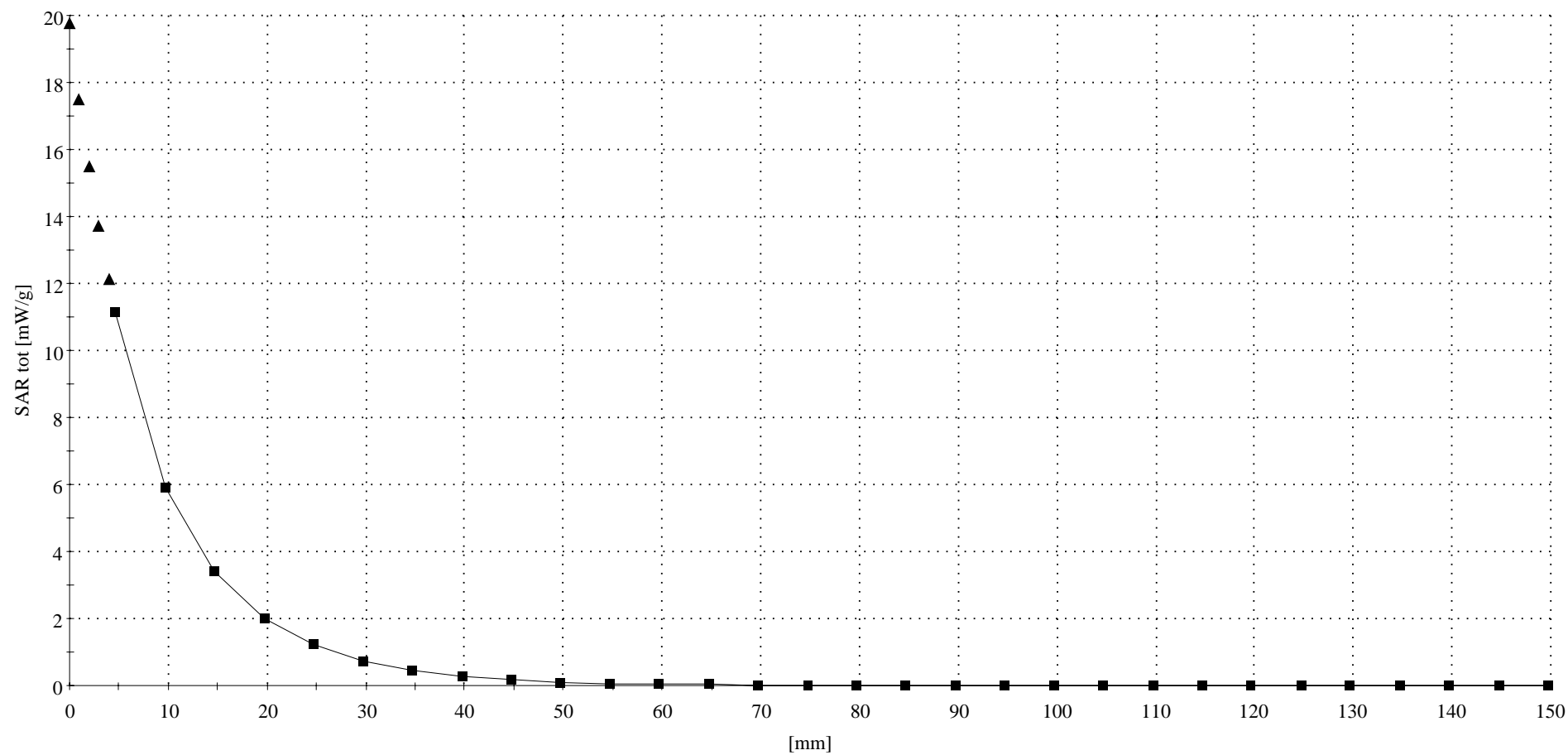

# Dipole 1800 MHz

900 MHz System Performance Check / Dipole Sn# 281TR

Forward Power = 252mW      Reflected Power = -29.92dB

Room Temp at time of measurement = 20C      Simulant Temp at time of measurement = 19.5C

R3 Amy Twin Phantom Rev.4 (22Aug02); section 1

Probe: ET3DV6 - SN1520 - Validation.2; ConvF(5.10,5.10,5.10); Crest factor: 1.0; 1800 MHz VALIDATION:  $\sigma = 1.34$  mho/m  $\epsilon_r = 38.6$   $\rho = 1.00$  g/cm<sup>3</sup>

Cubes (2): Peak: 19.0 mW/g  $\pm 0.04$  dB, SAR (1g): 10.4 mW/g  $\pm 0.01$  dB, SAR (10g): 5.46 mW/g  $\pm 0.01$  dB, (Worst-case extrapolation)

Penetration depth: 8.4 (8.1, 9.2) [mm]

Powerdrift: 0.02 dB

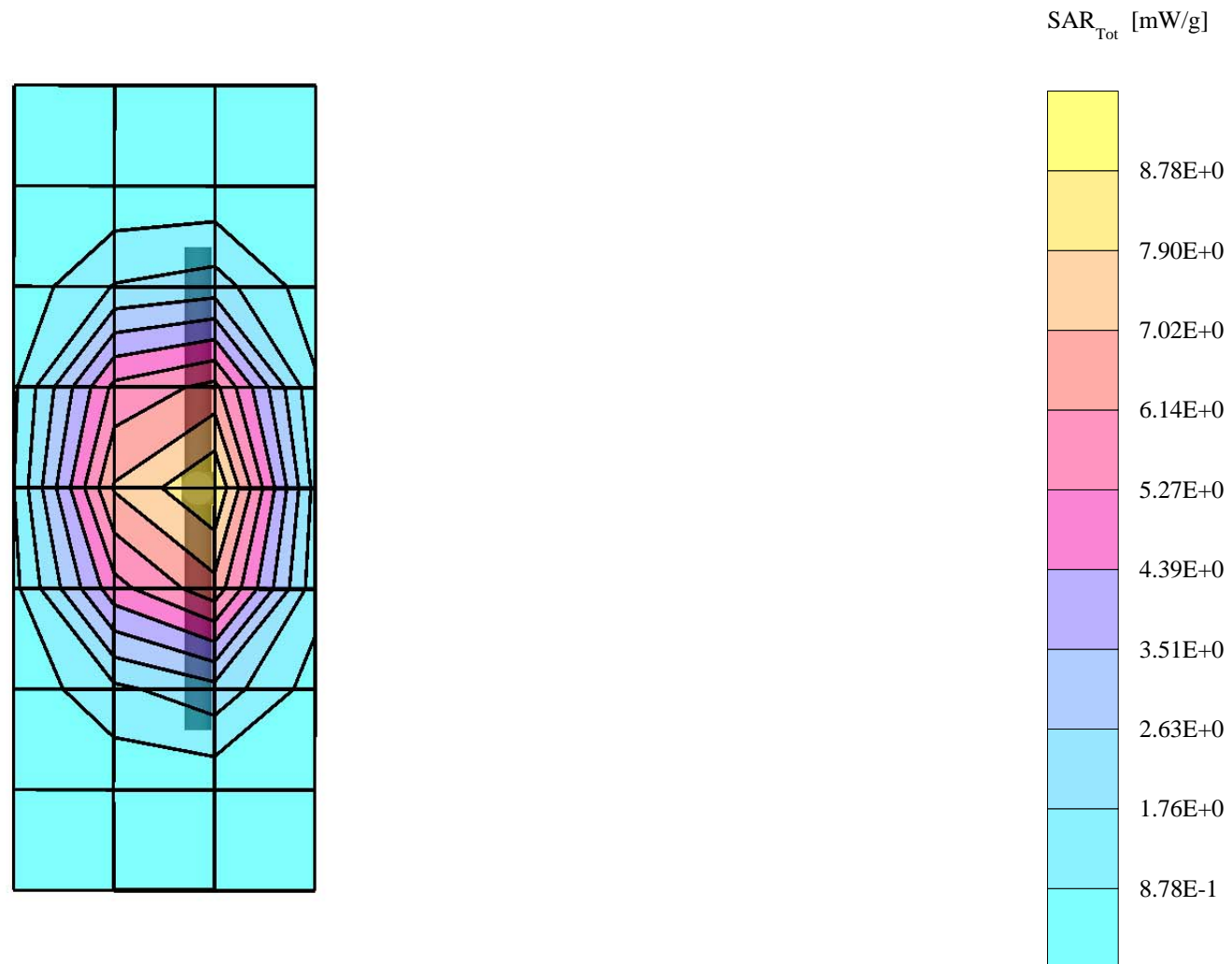

# Dipole 1800 MHz

900 MHz System Performance Check / Dipole Sn# 281TR

Forward Power = 252mW      Reflected Power = -29.92dB

Room Temp at time of measurement = 20C      Simulant Temp at time of measurement = 19.5C

R3 Amy Twin Phantom Rev.4 (22Aug02) Phantom; Section; Position; ; Frequency: 1800 MHz

Probe: ET3DV6 - SN1520 - Validation.2; ConvF(5.10,5.10,5.10); Crest factor: 1.0; 1800 MHz VALIDATION:  $\sigma = 1.34$  mho/m  $\epsilon_r = 38.6$   $\rho = 1.00$  g/cm<sup>3</sup>

: , ()

Z-Axis: Dx = 0.0, Dy = 0.0, Dz = 5.0

Penetration depth: 8.3 (7.9, 9.1) [mm]

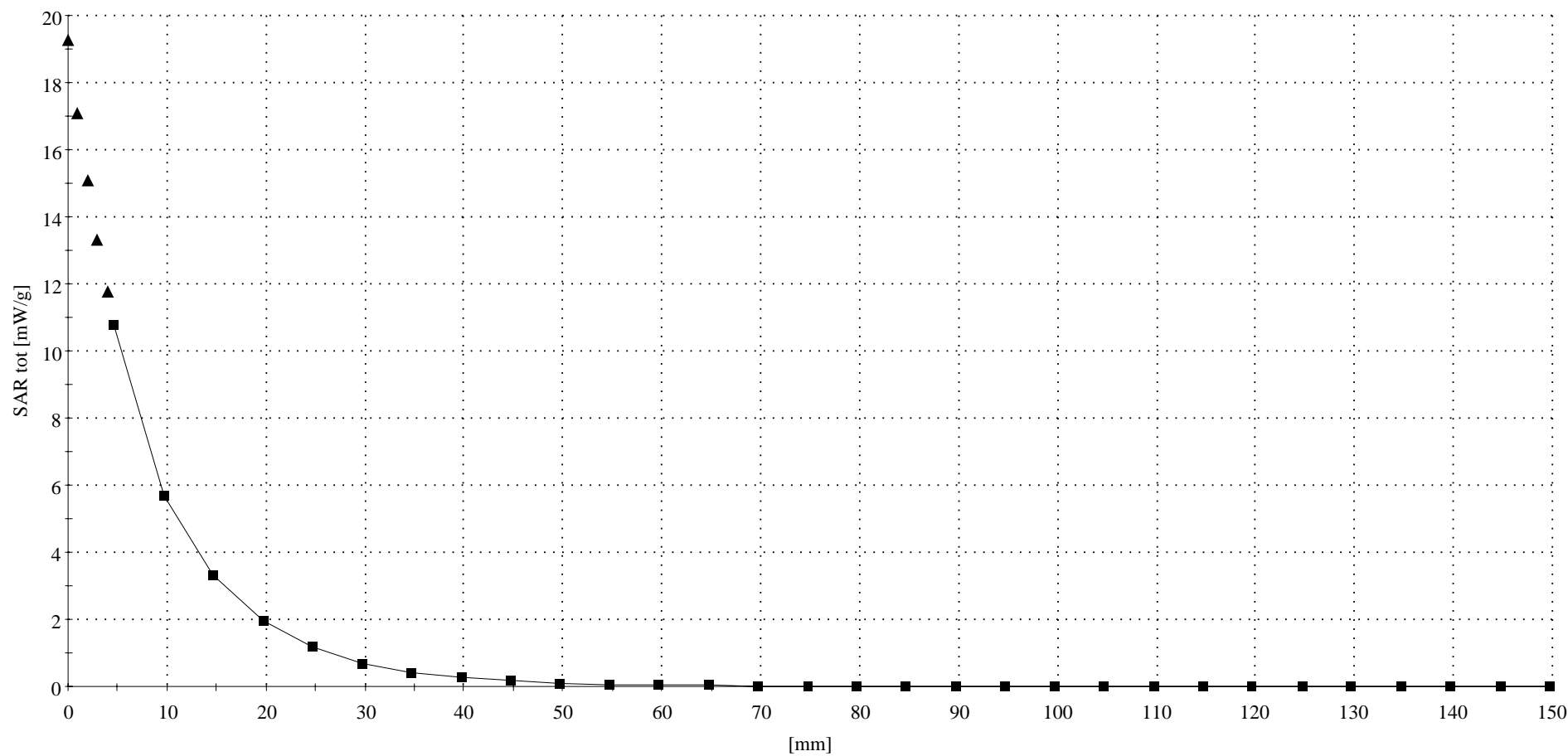

# Dipole 1800 MHz

1800 MHz System Performance Check / Dipole Sn# 272tr

Forward Power = 249mW Reflected Power = -25.60dB

Room Temp at time of measurement = 20.0C Simulant Temp at time of measurement = 19.1C

R4 TP-1250 GLYCOL sam expanded (Rev. 2)-9Jan03; Flat

Probe: ET3DV6 - SN1514 - Validation.3; ConvF(5.10,5.10,5.10); Crest factor: 1.0; 1800 MHz VALIDATION:  $\sigma = 1.36$  mho/m  $\epsilon_r = 38.8$   $\rho = 1.00$  g/cm<sup>3</sup>

Cubes (2): Peak: 18.7 mW/g  $\pm 0.03$  dB, SAR (1g): 10.2 mW/g  $\pm 0.00$  dB, SAR (10g): 5.39 mW/g  $\pm 0.03$  dB, (Worst-case extrapolation)

Penetration depth: 8.3 (7.9, 9.1) [mm]

Powerdrift: 0.05 dB

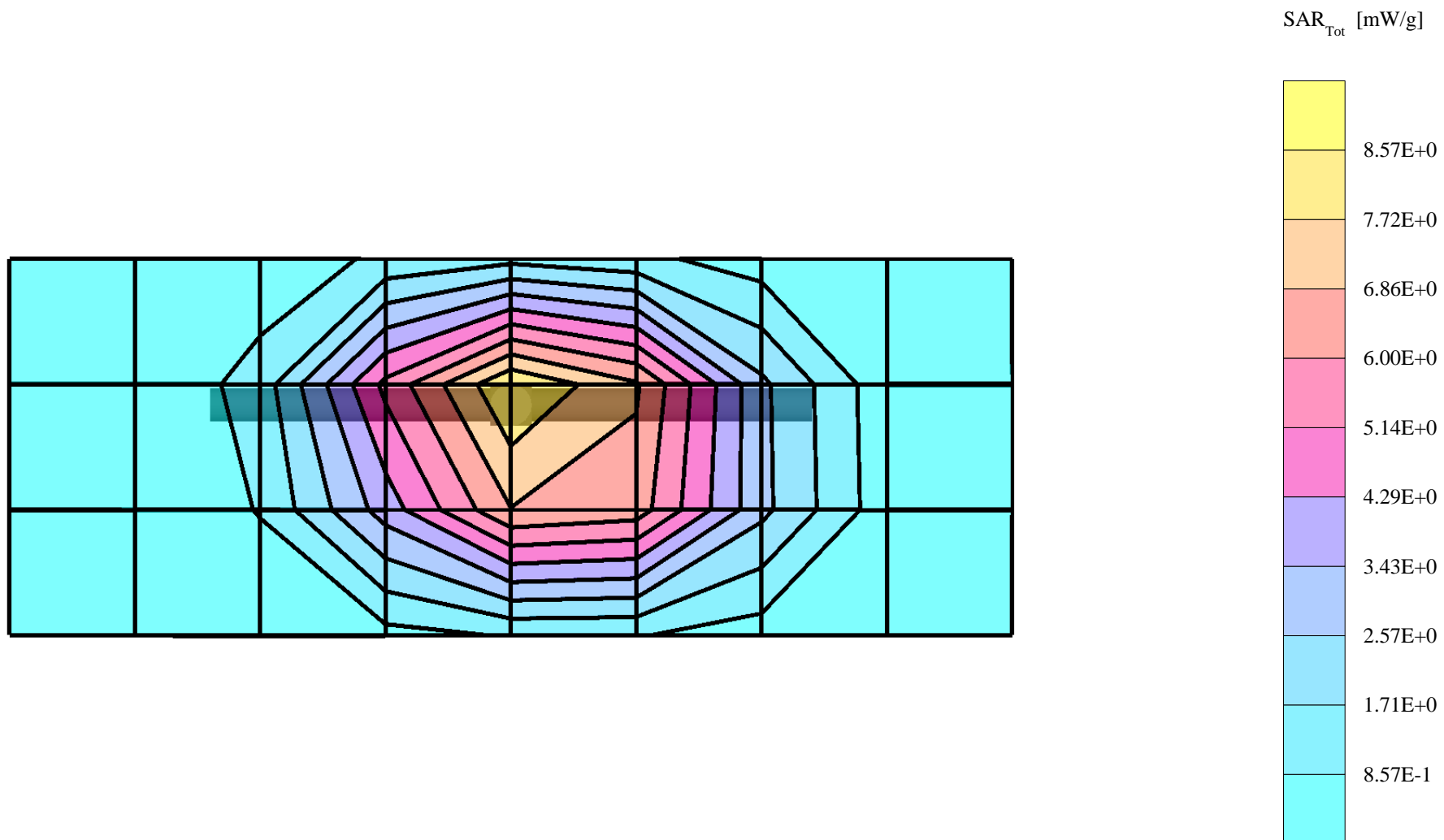

# Dipole 1800 MHz

1800 MHz System Performance Check / Dipole Sn# 272tr

Forward Power = 249mW      Reflected Power = -25.60dB

Room Temp at time of measurement = 20.0C      Simulant Temp at time of measurement = 19.1C

R4 TP-1250 GLYCOL sam expanded (Rev. 2)-9Jan03 Phantom; Section; Position: ; Frequency: 1800 MHz

Probe: ET3DV6 - SN1514 - Validation.3; ConvF(5.10,5.10,5.10); Crest factor: 1.0; 1800 MHz VALIDATION:  $\sigma = 1.36$  mho/m  $\epsilon_r = 38.8$   $\rho = 1.00$  g/cm<sup>3</sup>

: , ()

Z-Axis: Dx = 0.0, Dy = 0.0, Dz = 5.0

Penetration depth: 8.2 (7.8, 9.1) [mm]

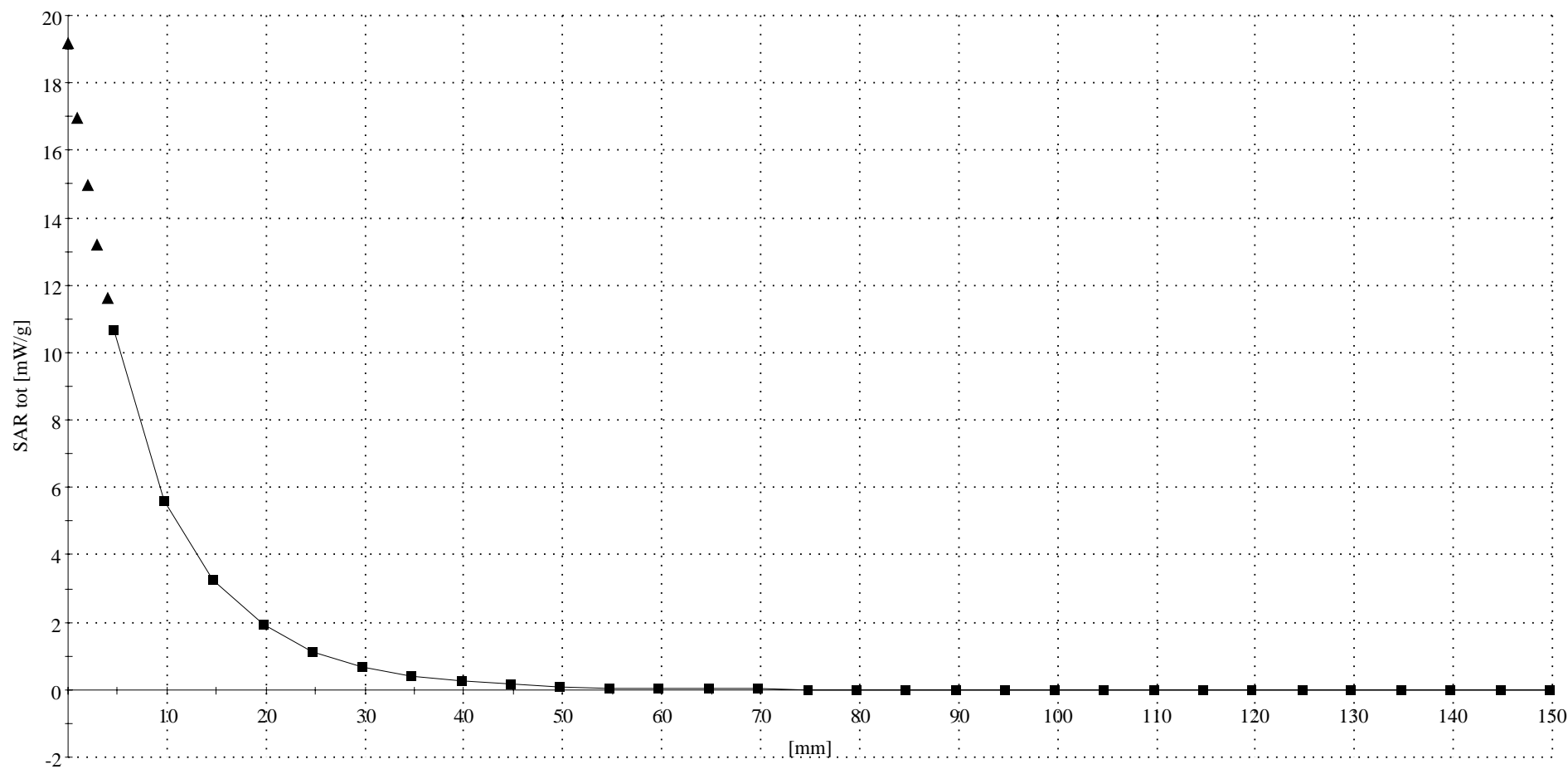

## Appendix 2

### SAR distribution plots for Phantom Head Adjacent Use

s/n: 1071

Ch# 661 / Pwr Step: 00 (OTA)

Type of Modulation: 1900 GSM

DEVICE POSITION: Cheek touch

Antenna Position: FIXED

Battery Model #: SNN5734A

R3 TP-1159 SAM GLYCOL Expanded (Rev. 2)-9Jan03 Phantom; Left Hand Section; Position: (90°,180°); Frequency: 1880 MHz

Probe: ET3DV6 - SN1520 - IEEE Head; ConvF(5.10,5.10,5.10); Crest factor: 8.0; 1880 MHz Head & Body:  $\sigma = 1.45$  mho/m  $\epsilon_r = 38.0$   $\rho = 1.00$  g/cm<sup>3</sup>

Cube 7x7x7: SAR (1g): 0.741 mW/g, SAR (10g): 0.432 mW/g, (Worst-case extrapolation)

Coarse: Dx = 15.0, Dy = 15.0, Dz = 15.0

Penetration depth: 10.8 (10.2, 11.5) [mm]

Powerdrift: -0.09 dB

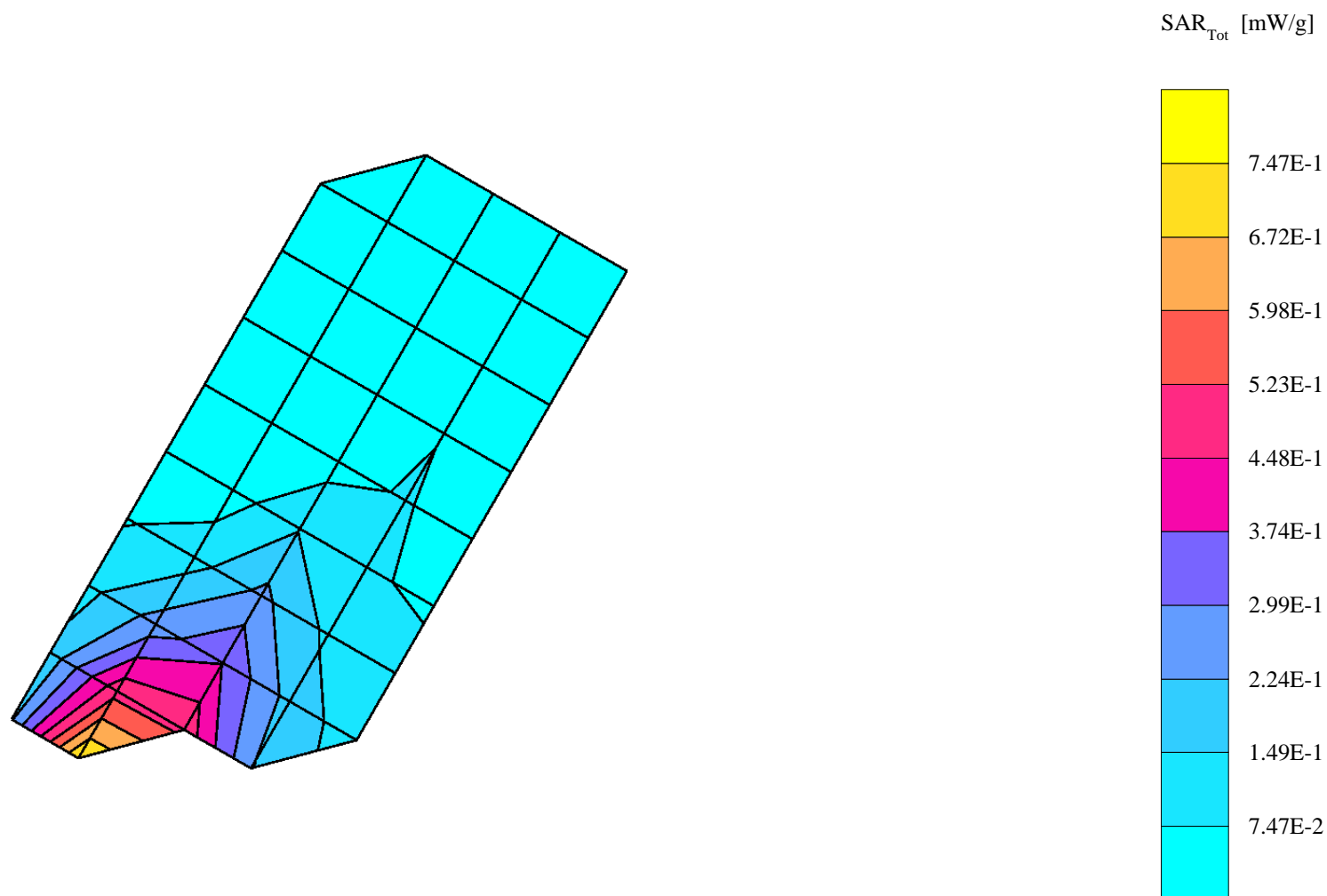

s/n: 1071

Ch# 661 / Pwr Step: 00 (OTA)

Type of Modulation: 1900 GSM

DEVICE POSITION: Cheek touch

CUBE

R3 TP-1159 SAM GLYCOL Expanded (Rev. 2)-9Jan03 Phantom; LH Front Tilt 20 Section; Position: (80°,180°); Frequency: 1880 MHz

Probe: ET3DV6 - SN1520 - IEEE Head; ConvF(5.10,5.10,5.10); Crest factor: 8.0; 1880 MHz Head & Body:  $\sigma = 1.45$  mho/m  $\epsilon_r = 38.0$   $\rho = 1.00$  g/cm<sup>3</sup>

Cube 7x7x7: SAR (1g): 0.741 mW/g, SAR (10g): 0.432 mW/g, (Worst-case extrapolation)

Cube 7x7x7: Dx = 5.0, Dy = 5.0, Dz = 5.0

Penetration depth: 10.8 (10.2, 11.5) [mm]

Antenna Position: FIXED

Battery Model #: SNN5734A

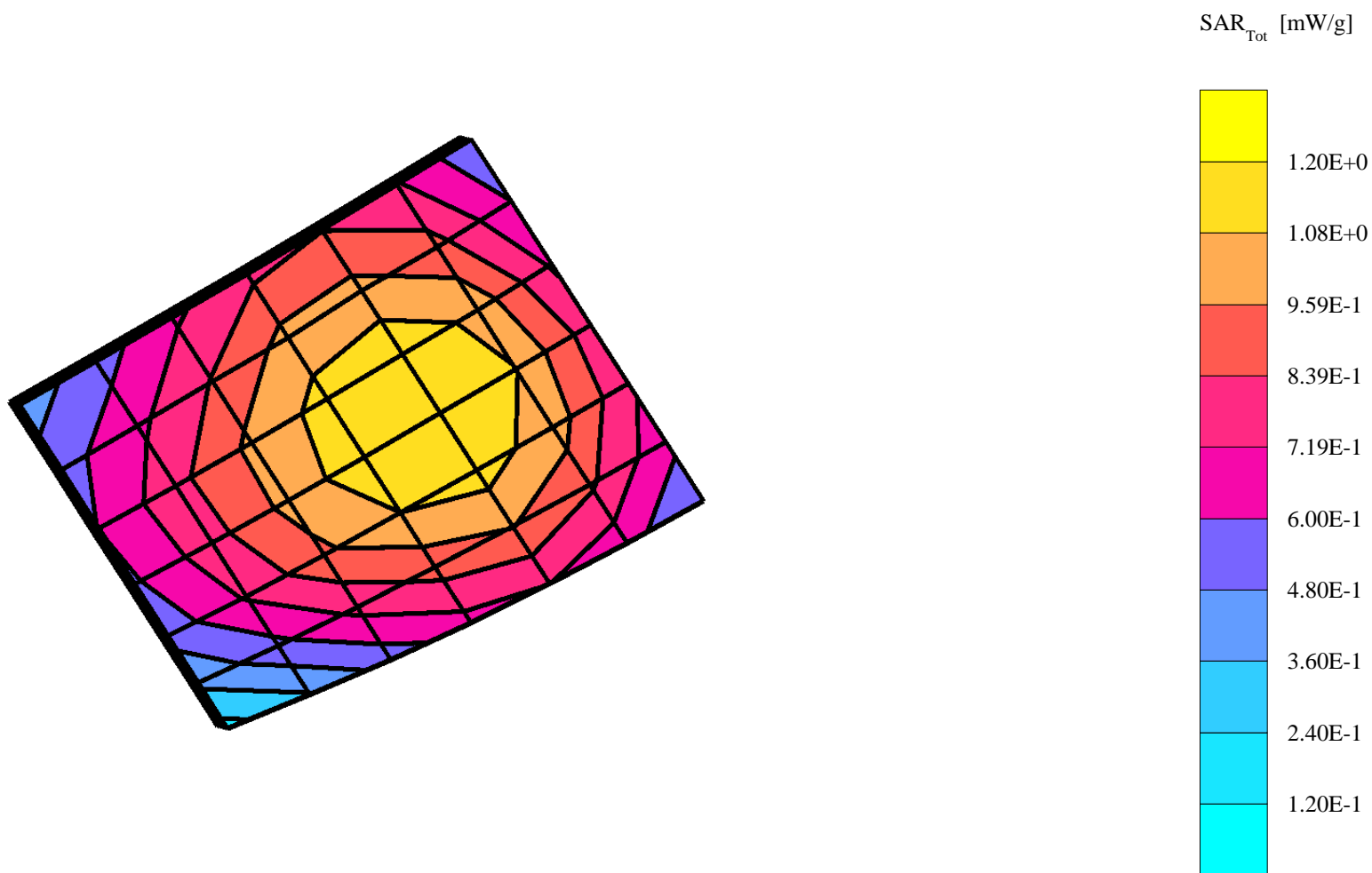

s/n: 1071

Ch# 661 / Pwr Step: 00 (OTA)

Type of Modulation: 1900 GSM

DEVICE POSITION: 15 deg TILT

R3 TP-1159 SAM GLYCOL Expanded (Rev. 2)-9Jan03 Phantom; Left Hand Section; Position: (90°,180°); Frequency: 1880 MHz

Probe: ET3DV6 - SN1520 - IEEE Head; ConvF(5.10,5.10,5.10); Crest factor: 8.0; 1880 MHz Head & Body:  $\sigma = 1.45$  mho/m  $\epsilon_r = 38.0$   $\rho = 1.00$  g/cm<sup>3</sup>

Cube 7x7x7: SAR (1g): 0.112 mW/g, SAR (10g): 0.0633 mW/g, (Worst-case extrapolation)

Coarse: Dx = 15.0, Dy = 15.0, Dz = 15.0

Penetration depth: 9.9 (9.8, 10.1) [mm]

Powerdrift: 0.05 dB

Antenna Position: FIXED

Battery Model #: SNN5734A

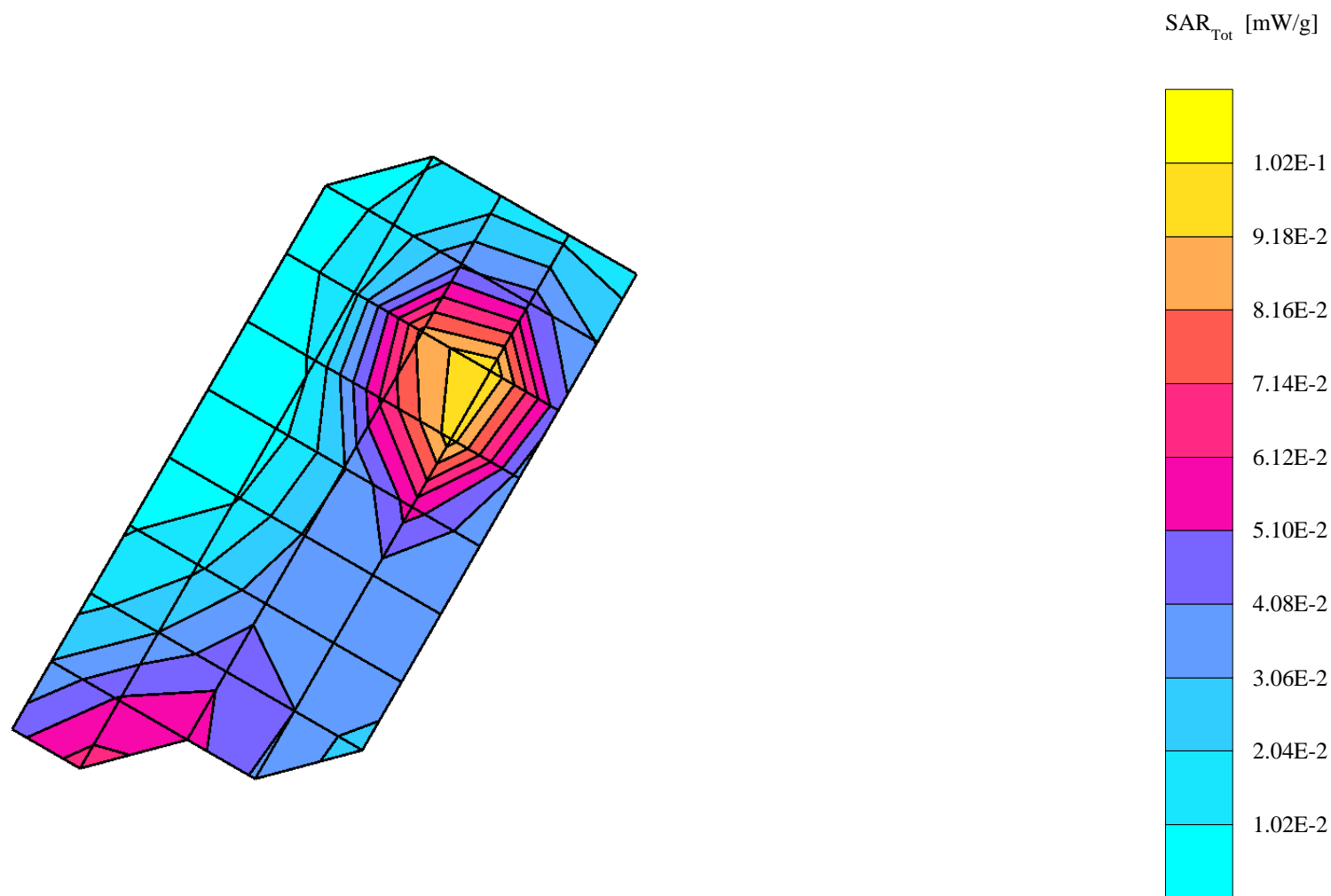

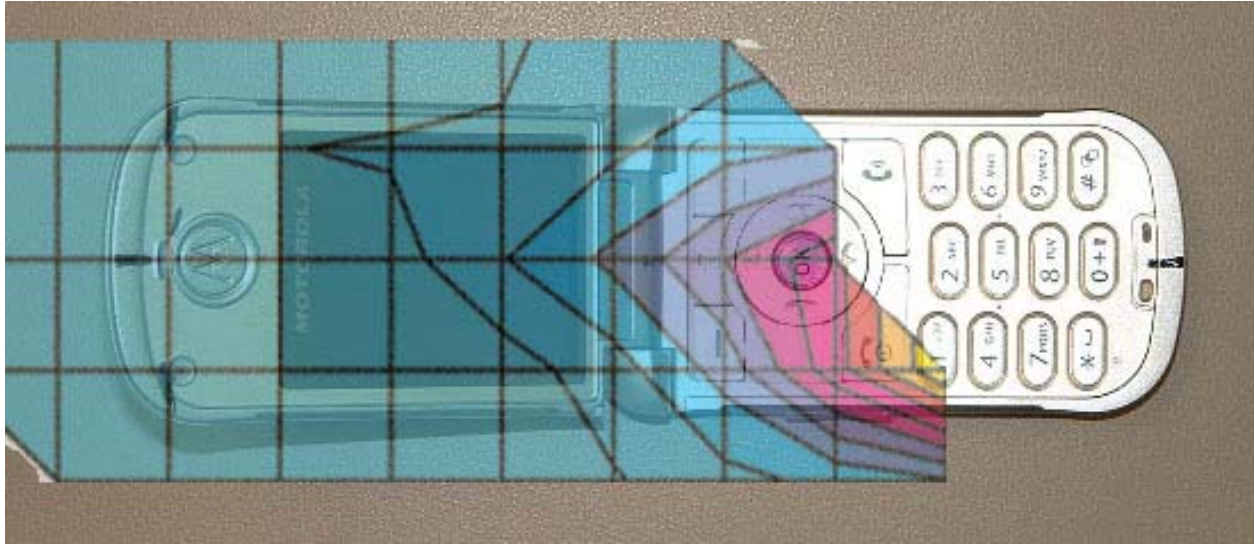

Figure 1. Typical 1900MHz Head Adjacent Contour Overlaid on Phone (Cheek Touch)

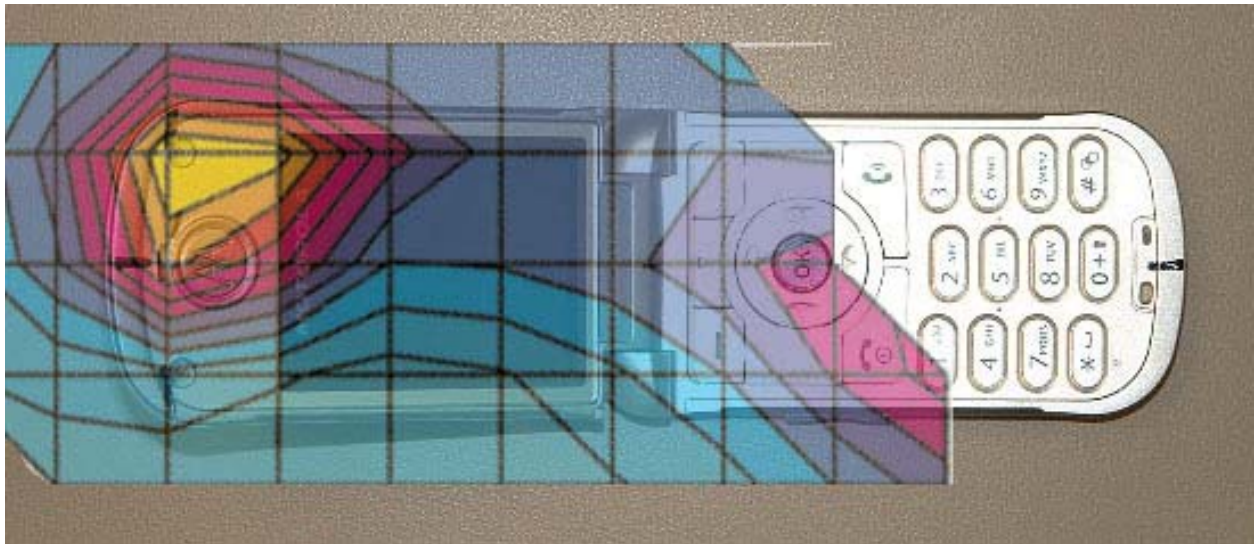

Figure 2. Typical 1900MHz Left Head Adjacent Contour Overlaid on Phone (15° Tilt)

### **Appendix 3**

#### **SAR distribution plots for Body Worn Configuration**

s/n: 1071

Ch# 661 / Pwr Step: 0 OTA

Type of Modulation: 1900 GSM

Accessory Model #: BACK OF PHONE 15MM FROM PHANTOM

R4 - Amy Twin Phantom Rev.4 (22Aug02) Phantom; section 2 Section; Position: (0°,0°); Frequency: 1880 MHz

Probe: ET3DV6 - SN1514 - FCC Body.2; ConvF(4.70,4.70,4.70); Crest factor: 8.0; 1880 MHz Head & Body:  $\sigma = 1.58$  mho/m  $\epsilon_r = 51.3$   $\rho = 1.00$  g/cm<sup>3</sup>

Cube 7x7x7: SAR (1g): 0.612 mW/g, SAR (10g): 0.345 mW/g, (Worst-case extrapolation)

Coarse: Dx = 15.0, Dy = 15.0, Dz = 10.0

Penetration depth: 9.3 (8.5, 10.7) [mm]

Powerdrift: -0.11 dB

Antenna Position: FIXED

Battery Model #: SNN5734A

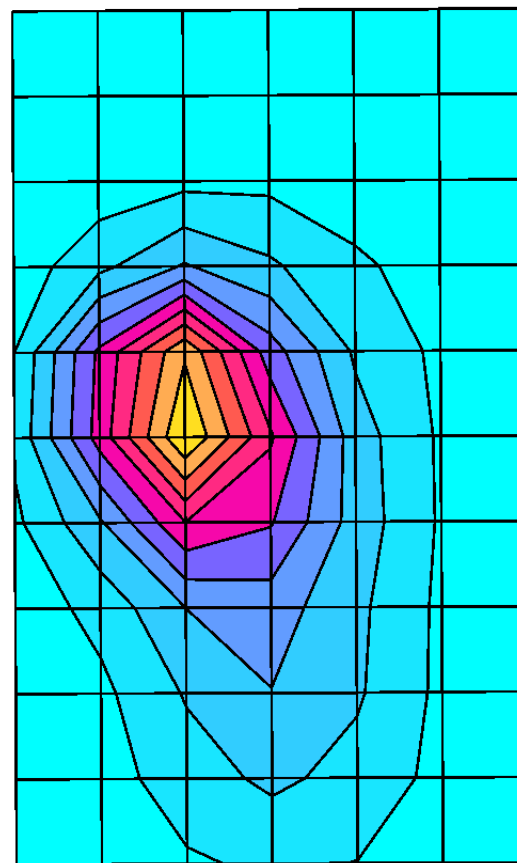
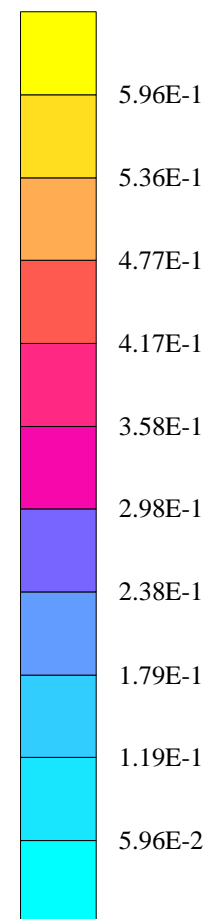
SAR<sub>Tot</sub> [mW/g]

s/n: 1071

Ch# 661 / Pwr Step: 0

Antenna Position: FIXED

Type of Modulation: 1900 GPRS

Battery Model #: SNN5734A

Accessory Model # = BACK OF PHONE 1"

R3 Amy Twin Phantom Rev.4 (22Aug02) Phantom; section 1 Section; Position: (0°,0°); Frequency: 1880 MHz

Probe: ET3DV6 - SN1520 - FCC Body; ConvF(4.80,4.80,4.80); Crest factor: 4.0; 1880 MHz Head & Body:  $\sigma = 1.59$  mho/m  $\epsilon_r = 51.5$   $\rho = 1.00$  g/cm<sup>3</sup>

Cube 7x7x7: SAR (1g): 0.389 mW/g, SAR (10g): 0.236 mW/g, (Worst-case extrapolation)

Coarse: Dx = 15.0, Dy = 15.0, Dz = 10.0

Penetration depth: 10.0 (9.1, 11.3) [mm]

Powerdrift: -0.10 dB

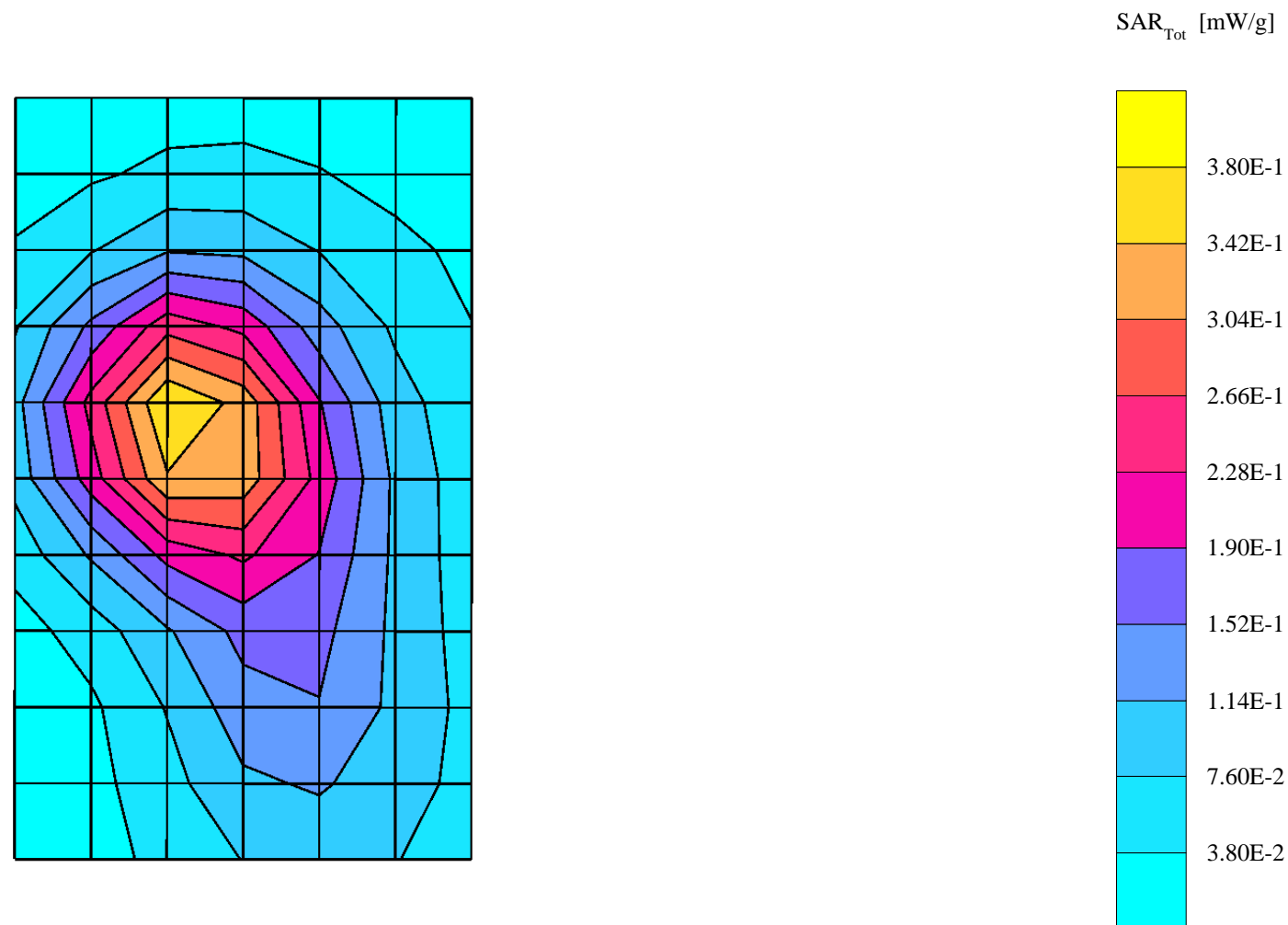

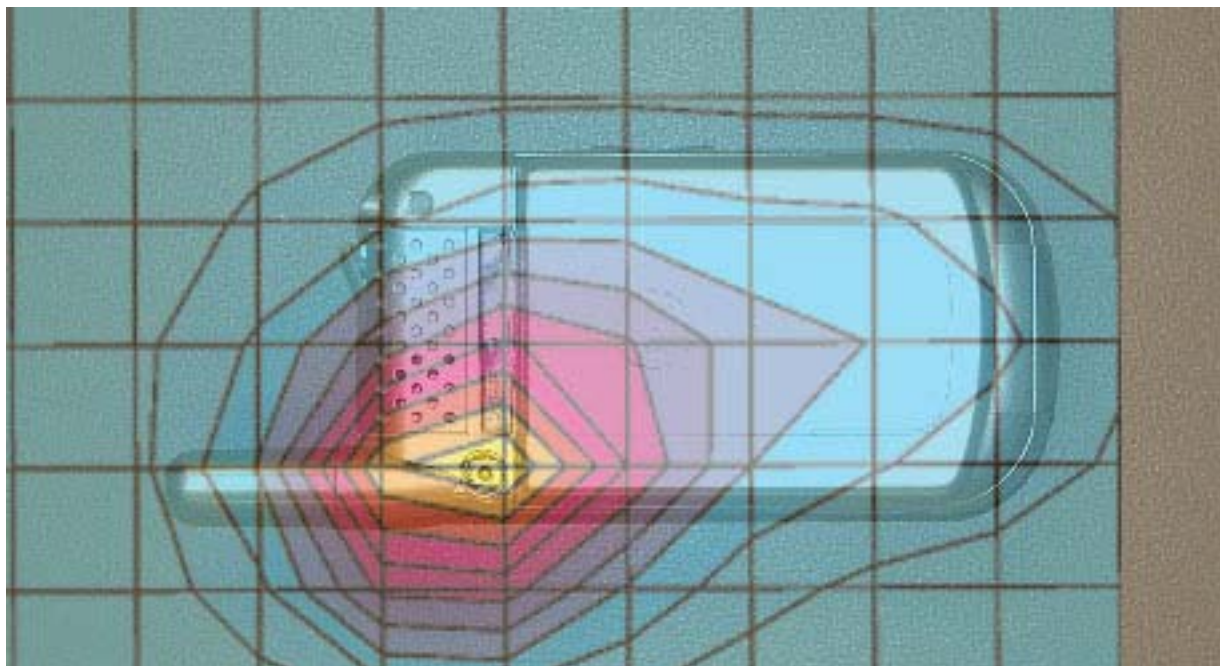

Figure 3. Typical 1900 MHz Body-Worn Contour Overlaid on Phone (GSM Mode)

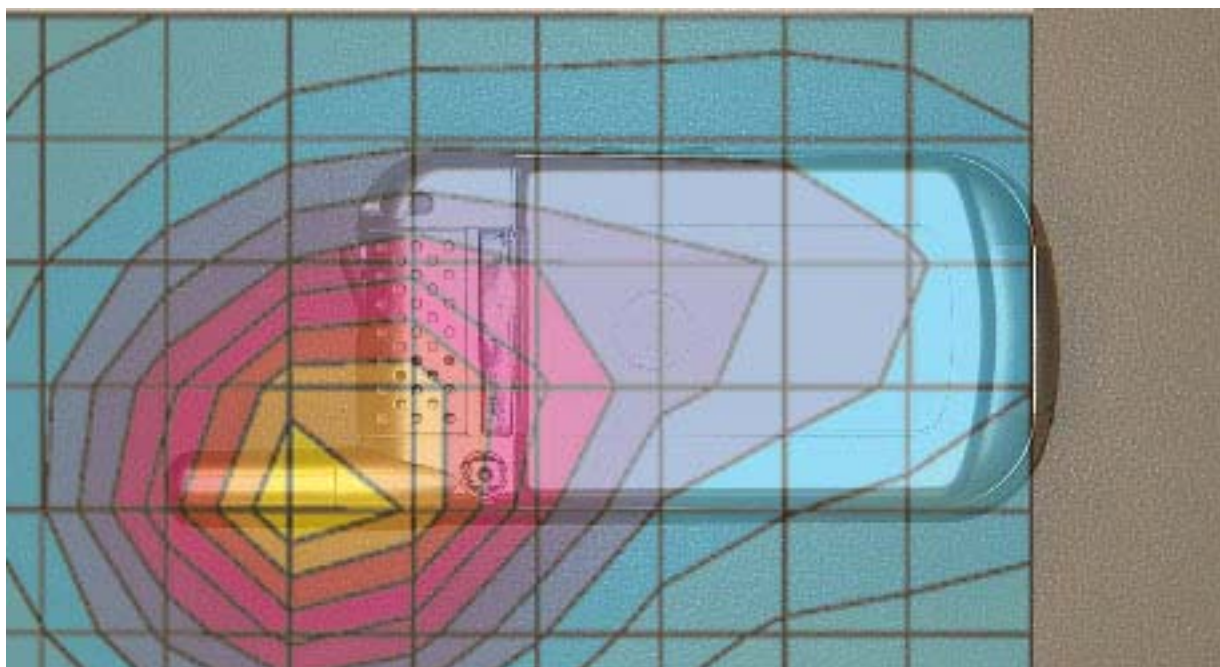

Figure 4. Typical 1900 MHz Body-Worn Contour Overlaid on Phone (GPRS Mode)

**Appendix 4**  
**Probe Calibration Certificate**

**Client**

**Motorola MRO**

**CALIBRATION CERTIFICATE**

Object(s)

ET3DV6 - SN 1514

Calibration procedure(s)

QA CAL-01 v2  
 Calibration procedure for dosimetric E-field probes

Calibration date:

July 31, 2003

Condition of the calibrated item

In Tolerance (according to the specific calibration document)

This calibration statement documents traceability of M&TE used in the calibration procedures and conformity of the procedures with the ISO/IEC 17025 international standard.

All calibrations have been conducted in the closed laboratory facility: environment temperature 22 +/- 2 degrees Celsius and humidity < 75%.

Calibration Equipment used (M&TE critical for calibration)

Model Type	ID #	Cal Date (Calibrated by, Certificate No.)	Scheduled Calibration
RF generator HP 8684C	US3642U01700	4-Aug-99 (SPEAG, in house check Aug-02)	In house check: Aug-05
Power sensor E4412A	MY41495277	2-Apr-03 (METAS, No 252-0250)	Apr-04
Power sensor HP 8481A	MY41092180	18-Sep-02 (Agilent, No. 20020918)	Sep-03
Power meter EPM E4419B	GB41293874	2-Apr-03 (METAS, No 252-0250)	Apr-04
Network Analyzer HP 8753E	US37390585	18-Oct-01 (Agilent, No. 24BR1033101)	In house check: Oct 03
Fluke Process Calibrator Type 702	SN: 6295803	3-Sep-01 (ELCAL, No.2360)	Sep-03

Calibrated by:

Name  
 Nico Vetterli

Function  
 Technician

Signature



Approved by:

Name  
 Katja Pekoic

Function  
 Laboratory Director

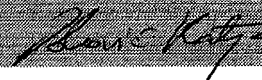

Date issued: July 31, 2003

This calibration certificate is issued as an intermediate solution until the accreditation process (based on ISO/IEC 17025 International Standard) for Calibration Laboratory of Schmid & Partner Engineering AG is completed.

# Probe ET3DV6

## SN:1514

Manufactured:	November 24, 1999
Last calibration:	July 25, 2002
Recalibrated:	July 31, 2003

**Calibrated for DASYS Systems**

(Note: non-compatible with DASYS2 system!)

## DASY - Parameters of Probe: ET3DV6 SN:1514

### Sensitivity in Free Space

NormX	<b>1.70</b> $\mu\text{V}/(\text{V}/\text{m})^2$
NormY	<b>1.86</b> $\mu\text{V}/(\text{V}/\text{m})^2$
NormZ	<b>1.79</b> $\mu\text{V}/(\text{V}/\text{m})^2$

### Diode Compression

DCP X	<b>93</b>	mV
DCP Y	<b>93</b>	mV
DCP Z	<b>93</b>	mV

### Sensitivity in Tissue Simulating Liquid

**Head**                      **900 MHz**                       $\epsilon_r = 41.5 \pm 5\%$                        $\sigma = 0.97 \pm 5\%$  mho/m  
Valid for f=800-1000 MHz with Head Tissue Simulating Liquid according to EN 50361, P1528-200X

ConvF X	<b>6.3</b> $\pm 9.5\%$ (k=2)	Boundary effect:
ConvF Y	<b>6.3</b> $\pm 9.5\%$ (k=2)	Alpha <b>0.58</b>
ConvF Z	<b>6.3</b> $\pm 9.5\%$ (k=2)	Depth <b>1.95</b>

**Head**                      **1800 MHz**                       $\epsilon_r = 40.0 \pm 5\%$                        $\sigma = 1.40 \pm 5\%$  mho/m  
Valid for f=1710-1910 MHz with Head Tissue Simulating Liquid according to EN 50361, P1528-200X

ConvF X	<b>5.1</b> $\pm 9.5\%$ (k=2)	Boundary effect:
ConvF Y	<b>5.1</b> $\pm 9.5\%$ (k=2)	Alpha <b>0.55</b>
ConvF Z	<b>5.1</b> $\pm 9.5\%$ (k=2)	Depth <b>2.48</b>

### Boundary Effect

**Head**                      **900 MHz**                      **Typical SAR gradient: 5 % per mm**

Probe Tip to Boundary		<b>1 mm</b>	<b>2 mm</b>
SAR <sub>be</sub> [%] Without Correction Algorithm		<b>9.7</b>	<b>5.1</b>
SAR <sub>be</sub> [%] With Correction Algorithm		<b>0.2</b>	<b>0.4</b>

**Head**                      **1800 MHz**                      **Typical SAR gradient: 10 % per mm**

Probe Tip to Boundary		<b>1 mm</b>	<b>2 mm</b>
SAR <sub>be</sub> [%] Without Correction Algorithm		<b>13.9</b>	<b>9.0</b>
SAR <sub>be</sub> [%] With Correction Algorithm		<b>0.1</b>	<b>0.0</b>

### Sensor Offset

Probe Tip to Sensor Center	<b>2.7</b>	mm
Optical Surface Detection	<b>0.8 <math>\pm</math> 0.2</b>	mm

### Receiving Pattern ( $\phi$ , $\theta = 0^\circ$ )

**f = 30 MHz, TEM cell ifi110**

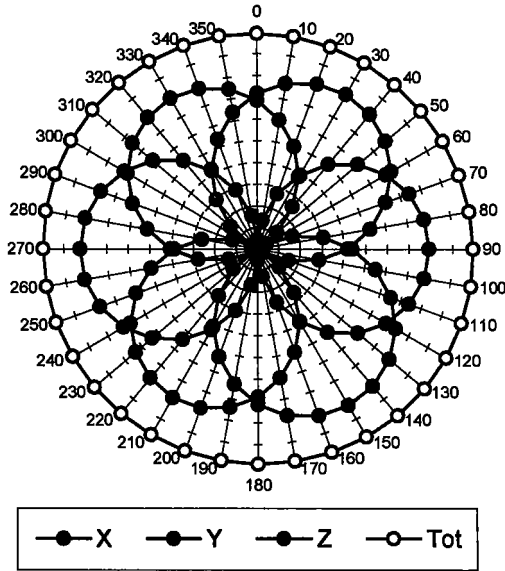

**f = 100 MHz, TEM cell ifi110**

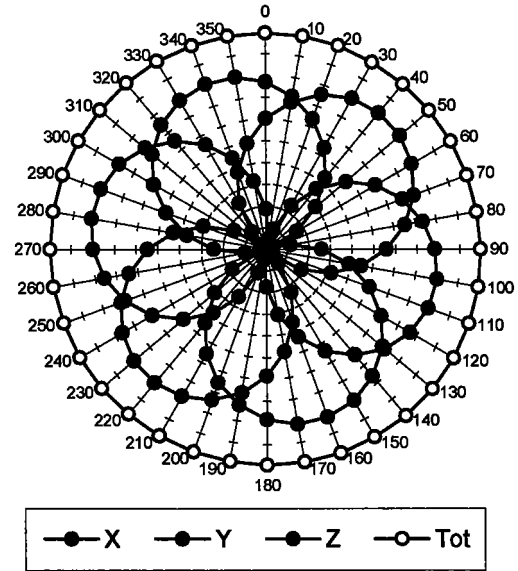

**f = 300 MHz, TEM cell ifi110**

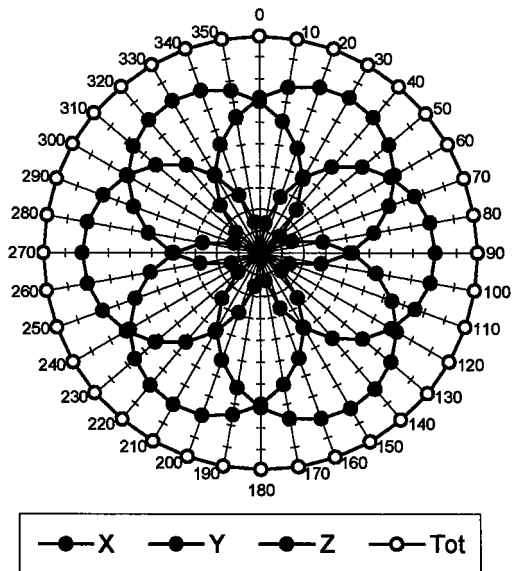

**f = 900 MHz, TEM cell ifi110**

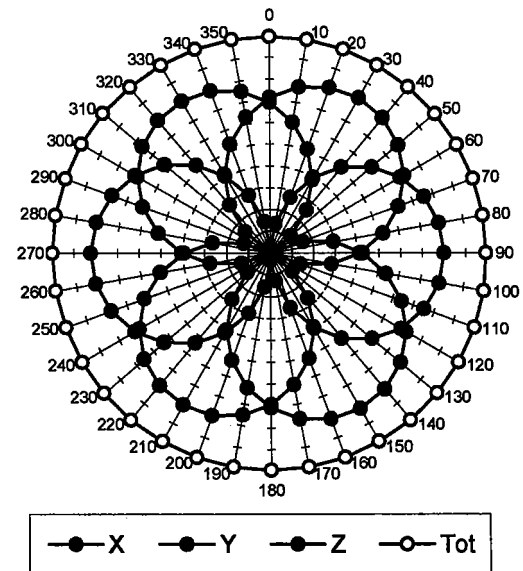

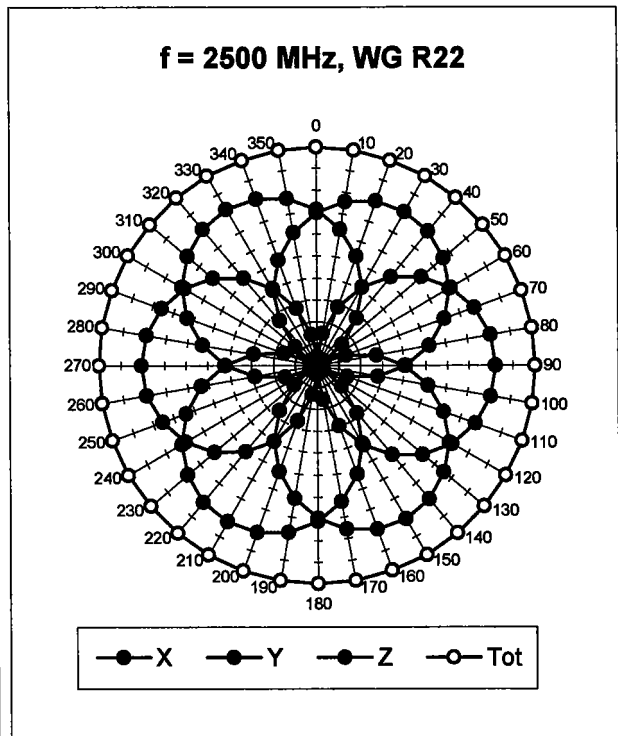
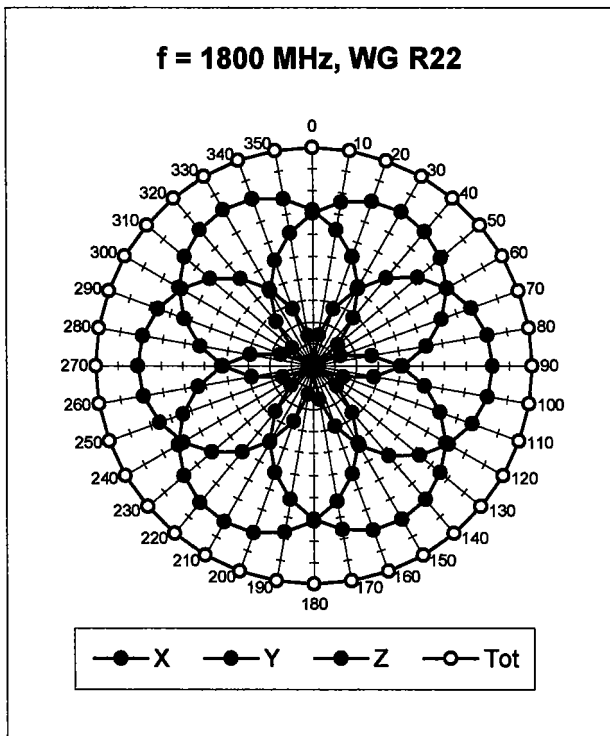

**Isotropy Error ( $\phi$ ),  $\theta = 0^\circ$**

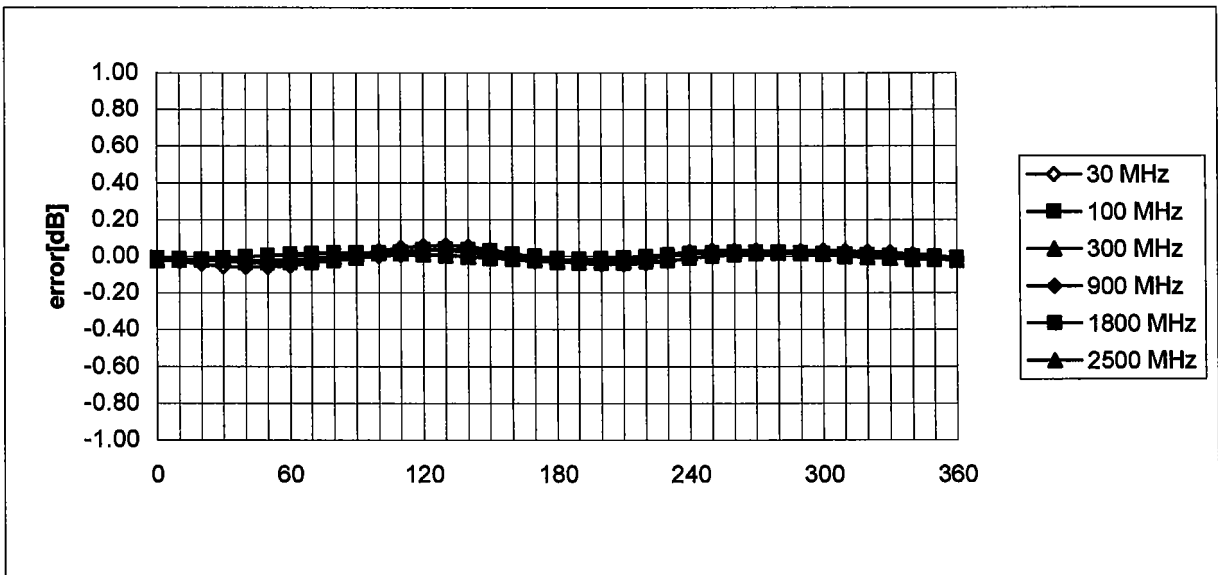

# Frequency Response of E-Field

( TEM-Cell:ifi110, Waveguide R22)

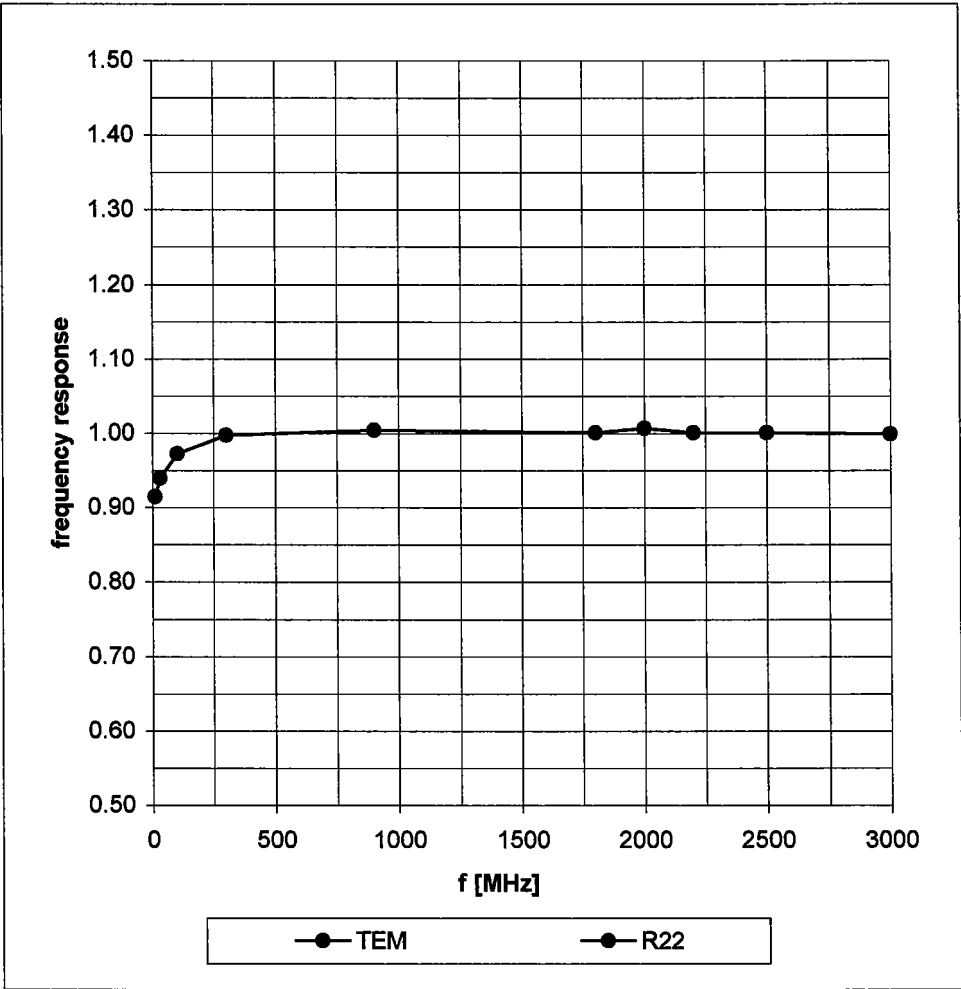

## Dynamic Range f(SAR<sub>brain</sub>) ( Waveguide R22 )

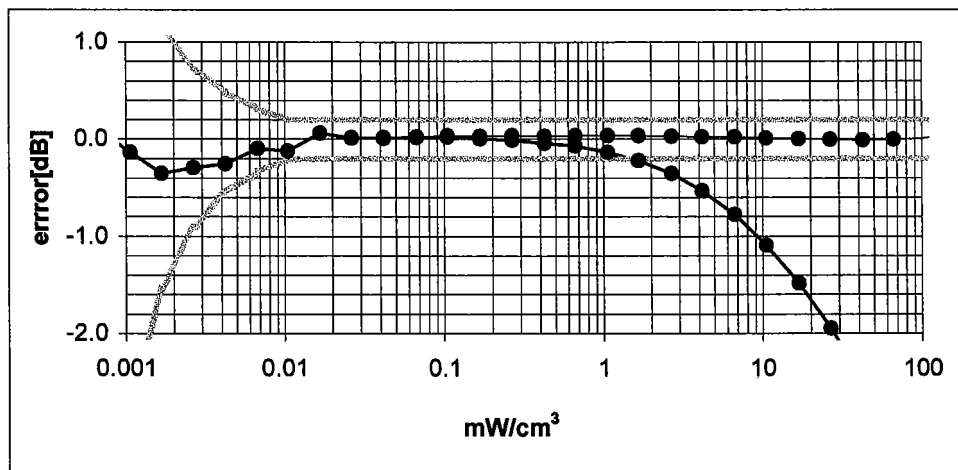
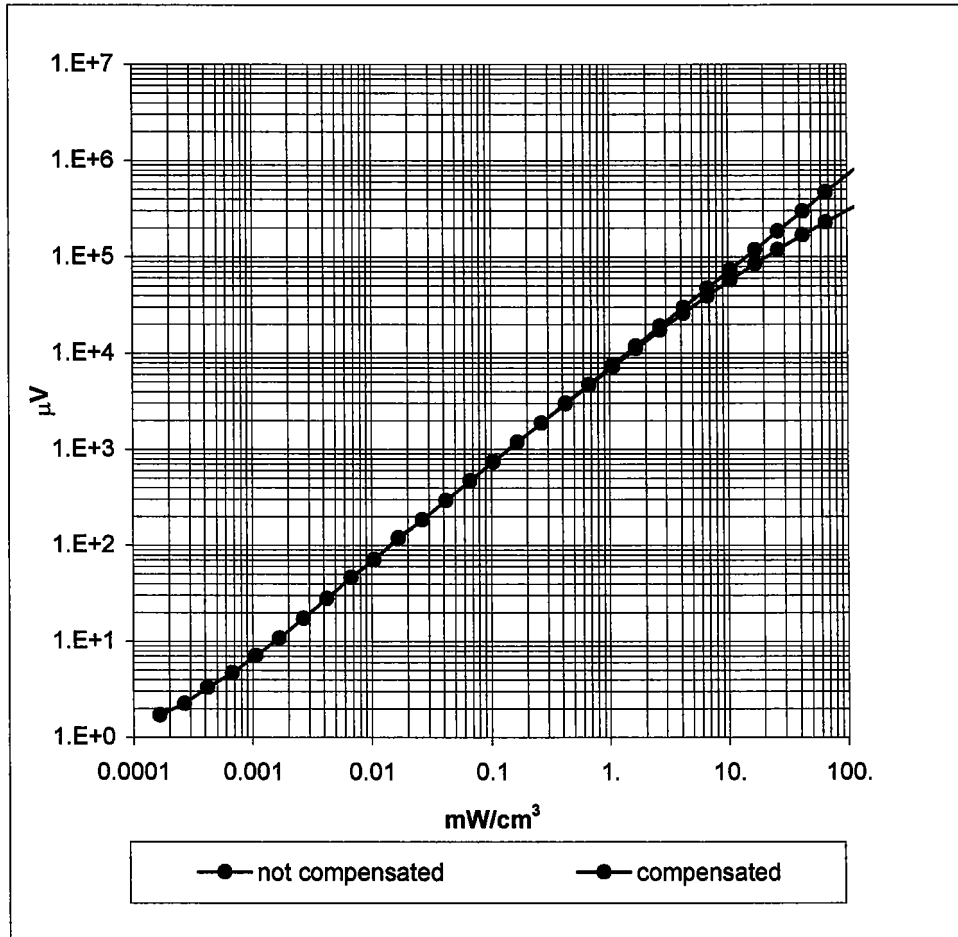

## Conversion Factor Assessment

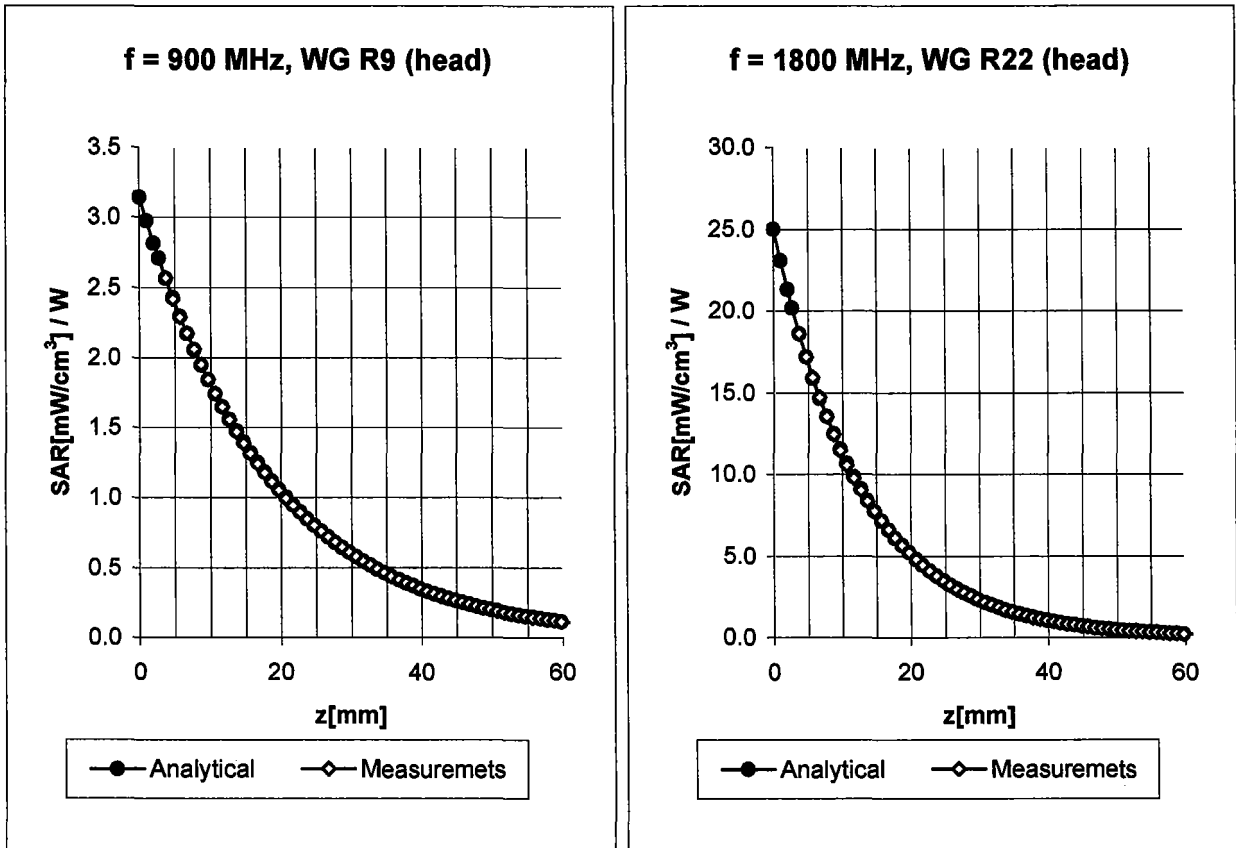

<b>Head</b>	<b>900 MHz</b>	$\epsilon_r = 41.5 \pm 5\%$	$\sigma = 0.97 \pm 5\%$ mho/m
<b>Valid for f=800-1000 MHz with Head Tissue Simulating Liquid according to EN 50361, P1528-200X</b>			
	ConvF X	<b>6.3</b> $\pm 9.5\%$ (k=2)	Boundary effect:
	ConvF Y	<b>6.3</b> $\pm 9.5\%$ (k=2)	Alpha <b>0.58</b>
	ConvF Z	<b>6.3</b> $\pm 9.5\%$ (k=2)	Depth <b>1.95</b>

<b>Head</b>	<b>1800 MHz</b>	$\epsilon_r = 40.0 \pm 5\%$	$\sigma = 1.40 \pm 5\%$ mho/m
<b>Valid for f=1710-1910 MHz with Head Tissue Simulating Liquid according to EN 50361, P1528-200X</b>			
	ConvF X	<b>5.1</b> $\pm 9.5\%$ (k=2)	Boundary effect:
	ConvF Y	<b>5.1</b> $\pm 9.5\%$ (k=2)	Alpha <b>0.55</b>
	ConvF Z	<b>5.1</b> $\pm 9.5\%$ (k=2)	Depth <b>2.48</b>

## Conversion Factor Assessment

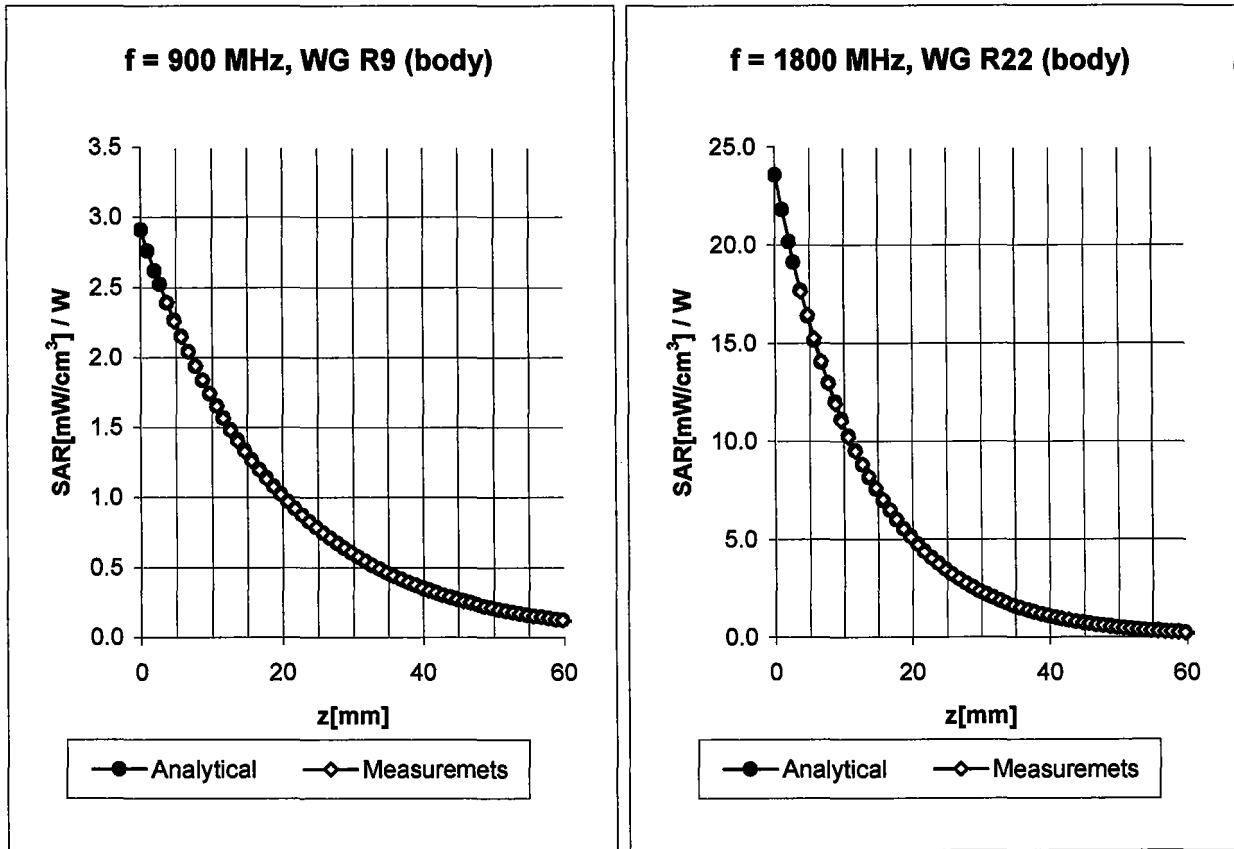

**Body                      900 MHz                       $\epsilon_r = 55.0 \pm 5\%$                        $\sigma = 1.05 \pm 5\%$  mho/m**

**Valid for f=800-1000 MHz with Head Tissue Simulating Liquid according to OET 65 Suppl. C**

ConvF X	<b>6.1</b> $\pm 9.5\%$ (k=2)	Boundary effect:
ConvF Y	<b>6.1</b> $\pm 9.5\%$ (k=2)	Alpha <b>0.51</b>
ConvF Z	<b>6.1</b> $\pm 9.5\%$ (k=2)	Depth <b>2.18</b>

**Body                      1800 MHz                       $\epsilon_r = 53.3 \pm 5\%$                        $\sigma = 1.52 \pm 5\%$  mho/m**

**Valid for f=1710-1910 MHz with Head Tissue Simulating Liquid according to OET 65 Suppl. C**

ConvF X	<b>4.7</b> $\pm 9.5\%$ (k=2)	Boundary effect:
ConvF Y	<b>4.7</b> $\pm 9.5\%$ (k=2)	Alpha <b>0.57</b>
ConvF Z	<b>4.7</b> $\pm 9.5\%$ (k=2)	Depth <b>2.85</b>

## Conversion Factor Assessment

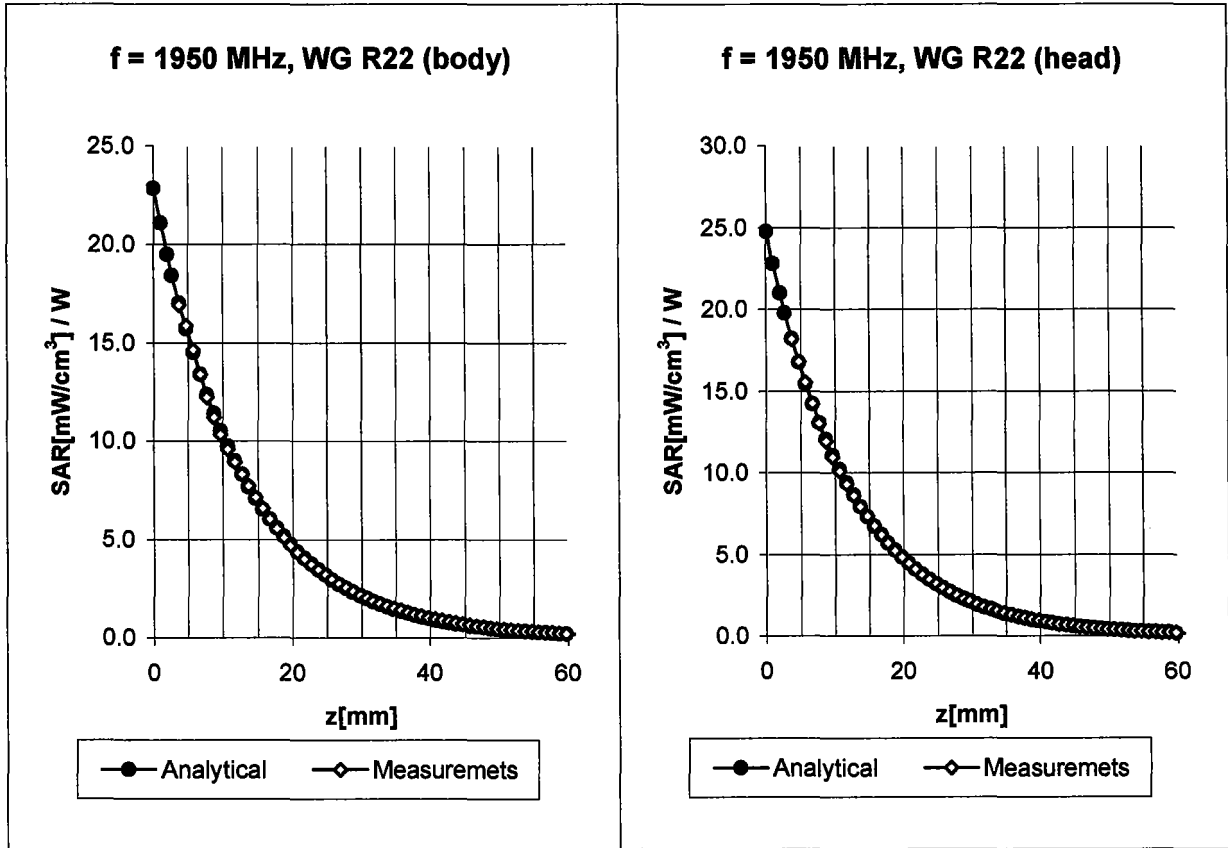

<b>Body</b>	<b>1950 MHz</b>	$\epsilon_r = 53.3 \pm 5\%$	$\sigma = 1.52 \pm 5\% \text{ mho/m}$
	ConvF X	<b>4.5</b> $\pm 9.5\%$ (k=2)	Boundary effect:
	ConvF Y	<b>4.5</b> $\pm 9.5\%$ (k=2)	Alpha <b>0.80</b>
	ConvF Z	<b>4.5</b> $\pm 9.5\%$ (k=2)	Depth <b>2.23</b>

<b>Head</b>	<b>1950 MHz</b>	$\epsilon_r = 40.0 \pm 5\%$	$\sigma = 1.40 \pm 5\% \text{ mho/m}$
	ConvF X	<b>5.0</b> $\pm 8.9\%$ (k=2)	Boundary effect:
	ConvF Y	<b>5.0</b> $\pm 8.9\%$ (k=2)	Alpha <b>0.60</b>
	ConvF Z	<b>5.0</b> $\pm 8.9\%$ (k=2)	Depth <b>2.44</b>

## Conversion Factor Assessment

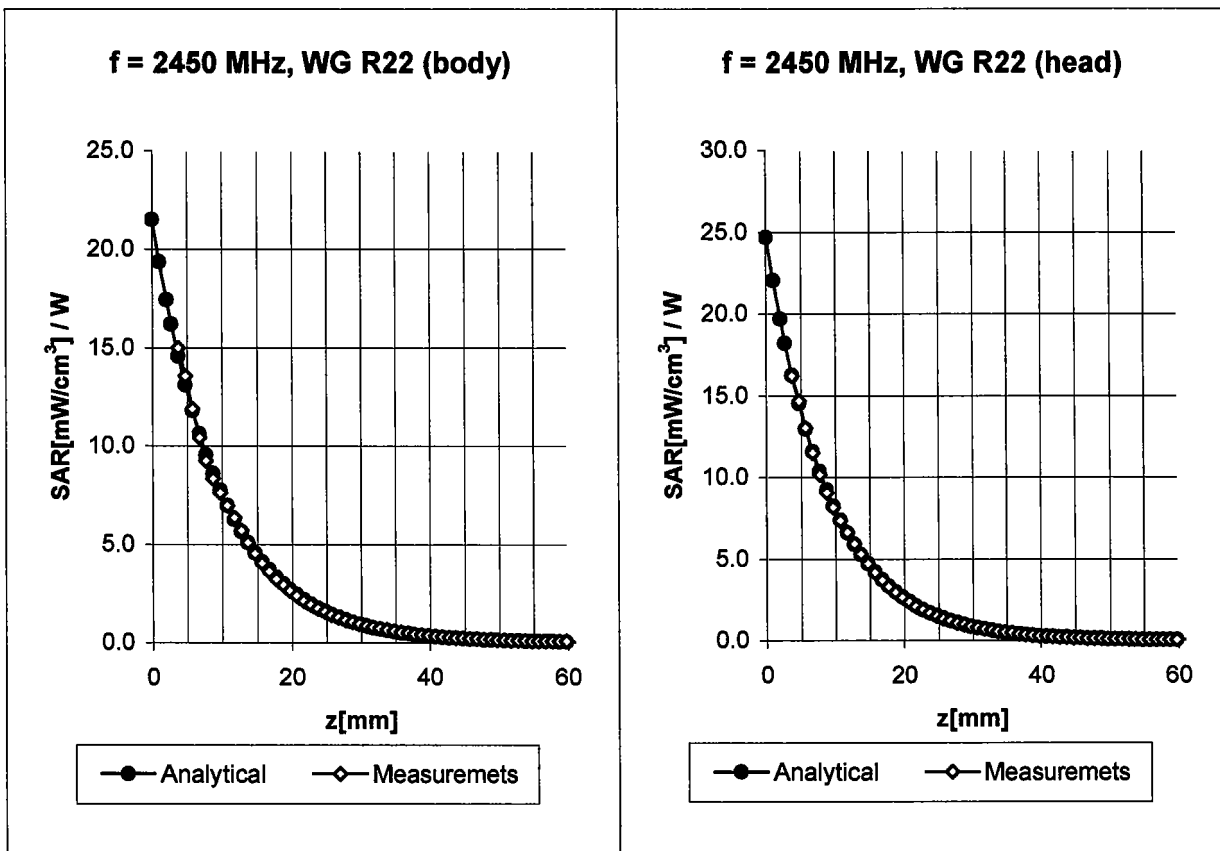

**Body                      2450 MHz                       $\epsilon_r = 52.7 \pm 5\%$                        $\sigma = 1.95 \pm 5\%$  mho/m**

**Valid for f=2400-2500 MHz with Body Tissue Simulating Liquid according to OET 65 Suppl. C**

ConvF X	<b>4.4</b> $\pm$ 8.9% (k=2)	Boundary effect:
ConvF Y	<b>4.4</b> $\pm$ 8.9% (k=2)	Alpha <b>1.55</b>
ConvF Z	<b>4.4</b> $\pm$ 8.9% (k=2)	Depth <b>1.45</b>

**Head                      2450 MHz                       $\epsilon_r = 39.2 \pm 5\%$                        $\sigma = 1.80 \pm 5\%$  mho/m**

**Valid for f=2400-2500 MHz with Head Tissue Simulating Liquid according to EN 50361, P1528-200X**

ConvF X	<b>4.7</b> $\pm$ 8.9% (k=2)	Boundary effect:
ConvF Y	<b>4.7</b> $\pm$ 8.9% (k=2)	Alpha <b>1.24</b>
ConvF Z	<b>4.7</b> $\pm$ 8.9% (k=2)	Depth <b>1.67</b>

# Deviation from Isotropy in HSL

Error ( $\theta\phi$ ),  $f = 900$  MHz

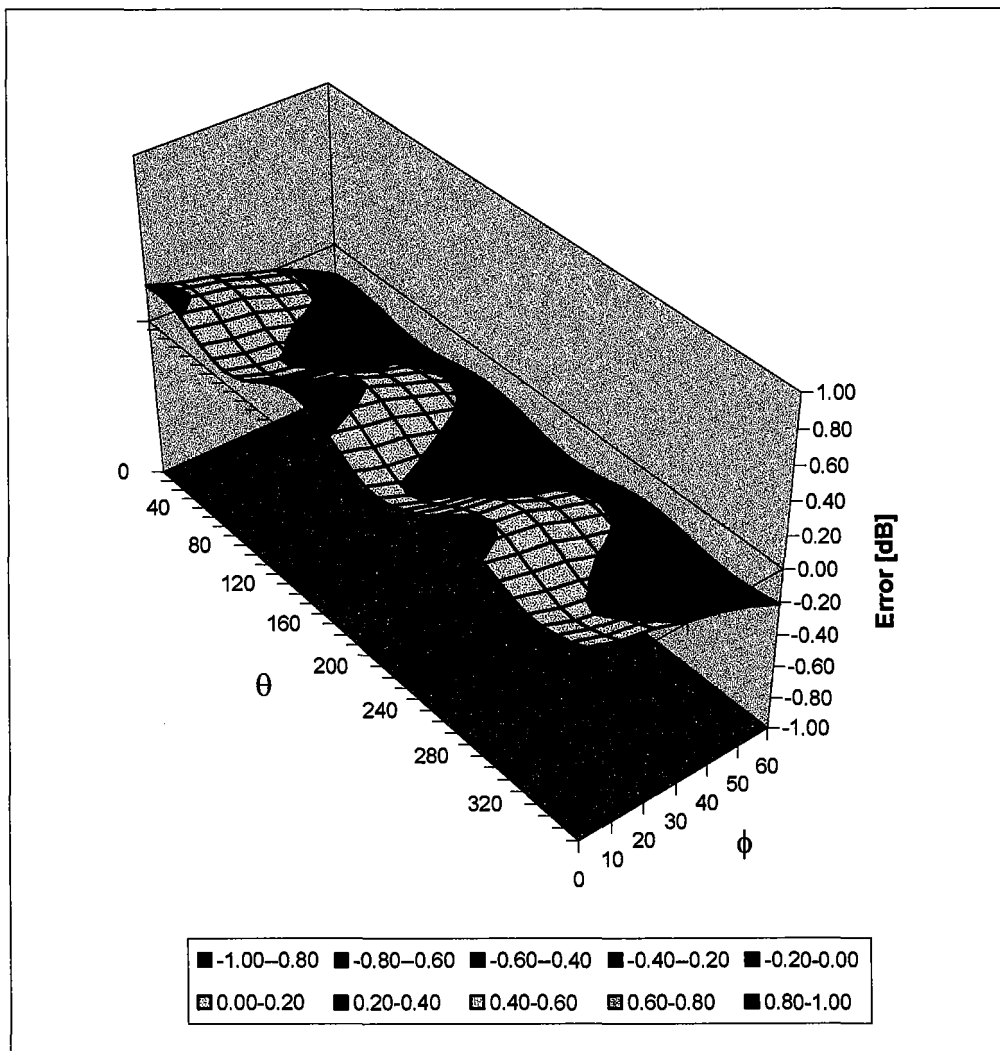

**Client**      **Motorola Korea (MRO)**

**CALIBRATION CERTIFICATE**

**Object(s)**      **ET3DV6 - SN 1520**

**Calibration procedure(s)**      **QA CAL-01 v2  
 Calibration procedure for dosimetric E-field probes**

**Calibration date:**      **June 9, 2003**



**Condition of the calibrated item**      **In Tolerance (according to the specific calibration document)**

This calibration statement documents traceability of M&TE used in the calibration procedures and conformity of the procedures with the ISO/IEC 17025 international standard.

All calibrations have been conducted in the closed laboratory facility: environment temperature 22 +/- 2 degrees Celsius and humidity < 75%.

**Calibration Equipment used (M&TE critical for calibration)**

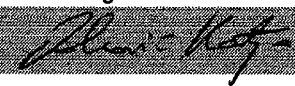
Model Type	ID #	Cal Date (Calibrated by, Certificate No.)	Scheduled Calibration
RF generator HP 8684C	US3642U01700	4-Aug-99 (SPEAG, in house check Aug-02)	In house check: Aug-05
Power sensor E4412A	MY41495277	2-Apr-03 (METAS, No 252-0250)	Apr-04
Power sensor HP 8481A	MY41092180	18-Sep-02 (Agilent, No. 20020918)	Sep-03
Power meter EPM E4419B	GB41293874	2-Apr-03 (METAS, No 252-0250)	Apr-04
Network Analyzer HP 8753E	US37390585	18-Oct-01 (Agilent, No. 24BR1033101)	In house check: Oct 03
Fluke Process Calibrator Type 702	SN: 6295803	3-Sep-01 (ELCAL, No.2360)	Sep-03

	Name	Function	Signature
Calibrated by:	Katja Pakevic	Laboratory Director	
Approved by:	Fin Bommert	R&D Director	

Date issued: June 9, 2003

This calibration certificate is issued as an intermediate solution until the accreditation process (based on ISO/IEC 17025 International Standard) for Calibration Laboratory of Schmid & Partner Engineering AG is completed.

# Probe ET3DV6

## SN:1520

Manufactured:	February 1, 2000
Last calibration:	May 8, 2002
Recalibrated:	June 9, 2003

**Calibrated for DASYS Systems**

(Note: non-compatible with DASYS2 system!)

## DASY - Parameters of Probe: ET3DV6 SN:1520

### Sensitivity in Free Space

NormX	<b>1.87</b> $\mu\text{V}/(\text{V}/\text{m})^2$
NormY	<b>1.67</b> $\mu\text{V}/(\text{V}/\text{m})^2$
NormZ	<b>1.85</b> $\mu\text{V}/(\text{V}/\text{m})^2$

### Diode Compression

DCP X	<b>95</b>	mV
DCP Y	<b>95</b>	mV
DCP Z	<b>95</b>	mV

### Sensitivity in Tissue Simulating Liquid

Head                      900 MHz                       $\epsilon_r = 41.5 \pm 5\%$                        $\sigma = 0.97 \pm 5\%$  mho/m

Valid for f=800-1000 MHz with Head Tissue Simulating Liquid according to EN 50361, P1528-200X

ConvF X	<b>6.5</b> $\pm 9.5\%$ (k=2)	Boundary effect:
ConvF Y	<b>6.5</b> $\pm 9.5\%$ (k=2)	Alpha <b>0.42</b>
ConvF Z	<b>6.5</b> $\pm 9.5\%$ (k=2)	Depth <b>2.27</b>

Head                      1800 MHz                       $\epsilon_r = 40.0 \pm 5\%$                        $\sigma = 1.40 \pm 5\%$  mho/m

Valid for f=1710-1910 MHz with Head Tissue Simulating Liquid according to EN 50361, P1528-200X

ConvF X	<b>5.1</b> $\pm 9.5\%$ (k=2)	Boundary effect:
ConvF Y	<b>5.1</b> $\pm 9.5\%$ (k=2)	Alpha <b>0.50</b>
ConvF Z	<b>5.1</b> $\pm 9.5\%$ (k=2)	Depth <b>2.63</b>

### Boundary Effect

Head                      900 MHz                      Typical SAR gradient: 5 % per mm

Probe Tip to Boundary		<b>1 mm</b>	<b>2 mm</b>
SAR <sub>be</sub> [%]	Without Correction Algorithm	9.3	5.2
SAR <sub>be</sub> [%]	With Correction Algorithm	0.3	0.4

Head                      1800 MHz                      Typical SAR gradient: 10 % per mm

Probe Tip to Boundary		<b>1 mm</b>	<b>2 mm</b>
SAR <sub>be</sub> [%]	Without Correction Algorithm	13.6	9.3
SAR <sub>be</sub> [%]	With Correction Algorithm	0.2	0.2

### Sensor Offset

Probe Tip to Sensor Center	<b>2.7</b>	mm
Optical Surface Detection	<b>1.7 <math>\pm</math> 0.2</b>	mm

### Receiving Pattern ( $\phi$ ), $\theta = 0^\circ$

f = 30 MHz, TEM cell ifi110

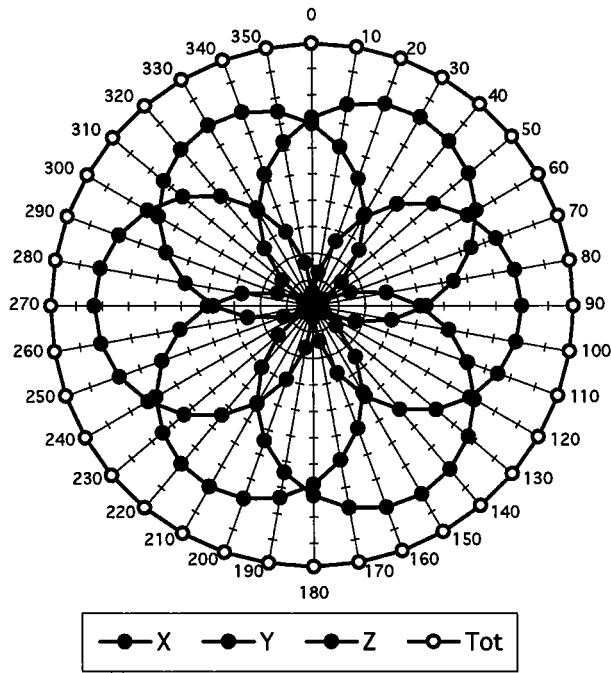

f = 100 MHz, TEM cell ifi110

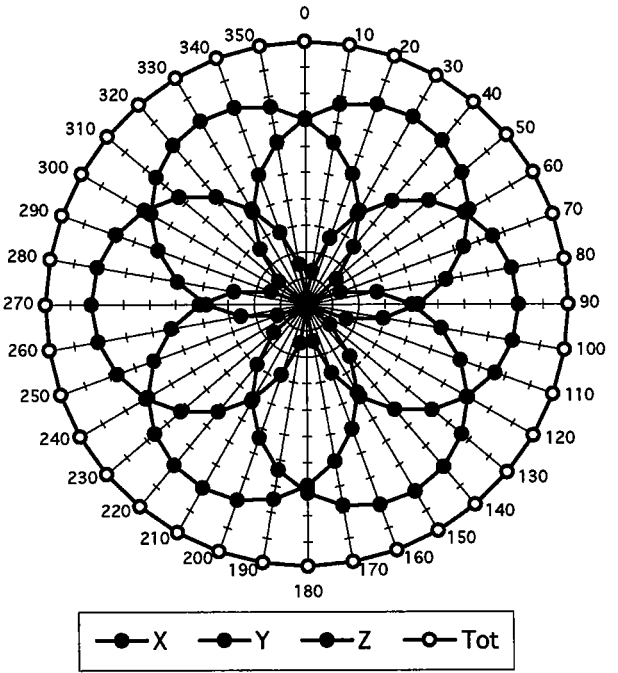

f = 300 MHz, TEM cell ifi110

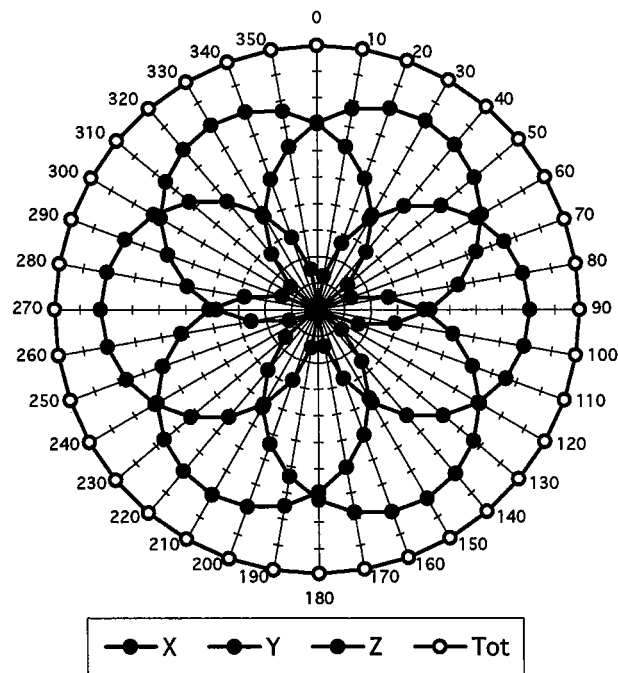

f = 900 MHz, TEM cell ifi110

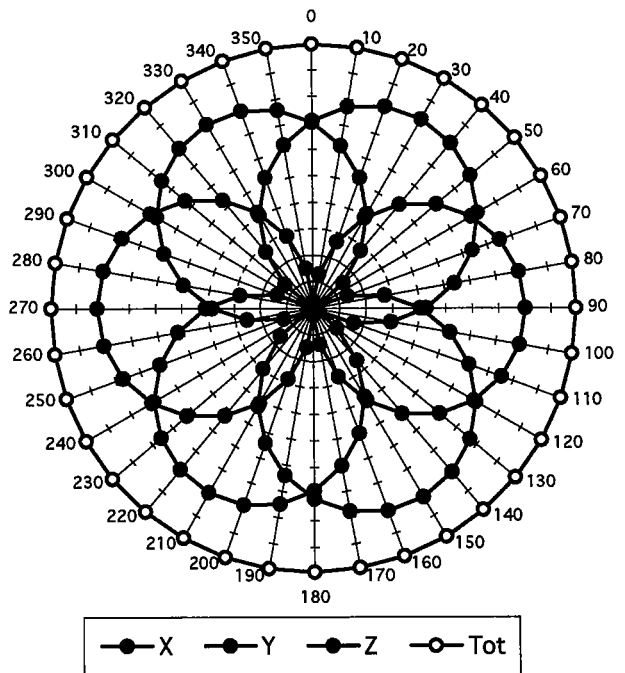

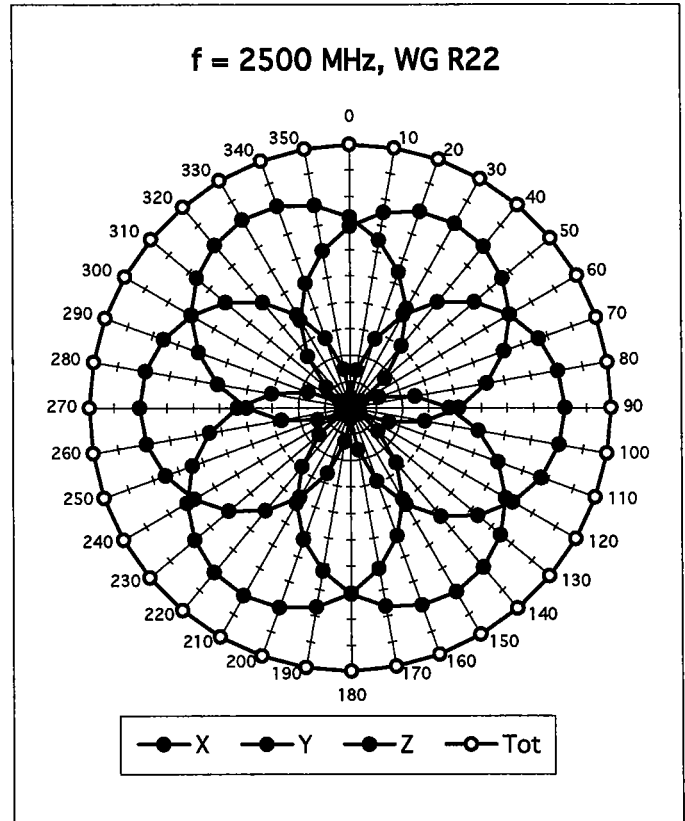
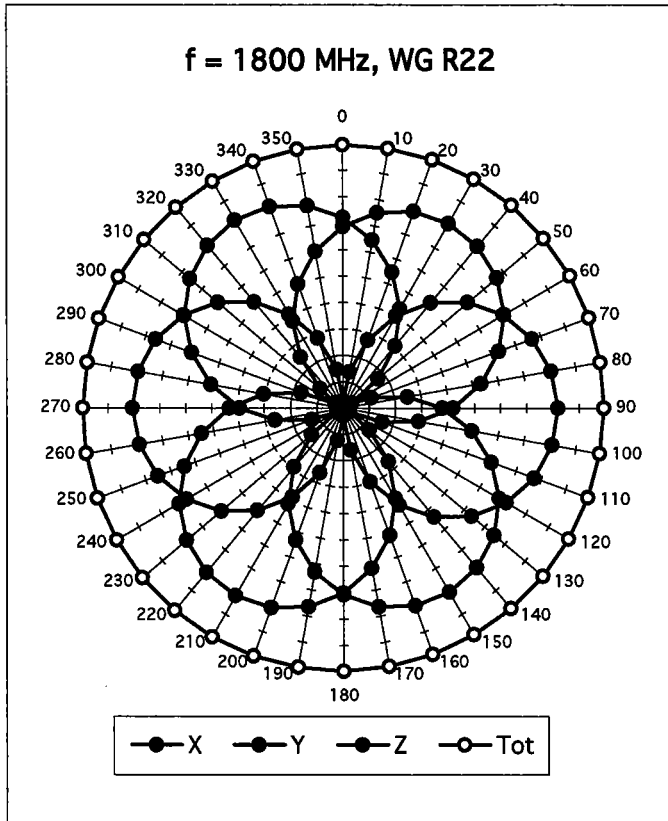

### Isotropy Error ( $\phi$ ), $\theta = 0^\circ$

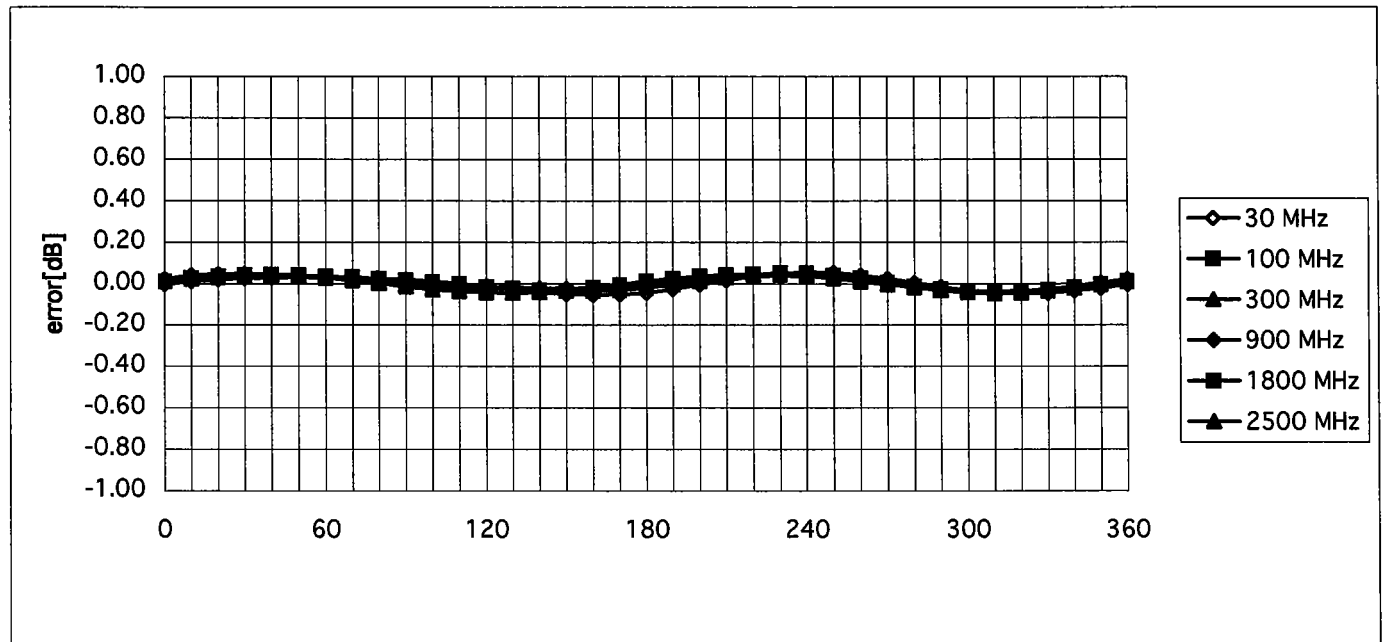

# Frequency Response of E-Field

( TEM-Cell:if1110, Waveguide R22)

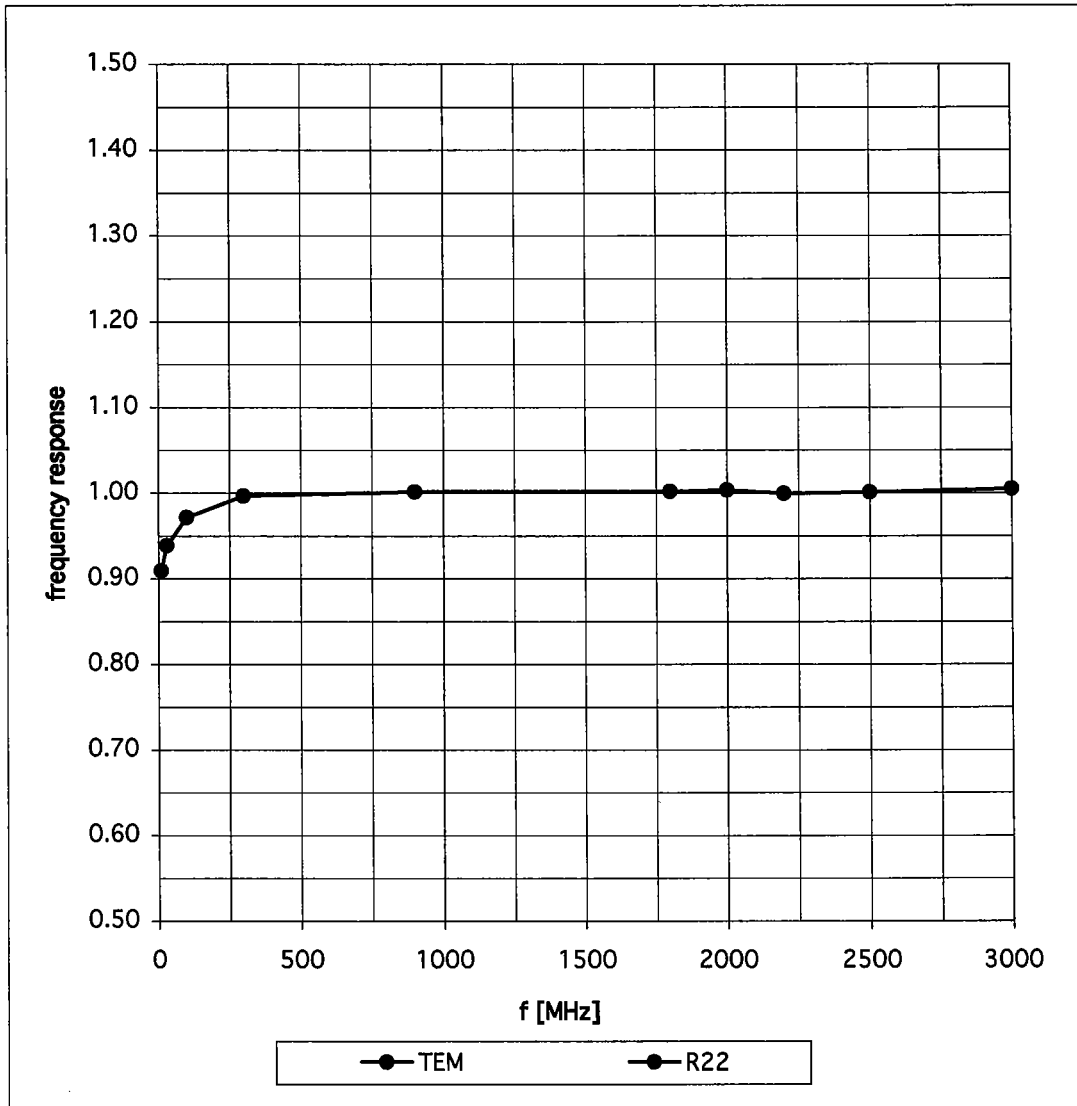

# Dynamic Range f(SAR<sub>brain</sub>)

( Waveguide R22 )

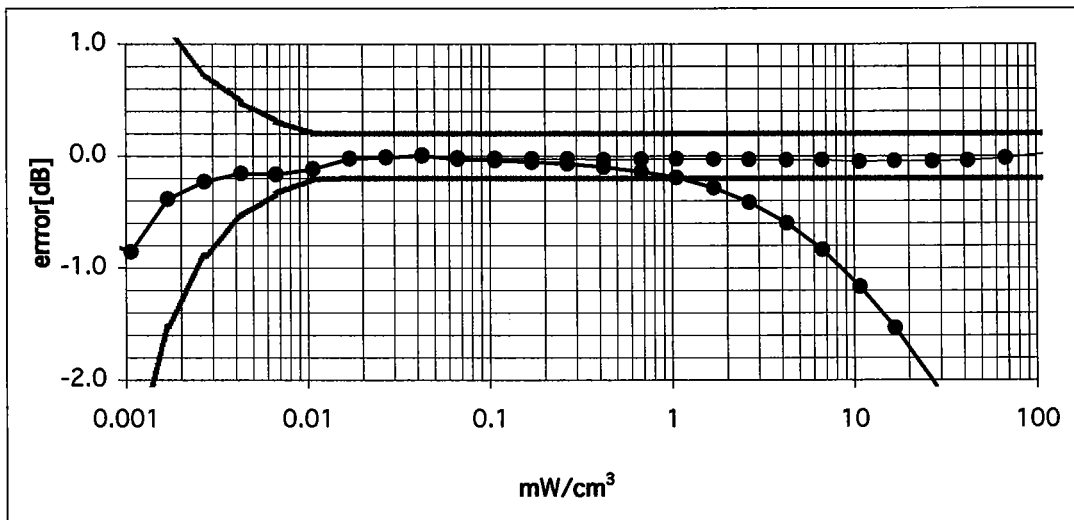
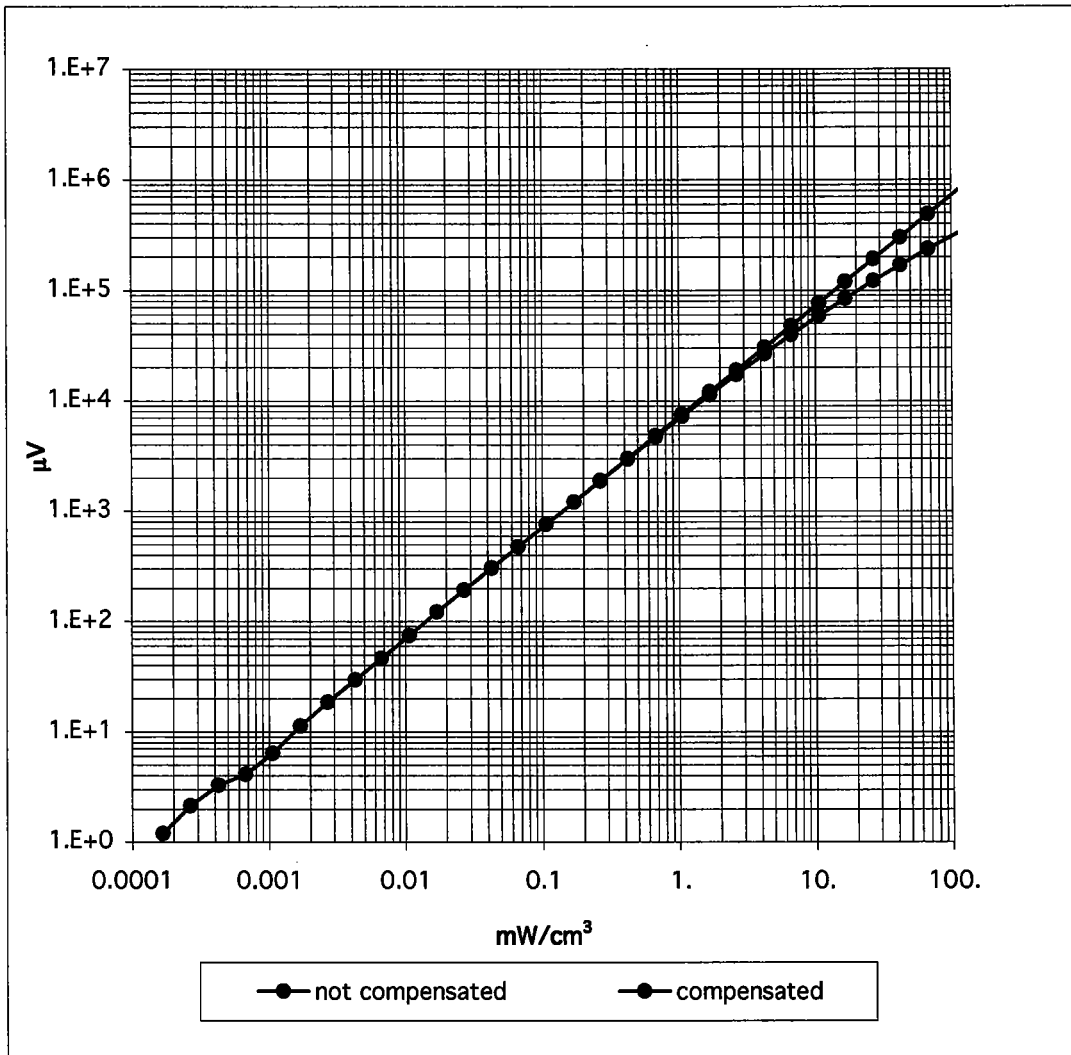

# Conversion Factor Assessment

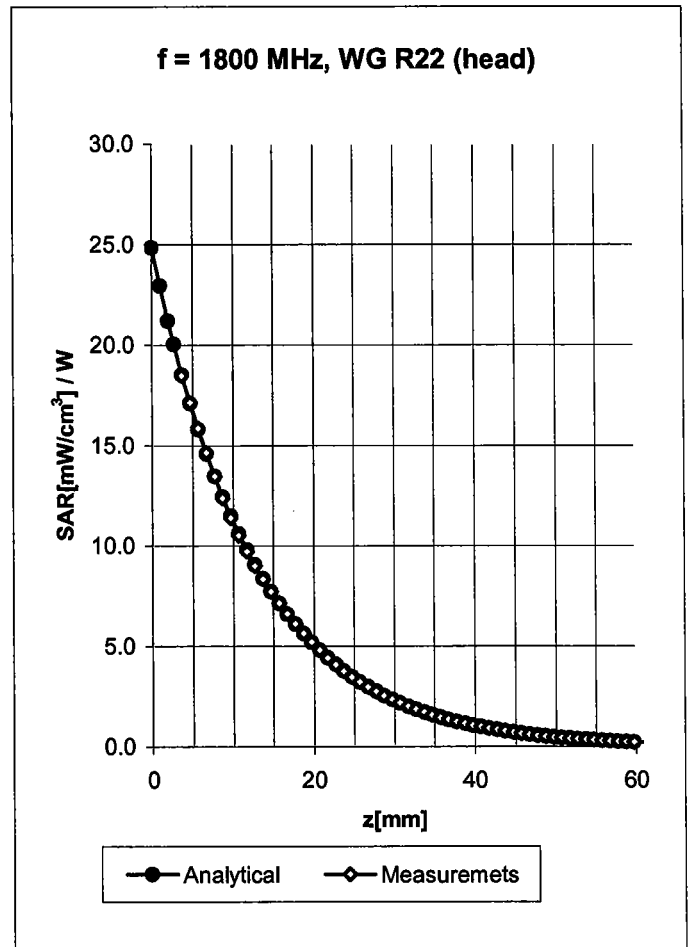
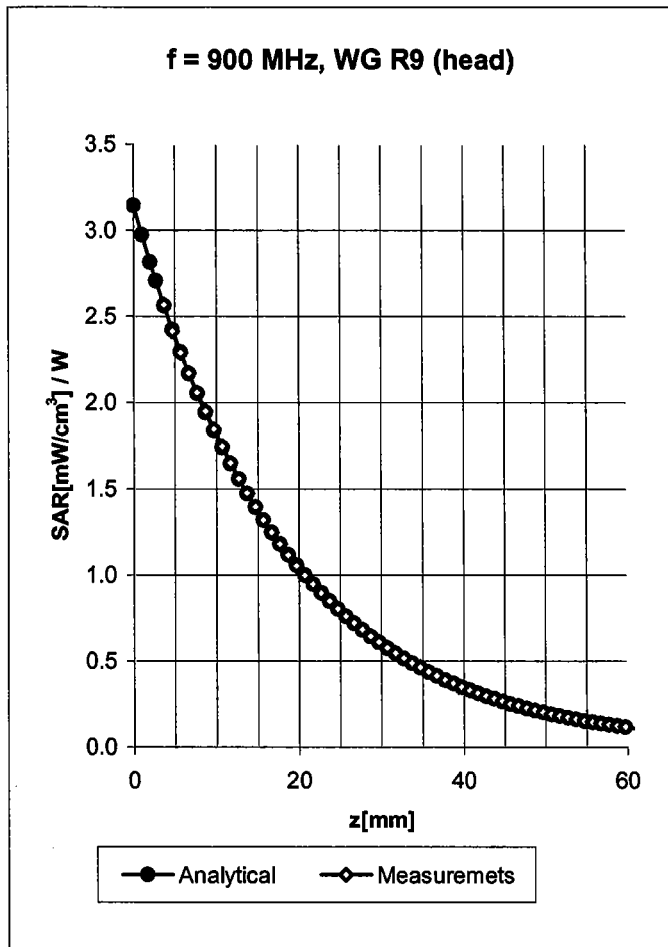

Head                      900 MHz                       $\epsilon_r = 41.5 \pm 5\%$                        $\sigma = 0.97 \pm 5\%$  mho/m

Valid for f=800-1000 MHz with Head Tissue Simulating Liquid according to EN 50361, P1528-200X

ConvF X	<b>6.5</b> $\pm 9.5\%$ (k=2)	Boundary effect:	
ConvF Y	<b>6.5</b> $\pm 9.5\%$ (k=2)	Alpha	<b>0.42</b>
ConvF Z	<b>6.5</b> $\pm 9.5\%$ (k=2)	Depth	<b>2.27</b>

Head                      1800 MHz                       $\epsilon_r = 40.0 \pm 5\%$                        $\sigma = 1.40 \pm 5\%$  mho/m

Valid for f=1710-1910 MHz with Head Tissue Simulating Liquid according to EN 50361, P1528-200X

ConvF X	<b>5.1</b> $\pm 9.5\%$ (k=2)	Boundary effect:	
ConvF Y	<b>5.1</b> $\pm 9.5\%$ (k=2)	Alpha	<b>0.50</b>
ConvF Z	<b>5.1</b> $\pm 9.5\%$ (k=2)	Depth	<b>2.63</b>

## Conversion Factor Assessment

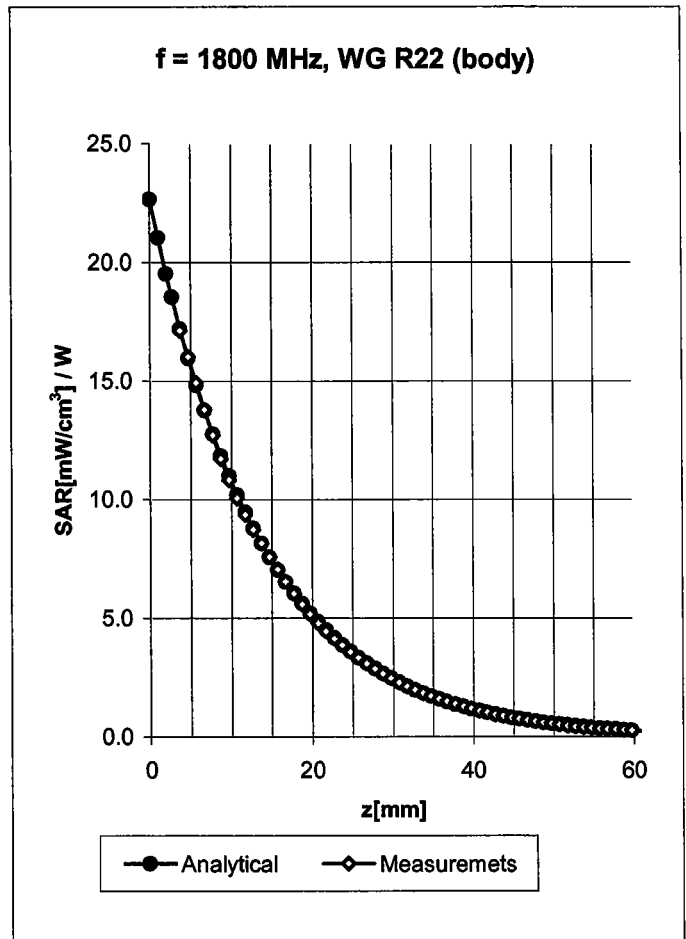
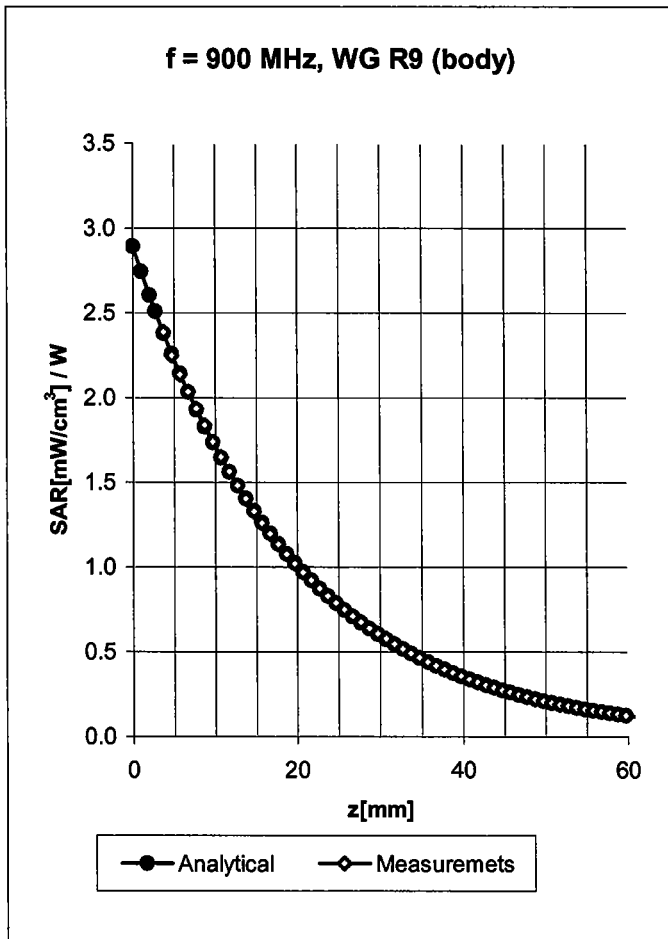

Body                      900 MHz                       $\epsilon_r = 55.0 \pm 5\%$                        $\sigma = 1.05 \pm 5\%$  mho/m

Valid for f=800-1000 MHz with Body Tissue Simulating Liquid according to OET 65 Suppl. C

ConvF X	<b>6.4</b> $\pm 9.5\%$ (k=2)	Boundary effect:	
ConvF Y	<b>6.4</b> $\pm 9.5\%$ (k=2)	Alpha	<b>0.44</b>
ConvF Z	<b>6.4</b> $\pm 9.5\%$ (k=2)	Depth	<b>2.29</b>

Body                      1800 MHz                       $\epsilon_r = 53.3 \pm 5\%$                        $\sigma = 1.52 \pm 5\%$  mho/m

Valid for f=1710-1910 MHz with Body Tissue Simulating Liquid according to OET 65 Suppl. C

ConvF X	<b>4.8</b> $\pm 9.5\%$ (k=2)	Boundary effect:	
ConvF Y	<b>4.8</b> $\pm 9.5\%$ (k=2)	Alpha	<b>0.57</b>
ConvF Z	<b>4.8</b> $\pm 9.5\%$ (k=2)	Depth	<b>2.61</b>

# Deviation from Isotropy in HSL

Error ( $\theta, \phi$ ),  $f = 900$  MHz

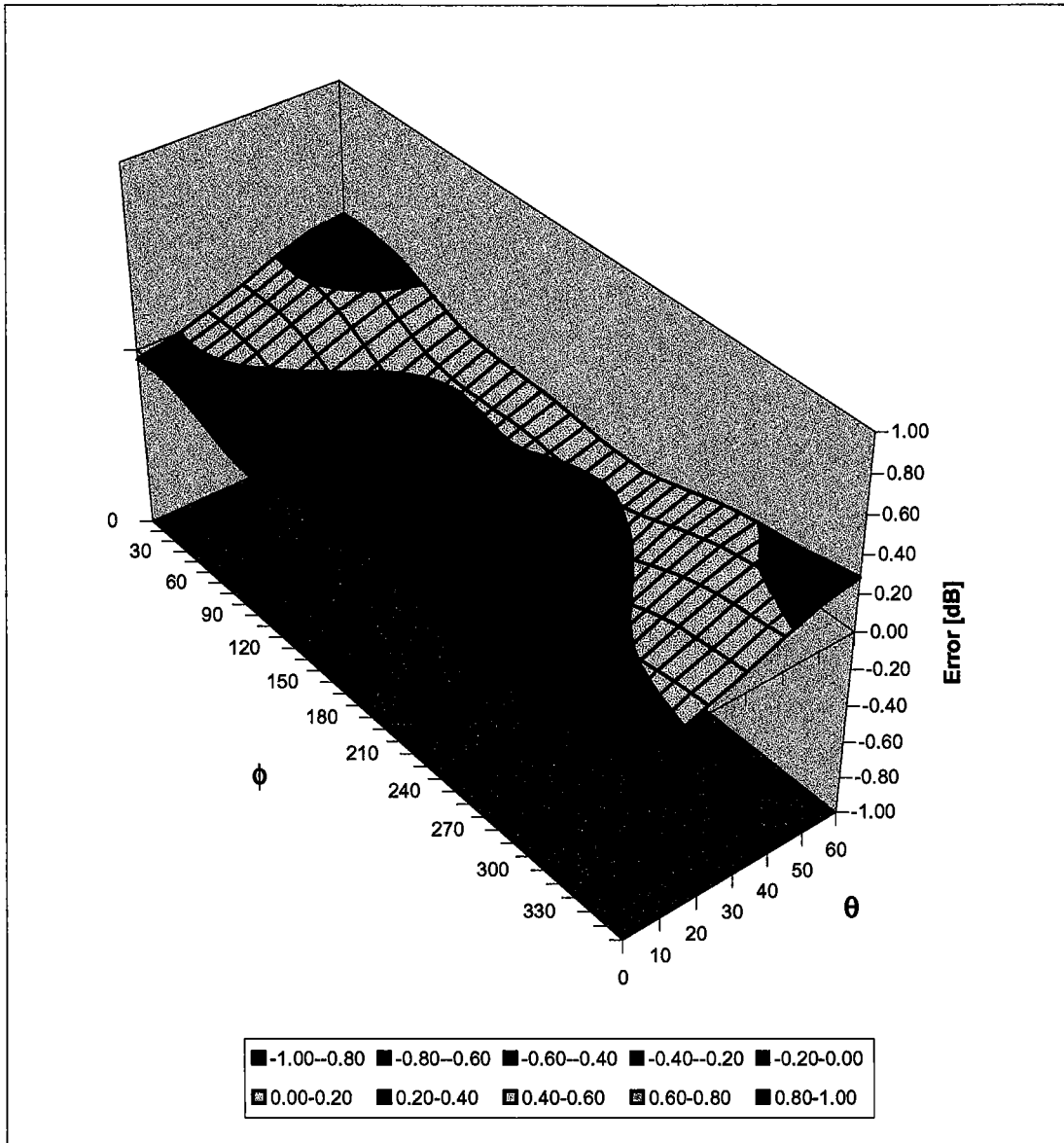

**Appendix 5**  
**Dipole Characterization Certificate**

# Certification of System Performance Check Targets

Based on APP-0396

-Historical Data-

	835MHz	900MHz	1800MHz	1900MHz	
<b>P1528 Target:</b> Advanced Extrapolation	9.5	10.8	38.1	39.7	(W/kg)
<b>Measurement Uncertainty (k=1):</b>	10.2%	10.2%	10.2%	10.2%	
<b>Measurement Period:</b>	November '02 - June '03	November '02 - June '03	November '02 - June '03	November '02 - June '03	
<b># of tests performed:</b>	169	728	868	26	
<b>Grand Average:</b> Worst Case Extrapolation	10.1	11.6	39.7	42.0	(W/kg)
<b>% Delta</b> (Average - P1528 Target)	6.5%	7.7%	4.2%	5.9%	
<b>Is % Delta &lt;= Measurement Uncertainty?</b>	Yes	Yes	Yes	Yes	
<b>Accept/Reject Average as new system performance check target?</b>	<b>ACCEPT</b>	<b>ACCEPT</b>	<b>ACCEPT</b>	<b>ACCEPT</b>	
	<b>Applicable 835MHz Dipole Serial Numbers:</b>	<b>Applicable 900MHz Dipole Serial Numbers:</b>	<b>Applicable 1800MHz Dipole Serial Numbers:</b>	<b>Applicable 1900MHz Dipole Serial Numbers:</b>	
	420(TR), 421(TR)	77, 78	246(TR), 250(TR)	514(TR), 518(TR)	
	422(TR), 423(TR)	79, 80	251(TR), 258(TR)	519(TR), 520(TR)	
	424(TR), 425(TR)	91, 92	259(TR), 262(TR)	523(TR), 524(TR)	
	431(TR), 432(TR)	93, 94	263(TR), 271(TR)	526(TR), 527(TR)	
	433(TR), 434(TR)	95, 96	272(TR), 273(TR)	528(TR), 529(TR)	
	436(TR)	97	276(TR), 277(TR)	530(TR), 533(TR)	
			279(TR), 280(TR)		
			281(TR), 282(TR)		
			283(TR), 284(TR)		

-New System Performance Check Targets- per APP-0396

(based on analysis of historical data)

Frequency	SAR Target (W/kg)	Permittivity	Conductivity (S/m)
<b>835MHz</b>	<b>10.1</b>	41.5 ± 5%	0.90 ± 5%
<b>900MHz</b>	<b>11.6</b>	41.5 ± 5%	0.97 ± 5%
<b>1800MHz</b>	<b>39.7</b>	40.0 ± 5%	1.40 ± 5%
<b>1900MHz</b>	<b>42.0</b>	40.0 ± 5%	1.40 ± 5%

-Approvals-

Submitted by:  Date:

Signed: *Marge Kaunas*

Comments:

Approved by:  Date:

Signed: *Antonio Faraone*

Comments:

**Appendix 6**  
**Measurement Uncertainty Budget**

<b>Uncertainty Budget for Device Under Test</b>									
<i>a</i>	<i>b</i>	<i>c</i>	<i>d</i>	<i>e = f(d,k)</i>	<i>f</i>	<i>g</i>	<i>h = c x f / e</i>	<i>i = c x g / e</i>	<i>k</i>
<b>Uncertainty Component</b>	Sec.	Tol. (± %)	Prob. Dist.	Div.	<i>c<sub>i</sub></i> (1 g)	<i>c<sub>i</sub></i> (10 g)	1 g <i>u<sub>i</sub></i> (±%)	10 g <i>u<sub>i</sub></i> (±%)	<i>v<sub>i</sub></i>
<b>Measurement System</b>									
Probe Calibration	E.2.1	9.5	N	2.00	1	1	4.8	4.8	∞
Axial Isotropy	E.2.2	4.7	R	1.73	0.707	0.707	1.9	1.9	∞
Spherical Isotropy	E.2.2	9.6	R	1.73	0.707	0.707	3.9	3.9	∞
Boundary Effect	E.2.3	5.8	R	1.73	1	1	3.3	3.3	∞
Linearity	E.2.4	4.7	R	1.73	1	1	2.7	2.7	∞
System Detection Limits	E.2.5	1.0	R	1.73	1	1	0.6	0.6	∞
Readout Electronics	E.2.6	1.0	N	1.00	1	1	1.0	1.0	∞
Response Time	E.2.7	0.8	R	1.73	1	1	0.5	0.5	∞
Integration Time	E.2.8	1.3	R	1.73	1	1	0.8	0.8	∞
RF Ambient Conditions	E.6.1	3.0	R	1.73	1	1	1.7	1.7	∞
Probe Positioner Mechanical Tolerance	E.6.2	0.3	R	1.73	1	1	0.2	0.2	∞
Probe Positioning with respect to Phantom Shell	E.6.3	1.1	R	1.73	1	1	0.6	0.6	∞
Extrapolation, interpolation and Integration Algorithms for Max. SAR Evaluation	E.5	3.9	R	1.73	1	1	2.3	2.3	∞
<b>Test sample Related</b>									
Test Sample Positioning	E.4.2	3.6	N	1.00	1	1	3.6	3.6	29
Device Holder Uncertainty	E.4.1	2.8	N	1.00	1	1	2.8	2.8	8
Output Power Variation - SAR drift measurement	6.6.2	5.0	R	1.73	1	1	2.9	2.9	∞
<b>Phantom and Tissue Parameters</b>									
Phantom Uncertainty (shape and thickness tolerances)	E.3.1	4.0	R	1.73	1	1	2.3	2.3	∞
Liquid Conductivity - deviation from target values	E.3.2	5.0	R	1.73	0.64	0.43	1.8	1.2	∞
Liquid Conductivity - measurement uncertainty	E.3.3	10.0	R	1.73	0.64	0.43	3.7	2.5	∞
Liquid Permittivity - deviation from target values	E.3.2	10.0	R	1.73	0.6	0.49	3.5	2.8	∞
Liquid Permittivity - measurement uncertainty	E.3.3	5.0	R	1.73	0.6	0.49	1.7	1.4	∞
<b>Combined Standard Uncertainty</b>			RSS				11.72	11.09	1363
<b>Expanded Uncertainty (95% CONFIDENCE LEVEL)</b>			<i>k</i> =2				22.98	21.75	

**Uncertainty Budget for System Performance Check (dipole & flat phantom)**

<i>a</i>	<i>b</i>	<i>c</i>	<i>d</i>	$e = f(d,k)$	<i>f</i>	<i>g</i>	$h = c \times f / e$	$i = c \times g / e$	<i>k</i>
<b>Uncertainty Component</b>	Sec.	Tol. (± %)	Prob. Dist.	Div.	<i>c<sub>i</sub></i> (1 g)	<i>c<sub>i</sub></i> (10 g)	1 g <i>u<sub>i</sub></i> (±%)	10 g <i>u<sub>i</sub></i> (±%)	<i>v<sub>i</sub></i>
<b>Measurement System</b>									
Probe Calibration	E.2.1	9.5	N	2.00	1	1	4.8	4.8	∞
Axial Isotropy	E.2.2	4.7	R	1.73	1	1	2.7	2.7	∞
Spherical Isotropy	E.2.2	9.6	R	1.73	0	0	0.0	0.0	∞
Boundary Effect	E.2.3	5.8	R	1.73	1	1	3.3	3.3	∞
Linearity	E.2.4	4.7	R	1.73	1	1	2.7	2.7	∞
System Detection Limits	E.2.5	1.0	R	1.73	1	1	0.6	0.6	∞
Readout Electronics	E.2.6	1.0	N	1.00	1	1	1.0	1.0	∞
Response Time	E.2.7	0.0	R	1.73	1	1	0.0	0.0	∞
Integration Time	E.2.8	0.0	R	1.73	1	1	0.0	0.0	∞
RF Ambient Conditions	E.6.1	3.0	R	1.73	1	1	1.7	1.7	∞
Probe Positioner Mechanical Tolerance	E.6.2	0.3	R	1.73	1	1	0.2	0.2	∞
Probe Positioning with respect to Phantom Shell	E.6.3	1.1	R	1.73	1	1	0.6	0.6	∞
Extrapolation, interpolation and Integration Algorithms for Max. SAR Evaluation	E.5	3.9	R	1.73	1	1	2.3	2.3	∞
<b>Dipole</b>									
Dipole Axis to Liquid Distance	8, E.4.2	1.0	R	1.73	1	1	0.6	0.6	∞
Input Power and SAR Drift Measurement	8, 6.6.2	4.7	R	1.73	1	1	2.7	2.7	∞
<b>Phantom and Tissue Parameters</b>									
Phantom Uncertainty (shape and thickness tolerances)	E.3.1	4.0	R	1.73	1	1	2.3	2.3	∞
Liquid Conductivity - deviation from target values	E.3.2	5.0	R	1.73	0.64	0.43	1.8	1.2	∞
Liquid Conductivity - measurement uncertainty	E.3.3	10.0	R	1.73	0.64	0.43	3.7	2.5	∞
Liquid Permittivity - deviation from target values	E.3.2	10.0	R	1.73	0.6	0.49	3.5	2.8	∞
Liquid Permittivity - measurement uncertainty	E.3.3	5.0	R	1.73	0.6	0.49	1.7	1.4	∞
<b>Combined Standard Uncertainty</b>			RSS				10.16	9.43	99999
<b>Expanded Uncertainty (95% CONFIDENCE LEVEL)</b>			<i>k</i> =2				19.92	18.48	

## **Appendix 7**

### **Photographs of the device under test**



