



September 4, 1998

SAR Test Report for Motorola portable cellular phone (FCC ID IHDT5YD1).

Prepared by:

Paul Moller, Senior Staff Engineer

Motorola Personal Communications Sector Product Safety Lab

Libertyville, Illinois

## Contents

- 1) Introduction
- 2) Applicable Regulations
- 3) Description of Test Sample
- 4) Description of Motorola SAR Test Facility
- 5) Test Sample Conditions
- 6) Method of Measurement
- 7) SAR Test Results
- 8) Summary

Appendix A: Included data

Appendix B: SAR Measurement Operational Guide

## 1. Introduction

The Motorola Personal Communications Sector Product Safety Laboratory has performed measurements of the maximum potential exposure to the user of portable cellular phone FCC ID IHDT5YD1. The Specific Absorption Rate (SAR) of this product was measured. This report details the test setup and equipment as well as the results of those tests.

## 2. Applicable Regulations

Federal Communications Commission rule §2.1093(d)(2), the ANSI/IEEE C95.1 1992 and the NCRP Report Number 86 specify the maximum exposure limit of 1.6 W/kg as averaged over any 1 gram of tissue for portable devices being used within 20cm of the user in the uncontrolled environment.

## 3. Description of Test Sample

A prototype unit serial number VJXN3N0 was measured. This unit is identical in physical construction, maximum radiated power levels and antenna structure to units that will be in production. It transmits in the frequency range of 824 to 849 MHz using AMPS, NAMPS and CDMA modes. The maximum average transmit power for this test unit is 0.5 Watt in analog modes, and 0.25 Watt in digital mode.

The unit is equipped with a telescoping antenna that serves as both a receive and transmit antenna. The antenna has a retracted and an extended operating position as shown in figures 1 and 2 respectively.



Figure 1.



Figure 2.

Figures 3 and 4 show the test unit as it is placed onto the phantom head with the antenna in the extended and retracted positions respectively. For the purposes of the actual SAR tests the phantom head is tilted on its side by 90 degrees so that a vertically oriented measurement probe can easily scan an area where the phone is in close contact with the phantom and the SAR will be the highest.



Figure 3.



Figure 4.

#### 4. SAR Test Facility

The Motorola test facility utilized for the SAR testing of this product is the Personal Communications Sector Product Safety Laboratory, in Libertyville Illinois. The laboratory utilizes an SAR measurement system developed by Motorola and manufactured by IDX Robotics™ of Corvallis, Oregon. This system utilizes a computer controlled six axis robot to move a measurement probe to measure the SAR. The probe is calibrated at the Florida Corporate Electromagnetics Laboratory in Plantation Florida, using a procedure developed by Dr. Q. Balzano. The measurement methodology is described in IEEE Transactions on Vehicular Technology, vol. 44, no. 3, August 1995, titled Electromagnetic Energy Exposure of Simulated users of Portable Cellular Telephones.

Furthermore, a copy of the document "SAR Measurement Operational Guide", dated December 1997, is attached as appendix B for reference purposes. This Motorola document describes the measurement setup and rationale in detail.

## 5. Test Sample Conditions

For the purposes of these tests the subject phone was positioned on the measurement phantom per the instructions in the Motorola users manual for the subject phone. SAR was measured with the antenna in both the retracted and extended positions. Since the antenna is not located on the center of the phone, the SAR was measured with the phone on both the left and right side talk positions (See figures 3 and 4). Due to the construction of the phone, the base of the antenna is 23 mm away from the cheek of the phantom in all cases.

The test sample is capable of operation in a test mode that allows control of the transmitter without the need to place actual phone calls. This guarantees that the unit does not change its transmitter power, and that the resultant SAR values will not be affected by external connections. For the purposes of this test the unit is commanded to test mode and manually set to the proper channel, transmitter power level and transmit mode of operation. The phone is then placed in the SAR measurement system with a fully charged battery. At the end of each test the unit is measured for RF power out so as to ensure that the test was evaluating the maximum SAR level. For the purposes of these tests, the transmitter was operated at the highest transmitter output level in both the analog and digital modes, with the antenna in both the extended and retracted positions, and with the phone on both left and right side talk positions.

## 6. Method of Measurement

For each antenna position the system is instructed to scan as much of the face of the phone as is in close proximity to the phantom. Using the information gained about the general region of highest SAR, the system then automatically scans a smaller area centered around the location of peak spatial SAR. Once the precise location of highest SAR is found, the system then automatically measures the fall off of electric field strength as the measurement probe is moved away from the inner surface of the phantom in the direction of the local normal to the phantom surface. Using appropriate probe calibration techniques, the SAR in 1 gram of phantom tissue is then calculated. The phantom head shown in figures 3 and 4, was filled with a liquid having relative dielectric constant equal to 40 and conductivity equal to 0.85 S/m. This mixture is a good dielectric equivalent of the gray matter of the human brain. The composition of the liquid mixture is as follows: 42.5% water; 55.6% sugar; 0.8% salt, 1% HEC; and 0.1% bactericide.

## 7. SAR Test Results

Figure 5 shows the phone overlaid with a typical contour plot. Also shown are cross hair lines showing the +X and +Y directions. The intersection of these lines represents the 0,0 location (origin) of the robot's scan area. The phone is placed on the phantom's head with the origin at the center of the ear, and the center line of the phone extends downward to meet the center of the phantom's mouth. This is the X-axis, and the direction from the microphone to the speaker is the +X direction, as indicated in the figure, and the +Y direction is as shown in figure. The same origin, axes and phone position are used for both extended and retracted antenna positions and for left and right side talk positions. For left side head the direction of +X becomes -X and likewise for Y directions.

The maximum SAR level for the Motorola portable cellular phone (FCC ID IHDT5YD1) is 0.54 W/kg and was found to be with the antenna in the extended position on the left side head, and

with the phone in analog mode. The highest SAR found in digital mode was 0.24 W/kg. The maximum SAR with the antenna retracted is lower than with the antenna extended because the antenna is matched better to the transmitter in the extended position and thus the radiated power is slightly higher. A full data set output of three test conditions with the highest SAR values from the IDX measurement system is included as appendix A. The test conditions included are indicated as bold numbers in the following table. All other test conditions measured lower SAR values than those included. Note that digital mode SAR data was measured only for the highest antenna positions in analog mode. This is because the only difference between analog and digital modes that can impact SAR is the average transmitter power.

Channel	Analog mode				Digital mode			
	Left side head		Right side head		Left side head		Right side head	
	Extended	Retracted	Extended	Retracted	Extended	Retracted	Extended	Retracted
991	<b>0.54</b>	0.36	0.40	0.35	<b>0.24</b>			
383	0.41	0.32	0.48	<b>0.42</b>				0.19
799	0.36	0.41	0.48	0.33				



Figure 5.

## 8. Summary

The SAR values found for the portable cellular phone (FCC ID IHDT5YD1) are below the maximum recommended levels of 1.6 W/kg.

#### Appendix A

The following pages are printouts from the IDX measurement system of the data as indicated.

File : c:/idx3/SYSTEM/SARMEAS3/data/Normal/98082111\_ZOOM.VLT  
Start : 21-Aug-98 10:15:47 am End : 21-Aug-98 10:23:42 am

Radio Type : Motorola  
Model Number : swf3570a  
Serial Number : vjxn3n0  
Frequency : 824.04 MHz  
Peak Trans. Pwr : 0.500 W  
Start Trans. Pwr : 0.500 W  
Antenna Type : End Fed  
Antenna Posn. : Out  
Phantom Type : Head  
Phantom Posn. : Left Ear  
Scan Type : ZOOM/SAR  
Probe Name : Probe036  
Field Type : E Field  
Orientation : 90 Degrees

Mixture Type = Brain  
Mixture Dielectric Constant = 40.000  
Mixture Conductivity = 0.850

Comment :  
ch991/pwr2/wd=1.19/et

Robot : ROBOT 4

Probe Offset = 0.27 cm  
Sensor Factor = 0.0108  
Conversion Factor = 0.612

Probe036 Amplifier Channel Settings : 0.211 0.146 0.117

Max Location : X = -1.000, Y = 5.500, Z = 0.000 (cm) Value = 10.747

Measured Values (volts) =  
1.078E-002 4.456E-003 3.091E-003 2.267E-003 1.631E-003 1.069E-003  
7.455E-004 5.252E-004 4.307E-004 3.562E-004 2.698E-004

Calc. Voltage @ Surface (Vs) = 0.0154

Voltage @ 1.00 cm (Vt) = 0.0038

Ave. Voltage (Vs+Vt)/2 = 0.0096

Ave. SAR over 1 g (mW/g) = 0.5442

File : 98082111\_ZOOM.VLT

Start : 21-Aug-98 10:15:47 am End : 21-Aug-98 10:23:42 am

Motorola/swf3570a/vjxn3n0;824.04MHz;0.500 W;End Fed/Out;

Head/Left Ear;ZOOM/SAR;Probe036/E Field/90 DegreesBrain/40.000/0.850

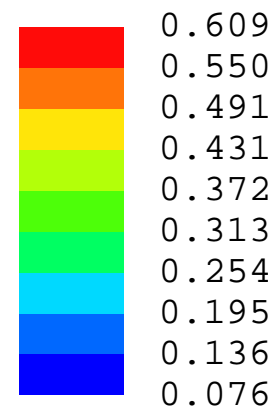
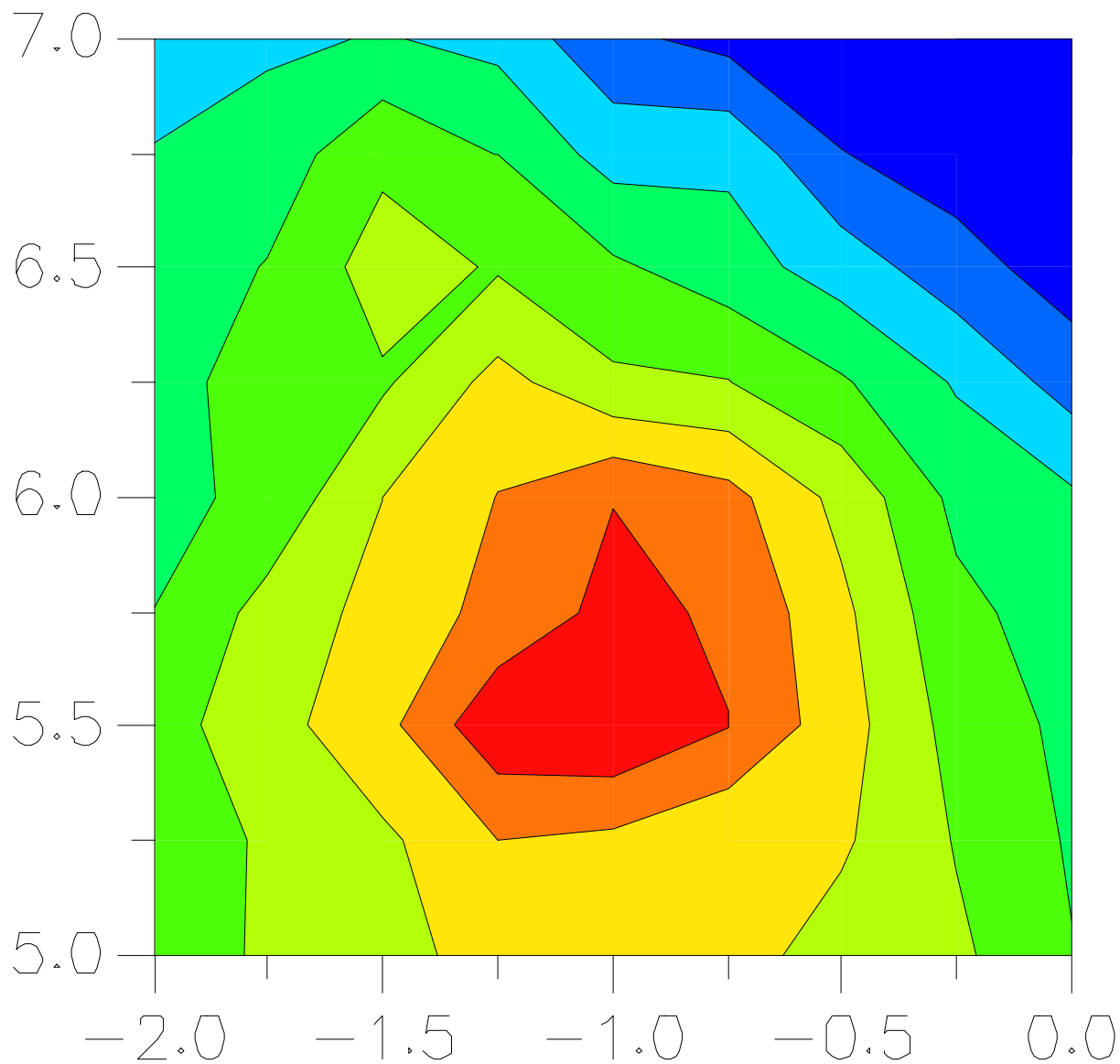

File : 98082111\_ZOOM.VLT

Start : 21-Aug-98 10:15:47 am End : 21-Aug-98 10:23:42 am

Motorola/swf3570a/vjxn3n0;824.04MHz;0.500 W;End Fed/Out;

Head/Left Ear;ZOOM/SAR;Probe036/E Field/90 DegreesBrain/40.000/0.850

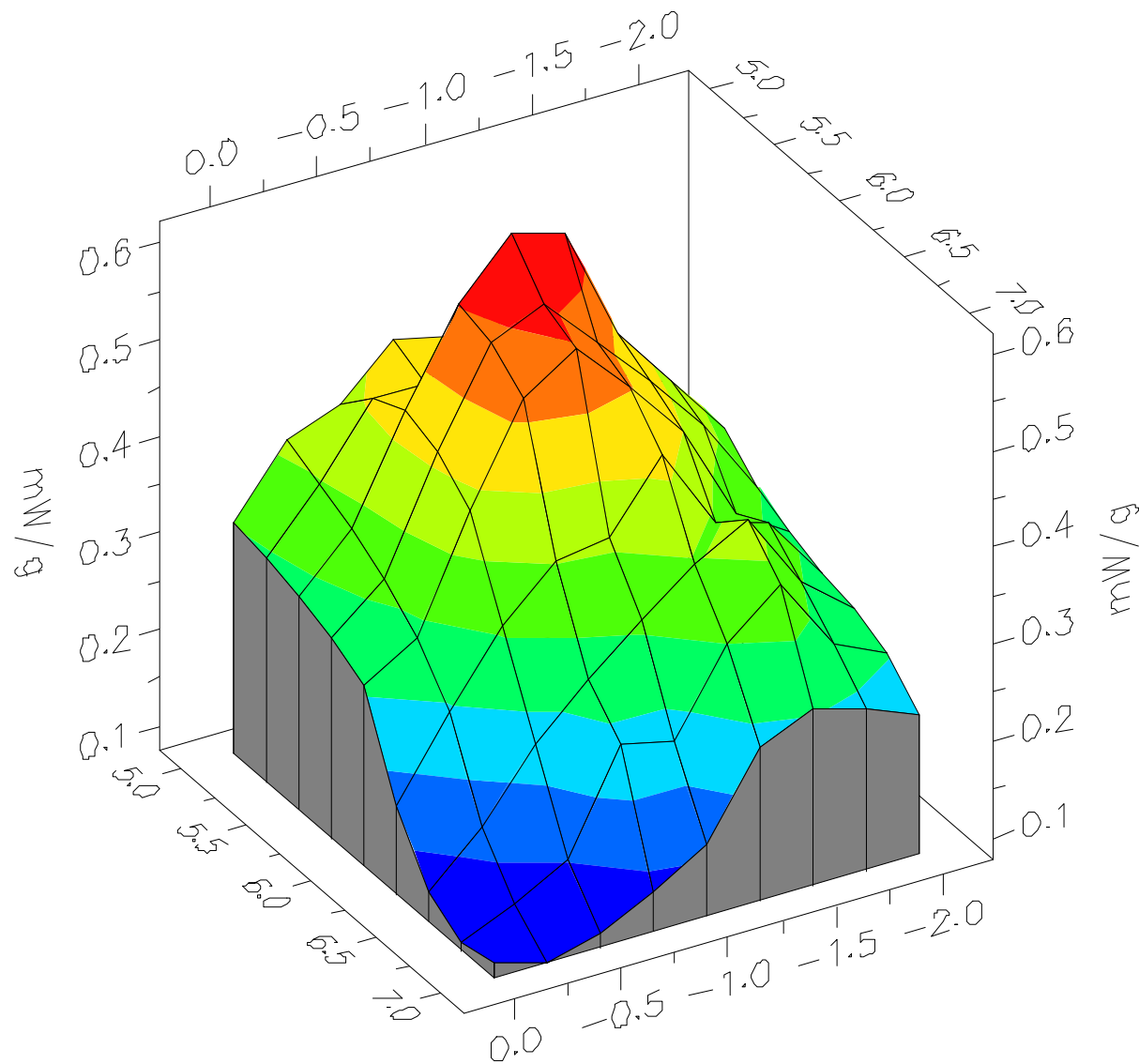

SAR Scan  
File : 98082111\_ZOOM.VLT  
Start : 21-Aug-98 10:15:47 am End : 21-Aug-98 10:23:42 am  
Motorola/swf3570a/vjxn3n0;824.04MHz;0.500 W;End Fed/Out;  
Head/Left Ear;ZOOM/SAR;Probe036/E Field/90 DegreesBrain/40.000/0.850

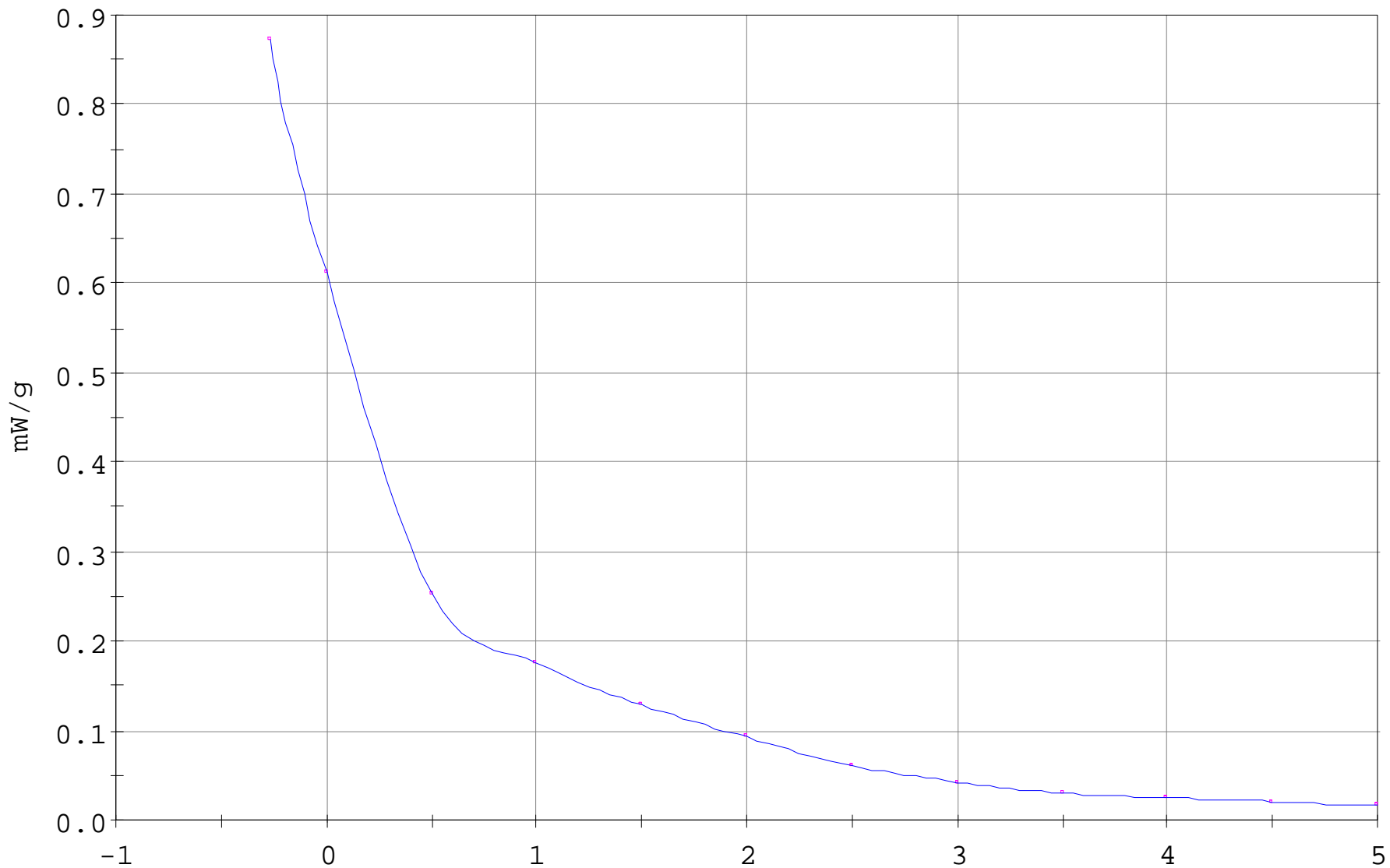

File : c:/idx3/SYSTEM/SARMEAS3/data/Normal/98082111\_AREA.VLT  
Start : 21-Aug-98 10:08:28 am End : 21-Aug-98 10:15:47 am

Radio Type : Motorola  
Model Number : swf3570a  
Serial Number : vjxn3n0  
Frequency : 824.04 MHz  
Peak Trans. Pwr : 0.500 W  
Start Trans. Pwr : 0.500 W  
Antenna Type : End Fed  
Antenna Posn. : Out  
Phantom Type : Head  
Phantom Posn. : Left Ear  
Scan Type : AREA  
Probe Name : Probe036  
Field Type : E Field  
Orientation : 90 Degrees

Mixture Type = Brain  
Mixture Dielectric Constant = 40.000  
Mixture Conductivity = 0.850

Comment :  
ch991/pwr2/wd=1.19/et

Robot : ROBOT 4

Probe Offset = 0.27 cm  
Sensor Factor = 0.0108  
Conversion Factor = 0.612

Probe036 Amplifier Channel Settings : 0.211 0.146 0.117

Max Location : X = -1.000, Y = 6.000, Z = 0.000 (cm) Value = 9.686

Area too wide. SAR value not calculated. Will be calculated on zoom scan.

File : 98082111\_AREA.VLT

Start : 21-Aug-98 10:08:28 am End : 21-Aug-98 10:15:47 am

Motorola/swf3570a/vjxn3n0;824.04MHz;0.500 W;End Fed/Out;

Head/Left Ear;AREA;Probe036/E Field/90 DegreesBrain/40.000/0.850

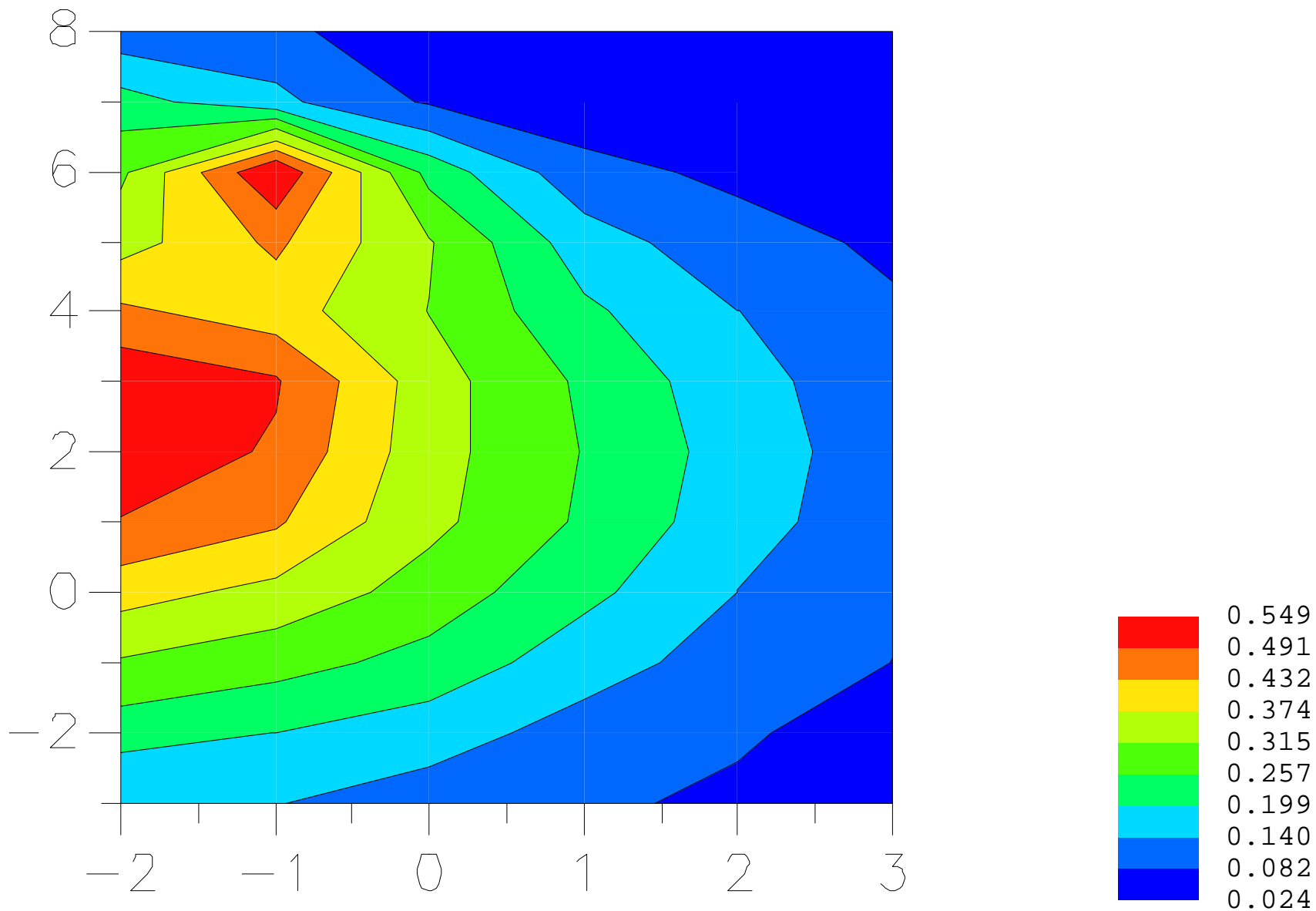

File : 98082111\_AREA.VLT

Start : 21-Aug-98 10:08:28 am End : 21-Aug-98 10:15:47 am

Motorola/swf3570a/vjxn3n0;824.04MHz;0.500 W;End Fed/Out;

Head/Left Ear;AREA;Probe036/E Field/90 DegreesBrain/40.000/0.850

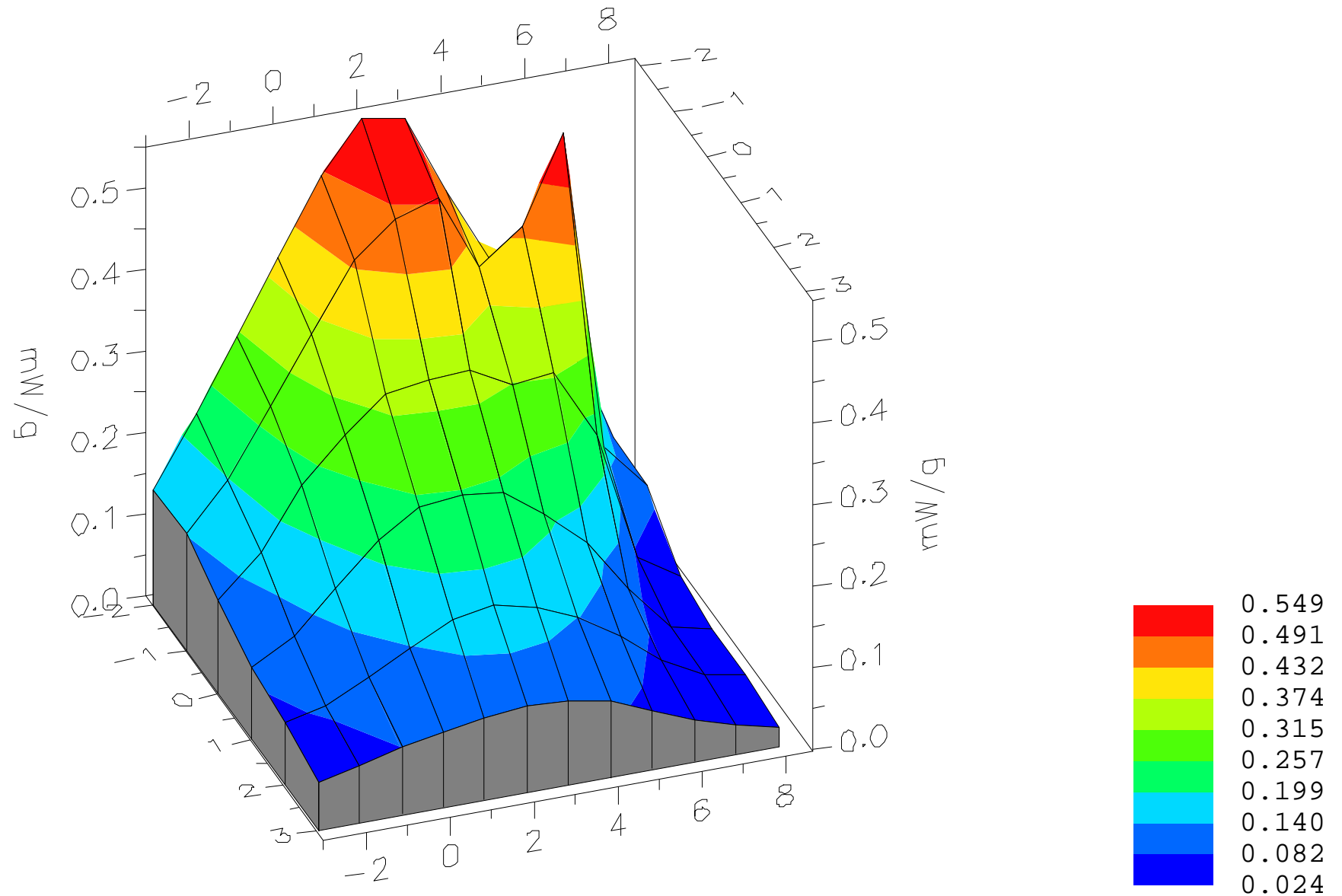

X-Z Plane Slice Y=6.000  
File : 98082111\_AREA.VLT  
Start : 21-Aug-98 10:08:28 am End : 21-Aug-98 10:15:47 am  
Motorola/swf3570a/vjxn3n0;824.04MHz;0.500 W;End Fed/Out;  
Head/Left Ear;AREA;Probe036/E Field/90 DegreesBrain/40.000/0.850

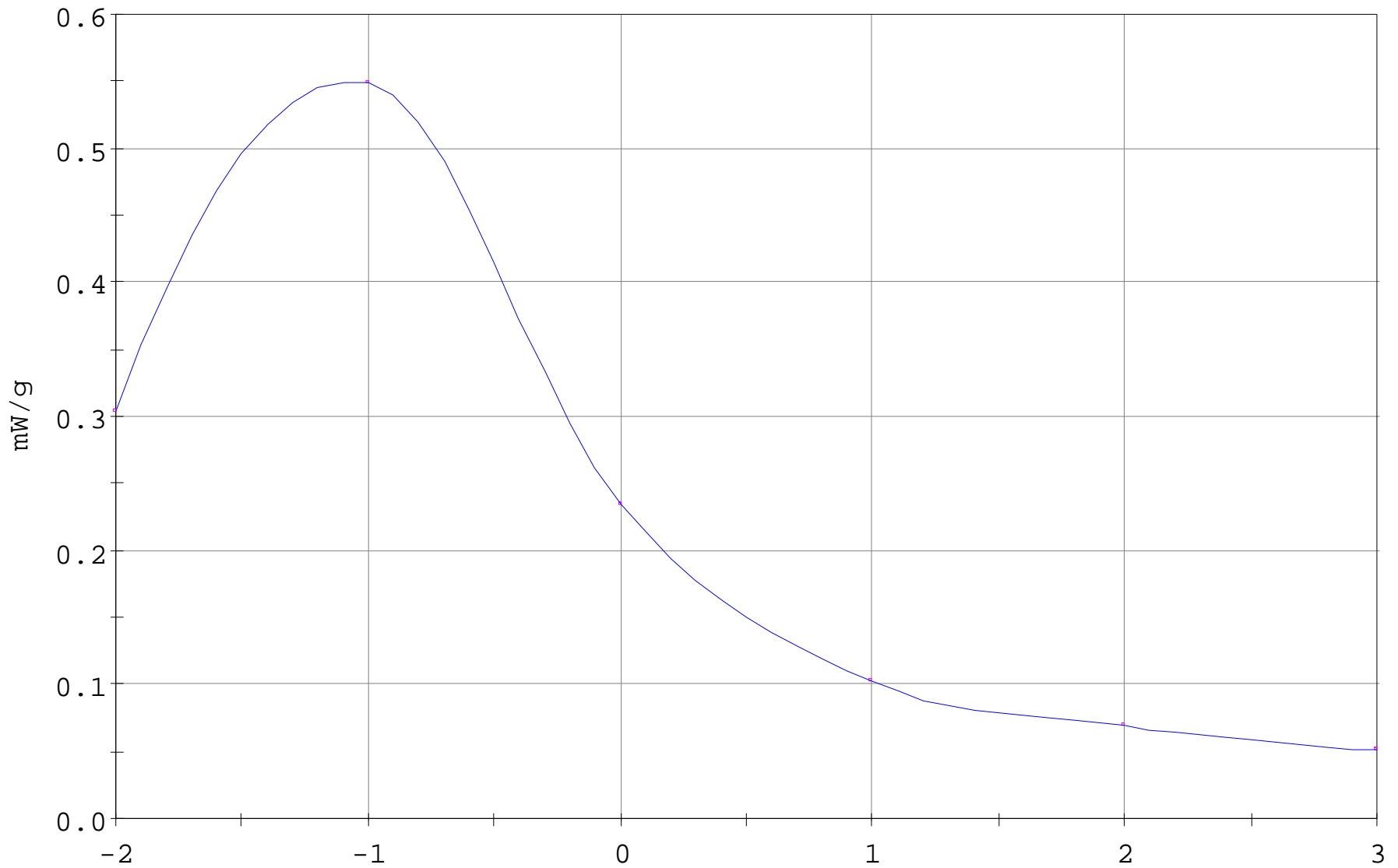

File : c:/idx3/SYSTEM/SARMEAS3/data/Normal/98090106\_ZOOM.VLT  
Start : 1-Sep-98 11:29:38 am End : 1-Sep-98 11:34:56 am

Radio Type : Motorola  
Model Number : swf3570a  
Serial Number : vjxn3n0  
Frequency : 836.49 MHz  
Peak Trans. Pwr : 0.500 W  
Start Trans. Pwr : 0.500 W  
Antenna Type : Helical  
Antenna Posn. : In  
Phantom Type : Head  
Phantom Posn. : Right Ear  
Scan Type : ZOOM/SAR  
Probe Name : 034  
Field Type : E Field  
Orientation : 0 Degrees

Mixture Type = Brain  
Mixture Dielectric Constant = 41.000  
Mixture Conductivity = 0.850

Comment :  
chan383/pwr2/wdot=1.28/jk  
analog

Robot : ROBOT1

Probe Offset = 0.28 cm  
Sensor Factor = 0.0108  
Conversion Factor = 0.691

034 Amplifier Channel Settings : 0.165 0.127 0.108

Max Location : X = -7.750, Y = -4.000, Z = 0.000 (cm) Value = 7.229

Measured Values (volts) =  
6.848E-003 6.060E-003 4.393E-003 3.362E-003 2.763E-003 2.270E-003  
1.885E-003 1.470E-003 1.094E-003 8.218E-004 6.735E-004

Calc. Voltage @ Surface (Vs) = 0.0078

Voltage @ 1.00 cm (Vt) = 0.0053

Ave. Voltage (Vs+Vt)/2 = 0.0066

Ave. SAR over 1 g (mW/g) = 0.4192

File : 98090106\_ZOOM.VLT

Start : 1-Sep-98 11:29:38 am End : 1-Sep-98 11:34:56 am

Motorola/swf3570a/vjxn3n0;836.49MHz;0.500 W;Helical/;

Head/Right Ear;ZOOM/SAR;034/E Field/0 DegreesBrain/41.000/0.850

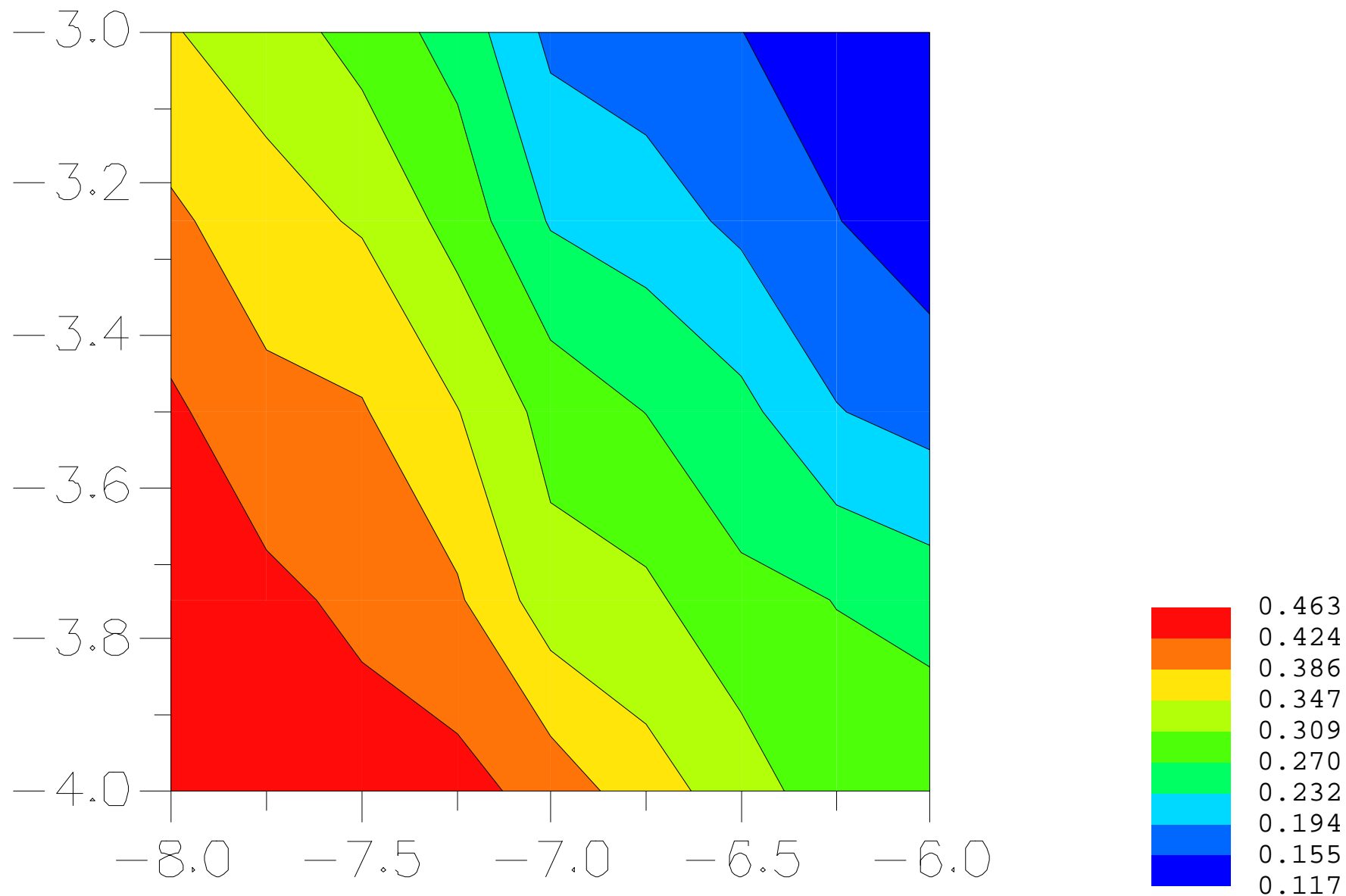

File : 98090106\_ZOOM.VLT

Start : 1-Sep-98 11:29:38 am End : 1-Sep-98 11:34:56 am

Motorola/swf3570a/vjxn3n0;836.49MHz;0.500 W;Helical/;

Head/Right Ear;ZOOM/SAR;034/E Field/0 DegreesBrain/41.000/0.850

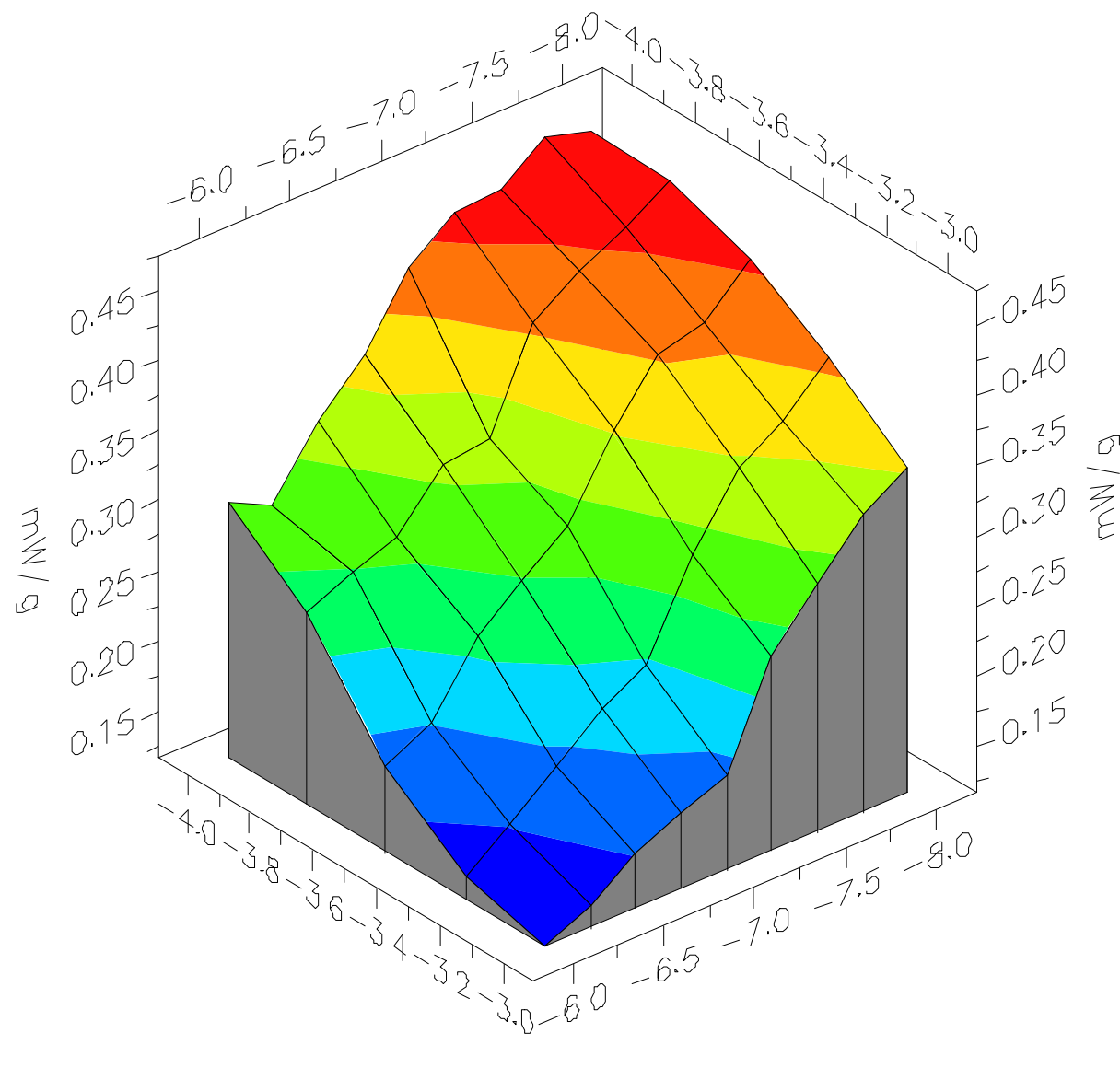

SAR Scan  
File : 98090106\_ZOOM.VLT  
Start : 1-Sep-98 11:29:38 am End : 1-Sep-98 11:34:56 am  
Motorola/swf3570a/vjxn3n0;836.49MHz;0.500 W;Helical/  
Head/Right Ear;ZOOM/SAR;034/E Field/0 DegreesBrain/41.000/0.850

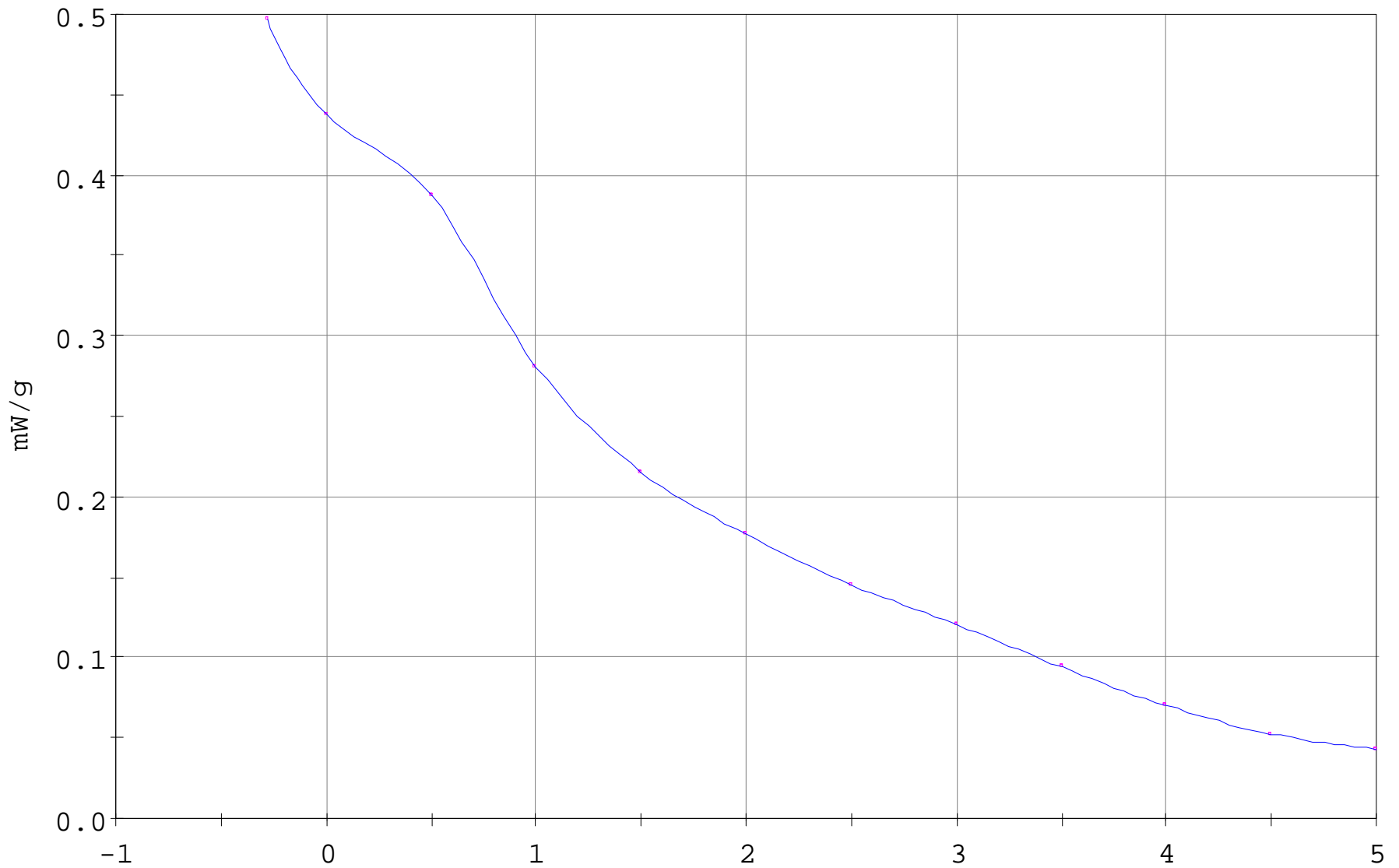

File : c:/idx3/SYSTEM/SARMEAS3/data/Normal/98090106\_AREA.VLT  
Start : 1-Sep-98 11:18:40 am End : 1-Sep-98 11:29:38 am

Radio Type : Motorola  
Model Number : swf3570a  
Serial Number : vjxn3n0  
Frequency : 836.49 MHz  
Peak Trans. Pwr : 0.500 W  
Start Trans. Pwr : 0.500 W  
Antenna Type : Helical  
Antenna Posn. : In  
Phantom Type : Head  
Phantom Posn. : Right Ear  
Scan Type : AREA  
Probe Name : 034  
Field Type : E Field  
Orientation : 0 Degrees

Mixture Type = Brain  
Mixture Dielectric Constant = 41.000  
Mixture Conductivity = 0.850

Comment :  
chn383/pwr2/wd1.28/jk  
analog

Robot : ROBOT1

Probe Offset = 0.28 cm  
Sensor Factor = 0.0108  
Conversion Factor = 0.691

034 Amplifier Channel Settings : 0.165 0.127 0.108

Max Location : X = -7.000, Y = -4.000, Z = 0.000 (cm) Value = 6.416

Area too wide. SAR value not calculated. Will be calculated on zoom scan.

File : 98090106\_AREA.VLT

Start : 1-Sep-98 11:18:40 am End : 1-Sep-98 11:29:38 am

Motorola/swf3570a/vjxn3n0;836.49MHz;0.500 W;Helical/;

Head/Right Ear;AREA;034/E Field/0 DegreesBrain/41.000/0.850

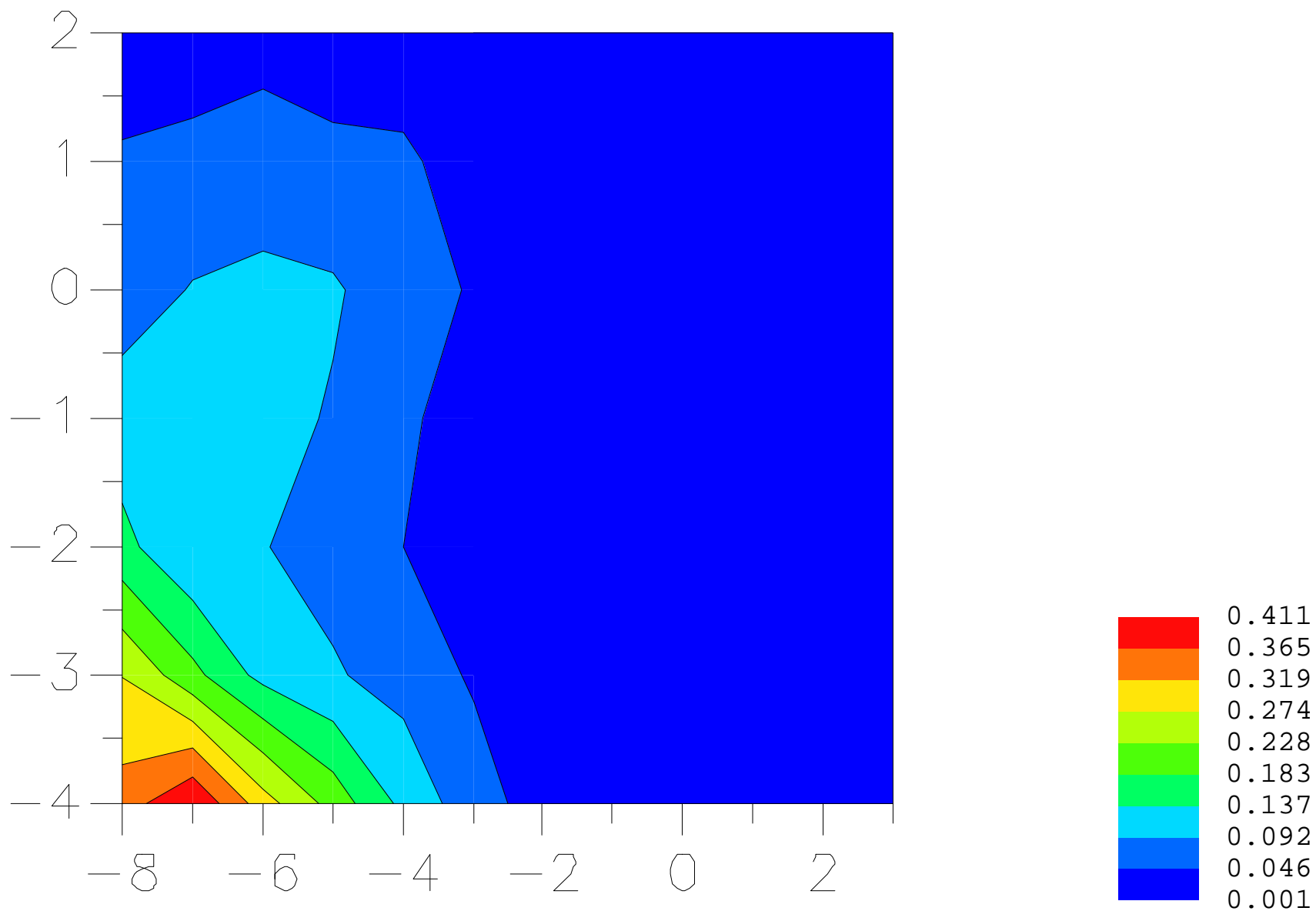

File : 98090106\_AREA.VLT

Start : 1-Sep-98 11:18:40 am End : 1-Sep-98 11:29:38 am

Motorola/swf3570a/vjxn3n0;836.49MHz;0.500 W;Helical/;

Head/Right Ear;AREA;034/E Field/0 DegreesBrain/41.000/0.850

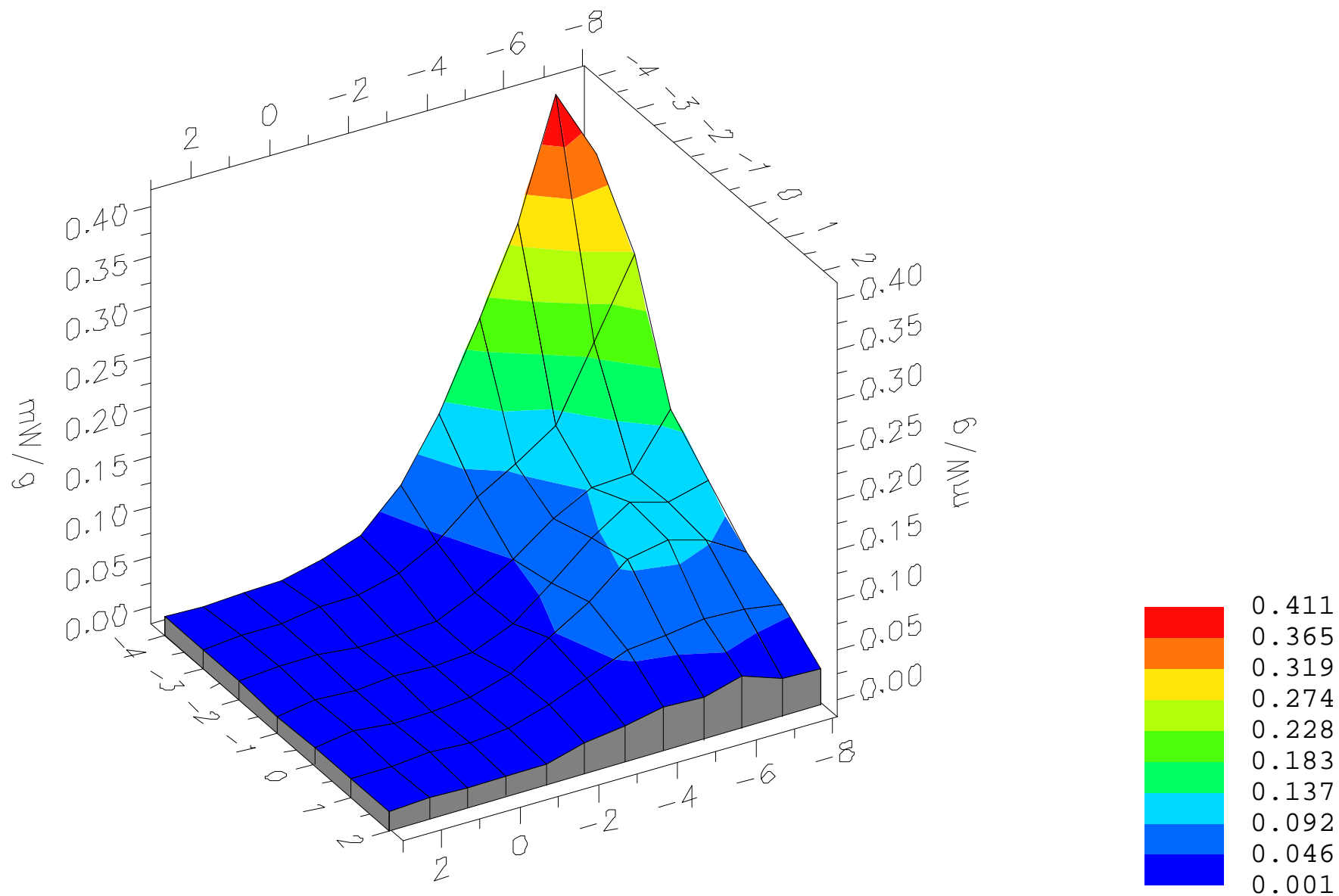

X-Z Plane Slice Y=-4.000  
File : 98090106\_AREA.VLT  
Start : 1-Sep-98 11:18:40 am End : 1-Sep-98 11:29:38 am  
Motorola/swf3570a/vjxn3n0;836.49MHz;0.500 W;Helical/  
Head/Right Ear;AREA;034/E Field/0 DegreesBrain/41.000/0.850

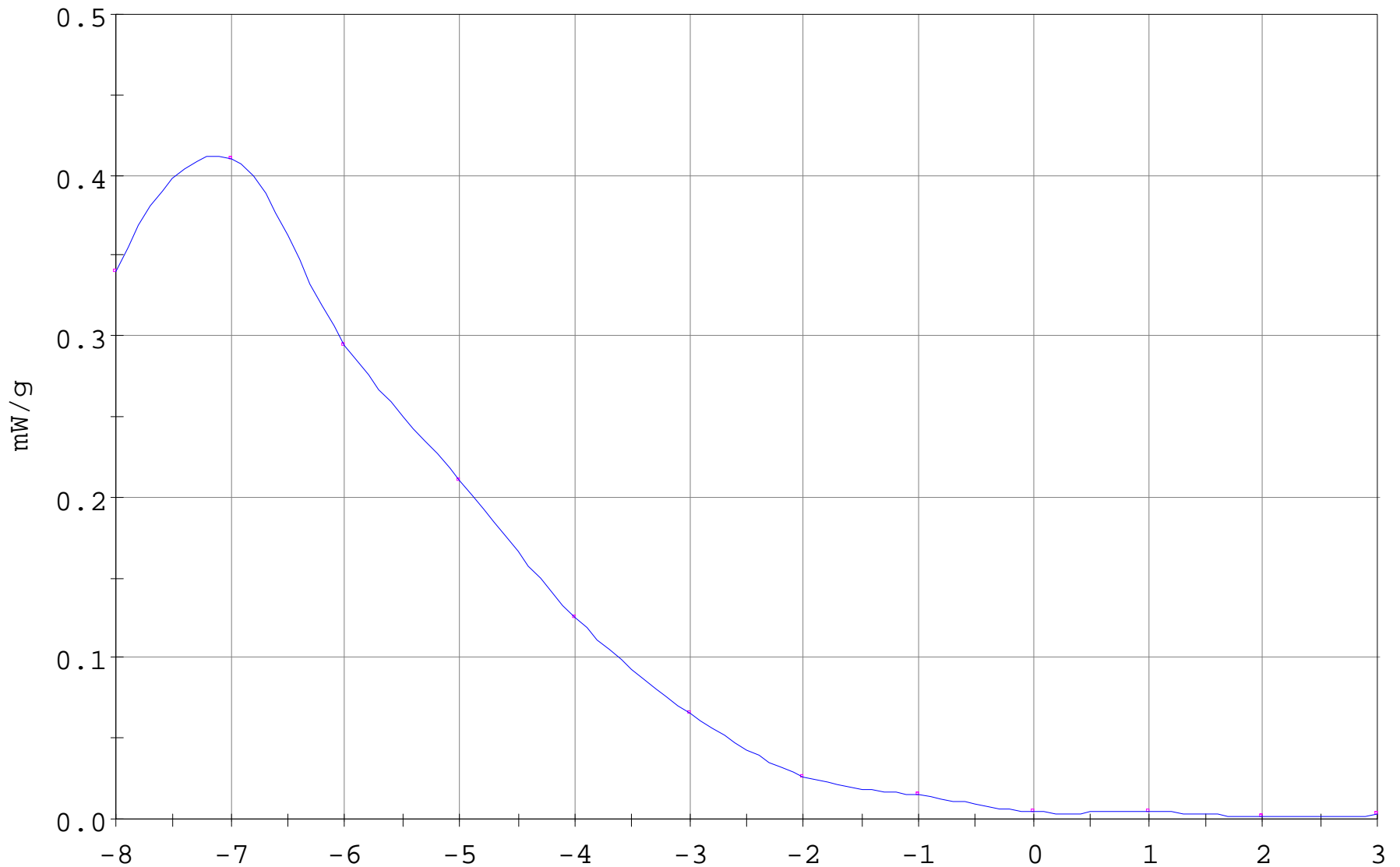

File : c:/idx3/SYSTEM/SARMEAS3/data/Normal/98090310\_ZOOM.VLT  
Start : 3-Sep-98 12:54:59 pm End : 3-Sep-98 01:00:04 pm

Radio Type : Motorola  
Model Number : swf3570a  
Serial Number : vjxn3no  
Frequency : 824.04 MHz  
Peak Trans. Pwr : 0.250 W  
Start Trans. Pwr : 0.250 W  
Antenna Type : End Fed  
Antenna Posn. : Out  
Phantom Type : Head  
Phantom Posn. : Left Ear  
Scan Type : ZOOM/SAR  
Probe Name : Probe036  
Field Type : E Field  
Orientation : 90 Degrees

Mixture Type = Brain  
Mixture Dielectric Constant = 40.000  
Mixture Conductivity = 0.850

Comment :  
digital/ch991/pwr1227/rd1.26/et

Robot : ROBOT 4

Probe Offset = 0.27 cm  
Sensor Factor = 0.0108  
Conversion Factor = 0.612

Probe036 Amplifier Channel Settings : 0.211 0.146 0.117

Max Location : X = -2.000, Y = 2.000, Z = 0.000 (cm) Value = 4.865

Measured Values (volts) =  
4.727E-003 2.854E-003 1.933E-003 1.418E-003 1.113E-003 1.017E-003  
8.529E-004 6.352E-004 4.407E-004 3.008E-004 3.097E-004

Calc. Voltage @ Surface (Vs) = 0.0060

Voltage @ 1.00 cm (Vt) = 0.0024

Ave. Voltage (Vs+Vt)/2 = 0.0042

Ave. SAR over 1 g (mW/g) = 0.2395

File : 98090310\_ZOOM.VLT

Start : 3-Sep-98 12:54:59 pm End : 3-Sep-98 01:00:04 pm

Motorola/swf3570a/vjxn3no;824.04MHz;0.250 W;End Fed/Out;

Head/Left Ear;ZOOM/SAR;Probe036/E Field/90 DegreesBrain/40.000/0.850

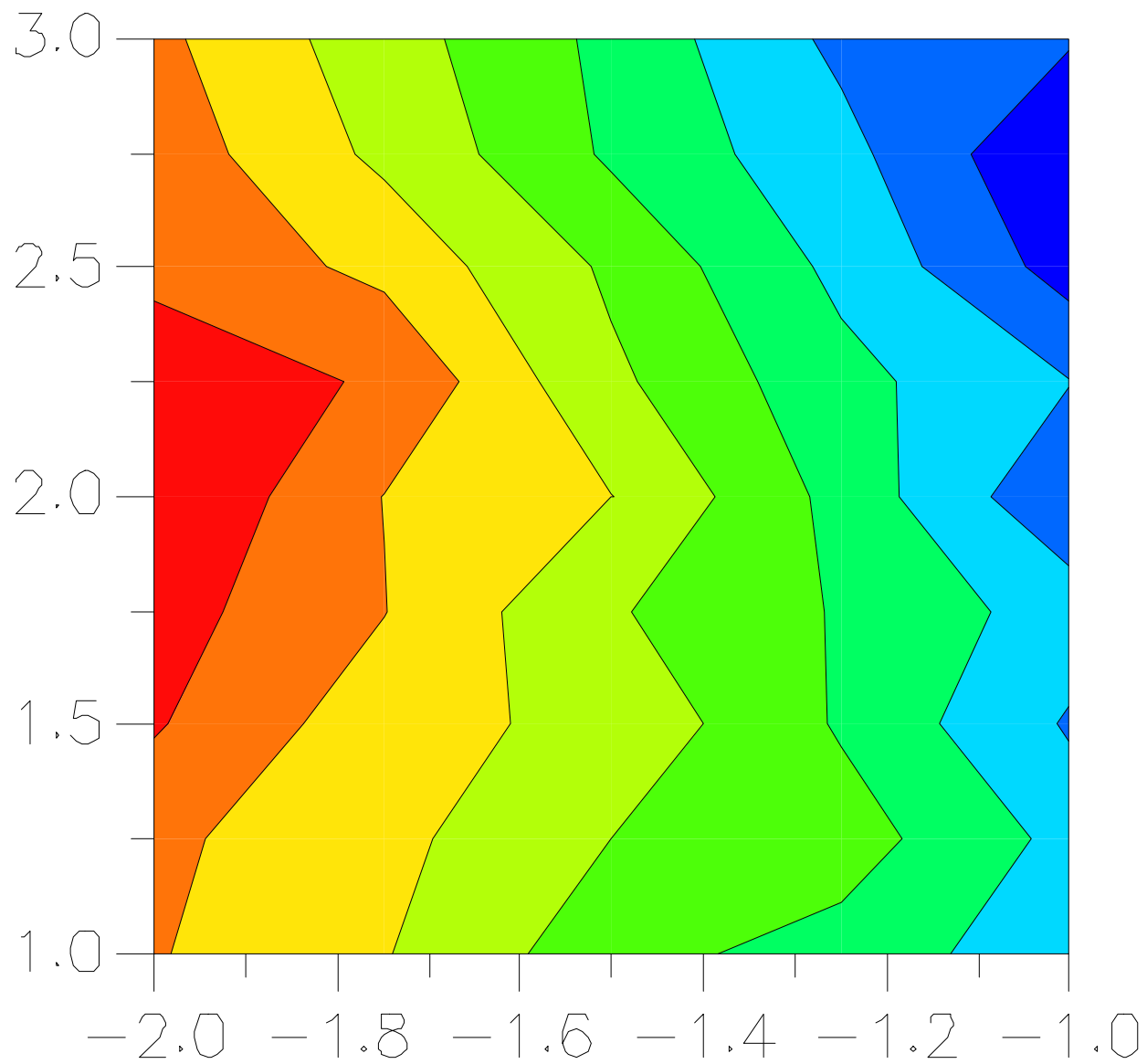

File : 98090310\_ZOOM.VLT

Start : 3-Sep-98 12:54:59 pm End : 3-Sep-98 01:00:04 pm

Motorola/swf3570a/vjxn3no;824.04MHz;0.250 W;End Fed/Out;

Head/Left Ear;ZOOM/SAR;Probe036/E Field/90 DegreesBrain/40.000/0.850

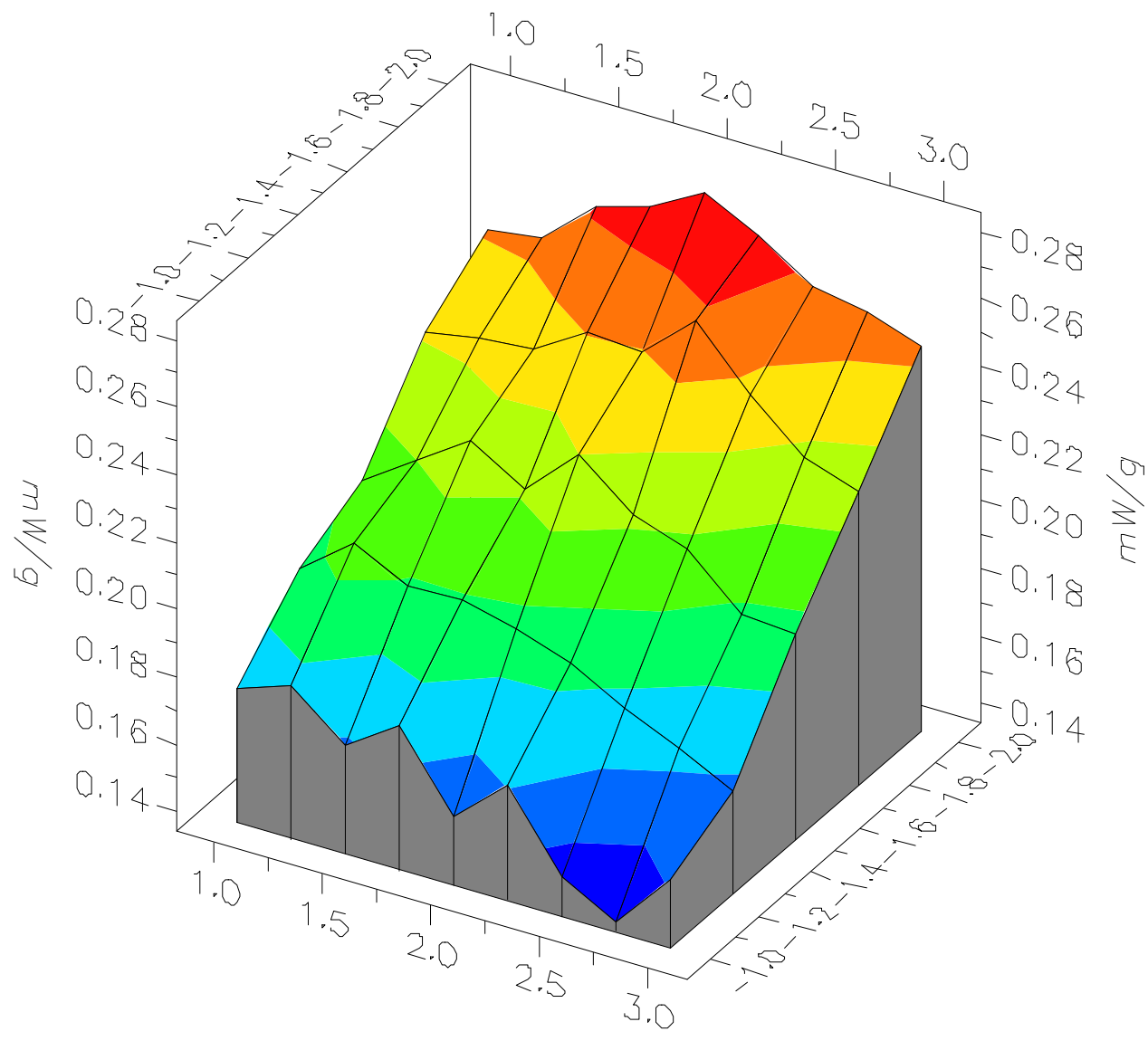

SAR Scan  
File : 98090310\_ZOOM.VLT  
Start : 3-Sep-98 12:54:59 pm End : 3-Sep-98 01:00:04 pm  
Motorola/swf3570a/vjxn3no;824.04MHz;0.250 W;End Fed/Out;  
Head/Left Ear;ZOOM/SAR;Probe036/E Field/90 DegreesBrain/40.000/0.850

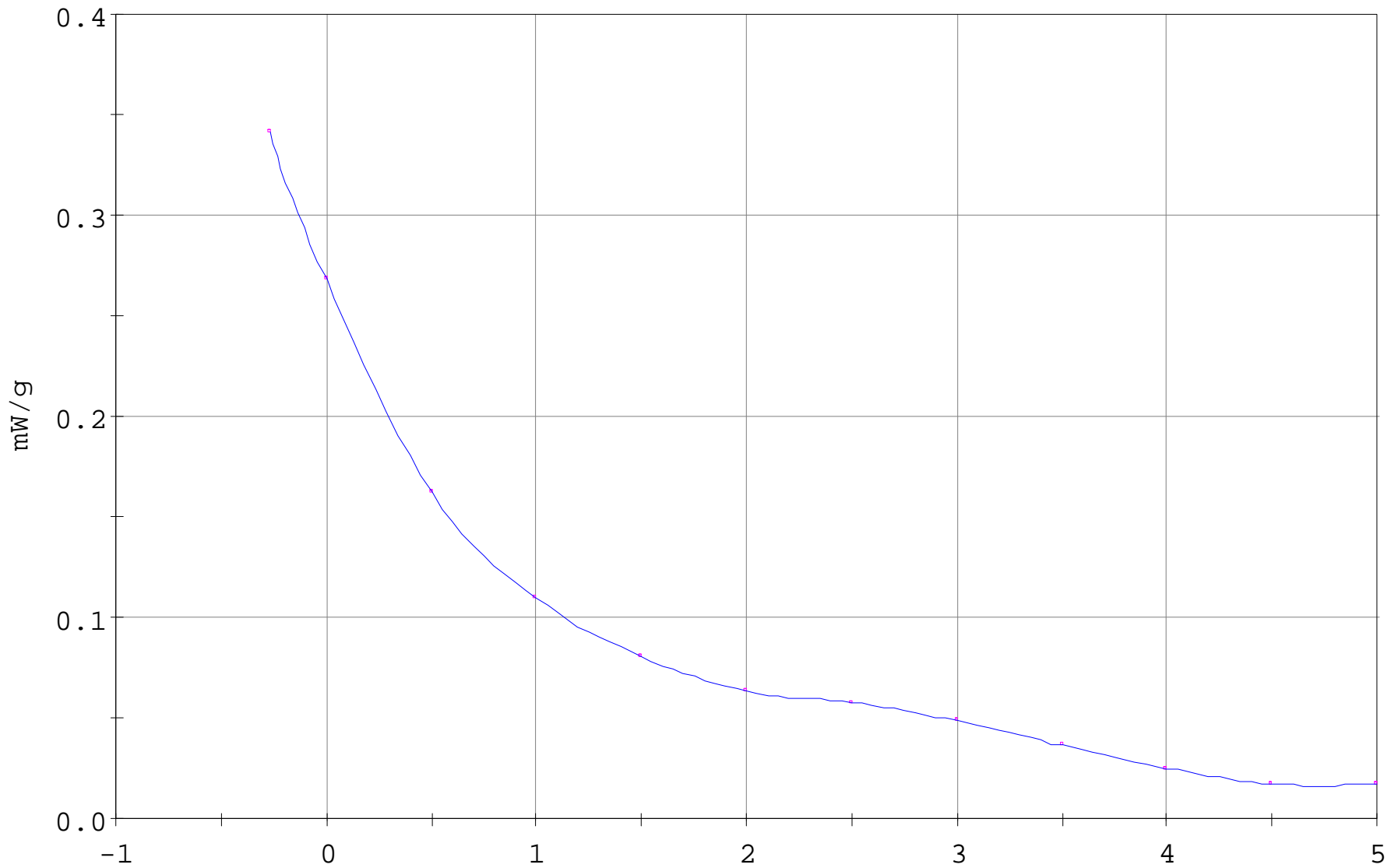

File : c:/idx3/SYSTEM/SARMEAS3/data/Normal/98090310\_AREA.VLT  
Start : 3-Sep-98 12:47:46 pm End : 3-Sep-98 12:54:58 pm

Radio Type : Motorola  
Model Number : swf3570a  
Serial Number : vjxn3no  
Frequency : 824.04 MHz  
Peak Trans. Pwr : 0.250 W  
Start Trans. Pwr : 0.250 W  
Antenna Type : End Fed  
Antenna Posn. : Out  
Phantom Type : Head  
Phantom Posn. : Left Ear  
Scan Type : AREA  
Probe Name : Probe036  
Field Type : E Field  
Orientation : 90 Degrees

Mixture Type = Brain  
Mixture Dielectric Constant = 40.000  
Mixture Conductivity = 0.850

Comment :  
digital/ch991/pwr1227/rd1.26/et

Robot : ROBOT 4

Probe Offset = 0.27 cm  
Sensor Factor = 0.0108  
Conversion Factor = 0.612

Probe036 Amplifier Channel Settings : 0.211 0.146 0.117

Max Location : X = -2.000, Y = 2.000, Z = 0.000 (cm) Value = 4.288

Area too wide. SAR value not calculated. Will be calculated on zoom scan.

File : 98090310\_AREA.VLT

Start : 3-Sep-98 12:47:46 pm End : 3-Sep-98 12:54:58 pm

Motorola/swf3570a/vjxn3no;824.04MHz;0.250 W;End Fed/Out;

Head/Left Ear;AREA;Probe036/E Field/90 DegreesBrain/40.000/0.850

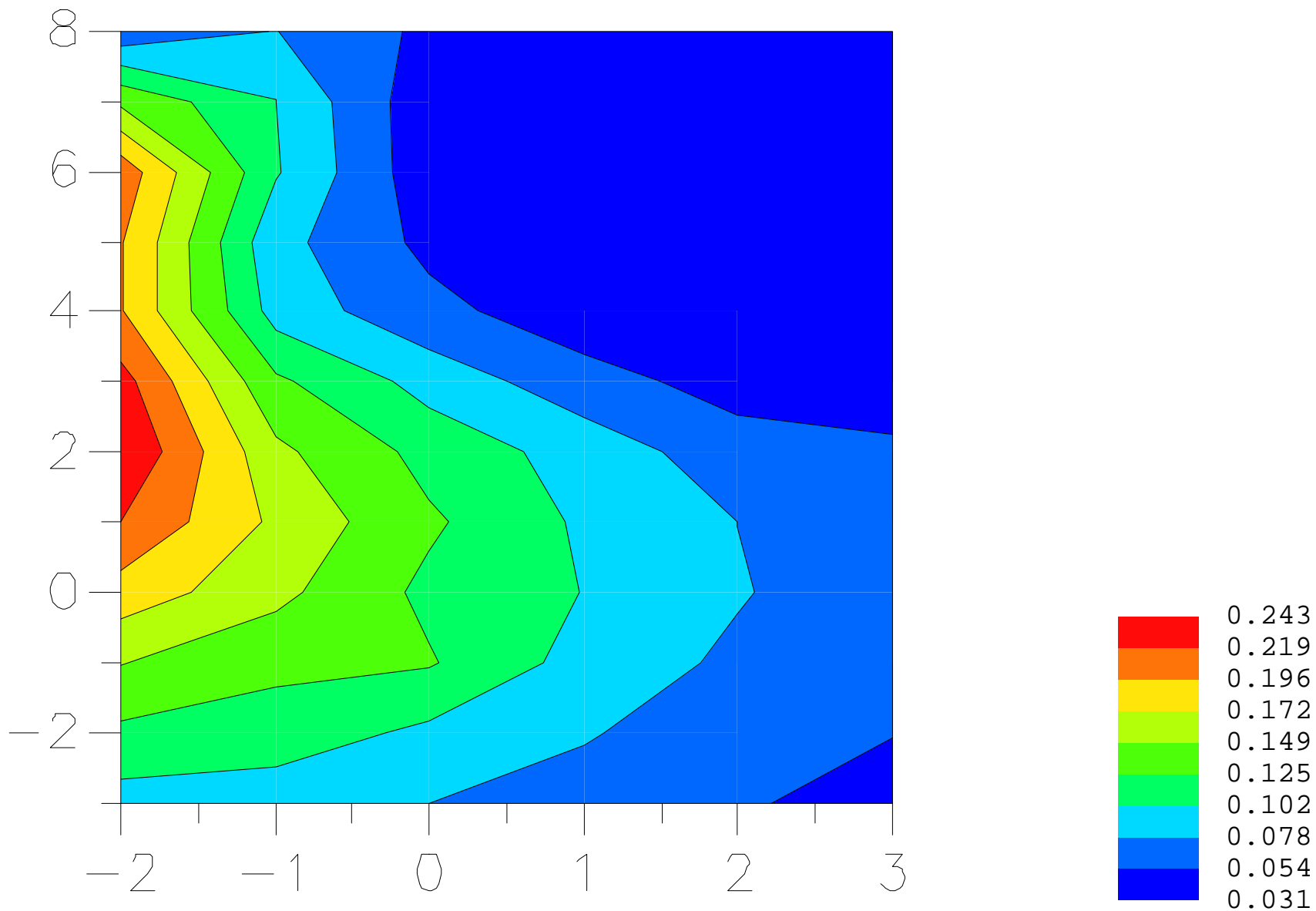

File : 98090310\_AREA.VLT

Start : 3-Sep-98 12:47:46 pm End : 3-Sep-98 12:54:58 pm

Motorola/swf3570a/vjxn3no;824.04MHz;0.250 W;End Fed/Out;

Head/Left Ear;AREA;Probe036/E Field/90 DegreesBrain/40.000/0.850

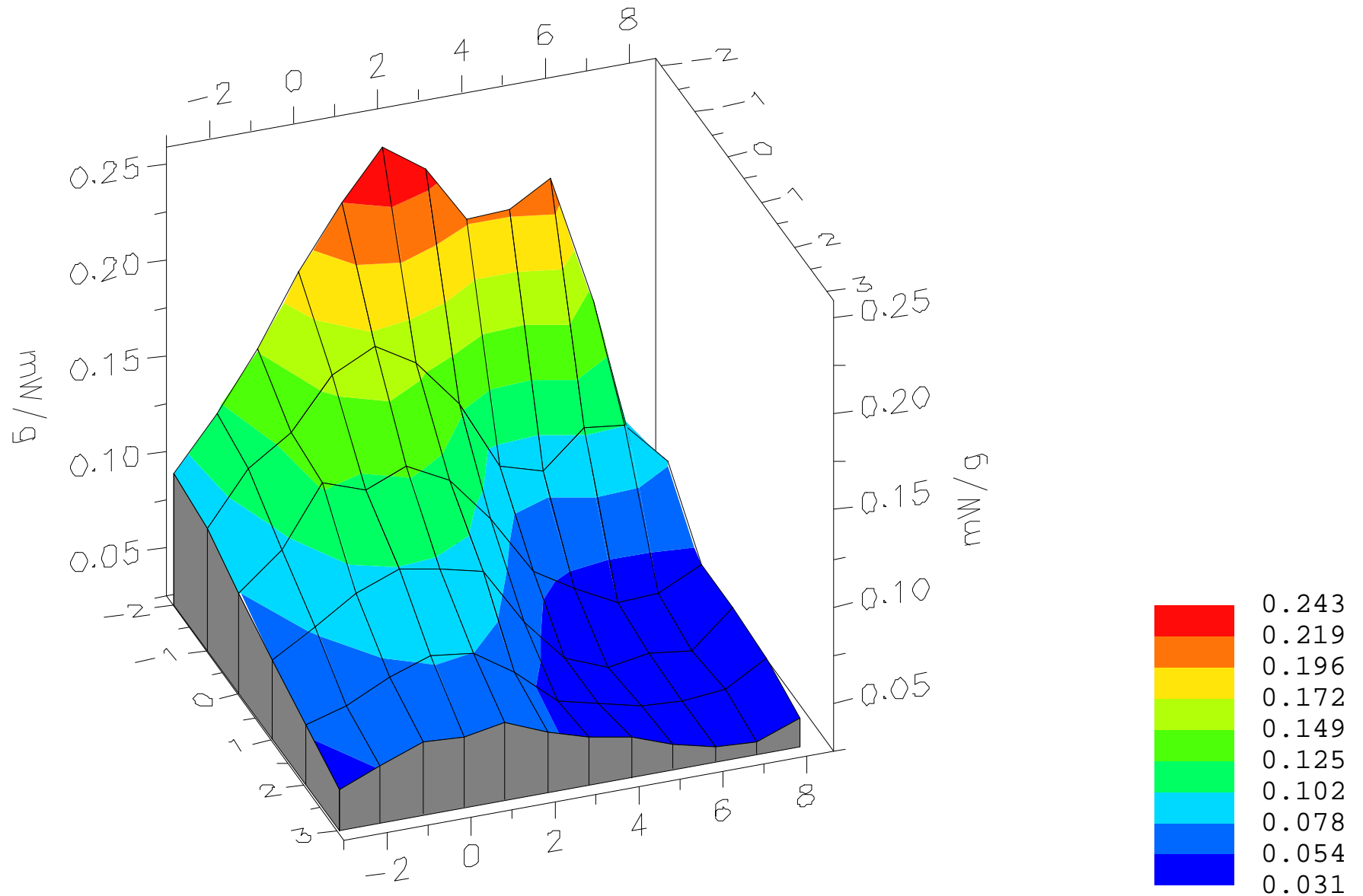

X-Z Plane Slice Y=2.000  
File : 98090310\_AREA.VLT  
Start : 3-Sep-98 12:47:46 pm End : 3-Sep-98 12:54:58 pm  
Motorola/swf3570a/vjxn3no;824.04MHz;0.250 W;End Fed/Out;  
Head/Left Ear;AREA;Probe036/E Field/90 DegreesBrain/40.000/0.850

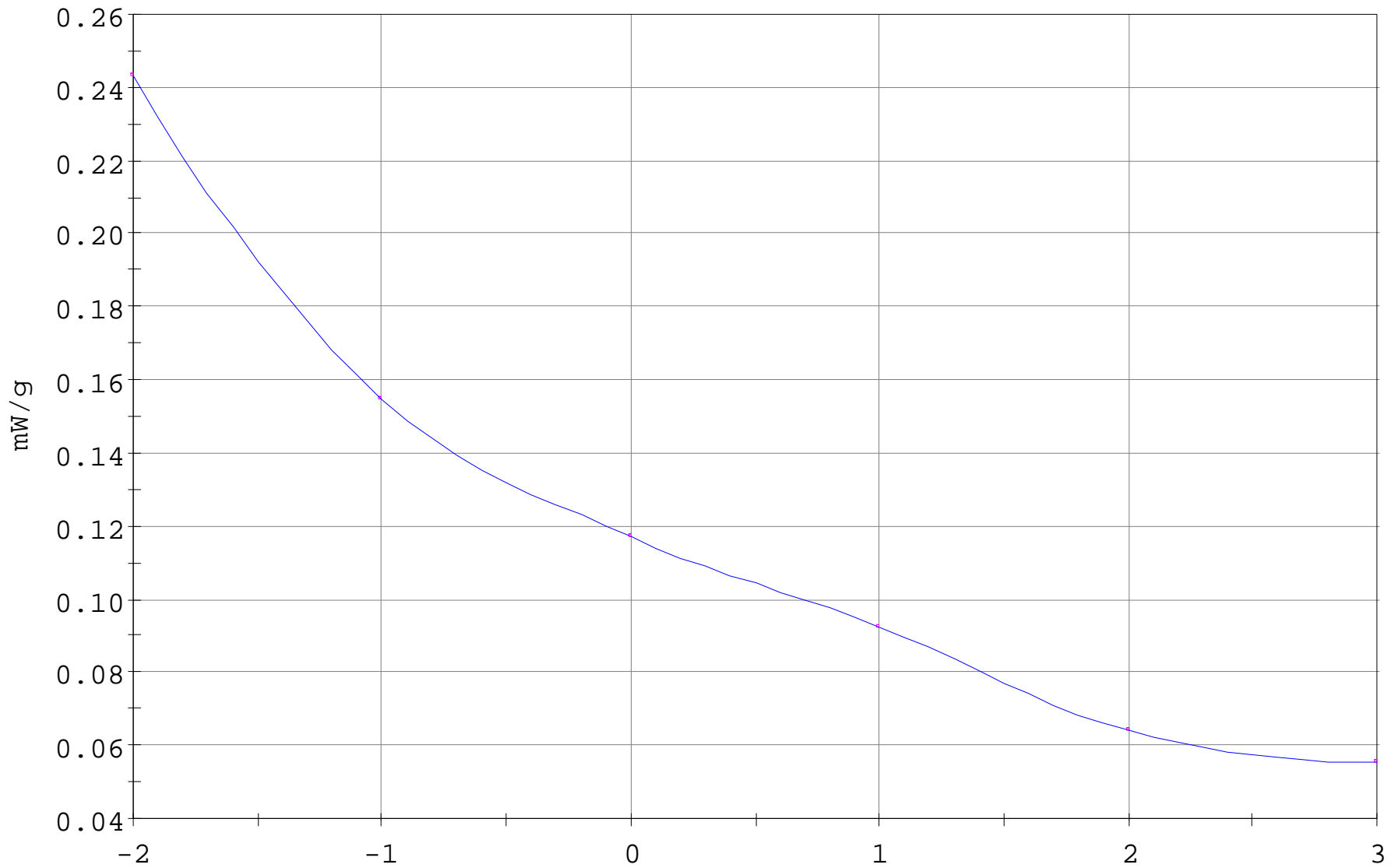

# SAR Measurement

## OPERATIONAL GUIDE



**FLORIDA CORPORATE ELECTROMAGNETICS  
RESEARCH LABORATORY**  
FORT LAUDERDALE, FLORIDA

- December 1997 -

# Table of Contents

## 1.0 Introduction

## 2.0 SAR Measurement System

- 2.1.0 E-Field Probe
  - 2.1.1 Isotropic E-field Probe
  - 2.1.2 Angular Response Outputs
- 2.2.0 Instrumentation Amplifier
  - 2.2.1 Views of Instrumentation Amplifier
  - 2.2.2 Diagram of Instrumentation Amplifier and Battery Supply
- 2.3.0 High Impedance Cables
- 2.4.0 Robotic Arm
  - 2.4.1 View of Robotic Arm
- 2.5.0 Arm Extension
  - 2.5.1 View of Arm Extension
- 2.6.0 Probe Holder
  - 2.6.1 Cross-section of Probe Holder
- 2.7.0 Computer System

## 3.0 SAR Measurement System Calibration

- 3.1.0 Determine E-field from Amplified Probe Outputs
  - 3.1.1 Method
    - 3.1.1.a Amplifier Setting Calibration Setup
  - 3.1.2 Measurement
- 3.2.0 SAR from Temperature Measurement and Correlation to E-field Probe
  - 3.2.1 Measurement
    - 3.2.1.a Flat Phantom, Thermistor and E-Probe
    - 3.2.1.b Correlation of E-field and Temperature Measurements
    - 3.2.1.c Field Attenuation in Simulated Tissue
  - 3.2.2 Determination of SAR Conversion Factor

## 4.0 Data Acquisition Methodology

- 4.1.0 E-field Measurement
- 4.2.0 SAR Measurement
- 4.3.0 Data Extrapolation
- 4.4.0 Data Interpolation and Gram Averaging

## Table of Contents continued

### 5.0 Phantoms

#### 5.1.0 Phantom Shells

#### 5.2.0 Simulated Tissue

##### 5.2.1 Preparation

###### 5.2.1.a Simulated Tissue Ingredients

##### 5.2.2 Electrical Characteristics Measurement

###### 5.2.2.a Equipment Used for Electrical Characteristics Measurement

###### 5.2.2.b Simulated Tissue Electrical Characteristics: Measured Data

###### 5.2.2.c Simulated Tissue Electrical Characteristics: Plotted Data

###### 5.2.2.d Dielectric Constant and Conductivity at Several Frequencies

##### 5.2.3 Determining Relative Dielectric Constant and Effective Conductivity

###### 5.2.3.a Table Comparing Mixture Analysis Methods

#### 5.3.0 Determining the Heat Capacity of Simulated Tissue

##### 5.3.1 Instruments and Materials

##### 5.3.2 Method

##### 5.3.3 Rationale

### *Appendix*

#### *A. Wire Stripper*

##### *A.1 Wire Stripper Design*

#### *B. Cable Construction*

##### *B.1 Details of High-impedance Cable Construction*

#### *C. Definition Amplifier Setting and Other Terms*

#### *D. Units and Various Calibration Factors*

#### *E. Derivation of Extrapolation Method*

#### *F. Complex Permittivity Measurements*

##### *F.1 Rigorous Method*

#### *G. Error Analysis (in preparation)*

*Note: This manual is intended as a supplement to the complete training course in SAR measurement given to Motorola personnel responsible for SAR evaluations. Although every effort has been made to be factually correct, the suitable application of the instruments and techniques described in this manual require hands-on training and practice.*

*This report was compiled from materials written and developed by the staff of the Florida Corporate Electromagnetics Research Laboratory. The principal authors are Oscar M. Garay and Quirino Balzano. Important contributions were provided by the entire AC497 team. Asher Sheppard (Asher Sheppard Consulting, Redlands, CA) assisted materially with editorial and technical matters. The authors gratefully acknowledge the excellent secretarial and graphic arts support from Esther Scott.*

# FLORIDA CORPORATE ELECTRONICS RESEARCH LABORATORY

## 1.0 Introduction

The increasing popularity of mobile phones and radios has been accompanied by a growing concern for possible health effects from radio frequency (RF) emissions of these and other transmitting devices. There is special interest in hand-held units where the radiating antenna is in close proximity to the user's head or body. It is unavoidable that some RF energy is absorbed by the user, usually by the parts of the body closest to the antenna. The requirement for accurate quantification of electromagnetic fields inside the body of a user of these devices has grown during the last few years.

When a radio wave at the frequencies used for wireless communications encounters a person, some of the wave is reflected; only a portion will enter the body. The precise proportions of absorbed, reflected and transmitted energies depend on the frequency of the wave and the electrical characteristics of the biological tissue. Research regarding the biological effects of radio and microwave radiation has been in progress for several decades and there are a large number of published studies. The only well understood and widely accepted effect of RF exposure of biological tissue at VHF and UHF is heating.

Radio frequency electromagnetic dosimetry is the quantification of the magnitudes and distribution of absorbed energy within biological objects that are exposed to RF radiation. Dosimetry for RF is significantly more complex than for radiation of much higher frequencies, such as infrared, light, ultraviolet, and ionizing radiation. It is usually sufficient to characterize the intensity of the external exposure wave in terms of dose or dose rate. At radio frequencies the dosimetric quantity, Specific Absorption Rate (SAR), is defined as the rate at which energy is absorbed per unit of mass per unit of time (e.g. in units of W/kg). The SAR is determined not only by the characteristics of the external electromagnetic waves, but also the electrical and geometric characteristics of the exposed subject. SAR distributions are usually measured in human models or animal tissues, or are determined mathematically. Two methods are available:

(1) Electric field measurement. Because the SAR is related to the internal electric field strength (E) as well as the electric conductivity and the mass density of tissues, it can be measured by small E-field probes.

(2) Temperature measurement. The initial rate of temperature rise in an exposed object is a function of SAR so that implantable RF-transparent temperature probes also may be used to measure localized SARs.

The definition of Specific Absorption Rate is the time derivative of the incremental energy (dW) absorbed by (dissipated in) an incremental mass (dm) contained in a volume element (dV) of given density (  $\rho$  ):

$$\text{SAR} = \frac{d}{dt} \frac{dW}{dm} = \frac{d}{dt} \frac{dW}{dV} \cdot \rho$$

The SAR induced in RF-exposed tissue can be calculated from the relationship:

$$\text{SAR} = \frac{|E|^2}{\rho}$$

where E is the total RMS E-field level (V/m) induced within the exposed tissue,  $\sigma$  is the conductivity (S/m), and  $\rho$  is the tissue density (kg/m<sup>3</sup>).

The brain, because of its critical control functions, has been of interest in microwave effects research. The distribution of RF energy absorption in an irregular inhomogeneous structure such as a human head is complex and very difficult to predict. Electromagnetic field phenomena such as whole body resonance, layered resonance, skin depth and reflections at dielectric interfaces all contribute to the makeup of the induced field pattern.

Because of the invasive nature of E-field probes, measurement of induced E-fields is not possible in living human subjects; surrogate phantoms of the human body must be used. Because the distribution of induced E-fields depends critically on body size, shape and orientation, animal studies do not give direct evidence for human exposures.

Safe exposure to RF fields is established by various international standards (for example ANSI/IEEE C95.1-1992 in the U.S.A.). Generally, these standards prescribe electric and magnetic field exposure limits over the frequency spectrum. Motorola requires dosimetric measurements for Safety Compliance in the Ship Acceptance process. This Operational Manual will describe the methodology used to fulfill the requirement of Specific Absorption Rate Measurement.

The SAR Automated Measurement System is based on a highly accurate computer-controlled robotic arm with positioning repeatability of 0.1 mm. The arm is used to position a highly sensitive E-field probe inside a human-shaped phantom filled with a liquid having the complex electrical characteristics of human brain or muscle tissue. The probe has an isotropic response and causes minimal field disturbance (RF transparency). This system satisfies the accuracy, reliability, and efficiency demands of today's desired level of quality.

**Note:** Numeric values which appear in menus and sample data in this manual are for illustration purposes only.

## 2.0 SAR Measurement System

The SAR Measurement System consists of an E-field probe, differential amplifiers, high impedance cables connecting the probes to the differential amplifiers and the amplifier outputs to a computer, the robotic arm with its extension, a custom probe holder, simulated tissue phantom, and a holder assembly for the device under test.

### 2.1.0 E-Field Probe

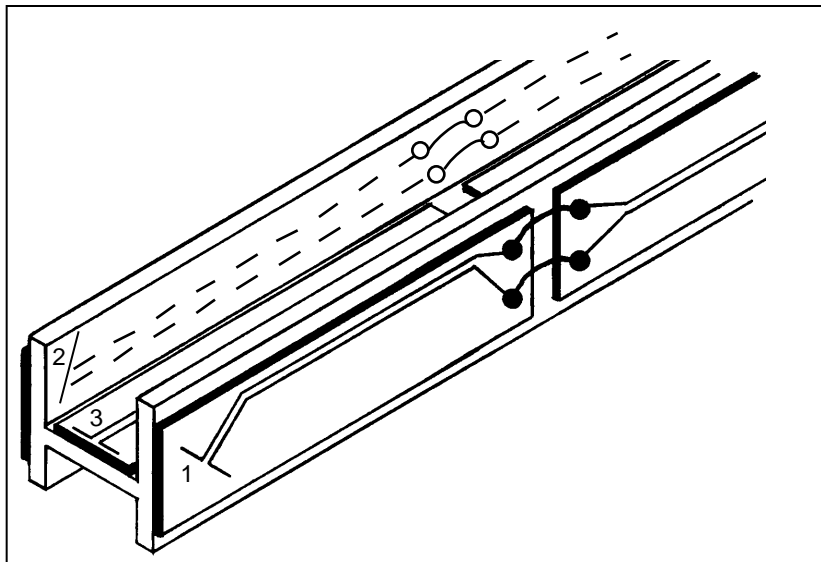

*Fig. 2.1.1 - Isotropic E-field probe showing location of 3 dipoles on quartz substrates attached to a non-metallic I-beam support.*

The E-field probe (Fig.2.1.1) is a three-channel device used to measure RF electric fields. The sensors are three mutually-orthogonal dipoles, each 2.5 mm in length. For each channel of the probe, the dipole and two high-impedance lines are vapor-deposited on a quartz substrate. Located at the center of the dipole is a Schottky diode (not shown in Fig. 2.1.1). The three substrates are mounted on a non-conductive RF-transparent support which has an I-beam cross-section. Along the support are three pairs of high impedance lines which connect the substrates to a single output connector. The probe is enclosed in a protective sleeve to avoid contact with the corrosive elements of the simulated tissue. The total length of the probe is approximately 25 cm. The probe does not perturb significantly the field being measured. It is isotropic; that is, no matter how the probe is positioned physically relative to the E-field, the sum of the outputs of the three channels always gives the same value. The probe is very fragile, can be damaged by mechanical shock, and should be safely stored when not in use.

The following plots show the output of an E-field probe versus angular position for rotation in a vertical plane in a TEM cell in both rectangular and polar presentations.

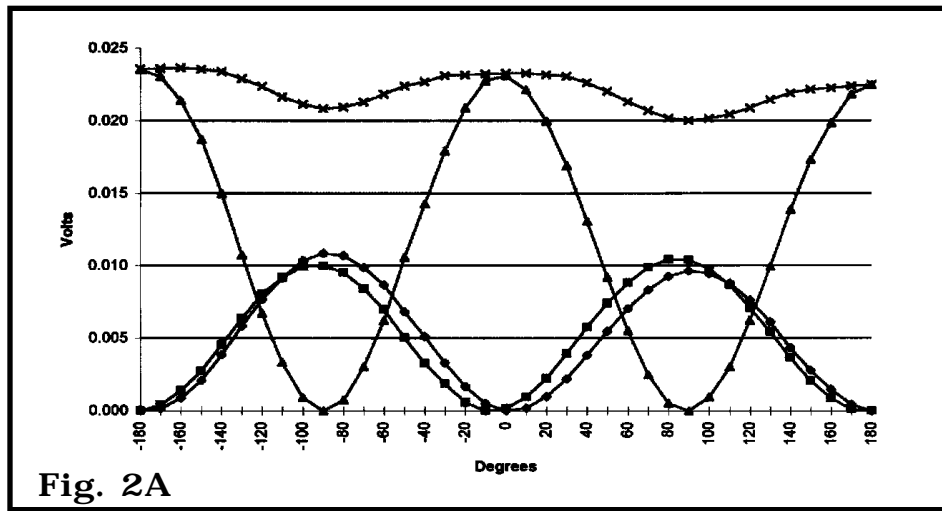

**Fig. 2A**

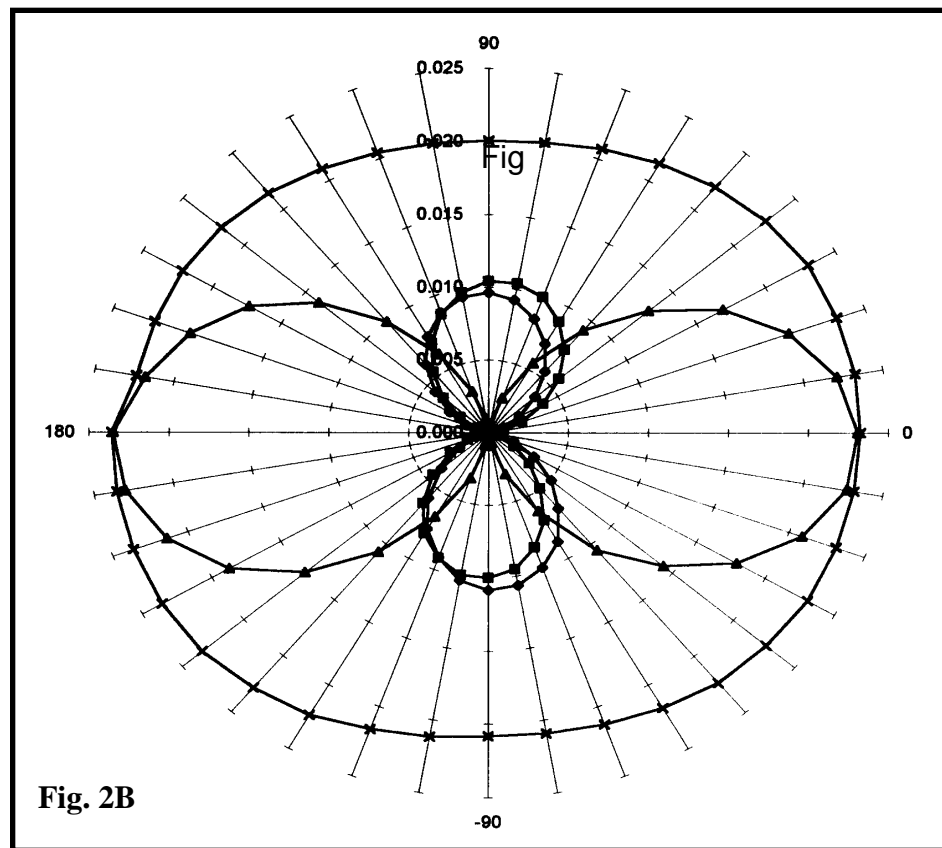

**Fig. 2B**

*Fig. 2.1.2 -Angular response outputs of individual dipoles and summed output of isotropic E-field probe from TEM cell test. The voltage from probe Channel 1 is indicated by a diamond, Channel 2 by a square, Channel 3 by a triangle, and the sum of the three channels by an X. The probe was rotated about its own axis with zero degrees defined by alignment of the no. 3 dipole with the electric field direction. The tip of the probe was located at the volumetric center of the space between the septum and the outer wall of a TEM cell.*

## 2.2.0 Instrumentation Amplifier

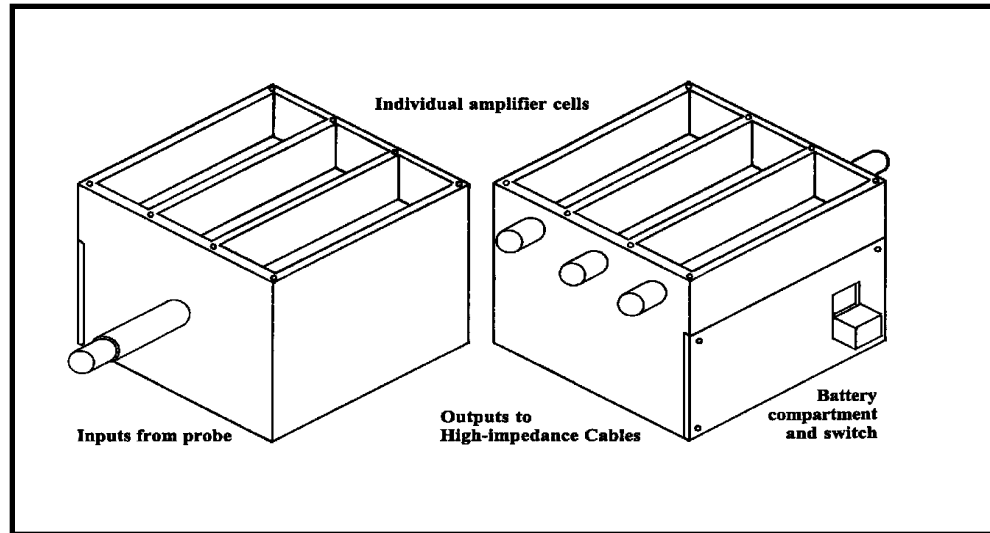

*Fig. 2.2.1 -Instrumentation Amplifier. Metallic housing for DC amplifiers*

In the instrumentation amplifier, the signal from each channel of the E-field probe is connected independently to its own differential amplifier which has a voltage gain of approximately 20. The differential output of each amplifier is fed to its own output connector. The three identical DC amplifiers (Fig. 2.2.2) are located in individual cells in the solid brass housing (Fig. 2.2.1). The three channels are therefore highly isolated from each other and shielded from outside interference. A two-battery power supply, voltage regulator, and switch also reside inside the housing.

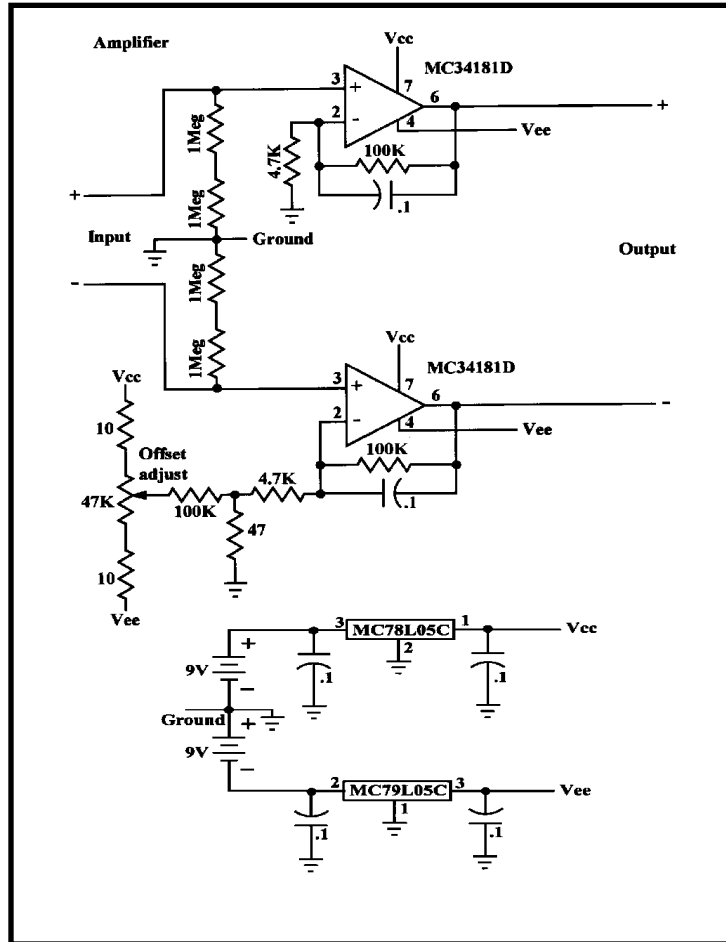

Fig. 2.2.2 -Diagram of Instrumentation Amplifier (top) and battery supply (bottom)

### 2.3.0 High-impedance Cables

The high-impedance cables which connect the outputs of the instrumentation amplifier to the voltmeters are made of carbon-impregnated fiber. They will not respond significantly to RF electromagnetic fields, but will allow passage of the DC currents from the probe. The cables have an impedance of 3-4 kilohms per foot. Each amplifier channel is connected independently to its own voltmeter via two high-impedance cables to the computer. See Appendices A and B for details of cable construction and a custom wire stripper.

## 2.4 Robotic Arm

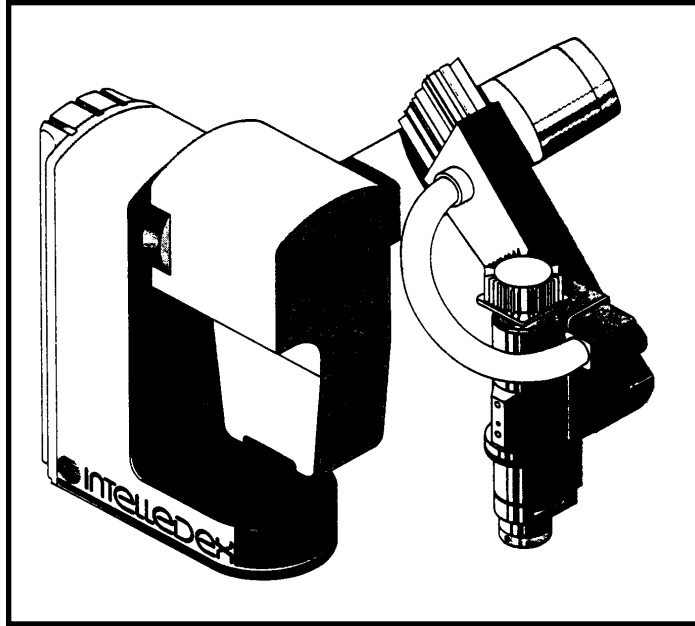

Fig. 2.4.1 -View of Robotic Arm

The probe is moved to the various measurement points by an Intellex Microsmooth Model 660 6-axis robotic arm. The robot command language is Intellex Robot Basic, a superset of Microsoft Basic. Communication with the robot is by a push-button (“joystick”) handheld controller and over an RS-232 link as commanded by IDX custom software.

## 2.5 Arm Extension

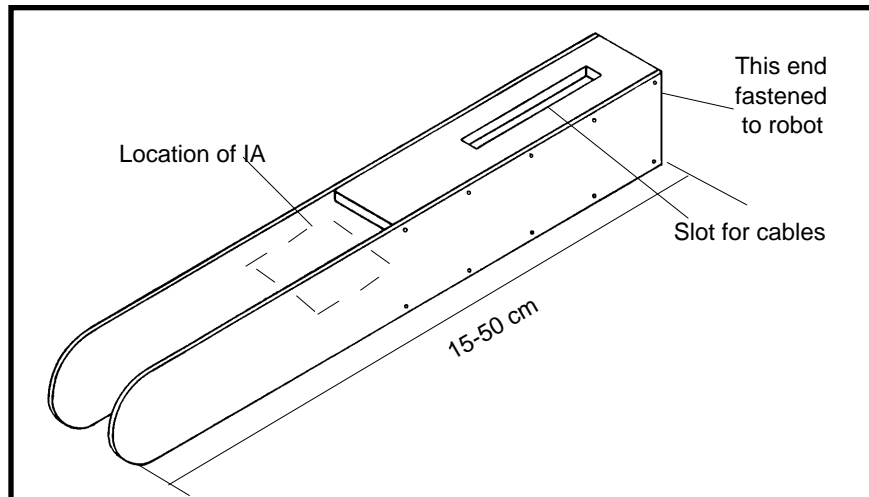
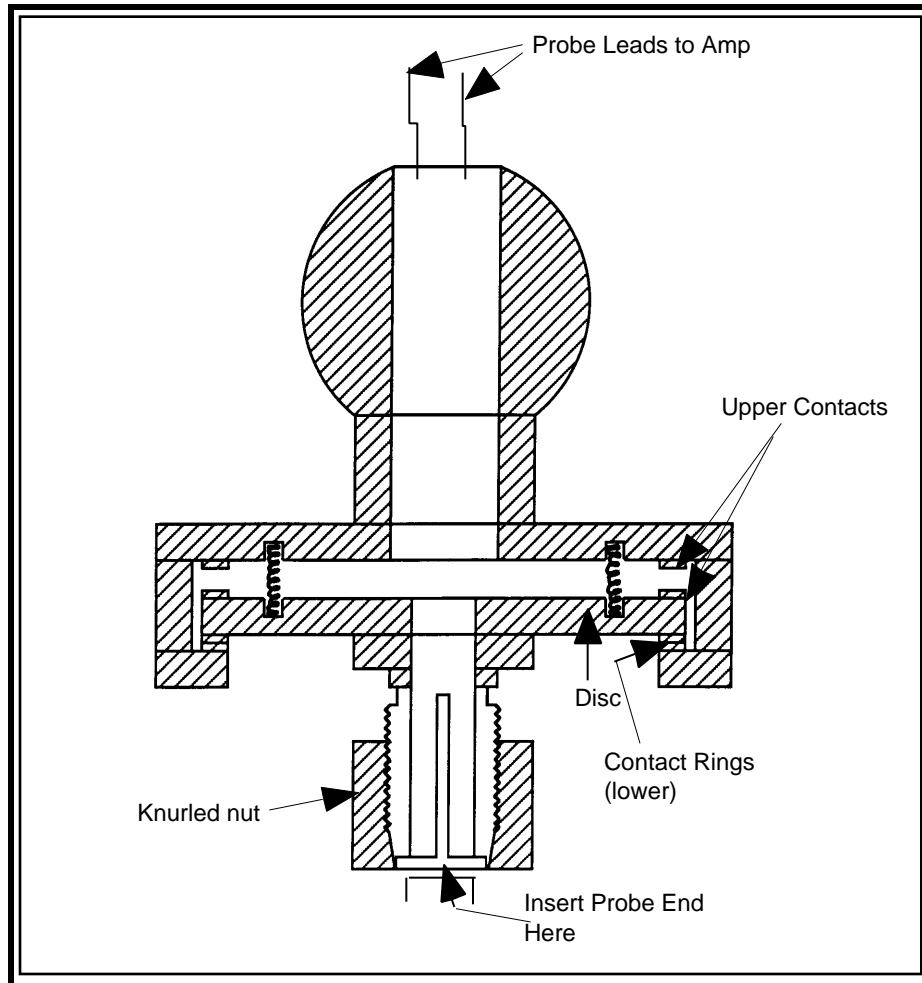

Fig. 2.5.1 -View of Arm Extension

Attached to the end of the robot arm is an extension, constructed of plastic to avoid interference with the electromagnetic fields being measured. Inside the arm extension is a passageway for the high-impedance cables and a support to hold the instrumentation amplifier (IA) (See Fig. 2.5.1).

### 2.6.0. Probe Holder



*Fig. 2.6.1 -Cross Section of Probe Holder and view of proximity sensor contacts*

The probe holder is made of plastic to avoid perturbing the electromagnetic fields. It is attached to the arm extension via a ball joint which enables the probe to be easily adjusted to the proper angle relative to the device being measured.

The clamp which holds the probe is split into four sections which are tightened against the probe by a knurled nut. It is mounted on a disc which is not rigidly attached to the rest of the probe holder but is held in place by several helical springs.

Mounted on the outer edge of the top and bottom surfaces of the disc are metal contact rings which correspond to similar contacts on the non-moving portion of the probe holder and serve as proximity switches. The lower contacts, one a solid ring and the other, segmented, are held together (normally closed) by the springs.

For dosimetric studies, at every (x,y) coordinate in the grid, determined by the 3 teach points, the z coordinate of the measurement point must be determined. This is achieved by detecting the contact of the probe with the inner surface of the phantom using the proximity switches. The probe is moved in the -z direction until it contacts the surface and at least one segment of the lower contacts located in the proximity switch open. The direction is then reversed until the moment all contacts close. This is the position where the E-field measurement is taken. This signals the location of the phantom to the software. The upper contacts, both solid rings, are normally open. They are connected via a relay to the Emergency Stop circuit of the robotic arm. If the probe strikes something during a measurement, the contacts close, the relay opens, and the robot immediately stops moving.

## **2.7 Computer System**

The FEL Automated Measurement System is integrated as follows:

### **System Controller**

- IDX Robotics General Purpose End Effector Card
- IDX Robotics 256K CMOS RAM Board
- Micron 75 MHz Pentium with 16 MB Ram
- Microsoft Windows NT Workstation Version 3.51
- IDX Robotics Flexware Software Package
- IDX SAR Measurement System Configuration
- National Instruments Lab PC+ Data Acquisition Card
- National Instruments NIDAQ Device Drivers for Win<sup>NT</sup>

Hard copy output device: any compatible printer.

### 3.0 SAR Measurement System Calibration

The SAR measurement system has two main components: a) the probe, which is connected to the inputs of b) the instrumentation amplifier whose outputs are connected through high-impedance cables to c) the computer. The system is calibrated as one unit, not as individual components. If any component is modified or replaced, the system must be re-calibrated.

The system calibration is performed by two steps: 1) determination of free space E-field from amplified probe outputs in a test RF field, and 2) correlation of the measured free space E-field and the measured E-field in the medium to temperature rise in a dielectric medium.

#### 3.1.0 Determine E-field from Amplified Probe Outputs

**Note: Equipment must be regularly calibrated.**

*Warning! Observe manufacturer's recommended warmup time.*

- RF Signal Generator - frequency range to at least 2 GHz
- RF Amplifier - if needed to generate the required power density in the test cell
- Test cell - TEM (Crawford) Cell, waveguide, or other device capable of maintaining a uniform field
- RF Power Meter - capable of measuring at least 5 Watts (current calibration is mandatory!) and traceable to the National Institute of Standards and Technology (NIST).
- E-field probe
- Probe support fixture
- Instrumentation amplifier
- High-impedance cables
- Computer program with the automated calibration system program

#### 3.1.1 Method

However, due to impedance variations in the diodes and the high-impedance lines and cables, and slight differences in gain between the channels of the instrumentation amplifier, there are imbalances that must be compensated.

The calibration method actually used is to determine the factors necessary to adjust each channel of the system so its indicated output can then be equated to the RF field. These factors are referred to as "amplifier settings."

Because of the geometry of the probe elements, if the probe axis is aligned perpendicular to the E-field, the output of Channel 1 should equal that of Channel 2 when the probe is rotated so that the Channel 1 and Channel 2 dipoles are in the plane of and at 45° to the E-field. In this orientation the sum of the outputs of Channels 1 and 2 should equal the output of Channel 3 when the Channel 3 dipole is parallel to the E-field. (See Fig. 2.1.2)

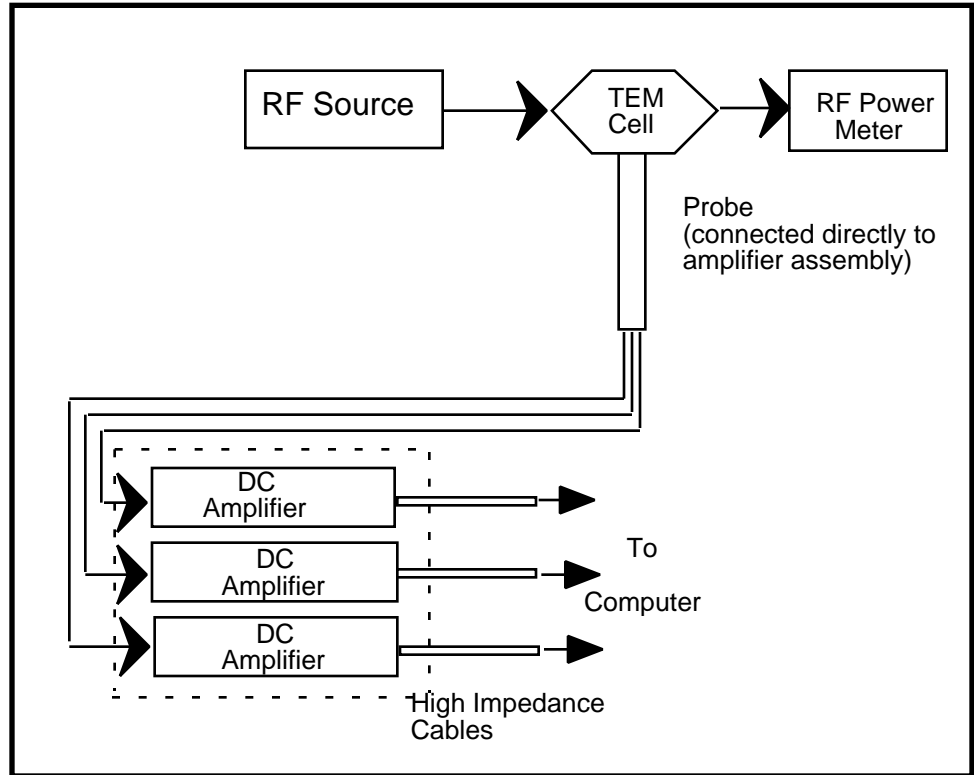

Fig. 3.1.1.a -Amplifier Setting Calibration Setup

### 3.1.2 Measurement

Free space calibration of E-field probes can be performed using a TEM cell manufactured by IFI (Instrumentation for Industry, Farmingdale, NY 11735) with operating frequency at or below 1 GHz.

- Connect the equipment as shown above.
- Adjust the RF generator output so that the power density inside the TEM Cell is  $1\text{mW}/\text{cm}^2$ . (For the IFI Model CC-110 Cell, the correct power level is 271 mW.)
- Mount the probe of the system to be calibrated in the support fixture. Insert the probe through the side aperture of the TEM Cell. The probe handle should be at the geometric center of the aperture, i.e., midway between the septum and the upper surface, and orthogonal to the side of the Cell. The sensing portion of the probe should be located at a point halfway across the depth of the cell (volumetric center).
- *Once the prescribed position is obtained, it **must** be maintained during the rest of the measurement. The **only** movement of the probe allowed is rotation on its axis to position the dipoles in the plane of E-field and, for channel 3 only, parallel to the vertical uniform field ( max./min. output).*
- Verify that the RF power level remains constant throughout the measurement. While the probe is being rotated through 360 degrees, software indicators will show the maximum measured on each channel.

Thus, the amplifier settings for each channel are as follows:

$$AS_1 = \frac{\frac{\text{Sensor Factor}}{2}}{V_{\max_1} - DC_1}$$

$$AS_2 = \frac{\frac{\text{Sensor Factor}}{2}}{V_{\max_2} - DC_2}$$

$$AS_3 = \frac{\text{Sensor Factor}}{V_{\max_3} - DC_3}$$

Where:

$AS_n$  = Amplifier Setting for Channel n

Sensor Factor = an arbitrary value  $\frac{10.8 \text{ mV}}{\text{mW/cm}^2}$

$V_{\max_n}$  = Maximum voltage recorded for channel n by rotation about the probe axis with the probe in a TEM Cell (E perpendicular to the probe axis)

$DC_n$  = DC-offset of channel n (the voltage out of the high-impedance cables with the instrumentation amplifier on and RF power off, recorded at the beginning of probe calibration)

## 3.2 SAR from Temperature Measurement and Correlation to E-field Probe

### 3.2.1 Measurement

An RF-transparent thermistor-based temperature probe (Vitek Electrothermia Monitor #101) and an isotropic E-field probe are placed side-by-side in a planar phantom while both are exposed to RF energy from a half wave dipole antenna located below the phantom (See Fig.3.2.1.a). The E-field probe and amplifiers were previously calibrated.

First, the location of the maximum E-field close to the phantom's bottom is determined as a function of power into the dipole (See Fig.3.2.1.a).

Then, the E-field probe is moved sideways so that the temperature probe, while affixed to the E-field probe, is placed at the previous location of the E-field probe.

Finally, temperature changes for 30 second exposures at the same RF power levels used for the E-field measurement are recorded. Care is taken to allow cooling to the original temperature and temperature stabilization between tests.

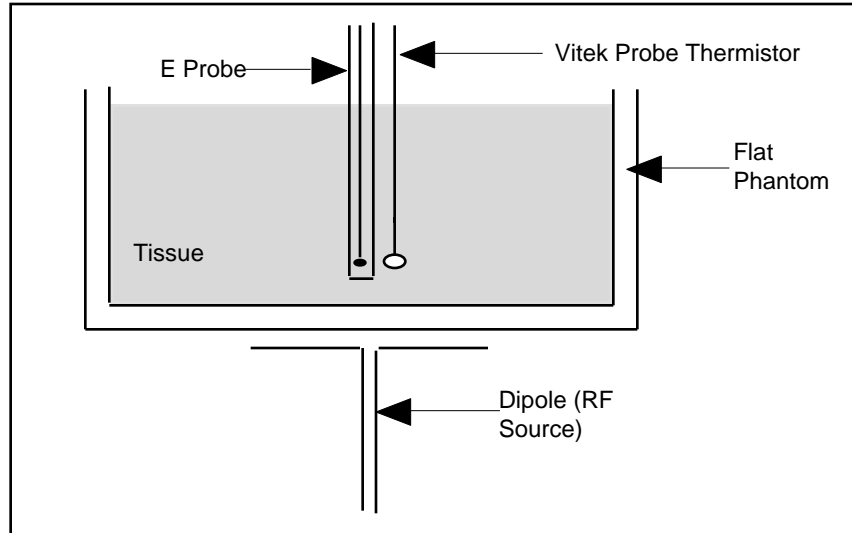

Fig. 3.2.1.a -Flat Phantom, Thermistor and E-Probe

The following simple equation relates SAR to the initial temperature slope:

$$SAR = \frac{1}{t} \cdot c \cdot \Delta T \quad (1)$$

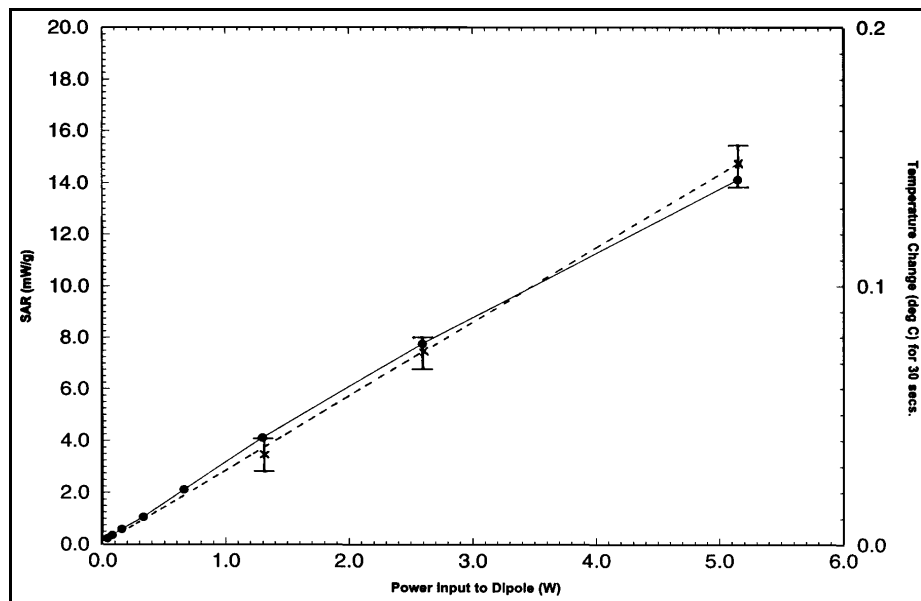

Fig. 3.2.1.b-Example of correlation of E-field and temperature measurements; the exposure time of the phantom for each of the plotted temperature measurements was 30 seconds

In (1)  $t$  is the exposure time (30 s),  $c$  is the heat capacity of the simulated brain tissue ( $c = 2.7$  joules/ $^{\circ}\text{C}/\text{g}$ ) and  $\Delta T$  is the temperature increase due to the RF exposure. SAR is proportional to  $\Delta T / t$ , the initial rate of tissue heating, before thermal diffusion takes place.

From (1) it is possible to quantify the electric field *in the simulated tissue* by equating the thermally-derived SAR to the E-field

$$\text{SAR} = \frac{\sigma |E|^2}{\rho} \quad (2)$$

where  $\sigma$  is the simulated tissue conductivity and  $\rho$  its density; (typically  $\rho = 1.25 \text{ g/cm}^3$  for simulated brain tissue).

Since, even at the closest practical position, the E-field sensors are at a distance ( $\approx 4 \text{ mm}$ ) from the surface of the phantom shell, the field in the simulated tissue near the shell surface must be calculated. To do so, data are obtained as the probe is moved vertically, from the surface of the planar phantom.

The field attenuation is recorded and extrapolated to obtain the  $|E|^2$  value at the surface of the phantom, where the maximum SAR is located. This method has given highly repeatable results. Figure 3.2.1.c shows the measured data and the result of the extrapolation (the method is described in the next section).

The errors affecting the inter-calibration of SAR by E-field and temperature methods are well within acceptable limits.

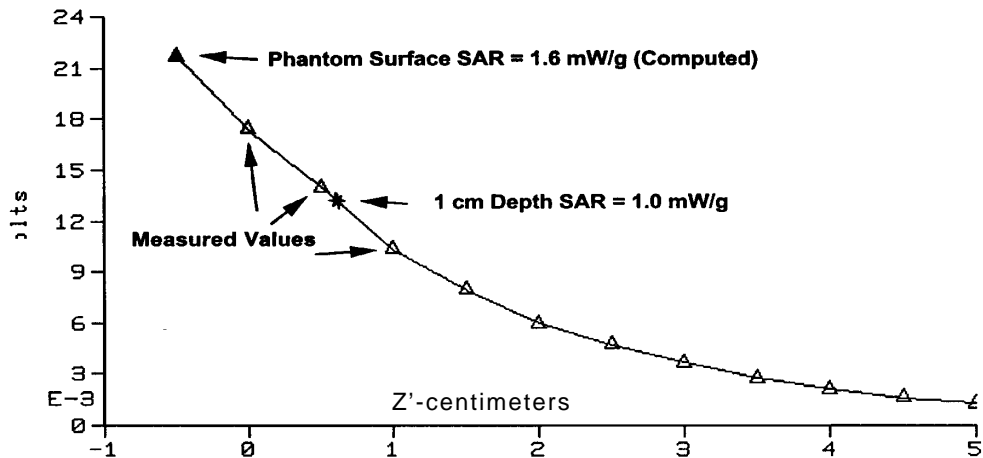

Fig. 3.2.1.c -Field attenuation in simulated tissue and result of data extrapolation. Note the surface is at  $Z' = -0.4 \text{ cm}$  and the position 1 cm from the surface is at  $Z' = 0.6 \text{ cm}$ .

### 3.2.2 Determination of SAR Conversion Factor (CF)

The “conversion factor” scales the E-field in terms of the thermally-derived SAR. It is the quotient of SAR<sub>t</sub>, the SAR determined from temperature measurements in the flat phantom, and V<sub>t</sub>, the E-field probe output voltage obtained at the same location in the phantom (see Sec. 3.2.0)

$$CF [mW/g] = \frac{SAR_t}{V_t} \times 0.0108, ( V_t \text{ in V } ) \text{ or,}$$

$$CF [mW/g] = \frac{SAR_t}{V_t} \times 10.8, ( V_t \text{ in mV } ).$$

For historical reasons, CF is scaled by the factor 10.8 mV. (See the discussion of Sensor Factor in Appendix D). Note, as a result of the scaling constant (10.8mV) the dimensions of CF are [mW/g].

The temperature-E-field correlation is illustrated below (for simulated brain tissue) for an example in which the thermal quantities were,

$$\begin{aligned} \text{RF power input} &= 0.5 \text{ W,} \\ T &= 0.0163^\circ \text{ C (from Vitek thermistor probe),} \\ c &= 2.7 \text{ J/g}^\circ \text{ C (simulated brain tissue), and} \\ t &= 30 \text{ s.} \end{aligned}$$

The resulting SAR<sub>t</sub> was (e.q. [1]),

$$SAR_t = ( 2.7 \times 0.0163 ) / 30 = 1.47 \text{ mW/g}$$

In this case the output of the E-field probe when at the same position as the thermistor probe was

$$V_t = 28.5 \text{ mV (from the IDX software screen).}$$

The calculation of CF follows:

$$CF = \frac{1.47}{28.5} \times 10.8 = 0.56 \text{ mW/g.}$$

## 4.0 Data Acquisition Methodology

### 4.1.0 E-field Measurement

The probe calibration must be current before starting measurements. Instrumentation amplifier batteries must be charged. This can be monitored by observing DC offset voltages. A daily log of DC offset voltages should be kept for this purpose.

Measurements in the phantom are automatically calculated for each location by summation of the three dipole outputs. Because each dipole produces an output voltage proportional to the square of the electric field component along the dipole, the sum of dipole voltages represents the RMS value for the total electric field. Thus, taking into consideration the “amplifier setting” and the DC offset voltages, the total electric field strength at a measurement location is as discussed in Appendix D.  $E_{tot}$  is labeled by the IDX software as “Measure of Values (volts)”. The SAR for calculations that are derived from the “Measure of Values” are discussed below.

At each measurement point, the program records the output of the three channels:

$$E_1 = V_1 - DC_1$$

$$E_2 = V_2 - DC_2$$

$$E_3 = V_3 - DC_3$$

$$E_{tot} = (E_1 \cdot AS_1) + (E_2 \cdot AS_2) + (E_3 \cdot AS_3) \text{ where}$$

$V_n$  = Voltmeter reading of channel n at one measurement point

$E_n$  = Actual voltage of channel n at one measurement point.

$AS_n$  is the amplifier setting of channel n

$E_{tot}$  = Total probe output at one measurement point [see Appendix C].

### 4.2.0 SAR Measurement

The goals of the measurement process are to scan the phantom over a selected area in order to find the region of highest levels of RF energy and then to obtain a single value for the peak spatial average of SAR over a volume that would contain one gram (in the shape of a cube) of biological tissue (brain or muscle). The test procedure, of course, measures SAR in the simulated tissue.

The IDX software requests the user to move the probe to locations at two extreme corners of a rectangle that encloses the area to be scanned. An arbitrary origin and the spatial resolution for the scan are also specified. Under program control, the scan is performed automatically by the robot-guided probe.

Next, using a higher spatial resolution, the robot guides the probe through locations with the highest SARs. Finally, the SAR is averaged over the cubic volume

surrounding the peak localized SAR. This spatially-averaged SAR is reported as “SAR (mW/g).

### 4.3.0 Data Extrapolation

Because the highest local SAR will occur too close to the phantom surface for access by the probe, an extrapolation method is used to calculate the local peak surface SAR from the SAR measured at a short distance from the surface. This distance is determined by the offset of the dipole from the physical end of the probe (“probe offset”, typically 0.4 cm). At the measurement point over the plane where the highest probe voltage was recorded (the "hot-spot"), the field is measured as close as possible to the phantom surface and every 0.5 cm along a path normal to the probe axis (Z axis) for a distance of 5 cm. An average slope is obtained from the three data points nearest the surface and used to define an exponential decay of the energy density with depth using the following relations. See Appendix E.

$$\text{Slope} = \frac{\frac{E_{\text{tot}Z_1}}{E_{\text{tot}Z_2}} + \frac{E_{\text{tot}Z_2}}{E_{\text{tot}Z_3}}}{2}$$

$$\text{exp} = \ln(\text{Slope}) \cdot \frac{\text{Offset}}{\text{Spacing}}$$

$$E_{\text{tot}Z_0} = E_{\text{tot}Z_1} \cdot e^{\text{exp}}$$

Where:

$E_{\text{tot}Z_n}$  = Total voltage at point n (1-11) (in the +Z direction) (measured value)

$E_{\text{tot}Z_0}$  = Total voltage for dipole at phantom surface (extrapolated value)

Offset = Distance from center of probe dipoles to outside of probe case

Spacing = Distance between measurement points (in Z)

### 4.4.0 Data Interpolation and Gram Averaging

The voltage 1 cm above the phantom surface ( $E_{\text{tot}1\text{cm}}$ ) is needed to calculate the exposure of one gram of simulated tissue. The SAR value that estimates the average over a 1 gram cube is obtained from the extrapolated value,  $E_{\text{tot}Z_0}$  and interpolated value,  $E_{\text{tot}1\text{cm}}$ , is obtained by interpolation (see Fig. 3.2.1.c).

$$\text{SAR}(mW/g) = \frac{E_{\text{tot}Z_0} + E_{\text{tot}1\text{cm}}}{2} \cdot \frac{\text{CF}}{\text{Sensor Factor}}$$

## **5.0 Phantoms**

A phantom is a device which simulates the size, contours, and electrical characteristics of human tissue at normal body temperature. It is composed of a solid shell and a simulated tissue solution.

### **5.1.0 Phantom Shells**

The shells are made of Fiberglas™, which is transparent to RF energy, and are as thin as possible (approximately 1.5 mm) while maintaining the strength necessary to hold as much as 150 pounds of simulated tissue.

a. Currently, phantoms in use are: Half-Body Phantoms (both left-ear and right-ear versions) for evaluating the RF exposure of users of telephone-type devices, a Full-Body Phantom for portable (two-way) products and personal communicators, and a Flat Phantom for experimental investigations. Each phantom is mounted on a non-metallic base or stand.

### **5.2.0 Simulated Tissue**

The solution which simulates the dielectric constant and conductivity of human tissue was devised by George W. Hartsgrove and his colleagues at the University of Ottawa, Canada

#### **5.2.1 Preparation**

- a. Select the phantom appropriate for the device to be measured.
- b. Determine the volume of the phantom by filling it with carefully measured amounts of water and recording the total. The volumes of phantoms currently in use are: Half-Body: 13 liters, Full-Body: 53 liters, and Flat: 21 liters. The density of the simulated tissue is approximately 1.25 g/cm<sup>3</sup>. Multiply the measured volume of the phantom by 1.33 to obtain the needed mass of simulated tissue. The result will be enough simulated tissue to fill the phantom and also provide some excess for verification of the electrical characteristics.
- c. Select the appropriate simulated tissue type: Muscle or Brain.
- d. From the following table determine the percentage of each ingredient and, based on the volume obtained above, calculate the mass of each ingredient. The sugar and salt are common household materials available at any supermarket.
- e. Obtain a clean container in which the ingredients will be mixed. Volumes less than 15 liters can be mixed in a 5-gallon plastic bucket, but larger volumes are best prepared in a clean 30-gallon plastic container.

<b>Simulated Tissue</b>		
<b>Ingredient</b>	<b>Muscle</b>	<b>Brain</b>
Water	53.58%	40.3%
Sugar	44.25%	56.0%
Salt	1.15%	2.5%
HEC	1.0%	1.0%
Bactericide	0.1%	0.2%

Fig 5.2.1.a -Table of Simulated Tissue Ingredients by Mass

f. Make a stirring paddle which will not be corroded by the salt in the simulated tissue. For example, two pieces of stainless steel can be welded together, attached to a 1/4" diameter rod about 18" long with the flat piece cut to about 2" x 3" x 1/16" with diagonally opposite corners bent up to create better stirring action. Mount the paddle on a variable-speed electric drill. (Observe appropriate precautions in using electrical appliances near salt water.)

g. Obtain the calculated amount of *Reverse-Osmosis* or *De-Ionized* water. For simulated tissue volumes less than 15 liters, pour about 25% of the water into a glass beaker, heat it on a hot plate to almost boiling, and then add it to the cold water. For larger volumes, arrange to have the entire quantity of water heated in a non-metallic container to 40° C (100-105° F).

h. While the water is being heated, weigh the dry ingredients (use the "Tare" or "Zero" feature for easier weighing).

- Place a container on the scale. Zero the scale. (“weight”)
- Pour salt into the container until the desired mass is reached. Re-zero.
- Pour Dowicil 75 (bactericide) into the container until the desired mass is reached. Put container aside.
- Place a second container on the scale. Zero the scale.
- Pour hydroxyethylcellulose (HEC) into the container until the desired mass is reached. Put container aside.

i. When the water is ready, slowly add salt and bactericide while stirring at low speed. Position the stirring paddle to minimize the amount of air bubbles generated in the solution. Continuously move the drill and paddle in a circular motion to ensure complete mixing throughout the container.

- j. Obtain accurate net weights of sugar which is added to the container while stirring continuously at low speed until totally dissolved.
- k. Add the HEC slowly to avoid clumping. Continue to stir until the solution thickens.
- l. Total stirring time should be 30-35 minutes.
- m. This procedure is described in a program (TISSUE.BAS) which also calculates and prints the amounts of ingredients required based on the type of simulated tissue desired and the quantity to be made.

### 5.2.2 Electrical Characteristics Measurement

- a. Before a batch of simulated tissue can be used for SAR measurements, its electrical characteristics (dielectric constant and conductivity) must be determined to ensure that the simulated tissue was properly made and will simulate the desired human characteristics. A coaxial slotted line with probe is used to measure RF amplitude and phase changes versus distance in the simulated tissue as shown below.

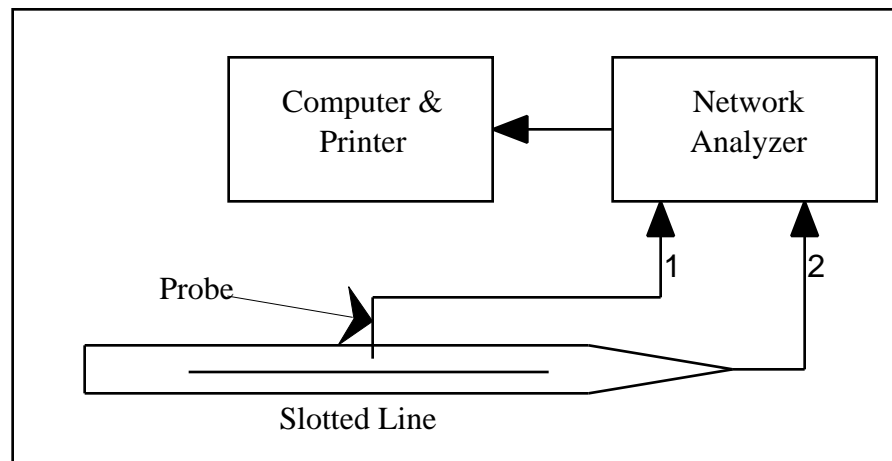

Fig.5.2.2.a -Equipment used for Dielectric Constant and Conductivity Measurement

- b. Before using the slotted line, inspect it carefully to be sure the inside is clean and free of foreign matter.
- c. Clean the area about 1 cm wide along each side of the slot with a light abrasive (such as emery cloth) to remove any oxidation. Similarly, clean the underside of the probe outer structure to ensure a good noise-free contact with the slotted line. Take care to avoid damage to the probe center conductor.
- d. Cover most of the slot with masking tape. At the end of the slot nearest the input connector, leave uncovered an area about as long as the slot is wide.

e. Using a large syringe, draw up a sample of room-temperature simulated tissue. Ensure that the sample is as free as possible of air bubbles. Inject the sample into the hole in the end of the slotted line opposite the input connector. Repeat this process until a small amount of simulated tissue flows from the area not covered by tape. Remove the masking tape. Make sure that the slot is full of simulated tissue and free of air bubbles. Attach a centimeter scale to the slotted line so that measurement points can be accurately located.

f. Connect Port 1 of the network analyzer to the probe, and Port 2 to the slotted line.

g. Insert the probe in the slot at the end nearest the input connector, making sure that the simulated tissue is flush with the outside surface of the line. Align one end of the probe with a line on the centimeter scale.

h. If the network analyzer is a Hewlett-Packard Model 8753C, set it as follows:

<u>Hard Key</u>	<u>Soft Key</u>
Preset	
Meas	S12
Display	Dual Chan On
CH 2	
Meas	S12
Format	Phase
Menu	CW Freq (Enter frequency on numeric keypad. Terminate with appropriate units key.)
Power	23 xl (Port 2 ref power in dBm) Verify that "Power Trip" is OFF. If ON, reduce power, set "Power Trip" OFF.
MKR	

i. Other analyzers should be set similarly (S12 log magnitude and phase displayed simultaneously, power set high enough so measurements do not get noisy).

j. Measurement:

- Slowly move the probe back and forth perpendicularly to the slotted line until the highest amplitude response is obtained. Data not stable within 0.1 unit are an indication of noisy electrical contact between the probe and the slotted line. Record the amplitude and phase to the nearest 0.1 dB or 0.1°. Move the probe 1 cm toward the far end of the line.
- Repeat this process until 11 data points (corresponding to 10 cm) have been measured.

Brain mixture @ 835 MHz 06-16-1995			
1	Amplitude	-30.3,	Phase 92.4
2		-32.1,	27.3
3		-34.2,	-41.9
4		-36.5,	-109.6
5		-38.8,	-179.4
6		-40.8,	114.2
7		-43.3,	45.3
8		-45.3,	-21.2
9		-47.5,	-90.2
10		-49.6,	-155.6
11		-51.9,	135.1
Dielectric Constant		Conductivity	
43.70992		.9057107	

Fig. 5.2.2.b -Simulated tissue electrical characteristics: measured data

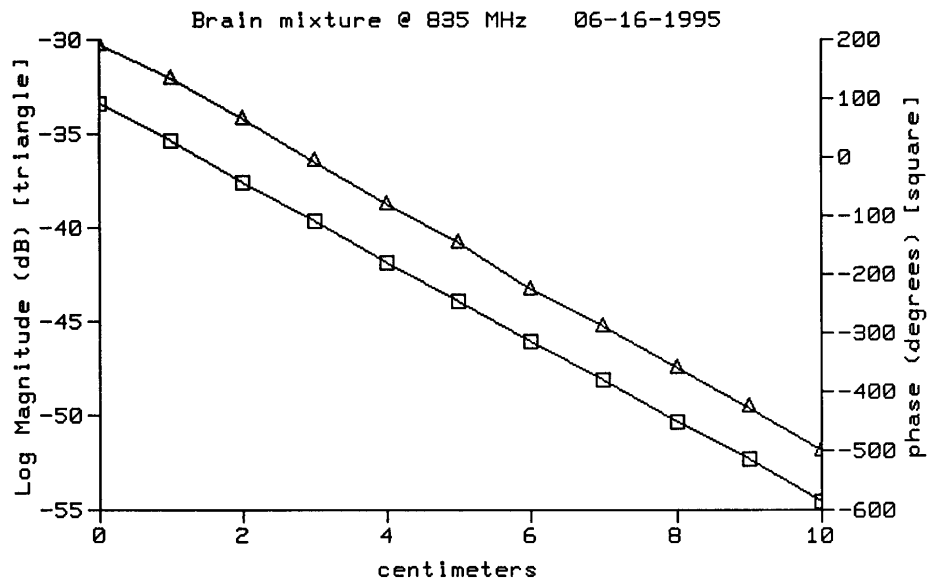

Fig. 5.2.2.c -Simulated tissue electrical characteristics: plotted data

k. Execute the TISSUCHK.EXE program and enter the measured amplitude and phase data as shown above. When the data are plotted, examine the linearity of the curves to judge the validity of the calculated dielectric constant and conductivity. If only one point on a curve is out of line, re-measure just the one point. If more than one point is wrong, repeat the entire measurement. Once the data are satisfactory, the calculated values should be compared with those in the following table. The values in the table are from Gabriel and Foster, which also contains graphs of  $\epsilon_r$  and  $\sigma$  versus frequency for several types of simulated tissue.  $\epsilon_r$  is defined as relative dielectric constant and  $\sigma$  is conductivity (S/m). Agreement to within 3% for dielectric constant and conductivity is satisfactory.

Simulated Tissue	r		r		r	
	100 MHz	(S/m)	400 MHz	(S/m)	900 MHz	(S/m)
Muscle	70.5	0.68	62.5	0.90	54.7	1.38
Brain	63.0	0.47	50.3	0.75	41.2	.9

Fig. 5.2.2.d - Typical values for dielectric constant and conductivity at several frequencies

l. The measured data and calculated values and plot must be identified with the type of simulated tissue, frequency, date of measurement, and kept in a file in the measurement area.

m. The simulated tissue should be used soon after preparation and stored so as to prevent evaporation of the water. After prolonged use, a sample should be taken for dielectric measurement to assure there has been no change in properties. In the absence of biological degradation and significant evaporation, the simulated tissue can be used for several months.

### 5.2.3 Determining Relative Dielectric Constant and Effective Conductivity

a. The data from the slotted line are used to determine the relative dielectric constant and effective conductivity (that includes contributions from both dielectric and ohmic processes) from the following relationships (see Appendix F):

$$r = \frac{2 \mu}{\mu_0} \quad (1)$$

$$\text{effective} = \frac{2}{\mu} \quad (2)$$

and are determined by averaging, respectively, the attenuation (dB/cm) and phase shift (deg/cm) over the length of the slotted line. The attenuation and phase shift are each determined for six pairs of points. Each of the pairs of points are from measurements separated by 5 cm. For example, the attenuations and phase shifts at Z=1 cm and Z=6 cm define dB<sub>1</sub> and deg<sub>1</sub>:

$$\begin{aligned} \text{dB}_1 &= \text{Mag}(Z = 6 \text{ cm}) - \text{Mag}(Z = 1 \text{ cm}) \\ &= -40.8 \text{ dB}_m - (-30.3 \text{ dB}_m) = -10.5 \text{ dB, and} \end{aligned}$$

$$\begin{aligned} \text{deg}_1 &= \text{Phase}(Z = 6 \text{ cm}) - \text{Phase}(Z = 1 \text{ cm}) \\ &= -245.8 \text{ deg} - (92.4) \text{ deg} = -338.2 \text{ deg.} \end{aligned}$$

In a similar fashion (Appendix F), obtain data for  $dB_2$  to  $dB_6$  and  $deg_2$  to  $deg_6$  and then average each series to get

$$\text{avg (dB/cm)} = \frac{\sum_{n=1}^6 dB_n}{6}, \text{ and}$$

$$\text{avg (deg/cm)} = \frac{\sum_{n=1}^6 deg_n}{6}.$$

The values of  $\text{avg}$  and  $\text{avg}$  must be converted to units of (Np/cm) and (rad/cm) using these relations (see Appendix F for details):

$$\text{avg (NP/cm)} = \frac{\ln(10) \cdot \text{avg (dB/cm)}}{20}, \text{ and}$$

$$\text{avg (rad/cm)} = \frac{\text{avg (deg/cm)} \cdot \pi}{180}.$$

Finally, use (1) and (2) to obtain  $r$  and  $\epsilon_{\text{effective}}$  from  $\text{avg}$ ,  $\text{avg}$ , and  $\lambda = 2/f$ , where  $f$  is the frequency of the RF field.

An alternative method of calculation follows:

$$c = 3 \cdot 10^8 \text{ m/s}, \quad A = \frac{A}{20} \cdot \ln(10) \text{ 1/m}, \quad \lambda = \frac{2 \cdot c}{f}$$

$1/\text{m}$ ,

$$r = \frac{c}{F} \cdot \frac{100}{2.54} \text{ inches}, \quad \epsilon_{\text{re}} = (A^2 + \epsilon_{\text{eff}}^2) \cdot \frac{2}{(4 \cdot \lambda)^2}$$

$$\epsilon_{\text{eff}} = \text{as in } |A| \cdot \frac{1}{4 \cdot \lambda \cdot \sqrt{\epsilon_{\text{re}}}} \quad S = \tan(2 \cdot \epsilon_{\text{eff}})$$

Where:

$A$  is the amplitude attenuation in dB

$\epsilon_{\text{eff}}$  is the phase change in degrees, for 5 cm of wave propagation in the slotted line

$F$  is the frequency of interest in Hertz

$\epsilon_{\text{re}}$  is the real part of the complex dielectric constant

$$\epsilon_r = \frac{\epsilon_{re}}{\sqrt{1 + S^2}}, \quad \sigma = S \cdot 2 \cdot \pi \cdot F \cdot 8.854 \cdot 10^{-12} \cdot \epsilon_r \text{ S/m}$$

The results:  $\epsilon_r$  is the relative dielectric constant and  $\sigma$  is the conductivity in S/m.

Figure 5.2.3.a shows the two calculational comparison of methods used above.

	Rigorous Method	Alternative Method	Percent Difference
Dielectric Constant	43.7	42.4	-3.1
Conductivity	0.906	0.879	-3.1

Fig. 5.2.3.a - Table comparing mixture analysis methods;

## 5.3 Determining the Heat Capacity of Simulated Tissue

### 5.3.1 Instruments and Materials

- Calibrated differential thermometer (Vitek or BAT-8)
- Two identical 500 milliliter (ml) containers
- A thermally-insulated vessel (thick styrofoam, with a form-fitting hole for one container)
- Hot and cold tap water
- Solution under test
- Hot plate
- Temperature vs. time (chart) recorder

### 5.3.2 Method

Heat can be propagated by conduction, convection, and radiation. In the case of liquids heated from below, gravity convection is the main and predominant heating mechanism of the fluid mass.

Obtain two containers that can be rapidly heated (e.g., glass or suitable plastic). Fill one container with 250 ml of water; the other with the same mass of simulated tissue. The initial temperature of the water should be the same as that of the simulated tissue ( $\pm 1^\circ\text{C}$ ). Since we are dealing with heating by electromagnetic sources at ambient temperature, it is essential that we eliminate the chance of any direct infrared heating of the temperature sensor. To ensure this, position the tip of the sensor 2 mm from the bottom of the center of the container. Turn on the heat source and wait at least 5 minutes for its temperature to stabilize. Record the initial temperature of the water. Place the container of water 5 mm above the center of the hot plate and monitor the temperature increase.

After 30 seconds of heating, the water temperature should have increased by at least  $5^\circ\text{C}$ . Record the time and temperature. Remove the container from the heat

source and place it in the thermally-insulated vessel. Stir the liquid thoroughly and record the steady-state temperature 1-2 minutes after stirring.

Repeat the above procedure using the container of simulated tissue. Ensure that the container is placed on the same area of the hot plate, is heated for the identical length of time, and the steady-state temperature is recorded after the identical time interval.

Since the heat capacity of water is  $C_W = 1 \text{ cal/}^\circ\text{C/g}$  with excellent approximation ( $\sim 1\%$ ) in the temperature range of interest, the heat capacity ( $C_S$ ) of the solution is given by

$$C_S = C_W \frac{T_W}{T_S}$$

where  $T_W$  is the temperature increase of water and  $T_S$  the temperature increase of the solution. The ratio of the values,  $T_W/T_S$ , should be the same (within the sensitivity of the thermometer) at the end of the heating and stirring. This ensures that the liquids have been uniformly heated.

### 5.3.3 Rationale

$C \Delta T = \text{Heat flow} \times \text{time} = \text{Total Heating Energy}$

If the heat flow, sample mass, and absorption (heat transfer) are the same for both liquids, then

$$C_W \Delta T_W = C_S \Delta T_S$$

The heat flow and total heating are kept constant by using the same source for the same amount of time. If the heat transfer mechanisms for the two liquids are about the same, with insignificant differences in convective and conductive characteristics, then any differences in temperature increase are a direct measure of the specific heat capacity,  $C$ .

## APPENDIX

### Appendix A. Wire Stripper

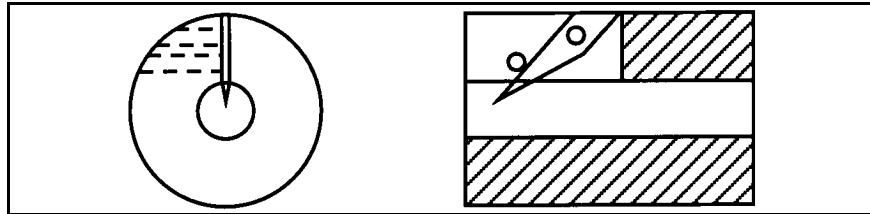

Fig. A.1 - Wire stripper design

The drawing above shows the design of a custom wire stripper. A piece of 1" aluminum rod, 1-1/2" long, has a 9/32" hole drilled through its center. A slot is cut part way through one side of the resulting cylinder, and two 6-32 holes are tapped through the wall up to, but not beyond, the slot. Socket-head set-screws are threaded into the holes; one screw to hold an X-Acto blade in place, and the other to keep the blade from pivoting on the first screw. The blade should be adjusted so it cuts *almost* all the way through the insulation, but *does not touch* the thin film protecting the carbon.

To use the stripper, cut the end of a piece of the high-impedance wire at a sharp angle. Insert the wire into the stripper so the end passes by the blade and emerges from the hole. Grasp the wire with pliers and pull it through the stripper. Insert the wire again so the blade will cut the opposite side and pull it through. Carefully peel the insulation apart, leaving the inner fiber unharmed.

### Appendix B. Cable Construction

To make a set of three cables, obtain the following materials:

- 3 Hirose 0905336N01 connectors
- 1 foot each red and black 22 AWG stranded wire
- 18 2-inch pins made of very stiff copper or copper-plated wire, sharpened to a point on both ends
- 6 2-foot pieces of high-impedance wire
- 6 pieces of high-impedance wire, cut to the desired cable length
- 12 crimp lugs to fit the stripped high-impedance wire
- 12 crimp lugs to fit the un-stripped high-impedance wire
- 2 feet each red and black test lead wire
- 2 feet 1/2" tinned copper braid
- 6 2-foot pieces of clear shrink sleeving to fit the stripped high-impedance wire
- Black shrink sleeving as needed
- 3 3-56 pan head screws, 1/4" long
- 3 #3 flat washers

**Note:** The high-impedance wire is Belden 7mm IRS/350 Spark Plug Wire. It is available on 100-foot spools from NAPA Auto Parts as #734601. Purchase enough spools to make a complete set of cables. Specify that they all be from the same batch because impedance varies from batch to batch.

Strip the rubber insulation from the 2-foot pieces of high-impedance wire. Cover the pieces with clear shrink sleeving to protect the film and carbon. Inside a Hirose connector, tie pins 1, 2, and 3 together, then solder them to the black stranded wire. Tie pins 4, 5, and 6 together and solder them to the red stranded wire. Reassemble the connector and cut the wires 1" from the connector shell. Solder the two wires to two pins.

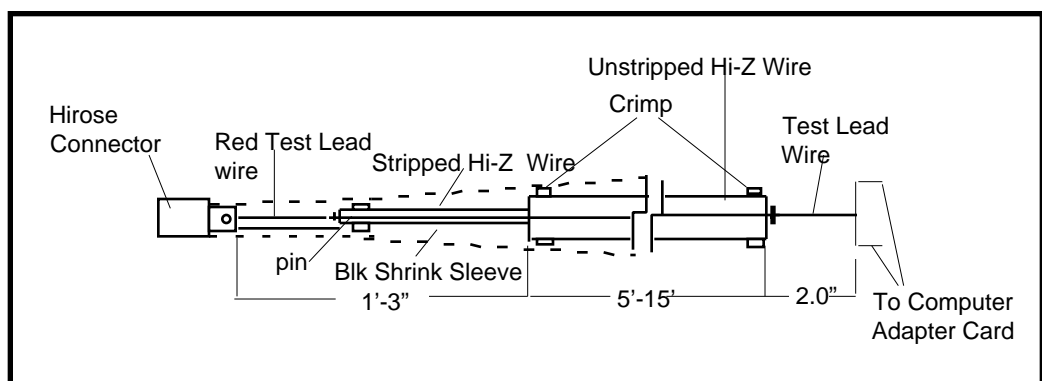

*Fig. B.1 -Details of high-impedance cable construction*

Slide a large lug over the end of a piece of the un-stripped high-impedance wire. Solder the red test lead wire to a pin. When the solder has cooled, insert the entire pin lengthwise into the carbon portion of the high-impedance wire. Position the lug at the end of the wire and crimp it. Similarly, join the other end of the high-impedance wire to a piece of the stripped high-impedance wire using a pin, a large lug, and a small lug. Use a small lug to join the other end of the stripped high-impedance wire to the pin attached to the red wire on the Hirose connector.

Repeat the above paragraph using the black test lead wire. Cover each pair of joints with a 2" piece of black shrink sleeving. Attach the two wires together with a tie-wrap every 3 feet along the un-stripped high-impedance wires. Cut the two test lead wires to 6" length and connect them to the computer adapter card with the black wire in the ground side. Cover each lug with a 1" or 1-1/2" piece of black shrink sleeving. Cut a 6" piece of the copper braid. Mark a 1/4" x 1/4" area centered 3/8" from one end of the braid. Apply solder to the area to reinforce it. Drill a small hole in the center of the area. Remove and discard the set screw from the side of the Hirose connector. Slide the braid over the connector, unsoldered end first. Attach the braid to the connector with a screw and flat washer. Provide strain relief with cable tie.

Repeat this entire procedure for the second and third cables.

## Appendix C. Definition of “Amplifier Setting” and other terms related to sensor calibration

The initial sequence of probe calibrations steps performed with SAR determinations produces the factors used in scaling probe output voltage to RF power density. For historical reasons all probe factors are compared to a factor 10.8 mV per mW/cm<sup>2</sup> that was typical of a prototype probe, but is in fact an arbitrary figure. The factor of  $\frac{10.8 \text{ mV}}{(\text{mW}/\text{cm}^2)}$  is known as “sensor factor”, but does not change. To calibrate a probe, each channel is assigned an “amplifier setting”. This factor is obtained from the maximum probe output voltage measured during probe calibration. This probe output voltage is corrected for any DC offset of the instrumentation amplifier, usually a very small amount.

During calibration, the channel-3 dipole is aligned parallel to the E-field, but each of the channel 1 and 2 dipoles is at 45° to the direction of the field, resulting in outputs one-half as large. Thus, the amplifier settings for each channel are as follows:

$$AS_1 = \frac{\frac{\text{Sensor Factor}}{2}}{V_{\text{max}_1} - DC_1}$$

$$AS_2 = \frac{\frac{\text{Sensor Factor}}{2}}{V_{\text{max}_2} - DC_2}$$

$$AS_3 = \frac{\text{Sensor Factor}}{V_{\text{max}_3} - DC_3}$$

Where:

$AS_n$  = Amplifier Setting for Channel n

Sensor Factor = an arbitrary value  $\frac{10.8 \text{ mV}}{\text{mW}/\text{cm}^2}$

$V_{\text{max}_n}$  = Maximum voltage recorded for channel n by rotation about the probe axis with the probe in a TEM Cell (E perpendicular to the probe axis)

$DC_n$  = DC-offset of channel n (the voltage out of the high-impedance cables with the instrumentation amplifier on and RF power off, recorded at the beginning of probe calibration)

## Appendix D. Note on Units and Various Calibration Factors

Three calibration factors, already defined, are used in the process of obtaining electric field strengths and SARs. This note shows how the units applicable to each are consistent and produce suitable units for the final quantities. The units of  $E_{\text{tot}}$  are also discussed.

a) Sensor Factor is a numerical constant fixed by the properties of a particular probe used in the past. It represents the voltage output from a probe placed in a flux density of  $1 \text{ mW/cm}^2$ .

$$\begin{aligned}\text{Sensor Factor} &= 10.8 \text{ mV} / (\text{mW/cm}^2) , \text{ or} \\ &= 0.0108 \text{ V} / (\text{mW/cm}^2) .\end{aligned}$$

b) Amplifier Setting (AS) is a calibration factor that reflects the probe and amplifier properties. The values of AS for each channel are computed by the software. The data for the values of each AS are obtained when the E-field probe is rotated for maximum output from the probe channels while in a TEM cell with a field strength of  $1 \text{ mW/cm}^2$ . The AS values are shown on screen and in the output as “Amplifier Channel Settings.”

Numerically, each AS is scaled according to Sensor Factor and therefore has the units of  $(\text{mW/cm}^2)^{-1}$ . See Appendix C for definitions.

c) Conversion Factor (CF) is in units of  $(\text{mW/g})$ . See Sec. III.B.2. CF calibrates the electric field probe output voltage in terms of the temperature-based measurement of SAR. The numerical value of CF depends on the probe in use and on the accuracy of the temperature measurements during the calibration in the flat phantom.

For a simple example, assume only channel 3 of the probe had a non-zero output. If  $\text{CF} = 0.56 (\text{mW/g})/\text{V}$ ,  $\text{AS}_3 = 0.375$ , and  $E_3 = 350\text{mV}$ , the SAR at this location is

$$\begin{aligned}\text{SAR} &= E_3 \times \text{AS}_3 \times \text{CF} (\text{Sensor Factor}) , \\ \text{SAR} &= 0.350 \times 0.375 \times 0.56 / 0.0108 = 6.81 \text{ mW/g} .\end{aligned}$$

The appearance of the Sensor Factor in the denominator for the SAR calculation effectively cancels the introduction of the same scaling constant (10.8) used in making the calculation of CF (Sec. III.B.2.). See above for discussions of the units for AS and Sensor Factor.

The numerical scaling for CF is based on the TEM cell measurements where a test flux density of  $1 \text{ mW/cm}^2$  was used. This flux density corresponds to an electric

field strength in the TEM cell of 0.614 V / cm, or the squared value of 0.377 V<sup>2</sup>/cm<sup>2</sup> ( E<sup>2</sup> ). For historical reasons, CF is defined in terms of an intermediate scaling constant for a particular probe which produced an output of 10.8 mV in the TEM cell when the field strength was 0.614 V/ cm.

d) The units of the total output of the probe, E<sub>tot</sub> ( see section 4.0 ) are [ V/ (mW/cm<sup>2</sup>) ]. This unusual unit, the same as the unit for Sensor Factor, follows from the definition of E<sub>tot</sub> in terms of the amplifier setting factors which are normalized to 1 mW/cm<sup>2</sup> . (In physical terms, the probe voltages are developed in diodes and represents an electric field squared (V<sup>2</sup>/cm<sup>2</sup>) and equivalently a power density (mW/g). Therefore, E<sub>tot</sub> is physically appropriate for measurement of SAR.) To obtain the power density corresponding to E<sub>tot</sub> perform the following calculation,

$$\text{SAR} = E_{\text{tot}} \times \text{CF} / (\text{Sensor Factor}),$$

or to show the units explicitly,

$$\text{SAR [mW/g]} = E_{\text{tot}} [ \text{V/ (mW/ cm}^2\text{)} ] \times \text{CF (mW/g)/ Sensor Factor [ V/(mW/cm}^2\text{)} ].$$

## Appendix E. Derivation of Extrapolation Method

For a plane wave incident on a dielectric medium, the incident electric field  $E_0$  is attenuated exponentially with depth in the medium. Thus measuring depth along the Z direction,  $Z$ , the electric field strength at depth Z is,

$$E(Z) = E_0 e^{-Z/\lambda}$$

or,

$$E_0 = E(Z) e^{Z/\lambda}$$

The power density at Z and E<sub>tot</sub> are exponentially decreasing. This means that the corresponding relation for E<sub>tot</sub> at Z<sub>0</sub> , the total probe output at the surface of the phantom shell is,

$$E_{\text{tot}} Z_0 = E_{\text{tot}} Z_n e^{2Z/\lambda}, \quad (1)$$

where Z<sub>n</sub> is the n-th data point away from the phantom surface,

Z<sub>n</sub> = Z<sub>off</sub> + (n-1) Z, n = 1,2,3. For example, the first two data points are Z<sub>1</sub> = Z<sub>off</sub>, and Z<sub>2</sub> = ( Z<sub>off</sub> + Z ). Z<sub>off</sub> is “Offset,” the distance from the end of the probe to the location of the dipole (usually 0.4 cm). Z is “Spacing,” the distance between the measurement points (usually 0.5cm). λ is an attenuation constant (similar to penetration depth).

The ratio of  $E_{\text{tot } Z_1}$  to  $E_{\text{tot } Z_2}$  is,

$$\begin{aligned} \frac{E_{\text{tot } Z_1}}{E_{\text{tot } Z_2}} &= e^{2(Z_2 - Z_1) / \lambda} \\ &= e^{2Z / \lambda} \end{aligned}$$

The ratios of any two adjacent points are, in theory, equal:

$$\frac{E_{\text{tot } Z_1}}{E_{\text{tot } Z_2}} = \frac{E_{\text{tot } Z_2}}{E_{\text{tot } Z_3}} = e^{2Z / \lambda} \quad (2)$$

Therefore, by averaging the experimentally obtained ratios it is possible to get a more accurate estimate for the argument of the exponential,  $2Z / \lambda$ . Define "Slope" as this experimental quantity that averages over the two intervals defined by  $Z_1$ ,  $Z_2$  and  $Z_3$ .

$$\text{Slope} = \frac{\left( \frac{E_{\text{tot } Z_1}}{E_{\text{tot } Z_2}} + \frac{E_{\text{tot } Z_2}}{E_{\text{tot } Z_3}} \right)}{2}$$

Taking the logarithm of (2) and using Slope instead of either  $(E_{\text{tot } Z_1} / E_{\text{tot } Z_2})$  or  $(E_{\text{tot } Z_2} / E_{\text{tot } Z_3})$ ,

$$\ln(\text{Slope}) = 2Z / \lambda$$

Substitute for the argument in (1) (with  $n = 1$ ) to find the following expression for  $E_{\text{tot } Z_0}$ , the desired value at the surface of the phantom shell,

$$\begin{aligned} E_{\text{tot } Z_0} &= E_{\text{tot } Z_1} e^{2Z / \lambda} \\ &= E_{\text{tot } Z_1} e^{(2Z / \lambda) \cdot \ln(\text{Slope})} \end{aligned}$$

## Appendix F: Complex Permittivity Measurements

### F.1 Rigorous Method

Maxwell's Equations

$$\nabla \times \mathbf{E} = -j \omega \mu \mathbf{H}$$

$$\nabla \times \mathbf{H} = (j \omega \epsilon' + \sigma) \mathbf{E}$$

$$\epsilon' = \epsilon'' - j \sigma / \omega$$

$$\nabla \times \mathbf{H} = j \omega (\epsilon' - j \sigma / \omega) \mathbf{E}$$

$$\nabla \times (\nabla \times \mathbf{E}) = \nabla \times (-j \omega \mu \mathbf{H}) = -j \omega \mu (\nabla \times \mathbf{H})$$

$$\nabla^2 \mathbf{E} = -\omega^2 \mu (\epsilon' - j \sigma / \omega) \mathbf{E} \text{ using } \nabla \cdot \mathbf{E} = 0$$

$$-\nabla^2 \mathbf{E} + \omega^2 \mu (\epsilon' - j \sigma / \omega) \mathbf{E} = 0$$

$$\text{Where: } -\nabla^2 = \omega^2 \mu (\epsilon' - j \sigma / \omega)$$

$$\text{Solution: } E(z) = E^+ e^{-\gamma z} + E^- e^{+\gamma z}$$

$E^+ e^{-\gamma z}$  represents a TEM wave traveling in the +z direction.  $E^- e^{+\gamma z}$  is the reflected wave which is very much attenuated in typical lossy mixtures in coaxial lines and thus can be ignored.

$$\text{Define } \gamma^2 = (\alpha + j\beta)^2 = -\omega^2 \mu (\epsilon' - j \sigma / \omega)$$

$$\text{Re } \gamma^2 = \alpha^2 - \beta^2 = -\omega^2 \mu \epsilon'$$

$$\text{Im } \gamma^2 = 2\alpha\beta = +\omega^2 \mu (\sigma / \omega)$$

$$= \omega^2 \mu (\sigma / \omega)$$

$$= \mu \text{ effective}$$

$$\alpha = 0 \quad r = \frac{\alpha^2 - \beta^2}{-\omega^2 \mu}$$

## Results for General Lossy Mediums

$$r = \frac{\epsilon_r - 2}{2\mu_0} \quad (1)$$

$$\text{effective} = \frac{2}{\mu} \quad (2)$$

Where:

$r$  = relative dielectric constant (unit-less)

$\epsilon_0$  = permittivity of free space ( $8.854 \times 10^{-14}$  F/cm)

$\beta$  = propagation constant (rad/cm)

$\alpha$  = attenuation constant (Np/cm)

$\omega$  = angular frequency (rad/sec)

$\mu_0$  = permeability of free space ( $4 \times 10^{-9}$  H/cm)

$\mu$  = permeability of the mixture ( $= \mu_0$  because the mixtures are non-magnetic)

$\sigma$  = equivalent conductivity (Siemens/cm)

We must now find  $\alpha$  (Np/cm) and  $\beta$  (rad/cm) to be able to use the derived equations. Let  $V_2 = V_1 e^{-\gamma z}$  where  $V_1$  is the voltage measured at one point near the connector end of the coaxial slotted line and  $V_2$  is the voltage measured at another point  $z$  (cm) farther away from the connector. Between each two points, a phase shift of  $(-\beta z)$  results. Also,  $\alpha > 0$ ,  $\beta > 0$ ,  $z > 0$ .

$$\text{Then: } \frac{V_2}{V_1} = e^{-\gamma z}$$

$$\ln \frac{V_2}{V_1} = -\gamma z$$

and therefore:

$$(\text{Np/cm}) = \frac{-\ln \frac{V_2}{V_1}}{z} \quad (3)$$

Measured data do not give  $\alpha$  and  $\beta$  in units of Np/cm and rad/cm respectively; a conversion is necessary.

By definition,

$$(dB/cm) = \frac{-20 \log_{10} \frac{V_2}{V_1}}{z} \quad (4)$$

Comparing equations 3 and 4 gives the relation:

$$(Np/cm) = \frac{\ln(10) \cdot (dB/cm)}{20} \quad (5)$$

In addition,

$$(rad/cm) = (deg/cm) \cdot \frac{\pi}{180} \quad (6)$$

Equations 5 and 6 provide the necessary conversions to use  $\epsilon_r$  and  $\sigma$  directly in the equations derived for  $\alpha$  and  $\beta$  effective in general lossy mediums.

Amplitude and phase are measured over a 10 cm distance with 1 cm spacing between data points, giving 11 total data points. When the dB-versus-z and degrees-versus-z plots are drawn, straight lines should result. This would allow  $\alpha$  and  $\beta$  to be calculated over whatever multiple of z was desired. Since the plots are not perfectly straight, but usually very close, the dielectric constant and conductivity are computed using the absolute value of the average of the slopes of the dB-versus-z and degrees-versus-z data between points n and n+5 for n = 1, 2, 3, ....6.

We get:

$$\text{avg } (dB/cm) = \frac{\left| \begin{array}{c} 6 \\ \frac{dB_{n+5} - dB_n}{5cm} \\ n=1 \end{array} \right|}{6} \quad (7)$$

and

$$\text{avg } (deg/cm) = \frac{\left| \begin{array}{c} 6 \\ \frac{deg_{n+5} - deg_n}{5cm} \\ n=1 \end{array} \right|}{6} \quad (8)$$

each based on the average of 6 different slopes. Each slope comprising the average slope is based on a 5 cm distance but  $\alpha_{avg}$  and  $\beta_{avg}$  will have units involving per unit length.

Next,  $\alpha_{avg}$  and  $\beta_{avg}$  need to be converted to  $\alpha_{avg}$  (Np/cm) and  $\beta_{avg}$  (rad/cm) by using equations 5 and 6. Once this is done,  $r$  and  $\theta_{effective}$  can be calculated as shown in V.B.3.

### Example

The calculation is done using the 835 MHz measured data shown in the previous section. (Note: #6 Point is repeated)

$$\begin{aligned} dB_1 &= -40.8 - (-30.3) = -10.5 \text{ dB} \\ dB_2 &= -43.3 - (-32.1) = -11.2 \text{ dB} \\ dB_3 &= -45.3 - (-34.2) = -11.1 \text{ dB} \\ dB_4 &= -47.5 - (-36.5) = -11.0 \text{ dB} \\ dB_5 &= -49.6 - (-38.8) = -10.8 \text{ dB} \\ dB_6 &= -51.9 - (-40.8) = -11.1 \text{ dB} \end{aligned}$$

$$\begin{aligned} deg_1 &= -245.8 - (92.4) = -338.2 \text{ degrees} \\ deg_2 &= -314.7 - (27.3) = -342.0 \text{ degrees} \\ deg_3 &= -381.2 - (-41.9) = -339.3 \text{ degrees} \\ deg_4 &= -450.2 - (-109.6) = -340.6 \text{ degrees} \\ deg_5 &= -515.6 - (-179.4) = -336.2 \text{ degrees} \\ deg_6 &= -584.9 - (-245.8) = -339.1 \text{ degrees} \end{aligned}$$

It may be necessary to subtract multiples of 360 degrees from measured phase values to get proper phase changes.

Now:

$$\alpha_{avg} = \left| \frac{\frac{-10.5}{5} + \frac{-11.2}{5} + \frac{-11.1}{5} + \frac{-11.0}{5} + \frac{-10.8}{5} + \frac{-11.1}{5}}{6} \right| = +2.19 \text{ dB/cm}$$

$$\beta_{avg} = \left| \frac{\frac{-338.2}{5} + \frac{-342.0}{5} + \frac{-339.3}{5} + \frac{-340.6}{5} + \frac{-336.2}{5} + \frac{-339.1}{5}}{6} \right| = +67.85 \text{ deg/cm}$$

Note that  $\alpha_{avg}$  (dB/cm) and  $\beta_{avg}$  (deg/cm) are just the absolute value of the average of the 6 slopes on the data plots.

Using equations 5 and 6:

$$\text{avg} = \frac{\ln(10) \cdot 2.19}{20} = 0.252 \text{ Np/cm}$$

$$\text{avg} = \frac{67.8}{180} = 1.184 \text{ rad/cm}$$

Using the **Results for General Lossy Mediums** (1) and (2) gives:

$$r = \frac{(1.18)^2 - (0.252)^2}{(2 \cdot 835 \times 10^6)^2 \cdot 4 \times 10^{-9} \cdot 8.854 \times 10^{-14}} = 43.7$$

$$\text{effective} = \frac{2 \cdot 0.252 \cdot 1.18}{2 \cdot 835 \times 10^6 \cdot 4 \times 10^{-9}} = 9.06 \times 10^{-3} \text{ Siemens/cm}$$

Converting to *Siemens/m* gives:

$$\text{effective} = 9.06 \times 10^{-3} \text{ Siemens/cm} \cdot 100 \text{ (cm/m)} = 0.906 \text{ Siemens/m}$$