



FCC RF Test Report

APPLICANT : Motorola Mobility LLC
EQUIPMENT : Mobile Cellular Phone
BRAND NAME : Motorola
MODEL NAME : XT2075-1
FCC ID : IHDT56ZC1
STANDARD : 47 CFR Part 2, 22(H), 24(E), 27(L)
CLASSIFICATION : PCS Licensed Transmitter Held to Ear (PCE)

The product was received on May 27, 2020 and completely tested on Jul. 27, 2020. We, Sporton International (Kunshan) Inc., would like to declare that the tested sample has been evaluated in accordance with the procedures given in ANSI C63.26-2015 and shown compliance with the applicable technical standards.

The test results in this report apply exclusively to the tested model / sample. Without written approval of Sporton International (Kunshan) Inc., the test report shall not be reproduced except in full.

Jason Jia

Reviewed by: Jason Jia / Supervisor

James Huang

Approved by: James Huang / Manager



Sporton International (Kunshan) Inc.

No. 1098, Pengxi North Road, Kunshan Economic Development Zone Jiangsu Province 215300
People's Republic of China



TABLE OF CONTENTS

REVISION HISTORY... 3
SUMMARY OF TEST RESULT ... 4
1 GENERAL DESCRIPTION ... 5
1.1 Applicant ... 5
1.2 Manufacturer ... 5
1.3 Product Feature of Equipment Under Test ... 5
1.4 Product Specification of Equipment Under Test ... 6
1.5 Modification of EUT ... 6
1.6 Specification of Accessory ... 6
1.7 Re-use of Measured Data ... 7
1.8 Maximum ERP/EIRP Power, Frequency Tolerance, and Emission Designator ... 8
1.9 Testing Location ... 9
1.10 Test Software ... 9
1.11 Applicable Standards ... 9
2 TEST CONFIGURATION OF EQUIPMENT UNDER TEST ... 10
2.1 Test Mode ... 10
2.2 Connection Diagram of Test System ... 12
2.3 Support Unit used in test configuration and system ... 12
2.4 Measurement Results Explanation Example ... 12
2.5 Frequency List of Low/Middle/High Channels ... 13
3 CONDUCTED TEST ITEMS ... 15
3.1 Measuring Instruments ... 15
3.2 Test Setup ... 15
3.3 Test Result of Conducted Test ... 15
3.4 Conducted Output Power and ERP/EIRP ... 16
3.5 Peak-to-Average Ratio ... 17
3.6 Occupied Bandwidth ... 18
3.7 Conducted Band Edge ... 19
3.8 Conducted Spurious Emission ... 20
4 RADIATED TEST ITEMS ... 21
4.1 Measuring Instruments ... 21
4.2 Test Setup ... 21
4.3 Test Result of Radiated Test ... 21
4.4 Radiated Spurious Emission ... 22
5 LIST OF MEASURING EQUIPMENT ... 23
6 UNCERTAINTY OF EVALUATION ... 24
APPENDIX A. TEST RESULTS OF CONDUCTED TEST
APPENDIX B. TEST RESULTS OF RADIATED TEST
APPENDIX C. TEST SETUP PHOTOGRAPHS
APPENDIX D. REFERENCE REPORT



SUMMARY OF TEST RESULT

Report Section	FCC Rule	Description	Limit	Result	Remark
3.4	§2.1046	Conducted Output Power	Reporting Only	PASS	-
	§27.50(d)(4)	Equivalent Isotropic Radiated Power (Band 66)	EIRP < 1Watt	PASS	-
3.5	N/A	Peak-to-Average Ratio	<13 dB	PASS	-
3.6	§2.1049	Occupied Bandwidth	Reporting Only	PASS	-
3.7	§2.1051 §27.53(h)	Conducted Band Edge Measurement (Band 66)	< 43+10log ₁₀ (P[Watts])	PASS	-
3.8	§2.1051 §27.53(h)	Conducted Spurious Emission (Band 66)	< 43+10log ₁₀ (P[Watts])	PASS	-
4.4	§2.1053 §27.53(h)	Radiated Spurious Emission (Band 66)	< 43+10log ₁₀ (P[Watts])	PASS	Under limit 32.85 dB at 3471.00 MHz

Declaration of Conformity:

The test results with all measurement uncertainty excluded are presented in accordance with the regulation limits or requirements declared by manufacturers.

Comments and Explanations:

The declared of product specification for EUT presented in the report are provided by the manufacturer, and the manufacturer takes all the responsibilities for the accuracy of product specification.



1 General Description

1.1 Applicant

Motorola Mobility LLC
222 W,Merchandise Mart Plaza, Chicago IL 60654 USA

1.2 Manufacturer

Motorola Mobility LLC
222 W,Merchandise Mart Plaza, Chicago IL 60654 USA

1.3 Product Feature of Equipment Under Test

Product Feature	
Equipment	Mobile Cellular Phone
Brand Name	Motorola
Model Name	XT2075-1
FCC ID	IHDT56ZC1
EUT supports Radios application	GSM/WCDMA/LTE/ 5G NR WLAN 2.4GHz 802.11b/g/n HT20 WLAN 5GHz 802.11a/n HT20/HT40 WLAN 5GHz 802.11ac VHT20/VHT40/VHT80 Bluetooth BR/EDR/LE FM Receiver /GNSS/NFC
IMEI Code	Radiation: 353614110011641
HW Version	DVT2
SW Version	QPN30.37
EUT Stage	Identical Prototype

1.4 Product Specification of Equipment Under Test

Standards-related Product Specification	
Tx Frequency	LTE Band 2 : 1850.7 MHz ~ 1909.3 MHz LTE Band 4 : 1710.7 MHz ~ 1754.3 MHz LTE Band 5 : 824.7 MHz ~ 848.3 MHz LTE Band 66 : 1710.7 MHz ~ 1779.3 MHz
Rx Frequency	LTE Band 2 : 1930.7 MHz ~ 1989.3 MHz LTE Band 4 : 2110.7 MHz ~ 2154.3 MHz LTE Band 5 : 869.7 MHz ~ 893.3 MHz LTE Band 66 : 2110.7 MHz~ 2199.3 MHz
Bandwidth	LTE Band 2 : 1.4MHz / 3MHz / 5MHz / 10MHz / 15MHz / 20MHz LTE Band 4 : 1.4MHz / 3MHz / 5MHz / 10MHz / 15MHz / 20MHz LTE Band 5 : 1.4MHz / 3MHz / 5MHz / 10MHz LTE Band 66 : 1.4MHz / 3MHz / 5MHz / 10MHz / 15MHz / 20MHz
Antenna Gain	LTE Band 66 : -1.00 dBi
Type of Modulation	QPSK / 16QAM / 64QAM

Note:

Only the additional CA_66B/66C are full tested, all the other test results are data re-use from original report FG051103-02B

1.5 Modification of EUT

No modifications are made to the EUT during all test items.

1.6 Specification of Accessory

Specification of Accessory				
AC Adapter 1	Brand Name	Motorola(Chenyang)	Model Name	MC-201
AC Adapter 2	Brand Name	Motorola(Acbel)	Model Name	MC-201
Battery	Brand Name	Motorola(Amperex)	Model Name	LZ50
USB Cable 1	Brand Name	Motorola(Luxshare)	Model Name	SC18C24368
USB Cable 2	Brand Name	Motorola(Saibao)	Model Name	SC18C24367



1.7 Re-use of Measured Data

1.7.1 Introduction Section

This application re-uses data collected on a similar device. The subject device of this application (Model: XT2075-1, FCC ID: IHDT56ZC1) is electrically identical to the reference device (Model: XT2075-2, FCC ID: IHDT56ZC2) for the portions of the circuitry corresponding to the data being re-used, as treated by KDB Publication 484596 D01.

1.7.2 Difference Section

For details concerning the similarity with respect to component placement, mechanical/electrical design etc., please refer to the Product Equality Declaration.

The re-used RF data includes the following bands provided in Appendix D (Sporton RF Report No. FG051103-02B for the reference device Model: XT2075-2, FCC ID: IHDT56ZC2).

1.7.3 Reference detail Section:

Equipment Class	Reference FCC ID	Report Number	Report Title/Section
PCE (LTE)	IHDT56ZC2	Part22H.24E.27L (Report No. FG051103-02B)	All sections applicable for LTE Band 2/4/5/66 and CA_5B

1.7.4 Spot Check Verification Data Section

In order to confirm hardware similarity of the subject device with the reference device, spot check measurements were performed on the subject device for the following test items, the test result were consistent with FCC ID: IHDT56ZC2.

Assertions concerning the similarity of these devices are based on representations by the applicant. The applicant accepts full responsibility for the validity of the similarity claim, and for the determination that verification test data are sufficient to support it.

Test Item	Mode	IHDT56ZC2 Worst Result	IHDT56ZC1 Worst Result	Difference (dB)
Radiated Spurious Emission (dBm)	CA_5B	-60.91	-62.21	1.3
	LTE Band 5	-62.06	-62.9	0.84
	LTE Band 66	-49.33	-49.59	0.26



1.8 Maximum ERP/EIRP Power, Frequency Tolerance, and Emission Designator

LTE Band 66C_CA	QPSK			16QAM		
BW (MHz)	Emission Designator (99%OBW)	Frequency Tolerance (ppm)	Maximum EIRP(W)	Emission Designator (99%OBW)	Frequency Tolerance (ppm)	Maximum EIRP(W)
20MHz+20MHz	37M9G7D	-	0.1706	37M9W7D	-	0.1130
LTE Band 66C_CA	64QAM					
BW (MHz)	Emission Designator (99%OBW)	Frequency Tolerance (ppm)		Maximum EIRP(W)		
20MHz+20MHz	37M6W7D	-		0.0916		

LTE Band 66B_CA	QPSK			16QAM		
BW (MHz)	Emission Designator (99%OBW)	Frequency Tolerance (ppm)	Maximum EIRP(W)	Emission Designator (99%OBW)	Frequency Tolerance (ppm)	Maximum EIRP(W)
15MHz+5MHz	18M2G7D	-	0.1581	18M3W7D	-	0.1102
LTE Band 66B_CA	64QAM					
BW (MHz)	Emission Designator (99%OBW)	Frequency Tolerance (ppm)		Maximum EIRP(W)		
15MHz+5MHz	18M3W7D	-		0.0895		

Note: The maximum CA bandwidth has the maximum power, only the maximum EIRP is shown in the report.



1.9 Testing Location

Sporton International (Kunshan) Inc. is accredited to ISO/IEC 17025:2017 by American Association for Laboratory Accreditation with Certificate Number 5145.02.

Test Firm	Sporton International (Kunshan) Inc.		
Test Site Location	No. 1098, Pengxi North Road, Kunshan Economic Development Zone Jiangsu Province 215300 People's Republic of China TEL : +86-512-57900158 FAX : +86-512-57900958		
Test Site No.	Sporton Site No.	FCC Designation No.	FCC Test Firm Registration No.
	03CH04-KS TH01-KS	CN1257	314309

1.10 Test Software

Item	Site	Manufacture	Name	Version
1.	03CH04-KS	AUDIX	E3	6.2009-8-24a

1.11 Applicable Standards

According to the specifications of the manufacturer, the EUT must comply with the requirements of the following standards:

- 47 CFR Part 2, 22(H), 24(E), 27(L)
- ANSI C63.26-2015
- FCC KDB 971168 D01 Power Meas License Digital Systems v03r01
- FCC KDB 412172 D01 Determining ERP and EIRP v01r01

Remark:

1. All test items were verified and recorded according to the standards and without any deviation during the test.
2. This EUT has also been tested and complied with the requirements of FCC Part 15, Subpart B, recorded in a separate test report.



2 Test Configuration of Equipment Under Test

2.1 Test Mode

Antenna port conducted and radiated test items listed below are performed according to KDB 971168 D01 Power Meas License Digital Systems v03r01 with maximum output power.

Radiated measurements are performed by rotating the EUT in three different orthogonal test planes to find the maximum emission.

Test Items	Band	Bandwidth (MHz)										Modulation			RB #			Test Channel					
		20+20	20+15	15+20	20+10	10+20	20+5	5+20	15+15	15+10	10+15	QPSK	16QAM	64QAM	1	Half	Full	L	M	H			
Max. Output Power	66C_CA	v	v	v	v	v	v	v	v	v	v	v	v	v	v	v	v	v	v	v	v		
26dB and 99% Bandwidth	66C_CA	v	v	v	v	v	v	v	v	v	v	v	v	v	v			v	v	v	v		
Conducted Band Edge	66C_CA	v	v	v	v	v	v	v	v	v	v	v	v	v	v		v	v			v		
Conducted Spurious Emission	66C_CA	v	v	v	v	v	v	v	v	v	v	v	v	v	v				v	v	v		
E.I.R.P.	66C_CA	v	v	v	v	v	v	v	v	v	v	v	v	v	v				v	v	v		
Radiated Spurious Emission	66C_CA	Worst Case																			v	v	v
Note	1. The mark "v" means that this configuration is chosen for testing 2. The mark "-" means that this bandwidth is not supported. 3. The device is investigated from 30MHz to 10 times of fundamental signal for radiated spurious emission test under different RB size/offset and modulations in exploratory test. Subsequently, only the worst case emissions are reported.																						



Test Items	Band	Bandwidth (MHz)						Modulation			RB #			Test Channel		
		5+5	5+10	5+15	10+10	10+5	15+5	QPSK	16QAM	64QAM	1	Half	Full	L	M	H
Max. Output Power	66B_CA	v	v	v	v	v	v	v	v	v	v	v	v	v	v	v
26dB and 99% Bandwidth	66B_CA	v	v	v	v	v	v	v	v	v			v	v	v	v
Conducted Band Edge	66B_CA	v	v	v	v	v	v	v	v	v	v		v	v		v
Conducted Spurious Emission	66B_CA	v	v	v	v	v	v	v	v	v	v			v	v	v
E.I.R.P.	66B_CA	v	v	v	v	v	v	v	v	v	v			v	v	v
Radiated Spurious Emission	66B_CA	Worst Case											v	v	v	
Note	<ol style="list-style-type: none"> The mark "v" means that this configuration is chosen for testing The mark "-" means that this bandwidth is not supported. The device is investigated from 30MHz to 10 times of fundamental signal for radiated spurious emission test under different RB size/offset and modulations in exploratory test. Subsequently, only the worst case emissions are reported. 															

2.2 Connection Diagram of Test System

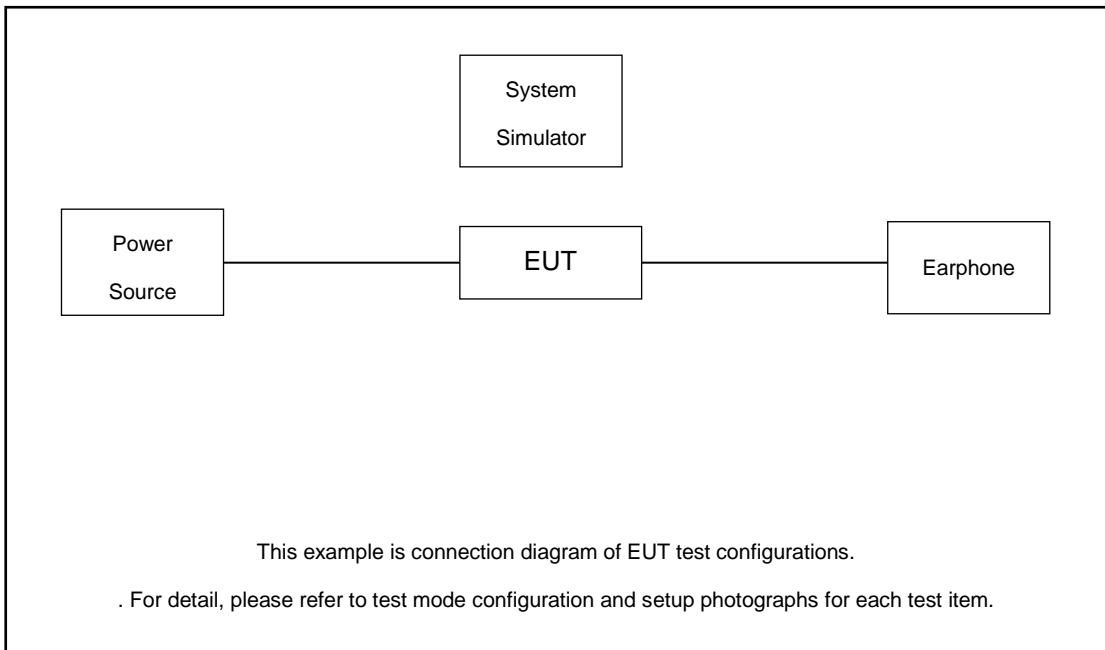

2.3 Support Unit used in test configuration and system

Item	Equipment	Trade Name	Model No.	FCC ID	Data Cable	Power Cord
1.	Power Supply	GWINSTEK	PSS-2002	N/A	N/A	Unshielded, 1.8 m
2.	LTE Base Station	Anritsu	MT8820C	N/A	N/A	Unshielded, 1.8 m

2.4 Measurement Results Explanation Example

For all conducted test items:

The offset level is set in the spectrum analyzer to compensate the RF cable loss and attenuator factor between EUT conducted output port and spectrum analyzer. With the offset compensation, the spectrum analyzer reading level is exactly the EUT RF output level.

The spectrum analyzer offset is derived from RF cable loss.

Offset = RF cable loss.

Following shows an offset computation example with cable loss 5.6 dB.

Example :

$$\begin{aligned} \text{Offset(dB)} &= \text{RF cable loss(dB)}. \\ &= 5.6 \text{ (dB)} \end{aligned}$$



2.5 Frequency List of Low/Middle/High Channels

LTE Band 66C_CA Channel and Frequency List					
BW [MHz]	Channel/Frequency(MHz)		Lowest	Middle	Highest
10 + 15	PCC	Channel	132025	132351	132477
		Frequency	1715.3	1747.9	1760.5
	SCC	Channel	132145	132471	132597
		Frequency	1727.3	1759.9	1772.5
15 + 10	PCC	Channel	132047	132373	132499
		Frequency	1717.5	1750.1	1762.7
	SCC	Channel	132167	132493	132619
		Frequency	1729.5	1762.1	1774.7
10 + 20	PCC	Channel	132027	132328	132428
		Frequency	1715.5	1745.6	1755.6
	SCC	Channel	132171	132472	132572
		Frequency	1729.9	1760	1770
20 + 10	PCC	Channel	132072	132373	132473
		Frequency	1720	1750.1	1760.1
	SCC	Channel	132216	132517	132617
		Frequency	1734.4	1764.5	1774.5
15 + 15	PCC	Channel	132047	132347	132447
		Frequency	1717.5	1747.5	1757.5
	SCC	Channel	132197	132497	132597
		Frequency	1732.5	1762.5	1772.5
15 + 20	PCC	Channel	132050	132325	132401
		Frequency	1717.8	1745.3	1752.9
	SCC	Channel	132221	132496	132572
		Frequency	1734.9	1762.4	1770
20 + 15	PCC	Channel	132072	132348	132423
		Frequency	1720	1747.6	1755.1
	SCC	Channel	132243	132519	132594
		Frequency	1737.1	1764.7	1772.2
20 + 5	PCC	Channel	132072	132397	132522
		Frequency	1720	1752.5	1765
	SCC	Channel	132189	132514	132639
		Frequency	1731.7	1764.2	1776.7



5 + 20	PCC	Channel	132005	132330	132455
		Frequency	1713.3	1745.8	1758.3
	SCC	Channel	132122	132447	132572
		Frequency	1725	1757.5	1770
20 + 20	PCC	Channel	132072	132323	132374
		Frequency	1720	1745.1	1750.2
	SCC	Channel	132270	132521	132572
		Frequency	1739.8	1764.9	1770

LTE Band 66B_CA Channel and Frequency List					
BW [MHz]	Channel/Frequency(MHz)		Lowest	Middle	Highest
5 + 5	PCC	Channel	131997	132398	132599
		Frequency	1712.5	1752.6	1772.7
	SCC	Channel	132045	132446	132647
		Frequency	1717.3	1757.4	1777.5
5 + 10	PCC	Channel	132000	132375	132550
		Frequency	1712.8	1750.3	1767.8
	SCC	Channel	132072	132447	132622
		Frequency	1720	1757.5	1775
10 + 5	PCC	Channel	132022	132397	132572
		Frequency	1715	1752.5	1770
	SCC	Channel	132094	132469	132644
		Frequency	1722.2	1759.7	1777.2
5 + 15	PCC	Channel	132002	132353	132504
		Frequency	1713	1748.1	1763.2
	SCC	Channel	132095	132446	132597
		Frequency	1722.3	1757.4	1772.5
15 + 5	PCC	Channel	132047	132398	132549
		Frequency	1717.5	1752.6	1767.7
	SCC	Channel	132140	132491	132642
		Frequency	1726.8	1761.9	1777
10 + 10	PCC	Channel	132022	132373	132523
		Frequency	1715	1750.1	1765.1
	SCC	Channel	132121	132472	132622
		Frequency	1724.9	1760	1775

3 Conducted Test Items

3.1 Measuring Instruments

See list of measuring instruments of this test report.

3.2 Test Setup

3.2.1 Conducted Output Power

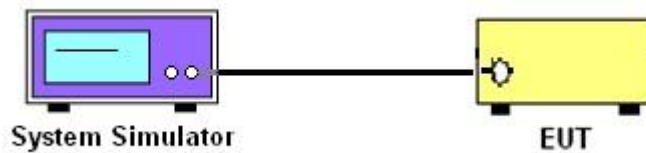

3.2.2 Peak-to-Average Ratio, Occupied Bandwidth ,Conducted Band-Edge and Conducted Spurious Emission

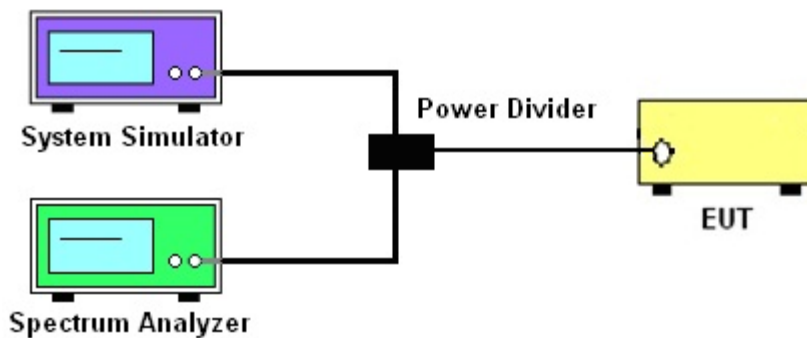

3.2.3 Frequency Stability

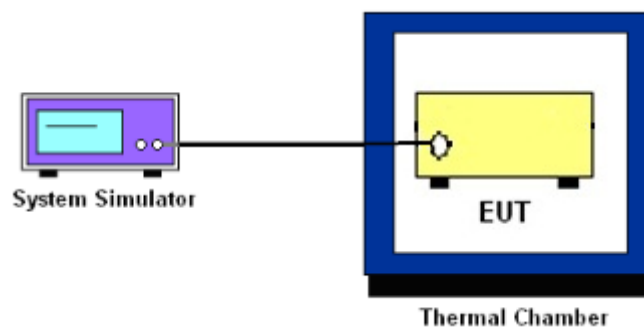

3.3 Test Result of Conducted Test

Please refer to Appendix A.



3.4 Conducted Output Power and ERP/EIRP

3.4.1 Description of the Conducted Output Power Measurement and ERP/EIRP Measurement

A system simulator was used to establish communication with the EUT. Its parameters were set to force the EUT transmitting at maximum output power. The measured power in the radio frequency on the transmitter output terminals shall be reported.

The EIRP of mobile transmitters must not exceed 1 Watts for Band 66.

According to KDB 412172 D01 Power Approach,

$EIRP = P_T + G_T - L_C$, $ERP = EIRP - 2.15$, where

P_T = transmitter output power in dBm

G_T = gain of the transmitting antenna in dBi

L_C = signal attenuation in the connecting cable between the transmitter and antenna in dB

3.4.2 Test Procedures

1. The testing follows ANSI C63.26 Section 5.2
2. The transmitter output port was connected to the system simulator.
3. Set EUT at maximum power through the system simulator.
4. Select lowest, middle, and highest channels for each band and different modulation.
5. Measure and record the power level from the system simulator.



3.5 Peak-to-Average Ratio

3.5.1 Description of the PAR Measurement

Power Complementary Cumulative Distribution Function (CCDF) curves provide a means for characterizing the power peaks of a digitally modulated signal on a statistical basis. A CCDF curve depicts the probability of the peak signal amplitude exceeding the average power level. Most contemporary measurement instrumentation include the capability to produce CCDF curves for an input signal provided that the instrument's resolution bandwidth can be set wide enough to accommodate the entire input signal bandwidth. In measuring transmissions in this band using an average power technique, the peak-to-average ratio (PAR) of the transmission may not exceed 13 dB.

3.5.2 Test Procedures

1. The testing follows ANSI C63.26 Section 5.2.3.4 (CCDF).
2. The EUT was connected to spectrum and system simulator via a power divider.
3. Set the CCDF (Complementary Cumulative Distribution Function) option in spectrum analyzer.
4. The highest RF powers were measured and recorded the maximum PAPR level associated with a probability of 0.1 %.
5. Record the deviation as Peak to Average Ratio.



3.6 Occupied Bandwidth

3.6.1 Description of Occupied Bandwidth Measurement

The occupied bandwidth is the width of a frequency band such that, below the lower and above the upper frequency limits, the mean powers emitted are each equal to a specified percentage 0.5% of the total mean transmitted power.

The 26 dB emission bandwidth is defined as the frequency range between two points, one above and one below the carrier frequency, at which the spectral density of the emission is attenuated 26 dB below the maximum in-band spectral density of the modulated signal. Spectral density (power per unit bandwidth) is to be measured with a detector of resolution bandwidth equal to approximately 1.0% of the emission bandwidth.

3.6.2 Test Procedures

1. The testing follows ANSI C63.26 Section 5.4
2. The EUT was connected to spectrum analyzer and system simulator via a power divider.
3. The spectrum analyzer center frequency is set to the nominal EUT channel center frequency. The span range for the spectrum analyzer shall be between two and five times the anticipated OBW.
4. The nominal resolution bandwidth (RBW) shall be in the range of 1 to 5 % of the anticipated OBW, and the VBW shall be at least 3 times the RBW.
5. Set the detection mode to peak, and the trace mode to max hold.
6. Determine the reference value: Set the EUT to transmit a modulated signal. Allow the trace to stabilize. Set the spectrum analyzer marker to the highest level of the displayed trace.
(this is the reference value)
7. Determine the “-26 dB down amplitude” as equal to (Reference Value – X).
8. Place two markers, one at the lowest and the other at the highest frequency of the envelope of the spectral display such that each marker is at or slightly below the “-X dB down amplitude” determined in step 6. If a marker is below this “-X dB down amplitude” value it shall be placed as close as possible to this value. The OBW is the positive frequency difference between the two markers.
9. Use the 99 % power bandwidth function of the spectrum analyzer and report the measured bandwidth.



3.7 Conducted Band Edge

3.7.1 Description of Conducted Band Edge Measurement

27.53 (h)

For operations in the 1710 – 1755 MHz band, the FCC limit is $43 + 10\log_{10}(P[\text{Watts}])$ dB below the transmitter power $P(\text{Watts})$ in a 1 MHz bandwidth. However, in the 1MHz bands immediately outside and adjacent to the licensee's frequency block, a resolution bandwidth of at least one percent of the emission bandwidth of the fundamental emission of the transmitter may be employed.

3.7.2 Test Procedures

1. The testing follows ANSI C63.26 section 5.7
2. The EUT was connected to spectrum analyzer and system simulator via a power divider.
3. The band edges of low and high channels for the highest RF powers were measured.
4. Set RBW $\geq 1\%$ EBW in the 1MHz band immediately outside and adjacent to the band edge.
5. Beyond the 1 MHz band from the band edge, RBW=1MHz was used.
6. Set spectrum analyzer with RMS detector.
7. The RF fundamental frequency should be excluded against the limit line in the operating frequency band.
8. Checked that all the results comply with the emission limit line.

Example:

The limit line is derived from $43 + 10\log(P)\text{dB}$ below the transmitter power $P(\text{Watts})$
 $= P(\text{W}) - [43 + 10\log(P)] (\text{dB})$
 $= [30 + 10\log(P)] (\text{dBm}) - [43 + 10\log(P)] (\text{dB}) = -13\text{dBm}.$



3.8 Conducted Spurious Emission

3.8.1 Description of Conducted Spurious Emission Measurement

The power of any emission outside of the authorized operating frequency ranges must be lower than the transmitter power (P) by a factor of at least $43 + 10 \log (P)$ dB.

It is measured by means of a calibrated spectrum analyzer and scanned from 30 MHz up to a frequency including its 10th harmonic.

3.8.2 Test Procedures

1. The testing follows ANSI C63.26 section 5.7
2. The EUT was connected to spectrum analyzer and system simulator via a power divider.
3. The RF output of EUT was connected to the spectrum analyzer by RF cable and attenuator. The path loss was compensated to the results for each measurement.
4. The middle channel for the highest RF power within the transmitting frequency was measured.
5. The conducted spurious emission for the whole frequency range was taken.
6. Make the measurement with the spectrum analyzer's RBW = 1MHz, VBW = 3MHz.
7. Set spectrum analyzer with RMS detector.
8. Taking the record of maximum spurious emission.
9. The RF fundamental frequency should be excluded against the limit line in the operating frequency band.
10. The limit line is derived from $43 + 10\log(P)$ dB below the transmitter power P(Watts)
= P(W)- [43 + 10log(P)] (dB)
= [30 + 10log(P)] (dBm) - [43 + 10log(P)] (dB)
= -13dBm.

4 Radiated Test Items

4.1 Measuring Instruments

See list of measuring instruments of this test report.

4.2 Test Setup

4.2.1 For radiated test from 30MHz to 1GHz

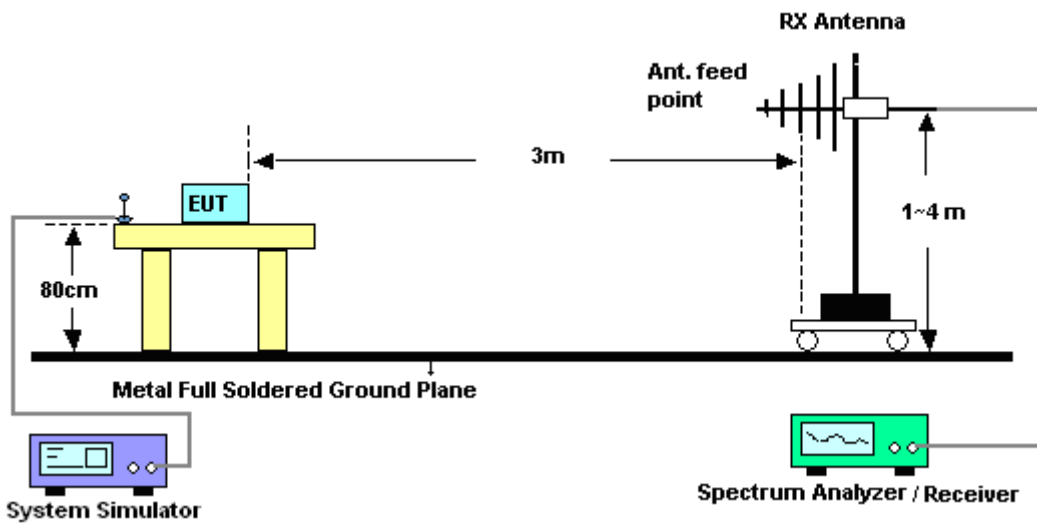

4.2.2 For radiated test above 1GHz

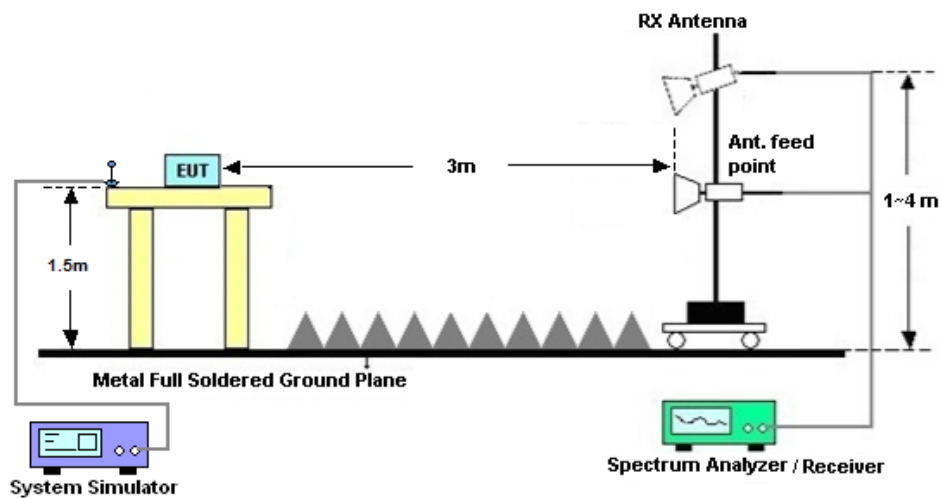

4.3 Test Result of Radiated Test

Please refer to Appendix B.



4.4 Radiated Spurious Emission

4.4.1 Description of Radiated Spurious Emission

The radiated spurious emission was measured by substitution method according to ANSI C63.26. The power of any emission outside of the authorized operating frequency ranges must be attenuated below the transmitter power (P) by a factor of at least $43 + 10 \log (P)$ dB.

The spectrum is scanned from 30 MHz up to a frequency including its 10th harmonic.

4.4.2 Test Procedures

1. The testing follows ANSI C63.26 Section 5.5
2. The EUT was placed on a turntable with 0.8 meter height for frequency below 1GHz and 1.5 meter height for frequency above 1GHz respectively above ground.
3. The EUT was set 3 meters from the receiving antenna mounted on the antenna tower.
4. The table was rotated 360 degrees to determine the position of the highest spurious emission.
5. The height of the receiving antenna is varied between 1m to 4m to search the maximum spurious emission for both horizontal and vertical polarizations.
6. During the measurement, the system simulator parameters were set to force the EUT transmitting at maximum output power.
7. Make the measurement with the spectrum analyzer's RBW = 1MHz, VBW = 3MHz, taking the record of maximum spurious emission.
8. A horn antenna was substituted in place of the EUT and was driven by a signal generator.
9. Tune the output power of signal generator to the same emission level with EUT maximum spurious emission.
10. $EIRP \text{ (dBm)} = S.G. \text{ Power} - Tx \text{ Cable Loss} + Tx \text{ Antenna Gain}$
11. $ERP \text{ (dBm)} = EIRP - 2.15$
12. The RF fundamental frequency should be excluded against the limit line in the operating frequency band.

The limit line is derived from $43 + 10\log(P)$ dB below the transmitter power P(Watts)
= $P(W) - [43 + 10\log(P)] \text{ (dB)}$
= $[30 + 10\log(P)] \text{ (dBm)} - [43 + 10\log(P)] \text{ (dB)}$
= -13dBm.



5 List of Measuring Equipment

Instrument	Manufacturer	Model No.	Serial No.	Characteristics	Calibration Date	Test Date	Due Date	Remark
Spectrum Analyzer	R&S	FSV40	101040	10Hz~40GHz	Nov. 02, 2019	Jun. 25, 2020~ Jul. 01, 2020	Nov. 01, 2020	Conducted (TH01-KS)
Thermal Chamber	Ten Billion	TTC-B3S	TBN-960502	-40~+150°C	Oct. 28, 2019	Jun. 25, 2020~ Jul. 01, 2020	Oct. 27, 2020	Conducted (TH01-KS)
EXA Spectrum Analyzer	Keysight	N9010A	MY55150244	10Hz-44G,MAX 30dB	Apr. 15, 2020	Jun. 08, 2020~ Jul. 27, 2020	Apr. 14, 2021	Radiation (03CH04-KS)
Bilog Antenna	TeseQ	CBL6111D	49922	30MHz-1GHz	Jun. 08, 2020	Jun. 08, 2020~ Jul. 27, 2020	Jun. 07, 2021	Radiation (03CH04-KS)
Horn Antenna	Schwarzbeck	BBHA9120D	1356	1GHz~18GHz	Apr. 20, 2020	Jun. 08, 2020~ Jul. 27, 2020	Apr. 19, 2021	Radiation (03CH04-KS)
SHF-EHF Horn	Com-power	AH-840	101115	18GHz~40GHz	Nov. 10, 2019	Jun. 08, 2020~ Jul. 27, 2020	Nov. 09, 2020	Radiation (03CH04-KS)
Amplifier	SONOMA	310N	187289	9KHz-1GHz	Aug. 06, 2019	Jun. 08, 2020~ Jul. 27, 2020	Aug. 05, 2020	Radiation (03CH04-KS)
Amplifier	MITEQ	EM18G40G GA	060728	18~40GHz	Jan. 08, 2020	Jun. 08, 2020~ Jul. 27, 2020	Jan. 07, 2021	Radiation (03CH04-KS)
high gain Amplifier	MITEQ	AMF-7D-00 101800-30-1 0P	2025788	1Ghz-18Ghz	Aug. 16, 2019	Jun. 08, 2020~ Jul. 27, 2020	Aug. 15, 2020	Radiation (03CH04-KS)
Amplifier	Keysight	83017A	MY57280106	500MHz~26.5GHz	Oct. 15, 2019	Jun. 08, 2020~ Jul. 27, 2020	Oct. 14, 2020	Radiation (03CH04-KS)
AC Power Source	Chroma	61601	F104090004	N/A	NCR	Jun. 08, 2020~ Jul. 27, 2020	NCR	Radiation (03CH04-KS)
Turn Table	ChamPro	EM 1000-T	060762-T	0~360 degree	NCR	Jun. 08, 2020~ Jul. 27, 2020	NCR	Radiation (03CH04-KS)
Antenna Mast	ChamPro	EM 1000-A	060762-A	1 m~4 m	NCR	Jun. 08, 2020~ Jul. 27, 2020	NCR	Radiation (03CH04-KS)

NCR: No Calibration Required



6 Uncertainty of Evaluation

The measurement uncertainties shown below were calculated in accordance with the requirements of ANSI 63.26-2015. All the measurement uncertainty value were shown with a coverage K=2 to indicate 95% level of confidence. The measurement data show herein meets or exceeds the CISPR measurement uncertainty values specified in CISPR 16-4-2 and can be compared directly to specified limit to determine compliance.

Uncertainty of Radiated Emission Measurement (30 MHz ~ 1000 MHz)

Measuring Uncertainty for a Level of Confidence of 95% (U = 2Uc(y))	3.3dB
---	-------

Uncertainty of Radiated Emission Measurement (1 GHz ~ 40 GHz)

Measuring Uncertainty for a Level of Confidence of 95% (U = 2Uc(y))	2.8dB
---	-------



Appendix A. Test Results of Conducted Test

Conducted Output Power(Average power)

CA Power

Bottom Antenna:

CA_66C								
Combination 20MHz+20MHz (100RB+100RB)								
PCC Channel	SCC Channel	Modulation	PCC		SCC		Total RB Size	Measured Power (dBm)
			RB Size	RB offset	RB Size	RB offset		
132072	132270	QPSK	1	99	1	0	1	23.28
132322	132124	QPSK	1	0	1	99	1	23.23
132572	132374	QPSK	1	0	1	99	1	23.32
132072	132270	16QAM	1	99	1	0	1	21.42
132322	132124	16QAM	1	0	1	99	1	21.32
132572	132374	16QAM	1	0	1	99	1	21.53
132072	132270	64QAM	1	99	1	0	1	20.62
132322	132124	64QAM	1	0	1	99	1	20.52
132572	132374	64QAM	1	0	1	99	1	20.42

CA_66B								
Combination 15MHz+5MHz (75RB+25RB)								
PCC Channel	SCC Channel	Modulation	PCC		SCC		Total RB Size	Measured Power (dBm)
			RB Size	RB offset	RB Size	RB offset		
132047	132140	QPSK	1	74	1	0	1	22.98
132322	132229	QPSK	1	0	1	24	1	22.99
132597	132504	QPSK	1	0	1	24	1	22.83
132047	132140	16QAM	1	74	1	0	1	21.32
132322	132229	16QAM	1	0	1	24	1	21.33
132597	132504	16QAM	1	0	1	24	1	21.42
132047	132140	64QAM	1	74	1	0	1	20.52
132322	132229	64QAM	1	0	1	24	1	20.23
132597	132504	64QAM	1	0	1	24	1	20.31



CA EIRP

Bottom Antenna:

LTE Band 66C_CA (GT - LC = -1.00 dB) QPSK			
Bandwidth	20M + 20M		
Channel PCC	132005	132330	132455
	(Low)	(Mid)	(High)
Channel SCC	132122	132447	132572
	(Low)	(Mid)	(High)
Conducted Power (dBm)	23.28	23.23	23.32
Conducted Power (Watts)	0.2128	0.2104	0.2148
EIRP(dBm)	22.28	22.23	22.32
EIRP(Watts)	0.1690	0.1671	0.1706

LTE Band 66C_CA (GT - LC = -1.00 dB) 16QAM			
Bandwidth	20M + 20M		
Channel PCC	132005	132330	132455
	(Low)	(Mid)	(High)
Channel SCC	132122	132447	132572
	(Low)	(Mid)	(High)
Conducted Power (dBm)	21.42	21.32	21.53
Conducted Power (Watts)	0.1387	0.1355	0.1422
EIRP(dBm)	20.42	20.32	20.53
EIRP(Watts)	0.1102	0.1076	0.1130



LTE Band 66C_CA (GT - LC = -1.00 dB) 64QAM			
Bandwidth	20M + 20M		
Channel PCC	132005	132330	132455
	(Low)	(Mid)	(High)
Channel SCC	132122	132447	132572
	(Low)	(Mid)	(High)
Conducted Power (dBm)	20.62	20.52	20.42
Conducted Power (Watts)	0.1153	0.1127	0.1102
EIRP(dBm)	19.62	19.52	19.42
EIRP(Watts)	0.0916	0.0895	0.0875



LTE Band 66B_CA (GT - LC = -1.00 dB) QPSK			
Bandwidth	15M+5M		
Channel PCC	132047	132398	132549
	(Low)	(Mid)	(High)
Channel SCC	132140	132491	132642
	(Low)	(Mid)	(High)
Conducted Power (dBm)	22.98	22.99	22.83
Conducted Power (Watts)	0.1986	0.1991	0.1919
EIRP(dBm)	21.98	21.99	21.83
EIRP(Watts)	0.1578	0.1581	0.1524

LTE Band 66B_CA (GT - LC = -1.00 dB) 16QAM			
Bandwidth	15M+5M		
Channel PCC	132047	132398	132549
	(Low)	(Mid)	(High)
Channel SCC	132140	132491	132642
	(Low)	(Mid)	(High)
Conducted Power (dBm)	21.32	21.33	21.42
Conducted Power (Watts)	0.1355	0.1358	0.1387
EIRP(dBm)	20.32	20.33	20.42
EIRP(Watts)	0.1076	0.1079	0.1102



LTE Band 66B_CA (GT - LC = -1.00 dB) 64QAM			
Bandwidth	15M+5M		
Channel PCC	132047	132398	132549
	(Low)	(Mid)	(High)
Channel SCC	132140	132491	132642
	(Low)	(Mid)	(High)
Conducted Power (dBm)	20.52	20.23	20.31
Conducted Power (Watts)	0.1127	0.1054	0.1074
EIRP(dBm)	19.52	19.23	19.31
EIRP(Watts)	0.0895	0.0838	0.0853



LTE Band 66C_CA

26dB Bandwidth

Mode	LTE Band 66C : 26dB BW(MHz)				
QPSK					
BW	5MHz+20MHz	10MHz+15MHz	10MHz+20MHz	15MHz+10MHz	15MHz+15MHz
Lowest CH	24.73	25.13	29.79	25.13	30.51
Middle CH	24.78	25.13	29.97	25.23	30.63
Highest CH	24.78	25.08	29.73	25.28	30.45
BW	15MHz+20MHz	20MHz+5MHz	20MHz+10MHz	20MHz+15MHz	20MHz+20MHz
Lowest CH	34.97	25.03	30.09	35.11	39.80
Middle CH	34.76	25.03	30.09	34.90	39.72
Highest CH	34.69	25.13	29.91	36.01	39.80

Mode	LTE Band 66C : 26dB BW(MHz)				
16QAM					
BW	5MHz+20MHz	10MHz+15MHz	10MHz+20MHz	15MHz+10MHz	15MHz+15MHz
Lowest CH	24.83	25.08	29.85	25.08	30.51
Middle CH	24.83	25.18	29.85	25.13	30.45
Highest CH	24.63	25.18	29.91	25.18	30.39
BW	15MHz+20MHz	20MHz+5MHz	20MHz+10MHz	20MHz+15MHz	20MHz+20MHz
Lowest CH	34.83	24.98	29.97	35.04	39.96
Middle CH	34.76	24.98	30.09	34.83	39.80
Highest CH	34.83	24.98	30.21	35.18	39.72

Mode	LTE Band 66C : 26dB BW(MHz)				
64QAM					
BW	5MHz+20MHz	10MHz+15MHz	10MHz+20MHz	15MHz+10MHz	15MHz+15MHz
Lowest CH	24.73	25.18	29.73	25.23	30.39
Middle CH	24.73	25.03	29.85	25.23	30.51
Highest CH	24.78	25.13	29.85	25.13	30.39
BW	15MHz+20MHz	20MHz+5MHz	20MHz+10MHz	20MHz+15MHz	20MHz+20MHz
Lowest CH	34.76	25.03	30.15	34.76	39.80
Middle CH	34.76	24.93	29.97	34.83	39.64
Highest CH	34.90	25.08	29.91	34.76	39.88



LTE Band 66C

QPSK

Lowest Channel / 5MHz+20MHz

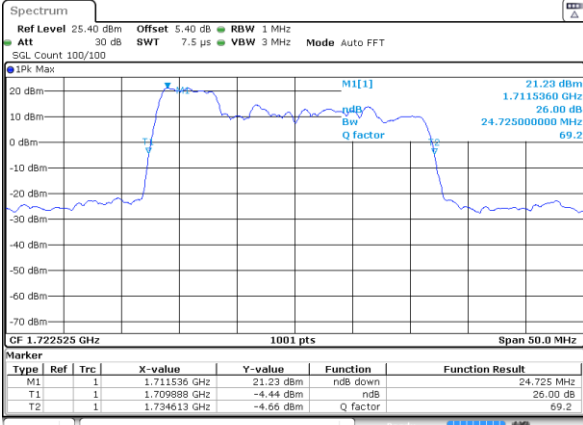

Date: 29 JUN 2020 22:10:32

Lowest Channel / 10MHz+15MHz

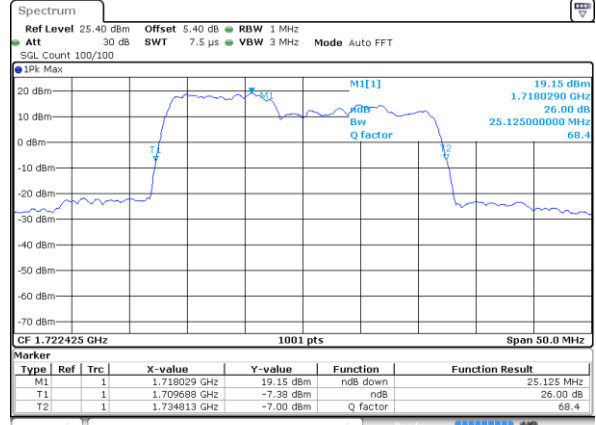

Date: 29 JUN 2020 19:48:34

Middle Channel / 5MHz+20MHz

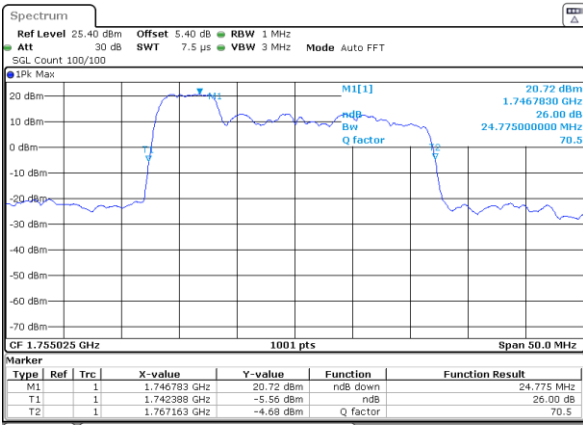

Date: 29 JUN 2020 22:36:22

Middle Channel / 10MHz+15MHz

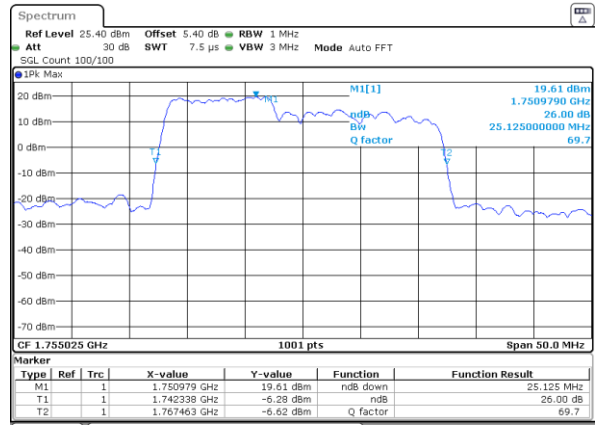

Date: 29 JUN 2020 20:15:53

Highest Channel / 5MHz+20MHz

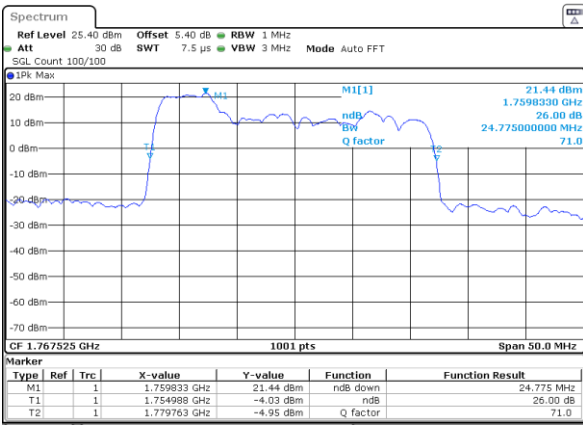

Date: 29 JUN 2020 22:39:51

Highest Channel / 10MHz+15MHz

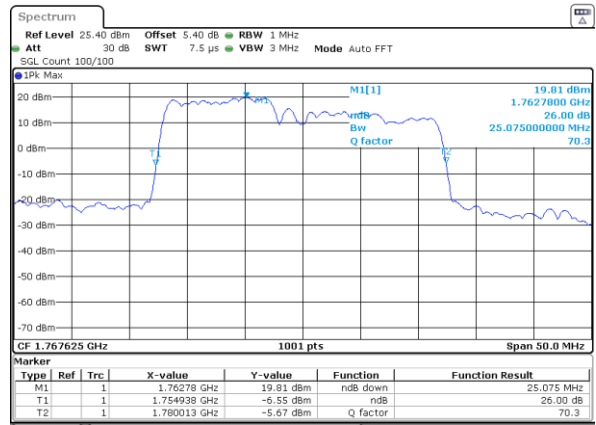

Date: 29 JUN 2020 20:23:39



LTE Band 66C

QPSK

Lowest Channel / 10MHz+20MHz

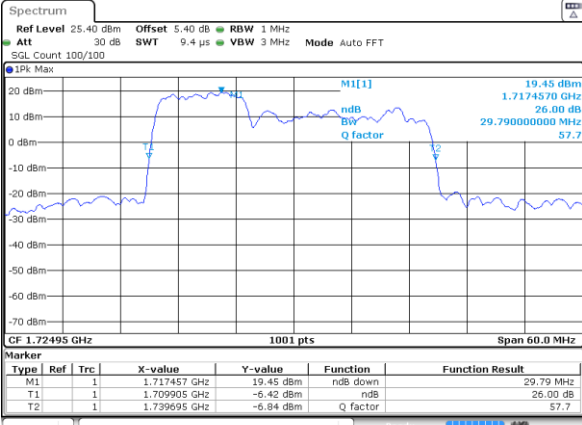

Date: 29 JUN 2020 23 06 12

Lowest Channel / 15MHz+10MHz

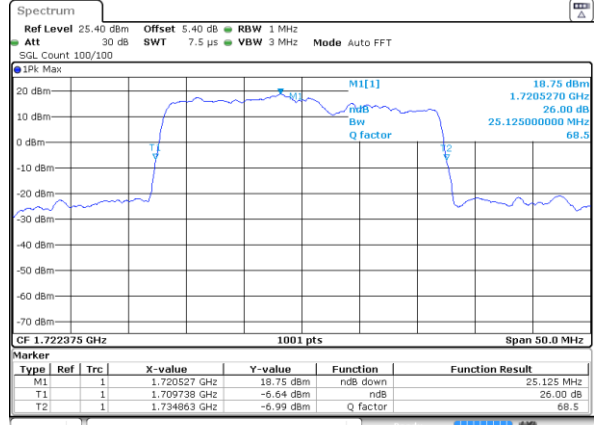

Date: 29 JUN 2020 20 30 53

Middle Channel / 10MHz+20MHz

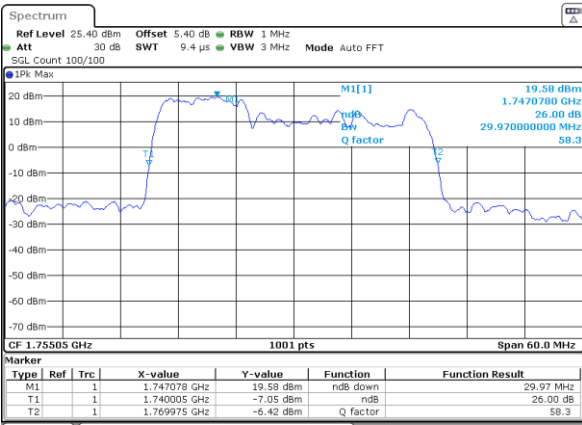

Date: 29 JUN 2020 23 22 48

Middle Channel / 15MHz+10MHz

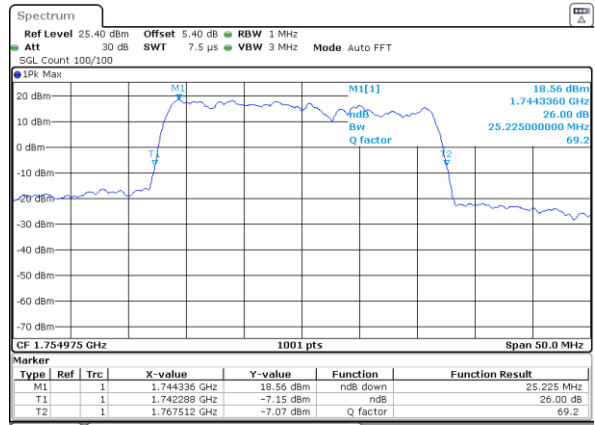

Date: 29 JUN 2020 20 42 08

Highest Channel / 10MHz+20MHz

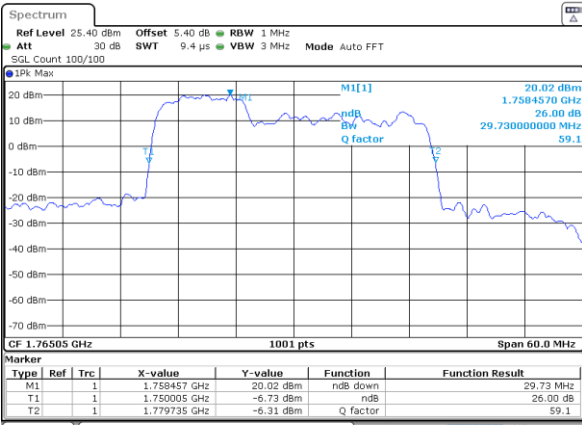

Date: 29 JUN 2020 23 29 59

Highest Channel / 15MHz+10MHz

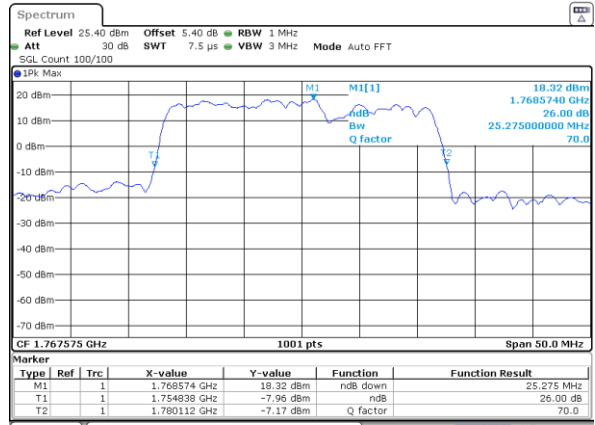

Date: 29 JUN 2020 20 47 34



LTE Band 66C

QPSK

Lowest Channel / 15MHz+15MHz

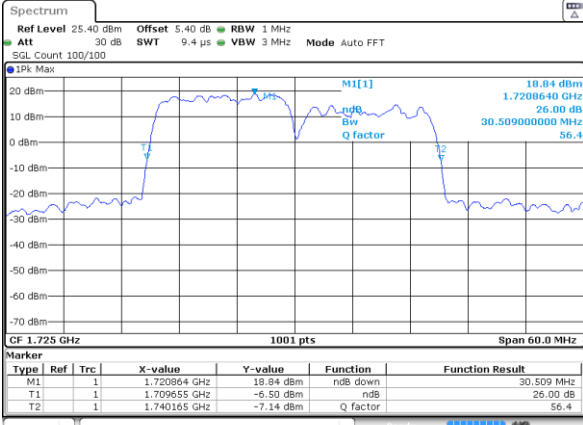

Date: 30 JUN 2020 00:07:11

Lowest Channel / 15MHz+20MHz

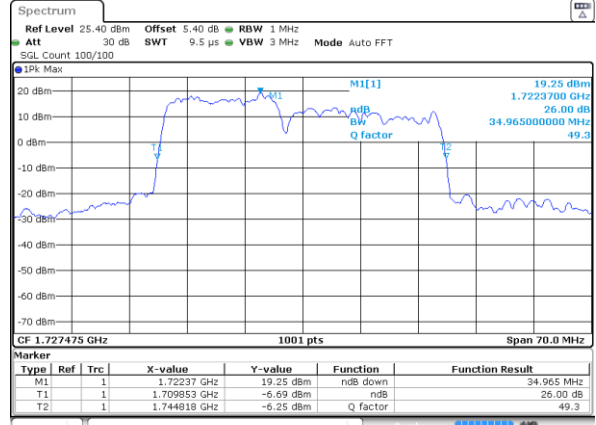

Date: 30 JUN 2020 00:40:02

Middle Channel / 15MHz+15MHz

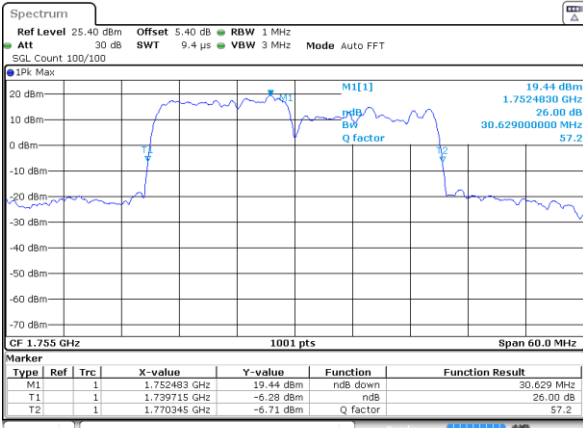

Date: 30 JUN 2020 00:22:05

Middle Channel / 15MHz+20MHz

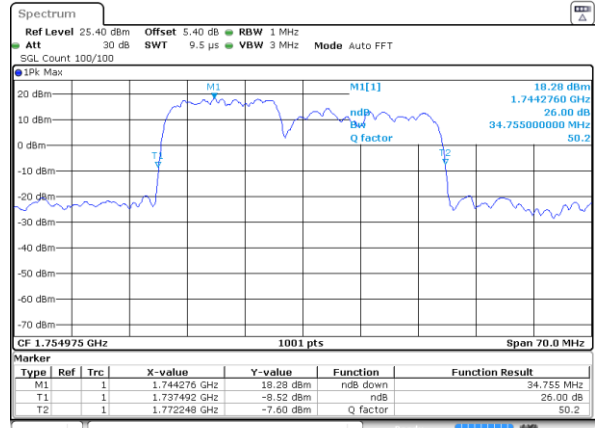

Date: 30 JUN 2020 00:54:18

Highest Channel / 15MHz+15MHz

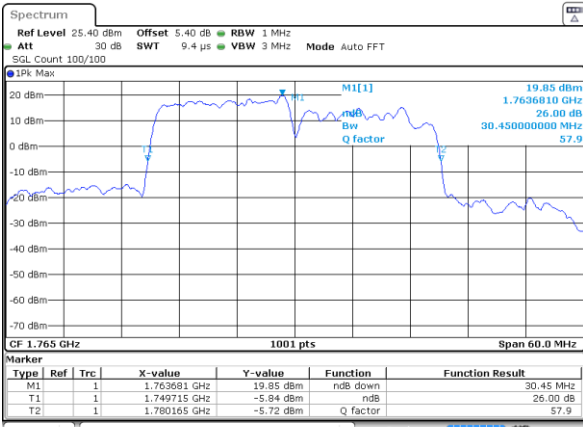

Date: 30 JUN 2020 00:36:38

Highest Channel / 15MHz+20MHz

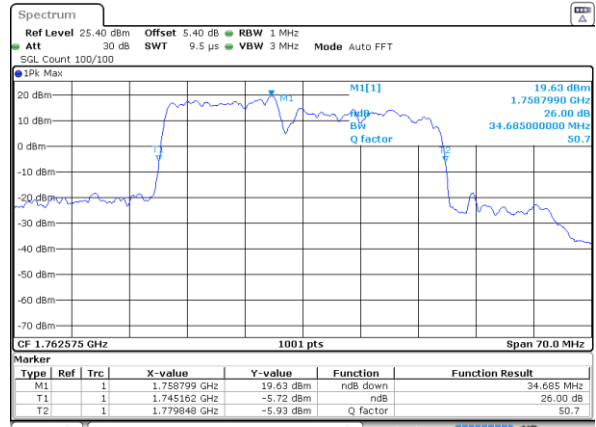

Date: 30 JUN 2020 00:55:22



LTE Band 66C

QPSK

Lowest Channel / 20MHz+5MHz

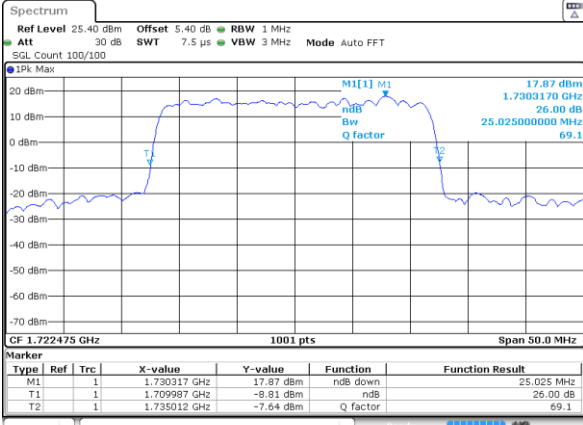

Date: 30 JUN 2020 02:02:53

Lowest Channel / 20MHz+10MHz

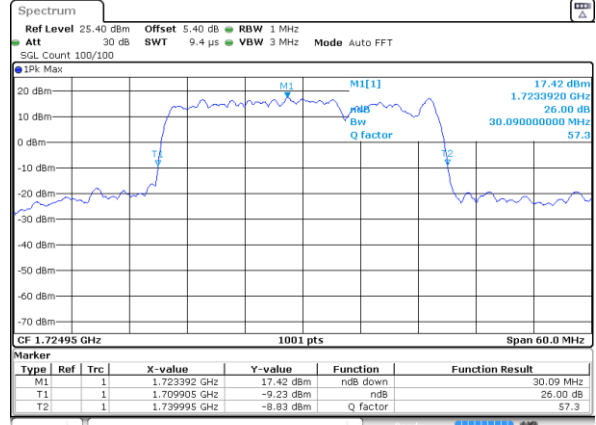

Date: 30 JUN 2020 03:06:38

Middle Channel / 20MHz+5MHz

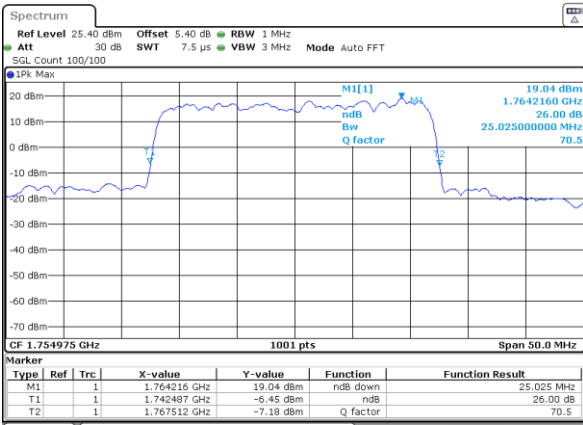

Date: 30 JUN 2020 02:18:52

Middle Channel / 20MHz+10MHz

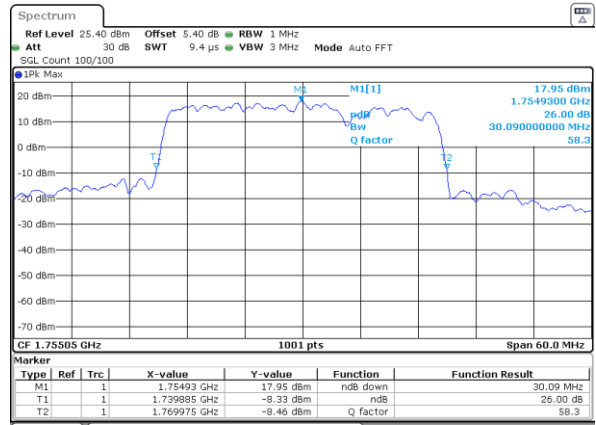

Date: 30 JUN 2020 03:23:59

Highest Channel / 20MHz+5MHz

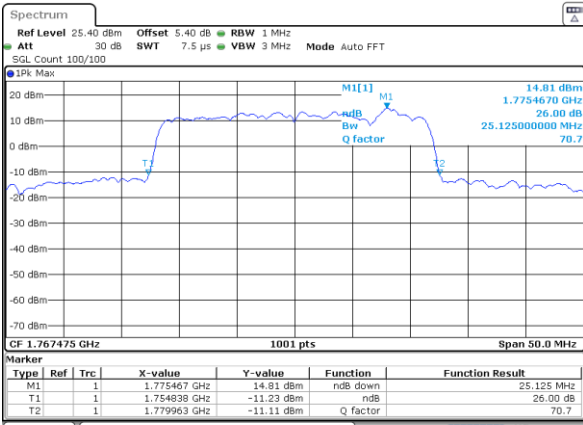

Date: 30 JUN 2020 02:24:49

Highest Channel / 20MHz+10MHz

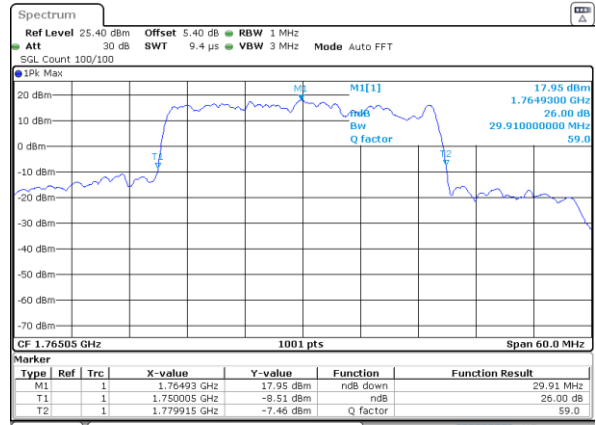

Date: 30 JUN 2020 03:33:57



LTE Band 66C

QPSK

Lowest Channel / 20MHz+15MHz

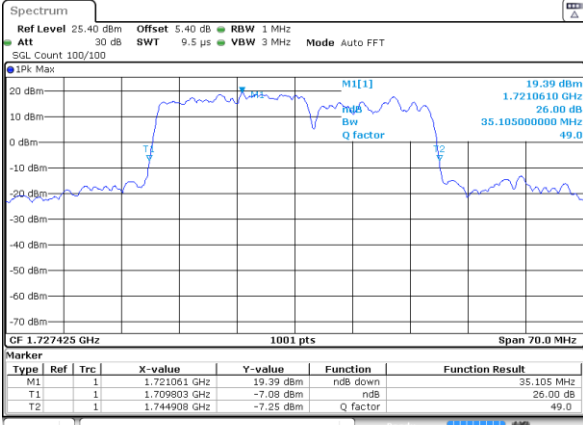

Date: 30 JUN 2020 03:55:28

Lowest Channel / 20MHz+20MHz

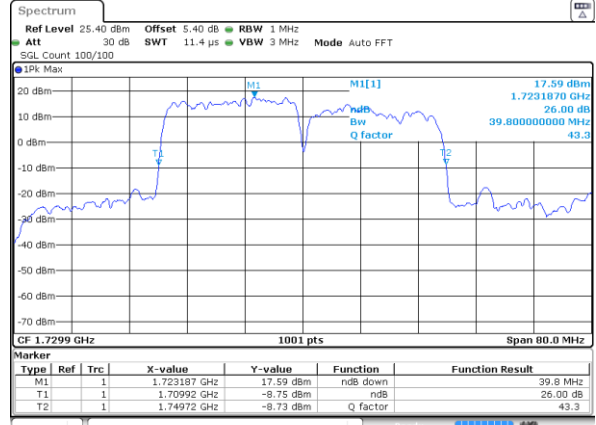

Date: 30 JUN 2020 04:42:49

Middle Channel / 20MHz+15MHz

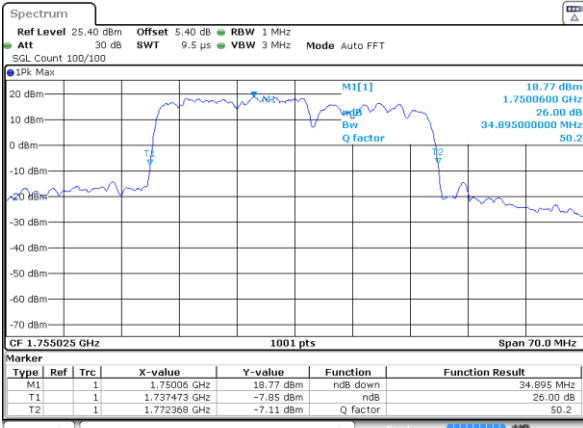

Date: 30 JUN 2020 04:10:15

Middle Channel / 20MHz+20MHz

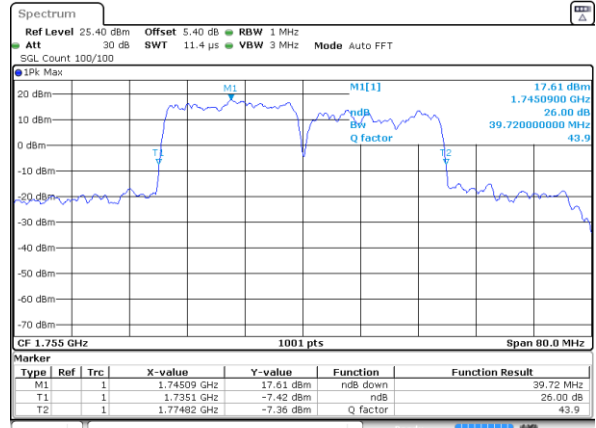

Date: 30 JUN 2020 05:21:54

Highest Channel / 20MHz+15MHz

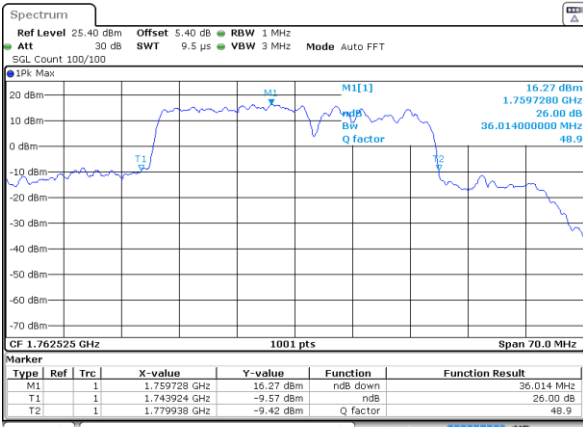

Date: 30 JUN 2020 04:24:05

Highest Channel / 20MHz+20MHz

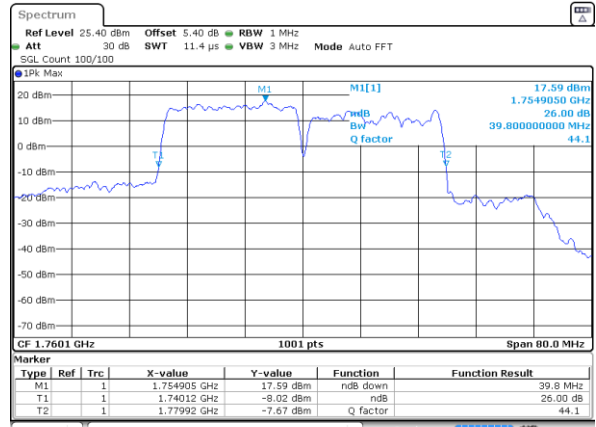

Date: 30 JUN 2020 05:30:51



LTE Band 66C

16QAM

Lowest Channel / 5MHz+20MHz

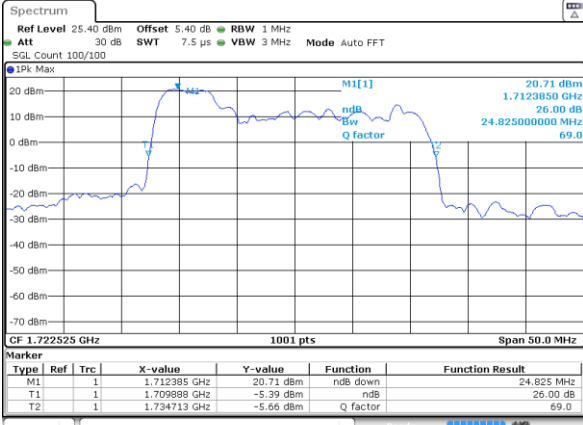

Date: 29 JUN 2020 22:12:16

Lowest Channel / 10MHz+15MHz

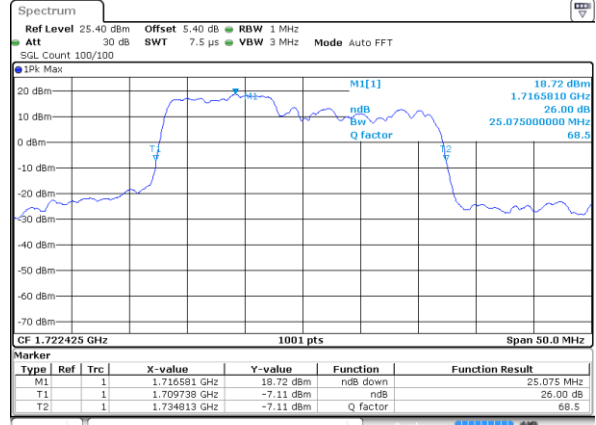

Date: 29 JUN 2020 19:50:34

Middle Channel / 5MHz+20MHz

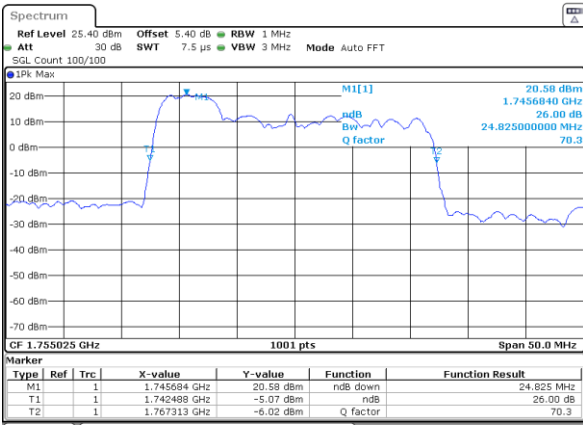

Date: 29 JUN 2020 22:36:48

Middle Channel / 10MHz+15MHz

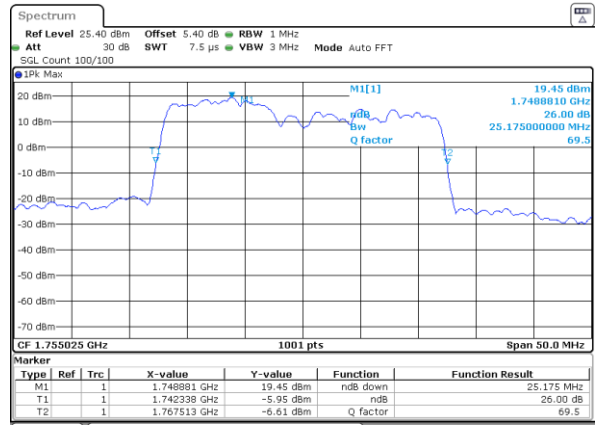

Date: 29 JUN 2020 20:17

Highest Channel / 5MHz+20MHz

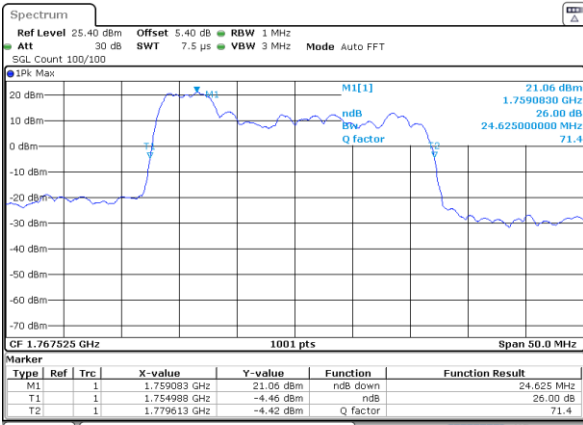

Date: 29 JUN 2020 22:40:53

Highest Channel / 10MHz+15MHz

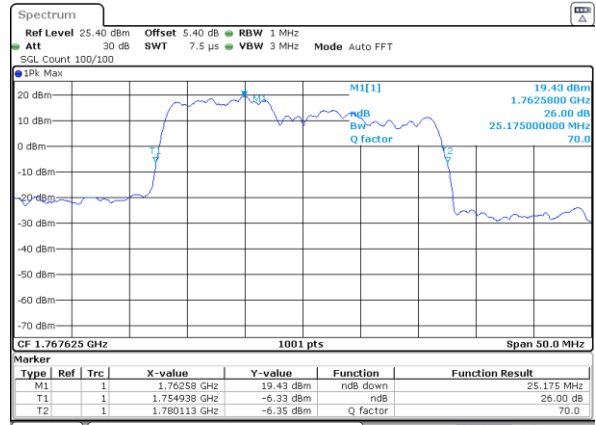

Date: 29 JUN 2020 20:22:48



LTE Band 66C

16QAM

Lowest Channel / 10MHz+20MHz

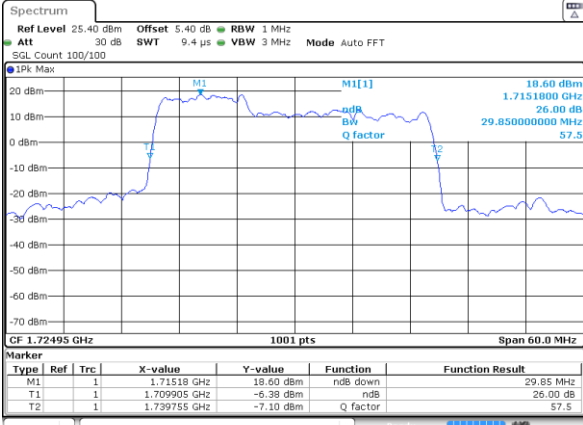

Date: 29 JUN 2020 23:07:52

Lowest Channel / 15MHz+10MHz

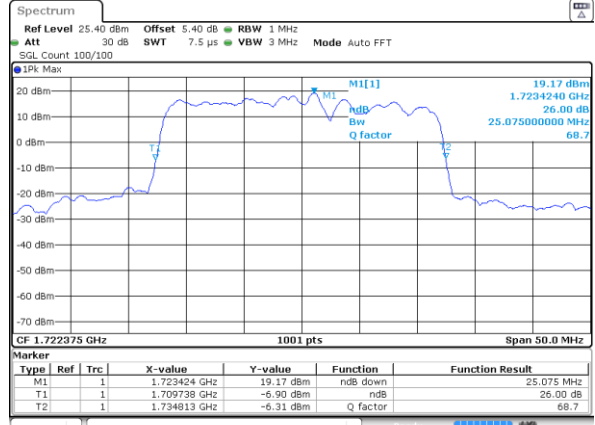

Date: 29 JUN 2020 20:31:42

Middle Channel / 10MHz+20MHz

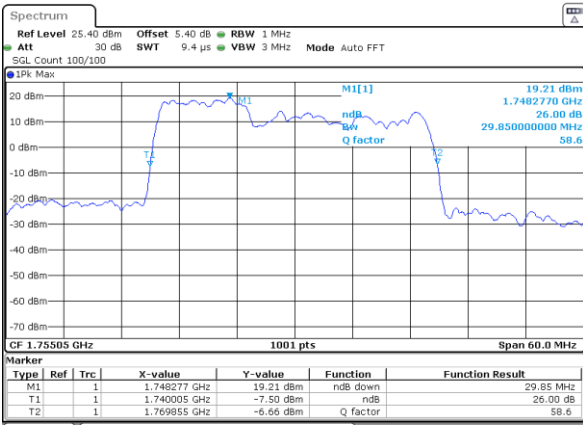

Date: 29 JUN 2020 23:21:49

Middle Channel / 15MHz+10MHz

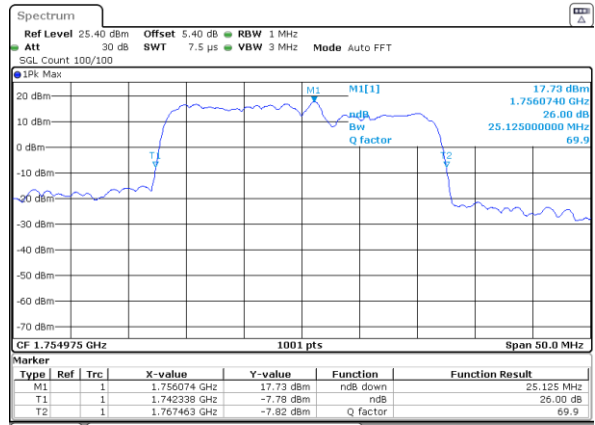

Date: 29 JUN 2020 20:42:30

Highest Channel / 10MHz+20MHz

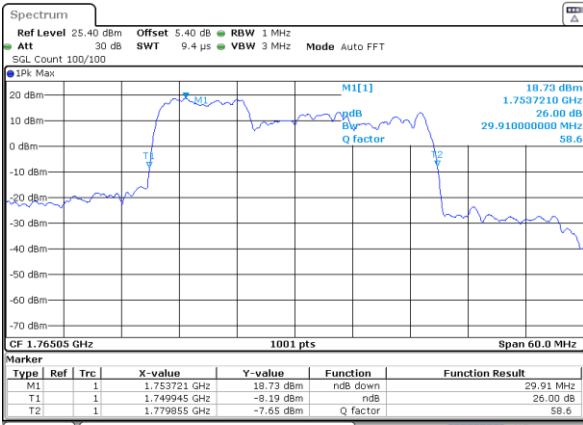

Date: 29 JUN 2020 23:30:34

Highest Channel / 15MHz+10MHz

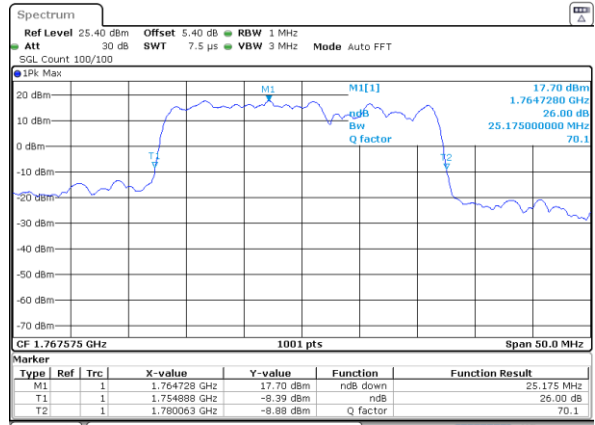

Date: 29 JUN 2020 20:44:54



LTE Band 66C

16QAM

Lowest Channel / 15MHz+15MHz

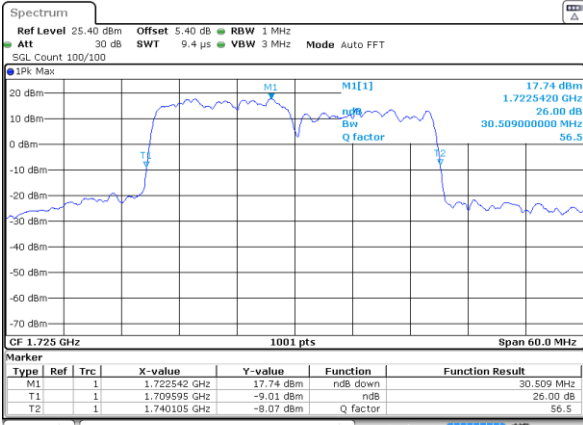

Date: 30 JUN 2020 00:08:11

Lowest Channel / 15MHz+20MHz

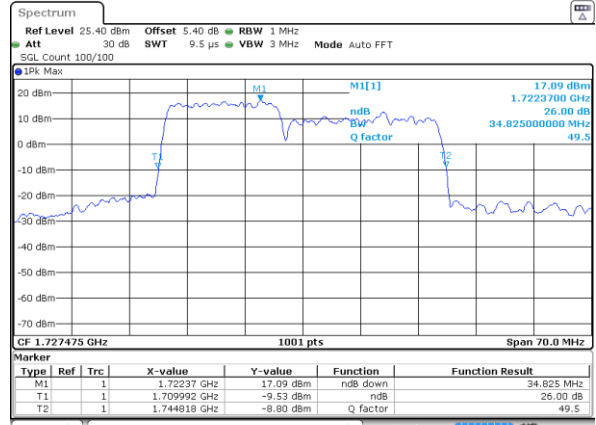

Date: 30 JUN 2020 00:41:09

Middle Channel / 15MHz+15MHz

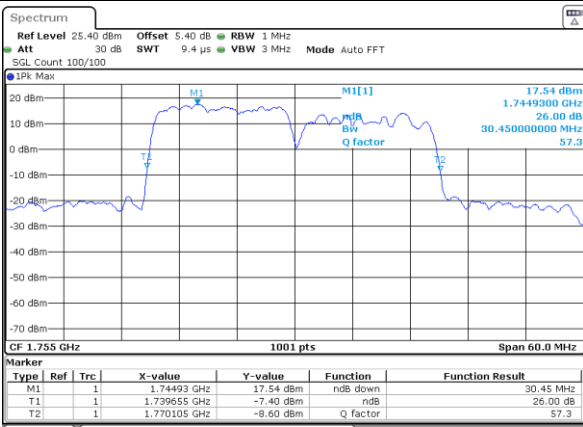

Date: 30 JUN 2020 00:22:51

Middle Channel / 15MHz+20MHz

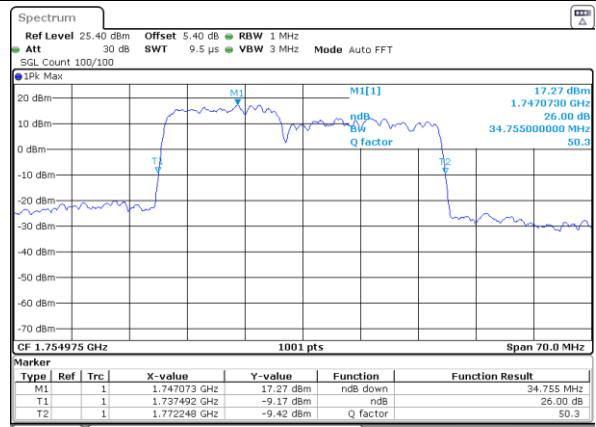

Date: 30 JUN 2020 00:53:32

Highest Channel / 15MHz+15MHz

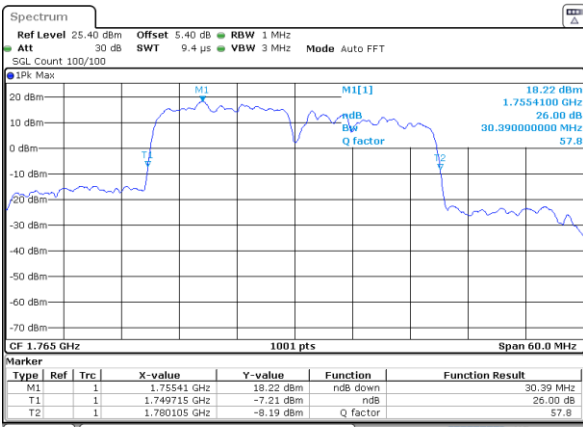

Date: 30 JUN 2020 00:37:32

Highest Channel / 15MHz+20MHz

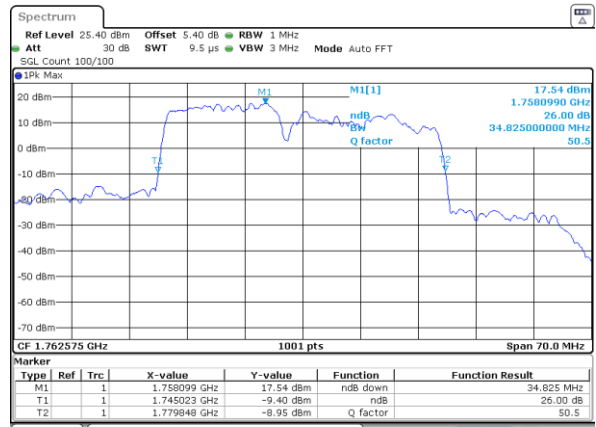

Date: 30 JUN 2020 00:56:19



LTE Band 66C

16QAM

Lowest Channel / 20MHz+5MHz

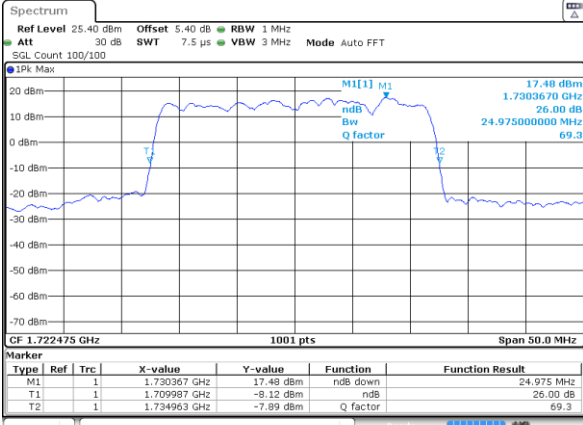

Date: 30 JUN 2020 02:04:07

Lowest Channel / 20MHz+10MHz

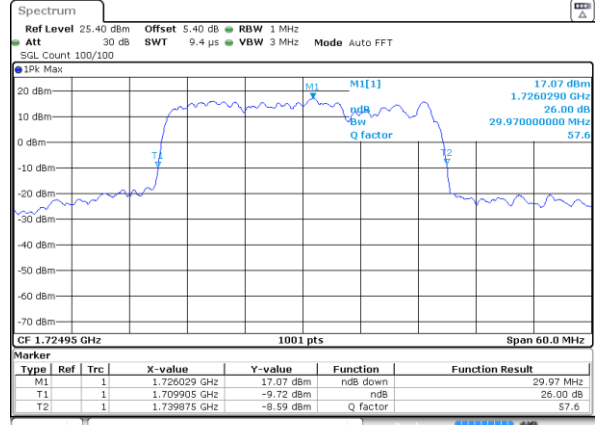

Date: 30 JUN 2020 03:07:38

Middle Channel / 20MHz+5MHz

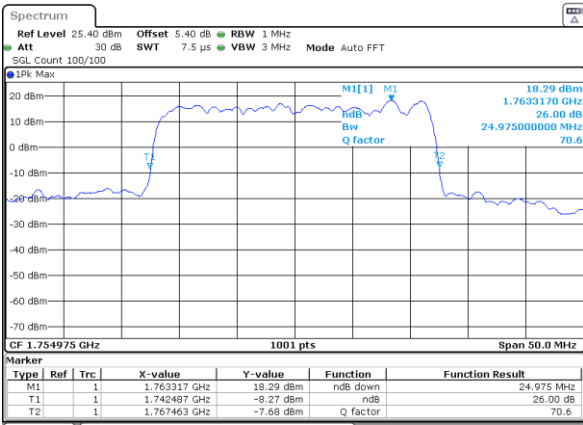

Date: 30 JUN 2020 02:19:14

Middle Channel / 20MHz+10MHz

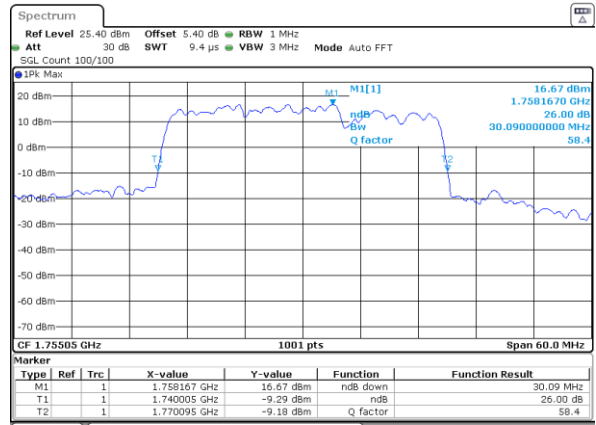

Date: 30 JUN 2020 03:24:19

Highest Channel / 20MHz+5MHz

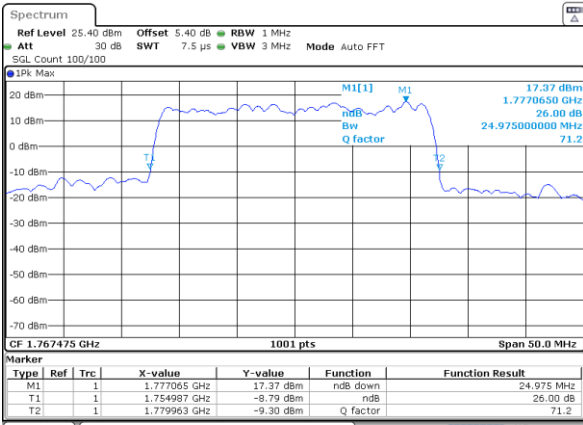

Date: 30 JUN 2020 02:21:45

Highest Channel / 20MHz+10MHz

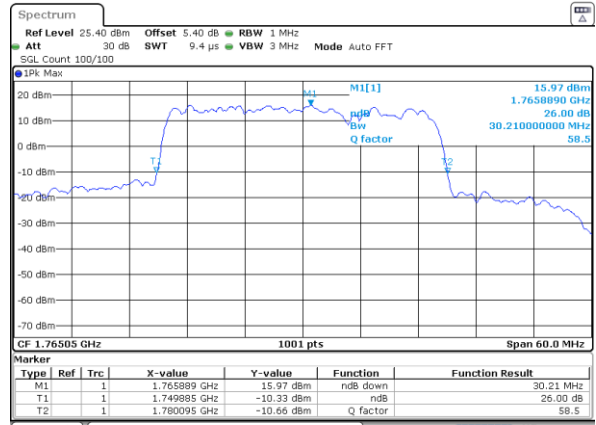

Date: 30 JUN 2020 03:32:01



LTE Band 66C

16QAM

Lowest Channel / 20MHz+15MHz

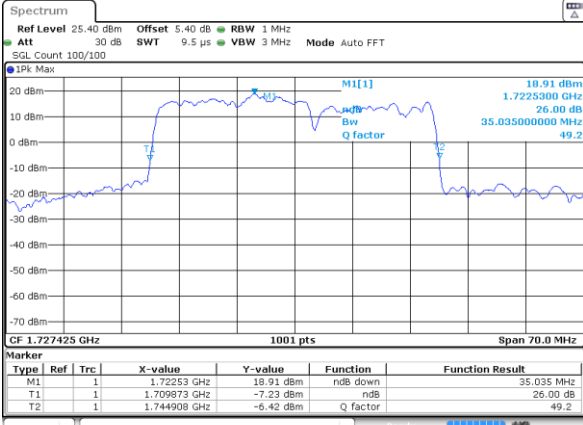

Date: 30 JUN 2020 03:56:17

Lowest Channel / 20MHz+20MHz

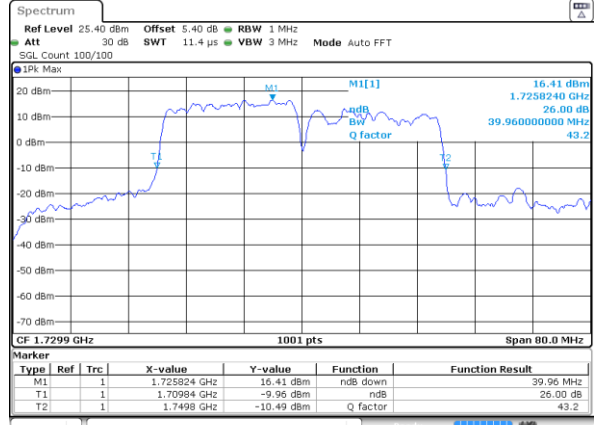

Date: 30 JUN 2020 04:43:52

Middle Channel / 20MHz+15MHz

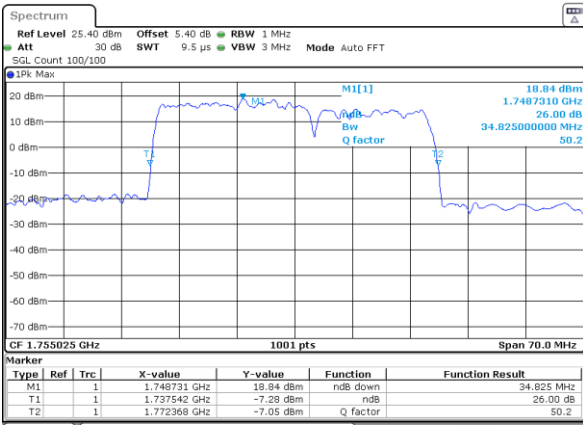

Date: 30 JUN 2020 04:10:40

Middle Channel / 20MHz+20MHz

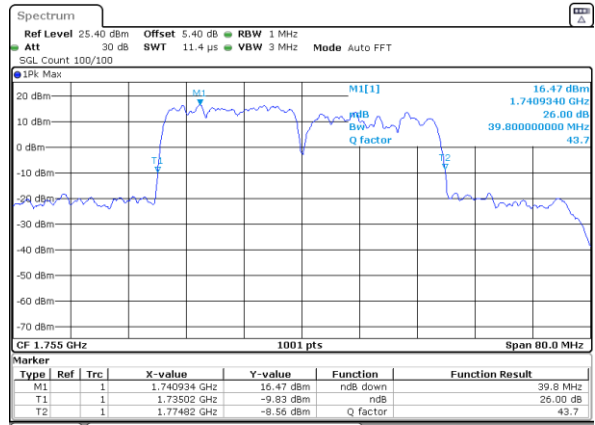

Date: 30 JUN 2020 05:22:42

Highest Channel / 20MHz+15MHz

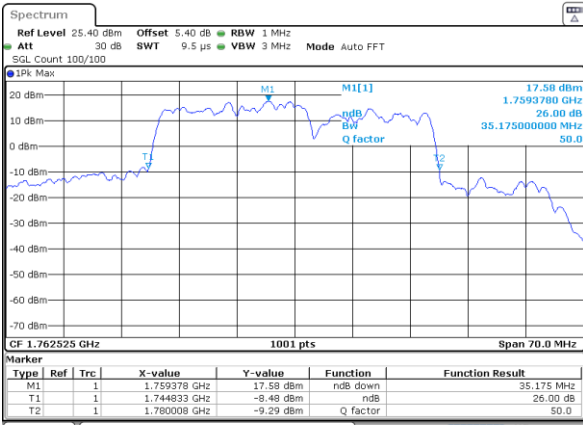

Date: 30 JUN 2020 04:13:05

Highest Channel / 20MHz+20MHz

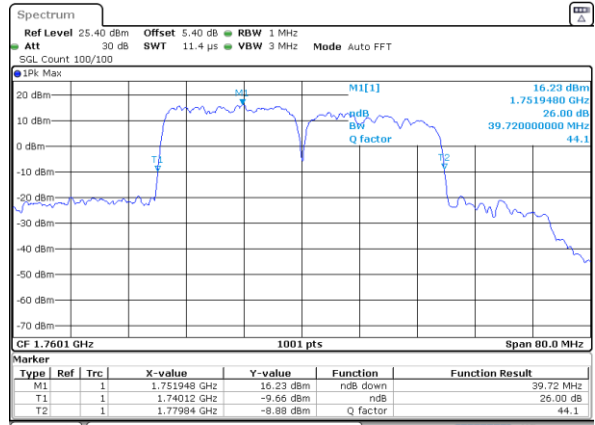

Date: 30 JUN 2020 05:31:21



LTE Band 66C

64QAM

Lowest Channel / 5MHz+20MHz

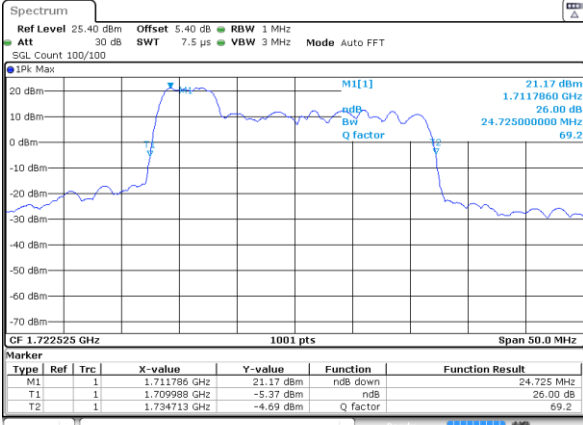

Date: 29 JUN 2020 22:13:28

Lowest Channel / 10MHz+15MHz

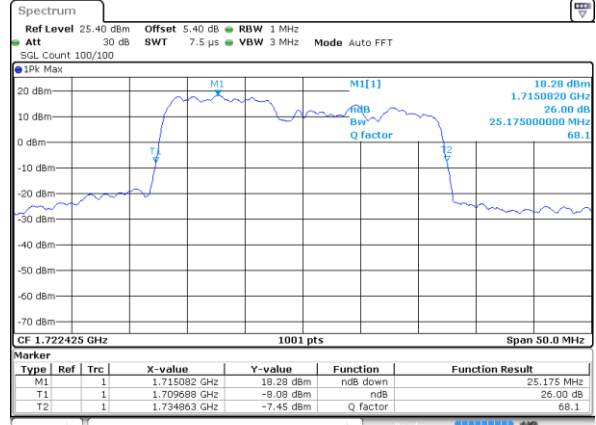

Date: 29 JUN 2020 19:51:31

Middle Channel / 5MHz+20MHz

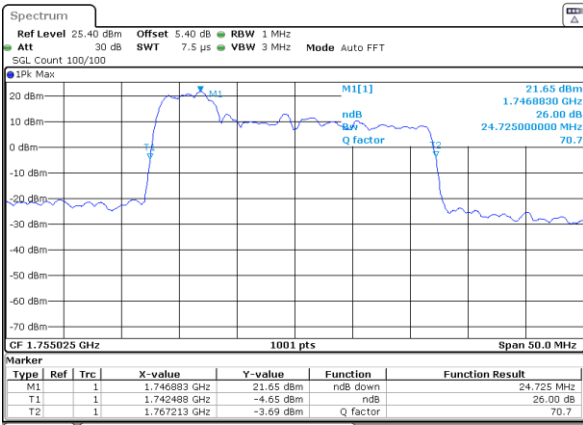

Date: 29 JUN 2020 22:37:11

Middle Channel / 10MHz+15MHz

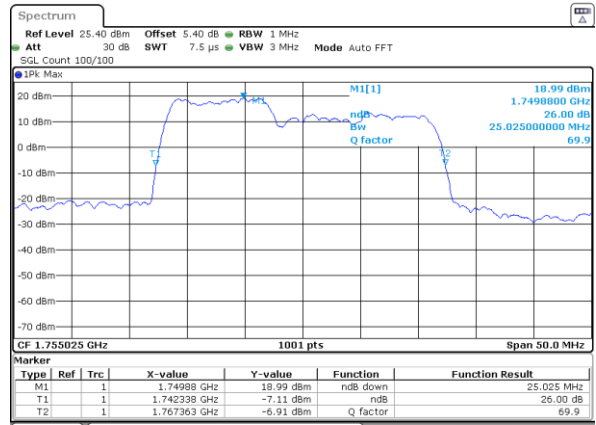

Date: 29 JUN 2020 20:24:47

Highest Channel / 5MHz+20MHz

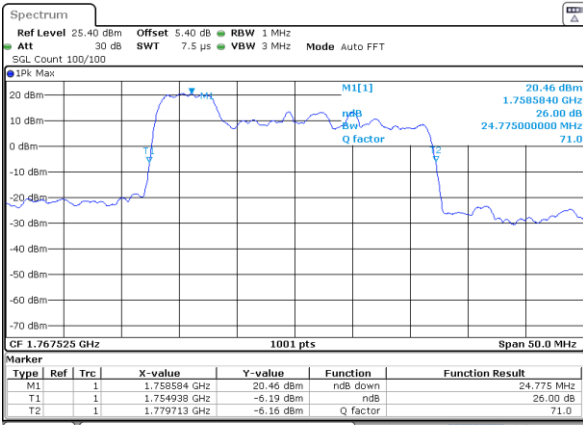

Date: 29 JUN 2020 22:38:51

Highest Channel / 10MHz+15MHz

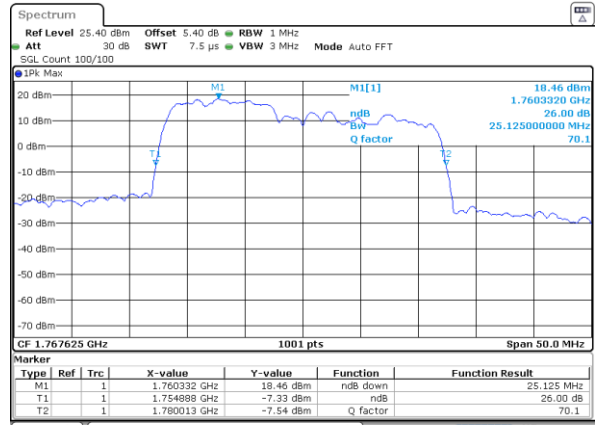

Date: 29 JUN 2020 20:21:56



LTE Band 66C

64QAM

Lowest Channel / 10MHz+20MHz

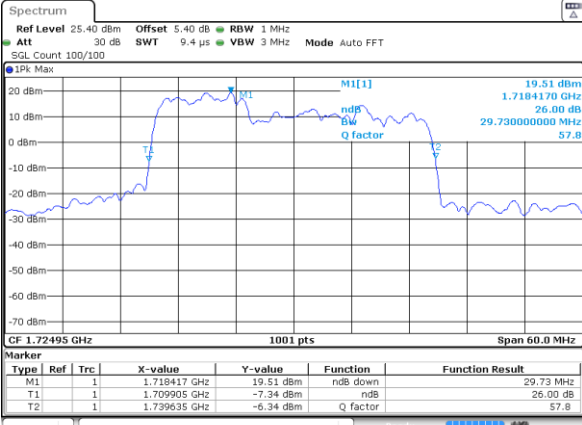

Date: 29 JUN 2020 23 06 49

Lowest Channel / 15MHz+10MHz

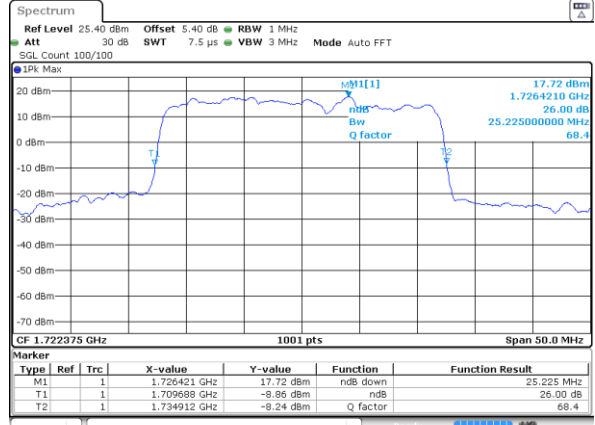

Date: 29 JUN 2020 20 32 46

Middle Channel / 10MHz+20MHz

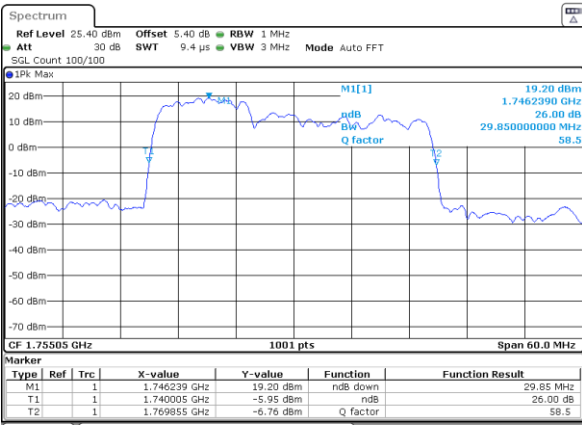

Date: 29 JUN 2020 23 22 22

Middle Channel / 15MHz+10MHz

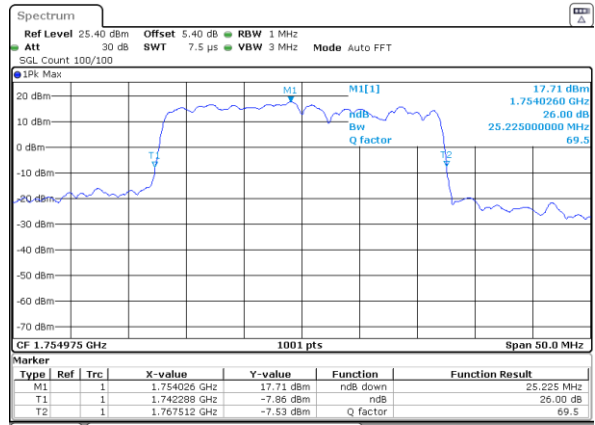

Date: 29 JUN 2020 20 32 40

Highest Channel / 10MHz+20MHz

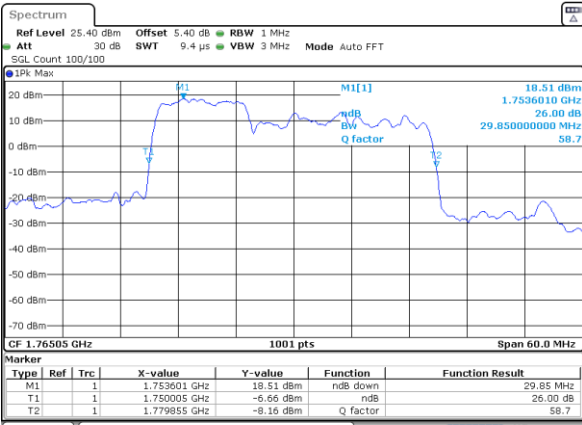

Date: 29 JUN 2020 23 28 08

Highest Channel / 15MHz+10MHz

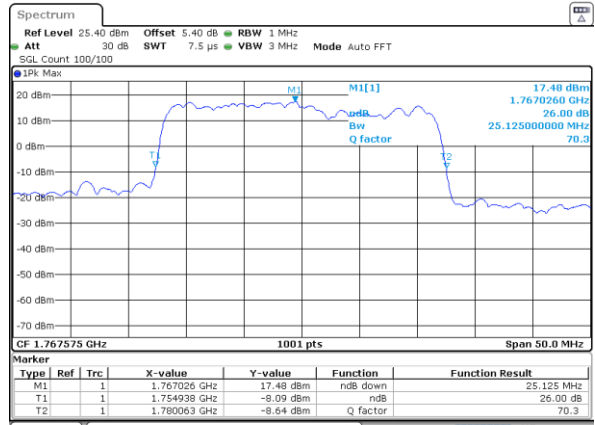

Date: 29 JUN 2020 20 46 22



LTE Band 66C

64QAM

Lowest Channel / 15MHz+15MHz

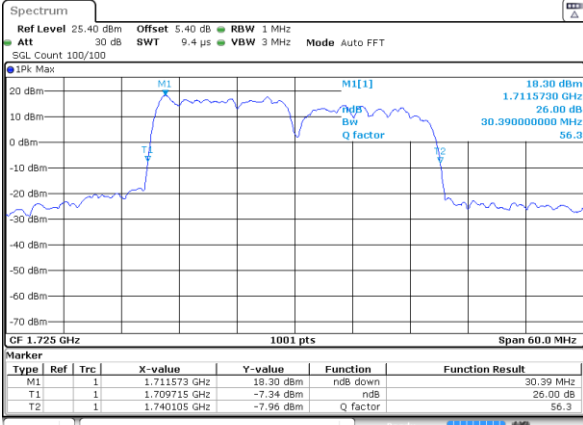

Date: 30 JUN 2020 00:09:08

Lowest Channel / 15MHz+20MHz

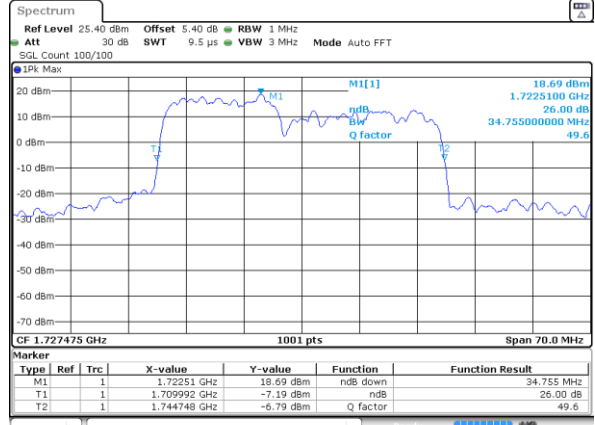

Date: 30 JUN 2020 00:42:48

Middle Channel / 15MHz+15MHz

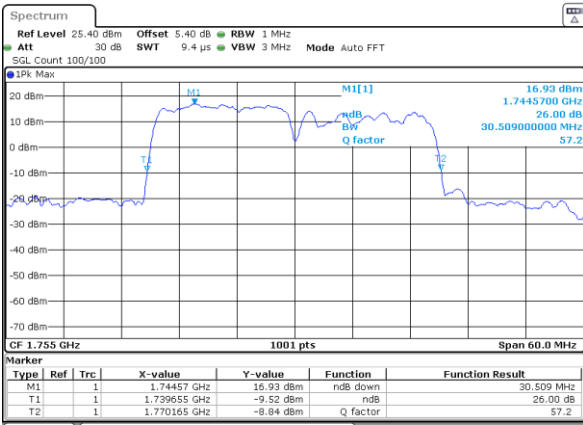

Date: 30 JUN 2020 00:21:39

Middle Channel / 15MHz+20MHz

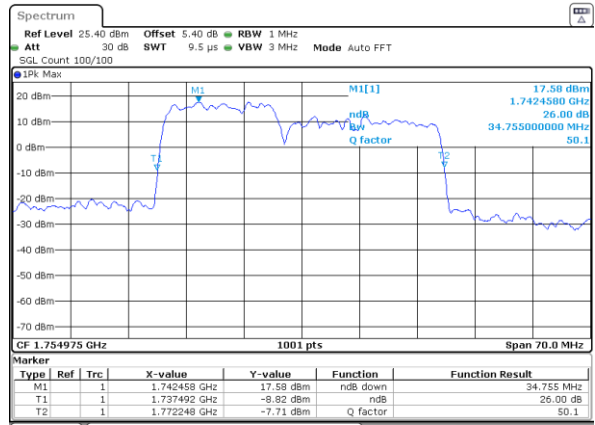

Date: 30 JUN 2020 00:53:56

Highest Channel / 15MHz+15MHz

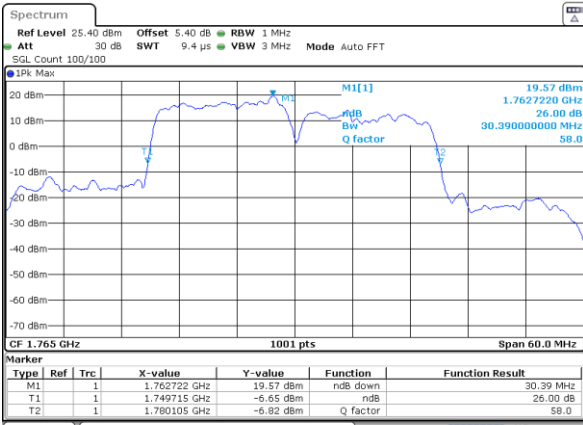

Date: 30 JUN 2020 00:35:40

Highest Channel / 15MHz+20MHz

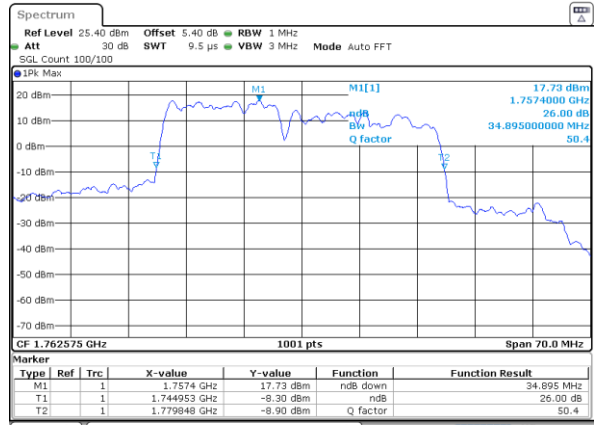

Date: 30 JUN 2020 00:57:17



LTE Band 66C

64QAM

Lowest Channel / 20MHz+5MHz

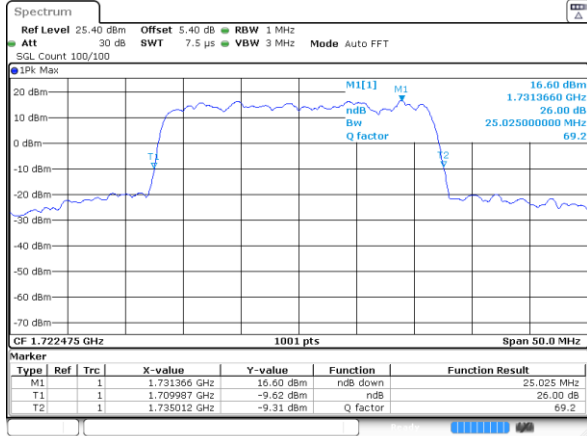

Date: 30 JUN 2020 02:04:53

Lowest Channel / 20MHz+10MHz

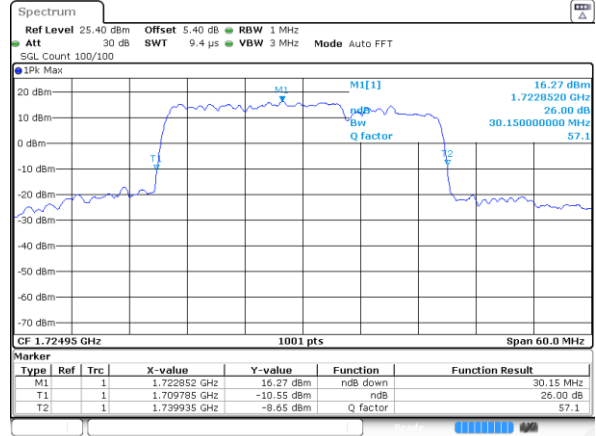

Date: 30 JUN 2020 03:08:22

Middle Channel / 20MHz+5MHz

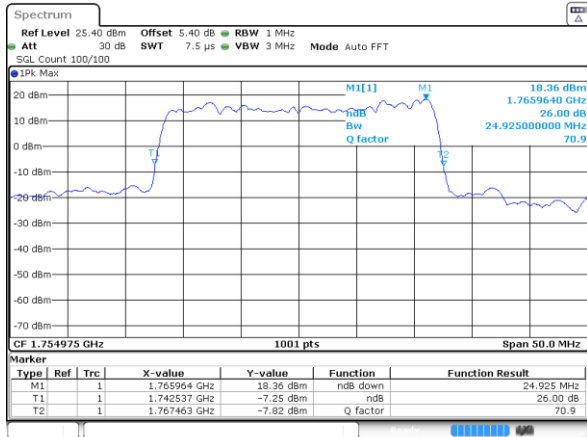

Date: 30 JUN 2020 02:18:25

Middle Channel / 20MHz+10MHz

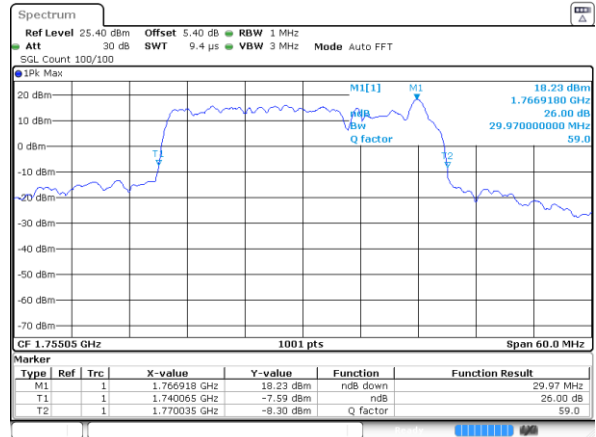

Date: 30 JUN 2020 03:23:31

Highest Channel / 20MHz+5MHz

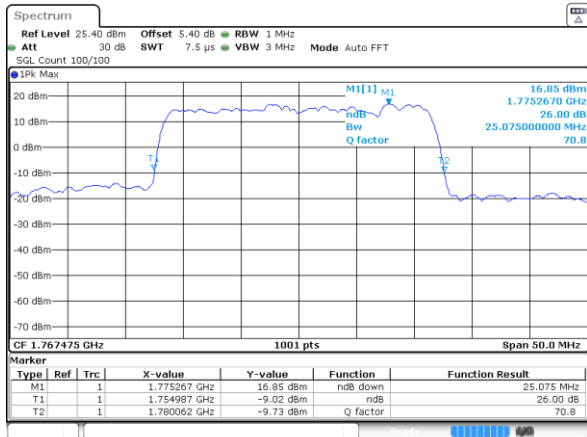

Date: 30 JUN 2020 02:22:36

Highest Channel / 20MHz+10MHz

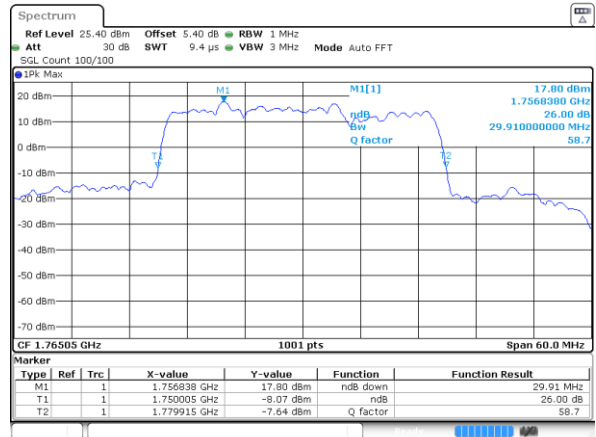

Date: 30 JUN 2020 03:32:55



LTE Band 66C

64QAM

Lowest Channel / 20MHz+15MHz

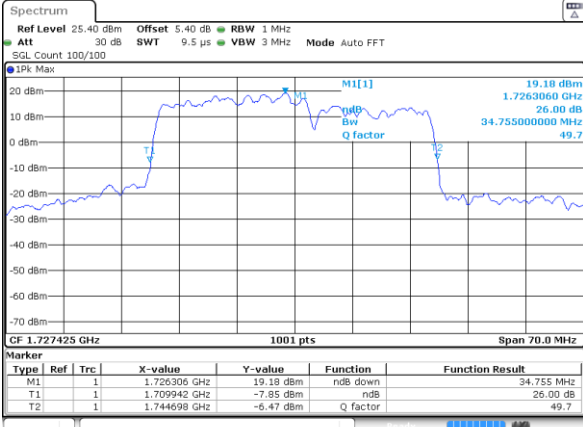

Date: 30 JUN 2020 03:57:10

Lowest Channel / 20MHz+20MHz

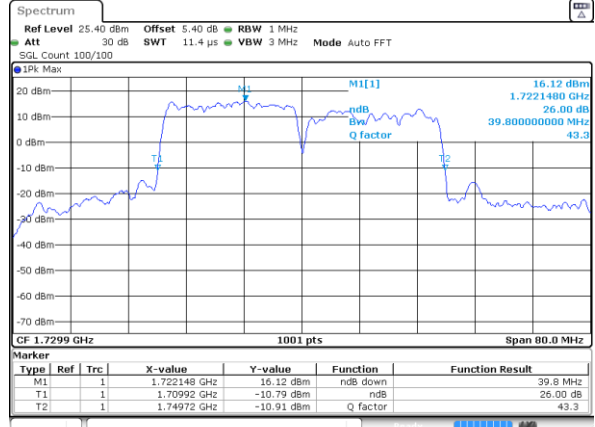

Date: 30 JUN 2020 04:44:30

Middle Channel / 20MHz+15MHz

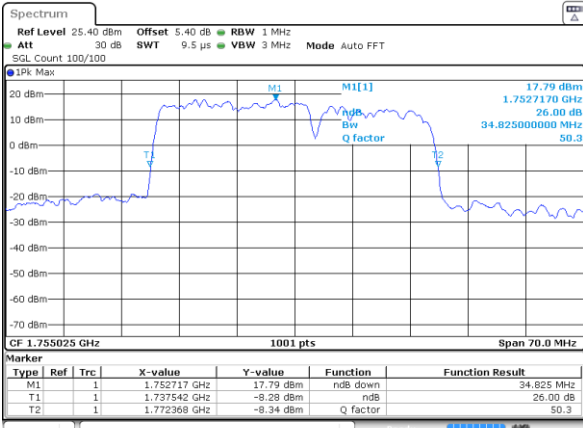

Date: 30 JUN 2020 04:09:28

Middle Channel / 20MHz+20MHz

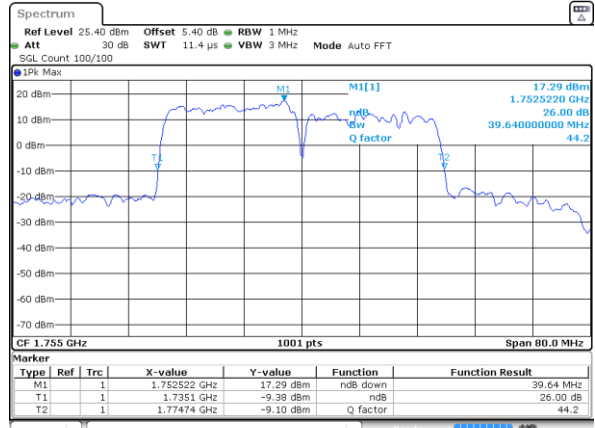

Date: 30 JUN 2020 05:21:25

Highest Channel / 20MHz+15MHz

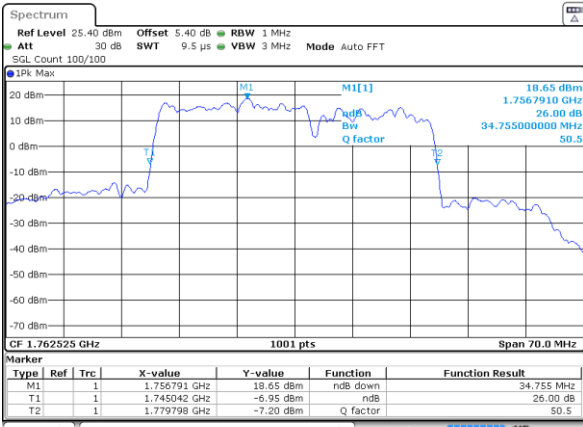

Date: 30 JUN 2020 04:23:41

Highest Channel / 20MHz+20MHz

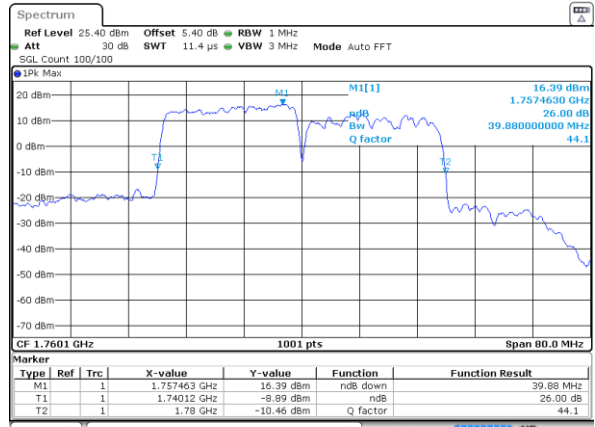

Date: 30 JUN 2020 05:32:04



Occupied Bandwidth

Mode	LTE Band 66C : 99%OBW(MHz)				
QPSK					
BW	5MHz+20MHz	10MHz+15MHz	10MHz+20MHz	15MHz+10MHz	15MHz+15MHz
Lowest CH	23.18	23.48	27.81	23.18	28.23
Middle CH	23.08	23.48	27.87	23.48	28.65
Highest CH	22.98	23.18	27.75	23.33	28.29
BW	15MHz+20MHz	20MHz+5MHz	20MHz+10MHz	20MHz+15MHz	20MHz+20MHz
Lowest CH	32.31	23.33	28.05	32.94	37.88
Middle CH	32.73	23.08	28.05	32.66	37.88
Highest CH	32.94	23.23	28.23	32.45	37.40

Mode	LTE Band 66C : 99%OBW(MHz)				
16QAM					
BW	5MHz+20MHz	10MHz+15MHz	10MHz+20MHz	15MHz+10MHz	15MHz+15MHz
Lowest CH	23.13	23.28	27.99	23.28	28.05
Middle CH	23.28	23.23	28.17	23.23	28.65
Highest CH	23.28	23.28	27.81	23.33	28.41
BW	15MHz+20MHz	20MHz+5MHz	20MHz+10MHz	20MHz+15MHz	20MHz+20MHz
Lowest CH	32.80	23.33	27.99	32.66	37.48
Middle CH	32.87	23.28	27.93	33.01	37.88
Highest CH	32.52	23.28	27.87	32.73	37.24

Mode	LTE Band 66C : 99%OBW(MHz)				
64QAM					
BW	5MHz+20MHz	10MHz+15MHz	10MHz+20MHz	15MHz+10MHz	15MHz+15MHz
Lowest CH	22.93	23.43	27.99	23.28	28.35
Middle CH	22.93	23.48	27.75	23.08	28.35
Highest CH	22.63	23.13	27.81	22.88	28.59
BW	15MHz+20MHz	20MHz+5MHz	20MHz+10MHz	20MHz+15MHz	20MHz+20MHz
Lowest CH	32.66	23.18	27.93	32.59	37.56
Middle CH	32.73	23.08	27.99	32.80	37.40
Highest CH	32.24	23.18	27.93	32.59	37.48



LTE Band 66C

QPSK

Lowest Channel / 5MHz+20MHz

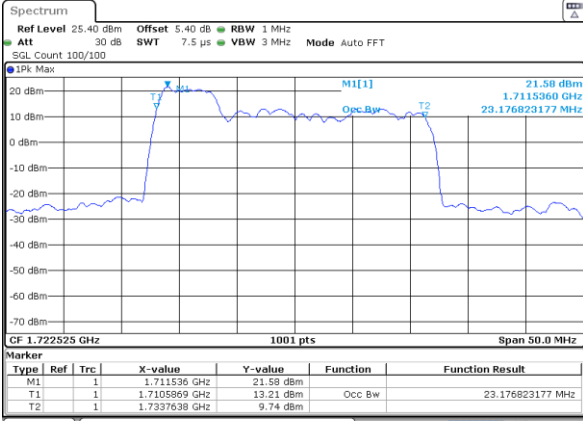

Date: 29 JUN 2020 22:10:25

Lowest Channel / 10MHz+15MHz

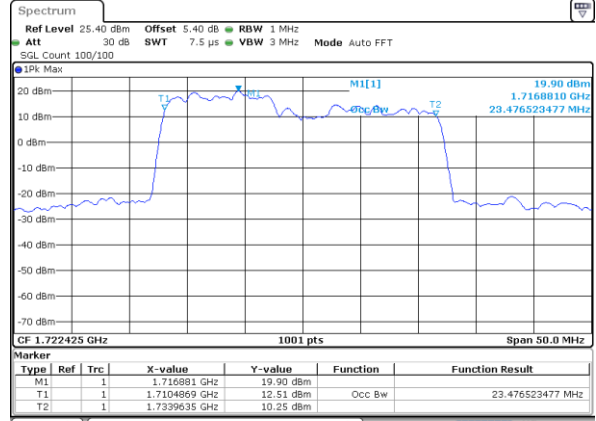

Date: 29 JUN 2020 19:48:26

Middle Channel / 5MHz+20MHz

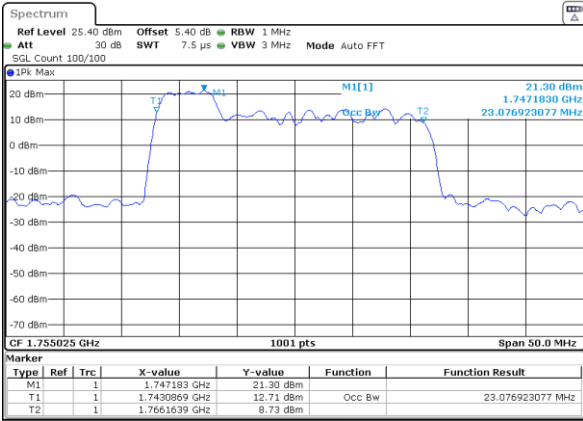

Date: 29 JUN 2020 22:36:17

Middle Channel / 10MHz+15MHz

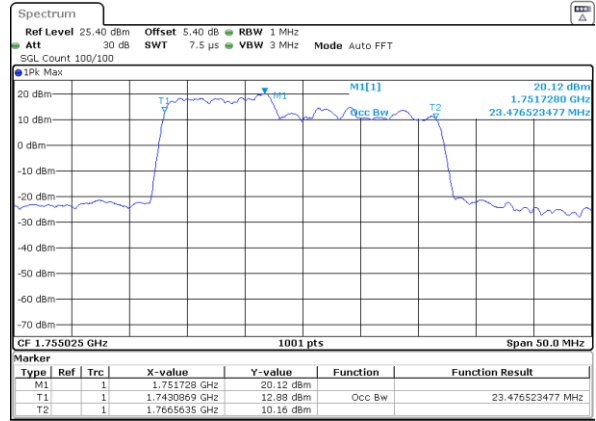

Date: 29 JUN 2020 20:19:47

Highest Channel / 5MHz+20MHz

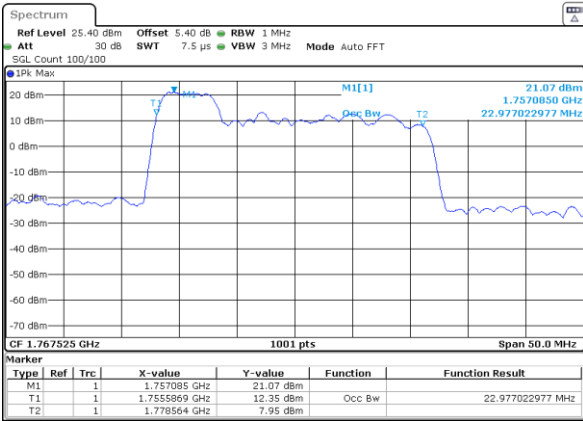

Date: 29 JUN 2020 22:39:45

Highest Channel / 10MHz+15MHz

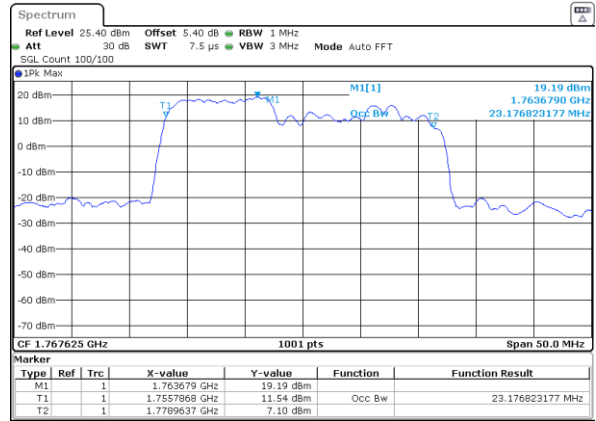

Date: 29 JUN 2020 20:23:33



LTE Band 66C

QPSK

Lowest Channel / 10MHz+20MHz

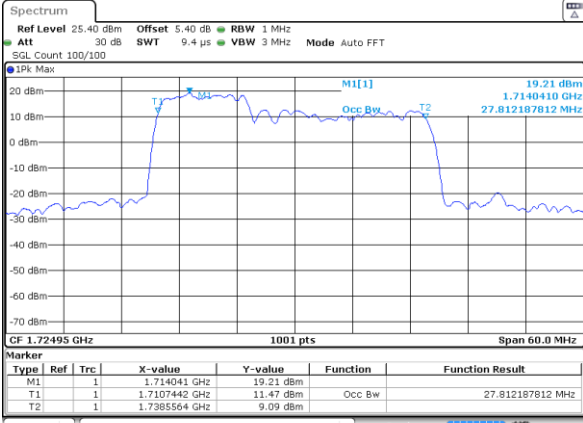

Date: 29 JUN 2020 23 06 07

Lowest Channel / 15MHz+10MHz

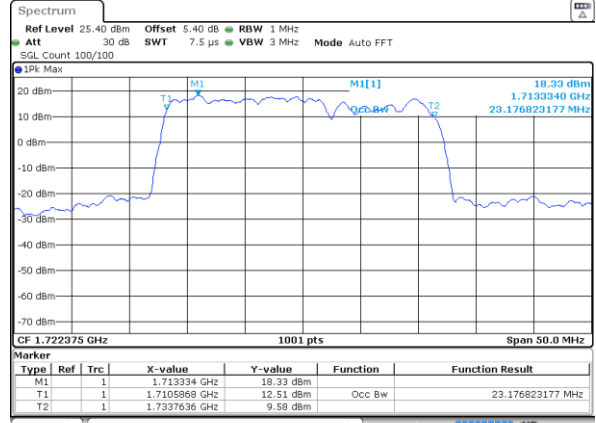

Date: 29 JUN 2020 20 30 47

Middle Channel / 10MHz+20MHz

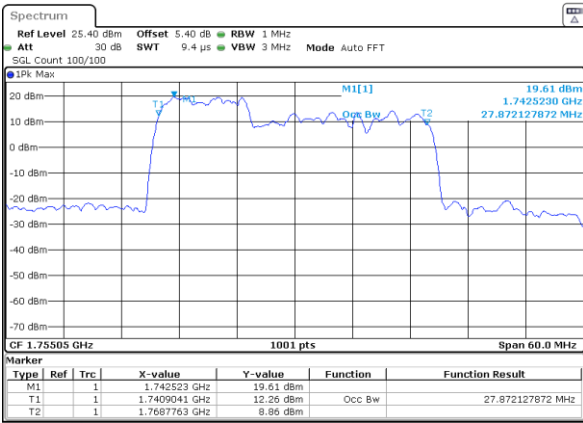

Date: 29 JUN 2020 23 22 39

Middle Channel / 15MHz+10MHz

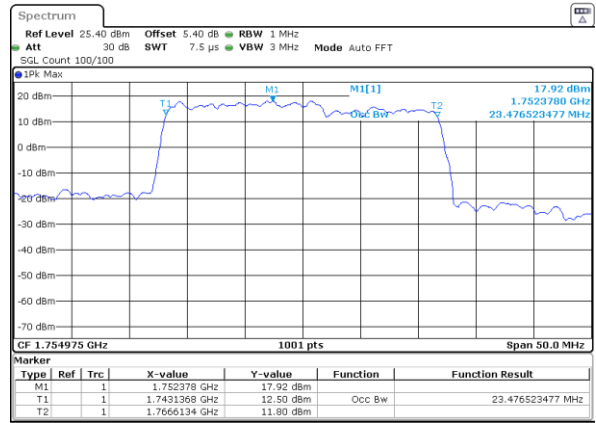

Date: 29 JUN 2020 20 42 01

Highest Channel / 10MHz+20MHz

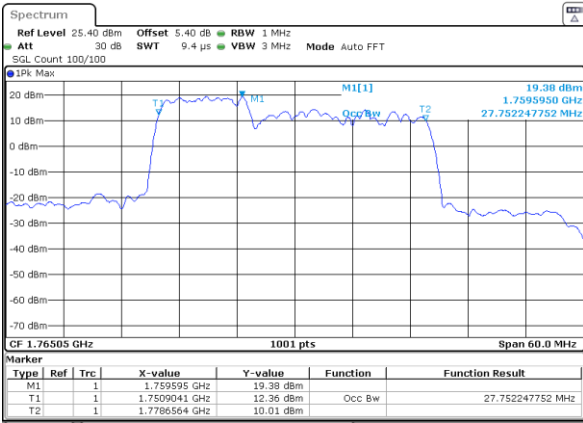

Date: 29 JUN 2020 23 29 52

Highest Channel / 15MHz+10MHz

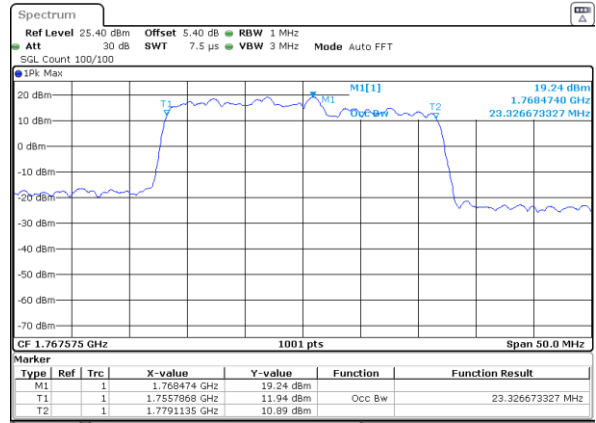

Date: 29 JUN 2020 20 47 25



LTE Band 66C

QPSK

Lowest Channel / 15MHz+15MHz

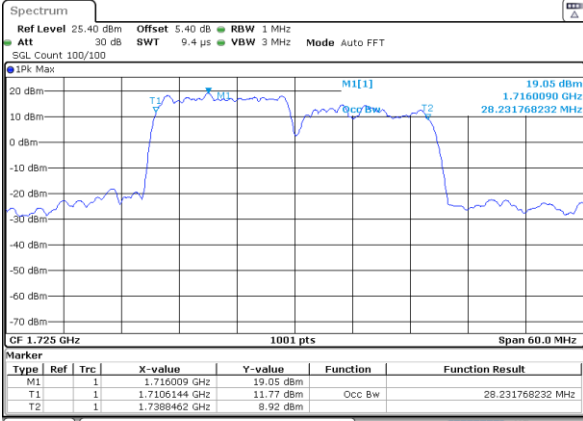

Date: 30 JUN 2020 00:07:04

Lowest Channel / 15MHz+20MHz

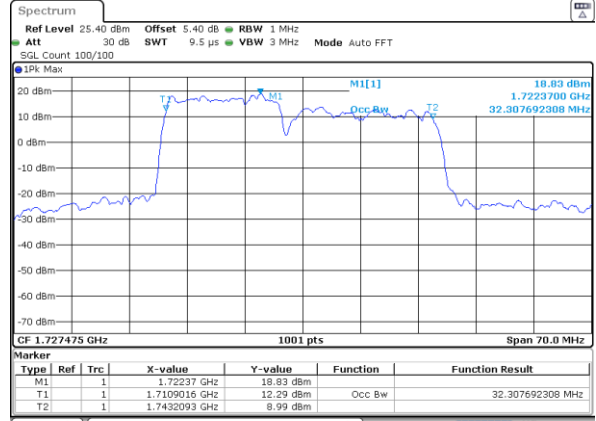

Date: 30 JUN 2020 00:39:56

Middle Channel / 15MHz+15MHz

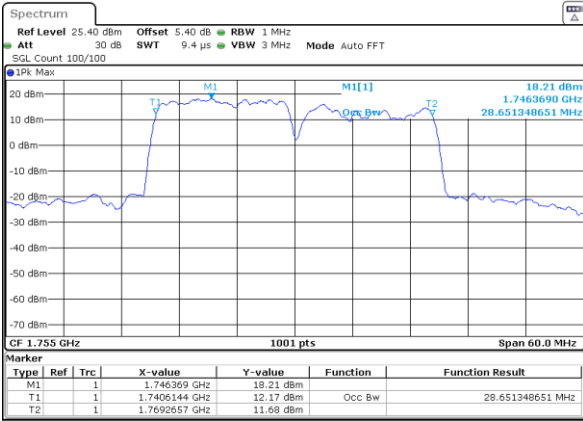

Date: 30 JUN 2020 00:21:57

Middle Channel / 15MHz+20MHz

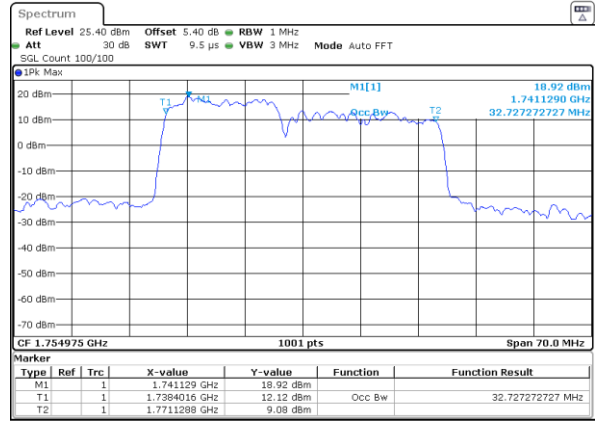

Date: 30 JUN 2020 00:54:10

Highest Channel / 15MHz+15MHz

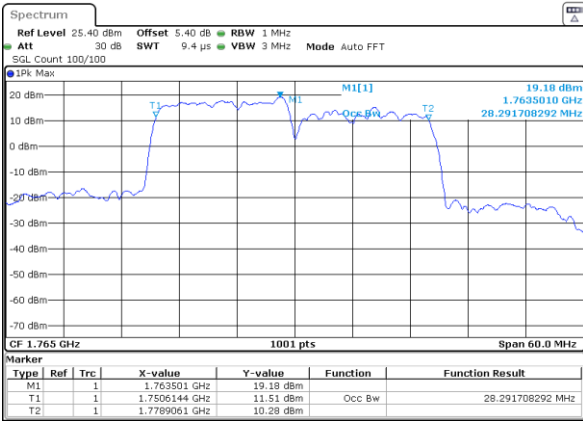

Date: 30 JUN 2020 00:36:31

Highest Channel / 15MHz+20MHz

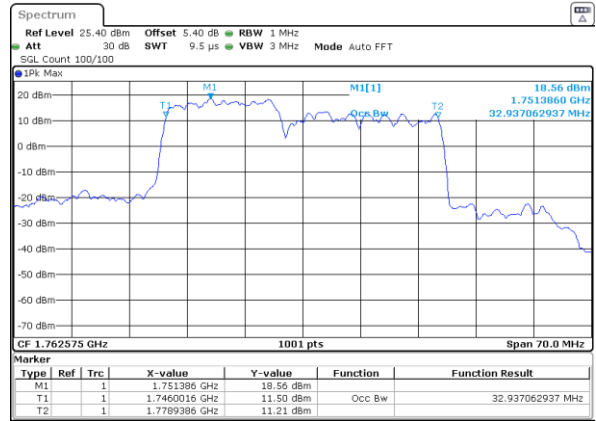

Date: 30 JUN 2020 00:55:14



LTE Band 66C

QPSK

Lowest Channel / 20MHz+5MHz

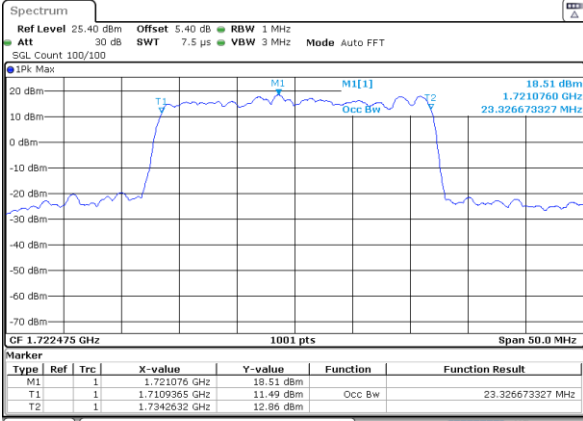

Date: 30 JUN 2020 02:02:45

Lowest Channel / 20MHz+10MHz

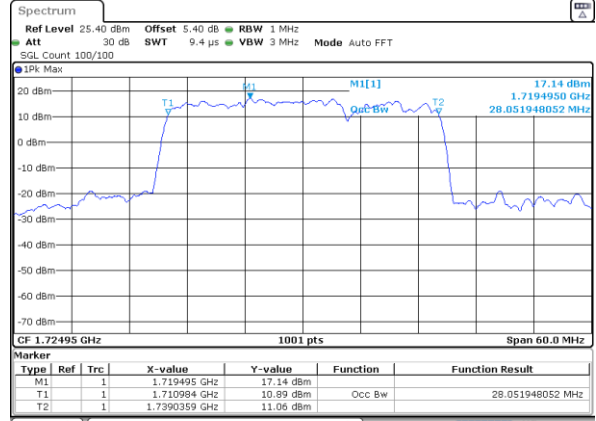

Date: 30 JUN 2020 03:06:29

Middle Channel / 20MHz+5MHz

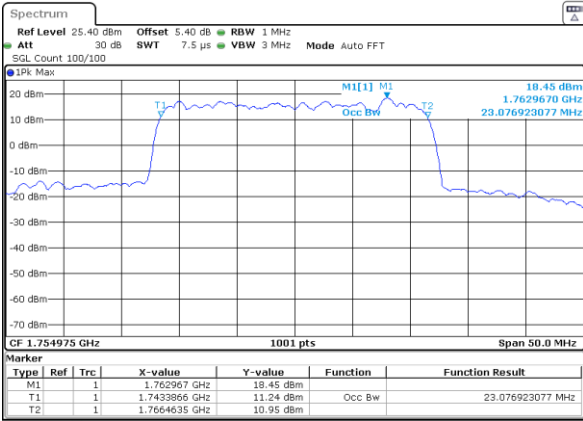

Date: 30 JUN 2020 02:18:48

Middle Channel / 20MHz+10MHz

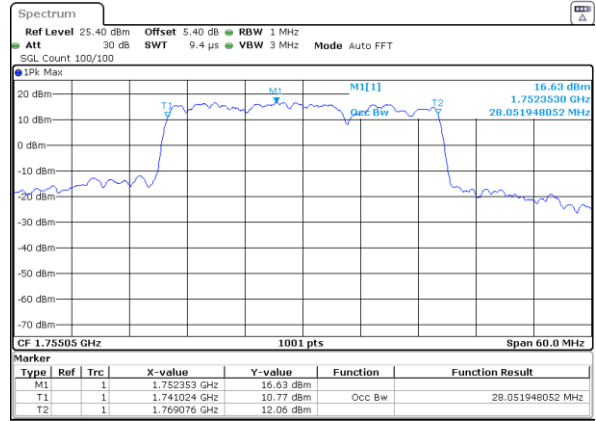

Date: 30 JUN 2020 03:23:51

Highest Channel / 20MHz+5MHz

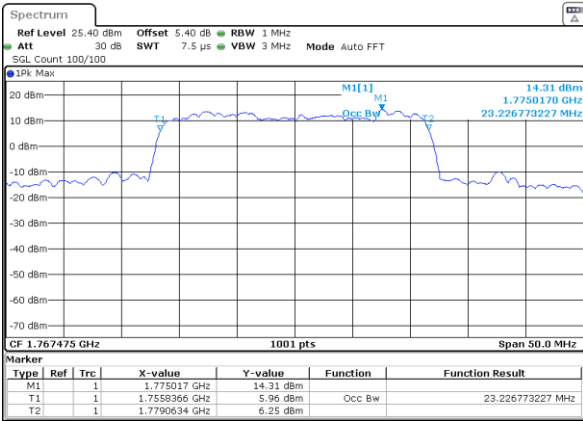

Date: 30 JUN 2020 04:36:56

Highest Channel / 20MHz+10MHz

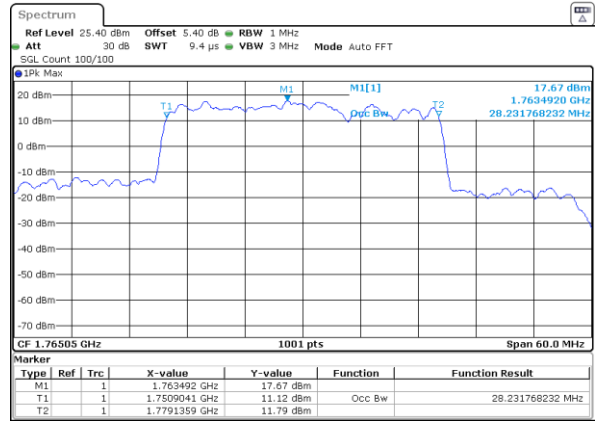

Date: 30 JUN 2020 03:33:51



LTE Band 66C

QPSK

Lowest Channel / 20MHz+15MHz

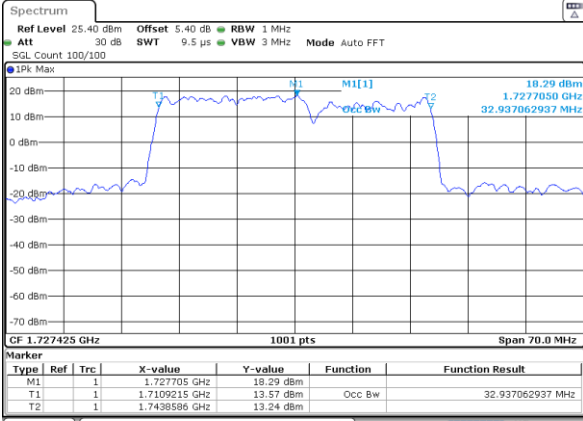

Date: 30 JUN 2020 03:55:21

Lowest Channel / 20MHz+20MHz

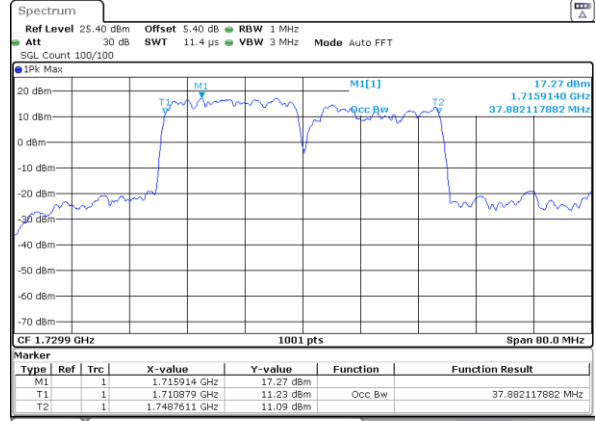

Date: 30 JUN 2020 04:42:43

Middle Channel / 20MHz+15MHz

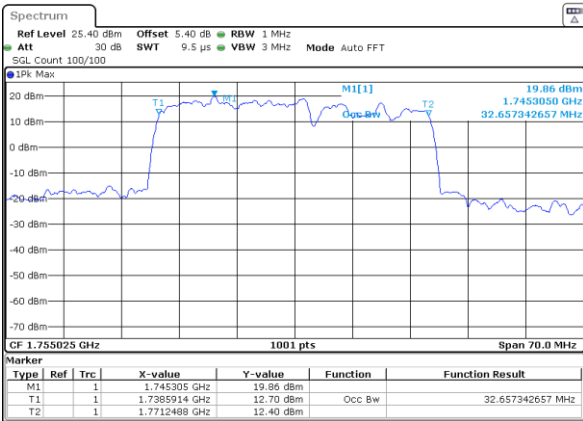

Date: 30 JUN 2020 04:10:09

Middle Channel / 20MHz+20MHz

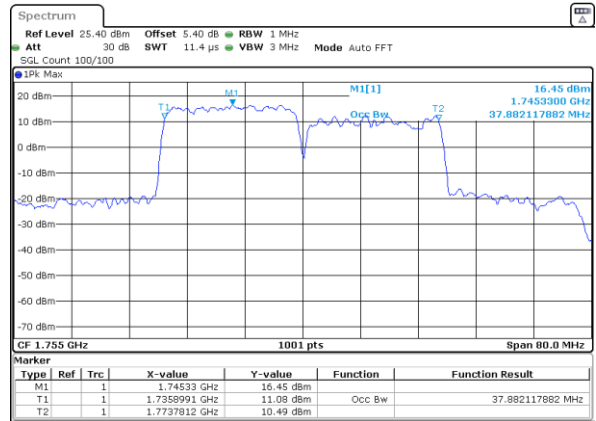

Date: 30 JUN 2020 05:21:44

Highest Channel / 20MHz+15MHz

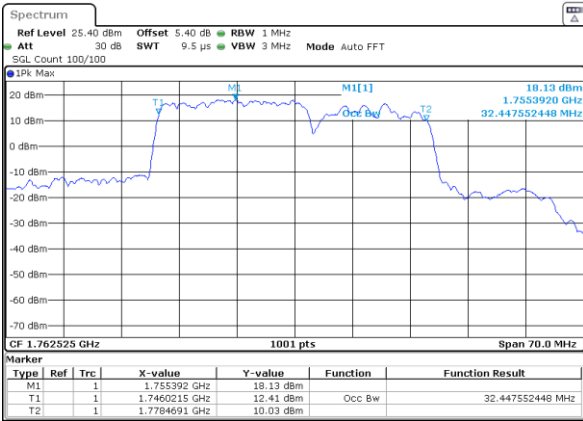

Date: 30 JUN 2020 04:27:57

Highest Channel / 20MHz+20MHz

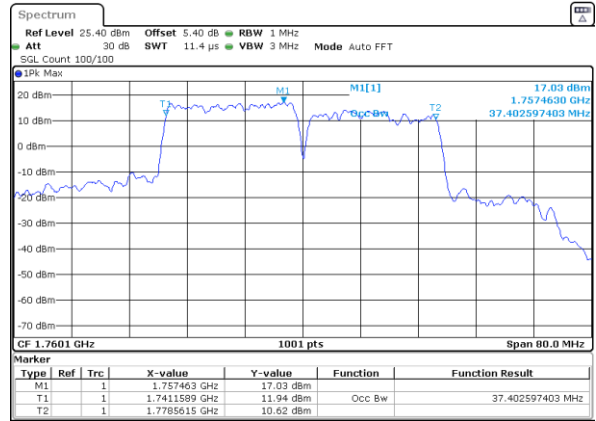

Date: 30 JUN 2020 05:30:45



LTE Band 66C

16QAM

Lowest Channel / 5MHz+20MHz

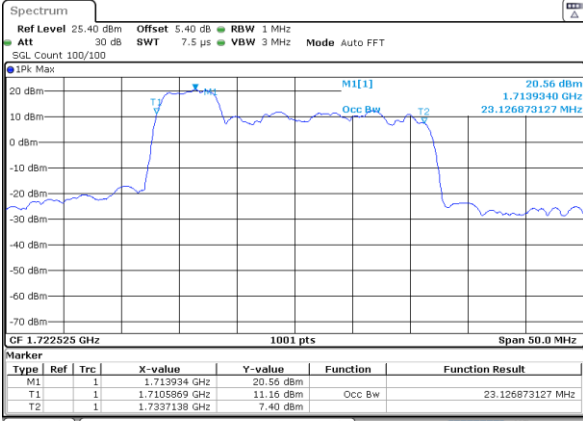

Date: 29 JUN 2020 22:12:06

Lowest Channel / 10MHz+15MHz

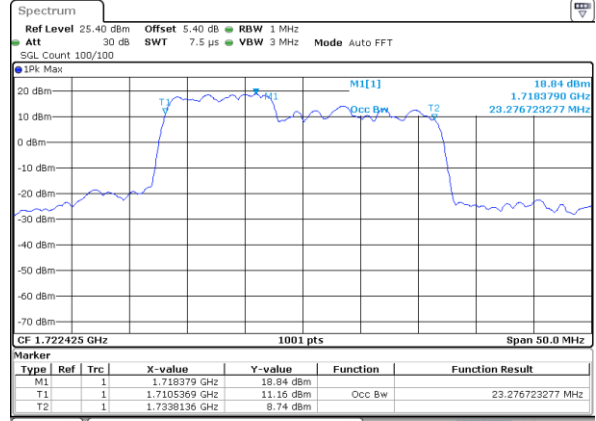

Date: 29 JUN 2020 19:50:27

Middle Channel / 5MHz+20MHz

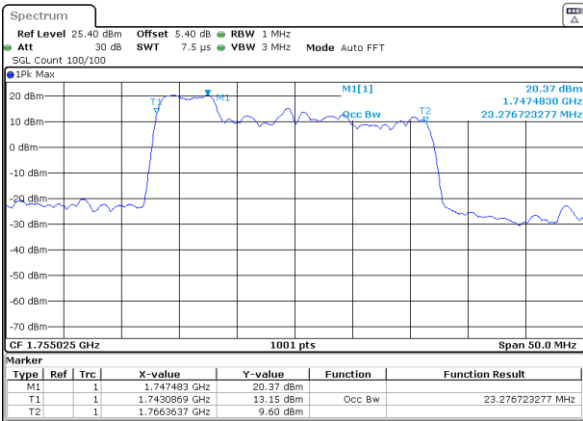

Date: 29 JUN 2020 22:36:40

Middle Channel / 10MHz+15MHz

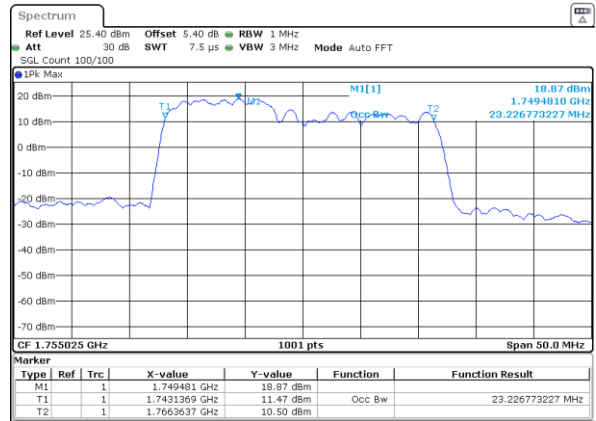

Date: 29 JUN 2020 20:20:09

Highest Channel / 5MHz+20MHz

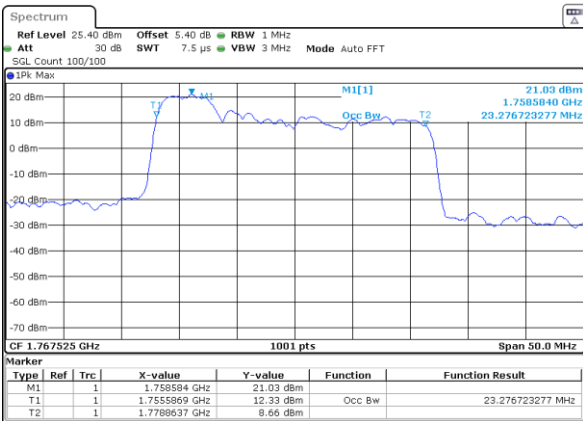

Date: 29 JUN 2020 22:40:47

Highest Channel / 10MHz+15MHz

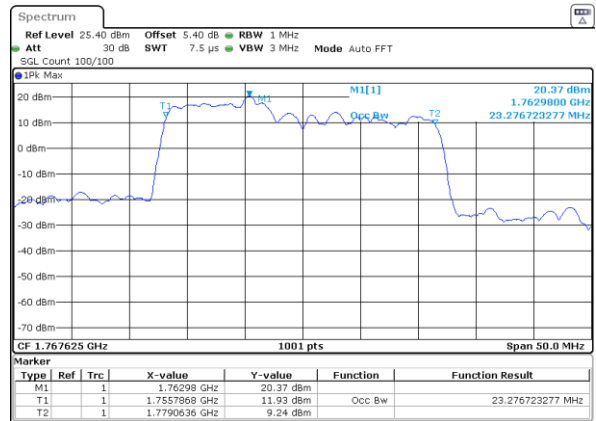

Date: 29 JUN 2020 20:22:41