



# FCC RADIO TEST REPORT

**FCC ID** : IHDT56ZB2  
**Equipment** : Mobile Cellular Phone  
**Brand Name** : Motorola  
**Model Name** : XT2071-4  
**Applicant** : Motorola Mobility, LLC  
222 W Merchandise Mart Plaza, Suite  
1800, Chicago, IL 60654, United States  
**Manufacturer** : Motorola Mobility, LLC  
222 W Merchandise Mart Plaza, Suite  
1800, Chicago, IL 60654, United States  
**Standard** : FCC Part 15 Subpart E §15.407

The product was received on May 07, 2020 and testing was started from May 07, 2020 and completed on Jul. 08, 2020. We, SPORTON INTERNATIONAL INC., EMC & Wireless Communications Laboratory, would like to declare that the tested sample has been evaluated in accordance with the test procedures and has been in compliance with the applicable technical standards.

The test results in this report apply exclusively to the tested model / sample. Without written approval of SPORTON INTERNATIONAL INC. EMC & Wireless Communications Laboratory, the test report shall not be reproduced except in full.

*Louis Wu*

Approved by: Louis Wu

**SPORTON INTERNATIONAL INC. EMC & Wireless Communications Laboratory**  
No. 52, Huaya 1st Rd., Guishan Dist., Taoyuan City, Taiwan (R.O.C.)



## Table of Contents

History of this test report.....	3
Summary of Test Result.....	4
<b>1 General Description .....</b>	<b>5</b>
1.1 Product Feature of Equipment Under Test.....	5
1.2 Product Specification of Equipment Under Test.....	7
1.3 Modification of EUT .....	7
1.4 Testing Location .....	8
1.5 Applicable Standards.....	8
<b>2 Test Configuration of Equipment Under Test .....</b>	<b>9</b>
2.1 Carrier Frequency and Channel .....	9
2.2 Test Mode.....	10
2.3 Connection Diagram of Test System.....	11
2.4 Support Unit used in test configuration and system .....	12
2.5 EUT Operation Test Setup .....	13
2.6 Measurement Results Explanation Example.....	13
<b>3 Test Result .....</b>	<b>14</b>
3.1 6dB and 26dB and 99% Occupied Bandwidth Measurement .....	14
3.2 Maximum Conducted Output Power Measurement .....	18
3.3 Power Spectral Density Measurement .....	19
3.4 Unwanted Emissions Measurement.....	23
3.5 AC Conducted Emission Measurement.....	29
3.6 Automatically Discontinue Transmission .....	31
3.7 Antenna Requirements.....	33
<b>4 List of Measuring Equipment.....</b>	<b>35</b>
<b>5 Uncertainty of Evaluation.....</b>	<b>37</b>
<b>Appendix A. Conducted Test Results</b>	
<b>Appendix B. AC Conducted Emission Test Result</b>	
<b>Appendix C. Radiated Spurious Emission</b>	
<b>Appendix D. Radiated Spurious Emission Plots</b>	
<b>Appendix E. Duty Cycle Plots</b>	





### Summary of Test Result

Report Clause	Ref Std. Clause	Test Items	Result (PASS/FAIL)	Remark
3.1	15.403 (i)	6dB & 26dB Bandwidth	Pass	-
3.1	2.1049	99% Occupied Bandwidth	Reporting only	-
3.2	15.407 (a)	Maximum Conducted Output Power	Pass	-
3.3	15.407 (a)	Power Spectral Density	Pass	-
3.4	15.407(b)	Unwanted Emissions	Pass	Under limit 6.36 dB at 38.730 MHz
3.5	15.207	AC Conducted Emission	Pass	Under limit 17.61 dB at 0.542 MHz
3.6	15.407 (c)	Automatically Discontinue Transmission	Pass	-
3.7	15.203 & 15.407 (a)	Antenna Requirement	Pass	-

**Declaration of Conformity:**

The test results with all measurement uncertainty excluded are presented in accordance with the regulation limits or requirements declared by manufacturers.

**Comments and Explanations:**

The declared of product specification for EUT presented in the report are provided by the manufacturer, and the manufacturer takes all the responsibilities for the accuracy of product specification.

**Reviewed by: Wii Chang**

**Report Producer: Tina Chuang**



# 1 General Description

## 1.1 Product Feature of Equipment Under Test

Product Feature	
Equipment	Mobile Cellular Phone
Brand Name	Motorola
Model Name	XT2071-4
FCC ID	IHDT56ZB2
IMEI Code	<b>Conducted :</b> IMEI 1: 351648110011179 IMEI 2: 351648110011187 <b>Conduction :</b> IMEI 1: 351648110009132 IMEI 2: 351648110009140 <b>Radiation :</b> IMEI 1: 351648110009058 IMEI 2: 351648110009066
EUT supports Radios application	CDMA/EV-DO/GSM/EGPRS/WCDMA/HSPA/LTE/5GNR/ GNSS/NFC WLAN 11a/b/g/n HT20/HT40 WLAN 11ac VHT20/VHT40/VHT80 Bluetooth BR/EDR/LE
HW Version	DVT2
EUT Stage	Identical Prototype

**Remark:** The above EUT's information was declared by manufacturer.



<b>Accessory List</b>	
<b>AC Adapter 1 (US)</b>	Brand Name : Motorola
	Model Name : SC-51
	Manufacturer : Chenyang
<b>AC Adapter 1 (EU)</b>	Brand Name : Motorola
	Model Name : SC-52
	Manufacturer : Chenyang
<b>AC Adapter 1 (UK)</b>	Brand Name : Motorola
	Model Name : SC-53UK
	Manufacturer : Chenyang
<b>AC Adapter 1 (AR)</b>	Brand Name : Motorola
	Model Name : SC-56
	Manufacturer : Chenyang
<b>AC Adapter 1 (AU)</b>	Brand Name : Motorola
	Model Name : SC-55AU
	Manufacturer : Chenyang
<b>AC Adapter 2 (US)</b>	Brand Name : Motorola
	Model Name : SC-51
	Manufacturer : Acbel
<b>AC Adapter 2 (EU)</b>	Brand Name : Motorola
	Model Name : SC-52
	Manufacturer : Acbel
<b>AC Adapter 2 (AR)</b>	Brand Name : Motorola
	Model Name : SC-56
	Manufacturer : Acbel
<b>AC Adapter 3 (IN)</b>	Brand Name : Motorola
	Model Name : SC-54
	Manufacturer : Salom
<b>Battery 1</b>	Brand Name : Motorola
	Model Name : LS30
	Manufacturer : ATL
<b>Battery 2</b>	Brand Name : Motorola
	Model Name : LS40
	Manufacturer : ATL
<b>Standard 3.5mm Headset 1</b>	Brand Name : Motorola
	Model Name : SH38C37773
	Manufacturer : Lianyun
<b>Standard 3.5mm Headset 2</b>	Brand Name : Motorola
	Model Name : SH38C44959
	Manufacturer : Lianyun
<b>USB-C to 3.5mm headset adaptor 1</b>	Brand Name : Motorola
	Model Name : SC18C27844
<b>USB-C to 3.5mm headset adaptor 2</b>	Brand Name : Motorola
	Model Name : SC18C27845
<b>USB Cable 1</b>	Brand Name : Motorola
	Model Name : SC18C24367
	Manufacturer : Saibao
<b>USB Cable 2</b>	Brand Name : Motorola
	Model Name : SC18C24368
	Manufacturer : Luxshare

## 1.2 Product Specification of Equipment Under Test

Standards-related Product Specification										
Tx/Rx Frequency Range	5745 MHz ~ 5825 MHz									
Maximum Output Power to Antenna <CDD Modes>	<b>&lt;5745 MHz ~ 5825 MHz&gt;</b> <b>MIMO &lt;Ant. 4 + 3&gt;</b> 802.11a : 23.38 dBm / 0.2178 W 802.11n HT20 : 22.95 dBm / 0.1972 W 802.11n HT40 : 22.63 dBm / 0.1832 W 802.11ac VHT20: 22.90 dBm / 0.1950 W 802.11ac VHT40: 22.24 dBm / 0.1675 W 802.11ac VHT80: 21.94 dBm / 0.1563 W									
Maximum Output Power to Antenna <TXBF Modes>	<b>&lt;MIMO &lt;Ant. 4 + 3&gt;</b> 802.11ac VHT20: 20.11 dBm / 0.1026 W 802.11ac VHT40: 20.10 dBm / 0.1023 W 802.11ac VHT80: 19.96 dBm / 0.0991 W									
99% Occupied Bandwidth <CDD Modes>	<b>MIMO &lt;Ant. 4&gt;</b> 802.11a : 17.48 MHz 802.11n HT20 : 18.33 MHz 802.11n HT40 : 36.66 MHz 802.11ac VHT80 : 76.84 MHz <b>MIMO &lt;Ant. 3&gt;</b> 802.11a : 25.82 MHz 802.11n HT20 : 22.98 MHz 802.11n HT40 : 37.76 MHz 802.11ac VHT80 : 77.32 MHz									
99% Occupied Bandwidth <TXBF Modes>	<b>MIMO &lt;Ant. 4&gt;</b> 802.11ac VHT20 : 17.88 MHz 802.11ac VHT40 : 37.16 MHz 802.11ac VHT80 : 78.04 MHz <b>MIMO &lt;Ant. 3&gt;</b> 802.11ac VHT20 : 18.08 MHz 802.11ac VHT40 : 37.26 MHz 802.11ac VHT80 : 77.80 MHz									
Type of Modulation	802.11a/n : OFDM (BPSK / QPSK / 16QAM / 64QAM) 802.11ac : OFDM (BPSK / QPSK / 16QAM / 64QAM / 256QAM)									
Antenna Type / Gain	<b>&lt;Ant. 4&gt;</b> : Slot Antenna Type with gain 0.2 dBi <b>&lt;Ant. 3&gt;</b> : IFA Antenna Type with gain 1.0 dBi									
Antenna Function Description	<table border="1"> <thead> <tr> <th></th> <th>Ant. 4</th> <th>Ant. 3</th> </tr> </thead> <tbody> <tr> <td>802.11 a/n/ac MIMO</td> <td>√</td> <td>√</td> </tr> <tr> <td>802.11 ac TXBF</td> <td>√</td> <td>√</td> </tr> </tbody> </table>		Ant. 4	Ant. 3	802.11 a/n/ac MIMO	√	√	802.11 ac TXBF	√	√
	Ant. 4	Ant. 3								
802.11 a/n/ac MIMO	√	√								
802.11 ac TXBF	√	√								

Note: MIMO Ant. 4+3 is a calculated result from sum of the power MIMO Ant. 4 and MIMO Ant. 3

## 1.3 Modification of EUT

No modifications are made to the EUT during all test items.



### 1.4 Testing Location

<b>Test Site</b>	SPORTON INTERNATIONAL INC. EMC & Wireless Communications Laboratory	
<b>Test Site Location</b>	No.52, Huaya 1st Rd., Guishan Dist., Taoyuan City, Taiwan (R.O.C.) TEL: +886-3-327-3456 FAX: +886-3-328-4978	
<b>Test Site No.</b>	<b>Sporton Site No.</b>	
	TH-05-HY	CO05-HY

**Note:** The test site complies with ANSI C63.4 2014 requirement.

<b>Test Site</b>	SPORTON INTERNATIONAL INC. EMC & Wireless Communications Laboratory	
<b>Test Site Location</b>	No.58, Aly. 75, Ln. 564, Wenhua 3rd, Rd., Guishan Dist., Taoyuan City, Taiwan (R.O.C.) TEL: +886-3-327-0868 FAX: +886-3-327-0855	
<b>Test Site No.</b>	<b>Sporton Site No.</b>	
	03CH15-HY	

**Note:** The test site complies with ANSI C63.4 2014 requirement.

FCC designation No.: TW1190 and TW0007

### 1.5 Applicable Standards

According to the specifications of the manufacturer, the EUT must comply with the requirements of the following standards:

- ♦ FCC Part 15 Subpart E
- ♦ FCC KDB 789033 D02 General UNII Test Procedures New Rules v02r01.
- ♦ FCC KDB 414788 D01 Radiated Test Site v01r01.
- ♦ FCC KDB 662911 D01 Multiple Transmitter Output v02r01.
- ♦ ANSI C63.10-2013

**Remark:**

1. All test items were verified and recorded according to the standards and without any deviation during the test.
2. The TAF code is not including all the FCC KDB listed without accreditation.
3. This EUT has also been tested and complied with the requirements of FCC Part 15, Subpart B, recorded in a separate test report.



## 2 Test Configuration of Equipment Under Test

- a. The EUT has been associated with peripherals and configuration operated in a manner tended to maximize its emission characteristics in a typical application. Frequency range investigated: conduction emission (150 kHz to 30 MHz), radiation emission (9 kHz to the 10th harmonic of the highest fundamental frequency or to 40 GHz, whichever is lower). For radiated measurement, pre-scanned in three orthogonal panels, X, Y, Z. The worst cases (Opend Mode: X plane with Adapter for CDD Mode and Close Mode: Z plane with Notebook for TXBF Mode) were recorded in this report.
- b. AC power line Conducted Emission was tested under maximum output power.

### 2.1 Carrier Frequency and Channel

Frequency Band	Channel	Freq. (MHz)	Channel	Freq. (MHz)
5725-5850 MHz Band 4 (U-NII-3)	149	5745	157	5785
	151*	5755	159*	5795
	153	5765	161	5805
	155#	5775	165	5825

**Note:**

1. The above Frequency and Channel in "\*" were 802.11n HT40 and 802.11ac VHT40.
2. The above Frequency and Channel in "#n" were 802.11ac VHT80.



## 2.2 Test Mode

Final test modes are considering the modulation and worse data rates as below table.

### CDD Mode

Modulation	Data Rate
802.11a	6 Mbps
802.11n HT20	MCS0
802.11n HT40	MCS0
802.11ac VHT20 (Covered by HT20)	MCS0
802.11ac VHT40 (Covered by HT40)	MCS0
802.11ac VHT80	MCS0

### TXBF Mode

Modulation	Data Rate
802.11ac VHT20	MCS0
802.11ac VHT40	MCS0
802.11ac VHT80	MCS0

Test Cases	
<b>AC Conducted Emission</b>	Mode 1 : GSM 1900 Idle + WLAN (5GHz) Link + Bluetooth Link + USB Cable 1 (Charging from AC Adapter 1) + SIM 2
<b>Remark:</b> For Radiated Test Cases, the tests were performed with AC Adapter 1 (US) and USB Cable 1.	

Ch. #	Band IV : 5725-5850 MHz		
	802.11ac VHT20	802.11ac VHT40	802.11ac VHT80
L Low	149	151	-
M Middle	157	-	155
H High	165	159	-

**Remark:** For radiation spurious emission, the final modulation and the worst data rate was reference the max RF conducted power.

## 2.3 Connection Diagram of Test System

<CDD Mode>

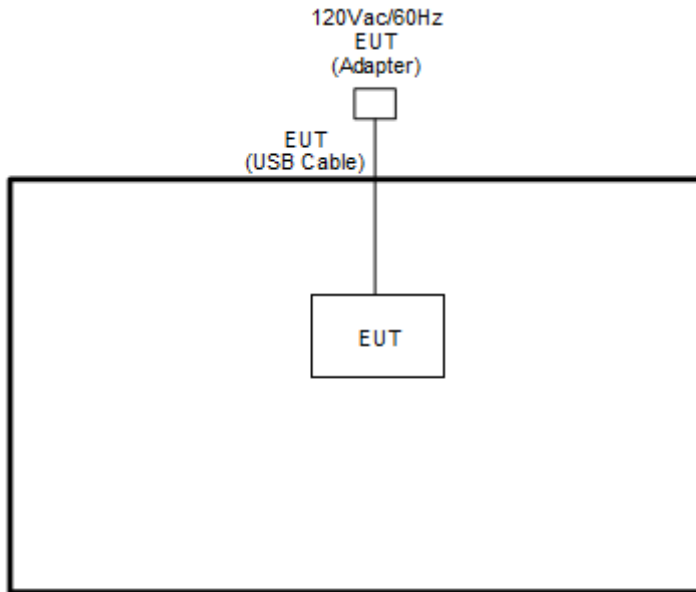

<TXBF Mode>

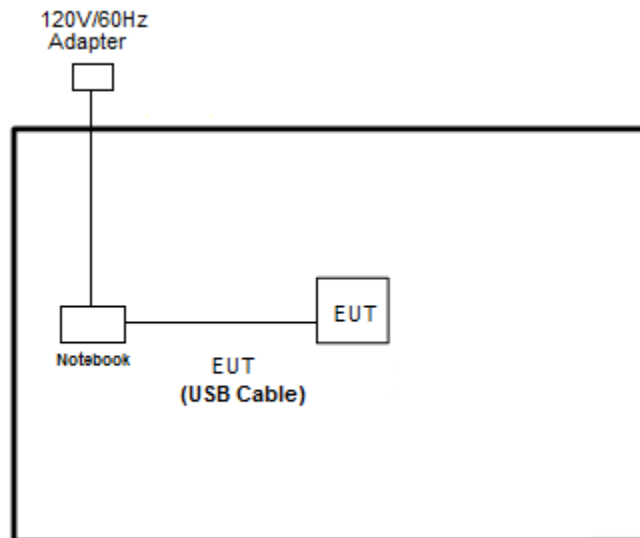

<AC Conducted Emission Mode>

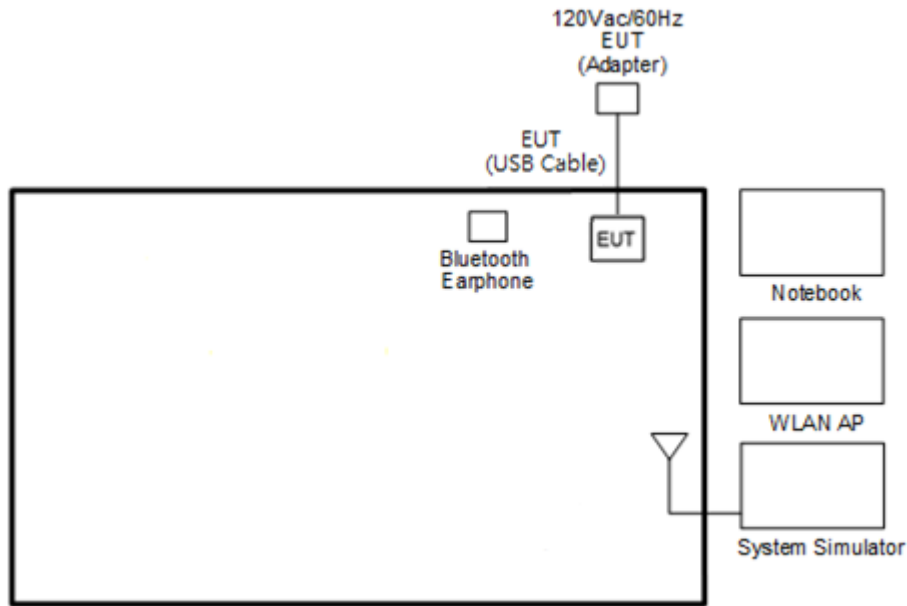

**2.4 Support Unit used in test configuration and system**

Item	Equipment	Trade Name	Model Name	FCC ID	Data Cable	Power Cord
1.	System Simulator	Anritsu	MT8820C	N/A	N/A	Unshielded, 1.8 m
2.	Bluetooth Earphone	Sony Ericsson	MW600	PY7DDA-2029	N/A	N/A
3.	WLAN AP	ASUS	RT-AC66U	MSQ-RTAC66U	N/A	Unshielded, 1.8 m
4.	Notebook	DELL	Latitude 3400	FCC DoC	N/A	AC I/P: Unshielded, 1.2 m DC O/P: Shielded, 1.8 m



## 2.5 EUT Operation Test Setup

The RF test items, utility “QRCT V4.0.00156.0” was installed in Notebook which was programmed in order to make the EUT get into the engineering modes to provide channel selection, power level, data rate and the application type and for continuous transmitting signals.

For TXBF mode, the modulation modes and data rates manipulated by the command lines in the engineering program made the EUT link to another EUT by power under the normal operation. The “cmd” software tool was used to enable the EUT to transmit signals continuously.

## 2.6 Measurement Results Explanation Example

**For all conducted test items:**

The offset level is set in the spectrum analyzer to compensate the RF cable loss and attenuator factor between EUT conducted output port and spectrum analyzer. With the offset compensation, the spectrum analyzer reading level is exactly the EUT RF output level.

Example :

The spectrum analyzer offset is derived from RF cable loss and attenuator factor.

*Offset = RF cable loss + attenuator factor.*

Following shows an offset computation example with cable loss 4.2 dB and 10dB attenuator.

$$\begin{aligned} \text{Offset(dB)} &= \text{RF cable loss(dB)} + \text{attenuator factor(dB)}. \\ &= 4.2 + 10 = 14.2 \text{ (dB)} \end{aligned}$$

### 3 Test Result

#### 3.1 6dB and 26dB and 99% Occupied Bandwidth Measurement

##### 3.1.1 Description of 6dB and 26dB and 99% Occupied Bandwidth

The minimum 6 dB bandwidth shall be at least 500 kHz.

26dB and 99% Occupied bandwidth are reporting only.

##### 3.1.2 Measuring Instruments

See list of measuring equipment of this test report.

##### 3.1.3 Test Procedures

1. The testing follows FCC KDB 789033 D02 General UNII Test Procedures New Rules v02r01. Section C) Emission bandwidth for the band 5.725-5.85GHz
2. Set RBW = 100kHz.
3. Set the VBW  $\geq 3 \times$  RBW.
4. Detector = Peak.
5. Trace mode = max hold
6. Measure the maximum width of the emission that is 6 dB down from the peak of the emission.
7. Measure and record the results in the test report.

##### 3.1.4 Test Setup

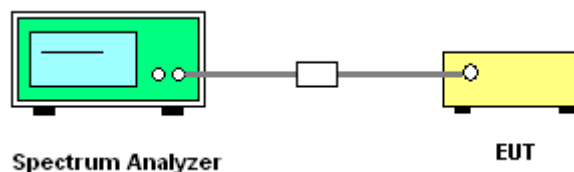

##### 3.1.5 Test Result of 6dB and 26dB and 99% Occupied Bandwidth

Please refer to Appendix A.



<CDD Mode>

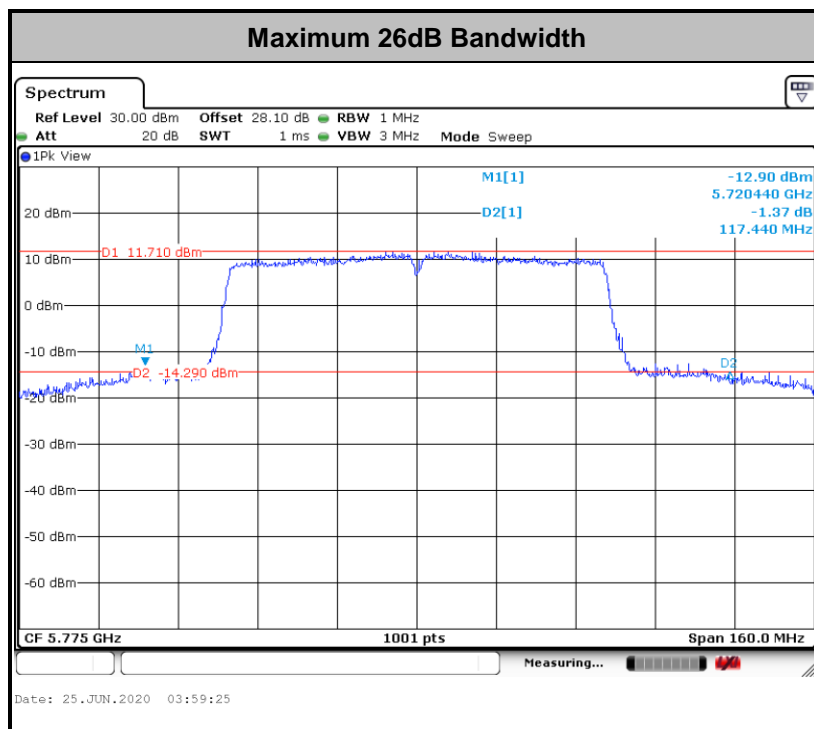
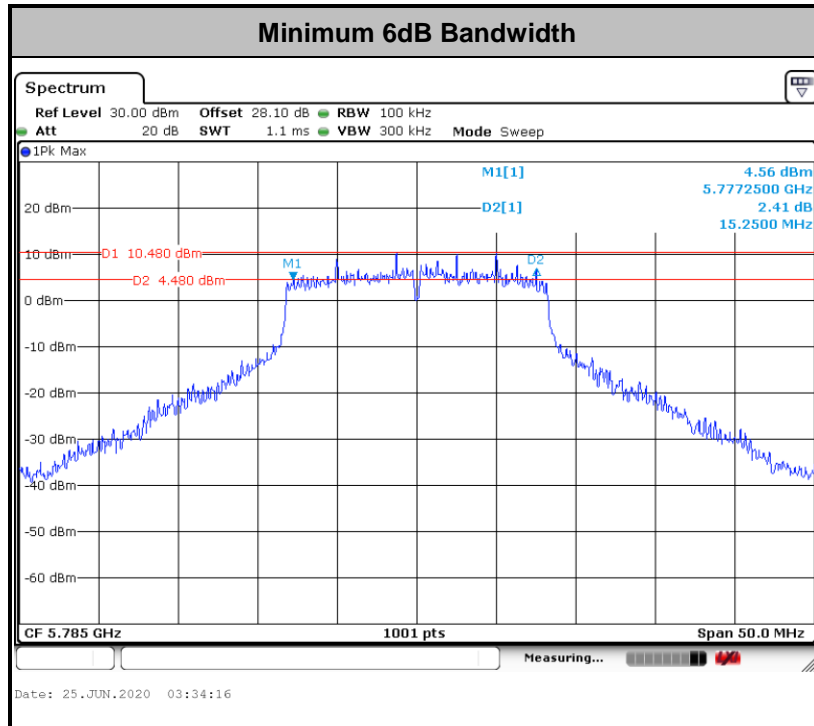

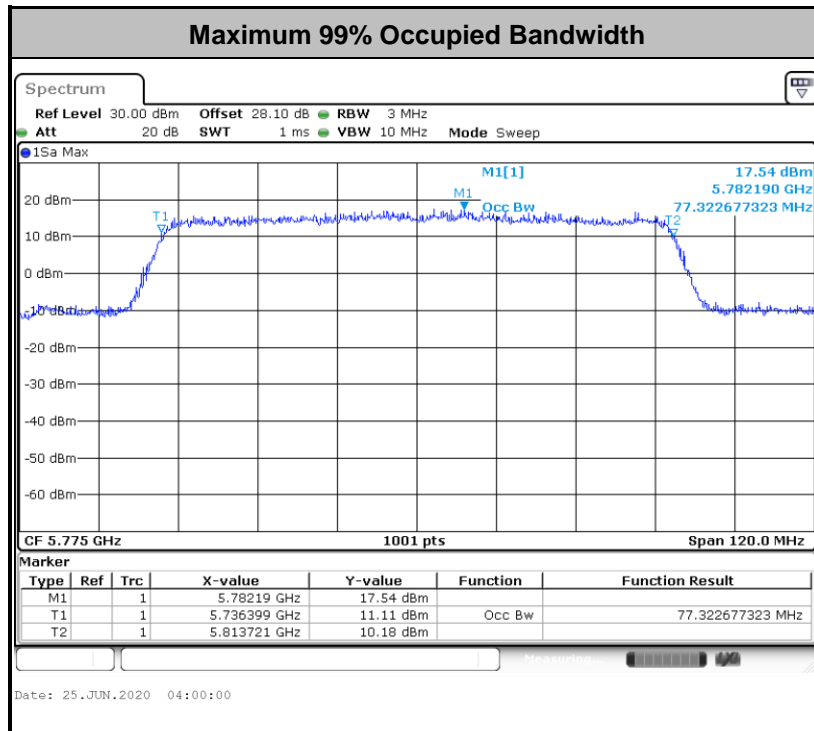

**Note:** The occupied channel bandwidth is maintained within the band of operation for all of the modulations.

<TXBF Modes>

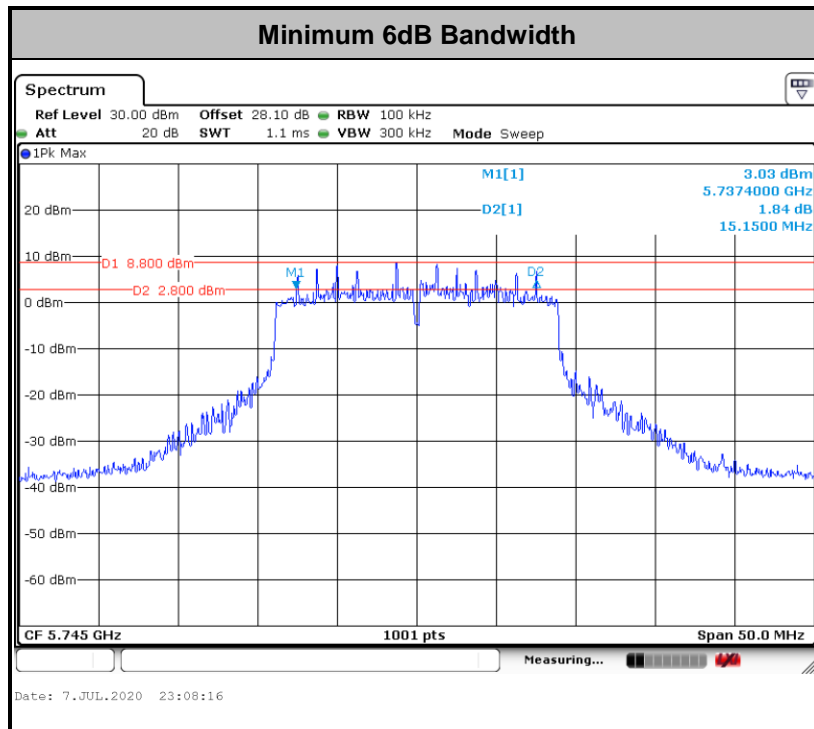

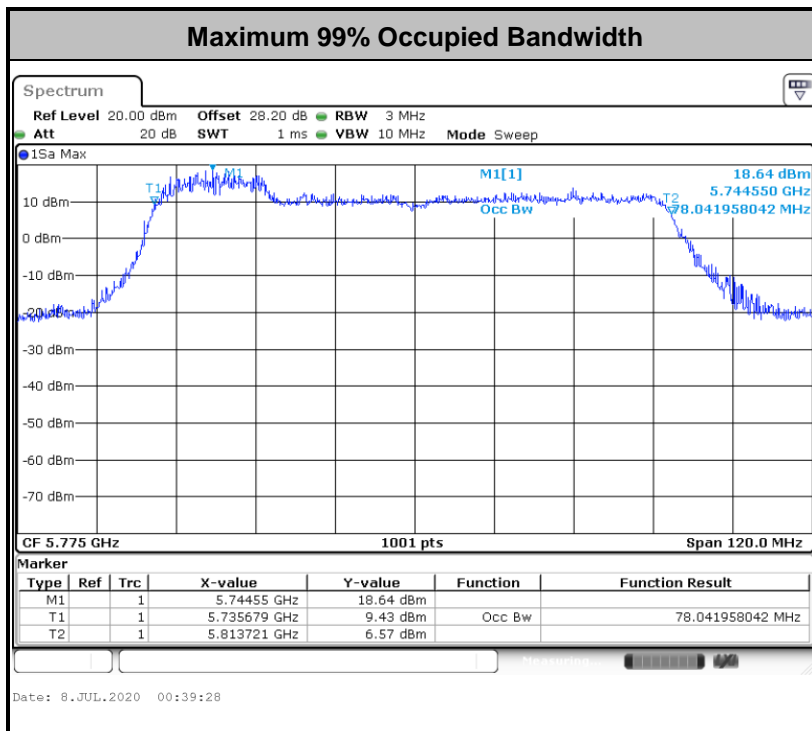
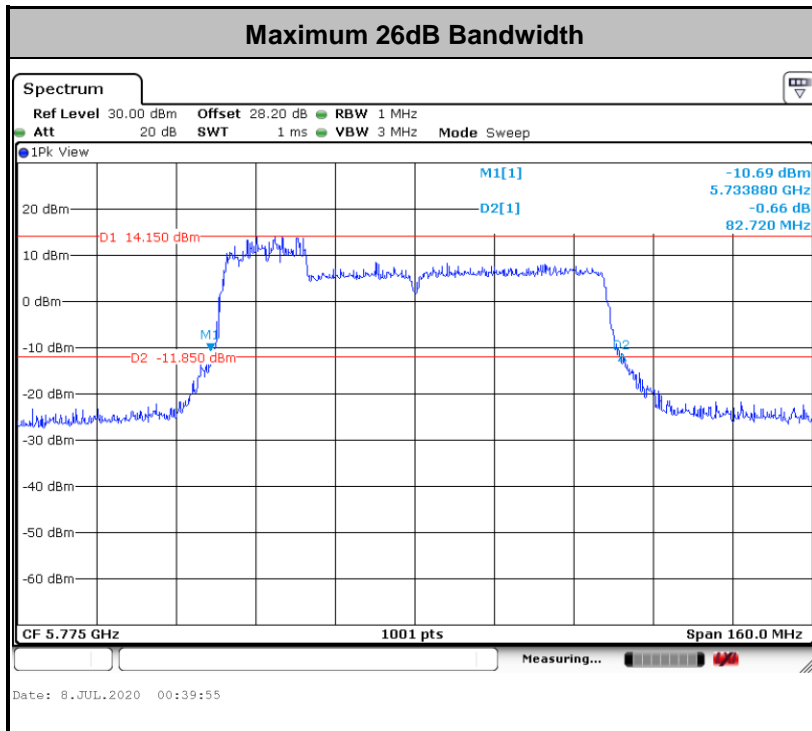

**Note:** The occupied channel bandwidth is maintained within the band of operation for all of the modulations.

## 3.2 Maximum Conducted Output Power Measurement

### 3.2.1 Limit of Maximum Conducted Output Power

For the band 5.725–5.85 GHz, the maximum conducted output power over the frequency band of operation shall not exceed 1 W.

If transmitting antennas of directional gain greater than 6 dBi are used, the peak output power shall be reduced by the amount in dB that the directional gain of the antenna exceeds 6 dBi.

### 3.2.2 Measuring Instruments

See list of measuring equipment of this test report.

### 3.2.3 Test Procedures

The testing follows Method PM-G of FCC KDB 789033 D02 General UNII Test Procedures New Rules v02r01.

Method PM-G (Measurement using a gated RF average power meter):

1. Measurement is performed using a wideband RF power meter.
2. The EUT is configured to transmit at its maximum power control level.
3. Measure the average power of the transmitter
4. Since the measurement is made only during the ON time of the transmitter, no duty cycle correction factor is required.

### 3.2.4 Test Setup

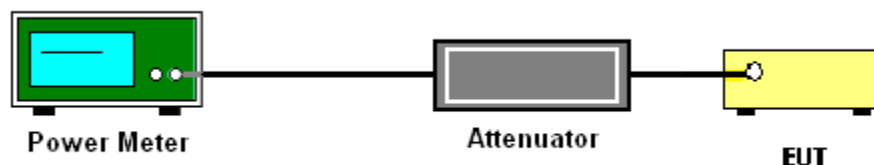

### 3.2.5 Test Result of Maximum Conducted Output Power

Please refer to Appendix A.



### 3.3 Power Spectral Density Measurement

#### 3.3.1 Limit of Power Spectral Density

For the band 5.725–5.85 GHz, the maximum power spectral density shall not exceed 30 dBm in any 500-kHz band.

If transmitting antennas of directional gain greater than 6 dBi are used, the peak output power shall be reduced by the amount in dB that the directional gain of the antenna exceeds 6 dBi.

#### 3.3.2 Measuring Instruments

See list of measuring equipment of this test report.

#### 3.3.3 Test Procedures

The testing follows FCC KDB 789033 D02 General UNII Test Procedures New Rules v02r01. Section F) Maximum power spectral density.

##### # Method SA-3 #

(power averaging (rms) detection with max hold):

- Set span to encompass the entire emission bandwidth (EBW) of the signal.
- Set RBW = 300 kHz.
- Set VBW  $\geq$  1 MHz.
- Number of points in sweep  $\geq$  2 Span / RBW.
- Sweep time  $\leq$  (number of points in sweep)  $\times$  T, when duty cycle is less than 98 percent where T is the minimum transmission duration over which the transmitter is on and is transmitting at its maximum power control level for the tested mode of operation.
- Detector = power averaging (rms).
- Trace mode = max hold.
- Allow max hold to run for at least 60 seconds, or longer as needed to allow the trace to stabilize.

1. The RF output of EUT was connected to the spectrum analyzer by a low loss cable.
2. Each plot has already offset with cable loss, and attenuator loss. Measure the PPSD and record it.
3. For MIMO mode, calculation method follows FCC KDB 662911 D01 Multiple Transmitter Output v02r01.

Method (c): Measure and add  $10 \log(N_{ANT})$  dB.

With this technique, spectrum measurements are performed at each output of the device, but rather than summing the spectra or the spectral peaks across the outputs, the quantity  $10 \log(N_{ANT})$  dB is added to each spectrum value before comparing to the emission limit. The addition of  $10 \log(N_{ANT})$  dB serves to apportion the emission limit among the  $N_{ANT}$  outputs so that each output is permitted to contribute no more than  $1/N_{ANT}^{\text{th}}$  of the PSD limit.

### 3.3.4 Test Setup

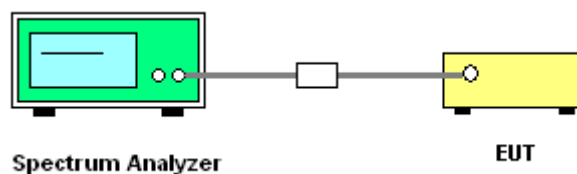



### 3.3.5 Test Result of Power Spectral Density

Please refer to Appendix A.

<CDD Modes>

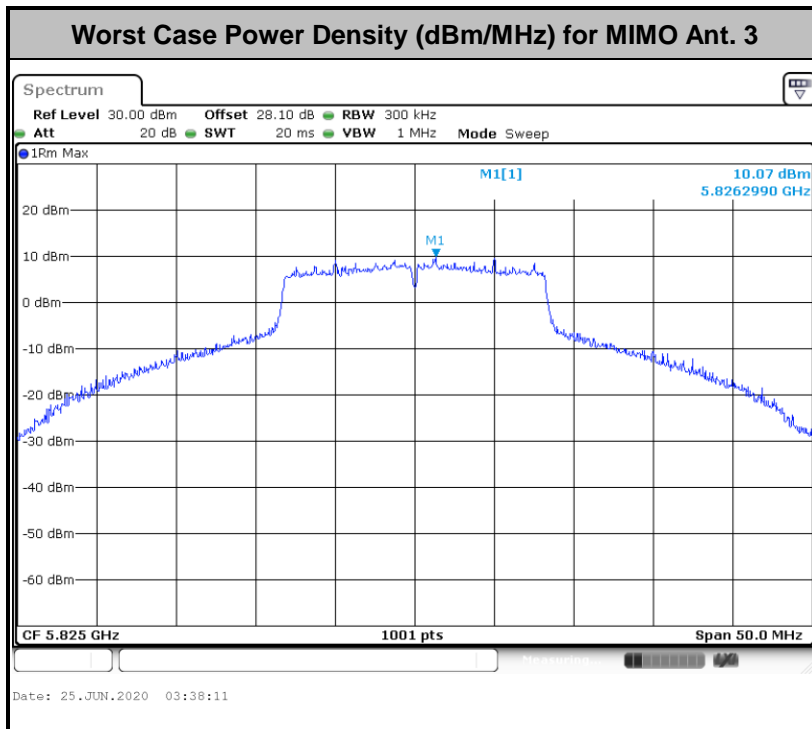
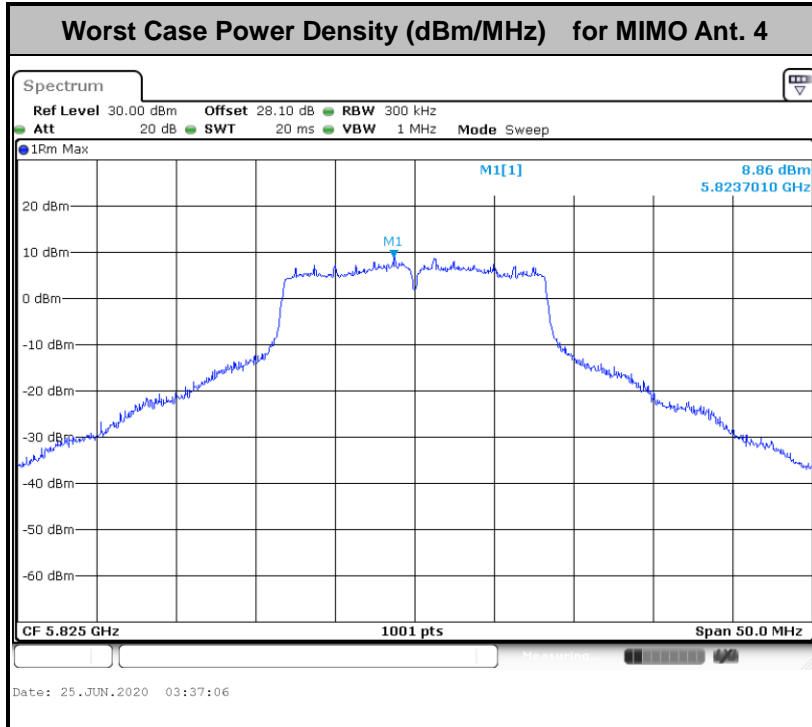



<TXBF Modes>

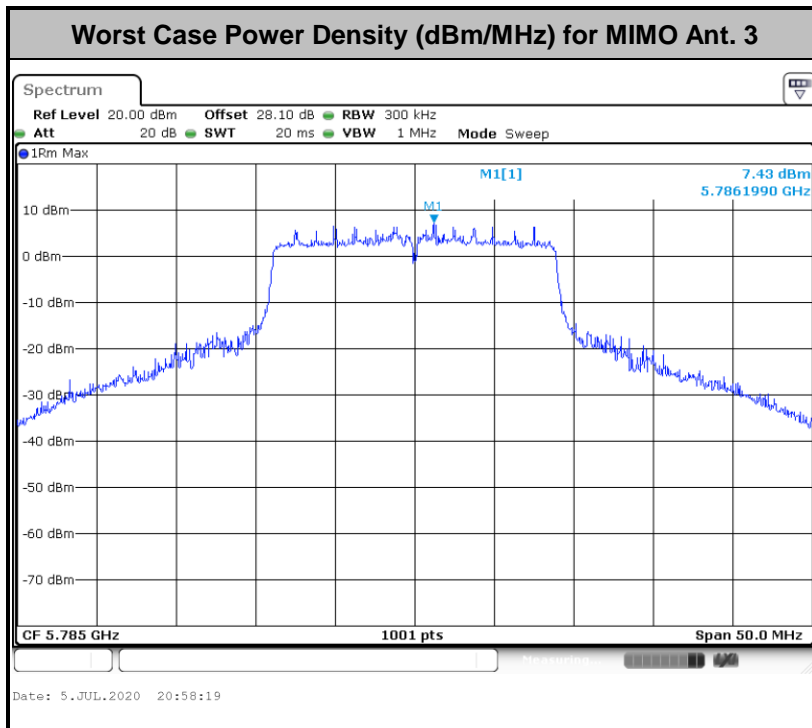
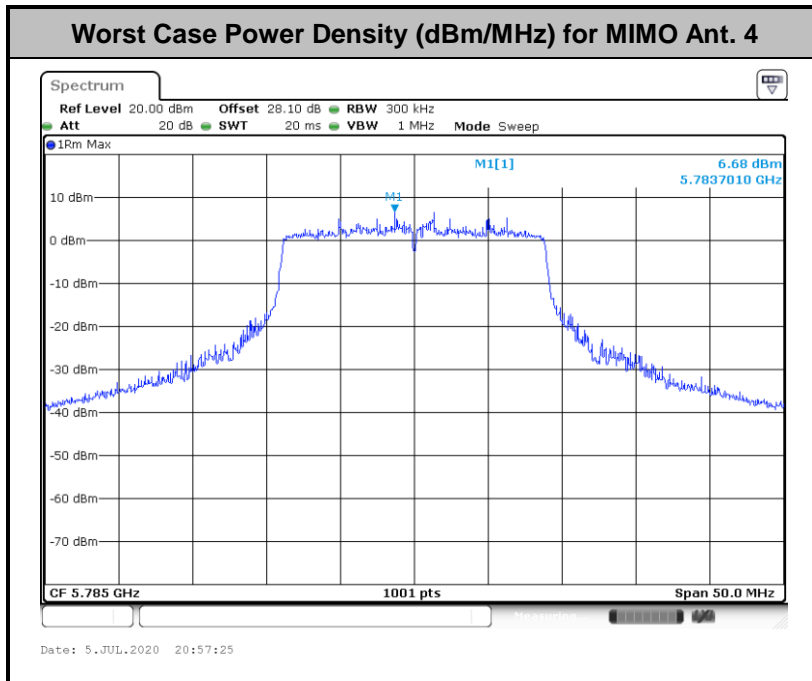



### 3.4 Unwanted Emissions Measurement

This section is to measure unwanted emissions through radiated measurement for band edge spurious emissions and out of band emissions measurement.

#### 3.4.1 Limit of Unwanted Emissions

(1) For transmitters operating in the 5.725-5.85 GHz band:

15.407(b)(4)(i) All emissions shall be limited to a level of -27 dBm/MHz at 75 MHz or more above or below the band edge increasing linearly to 10 dBm/MHz at 25 MHz above or below the band edge, and from 25 MHz above or below the band edge increasing linearly to a level of 15.6 dBm/MHz at 5 MHz above or below the band edge, and from 5 MHz above or below the band edge increasing linearly to a level of 27 dBm/MHz at the band edge.

(2) Unwanted spurious emissions fallen in restricted bands shall comply with the general field strength limits as below table,

Frequency (MHz)	Field Strength (microvolts/meter)	Measurement Distance (meters)
0.009 – 0.490	2400/F(kHz)	300
0.490 – 1.705	24000/F(kHz)	30
1.705 – 30.0	30	30
30 – 88	100	3
88 – 216	150	3
216 - 960	200	3
Above 960	500	3

**Note:** The following formula is used to convert the EIRP to field strength.

$$E = \frac{1000000\sqrt{30P}}{3} \text{ } \mu\text{V/m, where P is the eirp (Watts)}$$



EIRP (dBm)	Field Strength at 3m (dBμV/m)
- 27	68.3

(3) KDB789033 D02 v02r01 G)2)c)

- (i) Sections 15.407(b)(1-3) specifies the unwanted emissions limit for the U-NII-1 and U-NII-2 bands. As specified, emissions above 1000 MHz that are outside of the restricted bands are subject to a peak emission limit of -27 dBm/MHz.
- (ii) Section 15.407(b)(4) specifies the unwanted emissions limit for the U-NII-3 band. A band emissions mask is specified in Section 15.407(b)(4)(i). The emission limits are based on the use of a peak detector.

### 3.4.2 Measuring Instruments

See list of measuring equipment of this test report.

### 3.4.3 Test Procedures

1. The testing follows FCC KDB 789033 D02 General UNII Test Procedures New Rules v02r01. Section G) Unwanted emissions measurement.

(1) Procedure for Unwanted Emissions Measurements Below 1000MHz

- RBW = 120 kHz
- VBW = 300 kHz
- Detector = Peak
- Trace mode = max hold

(2) Procedure for Peak Unwanted Emissions Measurements Above 1000 MHz

- RBW = 1 MHz
- VBW ≥ 3 MHz
- Detector = Peak
- Sweep time = auto
- Trace mode = max hold

(3) Procedures for Average Unwanted Emissions Measurements Above 1000MHz

- RBW = 1 MHz
- VBW = 10 Hz, when duty cycle is no less than 98 percent.
- VBW ≥ 1/T, when duty cycle is less than 98 percent where T is the minimum transmission duration over which the transmitter is on and is transmitting at its maximum power control level for the tested mode of operation.



2. The EUT was placed on a turntable with 0.8 meter for frequency below 1GHz and 1.5 meter for frequency above 1GHz respectively above ground.
3. The EUT was set 3 meters from the interference receiving antenna which was mounted on the top of a variable height antenna tower.
4. The antenna is a broadband antenna and its height is adjusted between one meter and four meters above ground to find the maximum value of the field strength for both horizontal polarization and vertical polarization of the antenna.
5. For each suspected emission, the EUT was arranged to its worst case and then adjust the antenna tower (from 1 m to 4 m) and turntable (from 0 degree to 360 degrees) to find the maximum reading.
6. For testing below 1GHz, if the emission level of the EUT in peak mode was 3 dB lower than the limit specified, then peak values of EUT will be reported, otherwise, the emissions will be repeated one by one using the CISPR quasi-peak method and reported.
7. For testing above 1GHz, the emission level of the EUT in peak mode was 20dB lower than average limit (that means the emission level in average mode also complies with the limit in average mode), then peak values of EUT will be reported, otherwise, the emissions will be measured in average mode again and reported.

### 3.4.4 Test Setup

For radiated emissions below 30MHz

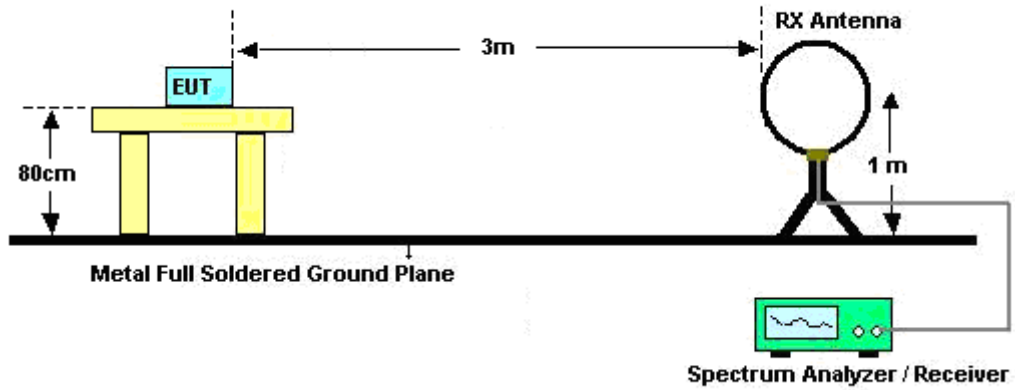

For radiated emissions from 30MHz to 1GHz

<CDD Mode>

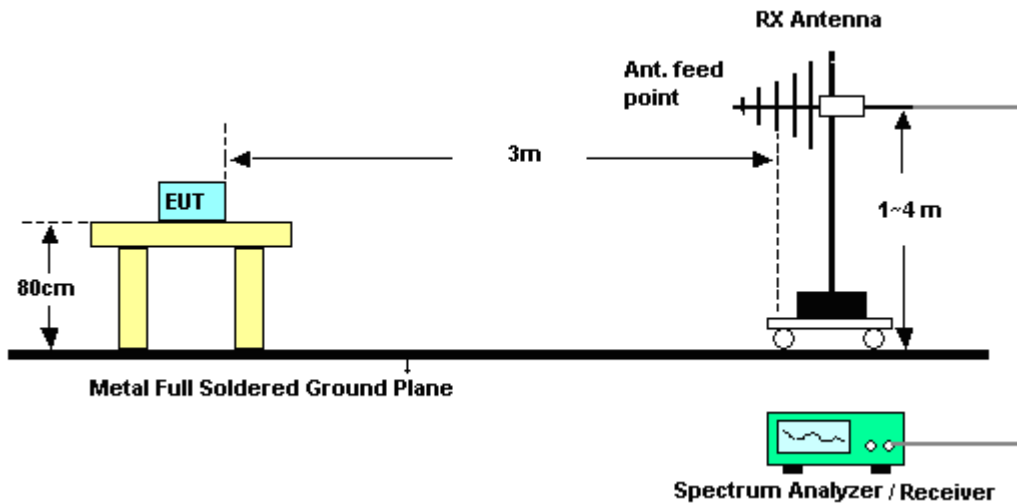

<TXBF Modes>

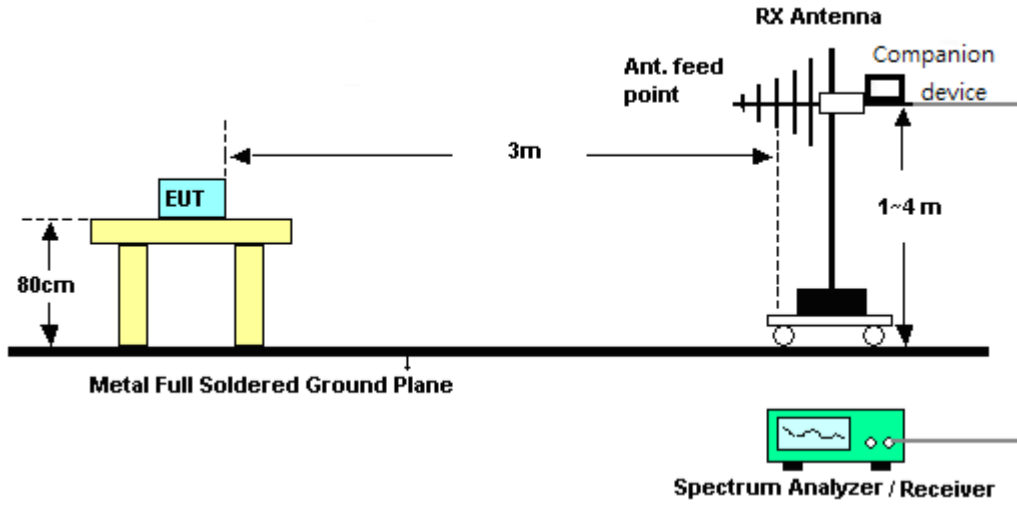

For radiated emissions above 1GHz

<CDD Mode>

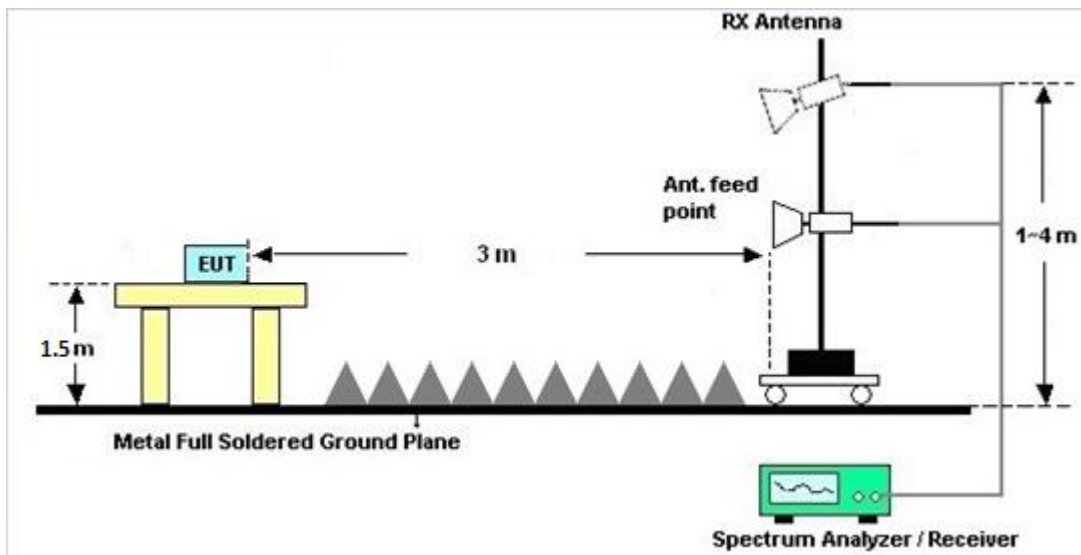

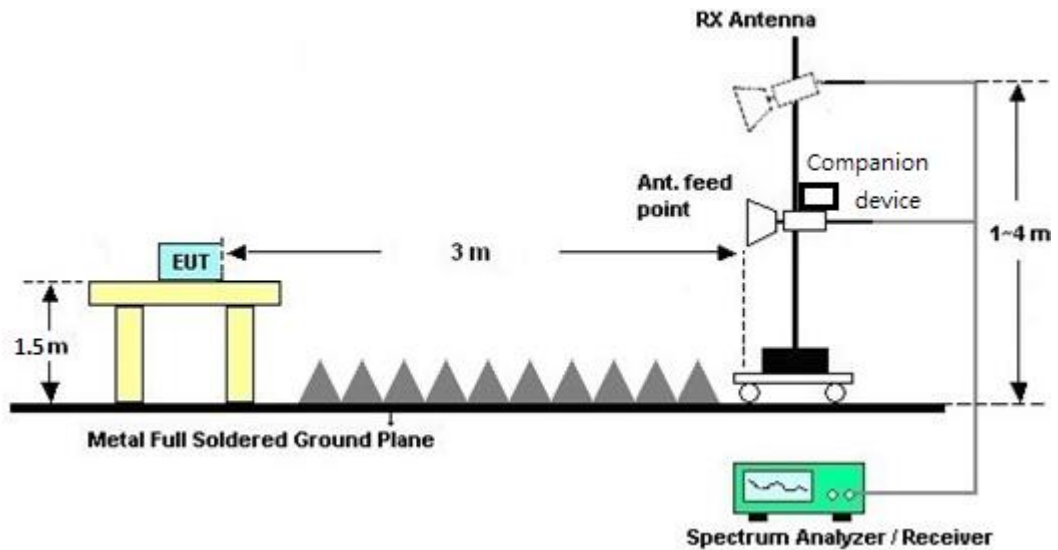
**<TXBF Modes>****3.4.5 Test Results of Radiated Emissions (9 kHz ~ 30 MHz)**

The low frequency, which started from 9 kHz to 30MHz, was pre-scanned and the result which was 20dB lower than the limit line was not reported.

There is a comparison data of both open-field test site and alternative test site - semi-Anechoic chamber according to 414788 D01 Radiated Test Site v01r01, and the result came out very similar.

**3.4.6 Test Result of Radiated Band Edges**

Please refer to Appendix C and D.

**3.4.7 Duty Cycle**

Please refer to Appendix E.

**3.4.8 Test Result of Unwanted Radiated Emission (30MHz ~ 10th Harmonic)**

Please refer to Appendix C and D.



### 3.5 AC Conducted Emission Measurement

#### 3.5.1 Limit of AC Conducted Emission

For equipment that is designed to be connected to the public utility (AC) power line, the radio frequency voltage that is conducted back onto the AC power line on any frequency or frequencies within the band 150 kHz to 30 MHz shall not exceed the limits in the following table.

Frequency of emission (MHz)	Conducted limit (dB $\mu$ V)	
	Quasi-peak	Average
0.15-0.5	66 to 56*	56 to 46*
0.5-5	56	46
5-30	60	50

\*Decreases with the logarithm of the frequency.

#### 3.5.2 Measuring Instruments

See list of measuring equipment of this test report.

#### 3.5.3 Test Procedures

1. The EUT was placed 0.4 meter from the conducting wall of the shielding room was kept at least 80 centimeters from any other grounded conducting surface.
2. Connect EUT to the power mains through a line impedance stabilization network (LISN).
3. All the support units are connecting to the other LISN.
4. The LISN provides 50 ohm coupling impedance for the measuring instrument.
5. The FCC states that a 50 ohm, 50 microhenry LISN should be used.
6. Both sides of AC line were checked for maximum conducted interference.
7. The frequency range from 150 kHz to 30 MHz was searched.
8. Set the test-receiver system to Peak Detect Function and specified bandwidth with Maximum Hold Mode.

### 3.5.4 Test Setup

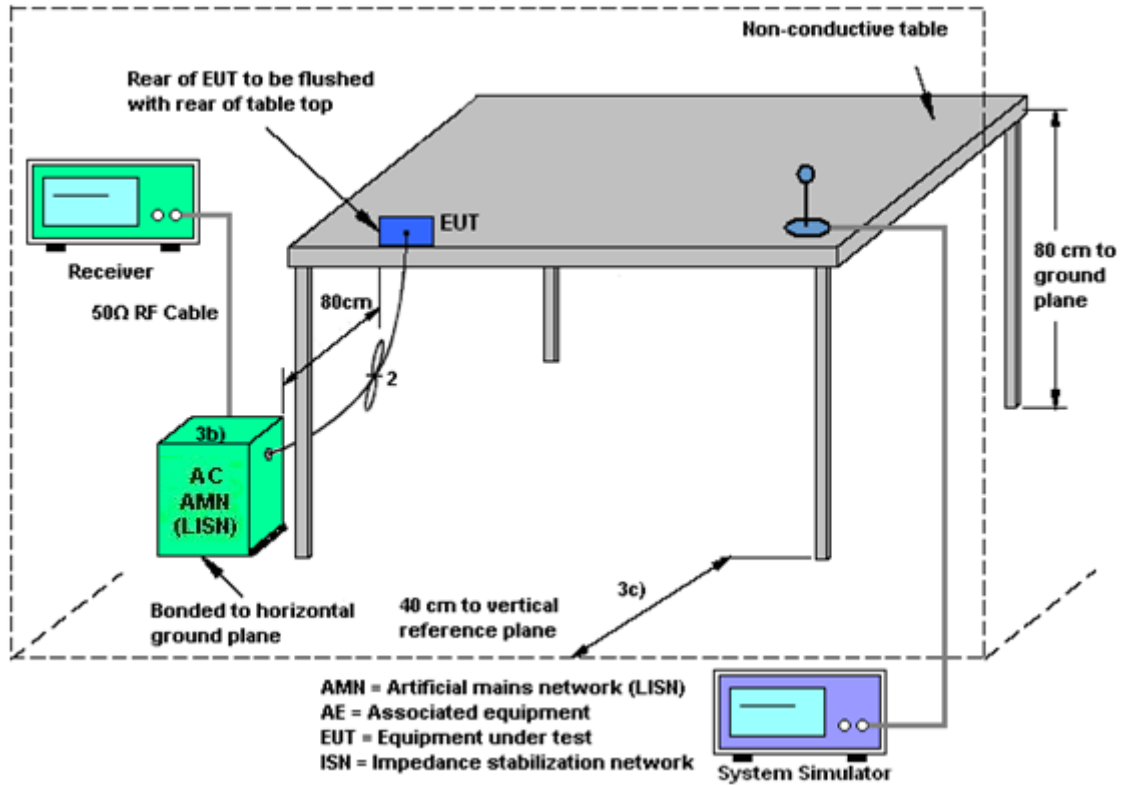

### 3.5.5 Test Result of AC Conducted Emission

Please refer to Appendix B.



## **3.6 Automatically Discontinue Transmission**

### **3.6.1 Limit of Automatically Discontinue Transmission**

The device shall automatically discontinue transmission in case of either absence of information to transmit or operational failure. These provisions are not intended to preclude the transmission of control or signaling information or the use of repetitive codes used by certain digital technologies to complete frame or burst intervals. Applicants shall include in their application for equipment authorization to describe how this requirement is met.

### **3.6.2 Measuring Instruments**

See list of measuring equipment of this test report.

### **3.6.3 Test Result of Automatically Discontinue Transmission**

EUT is verified this characteristic during the function check of normal sample associated with an access point:

- A. Information start: make EUT supply information to the access point.
- B. Information stop: stop supplying information to the access point.

While the EUT is not transmitting any information, the EUT can automatically discontinue transmission and become standby mode for power saving.

- C. Information start: make EUT supply information to the access point again.

The EUT can detect the controlling signal of ACK message transmitting from remote device and verify whether it shall resend or discontinue transmission.

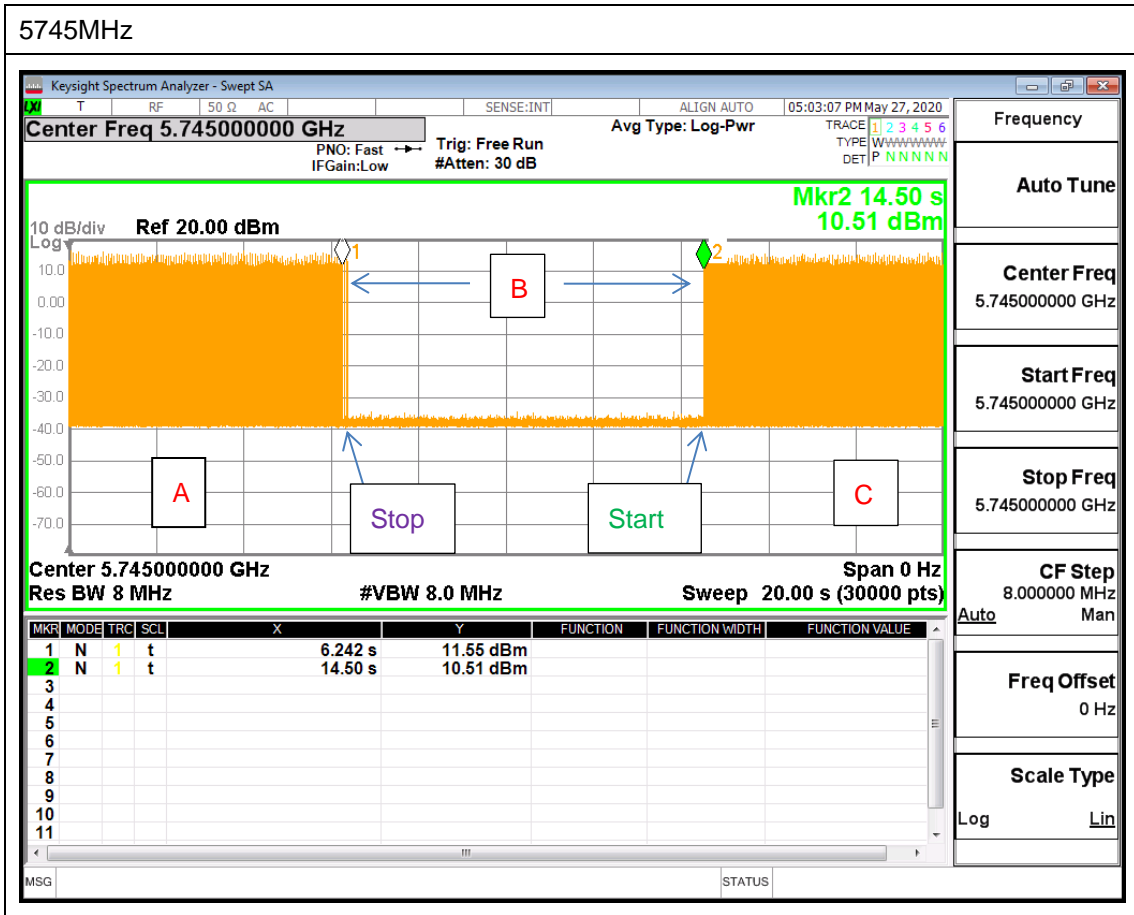

Note : The control / signalling information during the period B is precluded.



### 3.7 Antenna Requirements

#### 3.7.1 Standard Applicable

If transmitting antenna directional gain is greater than 6 dBi, both the peak transmit power and the peak power spectral density shall be reduced by the amount in dB that the directional gain of the antenna exceeds 6 dBi.

#### 3.7.2 Antenna Anti-Replacement Construction

An embedded-in antenna design is used.

#### 3.7.3 Antenna Gain

<CDD Modes >

FCC KDB 662911 D01 Multiple Transmitter Output v02r01

For CDD transmissions, directional gain is calculated as

Directional gain = GANT + Array Gain, where Array Gain is as follows.

For power spectral density (PSD) measurements on all devices,

Array Gain = 10 log(NANT/NSS=1) dB.

For power measurements on IEEE 802.11 devices,

Array Gain = 0 dB (i.e., no array gain) for NANT ≤ 4.

Directional gain may be calculated by using the formulas applicable to equal gain antennas with GANT set equal to the gain of the antenna having the highest gain;

The EUT supports CDD mode.

For power, the directional gain GANT is set equal to the antenna having the highest gain, i.e., F)2)f)i).

For PSD, the directional gain calculation is following F)2)f)ii) of KDB 662911 D01 v02r01.

The power and PSD limit should be modified if the directional gain of EUT is over 6 dBi,

The directional gain "DG" is calculated as following table.

<CDD Modes>						
			DG	DG	Power	PSD
			for	for	Limit	Limit
	Ant. 4	Ant. 3	Power	PSD	Reduction	Reduction
	(dBi)	(dBi)	(dBi)	(dBi)	(dB)	(dB)
Band IV	0.20	1.00	1.00	3.62	0.00	0.00

Power Limit Reduction = DG(Power) – 6dBi, ( min = 0 )

PSD Limit Reduction = DG(PSD) – 6dBi, ( min = 0 )

**TXBF modes**

FCC KDB 662911 D01 Multiple Transmitter Output v02r01

For CDD transmissions, directional gain is calculated as

$$DirectionalGain = 10 \cdot \log \left[ \frac{\sum_{j=1}^{N_{SS}} \left\{ \sum_{k=1}^{N_{ANT}} g_{j,k} \right\}^2}{N_{ANT}} \right]$$

where

Each antenna is driven by no more than one spatial stream;

$N_{SS}$  = the number of independent spatial streams of data;

$N_{ANT}$  = the total number of antennas

$g_{j,k} = 10^{G_k / 20}$  if the  $k$ th antenna is being fed by spatial stream  $j$ , or zero if it is not;  
 $G_k$  is the gain in dBi of the  $k$ th antenna.

The EUT supports beamforming for 802.11ac modes.

The directional gain calculation is following F)2)e)ii) of KDB 662911 D01 v02r01.

The power and PSD limit should be modified if the directional gain of EUT is over 6 dBi,

The directional gain “DG” is calculated as following table.

			DG	DG	Power	PSD
			for	for	Limit	Limit
	Ant 4	Ant 3	Power	PSD	Reduction	Reduction
	(dBi)	(dBi)	(dBi)	(dBi)	(dB)	(dB)
<b>Band IV</b>	0.20	1.00	3.62	3.62	0.00	0.00

$Power\ Limit\ Reduction = DG(Power) - 6dBi, (min = 0)$

$PSD\ Limit\ Reduction = DG(PSD) - 6dBi, (min = 0)$



## 4 List of Measuring Equipment

Instrument	Manufacturer	Model No.	Serial No.	Characteristics	Calibration Date	Test Date	Due Date	Remark
AC Power Source	ChainTek	APC-1000W	N/A	N/A	N/A	May 23, 2020	N/A	Conduction (CO05-HY)
EMI Test Receiver	Rohde & Schwarz	ESR3	102388	9kHz~3.6GHz	Nov. 15, 2019	May 23, 2020	Nov. 14, 2020	Conduction (CO05-HY)
Hygrometer	Testo	608-H1	34913912	N/A	Nov. 07, 2019	May 23, 2020	Nov. 06, 2020	Conduction (CO05-HY)
LISN	Rohde & Schwarz	ENV216	100081	9kHz~30MHz	Nov. 15, 2019	May 23, 2020	Nov. 14, 2020	Conduction (CO05-HY)
Software	Rohde & Schwarz	EMC32 V10.30	N/A	N/A	N/A	May 23, 2020	N/A	Conduction (CO05-HY)
LF Cable	HUBER + SUHNER	RG-214/U	LF01	N/A	Jan. 02, 2020	May 23, 2020	Jan. 01, 2021	Conduction (CO05-HY)
Pulse Limiter	Rohde & Schwarz	ESH3-Z2	100851	N/A	Jan. 02, 2020	May 23, 2020	Jan. 01, 2021	Conduction (CO05-HY)
Loop Antenna	Rohde & Schwarz	HFH2-Z2	100488	9 kHz~30 MHz	Jan. 09, 2020	May 30, 2020~Jul. 01, 2020	Jan. 08, 2021	Radiation (03CH15-HY)
Bilog Antenna	TESEQ	CBL6111D&00800N1D01N-06	41912&05	30MHz to 1GHz	Feb. 09, 2020	May 30, 2020~Jul. 01, 2020	Feb. 08, 2021	Radiation (03CH15-HY)
Amplifier	SONOMA	310N	363440	9kHz~1GHz	Dec. 27, 2019	May 30, 2020~Jul. 01, 2020	Dec. 26, 2020	Radiation (03CH15-HY)
Horn Antenna	SCHWARZBECK	BBHA 9120 D	9120D-1620	1-18GHz	Oct. 28, 2019	May 30, 2020~Jul. 01, 2020	Oct. 27, 2020	Radiation (03CH15-HY)
SHF-EHF Horn Antenna	SCHWARZBECK	BBHA 9170	BBHA9170584	18GHz- 40GHz	Dec. 10, 2019	May 30, 2020~Jul. 01, 2020	Dec. 09, 2020	Radiation (03CH15-HY)
Preamplifier	Jet-Power	JPA0118-55-303	1710001800055006	1GHz~18GHz	May 07, 2020	May 30, 2020~Jul. 01, 2020	May 06, 2021	Radiation (03CH15-HY)
Preamplifier	Keysight	83017A	MY53270195	1GHz~26.5GHz	Aug. 23, 2019	May 30, 2020~Jul. 01, 2020	Aug. 22, 2020	Radiation (03CH15-HY)
Preamplifier	EMEC	EM18G40G	060715	18GHz ~ 40GHz	Dec. 13, 2019	May 30, 2020~Jul. 01, 2020	Dec. 12, 2020	Radiation (03CH15-HY)
EMI Test Receiver	Keysight	N9038A(MXE)	MY54130085	20MHz~8.4GHz	Nov. 01, 2019	May 30, 2020~Jul. 01, 2020	Oct. 31, 2020	Radiation (03CH15-HY)
Spectrum Analyzer	Agilent	E4446A	MY50180136	3Hz~44GHz	May 04, 2020	May 30, 2020~Jul. 01, 2020	May 03, 2021	Radiation (03CH15-HY)
Antenna Mast	ChainTek	MBS-520-1	N/A	1m~4m	N/A	May 30, 2020~Jul. 01, 2020	N/A	Radiation (03CH15-HY)
Turn Table	ChainTek	T-200-S-1	N/A	0~360 Degree	N/A	May 30, 2020~Jul. 01, 2020	N/A	Radiation (03CH15-HY)
Software	Audix	E3 6.2009-8-24(k5)	RK-000451	N/A	N/A	May 30, 2020~Jul. 01, 2020	N/A	Radiation (03CH15-HY)
RF Cable	HUBER + SUHNER	SUCOFLEX 104	MY36980/4	30M-18G	Apr. 14, 2020	May 30, 2020~Jul. 01, 2020	Apr. 13, 2021	Radiation (03CH15-HY)
RF Cable	HUBER + SUHNER	SUCOFLEX 104	MY9838/4PE	30M-18G	Apr. 14, 2020	May 30, 2020~Jul. 01, 2020	Apr. 13, 2021	Radiation (03CH15-HY)
RF Cable	HUBER + SUHNER	SUCOFLEX 104	MY37710/4	30M-18G	Apr. 17, 2020	May 30, 2020~Jul. 01, 2020	Apr. 16, 2021	Radiation (03CH15-HY)
RF Cable	HUBER + SUHNER	SUCOFLEX 102	505134/2	30MHz-40GHz	Feb. 25, 2020	May 30, 2020~Jul. 01, 2020	Feb. 24, 2021	Radiation (03CH15-HY)
RF Cable	HUBER + SUHNER	SUCOFLEX 102	800740/2	30MHz-40GHz	Feb. 25, 2020	May 30, 2020~Jul. 01, 2020	Feb. 24, 2021	Radiation (03CH15-HY)
Filter	Wainwright	WLK4-1000-1530-8000-40S	SN4	1.53G Low Pass	Jul. 04, 2019	May 30, 2020~Jul. 01, 2020	Jul. 03, 2020	Radiation (03CH15-HY)
Filter	Wainwright	WHKX8-5872.5-6750-18000-40ST	SN6	6.75GHz High Pass Filter	Jul. 04, 2019	May 30, 2020~Jul. 01, 2020	Jul. 03, 2020	Radiation (03CH15-HY)



Instrument	Manufacturer	Model No.	Serial No.	Characteristics	Calibration Date	Test Date	Due Date	Remark
Power Sensor	DARE	RPR3006W	16I00054S NO10	10MHz~6GHz	Dec. 23, 2019	May 07, 2020~ Jul. 08, 2020	Dec. 22, 2020	Conducted (TH05-HY)
Switch Box & RF Cable	Burgeon	ETF-058	EC130048 4	N/A	Aug. 22, 2019	May 07, 2020~ Jul. 08, 2020	Aug. 21, 2020	Conducted (TH05-HY)
Hygrometer	Testo	HTC-1	2	N/A	Mar. 02, 2020	May 07, 2020~ Jul. 08, 2020	Mar. 01, 2021	Conducted (TH05-HY)
Signal Analyzer	Rohde & Schwarz	FSV40	101566	10Hz~40GHz	Jul. 15, 2019	May 07, 2020~ Jul. 08, 2020	Jul. 14, 2020	Conducted (TH05-HY)
Power Supply	GW Instek	SPS-606	GES84293 1	NA	Aug. 19, 2019	May 07, 2020~ Jul. 08, 2020	Aug. 18, 2020	Conducted (TH05-HY)
Spectrum Analyzer	Rohde & Schwarz	FSP40	100055	9kHz-40GHz	Dec. 30, 2019	May 15, 2020~ Jul. 07, 2020	Dec. 29, 2020	Conducted (TH05-HY)
Spectrum Analyzer	Keysight	N9010A	MY560704 12	10Hz~7GHz	Aug. 27, 2019	May. 27, 2020	Aug. 26, 2020	Conducted (TH05-HY)



## 5 Uncertainty of Evaluation

### Uncertainty of Conducted Emission Measurement (150kHz ~ 30MHz)

Measuring Uncertainty for a Level of Confidence of 95% ( $U = 2Uc(y)$ )	2.3
---	-----

### Uncertainty of Radiated Emission Measurement (30 MHz ~ 1000 MHz)

Measuring Uncertainty for a Level of Confidence of 95% ( $U = 2Uc(y)$ )	5.0
---	-----

### Uncertainty of Radiated Emission Measurement (1000 MHz ~ 18000 MHz)

Measuring Uncertainty for a Level of Confidence of 95% ( $U = 2Uc(y)$ )	5.4
---	-----

### Uncertainty of Radiated Emission Measurement (18000 MHz ~ 40000 MHz)

Measuring Uncertainty for a Level of Confidence of 95% ( $U = 2Uc(y)$ )	5.0
---	-----

**Appendix A. Test Result of Conducted Test Items****<CDD Mode>**

Test Engineer:	Kai Liao/Derek Hsu	Temperature:	21.2~24.1	°C
Test Date:	2020/5/15~2020/06/25	Relative Humidity:	47.2~57.8	%

**TEST RESULTS DATA**  
**6dB and 26dB EBW and 99% OBW**

Band IV MIMO												
Mod.	Data Rate	NTX	CH.	Freq. (MHz)	99% Bandwidth (MHz)		26dB Bandwidth (MHz)		6 dB Bandwidth (MHz)		6 dB Bandwidth Min. Limit (MHz)	Pass/Fail
					Ant 4	Ant 3	Ant 4	Ant 3	Ant 4	Ant 3		
11a	6Mbps	2	149	5745	17.18	25.72	27.10	42.50	15.90	16.25	0.5	Pass
11a	6Mbps	2	157	5785	17.38	24.13	28.80	41.60	15.25	16.30	0.5	Pass
11a	6Mbps	2	165	5825	17.48	25.82	29.20	43.70	15.95	16.30	0.5	Pass
HT20	MCS0	2	149	5745	18.08	22.98	27.60	40.90	15.30	16.50	0.5	Pass
HT20	MCS0	2	157	5785	18.33	21.28	29.35	37.90	15.65	16.90	0.5	Pass
HT20	MCS0	2	165	5825	18.23	20.13	29.75	34.90	15.70	15.70	0.5	Pass
HT40	MCS0	2	151	5755	36.66	37.36	42.39	66.87	35.46	35.10	0.5	Pass
HT40	MCS0	2	159	5795	36.66	37.76	42.48	76.95	35.28	35.64	0.5	Pass
VHT80	MCS0	2	155	5775	76.84	77.32	84.96	117.44	75.20	75.20	0.5	Pass

**TEST RESULTS DATA**  
**Average Power Table**

Band IV MIMO												
Mod.	Data Rate	NTX	CH.	Freq. (MHz)	Average Conducted Power (dBm)			FCC Conducted Power Limit (dBm)		DG (dBi)		Pass/Fail
					Ant 4	Ant 3	SUM	Ant 4	Ant 3	Ant 4	Ant 3	
11a	6Mbps	2	149	5745	19.70	20.90	23.35	30.00	30.00	1.00	1.00	Pass
11a	6Mbps	2	157	5785	19.90	20.80	23.38	30.00	30.00	1.00	1.00	Pass
11a	6Mbps	2	165	5825	19.80	20.80	23.34	30.00	30.00	1.00	1.00	Pass
HT20	MCS0	2	149	5745	19.30	20.50	22.95	30.00	30.00	1.00	1.00	Pass
HT20	MCS0	2	157	5785	19.40	20.40	22.94	30.00	30.00	1.00	1.00	Pass
HT20	MCS0	2	165	5825	19.10	20.20	22.70	30.00	30.00	1.00	1.00	Pass
HT40	MCS0	2	151	5755	19.00	20.10	22.60	30.00	30.00	1.00	1.00	Pass
HT40	MCS0	2	159	5795	19.20	20.00	22.63	30.00	30.00	1.00	1.00	Pass
VHT20	MCS0	2	149	5745	19.30	20.40	22.90	30.00	30.00	1.00	1.00	Pass
VHT20	MCS0	2	157	5785	19.40	20.30	22.88	30.00	30.00	1.00	1.00	Pass
VHT20	MCS0	2	165	5825	19.10	20.10	22.64	30.00	30.00	1.00	1.00	Pass
VHT40	MCS0	2	151	5755	18.70	19.60	22.18	30.00	30.00	1.00	1.00	Pass
VHT40	MCS0	2	159	5795	18.70	19.70	22.24	30.00	30.00	1.00	1.00	Pass
VHT80	MCS0	2	155	5775	18.40	19.40	21.94	30.00	30.00	1.00	1.00	Pass

**TEST RESULTS DATA**  
**Power Spectral Density**

Band IV MIMO														
Mod.	Data Rate	NTX	CH.	Freq. (MHz)	10log (500kHz /RBW) Factor (dB)		Average Power Density (dBm/500kHz)			Average PSD Limit (dBm/500kHz)		DG (dBi)		Pass /Fail
					Ant 4	Ant 3	Ant 4	Ant 3	SUM	Ant 4	Ant 3	Ant 4	Ant 3	
11a	6Mbps	2	149	5745	2.22		11.27	12.12	15.13	30.00		3.62		Pass
11a	6Mbps	2	157	5785	2.22		10.95	11.80	14.81	30.00		3.62		Pass
11a	6Mbps	2	165	5825	2.22		11.08	12.29	15.30	30.00		3.62		Pass
HT20	MCS0	2	149	5745	2.22		10.57	11.44	14.45	30.00		3.62		Pass
HT20	MCS0	2	157	5785	2.22		10.43	11.12	14.13	30.00		3.62		Pass
HT20	MCS0	2	165	5825	2.22		10.70	11.05	14.06	30.00		3.62		Pass
HT40	MCS0	2	151	5755	2.22		6.29	7.53	10.54	30.00		3.62		Pass
HT40	MCS0	2	159	5795	2.22		6.56	7.67	10.68	30.00		3.62		Pass
VHT80	MCS0	2	155	5775	2.22		2.99	5.06	8.07	30.00		3.62		Pass

Note: PSD Sum = Max PSD(Ant. 4, Ant. 3) + 10 log (n)

## &lt;TXBF Mode&gt;

Test Engineer:	Ryan	Temperature:	21.2~24.1	°C
Test Date:	2020/5/22~2020/07/08	Relative Humidity:	47.2~57.8	%

**TEST RESULTS DATA**  
**6dB and 26dB EBW and 99% OBW**

Band IV MIMO												
Mod.	Data Rate	NTX	CH.	Freq. (MHz)	99% Bandwidth (MHz)		26dB Bandwidth (MHz)		6 dB Bandwidth (MHz)		6 dB Bandwidth Min. Limit (MHz)	Pass/Fail
					Ant 4	Ant 3	Ant 4	Ant 3	Ant 4	Ant 3		
VHT20	MCS0	2	149	5745	17.88	18.08	24.35	25.55	15.15	17.70	0.5	Pass
VHT20	MCS0	2	157	5785	17.78	17.98	25.40	25.15	16.20	17.60	0.5	Pass
VHT20	MCS0	2	165	5825	16.68	16.68	24.50	25.00	16.40	15.40	0.5	Pass
VHT40	MCS0	2	151	5755	37.16	37.26	43.74	44.46	35.37	35.28	0.5	Pass
VHT40	MCS0	2	159	5795	36.86	37.06	43.38	45.36	35.01	35.64	0.5	Pass
VHT80	MCS0	2	155	5775	78.04	77.80	82.72	82.56	75.84	75.84	0.5	Pass

**TEST RESULTS DATA**  
**Average Power Table**

Band IV MIMO												
Mod.	Data Rate	NTX	CH.	Freq. (MHz)	Average Conducted Power (dBm)			FCC Conducted Power Limit (dBm)		DG (dBi)		Pass/Fail
					Ant 4	Ant 3	SUM	Ant 4	Ant 3	Ant 4	Ant 3	
VHT20	MCS0	2	149	5745	15.40	16.30	18.88	30.00		3.62		Pass
VHT20	MCS0	2	157	5785	16.00	16.60	19.32	30.00		3.62		Pass
VHT20	MCS0	2	165	5825	16.90	17.30	20.11	30.00		3.62		Pass
VHT40	MCS0	2	151	5755	16.10	17.90	20.10	30.00		3.62		Pass
VHT40	MCS0	2	159	5795	15.70	16.60	19.18	30.00		3.62		Pass
VHT80	MCS0	2	155	5775	16.80	17.10	19.96	30.00		3.62		Pass

**TEST RESULTS DATA**  
**Power Spectral Density**

Band IV MIMO														
Mod.	Data Rate	NTX	CH.	Freq. (MHz)	10log (500kHz /RBW) Factor (dB)		Average Power Density (dBm/500kHz)			Average PSD Limit (dBm/500kHz)		DG (dBi)		Pass /Fail
					Ant 4	Ant 3	Ant 4	Ant 3	SUM	Ant 4	Ant 3	Ant 4	Ant 3	
VHT20	MCS0	2	149	5745	2.22	8.29	9.56	12.57		30.00		3.62	Pass	
VHT20	MCS0	2	157	5785	2.22	8.90	9.65	12.66		30.00		3.62	Pass	
VHT20	MCS0	2	165	5825	2.22	8.77	9.12	12.13		30.00		3.62	Pass	
VHT40	MCS0	2	151	5755	2.22	7.79	8.43	11.44		30.00		3.62	Pass	
VHT40	MCS0	2	159	5795	2.22	8.68	9.63	12.64		30.00		3.62	Pass	
VHT80	MCS0	2	155	5775	2.22	8.46	8.64	11.65		30.00		3.62	Pass	

Note: PSD Sum = Max PSD(Ant. 4, Ant. 3) + 10 log (n)



## Appendix B. AC Conducted Emission Test Results

Test Engineer :	Tom Lee	Temperature :	21~24°C
		Relative Humidity :	42~50%

# EUT Information

Report NO : 051232  
 Test Mode : Mode 1  
 Test Voltage : 120Vac/60Hz  
 Phase : Line

Full Spectrum

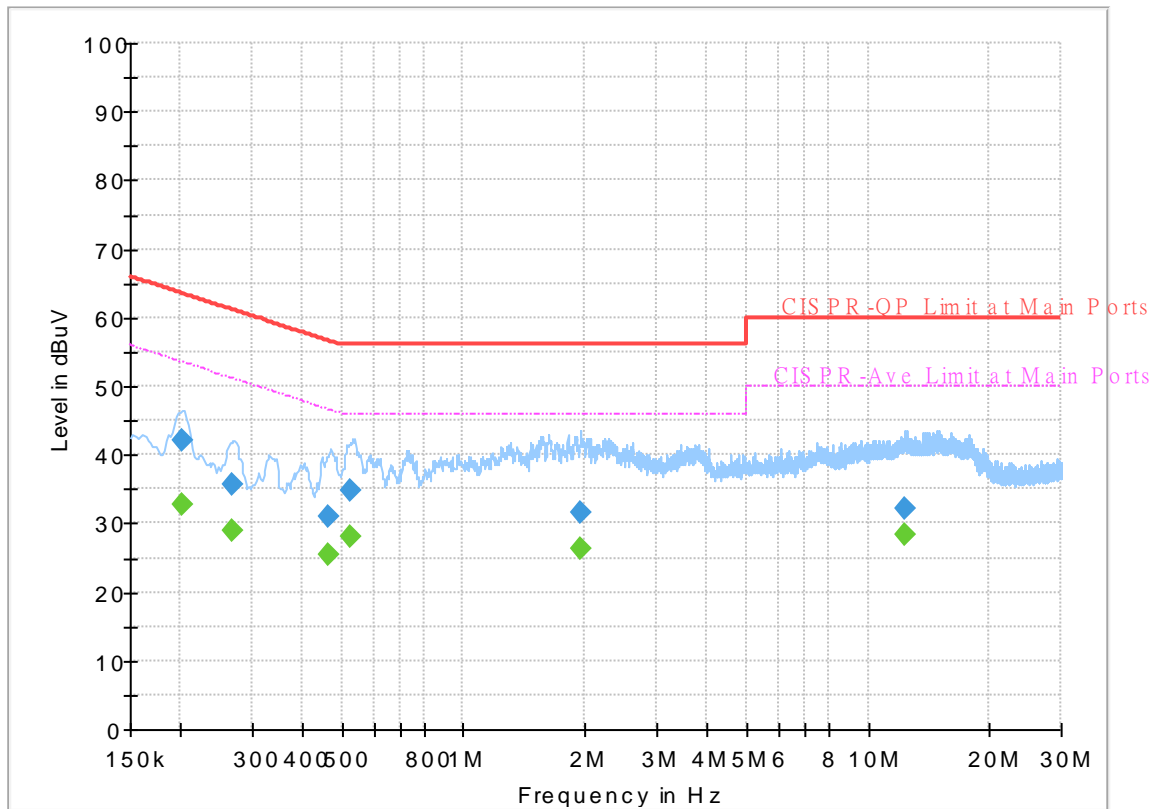

## Final\_Result

Frequency (MHz)	QuasiPeak (dBuV)	CAverage (dBuV)	Limit (dBuV)	Margin (dB)	Line	Filter	Corr. (dB)
0.201750	---	32.77	53.54	20.77	L1	OFF	19.6
0.201750	42.09	---	63.54	21.45	L1	OFF	19.6
0.267450	---	29.00	51.20	22.20	L1	OFF	19.6
0.267450	35.55	---	61.20	25.65	L1	OFF	19.6
0.465000	---	25.48	46.60	21.12	L1	OFF	19.6
0.465000	31.06	---	56.60	25.54	L1	OFF	19.6
0.528000	---	28.14	46.00	17.86	L1	OFF	19.6
0.528000	34.81	---	56.00	21.19	L1	OFF	19.6
1.947660	---	26.39	46.00	19.61	L1	OFF	19.6
1.947660	31.64	---	56.00	24.36	L1	OFF	19.6
12.340410	---	28.45	50.00	21.55	L1	OFF	20.2
12.340410	32.30	---	60.00	27.70	L1	OFF	20.2

# EUT Information

Report NO : 051232  
 Test Mode : Mode 1  
 Test Voltage : 120Vac/60Hz  
 Phase : Neutral

Full Spectrum

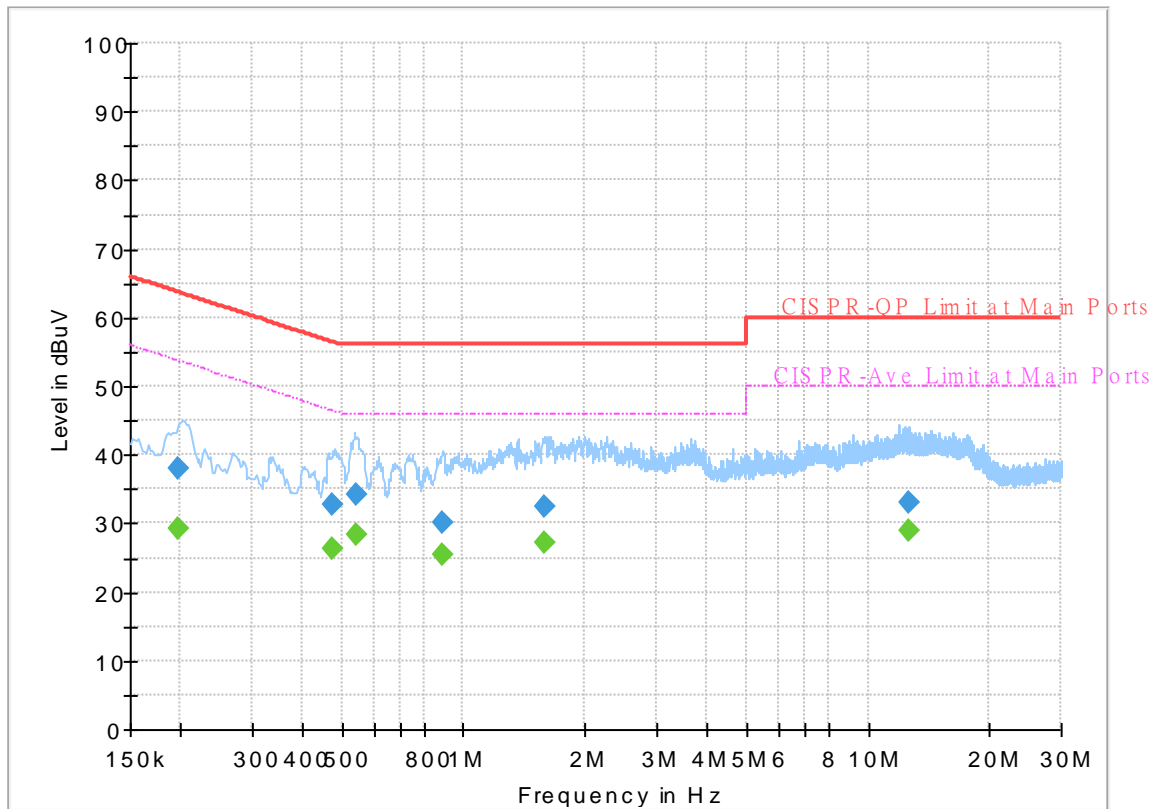

## Final\_Result

Frequency (MHz)	QuasiPeak (dBuV)	CAverage (dBuV)	Limit (dBuV)	Margin (dB)	Line	Filter	Corr. (dB)
0.196800	---	29.34	53.75	24.41	N	OFF	19.6
0.196800	38.12	---	63.75	25.63	N	OFF	19.6
0.476250	---	26.36	46.40	20.04	N	OFF	19.6
0.476250	32.87	---	56.40	23.53	N	OFF	19.6
0.541500	---	28.39	46.00	17.61	N	OFF	19.6
0.541500	34.12	---	56.00	21.88	N	OFF	19.6
0.886380	---	25.50	46.00	20.50	N	OFF	19.6
0.886380	30.10	---	56.00	25.90	N	OFF	19.6
1.593600	---	27.22	46.00	18.78	N	OFF	19.6
1.593600	32.56	---	56.00	23.44	N	OFF	19.6
12.657660	---	29.01	50.00	20.99	N	OFF	20.2
12.657660	32.98	---	60.00	27.02	N	OFF	20.2



### Appendix C. Radiated Spurious Emission

Test Engineer :	Leo Lee, Mancy Chou and Bigshow Wang	Temperature :	21.4~22.9°C
		Relative Humidity :	52~61%

<CDD Mode>

**Band 4 - 5725~5850MHz**  
**WIFI 802.11a (Band Edge @ 3m)**

WIFI Ant.	Note	Frequency ( MHz )	Level ( dBμV/m )	Over Limit ( dB )	Limit Line ( dBμV/m )	Read Level ( dBμV )	Antenna Factor ( dB/m )	Path Loss ( dB )	Preamp Factor ( dB )	Ant Pos ( cm )	Table Pos ( deg )	Peak Avg. ( P/A )	Pol. ( H/V )	
802.11a CH 149 5745MHz		5627.8	52.87	-15.33	68.2	40.65	31.84	10.89	30.51	100	98	P	H	
		5696	53.99	-48.26	102.25	41.69	31.98	10.87	30.55	100	98	P	H	
		5718.6	65.8	-44.61	110.41	53.5	32	10.87	30.57	100	98	P	H	
		5724.6	76.93	-44.36	121.29	64.63	32	10.87	30.57	100	98	P	H	
	*	5745	112.83	-	-	100.55	32	10.86	30.58	100	98	P	H	
	*	5745	103.7	-	-	91.42	32	10.86	30.58	100	98	A	H	
														H
														H
			5637.6	52.64	-15.56	68.2	40.45	31.82	10.89	30.52	103	4	P	V
			5695	54.34	-47.17	101.51	42.03	31.98	10.88	30.55	103	4	P	V
			5717.4	67.94	-42.13	110.07	55.63	32	10.87	30.56	103	4	P	V
			5722.6	79.88	-36.85	116.73	67.58	32	10.87	30.57	103	4	P	V
	*	5745	114.85	-	-	102.57	32	10.86	30.58	103	4	P	V	
	*	5745	106.15	-	-	93.87	32	10.86	30.58	103	4	A	V	
													V	
													V	



WIFI Ant. 4+3	Note	Frequency ( MHz )	Level ( dBμV/m )	Over Limit ( dB )	Limit Line ( dBμV/m )	Read Level ( dBμV )	Antenna Factor ( dB/m )	Path Loss ( dB )	Preamp Factor ( dB )	Ant Pos ( cm )	Table Pos ( deg )	Peak Avg. ( P/A )	Pol. ( H/V )	
802.11a CH 157 5785MHz		5600.6	52.82	-15.38	68.2	40.51	31.9	10.9	30.49	100	56	P	H	
		5672.6	52	-32.96	84.96	39.77	31.89	10.88	30.54	100	56	P	H	
		5718.8	52.29	-58.17	110.46	39.99	32	10.87	30.57	100	56	P	H	
		5723.4	51.69	-66.86	118.55	39.39	32	10.87	30.57	100	56	P	H	
	*	5785	112.29	-	-	99.91	32.14	10.85	30.61	100	56	P	H	
	*	5785	103.93	-	-	91.55	32.14	10.85	30.61	100	56	A	H	
		5853.6	52.5	-61.49	113.99	39.95	32.21	10.99	30.65	100	56	P	H	
		5868.2	52.85	-54.25	107.1	40.22	32.27	11.02	30.66	100	56	P	H	
		5908	54.56	-26.18	80.74	41.7	32.42	11.12	30.68	100	56	P	H	
		5941	53.51	-14.69	68.2	40.53	32.48	11.2	30.7	100	56	P	H	
														H
														H
			5620.8	52.54	-15.66	68.2	40.29	31.86	10.89	30.5	100	5	P	V
			5679.2	52.29	-37.56	89.85	40.03	31.92	10.88	30.54	100	5	P	V
			5715	53.11	-56.29	109.4	40.8	32	10.87	30.56	100	5	P	V
			5724.4	52.85	-67.98	120.83	40.55	32	10.87	30.57	100	5	P	V
	*		5785	115.14	-	-	102.76	32.14	10.85	30.61	100	5	P	V
	*		5785	106.76	-	-	94.38	32.14	10.85	30.61	100	5	A	V
			5854.2	53.5	-59.12	112.62	40.94	32.22	10.99	30.65	100	5	P	V
			5867.8	52.88	-54.33	107.21	40.25	32.27	11.02	30.66	100	5	P	V
		5919.2	53.01	-19.47	72.48	40.11	32.44	11.15	30.69	100	5	P	V	
		5940.2	53.05	-15.15	68.2	40.07	32.48	11.2	30.7	100	5	P	V	
													V	
													V	



WiFi Ant. 4+3	Note	Frequency ( MHz )	Level ( dBµV/m )	Over Limit ( dB )	Limit Line ( dBµV/m )	Read Level ( dBµV )	Antenna Factor ( dB/m )	Path Loss ( dB )	Preamp Factor ( dB )	Ant Pos ( cm )	Table Pos ( deg )	Peak Avg. ( P/A )	Pol. ( H/V )	
802.11a CH 165 5825MHz	*	5825	111.87	-	-	99.39	32.2	10.91	30.63	100	56	P	H	
	*	5825	103.68	-	-	91.2	32.2	10.91	30.63	100	56	A	H	
		5852.4	64.07	-52.66	116.73	51.53	32.21	10.98	30.65	100	56	P	H	
		5858	60.9	-49.06	109.96	48.32	32.23	11	30.65	100	56	P	H	
		5876.4	52.81	-51.35	104.16	40.12	32.31	11.04	30.66	100	56	P	H	
		5942	51.78	-16.42	68.2	38.79	32.48	11.21	30.7	100	56	P	H	
														H
														H
	*	5825	114.82	-	-	102.34	32.2	10.91	30.63	100	5	5	P	V
	*	5825	106.25	-	-	93.77	32.2	10.91	30.63	100	5	5	A	V
		5850	70.37	-51.83	122.2	57.84	32.2	10.98	30.65	100	5	5	P	V
		5855.2	65.39	-45.35	110.74	52.83	32.22	10.99	30.65	100	5	5	P	V
		5875.2	55.17	-49.88	105.05	42.49	32.3	11.04	30.66	100	5	5	P	V
		5946	52.05	-16.15	68.2	39.05	32.49	11.22	30.71	100	5	5	P	V
														V
														V
														V
<b>Remark</b>	1. No other spurious found. 2. All results are PASS against Peak and Average limit line.													



**Band 4 5725~5850MHz**  
**WIFI 802.11a (Harmonic @ 3m)**

WIFI Ant. 4+3	Note	Frequency ( MHz )	Level ( dBµV/m )	Over Limit ( dB )	Limit Line ( dBµV/m )	Read Level ( dBµV )	Antenna Factor ( dB/m )	Path Loss ( dB )	Preamp Factor ( dB )	Ant Pos ( cm )	Table Pos ( deg )	Peak Avg. ( P/A )	Pol. ( H/V )	
802.11a CH 149 5745MHz		11490	49.99	-24.01	74	55.56	40.48	14.85	60.9	100	0	P	H	
		17235	51.15	-17.05	68.2	50.36	40.94	18.67	58.82	100	0	P	H	
													H	
													H	
			11490	49.96	-24.04	74	55.53	40.48	14.85	60.9	100	0	P	V
			17235	51.59	-16.61	68.2	50.8	40.94	18.67	58.82	100	0	P	V
														V
802.11a CH 157 5785MHz		11570	49	-25	74	54.78	40.29	14.91	60.98	100	0	P	H	
		17355	52.73	-15.47	68.2	50.86	41.75	18.79	58.67	100	0	P	H	
													H	
													H	
			11565	49.96	-24.04	74	55.73	40.31	14.9	60.98	100	0	P	V
			17355	52.96	-15.24	68.2	51.09	41.75	18.79	58.67	100	0	P	V
														V
802.11a CH 165 5825MHz		11650	49.73	-24.27	74	56	39.85	14.96	61.08	100	0	P	H	
		17475	53.21	-14.99	68.2	50.38	42.5	18.86	58.53	100	0	P	H	
													H	
													H	
			11650	49.28	-24.72	74	55.55	39.85	14.96	61.08	100	0	P	V
			17475	52.88	-15.32	68.2	50.05	42.5	18.86	58.53	100	0	P	V
														V
Remark	1. No other spurious found.													
	2. All results are PASS against Peak and Average limit line.													



**Band 4 5725~5850MHz**  
**WIFI 802.11an HT20 (Band Edge @ 3m)**

WIFI Ant. 4+3	Note	Frequency ( MHz )	Level ( dBμV/m )	Over Limit ( dB )	Limit Line ( dBμV/m )	Read Level ( dBμV )	Antenna Factor ( dB/m )	Path Loss ( dB )	Preamp Factor ( dB )	Ant Pos ( cm )	Table Pos ( deg )	Peak Avg. ( P/A )	Pol. ( H/V )	
802.11an HT20 CH 149 5745MHz		5641	51.91	-16.29	68.2	39.72	31.82	10.89	30.52	100	16	P	H	
		5686.8	52.19	-43.27	95.46	39.91	31.95	10.88	30.55	100	16	P	H	
		5720	65.52	-45.28	110.8	53.22	32	10.87	30.57	100	16	P	H	
		5722.6	75.13	-41.6	116.73	62.83	32	10.87	30.57	100	16	P	H	
	*	5745	112.72	-	-	100.44	32	10.86	30.58	100	16	P	H	
	*	5745	104.77	-	-	92.49	32	10.86	30.58	100	16	A	H	
														H
														H
			5634.2	52.22	-15.98	68.2	40.01	31.83	10.89	30.51	100	355	P	V
			5689.6	53.55	-43.98	97.53	41.26	31.96	10.88	30.55	100	355	P	V
			5720	69.94	-40.86	110.8	57.64	32	10.87	30.57	100	355	P	V
			5724.4	78.92	-41.91	120.83	66.62	32	10.87	30.57	100	355	P	V
	*		5745	115.5	-	-	103.22	32	10.86	30.58	100	355	P	V
	*		5745	107.11	-	-	94.83	32	10.86	30.58	100	355	A	V
														V
														V



WIFI Ant. 4+3	Note	Frequency ( MHz )	Level ( dBµV/m )	Over Limit ( dB )	Limit Line ( dBµV/m )	Read Level ( dBµV )	Antenna Factor ( dB/m )	Path Loss ( dB )	Preamp Factor ( dB )	Ant Pos ( cm )	Table Pos ( deg )	Peak Avg. ( P/A )	Pol. ( H/V )
		5624.4	52.73	-15.47	68.2	40.5	31.85	10.89	30.51	100	57	P	H
		5693.4	51.21	-49.12	100.33	38.91	31.97	10.88	30.55	100	57	P	H
		5719.4	51.02	-59.61	110.63	38.72	32	10.87	30.57	100	57	P	H
		5724.8	50.97	-70.77	121.74	38.67	32	10.87	30.57	100	57	P	H
	*	5785	111.21	-	-	98.83	32.14	10.85	30.61	100	57	P	H
	*	5785	102.84	-	-	90.46	32.14	10.85	30.61	100	57	A	H
		5851.6	50.91	-67.64	118.55	38.37	32.21	10.98	30.65	100	57	P	H
		5863	52.57	-55.99	108.56	39.97	32.25	11.01	30.66	100	57	P	H
		5921.4	52.07	-18.78	70.85	39.16	32.44	11.16	30.69	100	57	P	H
		5932	53.56	-14.64	68.2	40.62	32.46	11.18	30.7	100	57	P	H
802.11an													H
HT20													H
CH 157		5608.4	52.34	-15.86	68.2	40.06	31.88	10.9	30.5	100	20	P	V
5785MHz		5689.4	51.84	-45.54	97.38	39.55	31.96	10.88	30.55	100	20	P	V
		5711.6	51.56	-56.89	108.45	39.25	32	10.87	30.56	100	20	P	V
		5722	51.64	-63.72	115.36	39.34	32	10.87	30.57	100	20	P	V
	*	5785	113.27	-	-	100.89	32.14	10.85	30.61	100	20	P	V
	*	5785	104.84	-	-	92.46	32.14	10.85	30.61	100	20	A	V
		5854.6	51.93	-59.78	111.71	39.37	32.22	10.99	30.65	100	20	P	V
		5859.4	52.24	-57.33	109.57	39.65	32.24	11	30.65	100	20	P	V
		5917.6	52.16	-21.5	73.66	39.26	32.44	11.15	30.69	100	20	P	V
		5944.8	52.37	-15.83	68.2	39.38	32.49	11.21	30.71	100	20	P	V
													V
													V



WIFI Ant. 4+3	Note	Frequency ( MHz )	Level ( dBμV/m )	Over Limit ( dB )	Limit Line ( dBμV/m )	Read Level ( dBμV )	Antenna Factor ( dB/m )	Path Loss ( dB )	Preamp Factor ( dB )	Ant Pos ( cm )	Table Pos ( deg )	Peak Avg. ( P/A )	Pol. ( H/V )	
802.11an HT20 CH 165 5825MHz	*	5825	110.24	-	-	97.76	32.2	10.91	30.63	100	55	P	H	
	*	5825	101.97	-	-	89.49	32.2	10.91	30.63	100	55	A	H	
		5850.2	58.79	-62.95	121.74	46.26	32.2	10.98	30.65	100	55	P	H	
		5857.2	55.6	-54.58	110.18	43.03	32.23	10.99	30.65	100	55	P	H	
		5879.2	53.84	-48.24	102.08	41.14	32.32	11.05	30.67	100	55	P	H	
		5927	51.8	-16.4	68.2	38.87	32.45	11.17	30.69	100	55	P	H	
														H
														H
	*	5825	112.97	-	-	100.49	32.2	10.91	30.63	100	19	19	P	V
	*	5825	104.61	-	-	92.13	32.2	10.91	30.63	100	19	19	A	V
		5850.2	65.65	-56.09	121.74	53.12	32.2	10.98	30.65	100	19	19	P	V
		5855	61.01	-49.79	110.8	48.45	32.22	10.99	30.65	100	19	19	P	V
		5904	53.12	-30.58	83.7	40.28	32.41	11.11	30.68	100	19	19	P	V
		5926.6	52.37	-15.83	68.2	39.44	32.45	11.17	30.69	100	19	19	P	V
														V
													V	
<b>Remark</b>	1. No other spurious found. 2. All results are PASS against Peak and Average limit line.													



Band 4 5725~5850MHz

WIFI 802.11an HT20 (Harmonic @ 3m)

WIFI Ant. 4+3	Note	Frequency ( MHz )	Level ( dBµV/m )	Over Limit ( dB )	Limit Line ( dBµV/m )	Read Level ( dBµV )	Antenna Factor ( dB/m )	Path Loss ( dB )	Preamp Factor ( dB )	Ant Pos ( cm )	Table Pos ( deg )	Peak Avg. ( P/A )	Pol. ( H/V )
802.11an HT20 CH 149 5745MHz		11490	48.69	-25.31	74	54.26	40.48	14.85	60.9	100	0	P	H
		17235	52.07	-16.13	68.2	51.28	40.94	18.67	58.82	100	0	P	H
													H
													H
		11490	49.2	-24.8	74	54.77	40.48	14.85	60.9	100	0	P	V
		17235	51.46	-16.74	68.2	50.67	40.94	18.67	58.82	100	0	P	V
													V
802.11an HT20 CH 157 5785MHz		11570	49.74	-24.26	74	55.52	40.29	14.91	60.98	100	0	P	H
		17355	52.1	-16.1	68.2	50.23	41.75	18.79	58.67	100	0	P	H
													H
													H
		11570	49.65	-24.35	74	55.43	40.29	14.91	60.98	100	0	P	V
		17355	52.76	-15.44	68.2	50.89	41.75	18.79	58.67	100	0	P	V
													V
802.11an HT20 CH 165 5825MHz		11650	49.4	-24.6	74	55.67	39.85	14.96	61.08	100	0	P	H
		17475	53.19	-15.01	68.2	50.36	42.5	18.86	58.53	100	0	P	H
													H
													H
		11650	49.83	-24.17	74	56.1	39.85	14.96	61.08	100	0	P	V
		17475	53.13	-15.07	68.2	50.3	42.5	18.86	58.53	100	0	P	V
													V
Remark	1. No other spurious found.												
	2. All results are PASS against Peak and Average limit line.												



**Band 4 5725~5850MHz**  
**WIFI 802.11an HT40 (Band Edge @ 3m)**

WIFI Ant. 4+3	Note	Frequency ( MHz )	Level ( dBμV/m )	Over Limit ( dB )	Limit Line ( dBμV/m )	Read Level ( dBμV )	Antenna Factor ( dB/m )	Path Loss ( dB )	Preamp Factor ( dB )	Ant Pos ( cm )	Table Pos ( deg )	Peak Avg. ( P/A )	Pol. ( H/V )
		5618.4	52.92	-15.28	68.2	40.67	31.86	10.89	30.5	100	16	P	H
		5699.4	60.63	-44.13	104.76	48.31	32	10.87	30.55	100	16	P	H
		5718.6	74.13	-36.28	110.41	61.83	32	10.87	30.57	100	16	P	H
		5724.6	75.95	-45.34	121.29	63.65	32	10.87	30.57	100	16	P	H
	*	5755	108.77	-	-	96.48	32.02	10.86	30.59	100	16	P	H
	*	5755	100.98	-	-	88.69	32.02	10.86	30.59	100	16	A	H
		5854.2	51.28	-61.34	112.62	38.72	32.22	10.99	30.65	100	16	P	H
		5867.8	52.57	-54.64	107.21	39.94	32.27	11.02	30.66	100	16	P	H
		5882.8	52.55	-46.86	99.41	39.83	32.33	11.06	30.67	100	16	P	H
		5925.4	52.26	-15.94	68.2	39.33	32.45	11.17	30.69	100	16	P	H
<b>802.11an</b>													H
<b>HT40</b>													H
<b>CH 151</b>		5633.2	51.94	-16.26	68.2	39.73	31.83	10.89	30.51	100	356	P	V
<b>5755MHz</b>		5700	61.38	-43.82	105.2	49.06	32	10.87	30.55	100	356	P	V
		5719	75.78	-34.74	110.52	63.48	32	10.87	30.57	100	356	P	V
		5724.4	79.14	-41.69	120.83	66.84	32	10.87	30.57	100	356	P	V
	*	5755	111.07	-	-	98.78	32.02	10.86	30.59	100	356	P	V
	*	5755	102.78	-	-	90.49	32.02	10.86	30.59	100	356	A	V
		5853.8	53.62	-59.92	113.54	41.06	32.22	10.99	30.65	100	356	P	V
		5865.8	52.47	-55.3	107.77	39.85	32.26	11.02	30.66	100	356	P	V
		5909.8	52.75	-26.67	79.42	39.88	32.42	11.13	30.68	100	356	P	V
		5928.8	52.64	-15.56	68.2	39.71	32.46	11.17	30.7	100	356	P	V
													V
													V



WIFI Ant. 4+3	Note	Frequency ( MHz )	Level ( dBμV/m )	Over Limit ( dB )	Limit Line ( dBμV/m )	Read Level ( dBμV )	Antenna Factor ( dB/m )	Path Loss ( dB )	Preamp Factor ( dB )	Ant Pos ( cm )	Table Pos ( deg )	Peak Avg. ( P/A )	Pol. ( H/V )
		5632	51.71	-16.49	68.2	39.49	31.84	10.89	30.51	100	55	P	H
		5689.8	51.86	-45.82	97.68	39.57	31.96	10.88	30.55	100	55	P	H
		5720	55.65	-55.15	110.8	43.35	32	10.87	30.57	100	55	P	H
		5720.6	56	-56.17	112.17	43.7	32	10.87	30.57	100	55	P	H
	*	5795	107.69	-	-	95.27	32.18	10.85	30.61	100	55	P	H
	*	5795	100.21	-	-	87.79	32.18	10.85	30.61	100	55	A	H
		5854.8	58.19	-53.07	111.26	45.63	32.22	10.99	30.65	100	55	P	H
		5855	56.91	-53.89	110.8	44.35	32.22	10.99	30.65	100	55	P	H
		5882.2	52.7	-47.15	99.85	39.98	32.33	11.06	30.67	100	55	P	H
		5942.6	52.56	-15.64	68.2	39.56	32.49	11.21	30.7	100	55	P	H
802.11an													H
HT40													H
CH 159		5643.4	51.63	-16.57	68.2	39.45	31.81	10.89	30.52	100	17	P	V
5795MHz		5695.8	52.2	-49.9	102.1	39.9	31.98	10.87	30.55	100	17	P	V
		5719	58.34	-52.18	110.52	46.04	32	10.87	30.57	100	17	P	V
		5724.2	58.55	-61.83	120.38	46.25	32	10.87	30.57	100	17	P	V
	*	5795	110.49	-	-	98.07	32.18	10.85	30.61	100	17	P	V
	*	5795	102.63	-	-	90.21	32.18	10.85	30.61	100	17	A	V
		5852.4	60.3	-56.43	116.73	47.76	32.21	10.98	30.65	100	17	P	V
		5855.2	58.51	-52.23	110.74	45.95	32.22	10.99	30.65	100	17	P	V
		5875	55.82	-49.38	105.2	43.14	32.3	11.04	30.66	100	17	P	V
		5934.8	52.42	-15.78	68.2	39.46	32.47	11.19	30.7	100	17	P	V
													V
													V
Remark	1. No other spurious found. 2. All results are PASS against Peak and Average limit line.												



**Band 4 5725~5850MHz**

**WIFI 802.11an HT40 (Harmonic @ 3m)**

WIFI Ant. 4+3	Note	Frequency ( MHz )	Level ( dBμV/m )	Over Limit ( dB )	Limit Line ( dBμV/m )	Read Level ( dBμV )	Antenna Factor ( dB/m )	Path Loss ( dB )	Preamp Factor ( dB )	Ant Pos ( cm )	Table Pos ( deg )	Peak Avg. ( P/A )	Pol. ( H/V )	
802.11an HT40 CH 151 5755MHz		11510	49.31	-24.69	74	54.89	40.47	14.86	60.91	100	0	P	H	
		17265	50.68	-17.52	68.2	49.7	41.06	18.7	58.78	100	0	P	H	
													H	
													H	
			11510	48.4	-25.6	74	53.98	40.47	14.86	60.91	100	0	P	V
			17265	49.88	-18.32	68.2	48.9	41.06	18.7	58.78	100	0	P	V
														V
802.11an HT40 CH 159 5795MHz		11590	49.29	-24.71	74	55.15	40.23	14.92	61.01	100	0	P	H	
		17385	52.72	-15.48	68.2	50.51	42.05	18.8	58.64	100	0	P	H	
													H	
													H	
			11590	49.66	-24.34	74	55.52	40.23	14.92	61.01	100	0	P	V
			17385	51.75	-16.45	68.2	49.54	42.05	18.8	58.64	100	0	P	V
														V
Remark	1. No other spurious found.													
	2. All results are PASS against Peak and Average limit line.													



**Band 4 5725~5850MHz**  
**WIFI 802.11ac VHT80 (Band Edge @ 3m)**

WIFI Ant. 4+3	Note	Frequency ( MHz )	Level ( dBμV/m )	Over Limit ( dB )	Limit Line ( dBμV/m )	Read Level ( dBμV )	Antenna Factor ( dB/m )	Path Loss ( dB )	Preamp Factor ( dB )	Ant Pos ( cm )	Table Pos ( deg )	Peak Avg. ( P/A )	Pol. ( H/V )
		5646.2	53.83	-14.37	68.2	41.65	31.81	10.89	30.52	100	17	P	H
		5699.8	65.98	-39.07	105.05	53.66	32	10.87	30.55	100	17	P	H
		5717.4	69.69	-40.38	110.07	57.38	32	10.87	30.56	100	17	P	H
		5723	72.41	-45.23	117.64	60.11	32	10.87	30.57	100	17	P	H
	*	5775	104.6	-	-	92.24	32.1	10.86	30.6	100	17	P	H
	*	5775	96.97	-	-	84.61	32.1	10.86	30.6	100	17	A	H
		5851	62.4	-57.52	119.92	49.87	32.2	10.98	30.65	100	17	P	H
		5866.4	63.44	-44.17	107.61	50.81	32.27	11.02	30.66	100	17	P	H
		5881.8	56.63	-43.52	100.15	43.91	32.33	11.06	30.67	100	17	P	H
		5947	52.26	-15.94	68.2	39.26	32.49	11.22	30.71	100	17	P	H
<b>802.11ac</b>													H
<b>VHT80</b>													H
<b>CH 155</b>		5647.8	56.38	-11.82	68.2	44.21	31.8	10.89	30.52	100	353	P	V
<b>5775MHz</b>		5699.8	70.38	-34.67	105.05	58.06	32	10.87	30.55	100	353	P	V
		5705.2	74.1	-32.56	106.66	61.79	32	10.87	30.56	100	353	P	V
		5725	75.32	-46.88	122.2	63.02	32	10.87	30.57	100	353	P	V
	*	5775	107.39	-	-	95.03	32.1	10.86	30.6	100	353	P	V
	*	5775	99.83	-	-	87.47	32.1	10.86	30.6	100	353	A	V
		5850	69.33	-52.87	122.2	56.8	32.2	10.98	30.65	100	353	P	V
		5862.2	69.44	-39.34	108.78	56.83	32.25	11.01	30.65	100	353	P	V
		5881.6	61.41	-38.89	100.3	48.69	32.33	11.06	30.67	100	353	P	V
		5929.6	52.75	-15.45	68.2	39.81	32.46	11.18	30.7	100	353	P	V
													V
													V
<b>Remark</b>	1. No other spurious found. 2. All results are PASS against Peak and Average limit line.												



**Band 4 5725~5850MHz**

**WIFI 802.11ac VHT80 (Harmonic @ 3m)**

WIFI Ant. 4+3	Note	Frequency ( MHz )	Level ( dBμV/m )	Over Limit ( dB )	Limit Line ( dBμV/m )	Read Level ( dBμV )	Antenna Factor ( dB/m )	Path Loss ( dB )	Preamp Factor ( dB )	Ant Pos ( cm )	Table Pos ( deg )	Peak Avg. (P/A)	Pol. (H/V)	
802.11ac VHT80 CH 155 5775MHz		11550	50.29	-23.71	74	56	40.35	14.9	60.96	100	220	P	H	
		11550	41.45	-12.55	54	47.16	40.35	14.9	60.96	100	220	A	H	
		17325	52.27	-15.93	68.2	50.76	41.45	18.77	58.71	100	0	P	H	
													H	
			11550	51.57	-22.43	74	57.28	40.35	14.9	60.96	100	101	P	V
			11550	41.5	-12.5	54	47.21	40.35	14.9	60.96	100	101	A	V
			17325	51.71	-16.49	68.2	50.2	41.45	18.77	58.71	100	0	P	V
													V	
Remark	1. No other spurious found. 2. All results are PASS against Peak and Average limit line.													





<TXBF Mode>

Band 4 - 5725~5850MHz

WIFI 802.11ac VHT20 (Band Edge @ 3m)

WIFI Ant.	Note	Frequency	Level	Over Limit	Limit Line	Read Level	Antenna Factor	Path Loss	Preamp Factor	Ant Pos	Table Pos	Peak Avg.	Pol.	
4+3		( MHz )	( dBµV/m )	( dB )	( dBµV/m )	( dBµV )	( dB/m )	( dB )	( dB )	( cm )	( deg )	( P/A )	( H/V )	
802.11ac VHT20 CH 149 5745MHz		5619	53.43	-14.77	68.2	41.18	31.86	10.89	30.5	100	4	P	H	
		5674.4	51.94	-34.36	86.3	39.7	31.9	10.88	30.54	100	4	P	H	
		5717	52.24	-57.72	109.96	39.93	32	10.87	30.56	100	4	P	H	
		5723.4	55.54	-63.01	118.55	43.24	32	10.87	30.57	100	4	P	H	
	*	5745	99.63	-	-	87.35	32	10.86	30.58	100	4	P	H	
	*	5745	90.47	-	-	78.19	32	10.86	30.58	100	4	A	H	
														H
														H
			5628.2	52.83	-15.37	68.2	40.61	31.84	10.89	30.51	280	353	P	V
			5657.8	51.86	-22.13	73.99	39.68	31.83	10.88	30.53	280	353	P	V
			5718.4	51.65	-58.7	110.35	39.35	32	10.87	30.57	280	353	P	V
			5724	54.53	-65.39	119.92	42.23	32	10.87	30.57	280	353	P	V
	*		5745	101.42	-	-	89.14	32	10.86	30.58	280	353	P	V
	*		5745	92.75	-	-	80.47	32	10.86	30.58	280	353	A	V
													V	
													V	



WIFI Ant. 4+3	Note	Frequency ( MHz )	Level ( dBμV/m )	Over Limit ( dB )	Limit Line ( dBμV/m )	Read Level ( dBμV )	Antenna Factor ( dB/m )	Path Loss ( dB )	Preamp Factor ( dB )	Ant Pos ( cm )	Table Pos ( deg )	Peak Avg. ( P/A )	Pol. ( H/V )
		5610.4	51.72	-16.48	68.2	39.45	31.88	10.89	30.5	197	55	P	H
		5665.8	51.42	-28.51	79.93	39.21	31.86	10.88	30.53	197	55	P	H
		5711.6	51.73	-56.72	108.45	39.42	32	10.87	30.56	197	55	P	H
		5723.2	51.28	-66.82	118.1	38.98	32	10.87	30.57	197	55	P	H
	*	5785	99.71	-	-	87.33	32.14	10.85	30.61	197	55	P	H
	*	5785	90.08	-	-	77.7	32.14	10.85	30.61	197	55	A	H
		5850.4	50.96	-70.33	121.29	38.43	32.2	10.98	30.65	197	55	P	H
		5874.6	52.25	-53.06	105.31	39.57	32.3	11.04	30.66	197	55	P	H
		5889.2	52.35	-42.31	94.66	39.59	32.36	11.07	30.67	197	55	P	H
		5939.6	52.57	-15.63	68.2	39.59	32.48	11.2	30.7	197	55	P	H
802.11ac													H
VHT20													H
CH 157		5624.8	51.91	-16.29	68.2	39.68	31.85	10.89	30.51	249	340	P	V
5785MHz		5681	51.93	-39.25	91.18	39.67	31.92	10.88	30.54	249	340	P	V
		5711	51.55	-56.73	108.28	39.24	32	10.87	30.56	249	340	P	V
		5721	50.88	-62.2	113.08	38.58	32	10.87	30.57	249	340	P	V
	*	5785	100	-	-	87.62	32.14	10.85	30.61	249	340	P	V
	*	5785	91.99	-	-	79.61	32.14	10.85	30.61	249	340	A	V
		5853.2	51.98	-62.92	114.9	39.44	32.21	10.98	30.65	249	340	P	V
		5866.6	51.53	-56.02	107.55	38.9	32.27	11.02	30.66	249	340	P	V
		5910.6	52.59	-26.23	78.82	39.72	32.42	11.13	30.68	249	340	P	V
		5936.4	52.21	-15.99	68.2	39.25	32.47	11.19	30.7	249	340	P	V
													V
													V



WIFI Ant. 4+3	Note	Frequency ( MHz )	Level ( dBμV/m )	Over Limit ( dB )	Limit Line ( dBμV/m )	Read Level ( dBμV )	Antenna Factor ( dB/m )	Path Loss ( dB )	Preamp Factor ( dB )	Ant Pos ( cm )	Table Pos ( deg )	Peak Avg. ( P/A )	Pol. ( H/V )	
802.11ac VHT20 CH 165 5825MHz	*	5825	97.79	-	-	85.31	32.2	10.91	30.63	226	54	P	H	
	*	5825	89.78	-	-	77.3	32.2	10.91	30.63	226	54	A	H	
		5854.2	50.91	-61.71	112.62	38.35	32.22	10.99	30.65	226	54	P	H	
		5873.4	51.85	-53.8	105.65	39.19	32.29	11.03	30.66	226	54	P	H	
		5878	52.8	-50.17	102.97	40.1	32.31	11.05	30.66	226	54	P	H	
		5935	53.03	-15.17	68.2	40.07	32.47	11.19	30.7	226	54	P	H	
														H
														H
	*	5825	99.36	-	-	86.88	32.2	10.91	30.63	250	324	324	P	V
	*	5825	90.95	-	-	78.47	32.2	10.91	30.63	250	324	324	A	V
		5855	50.94	-59.86	110.8	38.38	32.22	10.99	30.65	250	324	324	P	V
		5870.8	51.73	-54.64	106.37	39.08	32.28	11.03	30.66	250	324	324	P	V
		5882.2	53.44	-46.41	99.85	40.72	32.33	11.06	30.67	250	324	324	P	V
		5948.8	52.76	-15.44	68.2	39.75	32.5	11.22	30.71	250	324	324	P	V
														V
														V
<b>Remark</b>	1. No other spurious found. 2. All results are PASS against Peak and Average limit line.													



**Band 4 5725~5850MHz**  
**WIFI 802.11ac VHT20 (Harmonic @ 3m)**

WIFI Ant. 4+3	Note	Frequency ( MHz )	Level ( dBµV/m )	Over Limit ( dB )	Limit Line ( dBµV/m )	Read Level ( dBµV )	Antenna Factor ( dB/m )	Path Loss ( dB )	Preamp Factor ( dB )	Ant Pos ( cm )	Table Pos ( deg )	Peak Avg. ( P/A )	Pol. ( H/V )	
802.11ac VHT20 CH 149 5745MHz		11490	49.64	-24.36	74	55.21	40.48	14.85	60.9	100	0	P	H	
		17235	50.71	-17.49	68.2	49.92	40.94	18.67	58.82	100	0	P	H	
													H	
													H	
			11490	49.96	-24.04	74	55.53	40.48	14.85	60.9	100	0	P	V
			17235	51.01	-17.19	68.2	50.22	40.94	18.67	58.82	100	0	P	V
														V
802.11ac VHT20 CH 157 5785MHz		11570	49.88	-24.12	74	55.66	40.29	14.91	60.98	100	0	P	H	
		17355	52.89	-15.31	68.2	51.02	41.75	18.79	58.67	100	0	P	H	
													H	
													H	
			11570	49.98	-24.02	74	55.76	40.29	14.91	60.98	100	0	P	V
			17355	52.6	-15.6	68.2	50.73	41.75	18.79	58.67	100	0	P	V
														V
802.11ac VHT20 CH 165 5825MHz		11650	49.37	-24.63	74	55.64	39.85	14.96	61.08	100	0	P	H	
		17475	52.98	-15.22	68.2	50.15	42.5	18.86	58.53	100	0	P	H	
													H	
													H	
			11650	49.5	-24.5	74	55.77	39.85	14.96	61.08	100	0	P	V
			17475	53.34	-14.86	68.2	50.51	42.5	18.86	58.53	100	0	P	V
														V
Remark	1. No other spurious found.													
	2. All results are PASS against Peak and Average limit line.													



**Band 4 5725~5850MHz**  
**WIFI 802.11ac VHT40 (Band Edge @ 3m)**

WIFI Ant. 4+3	Note	Frequency ( MHz )	Level ( dBμV/m )	Over Limit ( dB )	Limit Line ( dBμV/m )	Read Level ( dBμV )	Antenna Factor ( dB/m )	Path Loss ( dB )	Preamp Factor ( dB )	Ant Pos ( cm )	Table Pos ( deg )	Peak Avg. ( P/A )	Pol. ( H/V )
		5634.2	52.28	-15.92	68.2	40.07	31.83	10.89	30.51	207	8	P	H
		5677.6	51.21	-37.45	88.66	38.96	31.91	10.88	30.54	207	8	P	H
		5709.6	51.75	-56.14	107.89	39.44	32	10.87	30.56	207	8	P	H
		5721.2	52.87	-60.67	113.54	40.57	32	10.87	30.57	207	8	P	H
	*	5755	96.37	-	-	84.08	32.02	10.86	30.59	207	8	P	H
	*	5755	90.64	-	-	78.35	32.02	10.86	30.59	207	8	A	H
		5854.4	51.03	-61.14	112.17	38.47	32.22	10.99	30.65	207	8	P	H
		5875	51.66	-53.54	105.2	38.98	32.3	11.04	30.66	207	8	P	H
		5897.4	52.88	-35.71	88.59	40.08	32.39	11.09	30.68	207	8	P	H
		5944.6	52.71	-15.49	68.2	39.72	32.49	11.21	30.71	207	8	P	H
<b>802.11ac</b>													H
<b>VHT40</b>													H
<b>CH 151</b>		5625.4	51.67	-16.53	68.2	39.44	31.85	10.89	30.51	254	340	P	V
<b>5755MHz</b>		5666.2	51.61	-28.61	80.22	39.4	31.86	10.88	30.53	254	340	P	V
		5715.2	51.98	-57.48	109.46	39.67	32	10.87	30.56	254	340	P	V
		5724.4	51.84	-68.99	120.83	39.54	32	10.87	30.57	254	340	P	V
	*	5755	98.39	-	-	86.1	32.02	10.86	30.59	254	340	P	V
	*	5755	91.2	-	-	78.91	32.02	10.86	30.59	254	340	A	V
		5854.8	51.65	-59.61	111.26	39.09	32.22	10.99	30.65	254	340	P	V
		5875	51.73	-53.47	105.2	39.05	32.3	11.04	30.66	254	340	P	V
		5923	52.24	-17.43	69.67	39.32	32.45	11.16	30.69	254	340	P	V
		5938.4	52.38	-15.82	68.2	39.4	32.48	11.2	30.7	254	340	P	V
													V
													V



WIFI Ant. 4+3	Note	Frequency ( MHz )	Level ( dBμV/m )	Over Limit ( dB )	Limit Line ( dBμV/m )	Read Level ( dBμV )	Antenna Factor ( dB/m )	Path Loss ( dB )	Preamp Factor ( dB )	Ant Pos ( cm )	Table Pos ( deg )	Peak Avg. (P/A)	Pol. (H/V)
		5607.6	51.77	-16.43	68.2	39.49	31.88	10.9	30.5	100	4	P	H
		5661.2	51.76	-24.76	76.52	39.57	31.84	10.88	30.53	100	4	P	H
		5720	51.82	-58.98	110.8	39.52	32	10.87	30.57	100	4	P	H
		5720	51.82	-58.98	110.8	39.52	32	10.87	30.57	100	4	P	H
	*	5795	95.85	-	-	83.43	32.18	10.85	30.61	100	4	P	H
	*	5795	512.42	-	-	500	32.18	10.85	30.61	100	4	A	H
		5853.8	50.47	-63.07	113.54	37.91	32.22	10.99	30.65	100	4	P	H
		5868.4	51.94	-55.11	107.05	39.31	32.27	11.02	30.66	100	4	P	H
		5888.2	52.22	-43.18	95.4	39.47	32.35	11.07	30.67	100	4	P	H
		5934.2	52.37	-15.83	68.2	39.41	32.47	11.19	30.7	100	4	P	H
802.11ac													H
VHT40													H
CH 159		5648.2	52.43	-15.77	68.2	40.26	31.8	10.89	30.52	251	348	P	V
5795MHz		5663.6	52.46	-25.84	78.3	40.26	31.85	10.88	30.53	251	348	P	V
		5701.2	53.24	-52.3	105.54	40.92	32	10.87	30.55	251	348	P	V
		5723.6	53.62	-65.39	119.01	41.32	32	10.87	30.57	251	348	P	V
	*	5795	97.82	-	-	85.4	32.18	10.85	30.61	251	348	P	V
	*	5795	90.81	-	-	78.39	32.18	10.85	30.61	251	348	A	V
		5852.6	52.3	-63.97	116.27	39.76	32.21	10.98	30.65	251	348	P	V
		5870.2	52.59	-53.95	106.54	39.94	32.28	11.03	30.66	251	348	P	V
		5914.8	53.12	-22.6	75.72	40.24	32.43	11.14	30.69	251	348	P	V
		5928.6	53	-15.2	68.2	40.07	32.46	11.17	30.7	251	348	P	V
													V
													V
Remark	1. No other spurious found. 2. All results are PASS against Peak and Average limit line.												



**Band 4 5725~5850MHz  
WIFI 802.11ac VHT40 (Harmonic @ 3m)**

WIFI Ant. 4+3	Note	Frequency ( MHz )	Level ( dBμV/m )	Over Limit ( dB )	Limit Line ( dBμV/m )	Read Level ( dBμV )	Antenna Factor ( dB/m )	Path Loss ( dB )	Preamp Factor ( dB )	Ant Pos ( cm )	Table Pos ( deg )	Peak Avg. ( P/A )	Pol. ( H/V )	
802.11ac VHT40 CH 151 5755MHz		11510	49.89	-24.11	74	55.47	40.47	14.86	60.91	100	0	P	H	
		17265	51.21	-16.99	68.2	50.23	41.06	18.7	58.78	100	0	P	H	
													H	
													H	
			11510	49.83	-24.17	74	55.41	40.47	14.86	60.91	100	0	P	V
			17265	50.9	-17.3	68.2	49.92	41.06	18.7	58.78	100	0	P	V
														V
802.11ac VHT40 CH 159 5795MHz		11590	50.66	-23.34	74	56.52	40.23	14.92	61.01	100	0	P	H	
		17385	53	-15.2	68.2	50.79	42.05	18.8	58.64	100	0	P	H	
													H	
													H	
			11590	50.13	-23.87	74	55.99	40.23	14.92	61.01	100	0	P	V
			17385	53.16	-15.04	68.2	50.95	42.05	18.8	58.64	100	0	P	V
														V
Remark	1. No other spurious found.													
	2. All results are PASS against Peak and Average limit line.													



**Band 4 5725~5850MHz  
WIFI 802.11ac VHT80 (Band Edge @ 3m)**

WIFI Ant. 4+3	Note	Frequency ( MHz )	Level ( dBμV/m )	Over Limit ( dB )	Limit Line ( dBμV/m )	Read Level ( dBμV )	Antenna Factor ( dB/m )	Path Loss ( dB )	Preamp Factor ( dB )	Ant Pos ( cm )	Table Pos ( deg )	Peak Avg. ( P/A )	Pol. ( H/V )	
		5614.8	52.26	-15.94	68.2	40	31.87	10.89	30.5	100	7	P	H	
		5690.4	52.35	-45.77	98.12	40.06	31.96	10.88	30.55	100	7	P	H	
		5713.4	51.75	-57.2	108.95	39.44	32	10.87	30.56	100	7	P	H	
		5721.8	51.57	-63.33	114.9	39.27	32	10.87	30.57	100	7	P	H	
	*	5775	96.63	-	-	84.27	32.1	10.86	30.6	100	7	P	H	
	*	5775	90.78	-	-	78.42	32.1	10.86	30.6	100	7	A	H	
		5851.4	51.71	-67.3	119.01	39.17	32.21	10.98	30.65	100	7	P	H	
		5856	50.76	-59.76	110.52	38.2	32.22	10.99	30.65	100	7	P	H	
		5913.4	52.44	-24.32	76.76	39.56	32.43	11.14	30.69	100	7	P	H	
		5935.8	53.05	-15.15	68.2	40.09	32.47	11.19	30.7	100	7	P	H	
<b>802.11ac VHT80 CH 155 5775MHz</b>													H	
													H	
			5623.6	52.75	-15.45	68.2	40.52	31.85	10.89	30.51	276	354	P	V
			5673.4	51.78	-33.78	85.56	39.55	31.89	10.88	30.54	276	354	P	V
			5718	52.74	-57.5	110.24	40.44	32	10.87	30.57	276	354	P	V
			5722	51.92	-63.44	115.36	39.62	32	10.87	30.57	276	354	P	V
		*	5775	98.65	-	-	86.29	32.1	10.86	30.6	276	354	P	V
		*	5775	91.85	-	-	79.49	32.1	10.86	30.6	276	354	A	V
			5854.2	51.87	-60.75	112.62	39.31	32.22	10.99	30.65	276	354	P	V
			5855.6	52.36	-58.27	110.63	39.8	32.22	10.99	30.65	276	354	P	V
			5922.8	52.46	-17.36	69.82	39.54	32.45	11.16	30.69	276	354	P	V
			5936.8	53.57	-14.63	68.2	40.61	32.47	11.19	30.7	276	354	P	V
														V
														V
	<b>Remark</b>	1. No other spurious found. 2. All results are PASS against Peak and Average limit line.												



**Band 4 5725~5850MHz**

**WIFI 802.11ac VHT80 (Harmonic @ 3m)**

WIFI Ant. 4+3	Note	Frequency ( MHz )	Level ( dBμV/m )	Over Limit ( dB )	Limit Line ( dBμV/m )	Read Level ( dBμV )	Antenna Factor ( dB/m )	Path Loss ( dB )	Preamp Factor ( dB )	Ant Pos ( cm )	Table Pos ( deg )	Peak Avg. (P/A)	Pol. (H/V)	
802.11ac VHT80 CH 155 5775MHz		11550	49.97	-24.03	74	55.68	40.35	14.9	60.96	100	0	P	H	
		17325	52.44	-15.76	68.2	50.93	41.45	18.77	58.71	100	0	P	H	
													H	
													H	
			11550	49.94	-24.06	74	55.65	40.35	14.9	60.96	100	0	P	V
			17325	51.92	-16.28	68.2	50.41	41.45	18.77	58.71	100	0	P	V
														V
Remark	1. No other spurious found. 2. All results are PASS against Peak and Average limit line.													





**Note symbol**

*	<b>Fundamental Frequency</b> which can be ignored. However, the level of any unwanted emissions shall not exceed the level of the fundamental frequency.
!	Test result is <b>over limit</b> line.
P/A	<b>Peak</b> or <b>Average</b>
H/V	<b>Horizontal</b> or <b>Vertical</b>



A calculation example for radiated spurious emission is shown as below:

WIFI	Note	Frequency	Level	Over	Limit	Read	Antenna	Path	Preamp	Ant	Table	Peak	Pol.
Ant.				Limit	Line	Level	Factor	Loss	Factor	Pos	Pos	Avg.	
1+2		( MHz )	( dBμV/m )	( dB )	( dBμV/m )	( dBμV )	( dB/m )	( dB )	( dB )	( cm )	( deg )	( P/A )	( H/V )
802.11b		2390	55.45	-18.55	74	54.51	32.22	4.58	35.86	103	308	P	H
CH 01		2390	43.54	-10.46	54	42.6	32.22	4.58	35.86	103	308	A	H
2412MHz													

1. Path Loss(dB) = Cable loss(dB) + Filter loss(dB) + Attenuator loss(dB)
2. Level(dBμV/m) = Antenna Factor(dB/m) + Path Loss(dB) + Read Level(dBμV) - Preamp Factor(dB)
3. Over Limit(dB) = Level(dBμV/m) – Limit Line(dBμV/m)

**For Peak Limit @ 2390MHz:**

1. Level(dBμV/m)  
= Antenna Factor(dB/m) + Path Loss(dB) + Read Level(dBμV) - Preamp Factor(dB)  
= 32.22(dB/m) + 4.58(dB) + 54.51(dBμV) – 35.86 (dB)  
= 55.45 (dBμV/m)
2. Over Limit(dB)  
= Level(dBμV/m) – Limit Line(dBμV/m)  
= 55.45(dBμV/m) – 74(dBμV/m)  
= -18.55(dB)

**For Average Limit @ 2390MHz:**

1. Level(dBμV/m)  
= Antenna Factor(dB/m) + Path Loss(dB) + Read Level(dBμV) - Preamp Factor(dB)  
= 32.22(dB/m) + 4.58(dB) + 42.6(dBμV) – 35.86 (dB)  
= 43.54 (dBμV/m)
2. Over Limit(dB) = Level(dBμV/m) – Limit Line(dBμV/m)  
= 43.54(dBμV/m) – 54(dBμV/m)  
= -10.46(dB)

**Both peak and average measured complies with the limit line, so test result is “PASS”.**



## Appendix D. Radiated Spurious Emission Plots

Test Engineer :	Leo Lee, Mancy Chou and Bigshow Wang	Temperature :	21.4~22.9°C
		Relative Humidity :	52~61%

### Note symbol

-L	Low channel location
-R	High channel location



<CDD Mode>

**Band 4 - 5725~5850MHz**  
**WIFI 802.11a (Band Edge @ 3m)**

WIFI	Band 4 5725~5850MHz Band Edge @ 3m	
ANT	802.11a CH149 5745MHz	
4+3	Horizontal	Fundamental
Peak	<p>Site : 03CH15-HY            Condition : PEAK_BE(84)_16-24 3m 91200_15_1620 HORIZONTAL            Detector : Peak            Project : 051232</p>	<p>Site : 03CH15-HY            Condition : PEAK(LINII) 3m 91200_15_1620 HORIZONTAL            Detector : Peak            Project : 051232</p>

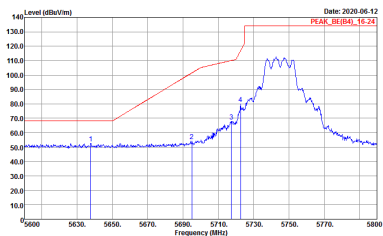
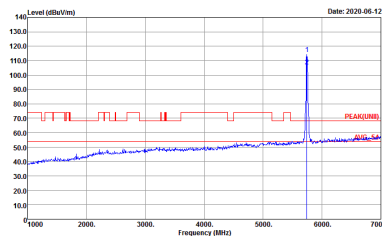

WIFI	Band 4 5725~5850MHz Band Edge @ 3m	
ANT	802.11a CH149 5745MHz	
4+3	Vertical	Fundamental
Peak	 <p>Date: 2020-06-12 PEAK_BE(4)_15_20</p> <p>Site : 03CH15-HY Condition : PEAK_BE(4)_16-24 3m 91200_15_1620 VERTICAL RBW:1000.000KHz VBW:3000.000KHz SWT:Auto Detector : Peak Project : 051232</p>	 <p>Date: 2020-06-12 PEAK(UN)</p> <p>Site : 03CH15-HY Condition : PEAK(UN) 3m 91200_15_1620 VERTICAL RBW:1000.000KHz VBW:3000.000KHz SWT:Auto Detector : Peak Project : 051232</p>



WIFI	Band 4 5725~5850MHz Band Edge @ 3m	
ANT	802.11a CH157 5785MHz	
4+3	Horizontal	Fundamental
<p><b>Peak</b></p>	<p>Site : 03CH15-HY            Condition : PEAK_BE(B4)_16-24 3m 91200_15_1620 HORIZONTAL            RBW:1000.000KHz VBW:3000.000KHz SWT:Auto            Detector : Peak            Project : 051232</p>	<p>Site : 03CH15-HY            Condition : PEAK(UNII) 3m 91200_15_1620 HORIZONTAL            RBW:1000.000KHz VBW:3000.000KHz SWT:Auto            Detector : Peak            Project : 051232</p>
<p><b>Peak</b></p>	<p>Site : 03CH15-HY            Condition : PEAK_BE(B4)_16-24 3m 91200_15_1620 HORIZONTAL            RBW:1000.000KHz VBW:3000.000KHz SWT:Auto            Detector : Peak            Project : 051232</p>	<p><b>Left blank</b></p>



WIFI	Band 4 5725~5850MHz Band Edge @ 3m	
ANT	802.11a CH157 5785MHz	
4+3	Vertical	Fundamental
Peak	<p>Site : 03CH15-HY            Condition : PEAK_BE(84)_16-24 3m 91200_15_1620 VERTICAL            RBW:1000.000KHz VBW:3000.000KHz SWT:Auto            Detector : Peak            Project : 051232</p>	<p>Site : 03CH15-HY            Condition : PEAK(UNII) 3m 91200_15_1620 VERTICAL            RBW:1000.000KHz VBW:3000.000KHz SWT:Auto            Detector : Peak            Project : 051232</p>
Peak	<p>Site : 03CH15-HY            Condition : PEAK_BE(84)_16-24 3m 91200_15_1620 VERTICAL            RBW:1000.000KHz VBW:3000.000KHz SWT:Auto            Detector : Peak            Project : 051232</p>	Left blank

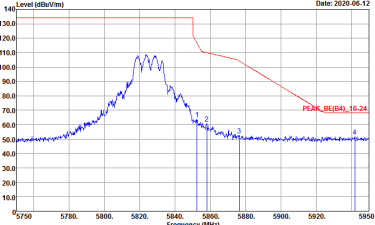
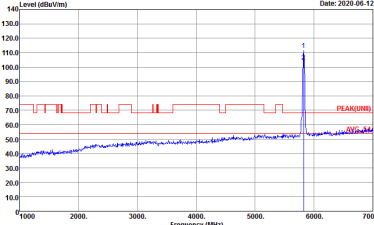

WIFI	Band 4 5725~5850MHz Band Edge @ 3m	
ANT	802.11a CH165 5825MHz	
4+3	Horizontal	Fundamental
Peak	 <p>Date: 2020-06-12</p> <p>Site : 03CH15-HY          Condition : PEAK_BE(B4)_16-24 3m 91200_15_1620 HORIZONTAL          RBW:1000.000KHz VBW:3000.000KHz SWT:Auto          Detector : Peak          Project : 051232</p>	 <p>Date: 2020-06-12</p> <p>Site : 03CH15-HY          Condition : PEAK(UNII) 3m 91200_15_1620 HORIZONTAL          RBW:1000.000KHz VBW:3000.000KHz SWT:Auto          Detector : Peak          Project : 051232</p>

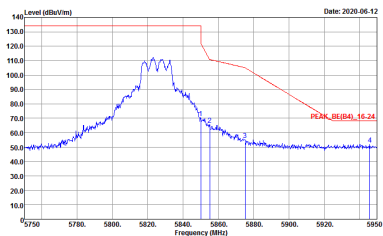
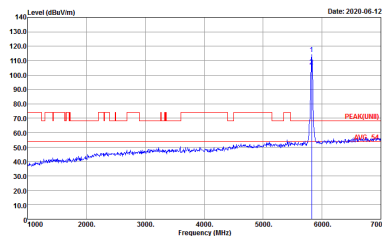

WIFI	Band 4 5725~5850MHz Band Edge @ 3m	
ANT	802.11a CH165 5825MHz	
4+3	Vertical	Fundamental
Peak	 <p>Date: 2020-06-12</p> <p>Site : 03CH15-HY          Condition : PEAK_8E(84)_16-24 3m 91200_15_1620 VERTICAL          RBW:1000.000KHz VBW:3000.000KHz SWT:Auto          Detector : Peak          Project : 051232</p>	 <p>Date: 2020-06-12</p> <p>Site : 03CH15-HY          Condition : PEAK(UNII) 3m 91200_15_1620 VERTICAL          RBW:1000.000KHz VBW:3000.000KHz SWT:Auto          Detector : Peak          Project : 051232</p>



**Band 4 5725~5850MHz  
WIFI 802.11an HT20 (Band Edge @ 3m)**

<b>WIFI</b>	<b>Band 4 5725~5850MHz Band Edge @ 3m</b>	
<b>ANT</b>	<b>802.11an HT20 CH149 5745MHz</b>	
<b>4+3</b>	<b>Horizontal</b>	<b>Fundamental</b>
<b>Peak</b>	<p>Site : 03CH15-HY          Condition : PEAK_BE(B4)_16-24 3m 91200_15_1620 HORIZONTAL          RBW:1000.000kHz VBW:3000.000kHz SWT:Auto          Detector : Peak          Project : 051232</p>	<p>Site : 03CH15-HY          Condition : PEAK(LIN) 3m 91200_15_1620 HORIZONTAL          RBW:1000.000kHz VBW:3000.000kHz SWT:Auto          Detector : Peak          Project : 051232</p>

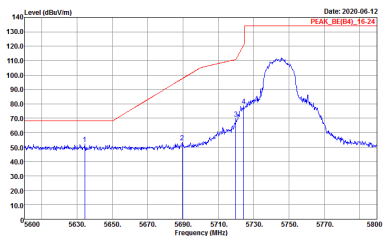
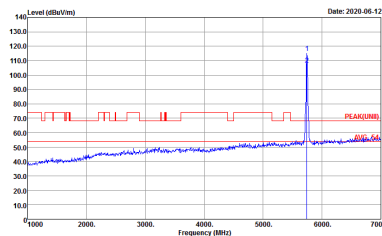

WIFI	Band 4 5725~5850MHz Band Edge @ 3m	
ANT	802.11an HT20 CH149 5745MHz	
4+3	Vertical	Fundamental
<p><b>Peak</b></p> <p><b>Avg.</b></p>	 <p>Site : 03CH15-HY          Condition : PEAK_8E(84)_16-24 3m 91200_15_1620 VERTICAL          RBW:1000.000KHz VBW:3000.000KHz SWT:Auto          Detector : Peak          Project : 051232</p>	 <p>Site : 03CH15-HY          Condition : PEAK(UNI) 3m 91200_15_1620 VERTICAL          RBW:1000.000KHz VBW:3000.000KHz SWT:Auto          Detector : Peak          Project : 051232</p>



WIFI	Band 4 5725~5850MHz Band Edge @ 3m	
ANT	802.11an HT20 CH157 5785MHz	
4+3	Horizontal	Fundamental
<p><b>Peak</b></p>	<p>Date: 2020-06-12 PEAK_BE(84)_16-24</p> <p>Site : 03CH15-HY Condition : PEAK_BE(84)_16-24 3m 91200_15_1620 HORIZONTAL RBW:1000.000KHz VBW:3000.000KHz SWT:Auto Detector : Peak Project : 051232</p>	<p>Date: 2020-06-12 PEAK(UNB)</p> <p>Site : 03CH15-HY Condition : PEAK(UNB) 3m 91200_15_1620 HORIZONTAL RBW:1000.000KHz VBW:3000.000KHz SWT:Auto Detector : Peak Project : 051232</p>
<p><b>Peak</b></p>	<p>Date: 2020-06-12 PEAK_BE(84)_16-24</p> <p>Site : 03CH15-HY Condition : PEAK_BE(84)_16-24 3m 91200_15_1620 HORIZONTAL RBW:1000.000KHz VBW:3000.000KHz SWT:Auto Detector : Peak Project : 051232</p>	<p><b>Left blank</b></p>



WIFI	Band 4 5725~5850MHz Band Edge @ 3m	
ANT	802.11an HT20 CH157 5785MHz	
4+3	Vertical	Fundamental
<p><b>Peak</b></p>	<p>Date: 2020-06-12 PEAK_BE(84)_15-24</p> <p>Site : 03CH15-HY Condition : PEAK_BE(84)_16-24 3m 91200_15_1620 VERTICAL RBW:1000.000KHz VBW:3000.000KHz SWT:Auto Detector : Peak Project : 051232</p>	<p>Date: 2020-06-12 PEAK(UNB) SUS-AR</p> <p>Site : 03CH15-HY Condition : PEAK(UNB) 3m 91200_15_1620 VERTICAL RBW:1000.000KHz VBW:3000.000KHz SWT:Auto Detector : Peak Project : 051232</p>
<p><b>Peak</b></p>	<p>Date: 2020-06-12 PEAK_BE(84)_16-24</p> <p>Site : 03CH15-HY Condition : PEAK_BE(84)_16-24 3m 91200_15_1620 VERTICAL RBW:1000.000KHz VBW:3000.000KHz SWT:Auto Detector : Peak Project : 051232</p>	<p><b>Left blank</b></p>

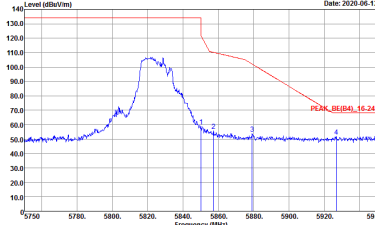
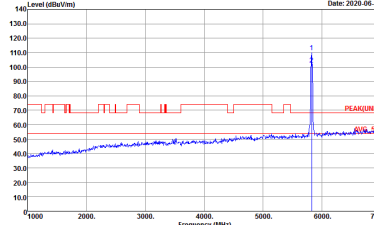

WIFI	Band 4 5725~5850MHz Band Edge @ 3m	
ANT	802.11an HT20 CH165 5825MHz	
4+3	Horizontal	Fundamental
Peak	 <p>Date: 2020-06-12</p> <p>PEAK_BE(B4)_16-24</p> <p>Site : 03CH15-HY          Condition : PEAK_BE(B4)_16-24 3m 91200_15_1620 HORIZONTAL          RBW:1000.000KHz VBW:3000.000KHz SWT:Auto          Detector : Peak          Project : 051232</p>	 <p>Date: 2020-06-12</p> <p>PEAK(FUN)</p> <p>Site : 03CH15-HY          Condition : PEAK(FUN) 3m 91200_15_1620 HORIZONTAL          RBW:1000.000KHz VBW:3000.000KHz SWT:Auto          Detector : Peak          Project : 051232</p>

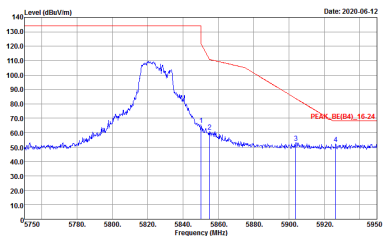
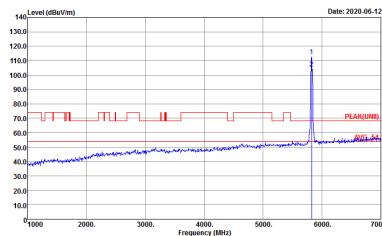

WIFI	Band 4 5725~5850MHz Band Edge @ 3m	
ANT	802.11an HT20 CH165 5825MHz	
4+3	Vertical	Fundamental
<p><b>Peak</b></p> <p><b>Avg.</b></p>	 <p>Site : 03CH15-HY          Condition : PEAK_8E(84)_16-24 3m 91200_15_1620 VERTICAL          RBW:1000.000KHz VBW:3000.000KHz SWT:Auto          Detector : Peak          Project : 051232</p>	 <p>Site : 03CH15-HY          Condition : PEAK(UNI) 3m 91200_15_1620 VERTICAL          RBW:1000.000KHz VBW:3000.000KHz SWT:Auto          Detector : Peak          Project : 051232</p>

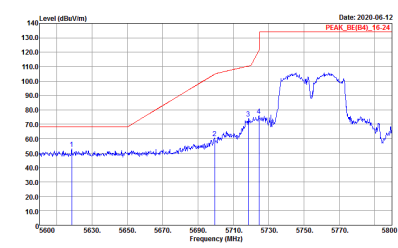
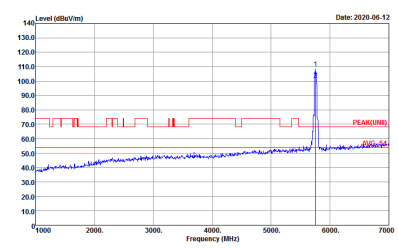
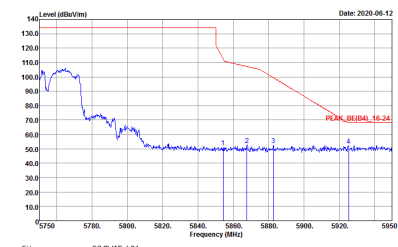

**Band 4 5725~5850MHz**  
**WIFI 802.11an HT40 (Band Edge @ 3m)**

WIFI	Band 4 5725~5850MHz Band Edge @ 3m	
ANT	802.11an HT40 CH151 5755MHz	
4+3	Horizontal	Fundamental
Peak	 <p>Site : 03CH15-HY          Condition : PEAK_BE(B4)_16-24 3m 91200_15_1620 HORIZONTAL          Detector : Peak          Project : 051232</p>	 <p>Site : 03CH15-HY          Condition : PEAK(UNIT) 3m 91200_15_1620 HORIZONTAL          Detector : Peak          Project : 051232</p>
Peak	 <p>Site : 03CH15-HY          Condition : PEAK_BE(B4)_16-24 3m 91200_15_1620 HORIZONTAL          Detector : Peak          Project : 051232</p>	Left blank



WIFI	Band 4 5725~5850MHz Band Edge @ 3m	
ANT	802.11an HT40 CH151 5755MHz	
4+3	Vertical	Fundamental
<p><b>Peak</b></p>	<p>Site : 03CH15-HY            Condition : PEAK_BE(B4)_16-24 3m 91200_15_1620 VERTICAL            Detector : Peak            Project : 051232</p>	<p>Site : 03CH15-HY            Condition : PEAK(UNII) 3m 91200_15_1620 VERTICAL            Detector : Peak            Project : 051232</p>
<p><b>Peak</b></p>	<p>Site : 03CH15-HY            Condition : PEAK_BE(B4)_16-24 3m 91200_15_1620 VERTICAL            Detector : Peak            Project : 051232</p>	<p><b>Left blank</b></p>



WIFI	Band 4 5725~5850MHz Band Edge @ 3m	
ANT	802.11an HT40 CH159 5795MHz	
4+3	Horizontal	Fundamental
<p><b>Peak</b></p>		
<p><b>Peak</b></p>		<p><b>Left blank</b></p>

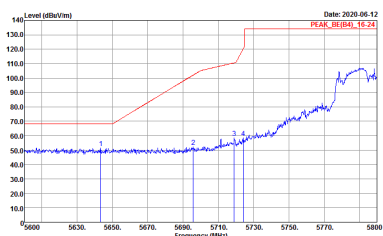
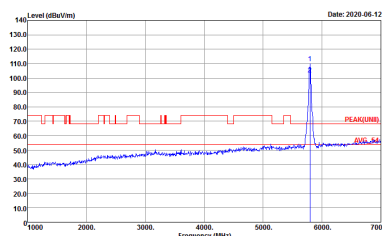
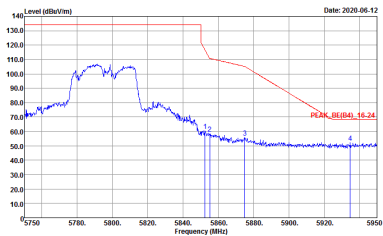

WIFI	Band 4 5725~5850MHz Band Edge @ 3m	
ANT	802.11an HT40 CH159 5795MHz	
4+3	Vertical	Fundamental
<p><b>Peak</b></p>	 <p>Site : 03CH15-HY            Condition : PEAK_BE(84)_16-24 3m 91200_15_1620 VERTICAL            RBW:1000.000KHz VBW:3000.000KHz SWT:Auto            Detector : Peak            Project : 051232</p>	 <p>Site : 03CH15-HY            Condition : PEAK(UNII) 3m 91200_15_1620 VERTICAL            RBW:1000.000KHz VBW:3000.000KHz SWT:Auto            Detector : Peak            Project : 051232</p>
<p><b>Peak</b></p>	 <p>Site : 03CH15-HY            Condition : PEAK_BE(84)_16-24 3m 91200_15_1620 VERTICAL            RBW:1000.000KHz VBW:3000.000KHz SWT:Auto            Detector : Peak            Project : 051232</p>	<p><b>Left blank</b></p>



**Band 4 5725~5850MHz  
WIFI 802.11ac VHT80 (Band Edge @ 3m)**

<b>WIFI</b>	<b>Band 4 5725~5850MHz Band Edge @ 3m</b>	
<b>ANT</b>	<b>802.11ac VHT80 CH155 5775MHz</b>	
<b>4+3</b>	<b>Horizontal</b>	<b>Fundamental</b>
<b>Peak</b>	<p>Site : 03CH15-HY Condition : PEAK_BE(B4)_16-24 3m 91200_15_1620 HORIZONTAL Detector : Peak Project : 051232</p>	<p>Site : 03CH15-HY Condition : PEAK(UNIT) 3m 91200_15_1620 HORIZONTAL Detector : Peak Project : 051232</p>
<b>Peak</b>	<p>Site : 03CH15-HY Condition : PEAK_BE(B4)_16-24 3m 91200_15_1620 HORIZONTAL Detector : Peak Project : 051232</p>	<b>Left blank</b>

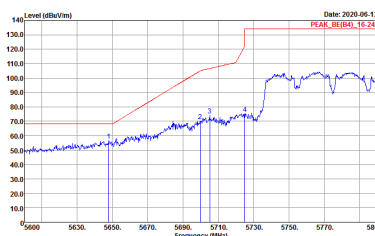
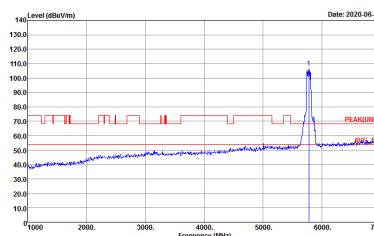
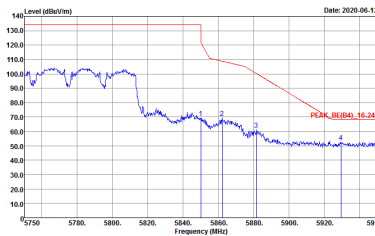

WIFI	Band 4 5725~5850MHz Band Edge @ 3m	
ANT	802.11ac VHT80 CH155 5775MHz	
4+3	Vertical	Fundamental
<p><b>Peak</b></p>	 <p>Date: 2020-06-12 PEAK_BE(84)_15-20</p> <p>Site : 03CH15-HY Condition : PEAK_BE(84)_16-24 3m 91200_15_1620 VERTICAL RBW:1000.000KHz VBW:3000.000KHz SWT:Auto Detector : Peak Project : 051232</p>	 <p>Date: 2020-06-12 PEAK(84)</p> <p>Site : 03CH15-HY Condition : PEAK(UNII) 3m 91200_15_1620 VERTICAL RBW:1000.000KHz VBW:3000.000KHz SWT:Auto Detector : Peak Project : 051232</p>
<p><b>Peak</b></p>	 <p>Date: 2020-06-12 PEAK_BE(84)_16-24</p> <p>Site : 03CH15-HY Condition : PEAK_BE(84)_16-24 3m 91200_15_1620 VERTICAL RBW:1000.000KHz VBW:3000.000KHz SWT:Auto Detector : Peak Project : 051232</p>	<p><b>Left blank</b></p>



**Band 4 - 5725~5850MHz**  
**WIFI 802.11a (Harmonic @ 3m)**

<b>WIFI</b>	<b>Band 4 5725~5850MHz Harmonic @ 3m</b>	
<b>ANT</b>	<b>802.11a CH149 5745MHz</b>	
<b>4+3</b>	<b>Horizontal</b>	<b>Vertical</b>
<b>Peak</b> <b>Avg.</b>	<p>           Site : 03CH15-1FY            Condition : PEAK(UNII) 3m 9120D_15_1620 HORIZONTAL            Detector : Peak            Project : 051232         </p>	<p>           Site : 03CH15-1FY            Condition : PEAK(UNII) 3m 9120D_15_1620 VERTICAL            Detector : Peak            Project : 051232         </p>



<b>WIFI</b>	<b>Band 4 5725~5850MHz Harmonic @ 3m</b>	
<b>ANT</b>	<b>802.11a CH157 5785MHz</b>	
<b>4+3</b>	<b>Horizontal</b>	<b>Vertical</b>
<b>Peak</b> <b>Avg.</b>	<p>Site : 03CH15-HY Condition : PEAK(UNII) 3m 91200_15_1620 HORIZONTAL Detector : Peak Project : 051232</p>	<p>Site : 03CH15-HY Condition : PEAK(UNII) 3m 91200_15_1620 VERTICAL Detector : Peak Project : 051232</p>

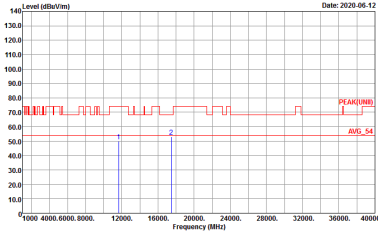
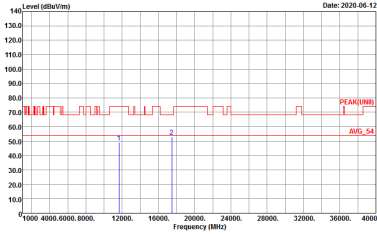

WIFI	Band 4 5725~5850MHz Harmonic @ 3m	
ANT	802.11a CH165 5825MHz	
4+3	Horizontal	Vertical
<p><b>Peak</b></p> <p><b>Avg.</b></p>	 <p>Site : 03CH15-HY          Condition : PEAK(UNII) 3m 91200_15_1620 HORIZONTAL          Detector : Peak          Project : 051232</p>	 <p>Site : 03CH15-HY          Condition : PEAK(UNII) 3m 91200_15_1620 VERTICAL          Detector : Peak          Project : 051232</p>



Band 4 5725~5850MHz  
WIFI 802.11an HT20 (Harmonic @ 3m)

WIFI	Band 4 5725~5850MHz Harmonic @ 3m	
ANT	802.11an HT20 CH149 5745MHz	
4+3	Horizontal	Vertical
Peak Avg.	<p>Site : 03CH15-HY Condition : PEAK(UNI) 3m 91200_15_1620 HORIZONTAL Detector : Peak Project : 051232</p>	<p>Site : 03CH15-HY Condition : PEAK(UNI) 3m 91200_15_1620 VERTICAL Detector : Peak Project : 051232</p>

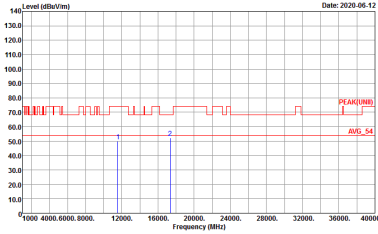
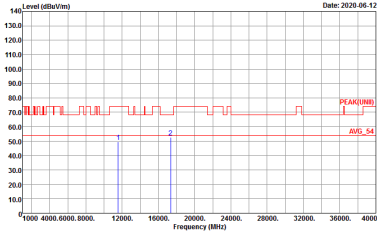

WIFI	Band 4 5725~5850MHz Harmonic @ 3m	
ANT	802.11an HT20 CH157 5785MHz	
4+3	Horizontal	Vertical
<p><b>Peak</b></p> <p><b>Avg.</b></p>	 <p>Site : 03CH15-HY          Condition : PEAK(UNII) 3m 91200_15_1620 HORIZONTAL          Detector : Peak          Project : 051232</p>	 <p>Site : 03CH15-HY          Condition : PEAK(UNII) 3m 91200_15_1620 VERTICAL          Detector : Peak          Project : 051232</p>

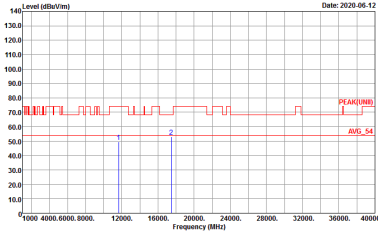
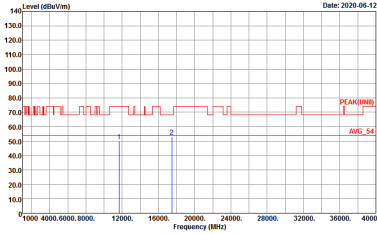

WIFI	Band 4 5725~5850MHz Harmonic @ 3m	
ANT	802.11an HT20 CH165 5825MHz	
4+3	Horizontal	Vertical
<p><b>Peak</b></p> <p><b>Avg.</b></p>	 <p>Site : 03CH15-HY          Condition : PEAK(UNII) 3m 91200_15_1620 HORIZONTAL          Detector : Peak          Project : 051232</p>	 <p>Site : 03CH15-HY          Condition : PEAK(UNII) 3m 91200_15_1620 VERTICAL          Detector : Peak          Project : 051232</p>



**Band 4 5725~5850MHz  
WIFI 802.11an HT40 (Harmonic @ 3m)**

<b>WIFI</b>	<b>Band 4 5725~5850MHz Harmonic @ 3m</b>	
<b>ANT</b>	<b>802.11an HT40 CH151 5755MHz</b>	
<b>4+3</b>	<b>Horizontal</b>	<b>Vertical</b>
<b>Peak Avg.</b>	<p>Site : 03CH15-HY Condition : PEAK(UNI) 3m 91200_15_1620 HORIZONTAL Detector : Peak Project : 051232</p>	<p>Site : 03CH15-HY Condition : PEAK(UNI) 3m 91200_15_1620 VERTICAL Detector : Peak Project : 051232</p>



<b>WIFI</b>	<b>Band 4 5725~5850MHz Harmonic @ 3m</b>	
<b>ANT</b>	<b>802.11an HT40 CH159 5795MHz</b>	
<b>4+3</b>	<b>Horizontal</b>	<b>Vertical</b>
<b>Peak</b> <b>Avg.</b>	<p>Site : 03CH15-HY          Condition : PEAK(UNII) 3m 91200_15_1620 HORIZONTAL          Detector : Peak          Project : 051232</p>	<p>Site : 03CH15-HY          Condition : PEAK(UNII) 3m 91200_15_1620 VERTICAL          Detector : Peak          Project : 051232</p>



Band 4 5725~5850MHz
WIFI 802.11ac VHT80 (Harmonic @ 3m)

Table with 2 columns: Horizontal and Vertical. Rows include WIFI (Band 4 5725~5850MHz Harmonic @ 3m), ANT (802.11ac VHT80 CH155 5775MHz), 4+3, and Peak/Avg. Each graph shows Level (dBuV/m) vs Frequency (MHz) with peak and average markers.



Emission below 1GHz
5GHz WIFI 802.11ac VHT80 (LF)

Table with 4 columns: WIFI (5GHz WIFI), ANT (802.11ac VHT80 LF), 4+3 (Horizontal/Vertical), and QP/Peak. Each column contains a spectral plot and test parameters.



<TXBF Mode>

**Band 4 - 5725~5850MHz**  
**WIFI 802.11ac VHT20 (Band Edge @ 3m)**

<b>WIFI</b>	<b>Band 4 5725~5850MHz Band Edge @ 3m</b>	
<b>ANT</b>	<b>802.11ac VHT20 CH149 5745MHz</b>	
<b>4+3</b>	<b>Horizontal</b>	<b>Fundamental</b>
<b>Peak</b>	<p>           Date: 2020-08-26            PEAK (BELO) 135.0         </p> <p>           Site : 03CH15-HY            Condition : PEAK_BE(B4)_16-24 3m 91200_15_1620 HORIZONTAL            Detector : Peak            Project : 051232         </p>	<p>           Date: 2020-08-26            PEAK(LINL) 135.0         </p> <p>           Site : 03CH15-HY            Condition : PEAK(LINL) 3m 91200_15_1620 HORIZONTAL            Detector : Peak            Project : 051232         </p>



<b>WIFI</b>	<b>Band 4 5725~5850MHz Band Edge @ 3m</b>	
<b>ANT</b>	<b>802.11ac VHT20 CH149 5745MHz</b>	
<b>4+3</b>	<b>Vertical</b>	<b>Fundamental</b>
<b>Peak Avg.</b>	<p>           Date: 2020-08-26  <b>PEAK: BE(84)_16-24</b>            Site : 03CH15-HY            Condition : PEAK_BE(84)_16-24 3m 91200_15_1620 VERTICAL            Detector : Peak            Project : 051232         </p>	<p>           Date: 2020-08-26  <b>PEAK: UNII</b>  <b>Avg: Off</b>            Site : 03CH15-HY            Condition : PEAK(UNII) 3m 91200_15_1620 VERTICAL            Detector : Peak            Project : 051232         </p>

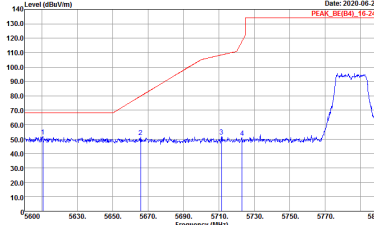
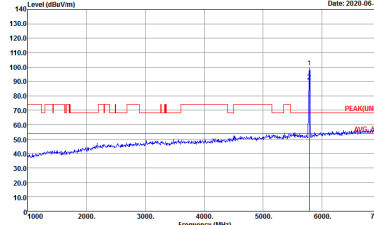
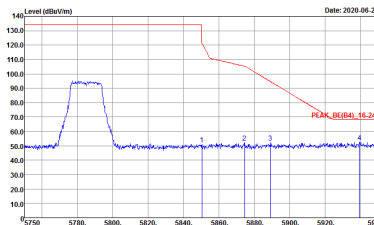

WIFI	Band 4 5725~5850MHz Band Edge @ 3m	
ANT	802.11ac VHT20 CH157 5785MHz	
4+3	Horizontal	Fundamental
<p><b>Peak</b></p>	 <p>Site : 03CH15-HY            Condition : PEAK_BE(B4)_16-24 3m 91200_15_1620 HORIZONTAL            RBW:1000.000KHz VBW:3000.000KHz SWT:Auto            Detector : Peak            Project : 051232</p>	 <p>Site : 03CH15-HY            Condition : PEAK(UNII) 3m 91200_15_1620 HORIZONTAL            RBW:1000.000KHz VBW:3000.000KHz SWT:Auto            Detector : Peak            Project : 051232</p>
<p><b>Peak</b></p>	 <p>Site : 03CH15-HY            Condition : PEAK_BE(B4)_16-24 3m 91200_15_1620 HORIZONTAL            RBW:1000.000KHz VBW:3000.000KHz SWT:Auto            Detector : Peak            Project : 051232</p>	<p><b>Left blank</b></p>



WIFI	Band 4 5725~5850MHz Band Edge @ 3m	
ANT	802.11ac VHT20 CH157 5785MHz	
4+3	Vertical	Fundamental
Peak	<p>Site : 03CH15-1HY          Condition : PEAK_BE(84)_15-24 3m 91200_15_1620 VERTICAL          Detector : Peak          Project : 051232</p>	<p>Site : 03CH15-1HY          Condition : PEAK(UNII) 3m 91200_15_1620 VERTICAL          Detector : Peak          Project : 051232</p>
Peak	<p>Site : 03CH15-1HY          Condition : PEAK_BE(84)_15-24 3m 91200_15_1620 VERTICAL          Detector : Peak          Project : 051232</p>	Left blank



WIFI	Band 4 5725~5850MHz Band Edge @ 3m	
ANT	802.11ac VHT20 CH165 5825MHz	
4+3	Horizontal	Fundamental
Peak	<p>Site : 03CH15-14V Condition : PEAK_BE(4)_16-24 3m 91200_15_1620 HORIZONTAL Detector : Peak Project : 051232</p>	<p>Site : 03CH15-14V Condition : PEAK(UNII) 3m 91200_15_1620 HORIZONTAL Detector : Peak Project : 051232</p>



WIFI	Band 4 5725~5850MHz Band Edge @ 3m	
ANT	802.11ac VHT20 CH165 5825MHz	
4+3	Vertical	Fundamental
Peak Avg.	<div style="display: flex; justify-content: space-around;"> <div style="width: 45%;"> <p>Site : 03CH15-HY Condition : PEAK_BE(B4)_15_24 3m 91200_15_1620 VERTICAL Detector : Peak Project : 051232</p> </div> <div style="width: 45%;"> <p>Site : 03CH15-HY Condition : PEAK(UH) 3m 91200_15_1620 VERTICAL Detector : Peak Project : 051232</p> </div> </div>	



**Band 4 5725~5850MHz**  
**WIFI 802.11ac VHT40 (Band Edge @ 3m)**

WIFI	Band 4 5725~5850MHz Band Edge @ 3m	
ANT	802.11ac VHT40 CH151 5755MHz	
4+3	Horizontal	Fundamental
<b>Peak</b>	<p>Site : 03CH15-HY            Condition : PEAK_BE(B4)_15_24 3m 91200_15_1620 HORIZONTAL            : RBW:1000.000KHz VBW:3000.000KHz SWT:Auto            Detector : Peak            Project : 051232</p>	<p>Site : 03CH15-HY            Condition : PEAK(UNIT) 3m 91200_15_1620 HORIZONTAL            : RBW:1000.000KHz VBW:3000.000KHz SWT:Auto            Detector : Peak            Project : 051232</p>
<b>Peak</b>	<p>Site : 03CH15-HY            Condition : PEAK_BE(B4)_15_24 3m 91200_15_1620 HORIZONTAL            : RBW:1000.000KHz VBW:3000.000KHz SWT:Auto            Detector : Peak            Project : 051232</p>	<b>Left blank</b>



WIFI	Band 4 5725~5850MHz Band Edge @ 3m	
ANT	802.11ac VHT40 CH151 5755MHz	
4+3	Vertical	Fundamental
Peak	<p>Date: 2020-06-26 PEAK_BE(4)_15-24</p> <p>Site : 03CH15-1HY Condition : PEAK_BE(4)_15-24 3m 91200_15_1620 VERTICAL Detector : Peak Project : 051232</p>	<p>Date: 2020-06-26 PEAK(UNB)</p> <p>Site : 03CH15-1HY Condition : PEAK(UNB) 3m 91200_15_1620 VERTICAL Detector : Peak Project : 051232</p>
Peak	<p>Date: 2020-06-26 PEAK_BE(4)_15-24</p> <p>Site : 03CH15-1HY Condition : PEAK_BE(4)_15-24 3m 91200_15_1620 VERTICAL Detector : Peak Project : 051232</p>	Left blank

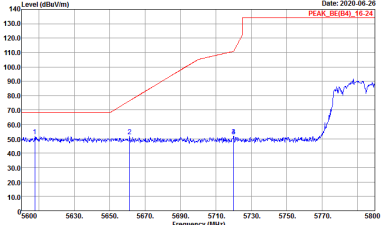
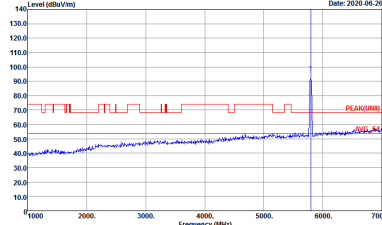
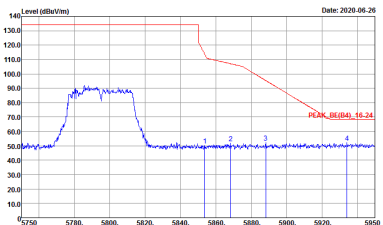

WIFI	Band 4 5725~5850MHz Band Edge @ 3m	
ANT	802.11ac VHT40 CH159 5795MHz	
4+3	Horizontal	Fundamental
Peak	 <p>Date: 2020-06-26 PEAK_BE(8)_15-24</p> <p>Site : 03CH15-HY Condition : PEAK_BE(8)_15-24 3m 91200_15_1620 HORIZONTAL RBW:1000.000kHz VBW:3000.000kHz SWT:Auto Detector : Peak Project : 051232</p>	 <p>Date: 2020-06-26</p> <p>Site : 03CH15-HY Condition : PEAK(UNII) 3m 91200_15_1620 HORIZONTAL RBW:1000.000kHz VBW:3000.000kHz SWT:Auto Detector : Peak Project : 051232</p>
Peak	 <p>Date: 2020-06-26</p> <p>Site : 03CH15-HY Condition : PEAK_BE(8)_15-24 3m 91200_15_1620 HORIZONTAL RBW:1000.000kHz VBW:3000.000kHz SWT:Auto Detector : Peak Project : 051232</p>	Left blank

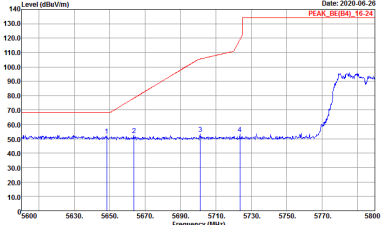
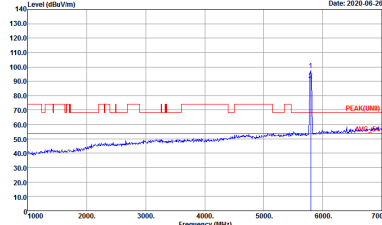
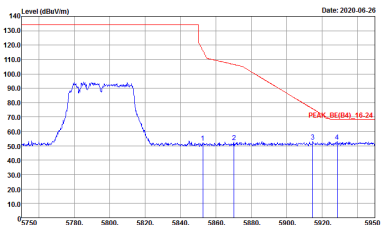

WIFI	Band 4 5725~5850MHz Band Edge @ 3m	
ANT	802.11ac VHT40 CH159 5795MHz	
4+3	Vertical	Fundamental
<p><b>Peak</b></p>	 <p>Site : 03CH15-HY            Condition : PEAK_BE(04)_15-24 3m 91200_15_1620 VERTICAL            Detector : Peak            Project : 051232</p>	 <p>Site : 03CH15-HY            Condition : PEAK(UNII) 3m 91200_15_1620 VERTICAL            Detector : Peak            Project : 051232</p>
<p><b>Peak</b></p>	 <p>Site : 03CH15-HY            Condition : PEAK_BE(04)_15-24 3m 91200_15_1620 VERTICAL            Detector : Peak            Project : 051232</p>	<p>Left blank</p>

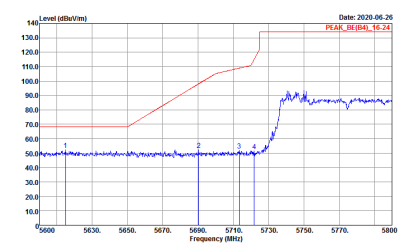
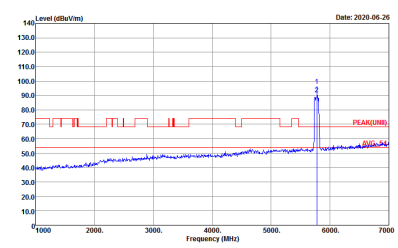
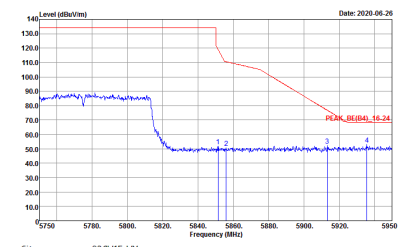

**Band 4 5725~5850MHz**  
**WIFI 802.11ac VHT80 (Band Edge @ 3m)**

WIFI	Band 4 5725~5850MHz Band Edge @ 3m	
ANT	802.11ac VHT80 CH155 5775MHz	
4+3	Horizontal	Fundamental
Peak	 <p>Site : 03CH15-HY          Condition : PEAK_BE(B4)_16-24 3m 91200_15_1620 HORIZONTAL          Detector : Peak          Project : 051232</p>	 <p>Site : 03CH15-HY          Condition : PEAK(UNIT) 3m 91200_15_1620 HORIZONTAL          Detector : Peak          Project : 051232</p>
Peak	 <p>Site : 03CH15-HY          Condition : PEAK_BE(B4)_16-24 3m 91200_15_1620 HORIZONTAL          Detector : Peak          Project : 051232</p>	Left blank

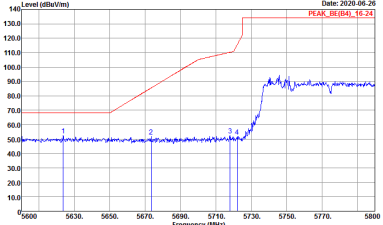
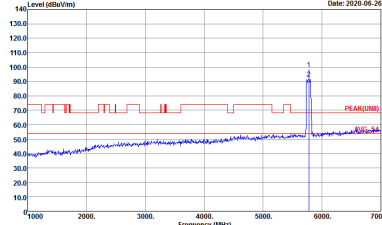
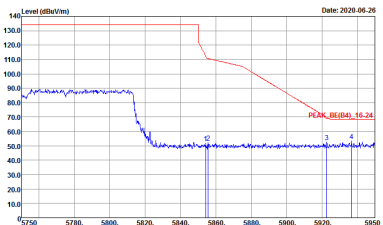

WIFI	Band 4 5725~5850MHz Band Edge @ 3m	
ANT	802.11ac VHT80 CH155 5775MHz	
4+3	Vertical	Fundamental
<p><b>Peak</b></p>	 <p>Site : 03CH15-HY            Condition : PEAK_BE(84)_15-24 3m 91200_15_1620 VERTICAL            Detector : Peak            Project : 051232</p>	 <p>Site : 03CH15-HY            Condition : PEAK(UNII) 3m 91200_15_1620 VERTICAL            Detector : Peak            Project : 051232</p>
<p><b>Peak</b></p>	 <p>Site : 03CH15-HY            Condition : PEAK_BE(84)_15-24 3m 91200_15_1620 VERTICAL            Detector : Peak            Project : 051232</p>	<p><b>Left blank</b></p>



Band 4 - 5725~5850MHz  
WIFI 802.11ac VHT20 (Harmonic @ 3m)

WIFI	Band 4 5725~5850MHz Harmonic @ 3m	
ANT	802.11ac VHT20 CH149 5745MHz	
4+3	Horizontal	Vertical
Peak Avg.	<p>Site : 03CH5-1FY Condition : PEAK(UNIT) 3m 91200_15_1620 HORIZONTAL Detector : Peak Project : 051232</p>	<p>Site : 03CH5-1FY Condition : PEAK(UNIT) 3m 91200_15_1620 VERTICAL Detector : Peak Project : 051232</p>



WIFI	Band 4 5725~5850MHz Harmonic @ 3m	
ANT	802.11ac VHT20 CH157 5785MHz	
4+3	Horizontal	Vertical
Peak Avg.	<p>Site : 03CH15-HY Condition : PEAK(UNII) 3m 91200_15_1620 HORIZONTAL Detector : Peak Project : 051232</p>	<p>Site : 03CH15-HY Condition : PEAK(UNII) 3m 91200_15_1620 VERTICAL Detector : Peak Project : 051232</p>



WIFI	Band 4 5725~5850MHz Harmonic @ 3m	
ANT	802.11ac VHT20 CH165 5825MHz	
4+3	Horizontal	Vertical
Peak Avg.	<p>Site : 03CH15-4Y Condition : PEAK(UNII) 3m 91200_15_1620 HORIZONTAL Detector : Peak Project : 051232</p>	<p>Site : 03CH15-4Y Condition : PEAK(UNII) 3m 91200_15_1620 VERTICAL Detector : Peak Project : 051232</p>



**Band 4 5725~5850MHz**  
**WIFI 802.11ac VHT40 (Harmonic @ 3m)**

<b>WIFI</b>	<b>Band 4 5725~5850MHz Harmonic @ 3m</b>	
<b>ANT</b>	<b>802.11ac VHT40 CH151 5755MHz</b>	
<b>4+3</b>	<b>Horizontal</b>	<b>Vertical</b>
<b>Peak</b> <b>Avg.</b>	<p>Site : 03CH15-HY          Condition : PEAK(UNII) 3m 91200_15_1620 HORIZONTAL          Detector : Peak          Project : 051232</p>	<p>Site : 03CH15-HY          Condition : PEAK(UNII) 3m 91200_15_1620 VERTICAL          Detector : Peak          Project : 051232</p>

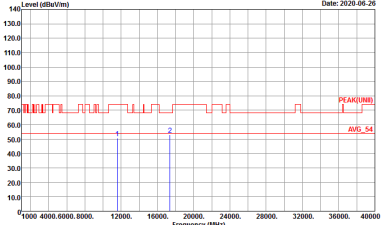
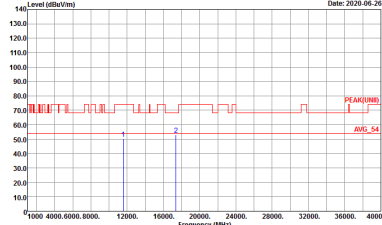

<b>WIFI</b>	<b>Band 4 5725~5850MHz Harmonic @ 3m</b>	
<b>ANT</b>	<b>802.11ac VHT40 CH159 5795MHz</b>	
<b>4+3</b>	<b>Horizontal</b>	<b>Vertical</b>
<b>Peak Avg.</b>	 <p>Site : 03CH15-4Y Condition : PEAK(UNII) 3m 91200_15_1620 HORIZONTAL Detector : Peak Project : 051232</p>	 <p>Site : 03CH15-4Y Condition : PEAK(UNII) 3m 91200_15_1620 VERTICAL Detector : Peak Project : 051232</p>



**Band 4 5725~5850MHz**  
**WIFI 802.11ac VHT80 (Harmonic @ 3m)**

<b>WIFI</b>	<b>Band 4 5725~5850MHz Harmonic @ 3m</b>	
<b>ANT</b>	<b>802.11ac VHT80 CH155 5775MHz</b>	
<b>4+3</b>	<b>Horizontal</b>	<b>Vertical</b>
<b>Peak</b> <b>Avg.</b>	<p>Site : 03CH15-HY          Condition : PEAK(UNII) 3m 91200_15_1620 HORIZONTAL          Detector : Peak          Project : 051232</p>	<p>Site : 03CH15-HY          Condition : PEAK(UNII) 3m 91200_15_1620 VERTICAL          Detector : Peak          Project : 051232</p>



Emission below 1GHz  
5GHz WIFI 802.11ac VHT20 (LF)

WIFI	5GHz 5725~5850MHz	
ANT	802.11ac VHT20 LF	
4+3	Horizontal	Vertical
QP / Peak	<p>Site : 03CH5-1FY Condition : QP 3m BTL0G_15_41912 HORIZONTAL Detector : Peak Project : 051232 Mode : 11ac(20)_Tx_LF</p>	<p>Site : 03CH5-1FY Condition : QP 3m BTL0G_15_41912 VERTICAL Detector : Peak Project : 051232 Mode : 11ac(20)_Tx_LF</p>



## Appendix E. Duty Cycle Plots

Antenna	Band	Duty Cycle(%)	T(us)	1/T(kHz)	VBW Setting	Duty Factor(dB)
4+3	802.11a for Ant 4	97.35	2020	0.50	1kHz	0.12
4+3	802.11a for Ant 3	98.06	-	-	10Hz	0.09
4+3	5GHz 802.11n HT20 for Ant 4	98.19	-	-	10Hz	0.08
4+3	5GHz 802.11n HT20 for Ant 3	97.93	1895	0.53	1kHz	0.09
4+3	5GHz 802.11n HT40 for Ant 4	95.88	930	1.08	3kHz	0.18
4+3	5GHz 802.11n HT40 for Ant 3	95.85	925	1.08	3kHz	0.18
4+3	5GHz 802.11ac VHT20 for Ant 4	97.94	1901	0.53	1kHz	0.09
4+3	5GHz 802.11ac VHT20 for Ant 3	97.15	1875	0.53	1kHz	0.13
4+3	5GHz 802.11ac VHT40 for Ant 4	95.88	980	1.02	3kHz	0.18
4+3	5GHz 802.11ac VHT40 for Ant 3	96.41	940	1.06	3kHz	0.16
4+3	5GHz 802.11ac VHT80 for Ant 4	91.84	450	2.22	3kHz	0.37
4+3	5GHz 802.11ac VHT80 for Ant 3	92.00	460	2.17	3kHz	0.36



MIMO <Ant. 4>

802.11a

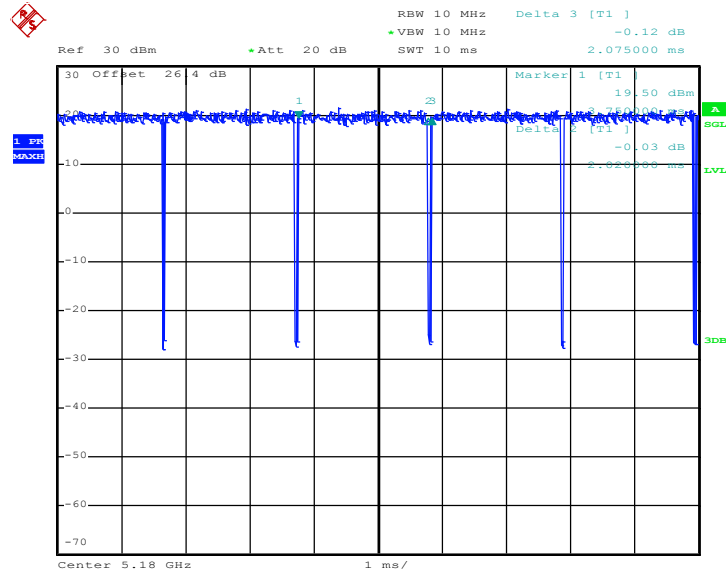

Date: 16.MAY.2020 01:16:28

802.11n HT20

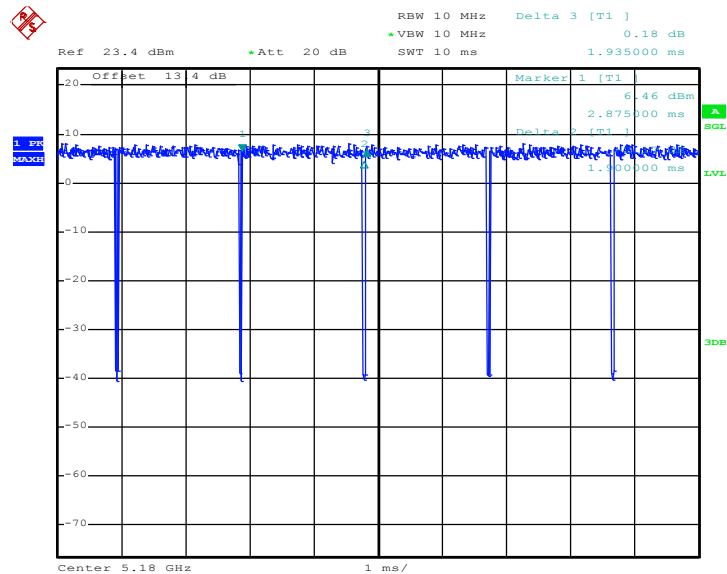

Date: 16.MAY.2020 01:15:16



802.11n HT40

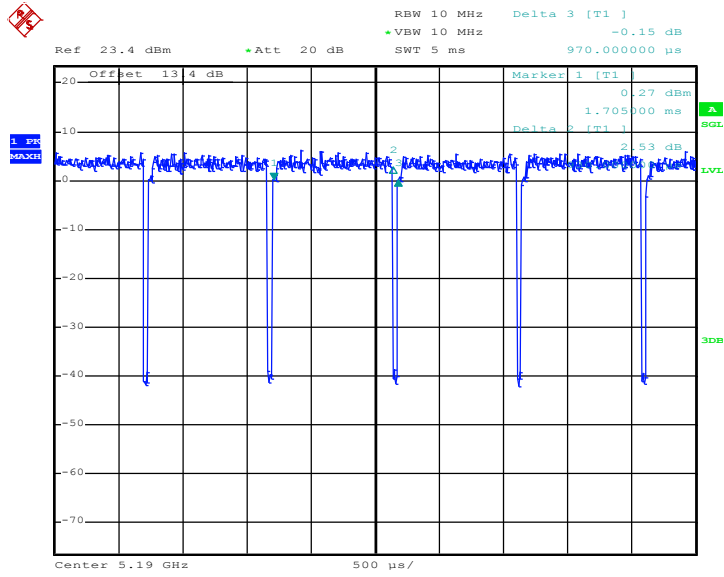

Date: 16.MAY.2020 01:19:10

802.11ac VHT20

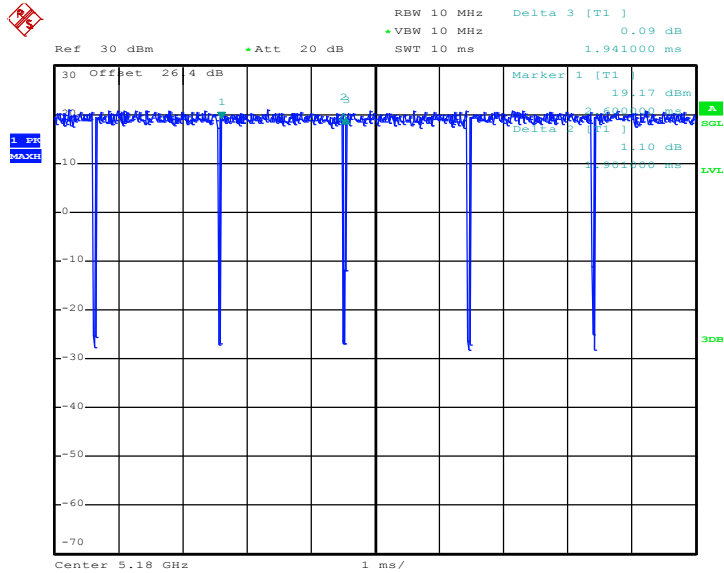

Date: 16.MAY.2020 01:12:05



802.11ac VHT40

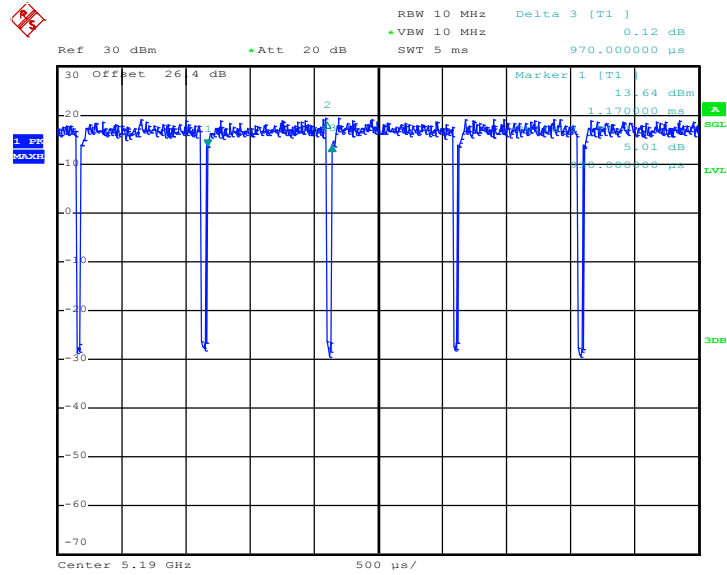

Date: 16.MAY.2020 01:05:49

802.11ac VHT80

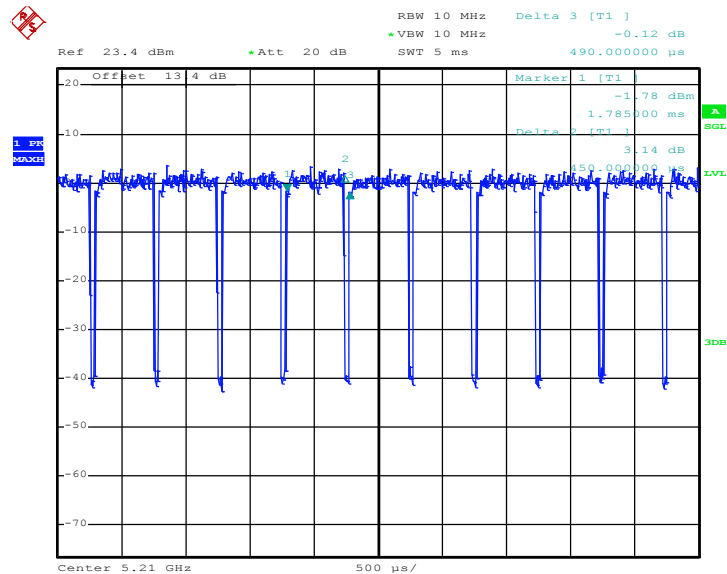

Date: 16.MAY.2020 01:10:25



MIMO <Ant. 3>

802.11a

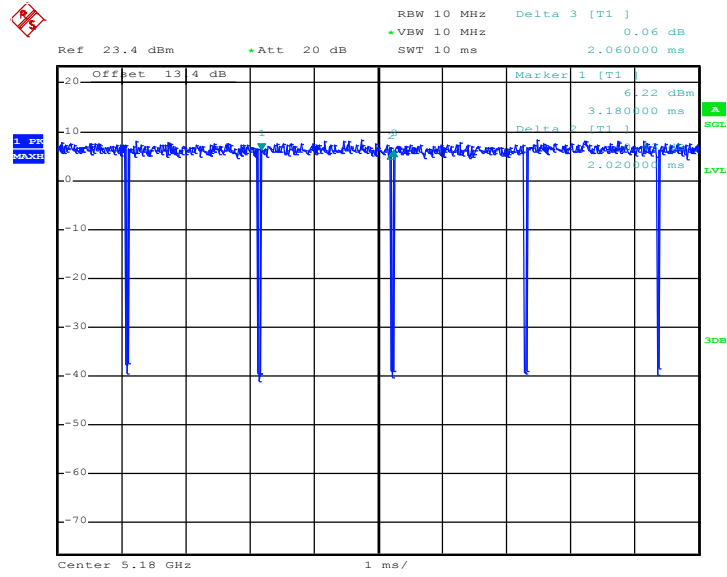

Date: 16.MAY.2020 01:17:19

802.11n HT20

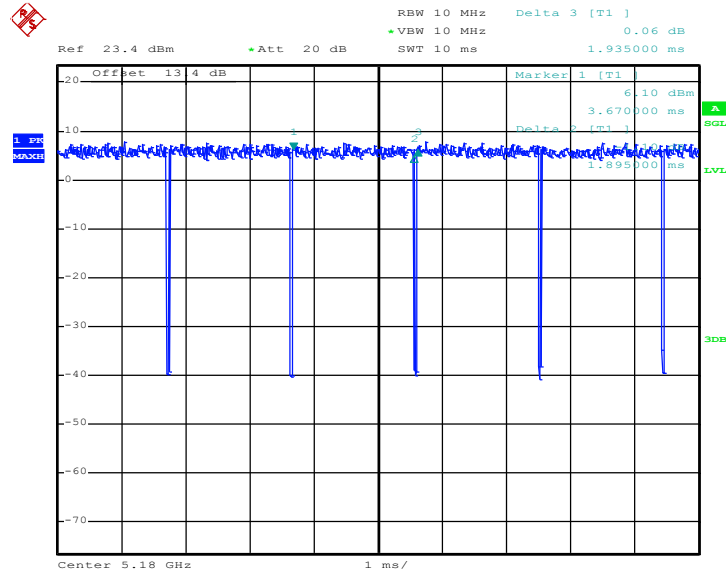

Date: 16.MAY.2020 01:14:11



802.11n HT40

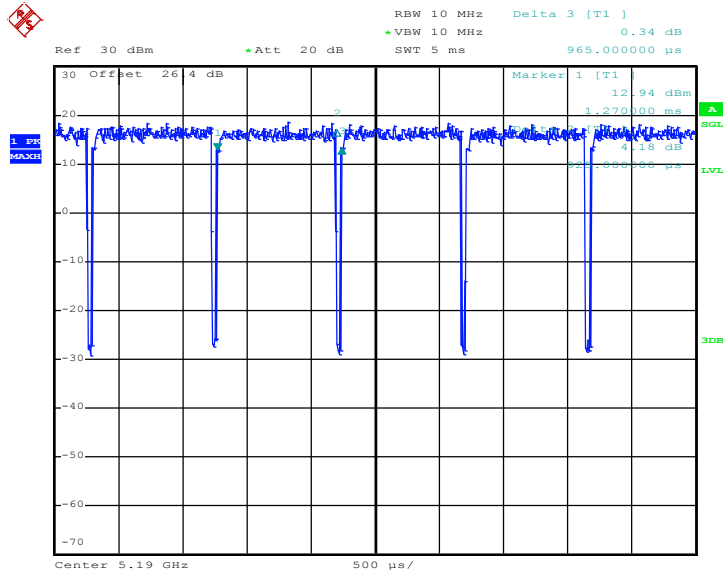

Date: 16.MAY.2020 01:18:28

802.11ac VHT20

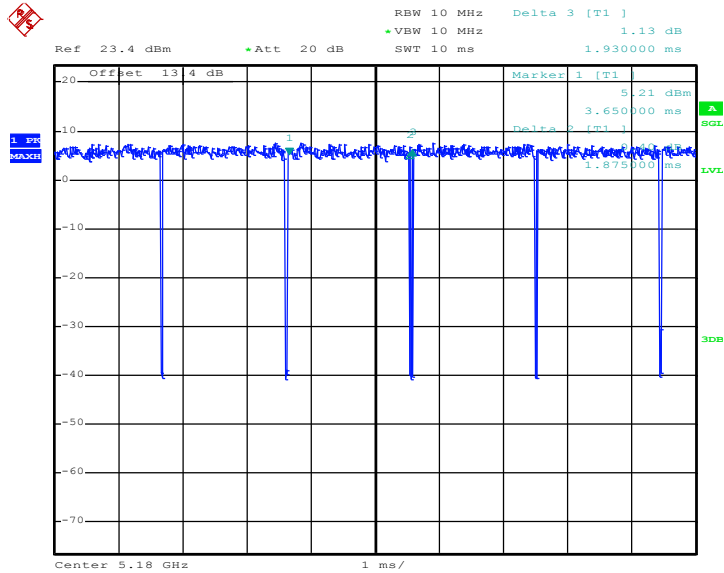

Date: 16.MAY.2020 01:12:56



802.11ac VHT40

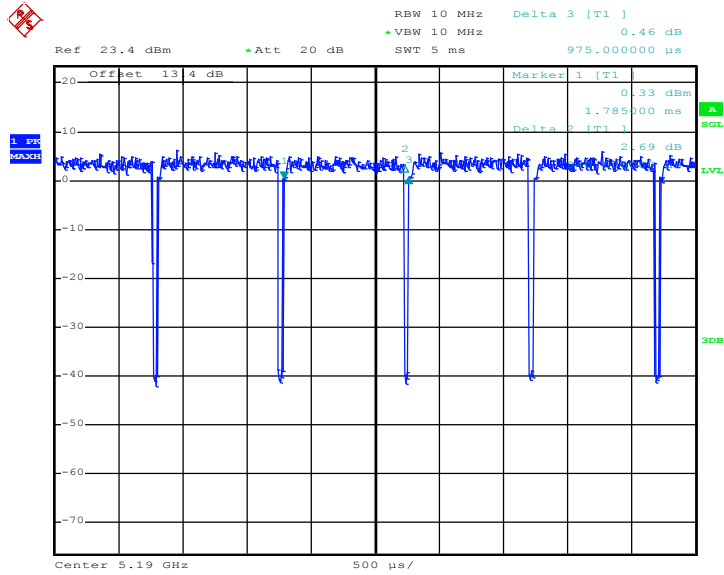

Date: 16.MAY.2020 01:07:19

802.11ac VHT80

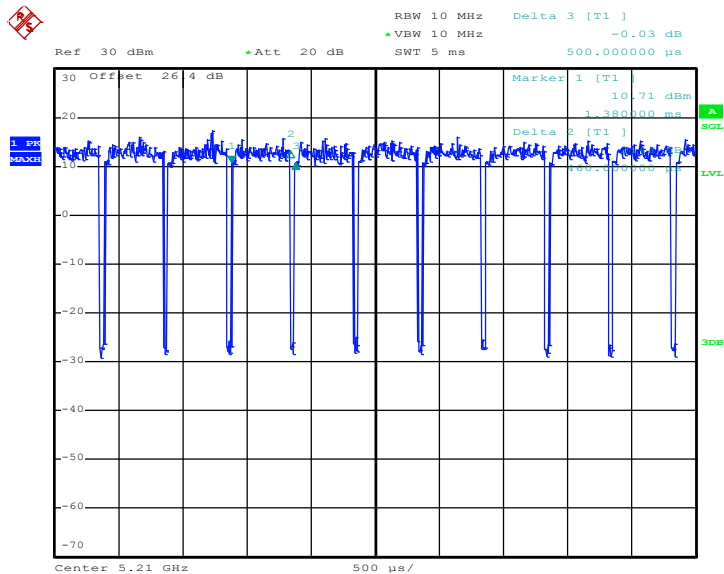

Date: 16.MAY.2020 01:09:39

—THE END—