



FCC CO-LOCATION RADIO TEST REPORT

FCC ID : IHDT56ZB2
Equipment : Mobile Cellular Phone
Brand Name : Motorola
Model Name : XT2071-4
Applicant : Motorola Mobility, LLC
222 W Merchandise Mart Plaza, Suite
1800, Chicago, IL 60654, United States
Manufacturer : Motorola Mobility, LLC
222 W Merchandise Mart Plaza, Suite
1800, Chicago, IL 60654, United States
Standard : FCC Part 15 Subpart E §15.407

The product was received on May 12, 2020 and testing was started from Jun. 25, 2020 and completed on Jun. 29, 2020. We, SPORTON INTERNATIONAL INC., EMC & Wireless Communications Laboratory, would like to declare that the tested sample has been evaluated in accordance with the test procedures and has been in compliance with the applicable technical standards.

The test results in this report apply exclusively to the tested model / sample. Without written approval of SPORTON INTERNATIONAL INC. EMC & Wireless Communications Laboratory, the test report shall not be reproduced except in full.

Louis Wu

Approved by: Louis Wu

SPORTON INTERNATIONAL INC. EMC & Wireless Communications Laboratory
No. 52, Huaya 1st Rd., Guishan Dist., Taoyuan City, Taiwan (R.O.C.)



Table of Contents

| | |
|--|-----------|
| History of this test report | 3 |
| Summary of Test Result..... | 4 |
| 1 General Description | 5 |
| 1.1 Product Feature of Equipment Under Test..... | 5 |
| 1.2 Product Specification of Equipment Under Test..... | 7 |
| 1.3 Modification of EUT | 7 |
| 1.4 Testing Location | 8 |
| 1.5 Applicable Standards..... | 8 |
| 2 Test Configuration of Equipment Under Test | 9 |
| 2.1 Carrier Frequency and Channel | 9 |
| 2.2 Test Mode..... | 9 |
| 2.3 Connection Diagram of Test System..... | 10 |
| 2.4 Support Unit used in test configuration and system | 10 |
| 2.5 EUT Operation Test Setup | 10 |
| 3 Test Result | 11 |
| 3.1 Unwanted Emissions Measurement..... | 11 |
| 3.2 Antenna Requirements..... | 15 |
| 4 List of Measuring Equipment | 16 |
| 5 Uncertainty of Evaluation | 17 |
| Appendix A. Radiated Spurious Emission | |
| Appendix B. Radiated Spurious Emission Plots | |
| Appendix C. Duty Cycle Plots | |



Summary of Test Result

| Report Clause | Ref Std. Clause | Test Items | Result (PASS/FAIL) | Remark |
|---------------|---------------------|---------------------|--------------------|---|
| 3.1 | 15.407(b) | Unwanted Emissions | Pass | Under limit 4.60 dB at 2483.520 MHz |
| 3.2 | 15.203 15.407(a) | Antenna Requirement | Pass | - |

| |
|---|
| Declaration of Conformity: The test results with all measurement uncertainty excluded are presented in accordance with the regulation limits or requirements declared by manufacturers. |
| Comments and Explanations: The declared of product specification for EUT presented in the report are provided by the manufacturer, and the manufacturer takes all the responsibilities for the accuracy of product specification. |

Reviewed by: **Wii Chang**

Report Producer: **Amy Chen**



1 General Description

1.1 Product Feature of Equipment Under Test

| Product Feature | |
|---------------------------------|--|
| Equipment | Mobile Cellular Phone |
| Brand Name | Motorola |
| Model Name | XT2071-4 |
| FCC ID | IHDT56ZB2 |
| IMEI Code | Radiation : IMEI 1: 351648110009058 IMEI 2: 351648110009066 |
| EUT supports Radios application | CDMA/EV-DO/GSM/EGPRS/WCDMA/HSPA/LTE/5G NR/ GNSS/NFC WLAN 11a/b/g/n HT20/HT40 WLAN 11ac VHT20/VHT40/VHT80 Bluetooth BR/EDR/LE |
| HW Version | DVT2 |
| EUT Stage | Identical Prototype |

Remark: The above EUT's information was declared by manufacturer.



| Accessory List | |
|---|-------------------------|
| AC Adapter 1 (US) | Brand Name : Motorola |
| | Model Name : SC-51 |
| | Manufacturer : Chenyang |
| AC Adapter 1 (EU) | Brand Name : Motorola |
| | Model Name : SC-52 |
| | Manufacturer : Chenyang |
| AC Adapter 1 (UK) | Brand Name : Motorola |
| | Model Name : SC-53UK |
| | Manufacturer : Chenyang |
| AC Adapter 1 (AR) | Brand Name : Motorola |
| | Model Name : SC-56 |
| | Manufacturer : Chenyang |
| AC Adapter 1 (AU) | Brand Name : Motorola |
| | Model Name : SC-55AU |
| | Manufacturer : Chenyang |
| AC Adapter 2 (US) | Brand Name : Motorola |
| | Model Name : SC-51 |
| | Manufacturer : Acbel |
| AC Adapter 2 (EU) | Brand Name : Motorola |
| | Model Name : SC-52 |
| | Manufacturer : Acbel |
| AC Adapter 2 (AR) | Brand Name : Motorola |
| | Model Name : SC-56 |
| | Manufacturer : Acbel |
| AC Adapter 3 (IN) | Brand Name : Motorola |
| | Model Name : SC-54 |
| | Manufacturer : Salom |
| Battery 1 | Brand Name : Motorola |
| | Model Name : LS30 |
| | Manufacturer : ATL |
| Battery 2 | Brand Name : Motorola |
| | Model Name : LS40 |
| | Manufacturer : ATL |
| Standard 3.5mm Headset 1 | Brand Name : Motorola |
| | Model Name : SH38C37773 |
| | Manufacturer : Lianyun |
| Standard 3.5mm Headset 2 | Brand Name : Motorola |
| | Model Name : SH38C44959 |
| | Manufacturer : Lianyun |
| USB-C to 3.5mm headset adaptor 1 | Brand Name : Motorola |
| | Model Name : SC18C27844 |
| USB-C to 3.5mm headset adaptor 2 | Brand Name : Motorola |
| | Model Name : SC18C27845 |
| USB Cable 1 | Brand Name : Motorola |
| | Model Name : SC18C24367 |
| | Manufacturer : Saibao |
| USB Cable 2 | Brand Name : Motorola |
| | Model Name : SC18C24368 |
| | Manufacturer : Luxshare |

1.2 Product Specification of Equipment Under Test

| Standards-related Product Specification | |
|---|---|
| Tx/Rx Frequency Range | 2400 MHz ~ 2483.5 MHz 5260 MHz ~ 5320 MHz |
| Antenna Type / Gain | Bluetooth-LE: slot Antenna type with gain -2.00 dBi WLAN: <2400 MHz ~ 2483.5 MHz> Ant. 4 : slot Antenna type with gain -2.00 dBi Ant. 3 : ILA Antenna type with gain -1.90 dBi <5260 MHz ~ 5320 MHz> Ant. 4 : slot Antenna type with gain -1.15 dBi Ant. 3 : ILA Antenna type with gain 0.40 dBi |
| Type of Modulation | Bluetooth LE : GFSK 802.11n: OFDM (BPSK / QPSK / 16QAM / 64QAM) |

1.3 Modification of EUT

No modifications are made to the EUT during all test items.



1.4 Testing Location

| | |
|---------------------------|---|
| Test Site | SPORTON INTERNATIONAL INC. EMC & Wireless Communications Laboratory |
| Test Site Location | No.58, Aly. 75, Ln. 564, Wenhua 3rd, Rd., Guishan Dist., Taoyuan City, Taiwan (R.O.C.) TEL: +886-3-327-0868 FAX: +886-3-327-0855 |
| Test Site No. | Sporton Site No. |
| | 03CH15-HY |

Note: The test site complies with ANSI C63.4 2014 requirement.

FCC designation No.: TW0007

1.5 Applicable Standards

According to the specifications of the manufacturer, the EUT must comply with the requirements of the following standards:

- ♦ FCC Part 15 Subpart E
- ♦ FCC KDB 789033 D02 General UNII Test Procedures New Rules v02r01.
- ♦ FCC KDB Publication No. 558074 D01 DTS Meas. Guidance v05r02
- ♦ FCC KDB 971168 D01 Power Meas. License Digital Systems v03r01
- ♦ FCC KDB 414788 D01 Radiated Test Site v01r01.
- ♦ FCC KDB 662911 D01 Multiple Transmitter Output v02r01.
- ♦ ANSI C63.10-2013

Remark:

1. All test items were verified and recorded according to the standards and without any deviation during the test.
2. The TAF code is not including all the FCC KDB listed without accreditation.
3. This EUT has also been tested and complied with the requirements of FCC Part 15, Subpart B, recorded in a separate test report.



2 Test Configuration of Equipment Under Test

The EUT has been associated with peripherals and configuration operated in a manner tended to maximize its emission characteristics in a typical application. Frequency range investigated: radiation emission (9 kHz to the 10th harmonic of the highest fundamental frequency or to 40 GHz, whichever is lower). For radiated measurement, pre-scanned in three orthogonal panels, X, Y, Z and Accessory (Earphone or Adapter). The worst cases (Z Plane) were recorded in this report.

2.1 Carrier Frequency and Channel

| 2400-2483.5 MHz Bluetooth-LE | | 2400-2483.5 MHz 802.11n HT20 | | 5250 MHz ~5350 MHz 802.11n HT20 | |
|---------------------------------|-------------|---------------------------------|-------------|------------------------------------|-------------|
| Channel | Freq. (MHz) | Channel | Freq. (MHz) | Channel | Freq. (MHz) |
| 39 | 2480 | 11 | 2462 | 64 | 5320 |

Remark: During the Radiated Spurious Emission test, the EUT turn on the WWAN functions simultaneously.

2.2 Test Mode

Final test modes are considering the modulation and worse data rates as below table.

<Co-Location>

| Modulation | Data Rate |
|----------------------------------|--------------|
| Bluetooth-LE + 5GHz 802.11n HT20 | 2Mbps + MCS0 |
| 2.4GHz 802.11n HT20 + LTE Band 7 | MCS0 + QPSK |

Remark: For Radiated Test Cases, the tests were performed with AC Adapter 1 (US) and USB Cable 1.

2.3 Connection Diagram of Test System

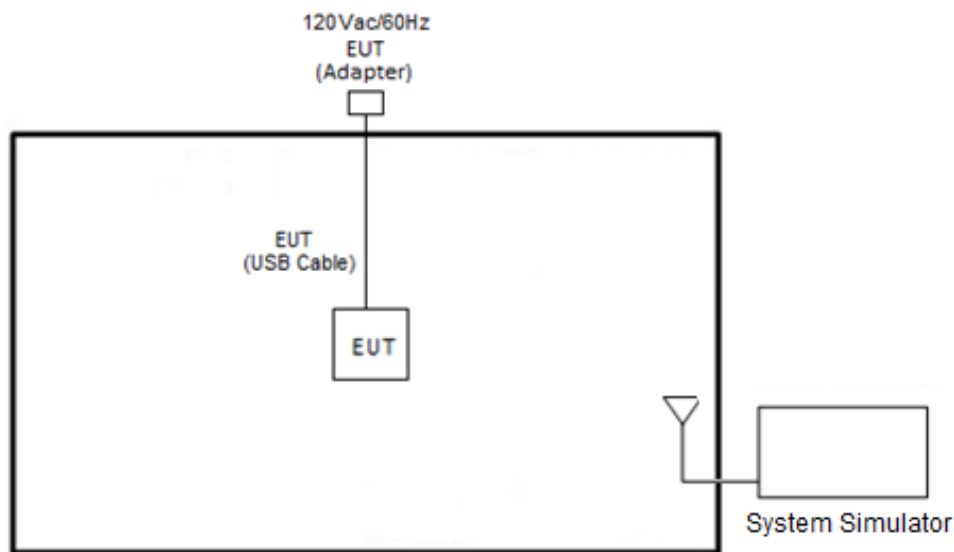
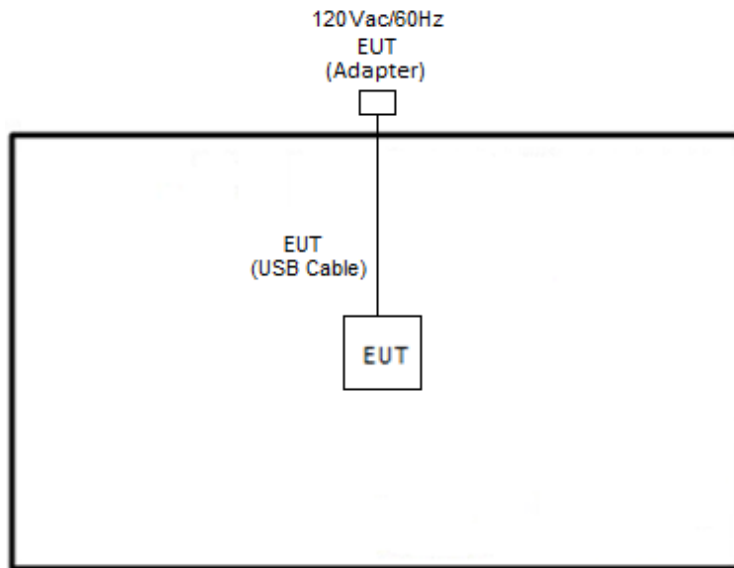

2.4 Support Unit used in test configuration and system

| Item | Equipment | Trade Name | Model Name | FCC ID | Data Cable | Power Cord |
|------|------------------|------------|------------|--------|------------|-------------------|
| 1. | LTE Base Station | Anritsu | MT8820C | N/A | N/A | Unshielded, 1.8 m |

2.5 EUT Operation Test Setup

The RF test items, utility “QRCT4 V4.0.00156.0” was installed in Notebook which was programmed in order to make the EUT get into the engineering modes to provide channel selection, power level, data rate and the application type and for continuous transmitting signals.

3 Test Result

3.1 Unwanted Emissions Measurement

This section is to measure unwanted emissions through radiated measurement for band edge spurious emissions and out of band emissions measurement.

3.1.1 Limit of Unwanted Emissions

(1) Unwanted spurious emissions fallen in restricted bands shall comply with the general field strength limits as below table:

| Frequency (MHz) | Field Strength (microvolts/meter) | Measurement Distance (meters) |
|-----------------|-----------------------------------|-------------------------------|
| 0.009 – 0.490 | 2400/F(kHz) | 300 |
| 0.490 – 1.705 | 24000/F(kHz) | 30 |
| 1.705 – 30.0 | 30 | 30 |
| 30 – 88 | 100 | 3 |
| 88 – 216 | 150 | 3 |
| 216 - 960 | 200 | 3 |
| Above 960 | 500 | 3 |

Note: The following formula is used to convert the EIRP to field strength.

$$E = \frac{1000000\sqrt{30P}}{3} \mu\text{V/m, where P is the eirp (Watts)}$$

| EIRP (dBm) | Field Strength at 3m (dBμV/m) |
|------------|-------------------------------|
| - 27 | 68.3 |

(2) KDB789033 D02 v02r01 G)2)c)

- (i) Sections 15.407(b)(1-3) specifies the unwanted emissions limit for the U-NII-1 and U-NII-2 bands. As specified, emissions above 1000 MHz that are outside of the restricted bands are subject to a peak emission limit of -27 dBm/MHz.
- (ii) Section 15.407(b)(4) specifies the unwanted emissions limit for the U-NII-3 band. A band emissions mask is specified in Section 15.407(b)(4)(i). The emission limits are based on the use of a peak detector.

3.1.2 Measuring Instruments

See list of measuring equipment of this test report.

**3.1.3 Test Procedures**

1. The testing follows FCC KDB 789033 D02 General UNII Test Procedures New Rules v02r01. Section G) Unwanted emissions measurement.
 - (1) Procedure for Unwanted Emissions Measurements Below 1000MHz
 - RBW = 120 kHz
 - VBW = 300 kHz
 - Detector = Peak
 - Trace mode = max hold
 - (2) Procedure for Peak Unwanted Emissions Measurements Above 1000 MHz
 - RBW = 1 MHz
 - VBW \geq 3 MHz
 - Detector = Peak
 - Sweep time = auto
 - Trace mode = max hold
 - (3) Procedures for Average Unwanted Emissions Measurements Above 1000MHz
 - RBW = 1 MHz
 - VBW = 10 Hz, when duty cycle is no less than 98 percent.
 - VBW \geq 1/T, when duty cycle is less than 98 percent where T is the minimum transmission duration over which the transmitter is on and is transmitting at its maximum power control level for the tested mode of operation.
2. The EUT was placed on a turntable with 0.8 meter for frequency below 1GHz and 1.5 meter for frequency above 1GHz respectively above ground.
3. The EUT was set 3 meters from the interference receiving antenna which was mounted on the top of a variable height antenna tower.
4. The antenna is a broadband antenna and its height is adjusted between one meter and four meters above ground to find the maximum value of the field strength for both horizontal polarization and vertical polarization of the antenna.
5. For each suspected emission, the EUT was arranged to its worst case and then adjust the antenna tower (from 1 m to 4 m) and turntable (from 0 degree to 360 degrees) to find the maximum reading.
6. For testing below 1GHz, if the emission level of the EUT in peak mode was 3 dB lower than the limit specified, then peak values of EUT will be reported, otherwise, the emissions will be repeated one by one using the CISPR quasi-peak method and reported.
7. For testing above 1GHz, the emission level of the EUT in peak mode was 20dB lower than average limit (that means the emission level in average mode also complies with the limit in average mode), then peak values of EUT will be reported, otherwise, the emissions will be measured in average mode again and reported.

3.1.4 Test Setup

For radiated emissions below 30MHz

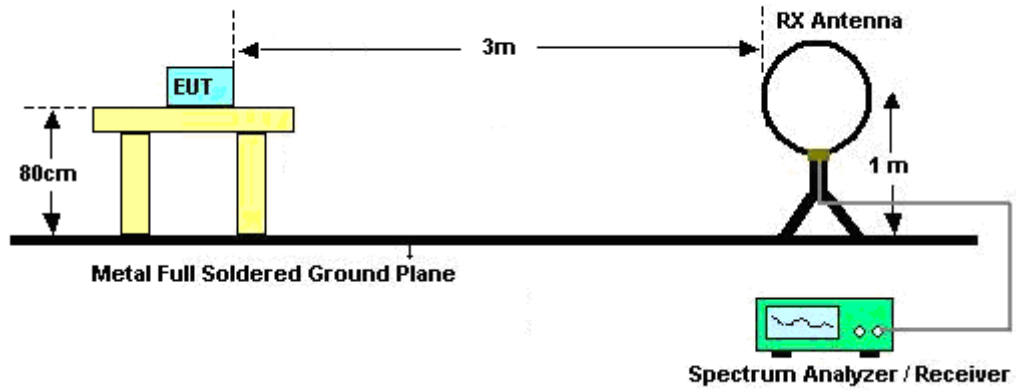

For radiated emissions from 30MHz to 1GHz

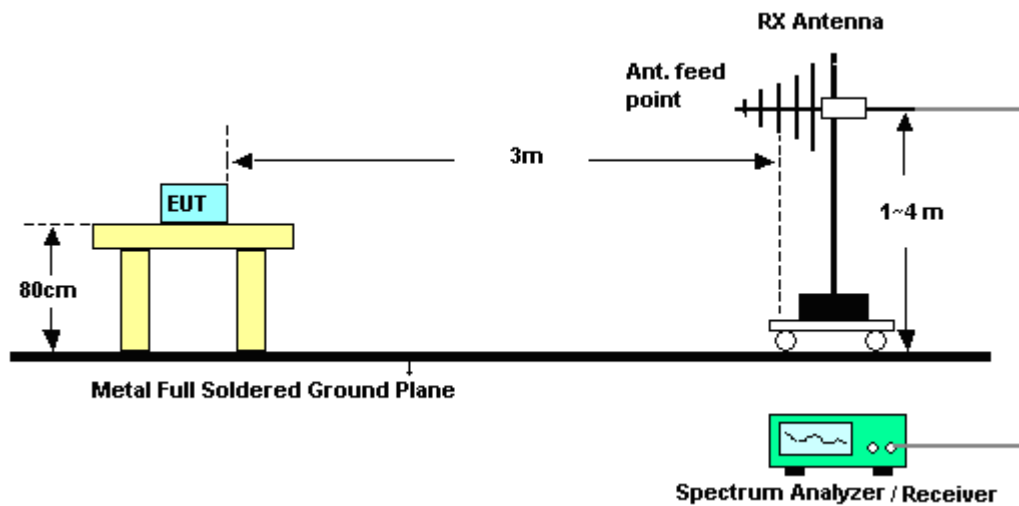

For radiated emissions above 1GHz

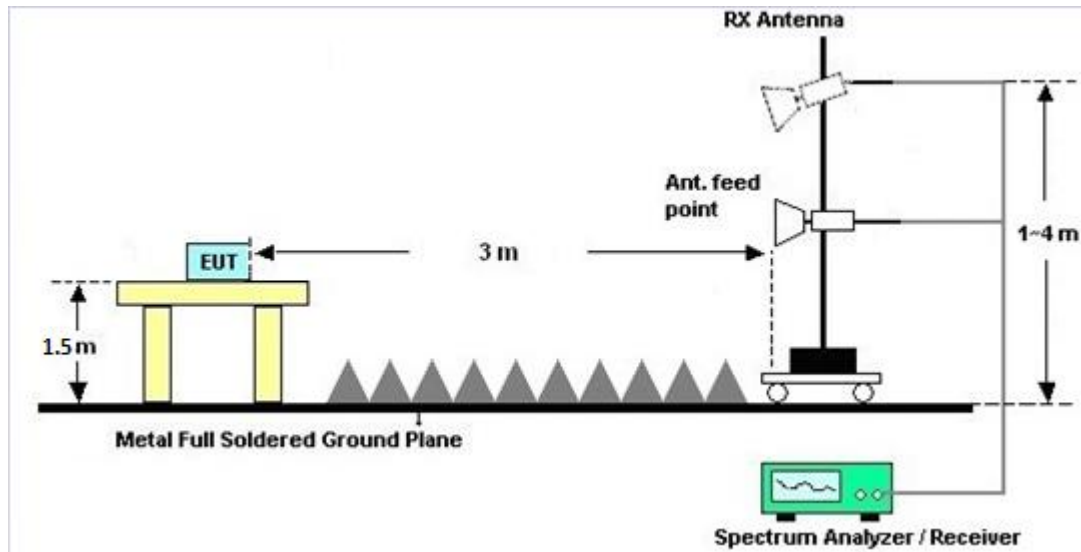

3.1.5 Test Results of Radiated Spurious Emissions (9 kHz ~ 30 MHz)

The low frequency, which started from 9 kHz to 30MHz, was pre-scanned and the result which was 20dB lower than the limit line was not reported.

There is a comparison data of both open-field test site and alternative test site - semi-Anechoic chamber according to 414788 D01 Radiated Test Site v01r01, and the result came out very similar.

3.1.6 Test Result of Radiated Spurious at Band Edges

Please refer to Appendix A and B.

3.1.7 Duty Cycle

Please refer to Appendix C.

3.1.8 Test Result of Radiated Spurious Emissions (30MHz ~ 10th Harmonic)

Please refer to Appendix A and B.



3.2 Antenna Requirements

3.2.1 Standard Applicable

If transmitting antenna directional gain is greater than 6 dBi, both the peak transmit power and the peak power spectral density shall be reduced by the amount in dB that the directional gain of the antenna exceeds 6 dBi.

3.2.2 Antenna Anti-Replacement Construction

An embedded-in antenna design is used.

3.2.3 Antenna Gain

The antenna peak gain of EUT is less than 6 dBi. Therefore, it is not necessary to reduce maximum peak output power limit.



4 List of Measuring Equipment

| Instrument | Manufacturer | Model No. | Serial No. | Characteristics | Calibration Date | Test Date | Due Date | Remark |
|----------------------|----------------|------------------------------|------------------|--------------------------|------------------|-----------------------------|---------------|-----------------------|
| Bilog Antenna | TESEQ | CBL6111D&00800N1D01N-06 | 41912&05 | 30MHz to 1GHz | Feb. 09, 2020 | Jun. 25, 2020~Jun. 29, 2020 | Feb. 08, 2021 | Radiation (03CH15-HY) |
| Amplifier | SONOMA | 310N | 363440 | 9kHz~1GHz | Dec. 27, 2019 | Jun. 25, 2020~Jun. 29, 2020 | Dec. 26, 2020 | Radiation (03CH15-HY) |
| Horn Antenna | SCHWARZBECK | BBHA 9120 D | 9120D-1620 | 1-18GHz | Oct. 28, 2019 | Jun. 25, 2020~Jun. 29, 2020 | Oct. 27, 2020 | Radiation (03CH15-HY) |
| SHF-EHF Horn Antenna | SCHWARZBECK | BBHA 9170 | BBHA9170584 | 18GHz- 40GHz | Dec. 10, 2019 | Jun. 25, 2020~Jun. 29, 2020 | Dec. 09, 2020 | Radiation (03CH15-HY) |
| Preamplifier | Jet-Power | JPA0118-55-303 | 1710001800055006 | 1GHz~18GHz | May 07, 2020 | Jun. 25, 2020~Jun. 29, 2020 | May 06, 2021 | Radiation (03CH15-HY) |
| Preamplifier | Keysight | 83017A | MY53270195 | 1GHz~26.5GHz | Aug. 23, 2019 | Jun. 25, 2020~Jun. 29, 2020 | Aug. 22, 2020 | Radiation (03CH15-HY) |
| Preamplifier | EMEC | EM18G40G | 060715 | 18GHz ~ 40GHz | Dec. 13, 2019 | Jun. 25, 2020~Jun. 29, 2020 | Dec. 12, 2020 | Radiation (03CH15-HY) |
| EMI Test Receiver | Keysight | N9038A(MXE) | MY54130085 | 20MHz~8.4GHz | Nov. 01, 2019 | Jun. 25, 2020~Jun. 29, 2020 | Oct. 31, 2020 | Radiation (03CH15-HY) |
| Spectrum Analyzer | Agilent | E4446A | MY50180136 | 3Hz~44GHz | May 04, 2020 | Jun. 25, 2020~Jun. 29, 2020 | May 03, 2021 | Radiation (03CH15-HY) |
| Antenna Mast | ChainTek | MBS-520-1 | N/A | 1m~4m | N/A | Jun. 25, 2020~Jun. 29, 2020 | N/A | Radiation (03CH15-HY) |
| Turn Table | ChainTek | T-200-S-1 | N/A | 0~360 Degree | N/A | Jun. 25, 2020~Jun. 29, 2020 | N/A | Radiation (03CH15-HY) |
| Software | Audix | E3 6.2009-8-24(k5) | RK-000451 | N/A | N/A | Jun. 25, 2020~Jun. 29, 2020 | N/A | Radiation (03CH15-HY) |
| RF Cable | HUBER + SUHNER | SUCOFLEX 104 | MY36980/4 | 30M-18G | Apr. 14, 2020 | Jun. 25, 2020~Jun. 29, 2020 | Apr. 13, 2021 | Radiation (03CH15-HY) |
| RF Cable | HUBER + SUHNER | SUCOFLEX 104 | MY9838/4PE | 30M-18G | Apr. 14, 2020 | Jun. 25, 2020~Jun. 29, 2020 | Apr. 13, 2021 | Radiation (03CH15-HY) |
| RF Cable | HUBER + SUHNER | SUCOFLEX 104 | MY37710/4 | 30M-18G | Apr. 17, 2020 | Jun. 25, 2020~Jun. 29, 2020 | Apr. 16, 2021 | Radiation (03CH15-HY) |
| RF Cable | HUBER + SUHNER | SUCOFLEX 102 | 505134/2 | 30MHz-40GHz | Feb. 25, 2020 | Jun. 25, 2020~Jun. 29, 2020 | Feb. 24, 2021 | Radiation (03CH15-HY) |
| RF Cable | HUBER + SUHNER | SUCOFLEX 102 | 800740/2 | 30MHz-40GHz | Feb. 25, 2020 | Jun. 25, 2020~Jun. 29, 2020 | Feb. 24, 2021 | Radiation (03CH15-HY) |
| Filter | Wainwright | WLK4-1000-1530-8000-40SS | SN4 | 1.53G Low Pass | Jul. 04, 2019 | Jun. 25, 2020~Jun. 29, 2020 | Jul. 03, 2020 | Radiation (03CH15-HY) |
| Filter | Wainwright | WHKX8-5872.5-6750-18000-40ST | SN6 | 6.75GHz High Pass Filter | Jul. 02, 2019 | Jun. 25, 2020~Jun. 29, 2020 | Jul. 01, 2020 | Radiation (03CH15-HY) |



5 Uncertainty of Evaluation

Uncertainty of Radiated Emission Measurement (30 MHz ~ 1000 MHz)

| | |
|---|-----|
| Measuring Uncertainty for a Level of Confidence of 95% ($U = 2Uc(y)$) | 5.0 |
|---|-----|

Uncertainty of Radiated Emission Measurement (1000 MHz ~ 18000 MHz)

| | |
|---|-----|
| Measuring Uncertainty for a Level of Confidence of 95% ($U = 2Uc(y)$) | 5.4 |
|---|-----|

Uncertainty of Radiated Emission Measurement (18000 MHz ~ 40000 MHz)

| | |
|---|-----|
| Measuring Uncertainty for a Level of Confidence of 95% ($U = 2Uc(y)$) | 5.0 |
|---|-----|



Appendix A. Radiated Spurious Emission

| | | | |
|-----------------|---------------------------------------|---------------------|-------------|
| Test Engineer : | Leo Lee, Mancy Chou, and Bigshow Wang | Temperature : | 21.4~22.9°C |
| | | Relative Humidity : | 52~61% |

BLE_Tx_Ch39+11n (n20)_Tx_Ch64 (Band Edge @ 3m)

| WIFI Ant. Simultaneously | Note | Frequency (MHz) | Level (dBμV/m) | Over Limit (dB) | Limit Line (dBμV/m) | Read Level (dBμV) | Antenna Factor (dB/m) | Path Loss (dB) | Preamp Factor (dB) | Ant Pos (cm) | Table Pos (deg) | Peak Avg. (P/A) | Pol. (H/V) | |
|--------------------------|---|-------------------|------------------|-------------------|-----------------------|---------------------|-------------------------|------------------|----------------------|----------------|-------------------|-------------------|--------------|---|
| BLE_Tx_Ch39 | * | 2480 | 96.08 | - | - | 82.13 | 27.54 | 17.51 | 31.1 | 257 | 3 | P | H | |
| | * | 2480 | 95.52 | - | - | 81.57 | 27.54 | 17.51 | 31.1 | 257 | 3 | A | H | |
| | | 2487.92 | 55.94 | -18.06 | 74 | 42 | 27.52 | 17.52 | 31.1 | 257 | 3 | P | H | |
| | | 2483.6 | 44.79 | -9.21 | 54 | 30.84 | 27.53 | 17.52 | 31.1 | 257 | 3 | A | H | |
| | | | | | | | | | | | | | H | |
| | | | | | | | | | | | | | | H |
| | * | 2480 | 93.38 | - | - | 79.43 | 27.54 | 17.51 | 31.1 | 31.1 | 242 | 78 | P | V |
| | * | 2480 | 92.79 | - | - | 78.84 | 27.54 | 17.51 | 31.1 | 31.1 | 242 | 78 | A | V |
| | | 2485.76 | 55.49 | -18.51 | 74 | 41.54 | 27.53 | 17.52 | 31.1 | 31.1 | 242 | 78 | P | V |
| | | 2483.64 | 44.76 | -9.24 | 54 | 30.81 | 27.53 | 17.52 | 31.1 | 31.1 | 242 | 78 | A | V |
| 11n(n20)_Tx_Ch64 | * | 5320 | 110.81 | - | - | 99.22 | 31.4 | 10.62 | 30.43 | 100 | 61 | P | H | |
| | * | 5320 | 102.92 | - | - | 91.33 | 31.4 | 10.62 | 30.43 | 100 | 61 | P | H | |
| | | 5351.68 | 55.26 | -18.74 | 74 | 43.64 | 31.41 | 10.64 | 30.43 | 100 | 61 | A | H | |
| | | 5350.24 | 46.85 | -7.15 | 54 | 35.24 | 31.4 | 10.64 | 30.43 | 100 | 61 | P | H | |
| | | | | | | | | | | | | | H | |
| | | | | | | | | | | | | | | H |
| | * | 5320 | 111.03 | - | - | 99.44 | 31.4 | 10.62 | 30.43 | 328 | 320 | P | V | |
| | * | 5320 | 102.78 | - | - | 91.19 | 31.4 | 10.62 | 30.43 | 328 | 320 | P | V | |
| | | 5351.68 | 56.73 | -17.27 | 74 | 45.11 | 31.41 | 10.64 | 30.43 | 328 | 320 | A | V | |
| | | 5350.08 | 45.98 | -8.02 | 54 | 34.37 | 31.4 | 10.64 | 30.43 | 328 | 320 | P | V | |
| | | | | | | | | | | | | | V | |
| | | | | | | | | | | | | | V | |
| Remark | 1. No other spurious found. 2. All results are PASS against Peak and Average limit line. | | | | | | | | | | | | | |



BLE_Tx_Ch39+11n(n20)_Tx_Ch64 (Harmonic @ 3m)

| WIFI Ant. Simultaneously | Note | Frequency (MHz) | Level (dBμV/m) | Over Limit (dB) | Limit Line (dBμV/m) | Read Level (dBμV) | Antenna Factor (dB/m) | Path Loss (dB) | Preamp Factor (dB) | Ant Pos (cm) | Table Pos (deg) | Peak Avg. (P/A) | Pol. (H/V) | |
|---------------------------------|---|-------------------|------------------|-------------------|-----------------------|---------------------|-------------------------|------------------|----------------------|----------------|-------------------|-------------------|--------------|---|
| BLE_Tx_Ch39 + 11n(n20)_Tx_Ch 64 | | 4960 | 53.91 | -20.09 | 74 | 68.78 | 31.54 | 11.85 | 58.26 | 225 | 313 | P | H | |
| | | 4960 | 48.6 | -5.4 | 54 | 63.47 | 31.54 | 11.85 | 58.26 | 225 | 313 | A | H | |
| | | 7440 | 49.43 | -24.57 | 74 | 58.06 | 36.56 | 13.4 | 58.59 | 100 | 0 | P | H | |
| | | 10640 | 52.65 | -21.35 | 74 | 57.83 | 40.16 | 15.51 | 60.85 | 100 | 0 | P | H | |
| | | 15960 | 49.43 | -24.57 | 74 | 53.86 | 36.92 | 19.02 | 60.37 | 100 | 0 | P | H | |
| | | | | | | | | | | | | | | H |
| | | | | | | | | | | | | | | H |
| | | | | | | | | | | | | | | H |
| | | | 4960 | 53.46 | -20.54 | 74 | 68.33 | 31.54 | 11.85 | 58.26 | 283 | 338 | P | V |
| | | | 4960 | 46.83 | -7.17 | 54 | 61.7 | 31.54 | 11.85 | 58.26 | 283 | 338 | A | V |
| | | | 7440 | 48.69 | -25.31 | 74 | 57.32 | 36.56 | 13.4 | 58.59 | 100 | 0 | P | V |
| | | | 10640 | 52.74 | -21.26 | 74 | 57.92 | 40.16 | 15.51 | 60.85 | 100 | 0 | P | V |
| | | | 15960 | 49.35 | -24.65 | 74 | 53.78 | 36.92 | 19.02 | 60.37 | 100 | 0 | P | V |
| | | | | | | | | | | | | | | V |
| | | | | | | | | | | | | | | V |
| | | | | | | | | | | | | | | V |
| Remark | 1. No other spurious found. 2. All results are PASS against Peak and Average limit line. | | | | | | | | | | | | | |



802.11n (n20)_Tx_Ch11+LTE Band 7 BW 20M (Band Edge @ 3m)

| WIFI Ant. Simultaneously | Note | Frequency (MHz) | Level (dBμV/m) | Over Limit (dB) | Limit Line (dBμV/m) | Read Level (dBμV) | Antenna Factor (dB/m) | Path Loss (dB) | Preamp Factor (dB) | Ant Pos (cm) | Table Pos (deg) | Peak Avg. (P/A) | Pol. (H/V) |
|---|---|-------------------|------------------|-------------------|-----------------------|---------------------|-------------------------|------------------|----------------------|----------------|-------------------|-------------------|--------------|
| 802.11n (n20)_Tx_Ch11 + LTE Band 7 BW 20M | * | 2462 | 108.65 | - | - | 94.7 | 27.58 | 17.48 | 31.11 | 200 | 52 | P | H |
| | * | 2462 | 100.42 | - | - | 86.47 | 27.58 | 17.48 | 31.11 | 200 | 52 | A | H |
| | | 2483.88 | 61.74 | -12.26 | 74 | 47.79 | 27.53 | 17.52 | 31.1 | 200 | 52 | P | H |
| | | 2483.52 | 49.4 | -4.6 | 54 | 35.45 | 27.53 | 17.52 | 31.1 | 200 | 52 | A | H |
| | | | | | | | | | | | | | H |
| | | | | | | | | | | | | | H |
| | * | 2462 | 105.1 | - | - | 91.15 | 27.58 | 17.48 | 31.11 | 261 | 52 | P | V |
| | * | 2462 | 97.26 | - | - | 83.31 | 27.58 | 17.48 | 31.11 | 261 | 52 | A | V |
| | | 2483.76 | 58.14 | -15.86 | 74 | 44.19 | 27.53 | 17.52 | 31.1 | 261 | 52 | P | V |
| | | 2483.64 | 47.86 | -6.14 | 54 | 33.91 | 27.53 | 17.52 | 31.1 | 261 | 52 | A | V |
| | | | | | | | | | | | | V | |
| | | | | | | | | | | | | V | |
| Remark | 1. No other spurious found. 2. All results are PASS against Peak and Average limit line. | | | | | | | | | | | | |



802.11n(n20)_Tx_Ch11 (Harmonic @ 3m)

| WIFI Ant. Simultaneously | Note | Frequency (MHz) | Level (dBμV/m) | Over Limit (dB) | Limit Line (dBμV/m) | Read Level (dBμV) | Antenna Factor (dB/m) | Path Loss (dB) | Preamp Factor (dB) | Ant Pos (cm) | Table Pos (deg) | Peak Avg. (P/A) | Pol. (H/V) | |
|--------------------------|---|-------------------|------------------|-------------------|-----------------------|---------------------|-------------------------|------------------|----------------------|----------------|-------------------|-------------------|--------------|---|
| 802.11n(n20)_Tx_Ch11 | | 4924 | 42.4 | -31.6 | 74 | 59.44 | 31.34 | 10.77 | 59.15 | 100 | 0 | P | H | |
| | | 7386 | 45.97 | -28.03 | 74 | 55.3 | 36.46 | 12.67 | 58.46 | 100 | 0 | P | H | |
| | | | | | | | | | | | | | H | |
| | | | | | | | | | | | | | H | |
| | | | | | | | | | | | | | H | |
| | | | 4924 | 41.07 | -32.93 | 74 | 58.11 | 31.34 | 10.77 | 59.15 | 100 | 0 | P | V |
| | | | 7386 | 45.96 | -28.04 | 74 | 55.29 | 36.46 | 12.67 | 58.46 | 100 | 0 | P | V |
| | | | | | | | | | | | | | | V |
| | | | | | | | | | | | | | | V |
| | | | | | | | | | | | | | | V |
| Remark | 1. No other spurious found. 2. All results are PASS against Peak and Average limit line. | | | | | | | | | | | | | |



Emission below 1GHz

BLE_Tx_Ch39+802.11a (n20)_Tx_Ch64 (LF @ 3m)

| WIFI | Note | Frequency | Level | Over | Limit | Read | Antenna | Path | Preamp | Ant | Table | Peak | Pol. | |
|--|--|-----------|------------|--------|------------|--------|----------|--------|--------|--------|---------|-------|-------|---|
| Ant. | | | | Limit | Line | Level | Factor | Loss | Factor | Pos | Pos | Avg. | | |
| Simultaneously | | (MHz) | (dBμV/m) | (dB) | (dBμV/m) | (dBμV) | (dB/m) | (dB) | (dB) | (cm) | (deg) | (P/A) | (H/V) | |
| BLE_Tx_Ch39+ 802.11n (n20)_Tx_Ch64 | | 72.68 | 22.53 | -17.47 | 40 | 41.25 | 12.74 | 1.12 | 32.58 | - | - | P | H | |
| | | 162.89 | 20.72 | -22.78 | 43.5 | 34.86 | 16.49 | 1.78 | 32.41 | - | - | P | H | |
| | | 329.73 | 21.98 | -24.02 | 46 | 32.35 | 19.65 | 2.45 | 32.47 | - | - | P | H | |
| | | 367.56 | 22.27 | -23.73 | 46 | 31.44 | 20.58 | 2.58 | 32.33 | - | - | P | H | |
| | | 838.01 | 35.6 | -10.4 | 46 | 34.9 | 28.49 | 4.05 | 31.84 | - | - | P | H | |
| | | 885.54 | 39.41 | -6.59 | 46 | 38.55 | 28.55 | 4.22 | 31.91 | 100 | 0 | P | H | |
| | | | | | | | | | | | | | | H |
| | | | | | | | | | | | | | | H |
| | | | | | | | | | | | | | | H |
| | | | | | | | | | | | | | | H |
| | | | | | | | | | | | | | | H |
| | | | | | | | | | | | | | | H |
| | | | 39.7 | 24.42 | -15.58 | 40 | 36.48 | 19.53 | 0.75 | 32.34 | - | - | P | V |
| | | | 72.68 | 22.52 | -17.48 | 40 | 41.24 | 12.74 | 1.12 | 32.58 | - | - | P | V |
| | | | 97.9 | 19.03 | -24.47 | 43.5 | 34.12 | 15.91 | 1.28 | 32.28 | - | - | P | V |
| | | | 260.86 | 20.9 | -25.1 | 46 | 31.44 | 19.65 | 2.24 | 32.43 | - | - | P | V |
| | | | 558.65 | 27.16 | -18.84 | 46 | 30.5 | 25.72 | 3.29 | 32.35 | - | - | P | V |
| | | | 885.54 | 38.88 | -7.12 | 46 | 38.02 | 28.55 | 4.22 | 31.91 | 100 | 0 | P | V |
| | | | | | | | | | | | | | | V |
| | | | | | | | | | | | | | | V |
| | | | | | | | | | | | | | V | |
| | | | | | | | | | | | | | V | |
| | | | | | | | | | | | | | V | |
| | | | | | | | | | | | | | V | |
| Remark | 1. No other spurious found. 2. All results are PASS against limit line. | | | | | | | | | | | | | |



LTE Band 7 20M+11n(n20)_Tx_Ch11 (LF @ 3m)

| WIFI Ant. Simultaneously | Note | Frequency (MHz) | Level (dBμV/m) | Over Limit (dB) | Limit Line (dBμV/m) | Read Level (dBμV) | Antenna Factor (dB/m) | Path Loss (dB) | Preamp Factor (dB) | Ant Pos (cm) | Table Pos (deg) | Peak Avg. (P/A) | Pol. (H/V) |
|--------------------------|--|-------------------|------------------|-------------------|-----------------------|-------------------|-------------------------|------------------|----------------------|----------------|-------------------|-----------------|------------|
| | | 60.07 | 21.03 | -18.97 | 40 | 40.45 | 12.11 | 1 | 32.53 | - | - | P | H |
| | | 73.65 | 26 | -14 | 40 | 44.57 | 12.89 | 1.12 | 32.58 | - | - | P | H |
| | | 97.9 | 24.61 | -18.89 | 43.5 | 39.7 | 15.91 | 1.28 | 32.28 | - | - | P | H |
| | | 127.97 | 24.25 | -19.25 | 43.5 | 37.53 | 17.71 | 1.48 | 32.47 | - | - | P | H |
| | | 835.1 | 32.66 | -13.34 | 46 | 32.29 | 28.19 | 4.03 | 31.85 | - | - | P | H |
| | | 903.97 | 32.82 | -13.18 | 46 | 31.81 | 28.62 | 4.29 | 31.9 | 100 | 0 | P | H |
| | | | | | | | | | | | | | H |
| | | | | | | | | | | | | | H |
| | | | | | | | | | | | | | H |
| | | | | | | | | | | | | | H |
| | | | | | | | | | | | | | H |
| | | | | | | | | | | | | | H |
| 802.11n(n20)_Tx_Ch11+ | | | | | | | | | | | | | H |
| LTE Band 7 BW 20M | | 41.64 | 29.09 | -10.91 | 40 | 41.88 | 18.77 | 0.77 | 32.33 | 100 | 0 | P | V |
| | | 68.8 | 27.86 | -12.14 | 40 | 46.55 | 12.64 | 1.08 | 32.41 | - | - | P | V |
| | | 98.87 | 19.38 | -24.12 | 43.5 | 34.3 | 16.07 | 1.28 | 32.27 | - | - | P | V |
| | | 265.71 | 19.87 | -26.13 | 46 | 30.57 | 19.48 | 2.26 | 32.44 | - | - | P | V |
| | | 730.34 | 31.61 | -14.39 | 46 | 32.99 | 27.31 | 3.75 | 32.44 | - | - | P | V |
| | | 897.18 | 32.14 | -13.86 | 46 | 31.25 | 28.57 | 4.27 | 31.95 | - | - | P | V |
| | | | | | | | | | | | | | V |
| | | | | | | | | | | | | | V |
| | | | | | | | | | | | | | V |
| | | | | | | | | | | | | | V |
| | | | | | | | | | | | | | V |
| | | | | | | | | | | | | | V |
| | | | | | | | | | | | | | V |
| Remark | 1. No other spurious found. 2. All results are PASS against limit line. | | | | | | | | | | | | |



Note symbol

| | |
|-----|--|
| * | Fundamental Frequency which can be ignored. However, the level of any unwanted emissions shall not exceed the level of the fundamental frequency. |
| ! | Test result is over limit line. |
| P/A | Peak or Average |
| H/V | Horizontal or Vertical |



A calculation example for radiated spurious emission is shown as below:

| WIFI | Note | Frequency | Level | Over | Limit | Read | Antenna | Path | Preamp | Ant | Table | Peak | Pol. |
|---------|------|-----------|------------|--------|------------|----------|----------|--------|--------|--------|---------|---------|---------|
| Ant. | | | | Limit | Line | Level | Factor | Loss | Factor | Pos | Pos | Avg. | |
| 1 | | (MHz) | (dBμV/m) | (dB) | (dBμV/m) | (dBμV) | (dB/m) | (dB) | (dB) | (cm) | (deg) | (P/A) | (H/V) |
| 802.11b | | 2390 | 55.45 | -18.55 | 74 | 54.51 | 32.22 | 4.58 | 35.86 | 103 | 308 | P | H |
| CH 01 | | | | | | | | | | | | | |
| 2412MHz | | 2390 | 43.54 | -10.46 | 54 | 42.6 | 32.22 | 4.58 | 35.86 | 103 | 308 | A | H |

1. Path Loss(dB) = Cable loss(dB) + Filter loss(dB) + Attenuator loss(dB)
2. Level(dBμV/m) =
Antenna Factor(dB/m) + Path Loss(dB) + Read Level(dBμV) - Preamp Factor(dB)
3. Over Limit(dB) = Level(dBμV/m) – Limit Line(dBμV/m)

For Peak Limit @ 2390MHz:

1. Level(dBμV/m)
= Antenna Factor(dB/m) + Path Loss(dB) + Read Level(dBμV) - Preamp Factor(dB)
= 32.22(dB/m) + 4.58(dB) + 54.51(dBμV) – 35.86 (dB)
= 55.45 (dBμV/m)
2. Over Limit(dB)
= Level(dBμV/m) – Limit Line(dBμV/m)
= 55.45(dBμV/m) – 74(dBμV/m)
= -18.55(dB)

For Average Limit @ 2390MHz:

1. Level(dBμV/m)
= Antenna Factor(dB/m) + Path Loss(dB) + Read Level(dBμV) - Preamp Factor(dB)
= 32.22(dB/m) + 4.58(dB) + 42.6(dBμV) – 35.86 (dB)
= 43.54 (dBμV/m)
2. Over Limit(dB)
= Level(dBμV/m) – Limit Line(dBμV/m)
= 43.54(dBμV/m) – 54(dBμV/m)
= -10.46(dB)

Both peak and average measured complies with the limit line, so test result is “PASS”.



Appendix B. Radiated Spurious Emission

| | | | |
|-----------------|---------------------------------------|---------------------|-------------|
| Test Engineer : | Leo Lee, Mancy Chou, and Bigshow Wang | Temperature : | 21.4~22.9°C |
| | | Relative Humidity : | 52~61% |

BLE 2400~2483.5MHz (Band Edge @ 3m)

| ANT | BLE_Tx_Ch39+802.11n (n20)_Tx_Ch64 | |
|----------------|---|--|
| Simultaneously | Horizontal | Fundamental |
| Peak | <p>Site : 03CH5-HY Condition : PEAK_BE_74 3m 91200_15_1620 HORIZONTAL Detector : Peak Project : 051232</p> | <p>Site : 03CH5-HY Condition : PEAK_74 3m 91200_15_1620 HORIZONTAL Detector : Peak Project : 051232</p> |
| Avg. | <p>Site : 03CH5-HY Condition : AVG_BE_54 3m 91200_15_1620 HORIZONTAL Detector : Peak Project : 051232</p> | <p>Site : 03CH5-HY Condition : AVG_54 3m 91200_15_1620 HORIZONTAL Detector : Peak Project : 051232</p> |



| ANT | BLE_Tx_Ch39+802.11n (n20)_Tx_Ch64 | |
|--|--|---|
| Simultaneously | Vertical | Fundamental |
| <p style="text-align: center;">Peak</p> | <p>Site : 03CH15-HY Condition : PEAK_BE_74 3m 91200_15_1620 VERTICAL Detector : Peak Project : 051232</p> | <p>Site : 03CH15-HY Condition : PEAK_74 3m 91200_15_1620 VERTICAL Detector : Peak Project : 051232</p> |
| <p style="text-align: center;">Avg.</p> | <p>Site : 03CH15-HY Condition : AVG_BE_54 3m 91200_15_1620 VERTICAL Detector : Peak Project : 051232</p> | <p>Site : 03CH15-HY Condition : AVG_54 3m 91200_15_1620 VERTICAL Detector : Peak Project : 051232</p> |

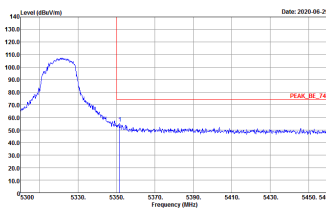
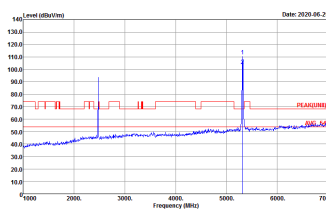
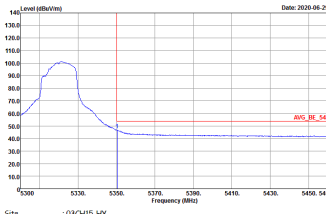

Band 2 - 5250~5350MHz (Band Edge @ 3m)

| ANT | BLE_Tx_Ch39+802.11n (n20)_Tx_Ch64 | |
|----------------|--|---|
| Simultaneously | Horizontal | Fundamental |
| Peak |  <p>Site : 03CH15-HY Condition : PEAK_BE_74 3m 91200_15_1620 HORIZONTAL RBW:1000.000KHz VBW:3000.000KHz SWT:Auto Detector : Peak Project : 051232</p> |  <p>Site : 03CH15-HY Condition : PEAK(UNIT) 3m 91200_15_1620 HORIZONTAL RBW:1000.000KHz VBW:3000.000KHz SWT:Auto Detector : Peak Project : 051232</p> |
| Avg. |  <p>Site : 03CH15-HY Condition : AVG_BE_54 3m 91200_15_1620 HORIZONTAL RBW:1000.000KHz VBW:1000KHz SWT:Auto Detector : Peak Project : 051232</p> | Left blank |

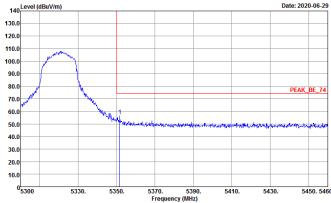
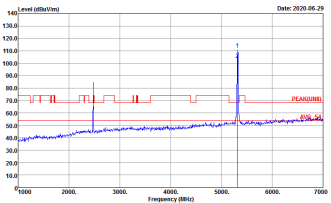
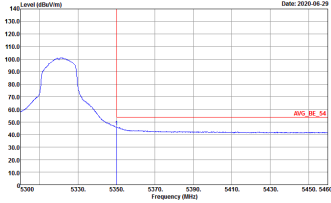

| ANT | BLE_Tx_Ch39+802.11n (n20)_Tx_Ch64 | |
|--|---|---|
| Simultaneously | Vertical | Fundamental |
| <p style="text-align: center;">Peak</p> |  <p>Site : 03CH15-HY Condition : PEAK_BE_74 3m 91200_15_1620 VERTICAL Detector : Peak Project : 051232</p> |  <p>Site : 03CH15-HY Condition : PEAK(FUND) 3m 91200_15_1620 VERTICAL Detector : Peak Project : 051232</p> |
| <p style="text-align: center;">Avg.</p> |  <p>Site : 03CH15-HY Condition : AVG_BE_54 3m 91200_15_1620 VERTICAL Detector : Peak Project : 051232</p> | <p style="text-align: center;">Left blank</p> |

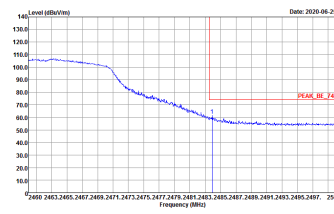
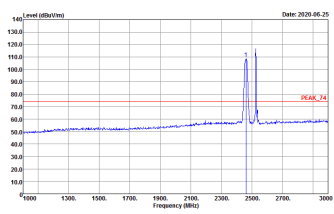
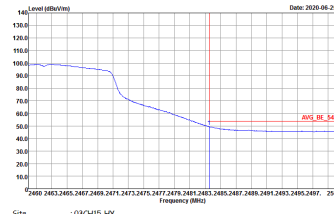
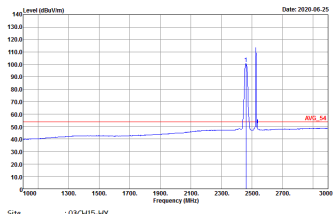

WLAN 2.4GHz 2400~2483.5MHz (Band Edge @ 3m)

| ANT | 802.11n (n20)_Tx_Ch11+LTE Band 7 BW 20M | |
|----------------|--|--|
| Simultaneously | Horizontal | Fundamental |
| Peak |  <p>Site : 03CH15-HY Condition : PEAK_BE_74 3m 91200_15_1620 HORIZONTAL : RBW:1000.0000kHz VBW:3000.0000kHz SWT:Auto Detector : Peak Project : 051232 Mode : LTE B7 20M1R80+11a(n20)_Tx_Ch11</p> |  <p>Site : 03CH15-HY Condition : PEAK_74 3m 91200_15_1620 HORIZONTAL : RBW:1000.0000kHz VBW:3000.0000kHz SWT:Auto Detector : Peak Project : 051232 Mode : LTE B7 20M1R80+11a(n20)_Tx_Ch11</p> |
| Avg. |  <p>Site : 03CH15-HY Condition : AVG_BE_54 3m 91200_15_1620 HORIZONTAL : RBW:1000.0000kHz VBW:10000Hz SWT:Auto Detector : Peak Project : 051232 Mode : LTE B7 20M1R80+11a(n20)_Tx_Ch11</p> |  <p>Site : 03CH15-HY Condition : AVG_54 3m 91200_15_1620 HORIZONTAL : RBW:1000.0000kHz VBW:10000Hz SWT:Auto Detector : Peak Project : 051232 Mode : LTE B7 20M1R80+11a(n20)_Tx_Ch11</p> |

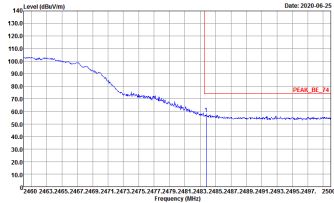
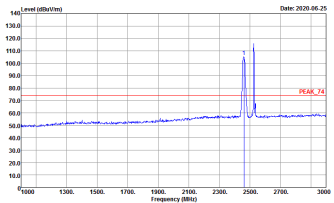
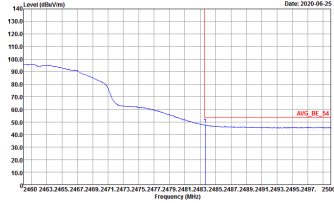
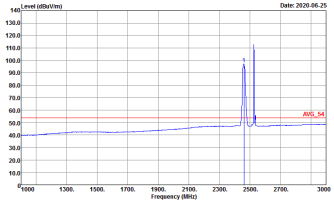

| ANT | 802.11n (n20)_Tx_Ch11+LTE Band 7 BW 20M | |
|----------------|--|--|
| Simultaneously | Vertical | Fundamental |
| Peak |  <p>Site : 03CH15-HY Condition : PEAK_95_74 3m 91200_15_1620 VERTICAL Detector : Peak Project : 051232 Mode : LTE B7 20MHzRB0-11a(n20)_Tx_Ch11</p> |  <p>Site : 03CH15-HY Condition : PEAK_74 3m 91200_15_1620 VERTICAL Detector : Peak Project : 051232 Mode : LTE B7 20MHzRB0-11a(n20)_Tx_Ch11</p> |
| Avg. |  <p>Site : 03CH15-HY Condition : AVG_BE_54 3m 91200_15_1620 VERTICAL Detector : Peak Project : 051232 Mode : LTE B7 20MHzRB0-11a(n20)_Tx_Ch11</p> |  <p>Site : 03CH15-HY Condition : AVG_54 3m 91200_15_1620 VERTICAL Detector : Peak Project : 051232 Mode : LTE B7 20MHzRB0-11a(n20)_Tx_Ch11</p> |

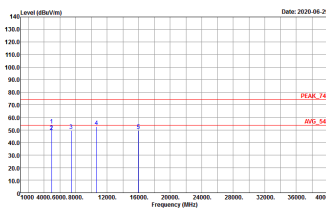
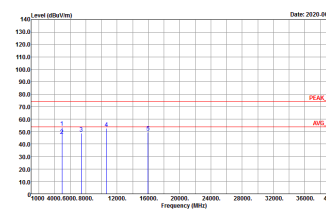

BLE_Tx_Ch39+11n(n20)_Tx_Ch64 (Harmonic @ 3m)

| ANT | BLE_Tx_Ch39+802.11n (n20)_Tx_Ch64 | |
|--|--|---|
| Simultaneously | Horizontal | Vertical |
| <p style="text-align: center;">Peak Avg.</p> |  <p>Site : 03CH15-HY Condition : PEAK_74 3m 91200_15_1620 HORIZONTAL Detector : Peak Project : 051232 Setting : 7</p> |  <p>Site : 03CH15-HY Condition : PEAK_74 3m 91200_15_1620 VERTICAL Detector : Peak Project : 051232 Setting : 7</p> |

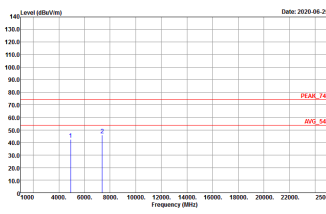
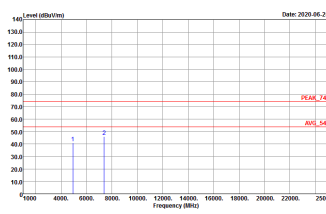

802.11n(n20)_Tx_Ch11+LTE Band 7 BW 20M (Harmonic @ 3m)

| ANT | 802.11n(n20)_Tx_Ch11+LTE Band 7 BW 20M | |
|--|---|--|
| Simultaneously | Horizontal | Vertical |
| <p style="text-align: center;">Peak Avg.</p> |  <p>Site : 03CH15-HY Condition : PEAK_74 3m 91200_15_1620 HORIZONTAL Detector : Peak Project : 051232 Mode : LTE B7 20MHzR8+11a(n20)_Tx_Ch11</p> |  <p>Site : 03CH15-HY Condition : PEAK_74 3m 91200_15_1620 VERTICAL Detector : Peak Project : 051232 Mode : LTE B7 20MHzR8+11a(n20)_Tx_Ch11</p> |



Emission below 1GHz

BLE_Tx_Ch39+802.11n (n20)_Tx_Ch64 (LF @ 3m)

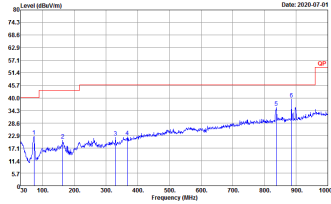
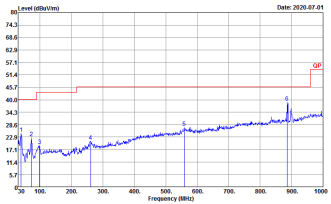
| ANT | BLE_Tx_Ch39+802.11n (n20)_Tx_Ch64 | |
|--|--|---|
| Simultaneously | Horizontal | Vertical |
| <p style="text-align: center;">Peak Avg.</p> |  <p>Site : 03CHIS-HY Condition : QP 3m-BL005_15_41912 HORIZONTAL Detector : Peak Project : 051232 Mode : BLE_Tx_Ch39-11a(n20)_Tx_Ch64</p> |  <p>Site : 03CHIS-HY Condition : QP 3m-BL005_15_41912 VERTICAL Detector : Peak Project : 051232 Mode : BLE_Tx_Ch39-11a(n20)_Tx_Ch64</p> |

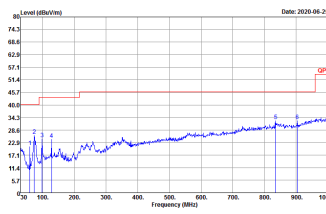
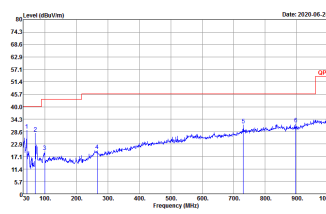

802.11n(n20)_Tx_Ch11+LTE Band 7 BW 20M (LF @ 3m)

| ANT | 802.11n(n20)_Tx_Ch11+LTE Band 7 BW 20M | |
|----------------------|---|--|
| Simultaneously | Horizontal | Vertical |
| <p>Peak Avg.</p> |  <p>Site : 03CH15-HY Condition : QP 3m 81LOG_15_41912 HORIZONTAL Detector : Peak Project : 051232 Mode : LTE B7 20MHz80+11n(n20)_Tx_Ch11</p> |  <p>Site : 03CH15-HY Condition : QP 3m 81LOG_15_41912 VERTICAL Detector : Peak Project : 051232 Mode : LTE B7 20MHz80+11n(n20)_Tx_Ch11</p> |



Appendix C. Duty Cycle Plots

| Antenna | Band | Duty Cycle(%) | T(us) | 1/T(kHz) | VBW Setting | Duty Factor(dB) |
|---------|--------------------------------|---------------|-------|----------|-------------|-----------------|
| - | Bluetooth –LE for 2Mbps | 31.75 | 200 | 5.00 | 10kHz | 4.98 |
| 4 + 3 | 2.4GHz 802.11n HT20 for Ant. 4 | 98.19 | - | - | 10Hz | 0.08 |
| 4 + 3 | 2.4GHz 802.11n HT20 for Ant. 3 | 98.19 | - | - | 10Hz | 0.08 |
| 4 + 3 | 5GHz 802.11n HT20 for Ant. 4 | 98.19 | - | - | 10Hz | 0.08 |
| 4 + 3 | 5GHz 802.11n HT20 for Ant. 3 | 97.93 | 1895 | 0.53 | 1kHz | 0.09 |



Bluetooth – LE for 2Mbps

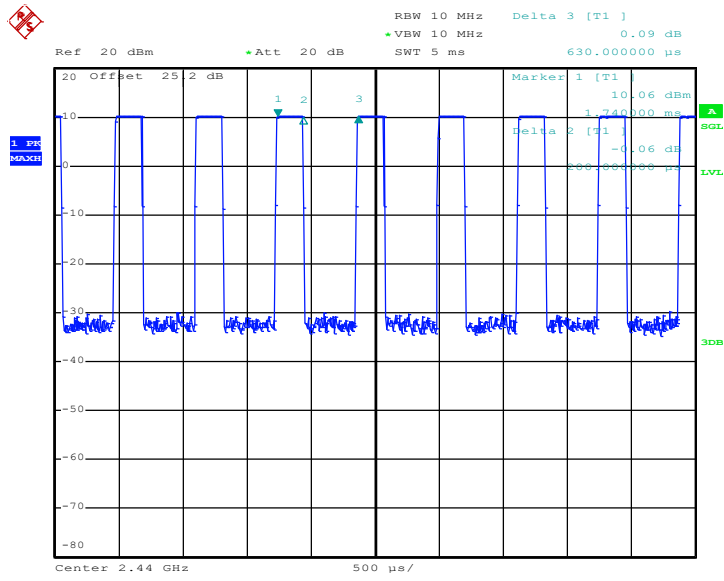



MIMO<Ant. 4 >

2.4G 802.11n HT20

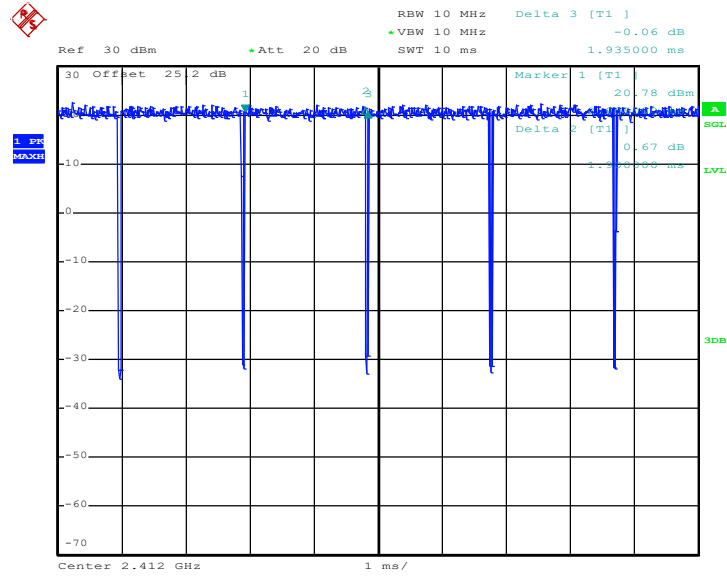

5G 802.11n HT20

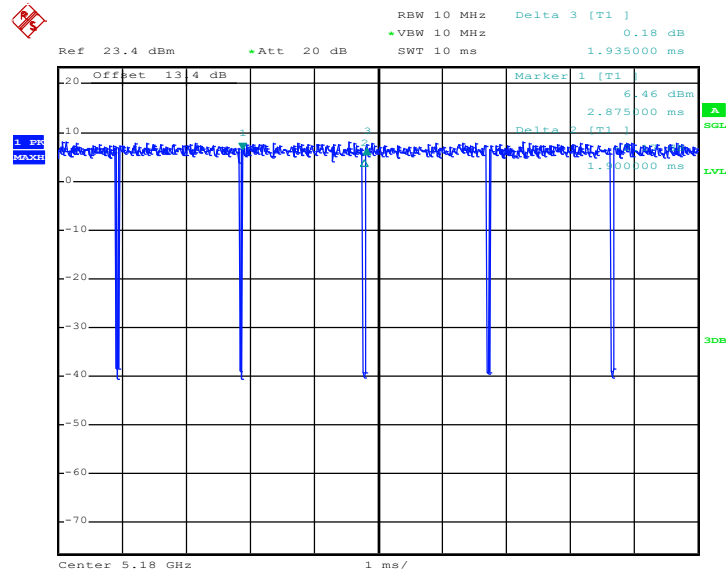



MIMO<Ant. 3>

2.4G 802.11n HT20

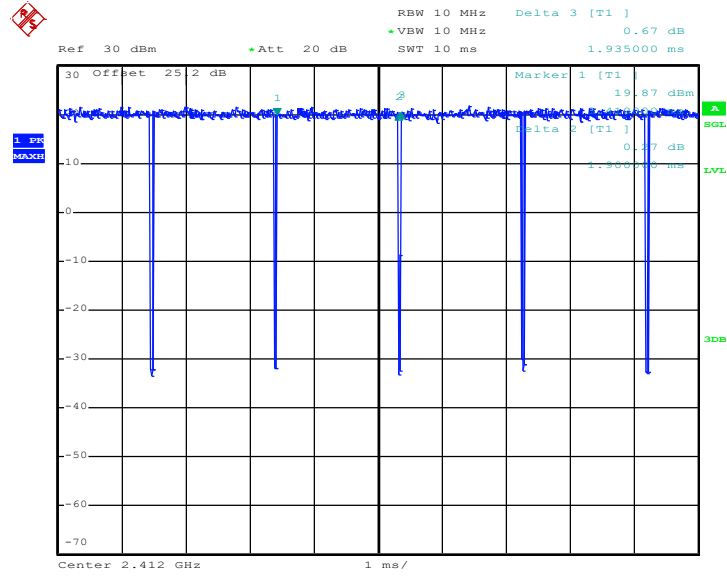

5G 802.11n HT20

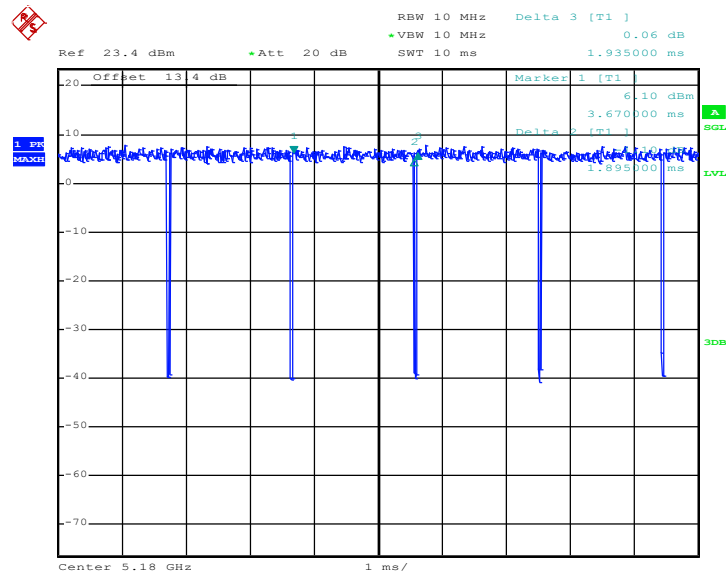

—THE END—