



# FCC RADIO TEST REPORT

**FCC ID** : IHDT56ZB1  
**Equipment** : Mobile Cellular Phone  
**Brand Name** : Motorola  
**Model Name** : XT2071-2, XT2071-3, XT2071-5  
**Applicant** : Motorola Mobility, LLC  
222 W Merchandise Mart Plaza, Suite  
1800, Chicago, IL 60654, United States  
**Manufacturer** : Motorola Mobility, LLC  
222 W Merchandise Mart Plaza, Suite  
1800, Chicago, IL 60654, United States  
**Standard** : FCC Part 15 Subpart C §15.247

The product was received on May 22, 2020 and testing was started from Jul. 08, 2020 and completed on Jul. 11, 2020. We, SPORTON INTERNATIONAL INC., EMC & Wireless Communications Laboratory, would like to declare that the tested sample has been evaluated in accordance with the test procedures and has been in compliance with the applicable technical standards.

The test results in this variant report apply exclusively to the tested model / sample. Without written approval of SPORTON INTERNATIONAL INC. EMC & Wireless Communications Laboratory, the test report shall not be reproduced except in full.

*Louis Wu*

Approved by: Louis Wu

**SPORTON INTERNATIONAL INC. EMC & Wireless Communications Laboratory**  
No. 52, Huaya 1st Rd., Guishan Dist., Taoyuan City, Taiwan (R.O.C.)



# Table of Contents

**History of this test report..... 3**

**Summary of Test Result..... 4**

**1 General Description ..... 5**

    1.1 Product Feature of Equipment Under Test..... 5

    1.2 Product Specification of Equipment Under Test..... 7

    1.3 Modification of EUT ..... 7

    1.4 Testing Location ..... 8

    1.5 Applicable Standards..... 8

**2 Test Configuration of Equipment Under Test ..... 9**

    2.1 Carrier Frequency and Channel ..... 9

    2.2 Test Mode..... 10

    2.3 Connection Diagram of Test System..... 11

    2.4 EUT Operation Test Setup ..... 11

**3 Test Result ..... 12**

    3.1 Output Power Measurement..... 12

    3.2 Radiated Band Edges and Spurious Emission Measurement ..... 13

    3.3 Antenna Requirements ..... 17

**4 List of Measuring Equipment..... 18**

**5 Uncertainty of Evaluation ..... 19**

**Appendix A. Conducted Test Results**

**Appendix B. Radiated Spurious Emission**

**Appendix C. Radiated Spurious Emission Plots**

**Appendix D. Duty Cycle Plots**





### Summary of Test Result

Report Clause	Ref Std. Clause	Test Items	Result (PASS/FAIL)	Remark
-	15.247(a)(2)	6dB Bandwidth	Not Required	-
-	2.1049	99% Occupied Bandwidth	Not Required	-
3.1	15.247(b)	Power Output Measurement	Pass	-
-	15.247(e)	Power Spectral Density	Not Required	-
-	15.247(d)	Conducted Band Edges	Not Required	-
		Conducted Spurious Emission	Not Required	-
3.2	15.247(d)	Radiated Band Edges and Radiated Spurious Emission	Pass	Under limit 3.28 dB at 2487.720 MHz
-	15.207	AC Conducted Emission	Not Required	-
3.3	15.203 & 15.247(b)	Antenna Requirement	Pass	-

**Note:**

1. Not required means after assessing, test items are not necessary to carry out.
2. This is a variant report which can be referred Product Equality Declaration. All the test cases were performed on original report which can be referred to Sporton Report Number FR051232C. Based on the original report, only worst case was verified.

<b>Declaration of Conformity:</b>
The test results with all measurement uncertainty excluded are presented in accordance with the regulation limits or requirements declared by manufacturers.
<b>Comments and Explanations:</b>
The declared of product specification for EUT presented in the report are provided by the manufacturer, and the manufacturer takes all the responsibilities for the accuracy of product specification.

**Reviewed by: Wii Chang**  
**Report Producer: Lucy Wu**



# 1 General Description

## 1.1 Product Feature of Equipment Under Test

Product Feature	
Equipment	Mobile Cellular Phone
Brand Name	Motorola
Model Name	XT2071-2, XT2071-3, XT2071-5
FCC ID	IHDT56ZB1
IMEI Code	<b>Conducted :</b> IMEI 1: 353590110016410 IMEI 2: 353590110016428
	<b>Radiation :</b> IMEI 1: 353590110017152 IMEI 2: 353590110017160
EUT supports Radios application	CDMA/EV-DO/GSM/EGPRS/WCDMA/HSPA/LTE/5G NR/ GNSS/NFC WLAN 11a/b/g/n HT20/HT40 WLAN 11ac VHT20/VHT40/VHT80 Bluetooth BR/EDR/LE
HW Version	DVT2
EUT Stage	Identical Prototype

**Remark:** The above EUT's information was declared by manufacturer.



<b>Accessory List</b>	
<b>AC Adapter 1 (US)</b>	Brand Name : Motorola
	Model Name : SC-51
	Manufacturer : Chenyang
<b>AC Adapter 1 (EU)</b>	Brand Name : Motorola
	Model Name : SC-52
	Manufacturer : Chenyang
<b>AC Adapter 1 (UK)</b>	Brand Name : Motorola
	Model Name : SC-53UK
	Manufacturer : Chenyang
<b>AC Adapter 1 (AR)</b>	Brand Name : Motorola
	Model Name : SC-56
	Manufacturer : Chenyang
<b>AC Adapter 1 (AU)</b>	Brand Name : Motorola
	Model Name : SC-55AU
	Manufacturer : Chenyang
<b>AC Adapter 2 (US)</b>	Brand Name : Motorola
	Model Name : SC-51
	Manufacturer : Acbel
<b>AC Adapter 2 (EU)</b>	Brand Name : Motorola
	Model Name : SC-52
	Manufacturer : Acbel
<b>AC Adapter 2 (AR)</b>	Brand Name : Motorola
	Model Name : SC-56
	Manufacturer : Acbel
<b>AC Adapter 3 (IN)</b>	Brand Name : Motorola
	Model Name : SC-54
	Manufacturer : Salom
<b>Battery 1</b>	Brand Name : Motorola
	Model Name : LS30
	Manufacturer : ATL
<b>Battery 2</b>	Brand Name : Motorola
	Model Name : LS40
	Manufacturer : ATL
<b>Standard 3.5mm Headset 1</b>	Brand Name : Motorola
	Model Name : SH38C37773
	Manufacturer : Lianyun
<b>Standard 3.5mm Headset 2</b>	Brand Name : Motorola
	Model Name : SH38C44959
	Manufacturer : Lianyun
<b>USB-C to 3.5mm headset adaptor 1</b>	Brand Name : Motorola
	Model Name : SC18C27844
<b>USB-C to 3.5mm headset adaptor 2</b>	Brand Name : Motorola
	Model Name : SC18C27845
<b>USB Cable 1</b>	Brand Name : Motorola
	Model Name : SC18C24367
	Manufacturer : Saibao
<b>USB Cable 2</b>	Brand Name : Motorola
	Model Name : SC18C24368
	Manufacturer : Luxshare



## 1.2 Product Specification of Equipment Under Test

Standards-related Product Specification	
<b>Tx/Rx Channel Frequency Range</b>	2412 MHz ~ 2462 MHz
<b>Maximum Output Power to antenna</b>	<b>MIMO &lt;Ant. 4+3&gt;</b> 802.11b : 23.37 dBm (0.2173 W) 802.11g : 22.74 dBm (0.1879 W) 802.11n HT20 : 22.70 dBm (0.1862 W) 802.11n HT40 : 17.71 dBm (0.0590 W)
<b>Antenna Type / Gain</b>	<Ant. 4>: Slot Antenna type with gain -2.00 dBi <Ant. 3>: ILA Antenna type with gain -1.90 dBi
<b>Type of Modulation</b>	802.11b : DSSS (DBPSK / DQPSK / CCK) 802.11g/n : OFDM (BPSK / QPSK / 16QAM / 64QAM)

**Remark:** MIMO Ant. 4+3 is a calculated result from sum of the power MIMO Ant. 4 and MIMO Ant. 3.

## 1.3 Modification of EUT

No modifications are made to the EUT during all test items.



### 1.4 Testing Location

<b>Test Site</b>	SPORTON INTERNATIONAL INC. EMC & Wireless Communications Laboratory
<b>Test Site Location</b>	No.52, Huaya 1st Rd., Guishan Dist., Taoyuan City, Taiwan (R.O.C.) TEL: +886-3-327-3456 FAX: +886-3-328-4978
<b>Test Site No.</b>	<b>Sporton Site No.</b>
	TH05-HY

**Note:** The test site complies with ANSI C63.4 2014 requirement.

<b>Test Site</b>	SPORTON INTERNATIONAL INC. EMC & Wireless Communications Laboratory
<b>Test Site Location</b>	No.58, Aly. 75, Ln. 564, Wenhua 3rd, Rd., Guishan Dist., Taoyuan City, Taiwan (R.O.C.) TEL: +886-3-327-0868 FAX: +886-3-327-0855
<b>Test Site No.</b>	<b>Sporton Site No.</b>
	03CH15-HY

**Note:** The test site complies with ANSI C63.4 2014 requirement.

FCC designation No.: TW1190 and TW0007

### 1.5 Applicable Standards

According to the specifications of the manufacturer, the EUT must comply with the requirements of the following standards:

- ♦ FCC Part 15 Subpart C §15.247
- ♦ FCC KDB Publication No. 558074 D01 DTS Meas. Guidance v05r02
- ♦ FCC KDB 414788 D01 Radiated Test Site v01r01.
- ♦ FCC KDB 662911 D01 Multiple Transmitter Output v02r01.
- ♦ ANSI C63.10-2013

**Remark:**

1. All test items were verified and recorded according to the standards and without any deviation during the test.
2. The TAF code is not including all the FCC KDB listed without accreditation.
3. This EUT has also been tested and complied with the requirements of FCC Part 15, Subpart B, recorded in a separate test report.



## 2 Test Configuration of Equipment Under Test

The EUT has been associated with peripherals and configuration operated in a manner tended to maximize its emission characteristics in a typical application. Frequency range investigated: radiation emission (9 kHz to the 10th harmonic of the highest fundamental frequency or to 40 GHz, whichever is lower). For radiated measurement, pre-scanned in three orthogonal panels, X, Y, Z and Accessory (Earphone or Adapter). The worst cases (Z plane with Adapter) were recorded in this report.

### 2.1 Carrier Frequency and Channel

Frequency Band	Channel	Freq. (MHz)	Channel	Freq. (MHz)
2400-2483.5 MHz	1	2412	7	2442
	2	2417	8	2447
	3	2422	9	2452
	4	2427	10	2457
	5	2432	11	2462
	6	2437		



## 2.2 Test Mode

Final test modes are considering the modulation and worse data rates as below table.

Modulation	Data Rate
802.11b	1 Mbps
802.11g	6 Mbps
802.11n HT20	MCS0
802.11n HT40	MCS0

Ch. #	2400-2483.5 MHz		
	802.11b	802.11n HT20	802.11n HT40
Low	-	-	-
Middle	-	-	-
High	11	11	09

**Remark:**

1. For radiation spurious emission, the final modulation and the worst data rate was reference the max RF conducted power.
2. For Radiated Test Cases, the tests were performed with AC Adapter 1 (US) and USB Cable 1.

## 2.3 Connection Diagram of Test System

<WLAN Tx Mode>

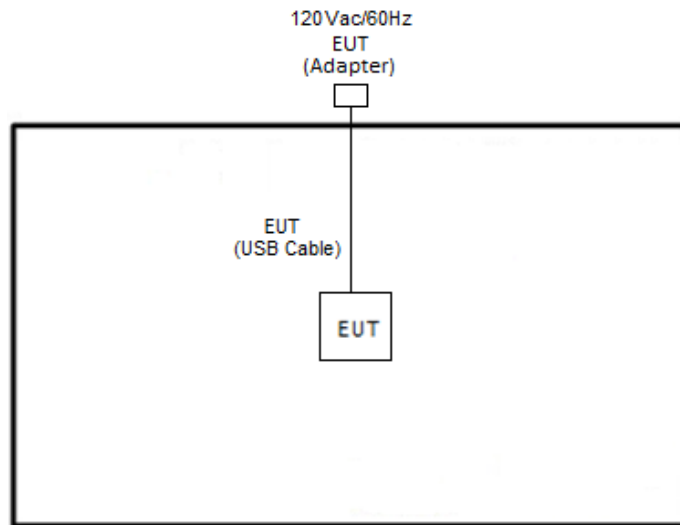

## 2.4 EUT Operation Test Setup

The RF test items, utility "QRCT V4.0.00156.0" was installed in Notebook which was programmed in order to make the EUT get into the engineering modes to provide channel selection, power level, data rate and the application type and for continuous transmitting signals.

### 3 Test Result

#### 3.1 Output Power Measurement

##### 3.1.1 Limit of Output Power

For systems using digital modulation in the 2400-2483.5MHz, the limit for output power is 30dBm. If transmitting antenna with directional gain greater than 6dBi is used, the peak output power from the intentional radiator shall be reduced below the above stated value by the amount in dB that the directional gain of the antenna exceeds 6 dBi. In case of point-to-point operation, the limit has to be reduced by 1dB for every 3dB that the directional gain of the antenna exceeds 6dBi.

##### 3.1.2 Measuring Instruments

See list of measuring equipment of this test report.

##### 3.1.3 Test Procedures

1. For Peak Power, the testing follows ANSI C63.10 Section 11.9.1.3 PKPM1
2. For Average Power, the testing follows ANSI C63.10 Section 11.9.2.3.2 Method AVGPM-G
3. The RF output of EUT was connected to the power meter by RF cable and attenuator. The path loss was compensated to the results for each measurement.
4. Set to the maximum power setting and enable the EUT transmit continuously.
5. Measure the conducted output power and record the results in the test report.
6. For MIMO mode, calculation method follows FCC KDB 662911 D01 Multiple Transmitter Output v02r01.

##### 3.1.4 Test Setup

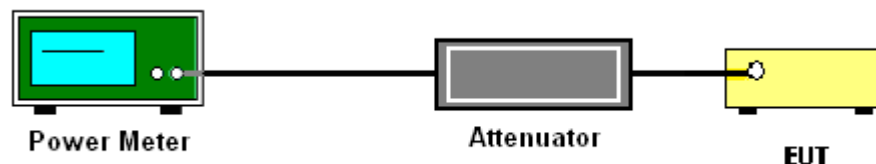

##### 3.1.5 Test Result of Peak Output Power (Reporting Only)

Please refer to Appendix A.

##### 3.1.6 Test Result of Average Output Power

Please refer to Appendix A.



### 3.2 Radiated Band Edges and Spurious Emission Measurement

#### 3.2.1 Limit of Radiated band edge and Spurious Emission Measurement

In any 100 kHz bandwidth outside the intentional radiator frequency band, all harmonics/spurious must be at least 20 dB below the highest emission level within the authorized band. If the output power of this device was measured by spectrum analyzer, the attenuation under this paragraph shall be 30 dB instead of 20 dB. In addition, radiated emissions which fall in the restricted bands must also comply with the limits as below.

Frequency (MHz)	Field Strength (microvolts/meter)	Measurement Distance (meters)
0.009 – 0.490	2400/F(kHz)	300
0.490 – 1.705	24000/F(kHz)	30
1.705 – 30.0	30	30
30 – 88	100	3
88 – 216	150	3
216 - 960	200	3
Above 960	500	3

#### 3.2.2 Measuring Instruments

See list of measuring equipment of this test report.

**3.2.3 Test Procedures**

1. The testing follows the ANSI C63.10 Section 11.12.1 Radiated emission measurements.
2. The EUT was arranged to its worst case and then tune the antenna tower (from 1 m to 4 m) and turntable (from 0 degree to 360 degrees) to find the maximum reading. A pre-amp and a high pass filter are used for the test in order to get better signal level.
3. The EUT was placed on a turntable with 0.8 meter for frequency below 1GHz and 1.5 meter for frequency above 1GHz respectively above ground.
4. The EUT was set 3 meters from the interference receiving antenna, which was mounted on the top of a variable height antenna tower.
5. Corrected Reading: Antenna Factor + Cable Loss + Read Level - Preamp Factor = Level
6. For testing below 1GHz, if the emission level of the EUT in peak mode was 3 dB lower than the limit specified, then peak values of EUT will be reported, otherwise, the emissions will be repeated one by one using the CISPR quasi-peak method and reported.
7. For testing above 1GHz, the emission level of the EUT in peak mode was 20dB lower than average limit (that means the emission level in average mode also complies with the limit in average mode), then peak values of EUT will be reported, otherwise, the emissions will be measured in average mode again and reported.
8. Use the following spectrum analyzer settings:
  - (1) Span shall wide enough to fully capture the emission being measured;
  - (2) Set RBW=100 kHz for  $f < 1$  GHz;  $VBW \geq RBW$ ; Sweep = auto; Detector function = peak; Trace = max hold;
  - (3) Set RBW = 1 MHz, VBW= 3MHz for  $f \geq 1$  GHz for peak measurement.  
For average measurement:
    - $VBW = 10$  Hz, when duty cycle is no less than 98 percent.
    - $VBW \geq 1/T$ , when duty cycle is less than 98 percent where T is the minimum transmission duration over which the transmitter is on and is transmitting at its maximum power control level for the tested mode of operation.

### 3.2.4 Test Setup

For radiated emissions below 30MHz

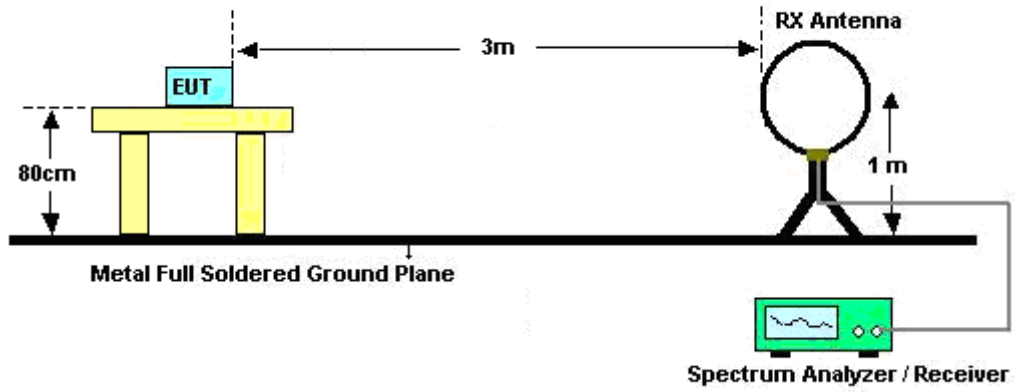

For radiated emissions from 30MHz to 1GHz

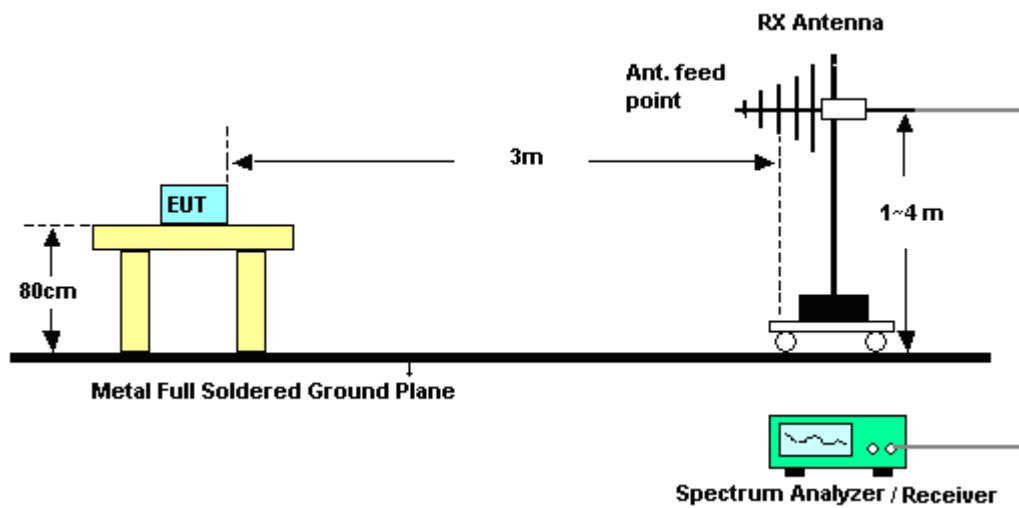

For radiated emissions above 1GHz

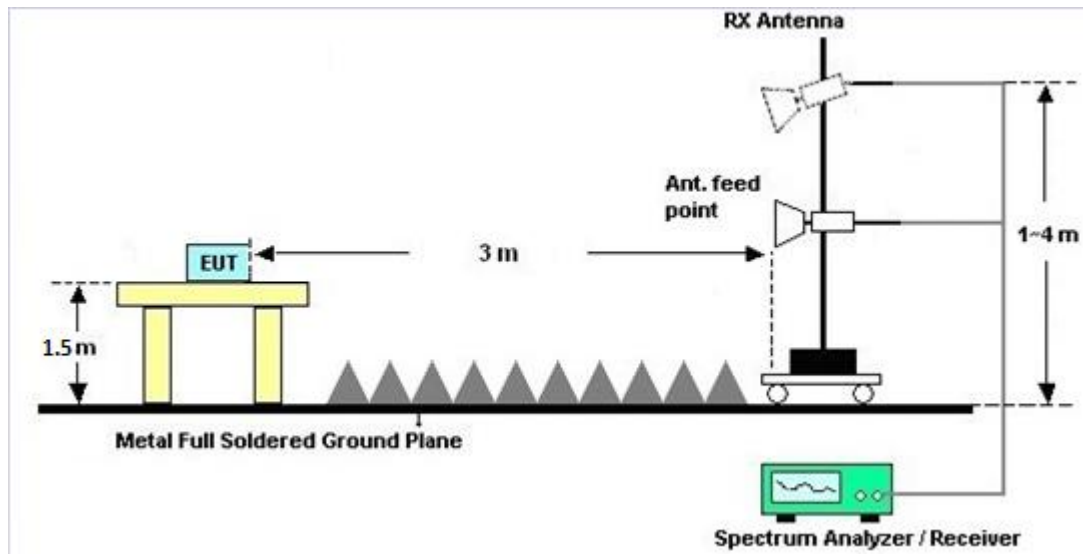

### 3.2.5 Test Results of Radiated Spurious Emissions (9kHz ~ 30MHz)

The low frequency, which started from 9 kHz to 30MHz, was pre-scanned and the result which was 20dB lower than the limit line was not reported.

There is a comparison data of both open-field test site and alternative test site - semi-Anechoic chamber according to 414788 D01 Radiated Test Site v01r01, and the result came out very similar.

### 3.2.6 Test Result of Radiated Spurious at Band Edges

Please refer to Appendix B and C.

### 3.2.7 Duty Cycle

Please refer to Appendix D.

### 3.2.8 Test Result of Radiated Spurious Emission (30MHz ~ 10<sup>th</sup> Harmonic)

Please refer to Appendix B and C.



### **3.3 Antenna Requirements**

#### **3.3.1 Standard Applicable**

If directional gain of transmitting Antennas is greater than 6dBi, the power shall be reduced by the same level in dB comparing to gain minus 6dBi. The use of a permanently attached Antenna or of an Antenna that uses a unique coupling to the intentional radiator shall be considered sufficient to comply with the rule.

#### **3.3.2 Antenna Anti-Replacement Construction**

An embedded-in antenna design is used.

#### **3.3.3 Antenna Gain**

The antenna peak gain of EUT is less than 6 dBi. Therefore, it is not necessary to reduce maximum peak output power limit.



## 4 List of Measuring Equipment

Instrument	Manufacturer	Model No.	Serial No.	Characteristics	Calibration Date	Test Date	Due Date	Remark
Hygrometer	Testo	HTC-1	2	N/A	Mar. 02, 2020	Jul. 08, 2020~ Jul. 09, 2020	Mar. 01, 2021	Conducted (TH05-HY)
Power Sensor	DARE	RPR3006W	16I00054S NO10	10MHz~6GHz	Dec. 23, 2019	Jul. 08, 2020~ Jul. 09, 2020	Dec. 22, 2020	Conducted (TH05-HY)
Signal Analyzer	Rohde & Schwarz	FSV40	101566	10Hz~40GHz	Jul. 15, 2019	Jul. 08, 2020~ Jul. 09, 2020	Jul. 14, 2020	Conducted (TH05-HY)
Switch Control Manframe	Burgeon	ETF-058	EC130048 4	N/A	Aug. 22, 2019	Jul. 08, 2020~ Jul. 09, 2020	Aug. 21, 2020	Conducted (TH05-HY)
Loop Antenna	Rohde & Schwarz	HFH2-Z2	100488	9 kHz~30 MHz	Jan. 09, 2020	Jul. 09, 2020~ Jul. 11, 2020	Jan. 08, 2021	Radiation (03CH15-HY)
Bilog Antenna	TESEQ	CBL6111D&008 00N1D01N-06	41912&05	30MHz to 1GHz	Feb. 09, 2020	Jul. 09, 2020~ Jul. 11, 2020	Feb. 08, 2021	Radiation (03CH15-HY)
Amplifier	SONOMA	310N	363440	9kHz~1GHz	Dec. 27, 2019	Jul. 09, 2020~ Jul. 11, 2020	Dec. 26, 2020	Radiation (03CH15-HY)
Horn Antenna	SCHWARZBE CK	BBHA 9120 D	9120D-162 0	1-18GHz	Oct. 28, 2019	Jul. 09, 2020~ Jul. 11, 2020	Oct. 27, 2020	Radiation (03CH15-HY)
SHF-EHF Horn Antenna	SCHWARZBE CK	BBHA 9170	BBHA9170 584	18GHz- 40GHz	Dec. 10, 2019	Jul. 09, 2020~ Jul. 11, 2020	Dec. 09, 2020	Radiation (03CH15-HY)
Preamplifier	Jet-Power	JPA0118-55-30 3	171000180 0055006	1GHz~18GHz	May 07, 2020	Jul. 09, 2020~ Jul. 11, 2020	May 06, 2021	Radiation (03CH15-HY)
Preamplifier	Keysight	83017A	MY532701 95	1GHz~26.5GHz	Aug. 23, 2019	Jul. 09, 2020~ Jul. 11, 2020	Aug. 22, 2020	Radiation (03CH15-HY)
Preamplifier	EMEC	EM18G40G	060715	18GHz ~ 40GHz	Dec. 13, 2019	Jul. 09, 2020~ Jul. 11, 2020	Dec. 12, 2020	Radiation (03CH15-HY)
EMI Test Receiver	Keysight	N9038A(MXE)	MY541300 85	20MHz~8.4GHz	Nov. 01, 2019	Jul. 09, 2020~ Jul. 11, 2020	Oct. 31, 2020	Radiation (03CH15-HY)
Spectrum Analyzer	Agilent	E4446A	MY501801 36	3Hz~44GHz	May 04, 2020	Jul. 09, 2020~ Jul. 11, 2020	May 03, 2021	Radiation (03CH15-HY)
Antenna Mast	ChainTek	MBS-520-1	N/A	1m~4m	N/A	Jul. 09, 2020~ Jul. 11, 2020	N/A	Radiation (03CH15-HY)
Turn Table	ChainTek	T-200-S-1	N/A	0~360 Degree	N/A	Jul. 09, 2020~ Jul. 11, 2020	N/A	Radiation (03CH15-HY)
Software	Audix	E3 6.2009-8-24(k5)	RK-00045 1	N/A	N/A	Jul. 09, 2020~ Jul. 11, 2020	N/A	Radiation (03CH15-HY)
RF Cable	HUBER + SUHNER	SUCOFLEX 104	MY36980/ 4	30M-18G	Apr. 14, 2020	Jul. 09, 2020~ Jul. 11, 2020	Apr. 13, 2021	Radiation (03CH15-HY)
RF Cable	HUBER + SUHNER	SUCOFLEX 104	MY9838/4 PE	30M-18G	Apr. 14, 2020	Jul. 09, 2020~ Jul. 11, 2020	Apr. 13, 2021	Radiation (03CH15-HY)
RF Cable	HUBER + SUHNER	SUCOFLEX 104	MY37710/ 4	30M-18G	Apr. 17, 2020	Jul. 09, 2020~ Jul. 11, 2020	Apr. 16, 2021	Radiation (03CH15-HY)
RF Cable	HUBER + SUHNER	SUCOFLEX 102	505134/2	30MHz-40GHz	Feb. 25, 2020	Jul. 09, 2020~ Jul. 11, 2020	Feb. 24, 2021	Radiation (03CH15-HY)
RF Cable	HUBER + SUHNER	SUCOFLEX 102	800740/2	30MHz-40GHz	Feb. 25, 2020	Jul. 09, 2020~ Jul. 11, 2020	Feb. 24, 2021	Radiation (03CH15-HY)
Filter	Wainwright	WLK4-1000-15 30-8000-40SS	SN4	1.53G Low Pass	Jul. 03, 2020	Jul. 09, 2020~ Jul. 11, 2020	Jul. 02, 2021	Radiation (03CH15-HY)
Filter	Wainwright	WHKX12-2700- 3000-18000-60 ST	SN4	3GHz High Pass Filter	Sep. 17, 2019	Jul. 09, 2020~ Jul. 11, 2020	Sep. 16, 2020	Radiation (03CH15-HY)



## 5 Uncertainty of Evaluation

### Uncertainty of Radiated Emission Measurement (30 MHz ~ 1000 MHz)

Measuring Uncertainty for a Level of Confidence of 95% ( $U = 2Uc(y)$ )	5.0
---	-----

### Uncertainty of Radiated Emission Measurement (1000 MHz ~ 18000 MHz)

Measuring Uncertainty for a Level of Confidence of 95% ( $U = 2Uc(y)$ )	5.4
---	-----

### Uncertainty of Radiated Emission Measurement (18000 MHz ~ 40000 MHz)

Measuring Uncertainty for a Level of Confidence of 95% ( $U = 2Uc(y)$ )	5.0
---	-----

**Appendix A. Test Result of Conducted Test Items**

Test Engineer:	Ryan	Temperature:	21.2~24.1	°C
Test Date:	2020/07/08~2020/07/09	Relative Humidity:	47.2~57.8	%

**TEST RESULTS DATA**  
**Peak Output Power**  
**(Reporting Only)**

2.4GHz Band MIMO																
Mod.	Data Rate	NTx	CH.	Freq. (MHz)	Peak Conducted Power (dBm)			Conducted Power Limit (dBm)		DG (dBi)		EIRP Power (dBm)		EIRP Power Limit (dBm)		Pass /Fail
					Ant4	Ant3	SUM	Ant4	Ant3	Ant4	Ant3	Ant4	Ant3	Ant4	Ant3	
11b	1Mbps	2	1	2412	22.75	20.94	24.95	30.00		-1.90		23.05		36.00		Pass
11b	1Mbps	2	6	2437	22.66	21.18	24.99	30.00		-1.90		23.09		36.00		Pass
11b	1Mbps	2	11	2462	21.67	20.11	23.97	30.00		-1.90		22.07		36.00		Pass
11g	6Mbps	2	1	2412	18.81	18.96	21.90	30.00		-1.90		20.00		36.00		Pass
11g	6Mbps	2	2	2417	21.26	20.32	23.83	30.00		-1.90		21.93		36.00		Pass
11g	6Mbps	2	6	2437	23.35	21.99	25.73	30.00		-1.90		23.83		36.00		Pass
11g	6Mbps	2	10	2457	21.37	20.33	23.89	30.00		-1.90		21.99		36.00		Pass
11g	6Mbps	2	11	2462	17.52	17.78	20.66	30.00		-1.90		18.76		36.00		Pass
HT20	MCS0	2	1	2412	18.74	18.86	21.81	30.00		-1.90		19.91		36.00		Pass
HT20	MCS0	2	2	2417	20.76	20.09	23.45	30.00		-1.90		21.55		36.00		Pass
HT20	MCS0	2	6	2437	23.35	21.86	25.68	30.00		-1.90		23.78		36.00		Pass
HT20	MCS0	2	10	2457	20.82	20.08	23.48	30.00		-1.90		21.58		36.00		Pass
HT20	MCS0	2	11	2462	17.52	17.76	20.65	30.00		-1.90		18.75		36.00		Pass
HT40	MCS0	2	3	2422	20.13	19.17	22.69	30.00		-1.90		20.79		36.00		Pass
HT40	MCS0	2	6	2437	19.17	18.35	21.79	30.00		-1.90		19.89		36.00		Pass
HT40	MCS0	2	9	2452	17.18	16.67	19.94	30.00		-1.90		18.04		36.00		Pass

Note: Measured power (dBm) has offset with cable loss.

**TEST RESULTS DATA**  
**Average Output Power**

2.4GHz Band MIMO																
Mod.	Data Rate	N <sub>TX</sub>	CH.	Freq. (MHz)	Average Conducted Power (dBm)			Conducted Power Limit (dBm)		DG (dBi)		EIRP Power (dBm)		EIRP Power Limit (dBm)		Pass /Fail
					Ant4	Ant3	SUM	Ant4	Ant3	Ant4	Ant3	Ant4	Ant3	Ant4	Ant3	
11b	1Mbps	2	1	2412	20.90	19.40	23.22	30.00		-1.90		21.32		36.00		Pass
11b	1Mbps	2	6	2437	21.00	19.60	23.37	30.00		-1.90		21.47		36.00		Pass
11b	1Mbps	2	11	2462	19.80	18.50	22.21	30.00		-1.90		20.31		36.00		Pass
11g	6Mbps	2	1	2412	14.50	15.10	17.82	30.00		-1.90		15.92		36.00		Pass
11g	6Mbps	2	2	2417	17.20	17.20	20.21	30.00		-1.90		18.31		36.00		Pass
11g	6Mbps	2	6	2437	20.20	19.20	22.74	30.00		-1.90		20.84		36.00		Pass
11g	6Mbps	2	10	2457	17.30	17.10	20.21	30.00		-1.90		18.31		36.00		Pass
11g	6Mbps	2	11	2462	13.20	13.70	16.47	30.00		-1.90		14.57		36.00		Pass
HT20	MCS0	2	1	2412	14.40	14.90	17.67	30.00		-1.90		15.77		36.00		Pass
HT20	MCS0	2	2	2417	16.60	16.90	19.76	30.00		-1.90		17.86		36.00		Pass
HT20	MCS0	2	6	2437	20.20	19.10	22.70	30.00		-1.90		20.80		36.00		Pass
HT20	MCS0	2	10	2457	16.50	16.60	19.56	30.00		-1.90		17.66		36.00		Pass
HT20	MCS0	2	11	2462	13.00	13.50	16.27	30.00		-1.90		14.37		36.00		Pass
HT40	MCS0	2	3	2422	14.90	14.50	17.71	30.00		-1.90		15.81		36.00		Pass
HT40	MCS0	2	6	2437	13.50	14.20	16.87	30.00		-1.90		14.97		36.00		Pass
HT40	MCS0	2	9	2452	11.90	11.70	14.81	30.00		-1.90		12.91		36.00		Pass

Note: Measured power (dBm) has offset with cable loss.



### Appendix B. Radiated Spurious Emission

Test Engineer :	Leo Lee, Mancy Chou and Bigshow Wang	Temperature :	22.1~23.1°C
		Relative Humidity :	52~61%

<Open Mode>

2.4GHz 2400~2483.5MHz

WIFI 802.11b (Band Edge @ 3m)

WIFI Ant.	Note	Frequency ( MHz )	Level ( dBμV/m )	Over Limit ( dB )	Limit Line ( dBμV/m )	Read Level ( dBμV )	Antenna Factor ( dB/m )	Path Loss ( dB )	Preamp Factor ( dB )	Ant Pos ( cm )	Table Pos ( deg )	Peak Avg. ( P/A )	Pol. ( H/V )	
802.11b CH 11 2462MHz	*	2462	112.68	-	-	98.73	27.58	17.48	31.11	100	47	P	H	
	*	2462	109.5	-	-	95.55	27.58	17.48	31.11	100	47	A	H	
		2488.88	58.04	-15.96	74	44.09	27.52	17.53	31.1	100	47	P	H	
		2488.72	48.42	-5.58	54	34.47	27.52	17.53	31.1	100	47	A	H	
													H	
														H
	*	2462	107.3	-	-	93.35	27.58	17.48	31.11	272	2	P	V	
	*	2460	104.01	-	-	90.07	27.58	17.47	31.11	272	2	A	V	
		2487.12	58.84	-15.16	74	44.89	27.53	17.52	31.1	272	2	P	V	
		2487.72	50.72	-3.28	54	36.78	27.52	17.52	31.1	272	2	A	V	
													V	
													V	
Remark	1. No other spurious found. 2. All results are PASS against Peak and Average limit line.													



**2.4GHz 2400~2483.5MHz  
WIFI 802.11b (Harmonic @ 3m)**

WIFI Ant. 4+3	Note	Frequency ( MHz )	Level ( dBμV/m )	Over Limit ( dB )	Limit Line ( dBμV/m )	Read Level ( dBμV )	Antenna Factor ( dB/m )	Path Loss ( dB )	Preamp Factor ( dB )	Ant Pos ( cm )	Table Pos ( deg )	Peak Avg. (P/A)	Pol. (H/V)	
802.11b CH 11 2462MHz		4924	40.85	-33.15	74	57.89	31.34	10.77	59.15	100	0	P	H	
		7386	47.49	-26.51	74	56.82	36.46	12.67	58.46	100	0	P	H	
													H	
													H	
			4924	41.17	-32.83	74	58.21	31.34	10.77	59.15	100	0	P	V
			7386	47.71	-26.29	74	57.04	36.46	12.67	58.46	100	0	P	V
														V
														V
<b>Remark</b>	1. No other spurious found. 2. All results are PASS against Peak and Average limit line.													



**2.4GHz 2400~2483.5MHz  
WIFI 802.11n HT20 (Band Edge @ 3m)**

WIFI Ant. 4+3	Note	Frequency ( MHz )	Level ( dBμV/m )	Over Limit ( dB )	Limit Line ( dBμV/m )	Read Level ( dBμV )	Antenna Factor ( dB/m )	Path Loss ( dB )	Preamp Factor ( dB )	Ant Pos ( cm )	Table Pos ( deg )	Peak Avg. ( P/A )	Pol. ( H/V )
802.11n HT20 CH 11 2462MHz	*	2462	108.13	-	-	94.18	27.58	17.48	31.11	100	48	P	H
	*	2462	100.86	-	-	86.91	27.58	17.48	31.11	100	48	A	H
		2483.68	59.68	-14.32	74	45.73	27.53	17.52	31.1	100	48	P	H
		2483.52	48.98	-5.02	54	35.03	27.53	17.52	31.1	100	48	A	H
													H
													H
	*	2462	103.44	-	-	89.49	27.58	17.48	31.11	250	56	P	V
	*	2462	95.33	-	-	81.38	27.58	17.48	31.11	250	56	A	V
		2493.4	56.57	-17.43	74	42.62	27.51	17.53	31.09	250	56	P	V
		2483.52	46.04	-7.96	54	32.09	27.53	17.52	31.1	250	56	A	V
												V	
												V	
<b>Remark</b>	1. No other spurious found. 2. All results are PASS against Peak and Average limit line.												



**2.4GHz 2400~2483.5MHz  
WIFI 802.11n HT20 (Harmonic @ 3m)**

WIFI Ant. 4+3	Note	Frequency ( MHz )	Level ( dBμV/m )	Over Limit ( dB )	Limit Line ( dBμV/m )	Read Level ( dBμV )	Antenna Factor ( dB/m )	Path Loss ( dB )	Preamp Factor ( dB )	Ant Pos ( cm )	Table Pos ( deg )	Peak Avg. (P/A)	Pol. (H/V)
802.11n HT20 CH 11		4924	40.39	-33.61	74	57.43	31.34	10.77	59.15	100	0	P	H
		7386	44.83	-29.17	74	54.16	36.46	12.67	58.46	100	0	P	H
													H
													H
2462MHz		4924	40.19	-33.81	74	57.23	31.34	10.77	59.15	100	0	P	V
		7386	44.66	-29.34	74	53.99	36.46	12.67	58.46	100	0	P	V
													V
													V
<b>Remark</b>	1. No other spurious found. 2. All results are PASS against Peak and Average limit line.												



2.4GHz 2400~2483.5MHz
WIFI 802.11n HT40 (Band Edge @ 3m)

Table with 14 columns: WIFI Ant. 4+3, Note, Frequency (MHz), Level (dBµV/m), Over Limit (dB), Limit Line (dBµV/m), Read Level (dBµV), Antenna Factor (dB/m), Path Loss (dB), Preamp Factor (dB), Ant Pos (cm), Table Pos (deg), Peak Avg. (P/A), Pol. (H/V). Rows include frequencies from 2318.48 to 2483.8 MHz with various level and limit values.



**2.4GHz 2400~2483.5MHz  
WIFI 802.11n HT40 (Harmonic @ 3m)**

WIFI Ant. 4+3	Note	Frequency ( MHz )	Level ( dBμV/m )	Over Limit ( dB )	Limit Line ( dBμV/m )	Read Level ( dBμV )	Antenna Factor ( dB/m )	Path Loss ( dB )	Preamp Factor ( dB )	Ant Pos ( cm )	Table Pos ( deg )	Peak Avg. (P/A)	Pol. (H/V)
802.11n HT40 CH 09		4904	40.42	-33.58	74	57.59	31.22	10.75	59.14	100	0	P	H
		7356	45.1	-28.9	74	54.4	36.58	12.62	58.5	100	0	P	H
													H
													H
2452MHz		4904	41.27	-32.73	74	58.44	31.22	10.75	59.14	100	0	P	V
		7356	44.97	-29.03	74	54.27	36.58	12.62	58.5	100	0	P	V
													V
													V
<b>Remark</b>	1. No other spurious found. 2. All results are PASS against Peak and Average limit line.												



Emission below 1GHz  
2.4GHz WIFI 802.11b (LF)

WIFI	Note	Frequency	Level	Over	Limit	Read	Antenna	Path	Preamp	Ant	Table	Peak	Pol.	
Ant.				Limit	Line	Level	Factor	Loss	Factor	Pos	Pos	Avg.		
4+3		( MHz )	( dBμV/m )	( dB )	( dBμV/m )	( dBμV )	( dB/m )	( dB )	( dB )	( cm )	( deg )	( P/A )	( H/V )	
2.4GHz 802.11b LF		72.68	22.42	-17.58	40	41.13	12.74	1.13	32.58	-	-	P	H	
		161.92	20.19	-23.31	43.5	34.24	16.61	1.76	32.42	-	-	P	H	
		259.89	23.84	-22.16	46	34.35	19.64	2.28	32.43	-	-	P	H	
		308.39	22.3	-23.7	46	33.23	19.17	2.41	32.51	-	-	P	H	
		713.85	33.47	-12.53	46	35.59	26.57	3.72	32.41	100	0	P	H	
		718.7	32.22	-13.78	46	34.08	26.83	3.73	32.42	-	-	P	H	
														H
														H
														H
														H
														H
														H
			38.73	21.36	-18.64	40	32.9	20	0.8	32.34	-	-	P	V
			72.68	22.37	-17.63	40	41.08	12.74	1.13	32.58	-	-	P	V
			118.27	22.9	-20.6	43.5	36.3	17.52	1.5	32.42	-	-	P	V
			209.45	22.49	-21.01	43.5	37.94	14.88	2.06	32.39	-	-	P	V
			245.34	25.78	-20.22	46	38.35	17.6	2.24	32.41	-	-	P	V
			715.79	30.56	-15.44	46	32.58	26.67	3.73	32.42	100	0	P	V
														V
														V
													V	
													V	
													V	
													V	
Remark	1. No other spurious found. 2. All results are PASS against limit line.													



**Note symbol**

*	<b>Fundamental Frequency</b> which can be ignored. However, the level of any unwanted emissions shall not exceed the level of the fundamental frequency.
!	Test result is <b>over limit</b> line.
P/A	<b>Peak</b> or <b>Average</b>
H/V	<b>Horizontal</b> or <b>Vertical</b>



A calculation example for radiated spurious emission is shown as below:

WIFI	Note	Frequency	Level	Over	Limit	Read	Antenna	Path	Preamp	Ant	Table	Peak	Pol.
Ant.				Limit	Line	Level	Factor	Loss	Factor	Pos	Pos	Avg.	
4+3		( MHz )	( dBμV/m )	( dB )	( dBμV/m )	( dBμV )	( dB/m )	( dB )	( dB )	( cm )	( deg )	( P/A )	( H/V )
802.11b		2390	55.45	-18.55	74	54.51	32.22	4.58	35.86	103	308	P	H
CH 01													
2412MHz		2390	43.54	-10.46	54	42.6	32.22	4.58	35.86	103	308	A	H

1. Path Loss(dB) = Cable loss(dB) + Filter loss(dB) + Attenuator loss(dB)
2. Level(dBμV/m) =  
Antenna Factor(dB/m) + Path Loss(dB) + Read Level(dBμV) - Preamp Factor(dB)
3. Over Limit(dB) = Level(dBμV/m) – Limit Line(dBμV/m)

**For Peak Limit @ 2390MHz:**

1. Level(dBμV/m)  
= Antenna Factor(dB/m) + Path Loss(dB) + Read Level(dBμV) - Preamp Factor(dB)  
= 32.22(dB/m) + 4.58(dB) + 54.51(dBμV) – 35.86 (dB)  
= 55.45 (dBμV/m)
2. Over Limit(dB)  
= Level(dBμV/m) – Limit Line(dBμV/m)  
= 55.45(dBμV/m) – 74(dBμV/m)  
= -18.55(dB)

**For Average Limit @ 2390MHz:**

1. Level(dBμV/m)  
= Antenna Factor(dB/m) + Path Loss(dB) + Read Level(dBμV) - Preamp Factor(dB)  
= 32.22(dB/m) + 4.58(dB) + 42.6(dBμV) – 35.86 (dB)  
= 43.54 (dBμV/m)
2. Over Limit(dB)  
= Level(dBμV/m) – Limit Line(dBμV/m)  
= 43.54(dBμV/m) – 54(dBμV/m)  
= -10.46(dB)

**Both peak and average measured complies with the limit line, so test result is “PASS”.**



## Appendix C. Radiated Spurious Emission Plots

Test Engineer :	Leo Lee, Mancy Chou and Bigshow Wang	Temperature :	22.1~23.1°C
		Relative Humidity :	52~61%

### Note symbol

-L	Low channel location
-R	High channel location



<Open Mode>

2.4GHz 2400~2483.5MHz  
WIFI 802.11b (Band Edge @ 3m)

WIFI	2.4GHz 2400~2483.5MHz Band Edge @ 3m	
ANT	802.11b CH11 2462MHz	
4+3	Horizontal	Fundamental
Peak	<p>Site : 03CH15-HY Condition : PEAK_BE_74 3m 91200_15_1620 HORIZONTAL Detector : Peak Project : 051232-02</p>	<p>Site : 03CH15-HY Condition : PEAK_74 3m 91200_15_1620 HORIZONTAL Detector : Peak Project : 051232-02</p>
Avg.	<p>Site : 03CH15-HY Condition : AVG_BE_54 3m 91200_15_1620 HORIZONTAL Detector : Peak Project : 051232-02</p>	<p>Site : 03CH15-HY Condition : AVG_54 3m 91200_15_1620 HORIZONTAL Detector : Peak Project : 051232-02</p>

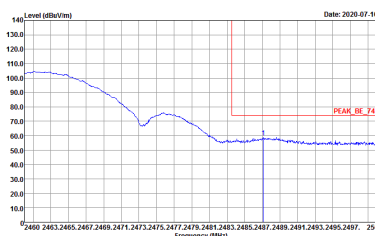
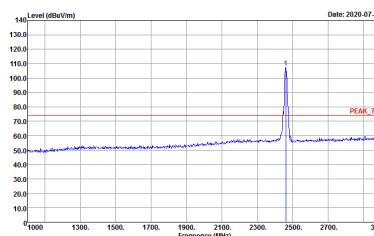
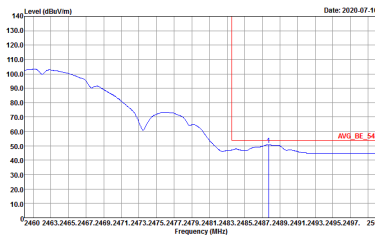
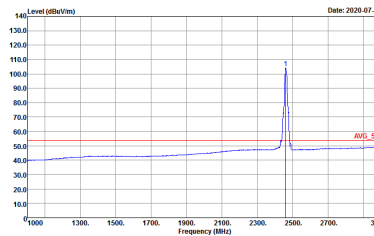

WIFI	2.4GHz 2400~2483.5MHz Band Edge @ 3m	
ANT	802.11b CH11 2462MHz	
4+3	Vertical	Fundamental
<p><b>Peak</b></p>	 <p>Site : 03CH15-HY            Condition : PEAK_BE_74 3m 91200_15_1620 VERTICAL            Detector : Peak            Project : 051232-02</p>	 <p>Site : 03CH15-HY            Condition : PEAK_74 3m 91200_15_1620 VERTICAL            Detector : Peak            Project : 051232-02</p>
<p><b>Avg.</b></p>	 <p>Site : 03CH15-HY            Condition : AVG_BE_54 3m 91200_15_1620 VERTICAL            Detector : Peak            Project : 051232-02</p>	 <p>Site : 03CH15-HY            Condition : AVG_54 3m 91200_15_1620 VERTICAL            Detector : Peak            Project : 051232-02</p>

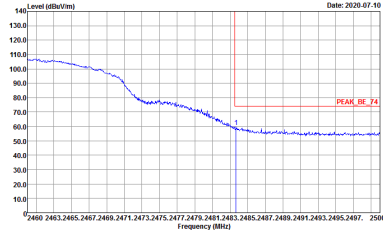
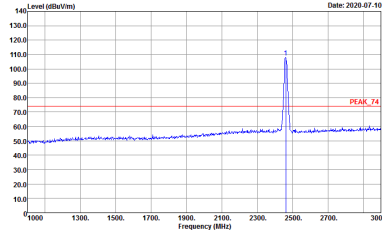
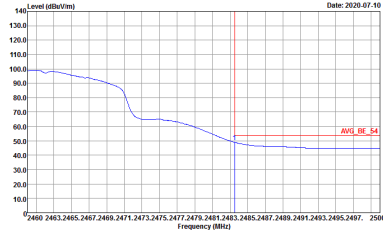
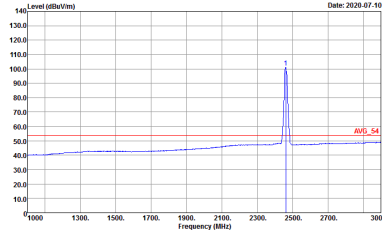

2.4GHz 2400~2483.5MHz  
 WIFI 802.11n HT20 (Band Edge @ 3m)

WIFI	2.4GHz 2400~2483.5MHz Band Edge @ 3m	
ANT	802.11n HT20 CH11 2462MHz	
4+3	Horizontal	Fundamental
Peak	 <p>Site : 03CH15-HY            Condition : PEAK_BE_74 3m 91200_15_1620 HORIZONTAL            Detector : Peak            Project : 051232-02</p>	 <p>Site : 03CH15-HY            Condition : PEAK_74 3m 91200_15_1620 HORIZONTAL            Detector : Peak            Project : 051232-02</p>
	 <p>Site : 03CH15-HY            Condition : AVG_BE_54 3m 91200_15_1620 HORIZONTAL            Detector : Peak            Project : 051232-02</p>	 <p>Site : 03CH15-HY            Condition : AVG_54 3m 91200_15_1620 HORIZONTAL            Detector : Peak            Project : 051232-02</p>
Avg.		

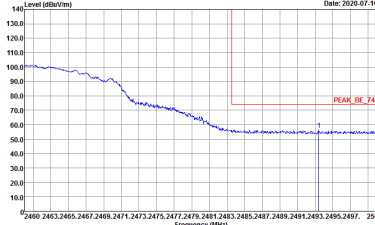
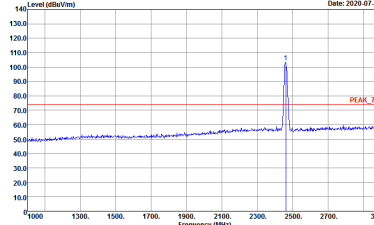
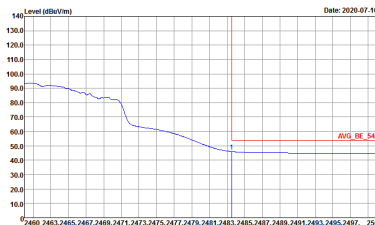
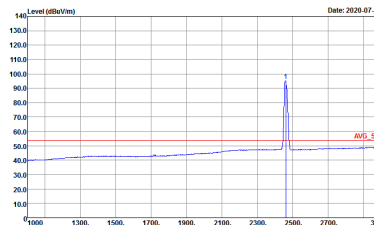

WIFI	2.4GHz 2400~2483.5MHz Fundamental @ 3m	
ANT	802.11n HT20 CH11 2462MHz	
4+3	Vertical	Fundamental
Peak	 <p>Site : 03CH15-HY            Condition : PEAK_BE_74 3m 91200_15_1620 VERTICAL            Detector : Peak            Project : 051232-02</p>	 <p>Site : 03CH15-HY            Condition : PEAK_74 3m 91200_15_1620 VERTICAL            Detector : Peak            Project : 051232-02</p>
Avg.	 <p>Site : 03CH15-HY            Condition : AVG_BE_54 3m 91200_15_1620 VERTICAL            Detector : Peak            Project : 051232-02</p>	 <p>Site : 03CH15-HY            Condition : AVG_54 3m 91200_15_1620 VERTICAL            Detector : Peak            Project : 051232-02</p>

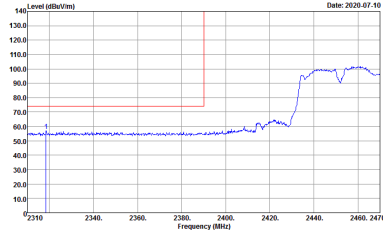
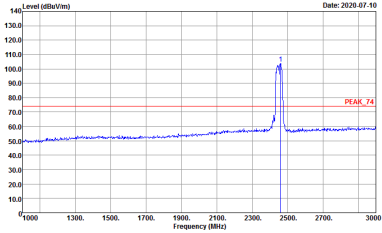
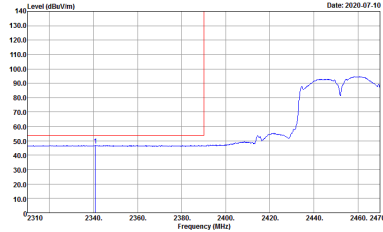
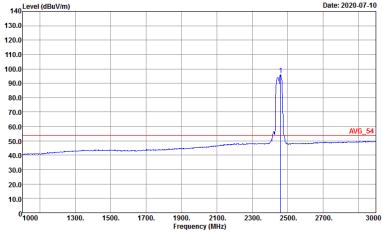

2.4GHz 2400~2483.5MHz  
 WIFI 802.11n HT40 (Band Edge @ 3m)

WIFI	2.4GHz 2400~2483.5MHz Band Edge @ 3m	
ANT	802.11n HT40 CH09 2452MHz - L	
4+3	Horizontal	Fundamental
Peak	 <p>Site : 03CH15-HY            Condition : PEAK_BE_74 3m 91200_15_1620 HORIZONTAL            Detector : Peak            Project : 051232-02</p>	 <p>Site : 03CH15-HY            Condition : PEAK_74 3m 91200_15_1620 HORIZONTAL            Detector : Peak            Project : 051232-02</p>
Avg.	 <p>Site : 03CH15-HY            Condition : AVG_BE_54 3m 91200_15_1620 HORIZONTAL            Detector : Peak            Project : 051232-02</p>	 <p>Site : 03CH15-HY            Condition : AVG_54 3m 91200_15_1620 HORIZONTAL            Detector : Peak            Project : 051232-02</p>

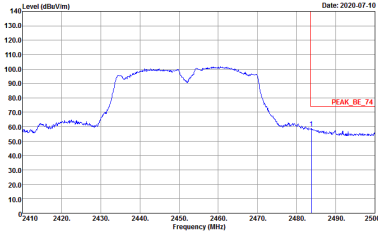
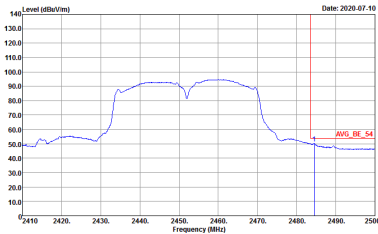

WIFI	2.4GHz 2400~2483.5MHz Band Edge @ 3m	
ANT	802.11n HT40 CH09 2452MHz - R	
4+3	Horizontal	Fundamental
<p><b>Peak</b></p>	 <p>Date: 2020-07-10</p> <p>Site : 03CH15-HY            Condition : PEAK_BE_74 3m 91200_15_1620 HORIZONTAL            RBW:1000.000KHz VBW:3000.000KHz SWF:Auto            Detector : Peak            Project : 051232-02</p>	<p>Left blank</p>
<p><b>Avg.</b></p>	 <p>Date: 2020-07-10</p> <p>Site : 03CH15-HY            Condition : AVG_BE_54 3m 91200_15_1620 HORIZONTAL            RBW:1000.000KHz VBW:3.000KHz SWF:Auto            Detector : Peak            Project : 051232-02</p>	<p>Left blank</p>

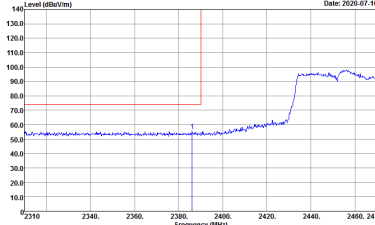
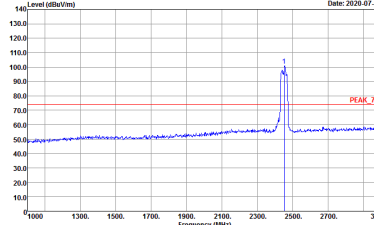
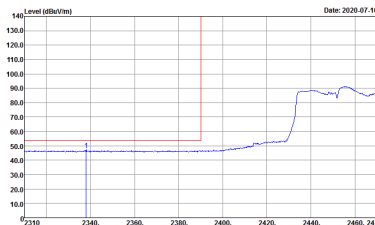
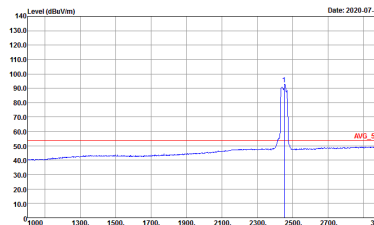

WIFI	2.4GHz 2400~2483.5MHz Band Edge @ 3m	
ANT	802.11n HT40 CH09 2452MHz - L	
4+3	Vertical	Fundamental
<p><b>Peak</b></p>	 <p>Site : 03CH15-HY            Condition : PEAK_8E_74 3m 91200_15_1620 VERTICAL            RBW:1000.000KHz VBW:3000.000KHz SWT:Auto            Detector : Peak            Project : 051232-02</p>	 <p>Site : 03CH15-HY            Condition : PEAK_74 3m 91200_15_1620 VERTICAL            RBW:1000.000KHz VBW:3000.000KHz SWT:Auto            Detector : Peak            Project : 051232-02</p>
<p><b>Avg.</b></p>	 <p>Site : 03CH15-HY            Condition : AVG_8E_54 3m 91200_15_1620 VERTICAL            RBW:1000.000KHz VBW:3.000KHz SWT:Auto            Detector : Peak            Project : 051232-02</p>	 <p>Site : 03CH15-HY            Condition : AVG_54 3m 91200_15_1620 VERTICAL            RBW:1000.000KHz VBW:3.000KHz SWT:Auto            Detector : Peak            Project : 051232-02</p>

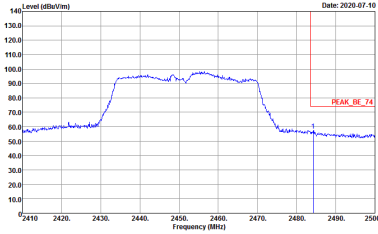
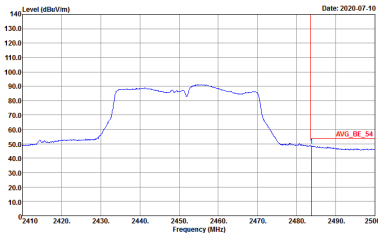

WIFI	2.4GHz 2400~2483.5MHz Band Edge @ 3m	
ANT	802.11n HT40 CH09 2452MHz - R	
4+3	Vertical	Fundamental
<p><b>Peak</b></p>	 <p>Date: 2020-07-10</p> <p>Site : 03CH15-HY            Condition : PEAK_BE_74 3m 91200_15_1620 VERTICAL            RBW:1000.000kHz VBW:3000.000kHz SWF:Auto            Detector : Peak            Project : 051232-02</p>	<p>Left blank</p>
<p><b>Avg.</b></p>	 <p>Date: 2020-07-10</p> <p>Site : 03CH15-HY            Condition : AVG_BE_54 3m 91200_15_1620 VERTICAL            RBW:1000.000kHz VBW:3.000kHz SWF:Auto            Detector : Peak            Project : 051232-02</p>	<p>Left blank</p>



2.4GHz 2400~2483.5MHz  
WIFI 802.11b (Harmonic @ 3m)

WIFI	2.4GHz 2400~2483.5MHz Harmonic @ 3m	
ANT	802.11b CH11 2462MHz	
4+3	Horizontal	Vertical
Peak Avg.	<p>Site : 03CH15-1FY Condition : PEAK_74 3m 91200_15_1620 HORIZONTAL Detector : Peak Project : 051232-02</p>	<p>Site : 03CH15-1FY Condition : PEAK_74 3m 91200_15_1620 VERTICAL Detector : Peak Project : 051232-02</p>



2.4GHz 2400~2483.5MHz
WIFI 802.11n HT20 (Harmonic @ 3m)

Table with 4 columns: WIFI, ANT, 4+3, and two measurement graphs (Horizontal and Vertical). Includes peak and average level data for 2.4GHz harmonics.



2.4GHz 2400~2483.5MHz
WIFI 802.11n HT40 (Harmonic @ 3m)

Table with 2 columns: Horizontal and Vertical. Each column contains a graph of Level (dBuV/m) vs Frequency (MHz) and associated test parameters like Site, Condition, Detector, and Project.

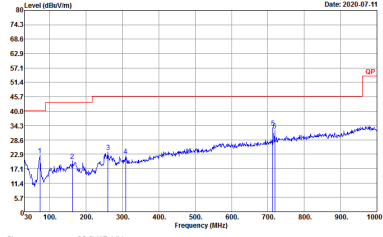
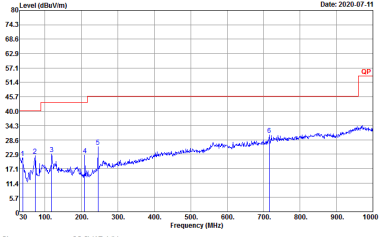

Emission below 1GHz  
2.4GHz WIFI 802.11b (LF)

WIFI	2.4GHz 2400~2483.5MHz	
ANT	802.11b LF	
4+3	Horizontal	Vertical
QP / Peak	 <p>Site : 03CH15-FY Condition : QP 3m BTL0G_15_41912 HORIZONTAL Detector : Peak Project : 051232-02</p>	 <p>Site : 03CH15-FY Condition : QP 3m BTL0G_15_41912 VERTICAL Detector : Peak Project : 051232-02</p>



### Appendix D. Duty Cycle Plots

Antenna	Band	Duty Cycle(%)	T(us)	1/T(kHz)	VBW Setting	Duty Factor(dB)
4+3	802.11b for Ant. 4	99.23	-	-	10Hz	0.03
4+3	802.11b for Ant. 3	99.19	-	-	10Hz	0.04
4+3	2.4GHz 802.11n HT20 for Ant. 4	97.92	1885	0.53	1kHz	0.09
4+3	2.4GHz 802.11n HT20 for Ant. 3	98.18	-	-	10Hz	0.08
4+3	2.4GHz 802.11n HT40 for Ant. 4	94.36	925	1.08	3kHz	0.25
4+3	2.4GHz 802.11n HT40 for Ant. 3	94.90	930	1.08	3kHz	0.23



MIMO <Ant. 4>

802.11b

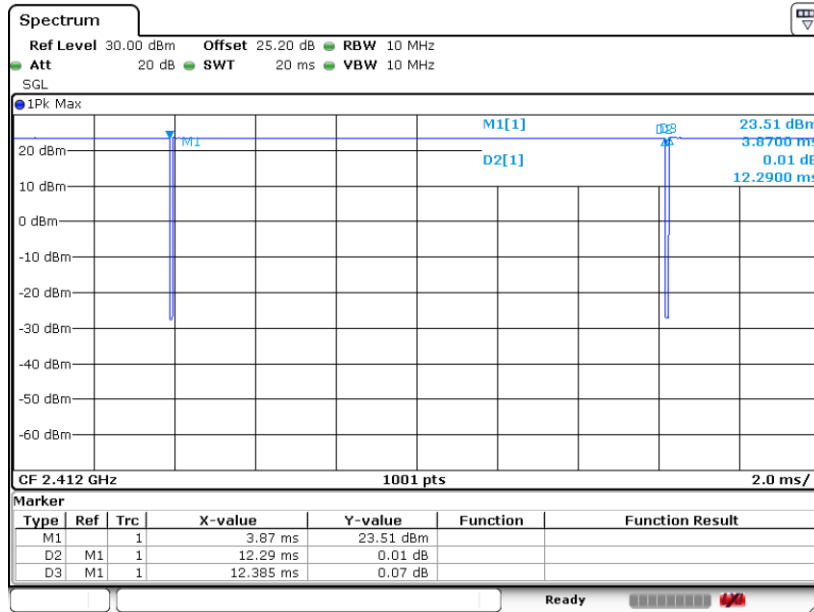

Date: 7.JUL.2020 21:26:55

802.11n HT20

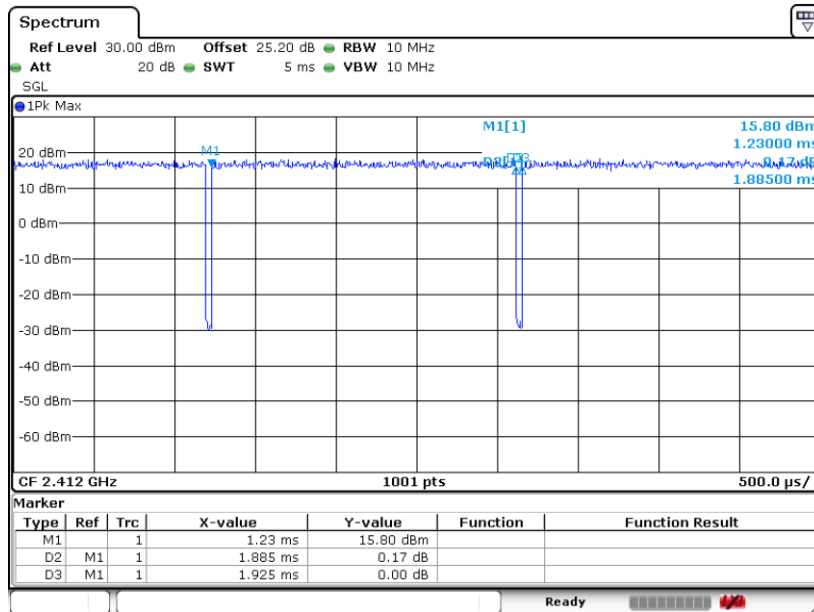

Date: 9.JUL.2020 21:20:21



802.11n HT40

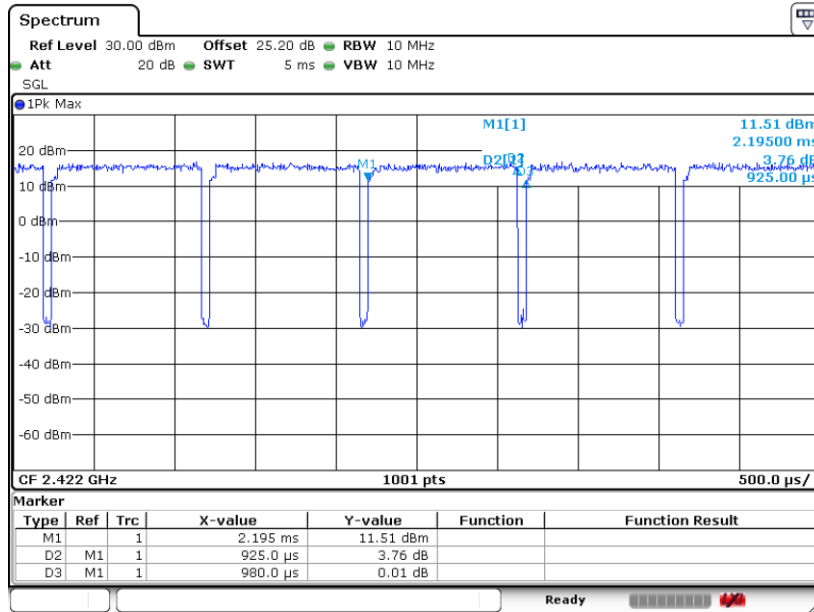

Date: 9.JUL.2020 21:54:25

MIMO <Ant. 3>

802.11b

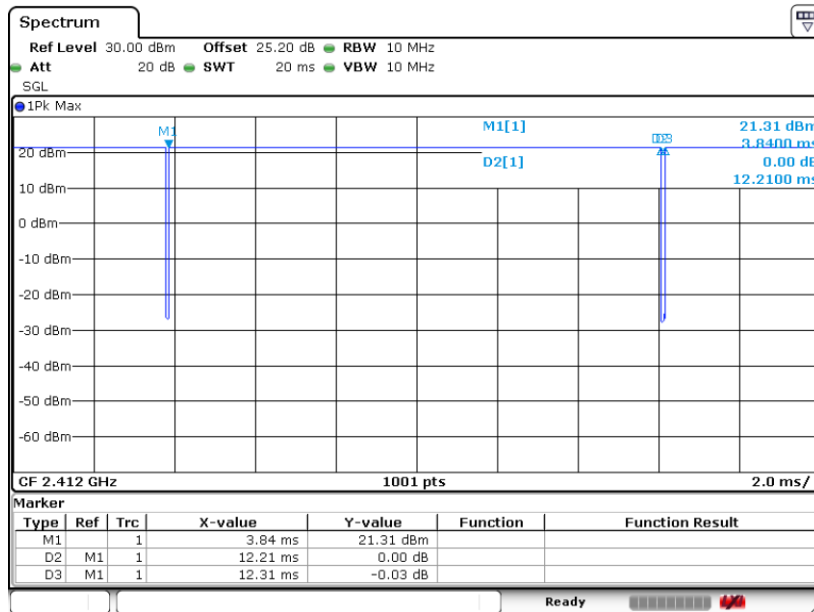

Date: 7.JUL.2020 21:29:00



802.11n HT20

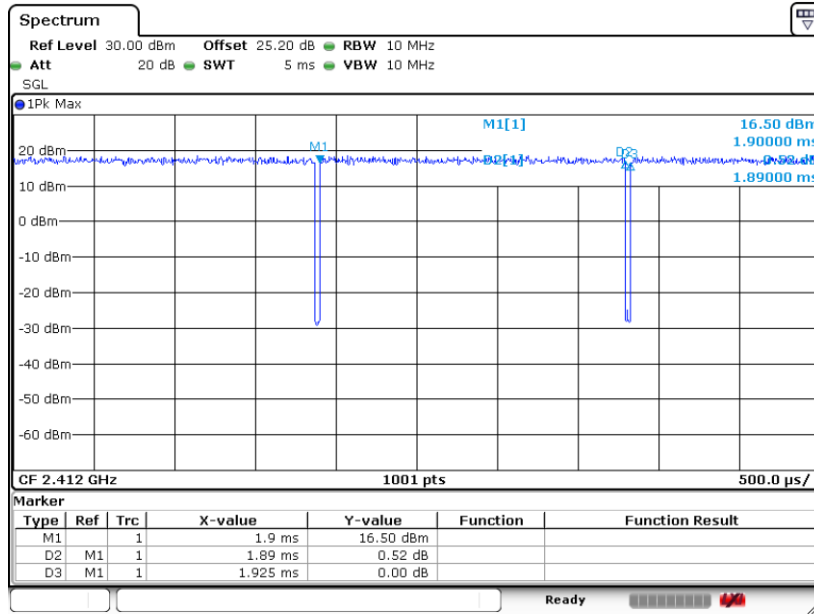

Date: 9.JUL.2020 21:21:43

802.11n HT40

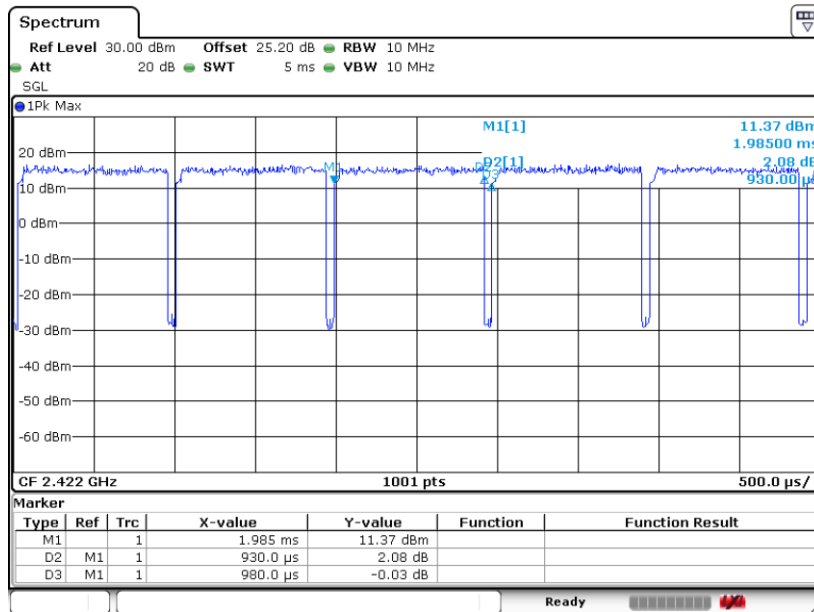

Date: 9.JUL.2020 21:55:21

—THE END—