



# FCC RADIO TEST REPORT

**FCC ID** : IHDT56ZB1  
**Equipment** : Mobile Cellular Phone  
**Brand Name** : Motorola  
**Model Name** : XT2071-2, XT2071-3, XT2071-5  
**Applicant** : Motorola Mobility, LLC  
222 W Merchandise Mart Plaza, Suite  
1800, Chicago, IL 60654, United States  
**Manufacturer** : Motorola Mobility, LLC  
222 W Merchandise Mart Plaza, Suite  
1800, Chicago, IL 60654, United States  
**Standard** : FCC Part 15 Subpart E §15.407

The product was received on May 22, 2020 and testing was started from Jul. 10, 2020 and completed on Jul. 24, 2020. We, SPORTON INTERNATIONAL INC., EMC & Wireless Communications Laboratory, would like to declare that the tested sample has been evaluated in accordance with the test procedures and has been in compliance with the applicable technical standards.

The test results in this variant report apply exclusively to the tested model / sample. Without written approval of SPORTON INTERNATIONAL INC. EMC & Wireless Communications Laboratory, the test report shall not be reproduced except in full.

*Louis Wu*

Approved by: Louis Wu

**SPORTON INTERNATIONAL INC. EMC & Wireless Communications Laboratory**  
No. 52, Huaya 1st Rd., Guishan Dist., Taoyuan City, Taiwan (R.O.C.)



# Table of Contents

**History of this test report..... 3**

**Summary of Test Result..... 4**

**1 General Description ..... 5**

    1.1 Product Feature of Equipment Under Test..... 5

    1.2 Product Specification of Equipment Under Test..... 7

    1.3 Modification of EUT ..... 7

    1.4 Testing Location ..... 8

    1.5 Applicable Standards..... 8

**2 Test Configuration of Equipment Under Test ..... 9**

    2.1 Carrier Frequency and Channel ..... 9

    2.2 Test Mode..... 9

    2.3 Connection Diagram of Test System..... 10

    2.4 EUT Operation Test Setup ..... 10

**3 Test Result ..... 11**

    3.1 Maximum Conducted Output Power Measurement ..... 11

    3.2 Unwanted Emissions Measurement ..... 12

    3.3 Antenna Requirements..... 17

**4 List of Measuring Equipment..... 18**

**5 Uncertainty of Evaluation..... 19**

**Appendix A. Conducted Test Results**

**Appendix B. Radiated Spurious Emission**

**Appendix C. Radiated Spurious Emission Plots**

**Appendix D. Duty Cycle Plots**



### History of this test report

Report No.	Version	Description	Issued Date
FR051232-02F	01	Initial issue of report	Jul. 30, 2020

## Summary of Test Result

Report Clause	Ref Std. Clause	Test Items	Result (PASS/FAIL)	Remark
-	15.403 (i)	6dB & 26dB Bandwidth	Not Required	-
-	2.1049	99% Occupied Bandwidth	Not Required	-
3.1	15.407 (a)	Maximum Conducted Output Power	Pass	-
-	15.407 (a)	Power Spectral Density	Not Required	-
3.2	15.407(b)	Unwanted Emissions	Pass	Under limit 13.09 dB at 925.310 MHz
-	15.207	AC Conducted Emission	Not Required	-
-	15.407 (c)	Automatically Discontinue Transmission	Not Required	-
3.3	15.203 & 15.407 (a)	Antenna Requirement	Pass	-

**Note:**

1. Not required means after assessing, test items are not necessary to carry out.
2. This is a variant report which can be referred Product Equality Declaration. All the test cases were performed on original report which can be referred to Sporton Report Number FR051232F. Based on the original report, only worst case was verified.

**Declaration of Conformity:**

The test results with all measurement uncertainty excluded are presented in accordance with the regulation limits or requirements declared by manufacturers.

**Comments and Explanations:**

The declared of product specification for EUT presented in the report are provided by the manufacturer, and the manufacturer takes all the responsibilities for the accuracy of product specification.

**Reviewed by: Wii Chang**

**Report Producer: Yimin Ho**



# 1 General Description

## 1.1 Product Feature of Equipment Under Test

Product Feature	
Equipment	Mobile Cellular Phone
Brand Name	Motorola
Model Name	XT2071-2, XT2071-3, XT2071-5
FCC ID	IHDT56ZB1
IMEI Code	<b>Conducted :</b> IMEI 1: 353590110016410 IMEI 2: 353590110016428 <b>Radiation :</b> IMEI 1: 353590110017152 IMEI 2: 353590110017160
EUT supports Radios application	CDMA/EV-DO/GSM/EGPRS/WCDMA/HSPA/LTE/5G NR/ GNSS/NFC WLAN 11a/b/g/n HT20/HT40 WLAN 11ac VHT20/VHT40/VHT80 Bluetooth BR/EDR/LE
HW Version	DVT2
EUT Stage	Identical Prototype

**Remark:** The above EUT's information was declared by manufacturer.



<b>Accessory List</b>	
<b>AC Adapter 1 (US)</b>	Brand Name : Motorola
	Model Name : SC-51
	Manufacturer : Chenyang
<b>AC Adapter 1 (EU)</b>	Brand Name : Motorola
	Model Name : SC-52
	Manufacturer : Chenyang
<b>AC Adapter 1 (UK)</b>	Brand Name : Motorola
	Model Name : SC-53UK
	Manufacturer : Chenyang
<b>AC Adapter 1 (AR)</b>	Brand Name : Motorola
	Model Name : SC-56
	Manufacturer : Chenyang
<b>AC Adapter 1 (AU)</b>	Brand Name : Motorola
	Model Name : SC-55AU
	Manufacturer : Chenyang
<b>AC Adapter 2 (US)</b>	Brand Name : Motorola
	Model Name : SC-51
	Manufacturer : Acbel
<b>AC Adapter 2 (EU)</b>	Brand Name : Motorola
	Model Name : SC-52
	Manufacturer : Acbel
<b>AC Adapter 2 (AR)</b>	Brand Name : Motorola
	Model Name : SC-56
	Manufacturer : Acbel
<b>AC Adapter 3 (IN)</b>	Brand Name : Motorola
	Model Name : SC-54
	Manufacturer : Salom
<b>Battery 1</b>	Brand Name : Motorola
	Model Name : LS30
	Manufacturer : ATL
<b>Battery 2</b>	Brand Name : Motorola
	Model Name : LS40
	Manufacturer : ATL
<b>Standard 3.5mm Headset 1</b>	Brand Name : Motorola
	Model Name : SH38C37773
	Manufacturer : Lianyun
<b>Standard 3.5mm Headset 2</b>	Brand Name : Motorola
	Model Name : SH38C44959
	Manufacturer : Lianyun
<b>USB-C to 3.5mm headset adaptor 1</b>	Brand Name : Motorola
	Model Name : SC18C27844
<b>USB-C to 3.5mm headset adaptor 2</b>	Brand Name : Motorola
	Model Name : SC18C27845
<b>USB Cable 1</b>	Brand Name : Motorola
	Model Name : SC18C24367
	Manufacturer : Saibao
<b>USB Cable 2</b>	Brand Name : Motorola
	Model Name : SC18C24368
	Manufacturer : Luxshare

## 1.2 Product Specification of Equipment Under Test

Standards-related Product Specification										
Tx/Rx Frequency Range	5745 MHz ~ 5825 MHz									
Maximum Output Power to Antenna <CDD Modes>	<b>&lt;5745 MHz ~ 5825 MHz&gt;</b> <b>MIMO &lt;Ant. 4 + 3&gt;</b> 802.11a : 23.08 dBm / 0.2032 W 802.11n HT20 : 22.88 dBm / 0.1941 W 802.11n HT40 : 22.52 dBm / 0.1786 W 802.11ac VHT20: 22.61 dBm / 0.1824 W 802.11ac VHT40: 22.17 dBm / 0.1648 W 802.11ac VHT80: 21.91 dBm / 0.1552 W									
Maximum Output Power to Antenna <TXBF Modes>	<b>&lt;MIMO &lt;Ant. 4 + 3&gt;</b> 802.11ac VHT20: 19.67 dBm / 0.0927 W 802.11ac VHT40: 19.72 dBm / 0.0938 W 802.11ac VHT80: 19.47 dBm / 0.0885 W									
Type of Modulation	802.11a/n : OFDM (BPSK / QPSK / 16QAM / 64QAM) 802.11ac : OFDM (BPSK / QPSK / 16QAM / 64QAM / 256QAM)									
Antenna Type / Gain	<b>&lt;Ant. 4&gt;</b> : Slot Antenna Type with gain 0.2 dBi <b>&lt;Ant. 3&gt;</b> : IFA Antenna Type with gain 1.0 dBi									
Antenna Function Description	<table border="1"> <thead> <tr> <th></th> <th>Ant. 4</th> <th>Ant. 3</th> </tr> </thead> <tbody> <tr> <td>802.11 a/n/ac MIMO</td> <td>V</td> <td>V</td> </tr> <tr> <td>802.11 ac TXBF</td> <td>V</td> <td>V</td> </tr> </tbody> </table>		Ant. 4	Ant. 3	802.11 a/n/ac MIMO	V	V	802.11 ac TXBF	V	V
	Ant. 4	Ant. 3								
802.11 a/n/ac MIMO	V	V								
802.11 ac TXBF	V	V								

**Note:** MIMO Ant. 4+3 is a calculated result from sum of the power MIMO Ant. 4 and MIMO Ant. 3

## 1.3 Modification of EUT

No modifications are made to the EUT during all test items.



### 1.4 Testing Location

<b>Test Site</b>	SPORTON INTERNATIONAL INC. EMC & Wireless Communications Laboratory
<b>Test Site Location</b>	No.52, Huaya 1st Rd., Guishan Dist., Taoyuan City, Taiwan (R.O.C.) TEL: +886-3-327-3456 FAX: +886-3-328-4978
<b>Test Site No.</b>	<b>Sporton Site No.</b>
	TH05-HY

**Note:** The test site complies with ANSI C63.4 2014 requirement.

<b>Test Site</b>	SPORTON INTERNATIONAL INC. EMC & Wireless Communications Laboratory
<b>Test Site Location</b>	No.58, Aly. 75, Ln. 564, Wenhua 3rd, Rd., Guishan Dist., Taoyuan City, Taiwan (R.O.C.) TEL: +886-3-327-0868 FAX: +886-3-327-0855
<b>Test Site No.</b>	<b>Sporton Site No.</b>
	03CH15-HY

**Note:** The test site complies with ANSI C63.4 2014 requirement.

FCC designation No.: TW1190 and TW0007

### 1.5 Applicable Standards

According to the specifications of the manufacturer, the EUT must comply with the requirements of the following standards:

- ♦ FCC Part 15 Subpart E
- ♦ FCC KDB 789033 D02 General UNII Test Procedures New Rules v02r01.
- ♦ FCC KDB 414788 D01 Radiated Test Site v01r01.
- ♦ FCC KDB 662911 D01 Multiple Transmitter Output v02r01.
- ♦ ANSI C63.10-2013

**Remark:**

1. All test items were verified and recorded according to the standards and without any deviation during the test.
2. The TAF code is not including all the FCC KDB listed without accreditation.
3. This EUT has also been tested and complied with the requirements of FCC Part 15, Subpart B, recorded in a separate test report.



## 2 Test Configuration of Equipment Under Test

The EUT has been associated with peripherals and configuration operated in a manner tended to maximize its emission characteristics in a typical application. Frequency range investigated: radiation emission (9 kHz to the 10th harmonic of the highest fundamental frequency or to 40 GHz, whichever is lower). For radiated measurement, pre-scanned in three orthogonal panels, X, Y, Z and Accessory (Earphone or Adapter). The worst cases (Open Mode: X plane with Adapter for CDD Mode) were recorded in this report.

### 2.1 Carrier Frequency and Channel

Frequency Band	Channel	Freq. (MHz)	Channel	Freq. (MHz)
5725-5850 MHz Band 4 (U-NII-3)	149	5745	157	5785
	151*	5755	159*	5795
	153	5765	161	5805
	155 <sup>#</sup>	5775	165	5825

**Note:**

1. The above Frequency and Channel in "\*" were 802.11n HT40 and 802.11ac VHT40.
2. The above Frequency and Channel in "<sup>#</sup>" were 802.11ac VHT80.

### 2.2 Test Mode

Final test modes are considering the modulation and worse data rates as below table.

**CDD Mode**

Modulation	Data Rate
802.11a	6 Mbps
802.11n HT20	MCS0
802.11n HT40	MCS0
802.11ac VHT20	MCS0
802.11ac VHT40	MCS0
802.11ac VHT80	MCS0

**TXBF Mode**

Modulation	Data Rate
802.11ac VHT20	MCS0
802.11ac VHT40	MCS0
802.11ac VHT80	MCS0

Ch. #		Band IV : 5725-5850 MHz
		802.11ac VHT80
L	Low	-
M	Middle	155
H	High	-

**Remark:**

1. For radiation spurious emission, the final modulation and the worst data rate was reference the max RF conducted power.
2. For Radiated Test Cases, the tests were performed with AC Adapter 1 (US) and USB Cable 1.

### 2.3 Connection Diagram of Test System

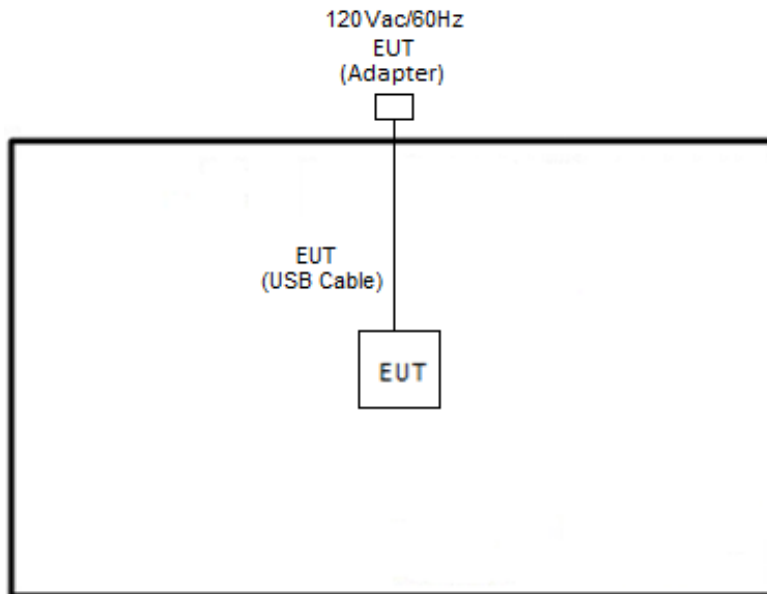

### 2.4 EUT Operation Test Setup

The RF test items, utility “QRCT v4.0.00156.0” was installed in Notebook which was programmed in order to make the EUT get into the engineering modes to provide channel selection, power level, data rate and the application type and for continuous transmitting signals.

### 3 Test Result

#### 3.1 Maximum Conducted Output Power Measurement

##### 3.1.1 Limit of Maximum Conducted Output Power

For the band 5.725–5.85 GHz, the maximum conducted output power over the frequency band of operation shall not exceed 1 W.

If transmitting antennas of directional gain greater than 6 dBi are used, the peak output power shall be reduced by the amount in dB that the directional gain of the antenna exceeds 6 dBi.

##### 3.1.2 Measuring Instruments

See list of measuring equipment of this test report.

##### 3.1.3 Test Procedures

The testing follows Method PM-G of FCC KDB 789033 D02 General UNII Test Procedures New Rules v02r01.

Method PM-G (Measurement using a gated RF average power meter):

1. Measurement is performed using a wideband RF power meter.
2. The EUT is configured to transmit at its maximum power control level.
3. Measure the average power of the transmitter
4. Since the measurement is made only during the ON time of the transmitter, no duty cycle correction factor is required.

##### 3.1.4 Test Setup

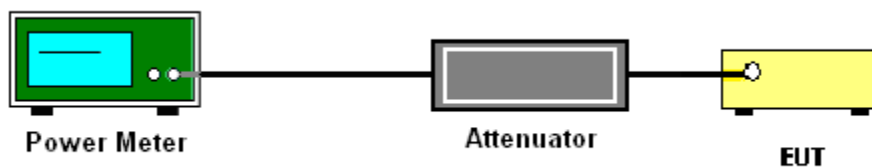

##### 3.1.5 Test Result of Maximum Conducted Output Power

Please refer to Appendix A.



### 3.2 Unwanted Emissions Measurement

This section is to measure unwanted emissions through radiated measurement for band edge spurious emissions and out of band emissions measurement.

#### 3.2.1 Limit of Unwanted Emissions

- (1) For transmitters operating in the 5.725-5.85 GHz band:  
 15.407(b)(4)(i) All emissions shall be limited to a level of -27 dBm/MHz at 75 MHz or more above or below the band edge increasing linearly to 10 dBm/MHz at 25 MHz above or below the band edge, and from 25 MHz above or below the band edge increasing linearly to a level of 15.6 dBm/MHz at 5 MHz above or below the band edge, and from 5 MHz above or below the band edge increasing linearly to a level of 27 dBm/MHz at the band edge.
- (2) Unwanted spurious emissions fallen in restricted bands shall comply with the general field strength limits as below table,

Frequency (MHz)	Field Strength (microvolts/meter)	Measurement Distance (meters)
0.009 – 0.490	2400/F(kHz)	300
0.490 – 1.705	24000/F(kHz)	30
1.705 – 30.0	30	30
30 – 88	100	3
88 – 216	150	3
216 - 960	200	3
Above 960	500	3

**Note:** The following formula is used to convert the EIRP to field strength.

$$E = \frac{1000000\sqrt{30P}}{3} \mu\text{V/m, where P is the eirp (Watts)}$$



EIRP (dBm)	Field Strength at 3m (dBμV/m)
- 27	68.3

(3) KDB789033 D02 v02r01 G)2)c)

- (i) Sections 15.407(b)(1-3) specifies the unwanted emissions limit for the U-NII-1 and U-NII-2 bands. As specified, emissions above 1000 MHz that are outside of the restricted bands are subject to a peak emission limit of -27 dBm/MHz.
- (ii) Section 15.407(b)(4) specifies the unwanted emissions limit for the U-NII-3 band. A band emissions mask is specified in Section 15.407(b)(4)(i). The emission limits are based on the use of a peak detector.

### 3.2.2 Measuring Instruments

See list of measuring equipment of this test report.

### 3.2.3 Test Procedures

1. The testing follows FCC KDB 789033 D02 General UNII Test Procedures New Rules v02r01. Section G) Unwanted emissions measurement.

(1) Procedure for Unwanted Emissions Measurements Below 1000MHz

- RBW = 120 kHz
- VBW = 300 kHz
- Detector = Peak
- Trace mode = max hold

(2) Procedure for Peak Unwanted Emissions Measurements Above 1000 MHz

- RBW = 1 MHz
- VBW ≥ 3 MHz
- Detector = Peak
- Sweep time = auto
- Trace mode = max hold

(3) Procedures for Average Unwanted Emissions Measurements Above 1000MHz

- RBW = 1 MHz
- VBW = 10 Hz, when duty cycle is no less than 98 percent.
- VBW ≥ 1/T, when duty cycle is less than 98 percent where T is the minimum transmission duration over which the transmitter is on and is transmitting at its maximum power control level for the tested mode of operation.

2. The EUT was placed on a turntable with 0.8 meter for frequency below 1GHz and 1.5 meter for frequency above 1GHz respectively above ground.
3. The EUT was set 3 meters from the interference receiving antenna which was mounted on the top of a variable height antenna tower.
4. The antenna is a broadband antenna and its height is adjusted between one meter and four meters above ground to find the maximum value of the field strength for both horizontal polarization and vertical polarization of the antenna.
5. For each suspected emission, the EUT was arranged to its worst case and then adjust the antenna tower (from 1 m to 4 m) and turntable (from 0 degree to 360 degrees) to find the maximum reading.
6. For testing below 1GHz, if the emission level of the EUT in peak mode was 3 dB lower than the limit specified, then peak values of EUT will be reported, otherwise, the emissions will be repeated one by one using the CISPR quasi-peak method and reported.
7. For testing above 1GHz, the emission level of the EUT in peak mode was 20dB lower than average limit (that means the emission level in average mode also complies with the limit in average mode), then peak values of EUT will be reported, otherwise, the emissions will be measured in average mode again and reported.

### 3.2.4 Test Setup

For radiated emissions below 30MHz

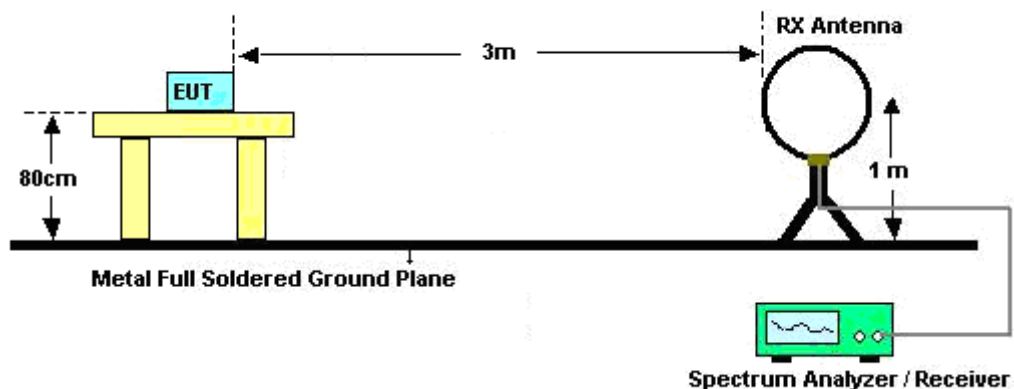

For radiated emissions from 30MHz to 1GHz

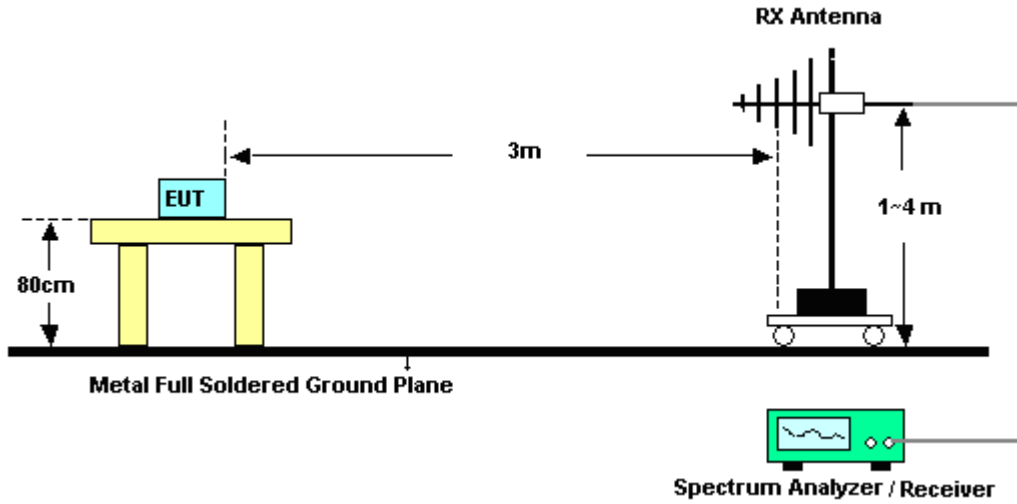

For radiated emissions above 1GHz

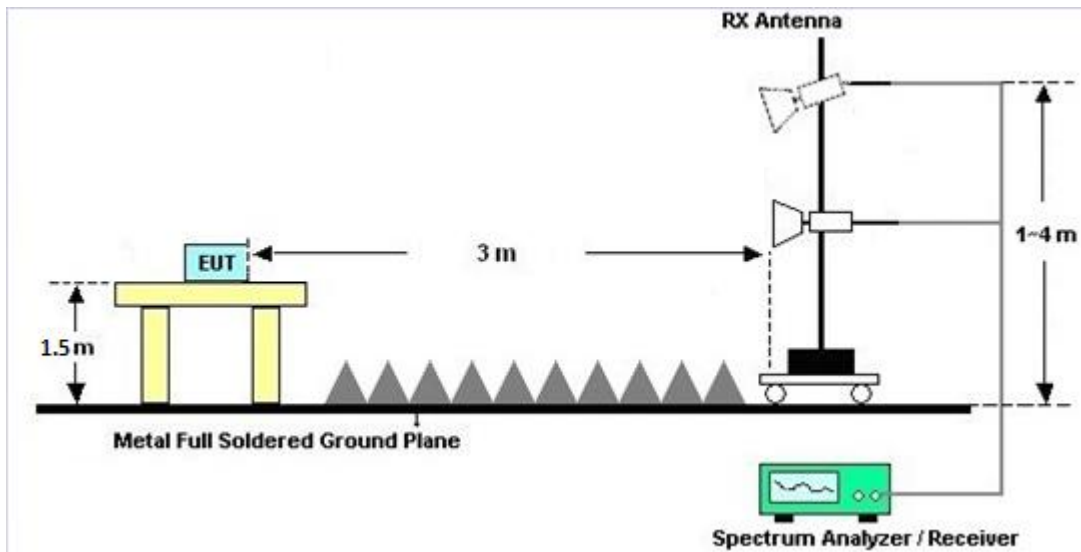



### **3.2.5 Test Results of Radiated Emissions (9 kHz ~ 30 MHz)**

The low frequency, which started from 9 kHz to 30MHz, was pre-scanned and the result which was 20dB lower than the limit line was not reported.

There is a comparison data of both open-field test site and alternative test site - semi-Anechoic chamber according to 414788 D01 Radiated Test Site v01r01, and the result came out very similar.

### **3.2.6 Test Result of Radiated Band Edges**

Please refer to Appendix B and C.

### **3.2.7 Duty Cycle**

Please refer to Appendix D.

### **3.2.8 Test Result of Unwanted Radiated Emission (30MHz ~ 10th Harmonic)**

Please refer to Appendix B and C.



### **3.3 Antenna Requirements**

#### **3.3.1 Standard Applicable**

If transmitting antenna directional gain is greater than 6 dBi, both the peak transmit power and the peak power spectral density shall be reduced by the amount in dB that the directional gain of the antenna exceeds 6 dBi.

#### **3.3.2 Antenna Anti-Replacement Construction**

An embedded-in antenna design is used.

#### **3.3.3 Antenna Gain**

The antenna peak gain of EUT is less than 6 dBi. Therefore, it is not necessary to reduce maximum peak output power limit.



## 4 List of Measuring Equipment

Instrument	Manufacturer	Model No.	Serial No.	Characteristics	Calibration Date	Test Date	Due Date	Remark
Loop Antenna	Rohde & Schwarz	HFH2-Z2	100488	9 kHz~30 MHz	Jan. 09, 2020	Jul. 10, 2020~ Jul. 11, 2020	Jan. 08, 2021	Radiation (03CH15-HY)
Bilog Antenna	TESEQ	CBL6111D&008 00N1D01N-06	41912&05	30MHz to 1GHz	Feb. 09, 2020	Jul. 10, 2020~ Jul. 11, 2020	Feb. 08, 2021	Radiation (03CH15-HY)
Amplifier	SONOMA	310N	363440	9kHz~1GHz	Dec. 27, 2019	Jul. 10, 2020~ Jul. 11, 2020	Dec. 26, 2020	Radiation (03CH15-HY)
Horn Antenna	SCHWARZBE CK	BBHA 9120 D	9120D-162 0	1-18GHz	Oct. 28, 2019	Jul. 10, 2020~ Jul. 11, 2020	Oct. 27, 2020	Radiation (03CH15-HY)
SHF-EHF Horn Antenna	SCHWARZBE CK	BBHA 9170	BBHA9170 584	18GHz- 40GHz	Dec. 10, 2019	Jul. 10, 2020~ Jul. 11, 2020	Dec. 09, 2020	Radiation (03CH15-HY)
Preamplifier	Jet-Power	JPA0118-55-30 3	171000180 0055006	1GHz~18GHz	May 07, 2020	Jul. 10, 2020~ Jul. 11, 2020	May 06, 2021	Radiation (03CH15-HY)
Preamplifier	Keysight	83017A	MY532701 95	1GHz~26.5GHz	Aug. 23, 2019	Jul. 10, 2020~ Jul. 11, 2020	Aug. 22, 2020	Radiation (03CH15-HY)
Preamplifier	EMEC	EM18G40G	060715	18GHz ~ 40GHz	Dec. 13, 2019	Jul. 10, 2020~ Jul. 11, 2020	Dec. 12, 2020	Radiation (03CH15-HY)
EMI Test Receiver	Keysight	N9038A (MXE)	MY541300 85	20MHz~8.4GHz	Nov. 01, 2019	Jul. 10, 2020~ Jul. 11, 2020	Oct. 31, 2020	Radiation (03CH15-HY)
Spectrum Analyzer	Agilent	E4446A	MY501801 36	3Hz~44GHz	May 04, 2020	Jul. 10, 2020~ Jul. 11, 2020	May 03, 2021	Radiation (03CH15-HY)
Antenna Mast	ChainTek	MBS-520-1	N/A	1m~4m	N/A	Jul. 10, 2020~ Jul. 11, 2020	N/A	Radiation (03CH15-HY)
Turn Table	ChainTek	T-200-S-1	N/A	0~360 Degree	N/A	Jul. 10, 2020~ Jul. 11, 2020	N/A	Radiation (03CH15-HY)
Software	Audix	E3 6.2009-8-24 (k5)	RK-00045 1	N/A	N/A	Jul. 10, 2020~ Jul. 11, 2020	N/A	Radiation (03CH15-HY)
RF Cable	HUBER + SUHNER	SUCOFLEX 104	MY36980/ 4	30M-18G	Apr. 14, 2020	Jul. 10, 2020~ Jul. 11, 2020	Apr. 13, 2021	Radiation (03CH15-HY)
RF Cable	HUBER + SUHNER	SUCOFLEX 104	MY9838/4 PE	30M-18G	Apr. 14, 2020	Jul. 10, 2020~ Jul. 11, 2020	Apr. 13, 2021	Radiation (03CH15-HY)
RF Cable	HUBER + SUHNER	SUCOFLEX 104	MY37710/ 4	30M-18G	Apr. 17, 2020	Jul. 10, 2020~ Jul. 11, 2020	Apr. 16, 2021	Radiation (03CH15-HY)
RF Cable	HUBER + SUHNER	SUCOFLEX 102	505134/2	30MHz-40GHz	Feb. 25, 2020	Jul. 10, 2020~ Jul. 11, 2020	Feb. 24, 2021	Radiation (03CH15-HY)
RF Cable	HUBER + SUHNER	SUCOFLEX 102	800740/2	30MHz-40GHz	Feb. 25, 2020	Jul. 10, 2020~ Jul. 11, 2020	Feb. 24, 2021	Radiation (03CH15-HY)
Filter	Wainwright	WLK4-1000-15 30-8000-40SS	SN4	1.53G Low Pass	Jul. 03, 2020	Jul. 10, 2020~ Jul. 11, 2020	Jul. 02, 2021	Radiation (03CH15-HY)
Filter	Wainwright	WHKX8-5872.5 -6750-18000-40 ST	SN6	6.75GHz High Pass Filter	Jul. 03, 2020	Jul. 10, 2020~ Jul. 11, 2020	Jul. 02, 2021	Radiation (03CH15-HY)
Hygrometer	Testo	HTC-1	2	N/A	Mar. 02, 2020	Jul. 10, 2020~ Jul. 24, 2020	Mar. 01, 2021	Conducted (TH05-HY)
Power Sensor	DARE	RPR3006W	16I00054S NO10	10MHz~6GHz	Dec. 23, 2019	Jul. 10, 2020~ Jul. 24, 2020	Dec. 22, 2020	Conducted (TH05-HY)
Switch Box & RF Cable	Burgeon	ETF-058	EC130048 4	N/A	Aug. 22, 2019	Jul. 10, 2020~ Jul. 24, 2020	Aug. 21, 2020	Conducted (TH05-HY)
Signal Analyzer	Rohde & Schwarz	FSV40	101566	10Hz~40GHz	Jul. 15, 2019	Jul. 10, 2020	Jul. 14, 2020	Conducted (TH05-HY)
Signal Analyzer	Rohde & Schwarz	FSV40	101565	10Hz~40GHz	Jun. 19, 2020	Jul. 24, 2020	Jun. 18, 2021	Conducted (TH05-HY)
Power Supply	GW Instek	SPS-606	GES84293 1	NA	Aug. 19, 2019	Jul. 24, 2020	Aug. 18, 2020	Conducted (TH05-HY)



## 5 Uncertainty of Evaluation

### Uncertainty of Radiated Emission Measurement (30 MHz ~ 1000 MHz)

Measuring Uncertainty for a Level of Confidence of 95% ( $U = 2Uc(y)$ )	5.0
---	-----

### Uncertainty of Radiated Emission Measurement (1000 MHz ~ 18000 MHz)

Measuring Uncertainty for a Level of Confidence of 95% ( $U = 2Uc(y)$ )	5.4
---	-----

### Uncertainty of Radiated Emission Measurement (18000 MHz ~ 40000 MHz)

Measuring Uncertainty for a Level of Confidence of 95% ( $U = 2Uc(y)$ )	5.0
---	-----

**Appendix A. Test Result of Conducted Test Items****<CDD Mode>**

Test Engineer:	Ryan	Temperature:	21.2~24.1	°C
Test Date:	2020/7/10	Relative Humidity:	47.2~57.8	%

**TEST RESULTS DATA**  
**Average Power Table**

Band IV MIMO												
Mod.	Data Rate	NTX	CH.	Freq. (MHz)	Average Conducted Power (dBm)			FCC Conducted Power Limit (dBm)		DG (dBi)		Pass/Fail
					Ant 4	Ant 3	SUM	Ant 4	Ant 3	Ant 4	Ant 3	
11a	6Mbps	2	149	5745	19.60	20.50	23.08	30.00		1.00		Pass
11a	6Mbps	2	157	5785	20.90	18.90	23.02	30.00		1.00		Pass
11a	6Mbps	2	165	5825	19.40	20.60	23.05	30.00		1.00		Pass
HT20	MCS0	2	149	5745	18.90	20.10	22.55	30.00		1.00		Pass
HT20	MCS0	2	157	5785	19.00	20.60	22.88	30.00		1.00		Pass
HT20	MCS0	2	165	5825	19.00	20.20	22.65	30.00		1.00		Pass
HT40	MCS0	2	151	5755	18.70	20.20	22.52	30.00		1.00		Pass
HT40	MCS0	2	159	5795	18.70	20.20	22.52	30.00		1.00		Pass
VHT20	MCS0	2	149	5745	18.80	20.20	22.57	30.00		1.00		Pass
VHT20	MCS0	2	157	5785	18.60	20.20	22.48	30.00		1.00		Pass
VHT20	MCS0	2	165	5825	18.90	20.20	22.61	30.00		1.00		Pass
VHT40	MCS0	2	151	5755	18.40	19.70	22.11	30.00		1.00		Pass
VHT40	MCS0	2	159	5795	18.40	19.80	22.17	30.00		1.00		Pass
VHT80	MCS0	2	155	5775	18.20	19.50	21.91	30.00		1.00		Pass

## &lt;TXBF Mode&gt;

Test Engineer:	Ryan Lin	Temperature:	21.2~24.1	°C
Test Date:	2020/7/24	Relative Humidity:	47.2~57.8	%

**TEST RESULTS DATA**  
**Average Power Table**

Band IV MIMO												
Mod.	Data Rate	NTX	CH.	Freq. (MHz)	Average Conducted Power (dBm)			FCC Conducted Power Limit (dBm)		DG (dBi)		Pass/Fail
					Ant 4	Ant 3	SUM	Ant 4	Ant 3	Ant 4	Ant 3	
VHT20	MCS0	2	149	5745	16.00	16.40	19.21	30.00		3.62		Pass
VHT20	MCS0	2	157	5785	16.30	17.00	19.67	30.00		3.62		Pass
VHT20	MCS0	2	165	5825	16.20	17.00	19.63	30.00		3.62		Pass
VHT40	MCS0	2	151	5755	16.40	17.00	19.72	30.00		3.62		Pass
VHT40	MCS0	2	159	5795	16.20	16.70	19.47	30.00		3.62		Pass
VHT80	MCS0	2	155	5775	16.10	16.80	19.47	30.00		3.62		Pass



## Appendix B. Radiated Spurious Emission

Test Engineer :	Leo Lee, Mancy Chou and Bigshow Wang	Temperature :	22.1~23.1°C
		Relative Humidity :	52~61%

### Band 4 - 5725~5850MHz

#### WIFI 802.11ac VHT80 (Band Edge @ 3m)

WIFI	Note	Frequency	Level	Over	Limit	Read	Antenna	Path	Preamp	Ant	Table	Peak	Pol.	
Ant.				Limit	Line	Level	Factor	Loss	Factor	Pos	Pos	Avg.		
4+3		( MHz )	( dBμV/m )	( dB )	( dBμV/m )	( dBμV )	( dB/m )	( dB )	( dB )	( cm )	( deg )	( P/A )	( H/V )	
802.11ac VHT80 CH 155 5775MHz		5629.6	54.38	-13.82	68.2	42.16	31.84	10.89	30.51	100	5	P	H	
		5699.6	68.36	-36.55	104.91	56.04	32	10.87	30.55	100	5	P	H	
		5719.2	72.82	-37.76	110.58	60.52	32	10.87	30.57	100	5	P	H	
		5720.6	73.15	-39.02	112.17	60.85	32	10.87	30.57	100	5	P	H	
	*	5775	105.86	-	-	93.5	32.1	10.86	30.6	100	5	P	H	
	*	5775	96.77	-	-	84.41	32.1	10.86	30.6	100	5	A	H	
		5851.8	65.99	-52.11	118.1	53.45	32.21	10.98	30.65	100	5	P	H	
		5855.8	64.92	-45.66	110.58	52.36	32.22	10.99	30.65	100	5	P	H	
		5875.2	57.45	-47.6	105.05	44.77	32.3	11.04	30.66	100	5	P	H	
		5928.8	52.23	-15.97	68.2	39.3	32.46	11.17	30.7	100	5	P	H	
														H
			5642.4	52.31	-15.89	68.2	40.12	31.82	10.89	30.52	100	360	P	V
			5696.4	67.47	-35.08	102.55	55.16	31.99	10.87	30.55	100	360	P	V
			5719.8	70.82	-39.92	110.74	58.52	32	10.87	30.57	100	360	P	V
			5723.2	71.01	-47.09	118.1	58.71	32	10.87	30.57	100	360	P	V
	*		5775	104	-	-	91.64	32.1	10.86	30.6	100	360	P	V
	*		5775	95.9	-	-	83.54	32.1	10.86	30.6	100	360	A	V
			5850.8	65.53	-54.85	120.38	53	32.2	10.98	30.65	100	360	P	V
			5855.8	64.67	-45.91	110.58	52.11	32.22	10.99	30.65	100	360	P	V
			5878.8	60.36	-42.02	102.38	47.65	32.32	11.05	30.66	100	360	P	V
		5945.8	51.82	-16.38	68.2	38.82	32.49	11.22	30.71	100	360	P	V	
													V	
Remark	1. No other spurious found. 2. All results are PASS against Peak and Average limit line.													



**Band 4 5725~5850MHz  
WIFI 802.11ac VHT80 (Harmonic @ 3m)**

WIFI Ant. 4+3	Note	Frequency ( MHz )	Level ( dBµV/m )	Over Limit ( dB )	Limit Line ( dBµV/m )	Read Level ( dBµV )	Antenna Factor ( dB/m )	Path Loss ( dB )	Preamp Factor ( dB )	Ant Pos ( cm )	Table Pos ( deg )	Peak Avg. ( P/A )	Pol. ( H/V )	
802.11ac VHT80 CH 155 5775MHz		11550	48.99	-25.01	74	54.64	40.35	14.96	60.96	100	0	P	H	
		17325	51.44	-16.76	68.2	49.62	41.45	19.08	58.71	100	0	P	H	
													H	
													H	
			11550	48.66	-25.34	74	54.31	40.35	14.96	60.96	100	0	P	V
			17325	51.16	-17.04	68.2	49.34	41.45	19.08	58.71	100	0	P	V
														V
														V
<b>Remark</b>	1. No other spurious found. 2. All results are PASS against Peak and Average limit line.													



Emission below 1GHz

5GHz WIFI 802.11ac VHT80 (LF @ 3m)

WIFI	Note	Frequency	Level	Over	Limit	Read	Antenna	Path	Preamp	Ant	Table	Peak	Pol.	
Ant.				Limit	Line	Level	Factor	Loss	Factor	Pos	Pos	Avg.		
4+3		( MHz )	( dBμV/m )	( dB )	( dBμV/m )	( dBμV )	( dB/m )	( dB )	( dB )	( cm )	( deg )	(P/A)	(H/V)	
5GHz 802.11ac VHT80 LF		72.68	21.66	-18.34	40	40.37	12.74	1.13	32.58	-	-	P	H	
		155.13	20.49	-23.01	43.5	34.17	17.04	1.72	32.44	-	-	P	H	
		166.77	21.15	-22.35	43.5	35.63	16.13	1.8	32.41	-	-	P	H	
		303.54	23.31	-22.69	46	34.29	19.13	2.4	32.51	-	-	P	H	
		730.34	30.2	-15.8	46	31.56	27.31	3.77	32.44	-	-	P	H	
		925.31	32.91	-13.09	46	30.84	29.24	4.39	31.56	100	0	P	H	
														H
														H
														H
														H
														H
														H
														H
														H
														H
			37.76	22.64	-17.36	40	33.68	20.51	0.79	32.34	-	-	P	V
			72.68	21.73	-18.27	40	40.44	12.74	1.13	32.58	-	-	P	V
			120.21	20.95	-22.55	43.5	34.22	17.65	1.51	32.43	-	-	P	V
		185.2	17.85	-25.65	43.5	33.25	15.06	1.92	32.38	-	-	P	V	
		746.83	30.44	-15.56	46	31.42	27.66	3.82	32.46	-	-	P	V	
		838.01	31.62	-14.38	46	30.88	28.49	4.09	31.84	100	0	P	V	
													V	
													V	
													V	
													V	
													V	
													V	
													V	
<b>Remark</b>	1. No other spurious found. 2. All results are PASS against limit line.													



**Note symbol**

*	<b>Fundamental Frequency</b> which can be ignored. However, the level of any unwanted emissions shall not exceed the level of the fundamental frequency.
!	Test result is <b>over limit</b> line.
P/A	<b>Peak</b> or <b>Average</b>
H/V	<b>Horizontal</b> or <b>Vertical</b>



A calculation example for radiated spurious emission is shown as below:

WIFI	Note	Frequency	Level	Over	Limit	Read	Antenna	Path	Preamp	Ant	Table	Peak	Pol.
Ant.				Limit	Line	Level	Factor	Loss	Factor	Pos	Pos	Avg.	
4+3		( MHz )	( dBμV/m )	( dB )	( dBμV/m )	( dBμV )	( dB/m )	( dB )	( dB )	( cm )	( deg )	( P/A )	( H/V )
802.11b		2390	55.45	-18.55	74	54.51	32.22	4.58	35.86	103	308	P	H
CH 01													
2412MHz		2390	43.54	-10.46	54	42.6	32.22	4.58	35.86	103	308	A	H

1. Path Loss(dB) = Cable loss(dB) + Filter loss(dB) + Attenuator loss(dB)
2. Level(dBμV/m) = Antenna Factor(dB/m) + Path Loss(dB) + Read Level(dBμV) - Preamp Factor(dB)
3. Over Limit(dB) = Level(dBμV/m) – Limit Line(dBμV/m)

**For Peak Limit @ 2390MHz:**

1. Level(dBμV/m)  
= Antenna Factor(dB/m) + Path Loss(dB) + Read Level(dBμV) - Preamp Factor(dB)  
= 32.22(dB/m) + 4.58(dB) + 54.51(dBμV) – 35.86 (dB)  
= 55.45 (dBμV/m)
2. Over Limit(dB)  
= Level(dBμV/m) – Limit Line(dBμV/m)  
= 55.45(dBμV/m) – 74(dBμV/m)  
= -18.55(dB)

**For Average Limit @ 2390MHz:**

1. Level(dBμV/m)  
= Antenna Factor(dB/m) + Path Loss(dB) + Read Level(dBμV) - Preamp Factor(dB)  
= 32.22(dB/m) + 4.58(dB) + 42.6(dBμV) – 35.86 (dB)  
= 43.54 (dBμV/m)
2. Over Limit(dB) = Level(dBμV/m) – Limit Line(dBμV/m)  
= 43.54(dBμV/m) – 54(dBμV/m)  
= -10.46(dB)

**Both peak and average measured complies with the limit line, so test result is “PASS”.**



## Appendix C. Radiated Spurious Emission Plots

Test Engineer :	Leo Lee, Mancy Chou and Bigshow Wang	Temperature :	22.1~23.1°C
		Relative Humidity :	52~61%



**Band 4 - 5725~5850MHz**  
**WIFI 802.11ac VHT80 (Band Edge @ 3m)**

WIFI	Band 4 5725~5850MHz Band Edge @ 3m	
ANT	802.11ac VHT80 CH155 5775MHz	
4+3	Horizontal	Fundamental
<b>Peak</b>	<p>Site : 03CH15-HY            Condition : PEAK_BE(B4)_16-24 3m 91200_15_1620 HORIZONTAL            RBW:1000.000KHz VBW:3000.000KHz SWT:Auto            Detector : Peak            Project : 051232-02</p>	<p>Site : 03CH15-HY            Condition : PEAK(LINE) 3m 91200_15_1620 HORIZONTAL            RBW:1000.000KHz VBW:3000.000KHz SWT:Auto            Detector : Peak            Project : 051232-02</p>
<b>Peak</b>	<p>Site : 03CH15-HY            Condition : PEAK_BE(B4)_16-24 3m 91200_15_1620 HORIZONTAL            RBW:1000.000KHz VBW:3000.000KHz SWT:Auto            Detector : Peak            Project : 051232-02</p>	<b>Left blank</b>

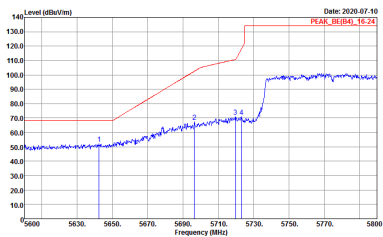
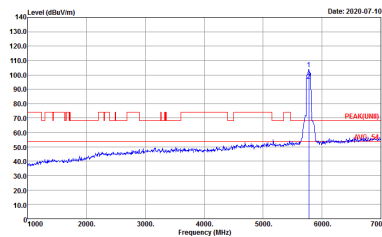
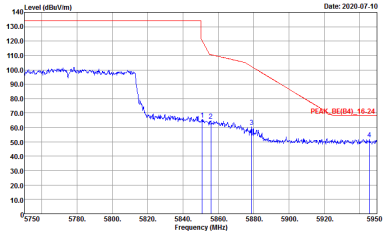

WIFI	Band 4 5725~5850MHz Band Edge @ 3m	
ANT	802.11ac VHT80 CH155 5775MHz	
4+3	Vertical	Fundamental
<p><b>Peak</b></p>	 <p>Site : 03CH15-HY            Condition : PEAK_BE(B4)_16-24 3m 91200_15_1620 VERTICAL            Detector : Peak            Project : 051232-02</p>	 <p>Site : 03CH15-HY            Condition : PEAK(LINII) 3m 91200_15_1620 VERTICAL            Detector : Peak            Project : 051232-02</p>
<p><b>Peak</b></p>	 <p>Site : 03CH15-HY            Condition : PEAK_BE(B4)_16-24 3m 91200_15_1620 VERTICAL            Detector : Peak            Project : 051232-02</p>	<p><b>Left blank</b></p>



**Band 4 - 5725~5850MHz**  
**WIFI 802.11ac VHT80 (Harmonic @ 3m)**

<b>WIFI</b>	<b>Band 4 5725~5850MHz Harmonic @ 3m</b>	
<b>ANT</b>	<b>802.11ac VHT80 CH155 5775MHz</b>	
<b>4+3</b>	<b>Horizontal</b>	<b>Vertical</b>
<b>Peak</b> <b>Avg.</b>	<p>Site : 03CH15-HY          Condition : PEAR(LINET) 3m 91200_15_1620 HORIZONTAL          Detector : Peak          Project : 051232-02</p>	<p>Site : 03CH15-HY          Condition : PEAR(LINET) 3m 91200_15_1620 VERTICAL          Detector : Peak          Project : 051232-02</p>



Emission below 1GHz  
5GHz WIFI 802.11ac VHT80 (LF)

WIFI	5GHz 5725-5850MHz	
ANT	802.11ac VHT80 LF	
4+3	Horizontal	Vertical
QP / Peak	<p>Site : 03CH15-HY Condition : QP 3m BIL06_15_41912 HORIZONTAL Detector : Peak Project : 051232-02</p>	<p>Site : 03CH15-HY Condition : QP 3m BIL06_15_41912 VERTICAL Detector : Peak Project : 051232-02</p>



## Appendix D. Duty Cycle Plots

Antenna	Band	Duty Cycle(%)	T(us)	1/T(kHz)	VBW Setting	Duty Factor(dB)
4+3	5GHz 802.11ac VHT80 for Ant. 4	92.68	456	2.19	3kHz	0.33
4+3	5GHz 802.11ac VHT80 for Ant. 3	92.68	456	2.19	3kHz	0.33



MIMO <Ant. 4>

802.11ac VHT80

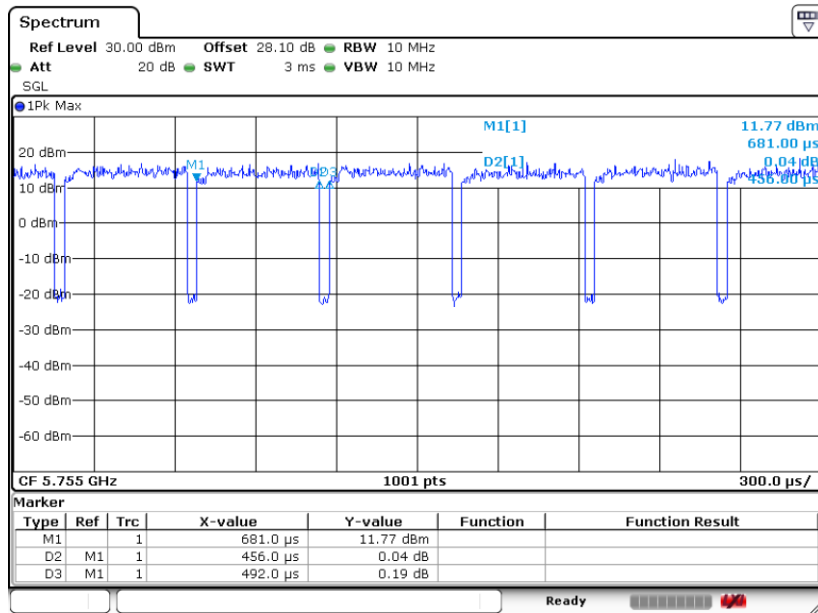

Date: 10.JUL.2020 20:02:35

MIMO <Ant. 3>

802.11ac VHT80

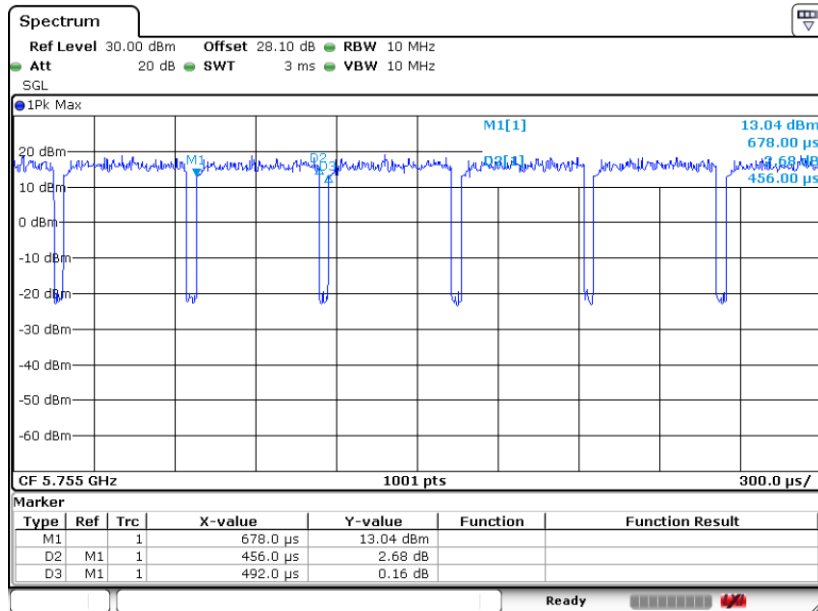

Date: 10.JUL.2020 20:03:57

—THE END—