

## System Check\_Head\_835MHz

### DUT: D835V2-4d167

Communication System CW; Frequency: 835 MHz; Duty Cycle: 1:1

Medium: HSL\_850\_200423 Medium parameters used:  $f = 835$  MHz;  $\sigma = 0.875$  S/m;  $\epsilon_r = 41.872$ ;  $\rho = 1000$  kg/m<sup>3</sup>

Ambient Temperature : 23.5 °C ; Liquid Temperature : 22.5 °C

DASY5 Configuration:

- Probe: EX3DV4 - SN7306; ConvF(9.73, 9.73, 9.73) @ 835 MHz; Calibrated: 2019/7/22
- Sensor-Surface: 1.4mm (Mechanical Surface Detection)
- Electronics: DAE3 Sn577; Calibrated: 2019/9/17
- Phantom: SAM\_Left; Type: QD000P40CD; Serial: TP:1801
- Measurement SW: DASY52, Version 52.10 (4); SEMCAD X Version 14.6.14 (7483)

**Pin=250mW/Area Scan (61x61x1):** Interpolated grid: dx=1.500 mm, dy=1.500 mm  
Maximum value of SAR (interpolated) = 3.27 W/kg

**Pin=250mW/Zoom Scan (5x5x7)/Cube 0:** Measurement grid: dx=8mm, dy=8mm, dz=5mm  
Reference Value = 63.08 V/m; Power Drift = -0.10 dB  
Peak SAR (extrapolated) = 3.66 W/kg  
**SAR(1 g) = 2.44 W/kg; SAR(10 g) = 1.61 W/kg**  
Maximum value of SAR (measured) = 3.26 W/kg

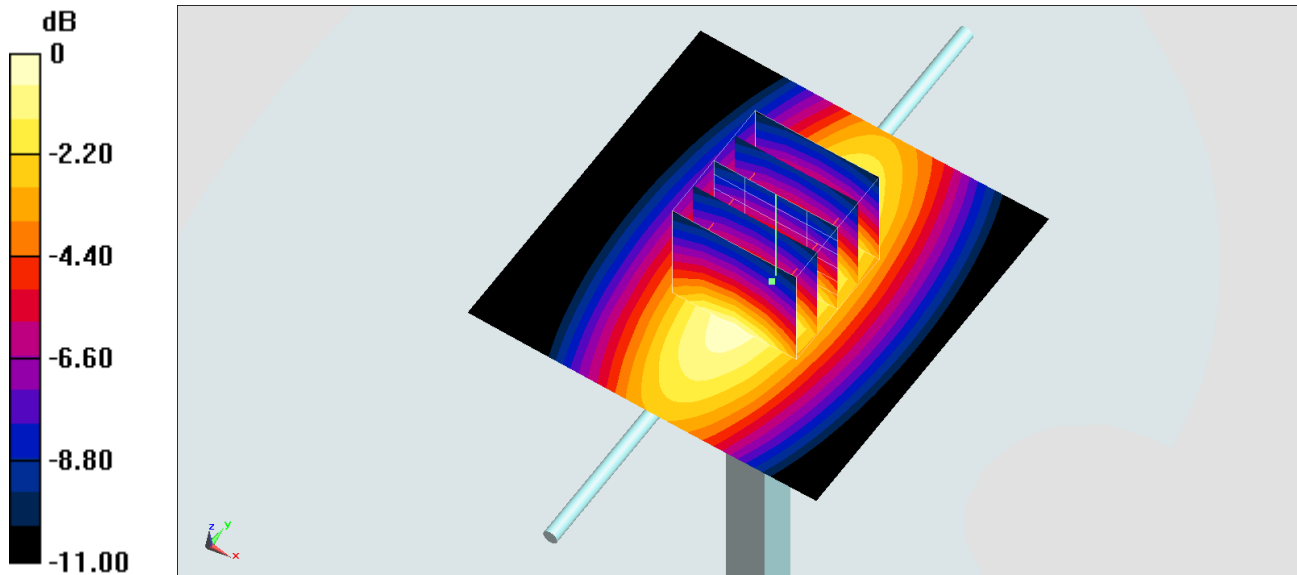

0 dB = 3.26 W/kg = 5.13 dBW/kg

## System Check\_Head\_835MHz

**DUT: D835V2-4d167**

Communication System: CW ; Frequency: 835 MHz;Duty Cycle: 1:1

Medium: HSL\_850\_200425 Medium parameters used:  $f = 835 \text{ MHz}$ ;  $\sigma = 0.889 \text{ S/m}$ ;  $\epsilon_r = 42.429$ ;  $\rho = 1000 \text{ kg/m}^3$

Ambient Temperature :  $23.5 \text{ }^\circ\text{C}$ ; Liquid Temperature :  $22.5 \text{ }^\circ\text{C}$

### DASY5 Configuration

- Probe: ES3DV3 - SN3270;ConvF(6.43, 6.43, 6.43) @ 835 MHz;Calibrated: 2019/9/25
- Sensor-Surface: 3mm (Mechanical Surface Detection)
- Electronics: DAE4 Sn778; Calibrated: 2019/5/21
- Phantom: Twin-SAM V5.0 (30deg probe tilt); Type: QD 000 P40 CD; Serial: 1885
- Measurement SW: DASY52, Version 52.10 (2); SEMCAD X Version 14.6.12 (7450)

**Pin=250mW/Area Scan (61x61x1):** Interpolated grid:  $dx=1.500 \text{ mm}$ ,  $dy=1.500 \text{ mm}$   
Maximum value of SAR (interpolated) =  $2.83 \text{ W/kg}$

**Pin=250mW/Zoom Scan (5x5x7)/Cube 0:** Measurement grid:  $dx=8\text{mm}$ ,  $dy=8\text{mm}$ ,  $dz=5\text{mm}$   
Reference Value =  $58.82 \text{ V/m}$ ; Power Drift =  $-0.15 \text{ dB}$   
Peak SAR (extrapolated) =  $3.58 \text{ W/kg}$   
**SAR(1 g) =  $2.4 \text{ W/kg}$ ; SAR(10 g) =  $1.57 \text{ W/kg}$**   
Maximum value of SAR (measured) =  $2.80 \text{ W/kg}$

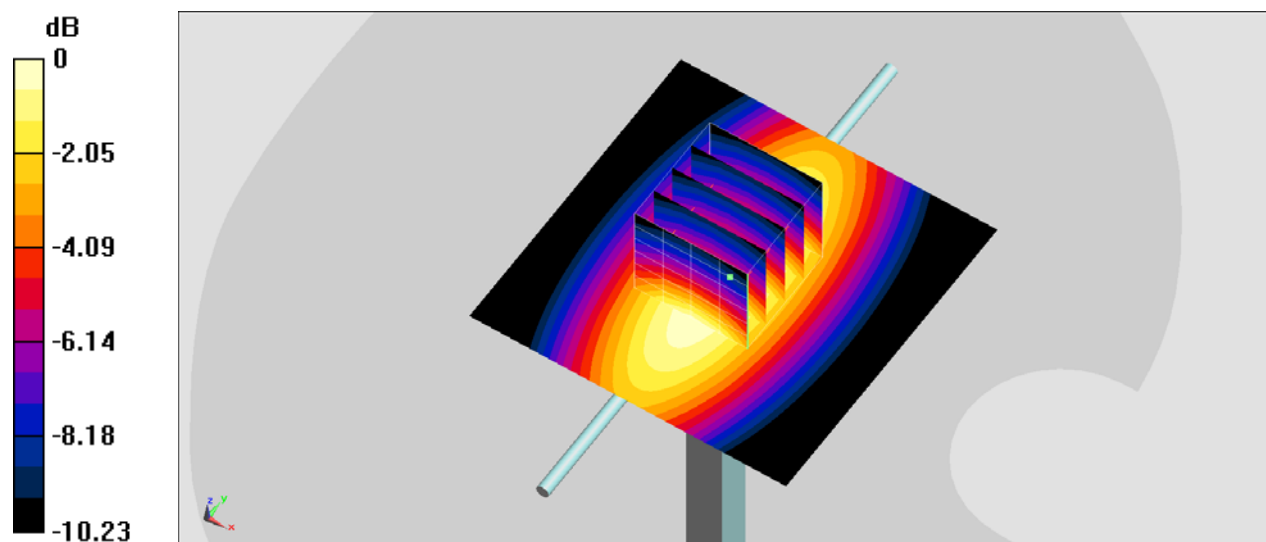

0 dB =  $2.80 \text{ W/kg} = 4.47 \text{ dBW/kg}$

## System Check\_Head\_1750MHz

### DUT: D1750V2-1112

Communication System: CW ; Frequency: 1750 MHz;Duty Cycle: 1:1

Medium: HSL\_1750\_200423 Medium parameters used:  $f = 1750$  MHz;  $\sigma = 1.369$  S/m;  $\epsilon_r = 40.6$ ;  $\rho = 1000$  kg/m<sup>3</sup>

Ambient Temperature : 23.4 °C ; Liquid Temperature : 22.4 °C

### DASY5 Configuration

- Probe: ES3DV3 - SN3270;ConvF(5.41, 5.41, 5.41) @ 1750 MHz;Calibrated: 2019/9/25
- Sensor-Surface: 3mm (Mechanical Surface Detection)
- Electronics: DAE4 Sn778; Calibrated: 2019/5/21
- Phantom: Twin-SAM V5.0 (30deg probe tilt); Type: QD 000 P40 CD; Serial: 1885
- Measurement SW: DASY52, Version 52.10 (2); SEMCAD X Version 14.6.12 (7450)

**Pin=250mW/Area Scan (61x61x1):** Interpolated grid: dx=1.500 mm, dy=1.500 mm  
Maximum value of SAR (interpolated) = 11.3 W/kg

**Pin=250mW/Zoom Scan (5x5x7)/Cube 0:** Measurement grid: dx=8mm, dy=8mm, dz=5mm  
Reference Value = 90.09 V/m; Power Drift = 0.13 dB  
Peak SAR (extrapolated) = 16.0 W/kg  
**SAR(1 g) = 8.87 W/kg; SAR(10 g) = 4.74 W/kg**  
Maximum value of SAR (measured) = 11.1 W/kg

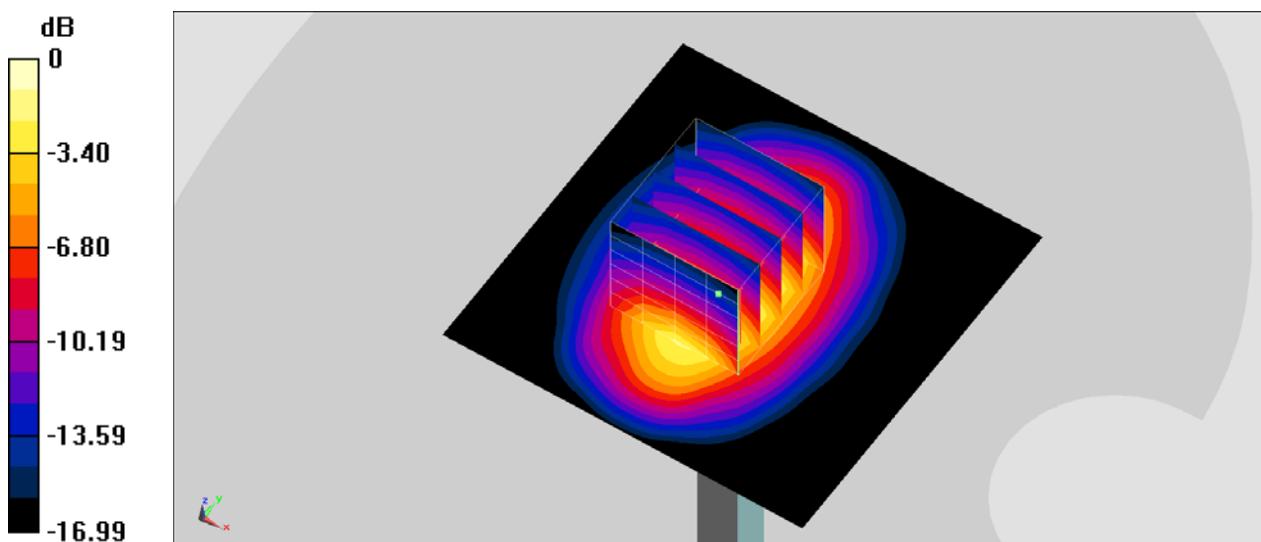

## System Check\_Head\_1750MHz

### DUT: D1750V2-1112

Communication System: CW; Frequency: 1750 MHz; Duty Cycle: 1:1

Medium: HSL\_1750\_200424 Medium parameters used:  $f = 1750$  MHz;  $\sigma = 1.381$  S/m;  $\epsilon_r = 41.532$ ;  $\rho = 1000$  kg/m<sup>3</sup>

Ambient Temperature : 23.5 °C; Liquid Temperature : 22.5 °C

DASY5 Configuration:

- Probe: EX3DV4 - SN7306; ConvF(8.51, 8.51, 8.51) @ 1750 MHz; Calibrated: 2019/7/22
- Sensor-Surface: 1.4mm (Mechanical Surface Detection)
- Electronics: DAE3 Sn577; Calibrated: 2019/9/17
- Phantom: SAM\_Left; Type: QD000P40CD; Serial: TP:1801
- Measurement SW: DASY52, Version 52.10 (4); SEMCAD X Version 14.6.14 (7483)

**Pin=250mW/Area Scan (61x61x1):** Interpolated grid: dx=1.500 mm, dy=1.500 mm  
Maximum value of SAR (interpolated) = 16.0 W/kg

**Pin=250mW/Zoom Scan (5x5x7)/Cube 0:** Measurement grid: dx=8mm, dy=8mm, dz=5mm  
Reference Value = 105.0 V/m; Power Drift = 0.01 dB  
Peak SAR (extrapolated) = 19.2 W/kg  
**SAR(1 g) = 9.08 W/kg; SAR(10 g) = 4.66 W/kg**  
Maximum value of SAR (measured) = 14.7 W/kg

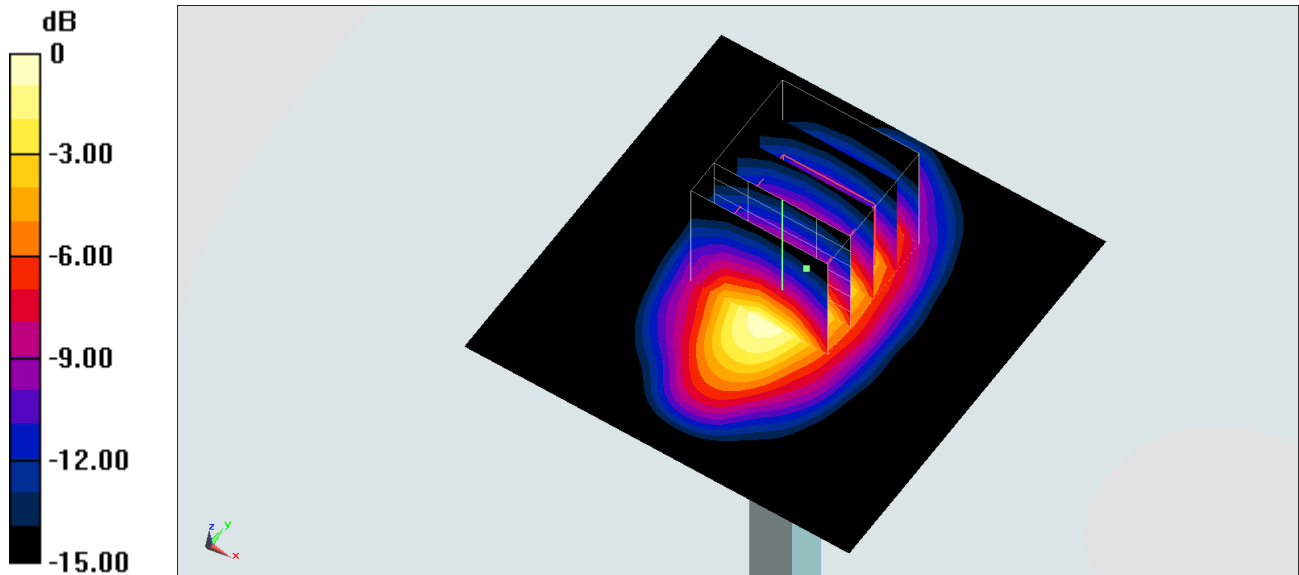

0 dB = 14.7 W/kg = 11.67 dBW/kg

## System Check\_Head\_1900MHz

### DUT: D1900V2-5d185

Communication System: CW; Frequency: 1900 MHz; Duty Cycle: 1:1  
Medium: HSL\_1900\_200423 Medium parameters used:  $f = 1900$  MHz;  $\sigma = 1.415$  S/m;  $\epsilon_r = 39.184$ ;  
 $\rho = 1000$  kg/m<sup>3</sup>  
Ambient Temperature : 23.4 °C ; Liquid Temperature : 22.4 °C

### DASY5 Configuration

- Probe: ES3DV3 - SN3270; ConvF(5.2, 5.2, 5.2) @ 1900 MHz; Calibrated: 2019/9/25
- Sensor-Surface: 3mm (Mechanical Surface Detection)
- Electronics: DAE4 Sn778; Calibrated: 2019/5/21
- Phantom: Twin-SAM V5.0 (30deg probe tilt); Type: QD 000 P40 CD; Serial: 1885
- Measurement SW: DASY52, Version 52.10 (2); SEMCAD X Version 14.6.12 (7450)

**Pin=250mW/Area Scan (61x61x1):** Interpolated grid: dx=1.500 mm, dy=1.500 mm  
Maximum value of SAR (interpolated) = 12.0 W/kg

**Pin=250mW/Zoom Scan (5x5x7)/Cube 0:** Measurement grid: dx=8mm, dy=8mm, dz=5mm  
Reference Value = 90.12 V/m; Power Drift = 0.04 dB  
Peak SAR (extrapolated) = 17.1 W/kg  
**SAR(1 g) = 9.36 W/kg; SAR(10 g) = 4.86 W/kg**  
Maximum value of SAR (measured) = 11.7 W/kg

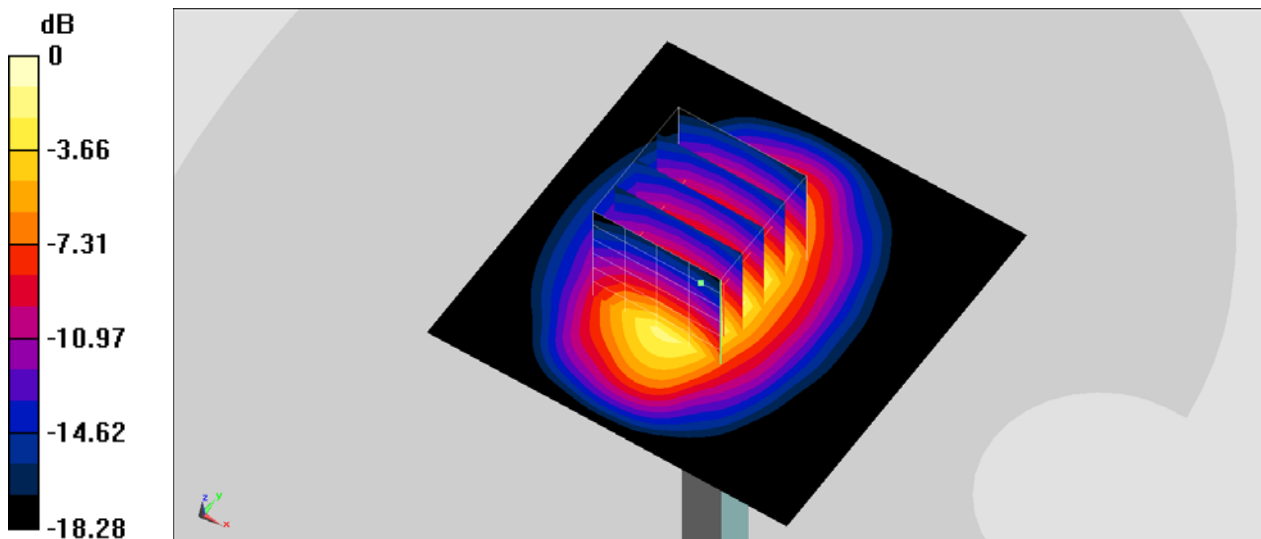

## System Check\_Head\_1900MHz

### DUT: D1900V2-5d185

Communication System: CW; Frequency: 1900 MHz; Duty Cycle: 1:1

Medium: HSL\_1900 Medium parameters used:  $f = 1900$  MHz;  $\sigma = 1.379$  S/m;  $\epsilon_r = 40.691$ ;  $\rho = 1000$  kg/m<sup>3</sup>

Ambient Temperature : 23.5 °C; Liquid Temperature : 22.5 °C

DASY5 Configuration:

- Probe: EX3DV4 - SN7306; ConvF(8.15, 8.15, 8.15) @ 1900 MHz; Calibrated: 2019/7/22
- Sensor-Surface: 1.4mm (Mechanical Surface Detection)
- Electronics: DAE3 Sn577; Calibrated: 2019/9/17
- Phantom: SAM\_Left; Type: QD000P40CD; Serial: TP:1801
- Measurement SW: DASY52, Version 52.10 (4); SEMCAD X Version 14.6.14 (7483)

**Pin=250mW/Area Scan (61x61x1):** Interpolated grid: dx=1.500 mm, dy=1.500 mm

Maximum value of SAR (interpolated) = 16.4 W/kg

**Pin=250mW/Zoom Scan (5x5x7)/Cube 0:** Measurement grid: dx=8mm, dy=8mm, dz=5mm

Reference Value = 110.0 V/m; Power Drift = -0.08 dB

Peak SAR (extrapolated) = 19.7 W/kg

**SAR(1 g) = 10.1 W/kg; SAR(10 g) = 5.14 W/kg**

Maximum value of SAR (measured) = 15.5 W/kg

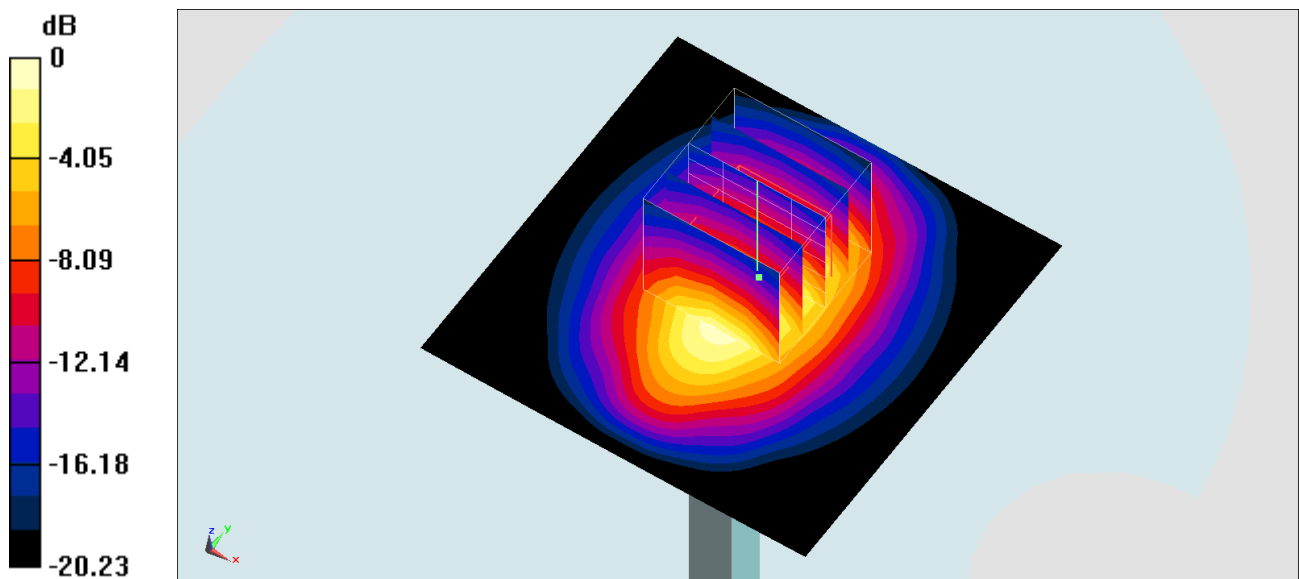

0 dB = 15.5 W/kg = 11.90 dBW/kg

## System Check\_Head\_2450MHz

### DUT: D2450V2-736

Communication System: CW; Frequency: 2450 MHz; Duty Cycle: 1:1

Medium: HSL\_2450\_200422 Medium parameters used :  $f = 2450$  MHz;  $\sigma = 1.795$  S/m;  $\epsilon_r = 38.311$ ;  $\rho = 1000$  kg/m<sup>3</sup>

Ambient Temperature : 23.5 °C ; Liquid Temperature : 22.5 °C

DASY5 Configuration:

- Probe: EX3DV4 - SN7306; ConvF(7.48, 7.48, 7.48) @ 2450 MHz; Calibrated: 2019/7/22
- Sensor-Surface: 1.4mm (Mechanical Surface Detection)
- Electronics: DAE3 Sn577; Calibrated: 2019/9/17
- Phantom: SAM\_Left; Type: QD000P40CD; Serial: TP:1801
- Measurement SW: DASY52, Version 52.10 (4); SEMCAD X Version 14.6.14 (7483)

**Pin=250mW/Area Scan (81x81x1):** Interpolated grid: dx=1.200 mm, dy=1.200 mm  
Maximum value of SAR (interpolated) = 25.8 W/kg

**Pin=250mW/Zoom Scan (7x7x7)/Cube 0:** Measurement grid: dx=5mm, dy=5mm, dz=5mm  
Reference Value = 116.6 V/m; Power Drift = 0.03 dB  
Peak SAR (extrapolated) = 29.1 W/kg  
**SAR(1 g) = 13.9 W/kg; SAR(10 g) = 6.4 W/kg**  
Maximum value of SAR (measured) = 23.3 W/kg

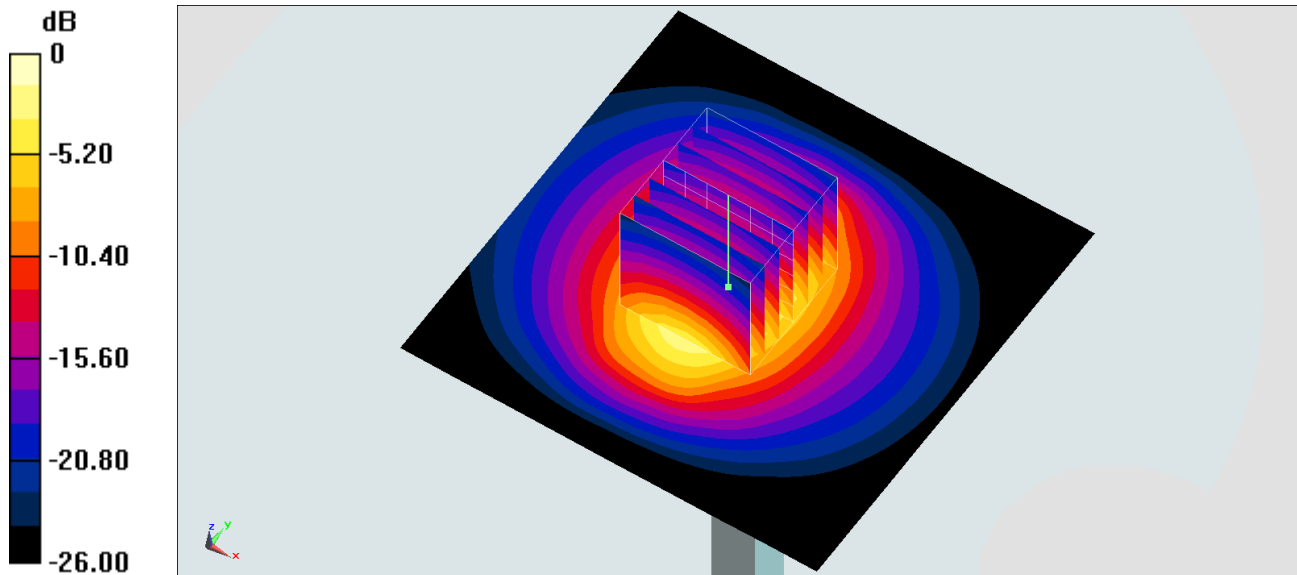

0 dB = 23.3 W/kg = 13.67 dBW/kg

## System Check\_Head\_2450MHz

### DUT: D2450V2-736

Communication System: CW; Frequency: 2450 MHz; Duty Cycle: 1:1

Medium: HSL\_2450\_200425 Medium parameters used :  $f = 2450$  MHz;  $\sigma = 1.791$  S/m;  $\epsilon_r = 39.009$ ;  $\rho = 1000$  kg/m<sup>3</sup>

Ambient Temperature : 23.5 °C; Liquid Temperature : 22.5 °C

DASY5 Configuration:

- Probe: EX3DV4 - SN7306; ConvF(7.48, 7.48, 7.48) @ 2450 MHz; Calibrated: 2019/7/22
- Sensor-Surface: 1.4mm (Mechanical Surface Detection)
- Electronics: DAE3 Sn577; Calibrated: 2019/9/17
- Phantom: SAM\_Left; Type: QD000P40CD; Serial: TP:1801
- Measurement SW: DASY52, Version 52.10 (4); SEMCAD X Version 14.6.14 (7483)

**Pin=250mW/Area Scan (71x71x1):** Interpolated grid: dx=1.200 mm, dy=1.200 mm  
Maximum value of SAR (interpolated) = 19.3 W/kg

**Pin=250mW/Zoom Scan (7x7x7)/Cube 0:** Measurement grid: dx=5mm, dy=5mm, dz=5mm  
Reference Value = 110.9 V/m; Power Drift = 0.09 dB  
Peak SAR (extrapolated) = 25.5 W/kg  
**SAR(1 g) = 12.6 W/kg; SAR(10 g) = 5.91 W/kg**  
Maximum value of SAR (measured) = 20.9 W/kg

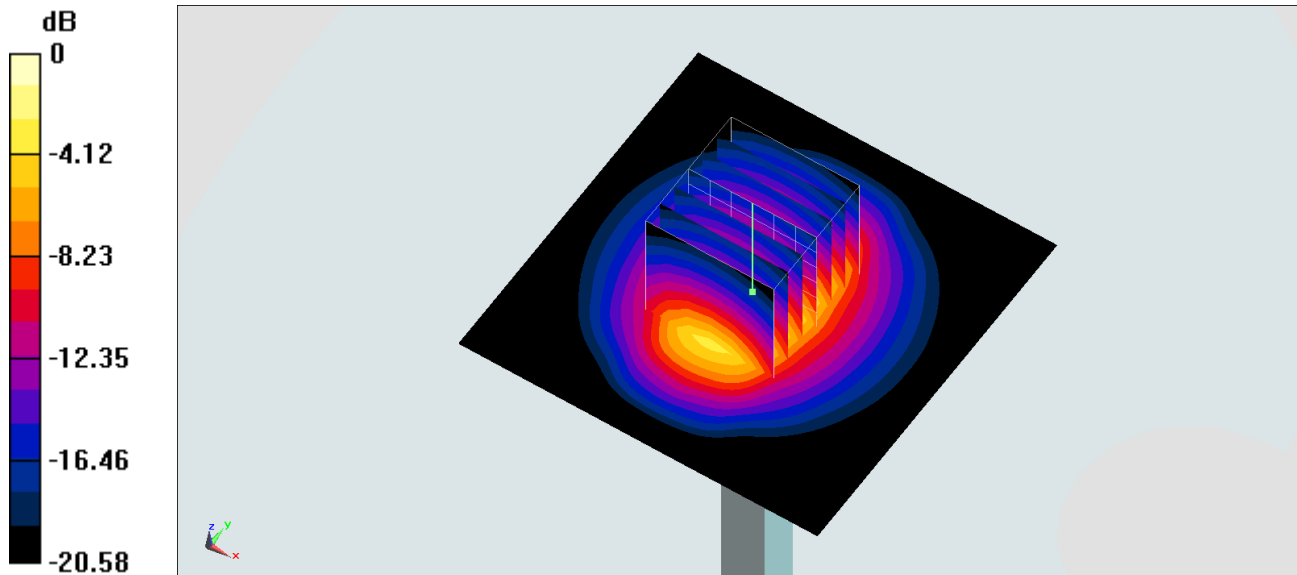

## System Check\_Head\_2450MHz

### DUT: D2450V2-736

Communication System: CW; Frequency: 2450 MHz; Duty Cycle: 1:1

Medium: HSL\_2450\_200430 Medium parameters used :  $f = 2450$  MHz;  $\sigma = 1.836$  S/m;  $\epsilon_r = 39.182$ ;

$\rho = 1000$  kg/m<sup>3</sup>

Ambient Temperature : 23.4 °C ; Liquid Temperature : 22.4 °C

### DASY5 Configuration

- Probe: ES3DV3 - SN3270; ConvF(4.57, 4.57, 4.57) @ 2450 MHz; Calibrated: 2019/9/25
- Sensor-Surface: 3mm (Mechanical Surface Detection)
- Electronics: DAE4 Sn778; Calibrated: 2019/5/21
- Phantom: Twin-SAM V5.0 (30deg probe tilt); Type: QD 000 P40 CD; Serial: 1885
- Measurement SW: DASY52, Version 52.10 (4); SEMCAD X Version 14.6.14 (7483)

**Pin=250mW/Area Scan (71x71x1):** Interpolated grid: dx=1.200 mm, dy=1.200 mm

Maximum value of SAR (interpolated) = 18.5 W/kg

**Pin=250mW/Zoom Scan (7x7x7)/Cube 0:** Measurement grid: dx=5mm, dy=5mm, dz=5mm

Reference Value = 102.2 V/m; Power Drift = 0.01 dB

Peak SAR (extrapolated) = 28.7 W/kg

**SAR(1 g) = 13.8 W/kg; SAR(10 g) = 6.41 W/kg**

Maximum value of SAR (measured) = 17.7 W/kg

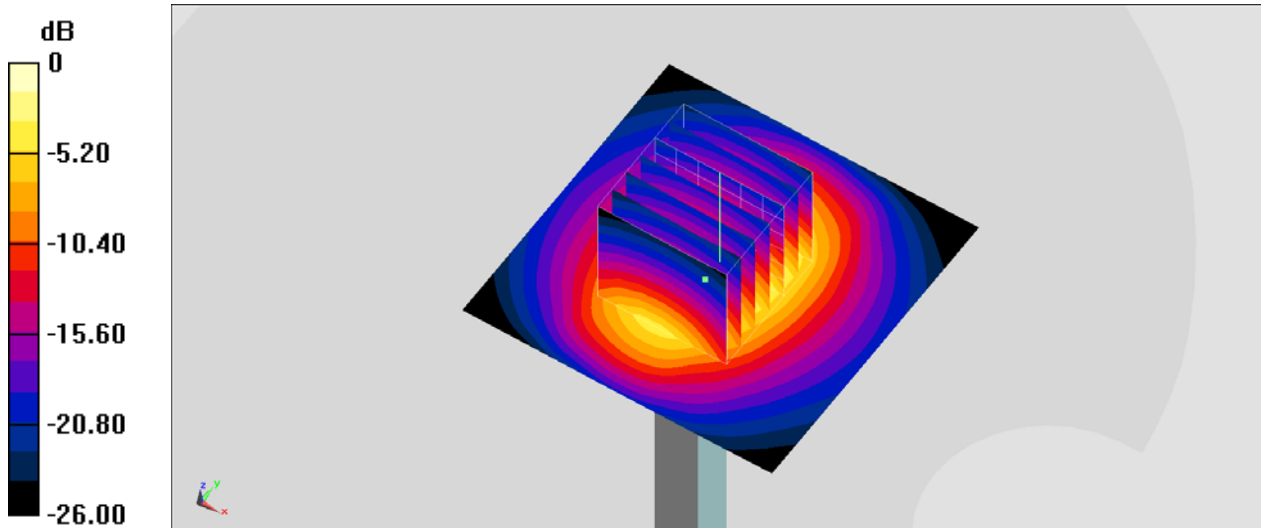

0 dB = 17.7 W/kg = 12.48 dBW/kg

## System Check\_Head\_2600MHz

### DUT: D2600V2-1008

Communication System: CW; Frequency: 2600 MHz; Duty Cycle: 1:1

Medium: HSL\_2600\_200422 Medium parameters used:  $f = 2600$  MHz;  $\sigma = 1.92$  S/m;  $\epsilon_r = 38.089$ ;  $\rho = 1000$  kg/m<sup>3</sup>

Ambient Temperature : 23.4 °C; Liquid Temperature : 22.4 °C

DASY5 Configuration:

- Probe: EX3DV4 - SN7306; ConvF(7.3, 7.3, 7.3) @ 2600 MHz; Calibrated: 2019/7/22
- Sensor-Surface: 1.4mm (Mechanical Surface Detection)
- Electronics: DAE3 Sn577; Calibrated: 2019/9/17
- Phantom: SAM\_Left; Type: QD000P40CD; Serial: TP:1801
- Measurement SW: DASY52, Version 52.10 (4); SEMCAD X Version 14.6.14 (7483)

**Pin=250mW/Area Scan (61x61x1):** Interpolated grid: dx=1.200 mm, dy=1.200 mm

Maximum value of SAR (interpolated) = 26.5 W/kg

**Pin=250mW/Zoom Scan (7x7x7)/Cube 0:** Measurement grid: dx=5mm, dy=5mm, dz=5mm

Reference Value = 115.7 V/m; Power Drift = -0.04 dB

Peak SAR (extrapolated) = 33.0 W/kg

**SAR(1 g) = 14.5 W/kg; SAR(10 g) = 6.31 W/kg**

Maximum value of SAR (measured) = 25.6 W/kg

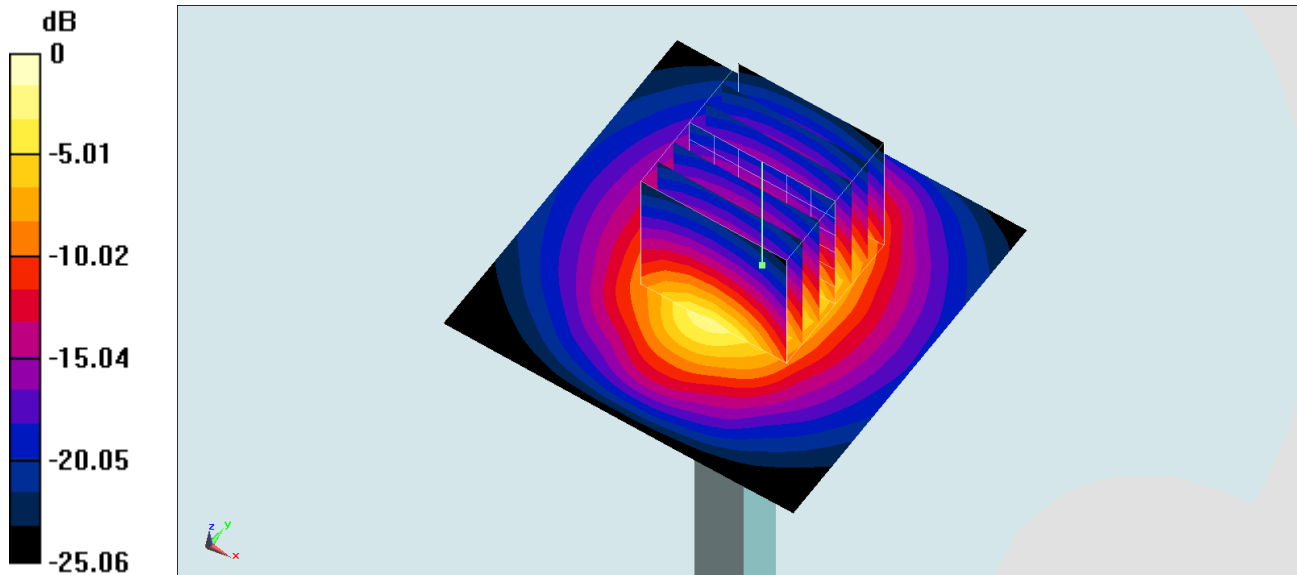

## System Check\_Head\_2600MHz

### DUT: D2600V2-1008

Communication System: CW; Frequency: 2600 MHz; Duty Cycle: 1:1

Medium: HSL\_2600\_200424 Medium parameters used:  $f = 2600$  MHz;  $\sigma = 1.956$  S/m;  $\epsilon_r = 40.439$ ;  
 $\rho = 1000$  kg/m<sup>3</sup>

Ambient Temperature : 23.4 °C ; Liquid Temperature : 22.4 °C

### DASY5 Configuration

- Probe: ES3DV3 - SN3270; ConvF(4.51, 4.51, 4.51) @ 2600 MHz; Calibrated: 2019/9/25
- Sensor-Surface: 3mm (Mechanical Surface Detection)
- Electronics: DAE4 Sn778; Calibrated: 2019/5/21
- Phantom: Twin-SAM V5.0 (30deg probe tilt); Type: QD 000 P40 CD; Serial: 1885
- Measurement SW: DASY52, Version 52.10 (2); SEMCAD X Version 14.6.12 (7450)

**Pin=250mW/Area Scan (71x71x1):** Interpolated grid: dx=1.200 mm, dy=1.200 mm  
 Maximum value of SAR (interpolated) = 19.7 W/kg

**Pin=250mW/Zoom Scan (7x7x7)/Cube 0:** Measurement grid: dx=5mm, dy=5mm, dz=5mm

Reference Value = 101.3 V/m; Power Drift = 0.04 dB

Peak SAR (extrapolated) = 31.0 W/kg

**SAR(1 g) = 14 W/kg; SAR(10 g) = 6.19 W/kg**

Maximum value of SAR (measured) = 18.9 W/kg

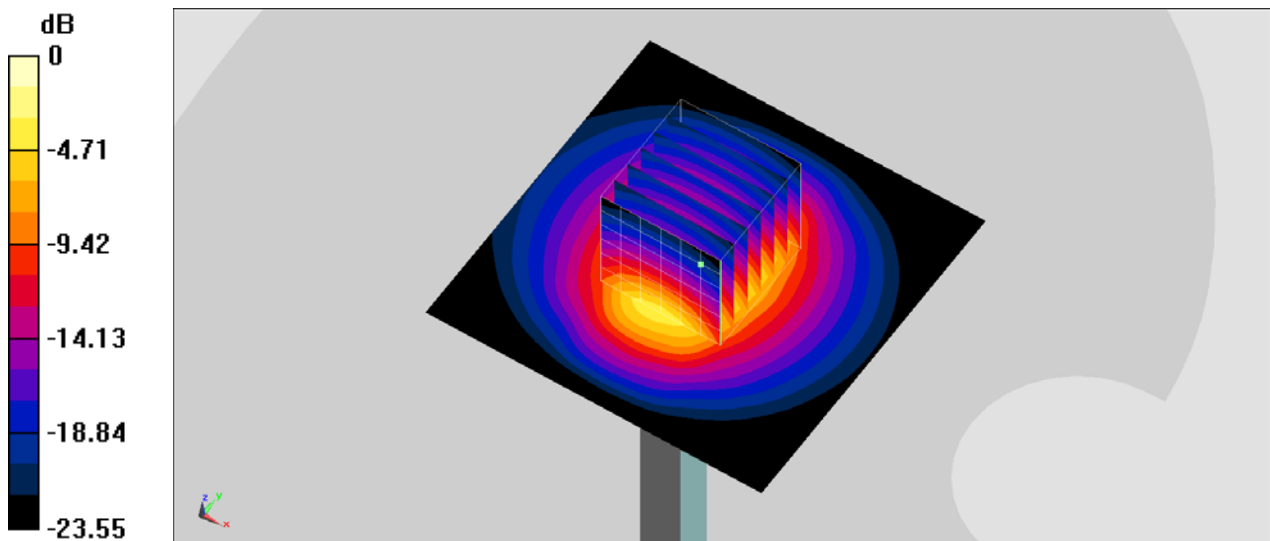

0 dB = 18.9 W/kg = 12.76 dBW/kg