



FCC RF Test Report

APPLICANT : Motorola Mobility LLC
EQUIPMENT : Mobile Cellular Phone
BRAND NAME : Motorola
MODEL NAME : XT2063-2
FCC ID : IHDT56YU1
STANDARD : 47 CFR Part 2, 24(E), 27(M), 27(N), 27(F)
CLASSIFICATION : PCS Licensed Transmitter Held to Ear (PCE)

The product was received on Jan. 22, 2020 and completely tested on May 21, 2020. We, Sporton International (Kunshan) Inc., would like to declare that the tested sample has been evaluated in accordance with the procedures given in ANSI C63.26-2015 and shown compliance with the applicable technical standards.

The test results in this report apply exclusively to the tested model / sample. Without written approval of Sporton International (Kunshan) Inc., the test report shall not be reproduced except in full.

Jason Jia

Reviewed by: Jason Jia / Supervisor

James Huang

Approved by: James Huang / Manager



Sporton International (Kunshan) Inc.

No. 1098, Pengxi North Road, Kunshan Economic Development Zone Jiangsu Province 215300
People's Republic of China



TABLE OF CONTENTS

REVISION HISTORY... 3
SUMMARY OF TEST RESULT ... 4
1 GENERAL DESCRIPTION ... 6
1.1 Applicant ... 6
1.2 Manufacturer ... 6
1.3 Product Feature of Equipment Under Test ... 6
1.4 Product Specification of Equipment Under Test ... 7
1.5 Modification of EUT ... 7
1.6 Maximum ERP/EIRP Power, Frequency Tolerance, and Emission Designator ... 8
1.7 Specification of Accessory ... 11
1.8 Testing Location ... 11
1.9 Test Software ... 11
1.10 Applicable Standards ... 12
2 TEST CONFIGURATION OF EQUIPMENT UNDER TEST ... 13
2.1 Test Mode ... 13
2.2 Connection Diagram of Test System ... 16
2.3 Support Unit used in test configuration and system ... 16
2.4 Measurement Results Explanation Example ... 17
2.5 Frequency List of Low/Middle/High Channels ... 18
3 CONDUCTED TEST ITEMS ... 21
3.1 Measuring Instruments ... 21
3.2 Test Setup ... 21
3.3 Test Result of Conducted Test ... 21
3.4 Conducted Output Power and ERP/EIRP ... 22
3.5 Peak-to-Average Ratio ... 23
3.6 Occupied Bandwidth ... 24
3.7 Conducted Band Edge ... 25
3.8 Conducted Spurious Emission ... 27
3.9 Frequency Stability ... 28
4 RADIATED TEST ITEMS ... 29
4.1 Measuring Instruments ... 29
4.2 Test Setup ... 29
4.3 Test Result of Radiated Test ... 29
4.4 Radiated Spurious Emission ... 30
5 LIST OF MEASURING EQUIPMENT ... 31
6 UNCERTAINTY OF EVALUATION ... 32
APPENDIX A. TEST RESULTS OF CONDUCTED TEST
APPENDIX B. TEST RESULTS OF RADIATED TEST
APPENDIX C. TEST SETUP PHOTOGRAPHS



REVISION HISTORY

REPORT NO.	VERSION	DESCRIPTION	ISSUED DATE
FG010812-01B	Rev. 01	Initial issue of report	Jun. 10, 2020



SUMMARY OF TEST RESULT

Report Section	FCC Rule	Description	Limit	Result	Remark
3.4	§2.1046	Conducted Output Power	Reporting Only	PASS	-
	§27.50(b)(10)	Effective Radiated Power (Band 13) (Band 71)	ERP < 3 Watt	PASS	-
	§24.232(c) §27.50(h)(2)	Equivalent Isotropic Radiated Power (Band 25)(Band 41)	EIRP < 2Watt	PASS	-
3.5	§24.232(d)	Peak-to-Average Ratio	<13 dB	PASS	-
3.6	§2.1049	Occupied Bandwidth	Reporting Only	PASS	-
3.7	§2.1051 §24.238(a) §27.53(c)(2)(4)	Conducted Band Edge Measurement (Band 13) (Band 25) (Band 71)	< 43+10log ₁₀ (P[Watts])	PASS	-
	§27.53(m)(4)	Conducted Band Edge Measurement (Band 41)	§27.53(m)(4)		
3.8	§2.1051 §24.238(a) §27.53(c)(2)	Conducted Spurious Emission (Band 13) (Band 25) (Band 71)	< 43+10log ₁₀ (P[Watts])	PASS	-
	§2.1051 §27.53(m)(4)	Conducted Spurious Emission (Band 41)	< 55+10log ₁₀ (P[Watts])		
3.9	§2.1055 §22.355	Frequency Stability Temperature & Voltage	< 2.5 ppm for Part 22H	PASS	-
	§2.1055 §24.235 §27.54		Within Authorized Band		



Report Section	FCC Rule	Description	Limit	Result	Remark
4.4	§2.1053 §24.238(a) §27.53(c)(2) §27.53(f)	Radiated Spurious Emission (Band 13) (Band 25) (Band 71)	$< 43+10\log_{10}(P[\text{Watts}])$	PASS	Under limit 24.64 dB at 1559.500 MHz
	§2.1053 §27.53(m)(4)	Radiated Spurious Emission (Band 41)	$< 55+10\log_{10}(P[\text{Watts}])$		

Declaration of Conformity:
The test results with all measurement uncertainty excluded are presented in accordance with the regulation limits or requirements declared by manufacturers.

Comments and Explanations:
The declared of product specification for EUT presented in the report are provided by the manufacturer, and the manufacturer takes all the responsibilities for the accuracy of product specification.



1 General Description

1.1 Applicant

Motorola Mobility LLC
222 W,Merchandise Mart Plaza, Chicago IL 60654 USA

1.2 Manufacturer

Motorola Mobility LLC
222 W,Merchandise Mart Plaza, Chicago IL 60654 USA

1.3 Product Feature of Equipment Under Test

Product Feature	
Equipment	Mobile Cellular Phone
Brand Name	Motorola
Model Name	XT2063-2
FCC ID	IHDT56YU1
EUT supports Radios application	CDMA/GSM/WCDMA/LTE/5G NR/NFC WLAN 2.4GHz 802.11b/g/n HT20 WLAN 5GHz 802.11 a/n HT20/HT40 WLAN 5GHz 802.11ac VHT20/VHT40/VHT80 Bluetooth BR/EDR/LE FM Receiver/GNSS
IMEI Code	Conducted/ Radiation: 351612110006159
HW Version	PVT1
SW Version	QPD30.102
EUT Stage	Identical Prototype



1.4 Product Specification of Equipment Under Test

Standards-related Product Specification	
Tx Frequency	LTE Band 13 : 779.5 MHz ~ 784.5 MHz LTE Band 25 : 1850.7MHz ~ 1914.3 MHz LTE Band 41 : 2498.5 MHz ~ 2687.5 MHz LTE Band 71: 665.5 MHz ~ 695.5MHz
Rx Frequency	LTE Band 13 : 748.5 MHz ~ 753.5 MHz LTE Band 25 : 1930.7MHz ~ 1994.3 MHz LTE Band 41 : 2498.5 MHz ~ 2687.5 MHz LTE Band 71: 619.5 MHz ~ 649.5MHz
Bandwidth	LTE Band 13 : 5MHz / 10MHz LTE Band 25 : 1.4MHz / 3MHz / 5MHz / 10MHz / 15MHz / 20MHz LTE Band 41 : 5MHz / 10MHz / 15MHz / 20MHz LTE Band 71 : 5MHz / 10MHz / 15MHz / 20MHz
Maximum Output Power to Antenna	LTE Band 13 : 22.57 dBm LTE Band 25 : 22.92 dBm LTE Band 41 : 26.30 dBm; Band 41C: 23.96 dBm LTE Band 71 : 23.22 dBm
Antenna Gain	LTE Band 13 : -2.34 dBi LTE Band 25 : 1.32 dBi LTE Band 41 : 3.02 dBi LTE Band 71 : -1.72 dBi
Type of Modulation	QPSK / 16QAM / 64QAM

Note: Only LTE Band 41 supports HPUE.

1.5 Modification of EUT

No modifications are made to the EUT during all test items.



1.6 Maximum ERP/EIRP Power, Frequency Tolerance, and Emission Designator

LTE Band 13		QPSK			16QAM		
BW (MHz)	Frequency Range (MHz)	Emission Designator (99%OBW)	Frequency Tolerance (ppm)	Maximum ERP(W)	Emission Designator (99%OBW)	Frequency Tolerance (ppm)	Maximum ERP(W)
5	779.5 ~ 784.5	4M51G7D	-	0.0625	4M49W7D	-	0.0637
10	782.0	9M01G7D	0.0033	0.0643	8M95W7D	-	0.0619
LTE Band 13		64QAM					
BW (MHz)	Frequency Range (MHz)	Emission Designator (99%OBW)	Frequency Tolerance (ppm)	Maximum ERP(W)			
5	779.5 ~ 784.5	4M50W7D	-	0.0484			
10	782.0	8M97W7D	-	0.0509			

LTE Band 25		QPSK			16QAM		
BW (MHz)	Frequency Range (MHz)	Emission Designator (99%OBW)	Frequency Tolerance (ppm)	Maximum EIRP(W)	Emission Designator (99%OBW)	Frequency Tolerance (ppm)	Maximum EIRP(W)
1.4	1850.7 ~ 1914.3	1M09G7D	-	0.2291	1M09W7D	-	0.2472
3	1851.5 ~ 1913.5	2M72G7D	-	0.2350	2M73W7D	-	0.2512
5	1852.5 ~ 1912.5	4M52G7D	-	0.2388	4M51W7D	-	0.2472
10	1855.0 ~ 1910.0	9M03G7D	0.0047	0.2377	9M07W7D	-	0.2512
15	1857.5 ~ 1907.5	13M5G7D	-	0.2495	13M4W7D	-	0.2495
20	1860.0 ~ 1905.0	18M4G7D	-	0.2655	18M5W7D	-	0.2495
LTE Band 25		64QAM					
BW (MHz)	Frequency Range (MHz)	Emission Designator (99%OBW)	Frequency Tolerance (ppm)	Maximum EIRP(W)			
1.4	1850.7 ~ 1914.3	1M09W7D	-	0.2009			
3	1851.5 ~ 1913.5	2M74W7D	-	0.2080			
5	1852.5 ~ 1912.5	4M49W7D	-	0.2042			
10	1855.0 ~ 1910.0	9M01W7D	-	0.2037			
15	1857.5 ~ 1907.5	13M4W7D	-	0.2113			
20	1860.0 ~ 1905.0	18M3W7D	-	0.2099			



LTE Band 71		QPSK			16QAM		
BW (MHz)	Frequency Range (MHz)	Emission Designator (99%OBW)	Frequency Tolerance (ppm)	Maximum ERP(W)	Emission Designator (99%OBW)	Frequency Tolerance (ppm)	Maximum ERP(W)
5	665.5 ~ 695.5	4M49G7D	-	0.0807	4M50W7D	-	0.0822
10	668.0 ~ 693.0	9M07G7D	0.0038	0.0798	9M05W7D	-	0.0836
15	670.5 ~ 690.5	13M5G7D	-	0.0826	13M4W7D	-	0.0855
20	673.0 ~ 688.0	17M9G7D	-	0.0861	17M9W7D	-	0.0859
LTE Band 71		64QAM					
BW (MHz)	Frequency Range (MHz)	Emission Designator (99%OBW)	Frequency Tolerance (ppm)		Maximum ERP(W)		
5	665.5 ~ 695.5	4M49W7D	-		0.0729		
10	668.0 ~ 693.0	9M03W7D	-		0.0710		
15	670.5 ~ 690.5	13M5W7D	-		0.0760		
20	673.0 ~ 688.0	17M9W7D	-		0.0743		

LTE Band 41		QPSK			16QAM		
BW (MHz)	Frequency Range (MHz)	Emission Designator (99%OBW)	Frequency Tolerance (ppm)	Maximum EIRP(W)	Emission Designator (99%OBW)	Frequency Tolerance (ppm)	Maximum EIRP(W)
5	2498.5 ~ 2687.5	4M50G7D	-	0.8414	4M50W7D	-	0.8511
10	2501.0 ~ 2685.0	9M11G7D	0.0022	0.8414	9M03W7D	-	0.8433
15	2503.5 ~ 2682.5	13M5G7D	-	0.8511	13M5W7D	-	0.8204
20	2506.0 ~ 2680.0	18M3G7D	-	0.8551	18M3W7D	-	0.7638
LTE Band 41		64QAM					
BW (MHz)	Frequency Range (MHz)	Emission Designator (99%OBW)	Frequency Tolerance (ppm)		Maximum EIRP(W)		
5	2498.5 ~ 2687.5	4M51W7D	-		0.7063		
10	2501.0 ~ 2685.0	9M05W7D	-		0.7295		
15	2503.5 ~ 2682.5	13M5W7D	-		0.7194		
20	2506.0 ~ 2680.0	18M5W7D	-		0.6109		



LTE Band 41 CA	QPSK			16QAM		
BW (MHz)	Emission Designator (99%OBW)	Frequency Tolerance (ppm)	Maximum EIRP(W)	Emission Designator (99%OBW)	Frequency Tolerance (ppm)	Maximum EIRP(W)
5MHz+20MHz	23M4G7D	-	0.4550	23M4W7D	-	0.4624
10MHz+15MHz	23M4G7D	-	0.4989	23M4W7D	-	0.4943
10MHz+20MHz	27M9G7D	-	0.4864	28M0W7D	-	0.4624
15MHz+10MHz	23M5G7D	-	0.4550	23M5W7D	-	0.4721
15MHz+15MHz	28M7G7D	-	0.4710	28M6W7D	-	0.4539
15MHz+20MHz	33M0G7D	-	0.4898	32M7W7D	-	0.4753
20MHz+5MHz	23M4G7D	-	0.4426	23M5W7D	-	0.4519
20MHz+10MHz	28M2G7D	-	0.4775	28M4W7D	-	0.4742
20MHz+15MHz	32M9G7D	-	0.4955	32M7W7D	-	0.4786
20MHz+20MHz	37M6G7D	0.0300	0.4898	37M4W7D	-	0.4909
LTE Band 41 CA	64QAM					
BW (MHz)	Emission Designator (99%OBW)	Frequency Tolerance (ppm)		Maximum EIRP(W)		
5MHz+20MHz	23M1W7D	-		0.4613		
10MHz+15MHz	23M5W7D	-		0.4677		
10MHz+20MHz	28M1W7D	-		0.4550		
15MHz+10MHz	23M4W7D	-		0.4645		
15MHz+15MHz	28M7W7D	-		0.4710		
15MHz+20MHz	32M8W7D	-		0.4487		
20MHz+5MHz	23M4W7D	-		0.4581		
20MHz+10MHz	28M2W7D	-		0.4519		
20MHz+15MHz	33M0W7D	-		0.4457		
20MHz+20MHz	37M7W7D	-		0.4710		



1.7 Specification of Accessory

Specification of Accessory				
AC Adapter 1	Brand Name	Motorola (Chenyang)	Model Name	SC-51
AC Adapter 2	Brand Name	Motorola (Acbel)	Model Name	SC-51
Battery	Brand Name	Motorola(ATL)	Model Name	LR50
USB Cable 1	Brand Name	Motorola (Sai bao)	Model Name	SC18C24367
USB Cable 2	Brand Name	Motorola (Luxshare)	Model Name	SC18C24368

1.8 Testing Location

Sporton International (Kunshan) Inc. is accredited to ISO/IEC 17025:2017 by American Association for Laboratory Accreditation with Certificate Number 5145.02.

Test Firm	Sporton International (Kunshan) Inc.		
Test Site Location	No. 1098, Pengxi North Road, Kunshan Economic Development Zone Jiangsu Province 215300 People's Republic of China TEL : +86-512-57900158 FAX : +86-512-57900958		
Test Site No.	Sporton Site No.	FCC Designation No.	FCC Test Firm Registration No.
	03CH04-KS TH01-KS	CN1257	314309

1.9 Test Software

Item	Site	Manufacture	Name	Version
1.	03CH04-KS	AUDIX	E3	6.2009-8-24al



1.10 Applicable Standards

According to the specifications of the manufacturer, the EUT must comply with the requirements of the following standards:

- ♦ 47 CFR Part 2, 24(E), 27(M), 27(N), 27(F)
- ♦ ANSI C63.26-2015
- ♦ FCC KDB 971168 D01 Power Meas License Digital Systems v03r01
- ♦ FCC KDB 412172 D01 Determining ERP and EIRP v01r01

Remark:

1. All test items were verified and recorded according to the standards and without any deviation during the test.
2. This EUT has also been tested and complied with the requirements of FCC Part 15, Subpart B, recorded in a separate test report.



2 Test Configuration of Equipment Under Test

2.1 Test Mode

Antenna port conducted and radiated test items listed below are performed according to KDB 971168 D01 Power Meas License Digital Systems v03r01 with maximum output power.

Radiated measurements are performed by rotating the EUT in three different orthogonal test planes to find the maximum emission.

Test Items	Band	Bandwidth (MHz)						Modulation			RB #			Test Channel		
		1.4	3	5	10	15	20	QPSK	16QAM	64QAM	1	Half	Full	L	M	H
Max. Output Power	13	-	-	v	v	-	-	v	v	v	v	v	v	v	v	v
	25	v	v	v	v	v	v	v	v	v	v	v	v	v	v	v
	41	-	-	v	v	v	v	v	v	v	v	v	v	v	v	v
	71	-	-	v	v	v	v	v	v	v	v	v	v	v	v	v
Peak-to-Average Ratio	13	-	-		v	-	-	v	v	v	v		v	v	v	v
	25						v	v	v	v	v		v	v	v	v
	41	-	-				v	v	v	v	v		v	v	v	v
	71	-	-				v	v	v	v	v		v	v	v	v
26dB and 99% Bandwidth	13	-	-	v	v	-	-	v	v	v			v	v	v	v
	25	v	v	v	v	v	v	v	v	v			v	v	v	v
	41	-	-	v	v	v	v	v	v	v			v	v	v	v
	71	-	-	v	v	v	v	v	v	v			v	v	v	v
Conducted Band Edge	13	-	-	v	v	-	-	v	v	v	v		v	v		v
	25	v	v	v	v	v	v	v	v	v	v		v	v		v
	41	-	-	v	v	v	v	v	v	v	v		v	v		v
	71	-	-	v	v	v	v	v	v	v	v		v	v		v



Test Items	Band	Bandwidth (MHz)						Modulation			RB #			Test Channel		
		1.4	3	5	10	15	20	QPSK	16QAM	64QAM	1	Half	Full	L	M	H
Conducted Spurious Emission	13	-	-	v	v	-	-	v	v	v	v			v	v	v
	25	v	v	v	v	v	v	v	v	v	v			v	v	v
	41	-	-	v	v	v	v	v	v	v	v			v	v	v
	71	-	-	v	v	v	v	v	v	v	v			v	v	v
Frequency Stability	13	-	-		v	-	-	v					v		v	
	25				v			v					v		v	
	41	-	-		v			v					v		v	
	71	-	-		v			v					v		v	
E.R.P / E.I.R.P	13	-	-	v	v	-	-	v	v	v	v			v	v	v
	25	v	v	v	v	v	v	v	v	v	v			v	v	v
	41	-	-	v	v	v	v	v	v	v	v			v	v	v
	71	-	-	v	v	v	v	v	v	v	v			v	v	v
Radiated Spurious Emission	13	Worst Case											v	v	v	
	25	Worst Case											v	v	v	
	41	Worst Case											v	v	v	
	71	Worst Case											v	v	v	
Note	<ol style="list-style-type: none"> The mark "v" means that this configuration is chosen for testing The mark "-" means that this bandwidth is not supported. The device is investigated from 30MHz to 10 times of fundamental signal for radiated spurious emission test under different RB size/offset and modulations in exploratory test. Subsequently, only the worst case emissions are reported. 															



Test Items	Band	Bandwidth (MHz)										Modulation			RB #			Test Channel				
		20+20	20+15	15+20	20+10	10+20	20+5	5+20	15+15	15+10	10+15	QPSK	16QAM	64QAM	1	Half	Full	L	M	H		
Max. Output Power	41C_CA	v	v	v	v	v	v	v	v	v	v	v	v	v	v	v	v	v	v	v	v	
26dB and 99% Bandwidth	41C_CA	v	v	v	v	v	v	v	v	v	v	v	v	v	v	v			v	v	v	v
Conducted Band Edge	41C_CA	v	v	v	v	v	v	v	v	v	v	v	v	v	v	v		v	v		v	v
Conducted Spurious Emission	41C_CA	v	v	v	v	v	v	v	v	v	v	v	v	v	v	v				v	v	v
E.I.R.P.	41C_CA	v	v	v	v	v	v	v	v	v	v	v	v	v	v	v				v	v	v
Radiated Spurious Emission	41C_CA	Worst Case																v	v	v		
Note	<ol style="list-style-type: none"> The mark "v " means that this configuration is chosen for testing The mark "- " means that this bandwidth is not supported. The device is investigated from 30MHz to 10 times of fundamental signal for radiated spurious emission test under different RB size/offset and modulations in exploratory test. Subsequently, only the worst case emissions are reported. 																					

2.2 Connection Diagram of Test System

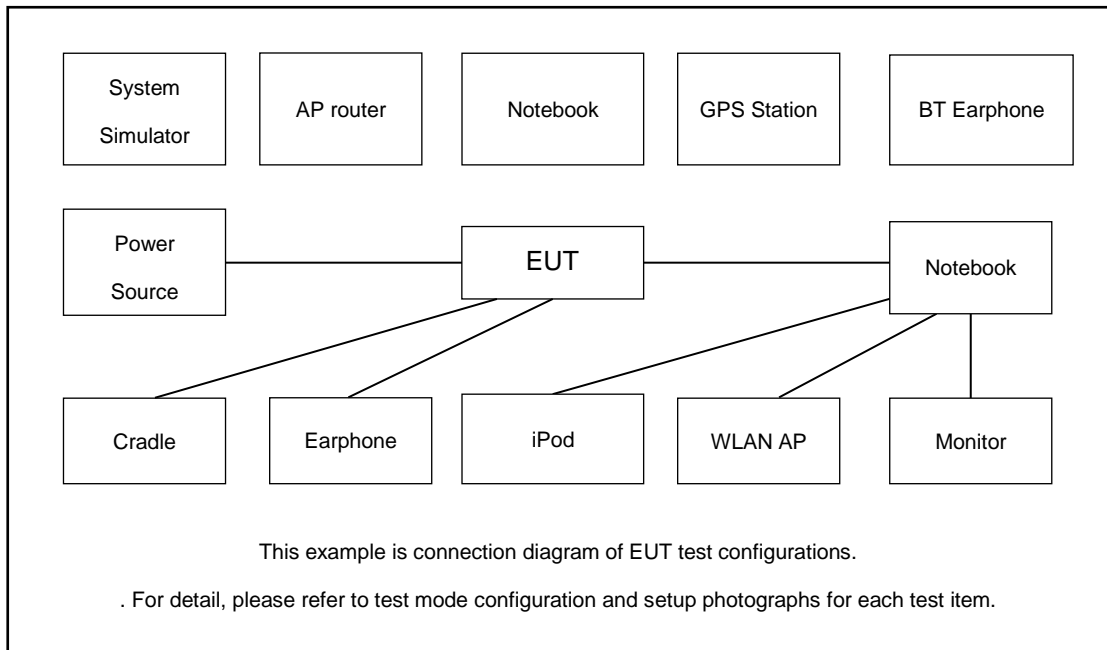

2.3 Support Unit used in test configuration and system

Item	Equipment	Trade Name	Model No.	FCC ID	Data Cable	Power Cord
1.	Power Supply	GWINSTEK	PSS-2002	N/A	N/A	Unshielded, 1.8m
2.	LTE Base Station	Anritsu	MT8820C	N/A	N/A	Unshielded, 1.8m
3.	Earphone	Moto	SH38C16618	N/A	Unshielded, 1.2m	N/A



2.4 Measurement Results Explanation Example

For all conducted test items:

The offset level is set in the spectrum analyzer to compensate the RF cable loss between EUT conducted output port and spectrum analyzer. With the offset compensation, the spectrum analyzer reading level is exactly the EUT RF output level.

The spectrum analyzer offset is derived from RF cable loss.

Offset = RF cable loss.

Following shows an offset computation example with cable loss 5.40 dB.

Example :

Offset(dB) = RF cable loss(dB).
= 5.40 (dB)



2.5 Frequency List of Low/Middle/High Channels

LTE Band 13 Channel and Frequency List				
BW [MHz]	Channel/Frequency(MHz)	Lowest	Middle	Highest
10	Channel	-	23230	-
	Frequency	-	782	-
5	Channel	23205	23230	23255
	Frequency	779.5	782	784.5

LTE Band 25 Channel and Frequency List				
BW [MHz]	Channel/Frequency(MHz)	Lowest	Middle	Highest
20	Channel	26140	26340	26590
	Frequency	1860	1880	1905
15	Channel	26115	26340	26615
	Frequency	1857.5	1880	1907.5
10	Channel	26090	26340	26640
	Frequency	1855	1880	1910
5	Channel	26065	26340	26665
	Frequency	1852.5	1880	1912.5
3	Channel	26055	26340	26675
	Frequency	1851.5	1880	1913.5
1.4	Channel	26047	26340	26683
	Frequency	1850.7	1880	1914.3

LTE Band 41 Channel and Frequency List				
BW [MHz]	Channel/Frequency(MHz)	Lowest	Middle	Highest
20	Channel	39750	40620	41490
	Frequency	2506	2593	2680
15	Channel	39725	40620	41515
	Frequency	2503.5	2593	2682.5
10	Channel	39700	40620	41540
	Frequency	2501	2593	2685
5	Channel	39675	40620	41565
	Frequency	2498.5	2593	2687.5



LTE Band 71 Channel and Frequency List				
BW [MHz]	Channel/Frequency(MHz)	Lowest	Middle	Highest
20	Channel	133222	133322	133372
	Frequency	673.0	680.5	688.0
15	Channel	133197	133297	133397
	Frequency	670.5	680.5	690.5
10	Channel	133172	133272	133422
	Frequency	668.0	678.0	693.0
5	Channel	133147	133247	133447
	Frequency	665.5	675.5	695.5

LTE Band 41C_CA Channel and Frequency List					
BW [MHz]	Channel/Frequency(MHz)	Lowest	Middle	Highest	
20 + 20	PCC	Channel	39750	40521	41292
		Frequency	2506.0	2583.1	2660.2
	SCC	Channel	39948	40719	41490
		Frequency	2525.8	2602.9	2680.0
20 + 15	PCC	Channel	39750	40546	41341
		Frequency	2506.0	2585.6	2665.1
	SCC	Channel	39921	40717	41512
		Frequency	2523.1	2602.7	2682.2
15 + 20	PCC	Channel	39728	40523	41319
		Frequency	2503.8	2593.3	2662.9
	SCC	Channel	39899	40694	41490
		Frequency	2520.9	2600.4	2680.0
20 + 10	PCC	Channel	39750	40571	41391
		Frequency	2506.0	2588.1	2670.1
	SCC	Channel	39894	40715	41535
		Frequency	2520.4	2602.5	2684.5
10 + 20	PCC	Channel	39705	40526	41346
		Frequency	2501.5	2583.6	2665.6
	SCC	Channel	39849	40670	41490
		Frequency	2515.9	2598.0	2680.0



LTE Band 41C_CA Channel and Frequency List					
20 + 5	PCC	Channel	39750	40595	41440
		Frequency	2506.0	2590.5	2675.0
	SCC	Channel	39867	40712	41557
		Frequency	2517.7	2602.2	2686.7
5 + 20	PCC	Channel	39683	40528	41373
		Frequency	2499.3	2583.8	2668.3
	SCC	Channel	39800	40645	41490
		Frequency	2511.0	2595.5	2680.0
15 + 15	PCC	Channel	39725	40545	41365
		Frequency	2503.5	2585.5	2667.5
	SCC	Channel	39875	40695	41515
		Frequency	2518.5	2600.5	2682.5
10 + 15	PCC	Channel	39703	40549	41395
		Frequency	2501.3	2585.9	2670.5
	SCC	Channel	39823	40669	41515
		Frequency	2513.3	2597.9	2682.5
15 + 10	PCC	Channel	39725	40571	41417
		Frequency	2503.5	2588.1	2672.7
	SCC	Channel	39845	40691	41537
		Frequency	2515.5	2600.1	2684.7

3 Conducted Test Items

3.1 Measuring Instruments

See list of measuring instruments of this test report.

3.2 Test Setup

3.2.1 Conducted Output Power

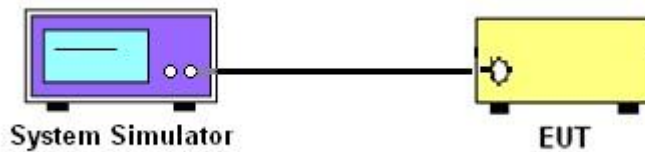

3.2.2 Peak-to-Average Ratio, Occupied Bandwidth ,Conducted Band-Edge and Conducted Spurious Emission

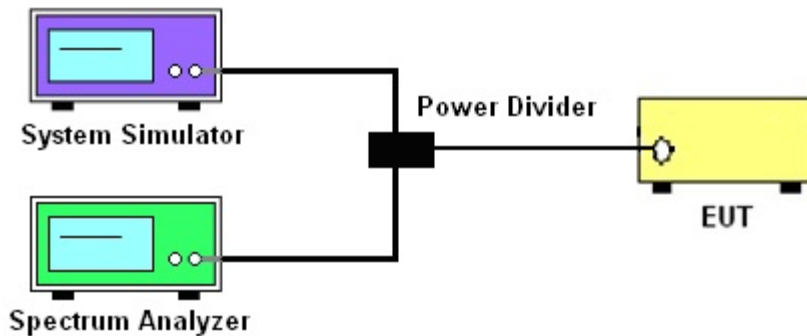

3.2.3 Frequency Stability

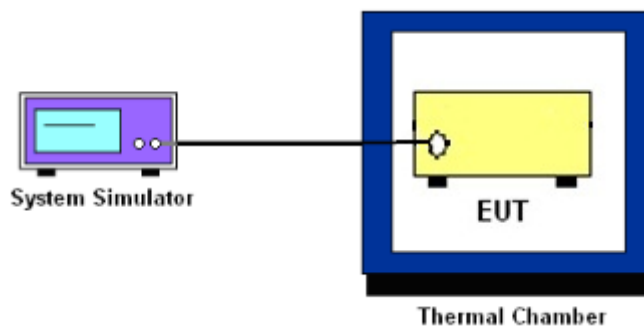

3.3 Test Result of Conducted Test

Please refer to Appendix A.



3.4 Conducted Output Power and ERP/EIRP

3.4.1 Description of the Conducted Output Power Measurement and ERP/EIRP Measurement

A system simulator was used to establish communication with the EUT. Its parameters were set to force the EUT transmitting at maximum output power. The measured power in the radio frequency on the transmitter output terminals shall be reported.

The ERP of mobile transmitters must not exceed 7 Watts for LTE Band 5 and Band 26.

The ERP of mobile transmitters must not exceed 3 Watts for LTE Band 12, Band 13 and Band 17 and Band 71.

The EIRP of mobile transmitters must not exceed 2 Watts for LTE Band 2 and Band 25 and Band 7 and Band 38 and Band 41.

The EIRP of mobile transmitters must not exceed 1 Watts for LTE Band 4 and Band 66.

According to KDB 412172 D01 Power Approach,

$EIRP = P_T + G_T - L_C$, $ERP = EIRP - 2.15$, where

P_T = transmitter output power in dBm

G_T = gain of the transmitting antenna in dBi

L_C = signal attenuation in the connecting cable between the transmitter and antenna in dB

3.4.2 Test Procedures

1. The testing follows ANSI C63.26 Section 5.2
2. The transmitter output port was connected to the system simulator.
3. Set EUT at maximum power through the system simulator.
4. Select lowest, middle, and highest channels for each band and different modulation.
5. Measure and record the power level from the system simulator.



3.5 Peak-to-Average Ratio

3.5.1 Description of the PAR Measurement

Power Complementary Cumulative Distribution Function (CCDF) curves provide a means for characterizing the power peaks of a digitally modulated signal on a statistical basis. A CCDF curve depicts the probability of the peak signal amplitude exceeding the average power level. Most contemporary measurement instrumentation include the capability to produce CCDF curves for an input signal provided that the instrument's resolution bandwidth can be set wide enough to accommodate the entire input signal bandwidth. In measuring transmissions in this band using an average power technique, the peak-to-average ratio (PAR) of the transmission may not exceed 13 dB.

3.5.2 Test Procedures

1. The testing follows ANSI C63.26 Section 5.2.3.4 (CCDF).
2. The EUT was connected to spectrum and system simulator via a power divider.
3. Set the CCDF (Complementary Cumulative Distribution Function) option in spectrum analyzer.
4. The highest RF powers were measured and recorded the maximum PAPR level associated with a probability of 0.1 %.
5. Record the deviation as Peak to Average Ratio.



3.6 Occupied Bandwidth

3.6.1 Description of Occupied Bandwidth Measurement

The occupied bandwidth is the width of a frequency band such that, below the lower and above the upper frequency limits, the mean powers emitted are each equal to a specified percentage 0.5% of the total mean transmitted power.

The 26 dB emission bandwidth is defined as the frequency range between two points, one above and one below the carrier frequency, at which the spectral density of the emission is attenuated 26 dB below the maximum in-band spectral density of the modulated signal. Spectral density (power per unit bandwidth) is to be measured with a detector of resolution bandwidth equal to approximately 1.0% of the emission bandwidth.

3.6.2 Test Procedures

1. The testing follows ANSI C63.26 Section 5.4
2. The EUT was connected to spectrum analyzer and system simulator via a power divider.
3. The spectrum analyzer center frequency is set to the nominal EUT channel center frequency. The span range for the spectrum analyzer shall be between two and five times the anticipated OBW.
4. The nominal resolution bandwidth (RBW) shall be in the range of 1 to 5 % of the anticipated OBW, and the VBW shall be at least 3 times the RBW.
5. Set the detection mode to peak, and the trace mode to max hold.
6. Determine the reference value: Set the EUT to transmit a modulated signal. Allow the trace to stabilize. Set the spectrum analyzer marker to the highest level of the displayed trace.
(this is the reference value)
7. Determine the “-26 dB down amplitude” as equal to (Reference Value – X).
8. Place two markers, one at the lowest and the other at the highest frequency of the envelope of the spectral display such that each marker is at or slightly below the “-X dB down amplitude” determined in step 6. If a marker is below this “-X dB down amplitude” value it shall be placed as close as possible to this value. The OBW is the positive frequency difference between the two markers.
9. Use the 99 % power bandwidth function of the spectrum analyzer and report the measured bandwidth.



3.7 Conducted Band Edge

3.7.1 Description of Conducted Band Edge Measurement

24.238 (a)

For operations in the 1850-1910 and 1930-1990 MHz band, the FCC limit is $43 + 10\log_{10}(P[\text{Watts}])$ dB below the transmitter power $P(\text{Watts})$ in a 1MHz bandwidth. However, in the 1 MHz bands immediately outside and adjacent to the frequency block a resolution bandwidth of at least one percent of the emission bandwidth of the fundamental emission of the transmitter may be employed.

27.53 (c)

For operations in the 776-788 MHz band, the FCC limit is $43 + 10\log_{10}(P[\text{Watts}])$ dB below the transmitter power $P(\text{Watts})$ in a 100 kHz bandwidth. However, in the 100 kHz bands immediately outside and adjacent to the frequency block, a resolution bandwidth of at least 30 kHz may be employed. In addition, the power of any unwanted emissions in any 6.25 kHz bandwidth for all frequencies between 763-775 MHz and 793-806 MHz shall be attenuated below the transmitter power, P (dBW), by at least $65 + 10 \log_{10} p(\text{watts})$, dB, for mobile and portable equipment.

27.53 (g)

For operations in the 600MHz band and 698 -746 MHz band, the FCC limit is $43 + 10\log_{10}(P[\text{Watts}])$ dB below the transmitter power $P(\text{Watts})$ in a 100 kHz bandwidth. However, in the 100 kilohertz bands immediately outside and adjacent to a licensee's frequency block, a resolution bandwidth of at least 30 kHz may be employed.

27.53(m)(4)

For mobile digital stations, the attenuation factor shall be not less than $40 + 10 \log (P)$ dB on all frequencies between the channel edge and 5 megahertz from the channel edge, $43 + 10 \log (P)$ dB on all frequencies between 5 megahertz and X megahertz from the channel edge, and $55 + 10 \log (P)$ dB on all frequencies more than X megahertz from the channel edge, where X is the greater of 6 megahertz or the actual emission bandwidth as defined in paragraph (m)(6) of this section. In addition, the attenuation factor shall not be less that $43 + 10 \log (P)$ dB on all frequencies between 2490.5 MHz and 2496 MHz and $55 + 10 \log (P)$ dB at or below 2490.5 MHz. Mobile Satellite Service licensees operating on frequencies below 2495 MHz may also submit a documented interference complaint against BRS licensees operating on channel BRS Channel 1 on the same terms and conditions as adjacent channel BRS or EBS licensees.



3.7.2 Test Procedures

1. The testing follows ANSI C63.26 section 5.7
2. The EUT was connected to spectrum analyzer and system simulator via a power divider.
3. The band edges of low and high channels for the highest RF powers were measured.
4. Set RBW \geq 1% EBW in the 1MHz band immediately outside and adjacent to the band edge.
5. Beyond the 1 MHz band from the band edge, RBW=1MHz was used or a narrower RBW was used and the measured power was integrated over the full required measurement bandwidth of 1 MHz.
6. Set spectrum analyzer with RMS detector.
7. Offset has included the duty factor for LTE Band 38/41. Duty factor = $10 \log (1/x)$, where x is the measured duty cycle
8. The RF fundamental frequency should be excluded against the limit line in the operating frequency band.
9. Checked that all the results comply with the emission limit line.

Example:

The limit line is derived from $43 + 10\log(P)$ dB below the transmitter power P(Watts)

$$= P(W) - [43 + 10\log(P)] \text{ (dB)}$$

$$= [30 + 10\log(P)] \text{ (dBm)} - [43 + 10\log(P)] \text{ (dB)} = -13\text{dBm}.$$

10. For LTE Band 41, the other 40 dB, and 55 dB have additionally applied same calculation above.



3.8 Conducted Spurious Emission

3.8.1 Description of Conducted Spurious Emission Measurement

The power of any emission outside of the authorized operating frequency ranges must be lower than the transmitter power (P) by a factor of at least $43 + 10 \log (P)$ dB.

For Band 41:

The power of any emission outside of the authorized operating frequency ranges must be lower than the transmitter power (P) by a factor of at least $55 + 10 \log (P)$ dB.

It is measured by means of a calibrated spectrum analyzer and scanned from 30 MHz up to a frequency including its 10th harmonic.

3.8.2 Test Procedures

1. The testing follows ANSI C63.26 section 5.7
2. The EUT was connected to spectrum analyzer and system simulator via a power divider.
3. The RF output of EUT was connected to the spectrum analyzer by RF cable and attenuator. The path loss was compensated to the results for each measurement.
4. The middle channel for the highest RF power within the transmitting frequency was measured.
5. The conducted spurious emission for the whole frequency range was taken.
6. Make the measurement with the spectrum analyzer's RBW = 1MHz, VBW = 3MHz.
7. Set spectrum analyzer with RMS detector.
8. Offset has included the duty factor for LTE Band 38/41. Duty factor = $10 \log (1/x)$, where x is the measured duty cycle
9. Taking the record of maximum spurious emission.
10. The RF fundamental frequency should be excluded against the limit line in the operating frequency band.
11. The limit line is derived from $43 + 10 \log (P)$ dB below the transmitter power P(Watts)
= $P(W) - [43 + 10 \log (P)]$ (dB)
= $[30 + 10 \log (P)]$ (dBm) - $[43 + 10 \log (P)]$ (dB)
= -13dBm.
12. For Band 41
The limit line is derived from $55 + 10 \log (P)$ dB below the transmitter power P(Watts)
= $P(W) - [55 + 10 \log (P)]$ (dB)
= $[30 + 10 \log (P)]$ (dBm) - $[55 + 10 \log (P)]$ (dB)
= -25dBm.



3.9 Frequency Stability

3.9.1 Description of Frequency Stability Measurement

The frequency stability shall be measured by variation of ambient temperature and variation of primary supply voltage to ensure that the fundamental emission stays within the authorized frequency block. The frequency stability of the transmitter shall be maintained within $\pm 0.00025\%$ ($\pm 2.5\text{ppm}$) of the center frequency.

3.9.2 Test Procedures for Temperature Variation

1. The testing follows ANSI C63.26 section 5.6.4
2. The EUT was set up in the thermal chamber and connected with the system simulator.
3. With power OFF, the temperature was decreased to -30°C and the EUT was stabilized before testing. Power was applied and the maximum change in frequency was recorded within one minute.
4. With power OFF, the temperature was raised in 10°C step up to 50°C . The EUT was stabilized at each step for at least half an hour. Power was applied and the maximum frequency change was recorded within one minute.

3.9.3 Test Procedures for Voltage Variation

1. The testing follows ANSI C63.26 section 5.6.5
2. The EUT was placed in a temperature chamber at $20\pm 5^{\circ}\text{C}$ and connected with the system simulator.
3. The power supply voltage to the EUT was varied from 85% to 115% of the nominal value for other than hand carried battery equipment.
4. For hand carried, battery powered equipment, reduce the primary ac or dc supply voltage to the battery operating end point, which shall be specified by the manufacturer.
5. The variation in frequency was measured for the worst case.

4 Radiated Test Items

4.1 Measuring Instruments

See list of measuring instruments of this test report.

4.2 Test Setup

4.2.1 For radiated test from 30MHz to 1GHz

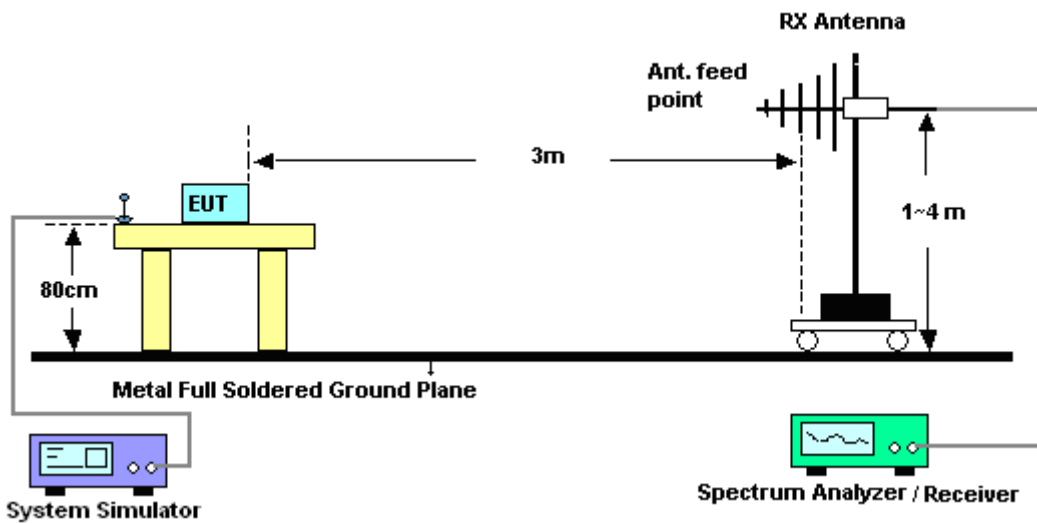

4.2.2 For radiated test above 1GHz

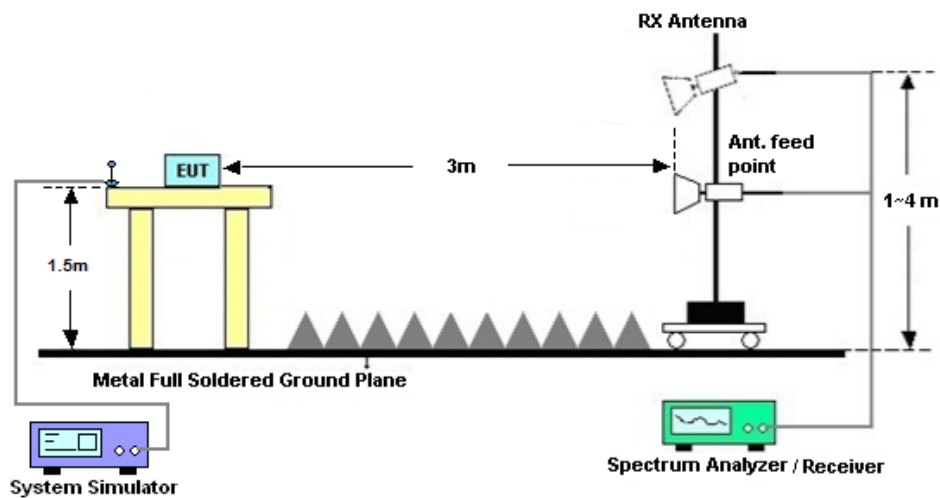

4.3 Test Result of Radiated Test

Please refer to Appendix B.



4.4 Radiated Spurious Emission

4.4.1 Description of Radiated Spurious Emission

The radiated spurious emission was measured by substitution method according to ANSI C63.26. The power of any emission outside of the authorized operating frequency ranges must be attenuated below the transmitter power (P) by a factor of at least $43 + 10 \log (P)$ dB.

For Band 7, 38, 41

The power of any emission outside of the authorized operating frequency ranges must be attenuated below the transmitter power (P) by a factor of at least $55 + 10 \log (P)$ dB.

For LTE Band 13

For operations in the 746-758 MHz, 775-788 MHz, and 805-806 MHz bands, emissions in the band 1559-1610 MHz shall be limited to -70 dBW/MHz equivalent isotropically radiated power (EIRP) for wideband signals, and -80 dBW EIRP for discrete emissions of less than 700 Hz bandwidth.

The spectrum is scanned from 30 MHz up to a frequency including its 10th harmonic.

4.4.2 Test Procedures

1. The testing follows ANSI C63.26 Section 5.5
2. The EUT was placed on a turntable with 0.8 meter height for frequency below 1GHz and 1.5 meter height for frequency above 1GHz respectively above ground.
3. The EUT was set 3 meters from the receiving antenna mounted on the antenna tower.
4. The table was rotated 360 degrees to determine the position of the highest spurious emission.
5. The height of the receiving antenna is varied between 1m to 4m to search the maximum spurious emission for both horizontal and vertical polarizations.
6. During the measurement, the system simulator parameters were set to force the EUT transmitting at maximum output power.
7. Make the measurement with the spectrum analyzer's RBW = 1MHz, VBW = 3MHz, taking the record of maximum spurious emission.
8. A horn antenna was substituted in place of the EUT and was driven by a signal generator.
9. Tune the output power of signal generator to the same emission level with EUT maximum spurious emission.
10. $EIRP (dBm) = S.G. Power - Tx Cable Loss + Tx Antenna Gain$
11. $ERP (dBm) = EIRP - 2.15$
12. The RF fundamental frequency should be excluded against the limit line in the operating frequency band.
The limit line is derived from $43 + 10\log(P)$ dB below the transmitter power P(Watts)
 $= P(W) - [43 + 10\log(P)] (dB)$
 $= [30 + 10\log(P)] (dBm) - [43 + 10\log(P)] (dB)$
 $= -13dBm.$
13. For Band 41:
The limit line is derived from $55 + 10\log(P)$ dB below the transmitter power P(Watts)



5 List of Measuring Equipment

Instrument	Manufacturer	Model No.	Serial No.	Characteristics	Calibration Date	Test Date	Due Date	Remark
Spectrum Analyzer	R&S	FSV30	101338	10Hz~30GHz	Apr. 14.2020	May 04, 2020~ May 22, 2020	Apr. 13, 2021	Conducted (TH01-KS)
Temperature & humidity chamber	Hongzhan	LP-150U	H2014011440	-40~+150°C 20%~95%RH	Jul. 04, 2019	May 04, 2020~ May 22, 2020	Jul. 03, 2020	Conducted (TH01-KS)
EXA Spectrum Analyzer	Keysight	N9010A	MY55150244	10Hz-44G,MAX 30dB	Apr. 15, 2020	May 21, 2020	Apr. 14, 2021	Radiation (03CH04-KS)
Bilog Antenna	TeseQ	CBL6111D	49922	30MHz-1GHz	May 30, 2019	May 21, 2020	May 29, 2020	Radiation (03CH04-KS)
Horn Antenna	Schwarzbeck	BBHA9120D	1356	1GHz~18GHz	Apr. 20, 2020	May 21, 2020	Apr. 19, 2021	Radiation (03CH04-KS)
SHF-EHF Horn	Com-power	AH-840	101115	18GHz~40GHz	Nov. 10, 2019	May 21, 2020	Nov. 09, 2020	Radiation (03CH04-KS)
Amplifier	SONOMA	310N	187289	9KHz-1GHz	Aug. 06, 2019	May 21, 2020	Aug. 05, 2020	Radiation (03CH04-KS)
Amplifier	MITEQ	EM18G40G GA	060728	18~40GHz	Jan. 08, 2020	May 21, 2020	Jan. 07, 2021	Radiation (03CH04-KS)
high gain Amplifier	MITEQ	AMF-7D-00 101800-30-1 0P	2025788	1Ghz-18Ghz	Aug. 16, 2019	May 21, 2020	Aug.15, 2020	Radiation (03CH04-KS)
Amplifier	Keysight	83017A	MY57280106	500MHz~26.5GHz	Oct.15, 2019	May 21, 2020	Oct. 14, 2020	Radiation (03CH04-KS)
AC Power Source	Chroma	61601	F104090004	N/A	NCR	May 21, 2020	NCR	Radiation (03CH04-KS)
Turn Table	ChamPro	EM 1000-T	060762-T	0~360 degree	NCR	May 21, 2020	NCR	Radiation (03CH04-KS)
Antenna Mast	ChamPro	EM 1000-A	060762-A	1 m~4 m	NCR	May 21, 2020	NCR	Radiation (03CH04-KS)

NCR: No Calibration Required



6 Uncertainty of Evaluation

The measurement uncertainties shown below were calculated in accordance with the requirements of ANSI 63.26-2015. All the measurement uncertainty value were shown with a coverage K=2 to indicate 95% level of confidence. The measurement data show herein meets or exceeds the CISPR measurement uncertainty values specified in CISPR 16-4-2 and can be compared directly to specified limit to determine compliance.

Uncertainty of Radiated Emission Measurement (30 MHz ~ 1000 MHz)

Measuring Uncertainty for a Level of Confidence of 95% (U = 2Uc(y))	3.3dB
---	-------

Uncertainty of Radiated Emission Measurement (1 GHz ~ 40 GHz)

Measuring Uncertainty for a Level of Confidence of 95% (U = 2Uc(y))	2.8dB
---	-------



Appendix A. Test Results of Conducted Test

Conducted Output Power(Average power)

LTE Band 13 Maximum Average Power [dBm]						
BW [MHz]	RB Size	RB Offset	Mod	Lowest	Middle	Highest
10	1	0	QPSK		22.57	
10	1	25			22.34	
10	1	49			22.33	
10	25	0			22.10	
10	25	12			22.05	
10	25	25			22.01	
10	50	0			22.08	
10	1	0	16-QAM	-	22.41	-
10	1	25			22.33	
10	1	49			22.24	
10	25	0			21.60	
10	25	12			21.77	
10	25	25			21.72	
10	50	0			21.77	
10	1	0	64-QAM		21.56	
10	1	25			21.55	
10	1	49			21.45	
10	25	0			20.67	
10	25	12			20.66	
10	25	25			20.76	
10	50	0			20.50	
5	1	0	QPSK	22.16	22.22	22.23
5	1	12		22.28	22.30	22.30
5	1	24		22.27	22.31	22.23
5	12	0		22.15	22.05	22.30
5	12	7		22.19	22.31	22.38
5	12	13		22.14	22.28	22.36
5	25	0		22.45	22.22	22.39
5	1	0	16-QAM	22.45	22.45	22.53



5	1	12		22.45	22.31	22.49
5	1	24		22.45	22.05	22.34
5	12	0		21.54	21.67	21.87
5	12	7		21.44	21.66	21.56
5	12	13		21.43	21.55	21.89
5	25	0		22.00	21.89	21.98
5	1	0	64-QAM	21.03	21.01	21.01
5	1	12		21.23	21.34	21.32
5	1	24		21.30	21.33	21.02
5	12	0		20.31	20.66	20.56
5	12	7		20.69	20.78	20.55
5	12	13		20.63	20.75	20.34
5	25	0		20.41	20.66	20.43



LTE Band 25 Maximum Average Power [dBm]						
BW [MHz]	RB Size	RB Offset	Mod	Lowest	Middle	Highest
20	1	0	QPSK	22.84	22.92	22.87
20	1	49		22.78	22.75	22.78
20	1	99		22.90	22.87	22.78
20	50	0		22.51	22.69	22.53
20	50	24		22.58	22.58	22.50
20	50	50		22.56	22.55	22.61
20	100	0		22.51	22.59	22.58
20	1	0	16-QAM	22.61	22.51	22.63
20	1	49		22.60	22.57	22.65
20	1	99		22.51	22.56	22.55
20	50	0		21.81	21.65	21.71
20	50	24		21.78	21.76	21.68
20	50	50		21.79	21.76	21.81
20	100	0		21.75	21.76	21.78
20	1	0	64-QAM	21.90	21.75	21.65
20	1	49		21.89	21.71	21.53
20	1	99		21.68	21.84	21.43
20	50	0		20.70	20.70	20.47
20	50	24		20.77	20.79	20.73
20	50	50		20.75	20.74	20.72
20	100	0		20.75	20.74	20.35
15	1	0	QPSK	22.47	22.52	22.49
15	1	37		22.51	22.40	22.54
15	1	74		22.42	22.39	22.45
15	36	0		22.58	22.57	22.55
15	36	20		22.64	22.63	22.63
15	36	39		22.55	22.60	22.63
15	75	0		22.55	22.59	22.65
15	1	0	16-QAM	22.60	22.52	22.55
15	1	37		22.65	22.59	22.57
15	1	74		22.59	22.52	22.55
15	36	0		21.84	21.66	21.87
15	36	20		21.93	21.82	21.87
15	36	39		21.77	21.81	21.82



15	75	0		21.84	21.83	21.84
15	1	0	64-QAM	21.85	21.81	21.45
15	1	37		21.89	21.93	21.73
15	1	74		21.86	21.77	21.46
15	36	0		20.70	20.77	20.69
15	36	20		20.83	20.78	20.81
15	36	39		20.74	20.79	20.79
15	75	0		20.85	20.81	20.54



LTE Band 25 Maximum Average Power [dBm]						
BW [MHz]	RB Size	RB Offset	Mod	Lowest	Middle	Highest
10	1	0	QPSK	22.20	22.09	22.12
10	1	25		22.44	22.17	22.22
10	1	49		22.25	22.20	22.27
10	25	0		22.34	22.24	22.25
10	25	12		22.41	22.39	22.39
10	25	25		22.35	22.27	22.40
10	50	0		22.42	22.40	22.29
10	1	0	16-QAM	22.66	22.63	22.68
10	1	25		22.51	22.62	22.62
10	1	49		22.58	22.64	22.58
10	25	0		21.55	21.52	21.50
10	25	12		21.59	21.59	21.58
10	25	25		21.62	21.66	21.64
10	50	0		21.60	21.51	21.52
10	1	0	64-QAM	21.66	21.62	21.59
10	1	25		21.75	21.61	21.70
10	1	49		21.75	21.77	21.44
10	25	0		20.62	20.49	20.46
10	25	12		20.60	20.63	20.60
10	25	25		20.64	20.63	20.58
10	50	0		20.52	20.62	20.53
5	1	0	QPSK	22.28	22.13	22.28
5	1	12		22.21	22.22	22.27
5	1	24		22.25	22.23	22.25
5	12	0		22.37	22.27	22.33
5	12	7		22.33	22.38	22.37
5	12	13		22.39	22.38	22.41
5	25	0		22.32	22.31	22.46
5	1	0	16-QAM	22.48	22.52	22.54
5	1	12		22.49	22.51	22.49
5	1	24		22.61	22.56	22.55
5	12	0		21.50	21.52	21.59
5	12	7		21.58	21.60	21.58



5	12	13	64-QAM	21.65	21.62	21.64
5	25	0		21.56	21.56	21.64
5	1	0		21.72	21.60	21.62
5	1	12		21.64	21.53	21.65
5	1	24		21.78	21.74	21.36
5	12	0		20.60	20.54	20.55
5	12	7		20.68	20.63	20.58
5	12	13		20.68	20.65	20.52
5	25	0		20.58	20.55	20.53



LTE Band 25 Maximum Average Power [dBm]						
BW [MHz]	RB Size	RB Offset	Mod	Lowest	Middle	Highest
3	1	0	QPSK	22.23	22.16	22.18
3	1	8		22.29	22.33	22.35
3	1	14		22.28	22.32	22.29
3	8	0		22.31	22.27	22.24
3	8	4		22.36	22.38	22.35
3	8	7		22.37	22.35	22.39
3	15	0		22.36	22.31	22.28
3	1	0	16-QAM	22.49	22.51	22.67
3	1	8		22.67	22.66	22.67
3	1	14		22.62	22.68	22.65
3	8	0		21.61	21.55	21.54
3	8	4		21.55	21.60	21.66
3	8	7		21.59	21.61	21.68
3	15	0		21.62	21.59	21.64
3	1	0	64-QAM	21.65	21.65	21.62
3	1	8		21.78	21.86	21.45
3	1	14		21.74	21.75	21.45
3	8	0		20.58	20.55	20.56
3	8	4		20.62	20.58	20.45
3	8	7		20.62	20.68	20.25
3	15	0		20.57	20.57	20.40
1.4	1	0	QPSK	22.14	22.09	22.03
1.4	1	3		22.18	22.17	22.19
1.4	1	5		22.20	22.11	22.16
1.4	3	0		22.16	22.15	22.13
1.4	3	1		22.21	22.21	22.19
1.4	3	3		22.23	22.26	22.18
1.4	6	0		22.24	22.28	22.23
1.4	1	0	16-QAM	22.42	22.44	22.46
1.4	1	3		22.61	22.46	22.55
1.4	1	5		22.54	22.58	22.52
1.4	3	0		22.30	22.22	22.27
1.4	3	1		22.27	22.33	22.27



1.4	3	3	64-QAM	22.27	22.30	22.25
1.4	6	0		21.56	21.52	21.52
1.4	1	0		21.65	21.49	21.21
1.4	1	3		21.71	21.68	21.45
1.4	1	5		21.58	21.62	21.36
1.4	3	0		21.58	21.50	21.19
1.4	3	1		21.62	21.61	21.17
1.4	3	3		21.61	21.63	21.18
1.4	6	0		20.42	20.43	20.12



LTE Band 41 Maximum Average Power [dBm]						
BW [MHz]	RB Size	RB Offset	Mod	Lowest	Middle	Highest
20	1	0	QPSK	26.09	26.3	26.03
20	1	49		26.1	26.08	26.24
20	1	99		26.07	26.23	26.02
20	50	0		25.7	25.89	25.86
20	50	24		25.72	25.48	25.67
20	50	50		25.69	25.42	25.4
20	100	0		25.72	25.73	25.67
20	1	0	16-QAM	25.76	25.68	25.32
20	1	49		25.81	25.72	25.34
20	1	99		25.74	25.47	25.34
20	50	0		24.89	24.5	24.58
20	50	24		24.89	24.46	24.68
20	50	50		24.92	24.68	24.58
20	100	0		24.81	24.39	24.69
20	1	0	64-QAM	24.43	24.8	24.56
20	1	49		24.83	24.79	24.68
20	1	99		24.84	24.54	24.45
20	50	0		23.4	23.45	23.56
20	50	24		23.47	23.56	23.45
20	50	50		23.43	23.45	23.56
20	100	0		23.43	23.44	23.21
15	1	0	QPSK	26.15	26.17	26.28
15	1	37		26.16	26.12	26.12
15	1	74		26.13	26.12	26.09
15	36	0		26.11	25.98	25.86
15	36	20		26.12	25.98	25.98
15	36	39		26	26.04	25.94
15	75	0		26.12	26.01	25.87
15	1	0	16-QAM	26.12	25.88	25.86
15	1	37		26.01	25.74	26.1
15	1	74		26.04	25.87	25.91
15	36	0		25.44	25.33	25.46
15	36	20		25.33	25.66	25.36



15	36	39	64-QAM	25.45	25.34	25.16
15	75	0		25.68	25.44	25.3
15	1	0		25.34	25.05	25.44
15	1	37		25.55	25.34	25.45
15	1	74		25.54	25.44	25.52
15	36	0		24.45	24.42	24.62
15	36	20		24.56	24.4	24.51
15	36	39		24.66	24.37	24.27
15	75	0		24.81	24.45	24.37



LTE Band 41 Maximum Average Power [dBm]						
BW [MHz]	RB Size	RB Offset	Mod	Lowest	Middle	Highest
10	1	0	QPSK	26.07	25.95	26
10	1	25		26.04	26.02	25.98
10	1	49		26.06	26.09	26.06
10	25	0		26.18	26.12	26.12
10	25	12		26.21	26.11	26.11
10	25	25		26.18	26.21	26.01
10	50	0		26.23	26.12	26.03
10	1	0	16-QAM	26.12	26.21	26.12
10	1	25		26.12	26.12	26.24
10	1	49		26.12	26.21	25.98
10	25	0		25.7	25.31	25.65
10	25	12		25.73	25.33	25.45
10	25	25		25.73	25.33	25.55
10	50	0		25.63	25.34	25.45
10	1	0	64-QAM	25.61	25.56	25.43
10	1	25		25.58	25.35	25.37
10	1	49		25.51	25.43	25.55
10	25	0		24.71	24.56	24.45
10	25	12		24.78	24.55	24.56
10	25	25		24.77	24.65	24.67
10	50	0		24.65	24.67	24.45
5	1	0	QPSK	26.02	25.96	25.94
5	1	12		26.02	26.03	25.84
5	1	24		26.01	26	26.02
5	12	0		26.2	26.12	26.13
5	12	7		26.23	26.21	26.06
5	12	13		26.22	26.22	26.09
5	25	0		26.18	26.13	25.91
5	1	0	16-QAM	26.12	26.11	26.28
5	1	12		26.11	26.12	26.22
5	1	24		26.15	26.22	26.11
5	12	0		25.66	25.45	25.23
5	12	7		25.73	25.33	25.34



5	12	13	64-QAM	25.72	25.23	25.43
5	25	0		25.45	25.32	25.12
5	1	0		25.47	25.21	25.47
5	1	12		25.41	25.34	25.34
5	1	24		25.45	25.31	25.23
5	12	0		24.21	24.67	24.33
5	12	7		24.45	24.66	24.31
5	12	13		24.34	24.45	24.2
5	25	0		24.55	24.56	24.15



LTE Band 71 Maximum Average Power [dBm]						
BW [MHz]	RB Size	RB Offset	Mod	Lowest	Middle	Highest
20	1	0	QPSK	23.20	23.22	23.12
20	1	49		23.12	23.00	23.01
20	1	99		23.02	23.01	23.02
20	50	0		22.84	23.00	22.98
20	50	24		22.73	22.70	22.76
20	50	50		22.73	22.71	22.63
20	100	0		22.74	22.75	22.70
20	1	0	16-QAM	23.21	23.05	23.08
20	1	49		22.92	23.05	22.86
20	1	99		22.80	22.94	22.77
20	50	0		22.50	22.43	22.38
20	50	24		22.54	22.42	22.38
20	50	50		22.40	22.45	22.37
20	100	0		22.41	22.41	22.42
20	1	0	64-QAM	22.30	22.57	22.58
20	1	49		22.43	22.57	22.42
20	1	99		22.37	22.36	22.26
20	50	0		21.03	21.44	21.53
20	50	24		21.47	21.42	21.43
20	50	50		21.42	21.48	21.43
20	100	0		21.36	21.48	21.33
15	1	0	QPSK	23.04	22.98	22.86
15	1	37		22.87	22.89	22.89
15	1	74		22.75	22.69	22.66
15	36	0		23.03	23.01	22.91
15	36	20		22.98	22.99	22.86
15	36	39		22.93	22.86	22.80
15	75	0		23.02	22.87	22.79
15	1	0	16-QAM	23.11	23.19	22.99
15	1	37		22.98	22.87	22.93
15	1	74		22.82	22.77	22.86
15	36	0		22.53	22.48	22.46
15	36	20		22.50	22.46	22.38
15	36	39		22.47	22.34	22.37



15	75	0		22.46	22.36	22.41
15	1	0	64-QAM	22.31	22.68	22.57
15	1	37		22.56	22.54	22.60
15	1	74		22.47	22.49	22.38
15	36	0		21.47	21.48	21.49
15	36	20		21.03	21.45	21.44
15	36	39		21.43	21.48	21.49
15	75	0		21.35	21.44	21.47



LTE Band 71 Maximum Average Power [dBm]						
BW [MHz]	RB Size	RB Offset	Mod	Lowest	Middle	Highest
10	1	0	QPSK	22.83	22.77	22.62
10	1	25		22.60	22.60	22.61
10	1	49		22.59	22.46	22.34
10	25	0		22.89	22.76	22.68
10	25	12		22.78	22.82	22.72
10	25	25		22.71	22.73	22.59
10	50	0		22.78	22.77	22.78
10	1	0	16-QAM	23.09	22.84	22.77
10	1	25		22.99	22.75	22.80
10	1	49		22.73	22.77	22.67
10	25	0		22.33	22.26	22.18
10	25	12		22.30	22.27	22.26
10	25	25		22.25	22.32	22.13
10	50	0		22.32	22.25	22.23
10	1	0	64-QAM	22.14	22.34	22.14
10	1	25		22.31	22.33	22.38
10	1	49		22.16	22.25	22.08
10	25	0		20.91	21.33	21.24
10	25	12		20.89	21.36	21.27
10	25	25		20.91	21.26	21.19
10	50	0		21.30	21.31	21.31
5	1	0	QPSK	22.79	22.71	22.57
5	1	12		22.85	22.65	22.54
5	1	24		22.69	22.59	22.54
5	12	0		22.94	22.76	22.66
5	12	7		22.93	22.83	22.64
5	12	13		22.80	22.67	22.64
5	25	0		22.87	22.71	22.65
5	1	0	16-QAM	23.02	22.89	22.76
5	1	12		22.86	22.83	22.63
5	1	24		22.87	22.79	22.61
5	12	0		22.46	22.34	22.22
5	12	7		22.38	22.35	22.16



5	12	13	64-QAM	22.30	22.25	22.17
5	25	0		22.36	22.30	22.13
5	1	0		22.37	22.50	22.45
5	1	12		22.05	22.50	22.12
5	1	24		22.27	22.30	22.16
5	12	0		20.86	21.33	21.19
5	12	7		20.90	21.35	21.17
5	12	13		20.93	21.33	21.19
5	25	0		21.11	21.26	21.13



CA Power

CA_41C								
Combination 20MHz+20MHz (100RB+100RB)								
PCC Channel	SCC Channel	Modulation	PCC		SCC		Total RB Size	Measured Power (dBm)
			RB Size	RB offset	RB Size	RB offset		
39750	39948	QPSK	0	0	1	99	1	23.72
			1	0	0	0	1	23.72
			100	0	0	0	100	23.88
			100	0	100	0	200	23.4
			1	0	1	99	2	17.68
			1	0	1	0	2	20.25
			1	99	1	0	2	23.82
			100	0	1	99	101	22.76
		16QAM	0	0	1	99	1	23.73
			1	0	0	0	1	23.6
			100	0	0	0	100	23.7
			100	0	100	0	200	22.44
			1	0	1	99	2	17.57
			1	0	1	0	2	20.28
			1	99	1	0	2	23.89
			100	0	1	99	101	22.79
		64QAM	0	0	1	99	1	22.88
			1	0	0	0	1	22.85
			100	0	0	0	100	22.78
			100	0	100	0	200	21.57
			1	0	1	99	2	17.58
			1	0	1	0	2	19.91
			1	99	1	0	2	23.02
			100	0	1	99	101	22.66



40521	40719	QPSK	0	0	1	99	1	23.42
			1	0	0	0	1	23.47
			100	0	0	0	100	23.87
			100	0	100	0	200	23.87
			1	0	1	99	2	17.54
			1	0	1	0	2	19.95
			1	99	1	0	2	23.85
			100	0	1	99	101	22.28
		16QAM	0	0	1	99	1	23.72
			1	0	0	0	1	23.73
			100	0	0	0	100	23.84
			100	0	100	0	200	23.37
			1	0	1	99	2	17.74
			1	0	1	0	2	20.16
			1	99	1	0	2	23.88
			100	0	1	99	101	23.26
		64QAM	0	0	1	99	1	22.91
			1	0	0	0	1	23.7
			100	0	0	0	100	23.02
			100	0	100	0	200	22.62
			1	0	1	99	2	17.31
			1	0	1	0	2	19.82
			1	99	1	0	2	23.71
			100	0	1	99	101	22.49



41292	41490	QPSK	0	0	1	99	1	23.12
			1	0	0	0	1	23.18
			100	0	0	0	100	22.86
			100	0	100	0	200	23.17
			1	0	1	99	2	17.37
			1	0	1	0	2	19.77
			1	99	1	0	2	23.88
			100	0	1	99	101	22.54
		16QAM	0	0	1	99	1	23.07
			1	0	0	0	1	23.42
			100	0	0	0	100	23.45
			100	0	100	0	200	23.09
			1	0	1	99	2	17.43
			1	0	1	0	2	17.42
			1	99	1	0	2	19.98
			100	0	1	99	101	22.49
		64QAM	0	0	1	99	1	22.89
			1	0	0	0	1	22.74
			100	0	0	0	100	22.69
			100	0	100	0	200	22.12
			1	0	1	99	2	17
			1	0	1	0	2	19.64
			1	99	1	0	2	23.69
			100	0	1	99	101	22.41



CA_41C								
Combination 20MHz+15MHz (100RB+75RB)								
PCC Channel	SCC Channel	Modulation	PCC		SCC		Total RB Size	Measured Power (dBm)
			RB Size	RB offset	RB Size	RB offset		
39750	39921	QPSK	100	0	75	0	175	23.93
		QPSK	1	0	1	74	2	17.24
		QPSK	1	99	1	0	2	23.87
		16QAM	100	0	75	0	175	23.31
		16QAM	1	0	1	74	2	17.58
		16QAM	1	99	1	0	2	23.78
		64QAM	100	0	75	0	175	22.48
		64QAM	1	0	1	74	2	17.36
		64QAM	1	99	1	0	2	23.47
40546	40717	QPSK	100	0	75	0	175	23.15
		QPSK	1	0	1	74	2	17.71
		QPSK	1	99	1	0	2	23.27
		16QAM	100	0	75	0	175	22.28
		16QAM	1	0	1	74	2	17.7
		16QAM	1	99	1	0	2	23.07
		64QAM	100	0	75	0	175	21.4
		64QAM	1	0	1	74	2	17.15
		64QAM	1	99	1	0	2	22.96
41341	41512	QPSK	100	0	75	0	175	23.1
		QPSK	1	0	1	74	2	16.89
		QPSK	1	99	1	0	2	23
		16QAM	100	0	75	0	175	22.45
		16QAM	1	0	1	74	2	17.98
		16QAM	1	99	1	0	2	23.01
		64QAM	100	0	75	0	175	21.12
		64QAM	1	0	1	74	2	17.11
		64QAM	1	99	1	0	2	22.91



Combination 15MHz+20MHz (75RB+100RB)								
PCC Channel	SCC Channel	Modulation	PCC		SCC		Total RB Size	Measured Power (dBm)
			RB Size	RB offset	RB Size	RB offset		
39728	39899	QPSK	75	0	100	0	175	23.84
		QPSK	1	0	1	99	2	17.33
		QPSK	1	74	1	0	2	23.88
		16QAM	75	0	100	0	175	23.34
		16QAM	1	0	1	99	2	17.61
		16QAM	1	74	1	0	2	23.75
		64QAM	75	0	100	0	175	22.51
		64QAM	1	0	1	99	2	17.39
		64QAM	1	74	1	0	2	23.5
40523	40694	QPSK	75	0	100	0	175	23.18
		QPSK	1	0	1	99	2	17.74
		QPSK	1	74	1	0	2	23.3
		16QAM	75	0	100	0	175	22.31
		16QAM	1	0	1	99	2	17.73
		16QAM	1	74	1	0	2	23.1
		64QAM	75	0	100	0	175	21.43
		64QAM	1	0	1	99	2	17.19
		64QAM	1	74	1	0	2	23
41319	41490	QPSK	75	0	100	0	175	23.14
		QPSK	1	0	1	99	2	16.93
		QPSK	1	74	1	0	2	23.04
		16QAM	75	0	100	0	175	22.49
		16QAM	1	0	1	99	2	18.02
		16QAM	1	74	1	0	2	23.05
		64QAM	75	0	100	0	175	21.16
		64QAM	1	0	1	99	2	17.15
		64QAM	1	74	1	0	2	22.95



Combination 20MHz+10MHz (100RB+50RB)								
PCC	SCC	Modulation	PCC		SCC		Total RB Size	Measured Power (dBm)
Channel	Channel		RB Size	RB offset	RB Size	RB offset		
39750	39894	QPSK	100	0	50	0	150	23.75
		QPSK	1	0	1	49	2	17.42
		QPSK	1	99	1	0	2	23.77
		16QAM	100	0	50	0	150	23.37
		16QAM	1	0	1	49	2	17.64
		16QAM	1	99	1	0	2	23.74
		64QAM	100	0	50	0	150	22.54
		64QAM	1	0	1	49	2	17.42
		64QAM	1	99	1	0	2	23.53
40571	40715	QPSK	100	0	50	0	150	23.21
		QPSK	1	0	1	49	2	17.77
		QPSK	1	99	1	0	2	23.33
		16QAM	100	0	50	0	150	22.34
		16QAM	1	0	1	49	2	17.76
		16QAM	1	99	1	0	2	23.13
		64QAM	100	0	50	0	150	21.46
		64QAM	1	0	1	49	2	17.23
		64QAM	1	99	1	0	2	23.04
41391	41535	QPSK	100	0	50	0	150	23.18
		QPSK	1	0	1	49	2	16.97
		QPSK	1	99	1	0	2	23.08
		16QAM	100	0	50	0	150	22.53
		16QAM	1	0	1	49	2	18.06
		16QAM	1	99	1	0	2	23.09
		64QAM	100	0	50	0	150	21.2
		64QAM	1	0	1	49	2	17.19
		64QAM	1	99	1	0	2	22.99



Combination 10MHz+20MHz (50RB+100RB)								
PCC	SCC	Modulation	PCC		SCC		Total RB Size	Measured Power (dBm)
Channel	Channel		RB Size	RB offset	RB Size	RB offset		
39705	39849	QPSK	50	0	100	0	150	23.85
		QPSK	1	0	1	99	2	17.51
		QPSK	1	49	1	0	2	23.84
		16QAM	50	0	100	0	150	23.4
		16QAM	1	0	1	99	2	17.67
		16QAM	1	49	1	0	2	23.63
		64QAM	50	0	100	0	150	22.57
		64QAM	1	0	1	99	2	17.45
		64QAM	1	49	1	0	2	23.56
40526	40670	QPSK	50	0	100	0	150	23.24
		QPSK	1	0	1	99	2	17.8
		QPSK	1	49	1	0	2	23.36
		16QAM	50	0	100	0	150	22.37
		16QAM	1	0	1	99	2	17.79
		16QAM	1	49	1	0	2	23.16
		64QAM	50	0	100	0	150	21.49
		64QAM	1	0	1	99	2	17.27
		64QAM	1	49	1	0	2	23.08
41346	41490	QPSK	50	0	100	0	150	23.22
		QPSK	1	0	1	99	2	17.01
		QPSK	1	49	1	0	2	23.12
		16QAM	50	0	100	0	150	22.57
		16QAM	1	0	1	99	2	18.1
		16QAM	1	49	1	0	2	23.13
		64QAM	50	0	100	0	150	21.24
		64QAM	1	0	1	99	2	17.23
		64QAM	1	49	1	0	2	23.03



Combination 20MHz+5MHz (100RB+25RB)								
PCC	SCC	Modulation	PCC		SCC		Total RB Size	Measured Power (dBm)
Channel	Channel		RB Size	RB offset	RB Size	RB offset		
39750	39867	QPSK	100	0	25	0	125	23.42
		QPSK	1	0	1	24	2	17.6
		QPSK	1	99	1	0	2	23.44
		16QAM	100	0	25	0	125	22.42
		16QAM	1	0	1	24	2	17.7
		16QAM	1	99	1	0	2	23.53
		64QAM	100	0	25	0	125	22.6
		64QAM	1	0	1	24	2	17.48
		64QAM	1	99	1	0	2	23.59
40595	40712	QPSK	100	0	25	0	125	23.27
		QPSK	1	0	1	24	2	17.83
		QPSK	1	99	1	0	2	23.39
		16QAM	100	0	25	0	125	22.4
		16QAM	1	0	1	24	2	17.82
		16QAM	1	99	1	0	2	23.19
		64QAM	100	0	25	0	125	21.52
		64QAM	1	0	1	24	2	17.31
		64QAM	1	99	1	0	2	23.01
41440	41557	QPSK	100	0	25	0	125	23.15
		QPSK	1	0	1	24	2	16.94
		QPSK	1	99	1	0	2	23.05
		16QAM	100	0	25	0	125	22.5
		16QAM	1	0	1	24	2	18.03
		16QAM	1	99	1	0	2	23.06
		64QAM	100	0	25	0	125	21.17
		64QAM	1	0	1	24	2	17.16
		64QAM	1	99	1	0	2	22.96



Combination 5MHz+20MHz (25RB+100RB)								
PCC	SCC	Modulation	PCC		SCC		Total RB Size	Measured Power (dBm)
Channel	Channel		RB Size	RB offset	RB Size	RB offset		
39683	39800	QPSK	25	0	100	0	125	23.22
		QPSK	1	0	1	99	2	17.69
		QPSK	1	24	1	0	2	23.56
		16QAM	25	0	100	0	125	22.12
		16QAM	1	0	1	99	2	17.73
		16QAM	1	24	1	0	2	23.63
		64QAM	25	0	100	0	125	22.63
		64QAM	1	0	1	99	2	17.51
		64QAM	1	24	1	0	2	23.62
40528	40645	QPSK	25	0	100	0	125	23.3
		QPSK	1	0	1	99	2	17.86
		QPSK	1	24	1	0	2	23.42
		16QAM	25	0	100	0	125	22.43
		16QAM	1	0	1	99	2	17.85
		16QAM	1	24	1	0	2	23.22
		64QAM	25	0	100	0	125	21.55
		64QAM	1	0	1	99	2	17.35
		64QAM	1	24	1	0	2	22.94
41373	41490	QPSK	25	0	100	0	125	23.08
		QPSK	1	0	1	99	2	16.87
		QPSK	1	24	1	0	2	22.98
		16QAM	25	0	100	0	125	22.43
		16QAM	1	0	1	99	2	17.96
		16QAM	1	24	1	0	2	22.99
		64QAM	25	0	100	0	125	21.1
		64QAM	1	0	1	99	2	17.09
		64QAM	1	24	1	0	2	22.89



Combination 15MHz+15MHz (75RB+75RB)								
PCC	SCC	Modulation	PCC		SCC		Total RB Size	Measured Power (dBm)
Channel	Channel		RB Size	RB offset	RB Size	RB offset		
39725	39875	QPSK	75	0	75	0	150	23.02
		QPSK	1	0	1	74	2	17.96
		QPSK	1	74	1	0	2	23.56
		16QAM	75	0	75	0	150	23.55
		16QAM	1	0	1	74	2	17.82
		16QAM	1	74	1	0	2	23.4
		64QAM	75	0	75	0	150	22.72
		64QAM	1	0	1	74	2	17.6
		64QAM	1	74	1	0	2	23.71
40545	40695	QPSK	75	0	75	0	150	23.39
		QPSK	1	0	1	74	2	17.95
		QPSK	1	74	1	0	2	23.51
		16QAM	75	0	75	0	150	22.52
		16QAM	1	0	1	74	2	17.94
		16QAM	1	74	1	0	2	23.31
		64QAM	75	0	75	0	150	21.64
		64QAM	1	0	1	74	2	17.47
		64QAM	1	74	1	0	2	22.73
41365	41515	QPSK	75	0	75	0	150	22.87
		QPSK	1	0	1	74	2	16.66
		QPSK	1	74	1	0	2	22.77
		16QAM	75	0	75	0	150	22.22
		16QAM	1	0	1	74	2	17.75
		16QAM	1	74	1	0	2	22.78
		64QAM	75	0	75	0	150	20.89
		64QAM	1	0	1	74	2	16.88
		64QAM	1	74	1	0	2	22.68



Combination 15MHz+10MHz (75RB+50RB)								
PCC	SCC	Modulation	PCC		SCC		Total RB Size	Measured Power (dBm)
Channel	Channel		RB Size	RB offset	RB Size	RB offset		
39725	39845	QPSK	75	0	50	0	125	23.56
		QPSK	1	0	1	49	2	17.78
		QPSK	1	74	1	0	2	23.45
		16QAM	75	0	50	0	125	22.34
		16QAM	1	0	1	49	2	17.76
		16QAM	1	74	1	0	2	23.72
		64QAM	75	0	50	0	125	22.66
		64QAM	1	0	1	49	2	17.54
		64QAM	1	74	1	0	2	23.65
40571	40691	QPSK	75	0	50	0	125	23.33
		QPSK	1	0	1	49	2	17.89
		QPSK	1	74	1	0	2	23.45
		16QAM	75	0	50	0	125	22.46
		16QAM	1	0	1	49	2	17.88
		16QAM	1	74	1	0	2	23.25
		64QAM	75	0	50	0	125	21.58
		64QAM	1	0	1	49	2	17.39
		64QAM	1	74	1	0	2	22.87
41417	41537	QPSK	75	0	50	0	125	23.01
		QPSK	1	0	1	49	2	16.8
		QPSK	1	74	1	0	2	22.91
		16QAM	75	0	50	0	125	22.36
		16QAM	1	0	1	49	2	17.89
		16QAM	1	74	1	0	2	22.92
		64QAM	75	0	50	0	125	21.03
		64QAM	1	0	1	49	2	17.02
		64QAM	1	74	1	0	2	22.82



Combination 10MHz+15MHz (50RB+75RB)								
PCC	SCC	Modulation	PCC		SCC		Total RB Size	Measured Power (dBm)
Channel	Channel		RB Size	RB offset	RB Size	RB offset		
39703	39823	QPSK	50	0	75	0	125	23.85
		QPSK	1	49	1	0	2	17.87
		QPSK	1	0	1	74	2	23.96
		16QAM	50	0	75	0	125	22.52
		16QAM	1	49	1	0	2	17.79
		16QAM	1	0	1	74	2	23.92
		64QAM	50	0	75	0	125	22.69
		64QAM	1	49	1	0	2	17.57
		64QAM	1	0	1	74	2	23.68
40549	40669	QPSK	50	0	75	0	125	23.36
		QPSK	1	49	1	0	2	17.92
		QPSK	1	0	1	74	2	23.48
		16QAM	50	0	75	0	125	22.49
		16QAM	1	49	1	0	2	17.91
		16QAM	1	0	1	74	2	23.28
		64QAM	50	0	75	0	125	21.61
		64QAM	1	49	1	0	2	17.43
		64QAM	1	0	1	74	2	22.8
41395	41515	QPSK	50	0	75	0	125	22.94
		QPSK	1	49	1	0	2	16.73
		QPSK	1	0	1	74	2	22.84
		16QAM	50	0	75	0	125	22.29
		16QAM	1	49	1	0	2	17.82
		16QAM	1	0	1	74	2	22.85
		64QAM	50	0	75	0	125	20.96
		64QAM	1	49	1	0	2	16.95
		64QAM	1	0	1	74	2	22.75



LTE Band 7

ERP/EIRP

LTE Band 13 (GT - LC = -2.34 dB) QPSK						
Bandwidth	5M			10M		
Channel	23205	23230	23255	23230		
	(Low)	(Mid)	(High)	-	(Mid)	-
Frequency	779.5	782	784.5	-	782	-
(MHz)						
Conducted Power (dBm)	22.45	22.22	22.39		22.57	-
Conducted Power (Watts)	0.1758	0.1667	0.1734		0.1807	-
ERP(dBm)	17.96	17.73	17.90		18.08	-
ERP(Watts)	0.0625	0.0593	0.0617		0.0643	-

LTE Band 13 (GT - LC = -2.34 dB) 16QAM						
Bandwidth	5M			10M		
Channel	23205	23230	23255	23230		
	(Low)	(Mid)	(High)	-	(Mid)	-
Frequency	779.5	782	784.5	-	782	-
(MHz)						
Conducted Power (dBm)	22.45	22.45	22.53		22.41	-
Conducted Power (Watts)	0.1758	0.1758	0.1791		0.1742	-
ERP(dBm)	17.96	17.96	18.04		17.92	-
ERP(Watts)	0.0625	0.0625	0.0637		0.0619	-



LTE Band 13 (GT - LC = -2.34 dB) 64QAM						
Bandwidth	5M			10M		
Channel	23205	23230	23255	23230		
	(Low)	(Mid)	(High)	-	(Mid)	-
Frequency	779.5	782	784.5	-	782	-
(MHz)						
Conducted Power (dBm)	21.23	21.34	21.32		21.56	-
Conducted Power (Watts)	0.1327	0.1361	0.1355		0.1432	-
ERP(dBm)	16.74	16.85	16.83		17.07	-
ERP(Watts)	0.0472	0.0484	0.0482		0.0509	-



LTE Band 25 (GT - LC =1.32 dB) QPSK									
Bandwidth	1.4M			3M			5M		
Channel	26407	26340	26683	26055	26340	26675	26065	26340	26665
	(Low)	(Mid)	(High)	(Low)	(Mid)	(High)	(Low)	(Mid)	(High)
Frequency (MHz)	1850.7	1880	1914.3	1851.5	1880	1913.5	1852.5	1880	1912.5
Conducted Power (dBm)	22.24	22.28	22.23	22.37	22.35	22.39	22.32	22.31	22.46
Conducted Power (Watts)	0.1675	0.1690	0.1671	0.1726	0.1718	0.1734	0.1706	0.1702	0.1762
EIRP(dBm)	23.56	23.60	23.55	23.69	23.67	23.71	23.64	23.63	23.78
EIRP(Watts)	0.2270	0.2291	0.2265	0.2339	0.2328	0.2350	0.2312	0.2307	0.2388

LTE Band 25 (GT - LC = 1.32 dB) QPSK									
Bandwidth	10M			15M			20M		
Channel	26090	26340	26640	26115	26340	26615	26140	26340	26590
	(Low)	(Mid)	(High)	(Low)	(Mid)	(High)	(Low)	(Mid)	(High)
Frequency (MHz)	1855	1880	1910	1857.5	1880	1907.5	1860	1880	1905
Conducted Power (dBm)	22.44	22.17	22.22	22.55	22.59	22.65	22.84	22.92	22.87
Conducted Power (Watts)	0.1754	0.1648	0.1667	0.1799	0.1816	0.1841	0.1923	0.1959	0.1936
EIRP(dBm)	23.76	23.49	23.54	23.87	23.91	23.97	24.16	24.24	24.19
EIRP(Watts)	0.2377	0.2234	0.2259	0.2438	0.2460	0.2495	0.2606	0.2655	0.2624



LTE Band 25 (GT - LC = 1.32 dB) 16QAM									
Bandwidth	1.4M			3M			5M		
Channel	26407	26340	26683	26055	26340	26675	26065	26340	26665
	(Low)	(Mid)	(High)	(Low)	(Mid)	(High)	(Low)	(Mid)	(High)
Frequency (MHz)	1850.7	1880	1914.3	1851.5	1880	1913.5	1852.5	1880	1912.5
Conducted Power (dBm)	22.61	22.46	22.55	22.62	22.68	22.65	22.61	22.56	22.55
Conducted Power (Watts)	0.1824	0.1762	0.1799	0.1828	0.1854	0.1841	0.1824	0.1803	0.1799
EIRP(dBm)	23.93	23.78	23.87	23.94	24.00	23.97	23.93	23.88	23.87
EIRP(Watts)	0.2472	0.2388	0.2438	0.2477	0.2512	0.2495	0.2472	0.2443	0.2438

LTE Band 25 (GT - LC = 1.32 dB) 16QAM									
Bandwidth	10M			15M			20M		
Channel	26090	26340	26640	26115	26340	26615	26140	26340	26590
	(Low)	(Mid)	(High)	(Low)	(Mid)	(High)	(Low)	(Mid)	(High)
Frequency (MHz)	1855	1880	1910	1857.5	1880	1907.5	1860	1880	1905
Conducted Power (dBm)	22.66	22.63	22.68	22.65	22.59	22.57	22.60	22.57	22.65
Conducted Power (Watts)	0.1845	0.1832	0.1854	0.1841	0.1816	0.1807	0.1820	0.1807	0.1841
EIRP(dBm)	23.98	23.95	24.00	23.97	23.91	23.89	23.92	23.89	23.97
EIRP(Watts)	0.2500	0.2483	0.2512	0.2495	0.2460	0.2449	0.2466	0.2449	0.2495



LTE Band 25 (GT - LC = 1.32 dB) 64QAM									
Bandwidth	1.4M			3M			5M		
Channel	26407	26340	26683	26055	26340	26675	26065	26340	26665
	(Low)	(Mid)	(High)	(Low)	(Mid)	(High)	(Low)	(Mid)	(High)
Frequency (MHz)	1850.7	1880	1914.3	1851.5	1880	1913.5	1852.5	1880	1912.5
Conducted Power (dBm)	21.71	21.68	21.45	21.78	21.86	21.45	21.78	21.74	21.36
Conducted Power (Watts)	0.1483	0.1472	0.1396	0.1507	0.1535	0.1396	0.1507	0.1493	0.1368
EIRP(dBm)	23.03	23.00	22.77	23.10	23.18	22.77	23.10	23.06	22.68
EIRP(Watts)	0.2009	0.1995	0.1892	0.2042	0.2080	0.1892	0.2042	0.2023	0.1854

LTE Band 25 (GT - LC = 1.32 dB) 64QAM									
Bandwidth	10M			15M			20M		
Channel	26090	26340	26640	26115	26340	26615	26140	26340	26590
	(Low)	(Mid)	(High)	(Low)	(Mid)	(High)	(Low)	(Mid)	(High)
Frequency (MHz)	1855	1880	1910	1857.5	1880	1907.5	1860	1880	1905
Conducted Power (dBm)	21.75	21.77	21.44	21.89	21.93	21.73	21.90	21.75	21.65
Conducted Power (Watts)	0.1496	0.1503	0.1393	0.1545	0.1560	0.1489	0.1549	0.1496	0.1462
EIRP(dBm)	23.07	23.09	22.76	23.21	23.25	23.05	23.22	23.07	22.97
EIRP(Watts)	0.2028	0.2037	0.1888	0.2094	0.2113	0.2018	0.2099	0.2028	0.1982



LTE Band 41 (G _T - L _C = 3.02 dB) QPSK									
Bandwidth	5M			10M			15M		
Channel	39675	40620	41565	39700	40620	41540	39725	40620	41515
	(Low)	(Mid)	(High)	(Low)	(Mid)	(High)	(Low)	(Mid)	(High)
Frequency (MHz)	2498.5	2593	2687.5	2501	2593	2685	2503.5	2593	2682.5
Conducted Power (dBm)	26.23	26.21	26.06	26.23	26.12	26.03	26.15	26.17	26.28
Conducted Power (Watts)	0.4198	0.4178	0.4036	0.4198	0.4093	0.4009	0.4121	0.4140	0.4246
EIRP(dBm)	29.25	29.23	29.08	29.25	29.14	29.05	29.17	29.19	29.30
EIRP(Watts)	0.8414	0.8375	0.8091	0.8414	0.8204	0.8035	0.8260	0.8299	0.8511

LTE Band 41 (G _T - L _C = 3.02 dB) QPSK			
Bandwidth	20M		
Channel	39750	40620	41490
	(Low)	(Mid)	(High)
Frequency (MHz)	2506	2593	2680
Conducted Power (dBm)	26.09	26.30	26.03
Conducted Power (Watts)	0.4064	0.4266	0.4009
EIRP(dBm)	29.11	29.32	29.05
EIRP(Watts)	0.8147	0.8551	0.8035



LTE Band 41 (G _T - L _C = 3.02 dB) 16QAM									
Bandwidth	5M			10M			15M		
Channel	39675	40620	41565	39700	40620	41540	39725	40620	41515
	(Low)	(Mid)	(High)	(Low)	(Mid)	(High)	(Low)	(Mid)	(High)
Frequency	2498.5	2593	2687.5	2501	2593	2685	2503.5	2593	2682.5
(MHz)									
Conducted Power (dBm)	26.12	26.11	26.28	26.12	26.12	26.24	26.12	25.88	25.86
Conducted Power (Watts)	0.4093	0.4083	0.4246	0.4093	0.4093	0.4207	0.4093	0.3873	0.3855
EIRP(dBm)	29.14	29.13	29.30	29.14	29.14	29.26	29.14	28.90	28.88
EIRP(Watts)	0.8204	0.8185	0.8511	0.8204	0.8204	0.8433	0.8204	0.7762	0.7727

LTE Band 41 (G _T - L _C = 3.02 dB) 16QAM			
Bandwidth	20M		
Channel	39750	40620	41490
	(Low)	(Mid)	(High)
Frequency	2506	2593	2680
(MHz)			
Conducted Power (dBm)	25.81	25.72	25.34
Conducted Power (Watts)	0.3811	0.3733	0.3420
EIRP(dBm)	28.83	28.74	28.36
EIRP(Watts)	0.7638	0.7482	0.6855



LTE Band 41 (G _T - L _C = 3.02 dB) 64QAM									
Bandwidth	5M			10M			15M		
Channel	39675	40620	41565	39700	40620	41540	39725	40620	41515
	(Low)	(Mid)	(High)	(Low)	(Mid)	(High)	(Low)	(Mid)	(High)
Frequency (MHz)	2498.5	2593	2687.5	2501	2593	2685	2503.5	2593	2682.5
Conducted Power (dBm)	25.47	25.21	25.47	25.61	25.56	25.43	25.55	25.34	25.45
Conducted Power (Watts)	0.3524	0.3319	0.3524	0.3639	0.3597	0.3491	0.3589	0.3420	0.3508
EIRP(dBm)	28.49	28.23	28.49	28.63	28.58	28.45	28.57	28.36	28.47
EIRP(Watts)	0.7063	0.6653	0.7063	0.7295	0.7211	0.6998	0.7194	0.6855	0.7031

LTE Band 41 (G _T - L _C = 3.02 dB) 64QAM			
Bandwidth	20M		
Channel	39750	40620	41490
	(Low)	(Mid)	(High)
Frequency (MHz)	2506	2593	2680
Conducted Power (dBm)	24.84	24.54	24.45
Conducted Power (Watts)	0.3048	0.2844	0.2786
EIRP(dBm)	27.86	27.56	27.47
EIRP(Watts)	0.6109	0.5702	0.5585



LTE Band 71 (GT - LC = -1.72 dB) QPSK									
Bandwidth	5M			10M			15M		
Channel	133147	133297	133447	133172	133297	133422	133197	133297	133397
	(Low)	(Mid)	(High)	(Low)	(Mid)	(High)	(Low)	(Mid)	(High)
Frequency	665.5	680.5	695.5	668	680.5	693	670.5	680.5	690.5
(MHz)									
Conducted Power (dBm)	22.94	22.76	22.66	22.89	22.76	22.68	23.04	22.98	22.86
Conducted Power (Watts)	0.1968	0.1888	0.1845	0.1945	0.1888	0.1854	0.2014	0.1986	0.1932
ERP(dBm)	19.07	18.89	18.79	19.02	18.89	18.81	19.17	19.11	18.99
ERP(Watts)	0.0807	0.0774	0.0757	0.0798	0.0774	0.0760	0.0826	0.0815	0.0793

LTE Band 71 (GT - LC = -1.72 dB) QPSK			
Bandwidth	20M		
Channel	133222	133297	133372
	(Low)	(Mid)	(High)
Frequency	673	680.5	688
(MHz)			
Conducted Power (dBm)	23.20	23.22	23.12
Conducted Power (Watts)	0.2089	0.2099	0.2051
ERP(dBm)	19.33	19.35	19.25
ERP(Watts)	0.0857	0.0861	0.0841



LTE Band 71 (GT - LC = -1.72 dB) 16QAM									
Bandwidth	5M			10M			15M		
Channel	133147	133297	133447	133172	133297	133422	133197	133297	133397
	(Low)	(Mid)	(High)	(Low)	(Mid)	(High)	(Low)	(Mid)	(High)
Frequency (MHz)	665.5	680.5	695.5	668	680.5	693	670.5	680.5	690.5
Conducted Power (dBm)	23.02	22.89	22.76	23.09	22.84	22.77	23.11	23.19	22.99
Conducted Power (Watts)	0.2004	0.1945	0.1888	0.2037	0.1923	0.1892	0.2046	0.2084	0.1991
ERP(dBm)	19.15	19.02	18.89	19.22	18.97	18.90	19.24	19.32	19.12
ERP(Watts)	0.0822	0.0798	0.0774	0.0836	0.0789	0.0776	0.0839	0.0855	0.0817

LTE Band 71 (GT - LC = -1.72 dB)16QAM			
Bandwidth	20M		
Channel	133222	133297	133372
	(Low)	(Mid)	(High)
Frequency (MHz)	673	680.5	688
Conducted Power (dBm)	23.21	23.05	23.08
Conducted Power (Watts)	0.2094	0.2018	0.2032
ERP(dBm)	19.34	19.18	19.21
ERP(Watts)	0.0859	0.0828	0.0834



LTE Band 71 (GT - LC = -1.72 dB) 64QAM									
Bandwidth	5M			10M			15M		
Channel	133147	133297	133447	133172	133297	133422	133197	133297	133397
	(Low)	(Mid)	(High)	(Low)	(Mid)	(High)	(Low)	(Mid)	(High)
Frequency (MHz)	665.5	680.5	695.5	668	680.5	693	670.5	680.5	690.5
Conducted Power (dBm)	22.37	22.50	22.45	22.31	22.33	22.38	22.31	22.68	22.57
Conducted Power (Watts)	0.1726	0.1778	0.1758	0.1702	0.1710	0.1730	0.1702	0.1854	0.1807
ERP(dBm)	18.50	18.63	18.58	18.44	18.46	18.51	18.44	18.81	18.70
ERP(Watts)	0.0708	0.0729	0.0721	0.0698	0.0701	0.0710	0.0698	0.0760	0.0741

LTE Band 71 (GT - LC = -1.72 dB) 64QAM			
Bandwidth	20M		
Channel	133222	133297	133372
	(Low)	(Mid)	(High)
Frequency (MHz)	673	680.5	688
Conducted Power (dBm)	22.30	22.57	22.58
Conducted Power (Watts)	0.1698	0.1807	0.1811
ERP(dBm)	18.43	18.70	18.71
ERP(Watts)	0.0697	0.0741	0.0743



CA EIRP

LTE Band 41 CA (GT - LC = 3.02 dB) QPSK									
Bandwidth	15M + 15M			5M + 20M			20M + 5M		
Channel PCC	39725	40545	41365	39683	40528	41373	39750	40595	41440
	(Low)	(Mid)	(High)	(Low)	(Mid)	(High)	(Low)	(Mid)	(High)
Channel SCC	39875	40695	41515	39800	40645	41490	39867	40712	41557
	(Low)	(Mid)	(High)	(Low)	(Mid)	(High)	(Low)	(Mid)	(High)
Conducted Power (dBm)	23.71	22.73	22.68	23.56	23.42	23.08	23.44	23.39	23.15
Conducted Power (Watts)	0.2350	0.1875	0.1854	0.2270	0.2198	0.2032	0.2208	0.2183	0.2065
EIRP(dBm)	26.73	25.75	25.70	26.58	26.44	26.10	26.46	26.41	26.17
EIRP(Watts)	0.4710	0.3758	0.3715	0.4550	0.4406	0.4074	0.4426	0.4375	0.4140

LTE Band 41 CA (GT - LC = 3.02 dB) QPSK									
Bandwidth	10M + 20M			20M + 10M			15M + 20M		
Channel PCC	39705	40526	41346	39750	40571	41391	39728	40523	41319
	(Low)	(Mid)	(High)	(Low)	(Mid)	(High)	(Low)	(Mid)	(High)
Channel SCC	39849	40670	41490	39894	40715	41535	39899	40694	41490
	(Low)	(Mid)	(High)	(Low)	(Mid)	(High)	(Low)	(Mid)	(High)
Conducted Power (dBm)	23.85	23.36	23.22	23.77	23.33	23.18	23.88	23.3	23.14
Conducted Power (Watts)	0.2427	0.2168	0.2099	0.2382	0.2153	0.2080	0.2443	0.2138	0.2061
EIRP(dBm)	26.87	26.38	26.24	26.79	26.35	26.20	26.90	26.32	26.16
EIRP(Watts)	0.4864	0.4345	0.4207	0.4775	0.4315	0.4169	0.4898	0.4285	0.4130



LTE Band 41 CA (GT - LC = 3.02 dB) QPSK						
Bandwidth	20M+15M			20M+20M		
Channel PCC	39750	40546	41341	39750	40521	41292
	(Low)	(Mid)	(High)	(Low)	(Mid)	(High)
Channel SCC	39921	40717	41512	39948	40719	41490
	(Low)	(Mid)	(High)	(Low)	(Mid)	(High)
Conducted Power (dBm)	23.93	23.27	23.1	23.88	23.87	23.88
Conducted Power (Watts)	0.2472	0.2123	0.2042	0.2443	0.2438	0.2443
EIRP(dBm)	26.95	26.29	26.12	26.90	26.89	26.90
EIRP(Watts)	0.4955	0.4256	0.4093	0.4898	0.4887	0.4898

LTE Band 41 CA (GT - LC = 3.02 dB) QPSK						
Bandwidth	15M+10M			10M+15M		
Channel PCC	39725	40571	41417	39703	40549	41395
	(Low)	(Mid)	(High)	(Low)	(Mid)	(High)
Channel SCC	39845	40691	41537	39823	40669	41490
	(Low)	(Mid)	(High)	(Low)	(Mid)	(High)
Conducted Power (dBm)	23.56	23.45	23.01	23.96	23.48	22.94
Conducted Power (Watts)	0.2270	0.2213	0.2000	0.2489	0.2228	0.1968
EIRP(dBm)	26.58	26.47	26.03	26.98	26.50	25.96
EIRP(Watts)	0.4550	0.4436	0.4009	0.4989	0.4467	0.3945



LTE Band 41 CA (GT - LC = 3.02 dB) 16QAM									
Bandwidth	15M + 15M			5M + 20M			20M + 5M		
Channel PCC	39725	40545	41365	39683	40528	41373	39750	40595	41440
	(Low)	(Mid)	(High)	(Low)	(Mid)	(High)	(Low)	(Mid)	(High)
Channel SCC	39875	40695	41515	39800	40645	41490	39867	40712	41557
	(Low)	(Mid)	(High)	(Low)	(Mid)	(High)	(Low)	(Mid)	(High)
Conducted Power (dBm)	23.55	23.31	22.78	23.63	23.22	22.99	23.53	23.19	23.06
Conducted Power (Watts)	0.2265	0.2143	0.1897	0.2307	0.2099	0.1991	0.2254	0.2084	0.2023
EIRP(dBm)	26.57	26.33	25.80	26.65	26.24	26.01	26.55	26.21	26.08
EIRP(Watts)	0.4539	0.4295	0.3802	0.4624	0.4207	0.3990	0.4519	0.4178	0.4055

LTE Band 41 CA (GT - LC = 3.02 dB) 16QAM									
Bandwidth	10M + 20M			20M + 10M			15M + 20M		
Channel PCC	39705	40526	41346	39750	40571	41391	39728	40523	41319
	(Low)	(Mid)	(High)	(Low)	(Mid)	(High)	(Low)	(Mid)	(High)
Channel SCC	39849	40670	41490	39894	40715	41535	39899	40694	41490
	(Low)	(Mid)	(High)	(Low)	(Mid)	(High)	(Low)	(Mid)	(High)
Conducted Power (dBm)	23.63	23.16	23.13	23.74	23.13	23.09	23.75	23.1	23.05
Conducted Power (Watts)	0.2307	0.2070	0.2056	0.2366	0.2056	0.2037	0.2371	0.2042	0.2018
EIRP(dBm)	26.65	26.18	26.15	26.76	26.15	26.11	26.77	26.12	26.07
EIRP(Watts)	0.4624	0.4150	0.4121	0.4742	0.4121	0.4083	0.4753	0.4093	0.4046



LTE Band 41 CA (GT - LC = 3.02 dB) 16QAM						
Bandwidth	20M+15M			20M+20M		
Channel PCC	39750	40546	41341	39750	40521	41292
	(Low)	(Mid)	(High)	(Low)	(Mid)	(High)
Channel SCC	39921	40717	41512	39948	40719	41490
	(Low)	(Mid)	(High)	(Low)	(Mid)	(High)
Conducted Power (dBm)	23.78	23.07	23.01	23.89	23.88	23.45
Conducted Power (Watts)	0.2388	0.2028	0.2000	0.2449	0.2443	0.2213
EIRP(dBm)	26.80	26.09	26.03	26.91	26.90	26.47
EIRP(Watts)	0.4786	0.4064	0.4009	0.4909	0.4898	0.4436

LTE Band 41 CA (GT - LC = 3.02 dB) 16QAM						
Bandwidth	15M+10M			10M+15M		
Channel PCC	39725	40571	41417	39703	40549	41395
	(Low)	(Mid)	(High)	(Low)	(Mid)	(High)
Channel SCC	39845	40691	41537	39823	40669	41490
	(Low)	(Mid)	(High)	(Low)	(Mid)	(High)
Conducted Power (dBm)	23.72	23.25	22.92	23.92	23.28	22.85
Conducted Power (Watts)	0.2355	0.2113	0.1959	0.2466	0.2128	0.1928
EIRP(dBm)	26.74	26.27	25.94	26.94	26.30	25.87
EIRP(Watts)	0.4721	0.4236	0.3926	0.4943	0.4266	0.3864



LTE Band 41 CA (GT - LC = 3.02 dB) 64QAM									
Bandwidth	15M + 15M			5M + 20M			20M + 5M		
Channel PCC	39725	40545	41365	39683	40528	41373	39750	40595	41440
	(Low)	(Mid)	(High)	(Low)	(Mid)	(High)	(Low)	(Mid)	(High)
Channel SCC	39875	40695	41515	39800	40645	41490	39867	40712	41557
	(Low)	(Mid)	(High)	(Low)	(Mid)	(High)	(Low)	(Mid)	(High)
Conducted Power (dBm)	23.71	22.73	22.68	23.62	22.94	23.08	23.59	23.01	22.96
Conducted Power (Watts)	0.2350	0.1875	0.1854	0.2301	0.1968	0.2032	0.2286	0.2000	0.1977
EIRP(dBm)	26.73	25.75	25.70	26.64	25.96	26.10	26.61	26.03	25.98
EIRP(Watts)	0.4710	0.3758	0.3715	0.4613	0.3945	0.4074	0.4581	0.4009	0.3963

LTE Band 41 CA (GT - LC = 3.02 dB) 64QAM									
Bandwidth	10M + 20M			20M + 10M			15M + 20M		
Channel PCC	39705	40526	41346	39750	40571	41391	39728	40523	41319
	(Low)	(Mid)	(High)	(Low)	(Mid)	(High)	(Low)	(Mid)	(High)
Channel SCC	39849	40670	41490	39894	40715	41535	39899	40694	41490
	(Low)	(Mid)	(High)	(Low)	(Mid)	(High)	(Low)	(Mid)	(High)
Conducted Power (dBm)	23.56	23.08	23.03	23.53	23.04	22.99	23.50	23	22.95
Conducted Power (Watts)	0.2270	0.2032	0.2009	0.2254	0.2014	0.1991	0.2239	0.1995	0.1972
EIRP(dBm)	26.58	26.10	26.05	26.55	26.06	26.01	26.52	26.02	25.97
EIRP(Watts)	0.4550	0.4074	0.4027	0.4519	0.4036	0.3990	0.4487	0.3999	0.3954



LTE Band 41 CA (GT - LC = 3.02 dB) 64QAM						
Bandwidth	20M+15M			20M+20M		
Channel PCC	39750	40546	41341	39750	40521	41292
	(Low)	(Mid)	(High)	(Low)	(Mid)	(High)
Channel SCC	39921	40717	41512	39948	40719	41490
	(Low)	(Mid)	(High)	(Low)	(Mid)	(High)
Conducted Power (dBm)	23.47	22.96	22.91	23.02	23.71	23.69
Conducted Power (Watts)	0.2223	0.1977	0.1954	0.2004	0.2350	0.2339
EIRP(dBm)	26.49	25.98	25.93	26.04	26.73	26.71
EIRP(Watts)	0.4457	0.3963	0.3917	0.4018	0.4710	0.4688

LTE Band 41 CA (GT - LC = 3.02 dB) 64QAM						
Bandwidth	15M+10M			10M+15M		
Channel PCC	39725	40571	41417	39703	40549	41395
	(Low)	(Mid)	(High)	(Low)	(Mid)	(High)
Channel SCC	39845	40691	41537	39823	40669	41490
	(Low)	(Mid)	(High)	(Low)	(Mid)	(High)
Conducted Power (dBm)	23.65	22.87	22.82	23.68	22.8	22.75
Conducted Power (Watts)	0.2317	0.1936	0.1914	0.2333	0.1905	0.1884
EIRP(dBm)	26.67	25.89	25.84	26.70	25.82	25.77
EIRP(Watts)	0.4645	0.3882	0.3837	0.4677	0.3819	0.3776



LTE Band 13

Peak-to-Average Ratio

Mode	LTE Band 13 / 10MHz				
Mod.	QPSK		16QAM		Limit: 13dB
RB Size	1RB	Full RB	1RB	Full RB	Result
Lowest CH	-	-	-	-	PASS
Middle CH	3.48	4.84	4.29	5.62	
Highest CH	-	-	-	-	
Mode	LTE Band 13 / 10MHz				
Mod.	64QAM				Limit: 13dB
RB Size	1RB	Full RB			Result
Lowest CH	-	-	-	-	PASS
Middle CH	4.12	5.59	-	-	
Highest CH	-	-	-	-	



LTE Band 13 / 10MHz / QPSK

Middle Channel / 1RB

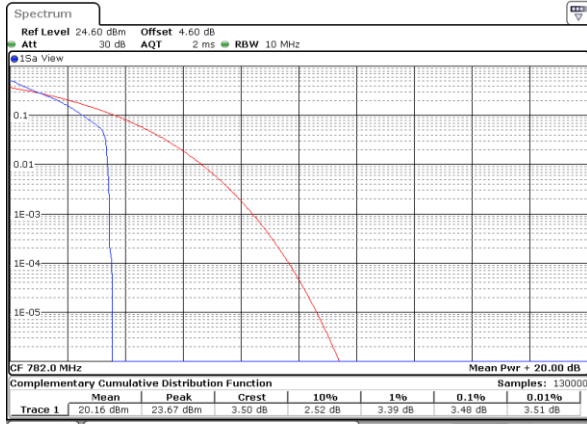

Date: 4 MAY 2020 17:20:09

Middle Channel / Full RB

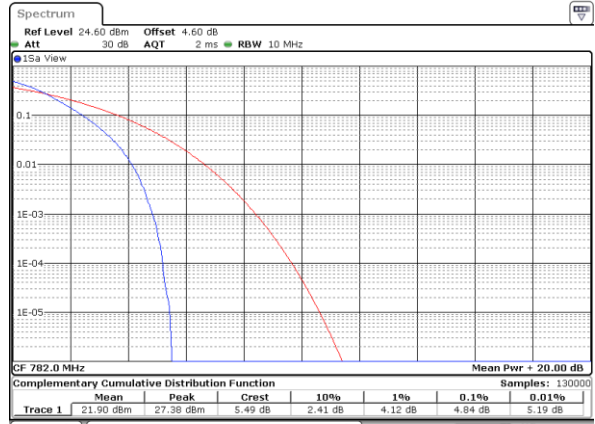

Date: 4 MAY 2020 17:20:37

LTE Band 13 / 10MHz / 16QAM

Middle Channel / 1RB

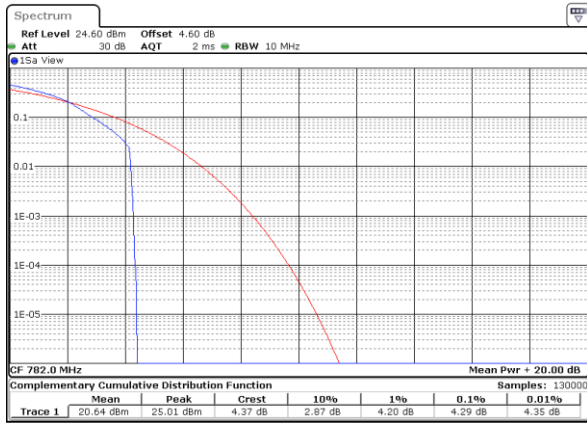

Date: 4 MAY 2020 17:20:18

Middle Channel / Full RB



Date: 4 MAY 2020 17:20:28

LTE Band 13 / 10MHz / 64QAM

Middle Channel / 1RB

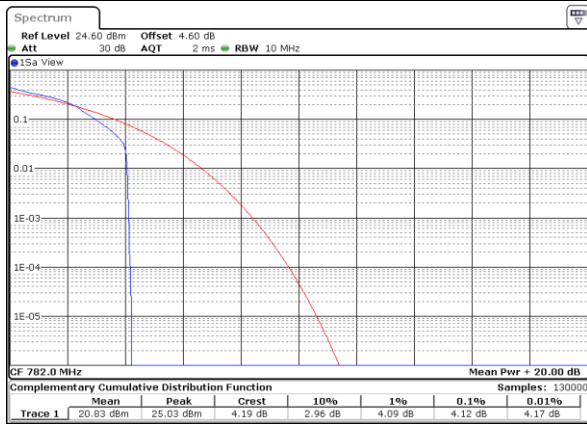

Date: 4 MAY 2020 17:39:04

Middle Channel / Full RB

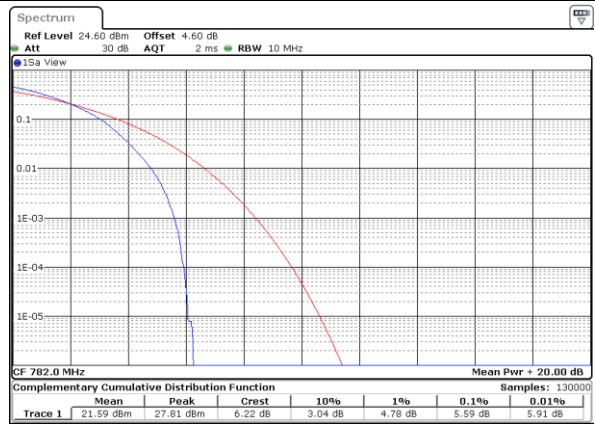

Date: 4 MAY 2020 17:39:37



26dB Bandwidth

Mode	LTE Band 13 : 26dB BW(MHz)											
BW	1.4MHz		3MHz		5MHz		10MHz		15MHz		20MHz	
Mod.	QPSK	16QAM	QPSK	16QAM	QPSK	16QAM	QPSK	16QAM	QPSK	16QAM	QPSK	16QAM
Lowest CH	-	-	-	-	4.83	4.85	-	-	-	-	-	-
Middle CH	-	-	-	-	4.84	4.92	9.75	9.63	-	-	-	-
Highest CH	-	-	-	-	4.94	4.88	-	-	-	-	-	-
Mode	LTE Band 13 : 26dB BW(MHz)											
BW	1.4MHz		3MHz		5MHz		10MHz		15MHz		20MHz	
Mod.	64QAM		64QAM		64QAM		64QAM		64QAM		64QAM	
Lowest CH	-	-	-	-	4.92	-	-	-	-	-	-	-
Middle CH	-	-	-	-	4.92	-	9.71	-	-	-	-	-
Highest CH	-	-	-	-	4.91	-	-	-	-	-	-	-



LTE Band 13

Lowest Channel / 5MHz / QPSK

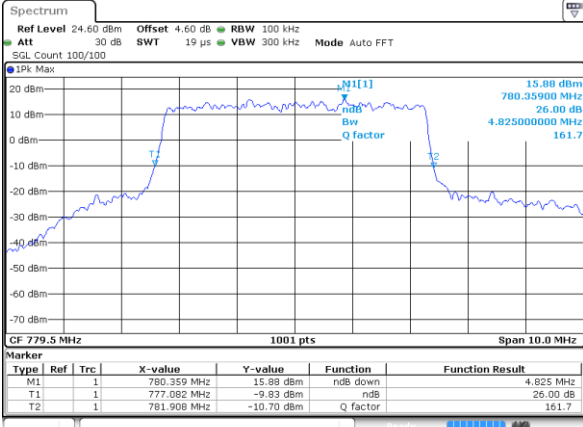

Date: 4 MAY 2020 16:33:32

Lowest Channel / 5MHz / 16QAM

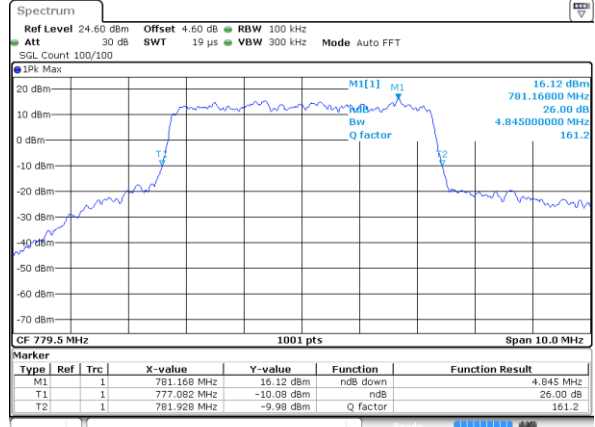

Date: 4 MAY 2020 16:33:42

Middle Channel / 5MHz / QPSK

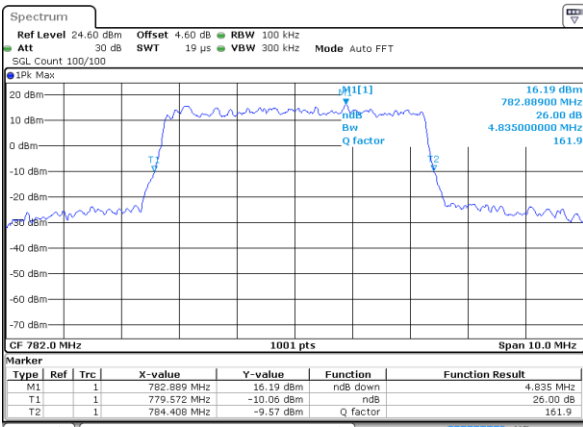

Date: 4 MAY 2020 16:42:32

Middle Channel / 5MHz / 16QAM

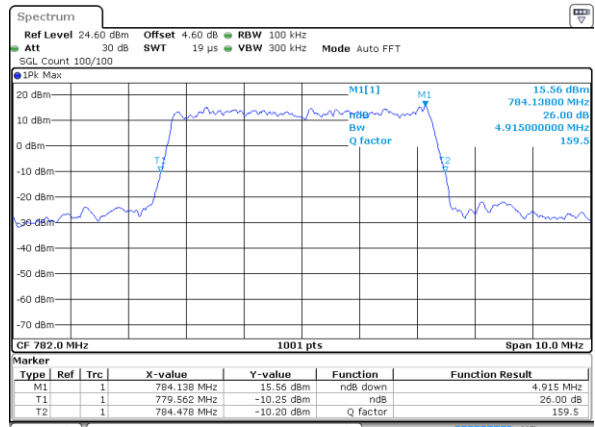

Date: 4 MAY 2020 16:42:42

Highest Channel / 5MHz / QPSK

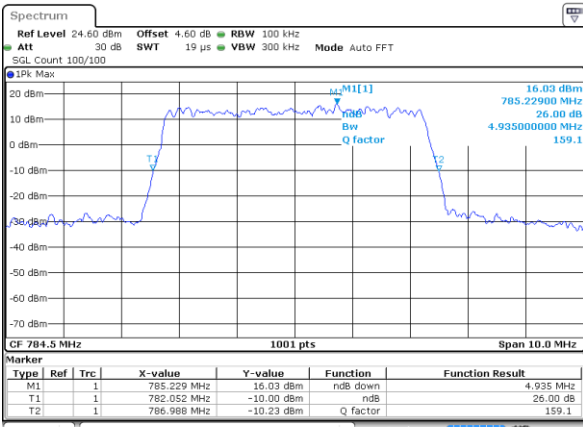

Date: 4 MAY 2020 16:45:11

Highest Channel / 5MHz / 16QAM

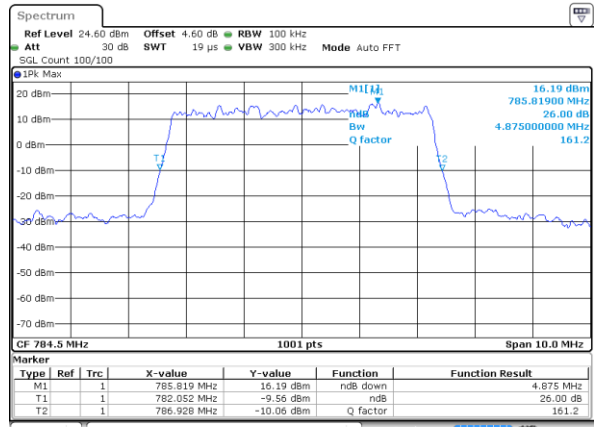

Date: 4 MAY 2020 16:45:01



LTE Band 13

Middle Channel / 10MHz / QPSK

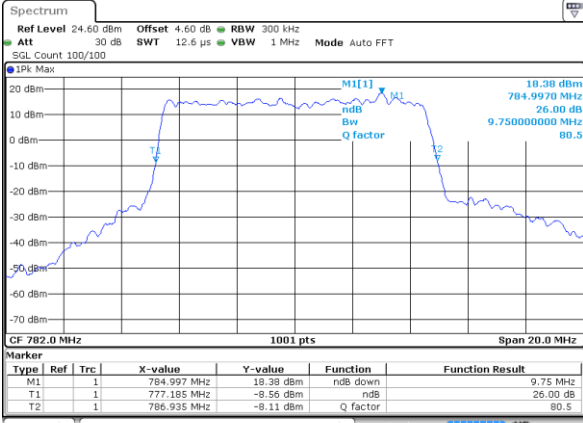

Date: 4 MAY 2020 16:56:00

Middle Channel / 10MHz / 16QAM

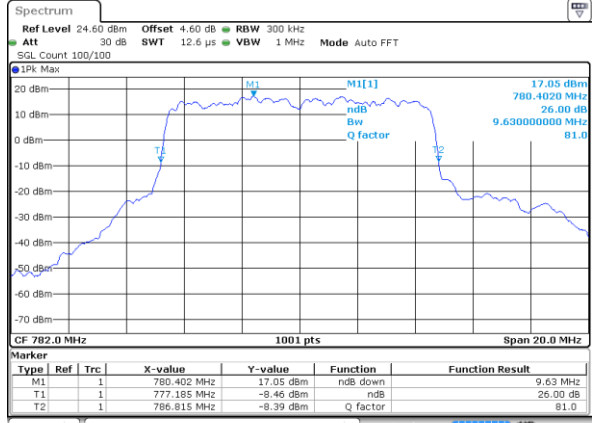

Date: 4 MAY 2020 16:55:50



LTE Band 13

Lowest Channel / 5MHz / 64QAM

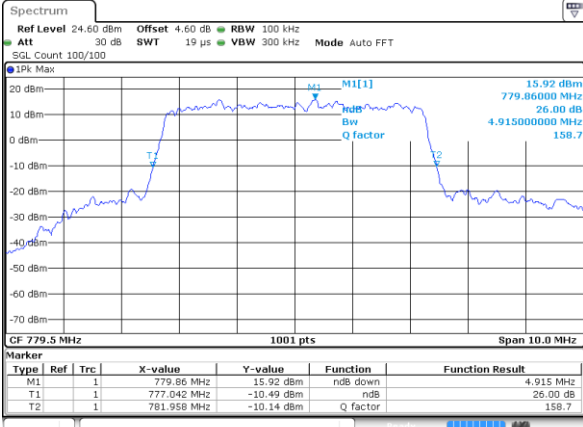

Date: 4 MAY 2020 17:21:17

Middle Channel / 5MHz / 64QAM

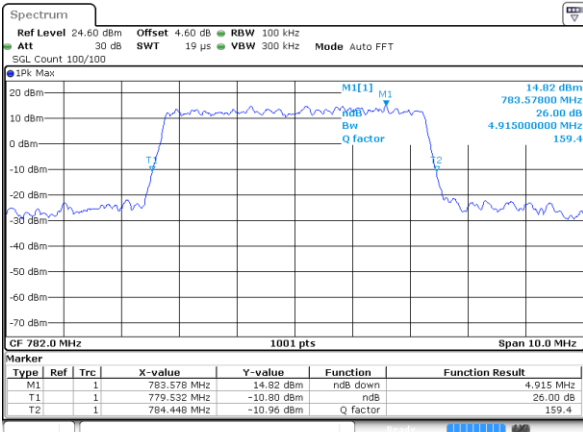

Date: 4 MAY 2020 17:21:27

Middle Channel / 10MHz / 64QAM

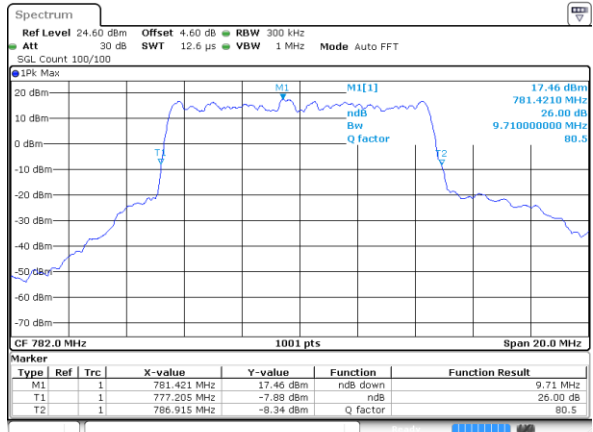

Date: 4 MAY 2020 17:31:11

Highest Channel / 5MHz / 64QAM

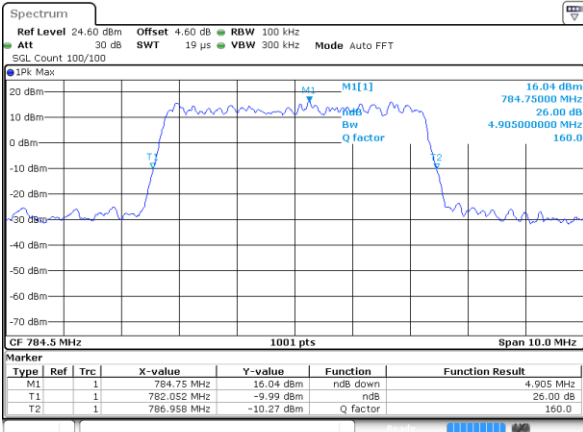

Date: 4 MAY 2020 17:21:38



Occupied Bandwidth

Mode	LTE Band 13 : 99%OBW(MHz)											
BW	1.4MHz		3MHz		5MHz		10MHz		15MHz		20MHz	
Mod.	QPSK	16QAM	QPSK	16QAM	QPSK	16QAM	QPSK	16QAM	QPSK	16QAM	QPSK	16QAM
Lowest CH	-	-	-	-	4.49	4.48	-	-	-	-	-	-
Middle CH	-	-	-	-	4.49	4.49	9.01	8.95	-	-	-	-
Highest CH	-	-	-	-	4.51	4.49	-	-	-	-	-	-
Mode	LTE Band 13 : 99%OBW(MHz)											
BW	1.4MHz		3MHz		5MHz		10MHz		15MHz		20MHz	
Mod.	64QAM		64QAM		64QAM		64QAM		64QAM		64QAM	
Lowest CH	-	-	-	-	4.49	-	-	-	-	-	-	-
Middle CH	-	-	-	-	4.49	-	8.97	-	-	-	-	-
Highest CH	-	-	-	-	4.50	-	-	-	-	-	-	-



LTE Band 13

Lowest Channel / 5MHz / QPSK

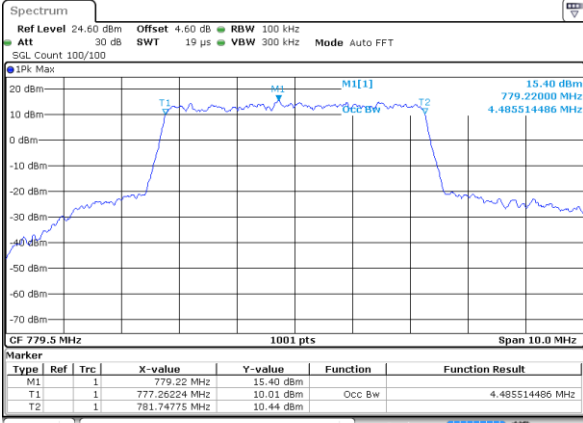

Date: 4 MAY 2020 16:34:02

Lowest Channel / 5MHz / 16QAM

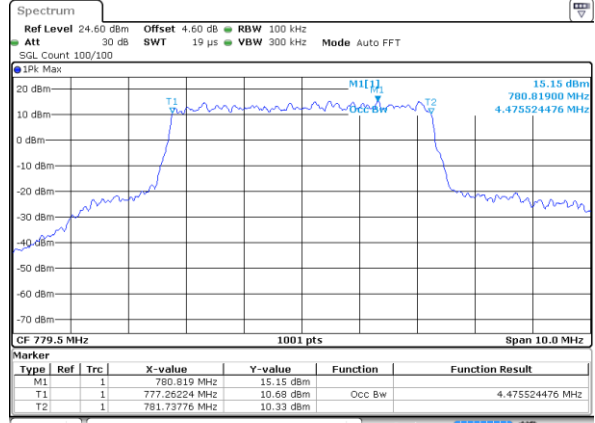

Date: 4 MAY 2020 16:33:52

Middle Channel / 5MHz / QPSK

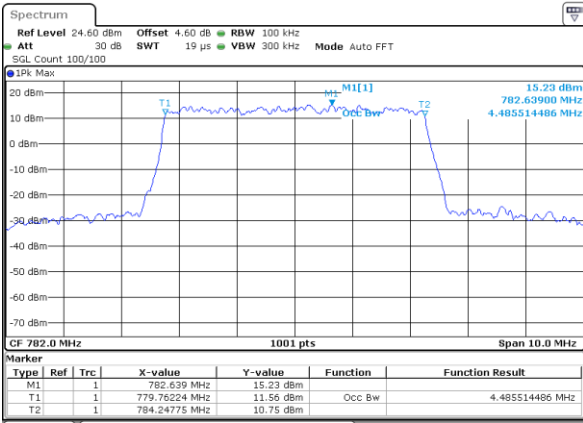

Date: 4 MAY 2020 16:42:52

Middle Channel / 5MHz / 16QAM

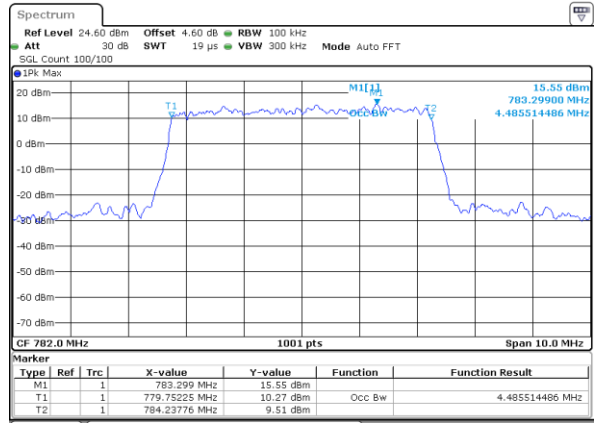

Date: 4 MAY 2020 16:43:02

Highest Channel / 5MHz / QPSK

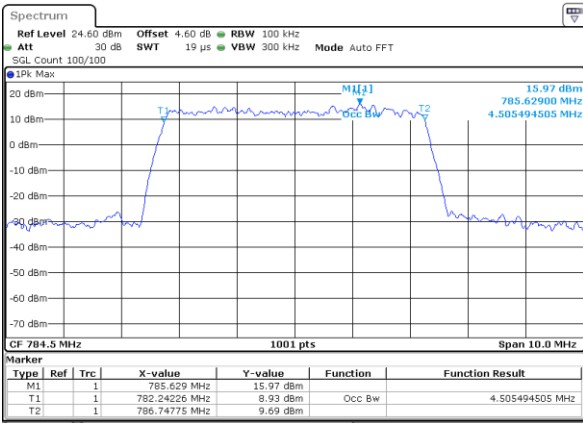

Date: 4 MAY 2020 16:45:21

Highest Channel / 5MHz / 16QAM

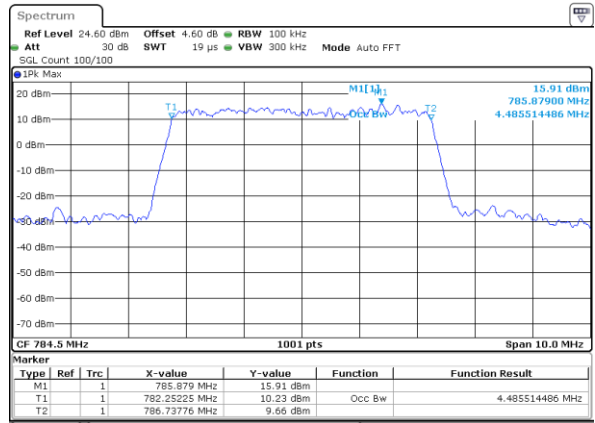

Date: 4 MAY 2020 16:45:31



LTE Band 13

Middle Channel / 10MHz / QPSK

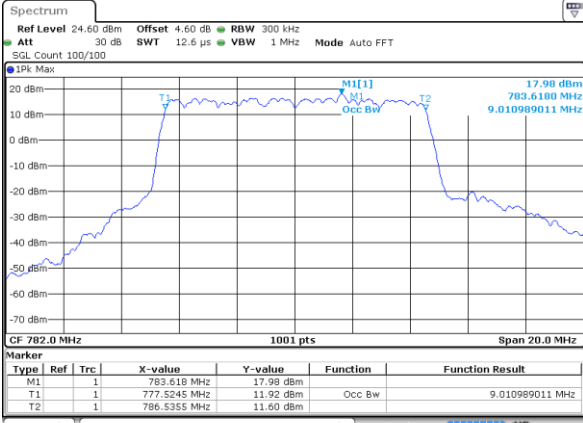

Date: 4 MAY 2020 16:56:10

Middle Channel / 10MHz / 16QAM

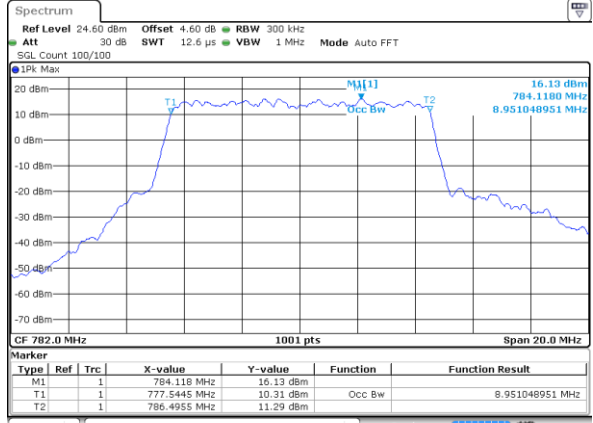

Date: 4 MAY 2020 16:56:20



LTE Band 13

Lowest Channel / 5MHz / 64QAM

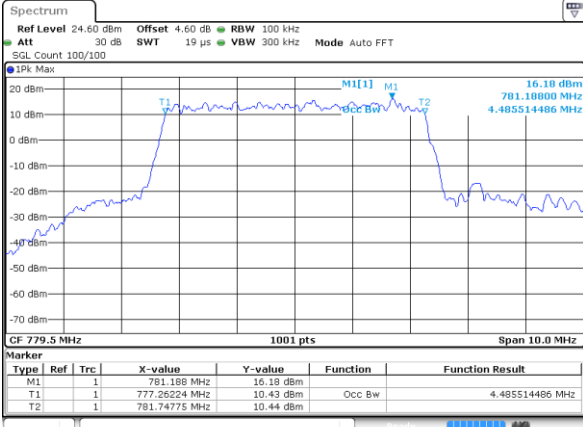

Date: 4 MAY 2020 17:20:47

Middle Channel / 5MHz / 64QAM

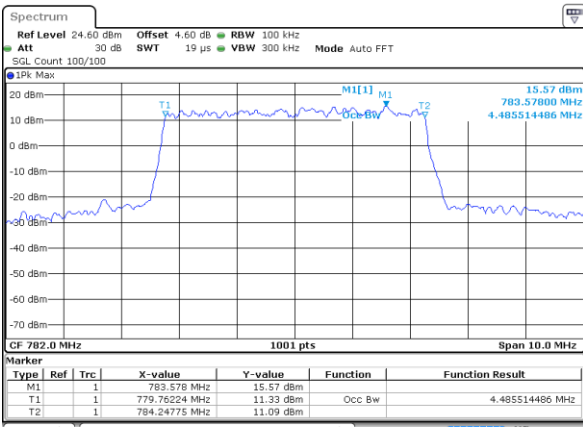

Date: 4 MAY 2020 17:20:57

Middle Channel / 10MHz / 64QAM

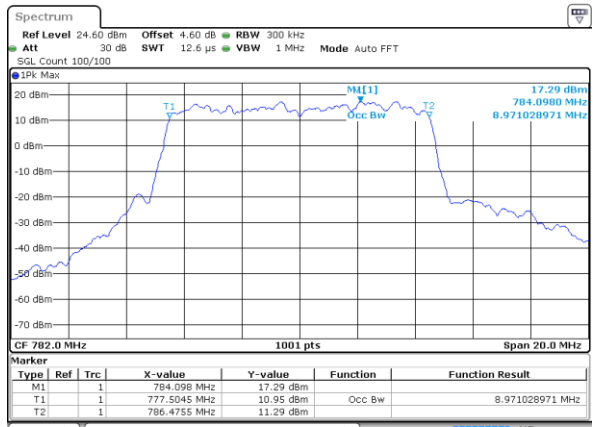

Date: 4 MAY 2020 17:31:01

Highest Channel / 5MHz / 64QAM

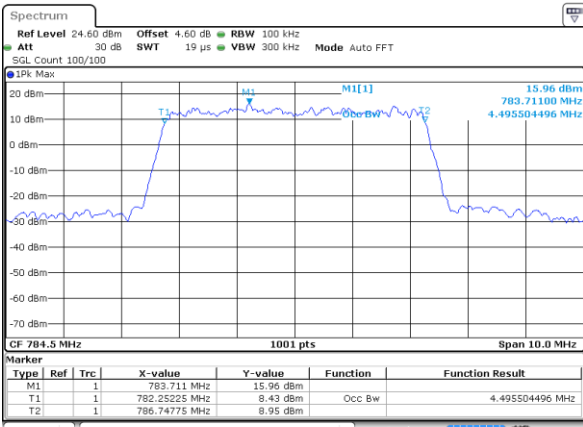

Date: 4 MAY 2020 17:21:07



Conducted Band Edge



LTE Band 13 / 5MHz / QPSK

Lowest Band Edge / 1 RB

Highest Band Edge / 1 RB

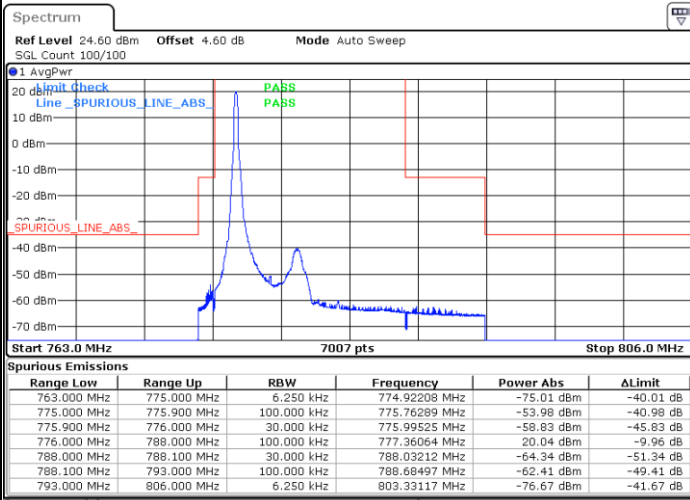

Date: 4 MAY 2020 16:38:55

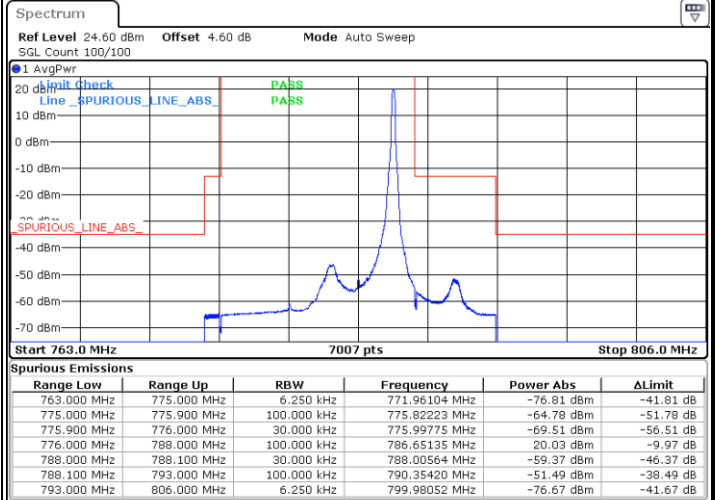

Date: 4 MAY 2020 16:50:25

Lowest Band Edge / Full RB

Highest Band Edge / Full RB

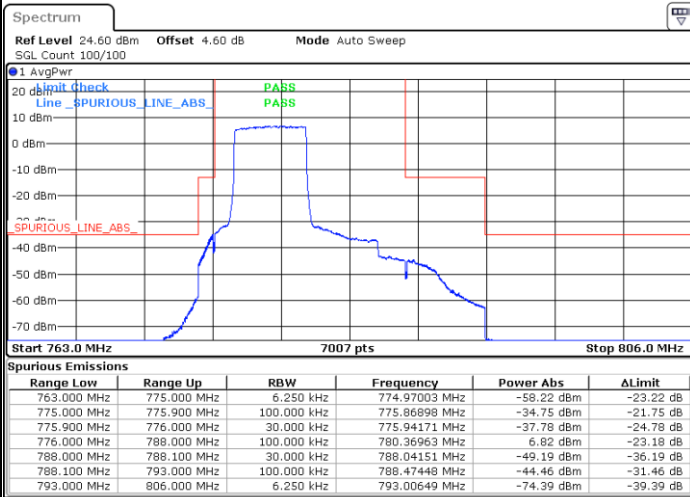

Date: 4 MAY 2020 16:37:18

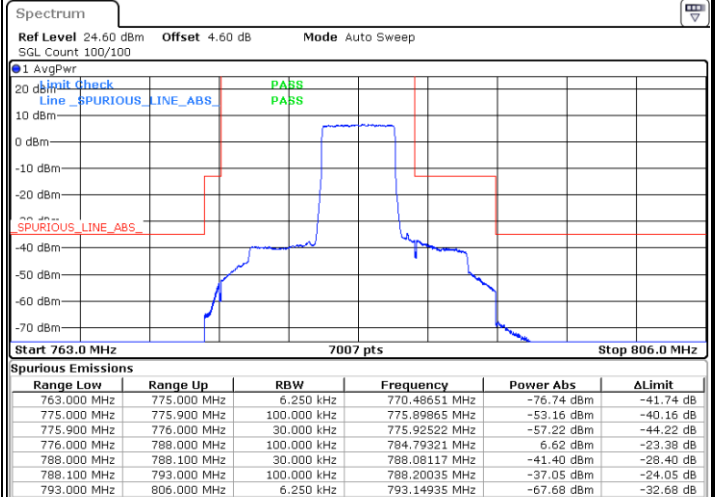

Date: 4 MAY 2020 16:48:47



LTE Band 13 / 5MHz / 16QAM

Lowest Band Edge / 1 RB

Highest Band Edge / 1 RB

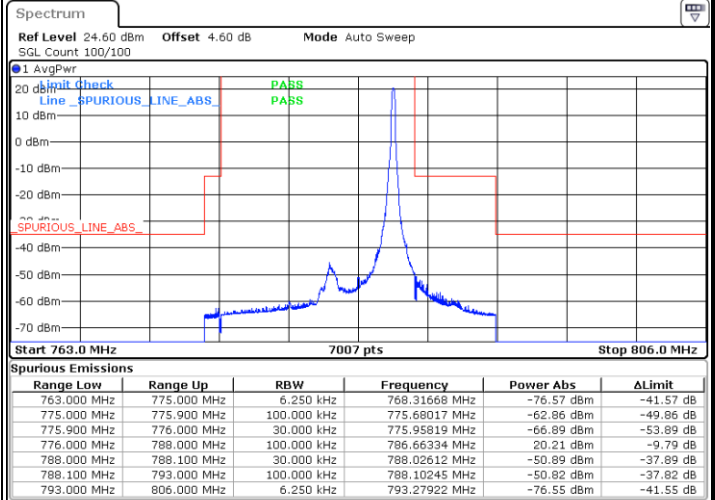
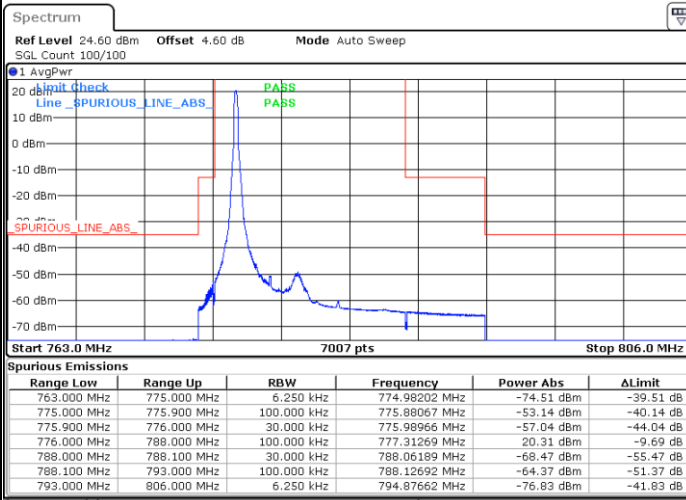

Date: 4 MAY 2020 16:40:33

Date: 4 MAY 2020 16:52:02

Lowest Band Edge / Full RB

Highest Band Edge / Full RB

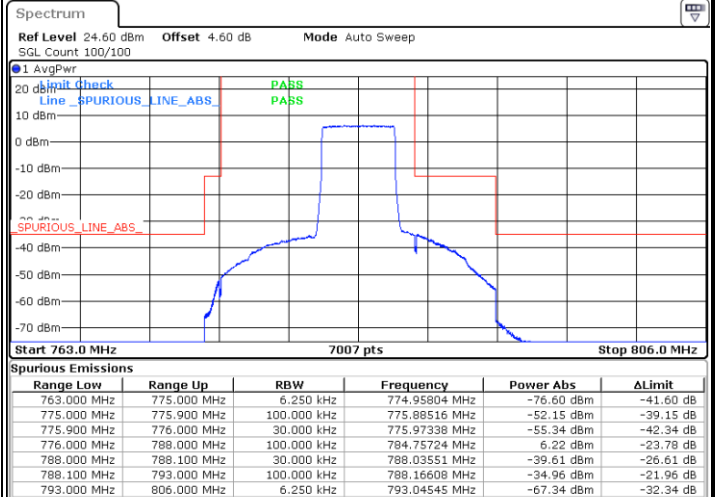
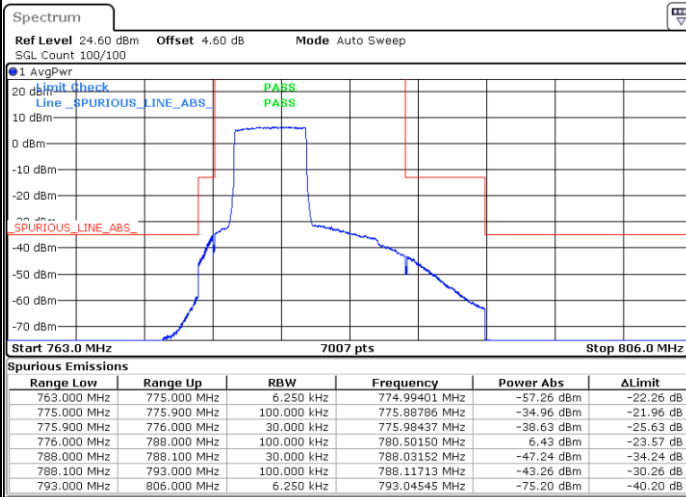

Date: 4 MAY 2020 16:35:40

Date: 4 MAY 2020 16:47:09



LTE Band 13 / 5MHz / 64QAM

Lowest Band Edge / 1 RB

Highest Band Edge / 1 RB

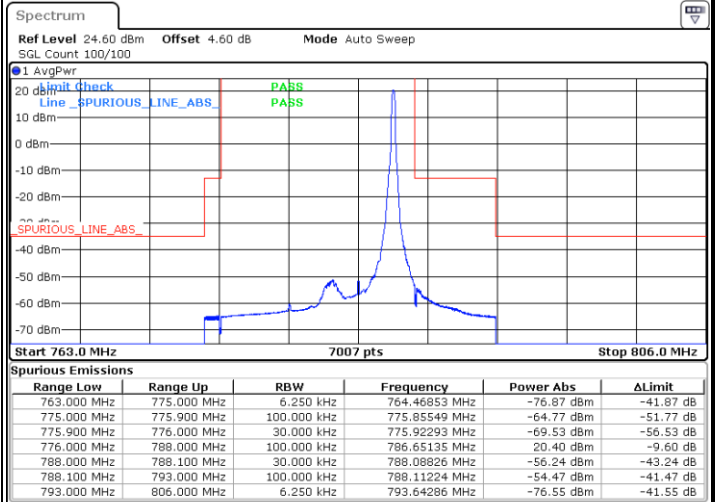
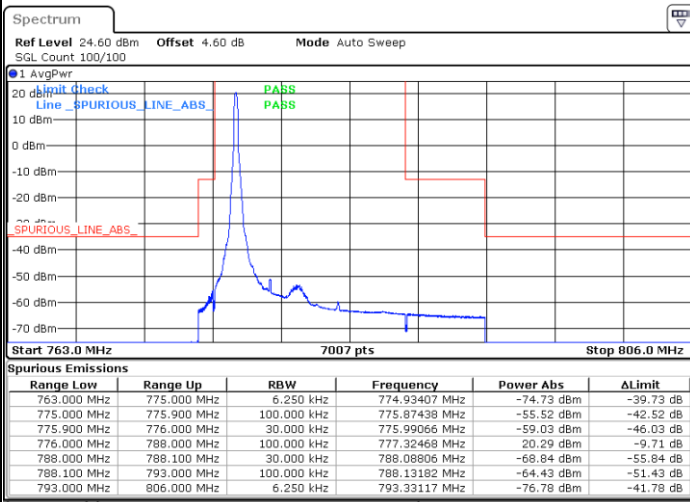

Date: 4 MAY 2020 17:23:15

Date: 4 MAY 2020 17:28:08

Lowest Band Edge / Full RB

Highest Band Edge / Full RB

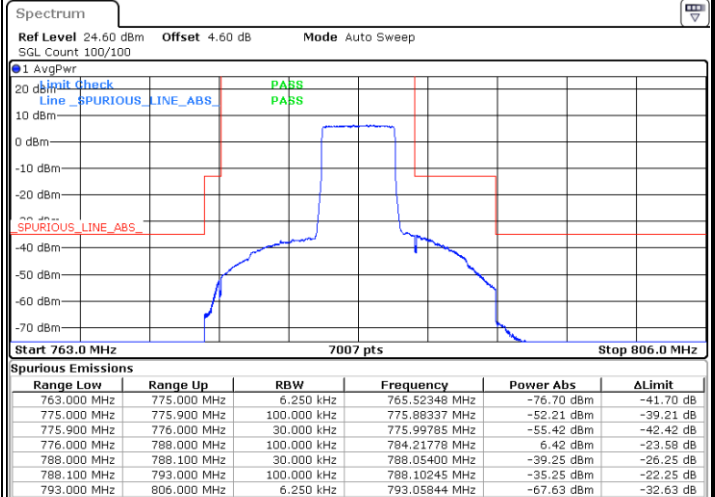
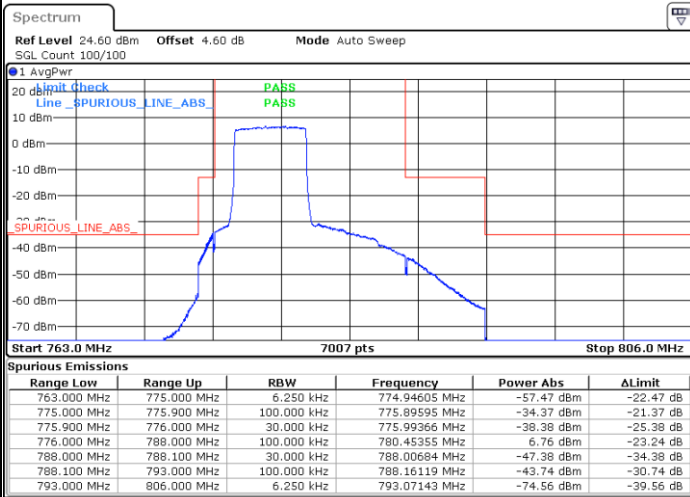

Date: 4 MAY 2020 17:24:53

Date: 4 MAY 2020 17:26:31



LTE Band 13 / 10MHz / QPSK

Lowest Band Edge / 1 RB

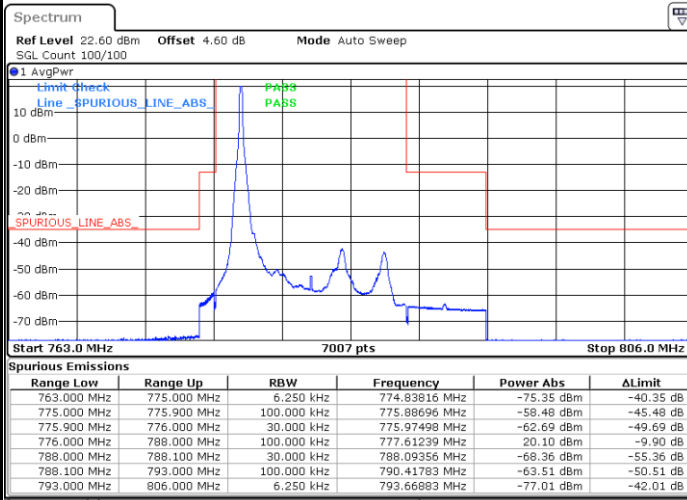

Date: 4.MAY.2020 16:59:36

Highest Band Edge / 1 RB

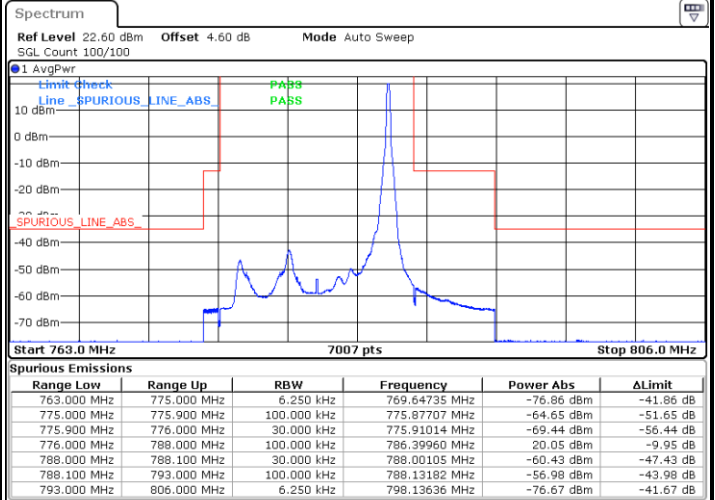

Date: 4.MAY.2020 17:06:06

Band Edge / Full RB

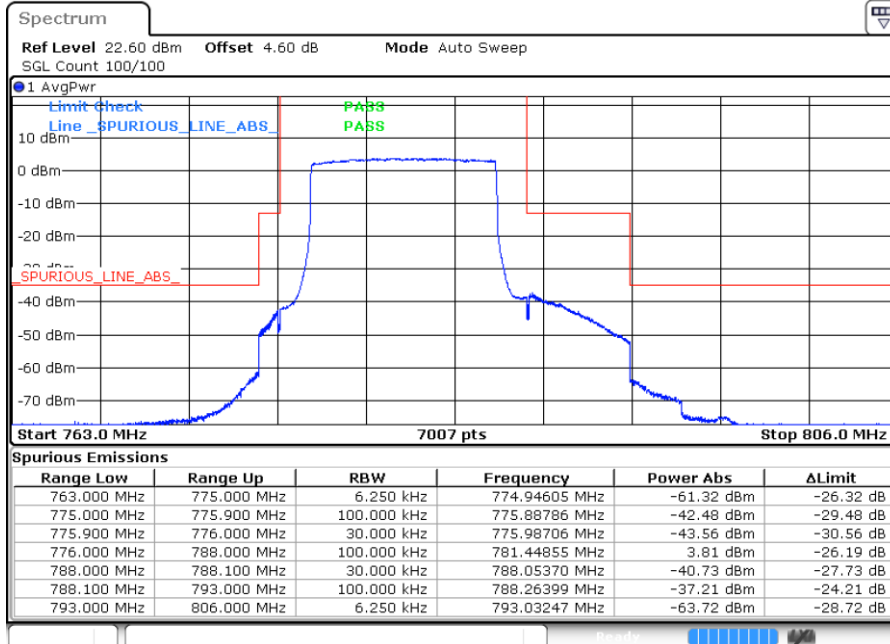

Date: 4.MAY.2020 17:01:13



LTE Band 13 / 10MHz / 16QAM

Lowest Band Edge / 1 RB

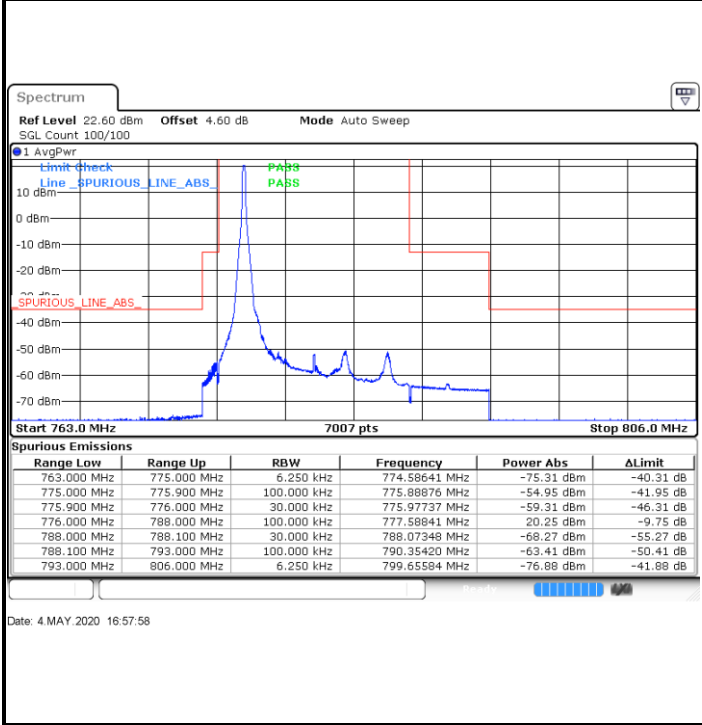

Highest Band Edge / 1 RB

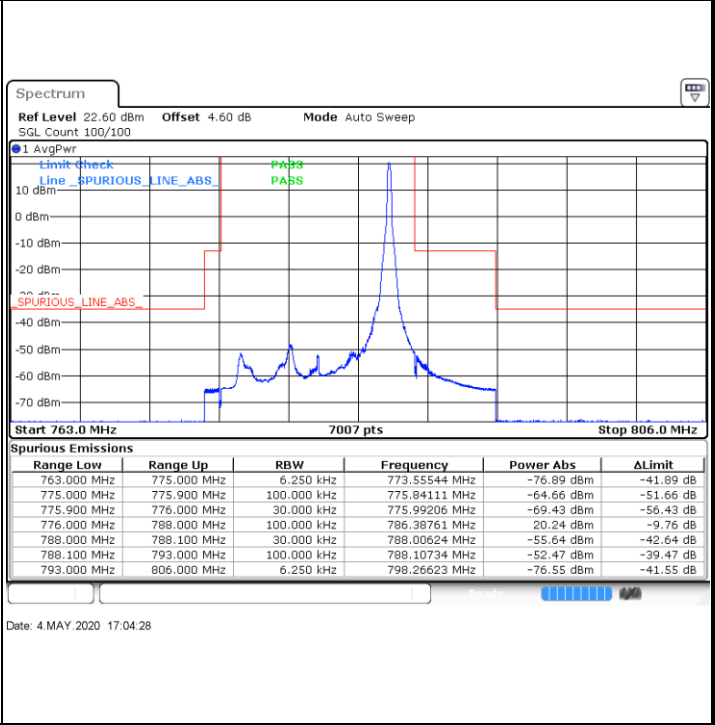

Band Edge / Full RB

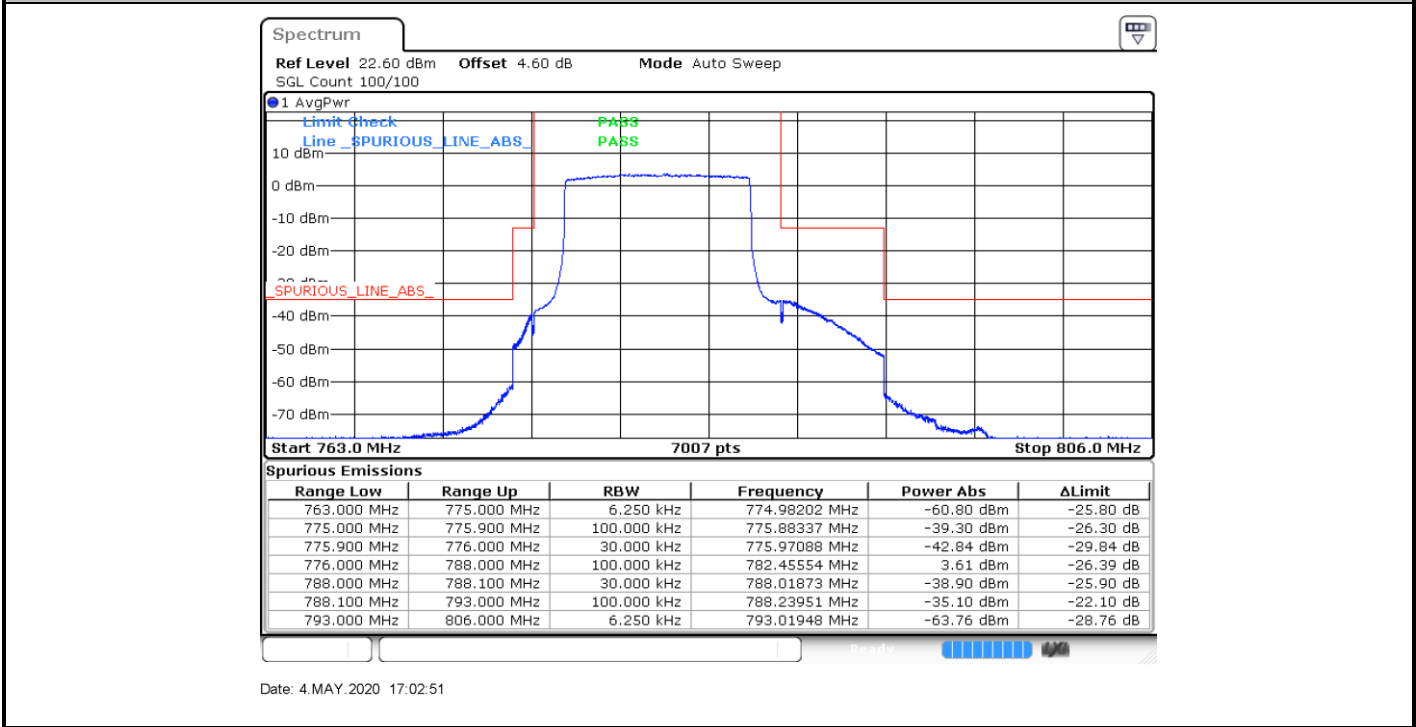



LTE Band 13 / 10MHz / 64QAM

Lowest Band Edge / 1 RB

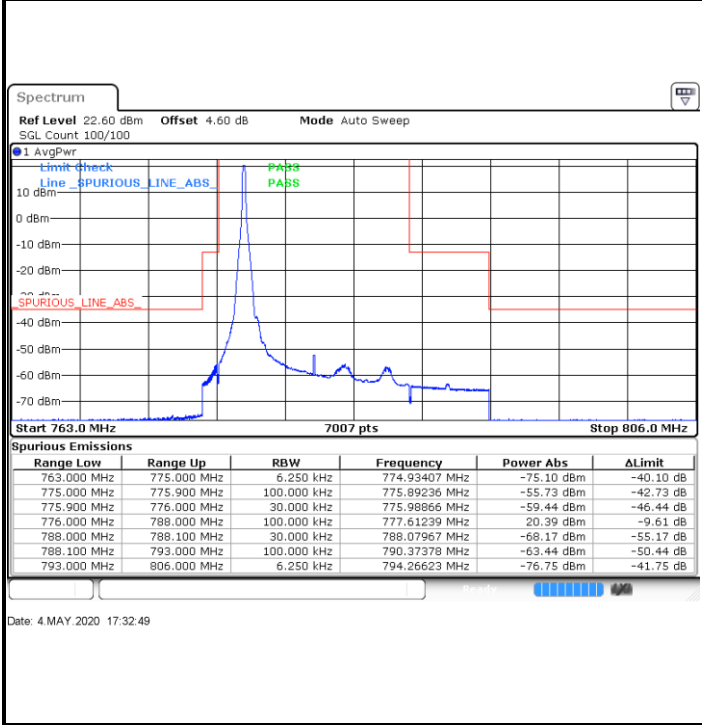

Highest Band Edge / 1 RB

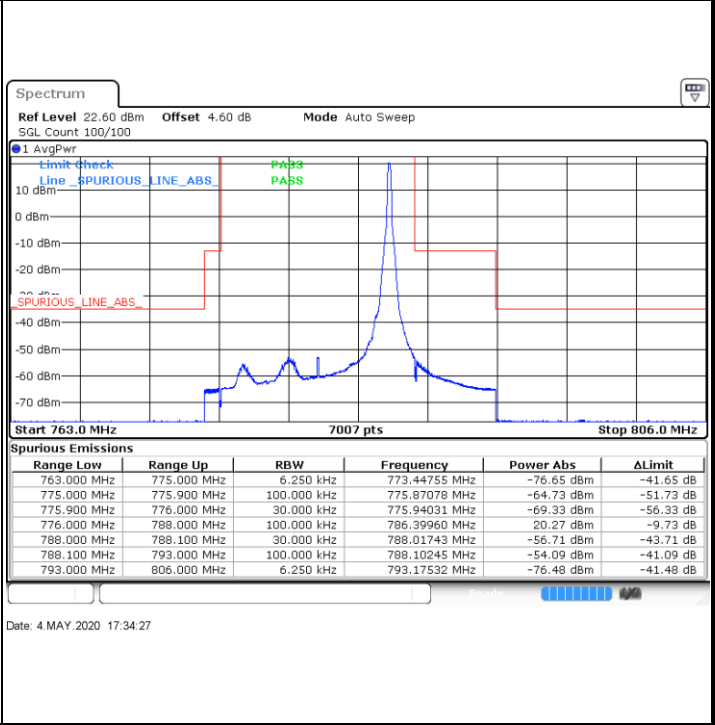

Band Edge / Full RB

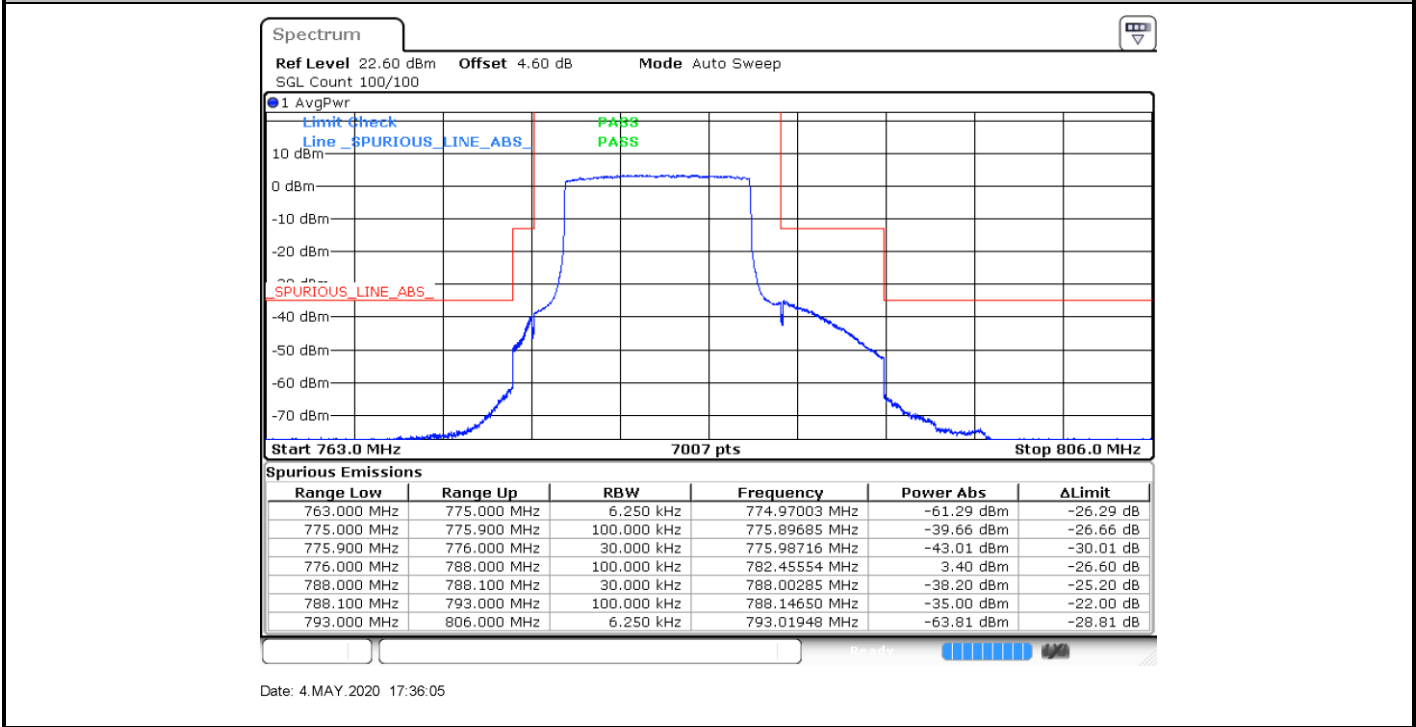



Conducted Spurious Emission



LTE Band 13 / 5MHz

Lowest Channel / QPSK

Lowest Channel / 16QAM

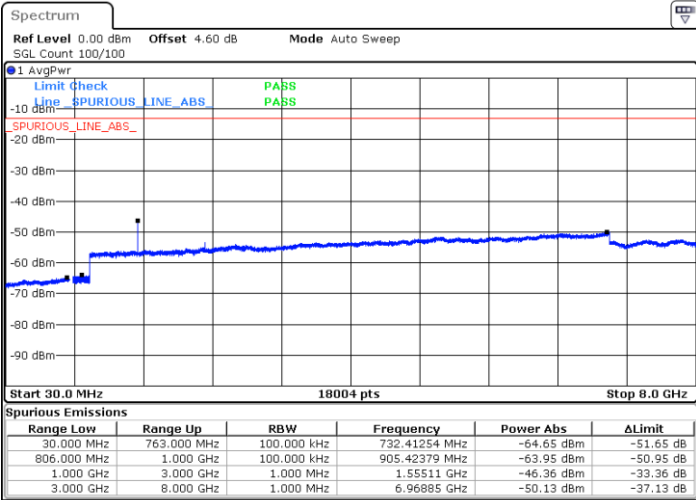

Date: 4 MAY.2020 16:42:21

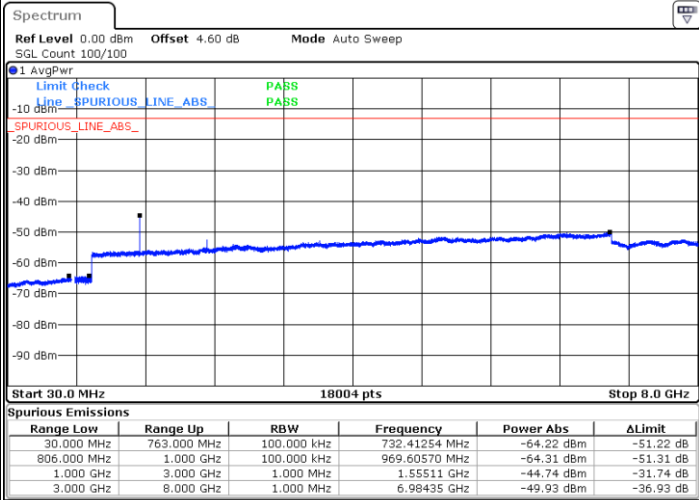

Date: 4 MAY.2020 16:41:27

Middle Channel / QPSK

Middle Channel / 16QAM

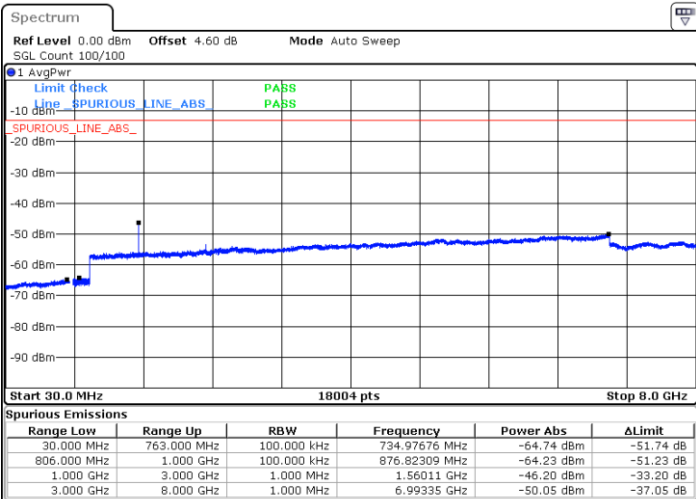

Date: 4 MAY.2020 16:43:56

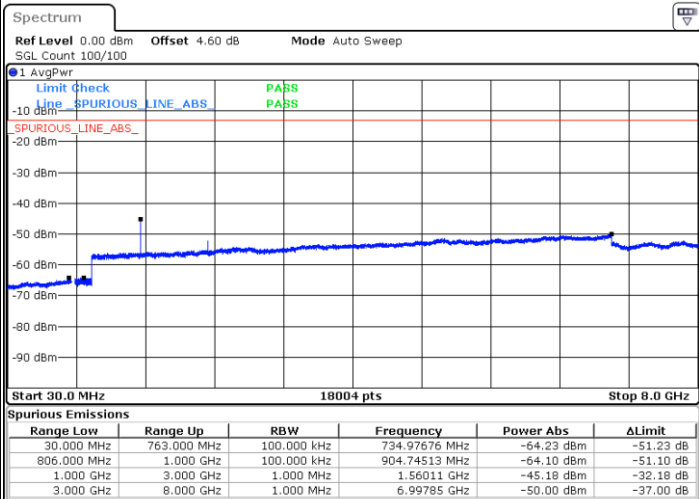

Date: 4 MAY.2020 16:44:50



LTE Band 13 / 5MHz

Highest Channel / QPSK

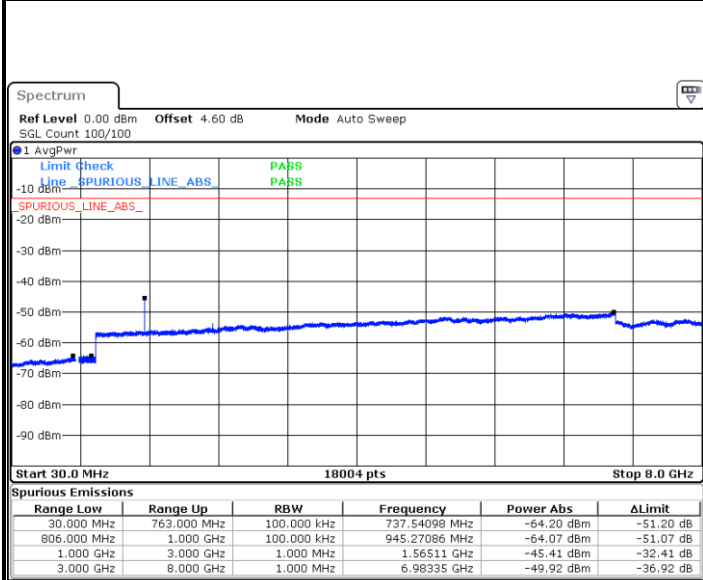

Date: 4 MAY 2020 16:53:50

Highest Channel / 16QAM

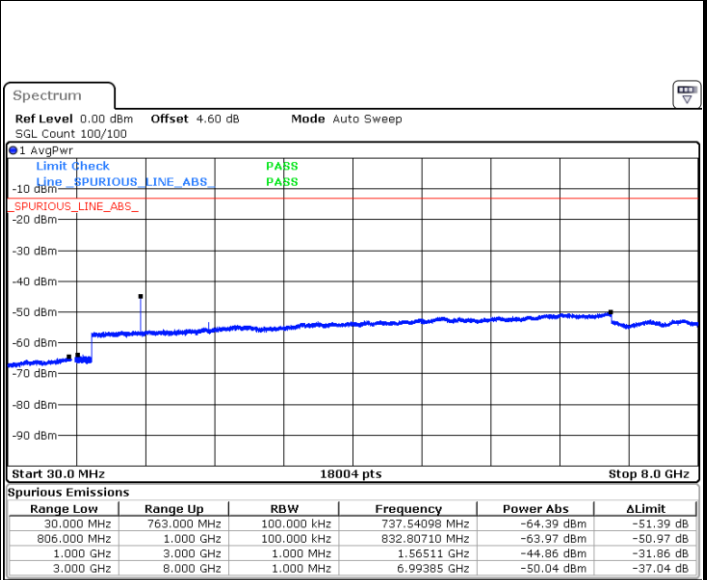

Date: 4 MAY 2020 16:52:56

LTE Band 13 / 10MHz

Middle Channel / QPSK

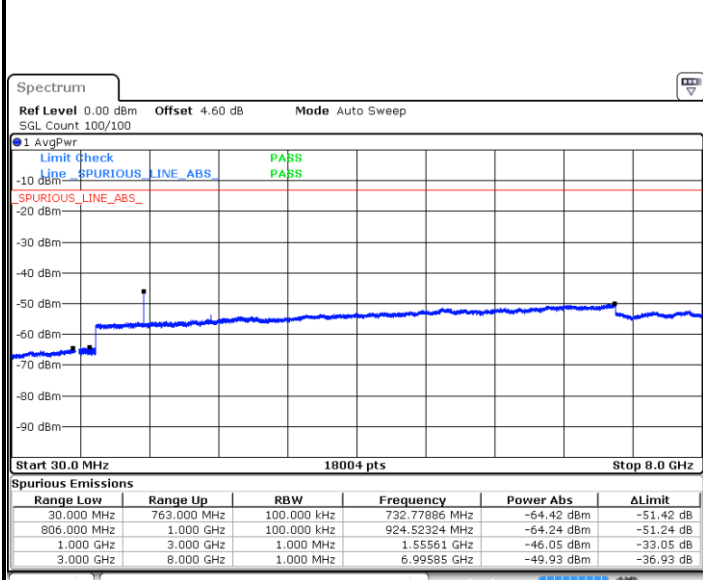

Date: 4 MAY 2020 16:54:45

Middle Channel / 16QAM

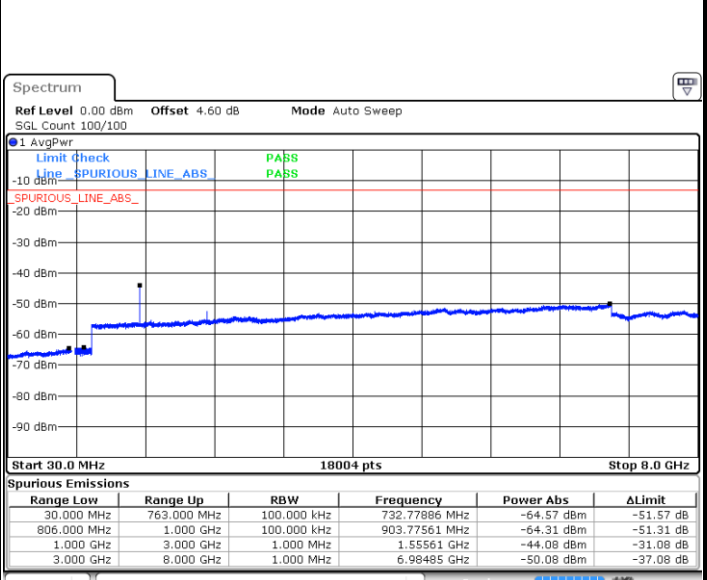

Date: 4 MAY 2020 16:55:39



LTE Band 13 / 10MHz

Middle Channel / 64QAM

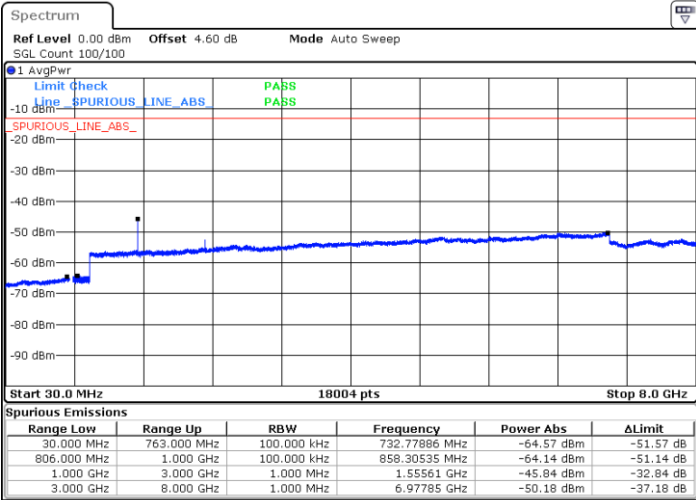

Date: 4.MAY.2020 17:36:58



Frequency Stability

Test Conditions		LTE Band 13 (QPSK) / Middle Channel	Limit
Temperature (°C)	Voltage (Volt)	BW 10MHz	Note 2.
		Deviation (ppm)	Result
50	Normal Voltage	0.0033	PASS
40	Normal Voltage	0.0015	
30	Normal Voltage	0.0028	
20(Ref.)	Normal Voltage	0.0000	
10	Normal Voltage	0.0019	
0	Normal Voltage	0.0025	
-10	Normal Voltage	0.0014	
-20	Normal Voltage	0.0023	
-30	Normal Voltage	0.0015	
20	Maximum Voltage	0.0007	
20	Normal Voltage	0.0016	
20	Battery End Point	0.0022	

Note:

1. Normal Voltage =3.8 V. ; Battery End Point (BEP) =3.4 V. ; Maximum Voltage =4.4 V.
2. Note: The frequency fundamental emissions stay within the authorized frequency block.



LTE Band 25

Peak-to-Average Ratio

Mode	LTE Band 25 / 20MHz				
Mod.	QPSK		16QAM		Limit: 13dB
RB Size	1RB	Full RB	1RB	Full RB	Result
Lowest CH	3.68	4.75	4.93	5.80	PASS
Middle CH	3.54	4.81	4.38	5.74	
Highest CH	3.48	4.93	3.86	5.80	
Mode	LTE Band 25 / 20MHz				
Mod.	64QAM				Limit: 13dB
RB Size	1RB	Full RB			Result
Lowest CH	5.10	5.74	-	-	PASS
Middle CH	4.67	5.83	-	-	
Highest CH	3.97	5.91	-	-	



LTE Band 25 / 20MHz / QPSK

Lowest Channel / 1RB

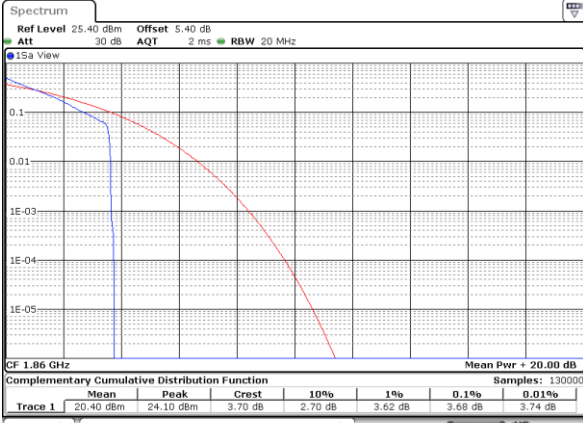

Date: 4 MAY 2020 20:57:01

Lowest Channel / Full RB

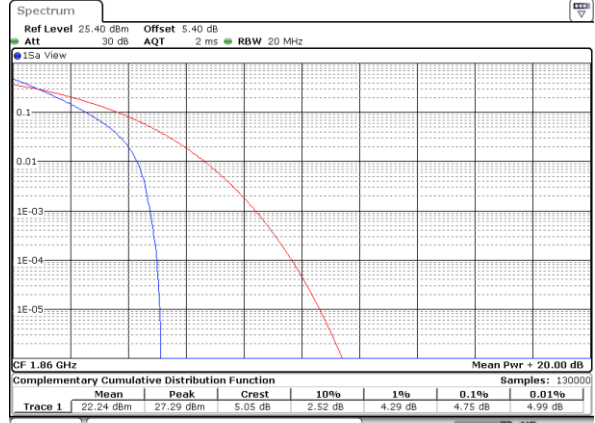

Date: 4 MAY 2020 20:57:59

Middle Channel / 1RB

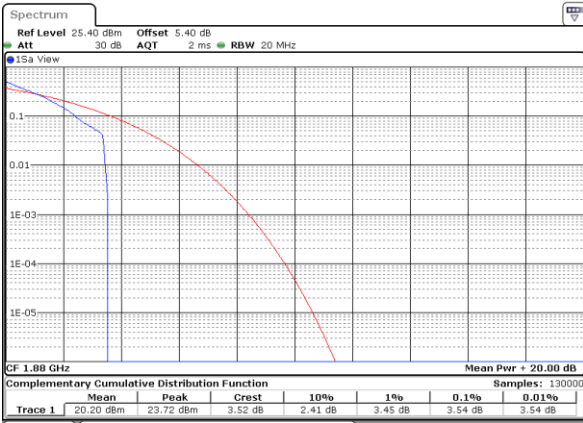

Date: 4 MAY 2020 20:59:07

Middle Channel / Full RB

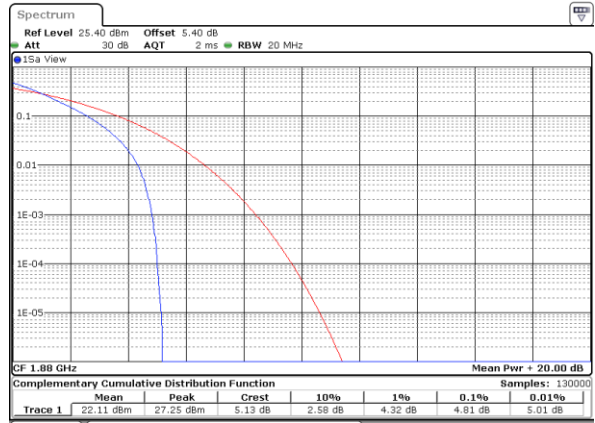

Date: 4 MAY 2020 20:58:10

Highest Channel / 1RB

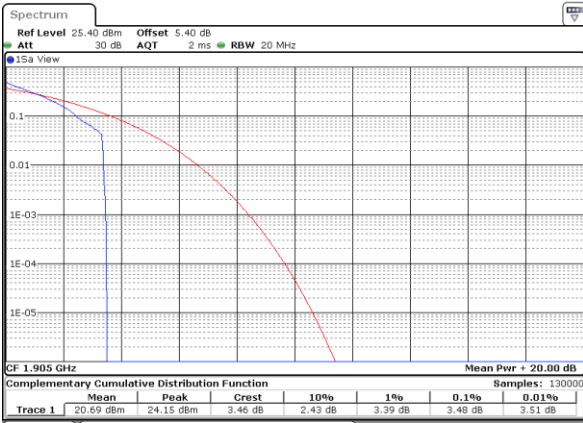

Date: 4 MAY 2020 20:59:16

Highest Channel / Full RB

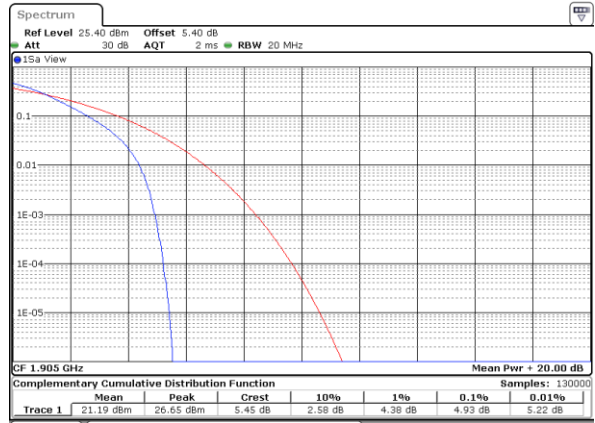

Date: 4 MAY 2020 21:00:04



LTE Band 25 / 20MHz / 16QAM

Lowest Channel / 1RB

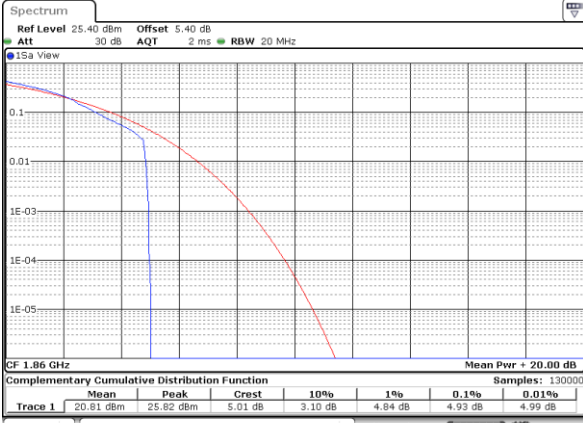

Date: 4 MAY 2020 20:57:21

Lowest Channel / Full RB

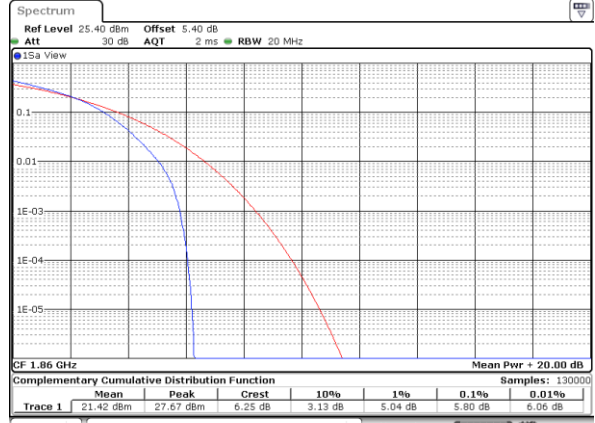

Date: 4 MAY 2020 20:57:50

Middle Channel / 1RB

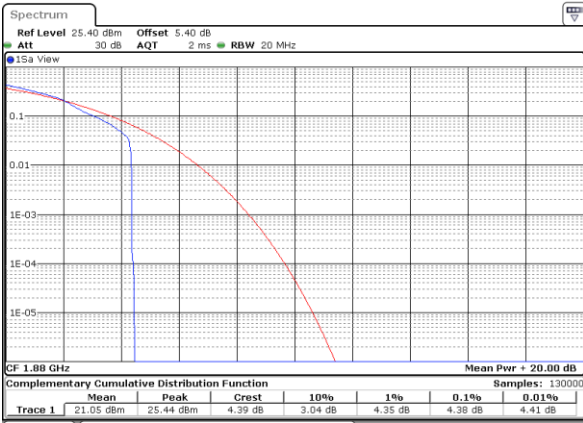

Date: 4 MAY 2020 20:58:51

Middle Channel / Full RB

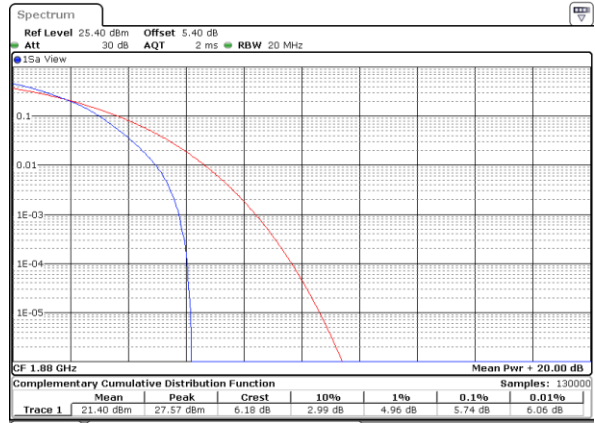

Date: 4 MAY 2020 20:58:20

Highest Channel / 1RB

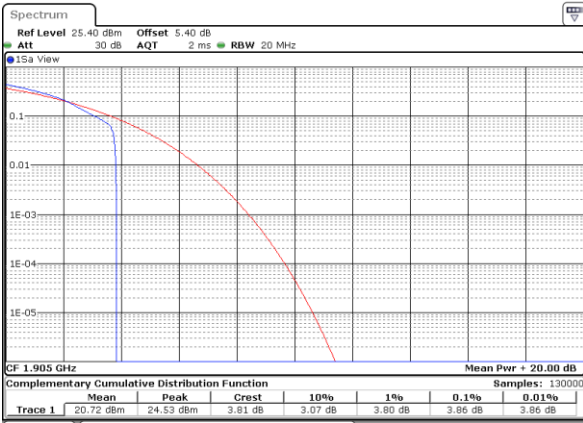

Date: 4 MAY 2020 20:59:25

Highest Channel / Full RB

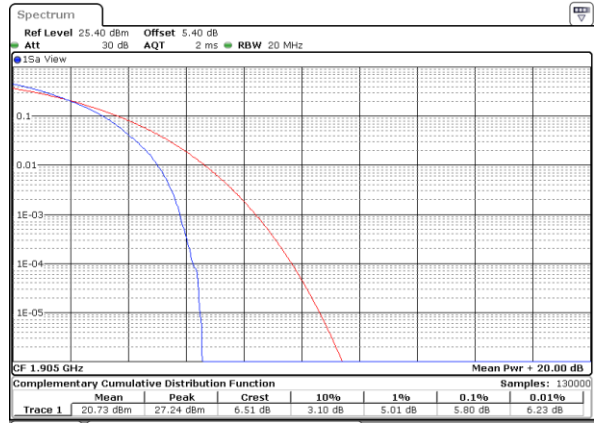

Date: 4 MAY 2020 20:59:54



LTE Band 25 / 20MHz / 64QAM

Lowest Channel / 1RB

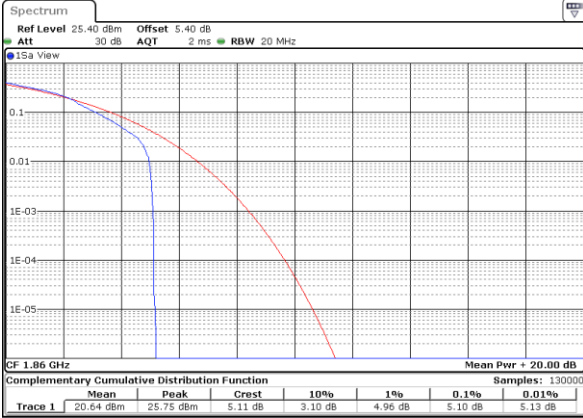

Date: 4 MAY 2020 20:57:32

Lowest Channel / Full RB

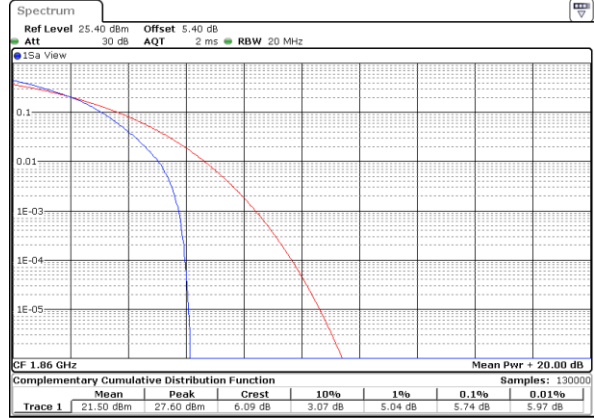

Date: 4 MAY 2020 20:57:41

Middle Channel / 1RB

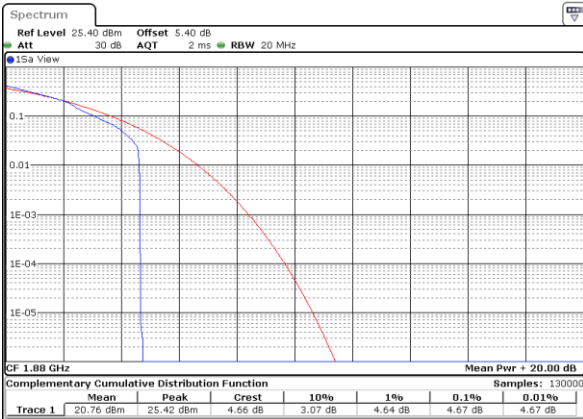

Date: 4 MAY 2020 20:58:41

Middle Channel / Full RB

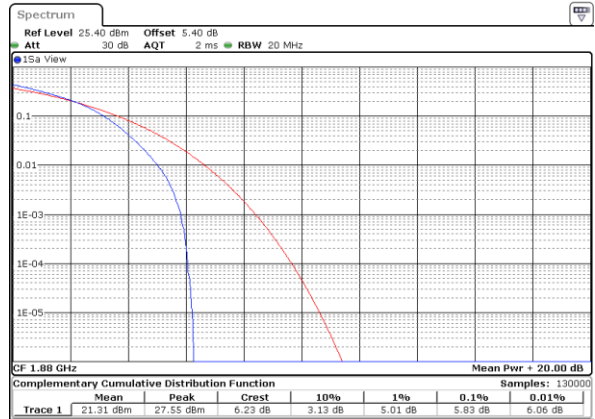

Date: 4 MAY 2020 20:58:31

Highest Channel / 1RB

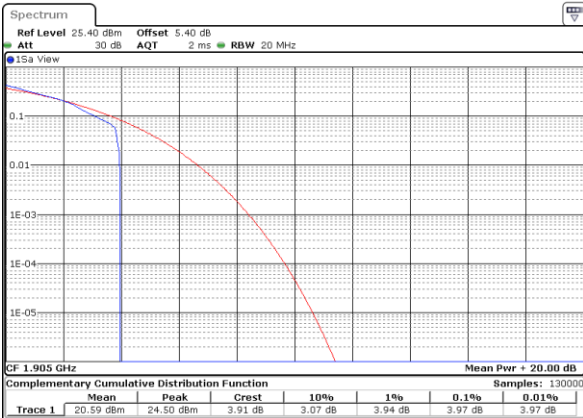

Date: 4 MAY 2020 20:59:35

Highest Channel / Full RB

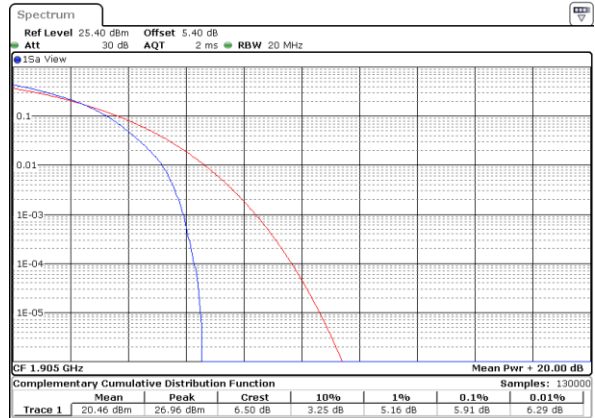

Date: 4 MAY 2020 20:59:45



26dB Bandwidth

Mode	LTE Band 25 : 26dB BW(MHz)											
BW	1.4MHz		3MHz		5MHz		10MHz		15MHz		20MHz	
Mod.	QPSK	16QAM	QPSK	16QAM	QPSK	16QAM	QPSK	16QAM	QPSK	16QAM	QPSK	16QAM
Lowest CH	1.23	1.23	3.03	3.00	4.76	4.88	9.83	9.89	14.33	14.18	20.06	20.26
Middle CH	1.22	1.22	2.96	2.97	4.92	4.76	9.69	9.61	14.39	14.69	20.34	20.18
Highest CH	1.23	1.22	3.05	3.02	4.86	4.95	9.85	9.89	14.42	14.18	20.26	20.22
Mode	LTE Band 25 : 26dB BW(MHz)											
BW	1.4MHz		3MHz		5MHz		10MHz		15MHz		20MHz	
Mod.	64QAM		64QAM		64QAM		64QAM		64QAM		64QAM	
Lowest CH	1.23	-	3.01	-	4.91	-	9.67	-	14.54	-	20.02	-
Middle CH	1.23	-	3.02	-	4.78	-	9.71	-	14.45	-	20.26	-
Highest CH	1.20	-	3.00	-	4.93	-	9.79	-	14.21	-	20.22	-