



FCC RF Test Report

APPLICANT : Motorola Mobility LLC
EQUIPMENT : Mobile Cellular Phone
BRAND NAME : Motorola
MODEL NAME : XT2045-3
FCC ID : IHDT56YK1
STANDARD : 47 CFR Part 2, 22(H), 24(E), 27(L), 27(M), 27(N),
27(H), 27(F)
CLASSIFICATION : PCS Licensed Transmitter Held to Ear (PCE)

The product was received on Jan. 04, 2020 and completely tested on Mar. 09, 2020. We, Sporton International (Kunshan) Inc., would like to declare that the tested sample has been evaluated in accordance with the procedures given in ANSI C63.26-2015 and shown compliance with the applicable technical standards.

The test results in this report apply exclusively to the tested model / sample. Without written approval of Sporton International (Kunshan) Inc., the test report shall not be reproduced except in full.

Reviewed by: Jason Jia / Supervisor

Approved by: James Huang / Manager



Sporton International (Kunshan) Inc.

**No. 1098, Pengxi North Road, Kunshan Economic Development Zone Jiangsu Province 215300
People's Republic of China**



TABLE OF CONTENTS

REVISION HISTORY... 3
SUMMARY OF TEST RESULT ... 4
1 GENERAL DESCRIPTION ... 6
1.1 Applicant ... 6
1.2 Manufacturer ... 6
1.3 Product Feature of Equipment Under Test ... 6
1.4 Product Specification of Equipment Under Test ... 7
1.5 Modification of EUT ... 8
1.6 Maximum ERP/EIRP Power, Frequency Tolerance, and Emission Designator ... 9
1.7 Specification of Accessory ... 18
1.8 Testing Location ... 18
1.9 Test Software ... 18
1.10 Applicable Standards ... 19
2 TEST CONFIGURATION OF EQUIPMENT UNDER TEST ... 20
2.1 Test Mode ... 20
2.2 Connection Diagram of Test System ... 25
2.3 Support Unit used in test configuration and system ... 25
2.4 Measurement Results Explanation Example ... 25
2.5 Frequency List of Low/Middle/High Channels ... 26
3 CONDUCTED TEST ITEMS ... 34
3.1 Measuring Instruments ... 34
3.2 Test Setup ... 34
3.3 Test Result of Conducted Test ... 34
3.4 Conducted Output Power and ERP/EIRP ... 35
3.5 Peak-to-Average Ratio ... 36
3.6 Occupied Bandwidth ... 37
3.7 Conducted Band Edge ... 38
3.8 Conducted Spurious Emission ... 40
3.9 Frequency Stability ... 41
4 RADIATED TEST ITEMS ... 42
4.1 Measuring Instruments ... 42
4.2 Test Setup ... 42
4.3 Test Result of Radiated Test ... 42
4.4 Radiated Spurious Emission ... 43
5 LIST OF MEASURING EQUIPMENT ... 44
6 UNCERTAINTY OF EVALUATION ... 45
APPENDIX A. TEST RESULTS OF CONDUCTED TEST
APPENDIX B. TEST RESULTS OF RADIATED TEST
APPENDIX C. TEST SETUP PHOTOGRAPHS



SUMMARY OF TEST RESULT

Report Section	FCC Rule	Description	Limit	Result	Remark
3.4	§2.1046	Conducted Output Power	Reporting Only	PASS	-
	§22.913(a)(5)	Effective Radiated Power (Band 5) (Band 26)	ERP < 7 Watt	PASS	-
	§27.50(b)(10) §27.50(c)(10)	Effective Radiated Power (Band 12) (Band 13) (Band 17) (Band 71)	ERP < 3 Watt	PASS	-
	§24.232(c) §27.50(h)(2)	Equivalent Isotropic Radiated Power (Band 2) (Band 25) (Band 7) (Band 38) (Band 41)	EIRP < 2Watt	PASS	-
	§27.50(d)(4)	Equivalent Isotropic Radiated Power (Band 4) (Band 66)	EIRP < 1Watt	PASS	-
3.5	§24.232(d)	Peak-to-Average Ratio	<13 dB	PASS	-
3.6	§2.1049	Occupied Bandwidth	Reporting Only	PASS	-
3.7	§2.1051 §22.917(a) §24.238(a) §27.53(c)(2)(4) §27.53(g) §27.53(h)	Conducted Band Edge Measurement (Band 2) (Band 4) (Band 5) (Band 12) (Band 13) (Band 17) (Band 25) (Band 26) (Band 66) (Band 71)	< 43+10log ₁₀ (P[Watts])	PASS	-
	§27.53(m)(4)	Conducted Band Edge Measurement (Band 7) (Band 38) (Band 41)	§27.53(m)(4)		
3.8	§2.1051 §22.917(a) §24.238(a) §27.53(c)(2) §27.53(g) §27.53(h)	Conducted Spurious Emission (Band 2) (Band 4) (Band 5) (Band 12) (Band 13) (Band 17) (Band 25) (Band 26) (Band 66) (Band 71)	< 43+10log ₁₀ (P[Watts])	PASS	-
	§2.1051 §27.53(m)(4)	Conducted Spurious Emission (Band 7) (Band 38) (Band 41)	< 55+10log ₁₀ (P[Watts])		
3.9	§2.1055 §22.355	Frequency Stability Temperature & Voltage	< 2.5 ppm for Part 22H	PASS	-
	§2.1055 §24.235 §27.54		Within Authorized Band		



Report Section	FCC Rule	Description	Limit	Result	Remark
4.4	§2.1053 §22.917(a) §24.238(a) §27.53(c)(2) §27.53(f) §27.53(g) §27.53(h)	Radiated Spurious Emission (Band 2) (Band 4) (Band 5) (Band 12) (Band 13) (Band 17) (Band 25) (Band 26) (Band 66) (Band 71)	$< 43+10\log_{10}(P[\text{Watts}])$	PASS	Under limit 17.47 dB at 7576.000 MHz
	§2.1053 §27.53(m)(4)	Radiated Spurious Emission (Band 7) (Band 38) (Band 41)	$< 55+10\log_{10}(P[\text{Watts}])$		

Declaration of Conformity:

The test results with all measurement uncertainty excluded are presented in accordance with the regulation limits or requirements declared by manufacturers.

Comments and Explanations:

The declared of product specification for EUT presented in the report are provided by the manufacturer, and the manufacturer takes all the responsibilities for the accuracy of product specification.



1 General Description

1.1 Applicant

Motorola Mobility LLC
222 W,Merchandise Mart Plaza, Chicago IL 60654 USA

1.2 Manufacturer

Motorola Mobility LLC
222 W,Merchandise Mart Plaza, Chicago IL 60654 USA

1.3 Product Feature of Equipment Under Test

Product Feature	
Equipment	Mobile Cellular Phone
Brand Name	Motorola
Model Name	XT2045-3
FCC ID	IHDT56YK1
EUT supports Radios application	CDMA/GSM/WCDMA/LTE WLAN 2.4GHz 802.11b/g/n HT20 WLAN 5GHz 802.11a/n HT20/HT40 WLAN 5GHz 802.11ac VHT20/VHT40/VHT80 Bluetooth BR/EDR/LE FM Receiver and GNSS
IMEI Code	Conducted: N/A Radiation: 359109100024195
HW Version	DVT2
SW Version	QPJ30.85
EUT Stage	Identical Prototype



1.4 Product Specification of Equipment Under Test

Standards-related Product Specification	
Tx Frequency	LTE Band 2 : 1850.7 MHz ~ 1909.3 MHz LTE Band 4 : 1710.7 MHz ~ 1754.3 MHz LTE Band 5 : 824.7 MHz ~ 848.3 MHz LTE Band 7 : 2502.5 MHz ~ 2567.5 MHz LTE Band 12 : 699.7 MHz ~ 715.3 MHz LTE Band 13 : 779.5 MHz ~ 784.5 MHz LTE Band 17 : 706.5 MHz ~ 713.5 MHz LTE Band 25 : 1850.7MHz ~ 1914.3 MHz LTE Band 26 : 824.7MHz ~ 848.3 MHz LTE Band 38 : 2572.5MHz ~ 2617.5MHz LTE Band 41 : 2498.5 MHz ~ 2687.5 MHz LTE Band 66 : 1710.7 MHz ~ 1779.3 MHz LTE Band 71: 665.5 MHz ~ 695.5MHz
Rx Frequency	LTE Band 2 : 1930.7 MHz ~ 1989.3 MHz LTE Band 4 : 2110.7 MHz ~ 2154.3 MHz LTE Band 5 : 869.7 MHz ~ 893.3 MHz LTE Band 7 : 2622.5MHz ~ 2687.5 MHz LTE Band 12 : 729.7 MHz ~ 745.3 MHz LTE Band 13 : 748.5 MHz ~ 753.5 MHz LTE Band 17 : 736.5 MHz ~ 743.5 MHz LTE Band 25 : 1930.7MHz ~ 1994.3 MHz LTE Band 26 : 869.7MHz ~ 893.3MHz LTE Band 38 : 2572.5MHz ~ 2617.5MHz LTE Band 41 : 2498.5 MHz ~ 2687.5 MHz LTE Band 66 : 2110.7 MHz~ 2199.3 MHz LTE Band 71: 619.5 MHz ~ 649.5MHz
Bandwidth	LTE Band 2 : 1.4MHz / 3MHz / 5MHz / 10MHz / 15MHz / 20MHz LTE Band 4 : 1.4MHz / 3MHz / 5MHz / 10MHz / 15MHz / 20MHz LTE Band 5 : 1.4MHz / 3MHz / 5MHz / 10MHz LTE Band 7 : 5MHz / 10MHz / 15MHz / 20MHz LTE Band 12 : 1.4MHz / 3MHz / 5MHz / 10MHz LTE Band 13 : 5MHz / 10MHz LTE Band 17 : 5MHz / 10MHz LTE Band 25 : 1.4MHz / 3MHz / 5MHz / 10MHz / 15MHz / 20MHz LTE Band 26 : 1.4MHz / 3MHz / 5MHz / 10MHz / 15MHz LTE Band 38 : 5MHz / 10MHz / 15MHz / 20MHz LTE Band 41 : 5MHz / 10MHz / 15MHz / 20MHz LTE Band 66 : 1.4MHz / 3MHz / 5MHz / 10MHz / 15MHz / 20MHz LTE Band 71 : 5MHz / 10MHz / 15MHz / 20MHz
Maximum Output Power to Antenna	LTE Band 2 : 22.75 dBm LTE Band 4 : 22.53 dBm LTE Band 5 : 23.18 dBm LTE Band 7 : 22.96 dBm LTE Band 13 : 22.95 dBm LTE Band 12 : 23.18 dBm LTE Band 17 : 23.10 dBm LTE Band 25 : 22.89 dBm LTE Band 26 : 23.18 dBm LTE Band 38 : 22.82 dBm LTE Band 41 : 26.24 dBm; Band 41_CA: 24.35 dBm



	LTE Band 66 : 22.61 dBm LTE Band 71 : 23.50 dBm
Antenna Gain	LTE Band 2 : 0.20 dBi LTE Band 4 : 0.64 dBi LTE Band 5 : -2.8 dBi LTE Band 7 : -1.4 dBi LTE Band 12 : -3.1 dBi LTE Band 13 : -2.2 dBi LTE Band 17 : -3.1 dBi LTE Band 25 : 0.20 dBi LTE Band 26 : -2.8 dBi LTE Band 38 : -1.0 dBi LTE Band 41 : -1.0 dBi LTE Band 66 : 0.64 dBi LTE Band 71 : -2.8 dBi
Type of Modulation	QPSK / 16QAM / 64QAM

1.5 Modification of EUT

No modifications are made to the EUT during all test items.



1.6 Maximum ERP/EIRP Power, Frequency Tolerance, and Emission Designator

LTE Band 2		QPSK			16QAM		
BW (MHz)	Frequency Range (MHz)	Emission Designator (99%OBW)	Frequency Tolerance (ppm)	Maximum EIRP(W)	Emission Designator (99%OBW)	Frequency Tolerance (ppm)	Maximum EIRP(W)
1.4	1850.7 ~ 1909.3	1M10G7D	-	0.1991	1M09W7D	-	0.1698
3	1851.5 ~ 1908.5	2M73G7D	-	0.1986	2M72W7D	-	0.1694
5	1852.5 ~ 1907.5	4M50G7D	-	0.1991	4M50W7D	-	0.1698
10	1855.0 ~ 1905.0	9M09G7D	0.0026	0.2032	9M05W7D	-	0.1734
15	1857.5 ~ 1902.5	13M4G7D	-	0.1991	13M4W7D	-	0.1694
20	1860.0 ~ 1900.0	18M5G7D	-	0.2037	18M4W7D	-	0.1698
LTE Band 2		64QAM					
BW (MHz)	Frequency Range (MHz)	Emission Designator (99%OBW)		Frequency Tolerance (ppm)		Maximum EIRP(W)	
1.4	1850.7 ~ 1909.3	1M09W7D		-		0.1393	
3	1851.5 ~ 1908.5	2M73W7D		-		0.1390	
5	1852.5 ~ 1907.5	4M50W7D		-		0.1393	
10	1855.0 ~ 1905.0	9M07W7D		-		0.1429	
15	1857.5 ~ 1902.5	13M5W7D		-		0.1400	
20	1860.0 ~ 1900.0	18M4W7D		-		0.1406	



LTE Band 25		QPSK			16QAM		
BW (MHz)	Frequency Range (MHz)	Emission Designator (99%OBW)	Frequency Tolerance (ppm)	Maximum EIRP(W)	Emission Designator (99%OBW)	Frequency Tolerance (ppm)	Maximum EIRP(W)
1.4	1850.7 ~ 1914.3	1M10G7D	-	0.1991	1M09W7D	-	0.1698
3	1851.5 ~ 1913.5	2M73G7D	-	0.1986	2M72W7D	-	0.1694
5	1852.5 ~ 1912.5	4M50G7D	-	0.1991	4M50W7D	-	0.1698
10	1855.0 ~ 1910.0	9M09G7D	0.0026	0.2032	9M05W7D	-	0.1734
15	1857.5 ~ 1907.5	13M4G7D	-	0.1991	13M4W7D	-	0.1694
20	1860.0 ~ 1905.0	18M5G7D	-	0.2037	18M4W7D	-	0.1698
LTE Band 25		64QAM					
BW (MHz)	Frequency Range (MHz)	Emission Designator (99%OBW)		Frequency Tolerance (ppm)		Maximum EIRP(W)	
1.4	1850.7 ~ 1914.3	1M09W7D		-		0.1393	
3	1851.5 ~ 1913.5	2M73W7D		-		0.1390	
5	1852.5 ~ 1912.5	4M50W7D		-		0.1393	
10	1855.0 ~ 1910.0	9M07W7D		-		0.1429	
15	1857.5 ~ 1907.5	13M5W7D		-		0.1400	
20	1860.0 ~ 1905.0	18M4W7D		-		0.1406	



LTE Band 4		QPSK			16QAM		
BW (MHz)	Frequency Range (MHz)	Emission Designator (99%OBW)	Frequency Tolerance (ppm)	Maximum EIRP(W)	Emission Designator (99%OBW)	Frequency Tolerance (ppm)	Maximum EIRP(W)
1.4	1710.7 ~ 1754.3	1M09G7D	-	0.2046	1M10W7D	-	0.1714
3	1711.5 ~ 1753.5	2M73G7D	-	0.2075	2M73W7D	-	0.1750
5	1712.5 ~ 1752.5	4M51G7D	-	0.2084	4M50W7D	-	0.1762
10	1715.0 ~ 1750.0	9M05G7D	0.0027	0.2075	9M01W7D	-	0.1742
15	1717.5 ~ 1747.5	13M5G7D	-	0.2056	13M5W7D	-	0.1722
20	1720.0 ~ 1745.0	18M5G7D	-	0.2113	18M5W7D	-	0.1762
LTE Band 4		64QAM					
BW (MHz)	Frequency Range (MHz)	Emission Designator (99%OBW)		Frequency Tolerance (ppm)		Maximum EIRP(W)	
1.4	1710.7 ~ 1754.3	1M10W7D		-		0.1396	
3	1711.5 ~ 1753.5	2M74W7D		-		0.1493	
5	1712.5 ~ 1752.5	4M51W7D		-		0.1493	
10	1715.0 ~ 1750.0	9M07W7D		-		0.1486	
15	1717.5 ~ 1747.5	13M5W7D		-		0.1545	
20	1720.0 ~ 1745.0	18M4W7D		-		0.1570	



LTE Band 66		QPSK			16QAM		
BW (MHz)	Frequency Range (MHz)	Emission Designator (99%OBW)	Frequency Tolerance (ppm)	Maximum EIRP(W)	Emission Designator (99%OBW)	Frequency Tolerance (ppm)	Maximum EIRP(W)
1.4	1710.7 ~ 1779.3	1M09G7D	-	0.2046	1M10W7D	-	0.1714
3	1711.5 ~ 1778.5	2M73G7D	-	0.2075	2M73W7D	-	0.1750
5	1712.5 ~ 1777.5	4M51G7D	-	0.2084	4M50W7D	-	0.1762
10	1715.0 ~ 1775.0	9M05G7D	0.0027	0.2075	9M01W7D	-	0.1742
15	1717.5 ~ 1772.5	13M5G7D	-	0.2056	13M5W7D	-	0.1722
20	1720.0 ~ 1770.0	18M5G7D	-	0.2113	18M5W7D	-	0.1762
LTE Band 66		64QAM					
BW (MHz)	Frequency Range (MHz)	Emission Designator (99%OBW)		Frequency Tolerance (ppm)		Maximum EIRP(W)	
1.4	1710.7 ~ 1779.3	1M10W7D		-		0.1396	
3	1711.5 ~ 1778.5	2M74W7D		-		0.1493	
5	1712.5 ~ 1777.5	4M51W7D		-		0.1493	
10	1715.0 ~ 1775.0	9M07W7D		-		0.1486	
15	1717.5 ~ 1772.5	13M5W7D		-		0.1545	
20	1720.0 ~ 1770.0	18M4W7D		-		0.1570	



LTE Band 5		QPSK			16QAM		
BW (MHz)	Frequency Range (MHz)	Emission Designator (99%OBW)	Frequency Tolerance (ppm)	Maximum ERP(W)	Emission Designator (99%OBW)	Frequency Tolerance (ppm)	Maximum ERP(W)
1.4	824.7 ~ 848.3	1M09G7D	-	0.0658	1M09W7D	-	0.0577
3	825.5 ~ 847.5	2M72G7D	-	0.0652	2M74W7D	-	0.0571
5	826.5 ~ 846.5	4M51G7D	-	0.0653	4M49W7D	-	0.0547
10	829.0 ~ 844.0	9M17G7D	0.0026	0.0649	9M05W7D	-	0.0558
LTE Band 5		64QAM					
BW (MHz)	Frequency Range (MHz)	Emission Designator (99%OBW)		Frequency Tolerance (ppm)		Maximum ERP(W)	
1.4	824.7 ~ 848.3	1M09W7D		-		0.0437	
3	825.5 ~ 847.5	2M72W7D		-		0.0435	
5	826.5 ~ 846.5	4M50W7D		-		0.0448	
10	829.0 ~ 844.0	9M01W7D		-		0.0453	
LTE Band 26		QPSK			16QAM		
BW (MHz)	Frequency Range (MHz)	Emission Designator (99%OBW)	Frequency Tolerance (ppm)	Maximum ERP(W)	Emission Designator (99%OBW)	Frequency Tolerance (ppm)	Maximum ERP(W)
1.4	824.7 ~ 848.3	1M09G7D	-	0.0658	1M09W7D	-	0.0577
3	825.5 ~ 847.5	2M72G7D	-	0.0652	2M74W7D	-	0.0571
5	826.5 ~ 846.5	4M51G7D	-	0.0653	4M49W7D	-	0.0547
10	829.0 ~ 844.0	9M17G7D	0.0026	0.0649	9M05W7D	-	0.0558
15	831.5 ~ 841.5	13M5G7D	-	0.0665	13M5W7D	-	0.0581
CH26765	821.5	13M4G7D	-	0.0664	13M4W7D	-	0.0566
LTE Band 26		64QAM					
BW (MHz)	Frequency Range (MHz)	Emission Designator (99%OBW)		Frequency Tolerance (ppm)		Maximum ERP(W)	
1.4	824.7 ~ 848.3	1M09W7D		-		0.0437	
3	825.5 ~ 847.5	2M72W7D		-		0.0435	
5	826.5 ~ 846.5	4M50W7D		-		0.0448	
10	829.0 ~ 844.0	9M01W7D		-		0.0453	
15	831.5 ~ 841.5	13M4W7D		-		0.0478	
CH26765	821.5	13M5W7D		-		0.0471	



LTE Band 7		QPSK			16QAM		
BW (MHz)	Frequency Range (MHz)	Emission Designator (99%OBW)	Frequency Tolerance (ppm)	Maximum EIRP(W)	Emission Designator (99%OBW)	Frequency Tolerance (ppm)	Maximum EIRP(W)
5	2502.5 ~ 2567.5	4M51G7D	-	0.1393	4M50W7D	-	0.1205
10	2505.0 ~ 2565.0	9M13G7D	0.0018	0.1419	9M05W7D	-	0.1219
15	2507.5 ~ 2562.5	13M4G7D	-	0.1429	13M5W7D	-	0.1230
20	2510.0 ~ 2560.0	18M4G7D	-	0.1432	18M4W7D	-	0.1222
LTE Band 7		64QAM					
BW (MHz)	Frequency Range (MHz)	Emission Designator (99%OBW)	Frequency Tolerance (ppm)		Maximum EIRP(W)		
5	2502.5 ~ 2567.5	4M52W7D	-		0.0993		
10	2505.0 ~ 2565.0	9M05W7D	-		0.1007		
15	2507.5 ~ 2562.5	13M5W7D	-		0.1016		
20	2510.0 ~ 2560.0	18M3W7D	-		0.1000		
LTE Band 12		QPSK			16QAM		
BW (MHz)	Frequency Range (MHz)	Emission Designator (99%OBW)	Frequency Tolerance (ppm)	Maximum ERP(W)	Emission Designator (99%OBW)	Frequency Tolerance (ppm)	Maximum ERP(W)
1.4	699.7 ~ 715.3	1M10G7D	-	0.0603	1M09W7D	-	0.0537
3	700.5 ~ 714.5	2M72G7D	-	0.0618	2M73W7D	-	0.0541
5	701.5 ~ 713.5	4M51G7D	-	0.0617	4M49W7D	-	0.0540
10	704.0 ~ 711.0	9M05G7D	0.0026	0.0621	9M13W7D	-	0.0547
LTE Band 12		64QAM					
BW (MHz)	Frequency Range (MHz)	Emission Designator (99%OBW)	Frequency Tolerance (ppm)		Maximum ERP(W)		
1.4	699.7 ~ 715.3	1M10W7D	-		0.0442		
3	700.5 ~ 714.5	2M73W7D	-		0.0443		
5	701.5 ~ 713.5	4M51W7D	-		0.0441		
10	704.0 ~ 711.0	9M09W7D	-		0.0447		



LTE Band 17		QPSK			16QAM		
BW (MHz)	Frequency Range (MHz)	Emission Designator (99%OBW)	Frequency Tolerance (ppm)	Maximum ERP(W)	Emission Designator (99%OBW)	Frequency Tolerance (ppm)	Maximum ERP(W)
5	706.5 ~ 713.5	4M51G7D	-	0.0617	4M49W7D	-	0.0540
10	709.0 ~ 711.0	9M05G7D	0.0026	0.0621	9M13W7D	-	0.0547
LTE Band 17		64QAM					
BW (MHz)	Frequency Range (MHz)	Emission Designator (99%OBW)	Frequency Tolerance (ppm)		Maximum ERP(W)		
5	706.5 ~ 713.5	4M51W7D	-		0.0441		
10	709.0 ~ 711.0	9M09W7D	-		0.0447		

LTE Band 13		QPSK			16QAM		
BW (MHz)	Frequency Range (MHz)	Emission Designator (99%OBW)	Frequency Tolerance (ppm)	Maximum ERP(W)	Emission Designator (99%OBW)	Frequency Tolerance (ppm)	Maximum ERP(W)
5	779.5 ~ 784.5	4M50G7D	-	0.0723	4M52W7D	-	0.0618
10	782.0	8M99G7D	0.0027	0.0724	9M03W7D	-	0.0593
LTE Band 13		64QAM					
BW (MHz)	Frequency Range (MHz)	Emission Designator (99%OBW)	Frequency Tolerance (ppm)		Maximum ERP(W)		
5	779.5 ~ 784.5	4M51W7D	-		0.0509		
10	782.0	9M07W7D	-		0.0494		



LTE Band 38		QPSK			16QAM		
BW (MHz)	Frequency Range (MHz)	Emission Designator (99%OBW)	Frequency Tolerance (ppm)	Maximum EIRP(W)	Emission Designator (99%OBW)	Frequency Tolerance (ppm)	Maximum EIRP(W)
5	2572.5 ~ 2617.5	4M52G7D	-	0.3148	4M51W7D	-	0.2698
10	2575.0 ~ 2615.0	9M05G7D	0.0017	0.3184	9M03W7D	-	0.2748
15	2577.5 ~ 2612.5	13M5G7D	-	0.3266	13M4W7D	-	0.2761
20	2580.0 ~ 2610.0	18M3G7D	-	0.3296	18M5W7D	-	0.2780
LTE Band 38		64QAM					
BW (MHz)	Frequency Range (MHz)	Emission Designator (99%OBW)	Frequency Tolerance (ppm)		Maximum EIRP(W)		
5	2572.5 ~ 2617.5	4M51W7D	-		0.2080		
10	2575.0 ~ 2615.0	9M05W7D	-		0.2143		
15	2577.5 ~ 2612.5	13M5W7D	-		0.2188		
20	2580.0 ~ 2610.0	18M5W7D	-		0.2158		
LTE Band 41		QPSK			16QAM		
BW (MHz)	Frequency Range (MHz)	Emission Designator (99%OBW)	Frequency Tolerance (ppm)	Maximum EIRP(W)	Emission Designator (99%OBW)	Frequency Tolerance (ppm)	Maximum EIRP(W)
5	2498.5 ~ 2687.5	4M52G7D	-	0.3148	4M51W7D	-	0.2698
10	2501.0 ~ 2685.0	9M05G7D	0.0017	0.3184	9M03W7D	-	0.2748
15	2503.5 ~ 2682.5	13M5G7D	-	0.3266	13M4W7D	-	0.2761
20	2506.0 ~ 2680.0	18M3G7D	-	0.3296	18M5W7D	-	0.2780
LTE Band 41		64QAM					
BW (MHz)	Frequency Range (MHz)	Emission Designator (99%OBW)	Frequency Tolerance (ppm)		Maximum EIRP(W)		
5	2498.5 ~ 2687.5	4M51W7D	-		0.2080		
10	2501.0 ~ 2685.0	9M05W7D	-		0.2143		
15	2503.5 ~ 2682.5	13M5W7D	-		0.2188		
20	2506.0 ~ 2680.0	18M5W7D	-		0.2158		



LTE Band 71		QPSK			16QAM		
BW (MHz)	Frequency Range (MHz)	Emission Designator (99%OBW)	Frequency Tolerance (ppm)	Maximum ERP(W)	Emission Designator (99%OBW)	Frequency Tolerance (ppm)	Maximum ERP(W)
5	665.5 ~ 695.5	4M51G7D	-	0.0705	4M52W7D	-	0.0607
10	668.0 ~ 693.0	9M07G7D	0.0024	0.0710	9M05W7D	-	0.0612
15	670.5 ~ 690.5	13M4G7D	-	0.0705	13M5W7D	-	0.0607
20	673.0 ~ 688.0	17M9G7D	-	0.0716	17M9W7D	-	0.0605

LTE Band 71		64QAM		
BW (MHz)	Frequency Range (MHz)	Emission Designator (99%OBW)	Frequency Tolerance (ppm)	Maximum ERP(W)
5	665.5 ~ 695.5	4M50W7D	-	0.0500
10	668.0 ~ 693.0	9M05W7D	-	0.0492
15	670.5 ~ 690.5	13M4W7D	-	0.0499
20	673.0 ~ 688.0	17M9W7D	-	0.0500

LTE Band 41 CA		QPSK			16QAM		
BW (MHz)	Emission Designator (99%OBW)	Frequency Tolerance (ppm)	Maximum EIRP(W)	Emission Designator (99%OBW)	Frequency Tolerance (ppm)	Maximum EIRP(W)	
20MHz+20MHz	37M8G7D	-	0.2163	37M7W7D	-	0.1923	

LTE Band 41 CA		64QAM		
BW (MHz)	Emission Designator (99%OBW)	Frequency Tolerance (ppm)	Maximum EIRP(W)	
20MHz+20MHz	37M6W7D	-	0.1799	

Note:

1. LTE Band 26 overlaps the entire frequency range of LTE Band 5. Therefore, the test results provided in this report covers Band 26 as well as Band 5.
2. LTE Band 66 overlaps the entire frequency range of LTE Band 4. Therefore, the test results provided in this report covers Band 66 as well as Band 4.
3. LTE Band 25 overlaps the entire frequency range of LTE Band 2. Therefore, the test results provided in this report covers Band 25 as well as Band 2.
4. LTE Band 12 overlaps the entire frequency range of LTE Band 17. Therefore, the test results provided in this report covers Band 12 as well as Band 17.



- LTE Band 41 overlaps the entire frequency range of LTE Band 38. Therefore, the test results provided in this report covers Band 41 as well as Band 38.

1.7 Specification of Accessory

Specification of Accessory				
AC Adapter 1	Brand Name	Motorola (Acbel)	Model Name	SC-41
	Power Rating	I/P: 100-240 Vac, 300mA ,50/60HZ O/P: 5Vdc, 2000mA		
AC Adapter 2	Brand Name	Motorola (Chenyang)	Model Name	SC-41
	Power Rating	I/P: 100-240 Vac, 300mA ,50/60HZ O/P: 5Vdc, 2000mA		
Battery	Brand Name	Motorola (ATL)	Model Name	KG40
	Power Rating	3.8Vdc, 3760/4000mAh	Type	Li-ion, Polymer
USB Cable 1	Brand Name	Motorola (LiQi)	Model Name	L52B-053000100
	Signal Line Type	1.0 meter, shielded cable, without ferrite core		
USB Cable 2	Brand Name	Motorola (SaiBao)	Model Name	S52B-053000100
	Signal Line Type	1.0 meter, shielded cable, without ferrite core		

1.8 Testing Location

Sporton International (Kunshan) Inc. is accredited to ISO/IEC 17025:2017 by American Association for Laboratory Accreditation with Certificate Number 5145.02.

Test Firm	Sporton International (Kunshan) Inc.		
Test Site Location	No. 1098, Pengxi North Road, Kunshan Economic Development Zone Jiangsu Province 215300 People's Republic of China TEL : +86-512-57900158 FAX : +86-512-57900958		
Test Site No.	Sporton Site No.	FCC Designation No.	FCC Test Firm Registration No.
	03CH06-KS TH01-KS	CN1257	314309

1.9 Test Software

Item	Site	Manufacture	Name	Version
1.	03CH06-KS	AUDIX	E3	6.2009-8-24al



1.10 Applicable Standards

According to the specifications of the manufacturer, the EUT must comply with the requirements of the following standards:

- ♦ 47 CFR Part 2, 22(H), 24(E), 27(L), 27(M), 27(N), 27(H), 27(F)
- ♦ ANSI C63.26-2015
- ♦ FCC KDB 971168 D01 Power Meas License Digital Systems v03r01
- ♦ FCC KDB 412172 D01 Determining ERP and EIRP v01r01

Remark:

1. All test items were verified and recorded according to the standards and without any deviation during the test.
2. This EUT has also been tested and complied with the requirements of FCC Part 15, Subpart B, recorded in a separate test report.



2 Test Configuration of Equipment Under Test

2.1 Test Mode

Antenna port conducted and radiated test items listed below are performed according to KDB 971168 D01 Power Meas License Digital Systems v03r01 with maximum output power.

Radiated measurements are performed by rotating the EUT in three different orthogonal test planes to find the maximum emission.

Test Items	Band	Bandwidth (MHz)						Modulation			RB #			Test Channel		
		1.4	3	5	10	15	20	QPSK	16QAM	64QAM	1	Half	Full	L	M	H
Max. Output Power	2	v	v	v	v	v	v	v	v	v	v	v	v	v	v	v
	4	v	v	v	v	v	v	v	v	v	v	v	v	v	v	v
	5	v	v	v	v	-	-	v	v	v	v	v	v	v	v	v
	7	-	-	v	v	v	v	v	v	v	v	v	v	v	v	v
	12	v	v	v	v	-	-	v	v	v	v	v	v	v	v	v
	13	-	-	v		-	-	v	v	v	v	v	v	v	v	v
		-	-		v	-	-	v	v	v	v	v	v		v	
	17	-	-	v	v	-	-	v	v	v	v	v	v	v	v	v
	25	v	v	v	v	v	v	v	v	v	v	v	v	v	v	v
	26	v	v	v	v	v	-	v	v	v	v	v	v	v	v	v
	38	-	-	v	v	v	v	v	v	v	v	v	v	v	v	v
	41	-	-	v	v	v	v	v	v	v	v	v	v	v	v	v
66	v	v	v	v	v	v	v	v	v	v	v	v	v	v	v	
71	-	-	v	v	v	v	v	v	v	v	v	v	v	v	v	
Peak-to-Average Ratio	7	-	-				v	v	v	v	v		v	v	v	v
	12				v	-	-	v	v	v	v		v	v	v	v
	13	-	-		v	-	-	v	v	v	v		v		v	
	25						v	v	v	v	v		v	v	v	v
	26				v		-	v	v	v	v		v	v	v	v
	41	-	-				v	v	v	v	v		v	v	v	v
	66						v	v	v	v	v		v	v	v	v
	71	-	-				v	v	v	v	v		v	v	v	v



Test Items	Band	Bandwidth (MHz)						Modulation			RB #			Test Channel		
		1.4	3	5	10	15	20	QPSK	16QAM	64QAM	1	Half	Full	L	M	H
26dB and 99% Bandwidth	7	-	-	v	v	v	v	v	v	v			v	v	v	v
	12	v	v	v	v	-	-	v	v	v			v	v	v	v
	13	-	-	v		-	-	v	v	v			v	v	v	v
		-	-		v	-	-	v	v	v			v		v	
	25	v	v	v	v	v	v	v	v	v			v	v	v	v
	26	v	v	v	v	v	-	v	v	v			v	v	v	v
	41	-	-	v	v	v	v	v	v	v			v	v	v	v
	66	v	v	v	v	v	v	v	v	v			v	v	v	v
71	-	-	v	v	v	v	v	v	v			v	v	v	v	
Conducted Band Edge	7	-	-	v	v	v	v	v	v	v	v		v	v		v
	12	v	v	v	v	-	-	v	v	v	v		v	v		v
	13	-	-	v		-	-	v	v	v	v		v	v		v
		-	-		v	-	-	v	v	v	v		v		v	
	25	v	v	v	v	v	v	v	v	v	v		v	v		v
	26	v	v	v	v	v	-	v	v	v	v		v	v		v
	41	-	-	v	v	v	v	v	v	v	v		v	v		v
	66	v	v	v	v	v	v	v	v	v	v		v	v		v
71	-	-	v	v	v	v	v	v	v	v		v	v		v	



Test Items	Band	Bandwidth (MHz)						Modulation			RB #			Test Channel		
		1.4	3	5	10	15	20	QPSK	16QAM	64QAM	1	Half	Full	L	M	H
Conducted Spurious Emission	7	-	-	v	v	v	v	v	v	v	v			v	v	v
	12	v	v	v	v	-	-	v	v	v	v			v	v	v
	13	-	-	v		-	-	v	v	v	v			v	v	v
		-	-		v	-	-	v	v	v	v				v	
	25	v	v	v	v	v	v	v	v	v	v			v	v	v
	26	v	v	v	v	v	-	v	v	v	v			v	v	v
	41	-	-	v	v	v	v	v	v	v	v			v	v	v
	66	v	v	v	v	v	v	v	v	v	v			v	v	v
71	-	-	v	v	v	v	v	v	v	v			v	v	v	
Frequency Stability	7	-	-		v			v					v		v	
	12				v	-	-	v					v		v	
	13	-	-		v	-	-	v					v		v	
	25				v			v					v		v	
	26				v		-	v					v		v	
	41	-	-		v			v					v		v	
	66				v			v					v		v	
	71	-	-		v			v					v		v	



Test Items	Band	Bandwidth (MHz)						Modulation			RB #			Test Channel		
		1.4	3	5	10	15	20	QPSK	16QAM	64QAM	1	Half	Full	L	M	H
E.R.P / E.I.R.P	7	-	-	v	v	v	v	v	v	v	v			v	v	v
	12	v	v	v	v	-	-	v	v	v	v			v	v	v
	13	-	-	v		-	-	v	v	v	v			v	v	v
		-	-		v	-	-	v	v	v	v				v	
	25	v	v	v	v	v	v	v	v	v	v			v	v	v
	26	v	v	v	v	v	-	v	v	v	v			v	v	v
	41	-	-	v	v	v	v	v	v	v	v			v	v	v
	66	v	v	v	v	v	v	v	v	v	v			v	v	v
71	-	-	v	v	v	v	v	v	v	v			v	v	v	
Radiated Spurious Emission	7	Worst Case												v	v	v
	12	Worst Case												v	v	v
	13	Worst Case												v	v	v
	25	Worst Case												v	v	v
	26	Worst Case												v	v	v
	41	Worst Case												v	v	v
	66	Worst Case												v	v	v
	71	Worst Case												v	v	v
Note	<ol style="list-style-type: none"> The mark "v" means that this configuration is chosen for testing The mark "-" means that this bandwidth is not supported. The device is investigated from 30MHz to 10 times of fundamental signal for radiated spurious emission test under different RB size/offset and modulations in exploratory test. Subsequently, only the worst case emissions are reported. LTE Band 26 overlaps the entire frequency range of LTE Band 5. Therefore, the test results provided in this report covers Band 26 as well as Band 5. LTE Band 66 overlaps the entire frequency range of LTE Band 4. Therefore, the test results provided in this report covers Band 66 as well as Band 4. LTE Band 25 overlaps the entire frequency range of LTE Band 2. Therefore, the test results provided in this report covers Band 25 as well as Band 2. LTE Band 12 overlaps the entire frequency range of LTE Band 17. Therefore, the test results provided in this report covers Band 12 as well as Band 17. LTE Band 41 overlaps the entire frequency range of LTE Band 38. Therefore, the test results provided in this report covers Band 41 as well as Band 38. 															



Test Items	Band	Bandwidth (MHz)										Modulation			RB #			Test Channel				
		20+20	20+15	15+20	20+10	10+20	20+5	5+20	15+15	15+10	10+15	QPSK	16QAM	64QAM	1	Half	Full	L	M	H		
Max. Output Power	41C_CA	v										v	v	v	v	v	v	v	v	v		
26dB and 99% Bandwidth	41C_CA	v	v	v	v	v	v	v	v	v	v	v	v	v			v	v	v	v		
Conducted Band Edge	41C_CA	v	v	v	v	v	v	v	v	v	v	v	v	v		v	v			v		
Conducted Spurious Emission	41C_CA	v	v	v	v	v	v	v	v	v	v	v	v	v						v		
E.I.R.P.	41C_CA	v											v	v	v					v		
Radiated Spurious Emission	41C_CA	Worst case																		v	v	v
Note	1. The mark "v " means that this configuration is chosen for testing 2. The mark "-" means that this bandwidth is not supported. 3. The device is investigated from 30MHz to 10 times of fundamental signal for radiated spurious emission test under different RB size/offset and modulations in exploratory test. Subsequently, only the worst case emissions are reported.																					

2.2 Connection Diagram of Test System

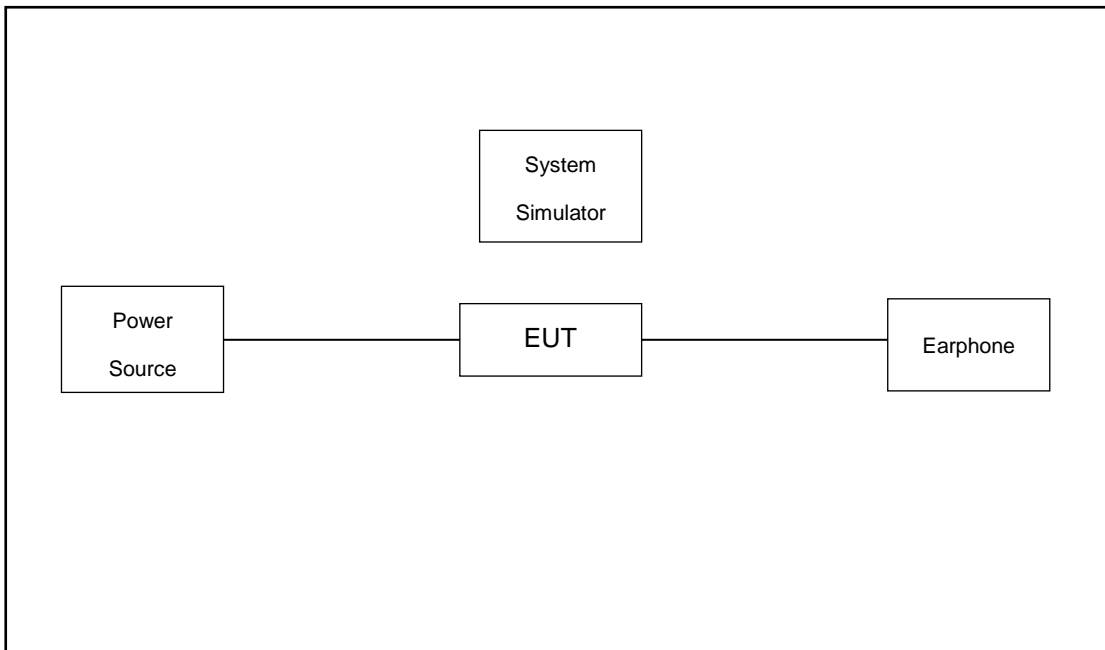

2.3 Support Unit used in test configuration and system

Item	Equipment	Trade Name	Model No.	FCC ID	Data Cable	Power Cord
1.	Power Supply	GWINSTEK	PSS-2002	N/A	N/A	Unshielded, 1.8m
2.	LTE Base Station	Anritsu	MT8820C	N/A	N/A	Unshielded, 1.8m
3.	Earphone	Moto	SH38C16618	N/A	Unshielded, 1.2m	N/A

2.4 Measurement Results Explanation Example

For all conducted test items:

The offset level is set in the spectrum analyzer to compensate the RF cable loss between EUT conducted output port and spectrum analyzer. With the offset compensation, the spectrum analyzer reading level is exactly the EUT RF output level.

The spectrum analyzer offset is derived from RF cable loss.

Offset = RF cable loss.

Following shows an offset computation example with cable loss 9.40 dB.

Example :

$$\begin{aligned}
 \text{Offset(dB)} &= \text{RF cable loss(dB)}. \\
 &= 9.40 \text{ (dB)}
 \end{aligned}$$



2.5 Frequency List of Low/Middle/High Channels

LTE Band 2 Channel and Frequency List				
BW [MHz]	Channel/Frequency(MHz)	Lowest	Middle	Highest
20	Channel	18700	18900	19100
	Frequency	1860	1880	1900
15	Channel	18675	18900	19125
	Frequency	1857.5	1880	1902.5
10	Channel	18650	18900	19150
	Frequency	1855	1880	1905
5	Channel	18625	18900	19175
	Frequency	1852.5	1880	1907.5
3	Channel	18615	18900	19185
	Frequency	1851.5	1880	1908.5
1.4	Channel	18607	18900	19193
	Frequency	1850.7	1880	1909.3

LTE Band 4 Channel and Frequency List				
BW [MHz]	Channel/Frequency(MHz)	Lowest	Middle	Highest
20	Channel	20050	20175	20300
	Frequency	1720	1732.5	1745
15	Channel	20025	20175	20325
	Frequency	1717.5	1732.5	1747.5
10	Channel	20000	20175	20350
	Frequency	1715	1732.5	1750
5	Channel	19975	20175	20375
	Frequency	1712.5	1732.5	1752.5
3	Channel	19965	20175	20385
	Frequency	1711.5	1732.5	1753.5
1.4	Channel	19957	20175	20393
	Frequency	1710.7	1732.5	1754.3



LTE Band 5 Channel and Frequency List				
BW [MHz]	Channel/Frequency(MHz)	Lowest	Middle	Highest
10	Channel	20450	20525	20600
	Frequency	829	836.5	844
5	Channel	20425	20525	20625
	Frequency	826.5	836.5	846.5
3	Channel	20415	20525	20635
	Frequency	825.5	836.5	847.5
1.4	Channel	20407	20525	20643
	Frequency	824.7	836.5	848.3

LTE Band 7 Channel and Frequency List				
BW [MHz]	Channel/Frequency(MHz)	Lowest	Middle	Highest
20	Channel	20850	21100	21350
	Frequency	2510	2535	2560
15	Channel	20825	21100	21375
	Frequency	2507.5	2535	2562.5
10	Channel	20800	21100	21400
	Frequency	2505	2535	2565
5	Channel	20775	21100	21425
	Frequency	2502.5	2535	2567.5



LTE Band 12 Channel and Frequency List				
BW [MHz]	Channel/Frequency(MHz)	Lowest	Middle	Highest
10	Channel	23060	23095	23130
	Frequency	704	707.5	711
5	Channel	23035	23095	23155
	Frequency	701.5	707.5	713.5
3	Channel	23025	23095	23165
	Frequency	700.5	707.5	714.5
1.4	Channel	23017	23095	23173
	Frequency	699.7	707.5	715.3

LTE Band 13 Channel and Frequency List				
BW [MHz]	Channel/Frequency(MHz)	Lowest	Middle	Highest
10	Channel	-	23230	-
	Frequency	-	782	-
5	Channel	23205	23230	23255
	Frequency	779.5	782	784.5

LTE Band 17 Channel and Frequency List				
BW [MHz]	Channel/Frequency(MHz)	Lowest	Middle	Highest
10	Channel	23780	23790	23800
	Frequency	709	710	711
5	Channel	23755	23790	23825
	Frequency	706.5	710	713.5



LTE Band 25 Channel and Frequency List				
BW [MHz]	Channel/Frequency(MHz)	Lowest	Middle	Highest
20	Channel	26140	26340	26590
	Frequency	1860	1880	1905
15	Channel	26115	26340	26615
	Frequency	1857.5	1880	1907.5
10	Channel	26090	26340	26640
	Frequency	1855	1880	1910
5	Channel	26065	26340	26665
	Frequency	1852.5	1880	1912.5
3	Channel	26055	26340	26675
	Frequency	1851.5	1880	1913.5
1.4	Channel	26047	26340	26683
	Frequency	1850.7	1880	1914.3

LTE Band 26 Channel and Frequency List				
BW [MHz]	Channel/Frequency(MHz)	Lowest	Middle	Highest
15	Channel	26865	26915	26965
	Frequency	831.5	836.5	841.5
10	Channel	26840	26915	26990
	Frequency	829	836.5	844
5	Channel	26815	26915	27015
	Frequency	826.5	836.5	846.5
3	Channel	26805	26915	27025
	Frequency	825.5	836.5	847.5
1.4	Channel	26797	26915	27033
	Frequency	824.7	836.5	848.3



LTE Band 38 Channel and Frequency List				
BW [MHz]	Channel/Frequency(MHz)	Lowest	Middle	Highest
20	Channel	37850	38000	38150
	Frequency	2580	2595	2610
15	Channel	37825	38000	38175
	Frequency	2577.5	2595	2612.5
10	Channel	37800	38000	38200
	Frequency	2575	2595	2615
5	Channel	37775	38000	38225
	Frequency	2572.5	2595	2617.5

LTE Band 41 Channel and Frequency List				
BW [MHz]	Channel/Frequency(MHz)	Lowest	Middle	Highest
20	Channel	39750	40620	41490
	Frequency	2506	2593	2680
15	Channel	39725	40620	41515
	Frequency	2503.5	2593	2682.5
10	Channel	39700	40620	41540
	Frequency	2501	2593	2685
5	Channel	39675	40620	41565
	Frequency	2498.5	2593	2687.5



LTE Band 66 Channel and Frequency List				
BW [MHz]	Channel/Frequency(MHz)	Lowest	Middle	Highest
20	Channel	132072	132322	132572
	Frequency	1720	1745	1770
15	Channel	132047	132322	132597
	Frequency	1717.5	1745	1772.5
10	Channel	132022	132322	132622
	Frequency	1715	1745	1775
5	Channel	131997	132322	132647
	Frequency	1712.5	1745	1777.5
3	Channel	131987	132322	132657
	Frequency	1711.5	1745	1778.5
1.4	Channel	131979	132322	132665
	Frequency	1710.7	1745	1779.3

LTE Band 71 Channel and Frequency List				
BW [MHz]	Channel/Frequency(MHz)	Lowest	Middle	Highest
20	Channel	133222	133322	133372
	Frequency	673.0	680.5	688.0
15	Channel	133197	133297	133397
	Frequency	670.5	680.5	690.5
10	Channel	133172	133272	133422
	Frequency	668.0	678.0	693.0
5	Channel	133147	133247	133447
	Frequency	665.5	675.5	695.5



LTE Band 41C_CA Channel and Frequency List					
BW [MHz]	Channel/Frequency(MHz)		Lowest	Middle	Highest
20 + 20	PCC	Channel	39750	40521	41292
		Frequency	2506.0	2583.1	2660.2
	SCC	Channel	39948	40719	41490
		Frequency	2525.8	2602.9	2680.0
20 + 15	PCC	Channel	39750	40546	41341
		Frequency	2506.0	2585.6	2665.1
	SCC	Channel	39921	40717	41512
		Frequency	2523.1	2602.7	2682.2
15 + 20	PCC	Channel	39728	40523	41319
		Frequency	2503.8	2593.3	2662.9
	SCC	Channel	39899	40694	41490
		Frequency	2520.9	2600.4	2680.0
20 + 10	PCC	Channel	39750	40571	41391
		Frequency	2506.0	2588.1	2670.1
	SCC	Channel	39894	40715	41535
		Frequency	2520.4	2602.5	2684.5
10 + 20	PCC	Channel	39705	40526	41346
		Frequency	2501.5	2583.6	2665.6
	SCC	Channel	39849	40670	41490
		Frequency	2515.9	2598.0	2680.0



LTE Band 41C_CA Channel and Frequency List					
20 + 5	PCC	Channel	39750	40595	41440
		Frequency	2506.0	2590.5	2675.0
	SCC	Channel	39867	40712	41557
		Frequency	2517.7	2602.2	2686.7
5 + 20	PCC	Channel	39683	40528	41373
		Frequency	2499.3	2583.8	2668.3
	SCC	Channel	39800	40645	41490
		Frequency	2511.0	2595.5	2680.0
15 + 15	PCC	Channel	39725	40545	41365
		Frequency	2503.5	2585.5	2667.5
	SCC	Channel	39875	40695	41515
		Frequency	2518.5	2600.5	2682.5
10 + 15	PCC	Channel	39703	40549	41395
		Frequency	2501.3	2585.9	2670.5
	SCC	Channel	39823	40669	41515
		Frequency	2513.3	2597.9	2682.5
15 + 10	PCC	Channel	39725	40571	41417
		Frequency	2503.5	2588.1	2672.7
	SCC	Channel	39845	40691	41537
		Frequency	2515.5	2600.1	2684.7

3 Conducted Test Items

3.1 Measuring Instruments

See list of measuring instruments of this test report.

3.2 Test Setup

3.2.1 Conducted Output Power

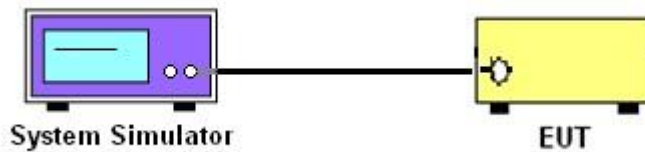

3.2.2 Peak-to-Average Ratio, Occupied Bandwidth ,Conducted Band-Edge and Conducted Spurious Emission

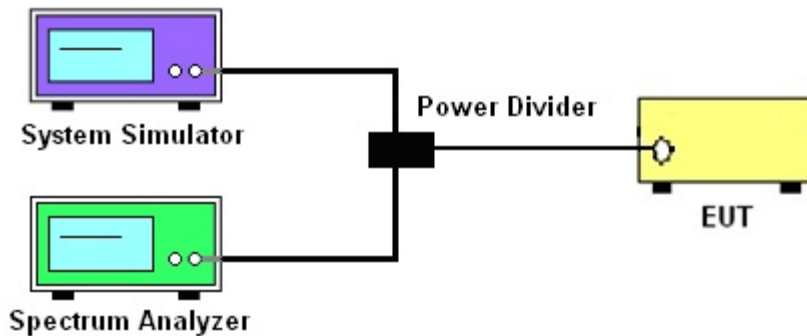

3.2.3 Frequency Stability

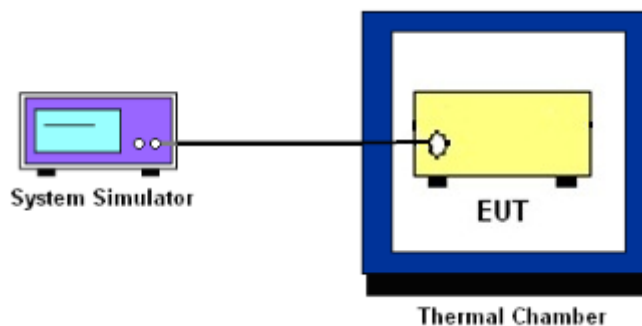

3.3 Test Result of Conducted Test

Please refer to Appendix A.



3.4 Conducted Output Power and ERP/EIRP

3.4.1 Description of the Conducted Output Power Measurement and ERP/EIRP Measurement

A system simulator was used to establish communication with the EUT. Its parameters were set to force the EUT transmitting at maximum output power. The measured power in the radio frequency on the transmitter output terminals shall be reported.

The ERP of mobile transmitters must not exceed 7 Watts for LTE Band 5 and Band 26.

The ERP of mobile transmitters must not exceed 3 Watts for LTE Band 12, Band 13 and Band 17 and Band 71.

The EIRP of mobile transmitters must not exceed 2 Watts for LTE Band 2 and Band 25 and Band 7 and Band 38 and Band 41.

The EIRP of mobile transmitters must not exceed 1 Watts for LTE Band 4 and Band 66.

According to KDB 412172 D01 Power Approach,

$EIRP = P_T + G_T - L_C$, $ERP = EIRP - 2.15$, where

P_T = transmitter output power in dBm

G_T = gain of the transmitting antenna in dBi

L_C = signal attenuation in the connecting cable between the transmitter and antenna in dB

3.4.2 Test Procedures

1. The testing follows ANSI C63.26 Section 5.2
2. The transmitter output port was connected to the system simulator.
3. Set EUT at maximum power through the system simulator.
4. Select lowest, middle, and highest channels for each band and different modulation.
5. Measure and record the power level from the system simulator.



3.5 Peak-to-Average Ratio

3.5.1 Description of the PAR Measurement

Power Complementary Cumulative Distribution Function (CCDF) curves provide a means for characterizing the power peaks of a digitally modulated signal on a statistical basis. A CCDF curve depicts the probability of the peak signal amplitude exceeding the average power level. Most contemporary measurement instrumentation include the capability to produce CCDF curves for an input signal provided that the instrument's resolution bandwidth can be set wide enough to accommodate the entire input signal bandwidth. In measuring transmissions in this band using an average power technique, the peak-to-average ratio (PAR) of the transmission may not exceed 13 dB.

3.5.2 Test Procedures

1. The testing follows ANSI C63.26 Section 5.2.3.4 (CCDF).
2. The EUT was connected to spectrum and system simulator via a power divider.
3. Set the CCDF (Complementary Cumulative Distribution Function) option in spectrum analyzer.
4. The highest RF powers were measured and recorded the maximum PAPR level associated with a probability of 0.1 %.
5. Record the deviation as Peak to Average Ratio.



3.6 Occupied Bandwidth

3.6.1 Description of Occupied Bandwidth Measurement

The occupied bandwidth is the width of a frequency band such that, below the lower and above the upper frequency limits, the mean powers emitted are each equal to a specified percentage 0.5% of the total mean transmitted power.

The 26 dB emission bandwidth is defined as the frequency range between two points, one above and one below the carrier frequency, at which the spectral density of the emission is attenuated 26 dB below the maximum in-band spectral density of the modulated signal. Spectral density (power per unit bandwidth) is to be measured with a detector of resolution bandwidth equal to approximately 1.0% of the emission bandwidth.

3.6.2 Test Procedures

1. The testing follows ANSI C63.26 Section 5.4
2. The EUT was connected to spectrum analyzer and system simulator via a power divider.
3. The spectrum analyzer center frequency is set to the nominal EUT channel center frequency. The span range for the spectrum analyzer shall be between two and five times the anticipated OBW.
4. The nominal resolution bandwidth (RBW) shall be in the range of 1 to 5 % of the anticipated OBW, and the VBW shall be at least 3 times the RBW.
5. Set the detection mode to peak, and the trace mode to max hold.
6. Determine the reference value: Set the EUT to transmit a modulated signal. Allow the trace to stabilize. Set the spectrum analyzer marker to the highest level of the displayed trace.
(this is the reference value)
7. Determine the “-26 dB down amplitude” as equal to (Reference Value – X).
8. Place two markers, one at the lowest and the other at the highest frequency of the envelope of the spectral display such that each marker is at or slightly below the “-X dB down amplitude” determined in step 6. If a marker is below this “-X dB down amplitude” value it shall be placed as close as possible to this value. The OBW is the positive frequency difference between the two markers.
9. Use the 99 % power bandwidth function of the spectrum analyzer and report the measured bandwidth.



3.7 Conducted Band Edge

3.7.1 Description of Conducted Band Edge Measurement

22.917(a)

For operations in the 824 – 849 MHz band, the FCC limit is $43 + 10\log_{10}(P[\text{Watts}])$ dB below the transmitter power P(Watts) in a 100kHz bandwidth. However, in the 1MHz bands immediately outside and adjacent to the licensee's frequency block, a resolution bandwidth of at least one percent of the emission bandwidth of the fundamental emission of the transmitter may be employed.

24.238 (a)

For operations in the 1850-1910 and 1930-1990 MHz band, the FCC limit is $43 + 10\log_{10}(P[\text{Watts}])$ dB below the transmitter power P(Watts) in a 1MHz bandwidth. However, in the 1 MHz bands immediately outside and adjacent to the frequency block a resolution bandwidth of at least one percent of the emission bandwidth of the fundamental emission of the transmitter may be employed.

27.53 (c)

For operations in the 776-788 MHz band, the FCC limit is $43 + 10\log_{10}(P[\text{Watts}])$ dB below the transmitter power P(Watts) in a 100 kHz bandwidth. However, in the 100 kHz bands immediately outside and adjacent to the frequency block, a resolution bandwidth of at least 30 kHz may be employed. In addition, the power of any unwanted emissions in any 6.25 kHz bandwidth for all frequencies between 763-775 MHz and 793-806 MHz shall be attenuated below the transmitter power, P (dBW), by at least $65 + 10 \log_{10} p(\text{watts})$, dB, for mobile and portable equipment.

27.53 (g)

For operations in the 600MHz band and 698 -746 MHz band, the FCC limit is $43 + 10\log_{10}(P[\text{Watts}])$ dB below the transmitter power P(Watts) in a 100 kHz bandwidth. However, in the 100 kilohertz bands immediately outside and adjacent to a licensee's frequency block, a resolution bandwidth of at least 30 kHz may be employed.

27.53 (h)

For operations in the 1710 – 1755 MHz band, the FCC limit is $43 + 10\log_{10}(P[\text{Watts}])$ dB below the transmitter power P(Watts) in a 1 MHz bandwidth. However, in the 1MHz bands immediately outside and adjacent to the licensee's frequency block, a resolution bandwidth of at least one percent of the emission bandwidth of the fundamental emission of the transmitter may be employed.



27.53(m)(4)

For mobile digital stations, the attenuation factor shall be not less than $40 + 10 \log (P)$ dB on all frequencies between the channel edge and 5 megahertz from the channel edge, $43 + 10 \log (P)$ dB on all frequencies between 5 megahertz and X megahertz from the channel edge, and $55 + 10 \log (P)$ dB on all frequencies more than X megahertz from the channel edge, where X is the greater of 6 megahertz or the actual emission bandwidth as defined in paragraph (m)(6) of this section. In addition, the attenuation factor shall not be less that $43 + 10 \log (P)$ dB on all frequencies between 2490.5 MHz and 2496 MHz and $55 + 10 \log (P)$ dB at or below 2490.5 MHz. Mobile Satellite Service licensees operating on frequencies below 2495 MHz may also submit a documented interference complaint against BRS licensees operating on channel BRS Channel 1 on the same terms and conditions as adjacent channel BRS or EBS licensees.

3.7.2 Test Procedures

1. The testing follows ANSI C63.26 section 5.7
2. The EUT was connected to spectrum analyzer and system simulator via a power divider.
3. The band edges of low and high channels for the highest RF powers were measured.
4. Set RBW $\geq 1\%$ EBW in the 1MHz band immediately outside and adjacent to the band edge.
5. Beyond the 1 MHz band from the band edge, RBW=1MHz was used or a narrower RBW was used and the measured power was integrated over the full required measurement bandwidth of 1 MHz.
6. Set spectrum analyzer with RMS detector.
7. Offset has included the duty factor for LTE Band 38/41. Duty factor = $10 \log (1/x)$, where x is the measured duty cycle
8. The RF fundamental frequency should be excluded against the limit line in the operating frequency band.
9. Checked that all the results comply with the emission limit line.

Example:

$$\begin{aligned} & \text{The limit line is derived from } 43 + 10\log(P)\text{dB below the transmitter power } P(\text{Watts}) \\ & = P(\text{W}) - [43 + 10\log(P)] \text{ (dB)} \\ & = [30 + 10\log(P)] \text{ (dBm)} - [43 + 10\log(P)] \text{ (dB)} = -13\text{dBm}. \end{aligned}$$

10. For LTE Band 7, 38, 41, the other 40 dB, and 55 dB have additionally applied same calculation above.



3.8 Conducted Spurious Emission

3.8.1 Description of Conducted Spurious Emission Measurement

The power of any emission outside of the authorized operating frequency ranges must be lower than the transmitter power (P) by a factor of at least $43 + 10 \log (P)$ dB.

For Band 7,38,41:

The power of any emission outside of the authorized operating frequency ranges must be lower than the transmitter power (P) by a factor of at least $55 + 10 \log (P)$ dB.

It is measured by means of a calibrated spectrum analyzer and scanned from 30 MHz up to a frequency including its 10th harmonic.

3.8.2 Test Procedures

1. The testing follows ANSI C63.26 section 5.7
2. The EUT was connected to spectrum analyzer and system simulator via a power divider.
3. The RF output of EUT was connected to the spectrum analyzer by RF cable and attenuator. The path loss was compensated to the results for each measurement.
4. The middle channel for the highest RF power within the transmitting frequency was measured.
5. The conducted spurious emission for the whole frequency range was taken.
6. Make the measurement with the spectrum analyzer's RBW = 1MHz, VBW = 3MHz.
7. Set spectrum analyzer with RMS detector.
8. Offset has included the duty factor for LTE Band 38/41. Duty factor = $10 \log (1/x)$, where x is the measured duty cycle
9. Taking the record of maximum spurious emission.
10. The RF fundamental frequency should be excluded against the limit line in the operating frequency band.
11. The limit line is derived from $43 + 10 \log (P)$ dB below the transmitter power P(Watts)
= $P(W) - [43 + 10 \log (P)]$ (dB)
= $[30 + 10 \log (P)]$ (dBm) - $[43 + 10 \log (P)]$ (dB)
= -13dBm.
12. For Band 7, 38, 41
The limit line is derived from $55 + 10 \log (P)$ dB below the transmitter power P(Watts)
= $P(W) - [55 + 10 \log (P)]$ (dB)
= $[30 + 10 \log (P)]$ (dBm) - $[55 + 10 \log (P)]$ (dB)
= -25dBm.



3.9 Frequency Stability

3.9.1 Description of Frequency Stability Measurement

The frequency stability shall be measured by variation of ambient temperature and variation of primary supply voltage to ensure that the fundamental emission stays within the authorized frequency block. The frequency stability of the transmitter shall be maintained within $\pm 0.00025\%$ ($\pm 2.5\text{ppm}$) of the center frequency.

3.9.2 Test Procedures for Temperature Variation

1. The testing follows ANSI C63.26 section 5.6.4
2. The EUT was set up in the thermal chamber and connected with the system simulator.
3. With power OFF, the temperature was decreased to -30°C and the EUT was stabilized before testing. Power was applied and the maximum change in frequency was recorded within one minute.
4. With power OFF, the temperature was raised in 10°C step up to 50°C . The EUT was stabilized at each step for at least half an hour. Power was applied and the maximum frequency change was recorded within one minute.

3.9.3 Test Procedures for Voltage Variation

1. The testing follows ANSI C63.26 section 5.6.5
2. The EUT was placed in a temperature chamber at $20\pm 5^{\circ}\text{C}$ and connected with the system simulator.
3. The power supply voltage to the EUT was varied from 85% to 115% of the nominal value for other than hand carried battery equipment.
4. For hand carried, battery powered equipment, reduce the primary ac or dc supply voltage to the battery operating end point, which shall be specified by the manufacturer.
5. The variation in frequency was measured for the worst case.

4 Radiated Test Items

4.1 Measuring Instruments

See list of measuring instruments of this test report.

4.2 Test Setup

4.2.1 For radiated test from 30MHz to 1GHz

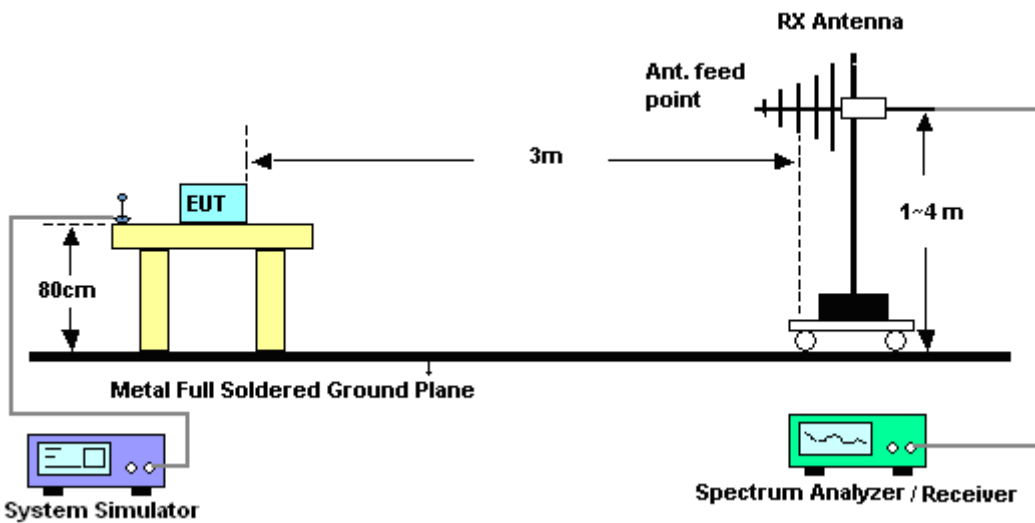

4.2.2 For radiated test above 1GHz

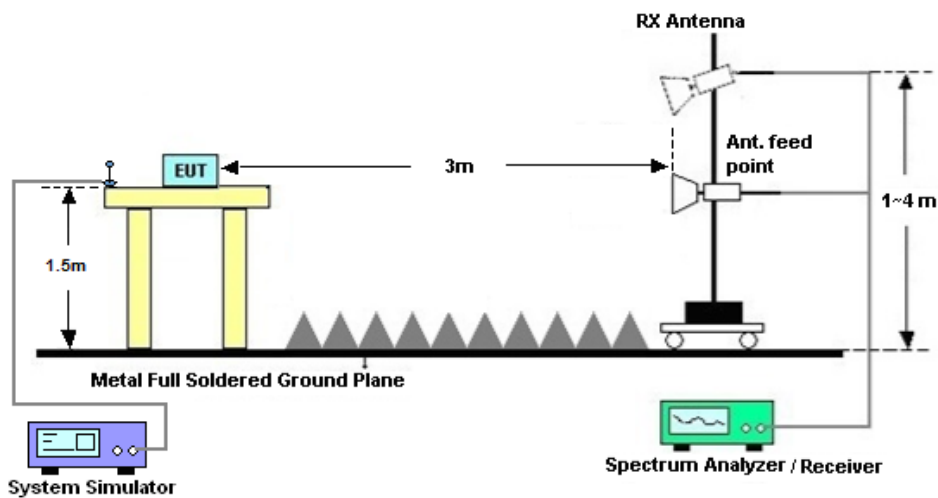

4.3 Test Result of Radiated Test

Please refer to Appendix B.



4.4 Radiated Spurious Emission

4.4.1 Description of Radiated Spurious Emission

The radiated spurious emission was measured by substitution method according to ANSI C63.26. The power of any emission outside of the authorized operating frequency ranges must be attenuated below the transmitter power (P) by a factor of at least $43 + 10 \log (P)$ dB.

For Band 7, 38, 41

The power of any emission outside of the authorized operating frequency ranges must be attenuated below the transmitter power (P) by a factor of at least $55 + 10 \log (P)$ dB.

For LTE Band 13

For operations in the 746-758 MHz, 775-788 MHz, and 805-806 MHz bands, emissions in the band 1559-1610 MHz shall be limited to -70 dBW/MHz equivalent isotropically radiated power (EIRP) for wideband signals, and -80 dBW EIRP for discrete emissions of less than 700 Hz bandwidth.

The spectrum is scanned from 30 MHz up to a frequency including its 10th harmonic.

4.4.2 Test Procedures

1. The testing follows ANSI C63.26 Section 5.5
2. The EUT was placed on a turntable with 0.8 meter height for frequency below 1GHz and 1.5 meter height for frequency above 1GHz respectively above ground.
3. The EUT was set 3 meters from the receiving antenna mounted on the antenna tower.
4. The table was rotated 360 degrees to determine the position of the highest spurious emission.
5. The height of the receiving antenna is varied between 1m to 4m to search the maximum spurious emission for both horizontal and vertical polarizations.
6. During the measurement, the system simulator parameters were set to force the EUT transmitting at maximum output power.
7. Make the measurement with the spectrum analyzer's RBW = 1MHz, VBW = 3MHz, taking the record of maximum spurious emission.
8. A horn antenna was substituted in place of the EUT and was driven by a signal generator.
9. Tune the output power of signal generator to the same emission level with EUT maximum spurious emission.
10. $EIRP (dBm) = S.G. Power - Tx Cable Loss + Tx Antenna Gain$
11. $ERP (dBm) = EIRP - 2.15$
12. The RF fundamental frequency should be excluded against the limit line in the operating frequency band.
The limit line is derived from $43 + 10\log(P)$ dB below the transmitter power P(Watts)
 $= P(W) - [43 + 10\log(P)] (dB)$
 $= [30 + 10\log(P)] (dBm) - [43 + 10\log(P)] (dB)$
 $= -13dBm.$
13. For Band 7, 38, 41:
The limit line is derived from $55 + 10\log(P)$ dB below the transmitter power P(Watts)



5 List of Measuring Equipment

Instrument	Manufacturer	Model No.	Serial No.	Characteristics	Calibration Date	Test Date	Due Date	Remark
Spectrum Analyzer	R&S	FSV30	101338	10Hz~30GHz	Apr. 16, 2019	Jan. 23, 2020~ Mar. 03, 2020	Apr. 15, 2020	Conducted (TH01-KS)
Temperature & humidity chamber	Hongzhan	LP-150U	H2014011440	-40~+150°C 20%~95%RH	Jul. 04, 2019	Jan. 23, 2020~ Mar. 03, 2020	Jul. 03, 2020	Conducted (TH01-KS)
EXA Spectrum Analyzer	Keysight	N9010A	MY55150208	10Hz-44GHz	Apr. 16, 2019	Mar. 09, 2020	Apr. 15, 2020	Radiation (03CH06-KS)
Bilog Antenna	TeseQ	CBL6111D	49921	30MHz-1GHz	May 30, 2019	Mar. 09, 2020	May 29, 2020	Radiation (03CH06-KS)
Double Ridge Horn Antenna	ETS-Lindgren	3117	00218652	1GHz~18GHz	Apr. 27, 2019	Mar. 09, 2020	Apr. 26, 2020	Radiation (03CH06-KS)
SHF-EHF Horn	Com-power	AH-840	101115	18GHz~40GHz	Nov. 10, 2019	Mar. 09, 2020	Nov. 09, 2020	Radiation (03CH06-KS)
Amplifier	SONOMA	310N	187289	9KHz ~1GHZ	Aug. 06, 2019	Mar. 09, 2020	Aug. 05, 2020	Radiation (03CH06-KS)
Amplifier	MITEQ	EM18G40G GA	060728	18~40GHz	Jan. 08, 2020	Mar. 09, 2020	Jan. 07, 2021	Radiation (03CH06-KS)
high gain Amplifier	MITEQ	AMF-7D-00 101800-30-1 0P	2025788	1Ghz-18Ghz	Apr. 17, 2019	Mar. 09, 2020	Apr. 16, 2020	Radiation (03CH06-KS)
Amplifier	Keysight	83017A	MY53270203	500MHz~26.5GHz	Apr. 15, 2019	Mar. 09, 2020	Apr. 14, 2020	Radiation (03CH06-KS)
AC Power Source	Chroma	61601	F104090004	N/A	NCR	Mar. 09, 2020	NCR	Radiation (03CH06-KS)
Turn Table	ChamPro	EM 1000-T	060762-T	0~360 degree	NCR	Mar. 09, 2020	NCR	Radiation (03CH06-KS)
Antenna Mast	ChamPro	EM 1000-A	060762-A	1 m~4 m	NCR	Mar. 09, 2020	NCR	Radiation (03CH06-KS)

NCR: No Calibration Required



6 Uncertainty of Evaluation

The measurement uncertainties shown below were calculated in accordance with the requirements of ANSI 63.26-2015. All the measurement uncertainty value were shown with a coverage K=2 to indicate 95% level of confidence. The measurement data show herein meets or exceeds the CISPR measurement uncertainty values specified in CISPR 16-4-2 and can be compared directly to specified limit to determine compliance.

Uncertainty of Radiated Emission Measurement (30 MHz ~ 1000 MHz)

Measuring Uncertainty for a Level of Confidence of 95% (U = 2Uc(y))	2.5dB
---------------------------------------------------------------------	-------

Uncertainty of Radiated Emission Measurement (1 GHz ~ 40 GHz)

Measuring Uncertainty for a Level of Confidence of 95% (U = 2Uc(y))	2.1dB
---------------------------------------------------------------------	-------



Appendix A. Test Results of Conducted Test

Conducted Output Power(Average power)

LTE Band 2 Maximum Average Power [dBm]						
BW [MHz]	RB Size	RB Offset	Mod	Lowest	Middle	Highest
20	1	0	QPSK	22.68	22.75	22.46
20	1	49		22.61	22.53	22.45
20	1	99		22.40	22.37	22.36
20	50	0		21.70	21.71	21.54
20	50	24		21.69	21.57	21.54
20	50	50		21.52	21.51	21.46
20	100	0		21.57	21.58	21.48
20	1	0	16-QAM	21.96	21.86	21.76
20	1	49		21.90	21.88	21.77
20	1	99		21.70	21.72	21.74
20	50	0		20.78	20.70	20.58
20	50	24		20.80	20.70	20.57
20	50	50		20.61	20.62	20.58
20	100	0		20.63	20.61	20.59
20	1	0	64-QAM	21.30	21.22	21.11
20	1	49		21.24	21.20	21.11
20	1	99		21.04	21.07	21.10
20	50	0		20.23	20.10	20.00
20	50	24		20.20	20.10	19.99
20	50	50		20.00	20.04	20.01
20	100	0		20.06	20.06	20.04
15	1	0	QPSK	22.74	22.61	22.49
15	1	37		22.65	22.52	22.44
15	1	74		22.56	22.44	22.40
15	36	0		21.71	21.58	21.53
15	36	20		21.71	21.59	21.53
15	36	39		21.65	21.55	21.52
15	75	0		21.69	21.61	21.52
15	1	0	16-QAM	22.01	21.95	21.85



15	1	37		21.95	21.89	21.82
15	1	74		21.85	21.81	21.79
15	36	0		20.75	20.70	20.61
15	36	20		20.82	20.73	20.64
15	36	39		20.70	20.60	20.58
15	75	0		20.73	20.66	20.60
15	1	0	64-QAM	21.11	21.03	20.93
15	1	37		21.05	21.01	20.91
15	1	74		20.97	20.94	20.91
15	36	0		20.00	19.92	19.84
15	36	20		20.03	19.95	19.86
15	36	39		19.90	19.81	19.79
15	75	0		19.95	19.88	19.80



LTE Band 2 Maximum Average Power [dBm]						
BW [MHz]	RB Size	RB Offset	Mod	Lowest	Middle	Highest
10	1	0	QPSK	22.71	22.58	22.52
10	1	25		22.67	22.54	22.49
10	1	49		22.63	22.52	22.42
10	25	0		21.74	21.64	21.51
10	25	12		21.74	21.64	21.56
10	25	25		21.71	21.57	21.48
10	50	0		21.72	21.61	21.53
10	1	0	16-QAM	22.00	21.95	21.84
10	1	25		22.02	21.92	21.88
10	1	49		21.93	21.90	21.84
10	25	0		20.83	20.70	20.66
10	25	12		20.84	20.70	20.64
10	25	25		20.78	20.64	20.61
10	50	0		20.78	20.68	20.61
10	1	0	64-QAM	21.15	21.08	20.98
10	1	25		21.17	21.05	21.01
10	1	49		21.07	21.01	20.97
10	25	0		20.08	19.95	19.91
10	25	12		20.08	19.96	19.88
10	25	25		20.03	19.88	19.85
10	50	0		20.02	19.92	19.84
5	1	0	QPSK	22.72	22.61	22.49
5	1	12		22.70	22.57	22.50
5	1	24		22.71	22.56	22.47
5	12	0		21.75	21.64	21.53
5	12	7		21.74	21.63	21.59
5	12	13		21.72	21.60	21.55
5	25	0		21.73	21.61	21.50
5	1	0	16-QAM	22.03	21.98	21.91
5	1	12		21.99	21.96	21.91
5	1	24		21.99	21.94	21.88
5	12	0		20.80	20.70	20.65
5	12	7		20.79	20.73	20.69



5	12	13		20.80	20.66	20.69
5	25	0		20.80	20.68	20.63
5	1	0	64-QAM	21.17	21.08	21.04
5	1	12		21.17	21.08	21.01
5	1	24		21.11	21.07	20.99
5	12	0		20.03	19.94	19.90
5	12	7		20.03	19.98	19.93
5	12	13		20.04	19.90	19.88
5	25	0		20.05	19.94	19.87



LTE Band 2 Maximum Average Power [dBm]						
BW [MHz]	RB Size	RB Offset	Mod	Lowest	Middle	Highest
3	1	0	QPSK	22.73	22.60	22.54
3	1	8		22.73	22.60	22.51
3	1	14		22.72	22.57	22.49
3	8	0		21.78	21.64	21.56
3	8	4		21.80	21.68	21.58
3	8	7		21.73	21.61	21.55
3	15	0		21.77	21.62	21.59
3	1	0	16-QAM	22.03	21.97	21.89
3	1	8		22.06	21.99	21.93
3	1	14		22.01	21.92	21.84
3	8	0		20.83	20.77	20.72
3	8	4		20.90	20.79	20.75
3	8	7		20.86	20.77	20.73
3	15	0		20.85	20.76	20.68
3	1	0	64-QAM	21.18	21.14	21.00
3	1	8		21.18	21.13	21.04
3	1	14		21.16	21.08	20.99
3	8	0		20.08	19.98	19.95
3	8	4		20.09	20.00	19.98
3	8	7		20.05	19.97	19.94
3	15	0		20.08	19.97	19.92
1.4	1	0	QPSK	22.72	22.60	22.56
1.4	1	3		22.72	22.60	22.56
1.4	1	5		22.71	22.57	22.53
1.4	3	0		22.65	22.52	22.48
1.4	3	1		22.67	22.56	22.52
1.4	3	3		22.60	22.49	22.45
1.4	6	0		21.76	21.62	21.58
1.4	1	0	16-QAM	22.02	21.97	21.93
1.4	1	3		22.05	21.99	21.95
1.4	1	5		22.00	21.92	21.88
1.4	3	0		21.70	21.65	21.61
1.4	3	1		21.77	21.67	21.63



1.4	3	3	64-QAM	21.73	21.65	21.61
1.4	6	0		20.84	20.76	20.72
1.4	1	0		21.17	21.14	21.10
1.4	1	3		21.17	21.13	21.09
1.4	1	5		21.15	21.08	21.04
1.4	3	0		20.95	20.86	20.82
1.4	3	1		20.96	20.88	20.84
1.4	3	3		20.92	20.85	20.81
1.4	6	0		20.07	19.97	19.93



LTE Band 4 Maximum Average Power [dBm]						
BW [MHz]	RB Size	RB Offset	Mod	Lowest	Middle	Highest
20	1	0	QPSK	22.49	22.53	22.30
20	1	49		22.35	22.26	22.31
20	1	99		22.22	22.23	22.22
20	50	0		21.45	21.46	21.38
20	50	24		21.43	21.35	21.34
20	50	50		21.29	21.30	21.30
20	100	0		21.40	21.41	21.35
20	1	0	16-QAM	21.83	21.69	21.69
20	1	49		21.73	21.60	21.71
20	1	99		21.54	21.62	21.57
20	50	0		20.49	20.39	20.43
20	50	24		20.49	20.44	20.45
20	50	50		20.39	20.37	20.42
20	100	0		20.46	20.36	20.42
20	1	0	64-QAM	20.99	20.80	20.81
20	1	49		20.88	20.76	20.85
20	1	99		20.69	20.73	20.70
20	50	0		19.75	19.63	19.67
20	50	24		19.74	19.68	19.69
20	50	50		19.60	19.62	19.65
20	100	0		19.70	19.62	19.68
15	1	0	QPSK	22.48	22.39	22.34
15	1	37		22.46	22.28	22.30
15	1	74		22.31	22.26	22.25
15	36	0		21.53	21.30	21.35
15	36	20		21.42	21.35	21.37
15	36	39		21.42	21.34	21.34
15	75	0		21.40	21.34	21.36
15	1	0	16-QAM	21.85	21.64	21.72
15	1	37		21.85	21.62	21.65
15	1	74		21.62	21.64	21.55
15	36	0		20.57	20.39	20.47
15	36	20		20.50	20.45	20.45



15	36	39	64-QAM	20.48	20.41	20.38
15	75	0		20.48	20.37	20.43
15	1	0		20.98	20.83	20.88
15	1	37		20.97	20.74	20.82
15	1	74		20.80	20.78	20.70
15	36	0		19.82	19.61	19.72
15	36	20		19.72	19.68	19.70
15	36	39		19.72	19.66	19.62
15	75	0		19.74	19.64	19.68



LTE Band 4 Maximum Average Power [dBm]						
BW [MHz]	RB Size	RB Offset	Mod	Lowest	Middle	Highest
10	1	0	QPSK	22.51	22.41	22.31
10	1	25		22.50	22.30	22.32
10	1	49		22.34	22.25	22.26
10	25	0		21.53	21.34	21.37
10	25	12		21.56	21.37	21.39
10	25	25		21.38	21.29	21.29
10	50	0		21.40	21.30	21.33
10	1	0	16-QAM	21.85	21.65	21.69
10	1	25		21.83	21.60	21.65
10	1	49		21.62	21.61	21.54
10	25	0		20.62	20.37	20.41
10	25	12		20.60	20.42	20.45
10	25	25		20.44	20.40	20.41
10	50	0		20.48	20.37	20.44
10	1	0	64-QAM	20.96	20.83	20.84
10	1	25		20.97	20.78	20.78
10	1	49		20.80	20.74	20.72
10	25	0		19.88	19.63	19.67
10	25	12		19.86	19.68	19.70
10	25	25		19.70	19.64	19.63
10	50	0		19.71	19.63	19.68
5	1	0	QPSK	22.46	22.29	22.29
5	1	12		22.48	22.29	22.32
5	1	24		22.43	22.21	22.27
5	12	0		21.49	21.34	21.34
5	12	7		21.56	21.32	21.36
5	12	13		21.47	21.30	21.32
5	25	0		21.51	21.32	21.35
5	1	0	16-QAM	21.79	21.55	21.60
5	1	12		21.83	21.57	21.65
5	1	24		21.79	21.58	21.54
5	12	0		20.61	20.39	20.41
5	12	7		20.60	20.38	20.45



5	12	13	64-QAM	20.59	20.36	20.39
5	25	0		20.56	20.37	20.43
5	1	0		20.94	20.67	20.77
5	1	12		20.96	20.77	20.72
5	1	24		20.91	20.70	20.67
5	12	0		19.85	19.62	19.64
5	12	7		19.83	19.64	19.67
5	12	13		19.83	19.61	19.62
5	25	0		19.80	19.64	19.68



LTE Band 4 Maximum Average Power [dBm]						
BW [MHz]	RB Size	RB Offset	Mod	Lowest	Middle	Highest
3	1	0	QPSK	22.50	22.33	22.47
3	1	8		22.49	22.22	22.46
3	1	14		22.33	22.17	22.30
3	8	0		21.52	21.26	21.49
3	8	4		21.55	21.29	21.52
3	8	7		21.37	21.21	21.34
3	15	0		21.39	21.22	21.36
3	1	0	16-QAM	21.84	21.57	21.81
3	1	8		21.82	21.52	21.79
3	1	14		21.61	21.53	21.58
3	8	0		20.61	20.29	20.58
3	8	4		20.59	20.34	20.56
3	8	7		20.43	20.32	20.40
3	15	0		20.47	20.29	20.44
3	1	0	64-QAM	20.95	20.75	20.92
3	1	8		20.96	20.70	20.93
3	1	14		20.79	20.66	20.76
3	8	0		19.87	19.55	19.84
3	8	4		19.85	19.60	19.82
3	8	7		19.69	19.56	19.66
3	15	0		19.70	19.55	19.67
1.4	1	0	QPSK	22.25	22.21	22.42
1.4	1	3		22.25	22.21	22.44
1.4	1	5		22.17	22.13	22.39
1.4	3	0		22.18	22.14	22.33
1.4	3	1		22.16	22.12	22.40
1.4	3	3		22.14	22.10	22.31
1.4	6	0		21.28	21.24	21.47
1.4	1	0	16-QAM	21.51	21.47	21.75
1.4	1	3		21.53	21.49	21.79
1.4	1	5		21.54	21.50	21.75
1.4	3	0		21.23	21.19	21.45
1.4	3	1		21.22	21.18	21.44



1.4	3	3	64-QAM	21.20	21.16	21.43
1.4	6	0		20.33	20.29	20.52
1.4	1	0		20.63	20.59	20.90
1.4	1	3		20.73	20.69	20.92
1.4	1	5		20.66	20.62	20.87
1.4	3	0		20.46	20.42	20.69
1.4	3	1		20.48	20.44	20.67
1.4	3	3		20.45	20.41	20.67
1.4	6	0		19.60	19.56	19.76



LTE Band 5 Maximum Average Power [dBm]						
BW [MHz]	RB Size	RB Offset	Mod	Lowest	Middle	Highest
10	1	0	QPSK	23.10	23.18	23.07
10	1	25		23.14	23.12	22.93
10	1	49		23.14	23.03	22.86
10	25	0		22.21	22.27	22.10
10	25	12		22.26	22.20	22.09
10	25	25		22.20	22.12	21.94
10	50	0		22.27	22.28	22.09
10	1	0	16-QAM	22.51	22.57	22.42
10	1	25		22.50	22.51	22.20
10	1	49		22.54	22.33	22.15
10	25	0		21.28	21.30	21.16
10	25	12		21.38	21.27	21.15
10	25	25		21.34	21.22	21.00
10	50	0		21.35	21.29	21.13
10	1	0	64-QAM	21.69	21.69	21.54
10	1	25		21.64	21.68	21.39
10	1	49		21.71	21.51	21.32
10	25	0		20.58	20.55	20.43
10	25	12		20.62	20.55	20.43
10	25	25		20.58	20.50	20.26
10	50	0		20.59	20.52	20.39
5	1	0	QPSK	23.14	23.12	22.88
5	1	12		23.14	23.10	22.87
5	1	24		23.10	23.04	22.80
5	12	0		22.21	22.16	21.94
5	12	7		22.22	22.18	21.92
5	12	13		22.15	22.15	21.91
5	25	0		22.18	22.11	21.93
5	1	0	16-QAM	22.41	22.48	22.10
5	1	12		22.42	22.42	22.11
5	1	24		22.39	22.35	22.04
5	12	0		21.25	21.29	20.99
5	12	7		21.29	21.28	21.01



5	12	13	64-QAM	21.25	21.20	20.96
5	25	0		21.24	21.24	20.98
5	1	0		21.63	21.63	21.31
5	1	12		21.61	21.61	21.31
5	1	24		21.56	21.53	21.25
5	12	0		20.52	20.55	20.24
5	12	7		20.56	20.54	20.28
5	12	13		20.48	20.46	20.22
5	25	0		20.53	20.50	20.25



LTE Band 5 Maximum Average Power [dBm]						
BW [MHz]	RB Size	RB Offset	Mod	Lowest	Middle	Highest
3	1	0	QPSK	23.17	22.97	23.06
3	1	8		23.13	22.91	23.02
3	1	14		23.13	22.82	23.02
3	8	0		22.20	21.98	22.09
3	8	4		22.25	21.99	22.14
3	8	7		22.19	21.91	22.08
3	15	0		22.26	21.94	22.15
3	1	0	16-QAM	22.50	22.36	22.39
3	1	8		22.49	22.30	22.38
3	1	14		22.53	22.12	22.42
3	8	0		21.27	21.09	21.16
3	8	4		21.37	21.06	21.26
3	8	7		21.33	21.01	21.22
3	15	0		21.34	21.08	21.23
3	1	0	64-QAM	21.68	21.48	21.57
3	1	8		21.63	21.47	21.52
3	1	14		21.70	21.30	21.59
3	8	0		20.57	20.34	20.46
3	8	4		20.61	20.34	20.50
3	8	7		20.57	20.29	20.46
3	15	0		20.58	20.31	20.47
1.4	1	0	QPSK	22.99	22.90	22.93
1.4	1	3		22.85	22.86	22.79
1.4	1	5		22.78	22.86	22.72
1.4	3	0		22.90	22.81	22.84
1.4	3	1		22.89	22.86	22.83
1.4	3	3		22.74	22.80	22.68
1.4	6	0		22.01	21.99	21.95
1.4	1	0	16-QAM	22.34	22.23	22.28
1.4	1	3		22.12	22.22	22.06
1.4	1	5		22.07	22.26	22.01
1.4	3	0		21.96	21.88	21.90
1.4	3	1		21.95	21.98	21.89



1.4	3	3	64-QAM	21.80	21.94	21.74
1.4	6	0		21.05	21.07	20.99
1.4	1	0		21.46	21.41	21.40
1.4	1	3		21.31	21.36	21.25
1.4	1	5		21.24	21.43	21.18
1.4	3	0		21.23	21.18	21.17
1.4	3	1		21.23	21.22	21.17
1.4	3	3		21.06	21.18	21.00
1.4	6	0		20.31	20.31	20.25



LTE Band 7 Maximum Average Power [dBm]						
BW [MHz]	RB Size	RB Offset	Mod	Lowest	Middle	Highest
20	1	0	QPSK	22.86	22.96	22.62
20	1	49		22.92	22.65	22.75
20	1	99		22.90	22.78	22.78
20	50	0		21.88	22.03	22.00
20	50	24		21.98	21.74	21.69
20	50	50		22.02	21.74	21.81
20	100	0		21.91	21.75	21.68
20	1	0	16-QAM	22.20	22.08	21.99
20	1	49		22.27	22.00	22.10
20	1	99		22.24	22.18	22.12
20	50	0		21.00	20.82	20.79
20	50	24		21.10	20.83	20.81
20	50	50		21.12	20.82	20.92
20	100	0		21.00	20.83	20.81
20	1	0	64-QAM	21.33	21.23	21.18
20	1	49		21.40	21.15	21.29
20	1	99		21.38	21.29	21.31
20	50	0		20.25	20.09	20.05
20	50	24		20.37	20.08	20.06
20	50	50		20.34	20.12	20.17
20	100	0		20.24	20.08	20.09
15	1	0	QPSK	22.87	22.76	22.63
15	1	37		22.93	22.67	22.74
15	1	74		22.95	22.85	22.83
15	36	0		21.89	21.71	21.68
15	36	20		21.91	21.76	21.84
15	36	39		21.98	21.72	21.79
15	75	0		21.91	21.72	21.70
15	1	0	16-QAM	22.25	22.09	22.05
15	1	37		22.29	22.00	22.13
15	1	74		22.30	22.22	22.20
15	36	0		21.02	20.81	20.82
15	36	20		21.01	20.83	20.93
15	36	39		21.09	20.83	20.91



15	75	0		20.99	20.81	20.83
15	1	0	64-QAM	21.41	21.30	21.23
15	1	37		21.43	21.20	21.31
15	1	74		21.47	21.37	21.39
15	36	0		20.30	20.09	20.09
15	36	20		20.27	20.10	20.20
15	36	39		20.35	20.09	20.17
15	75	0		20.26	20.08	20.10



LTE Band 7 Maximum Average Power [dBm]						
BW [MHz]	RB Size	RB Offset	Mod	Lowest	Middle	Highest
10	1	0	QPSK	22.87	22.75	22.70
10	1	25		22.82	22.63	22.71
10	1	49		22.92	22.67	22.72
10	25	0		21.89	21.70	21.71
10	25	12		21.88	21.69	21.73
10	25	25		21.89	21.69	21.73
10	50	0		21.90	21.72	21.76
10	1	0	16-QAM	22.19	22.04	22.07
10	1	25		22.18	21.99	22.10
10	1	49		22.26	22.00	22.16
10	25	0		21.01	20.79	20.83
10	25	12		20.98	20.80	20.87
10	25	25		21.00	20.81	20.86
10	50	0		21.01	20.80	20.87
10	1	0	64-QAM	21.36	21.22	21.25
10	1	25		21.32	21.15	21.23
10	1	49		21.43	21.18	21.30
10	25	0		20.25	20.02	20.08
10	25	12		20.24	20.08	20.12
10	25	25		20.26	20.05	20.11
10	50	0		20.26	20.02	20.12
5	1	0	QPSK	22.83	22.63	22.69
5	1	12		22.84	22.64	22.71
5	1	24		22.84	22.63	22.68
5	12	0		21.89	21.67	21.73
5	12	7		21.93	21.73	21.79
5	12	13		21.90	21.69	21.77
5	25	0		21.88	21.69	21.72
5	1	0	16-QAM	22.19	21.98	22.07
5	1	12		22.21	22.00	22.13
5	1	24		22.21	22.00	22.14
5	12	0		21.00	20.79	20.84
5	12	7		21.03	20.79	20.90



5	12	13	64-QAM	21.02	20.79	20.88
5	25	0		21.01	20.75	20.86
5	1	0		21.37	21.13	21.21
5	1	12		21.36	21.14	21.25
5	1	24		21.37	21.18	21.27
5	12	0		20.24	20.02	20.08
5	12	7		20.30	20.05	20.13
5	12	13		20.26	20.05	20.13
5	25	0		20.27	20.02	20.09



LTE Band 12 Maximum Average Power [dBm]						
BW [MHz]	RB Size	RB Offset	Mod	Lowest	Middle	Highest
10	1	0	QPSK	22.97	23.00	23.13
10	1	25		23.05	23.18	23.12
10	1	49		23.17	23.15	23.15
10	25	0		22.11	22.27	22.15
10	25	12		22.26	22.21	22.18
10	25	25		22.24	22.17	22.15
10	50	0		22.24	22.25	22.14
10	1	0	16-QAM	22.29	22.30	22.49
10	1	25		22.34	22.58	22.57
10	1	49		22.63	22.54	22.55
10	25	0		21.21	21.30	21.28
10	25	12		21.31	21.33	21.29
10	25	25		21.32	21.30	21.25
10	50	0		21.31	21.31	21.26
10	1	0	64-QAM	21.45	21.46	21.66
10	1	25		21.55	21.74	21.70
10	1	49		21.75	21.70	21.70
10	25	0		20.49	20.53	20.55
10	25	12		20.58	20.59	20.56
10	25	25		20.58	20.56	20.50
10	50	0		20.55	20.58	20.52
5	1	0	QPSK	22.95	22.99	23.07
5	1	12		23.07	23.11	23.15
5	1	24		23.02	23.14	23.13
5	12	0		22.14	22.17	22.10
5	12	7		22.19	22.20	22.23
5	12	13		22.12	22.19	22.16
5	25	0		22.12	22.15	22.12
5	1	0	16-QAM	22.26	22.31	22.51
5	1	12		22.36	22.54	22.47
5	1	24		22.32	22.57	22.50
5	12	0		21.20	21.27	21.26
5	12	7		21.22	21.33	21.33



5	12	13	64-QAM	21.22	21.31	21.25
5	25	0		21.20	21.28	21.18
5	1	0		21.44	21.49	21.63
5	1	12		21.51	21.69	21.66
5	1	24		21.46	21.69	21.66
5	12	0		20.44	20.53	20.45
5	12	7		20.47	20.60	20.60
5	12	13		20.43	20.54	20.54
5	25	0		20.48	20.54	20.48



LTE Band 12 Maximum Average Power [dBm]						
BW [MHz]	RB Size	RB Offset	Mod	Lowest	Middle	Highest
3	1	0	QPSK	22.94	22.96	23.14
3	1	8		23.06	23.14	23.13
3	1	14		23.01	23.11	23.16
3	8	0		22.13	22.18	22.16
3	8	4		22.18	22.17	22.19
3	8	7		22.11	22.13	22.16
3	15	0		22.11	22.15	22.15
3	1	0	16-QAM	22.25	22.26	22.50
3	1	8		22.35	22.54	22.58
3	1	14		22.31	22.50	22.56
3	8	0		21.19	21.26	21.29
3	8	4		21.21	21.29	21.30
3	8	7		21.21	21.26	21.26
3	15	0		21.19	21.27	21.27
3	1	0	64-QAM	21.43	21.42	21.67
3	1	8		21.50	21.70	21.71
3	1	14		21.45	21.66	21.71
3	8	0		20.43	20.49	20.56
3	8	4		20.46	20.55	20.57
3	8	7		20.42	20.52	20.51
3	15	0		20.47	20.54	20.53
1.4	1	0	QPSK	22.93	22.94	22.96
1.4	1	3		23.05	23.05	23.02
1.4	1	5		23.00	23.01	23.04
1.4	3	0		22.99	23.00	22.99
1.4	3	1		23.04	22.99	23.04
1.4	3	3		22.97	22.98	23.00
1.4	6	0		22.10	22.11	22.15
1.4	1	0	16-QAM	22.24	22.25	22.26
1.4	1	3		22.34	22.35	22.55
1.4	1	5		22.30	22.31	22.50
1.4	3	0		22.05	22.06	22.13
1.4	3	1		22.07	22.08	22.14



1.4	3	3	64-QAM	22.07	22.08	22.13
1.4	6	0		21.18	21.19	21.27
1.4	1	0		21.42	21.43	21.42
1.4	1	3		21.49	21.50	21.70
1.4	1	5		21.44	21.45	21.66
1.4	3	0		21.29	21.30	21.36
1.4	3	1		21.32	21.33	21.42
1.4	3	3		21.28	21.29	21.39
1.4	6	0		20.46	20.47	20.54



LTE Band 13 Maximum Average Power [dBm]						
BW [MHz]	RB Size	RB Offset	Mod	Lowest	Middle	Highest
10	1	0	QPSK		22.95	
10	1	25			22.77	
10	1	49			22.71	
10	25	0			21.87	
10	25	12			21.83	
10	25	25			21.82	
10	50	0			21.82	
10	1	0	16-QAM	-	22.08	-
10	1	25			22.06	
10	1	49			22.07	
10	25	0			20.98	
10	25	12			20.95	
10	25	25			20.91	
10	50	0			20.94	
10	1	0	64-QAM		21.29	
10	1	25			21.25	
10	1	49			21.21	
10	25	0			20.23	
10	25	12			20.22	
10	25	25			20.17	
10	50	0			20.18	
5	1	0	QPSK	22.94	22.86	22.71
5	1	12		22.89	22.76	22.71
5	1	24		22.78	22.71	22.69
5	12	0		21.98	21.84	21.78
5	12	7		22.02	21.86	21.83
5	12	13		21.87	21.81	21.78
5	25	0		21.88	21.81	21.79
5	1	0	16-QAM	22.09	22.22	22.08
5	1	12		22.26	22.09	22.07
5	1	24		22.13	22.06	22.06
5	12	0		21.09	20.97	20.91
5	12	7		21.15	20.96	20.93



5	12	13	64-QAM	21.02	20.93	20.92
5	25	0		20.96	20.90	20.87
5	1	0		21.30	21.42	21.22
5	1	12		21.38	21.24	21.21
5	1	24		21.25	21.22	21.18
5	12	0		20.34	20.21	20.17
5	12	7		20.40	20.20	20.20
5	12	13		20.28	20.20	20.15
5	25	0		20.23	20.18	20.15



LTE Band 17 Maximum Average Power [dBm]						
BW [MHz]	RB Size	RB Offset	Mod	Lowest	Middle	Highest
10	1	0	QPSK	23.10	23.08	23.06
10	1	25		23.08	23.08	22.98
10	1	49		22.96	22.95	22.97
10	25	0		22.17	22.15	22.15
10	25	12		22.14	22.14	22.14
10	25	25		22.13	22.14	22.02
10	50	0		22.10	22.12	22.11
10	1	0	16-QAM	22.34	22.33	22.36
10	1	25		22.48	22.47	22.33
10	1	49		22.27	22.24	22.24
10	25	0		21.19	21.25	21.20
10	25	12		21.23	21.25	21.25
10	25	25		21.19	21.17	21.07
10	50	0		21.22	21.23	21.22
10	1	0	64-QAM	21.54	21.52	21.57
10	1	25		21.65	21.62	21.53
10	1	49		21.46	21.44	21.45
10	25	0		20.47	20.50	20.50
10	25	12		20.49	20.51	20.51
10	25	25		20.45	20.44	20.33
10	50	0		20.48	20.49	20.48
5	1	0	QPSK	23.00	23.06	22.95
5	1	12		23.01	23.07	22.95
5	1	24		23.02	22.95	22.92
5	12	0		22.17	22.11	21.96
5	12	7		22.20	22.15	22.00
5	12	13		22.18	22.12	21.97
5	25	0		22.18	22.12	21.98
5	1	0	16-QAM	22.32	22.42	22.28
5	1	12		22.39	22.42	22.23
5	1	24		22.45	22.25	22.20
5	12	0		21.22	21.21	21.07
5	12	7		21.31	21.26	21.09



5	12	13	64-QAM	21.25	21.23	21.04
5	25	0		21.23	21.19	21.02
5	1	0		21.54	21.58	21.47
5	1	12		21.61	21.61	21.42
5	1	24		21.61	21.45	21.41
5	12	0		20.48	20.47	20.33
5	12	7		20.51	20.53	20.33
5	12	13		20.48	20.49	20.31
5	25	0		20.48	20.46	20.30



LTE Band 25 Maximum Average Power [dBm]						
BW [MHz]	RB Size	RB Offset	Mod	Lowest	Middle	Highest
20	1	0	QPSK	22.84	22.89	22.46
20	1	49		22.76	22.54	22.60
20	1	99		22.61	22.45	22.48
20	50	0		21.81	21.82	21.52
20	50	24		21.75	21.60	21.64
20	50	50		21.64	21.56	21.58
20	100	0		21.72	21.73	21.50
20	1	0	16-QAM	22.10	22.05	21.78
20	1	49		22.04	21.96	21.97
20	1	99		21.93	21.83	21.86
20	50	0		20.90	20.72	20.61
20	50	24		20.81	20.74	20.75
20	50	50		20.72	20.66	20.69
20	100	0		20.75	20.66	20.63
20	1	0	64-QAM	21.28	21.23	20.93
20	1	49		21.23	21.09	21.13
20	1	99		21.09	21.00	21.05
20	50	0		20.15	19.98	19.88
20	50	24		20.07	19.99	20.01
20	50	50		19.98	19.88	19.92
20	100	0		20.02	19.94	19.91
15	1	0	QPSK	22.79	22.67	22.59
15	1	37		22.77	22.51	22.60
15	1	74		22.57	22.43	22.51
15	36	0		21.84	21.56	21.64
15	36	20		21.85	21.60	21.64
15	36	39		21.65	21.57	21.57
15	75	0		21.71	21.58	21.59
15	1	0	16-QAM	22.07	22.01	21.92
15	1	37		22.09	21.90	21.96
15	1	74		21.89	21.84	21.84
15	36	0		20.89	20.69	20.74
15	36	20		20.92	20.73	20.77



15	36	39	64-QAM	20.72	20.68	20.71
15	75	0		20.76	20.70	20.75
15	1	0		21.26	21.22	21.10
15	1	37		21.24	21.09	21.10
15	1	74		21.04	20.98	21.01
15	36	0		20.14	19.96	20.02
15	36	20		20.18	20.01	20.04
15	36	39		19.99	19.93	19.97
15	75	0		20.03	19.94	20.00



LTE Band 25 Maximum Average Power [dBm]						
BW [MHz]	RB Size	RB Offset	Mod	Lowest	Middle	Highest
10	1	0	QPSK	22.88	22.77	22.57
10	1	25		22.78	22.55	22.57
10	1	49		22.78	22.56	22.50
10	25	0		21.86	21.61	21.61
10	25	12		21.85	21.64	21.60
10	25	25		21.81	21.56	21.53
10	50	0		21.83	21.61	21.60
10	1	0	16-QAM	22.19	22.13	21.97
10	1	25		22.07	21.93	21.96
10	1	49		22.08	21.94	21.84
10	25	0		20.93	20.70	20.71
10	25	12		20.90	20.71	20.72
10	25	25		20.86	20.66	20.66
10	50	0		20.88	20.67	20.70
10	1	0	64-QAM	21.35	21.31	21.14
10	1	25		21.26	21.10	21.14
10	1	49		21.22	21.10	21.04
10	25	0		20.18	19.95	19.97
10	25	12		20.19	19.97	19.98
10	25	25		20.12	19.92	19.92
10	50	0		20.13	19.93	19.95
5	1	0	QPSK	22.79	22.53	22.55
5	1	12		22.77	22.54	22.53
5	1	24		22.74	22.48	22.48
5	12	0		21.80	21.59	21.58
5	12	7		21.84	21.63	21.61
5	12	13		21.78	21.55	21.57
5	25	0		21.80	21.56	21.57
5	1	0	16-QAM	22.10	21.92	21.95
5	1	12		22.10	21.94	21.91
5	1	24		22.02	21.87	21.85
5	12	0		20.89	20.66	20.73
5	12	7		20.88	20.67	20.76



5	12	13		20.82	20.63	20.69
5	25	0		20.88	20.63	20.68
5	1	0	64-QAM	21.23	21.07	21.11
5	1	12		21.24	21.06	21.10
5	1	24		21.16	21.01	21.01
5	12	0		20.14	19.90	19.97
5	12	7		20.14	19.94	19.99
5	12	13		20.09	19.90	19.92
5	25	0		20.15	19.90	19.94



LTE Band 25 Maximum Average Power [dBm]						
BW [MHz]	RB Size	RB Offset	Mod	Lowest	Middle	Highest
3	1	0	QPSK	22.78	22.49	22.56
3	1	8		22.76	22.50	22.54
3	1	14		22.73	22.44	22.49
3	8	0		21.79	21.55	21.59
3	8	4		21.83	21.59	21.62
3	8	7		21.77	21.51	21.58
3	15	0		21.79	21.52	21.58
3	1	0	16-QAM	22.09	21.88	21.96
3	1	8		22.09	21.90	21.92
3	1	14		22.01	21.83	21.86
3	8	0		20.88	20.62	20.74
3	8	4		20.87	20.63	20.77
3	8	7		20.81	20.59	20.70
3	15	0		20.87	20.59	20.69
3	1	0	64-QAM	21.22	21.03	21.12
3	1	8		21.23	21.02	21.11
3	1	14		21.15	20.97	21.02
3	8	0		20.13	19.86	19.98
3	8	4		20.13	19.90	20.00
3	8	7		20.08	19.86	19.93
3	15	0		20.14	19.86	19.95
1.4	1	0	QPSK	22.56	22.79	22.56
1.4	1	3		22.54	22.77	22.54
1.4	1	5		22.49	22.74	22.49
1.4	3	0		22.37	22.58	22.37
1.4	3	1		22.40	22.62	22.40
1.4	3	3		22.36	22.56	22.36
1.4	6	0		21.58	21.80	21.58
1.4	1	0	16-QAM	21.96	22.10	21.96
1.4	1	3		21.92	22.10	21.92
1.4	1	5		21.86	22.02	21.86
1.4	3	0		21.62	21.77	21.62
1.4	3	1		21.65	21.76	21.65



1.4	3	3	64-QAM	21.58	21.70	21.58
1.4	6	0		20.69	20.88	20.69
1.4	1	0		21.12	21.23	21.12
1.4	1	3		21.11	21.24	21.11
1.4	1	5		21.02	21.16	21.02
1.4	3	0		20.86	21.02	20.86
1.4	3	1		20.88	21.02	20.88
1.4	3	3		20.81	20.97	20.81
1.4	6	0		19.95	20.15	19.95



LTE Band 26 Maximum Average Power [dBm]						
BW [MHz]	RB Size	RB Offset	Mod	Lowest	Middle	Highest
15	1	0	QPSK	23.05	23.10	23.14
15	1	37		23.18	23.13	23.10
15	1	74		23.09	23.07	22.96
15	36	0		22.24	22.23	22.07
15	36	20		22.21	22.20	22.08
15	36	39		22.14	22.21	21.98
15	75	0		22.19	22.18	22.07
15	1	0	16-QAM	22.40	22.35	22.56
15	1	37		22.59	22.55	22.31
15	1	74		22.49	22.45	22.29
15	36	0		21.32	21.30	21.18
15	36	20		21.33	21.34	21.11
15	36	39		21.25	21.23	21.10
15	75	0		21.29	21.25	21.10
15	1	0	64-QAM	21.55	21.50	21.73
15	1	37		21.74	21.62	21.47
15	1	74		21.66	21.62	21.50
15	36	0		20.59	20.57	20.45
15	36	20		20.60	20.55	20.37
15	36	39		20.52	20.51	20.36
15	75	0		20.57	20.54	20.37
10	1	0	QPSK	23.01	23.02	23.04
10	1	25		23.00	23.05	23.02
10	1	49		23.07	23.04	22.91
10	25	0		22.01	22.07	22.08
10	25	12		22.02	22.03	22.07
10	25	25		22.09	22.10	22.03
10	50	0		22.12	22.10	22.06
10	1	0	16-QAM	22.33	22.31	22.42
10	1	25		22.27	22.29	22.30
10	1	49		22.21	22.19	22.24
10	25	0		21.10	21.09	21.12
10	25	12		21.14	21.12	21.12



10	25	25	64-QAM	21.10	21.11	21.08
10	50	0		21.14	21.13	21.11
10	1	0		21.34	21.32	21.51
10	1	25		21.33	21.40	21.43
10	1	49		21.36	21.34	21.36
10	25	0		20.36	20.40	20.33
10	25	12		20.37	20.35	20.35
10	25	25		20.33	20.33	20.30
10	50	0		20.30	20.29	20.30



LTE Band 26 Maximum Average Power [dBm]						
BW [MHz]	RB Size	RB Offset	Mod	Lowest	Middle	Highest
5	1	0	QPSK	23.10	23.01	22.98
5	1	12		23.07	23.02	22.98
5	1	24		23.04	23.04	22.89
5	12	0		21.98	22.01	22.01
5	12	7		22.01	22.10	21.98
5	12	13		22.09	22.07	21.98
5	25	0		22.09	22.10	21.98
5	1	0	16-QAM	22.29	22.33	22.27
5	1	12		22.28	22.24	22.30
5	1	24		22.17	22.19	22.21
5	12	0		21.07	21.05	21.06
5	12	7		21.07	21.10	21.10
5	12	13		21.08	21.07	21.09
5	25	0		21.05	21.06	21.06
5	1	0	64-QAM	21.45	21.46	21.44
5	1	12		21.40	21.44	21.45
5	1	24		21.33	21.29	21.40
5	12	0		20.30	20.28	20.30
5	12	7		20.25	20.23	20.36
5	12	13		20.31	20.30	20.30
5	25	0		20.33	20.31	20.32
3	1	0	QPSK	22.98	23.01	23.01
3	1	8		23.01	23.04	23.09
3	1	14		23.04	23.01	23.06
3	8	0		22.14	22.15	22.13
3	8	4		22.14	22.13	22.12
3	8	7		22.11	22.09	22.12
3	15	0		22.10	22.08	22.09
3	1	0	16-QAM	22.23	22.40	22.35
3	1	8		22.19	22.33	22.49
3	1	14		22.45	22.44	22.52
3	8	0		21.18	21.23	21.12
3	8	4		21.00	20.98	20.98



3	8	7	64-QAM	21.01	20.89	20.97
3	15	0		21.03	20.93	20.94
3	1	0		21.10	21.21	21.32
3	1	8		21.30	21.23	21.33
3	1	14		21.19	21.22	21.28
3	8	0		20.17	20.15	20.18
3	8	4		20.14	20.13	20.24
3	8	7		20.15	20.12	20.18
3	15	0		20.20	20.17	20.20



LTE Band 26 Maximum Average Power [dBm]						
BW [MHz]	RB Size	RB Offset	Mod	Lowest	Middle	Highest
1.4	1	0	QPSK	23.02	23.01	23.05
1.4	1	3		23.01	23.09	23.13
1.4	1	5		22.99	23.00	23.10
1.4	3	0		22.99	22.92	22.95
1.4	3	1		23.02	22.98	22.94
1.4	3	3		23.01	22.97	22.94
1.4	6	0		22.10	22.19	22.13
1.4	1	0	16-QAM	22.18	22.21	22.39
1.4	1	3		22.19	22.29	22.53
1.4	1	5		22.32	22.30	22.56
1.4	3	0		21.99	22.07	21.94
1.4	3	1		21.89	22.09	21.80
1.4	3	3		21.82	21.89	21.77
1.4	6	0		20.99	20.95	20.96
1.4	1	0	64-QAM	21.30	21.21	21.34
1.4	1	3		21.32	21.22	21.35
1.4	1	5		21.29	21.19	21.30
1.4	3	0		21.21	21.22	21.34
1.4	3	1		21.09	21.19	21.04
1.4	3	3		21.13	21.11	21.34
1.4	6	0		20.10	20.07	20.22



LTE Band 38 Maximum Average Power [dBm]						
BW [MHz]	RB Size	RB Offset	Mod	Lowest	Middle	Highest
20	1	0	QPSK	22.60	22.82	22.61
20	1	49		22.55	22.64	22.73
20	1	99		22.76	22.71	22.81
20	50	0		21.65	21.82	21.68
20	50	24		21.69	21.71	21.79
20	50	50		21.78	21.69	21.81
20	100	0		21.75	21.76	21.65
20	1	0	16-QAM	21.74	21.81	21.78
20	1	49		21.76	21.80	21.95
20	1	99		21.88	21.89	21.99
20	50	0		20.73	20.82	20.79
20	50	24		20.77	20.81	20.89
20	50	50		20.84	20.82	20.95
20	100	0		20.85	20.78	20.75
20	1	0	64-QAM	20.76	20.83	20.78
20	1	49		20.76	20.87	20.85
20	1	99		20.89	20.92	21.01
20	50	0		19.94	20.03	19.97
20	50	24		19.97	20.03	20.10
20	50	50		20.03	20.04	20.11
20	100	0		20.17	20.09	20.09
15	1	0	QPSK	22.63	22.70	22.74
15	1	37		22.64	22.68	22.71
15	1	74		22.69	22.78	22.67
15	36	0		21.64	21.68	21.75
15	36	20		21.70	21.68	21.80
15	36	39		21.66	21.72	21.78
15	75	0		21.67	21.68	21.77
15	1	0	16-QAM	21.78	21.81	21.86
15	1	37		21.76	21.85	21.96
15	1	74		21.84	21.88	22.04
15	36	0		20.67	20.77	20.81
15	36	20		20.71	20.76	20.88
15	36	39		20.73	20.80	20.89



15	75	0		20.71	20.80	20.88
15	1	0	64-QAM	20.78	20.80	20.88
15	1	37		20.75	20.85	20.92
15	1	74		20.85	20.92	21.04
15	36	0		19.99	20.07	20.11
15	36	20		20.02	20.09	20.20
15	36	39		20.02	20.05	20.18
15	75	0		19.98	20.10	20.12



LTE Band 38 Maximum Average Power [dBm]						
BW [MHz]	RB Size	RB Offset	Mod	Lowest	Middle	Highest
10	1	0	QPSK	22.65	22.62	22.72
10	1	25		22.57	22.66	22.72
10	1	49		22.63	22.73	22.77
10	25	0		21.62	21.62	21.69
10	25	12		21.66	21.67	21.73
10	25	25		21.63	21.64	21.73
10	50	0		21.65	21.68	21.74
10	1	0	16-QAM	21.73	21.77	21.85
10	1	25		21.71	21.84	21.89
10	1	49		21.75	21.79	21.87
10	25	0		20.71	20.75	20.82
10	25	12		20.73	20.78	20.87
10	25	25		20.73	20.80	20.91
10	50	0		20.74	20.79	20.86
10	1	0	64-QAM	20.75	20.79	20.86
10	1	25		20.72	20.82	20.86
10	1	49		20.77	20.82	20.92
10	25	0		19.94	19.97	20.05
10	25	12		19.96	19.98	20.08
10	25	25		19.95	19.98	20.08
10	50	0		19.93	20.01	20.06
5	1	0	QPSK	22.56	22.64	22.67
5	1	12		22.65	22.63	22.75
5	1	24		22.61	22.64	22.70
5	12	0		21.62	21.68	21.72
5	12	7		21.68	21.70	21.75
5	12	13		21.63	21.64	21.75
5	25	0		21.65	21.66	21.72
5	1	0	16-QAM	21.71	21.76	21.82
5	1	12		21.75	21.78	21.88
5	1	24		21.75	21.79	21.91
5	12	0		20.63	20.72	20.76
5	12	7		20.68	20.72	20.80



5	12	13	64-QAM	20.65	20.73	20.83
5	25	0		20.72	20.79	20.85
5	1	0		20.74	20.80	20.85
5	1	12		20.74	20.78	20.93
5	1	24		20.82	20.83	20.91
5	12	0		19.90	19.95	20.04
5	12	7		19.95	20.00	20.11
5	12	13		19.93	20.00	20.08
5	25	0		19.94	19.99	20.06



LTE Band 41 Maximum Average Power [dBm]						
BW [MHz]	RB Size	RB Offset	Mod	Lowest	Middle	Highest
20	1	0	QPSK	26.24	25.78	26.18
20	1	49		25.90	25.70	26.06
20	1	99		25.91	25.82	26.02
20	50	0		24.99	24.88	25.16
20	50	24		25.06	24.79	25.09
20	50	50		25.02	24.89	25.08
20	100	0		25.09	24.91	25.05
20	1	0	16-QAM	25.27	24.96	25.44
20	1	49		25.15	25.03	25.41
20	1	99		25.21	25.07	25.23
20	50	0		24.11	23.93	24.28
20	50	24		24.18	23.98	24.21
20	50	50		24.14	23.99	24.20
20	100	0		24.20	24.08	24.21
20	1	0	64-QAM	24.23	23.88	24.34
20	1	49		24.04	23.87	24.29
20	1	99		24.07	23.93	24.13
20	50	0		23.04	22.90	23.19
20	50	24		23.17	22.87	23.15
20	50	50		23.04	22.93	23.12
20	100	0		23.24	23.08	23.25
15	1	0	QPSK	25.95	25.67	26.14
15	1	37		25.84	25.69	25.97
15	1	74		25.96	25.75	25.91
15	36	0		24.94	24.78	25.15
15	36	20		25.00	24.80	25.07
15	36	39		25.02	24.81	25.05
15	75	0		25.02	24.90	25.11
15	1	0	16-QAM	25.28	25.04	25.41
15	1	37		25.23	25.01	25.35
15	1	74		25.24	25.10	25.31
15	36	0		24.05	23.93	24.26
15	36	20		24.08	23.87	24.18



15	36	39	64-QAM	24.13	23.91	24.16
15	75	0		24.20	24.06	24.23
15	1	0		24.17	23.97	24.40
15	1	37		24.04	23.96	24.24
15	1	74		24.22	23.94	24.18
15	36	0		23.07	22.91	23.27
15	36	20		23.09	22.92	23.20
15	36	39		23.14	22.96	23.20
15	75	0		23.16	23.01	23.21



LTE Band 41 Maximum Average Power [dBm]						
BW [MHz]	RB Size	RB Offset	Mod	Lowest	Middle	Highest
10	1	0	QPSK	25.83	25.71	26.03
10	1	25		25.84	25.68	25.97
10	1	49		25.79	25.64	25.98
10	25	0		24.94	24.81	25.04
10	25	12		24.96	24.78	25.03
10	25	25		24.94	24.76	25.07
10	50	0		24.95	24.80	25.08
10	1	0	16-QAM	25.23	25.03	25.39
10	1	25		25.20	25.00	25.30
10	1	49		25.10	24.96	25.32
10	25	0		24.07	23.92	24.23
10	25	12		24.12	23.91	24.25
10	25	25		24.07	23.92	24.14
10	50	0		24.07	23.95	24.20
10	1	0	64-QAM	24.12	23.96	24.31
10	1	25		24.04	23.89	24.22
10	1	49		23.99	23.89	24.16
10	25	0		23.05	22.90	23.15
10	25	12		23.03	22.90	23.19
10	25	25		23.01	22.84	23.12
10	50	0		22.99	22.86	23.15
5	1	0	QPSK	25.84	25.72	25.98
5	1	12		25.84	25.68	25.97
5	1	24		25.78	25.66	25.92
5	12	0		24.95	24.83	25.02
5	12	7		24.99	24.84	25.08
5	12	13		24.99	24.80	25.00
5	25	0		24.90	24.81	25.02
5	1	0	16-QAM	25.18	24.98	25.28
5	1	12		25.16	25.03	25.31
5	1	24		25.14	24.97	25.24
5	12	0		24.07	23.94	24.20
5	12	7		24.13	23.94	24.19



5	12	13	64-QAM	24.04	23.92	24.10
5	25	0		24.07	23.95	24.18
5	1	0		24.09	23.89	24.18
5	1	12		24.05	23.91	24.17
5	1	24		24.06	23.86	24.14
5	12	0		23.03	22.84	23.16
5	12	7		23.06	22.88	23.12
5	12	13		22.97	22.86	23.12
5	25	0		23.02	22.87	23.08



LTE Band 66 Maximum Average Power [dBm]						
BW [MHz]	RB Size	RB Offset	Mod	Lowest	Middle	Highest
20	1	0	QPSK	22.42	22.53	22.61
20	1	49		22.32	22.35	22.38
20	1	99		22.35	22.31	22.42
20	50	0		21.61	21.56	21.70
20	50	24		21.66	21.64	21.35
20	50	50		21.67	21.70	21.47
20	100	0		21.61	21.85	21.70
20	1	0	16-QAM	21.76	21.77	21.82
20	1	49		21.71	21.49	21.60
20	1	99		21.68	21.65	21.77
20	50	0		20.71	20.79	20.94
20	50	24		20.68	20.74	20.85
20	50	50		20.66	20.81	20.76
20	100	0		20.72	20.60	20.70
20	1	0	64-QAM	20.94	20.89	20.98
20	1	49		21.03	21.32	21.13
20	1	99		20.86	20.97	20.89
20	50	0		19.80	20.03	19.92
20	50	24		19.72	19.93	19.88
20	50	50		19.81	19.98	20.12
20	100	0		19.93	19.82	19.70
15	1	0	QPSK	22.48	22.32	22.49
15	1	37		22.30	22.22	22.26
15	1	74		22.26	22.25	22.30
15	36	0		21.51	21.51	21.58
15	36	20		21.59	21.56	21.23
15	36	39		21.65	21.57	21.35
15	75	0		21.80	21.51	21.58
15	1	0	16-QAM	21.72	21.66	21.70
15	1	37		21.44	21.61	21.48
15	1	74		21.60	21.58	21.65
15	36	0		20.74	20.61	20.82



15	36	20		20.69	20.58	20.73
15	36	39		20.76	20.56	20.64
15	75	0		20.55	20.62	20.58
15	1	0	64-QAM	20.84	20.84	20.86
15	1	37		21.25	20.93	21.01
15	1	74		20.92	20.76	20.77
15	36	0		19.98	19.70	19.80
15	36	20		19.88	19.62	19.76
15	36	39		19.93	19.71	20.00
15	75	0		19.77	19.83	19.58



LTE Band 66 Maximum Average Power [dBm]						
BW [MHz]	RB Size	RB Offset	Mod	Lowest	Middle	Highest
10	1	0	QPSK	22.53	22.38	22.40
10	1	25		22.35	22.20	22.22
10	1	49		22.31	22.16	22.18
10	25	0		21.56	21.41	21.43
10	25	12		21.64	21.49	21.51
10	25	25		21.70	21.55	21.57
10	50	0		21.85	21.70	21.72
10	1	0	16-QAM	21.77	21.62	21.64
10	1	25		21.49	21.34	21.36
10	1	49		21.72	21.57	21.59
10	25	0		20.89	20.74	20.76
10	25	12		20.80	20.65	20.67
10	25	25		20.71	20.56	20.58
10	50	0		20.65	20.50	20.52
10	1	0	64-QAM	20.93	20.78	20.80
10	1	25		21.08	20.93	20.95
10	1	49		20.84	20.69	20.71
10	25	0		19.87	19.72	19.74
10	25	12		19.83	19.68	19.70
10	25	25		20.07	19.92	19.94
10	50	0		19.65	19.50	19.52
5	1	0	QPSK	22.30	22.48	22.55
5	1	12		22.38	22.30	22.37
5	1	24		22.42	22.26	22.33
5	12	0		21.70	21.51	21.58
5	12	7		21.35	21.59	21.66
5	12	13		21.47	21.65	21.72
5	25	0		21.70	21.80	21.87
5	1	0	16-QAM	21.82	21.72	21.79
5	1	12		21.60	21.44	21.51
5	1	24		21.58	21.67	21.74
5	12	0		20.61	20.84	20.91
5	12	7		20.58	20.75	20.82



5	12	13	64-QAM	20.56	20.66	20.73
5	25	0		20.62	20.60	20.67
5	1	0		20.84	20.88	20.95
5	1	12		20.93	21.03	21.10
5	1	24		20.76	20.79	20.86
5	12	0		19.70	19.82	19.89
5	12	7		19.62	19.78	19.85
5	12	13		19.71	20.02	20.09
5	25	0		19.83	19.60	19.67



LTE Band 66 Maximum Average Power [dBm]						
BW [MHz]	RB Size	RB Offset	Mod	Lowest	Middle	Highest
3	1	0	QPSK	22.45	22.53	22.34
3	1	8		22.29	22.37	22.18
3	1	14		22.25	22.33	22.14
3	8	0		21.50	21.58	21.39
3	8	4		21.58	21.66	21.47
3	8	7		21.64	21.72	21.53
3	15	0		21.79	21.87	21.68
3	1	0	16-QAM	21.71	21.79	21.60
3	1	8		21.43	21.51	21.32
3	1	14		21.66	21.74	21.55
3	8	0		20.81	20.89	20.70
3	8	4		20.72	20.80	20.61
3	8	7		20.63	20.71	20.52
3	15	0		20.57	20.65	20.46
3	1	0	64-QAM	20.85	20.93	20.74
3	1	8		21.02	21.10	20.91
3	1	14		20.78	20.86	20.67
3	8	0		19.81	19.89	19.70
3	8	4		19.77	19.85	19.66
3	8	7		20.01	20.09	19.90
3	15	0		19.59	19.67	19.48
1.4	1	0	QPSK	22.47	22.24	22.33
1.4	1	3		22.26	22.08	22.12
1.4	1	5		22.30	22.04	22.16
1.4	3	0		22.36	22.07	22.22
1.4	3	1		22.01	22.15	22.12
1.4	3	3		22.13	22.21	22.20
1.4	6	0		21.58	21.58	21.44
1.4	1	0	16-QAM	21.70	21.50	21.56
1.4	1	3		21.48	21.22	21.34
1.4	1	5		21.46	21.45	21.32
1.4	3	0		21.25	21.38	21.11
1.4	3	1		21.22	21.29	21.08



1.4	3	3	64-QAM	21.20	21.20	21.06
1.4	6	0		20.48	20.36	20.34
1.4	1	0		20.70	20.64	20.56
1.4	1	3		20.81	20.81	20.67
1.4	1	5		20.64	20.57	20.50
1.4	3	0		20.36	20.38	20.22
1.4	3	1		20.28	20.34	20.14
1.4	3	3		20.37	20.58	20.23
1.4	6	0		19.71	19.38	19.57



LTE Band 71 Maximum Average Power [dBm]						
BW [MHz]	RB Size	RB Offset	Mod	Lowest	Middle	Highest
20	1	0	QPSK	23.45	23.45	23.50
20	1	49		23.38	23.34	23.37
20	1	99		23.27	23.22	23.11
20	50	0		22.48	22.49	22.35
20	50	24		22.41	22.38	22.31
20	50	50		22.39	22.26	22.33
20	100	0		22.40	22.36	22.29
20	1	0	16-QAM	22.75	22.77	22.76
20	1	49		22.69	22.75	22.74
20	1	99		22.64	22.56	22.53
20	50	0		21.57	21.59	21.48
20	50	24		21.55	21.49	21.39
20	50	50		21.51	21.38	21.36
20	100	0		21.47	21.49	21.38
20	1	0	64-QAM	21.79	21.88	21.94
20	1	49		21.80	21.86	21.86
20	1	99		21.79	21.71	21.58
20	50	0		20.80	20.75	20.70
20	50	24		20.73	20.70	20.61
20	50	50		20.72	20.53	20.58
20	100	0		20.73	20.66	20.61
15	1	0	QPSK	23.43	23.43	23.41
15	1	37		23.29	23.36	23.32
15	1	74		23.22	23.37	23.17
15	36	0		22.42	22.45	22.33
15	36	20		22.45	22.41	22.42
15	36	39		22.38	22.31	22.28
15	75	0		22.46	22.41	22.26
15	1	0	16-QAM	22.77	22.78	22.71
15	1	37		22.55	22.74	22.65
15	1	74		22.57	22.76	22.61
15	36	0		21.50	21.58	21.45
15	36	20		21.57	21.54	21.50



15	36	39	64-QAM	21.44	21.41	21.38
15	75	0		21.49	21.51	21.37
15	1	0		21.93	21.91	21.88
15	1	37		21.77	21.86	21.82
15	1	74		21.70	21.83	21.53
15	36	0		20.73	20.82	20.65
15	36	20		20.81	20.75	20.68
15	36	39		20.64	20.65	20.55
15	75	0		20.73	20.71	20.54



LTE Band 71 Maximum Average Power [dBm]						
BW [MHz]	RB Size	RB Offset	Mod	Lowest	Middle	Highest
10	1	0	QPSK	23.39	23.46	23.37
10	1	25		23.38	23.45	23.33
10	1	49		23.31	23.31	23.21
10	25	0		22.45	22.54	22.37
10	25	12		22.39	22.49	22.31
10	25	25		22.40	22.39	22.30
10	50	0		22.47	22.47	22.31
10	1	0	16-QAM	22.78	22.70	22.82
10	1	25		22.75	22.76	22.69
10	1	49		22.66	22.62	22.63
10	25	0		21.56	21.65	21.51
10	25	12		21.52	21.61	21.45
10	25	25		21.54	21.54	21.35
10	50	0		21.53	21.56	21.42
10	1	0	64-QAM	21.87	21.85	21.86
10	1	25		21.78	21.81	21.77
10	1	49		21.79	21.83	21.59
10	25	0		20.71	20.81	20.74
10	25	12		20.74	20.78	20.67
10	25	25		20.68	20.70	20.56
10	50	0		20.76	20.80	20.65
5	1	0	QPSK	23.38	23.40	23.31
5	1	12		23.34	23.35	23.29
5	1	24		23.33	23.43	23.16
5	12	0		22.45	22.41	22.30
5	12	7		22.45	22.45	22.35
5	12	13		22.40	22.52	22.27
5	25	0		22.40	22.53	22.29
5	1	0	16-QAM	22.78	22.72	22.65
5	1	12		22.69	22.67	22.57
5	1	24		22.65	22.73	22.47
5	12	0		21.56	21.54	21.42
5	12	7		21.56	21.52	21.41



5	12	13		21.53	21.58	21.41
5	25	0		21.51	21.58	21.41
5	1	0	64-QAM	21.87	21.94	21.76
5	1	12		21.82	21.88	21.68
5	1	24		21.80	21.82	21.66
5	12	0		20.77	20.74	20.64
5	12	7		20.75	20.75	20.64
5	12	13		20.70	20.80	20.55
5	25	0		20.73	20.85	20.61



CA Power

CA_41C							
Combination 20MHz+20MHz (100RB+100RB)							
PCC Channel	SCC Channel	Modulation	PCC		SCC		Measured Power (dBm)
			RB Size	RB offset	RB Size	RB offset	
39750	39948	QPSK	100	0	100	0	22.63
			1	0	1	99	16.08
			1	99	1	0	24.33
		16QAM	100	0	100	0	21.65
			1	0	1	99	16.13
			1	99	1	0	23.74
		64QAM	100	0	100	0	21.68
			1	0	1	99	15.95
			1	99	1	0	23.55
40521	40719	QPSK	100	0	100	0	22.62
			1	0	1	99	16.03
			1	99	1	0	24.32
		16QAM	100	0	100	0	21.68
			1	0	1	99	16.11
			1	99	1	0	23.69
		64QAM	100	0	100	0	21.68
			1	0	1	99	15.91
			1	99	1	0	21.49
41292	41490	QPSK	100	0	100	0	22.56
			1	0	1	99	16
			1	99	1	0	24.35
		16QAM	100	0	100	0	21.62
			1	0	1	99	16.06
			1	99	1	0	23.84
		64QAM	100	0	100	0	21.62
			1	0	1	99	15.86
			1	99	1	0	21.61



LTE Band 7

Peak-to-Average Ratio

Mode	LTE Band 7 / 20MHz				
Mod.	QPSK		16QAM		Limit: 13dB
RB Size	1RB	Full RB	1RB	Full RB	Result
Lowest CH	3.59	4.49	5.33	5.83	PASS
Middle CH	3.22	4.49	4.81	5.77	
Highest CH	3.71	4.55	5.71	5.88	
Mode	LTE Band 7 / 20MHz				
Mod.	64QAM				Limit: 13dB
RB Size	1RB	Full RB			Result
Lowest CH	7.07	6.35	-	-	PASS
Middle CH	6.43	6.26	-	-	
Highest CH	6.67	6.46	-	-	



LTE Band 7 / 20MHz / QPSK

Lowest Channel / 1RB

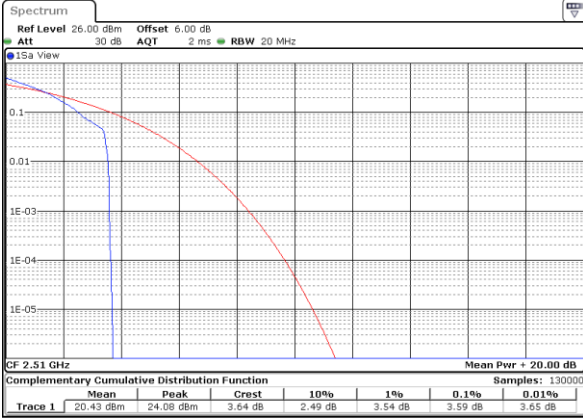

Date: 27 JAN 2020 16:18:04

Lowest Channel / Full RB

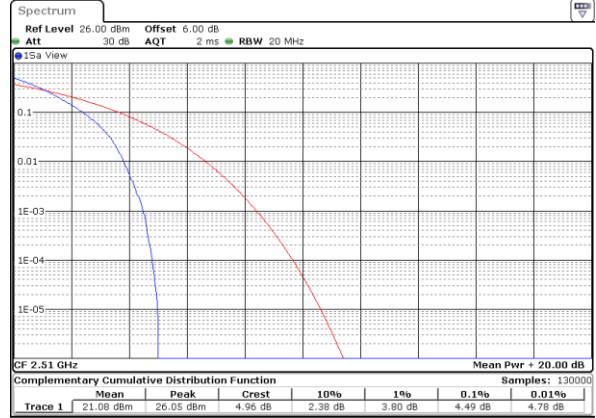

Date: 27 JAN 2020 16:18:14

Middle Channel / 1RB



Date: 27 JAN 2020 16:18:50

Middle Channel / Full RB

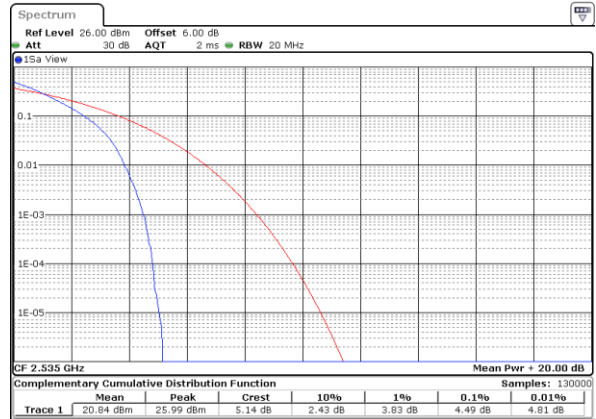

Date: 27 JAN 2020 16:18:41

Highest Channel / 1RB

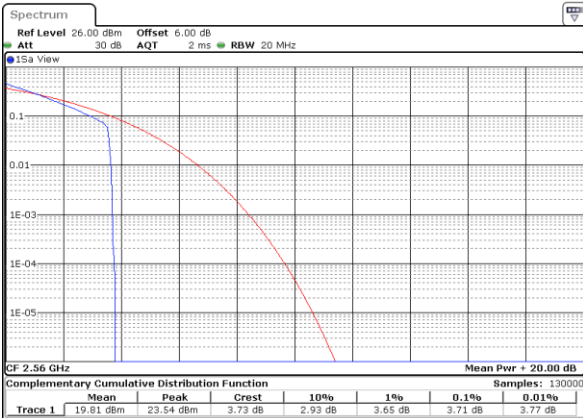

Date: 27 JAN 2020 16:19:18

Highest Channel / Full RB

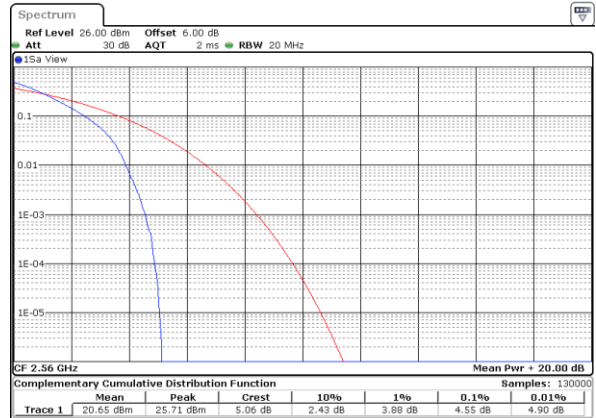

Date: 27 JAN 2020 16:19:27



LTE Band 7 / 20MHz / 16QAM

Lowest Channel / 1RB

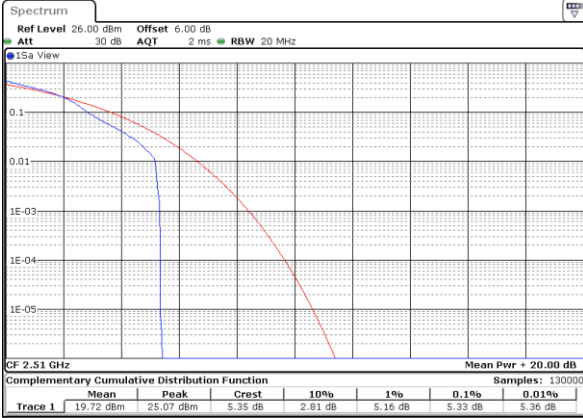

Date: 27 JAN 2020 16:17:54

Lowest Channel / Full RB

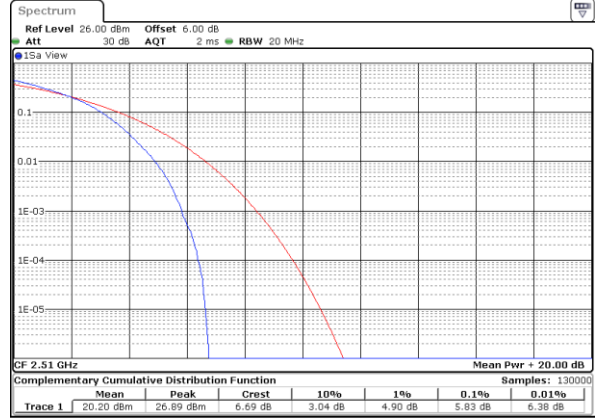

Date: 27 JAN 2020 16:18:23

Middle Channel / 1RB

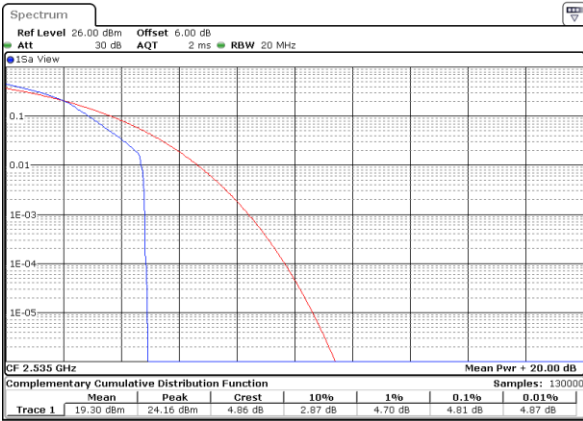

Date: 27 JAN 2020 16:19:00

Middle Channel / Full RB

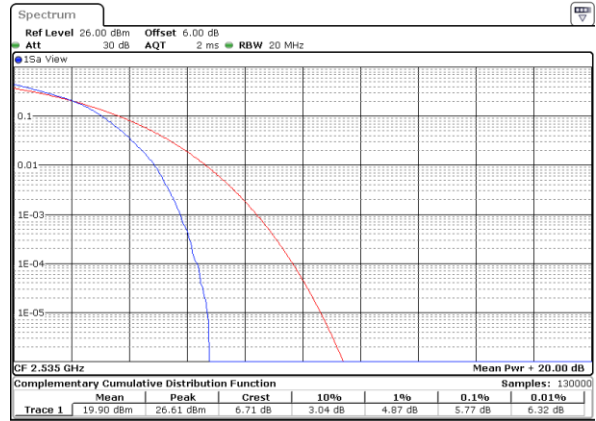

Date: 27 JAN 2020 16:18:32

Highest Channel / 1RB

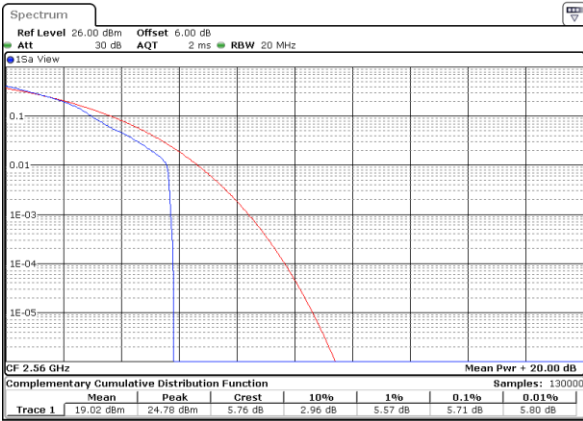

Date: 27 JAN 2020 16:19:10

Highest Channel / Full RB

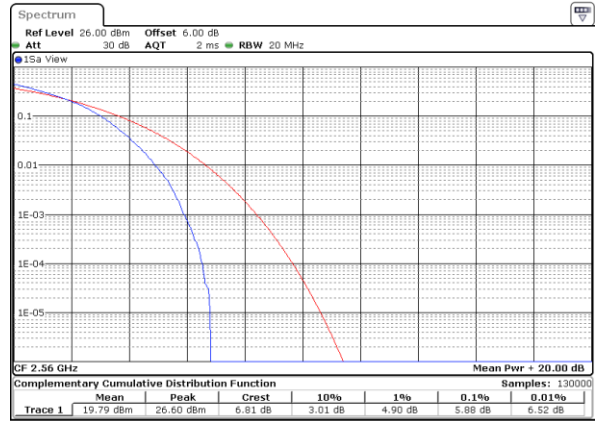

Date: 27 JAN 2020 16:19:37



LTE Band 7 / 20MHz / 64QAM

Lowest Channel / 1RB

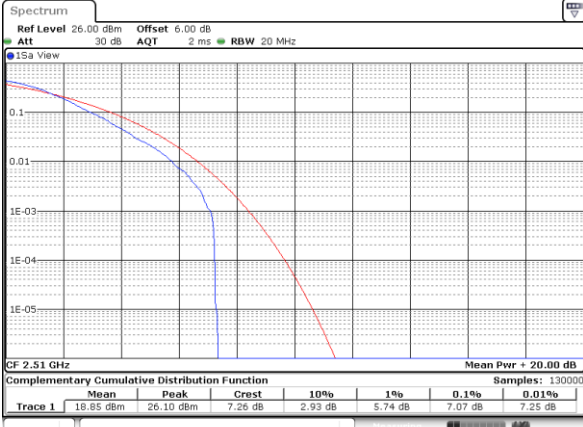

Date: 27 JAN 2020 16:16:31

Lowest Channel / Full RB

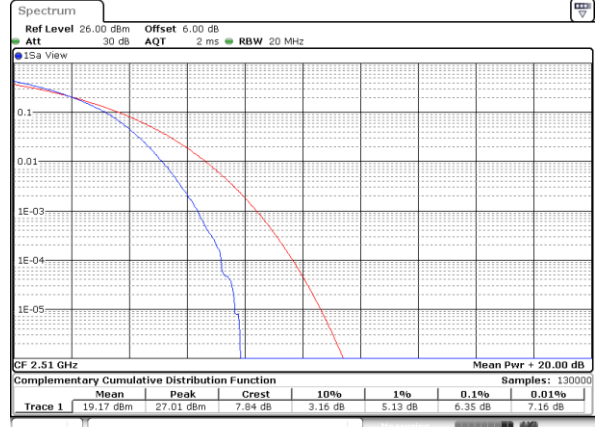

Date: 27 JAN 2020 16:16:40

Middle Channel / 1RB

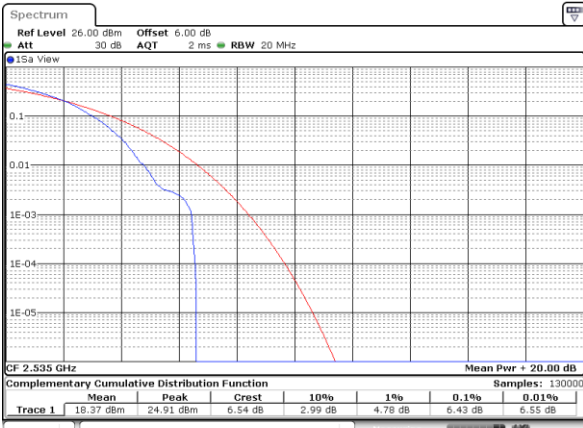

Date: 27 JAN 2020 16:17:06

Middle Channel / Full RB

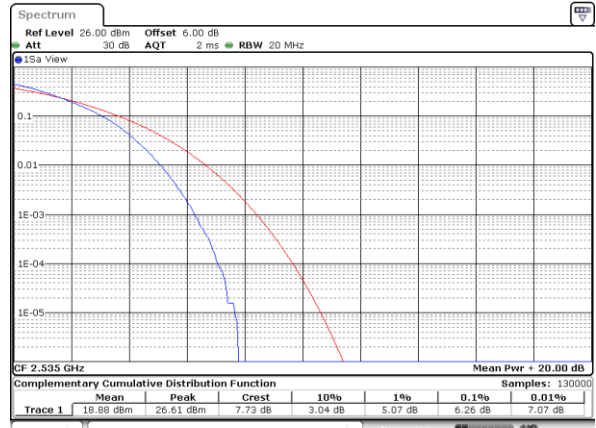

Date: 27 JAN 2020 16:16:57

Highest Channel / 1RB

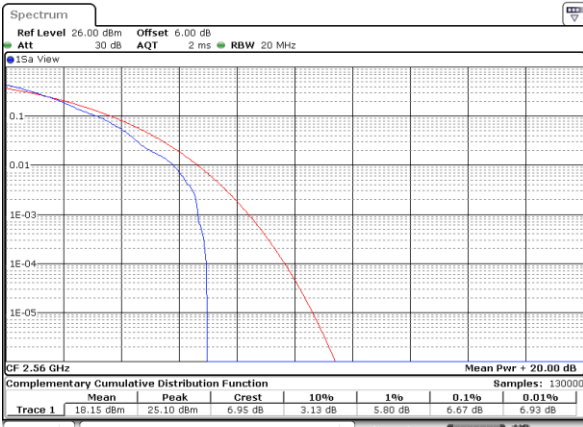

Date: 27 JAN 2020 16:17:33

Highest Channel / Full RB

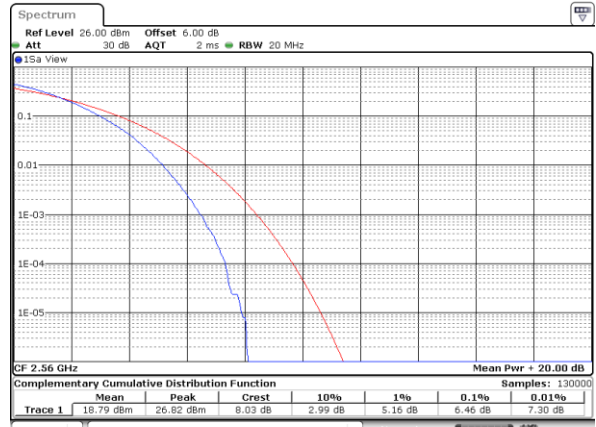

Date: 27 JAN 2020 16:17:43



26dB Bandwidth

Mode	LTE Band 7 : 26dB BW(MHz)											
BW	1.4MHz		3MHz		5MHz		10MHz		15MHz		20MHz	
Mod.	QPSK	16QAM	QPSK	16QAM	QPSK	16QAM	QPSK	16QAM	QPSK	16QAM	QPSK	16QAM
Lowest CH	-	-	-	-	4.94	4.91	9.73	9.79	14.30	14.45	20.10	20.18
Middle CH	-	-	-	-	4.94	4.85	9.67	9.73	14.42	14.42	20.18	20.22
Highest CH	-	-	-	-	4.98	4.89	9.79	9.75	14.60	14.57	20.26	20.26
Mode	LTE Band 7 : 26dB BW(MHz)											
BW	1.4MHz		3MHz		5MHz		10MHz		15MHz		20MHz	
Mod.	64QAM		64QAM		64QAM		64QAM		64QAM		64QAM	
Lowest CH	-	-	-	-	4.87	-	9.87	-	14.57	-	20.10	-
Middle CH	-	-	-	-	4.83	-	9.71	-	14.42	-	20.26	-
Highest CH	-	-	-	-	4.92	-	9.73	-	14.39	-	20.22	-



LTE Band 7

Lowest Channel / 5MHz / QPSK

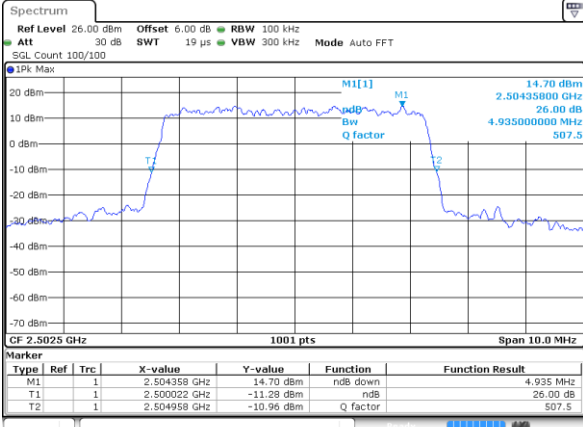

Date: 27 JAN 2020 14:31:24

Lowest Channel / 5MHz / 16QAM

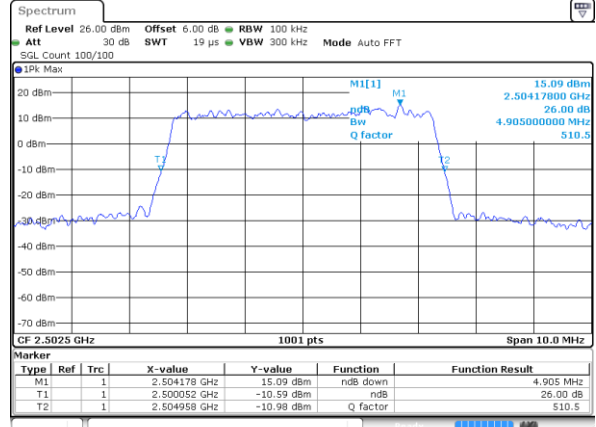

Date: 27 JAN 2020 14:31:44

Middle Channel / 5MHz / QPSK

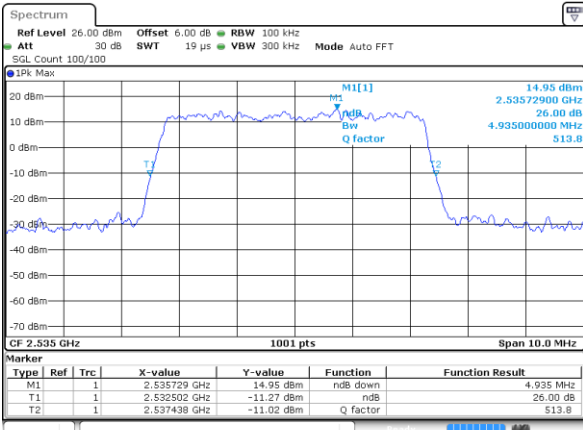

Date: 27 JAN 2020 14:32:25

Middle Channel / 5MHz / 16QAM

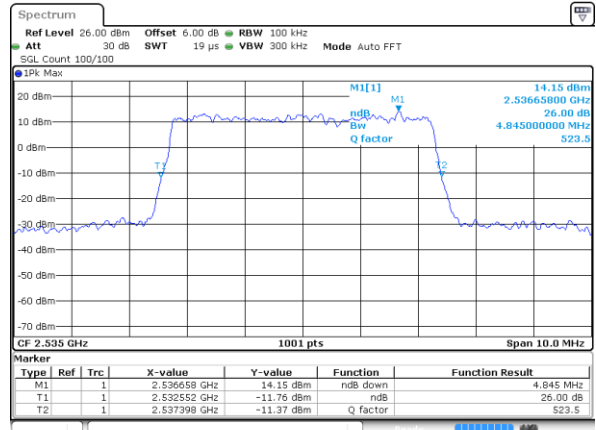

Date: 27 JAN 2020 14:32:04

Highest Channel / 5MHz / QPSK

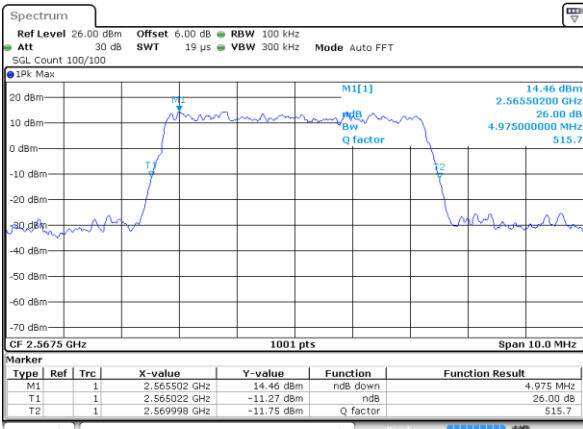

Date: 27 JAN 2020 14:32:45

Highest Channel / 5MHz / 16QAM

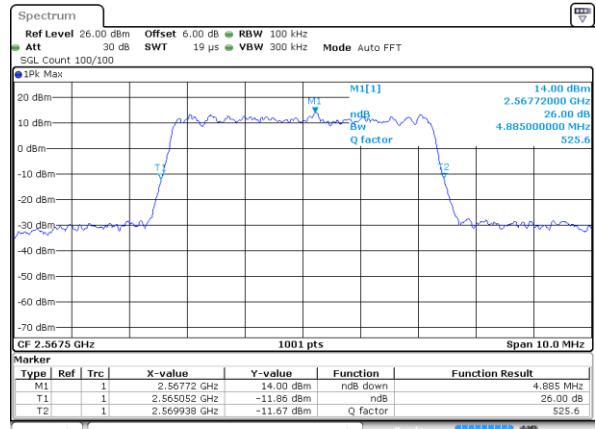

Date: 27 JAN 2020 14:33:05



LTE Band 7

Lowest Channel / 10MHz / QPSK

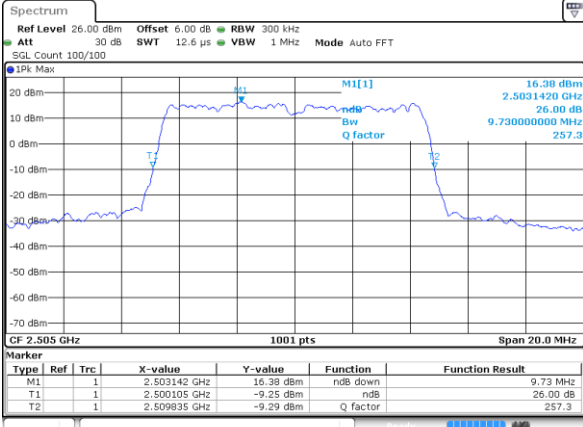

Date: 27 JAN 2020 14:47:58

Lowest Channel / 10MHz / 16QAM

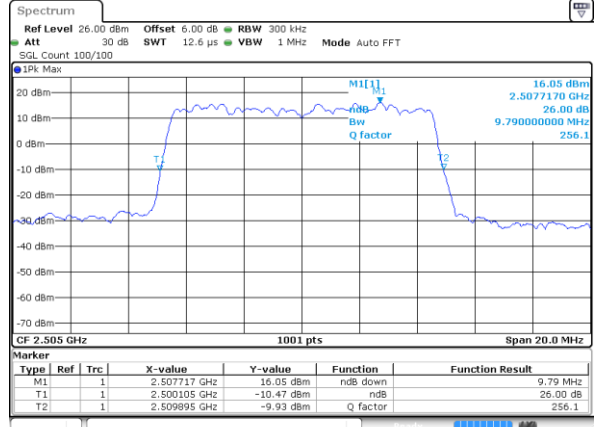

Date: 27 JAN 2020 14:48:19

Middle Channel / 10MHz / QPSK

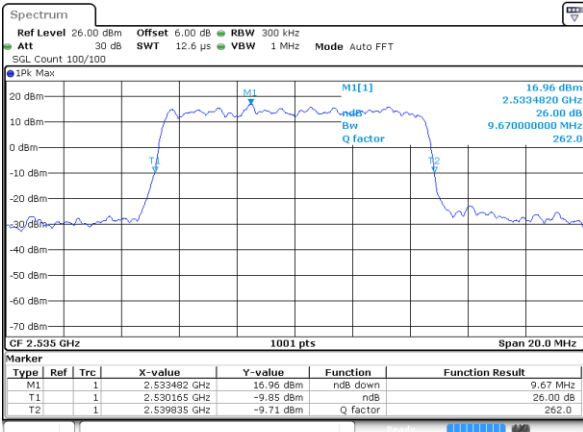

Date: 27 JAN 2020 14:48:59

Middle Channel / 10MHz / 16QAM

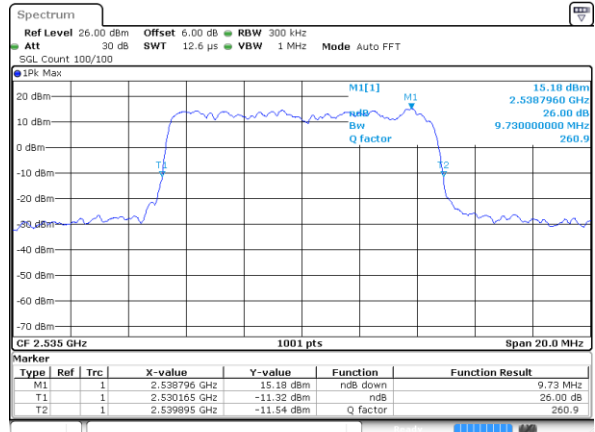

Date: 27 JAN 2020 14:48:39

Highest Channel / 10MHz / QPSK

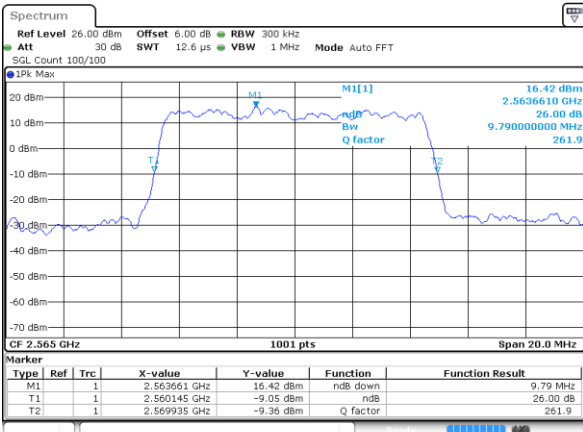

Date: 27 JAN 2020 14:49:20

Highest Channel / 10MHz / 16QAM

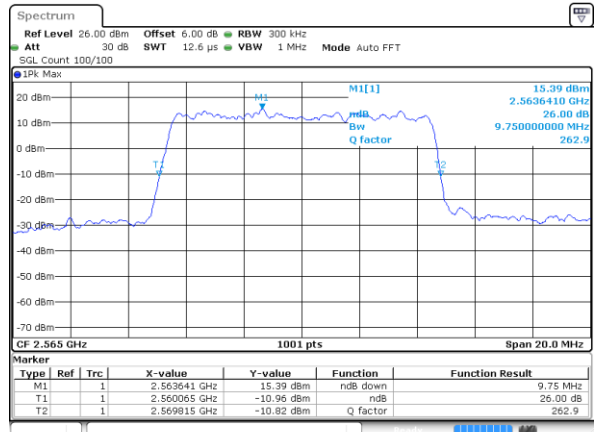

Date: 27 JAN 2020 14:49:40



LTE Band 7

Lowest Channel / 15MHz / QPSK

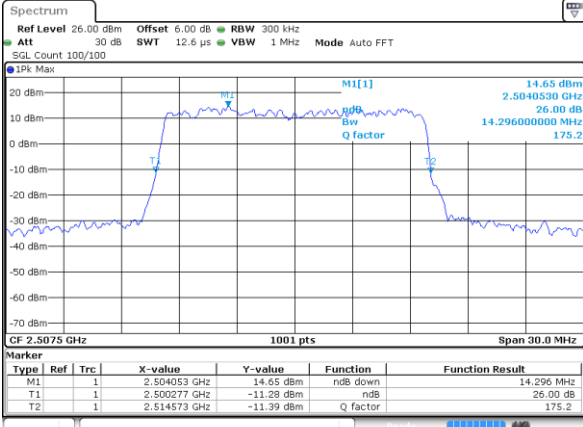

Date: 27 JAN 2020 15:04:52

Lowest Channel / 15MHz / 16QAM

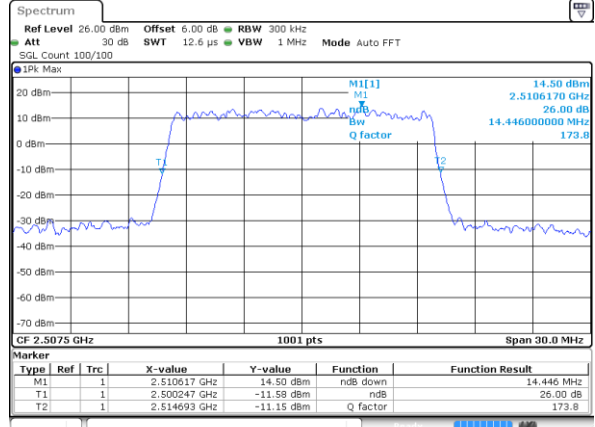

Date: 27 JAN 2020 15:04:31

Middle Channel / 15MHz / QPSK

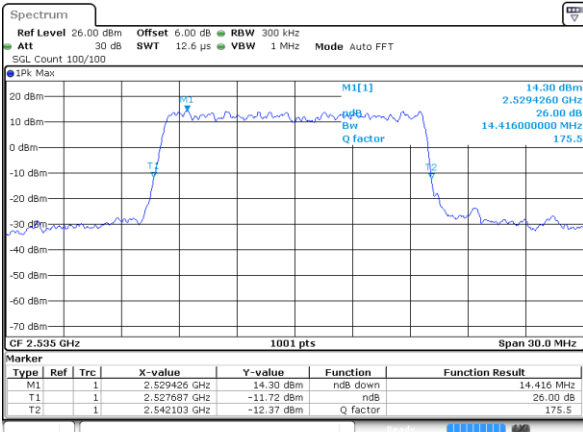

Date: 27 JAN 2020 15:05:12

Middle Channel / 15MHz / 16QAM

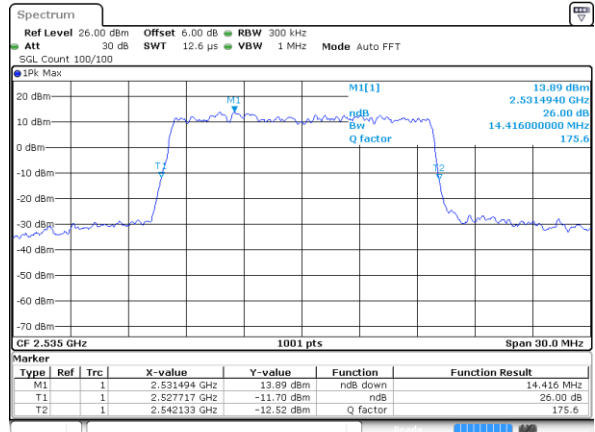

Date: 27 JAN 2020 15:05:32

Highest Channel / 15MHz / QPSK

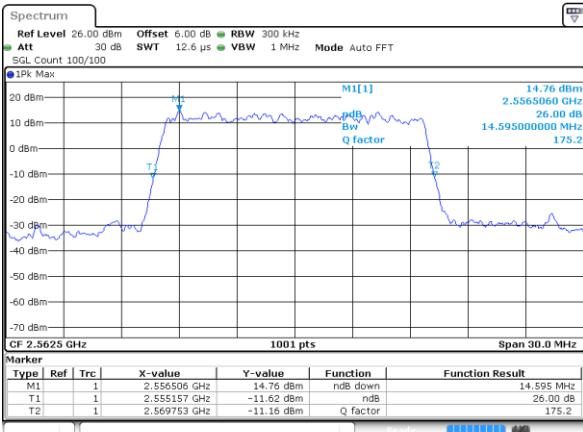

Date: 27 JAN 2020 15:06:13

Highest Channel / 15MHz / 16QAM

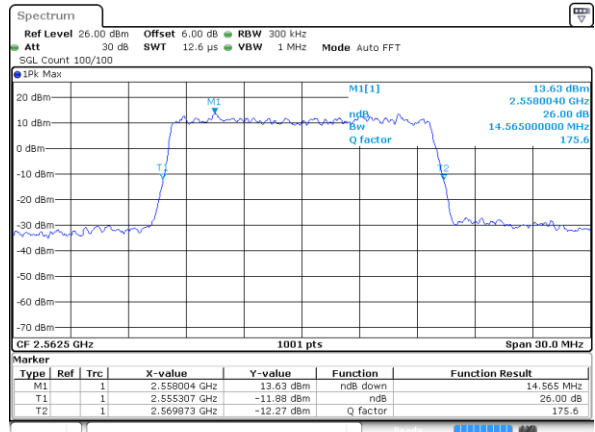

Date: 27 JAN 2020 15:05:53



LTE Band 7

Lowest Channel / 20MHz / QPSK

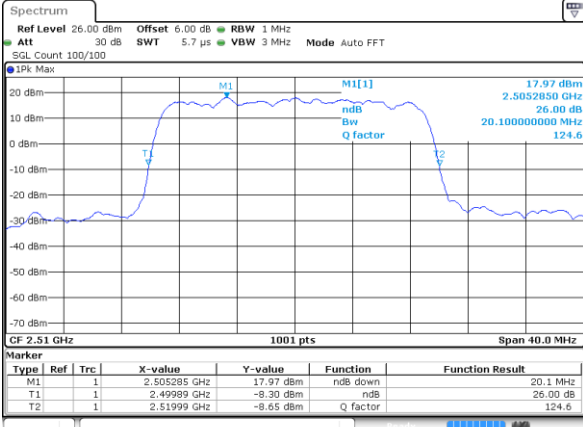

Date: 27 JAN 2020 15:21:26

Lowest Channel / 20MHz / 16QAM

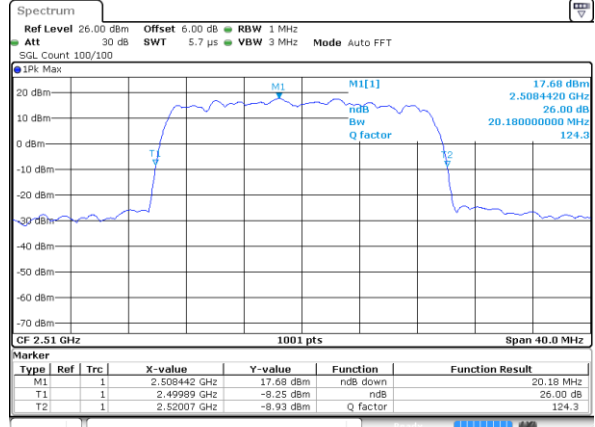

Date: 27 JAN 2020 15:21:05

Middle Channel / 20MHz / QPSK

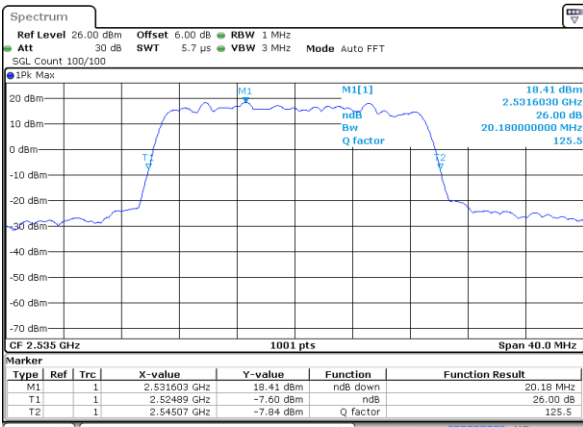

Date: 27 JAN 2020 15:21:46

Middle Channel / 20MHz / 16QAM

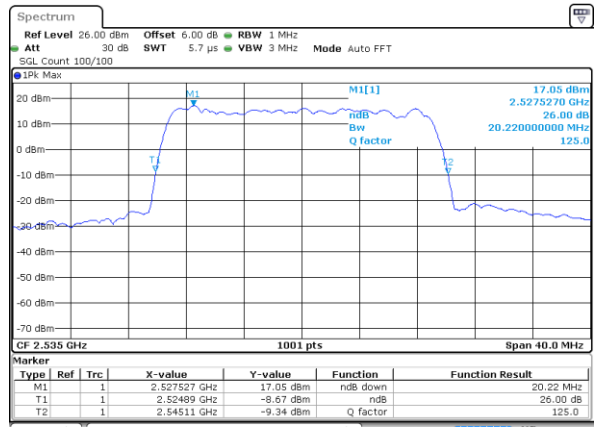

Date: 27 JAN 2020 15:22:06

Highest Channel / 20MHz / QPSK

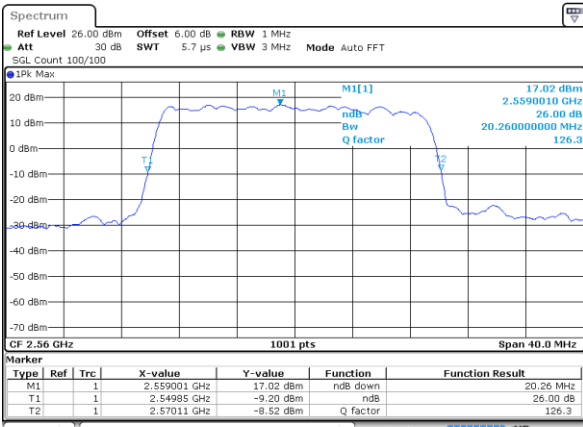

Date: 27 JAN 2020 15:22:47

Highest Channel / 20MHz / 16QAM

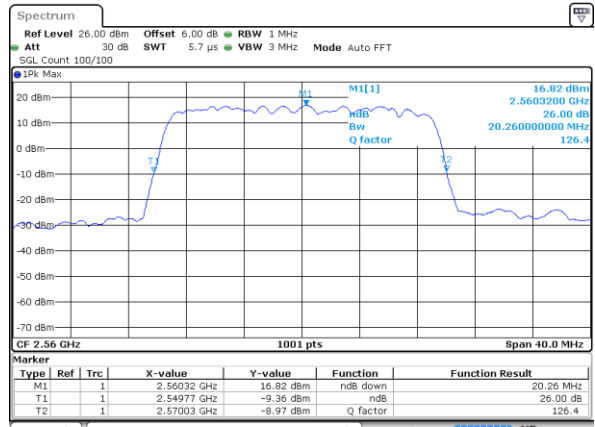

Date: 27 JAN 2020 15:22:27



LTE Band 7

Lowest Channel / 5MHz / 64QAM

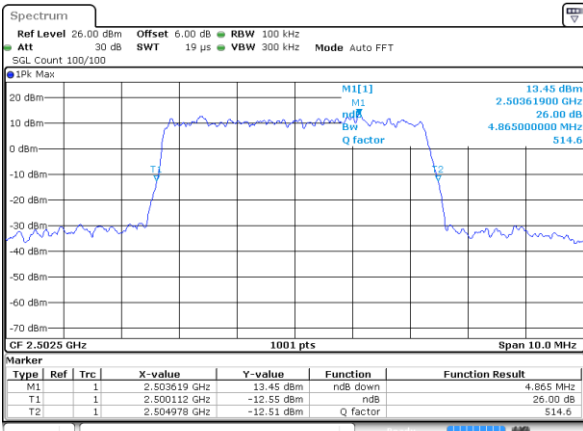

Date: 27 JAN 2020 15:38:00

Lowest Channel / 10MHz / 64QAM

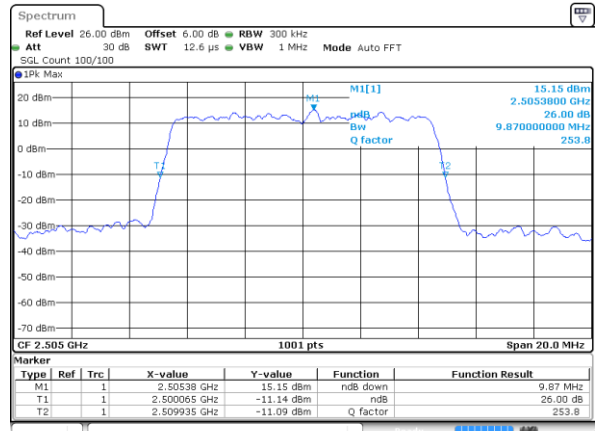

Date: 27 JAN 2020 15:46:17

Middle Channel / 5MHz / 64QAM

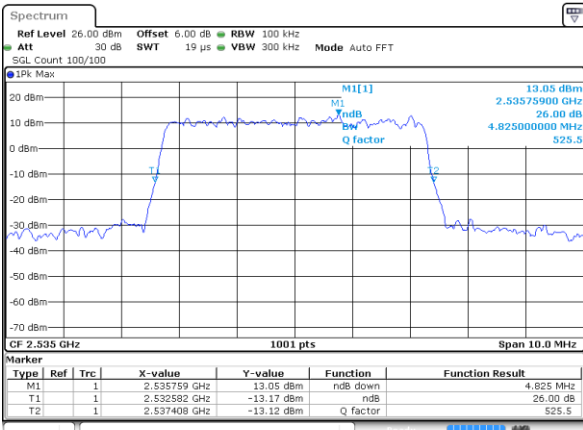

Date: 27 JAN 2020 15:38:10

Middle Channel / 10MHz / 64QAM

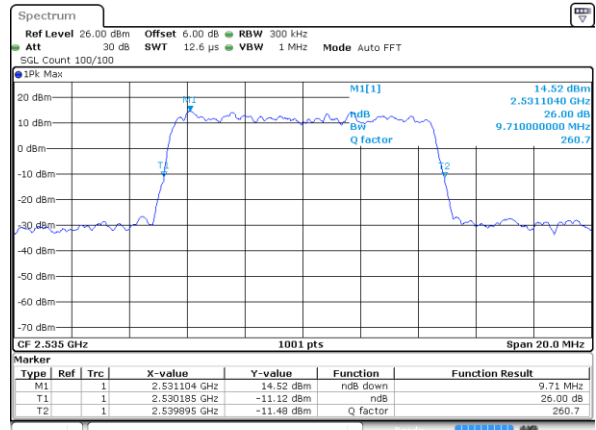

Date: 27 JAN 2020 15:46:28

Highest Channel / 5MHz / 64QAM

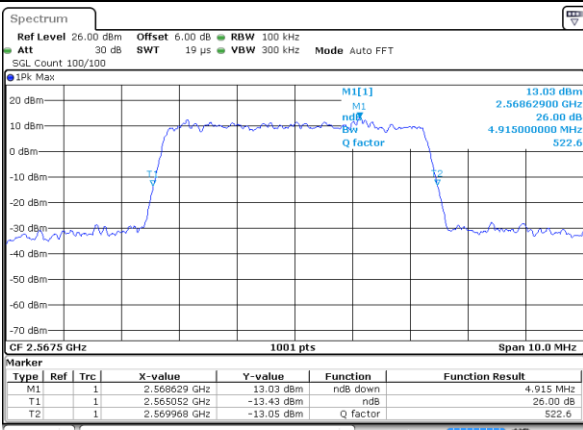

Date: 27 JAN 2020 15:38:21

Highest Channel / 10MHz / 64QAM

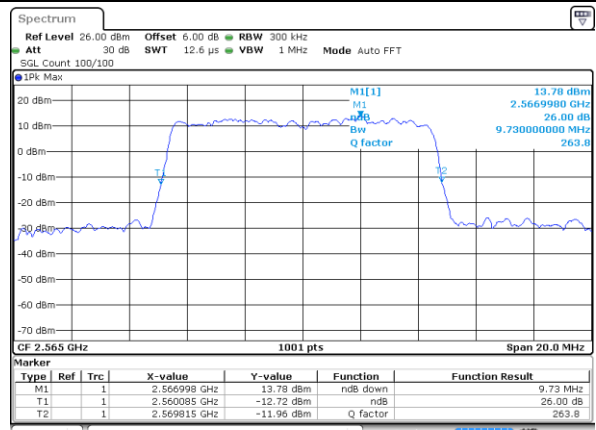

Date: 27 JAN 2020 15:46:38



LTE Band 7

Lowest Channel / 15MHz / 64QAM

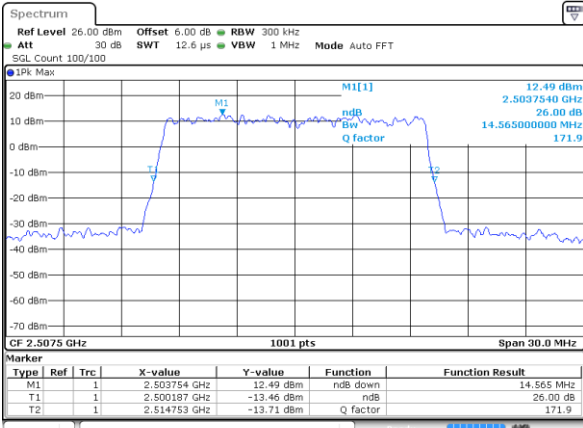

Date: 27 JAN 2020 15:54:34

Lowest Channel / 20MHz / 64QAM

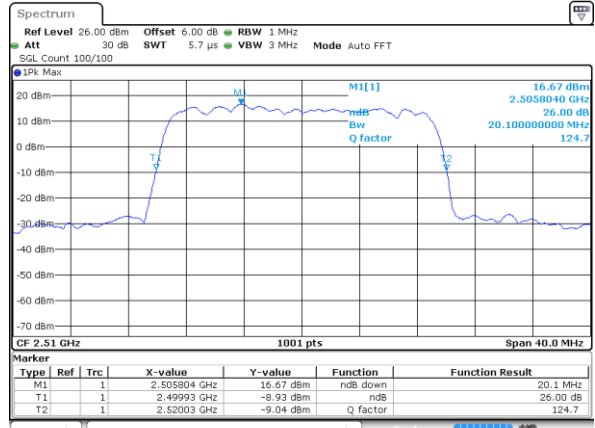

Date: 27 JAN 2020 16:02:51

Middle Channel / 15MHz / 64QAM

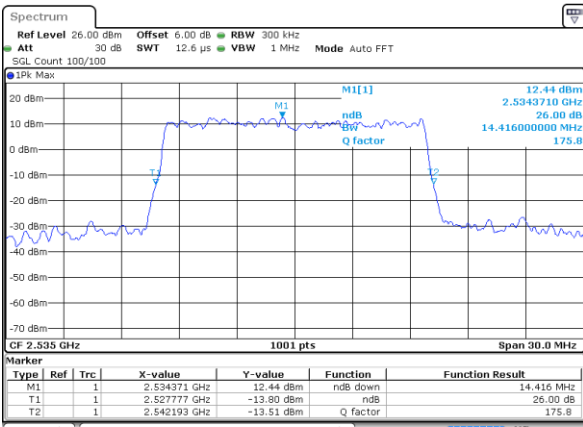

Date: 27 JAN 2020 15:54:44

Middle Channel / 20MHz / 64QAM



Date: 27 JAN 2020 16:03:02

Highest Channel / 15MHz / 64QAM

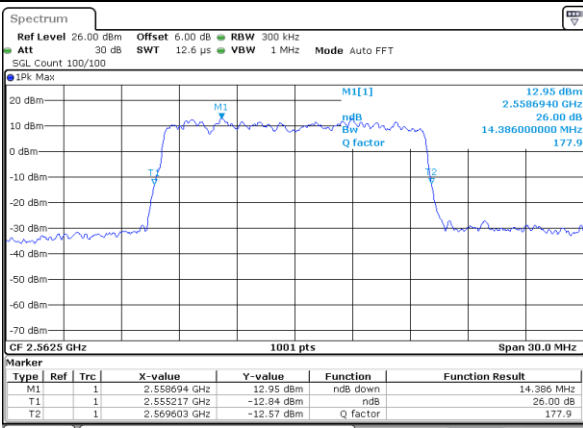

Date: 27 JAN 2020 15:54:54

Highest Channel / 20MHz / 64QAM

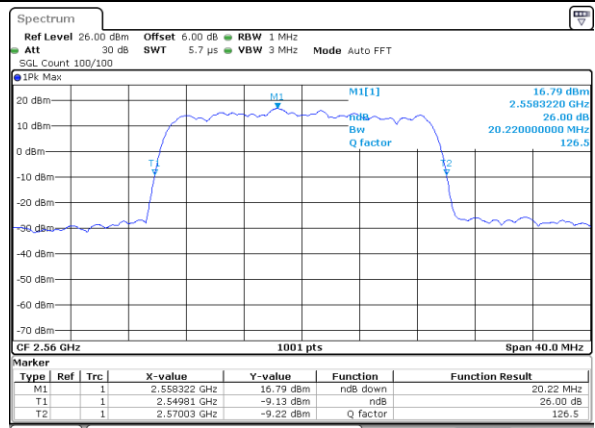

Date: 27 JAN 2020 16:03:12



Occupied Bandwidth

Mode	LTE Band 7 : 99%OBW(MHz)											
BW	1.4MHz		3MHz		5MHz		10MHz		15MHz		20MHz	
Mod.	QPSK	16QAM	QPSK	16QAM	QPSK	16QAM	QPSK	16QAM	QPSK	16QAM	QPSK	16QAM
Lowest CH	-	-	-	-	4.49	4.50	9.13	9.05	13.43	13.37	18.18	18.30
Middle CH	-	-	-	-	4.49	4.50	8.99	9.03	13.43	13.40	18.42	18.22
Highest CH	-	-	-	-	4.51	4.49	9.05	9.01	13.34	13.46	18.30	18.38
Mode	LTE Band 7 : 99%OBW(MHz)											
BW	1.4MHz		3MHz		5MHz		10MHz		15MHz		20MHz	
Mod.	64QAM		64QAM		64QAM		64QAM		64QAM		64QAM	
Lowest CH	-	-	-	-	4.49	-	9.03	-	13.40	-	18.26	-
Middle CH	-	-	-	-	4.50	-	9.05	-	13.49	-	18.30	-
Highest CH	-	-	-	-	4.52	-	9.03	-	13.40	-	18.30	-



LTE Band 7

Lowest Channel / 5MHz / QPSK

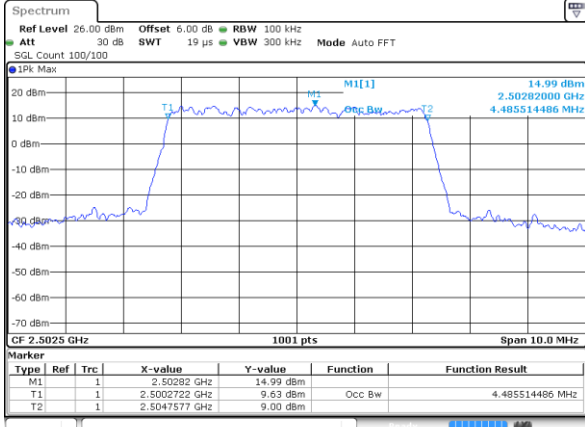

Date: 27 JAN 2020 14:31:14

Lowest Channel / 5MHz / 16QAM

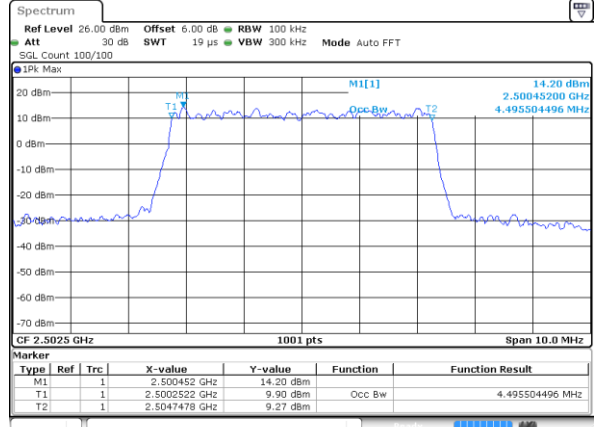

Date: 27 JAN 2020 14:31:34

Middle Channel / 5MHz / QPSK

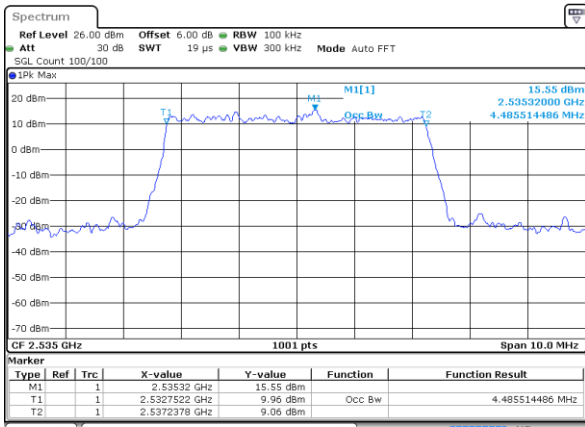

Date: 27 JAN 2020 14:32:15

Middle Channel / 5MHz / 16QAM

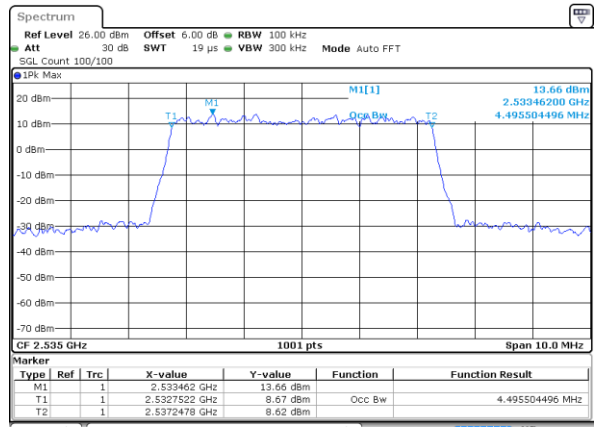

Date: 27 JAN 2020 14:31:54

Highest Channel / 5MHz / QPSK

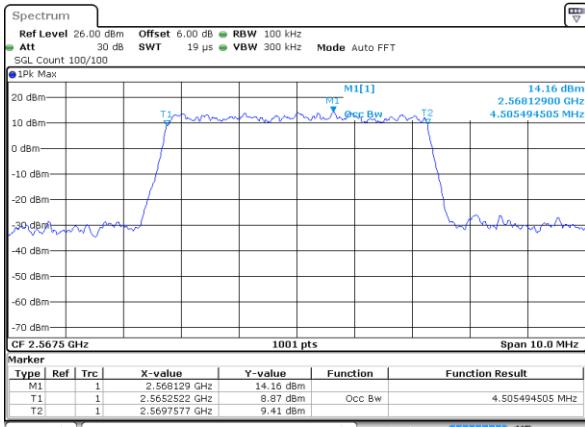

Date: 27 JAN 2020 14:32:35

Highest Channel / 5MHz / 16QAM

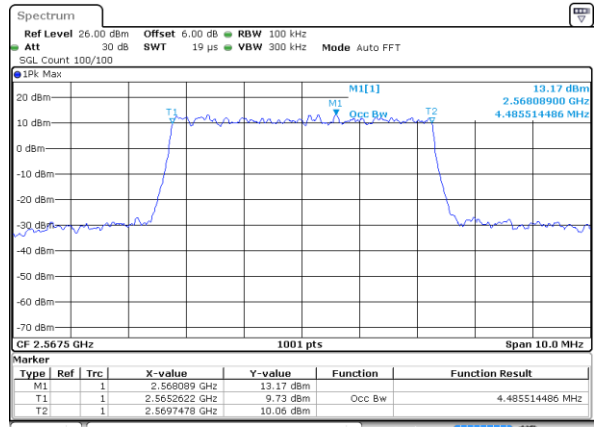

Date: 27 JAN 2020 14:32:55



LTE Band 7

Lowest Channel / 10MHz / QPSK

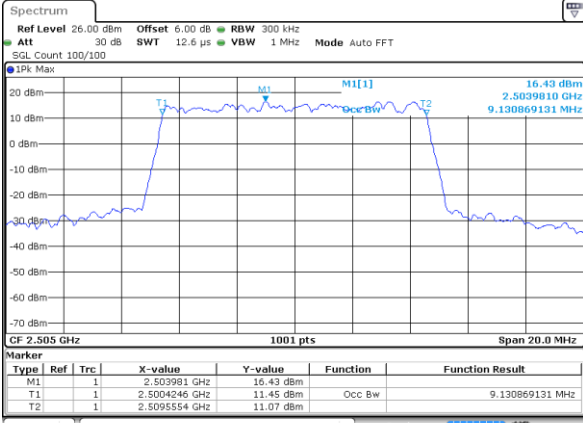

Date: 27 JAN 2020 14:47:48

Lowest Channel / 10MHz / 16QAM

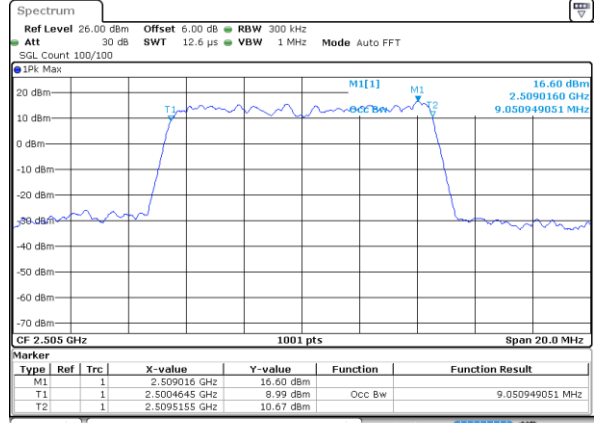

Date: 27 JAN 2020 14:48:08

Middle Channel / 10MHz / QPSK

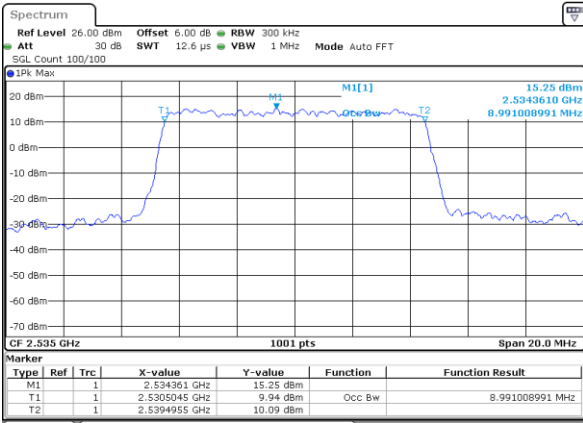

Date: 27 JAN 2020 14:48:49

Middle Channel / 10MHz / 16QAM

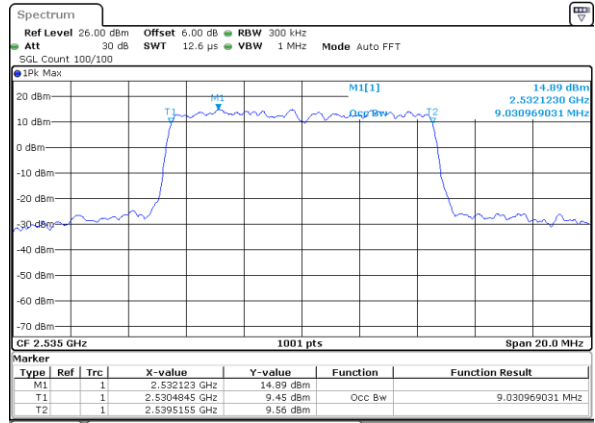

Date: 27 JAN 2020 14:48:29

Highest Channel / 10MHz / QPSK

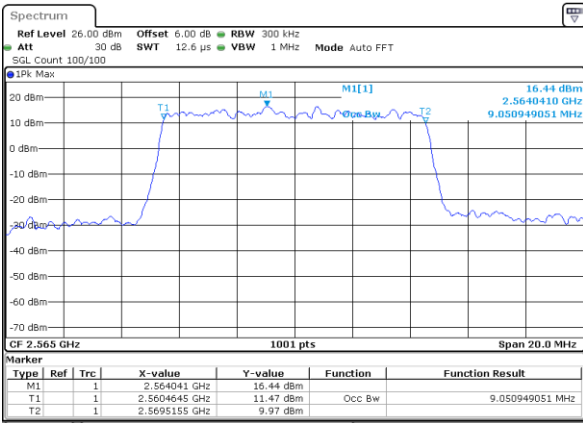

Date: 27 JAN 2020 14:49:10

Highest Channel / 10MHz / 16QAM

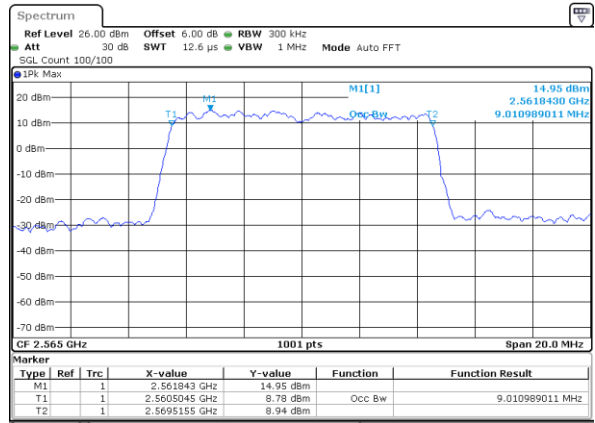

Date: 27 JAN 2020 14:49:30



LTE Band 7

Lowest Channel / 15MHz / QPSK

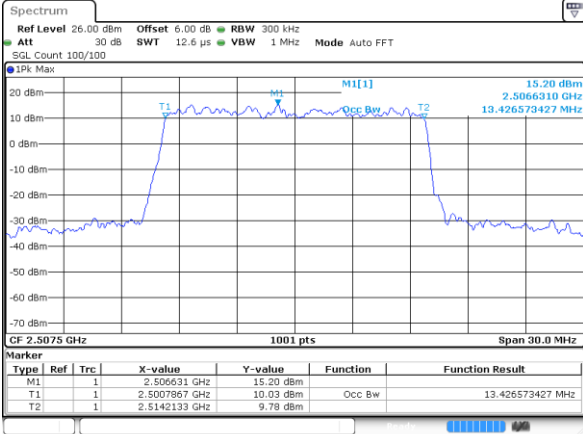

Date: 27 JAN 2020 15:04:41

Lowest Channel / 15MHz / 16QAM

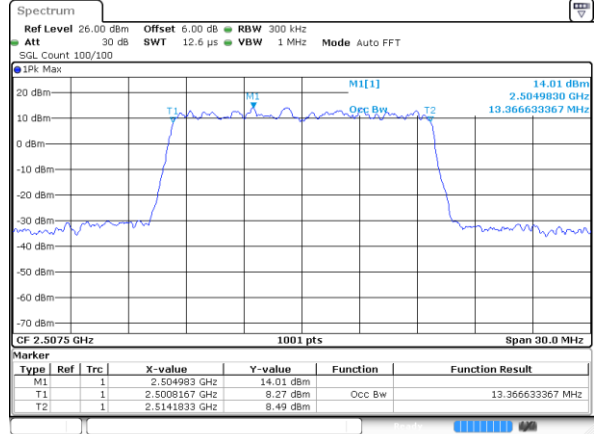

Date: 27 JAN 2020 15:04:21

Middle Channel / 15MHz / QPSK

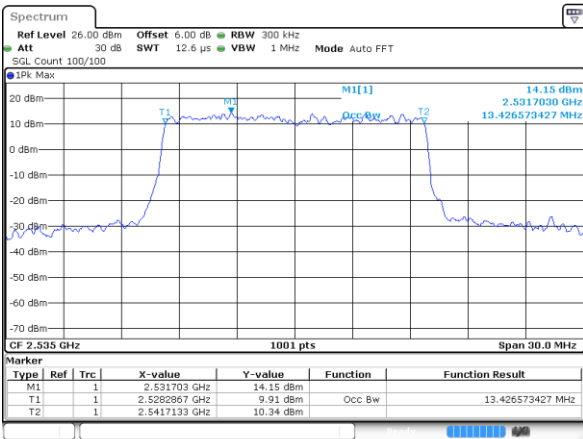

Date: 27 JAN 2020 15:05:02

Middle Channel / 15MHz / 16QAM

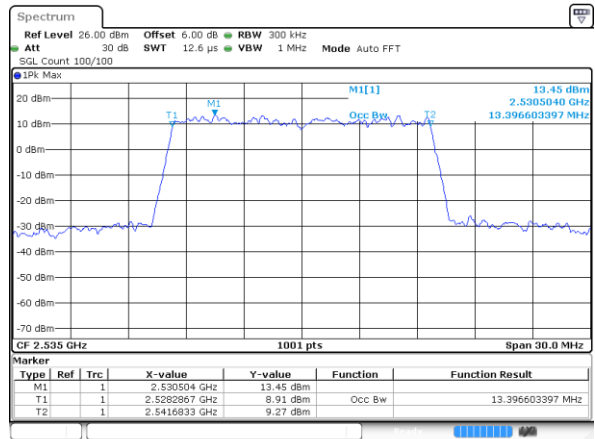

Date: 27 JAN 2020 15:05:22

Highest Channel / 15MHz / QPSK

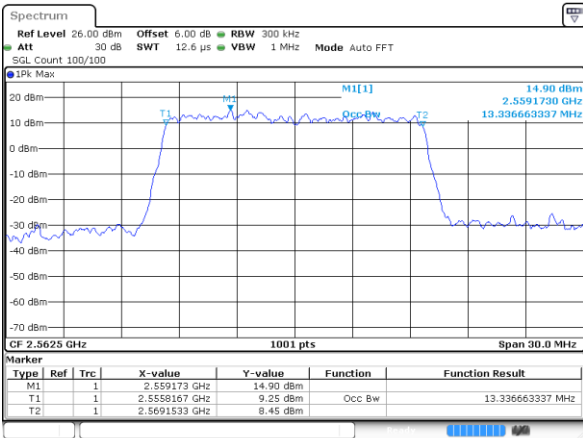

Date: 27 JAN 2020 15:06:03

Highest Channel / 15MHz / 16QAM

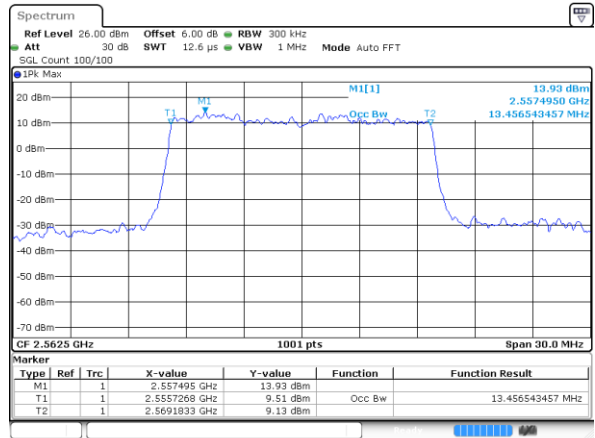

Date: 27 JAN 2020 15:05:42



LTE Band 7

Lowest Channel / 20MHz / QPSK

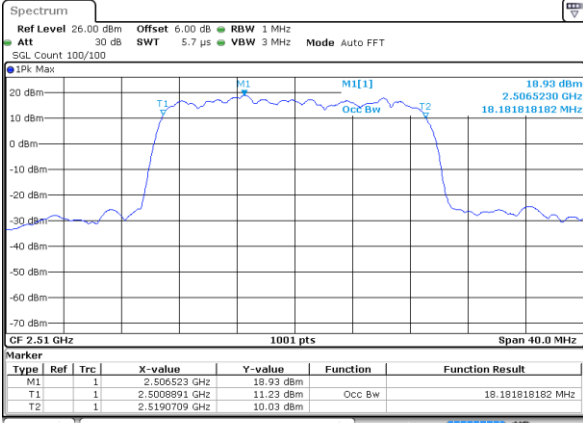

Date: 27 JAN 2020 15:21:16

Lowest Channel / 20MHz / 16QAM

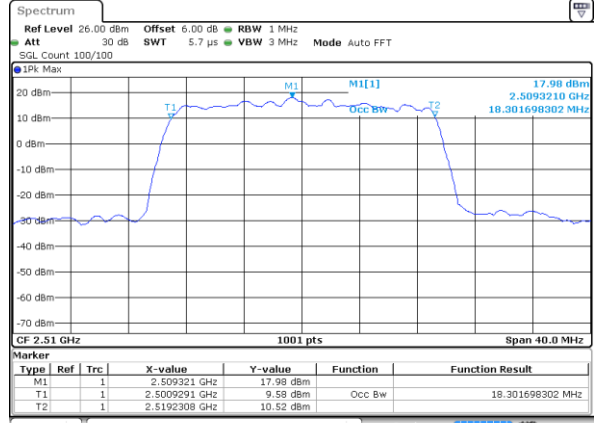

Date: 27 JAN 2020 15:20:55

Middle Channel / 20MHz / QPSK

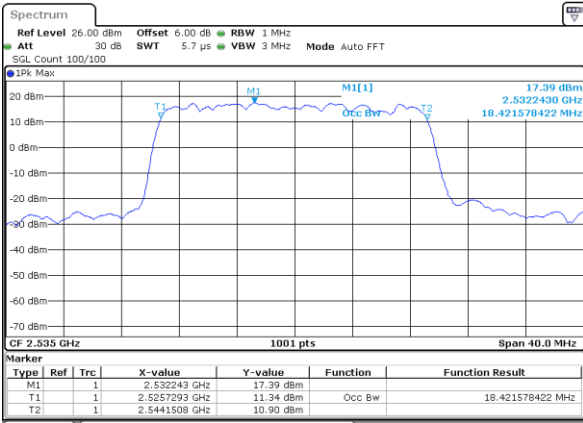

Date: 27 JAN 2020 15:21:36

Middle Channel / 20MHz / 16QAM

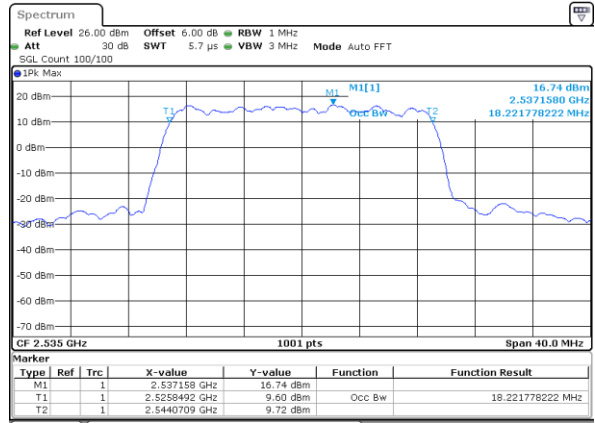

Date: 27 JAN 2020 15:21:56

Highest Channel / 20MHz / QPSK

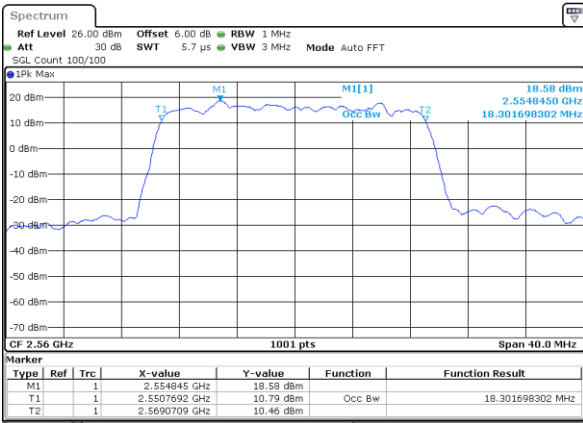

Date: 27 JAN 2020 15:22:37

Highest Channel / 20MHz / 16QAM

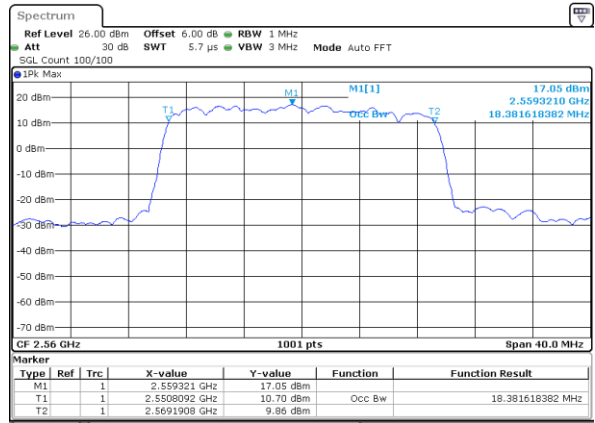

Date: 27 JAN 2020 15:22:17



LTE Band 7

Lowest Channel / 5MHz / 64QAM

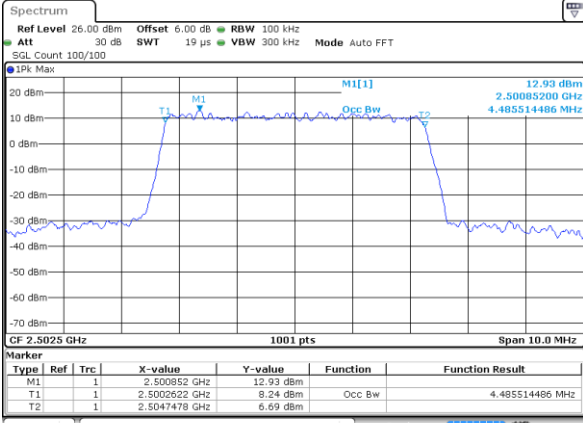

Date: 27 JAN 2020 15:37:30

Lowest Channel / 10MHz / 64QAM

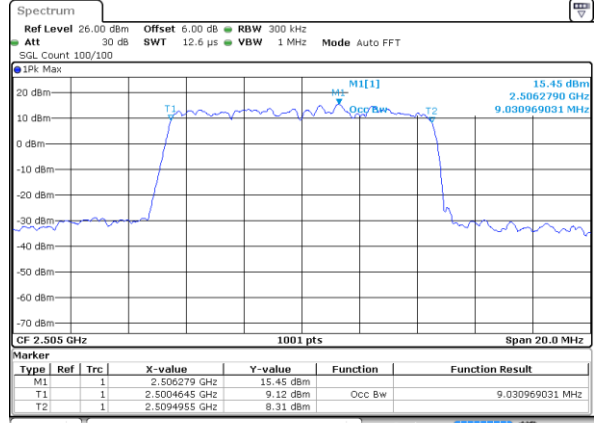

Date: 27 JAN 2020 15:45:47

Middle Channel / 5MHz / 64QAM

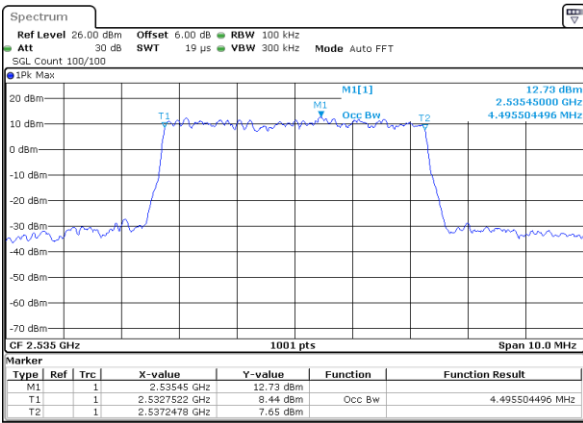

Date: 27 JAN 2020 15:37:40

Middle Channel / 10MHz / 64QAM

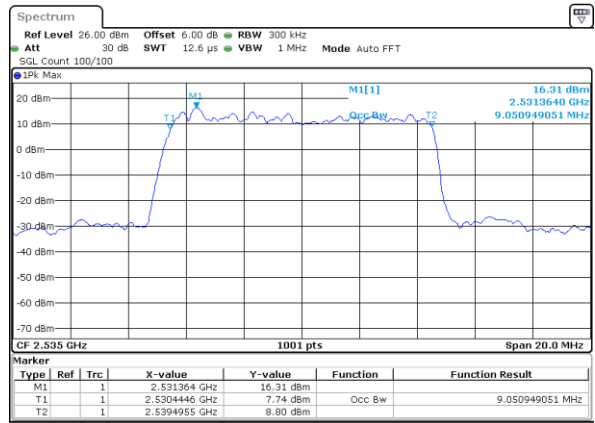

Date: 27 JAN 2020 15:45:57

Highest Channel / 5MHz / 64QAM

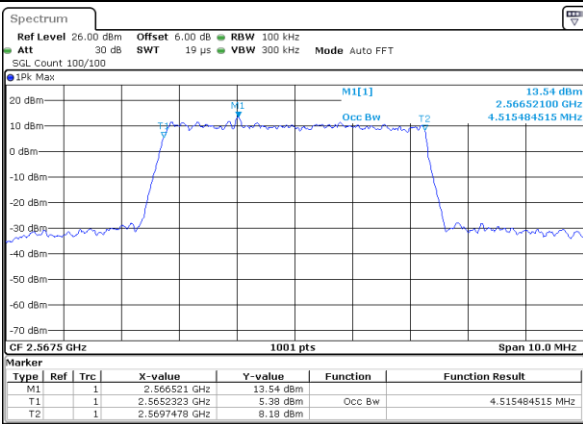

Date: 27 JAN 2020 15:37:50

Highest Channel / 10MHz / 64QAM

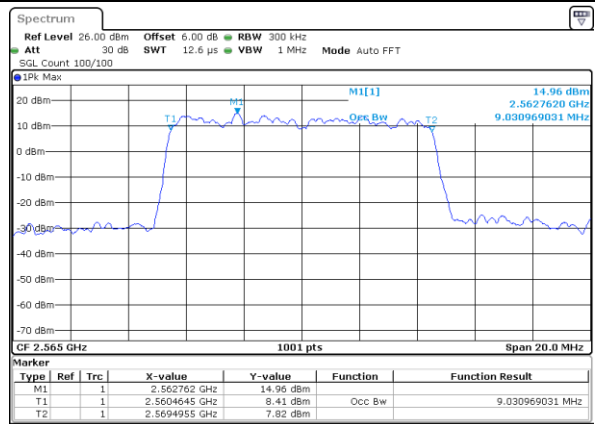

Date: 27 JAN 2020 15:46:07



LTE Band 7

Lowest Channel / 15MHz / 64QAM

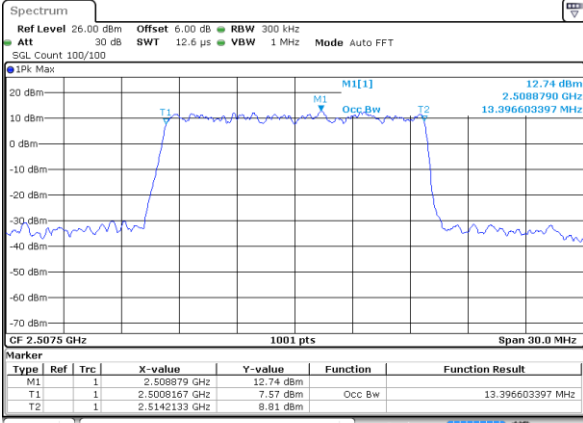

Date: 27 JAN 2020 15:54:03

Lowest Channel / 20MHz / 64QAM

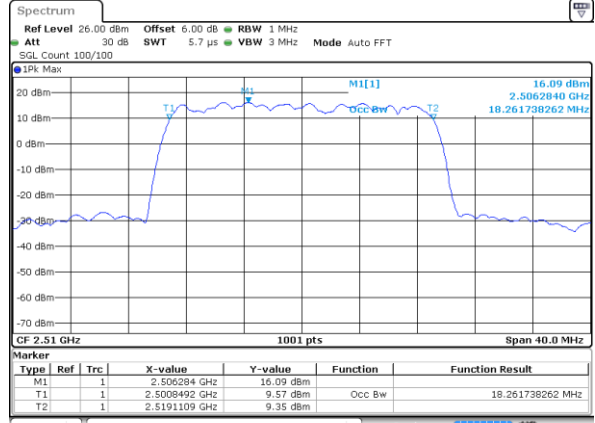

Date: 27 JAN 2020 16:02:21

Middle Channel / 15MHz / 64QAM

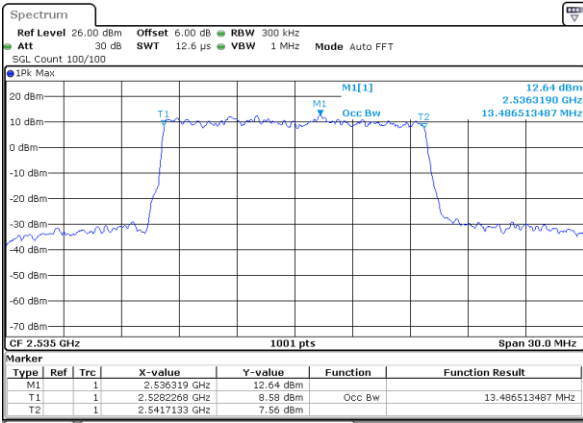

Date: 27 JAN 2020 15:54:14

Middle Channel / 20MHz / 64QAM

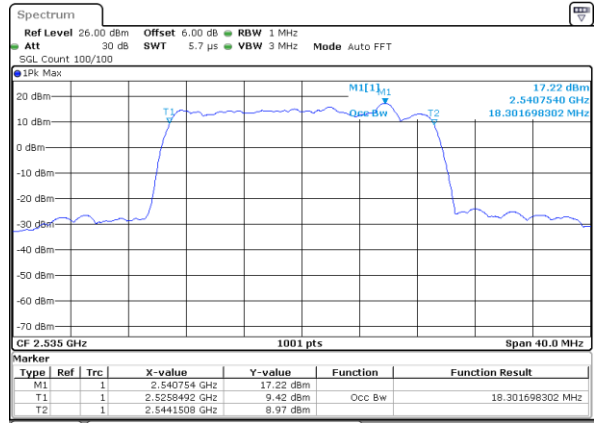

Date: 27 JAN 2020 16:02:31

Highest Channel / 15MHz / 64QAM

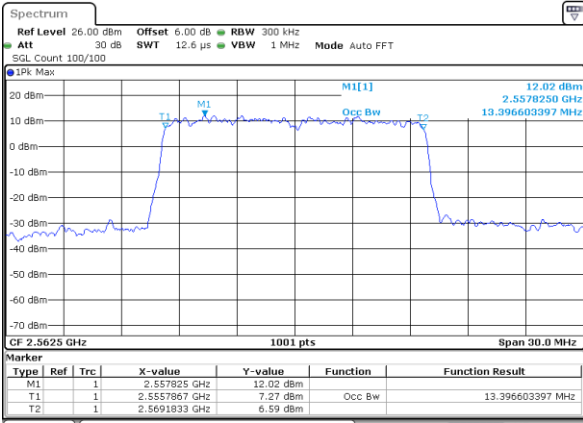

Date: 27 JAN 2020 15:54:24

Highest Channel / 20MHz / 64QAM

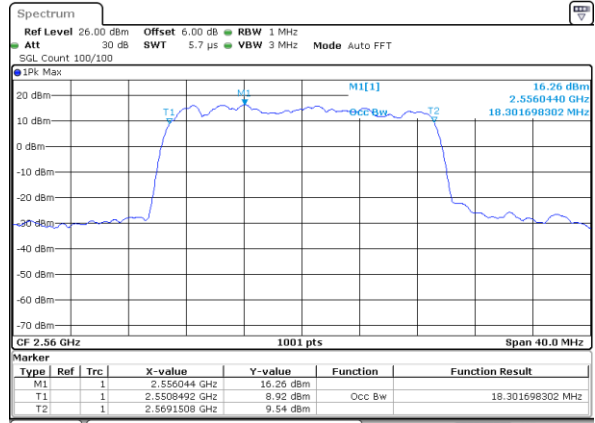

Date: 27 JAN 2020 16:02:41



Conducted Band Edge

LTE Band 7 / 5MHz / QPSK

Lowest Band Edge / 1 RB

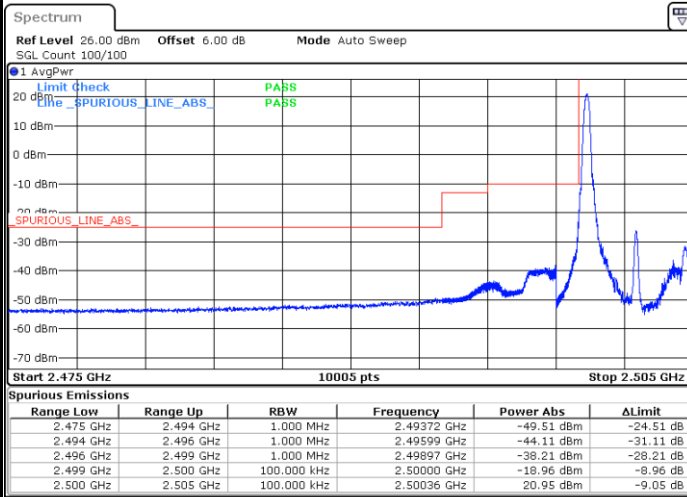

Date: 27 JAN 2020 14:34:14

Highest Band Edge / 1 RB

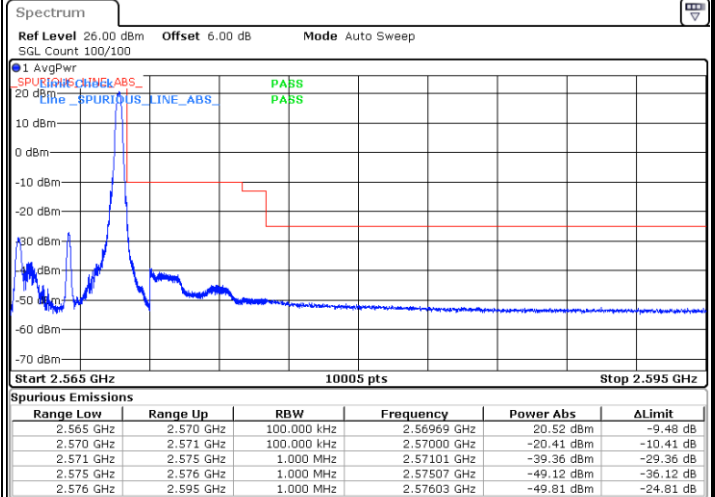

Date: 27 JAN 2020 14:42:14

Lowest Band Edge / Full RB

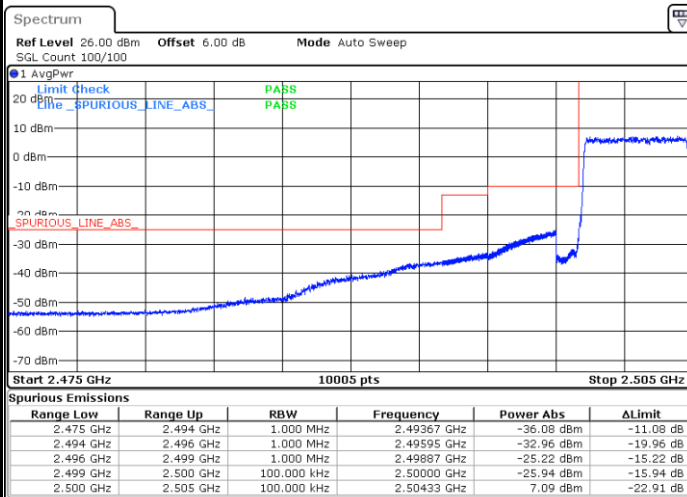

Date: 27 JAN 2020 14:37:41

Highest Band Edge / Full RB

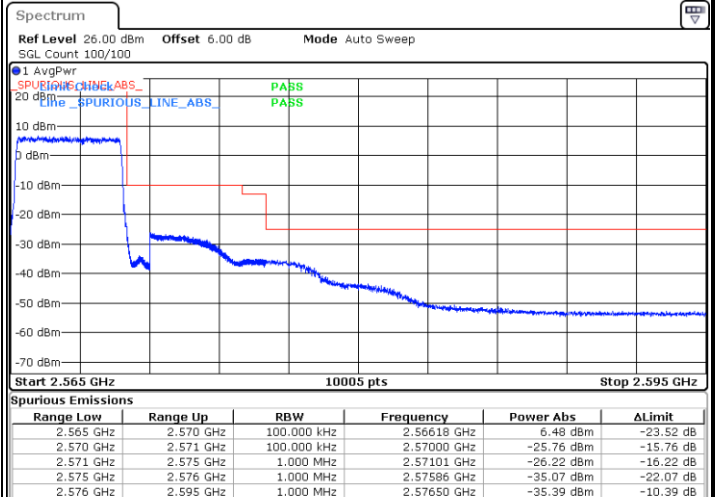

Date: 27 JAN 2020 14:38:49



LTE Band 7 / 5MHz / 16QAM

Lowest Band Edge / 1 RB

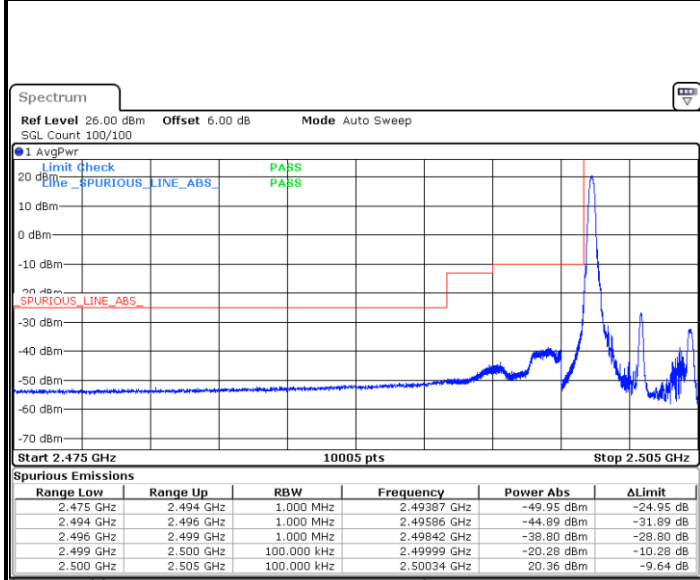

Date: 27.JAN.2020 14:35:23

Highest Band Edge / 1 RB

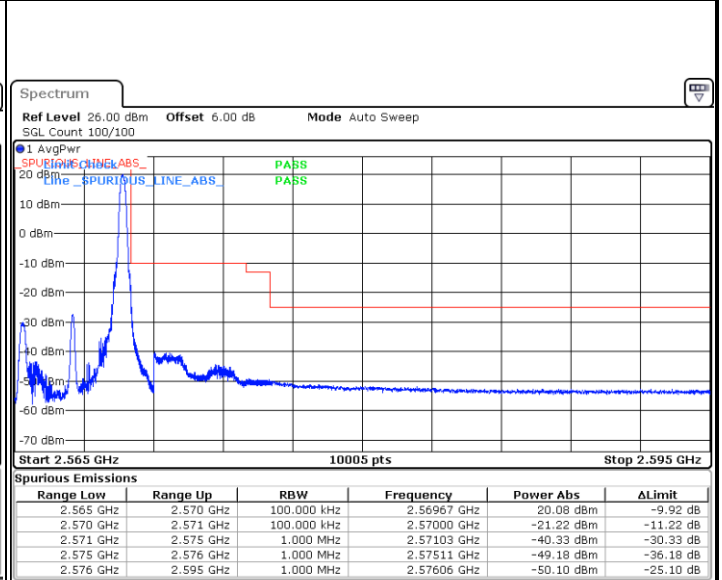

Date: 27.JAN.2020 14:41:06

Lowest Band Edge / Full RB

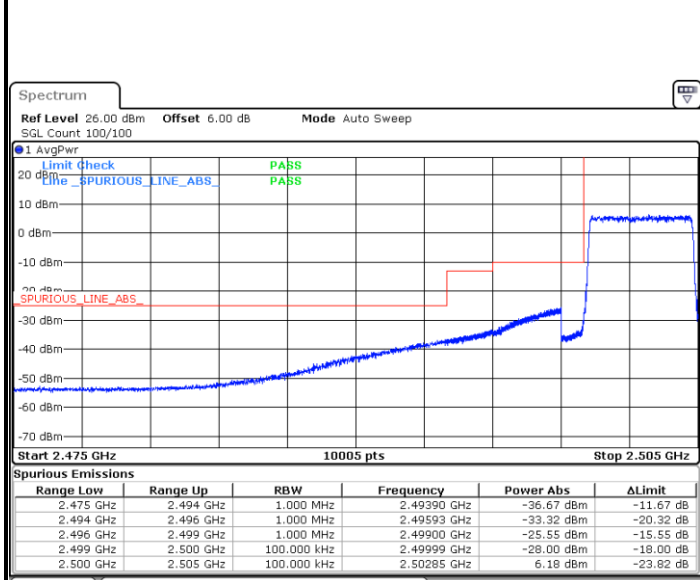

Date: 27.JAN.2020 14:36:32

Highest Band Edge / Full RB

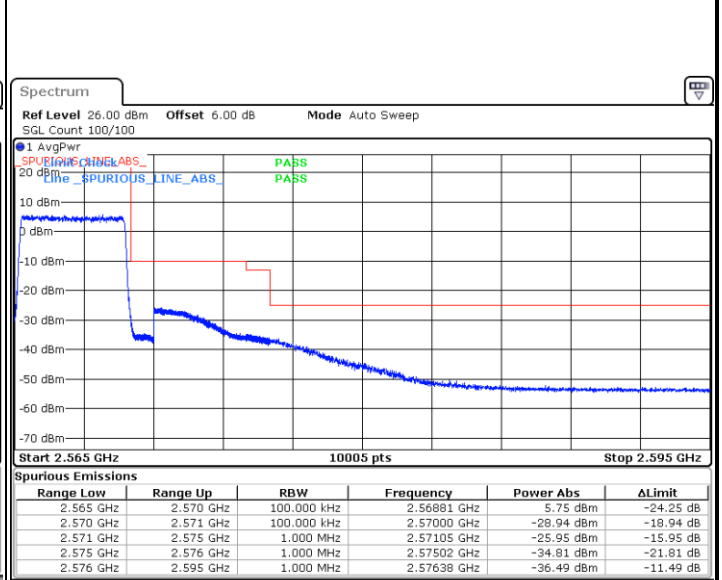

Date: 27.JAN.2020 14:39:57