



FCC RADIO TEST REPORT

FCC ID : IHDT56YJ1
Equipment : Mobile Cellular Phone
Brand Name : Motorola
Model Name : XT2061-1
Applicant : Motorola Mobility, LLC
222 W Merchandise Mart Plaza, Suite
1800, Chicago, IL 60654, United States
Manufacturer : Motorola Mobility, LLC
222 W Merchandise Mart Plaza, Suite
1800, Chicago, IL 60654, United States
Standard : FCC Part 15 Subpart C §15.209

The product was received on Dec. 06, 2019 and testing was started from Mar. 03, 2020 and completed on Mar. 04, 2020. We, SPORTON INTERNATIONAL INC., EMC & Wireless Communications Laboratory, would like to declare that the tested sample has been evaluated in accordance with the test procedures and has been in compliance with the applicable technical standards.

The report must not be used by the client to claim product certification, approval, or endorsement by TAF or any agency of government.

The test results in this report apply exclusively to the tested model / sample. Without written approval of SPORTON INTERNATIONAL INC. EMC & Wireless Communications Laboratory, the test report shall not be reproduced except in full.

Louis Wu

Reviewed by: Louis Wu

SPORTON INTERNATIONAL INC. EMC & Wireless Communications Laboratory
No. 52, Huaya 1st Rd., Guishan Dist., Taoyuan City, Taiwan (R.O.C.)



Table of Contents

History of this test report	3
Summary of Test Result	4
1. General Description	5
1.1 Product Feature of Equipment Under Test	5
1.2 Product Specification of Equipment Under Test	6
1.3 Modification of EUT	6
1.4 Testing Location	7
1.5 Applicable Standards	7
2. Test Configuration of Equipment Under Test.....	8
2.1 Descriptions of Test Mode	8
2.2 Connection Diagram of Test System	8
2.3 Table for Supporting Units	9
2.4 EUT Operation Test Setup	9
3. Test Results	10
3.1 AC Power Line Conducted Emissions Measurement	10
3.2 20dB and 99% OBW Spectrum Bandwidth Measurement	12
3.3 Radiated Emissions Measurement	13
3.4 Antenna Requirements	16
4. List of Measuring Equipment	17
5. Uncertainty of Evaluation.....	19
Appendix A. Test Results of Conducted Emission Test	
Appendix B. Test Results of Conducted Test Items	
B1. Test Result of 20dB Spectrum Bandwidth	
Appendix C. Test Results of Radiated Test Items	
C1. Test Result of Field Strength of Fundamental Emissions	
C2. Results of Radiated Emissions (9 kHz~30MHz)	
C3. Results of Radiated Emissions (30MHz~1GHz)	



History of this test report

Report No.	Version	Description	Issued Date
FR9D0635H	01	Initial issue of report	Mar. 03, 2020



Summary of Test Result

Report Clause	Ref Std. Clause	Test Items	Result (PASS/FAIL)	Remark
3.1	15.207	AC Power Line Conducted Emissions	Pass	Under limit 15.32 dB at 12.930MHz
3.2	15.215(c)	20dB Spectrum Bandwidth	Reporting only	-
	2.1049	99% OBW Spectrum Bandwidth	Reporting only	-
3.3	15.209	Field Strength of Fundamental Emissions	Pass	Max level 38.90 dB μ V/m at 0.140 MHz
		Radiated Spurious Emissions	Pass	Under limit 7.26 dB at 53.280MHz
3.4	15.203	Antenna Requirements	Pass	-

Declaration of Conformity:
The test results with all measurement uncertainty excluded are presented in accordance with the regulation limits or requirements declared by manufacturers.
Comments and Explanations:
The declared of product specification for EUT presented in the report are provided by the manufacturer, and the manufacturer takes all the responsibilities for the accuracy of product specification.

Reviewed by: Wii Chang

Report Producer: Ann Lee



1. General Description

1.1 Product Feature of Equipment Under Test

Product Feature	
Equipment	Mobile Cellular Phone
Brand Name	Motorola
Model Name	XT2061-1
FCC ID	IHDT56YJ1
IMEI Code	Conducted: IMEI : 359120100016412 Radiation: IMEI : 359120100016321 Conduction: IMEI : 359120100016479
EUT supports Radios application	CDMA/EV-DO/GSM/EGPRS/WCDMA/HSPA/LTE/5G NR/ GNSS/NFC/WPC WLAN 11b/g/n HT20 WLAN 11a/n HT20/HT40 WLAN 11ac VHT20/VHT40/VHT80 WLAN 11ax HE20/HE40/HE80 Bluetooth BR/EDR/LE
HW Version	DVT2
EUT Stage	Identical Prototype

Remark: The above EUT's information was declared by manufacturer.

Accessory List	
AC Adapter 1	Brand Name : Motorola
	Model Name : SC-51 (SA18C30116)
	Manufacturer : Chenyang
AC Adapter 2	Brand Name : Motorola
	Model Name : SC-51 (SA18C62985)
	Manufacturer : Acbel
Battery	Brand Name : ATL
	Model Name : LW50
USB Cable 1	Brand Name : Motorola
	Model Name : SC18C24367
USB Cable 2	Brand Name : Motorola
	Model Name : SC18C24368



1.2 Product Specification of Equipment Under Test

Standards-related Product Specification	
Tx/Rx Frequency	100~300kHz
20dBW	0.774 kHz
99%OBW	0.654 kHz
Antenna Type	flex pattern antenna

Remark: The above EUT's information was declared by manufacturer.

1.3 Modification of EUT

No modifications are made to the EUT during all test items.



1.4 Testing Location

Test Site	SPORTON INTERNATIONAL INC. EMC & Wireless Communications Laboratory	
Test Site Location	No.52, Huaya 1st Rd., Guishan Dist., Taoyuan City, Taiwan (R.O.C.) TEL: +886-3-327-3456 FAX: +886-3-328-4978	
Test Site No.	Sporton Site No.	
	TH03-HY	CO05-HY
Test Engineer	Louis Chung	Tom Lee
Temperature	22-24°C	21-24°C
Relative Humidity	53-55%	42~45%

Note: The test site complies with ANSI C63.4 2014 requirement.

Test Site	SPORTON INTERNATIONAL INC. EMC & Wireless Communications Laboratory	
Test Site Location	No.58, Aly. 75, Ln. 564, Wenhua 3rd, Rd., Guishan Dist., Taoyuan City, Taiwan (R.O.C.) TEL: +886-3-327-0868 FAX: +886-3-327-0855	
Test Site No.	Sporton Site No.	
	03CH11-HY	
Test Engineer	Fu Chen, Cookie Ku, and Troye Hsieh	
Temperature	20.1~26.5°C	
Relative Humidity	44.1~68.9%	

Note: The test site complies with ANSI C63.4 2014 requirement.

FCC designation No.: TW1190 and TW0007

1.5 Applicable Standards

According to the specifications of the manufacturer, the EUT must comply with the requirements of the following standards:

- ♦ FCC Part 15 Subpart C §15.209
- ♦ FCC KDB 414788 D01 Radiated Test Site v01r01
- ♦ ANSI C63.10-2013

2. Test Configuration of Equipment Under Test

2.1 Descriptions of Test Mode

Investigation has been done on all the possible configurations.

The following table is a list of the test modes shown in this test report.

Test Items	
AC Power Line Conducted Emissions	20dB Spectrum Bandwidth
Field Strength of Fundamental Emissions	
Radiated Emissions 9kHz~30MHz	Radiated Emissions 30MHz~1GHz

Pre-scanned tests, X, Y, Z in three orthogonal panels to determine the final configuration (X plane as worst plane) from all possible combinations.

Test Cases	
AC Conducted Emission	Mode 1 : WPT Charging with Mobile Phone + Earphone + USB Cable (Charging from Adapter 1)
Remark: For Radiated Test Cases, the tests were performed with Adapter 1 and USB Cable 1	

2.2 Connection Diagram of Test System

<AC Conducted Emission Mode>

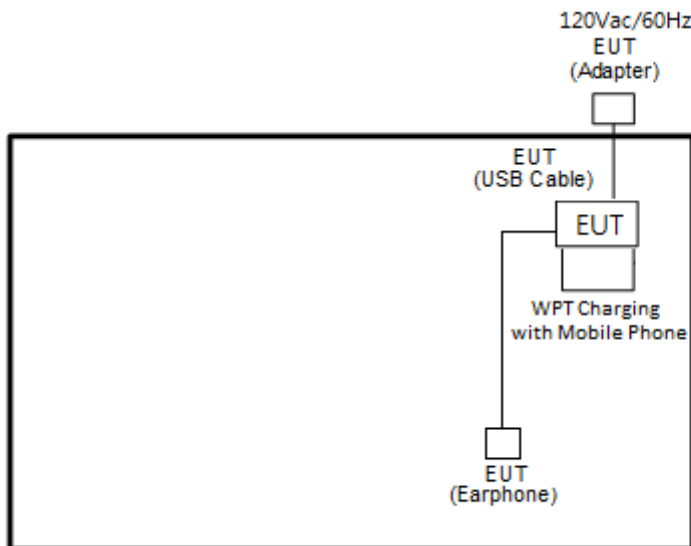

<WPT Tx Mode>

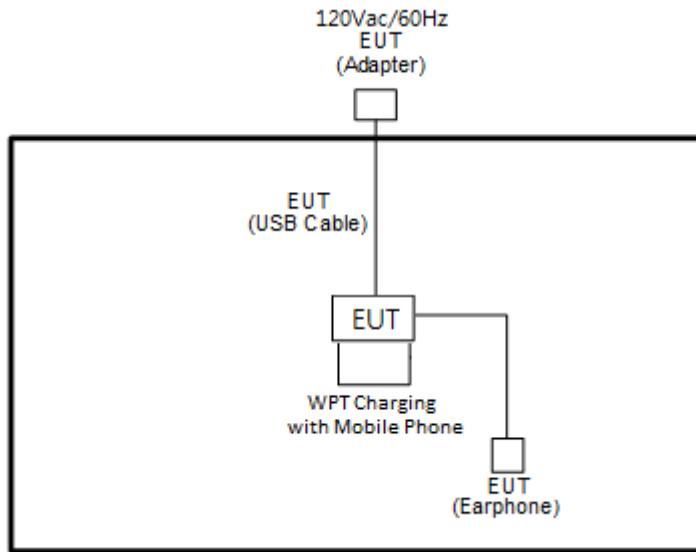

2.3 Table for Supporting Units

Item	Equipment	Trade Name	Model Name	FCC ID	Data Cable	Power Cord
1.	Mobile Phone	Moto	moto burton	N/A	N/A	N/A

2.4 EUT Operation Test Setup

The EUT was programmed to be in continuously transmitting mode.



3. Test Results

3.1 AC Power Line Conducted Emissions Measurement

3.1.1 Limit of AC Conducted Emission

For equipment that is designed to be connected to the public utility (AC) power line, the radio frequency voltage that is conducted back onto the AC power line on any frequency or frequencies within the band 150 kHz to 30 MHz shall not exceed the limits in the following table.

Frequency of Emission (MHz)	Conducted Limit (dBµV)	
	Quasi-Peak	Average
0.15-0.5	66 to 56*	56 to 46*
0.5-5	56	46
5-30	60	50

*Decreases with the logarithm of the frequency.

3.1.2 Measuring Instruments

See list of measuring equipment of this test report.

3.1.3 Test Procedures

1. The EUT was placed 0.4 meter from the conducting wall of the shielding room, and it was kept at least 80 centimeters from any other grounded conducting surface.
2. Connect EUT to the power mains through a line impedance stabilization network (LISN).
3. All the support units are connecting to the other LISN.
4. The LISN provides 50 ohm coupling impedance for the measuring instrument.
5. The FCC states that a 50 ohm, 50 microhenry LISN should be used.
6. Both sides of AC line were checked for maximum conducted interference.
7. The frequency range from 150 kHz to 30 MHz was searched.
8. Set the test-receiver system to Peak Detect Function and specified bandwidth (IF Bandwidth = 9kHz) with Maximum Hold Mode. Then measurement is also conducted by Average Detector and Quasi-Peak Detector Function respectively.

3.1.4 Test setup

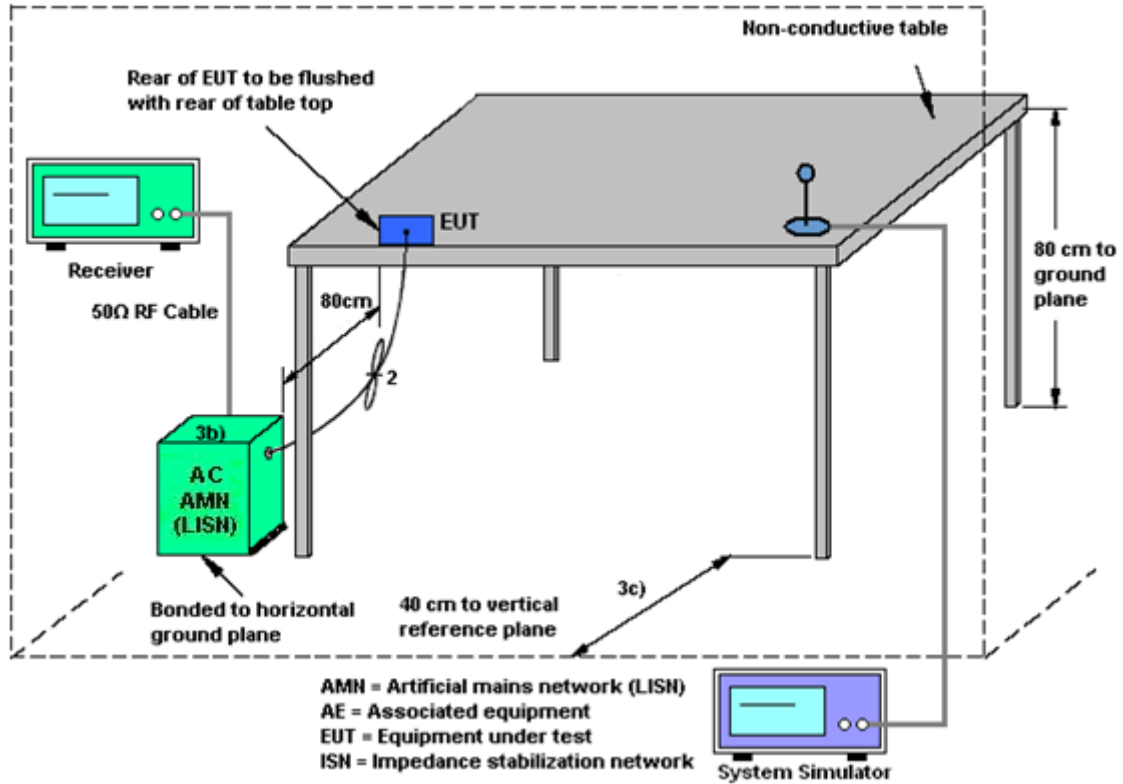

3.1.5 Test Result of AC Conducted Emission

Please refer to Appendix A.

3.2 20dB and 99% OBW Spectrum Bandwidth Measurement

3.2.1 Limit

Reporting only

3.2.2 Measuring Instruments

See list of measuring instruments of this test report.

3.2.3 Test Procedures

1. The spectrum analyzer connected via a receive antenna placed near the EUT in peak Max hold mode.
2. The resolution bandwidth of 1 kHz and the video bandwidth of 3 kHz were used.
3. Measured the spectrum width with power higher than 20dB below carrier.
4. Measured the 99% OBW.

3.2.4 Test Setup

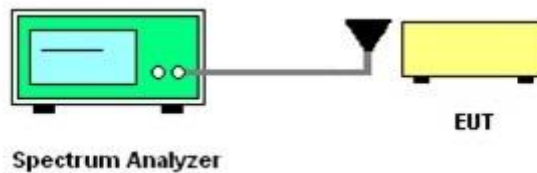

3.2.5 Test Result of Conducted Test Items

Please refer to Appendix B.

3.3 Radiated Emissions Measurement

3.3.1 Limit

The field strength of any emissions which appear band shall not exceed the general radiated emissions limits.

Frequencies (MHz)	Field Strength (μ V/m)	Measurement Distance (meters)
0.009~0.490	2400/F(kHz)	300
0.490~1.705	24000/F(kHz)	30
1.705~30.0	30	30
30~88	100	3
88~216	150	3
216~960	200	3
Above 960	500	3

3.3.2 Measuring Instruments

See list of measuring instruments of this test report.

3.3.3 Measuring Instrument Setting

The following table is the setting of receiver:

Receiver Parameter	Setting
Attenuation	Auto
Frequency Range: 9kHz~150kHz	RBW 200Hz for QP
Frequency Range: 150kHz~30MHz	RBW 9kHz for QP
Frequency Range: 30MHz~1000MHz	RBW 120kHz for Peak

Note: The emission limits shown in the above table are based on measurements employing a CISPR quasi-peak detector except for the frequency bands 9-90 kHz and 110-490 kHz. Radiated emission limits in these two bands are based on measurements employing an average detector.



3.3.4 Test Procedures

1. Configure the EUT according to ANSI C63.10. The EUT was placed on the top of the turntable 0.8 meter above ground. The phase center of the receiving antenna mounted on the top of a height-variable antenna tower was placed 3 meters far away from the turntable.
2. Power on the EUT and all the supporting units. The turntable was rotated by 360 degrees to determine the position of the highest radiation.
3. The height of the broadband receiving antenna was varied between one meter and four meters above ground to find the maximum emissions field strength of both horizontal and vertical polarization.
4. For each suspected emissions, the antenna tower was scan (from 1 M to 4 M) and then the turntable was rotated (from 0 degree to 360 degrees) to find the maximum reading.
5. Set the test-receiver system to Peak or CISPR quasi-peak Detect Function with specified bandwidth under Maximum Hold Mode.
6. When the radiated emissions limits are expressed in terms of the average value of the emissions, and pulsed operation is employed, the measurement field strength shall be determined by averaging over one complete pulse train, including blanking intervals, as long as the pulse train does not exceed 0.1 seconds. As an alternative (provided the transmitter operates for longer than 0.1 seconds) or in cases where the pulse train exceeds 0.1 seconds, the measured field strength shall be determined from the average absolute voltage during a 0.1 second interval during which the field strength is at its maximum value.
7. In case the emission is lower than 30MHz, loop antenna has to be used for measurement and the recorded data should be QP measured by receiver.

3.3.5 Test Setup

For radiated emissions below 30MHz

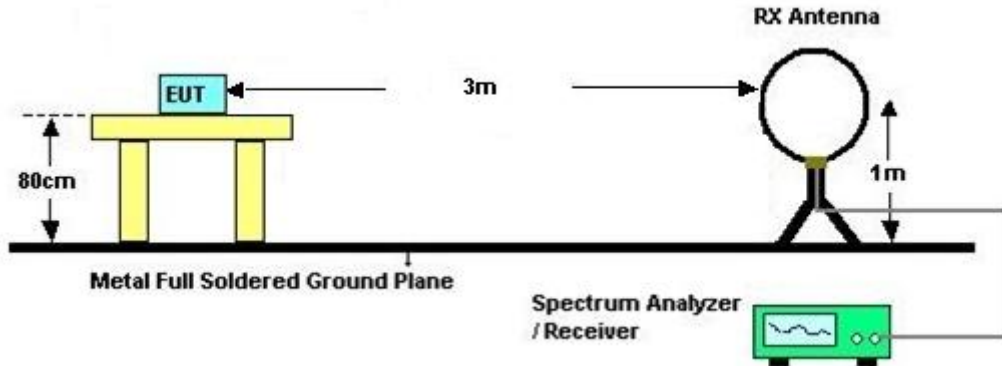

For radiated emissions above 30MHz

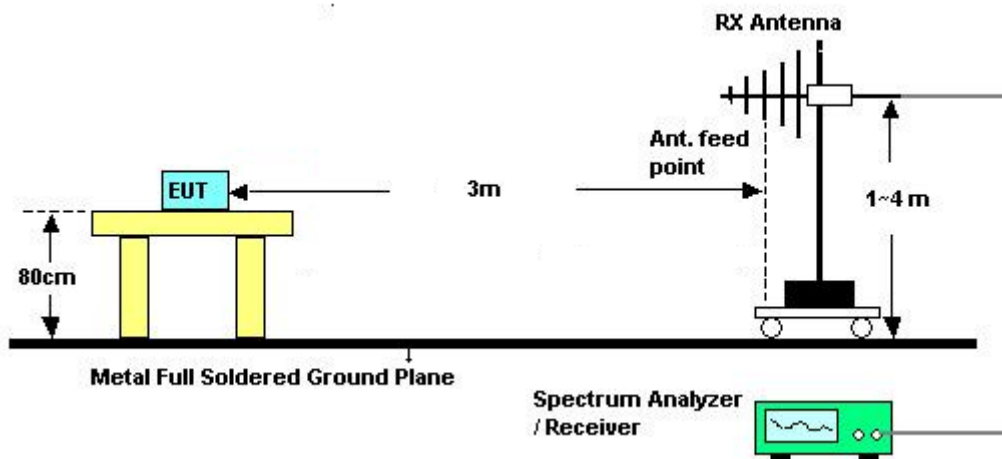

3.3.6 Test Result of Radiated Emissions Measurement

Please refer to Appendix C.



3.4 Antenna Requirements

3.4.1 Standard Applicable

Except for special regulations, the Low-power Radio-frequency Devices must not be equipped with any jacket for installing an antenna with extension cable. An intentional radiator shall be designed to ensure that no antenna other than that furnished by the responsible party shall be used with the device. The use of a permanently attached antenna or of an antenna that uses a unique coupling to the intentional radiator shall be considered sufficient to comply with the provisions of this Section. The manufacturer may design the unit so that the user can replace a broken antenna, but the use of a standard antenna jack or electrical connector is prohibited.

The use of a permanently attached antenna or of an antenna that uses a unique coupling to the intentional radiator shall be considered sufficient to comply with the rule.

3.4.2 Antenna Anti-Replacement Construction

An embedded-in antenna design is used.



4. List of Measuring Equipment

Instrument	Manufacturer	Model No.	Serial No.	Characteristics	Calibration Date	Test Date	Due Date	Remark
Hygrometer	Testo	608-H1	34893241	N/A	Mar. 06, 2019	Mar. 04, 2020	Mar. 05, 2020	Conducted (TH03-HY)
Spectrum Analyzer	Rohde & Schwarz	FSP30	101329	9kHz~30GHz	Sep. 04, 2019	Mar. 04, 2020	Sep. 03, 2020	Conducted (TH03-HY)
AC Power Source	ChainTek	APC-1000W	N/A	N/A	N/A	Mar. 04, 2020	N/A	Conduction (CO05-HY)
EMI Test Receiver	Rohde & Schwarz	ESR3	102388	9kHz~3.6GHz	Nov. 15, 2019	Mar. 04, 2020	Nov. 14, 2020	Conduction (CO05-HY)
Hygrometer	Testo	608-H1	34913912	N/A	Mar. 19, 2019	Mar. 04, 2020	Mar. 18, 2020	Conduction (CO05-HY)
LISN	Rohde & Schwarz	ENV216	100081	9kHz~30MHz	Nov. 15, 2019	Mar. 04, 2020	Nov. 14, 2020	Conduction (CO05-HY)
Software	Rohde & Schwarz	EMC32 V10.30	N/A	N/A	N/A	Mar. 04, 2020	N/A	Conduction (CO05-HY)
LF Cable	HUBER + SUHNER	RG-214/U	LF01	N/A	Jan. 02, 2020	Mar. 04, 2020	Jan. 01, 2021	Conduction (CO05-HY)
Pulse Limiter	Rohde & Schwarz	ESH3-Z2	100851	N/A	Jan. 02, 2020	Mar. 04, 2020	Jan. 01, 2021	Conduction (CO05-HY)



Instrument	Manufacturer	Model No.	Serial No.	Characteristics	Calibration Date	Test Date	Due Date	Remark
Software	Audix	E3 6.2009-8-24	RK-00105 3	N/A	N/A	Mar. 04, 2020	N/A	Radiation (03CH11-HY)
Amplifier	SONOMA	310N	187312	9kHz~1GHz	Dec. 03, 2019	Mar. 04, 2020	Dec. 02, 2020	Radiation (03CH11-HY)
Bilog Antenna	TESEQ	CBL 6111D & N-6-06	35414 & AT-N0602	30MHz~1GHz	Oct. 12, 2019	Mar. 04, 2020	Oct. 11, 2020	Radiation (03CH11-HY)
Loop Antenna	Rohde & Schwarz	HFH2-Z2	100488	9 kHz~30 MHz	Jan. 09, 2020	Mar. 04, 2020	Jan. 08, 2021	Radiation (03CH11-HY)
Controller	EMEC	EM 1000	N/A	Control Turn table & Ant Mast	N/A	Mar. 04, 2020	N/A	Radiation (03CH11-HY)
Antenna Mast	EMEC	AM-BS-4500- B	N/A	1~4m	N/A	Mar. 04, 2020	N/A	Radiation (03CH11-HY)
Turn Table	EMEC	TT 2000	N/A	0~360 Degree	N/A	Mar. 04, 2020	N/A	Radiation (03CH11-HY)
EMI Test Receiver	Agilent	N9038A(MXE)	MY554201 70	20MHz~8.4GHz	Mar. 08, 2019	Mar. 04, 2020	Mar. 07, 2020	Radiation (03CH11-HY)
Spectrum Analyzer	Keysight	N9010A	MY542004 86	10Hz~44GHz	Oct. 28, 2019	Mar. 04, 2020	Oct. 27, 2020	Radiation (03CH11-HY)
Filter	Wainwright	WHK20/1000 C7/40SS	SN2	20M High Pass	Sep. 15, 2019	Mar. 04, 2020	Sep. 14, 2020	Radiation (03CH11-HY)
RF Cable	HUBER + SUHNER	SUCOFLEX 104	MY9837/4 PE	9kHz-30MHz	Mar. 13, 2019	Mar. 04, 2020	Mar. 12, 2020	Radiation (03CH11-HY)
RF Cable	HUBER + SUHNER	SUCOFLEX 104	MY9837/4 PE	30M-18G	Mar. 13, 2019	Mar. 04, 2020	Mar. 12, 2020	Radiation (03CH11-HY)
RF Cable	HUBER + SUHNER	SUCOFLEX 102	MY2859/2	30MHz-40GHz	Mar. 13, 2019	Mar. 04, 2020	Mar. 12, 2020	Radiation (03CH11-HY)
Hygrometer	TECPEL	DTN-303B	TP140325	N/A	Nov. 07, 2019	Mar. 04, 2020	Nov. 06, 2020	Radiation (03CH11-HY)
Hygrometer	TECPEL	DTN-303B	TP161237	N/A	Oct. 25, 2019	Mar. 04, 2020	Oct. 24, 2020	Radiation (03CH11-HY)



5. Uncertainty of Evaluation

Uncertainty of Conducted Emission Measurement (150 kHz ~ 30 MHz)

Measuring Uncertainty for a Level of Confidence of 95% ($U = 2Uc(y)$)	2.00
---	------

Uncertainty of Radiated Emission Measurement (9 kHz ~ 30 MHz)

Measuring Uncertainty for a Level of Confidence of 95% ($U = 2Uc(y)$)	3.12
---	------

Uncertainty of Radiated Emission Measurement (30 MHz ~ 1000 MHz)

Measuring Uncertainty for a Level of Confidence of 95% ($U = 2Uc(y)$)	5.20
---	------



Appendix A. Test Results of Conducted Emission Test

Test Engineer :	Tom Lee	Temperature :	21~24°C
		Relative Humidity :	42~45%

EUT Information

Report NO : 9D0635
 Test Mode : Mode 1
 Test Voltage : 120Vac/60Hz
 Phase : Line

Full Spectrum

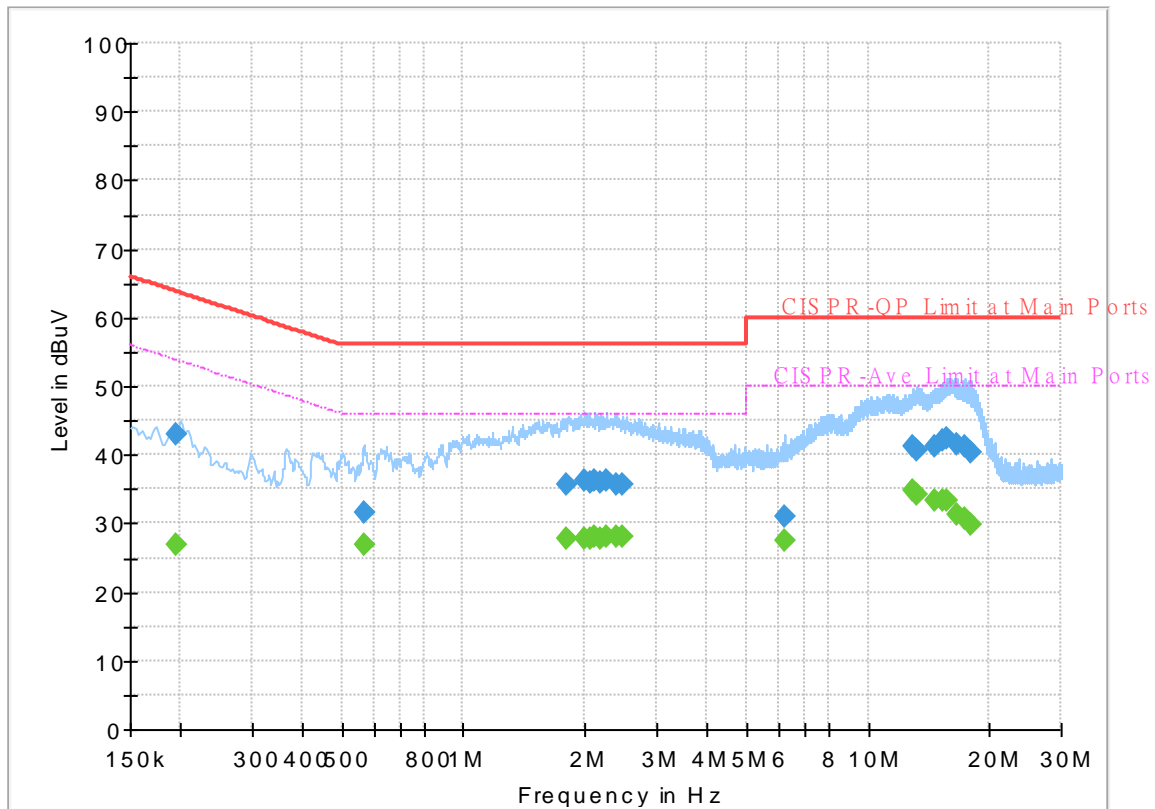

Final_Result

Frequency (MHz)	QuasiPeak (dBuV)	CAverage (dBuV)	Limit (dBuV)	Margin (dB)	Line	Filter	Corr. (dB)
0.195000	---	26.98	53.82	26.84	L1	OFF	19.5
0.195000	42.94	---	63.82	20.88	L1	OFF	19.5
0.566070	---	26.82	46.00	19.18	L1	OFF	19.5
0.566070	31.64	---	56.00	24.36	L1	OFF	19.5
1.806000	---	27.71	46.00	18.29	L1	OFF	19.6
1.806000	35.54	---	56.00	20.46	L1	OFF	19.6
1.981770	---	27.87	46.00	18.13	L1	OFF	19.6
1.981770	36.15	---	56.00	19.85	L1	OFF	19.6
2.051250	---	27.92	46.00	18.08	L1	OFF	19.7
2.051250	36.07	---	56.00	19.93	L1	OFF	19.7
2.118120	---	28.13	46.00	17.87	L1	OFF	19.7
2.118120	36.22	---	56.00	19.78	L1	OFF	19.7
2.190750	---	27.92	46.00	18.08	L1	OFF	19.7
2.190750	36.09	---	56.00	19.91	L1	OFF	19.7
2.251500	---	28.09	46.00	17.91	L1	OFF	19.7
2.251500	36.31	---	56.00	19.69	L1	OFF	19.7
2.377500	---	28.11	46.00	17.89	L1	OFF	19.7
2.377500	35.79	---	56.00	20.21	L1	OFF	19.7
2.473170	---	27.96	46.00	18.04	L1	OFF	19.7
2.473170	35.68	---	56.00	20.32	L1	OFF	19.7
6.238500	---	27.47	50.00	22.53	L1	OFF	19.8

6.238500	30.95	---	60.00	29.05	L1	OFF	19.8
12.930000	---	34.68	50.00	15.32	L1	OFF	20.1
12.930000	41.23	---	60.00	18.77	L1	OFF	20.1
13.255530	---	34.22	50.00	15.78	L1	OFF	20.1
13.255530	40.68	---	60.00	19.32	L1	OFF	20.1
14.646750	---	33.29	50.00	16.71	L1	OFF	20.1
14.646750	41.15	---	60.00	18.85	L1	OFF	20.1
15.288540	---	33.22	50.00	16.78	L1	OFF	20.1
15.288540	42.13	---	60.00	17.87	L1	OFF	20.1
15.753480	---	33.19	50.00	16.81	L1	OFF	20.1
15.753480	42.43	---	60.00	17.57	L1	OFF	20.1
16.606500	---	31.43	50.00	18.57	L1	OFF	20.1
16.606500	41.57	---	60.00	18.43	L1	OFF	20.1
17.425500	---	30.61	50.00	19.39	L1	OFF	20.2
17.425500	41.26	---	60.00	18.74	L1	OFF	20.2
17.992500	---	29.89	50.00	20.11	L1	OFF	20.2
17.992500	40.40	---	60.00	19.60	L1	OFF	20.2

EUT Information

Report NO : 9D0635
 Test Mode : Mode 1
 Test Voltage : 120Vac/60Hz
 Phase : Neutral

Full Spectrum

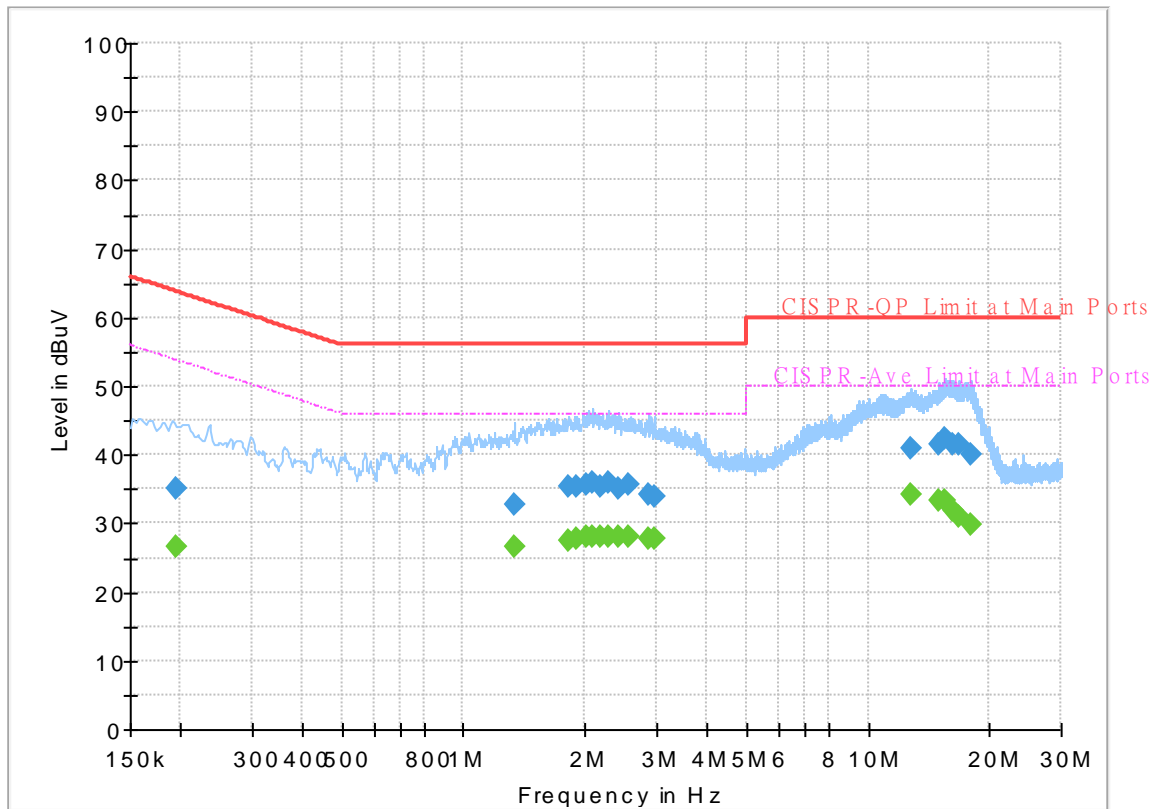

Final_Result

Frequency (MHz)	QuasiPeak (dBuV)	CAverage (dBuV)	Limit (dBuV)	Margin (dB)	Line	Filter	Corr. (dB)
0.195000	---	26.68	53.82	27.14	N	OFF	19.6
0.195000	34.98	---	63.82	28.84	N	OFF	19.6
1.339530	---	26.62	46.00	19.38	N	OFF	19.6
1.339530	32.88	---	56.00	23.12	N	OFF	19.6
1.811220	---	27.51	46.00	18.49	N	OFF	19.6
1.811220	35.37	---	56.00	20.63	N	OFF	19.6
1.902750	---	27.65	46.00	18.35	N	OFF	19.6
1.902750	35.34	---	56.00	20.66	N	OFF	19.6
2.017500	---	28.19	46.00	17.81	N	OFF	19.6
2.017500	35.66	---	56.00	20.34	N	OFF	19.6
2.087250	---	28.04	46.00	17.96	N	OFF	19.6
2.087250	36.07	---	56.00	19.93	N	OFF	19.6
2.170500	---	27.93	46.00	18.07	N	OFF	19.6
2.170500	35.26	---	56.00	20.74	N	OFF	19.6
2.284890	---	27.96	46.00	18.04	N	OFF	19.6
2.284890	35.87	---	56.00	20.13	N	OFF	19.6
2.429160	---	27.98	46.00	18.02	N	OFF	19.6
2.429160	35.09	---	56.00	20.91	N	OFF	19.6
2.571000	---	27.96	46.00	18.04	N	OFF	19.6
2.571000	35.69	---	56.00	20.31	N	OFF	19.6
2.877000	---	27.80	46.00	18.20	N	OFF	19.6

2.877000	34.25	---	56.00	21.75	N	OFF	19.6
2.972850	---	27.79	46.00	18.21	N	OFF	19.7
2.972850	34.03	---	56.00	21.97	N	OFF	19.7
12.748200	---	34.35	50.00	15.65	N	OFF	20.1
12.748200	40.80	---	60.00	19.20	N	OFF	20.1
14.991000	---	33.28	50.00	16.72	N	OFF	20.2
14.991000	41.40	---	60.00	18.60	N	OFF	20.2
15.565560	---	33.29	50.00	16.71	N	OFF	20.2
15.565560	42.40	---	60.00	17.60	N	OFF	20.2
16.228500	---	31.85	50.00	18.15	N	OFF	20.2
16.228500	41.61	---	60.00	18.39	N	OFF	20.2
16.833750	---	31.10	50.00	18.90	N	OFF	20.2
16.833750	41.62	---	60.00	18.38	N	OFF	20.2
18.041910	---	29.69	50.00	20.31	N	OFF	20.3
18.041910	40.06	---	60.00	19.94	N	OFF	20.3



Appendix B. Test Results of Conducted Test Items

B1. Test Result of 20dB Spectrum Bandwidth

Test mode		WPT Tx	
20dB Bandwidth (kHz)	0.774	99% Occupied BW(kHz)	0.654

Remark: Because the measured signal is CW adjusting the RBW per C63.10 would not be practical since measured bandwidth will always follow the RBW and the result will be approximately twice the RBW.



Appendix C. Test Results of Radiated Test Items

C1. Test Result of Field Strength of Fundamental Emissions

Test Mode :	WPT
--------------------	-----

Level (dBuV/m)

Frequency (MHz)

Date: 2020-03-04

Site : 03CH11-HV
 Condition : 3m LOOP_ANT(H)_100488 HORIZONTAL
 : RBW:0.200KHz VBW:0.600KHz SWT:Auto

Over	Limit	ReadAntenna	Cable	A/Pos	T/Pos	Remark				
Freq	Level	Limit	Line	Level	Factor	Loss				
MHz	dBuV/m	dB	dBuV/m	dBuV	dB/m	dB				
1	0.14	38.90	-----	-----	60.29	18.60	0.01	100	167	QP

Level (dBuV/m)

Frequency (MHz)

Date: 2020-03-04

Site : 03CH11-HV
 Condition : 3m LOOP_ANT(V)_100488 VERTICAL
 : RBW:0.200KHz VBW:0.600KHz SWT:Auto

Over	Limit	ReadAntenna	Cable	A/Pos	T/Pos	Remark				
Freq	Level	Limit	Line	Level	Factor	Loss				
MHz	dBuV/m	dB	dBuV/m	dBuV	dB/m	dB				
1	0.14	33.43	-----	-----	54.82	18.60	0.01	100	83	QP



C2. Results of Radiated Spurious Emissions (9 kHz~30MHz)

Test Mode :	WPT Tx	Polarization :	Horizontal
-------------	--------	----------------	------------

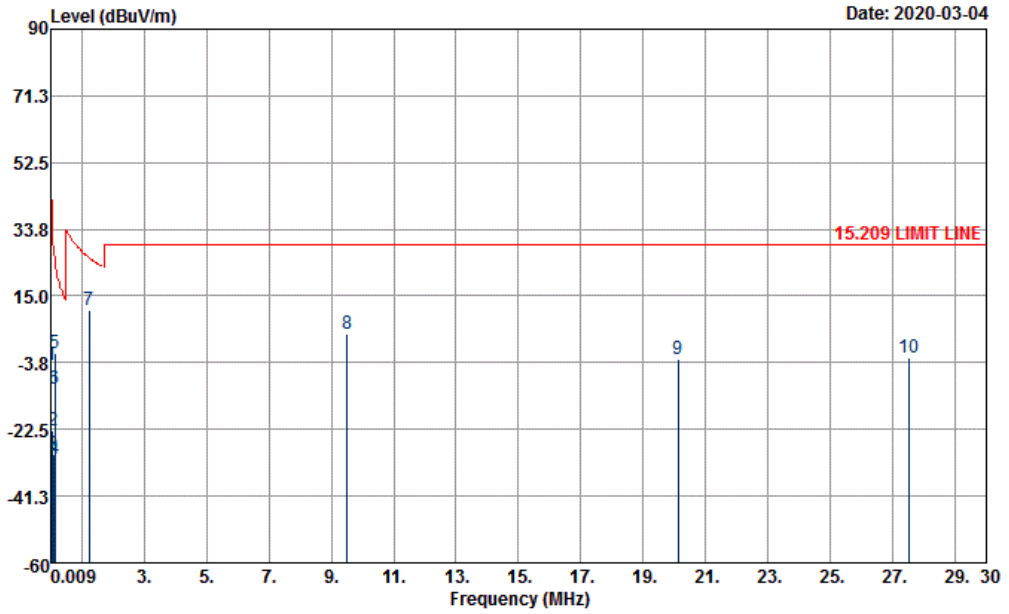

Frequency (MHz)	Level (dBuV/m)	Over Limit (dB)	Limit Line (dBuV/m)	Read Level (dBuV)	Antenna Factor (dB)	Cable Loss (dB)	Ant Pos (cm)	Table Pos (deg)	Remark
0.01925	-4.44	-46.36	41.92	56.42	19.13	0.01	-	-	Average
0.06249	-22.95	-54.64	31.69	38.06	18.98	0.01	-	-	Average
0.09378	-29.63	-57.79	28.16	31.7	18.66	0.01	-	-	QP
0.12504	-30.95	-56.61	25.66	30.44	18.6	0.01	-	-	Average
0.14128	-1.15	-25.75	24.6	60.24	18.6	0.01	-	-	Average
0.15	-11.15	-35.23	24.08	50.24	18.6	0.01	-	-	Average
1.249	11.13	-14.55	25.68	32.52	18.6	0.01	100	0	QP
9.512	4.53	-24.97	29.5	24.21	20.19	0.13	-	-	QP
20.113	-2.76	-32.26	29.5	15.97	21.1	0.17	-	-	QP
27.54	-2.42	-31.92	29.5	16.13	21.25	0.2	-	-	QP

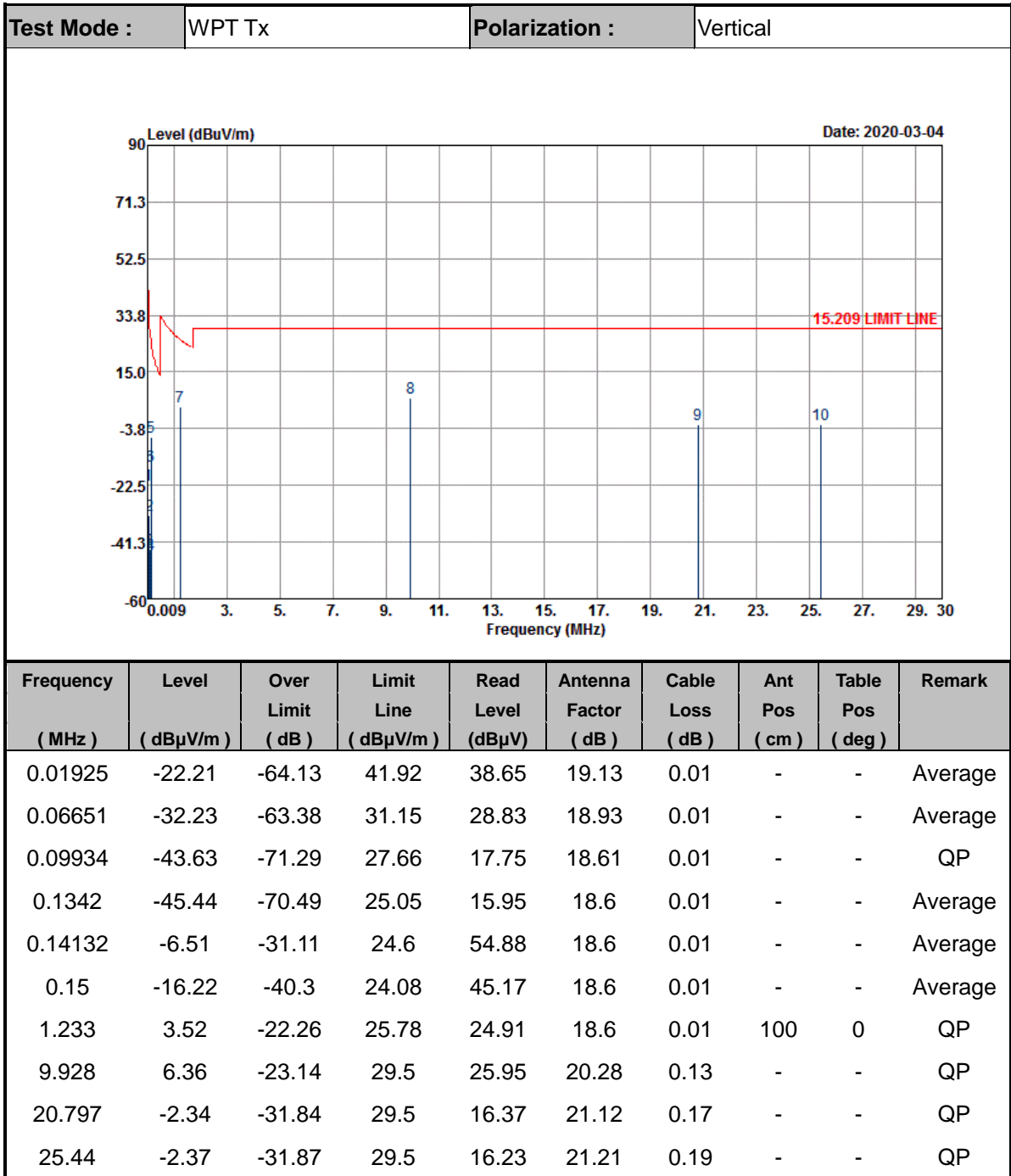

Note:

1. The amplitude of spurious emissions which are attenuated by more than 20dB below the permissible value has no need to be reported.
2. Distance extrapolation factor = 40 log (specific distance / test distance) (dB);
3. Limit line = specific limits (dBμV) + distance extrapolation factor.



C3. Results of Radiated Spurious Emissions (30MHz~1GHz)

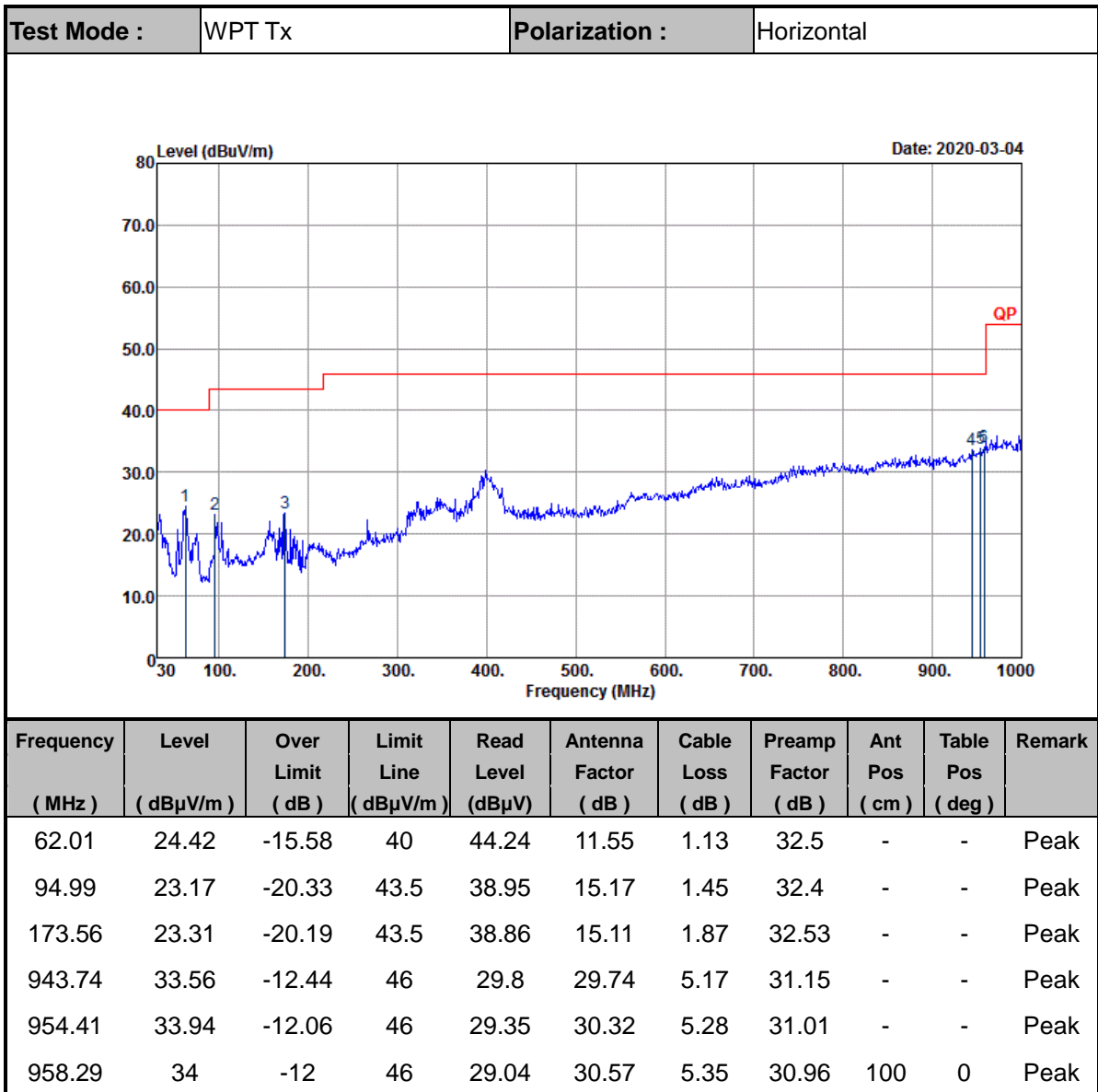



Test Mode :	WPT Tx	Polarization :	Vertical
-------------	--------	----------------	----------

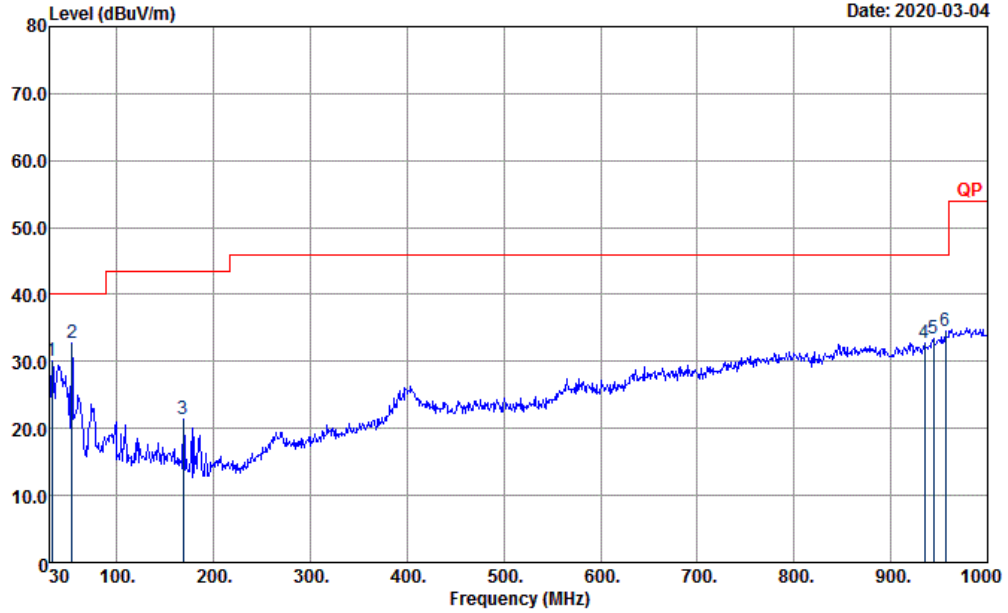

Frequency (MHz)	Level (dBμV/m)	Over Limit (dB)	Limit Line (dBμV/m)	Read Level (dBμV)	Antenna Factor (dB)	Cable Loss (dB)	Preamp Factor (dB)	Ant Pos (cm)	Table Pos (deg)	Remark
32.91	30.16	-9.84	40	38.85	22.8	0.94	32.43	-	-	Peak
53.28	32.74	-7.26	40	51.56	12.68	1.03	32.53	100	0	Peak
168.71	21.44	-22.06	43.5	36.57	15.55	1.84	32.52	-	-	Peak
935.01	32.84	-13.16	46	29.64	29.35	5.12	31.27	-	-	Peak
943.74	33.41	-12.59	46	29.65	29.74	5.17	31.15	-	-	Peak
956.35	34.46	-11.54	46	29.7	30.44	5.31	30.99	-	-	Peak

Note:

1. The amplitude of spurious emissions which are attenuated by more than 20dB below the permissible value has no need to be reported.
2. Emission level (dBμV/m) = 20 log Emission level (μV/m).
3. Corrected Reading: Antenna Factor + Cable Loss + Read Level - Preamp Factor= Level.