



# FCC RADIO TEST REPORT

**FCC ID** : IHDT56YJ2  
**Equipment** : Mobile Cellular Phone  
**Brand Name** : Motorola  
**Model Name** : XT2061-3  
**Applicant** : Motorola Mobility, LLC  
222 W Merchandise Mart Plaza, Suite 1800,  
Chicago, IL 60654, United States  
**Manufacturer** : Motorola Mobility, LLC  
222 W Merchandise Mart Plaza, Suite 1800,  
Chicago, IL 60654, United States  
**Standard** : 47 CFR Part 2, 22(H), 24(E), 27(L)

The product was received on Dec. 06, 2019 and testing was started from Jan. 28, 2020 and completed on Feb. 02, 2020. We, SPORTON INTERNATIONAL INC. EMC & Wireless Communications Laboratory, would like to declare that the tested sample has been evaluated in accordance with the test procedures given in ANSI / TIA-603-E and has been in compliance with the applicable technical standards.

The report must not be used by the client to claim product certification, approval, or endorsement by TAF or any agency of government.

The test results in this variant report apply exclusively to the tested model / sample. Without written approval of SPORTON INTERNATIONAL INC. EMC & Wireless Communications Laboratory, the test report shall not be reproduced except in full.

Louis Wu

Approved by: Louis Wu

**SPORTON INTERNATIONAL INC. EMC & Wireless Communications Laboratory**

No. 52, Huaya 1st Rd., Guishan Dist., Taoyuan City, Taiwan (R.O.C.)



# Table of Contents

**History of this test report.....3**

**Summary of Test Result.....4**

**1 General Description .....5**

    1.1 Product Feature of Equipment Under Test .....5

    1.2 Product Specification of Equipment Under Test .....6

    1.3 Modification of EUT .....6

    1.4 Maximum ERP/EIRP Power, Frequency Tolerance, and Emission Designator .....7

    1.5 Testing Location .....8

    1.6 Applicable Standards .....8

**2 Test Configuration of Equipment Under Test .....9**

    2.1 Test Mode.....9

    2.2 Connection Diagram of Test System .....10

    2.3 Support Unit used in test configuration .....11

    2.4 Measurement Results Explanation Example .....11

    2.5 Frequency List of Low/Middle/High Channels.....12

**3 Conducted Test Result .....13**

    3.1 Measuring Instruments.....13

    3.2 Conducted Output Power and ERP/EIRP .....14

    3.3 Peak-to-Average Ratio .....15

    3.4 99% Occupied Bandwidth and 26dB Bandwidth Measurement.....16

    3.5 Conducted Band Edge .....17

    3.6 Conducted Spurious Emission .....18

    3.7 Frequency Stability.....19

**4 Radiated Test Items .....20**

    4.1 Measuring Instruments.....20

    4.2 Test Setup .....20

    4.3 Test Result of Radiated Test.....21

    4.4 Field Strength of Spurious Radiation Measurement .....22

**5 List of Measuring Equipment.....23**

**6 Uncertainty of Evaluation .....25**

**Appendix A. Test Results of Conducted Test**

**Appendix B. Test Results of ERP/EIRP and Radiated Test**



### History of this test report

Report No.	Version	Description	Issued Date
FG9D0635-01A	01	Initial issue of report	Mar. 03, 2020



### Summary of Test Result

Report Clause	Ref Std. Clause	Test Items	Result (PASS/FAIL)	Remark
3.2	§2.1046	Conducted Output Power	Pass	-
	§22.913 (a)(2)	Effective Radiated Power (GSM850) (WCDMA Band V) (CDMA BC0)		
	§24.232 (c)	Equivalent Isotropic Radiated Power (GSM1900) (WCDMA Band II) (CDMA BC1)		
	§27.50 (d)(4)	Equivalent Isotropic Radiated Power (WCDMA Band IV)		
3.3	§24.232 (d)	Peak-to-Average Ratio	Pass	
3.4	§2.1049	Occupied Bandwidth (GSM850) (WCDMA Band V) (CDMA BC0) (GSM1900) (WCDMA Band II) (CDMA BC1) (WCDMA Band IV)	Pass	-
	§22.917 (b)			
	§24.238 (b)			
	§27.53 (g)			
3.5	§2.1051	Band Edge Measurement (GSM850) (WCDMA Band V) (CDMA BC0) (GSM1900) (WCDMA Band II) (CDMA BC1) (WCDMA Band IV)	Pass	-
	§22.917 (a)			
	§24.238 (a)			
	§27.53 (g)			
3.6	§2.1051	Conducted Emission (GSM850) (WCDMA Band V) (CDMA BC0) (GSM1900) (WCDMA Band II) (CDMA BC1) (WCDMA Band IV)	Pass	-
	§22.917 (a)			
	§24.238 (a)			
	§27.53 (g)			
3.7	§2.1055	Frequency Stability Temperature & Voltage	Pass	-
	§22.355			
	§24.235			
	§27.54			
4.4	§2.1053	Field Strength of Spurious Radiation (GSM850) (WCDMA Band V) (CDMA BC0) (GSM1900) (WCDMA Band II) (CDMA BC1) (WCDMA Band IV)	Pass	Under limit 29.43 dB at 7405.000 MHz
	§22.917 (a)			
	§24.238 (a)			
	§27.53 (h)			

**Remark:**

1. Not required means after assessing, test items are not necessary to carry out.
2. This is a variant report which can be referred Product Equality Declaration. All the test cases were performed on original report which can be referred to Sporton Report Number FG9D0635A. Based on the original report, only worst case was verified.

**Declaration of Conformity:**

The test results with all measurement uncertainty excluded are presented in accordance with the regulation limits or requirements declared by manufacturers.

**Comments and Explanations:**

The declared of product specification for EUT presented in the report are provided by the manufacturer, and the manufacturer takes all the responsibilities for the accuracy of product specification.

**Reviewed by: Wii Chang**  
**Report Producer: Fiona Wu**



# 1 General Description

## 1.1 Product Feature of Equipment Under Test

Product Feature	
Equipment	Mobile Cellular Phone
Brand Name	Motorola
Model Name	XT2061-3
FCC ID	IHDT56YJ2
IMEI Code	<b>Conducted :</b> IMEI: 359124100006175 <b>Radiation :</b> IMEI: 359124100005367
EUT supports Radios application	CDMA/EV-DO/GSM/EGPRS/WCDMA/HSPA/LTE/5G NR/ GNSS/NFC/WPC WLAN 11b/g/n HT20 WLAN 11a/n HT20/HT40 WLAN 11ac VHT20/VHT40/VHT80 WLAN 11ax HE20/HE40/HE80 Bluetooth BR/EDR/LE
HW Version	DVT2
EUT Stage	Identical Prototype

**Remark:** The above EUT's information was declared by manufacturer.

Accessory List	
AC Adapter 1	Brand Name : Motorola
	Model Name : SC-51 (SA18C30116)
	Manufacturer : Chenyang
AC Adapter 2	Brand Name : Motorola
	Model Name : SC-51 (SA18C62985)
	Manufacturer : Acbel
Battery	Brand Name : ATL
	Model Name : LW50
USB Cable 1	Brand Name : Motorola
	Model Name : SC18C24367
	Manufacturer : Saibao
USB Cable 2	Brand Name : Motorola
	Model Name : SC18C24368
	Manufacturer : Luxshare

## 1.2 Product Specification of Equipment Under Test

Standards-related Product Specification	
<b>Tx Frequency</b>	<b>GSM:</b> GSM850: 824.2 MHz ~ 848.8 MHz GSM1900: 1850.2 MHz ~ 1909.8 MHz <b>WCDMA:</b> Band V: 1852.4 MHz ~ 1907.6 MHz Band II: 1852.4 MHz ~ 1907.6 MHz Band IV: 1712.4 MHz ~ 1752.6 MHz <b>CDMA:</b> CDMA2000 BC0: 824.70 MHz ~ 848.31 MHz CDMA2000 BC1: 1851.25 MHz ~ 1908.75 MHz
<b>Rx Frequency</b>	<b>GSM:</b> GSM850: 869.2 MHz ~ 893.8 MHz GSM1900: 1930.2 MHz ~ 1989.8 MHz <b>WCDMA:</b> Band V: 1932.4 MHz ~ 1987.6 MHz Band II: 871.4 MHz ~ 891.6 MHz Band IV: 2112.4 MHz ~ 2152.6 MHz <b>CDMA:</b> CDMA2000 BC0: 869.70 MHz ~ 893.31 MHz CDMA2000 BC1: 1931.25 MHz ~ 1988.75 MHz
<b>Maximum Output Power to Antenna</b>	<b>GSM:</b> GSM850: 32.40 dBm GSM1900: 29.99 dBm <b>WCDMA:</b> Band V: 23.35 dBm Band II: 23.22 dBm Band IV: 23.44 dBm <b>CDMA:</b> CDMA2000 BC0: 23.92 dBm CDMA2000 BC1: 23.99 dBm
<b>Antenna Type</b>	Fixed Internal Antenna
<b>Antenna Gain</b>	Cellular Band: -3.4 dBi PCS Band: -0.9 dBi AWS Band: -1.9 dBi
<b>Type of Modulation</b>	GSM / GPRS: GMSK EGPRS: GMSK for MCS 0 ~ 4 & 8PSK for MCS5 ~9 WCDMA: QPSK (Uplink) HSDPA: 64QAM (Downlink) / HSUPA : QPSK (Uplink) CDMA2000 : QPSK

## 1.3 Modification of EUT

No modifications are made to the EUT during all test items.



### 1.4 Maximum ERP/EIRP Power, Frequency Tolerance, and Emission Designator

FCC Rule	Frequency Range (MHz)	System	Type of Modulation	Maximum ERP/EIRP (W)	Frequency Tolerance (ppm)	Emission Designator
Part 22	824.2 ~848.8	GSM850 GPRS class 8	GMSK	0.4842	-	-
Part 22	824.2 ~848.8	GSM850 EDGE class 8	8PSK	0.1242	-	-
Part 22	826.4 ~846.6	WCDMA Band V RMC 12.2Kbps	QPSK	0.0603	-	-
Part 22	826.4 ~846.6	CDMA BC0 1xRTT	QPSK	0.0687	-	-
Part 22	826.4 ~846.6	CDMA BC0 1xEV-DO Rev. 0	QPSK	0.0671	-	-
Part 24	1850.2 ~1909.8	GSM1900 GPRS class 8	GMSK	0.8110	-	-
Part 24	1850.2 ~1909.8	GSM1900 EDGE class 8	8PSK	0.3020	-	-
Part 24	1850.2 ~1909.8	WCDMA Band II RMC 12.2Kbps	QPSK	0.1706	-	-
Part 24	1850.2 ~1909.8	CDMA BC1 1xRTT	QPSK	0.2032	-	-
Part 24	1850.2 ~1909.8	CDMA BC1 1xEV-DO Rev. 0	QPSK	0.2037	-	-
Part 27	1712.4 ~ 1752.6	WCDMA Band IV RMC 12.2Kbps	QPSK	0.1426	0.0335 ppm	4M16F9W



### 1.5 Testing Location

<b>Test Site</b>	SPORTON INTERNATIONAL INC. EMC & Wireless Communications Laboratory
<b>Test Site Location</b>	No.52, Huaya 1st Rd., Guishan Dist., Taoyuan City, Taiwan (R.O.C.) TEL: +886-3-327-3456 FAX: +886-3-328-4978
<b>Test Site No.</b>	<b>Sporton Site No.</b>
	TH03-HY
<b>Test Engineer</b>	Louis Chung
<b>Temperature</b>	21~24°C
<b>Relative Humidity</b>	51~55%

**Note:** The test site complies with ANSI C63.4 2014 requirement.

<b>Test Site</b>	SPORTON INTERNATIONAL INC. EMC & Wireless Communications Laboratory
<b>Test Site Location</b>	No.58, Aly. 75, Ln. 564, Wenhua 3rd, Rd., Guishan Dist., Taoyuan City, Taiwan (R.O.C.) TEL: +886-3-327-0868 FAX: +886-3-327-0855
<b>Test Site No.</b>	<b>Sporton Site No.</b>
	03CH12-HY
<b>Test Engineer</b>	Chuan Chu
<b>Temperature</b>	22.3~25.3°C
<b>Relative Humidity</b>	55.7~61.9%

**Note:** The test site complies with ANSI C63.4 2014 requirement.

FCC Designation No.: TW1190 and TW0007

### 1.6 Applicable Standards

According to the specifications of the manufacturer, the EUT must comply with the requirements of the following standards:

- ♦ ANSI C63.26-2015
- ♦ ANSI / TIA-603-E
- ♦ 47 CFR Part 2, 22(H), 24(E), 27(L)
- ♦ FCC KDB 971168 D01 Power Meas. License Digital Systems v03r01
- ♦ FCC KDB 412172 D01 Determining ERP and EIRP v01r01
- ♦ FCC KDB 414788 D01 Radiated Test Site v01r01

**Remark:**

1. All test items were verified and recorded according to the standards and without any deviation during the test.
2. This EUT has also been tested and complied with the requirements of FCC Part 15, Subpart B, recorded in a separate test report.



## 2 Test Configuration of Equipment Under Test

### 2.1 Test Mode

Antenna port conducted and radiated test items were performed according to KDB 971168 D01 Power Meas. License Digital Systems v03r01 with maximum output power.

For radiated measurement, pre-scanned in three orthogonal panels, X, Y, Z. The worst cases (Z Plane for Cellular Band; Y Plane PCS Band, AWS Band, and WPC mode) were recorded in this report.

Radiated emissions were investigated as following frequency range:

1. 30 MHz to 9000 MHz for GSM850 and WCDMA Band V and CDMA BC0
2. 30 MHz to 18000 MHz for WCDMA Band IV
3. 30 MHz to 19100 MHz for GSM1900 and WCDMA Band II and CDMA BC1

All modes and data rates and positions were investigated.

Test modes are chosen to be reported as the worst case configuration below:

Test Modes		
Band	Radiated TCs	Conducted TCs
GSM850	<ul style="list-style-type: none"> <li>■ GPRS Class 8 Link</li> <li>■ EDGE Class 8 Link</li> </ul>	-
GSM1900	<ul style="list-style-type: none"> <li>■ GPRS Class 8 Link</li> <li>■ EDGE Class 8 Link</li> </ul>	-
WCDMA Band V	<ul style="list-style-type: none"> <li>■ RMC 12.2Kbps Link</li> </ul>	-
WCDMA Band II	<ul style="list-style-type: none"> <li>■ RMC 12.2Kbps Link</li> </ul>	-
WCDMA Band IV	<ul style="list-style-type: none"> <li>■ RMC 12.2Kbps Link</li> </ul>	<ul style="list-style-type: none"> <li>■ RMC 12.2Kbps Link</li> </ul>
CDMA BC0	<ul style="list-style-type: none"> <li>■ 1xRTT Link</li> <li>■ 1xEV-DO Link</li> </ul>	-
CDMA BC1	<ul style="list-style-type: none"> <li>■ 1xRTT Link</li> <li>■ 1xEV-DO Link</li> </ul>	-

**Remark:** All the radiated test cases were performed with Adapter 1 and USB Cable 1.

## 2.2 Connection Diagram of Test System

<EUT without Accessory>



<EUT with Accessory>

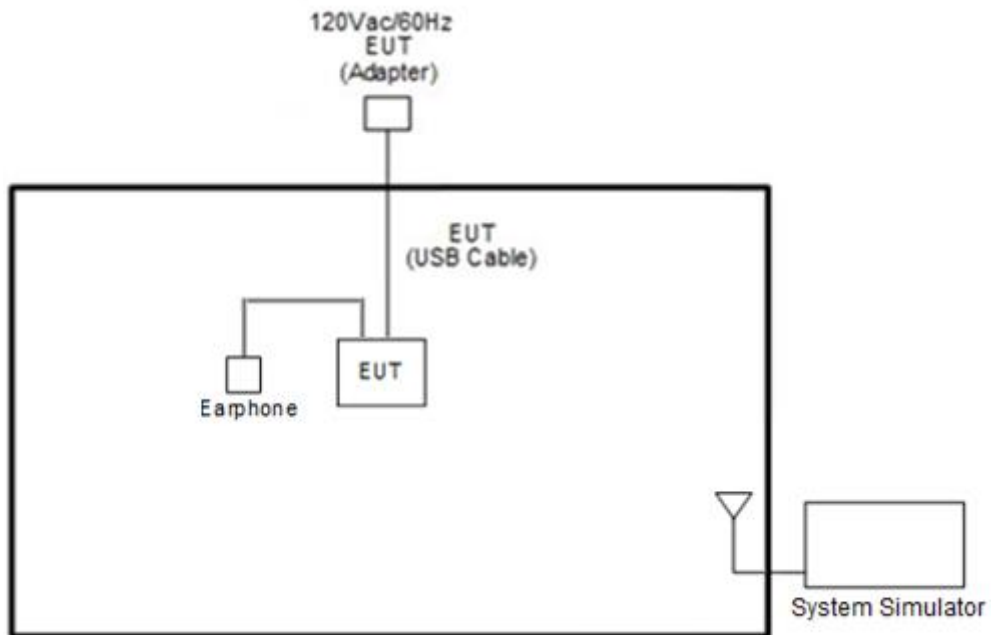

<WPC Mode>

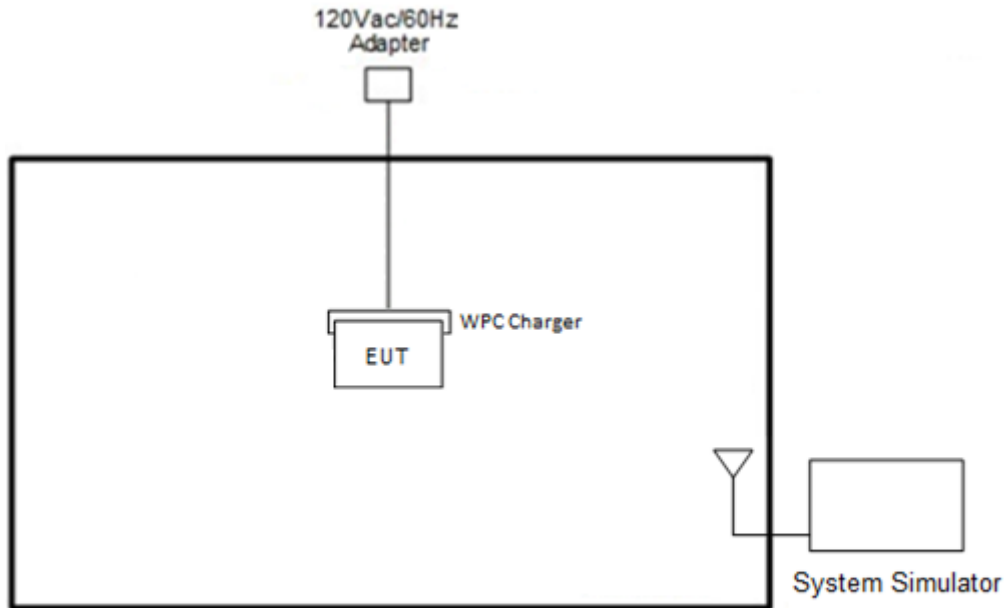

### 2.3 Support Unit used in test configuration

Item	Equipment	Trade Name	Model Name	FCC ID	Data Cable	Power Cord
1.	System Simulator	R&S	CMU 200	N/A	N/A	Unshielded, 1.8 m
2.	Wireless Charger Stand	Samsung	EP-NG930	N/A	N/A	N/A
3.	Adapter	N/A	N/A	N/A	N/A	N/A
4.	USB Cable	N/A	N/A	N/A	N/A	N/A
5.	Earphone	Moto	NASH38C16618	N/A	Unshielded, 1.0 m	N/A

### 2.4 Measurement Results Explanation Example

**For all conducted test items:**

The offset level is set in the spectrum analyzer to compensate the RF cable loss and attenuator factor between RF conducted output port and spectrum analyzer. With the offset compensation, the spectrum analyzer reading level will be exactly the RF output level.

The spectrum analyzer offset is derived from RF cable loss and attenuator factor.

*Offset = RF cable loss + attenuator factor.*

The following shows an offset computation example with RF cable loss 4.2 dB and a 10dB attenuator.

Example:

$$\begin{aligned}
 \text{Offset(dB)} &= \text{RF cable loss(dB)} + \text{attenuator factor(dB)}. \\
 &= 4.2 + 10 = 14.2 \text{ (dB)}
 \end{aligned}$$



## 2.5 Frequency List of Low/Middle/High Channels

Frequency List				
Band	Channel/Frequency(MHz)	Lowest	Middle	Highest
GSM850	Channel	128	189	251
	Frequency	824.2	836.4	848.8
WCDMA Band V	Channel	4132	4182	4233
	Frequency	826.4	836.4	846.6
GSM1900	Channel	512	661	810
	Frequency	1850.2	1880.0	1909.8
WCDMA Band II	Channel	9262	9400	9538
	Frequency	1852.4	1880.0	1907.6
WCDMA Band IV	Channel	1312	1413	1513
	Frequency	1712.4	1732.6	1752.6
CDMA2000 BC0	Channel	1013	384	777
	Frequency	824.7	836.52	848.31
CDMA2000 BC1	Channel	25	600	1175
	Frequency	1851.25	1880.0	1908.75

### 3 Conducted Test Result

#### 3.1 Measuring Instruments

See list of measuring instruments of this test report.

##### 3.1.1 Test Setup

##### 3.1.2 Conducted Output Power

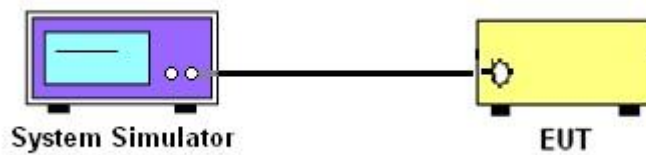

##### 3.1.3 Peak-to-Average Ratio, Occupied Bandwidth, Conducted Band-Edge and Conducted Spurious Emission

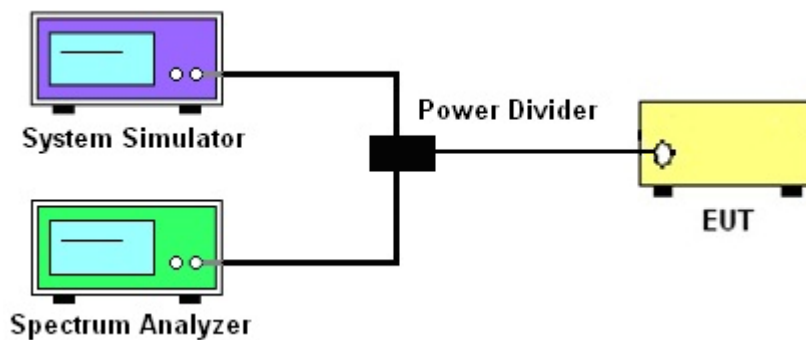

##### 3.1.4 Frequency Stability

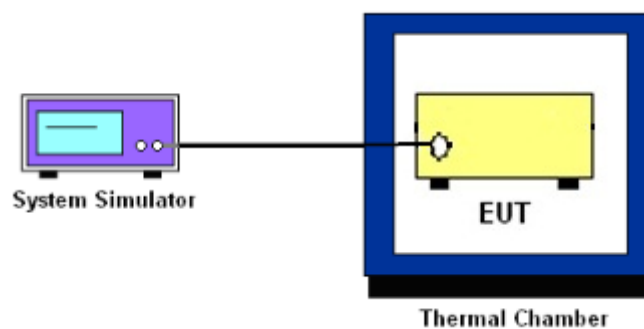

##### 3.1.5 Test Result of Conducted Test

Please refer to Appendix A.



## 3.2 Conducted Output Power and ERP/EIRP

### 3.2.1 Description of the Conducted Output Power and ERP/EIRP

A system simulator was used to establish communication with the EUT. Its parameters were set to enforce EUT transmitting at the maximum power. The measured power in the radio frequency on the transmitter output terminals shall be reported.

The ERP of mobile transmitters must not exceed 7 Watts for GSM850 and WCDMA Band V and CDMA BC0

The EIRP of mobile transmitters must not exceed 2 Watts for GSM1900 and WCDMA Band II and CDMA BC1

The EIRP of mobile transmitters must not exceed 1 Watts for WCDMA Band IV

According to KDB 412172 D01 Power Approach,

$EIRP = P_T + G_T - L_C$ ,  $ERP = EIRP - 2.15$ , where

$P_T$  = transmitter output power in dBm

$G_T$  = gain of the transmitting antenna in dBi

$L_C$  = signal attenuation in the connecting cable between the transmitter and antenna in dB

### 3.2.2 Test Procedures

1. The transmitter output port was connected to the system simulator.
2. Set EUT at maximum power through system simulator.
3. Select lowest, middle, and highest channels for each band and different modulation.
4. Measure the maximum burst average power for GSM and maximum average power for other modulation signal.



### **3.3 Peak-to-Average Ratio**

#### **3.3.1 Description of the PAR Measurement**

The peak-to-average ratio (PAR) of the transmission may not exceed 13 dB.

#### **3.3.2 Test Procedures**

The testing follows ANSI C63.26-2015 Section 5.2.6

1. The EUT was connected to spectrum analyzer and system simulator via a power divider.
2. Set EUT to transmit at maximum output power.
3. When the duty cycle is less than 98%, then signal gating will be implemented on the spectrum analyzer by triggering from the system simulator.
4. Set the CCDF (Complementary Cumulative Distribution Function) option of the spectrum analyzer.
5. Record the maximum PAPR level associated with a probability of 0.1%.



## 3.4 99% Occupied Bandwidth and 26dB Bandwidth Measurement

### 3.4.1 Description of 99% Occupied Bandwidth and 26dB Bandwidth Measurement

The occupied bandwidth is the width of a frequency band such that, below the lower and above the upper frequency limits, the mean powers emitted are each equal to a specified percentage 0.5% of the total mean transmitted power.

The 26 dB emission bandwidth is defined as the frequency range between two points, one above and one below the carrier frequency, at which the spectral density of the emission is attenuated 26 dB below the maximum in-band spectral density of the modulated signal. Spectral density (power per unit bandwidth) is to be measured with a detector of resolution bandwidth equal to approximately 1.0% of the emission bandwidth.

### 3.4.2 Test Procedures

The testing follows ANSI C63.26-2015 Section 5.4.3 (26dB) and Section 5.4.4 (99OB)

1. The EUT was connected to spectrum analyzer and system simulator via a power divider.
2. The spectrum analyzer center frequency is set to the nominal EUT channel center frequency. The span range for the spectrum analyzer shall be between two and five times the anticipated OBW.
3. The nominal resolution bandwidth (RBW) shall be in the range of 1 to 5 % of the anticipated OBW, and the VBW shall be at least 3 times the RBW.
4. Set the detection mode to peak, and the trace mode to max hold.
5. Determine the reference value: Set the EUT to transmit a modulated signal. Allow the trace to stabilize. Set the spectrum analyzer marker to the highest level of the displayed trace.  
(this is the reference value)
6. Determine the “-26 dB down amplitude” as equal to (Reference Value – X).
7. Place two markers, one at the lowest and the other at the highest frequency of the envelope of the spectral display such that each marker is at or slightly below the “-X dB down amplitude” determined in step 6. If a marker is below this “-X dB down amplitude” value it shall be placed as close as possible to this value. The OBW is the positive frequency difference between the two markers.
8. Use the 99 % power bandwidth function of the spectrum analyzer and report the measured bandwidth.



## **3.5 Conducted Band Edge**

### **3.5.1 Description of Conducted Band Edge Measurement**

The power of any emission outside of the authorized operating frequency ranges must be lower than the transmitter power (P) by a factor of at least  $43 + 10 \log (P)$  dB.

### **3.5.2 Test Procedures**

The testing follows FCC KDB 971168 D01 v03r01 Section 6.1.

1. The EUT was connected to the spectrum analyzer and system simulator via a power divider.
2. The RF output of EUT was connected to the spectrum analyzer by an RF cable and attenuator. The path loss was compensated to the results for each measurement.
3. The band edges of low and high channels for the highest RF powers were measured.
4. The RF fundamental frequency should be excluded against the limit line in the operating frequency band.
5. The limit line is derived from  $43 + 10\log(P)$  dB below the transmitter power P(Watts)



## **3.6 Conducted Spurious Emission**

### **3.6.1 Description of Conducted Spurious Emission Measurement**

The power of any emission outside of the authorized operating frequency ranges must be lower than the transmitter power (P) by a factor of at least  $43 + 10 \log (P)$  dB.

It is measured by means of a calibrated spectrum analyzer and scanned from 30 MHz up to a frequency including its 10<sup>th</sup> harmonic.

### **3.6.2 Test Procedures**

The testing follows FCC KDB 971168 D01 v03r01 Section 6.1.

1. The EUT was connected to the spectrum analyzer and system simulator via a power divider.
2. The RF output of EUT was connected to the spectrum analyzer by an RF cable and attenuator.  
The path loss was compensated to the results for each measurement.
3. The middle channel for the highest RF power within the transmitting frequency was measured.
4. The conducted spurious emission for the whole frequency range was taken.
5. The RF fundamental frequency should be excluded against the limit line in the operating frequency band.
6. The limit line is derived from  $43 + 10\log(P)$  dB below the transmitter power P(Watts)



### 3.7 Frequency Stability

#### 3.7.1 Description of Frequency Stability Measurement

22.355

The frequency stability shall be measured by variation of ambient temperature and variation of primary supply voltage to ensure that the fundamental emission stays within the authorized frequency block. The frequency stability of the transmitter shall be maintained within  $\pm 0.00025\%$  ( $\pm 2.5\text{ppm}$ ) of the center frequency.

24.235 & 27.54

The frequency stability shall be sufficient to ensure that the fundamental emission stays within the authorized frequency block.

#### 3.7.2 Test Procedures for Temperature Variation

The testing follows FCC KDB 971168 D01 v03r01 Section 9.0.

1. The EUT was set up in the thermal chamber and connected with the system simulator.
2. With power OFF, the temperature was decreased to  $-30^{\circ}\text{C}$  and the EUT was stabilized before testing. Power was applied and the maximum change in frequency was recorded within one minute.
3. With power OFF, the temperature was raised in  $10^{\circ}\text{C}$  steps up to  $50^{\circ}\text{C}$ . The EUT was stabilized at each step for at least half an hour. Power was applied and the maximum frequency change was recorded within one minute.

#### 3.7.3 Test Procedures for Voltage Variation

The testing follows FCC KDB 971168 D01 v03r01 Section 9.0.

1. The EUT was placed in a temperature chamber at  $20\pm 5^{\circ}\text{C}$  and connected with the system simulator.
2. The power supply voltage to the EUT was varied from 85% to 115% of the nominal value measured at the input to the EUT.
3. The variation in frequency was measured for the worst case.

## 4 Radiated Test Items

### 4.1 Measuring Instruments

See list of measuring instruments of this test report.

### 4.2 Test Setup

For radiated emissions below 30MHz

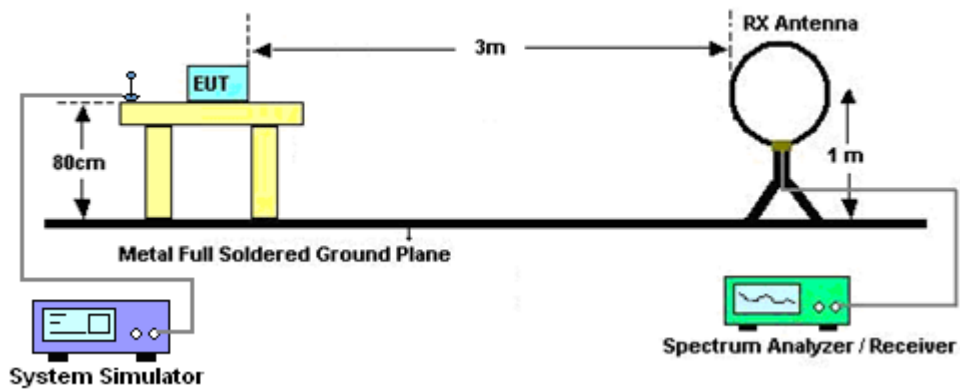

For radiated test from 30MHz to 1GHz

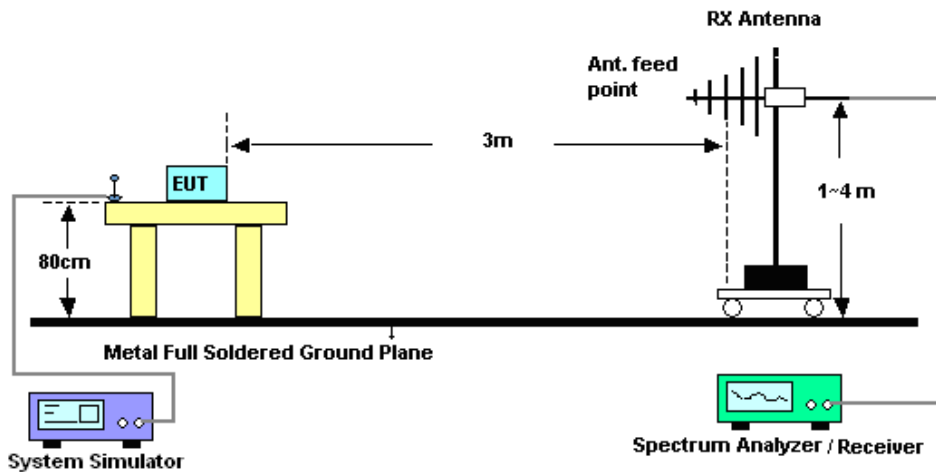

For radiated test above 1GHz

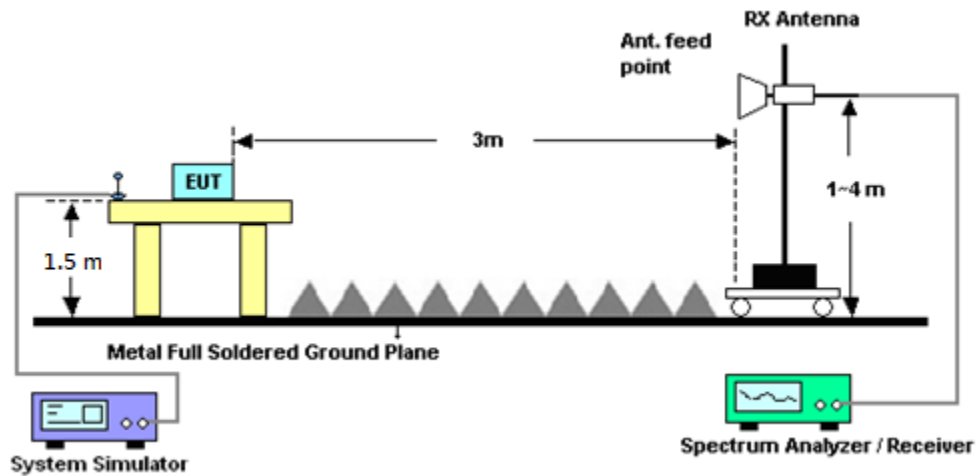

### 4.3 Test Result of Radiated Test

Please refer to Appendix B.

**Note:**

The low frequency, which started from 9 kHz to 30MHz, was pre-scanned and the result which was 20dB lower than the limit line was not reported.

There is a comparison data of both open-field test site and alternative test site - semi-Anechoic chamber according to 414788 D01 Radiated Test Site v01r01, and the result came out very similar.



## 4.4 Field Strength of Spurious Radiation Measurement

### 4.4.1 Description of Field Strength of Spurious Radiated Measurement

The power of any emission outside of the authorized operating frequency ranges must be attenuated below the transmitter power (P) by a factor of at least  $43 + 10 \log (P)$  dB. The spectrum is scanned from 30 MHz up to a frequency including its 10th harmonic.

### 4.4.2 Test Procedures

The testing follows FCC KDB 971168 D01 v03r01 Section 7 and ANSI / TIA-603-E Section 2.2.12.

1. The EUT was placed on a rotatable wooden table 0.8 meters for frequency below 1GHz and 1.5 meter for frequency above 1GHz above the ground.
2. The EUT was set 3 meters from the receiving antenna, which was mounted on the antenna tower.
3. The table was rotated 360 degrees to determine the position of the highest spurious emission.
4. The height of the receiving antenna is varied between one meter and four meters to search for the maximum spurious emission for both horizontal and vertical polarizations.
5. Make the measurement with the spectrum analyzer's RBW = 1MHz, VBW = 3MHz, taking record of maximum spurious emission.
6. A horn antenna was substituted in place of the EUT and was driven by a signal generator.
7. Tune the output power of signal generator to the same emission level with EUT maximum spurious emission.
8. Taking the record of output power at antenna port.
9. Repeat step 7 to step 8 for another polarization.
10.  $EIRP (dBm) = S.G. Power - Tx Cable Loss + Tx Antenna Gain$
11.  $ERP (dBm) = EIRP - 2.15$
12. The RF fundamental frequency should be excluded against the limit line in the operating frequency band.
13. The limit line is derived from  $43 + 10\log(P)$  dB below the transmitter power P(Watts)



## 5 List of Measuring Equipment

Instrument	Manufacturer	Model No.	Serial No.	Characteristics	Calibration Date	Test Date	Due Date	Remark
Loop Antenna	Rohde & Schwarz	HFH2-Z2	100315	9 kHz~30 MHz	Dec. 26, 2019	Jan. 28, 2020~ Feb. 02, 2020	Dec. 25, 2020	Radiation (03CH12-HY)
Bilog Antenna	TESEQ	CBL 6111D & 00800N1D01N -06	41912 & 05	30MHz~1GHz	Feb. 12, 2019	Jan. 28, 2020~ Feb. 02, 2020	Feb 11, 2020	Radiation (03CH12-HY)
Horn Antenna	SCHWARZBE CK	BBHA 9120D	9120D-1328	1GHz ~ 18GHz	Nov. 14, 2019	Jan. 28, 2020~ Feb. 02, 2020	Nov. 13, 2020	Radiation (03CH12-HY)
SHF-EHF Horn Antenna	SCHWARZBE CK	BBHA 9170	BBHA917058 4	18GHz ~ 40GHz	Dec. 10, 2019	Jan. 28, 2020~ Feb. 02, 2020	Dec. 09, 2020	Radiation (03CH12-HY)
Preamplifier	COM-POWER	PA-103	161075	10MHz~1GHz	Mar. 25, 2019	Jan. 28, 2020~ Feb. 02, 2020	Mar. 24, 2020	Radiation (03CH12-HY)
Preamplifier	Jet-Power	JPA00101800- 30-10P	1601180002	1GHz~18GHz	Aug. 01, 2019	Jan. 28, 2020~ Feb. 02, 2020	Jul. 01, 2020	Radiation (03CH12-HY)
Preamplifier	EMEC	EM18G40G	060715	18GHz ~ 40GHz	Dec. 13, 2019	Jan. 28, 2020~ Feb. 02, 2020	Dec. 12, 2020	Radiation (03CH12-HY)
Preamplifier	Agilent	8449B	3008A02375	1GHz~26.5GHz	May 27, 2019	Jan. 28, 2020~ Feb. 02, 2020	May 26, 2020	Radiation (03CH12-HY)
Spectrum Analyzer	Keysight	N9010A	MY55370526	10Hz~44GHz	Mar. 19, 2019	Jan. 28, 2020~ Feb. 02, 2020	Mar. 18, 2020	Radiation (03CH12-HY)
Signal Generator	Rohde & Schwarz	SMB100A	101107	100kHz~40GHz	Aug. 27, 2019	Jan. 28, 2020~ Feb. 02, 2020	Aug. 26, 2020	Radiation (03CH12-HY)
Hygrometer	TECPEL	DTM-303B	TP161243	N/A	May 11, 2019	Jan. 28, 2020~ Feb. 02, 2020	May 10, 2020	Radiation (03CH12-HY)
RF Cable	HUBER + SUHNER	SUCOFLEX 126E	0058/126E	30M-18G	Mar. 13, 2019	Jan. 28, 2020~ Feb. 02, 2020	Mar. 12, 2020	Radiation (03CH12-HY)
RF Cable	HUBER + SUHNER	SUCOFLEX 102	505134/2	30M~40GHz	Feb. 26, 2019	Jan. 28, 2020~ Feb. 02, 2020	Feb. 25, 2020	Radiation (03CH12-HY)
RF Cable	HUBER + SUHNER	SUCOFLEX 102	800740/2	30M~40GHz	Feb. 26, 2019	Jan. 28, 2020~ Feb. 02, 2020	Feb. 25, 2020	Radiation (03CH12-HY)
Base Station	Anritsu	MT8821C	6201432816	GSM / GPRS /WCDMA / LTE FDD/TDD with 44) /LTE-3CC DLCA,2CC ULCA	May 05, 2019	Jan. 28, 2020~ Feb. 02, 2020	May 04, 2020	Radiation (03CH12-HY)
Controller	EMEC	EM1000	N/A	Control Turn table & Ant Mast	N/A	Jan. 28, 2020~ Feb. 02, 2020	N/A	Radiation (03CH12-HY)
Antenna Mast	EMEC	AM-BS-4500-B	N/A	1m~4m	N/A	Jan. 28, 2020~ Feb. 02, 2020	N/A	Radiation (03CH12-HY)
Turn Table	EMEC	TT2000	N/A	0~360 Degree	N/A	Jan. 28, 2020~ Feb. 02, 2020	N/A	Radiation (03CH12-HY)
Software	Audix	E3 6.2009-8-24	RK-000989	N/A	N/A	Jan. 28, 2020~ Feb. 02, 2020	N/A	Radiation (03CH12-HY)



Instrument	Manufacturer	Model No.	Serial No.	Characteristics	Calibration Date	Test Date	Due Date	Remark
Hygrometer	Testo	608-H1	34893241	N/A	Mar. 06, 2019	Feb. 02, 2020	Mar. 05, 2020	Conducted (TH03-HY)
Spectrum Analyzer	Rohde & Schwarz	FSP30	101329	9kHz~30GHz	Sep. 04, 2019	Feb. 02, 2020	Sep. 03, 2020	Conducted (TH03-HY)
Temperature Chamber	ESPEC	SU-641	92013721	-30°C ~70°C	Nov. 26, 2019	Feb. 02, 2020	Nov. 25, 2020	Conducted (TH03-HY)
Programmable Power Supply	GW Instek	PSS-2005	EL890001	1V~20V 0.5A~4A	Oct. 09, 2019	Feb. 02, 2020	Oct. 08, 2020	Conducted (TH03-HY)
Base Station(Measur e)	Rohde & Schwarz	CMU200	117995	GSM / GPRS / WCDMA / CDMA	Aug. 23, 2019	Feb. 02, 2020	Aug. 22, 2020	Conducted (TH03-HY)
Power Divider	Warison	WCOU-0.4-26. 5S-20	#A	N/A	Nov. 06, 2019	Feb. 02, 2020	Nov. 05, 2020	Conducted (TH03-HY)



## 6 Uncertainty of Evaluation

### Uncertainty of Radiated Emission Measurement (30 MHz ~ 1000 MHz)

Measuring Uncertainty for a Level of Confidence of 95% (U = 2Uc(y))	3.24
---	------

### Uncertainty of Radiated Emission Measurement (1 GHz ~ 18 GHz)

Measuring Uncertainty for a Level of Confidence of 95% (U = 2Uc(y))	3.62
---	------

### Uncertainty of Radiated Emission Measurement (18 GHz ~ 40 GHz)

Measuring Uncertainty for a Level of Confidence of 95% (U = 2Uc(y))	4.06
---	------



## Appendix A. Test Results of Conducted Test

### Conducted Output Power(Average power)

Conducted Power (*Unit: dBm)						
Band	GSM850			GSM1900		
Channel	128	189	251	512	661	810
Frequency	824.2	836.4	848.8	1850.2	1880	1909.8
GSM	32.25	32.23	32.24	29.99	29.98	29.95
GPRS class 8	32.39	32.40	32.29	29.89	29.95	29.61
GPRS class 10	31.73	31.33	30.94	28.78	28.81	28.72
GPRS class 11	30.23	29.56	28.94	27.02	27.08	27.05
GPRS class 12	28.56	27.73	27.03	25.43	25.47	25.53
EGPRS class 8	26.40	26.44	26.49	25.53	25.50	25.70
EGPRS class 10	25.59	25.57	25.64	24.69	24.70	24.82
EGPRS class 11	23.92	23.90	24.01	23.01	23.11	23.21
EGPRS class 12	22.39	22.31	22.38	21.51	21.52	21.70

Conducted Power (*Unit: dBm)						
Band	WCDMA Band V			WCDMA Band II		
Channel	4132	4182	4233	9262	9400	9538
Frequency	826.4	836.4	846.6	1852.4	1880	1907.6
RMC 12.2K	23.21	23.22	23.35	23.12	23.22	23.19
HSDPA Subtest-1	21.86	21.66	21.87	21.90	21.75	21.89
HSDPA Subtest-2	21.85	21.69	21.93	22.00	21.77	21.61
HSDPA Subtest-3	21.35	21.20	21.38	21.40	21.36	21.44
HSDPA Subtest-4	21.32	21.21	21.34	21.43	21.24	21.50
HSUPA Subtest-1	21.75	21.77	21.89	21.89	21.80	21.97
HSUPA Subtest-2	19.80	19.71	19.85	19.85	19.74	19.95
HSUPA Subtest-3	20.72	20.70	20.87	20.89	20.84	20.71
HSUPA Subtest-4	19.81	19.75	19.84	19.96	19.77	19.65
HSUPA Subtest-5	21.79	21.60	21.90	21.82	21.78	21.65



Conducted Power (*Unit: dBm)			
Band	WCDMA Band IV		
Channel	1312	1413	1513
Frequency	1712.4	1732.6	1752.6
RMC 12.2K	23.31	<b>23.44</b>	23.32
HSDPA Subtest-1	21.92	21.81	21.98
HSDPA Subtest-2	21.97	21.85	21.95
HSDPA Subtest-3	21.46	21.28	21.49
HSDPA Subtest-4	21.38	21.33	21.47
HSUPA Subtest-1	21.90	21.81	21.99
HSUPA Subtest-2	19.87	19.80	19.98
HSUPA Subtest-3	20.81	20.78	20.99
HSUPA Subtest-4	19.91	19.78	19.95
HSUPA Subtest-5	21.90	21.70	21.61

Conducted Power (*Unit: dBm)						
Band	CDMA 2000 BC0			CDMA 2000 BC1		
Channel	1013	384	777	25	600	1175
Frequency	824.7	836.52	848.31	1851.25	1880	1908.75
1xRTT RC1 SO55	23.56	23.69	<b>23.92</b>	23.95	23.94	23.95
1xRTT RC3 SO55	23.76	23.69	23.81	<b>23.98</b>	23.95	23.90
1xRTT RC3 SO32 (+ F-SCH)	<b>23.92</b>	23.70	23.75	23.93	23.90	23.92
1xRTT RC3 SO32 (+SCH)	23.61	23.64	23.59	23.85	23.80	23.95
1xEVDO RTAP 153.6Kbps	23.61	23.77	23.53	<b>23.99</b>	23.80	<b>23.99</b>
1xEVDO RETAP 4096Bits	23.47	<b>23.82</b>	<b>23.82</b>	23.95	23.75	23.96



## A2. WCDMA

### Peak-to-Average Ratio

Mode	WCDMA Band IV	Limit: 13dB
Mod.	RMC 12.2Kbps	Result
Lowest CH	2.92	<b>PASS</b>
Middle CH	2.92	
Highest CH	2.88	



### WCDMA Band IV (RMC 12.2Kbps)

#### Lowest Channel

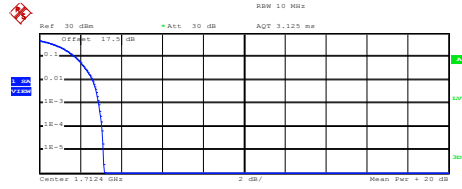

Complementary Cumulative Distribution Function (100000 samples)

Trace 1  
Mean 22.27 dBm  
Peak 25.43 dBm  
Crest 3.16 dB

10 % 1.76 dB  
1 % 2.60 dB  
.1 % 2.92 dB  
.01 % 3.08 dB

Date: 8.FEB.2020 12:07:39

#### Middle Channel

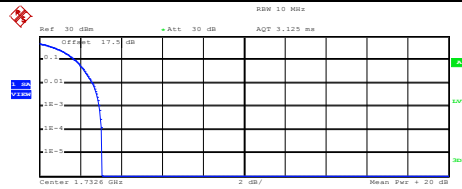

Complementary Cumulative Distribution Function (100000 samples)

Trace 1  
Mean 22.29 dBm  
Peak 25.36 dBm  
Crest 3.07 dB

10 % 1.76 dB  
1 % 2.60 dB  
.1 % 2.92 dB  
.01 % 3.04 dB

Date: 8.FEB.2020 12:08:12

#### Highest Channel

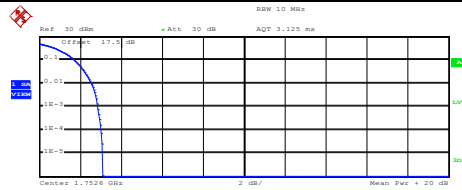

Complementary Cumulative Distribution Function (100000 samples)

Trace 1  
Mean 22.12 dBm  
Peak 25.22 dBm  
Crest 3.10 dB

10 % 1.72 dB  
1 % 2.56 dB  
.1 % 2.88 dB  
.01 % 3.04 dB

Date: 8.FEB.2020 12:08:25



**26dB Bandwidth**

<b>Mode</b>	<b>WCDMA Band IV 26dB BW(MHz)</b>
<b>Mod.</b>	<b>RMC 12.2Kbps</b>
<b>Lowest CH</b>	4.72
<b>Middle CH</b>	4.71
<b>Highest CH</b>	4.72



### WCDMA Band IV (RMC 12.2Kbps)

#### Lowest Channel

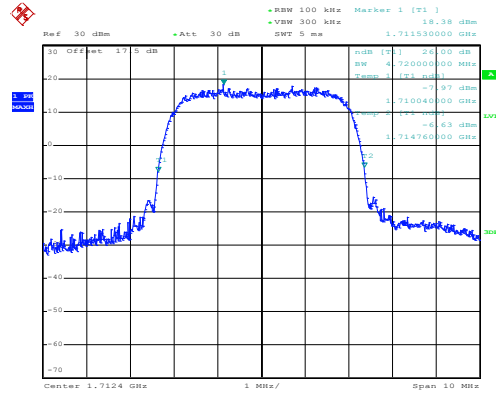

Date: 8.FEB.2020 12:02:42

#### Middle Channel

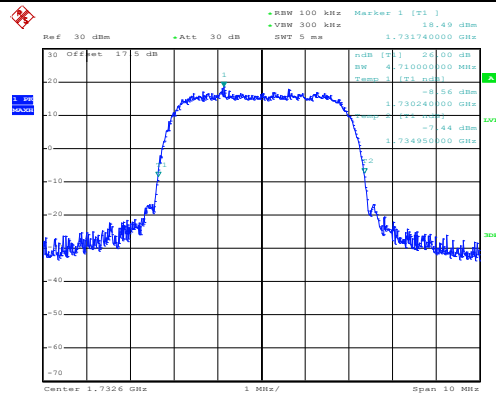

Date: 8.FEB.2020 12:03:22

#### Highest Channel

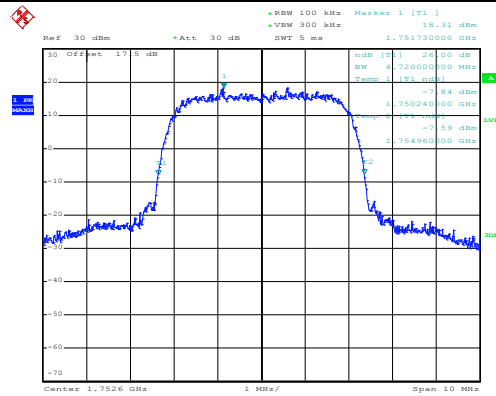

Date: 8.FEB.2020 12:03:59



### Occupied Bandwidth

<b>Mode</b>	<b>WCDMA Band IV 99% OBW(MHz)</b>
<b>Mod.</b>	<b>RMC 12.2Kbps</b>
<b>Lowest CH</b>	4.16
<b>Middle CH</b>	4.15
<b>Highest CH</b>	4.15



### WCDMA Band IV (RMC 12.2Kbps)

#### Lowest Channel

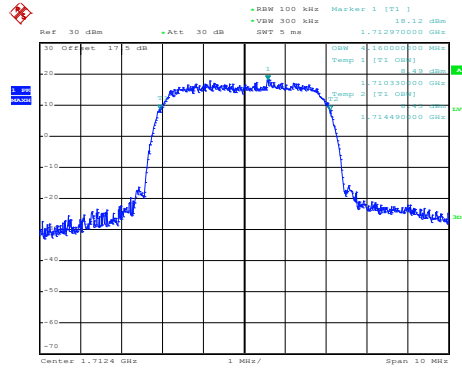

Date: 8.FEB.2020 12:09:03

#### Middle Channel

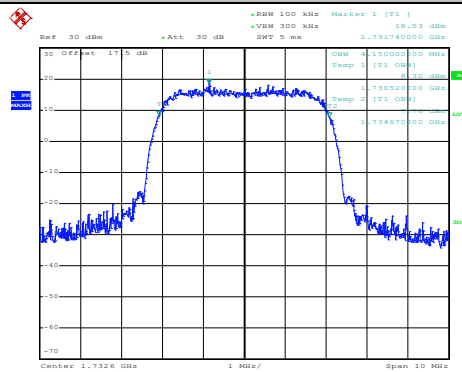

Date: 8.FEB.2020 12:09:39

#### Highest Channel

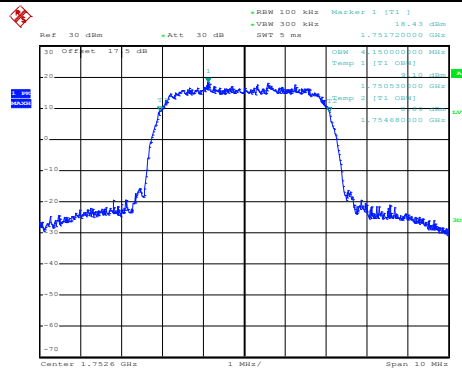

Date: 8.FEB.2020 12:10:13



# Conducted Band Edge

## WCDMA Band IV (RMC 12.2Kbps)

### Lowest Band Edge

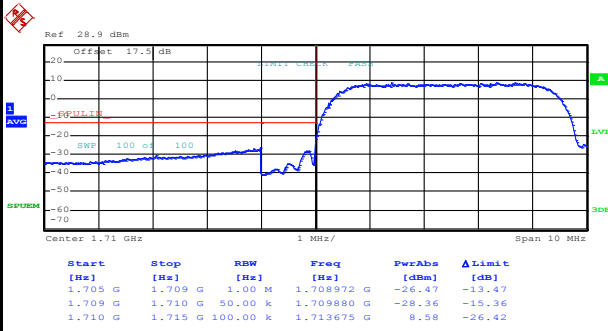

Date: 8.FEB.2020 12:13:14

### Highest Band Edge

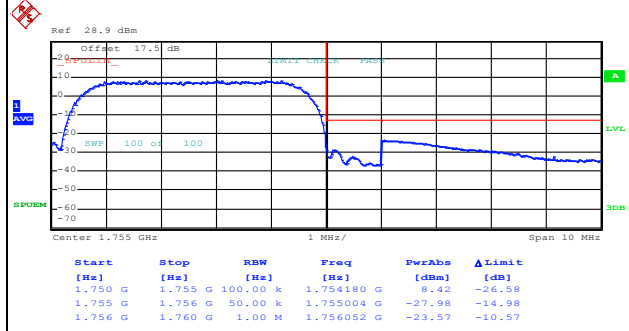

Date: 8.FEB.2020 12:16:03



# Conducted Spurious Emission

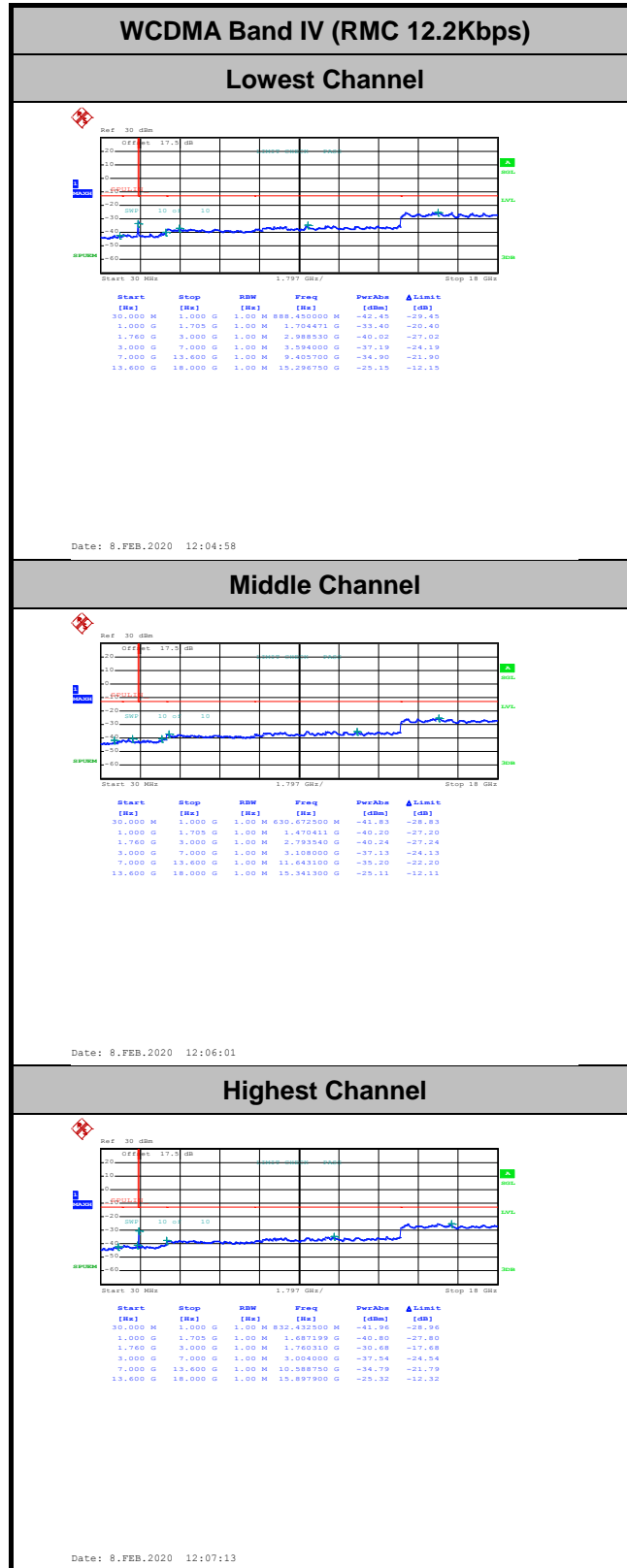



**Frequency Stability**

Test Conditions	Middle Channel	WCDMA Band IV (RMC 12.2Kbps)	Limit Note 2.
Temperature (°C)	Voltage (Volt)	Deviation (ppm)	Result
50	Normal Voltage	0.0087	PASS
40	Normal Voltage	0.0046	
30	Normal Voltage	0.0006	
20(Ref.)	Normal Voltage	0.0000	
10	Normal Voltage	0.0179	
0	Normal Voltage	0.0231	
-10	Normal Voltage	0.0254	
-20	Normal Voltage	0.0214	
-30	Normal Voltage	0.0335	
20	Maximum Voltage	0.0035	
20	Normal Voltage	0.0000	
20	Battery End Point	0.0046	

**Note:**

- 1. Normal Voltage = 3.9V. ; Battery End Point (BEP) = 3.4 V. ; Maximum Voltage =4.35 V
- 2. The frequency fundamental emissions stay within the authorized frequency block.



## Appendix B. Test Results of ERP/EIRP and Radiated Test

### ERP/EIRP

Channel	Mode	Conducted		ERP	
		Power (dBm)	Power (Watts)	ERP(dBm)	ERP(W)
Lowest	GSM850	32.39	1.7338	26.84	0.4831
Middle	GPRS class 8	32.40	1.7378	26.85	0.4842
Highest	(GT - LC = -3.4 dB)	32.29	1.6943	26.74	0.4721
Lowest	GSM850	26.40	0.4365	20.85	0.1216
Middle	EDGE class 8	26.44	0.4406	20.89	0.1227
Highest	(GT - LC = -3.4 dB)	26.49	0.4457	20.94	0.1242
Lowest	WCDMA Band V	23.21	0.2094	17.66	0.0583
Middle	RMC 12.2Kbps	23.22	0.2099	17.67	0.0585
Highest	(GT - LC = -3.4 dB)	23.35	0.2163	17.80	0.0603
Lowest	CDMA BC0	23.56	0.2270	18.01	0.0632
Middle	1xRTT	23.69	0.2339	18.14	0.0652
Highest	(GT - LC = -3.4 dB)	23.92	0.2466	18.37	0.0687
Lowest	CDMA BC0	23.47	0.2223	17.92	0.0619
Middle	1xEV-DO	23.82	0.2410	18.27	0.0671
Highest	(GT - LC = -3.4 dB)	23.82	0.2410	18.27	0.0671
Limit	ERP < 7W	Result		PASS	

Channel	Mode	Conducted		EIRP	
		Power (dBm)	Power (Watts)	EIRP(dBm)	EIRP(W)
Lowest	GSM1900	29.99	0.9977	29.09	0.8110
Middle	GSM	29.98	0.9954	29.08	0.8091
Highest	(GT - LC = -0.9 dB)	29.95	0.9886	29.05	0.8035
Lowest	GSM1900	25.53	0.3573	24.63	0.2904
Middle	EDGE class 8	25.50	0.3548	24.60	0.2884
Highest	(GT - LC = -0.9 dB)	25.70	0.3715	24.80	0.3020
Lowest	WCDMA Band II	23.12	0.2051	22.22	0.1667
Middle	RMC 12.2Kbps	23.22	0.2099	22.32	0.1706
Highest	(GT - LC = -0.9 dB)	23.19	0.2084	22.29	0.1694
Lowest	CDMA BC1	23.98	0.2500	23.08	0.2032
Middle	1xRTT	23.95	0.2483	23.05	0.2018
Highest	(GT - LC = -0.9 dB)	23.90	0.2455	23.00	0.1995
Lowest	CDMA BC1	23.99	0.2506	23.09	0.2037
Middle	1xEV-DO	23.80	0.2399	22.90	0.1950
Highest	(GT - LC = -0.9 dB)	23.99	0.2506	23.09	0.2037
Limit	EIRP < 2W	Result		PASS	

Channel	Mode	Conducted		EIRP	
		Power (dBm)	Power (Watts)	EIRP(dBm)	EIRP(W)
Lowest	WCDMA Band IV	23.31	0.2143	21.41	0.1384
Middle	RMC 12.2Kbps	23.44	0.2208	21.54	0.1426
Highest	(GT - LC = -1.9 dB)	23.32	0.2148	21.42	0.1387
Limit	EIRP < 1W	Result		PASS	



**Radiated Spurious Emission**

**GPRS850**

GSM 850									
Channel	Frequency ( MHz )	ERP ( dBm )	Limit ( dBm )	Over Limit ( dB )	SPA Reading (dBm)	S.G. Power ( dBm )	TX Cable loss ( dB )	TX Antenna Gain (dBi)	Polarization (H/V)
Lowest	1648	-59.56	-13	-46.56	-69.65	-65.15	0.92	8.66	H
	2472	-43.98	-13	-30.98	-58.29	-51.35	1.14	10.66	H
	3296	-55.52	-13	-42.52	-71.2	-64.06	1.32	12.01	H
									H
									H
									H
									H
	1648	-57.31	-13	-44.31	-66.87	-62.90	0.92	8.66	V
	2472	-43.48	-13	-30.48	-57.94	-50.85	1.14	10.66	V
	3296	-54.99	-13	-41.99	-71.14	-63.53	1.32	12.01	V
									V
									V
									V
									V

Remark: Spurious emissions within 30-1000MHz were found more than 20dB below limit line.



**EDGE 850**

EDGE 850									
Channel	Frequency ( MHz )	ERP ( dBm )	Limit ( dBm )	Over Limit ( dB )	SPA Reading (dBm)	S.G. Power ( dBm )	TX Cable loss ( dB )	TX Antenna Gain (dBi)	Polarization (H/V)
Middle	1672	-61.07	-13	-48.07	-71.23	-66.75	0.93	8.75	H
	2509	-56.81	-13	-43.81	-71.1	-64.22	1.15	10.71	H
	3344	-55.64	-13	-42.64	-71.19	-64.28	1.33	12.13	H
									H
									H
									H
									H
	1672	-59.96	-13	-46.96	-69.49	-65.64	0.93	8.75	V
	2509	-55.40	-13	-42.40	-69.89	-62.81	1.15	10.71	V
	3344	-55.24	-13	-42.24	-71.24	-63.88	1.33	12.13	V
									V
									V
									V
									V

Remark: Spurious emissions within 30-1000MHz were found more than 20dB below limit line.



**WCDMA 850**

WCDMA 850									
Channel	Frequency ( MHz )	ERP ( dBm )	Limit ( dBm )	Over Limit ( dB )	SPA Reading (dBm)	S.G. Power ( dBm )	TX Cable loss ( dB )	TX Antenna Gain (dBi)	Polarization (H/V)
Middle	1672	-60.89	-13	-47.89	-71.05	-66.57	0.93	8.75	H
	2509	-56.95	-13	-43.95	-71.24	-64.36	1.15	10.71	H
	3345	-55.58	-13	-42.58	-71.12	-64.23	1.33	12.13	H
									H
									H
									H
									H
	1672	-61.72	-13	-48.72	-71.25	-67.40	0.93	8.75	V
	2509	-56.85	-13	-43.85	-71.34	-64.26	1.15	10.71	V
	3345	-54.95	-13	-41.95	-70.95	-63.60	1.33	12.13	V
									V
									V
									V
									V

Remark: Spurious emissions within 30-1000MHz were found more than 20dB below limit line.



**WCDMA 1700**

WCDMA 1700									
Channel	Frequency ( MHz )	EIRP ( dBm )	Limit ( dBm )	Over Limit ( dB )	SPA Reading (dBm)	S.G. Power ( dBm )	TX Cable loss ( dB )	TX Antenna Gain (dBi)	Polarization (H/V)
Lowest	3424	-54.07	-13	-41.07	-70.42	-65.04	1.35	12.32	H
	5137	-48.64	-13	-35.64	-70.36	-59.79	1.65	12.79	H
	6849	-44.06	-13	-31.06	-69.59	-54.43	1.74	12.11	H
									H
									H
									H
									H
	3424	-53.43	-13	-40.43	-70.2	-64.40	1.35	12.32	V
	5137	-48.74	-13	-35.74	-70.21	-59.89	1.65	12.79	V
	6849	-44.83	-13	-31.83	-69.96	-55.20	1.74	12.11	V
									V
									V
									V
									V
Middle	3465	-53.95	-13	-40.95	-70.7	-65.01	1.35	12.42	H
	5197	-48.50	-13	-35.50	-70.27	-59.71	1.66	12.88	H
	6930	-43.90	-13	-30.90	-69.83	-54.17	1.73	12.00	H
									H
									H
									H
									H
	3465	-53.55	-13	-40.55	-70.69	-64.61	1.35	12.42	V
	5197	-48.67	-13	-35.67	-70.27	-59.88	1.66	12.88	V
	6930	-44.39	-13	-31.39	-69.87	-54.66	1.73	12.00	V
									V
									V
									V
									V



Highest	3505	-53.55	-13	-40.55	-70.66	-64.69	1.36	12.50	H
	5257	-48.55	-13	-35.55	-70.53	-59.83	1.68	12.96	H
	7010	-43.52	-13	-30.52	-69.83	-53.68	1.73	11.88	H
									H
									H
									H
									H
	3505	-52.69	-13	-39.69	-70.14	-63.83	1.36	12.50	V
	5257	-48.54	-13	-35.54	-70.29	-59.82	1.68	12.96	V
	7010	-43.92	-13	-30.92	-69.75	-54.08	1.73	11.88	V
									V
									V
									V
									V

Remark: Spurious emissions within 30-1000MHz were found more than 20dB below limit line.



**GPRS 1900**

GPRS 1900									
Channel	Frequency ( MHz )	EIRP ( dBm )	Limit ( dBm )	Over Limit ( dB )	SPA Reading (dBm)	S.G. Power ( dBm )	TX Cable loss ( dB )	TX Antenna Gain (dBi)	Polarization (H/V)
Highest	3819	-52.21	-13	-39.21	-70.81	-63.46	1.44	12.69	H
	5729	-45.55	-13	-32.55	-69.08	-57.12	1.73	13.30	H
	7639	-43.52	-13	-30.52	-69.57	-52.64	2.01	11.13	H
									H
									H
									H
									H
	3819	-51.75	-13	-38.75	-70.59	-63.00	1.44	12.69	V
	5729	-46.66	-13	-33.66	-69.55	-58.23	1.73	13.30	V
	7639	-44.10	-13	-31.10	-70.06	-53.22	2.01	11.13	V
									V
									V
									V
									V

Remark: Spurious emissions within 30-1000MHz were found more than 20dB below limit line.



**EDGE1900**

EDGE 1900									
Channel	Frequency ( MHz )	EIRP ( dBm )	Limit ( dBm )	Over Limit ( dB )	SPA Reading (dBm)	S.G. Power ( dBm )	TX Cable loss ( dB )	TX Antenna Gain (dBi)	Polarization (H/V)
Middle	3760	-52.48	-13	-39.48	-70.9	-63.71	1.43	12.66	H
	5640	-46.65	-13	-33.65	-69.75	-58.22	1.73	13.30	H
	7520	-43.39	-13	-30.39	-69.9	-52.50	1.99	11.10	H
									H
									H
									H
									H
	3760	-52.09	-13	-39.09	-70.73	-63.32	1.43	12.66	V
	5640	-46.80	-13	-33.80	-69.49	-58.37	1.73	13.30	V
	7520	-43.69	-13	-30.69	-70.16	-52.80	1.99	11.10	V
									V
									V
									V
									V
								V	

Remark: Spurious emissions within 30-1000MHz were found more than 20dB below limit line.



**WCDMA 1900**

WCDMA 1900									
Channel	Frequency ( MHz )	EIRP ( dBm )	Limit ( dBm )	Over Limit ( dB )	SPA Reading (dBm)	S.G. Power ( dBm )	TX Cable loss ( dB )	TX Antenna Gain (dBi)	Polarization (H/V)
Lowest	3704	-51.96	-13	-38.96	-70.19	-63.17	1.41	12.62	H
	5557	-46.97	-13	-33.97	-70.01	-58.53	1.74	13.30	H
	7409	-43.39	-13	-30.39	-70.43	-52.69	1.94	11.25	H
									H
									H
									H
									H
	3704	-52.05	-13	-39.05	-70.43	-63.26	1.41	12.62	V
	5557	-47.45	-13	-34.45	-70.04	-59.01	1.74	13.30	V
	7409	-43.46	-13	-30.46	-70.35	-52.76	1.94	11.25	V
									V
									V
									V
									V
								V	

Remark: Spurious emissions within 30-1000MHz were found more than 20dB below limit line.



**CDMA2000 (BC0 1xRTT)**

CDMA2000 BC0									
Channel	Frequency ( MHz )	ERP ( dBm )	Limit ( dBm )	Over Limit ( dB )	SPA Reading (dBm)	S.G. Power ( dBm )	TX Cable loss ( dB )	TX Antenna Gain (dBi)	Polarization (H/V)
Lowest	1649	-58.95	-13	-45.95	-72.43	-64.55	0.92	8.67	H
	2474	-51.89	-13	-38.89	-70.2	-59.26	1.14	10.66	H
	3298	-53.72	-13	-40.72	-73.87	-62.26	1.32	12.02	H
									H
									H
									H
									H
	1649	-59.21	-13	-46.21	-72.16	-64.81	0.92	8.67	V
	2474	-51.80	-13	-38.80	-70.26	-59.17	1.14	10.66	V
	3298	-53.38	-13	-40.38	-74	-61.92	1.32	12.02	V
									V
									V
									V
									V

Remark: Spurious emissions within 30-1000MHz were found more than 20dB below limit line.



**CDMA2000 (BC0 EVDO)**

CDMA2000 BC0									
Channel	Frequency ( MHz )	ERP ( dBm )	Limit ( dBm )	Over Limit ( dB )	SPA Reading (dBm)	S.G. Power ( dBm )	TX Cable loss ( dB )	TX Antenna Gain (dBi)	Polarization (H/V)
Middle	1673	-59.52	-13	-46.52	-73.07	-65.20	0.93	8.76	H
	2509	-55.44	-13	-42.44	-73.78	-62.85	1.15	10.71	H
	3346	-53.89	-13	-40.89	-73.92	-62.54	1.33	12.13	H
									H
									H
									H
									H
	1673	-59.90	-13	-46.90	-72.82	-65.58	0.93	8.76	V
	2509	-55.51	-13	-42.51	-74.05	-62.92	1.15	10.71	V
	3346	-53.46	-13	-40.46	-73.94	-62.11	1.33	12.13	V
									V
									V
									V
									V

Remark: Spurious emissions within 30-1000MHz were found more than 20dB below limit line.



**CDMA2000 (BC1 1xRTT)**

CDMA2000 BC1									
Channel	Frequency ( MHz )	ERP ( dBm )	Limit ( dBm )	Over Limit ( dB )	SPA Reading (dBm)	S.G. Power ( dBm )	TX Cable loss ( dB )	TX Antenna Gain (dBi)	Polarization (H/V)
Lowest	3702	-51.72	-13	-38.72	-74.48	-62.93	1.41	12.62	H
	5553	-46.83	-13	-33.83	-74.54	-58.39	1.74	13.30	H
	7405	-42.64	-13	-29.64	-73.55	-51.95	1.94	11.25	H
									H
									H
									H
									H
	3702	-51.50	-13	-38.50	-74.41	-62.71	1.41	12.62	V
	5553	-47.76	-13	-34.76	-75	-59.32	1.74	13.30	V
	7405	-42.87	-13	-29.87	-73.63	-52.18	1.94	11.25	V
									V
									V
									V
									V

Remark: Spurious emissions within 30-1000MHz were found more than 20dB below limit line.



**CDMA2000 (BC1 EVDO)**

CDMA2000 BC1									
Channel	Frequency ( MHz )	ERP ( dBm )	Limit ( dBm )	Over Limit ( dB )	SPA Reading (dBm)	S.G. Power ( dBm )	TX Cable loss ( dB )	TX Antenna Gain (dBi)	Polarization (H/V)
Lowest	3702	-50.96	-13	-37.96	-73.72	-62.17	1.41	12.62	H
	5553	-46.72	-13	-33.72	-74.43	-58.28	1.74	13.30	H
	7405	-42.43	-13	-29.43	-73.34	-51.74	1.94	11.25	H
									H
									H
									H
									H
	3702	-51.62	-13	-38.62	-74.53	-62.83	1.41	12.62	V
	5553	-47.61	-13	-34.61	-74.85	-59.17	1.74	13.30	V
	7405	-42.72	-13	-29.72	-73.48	-52.03	1.94	11.25	V
									V
									V
									V
									V

Remark: Spurious emissions within 30-1000MHz were found more than 20dB below limit line.



<WPC Mode>

**EDGE1900**

EDGE 1900									
Channel	Frequency ( MHz )	EIRP ( dBm )	Limit ( dBm )	Over Limit ( dB )	SPA Reading (dBm)	S.G. Power ( dBm )	TX Cable loss ( dB )	TX Antenna Gain (dBi)	Polarization (H/V)
Middle	3760	-51.63	-13	-38.63	-70.06	-62.86	1.43	12.66	H
	5640	-46.95	-13	-33.95	-70.05	-58.52	1.73	13.30	H
	7520	-44.55	-13	-31.55	-71.06	-53.66	1.99	11.10	H
									H
									H
									H
									H
	3760	-51.81	-13	-38.81	-70.45	-63.04	1.43	12.66	V
	5640	-47.35	-13	-34.35	-70.04	-58.92	1.73	13.30	V
	7520	-44.80	-13	-31.80	-71.26	-53.91	1.99	11.10	V
									V
									V
									V
									V

Remark: Spurious emissions within 30-1000MHz were found more than 20dB below limit line.

————THE END————