



FCC RADIO TEST REPORT

FCC ID : IHDT56YJ2
Equipment : Mobile Cellular Phone
Brand Name : Motorola
Model Name : XT2061-3
Applicant : Motorola Mobility, LLC
222 W Merchandise Mart Plaza, Suite
1800, Chicago, IL 60654, United States
Manufacturer : Motorola Mobility, LLC
222 W Merchandise Mart Plaza, Suite
1800, Chicago, IL 60654, United States
Standard : FCC Part 15 Subpart C §15.247

The product was received on Dec. 06, 2019 and testing was started from Feb. 13, 2020 and completed on Feb. 24, 2020. We, SPORTON INTERNATIONAL INC., EMC & Wireless Communications Laboratory, would like to declare that the tested sample has been evaluated in accordance with the test procedures and has been in compliance with the applicable technical standards.

The report must not be used by the client to claim product certification, approval, or endorsement by TAF or any agency of government.

The test results in this variant report apply exclusively to the tested model / sample. Without written approval of SPORTON INTERNATIONAL INC. EMC & Wireless Communications Laboratory, the test report shall not be reproduced except in full.

Louis Wu

Approved by: Louis Wu

SPORTON INTERNATIONAL INC. EMC & Wireless Communications Laboratory
No. 52, Huaya 1st Rd., Guishan Dist., Taoyuan City, Taiwan (R.O.C.)



Table of Contents

History of this test report.....	3
Summary of Test Result.....	4
1 General Description	5
1.1 Product Feature of Equipment Under Test.....	5
1.2 Product Specification of Equipment Under Test.....	6
1.3 Modification of EUT	7
1.4 Testing Location	7
1.5 Applicable Standards.....	7
2 Test Configuration of Equipment Under Test	8
2.1 Carrier Frequency and Channel	8
2.2 Test Mode.....	9
2.3 Connection Diagram of Test System.....	10
2.4 Support Unit used in test configuration and system	10
2.5 EUT Operation Test Setup	10
3 Test Result	11
3.1 Output Power Measurement.....	11
3.2 Radiated Band Edges and Spurious Emission Measurement	12
3.3 Antenna Requirements	16
4 List of Measuring Equipment.....	18
5 Uncertainty of Evaluation	20
Appendix A. Conducted Test Results	
Appendix B. Radiated Spurious Emission	
Appendix C. Radiated Spurious Emission Plots	
Appendix D. Duty Cycle Plots	



Summary of Test Result

Report Clause	Ref Std. Clause	Test Items	Result (PASS/FAIL)	Remark
-	15.247(a)(2)	6dB Bandwidth	Not Required	-
-	2.1049	99% Occupied Bandwidth	Not Required	-
3.1	15.247(b)	Power Output Measurement	Pass	-
-	15.247(e)	Power Spectral Density	Not Required	-
-	15.247(d)	Conducted Band Edges	Not Required	-
		Conducted Spurious Emission	Not Required	-
3.2	15.247(d)	Radiated Band Edges and Radiated Spurious Emission	Pass	Under limit 5.42 dB at 2483.530 MHz
-	15.207	AC Conducted Emission	Not Required	-
3.3	15.203 & 15.247(b)	Antenna Requirement	Pass	-

Remark:

1. Not required means after assessing, test items are not necessary to carry out.
2. This is a variant report which can be referred Product Equality Declaration. All the test cases were performed on original report which can be referred to Sporton Report Number FR9D0635C. Based on the original report, only worst case was verified.

Declaration of Conformity:

The test results with all measurement uncertainty excluded are presented in accordance with the regulation limits or requirements declared by manufacturers.

Comments and Explanations:

The declared of product specification for EUT presented in the report are provided by the manufacturer, and the manufacturer takes all the responsibilities for the accuracy of product specification.

Reviewed by: Wii Chang

Report Producer: Ann Lee



1 General Description

1.1 Product Feature of Equipment Under Test

Product Feature	
Equipment	Mobile Cellular Phone
Brand Name	Motorola
Model Name	XT2061-3
FCC ID	IHDT56YJ2
IMEI Code	Conducted : IMEI: 359124100005862 Radiation : IMEI: 359124100005433
EUT supports Radios application	CDMA/EV-DO/GSM/EGPRS/WCDMA/HSPA/LTE/5G NR/ GNSS/NFC/WPC WLAN 11b/g/n HT20 WLAN 11a/n HT20/HT40 WLAN 11ac VHT20/VHT40/VHT80 WLAN 11ax HE20/HE40/HE80 Bluetooth BR/EDR/LE
HW Version	DVT2
EUT Stage	Identical Prototype

Remark: The above EUT's information was declared by manufacturer.

Accessory List	
AC Adapter 1	Brand Name : Motorola
	Model Name : SC-51 (SA18C30116)
	Manufacturer : Chenyang
AC Adapter 2	Brand Name : Motorola
	Model Name : SC-51 (SA18C62985)
	Manufacturer : Acbel
Battery	Brand Name : ATL
	Model Name : LW50
USB Cable 1	Brand Name : Motorola
	Model Name : SC18C24367
	Manufacturer : Saibao
USB Cable 2	Brand Name : Motorola
	Model Name : SC18C24368
	Manufacturer : Luxshare

1.2 Product Specification of Equipment Under Test

Standards-related Product Specification										
Tx/Rx Channel Frequency Range	2412 MHz ~ 2462 MHz									
Maximum Output Power to antenna <CDD Mode>	<Ant. 1> 802.11b : 20.60 dBm (0.1148 W) 802.11g : 20.10 dBm (0.1023 W) 802.11n HT20 : 19.90 dBm (0.0977 W) 802.11ax HE20 : 20.60 dBm (0.1148 W) 802.11ax HE40 : 18.40 dBm (0.0692 W) <Ant. 2> 802.11b : 20.40 dBm (0.1096 W) 802.11g : 20.10 dBm (0.1023 W) 802.11n HT20 : 20.10 dBm (0.1023 W) 802.11ax HE20 : 20.40 dBm (0.1096 W) 802.11ax HE40 : 18.40 dBm (0.0692 W) MIMO <Ant. 1+2> 802.11b : 23.53 dBm (0.2254 W) 802.11g : 23.03 dBm (0.2009 W) 802.11n HT20 : 22.92 dBm (0.1959 W) 802.11ax HE20 : 23.42 dBm (0.2198 W) 802.11ax HE40 : 21.63 dBm (0.1455 W)									
Maximum Output Power to antenna <TXBF Mode>	MIMO <Ant. 1+2> 802.11ax HE20 : 21.48 dBm (0.1406 W)									
Antenna Type / Gain	<Ant. 1> : Fixed Internal type with gain -2.50 dBi <Ant. 2> : Fixed Internal type with gain -6.60 dBi									
Type of Modulation	802.11b : DSSS (DBPSK / DQPSK / CCK) 802.11g/n : OFDM (BPSK / QPSK / 16QAM / 64QAM) 802.11ax : OFDM (BPSK / QPSK / 16QAM / 64QAM / 256 QAM / 1024 QAM)									
Antenna Function Description	<table border="1"> <thead> <tr> <th></th> <th>Ant. 1</th> <th>Ant. 2</th> </tr> </thead> <tbody> <tr> <td>802.11 b/g/n/ax</td> <td>√</td> <td>√</td> </tr> <tr> <td>802.11 b/g/n/ax MIMO</td> <td>√</td> <td>√</td> </tr> </tbody> </table>		Ant. 1	Ant. 2	802.11 b/g/n/ax	√	√	802.11 b/g/n/ax MIMO	√	√
	Ant. 1	Ant. 2								
802.11 b/g/n/ax	√	√								
802.11 b/g/n/ax MIMO	√	√								

Remark: MIMO Ant. 1+2 is a calculated result from sum of the power MIMO Ant. 1 and MIMO Ant. 2.



1.3 Modification of EUT

No modifications are made to the EUT during all test items.

1.4 Testing Location

Test Site	SPORTON INTERNATIONAL INC. EMC & Wireless Communications Laboratory
Test Site Location	No.52, Huaya 1st Rd., Guishan Dist., Taoyuan City, Taiwan (R.O.C.) TEL: +886-3-327-3456 FAX: +886-3-328-4978
Test Site No.	Sporton Site No.
	TH05-HY

Note: The test site complies with ANSI C63.4 2014 requirement.

Test Site	SPORTON INTERNATIONAL INC. EMC & Wireless Communications Laboratory
Test Site Location	No.58, Aly. 75, Ln. 564, Wenhua 3rd, Rd., Guishan Dist., Taoyuan City, Taiwan (R.O.C.) TEL: +886-3-327-0868 FAX: +886-3-327-0855
Test Site No.	Sporton Site No.
	03CH15-HY

Note: The test site complies with ANSI C63.4 2014 requirement.

FCC designation No.: TW1190 and TW0007

1.5 Applicable Standards

According to the specifications of the manufacturer, the EUT must comply with the requirements of the following standards:

- ♦ FCC Part 15 Subpart C §15.247
- ♦ FCC KDB Publication No. 558074 D01 DTS Meas. Guidance v05r02
- ♦ FCC KDB 414788 D01 Radiated Test Site v01r01.
- ♦ FCC KDB 662911 D01 Multiple Transmitter Output v02r01.
- ♦ ANSI C63.10-2013

Remark:

1. All test items were verified and recorded according to the standards and without any deviation during the test.
2. This EUT has also been tested and complied with the requirements of FCC Part 15, Subpart B, recorded in a separate test report.



2 Test Configuration of Equipment Under Test

- a. The EUT has been associated with peripherals and configuration operated in a manner tended to maximize its emission characteristics in a typical application. Frequency range investigated:, radiation emission (9 kHz to the 10th harmonic of the highest fundamental frequency or to 40 GHz, whichever is lower). For radiated measurement, pre-scanned in three orthogonal panels, X, Y, Z. The worst cases (Y Plane for 802.11ax Mode; Z plane for 802.11 b/n Mode) were recorded in this report.

2.1 Carrier Frequency and Channel

Frequency Band	Channel	Freq. (MHz)	Channel	Freq. (MHz)
2400-2483.5 MHz	1	2412	7	2442
	2	2417	8	2447
	3	2422	9	2452
	4	2427	10	2457
	5	2432	11	2462
	6	2437		



2.2 Test Mode

Final test modes are considering the modulation and worse data rates as below table.

CDD Mode

Modulation	Data Rate
802.11b	1 Mbps
802.11g	6 Mbps
802.11n HT20	MCS0
802.11ax HE20	MCS0
802.11ax HE40	MCS0

TXBF Mode

Modulation	Data Rate
802.11ax HE20	MCS0

Ch. #	2400-2483.5 MHz	
	802.11b	802.11n HT20
Low	-	-
Middle	-	-
High	11	11

Ch. #	2400-2483.5 MHz	
	802.11ax HE20	802.11ax HE40
Low	01	-
Middle	-	-
High	-	09

Remark:

1. For radiation spurious emission, the final modulation and the worst data rate was reference the max RF conducted power.
2. For Radiated Test Cases, the tests were performed with Adapter 1 and USB Cable 1.

2.3 Connection Diagram of Test System

<WLAN Tx Mode>

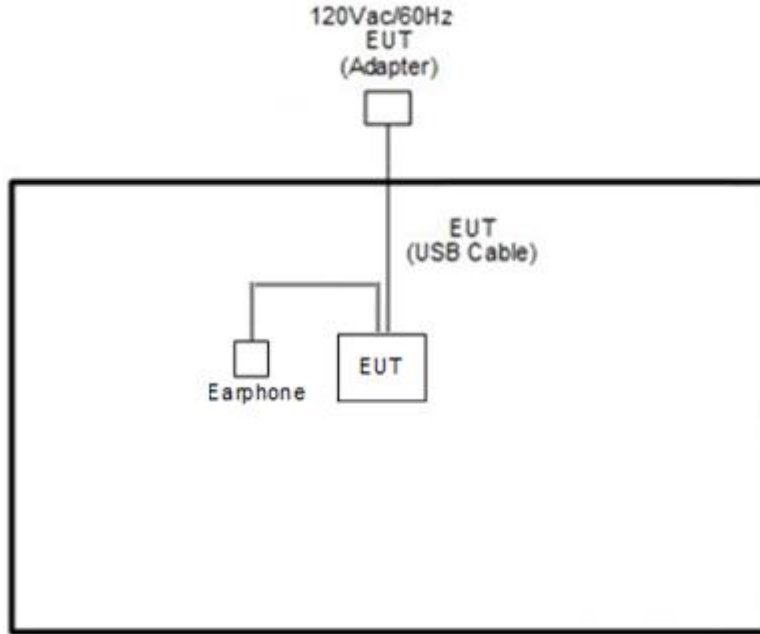

2.4 Support Unit used in test configuration and system

Item	Equipment	Trade Name	Model Name	FCC ID	Data Cable	Power Cord
1.	Earphone	Moto	NASH38C16618	N/A	Unshielded, 1.0 m	N/A

2.5 EUT Operation Test Setup

The RF test items, utility “QRCT V4.0.00142.0” was installed in Notebook which was programmed in order to make the EUT get into the engineering modes to provide channel selection, power level, data rate and the application type and for continuous transmitting signals.

For TXBF mode, the modulation modes and data rates manipulated by the command lines in the engineering program made the EUT link to another EUT by power under the normal operation. The “QRCT V4.0.00142.0” software tool was used to enable the EUT to transmit signals continuously.

3 Test Result

3.1 Output Power Measurement

3.1.1 Limit of Output Power

For systems using digital modulation in the 2400-2483.5MHz, the limit for output power is 30dBm. If transmitting antenna with directional gain greater than 6dBi is used, the output power from the intentional radiator shall be reduced below the above stated value by the amount in dB that the directional gain of the antenna exceeds 6 dBi. In case of point-to-point operation, the limit has to be reduced by 1dB for every 3dB that the directional gain of the antenna exceeds 6dBi.

3.1.2 Measuring Instruments

See list of measuring equipment of this test report.

3.1.3 Test Procedures

1. For Peak Power, the testing follows ANSI C63.10 Section 11.9.1.3 PKPM1
2. For Average Power, the testing follows ANSI C63.10 Section 11.9.2.3.2 Method AVGPM-G
3. The RF output of EUT was connected to the power meter by RF cable and attenuator. The path loss was compensated to the results for each measurement.
4. Set to the maximum power setting and enable the EUT transmit continuously.
5. Measure the conducted output power and record the results in the test report.
6. For MIMO mode, calculation method follows FCC KDB 662911 D01 Multiple Transmitter Output v02r01.

3.1.4 Test Setup

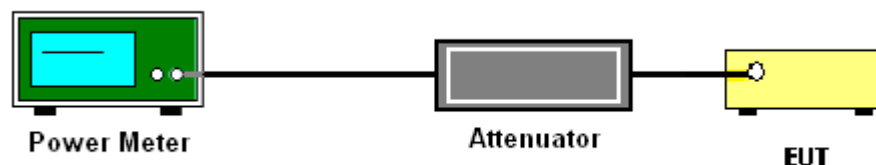

3.1.5 Test Result of Peak Output Power (Reporting Only)

Please refer to Appendix A.

3.1.6 Test Result of Average Output Power

Please refer to Appendix A.



3.2 Radiated Band Edges and Spurious Emission Measurement

3.2.1 Limit of Radiated band edge and Spurious Emission Measurement

In any 100 kHz bandwidth outside the intentional radiator frequency band, all harmonics/spurious must be at least 20 dB below the highest emission level within the authorized band. If the output power of this device was measured by spectrum analyzer, the attenuation under this paragraph shall be 30 dB instead of 20 dB. In addition, radiated emissions which fall in the restricted bands must also comply with the limits as below.

Frequency (MHz)	Field Strength (microvolts/meter)	Measurement Distance (meters)
0.009 – 0.490	2400/F(kHz)	300
0.490 – 1.705	24000/F(kHz)	30
1.705 – 30.0	30	30
30 – 88	100	3
88 – 216	150	3
216 - 960	200	3
Above 960	500	3

3.2.2 Measuring Instruments

See list of measuring equipment of this test report.

**3.2.3 Test Procedures**

1. The testing follows the ANSI C63.10 Section 11.12.1 Radiated emission measurements
2. The EUT was arranged to its worst case and then tune the antenna tower (from 1 m to 4 m) and turntable (from 0 degree to 360 degrees) to find the maximum reading. A pre-amp and a high pass filter are used for the test in order to get better signal level.
3. The EUT was placed on a turntable with 0.8 meter for frequency below 1GHz and 1.5 meter for frequency above 1GHz respectively above ground.
4. The EUT was set 3 meters from the interference receiving antenna, which was mounted on the top of a variable height antenna tower.
5. Corrected Reading: Antenna Factor + Cable Loss + Read Level - Preamp Factor = Level
6. For testing below 1GHz, if the emission level of the EUT in peak mode was 3 dB lower than the limit specified, then peak values of EUT will be reported, otherwise, the emissions will be repeated one by one using the CISPR quasi-peak method and reported.
7. For testing above 1GHz, the emission level of the EUT in peak mode was 20dB lower than average limit (that means the emission level in average mode also complies with the limit in average mode), then peak values of EUT will be reported, otherwise, the emissions will be measured in average mode again and reported.
8. Use the following spectrum analyzer settings:
 - (1) Span shall wide enough to fully capture the emission being measured;
 - (2) Set RBW=100 kHz for $f < 1$ GHz; $VBW \geq RBW$; Sweep = auto; Detector function = peak; Trace = max hold;
 - (3) Set RBW = 1 MHz, VBW= 3MHz for $f \geq 1$ GHz for peak measurement.
For average measurement:
 - $VBW = 10$ Hz, when duty cycle is no less than 98 percent.
 - $VBW \geq 1/T$, when duty cycle is less than 98 percent where T is the minimum transmission duration over which the transmitter is on and is transmitting at its maximum power control level for the tested mode of operation.

3.2.4 Test Setup

For radiated emissions below 30MHz

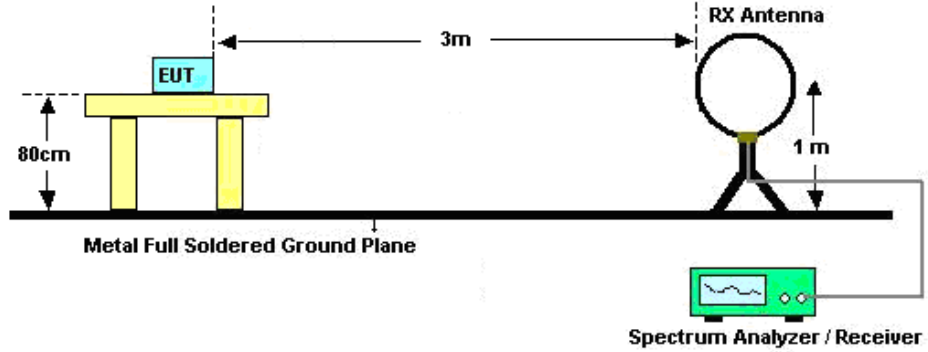

For radiated emissions from 30MHz to 1GHz

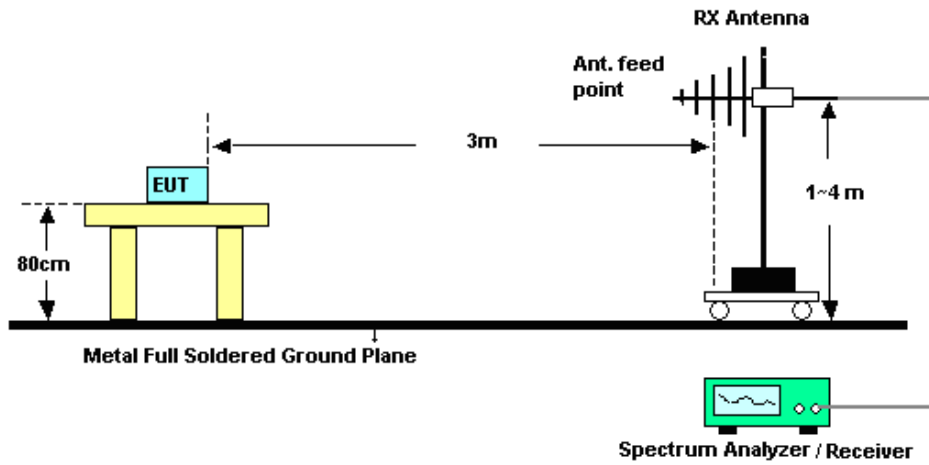

For radiated emissions above 1GHz

<CDD Mode>

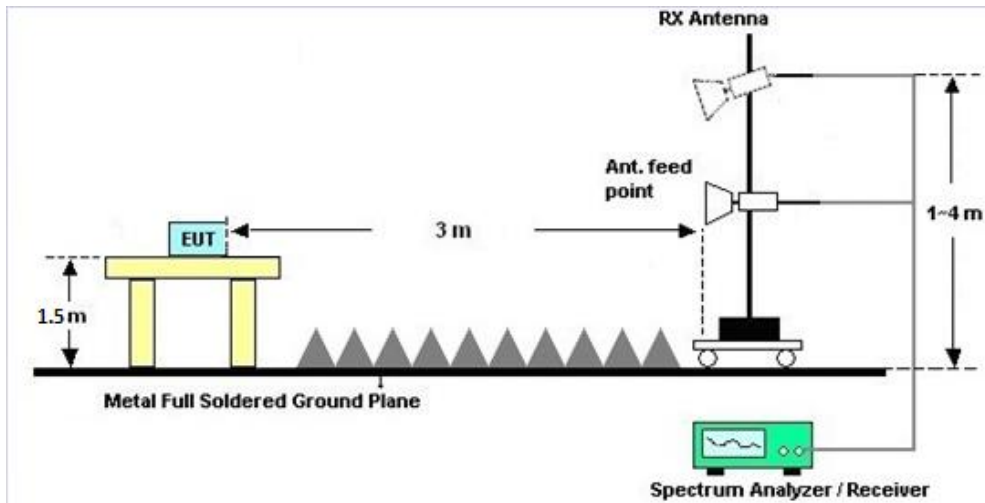

3.2.5 Test Results of Radiated Spurious Emissions (9kHz ~ 30MHz)

The low frequency, which started from 9 kHz to 30MHz, was pre-scanned and the result which was 20dB lower than the limit line was not reported.

There is a comparison data of both open-field test site and alternative test site - semi-Anechoic chamber according to 414788 D01 Radiated Test Site v01r01, and the result came out very similar.

3.2.6 Test Result of Radiated Spurious at Band Edges

Please refer to Appendix B and C.

3.2.7 Duty Cycle

Please refer to Appendix D.

3.2.8 Test Result of Radiated Spurious Emission (30MHz ~ 10th Harmonic)

Please refer to Appendix B and C.



3.3 Antenna Requirements

3.3.1 Standard Applicable

If directional gain of transmitting Antennas is greater than 6dBi, the power shall be reduced by the same level in dB comparing to gain minus 6dBi. The use of a permanently attached Antenna or of an Antenna that uses a unique coupling to the intentional radiator shall be considered sufficient to comply with the rule.

3.3.2 Antenna Anti-Replacement Construction

An embedded-in antenna design is used.

3.3.3 Antenna Gain

<CDD Modes >

FCC KDB 662911 D01 Multiple Transmitter Output v02r01

For CDD transmissions, directional gain is calculated as

Directional gain = G_{ANT} + Array Gain, where Array Gain is as follows.

For power spectral density (PSD) measurements on all devices,

Array Gain = $10 \log(N_{ANT}/N_{SS}=1)$ dB.

For power measurements on IEEE 802.11 devices,

Array Gain = 0 dB (i.e., no array gain) for $N_{ANT} \leq 4$.

Directional gain may be calculated by using the formulas applicable to equal gain antennas with G_{ANT} set equal to the gain of the antenna having the highest gain;

The EUT supports CDD mode.

For power, the directional gain G_{ANT} is set equal to the antenna having the highest gain, i.e., F)2)f)i).

For PSD, the directional gain calculation is following F)2)f)ii) of KDB 662911 D01 v02r01.

The power and PSD limit should be modified if the directional gain of EUT is over 6 dBi,

The directional gain "DG" is calculated as following table.

<CDD Modes>						
			DG	DG	Power	PSD
	Ant. 1	Ant. 2	for	for	Limit	Limit
	(dBi)	(dBi)	Power	PSD	Reduction	Reduction
	(dBi)	(dBi)	(dBi)	(dBi)	(dB)	(dB)
2.4 GHz	-2.50	-6.60	-2.50	-1.30	0.00	0.00

$Power\ Limit\ Reduction = DG(Power) - 6dBi, (min = 0)$

$PSD\ Limit\ Reduction = DG(PSD) - 6dBi, (min = 0)$

TXBF modes

FCC KDB 662911 D01 Multiple Transmitter Output v02r01

For CDD transmissions, directional gain is calculated as

$$DirectionalGain = 10 \cdot \log \left[\frac{\sum_{j=1}^{N_{SS}} \left\{ \sum_{k=1}^{N_{ANT}} g_{j,k} \right\}^2}{N_{ANT}} \right]$$

where

Each antenna is driven by no more than one spatial stream;

N_{SS} = the number of independent spatial streams of data;

N_{ANT} = the total number of antennas

$g_{j,k} = 10^{G_k / 20}$ if the k th antenna is being fed by spatial stream j , or zero if it is not;
 G_k is the gain in dBi of the k th antenna.

The EUT supports beamforming for 802.11ac modes.

The directional gain calculation is following F)2)e)ii) of KDB 662911 D01 v02r01.

The power and PSD limit should be modified if the directional gain of EUT is over 6 dBi,

The directional gain “DG” is calculated as following table.

			DG	DG	Power	PSD
			for	for	Limit	Limit
	Ant. 1	Ant. 2	Power	PSD	Reduction	Reduction
	(dBi)	(dBi)	(dBi)	(dBi)	(dB)	(dB)
2.4 GHz	-2.50	-6.60	-1.30	-1.30	0.00	0.00

Power Limit Reduction = DG(Power) – 6dBi, (min = 0)

PSD Limit Reduction = DG(PSD) – 6dBi, (min = 0)



4 List of Measuring Equipment

Instrument	Manufacturer	Model No.	Serial No.	Characteristics	Calibration Date	Test Date	Due Date	Remark
Loop Antenna	Rohde & Schwarz	HFH2-Z2	100488	9 kHz~30 MHz	Jan. 09, 2020	Feb. 21, 2020~ Feb. 24, 2020	Jan. 08, 2021	Radiation (03CH15-HY)
Bilog Antenna	TESEQ	CBL6111D&0 0800N1D01N- 06	41912&05	30MHz to 1GHz	Feb. 09, 2020	Feb. 21, 2020~ Feb. 24, 2020	Feb. 08, 2021	Radiation (03CH15-HY)
Horn Antenna	SCHWARZBE CK	BBHA 9120 D	9120D-211 4	1-18GHz	Jul. 31, 2019	Feb. 21, 2020~ Feb. 24, 2020	Jul. 30, 2020	Radiation (03CH15-HY)
SHF-EHF Horn Antenna	SCHWARZBE CK	BBHA 9170	BBHA9170 584	18GHz- 40GHz	Dec. 10, 2019	Feb. 21, 2020~ Feb. 24, 2020	Dec. 09, 2020	Radiation (03CH15-HY)
Amplifier	SONOMA	310N	363440	9kHz~1GHz	Dec. 27, 2019	Feb. 21, 2020~ Feb. 24, 2020	Dec. 26, 2020	Radiation (03CH15-HY)
Preamplifier	Jet-Power	JPA0118-55-3 03	171000180 0055007	1GHz~18GHz	Apr. 01, 2019	Feb. 21, 2020~ Feb. 24, 2020	Mar. 31, 2020	Radiation (03CH15-HY)
Preamplifier	Keysight	83017A	MY532701 95	1GHz~26.5GHz	Aug. 23, 2019	Feb. 21, 2020~ Feb. 24, 2020	Aug. 22, 2020	Radiation (03CH15-HY)
Preamplifier	EMEC	EM18G40G	060715	18GHz ~ 40GHz	Dec. 13, 2019	Feb. 21, 2020~ Feb. 24, 2020	Dec. 12, 2020	Radiation (03CH15-HY)
EMI Test Receiver	Keysight	N9038A(MXE)	MY554201 70	20MHz~8.4GHz	Mar. 08, 2019	Feb. 21, 2020~ Feb. 24, 2020	Mar. 07, 2020	Radiation (03CH15-HY)
Spectrum Analyzer	Agilent	E4446A	MY501801 36	3Hz~44GHz	Apr. 29, 2019	Feb. 21, 2020~ Feb. 24, 2020	Apr. 28, 2020	Radiation (03CH15-HY)
Antenna Mast	ChainTek	MBS-520-1	N/A	1m~4m	N/A	Feb. 21, 2020~ Feb. 24, 2020	N/A	Radiation (03CH15-HY)
Turn Table	ChainTek	T-200-S-1	N/A	0~360 Degree	N/A	Feb. 21, 2020~ Feb. 24, 2020	N/A	Radiation (03CH15-HY)
Software	Audix	E3 6.2009-8-24(k 5)	RK-00045 1	N/A	N/A	Feb. 21, 2020~ Feb. 24, 2020	N/A	Radiation (03CH15-HY)
RF Cable	HUBER + SUHNER	SUCOFLEX 104	MY36980/ 4	30M-18G	Apr. 15, 2019	Feb. 21, 2020~ Feb. 24, 2020	Apr. 14, 2020	Radiation (03CH15-HY)
RF Cable	HUBER + SUHNER	SUCOFLEX 104	MY9838/4 PE	30M-18G	Apr. 15, 2019	Feb. 21, 2020~ Feb. 24, 2020	Apr. 14, 2020	Radiation (03CH15-HY)
RF Cable	HUBER + SUHNER	SUCOFLEX 104	MY802430 /4	30M~18GHz	May 13, 2019	Feb. 21, 2020~ Feb. 24, 2020	May 12, 2020	Radiation (03CH15-HY)
RF Cable	HUBER + SUHNER	SUCOFLEX 102	505134/2	30MHz-40GHz	Feb. 26, 2019	Feb. 21, 2020~ Feb. 24, 2020	Feb. 25, 2020	Radiation (03CH15-HY)
RF Cable	HUBER + SUHNER	SUCOFLEX 102	800740/2	30MHz-40GHz	Feb. 26, 2019	Feb. 21, 2020~ Feb. 24, 2020	Feb. 25, 2020	Radiation (03CH15-HY)
Filter	Wainwright	WLK4-1000-1 530-8000-40S S	SN4	1.53G Low Pass	Jul. 04, 2019	Feb. 21, 2020~ Feb. 24, 2020	Jul. 03, 2020	Radiation (03CH15-HY)
Filter	Wainwright	WHKX12-270 0-3000-18000 -60ST	SN2	3GHz High Pass Filter	Jul. 17, 2019	Feb. 21, 2020~ Feb. 24, 2020	Jul. 14, 2020	Radiation (03CH15-HY)



Instrument	Manufacturer	Model No.	Serial No.	Characteristics	Calibration Date	Test Date	Due Date	Remark
Hygrometer	Testo	608-H2	41410069	N/A	Jun. 17, 2019	Feb. 13, 2020~ Feb. 21, 2020	Jun. 16, 2020	Conducted (TH05-HY)
Power Sensor	DARE	RPR3006W	16I00054S NO10	10MHz~6GHz	Dec. 23, 2019	Feb. 13, 2020~ Feb. 21, 2020	Dec. 22, 2020	Conducted (TH05-HY)
Signal Analyzer	Rohde & Schwarz	FSV40	101566	10Hz~40GHz	Jul. 15, 2019	Feb. 13, 2020~ Feb. 21, 2020	Jul. 14, 2020	Conducted (TH05-HY)
Switch Control Manframe	E-IUSTRUME NT	ETF-1405-0	EC190006 7	N/A	Aug. 15, 2019	Feb. 13, 2020~ Feb. 21, 2020	Aug. 14, 2020	Conducted (TH05-HY)



5 Uncertainty of Evaluation

Uncertainty of Radiated Emission Measurement (30 MHz ~ 1000 MHz)

Measuring Uncertainty for a Level of Confidence of 95% ($U = 2Uc(y)$)	5.0
---	-----

Uncertainty of Radiated Emission Measurement (1000 MHz ~ 18000 MHz)

Measuring Uncertainty for a Level of Confidence of 95% ($U = 2Uc(y)$)	5.4
---	-----

Uncertainty of Radiated Emission Measurement (18000 MHz ~ 40000 MHz)

Measuring Uncertainty for a Level of Confidence of 95% ($U = 2Uc(y)$)	5.0
---	-----

Appendix A. Test Result of Conducted Test Items**<CDD Mode>**

Test Engineer:	Kai Liao/Kathy Chen/Richard Qiu	Temperature:	21~25	°C
Test Date:	2020/2/13~2020/2/21	Relative Humidity:	51~54	%

TEST RESULTS DATA
Peak Output Power

2.4GHz Band Single Antenna																
Mod.	Data Rate	NTX	CH.	Freq. (MHz)	Peak Conducted Power (dBm)			Conducted Power Limit (dBm)		DG (dBi)		EIRP Power (dBm)		EIRP Power Limit (dBm)		Pass /Fail
					Ant1	Ant2	SUM	Ant1	Ant2	Ant1	Ant2	Ant1	Ant2	Ant1	Ant2	
11b	1Mbps	1	1	2412	22.84	22.61		30.00	30.00	-2.50	-6.60	20.34	16.01	36.00	36.00	Pass
11b	1Mbps	1	6	2437	22.76	22.49		30.00	30.00	-2.50	-6.60	20.26	15.89	36.00	36.00	Pass
11b	1Mbps	1	11	2462	22.92	22.65		30.00	30.00	-2.50	-6.60	20.42	16.05	36.00	36.00	Pass
11g	6Mbps	1	1	2412	24.90	24.40		30.00	30.00	-2.50	-6.60	22.40	17.80	36.00	36.00	Pass
11g	6Mbps	1	6	2437	26.15	24.66		30.00	30.00	-2.50	-6.60	23.65	18.06	36.00	36.00	Pass
11g	6Mbps	1	11	2462	24.84	23.90		30.00	30.00	-2.50	-6.60	22.34	17.30	36.00	36.00	Pass
HT20	MCS0	1	1	2412	23.97	23.67		30.00	30.00	-2.50	-6.60	21.47	17.07	36.00	36.00	Pass
HT20	MCS0	1	6	2437	26.07	24.74		30.00	30.00	-2.50	-6.60	23.57	18.14	36.00	36.00	Pass
HT20	MCS0	1	11	2462	24.67	23.60		30.00	30.00	-2.50	-6.60	22.17	17.00	36.00	36.00	Pass

2.4GHz Band MIMO																
Mod.	MCS0	NTX	CH.	Freq. (MHz)	Peak Conducted Power (dBm)			Conducted Power Limit (dBm)		DG (dBi)		EIRP Power (dBm)		EIRP Power Limit (dBm)		Pass /Fail
					Ant1	Ant2	SUM	Ant1	Ant2	Ant1	Ant2	Ant1	Ant2	Ant1	Ant2	
11b	1Mbps	2	1	2412	23.30	22.48	25.92	30.00		-2.50		23.42		36.00		Pass
11b	1Mbps	2	6	2437	23.26	22.40	25.86	30.00		-2.50		23.36		36.00		Pass
11b	1Mbps	2	11	2462	23.34	22.00	25.73	30.00		-2.50		23.23		36.00		Pass
11g	6Mbps	2	1	2412	25.12	23.85	27.54	30.00		-2.50		25.04		36.00		Pass
11g	6Mbps	2	6	2437	25.97	24.20	28.18	30.00		-2.50		25.68		36.00		Pass
11g	6Mbps	2	11	2462	25.25	23.48	27.46	30.00		-2.50		24.96		36.00		Pass
HT20	MCS0	2	1	2412	24.56	23.56	27.10	30.00		-2.50		24.60		36.00		Pass
HT20	MCS0	2	6	2437	25.91	24.20	28.15	30.00		-2.50		25.65		36.00		Pass
HT20	MCS0	2	11	2462	24.44	22.80	26.71	30.00		-2.50		24.21		36.00		Pass

Note: Measured power (dBm) has offset with cable loss.

TEST RESULTS DATA
Peak Output Power

2.4GHz Band Single Antenna																	
Mod.	Data Rate	N _{Tx}	CH.	Freq. (MHz)	RU Config	Peak Conducted Power (dBm)			Conducted Power Limit (dBm)		DG (dBi)		EIRP Power (dBm)		EIRP Power Limit (dBm)		Pass /Fail
						Ant1	Ant2	SUM	Ant1	Ant2	Ant1	Ant2	Ant1	Ant2	Ant1	Ant2	
HE20	MCS0	1	1	2412	Full	24.66	23.95		30.00	30.00	-2.50	-6.60	22.16	17.35	36.00	36.00	Pass
HE20	MCS0	1	1	2412	26/0	26.25	25.66		30.00	30.00	-2.50	-6.60	23.75	19.06	36.00	36.00	Pass
HE20	MCS0	1	1	2412	52/37	26.67	25.72		30.00	30.00	-2.50	-6.60	24.17	19.12	36.00	36.00	Pass
HE20	MCS0	1	1	2412	106/53	26.25	25.38		30.00	30.00	-2.50	-6.60	23.75	18.78	36.00	36.00	Pass
HE20	MCS0	1	6	2437	Full	26.78	24.86		30.00	30.00	-2.50	-6.60	24.28	18.26	36.00	36.00	Pass
HE20	MCS0	1	11	2462	Full	24.72	23.95		30.00	30.00	-2.50	-6.60	22.22	17.35	36.00	36.00	Pass
HE20	MCS0	1	11	2462	26/8	26.43	24.45		30.00	30.00	-2.50	-6.60	23.93	17.85	36.00	36.00	Pass
HE20	MCS0	1	11	2462	52/40	26.26	24.51		30.00	30.00	-2.50	-6.60	23.76	17.91	36.00	36.00	Pass
HE20	MCS0	1	11	2462	106/54	26.01	24.27		30.00	30.00	-2.50	-6.60	23.51	17.67	36.00	36.00	Pass
HE40	MCS0	1	3	2422	Full	24.56	24.06		30.00	30.00	-2.50	-6.60	22.06	17.46	36.00	36.00	Pass
HE40	MCS0	1	3	2422	242/61	26.10	25.07		30.00	30.00	-2.50	-6.60	23.60	18.47	36.00	36.00	Pass
HE40	MCS0	1	6	2437	Full	25.67	24.41		30.00	30.00	-2.50	-6.60	23.17	17.81	36.00	36.00	Pass
HE40	MCS0	1	6	2437	242/61	26.73	25.14		30.00	30.00	-2.50	-6.60	24.23	18.54	36.00	36.00	Pass
HE40	MCS0	1	9	2452	Full	23.84	23.51		30.00	30.00	-2.50	-6.60	21.34	16.91	36.00	36.00	Pass
HE40	MCS0	1	9	2452	242/62	24.50	24.01		30.00	30.00	-2.50	-6.60	22.00	17.41	36.00	36.00	Pass

2.4GHz Band MIMO																	
Mod.	Data Rate	N _{Tx}	CH.	Freq. (MHz)	RU Config	Peak Conducted Power (dBm)			Conducted Power Limit (dBm)		DG (dBi)		EIRP Power (dBm)		EIRP Power Limit (dBm)		Pass /Fail
						Ant1	Ant2	SUM	Ant1	Ant2	Ant1	Ant2	Ant1	Ant2	Ant1	Ant2	
HE20	MCS0	2	1	2412	Full	24.95	23.96	27.49	30.00		-2.50		24.99		36.00		Pass
HE20	MCS0	2	1	2412	26/0	27.06	25.40	29.32	30.00		-2.50		26.82		36.00		Pass
HE20	MCS0	2	1	2412	52/37	26.96	25.31	29.22	30.00		-2.50		26.72		36.00		Pass
HE20	MCS0	2	1	2412	106/53	26.50	24.94	28.80	30.00		-2.50		26.30		36.00		Pass
HE20	MCS0	2	6	2437	Full	26.36	24.33	28.47	30.00		-2.50		25.97		36.00		Pass
HE20	MCS0	2	11	2462	Full	24.96	22.94	27.08	30.00		-2.50		24.58		36.00		Pass
HE20	MCS0	2	11	2462	26/8	26.22	24.07	28.29	30.00		-2.50		25.79		36.00		Pass
HE20	MCS0	2	11	2462	52/40	26.02	24.29	28.25	30.00		-2.50		25.75		36.00		Pass
HE20	MCS0	2	11	2462	106/54	25.96	23.92	28.07	30.00		-2.50		25.57		36.00		Pass
HE40	MCS0	2	3	2422	Full	24.91	23.81	27.41	30.00		-2.50		24.91		36.00		Pass
HE40	MCS0	2	3	2422	242/61	26.04	25.08	28.60	30.00		-2.50		26.10		36.00		Pass
HE40	MCS0	2	6	2437	Full	25.82	24.16	28.08	30.00		-2.50		25.58		36.00		Pass
HE40	MCS0	2	6	2437	242/61	26.78	25.38	29.15	30.00		-2.50		26.65		36.00		Pass
HE40	MCS0	2	9	2452	Full	24.45	22.86	26.74	30.00		-2.50		24.24		36.00		Pass
HE40	MCS0	2	9	2452	242/62	24.14	22.66	26.47	30.00		-2.50		23.97		36.00		Pass

Note: Measured power (dBm) has offset with cable loss.

TEST RESULTS DATA
Average Output Power

2.4GHz Band Single Antenna																
Mod.	Data Rate	NTX	CH.	Freq. (MHz)	Average Conducted Power (dBm)			Conducted Power Limit (dBm)		DG (dBi)		EIRP Power (dBm)		EIRP Power Limit (dBm)		Pass /Fail
					Ant1	Ant2	SUM	Ant1	Ant2	Ant1	Ant2	Ant1	Ant2	Ant1	Ant2	
11b	1Mbps	1	1	2412	20.50	20.30		30.00	30.00	-2.50	-6.60	18.00	13.70	36.00	36.00	Pass
11b	1Mbps	1	6	2437	20.50	20.20		30.00	30.00	-2.50	-6.60	18.00	13.60	36.00	36.00	Pass
11b	1Mbps	1	11	2462	20.60	20.40		30.00	30.00	-2.50	-6.60	18.10	13.80	36.00	36.00	Pass
11g	6Mbps	1	1	2412	17.90	17.90		30.00	30.00	-2.50	-6.60	15.40	11.30	36.00	36.00	Pass
11g	6Mbps	1	6	2437	20.10	20.10		30.00	30.00	-2.50	-6.60	17.60	13.50	36.00	36.00	Pass
11g	6Mbps	1	11	2462	17.90	18.00		30.00	30.00	-2.50	-6.60	15.40	11.40	36.00	36.00	Pass
HT20	MCS0	1	1	2412	16.80	16.70		30.00	30.00	-2.50	-6.60	14.30	10.10	36.00	36.00	Pass
HT20	MCS0	1	6	2437	19.90	20.10		30.00	30.00	-2.50	-6.60	17.40	13.50	36.00	36.00	Pass
HT20	MCS0	1	11	2462	17.30	17.20		30.00	30.00	-2.50	-6.60	14.80	10.60	36.00	36.00	Pass

2.4GHz Band MIMO																
Mod.	MCS0	NTX	CH.	Freq. (MHz)	Average Conducted Power (dBm)			Conducted Power Limit (dBm)		DG (dBi)		EIRP Power (dBm)		EIRP Power Limit (dBm)		Pass /Fail
					Ant1	Ant2	SUM	Ant1	Ant2	Ant1	Ant2	Ant1	Ant2	Ant1	Ant2	
11b	1Mbps	2	1	2412	20.90	20.10	23.53	30.00		-2.50		21.03		36.00		Pass
11b	1Mbps	2	6	2437	20.90	20.10	23.53	30.00		-2.50		21.03		36.00		Pass
11b	1Mbps	2	11	2462	20.90	19.80	23.40	30.00		-2.50		20.90		36.00		Pass
11g	6Mbps	2	1	2412	18.30	17.30	20.84	30.00		-2.50		18.34		36.00		Pass
11g	6Mbps	2	6	2437	20.40	19.60	23.03	30.00		-2.50		20.53		36.00		Pass
11g	6Mbps	2	11	2462	18.70	17.60	21.20	30.00		-2.50		18.70		36.00		Pass
HT20	MCS0	2	1	2412	17.30	16.60	19.97	30.00		-2.50		17.47		36.00		Pass
HT20	MCS0	2	6	2437	20.20	19.60	22.92	30.00		-2.50		20.42		36.00		Pass
HT20	MCS0	2	11	2462	17.40	16.40	19.94	30.00		-2.50		17.44		36.00		Pass

Note: Measured power (dBm) has offset with cable loss.

TEST RESULTS DATA
Average Output Power

2.4GHz Band Single Antenna																	
Mod.	Data Rate	NTx	CH.	Freq. (MHz)	RU Config	Average Conducted Power (dBm)			Conducted Power Limit (dBm)		DG (dBi)		EIRP Power (dBm)		EIRP Power Limit (dBm)		Pass /Fail
						Ant1	Ant2	SUM	Ant1	Ant2	Ant1	Ant2	Ant1	Ant2	Ant1	Ant2	
HE20	MCS0	1	1	2412	Full	16.30	16.30		30.00	30.00	-2.50	-6.60	13.80	9.70	36.00	36.00	Pass
HE20	MCS0	1	1	2412	26/0	16.20	16.20		30.00	30.00	-2.50	-6.60	13.70	9.60	36.00	36.00	Pass
HE20	MCS0	1	1	2412	52/37	16.20	16.20		30.00	30.00	-2.50	-6.60	13.70	9.60	36.00	36.00	Pass
HE20	MCS0	1	1	2412	106/53	16.20	16.10		30.00	30.00	-2.50	-6.60	13.70	9.50	36.00	36.00	Pass
HE20	MCS0	1	6	2437	Full	20.60	20.40		30.00	30.00	-2.50	-6.60	18.10	13.80	36.00	36.00	Pass
HE20	MCS0	1	11	2462	Full	16.50	16.70		30.00	30.00	-2.50	-6.60	14.00	10.10	36.00	36.00	Pass
HE20	MCS0	1	11	2462	26/8	16.40	16.40		30.00	30.00	-2.50	-6.60	13.90	9.80	36.00	36.00	Pass
HE20	MCS0	1	11	2462	52/40	16.30	16.40		30.00	30.00	-2.50	-6.60	13.80	9.80	36.00	36.00	Pass
HE20	MCS0	1	11	2462	106/54	16.40	16.40		30.00	30.00	-2.50	-6.60	13.90	9.80	36.00	36.00	Pass
HE40	MCS0	1	3	2422	Full	16.70	16.80		30.00	30.00	-2.50	-6.60	14.20	10.20	36.00	36.00	Pass
HE40	MCS0	1	3	2422	242/61	14.90	14.50		30.00	30.00	-2.50	-6.60	12.40	7.90	36.00	36.00	Pass
HE40	MCS0	1	6	2437	Full	18.40	18.40		30.00	30.00	-2.50	-6.60	15.90	11.80	36.00	36.00	Pass
HE40	MCS0	1	6	2437	242/61	18.20	18.30		30.00	30.00	-2.50	-6.60	15.70	11.70	36.00	36.00	Pass
HE40	MCS0	1	9	2452	Full	16.00	16.10		30.00	30.00	-2.50	-6.60	13.50	9.50	36.00	36.00	Pass
HE40	MCS0	1	9	2452	242/62	13.60	13.50		30.00	30.00	-2.50	-6.60	11.10	6.90	36.00	36.00	Pass

2.4GHz Band MIMO																	
Mod.	Data Rate	NTx	CH.	Freq. (MHz)	RU Config	Average Conducted Power (dBm)			Conducted Power Limit (dBm)		DG (dBi)		EIRP Power (dBm)		EIRP Power Limit (dBm)		Pass /Fail
						Ant1	Ant2	SUM	Ant1	Ant2	Ant1	Ant2	Ant1	Ant2	Ant1	Ant2	
HE20	MCS0	2	1	2412	Full	17.10	16.20	19.68	30.00		-2.50		17.18		36.00		Pass
HE20	MCS0	2	1	2412	26/0	17.00	16.10	19.58	30.00		-2.50		17.08		36.00		Pass
HE20	MCS0	2	1	2412	52/37	17.00	15.90	19.50	30.00		-2.50		17.00		36.00		Pass
HE20	MCS0	2	1	2412	106/53	16.90	16.00	19.48	30.00		-2.50		16.98		36.00		Pass
HE20	MCS0	2	6	2437	Full	20.70	20.10	23.42	30.00		-2.50		20.92		36.00		Pass
HE20	MCS0	2	11	2462	Full	17.20	15.80	19.57	30.00		-2.50		17.07		36.00		Pass
HE20	MCS0	2	11	2462	26/8	17.00	15.70	19.41	30.00		-2.50		16.91		36.00		Pass
HE20	MCS0	2	11	2462	52/40	17.00	15.70	19.41	30.00		-2.50		16.91		36.00		Pass
HE20	MCS0	2	11	2462	106/54	17.00	15.70	19.41	30.00		-2.50		16.91		36.00		Pass
HE40	MCS0	2	3	2422	Full	17.30	16.60	19.97	30.00		-2.50		17.47		36.00		Pass
HE40	MCS0	2	3	2422	242/61	15.10	14.80	17.96	30.00		-2.50		15.46		36.00		Pass
HE40	MCS0	2	6	2437	Full	19.00	18.20	21.63	30.00		-2.50		19.13		36.00		Pass
HE40	MCS0	2	6	2437	242/61	18.90	18.10	21.53	30.00		-2.50		19.03		36.00		Pass
HE40	MCS0	2	9	2452	Full	16.60	15.40	19.05	30.00		-2.50		16.55		36.00		Pass
HE40	MCS0	2	9	2452	242/62	14.10	13.10	16.64	30.00		-2.50		14.14		36.00		Pass

Note: Measured power (dBm) has offset with cable loss.

<TXBF Mode>

Test Engineer:	Richard Qiu	Temperature:	21~25	°C
Test Date:	2020/2/21	Relative Humidity:	51~54	%

TEST RESULTS DATA
Peak Output Power

2.4GHz Band MIMO																	
Mod.	Data Rate	N _{Tx}	CH.	Freq. (MHz)	RU Config	Peak Conducted Power (dBm)			Conducted Power Limit (dBm)		DG (dBi)		EIRP Power (dBm)		EIRP Power Limit (dBm)		Pass /Fail
						Ant1	Ant2	SUM	Ant1	Ant2	Ant1	Ant2	Ant1	Ant2	Ant1	Ant2	
HE20	MCS0	2	1	2412	Full	24.67	23.33	27.06	30.00		-1.30		25.76		36.00		Pass
HE20	MCS0	2	6	2437	Full	23.81	22.58	26.25	30.00		-1.30		24.95		36.00		Pass
HE20	MCS0	2	11	2462	Full	24.56	23.33	27.00	30.00		-1.30		25.70		36.00		Pass

Note: Measured power (dBm) has offset with cable loss.

TEST RESULTS DATA
Average Output Power

2.4GHz Band MIMO																	
Mod.	Data Rate	N _{TX}	CH.	Freq. (MHz)	RU Config	Average Conducted Power (dBm)			Conducted Power Limit (dBm)		DG (dBi)		EIRP Power (dBm)		EIRP Power Limit (dBm)		Pass /Fail
						Ant1	Ant2	SUM	Ant1	Ant2	Ant1	Ant2	Ant1	Ant2	Ant1	Ant2	
HE20	MCS0	2	1	2412	Full	18.60	18.20	21.41	30.00		-1.30		20.11		36.00		Pass
HE20	MCS0	2	6	2437	Full	18.80	18.00	21.43	30.00		-1.30		20.13		36.00		Pass
HE20	MCS0	2	11	2462	Full	19.20	17.60	21.48	30.00		-1.30		20.18		36.00		Pass

Note: Measured power (dBm) has offset with cable loss.



Appendix B. Radiated Spurious Emission

Test Engineer :	Leo Lee, Mancy Chou and Bigshow Wang	Temperature :	24.2~24.8°C
		Relative Humidity :	55~61%

2.4GHz 2400~2483.5MHz

WIFI 802.11b (Band Edge @ 3m)

WIFI	Note	Frequency	Level	Over	Limit	Read	Antenna	Path	Preamp	Ant	Table	Peak	Pol.	
Ant.				Limit	Line	Level	Factor	Loss	Factor	Pos	Pos	Avg.		
1+2		(MHz)	(dBμV/m)	(dB)	(dBμV/m)	(dBμV)	(dB/m)	(dB)	(dB)	(cm)	(deg)	(P/A)	(H/V)	
802.11b CH 11 2462MHz	*	2462	106.75	-	-	94.05	27.58	16.23	31.11	397	305	P	H	
	*	2462	103.06	-	-	90.36	27.58	16.23	31.11	397	305	A	H	
		2490.44	54.67	-19.33	74	41.98	27.52	16.26	31.09	397	305	P	H	
		2483.52	43.44	-10.56	54	30.76	27.53	16.25	31.1	397	305	A	H	
													H	
														H
	*	2462	108.5	-	-	95.8	27.58	16.23	31.11	115	10	P	V	
	*	2462	104.89	-	-	92.19	27.58	16.23	31.11	115	10	A	V	
		2483.8	54.23	-19.77	74	41.55	27.53	16.25	31.1	115	10	P	V	
		2483.52	43.47	-10.53	54	30.79	27.53	16.25	31.1	115	10	A	V	
														V
													V	
Remark	1. No other spurious found. 2. All results are PASS against Peak and Average limit line.													



**2.4GHz 2400~2483.5MHz
WIFI 802.11b (Harmonic @ 3m)**

WIFI Ant. 1+2	Note	Frequency (MHz)	Level (dBμV/m)	Over Limit (dB)	Limit Line (dBμV/m)	Read Level (dBμV)	Antenna Factor (dB/m)	Path Loss (dB)	Preamp Factor (dB)	Ant Pos (cm)	Table Pos (deg)	Peak Avg. (P/A)	Pol. (H/V)	
802.11b CH 11 2462MHz		4924	36.95	-37.05	74	55.14	31.34	9.65	59.18	100	0	P	H	
		7386	41.23	-32.77	74	52.18	36.46	11.74	59.15	100	0	P	H	
													H	
													H	
			4924	36.49	-37.51	74	54.68	31.34	9.65	59.18	100	0	P	V
			7386	41.39	-32.61	74	52.34	36.46	11.74	59.15	100	0	P	V
														V
														V
Remark	1. No other spurious found. 2. All results are PASS against Peak and Average limit line.													



**2.4GHz 2400~2483.5MHz
WIFI 802.11n HT20 (Band Edge @ 3m)**

WIFI Ant. 1+2	Note	Frequency (MHz)	Level (dBμV/m)	Over Limit (dB)	Limit Line (dBμV/m)	Read Level (dBμV)	Antenna Factor (dB/m)	Path Loss (dB)	Preamp Factor (dB)	Ant Pos (cm)	Table Pos (deg)	Peak Avg. (P/A)	Pol. (H/V)
802.11n HT20 CH 11 2462MHz	*	2462	106.25	-	-	93.55	27.58	16.23	31.11	397	312	P	H
	*	2462	98.01	-	-	85.31	27.58	16.23	31.11	397	312	A	H
		2484.32	55.56	-18.44	74	42.88	27.53	16.25	31.1	397	312	P	H
		2483.52	44.65	-9.35	54	31.97	27.53	16.25	31.1	397	312	A	H
													H
													H
	*	2462	108.48	-	-	95.78	27.58	16.23	31.11	116	13	P	V
	*	2462	99.2	-	-	86.5	27.58	16.23	31.11	116	13	A	V
		2484.16	57.5	-16.5	74	44.82	27.53	16.25	31.1	116	13	P	V
		2483.52	47.28	-6.72	54	34.6	27.53	16.25	31.1	116	13	A	V
												V	
												V	
Remark	1. No other spurious found. 2. All results are PASS against Peak and Average limit line.												



2.4GHz 2400~2483.5MHz
WIFI 802.11n HT20 (Harmonic @ 3m)

Table with 14 columns: WIFI Ant. 1+2, Note, Frequency (MHz), Level (dBµV/m), Over Limit (dB), Limit Line (dBµV/m), Read Level (dBµV), Antenna Factor (dB/m), Path Loss (dB), Preamp Factor (dB), Ant Pos (cm), Table Pos (deg), Peak Avg. (P/A), Pol. (H/V). Rows include data for 802.11n HT20 CH 11 at 4924 and 7386 MHz, and a Remark section.



2.4GHz 2400~2483.5MHz

WIFI 802.11 ax HE20 Full (Band Edge @ 3m)

WIFI Ant.	Note	Frequency	Level	Over Limit	Limit Line	Read Level	Antenna Factor	Path Loss	Preamp Factor	Ant Pos	Table Pos	Peak Avg.	Pol.	
1+2		(MHz)	(dBμV/m)	(dB)	(dBμV/m)	(dBμV)	(dB/m)	(dB)	(dB)	(cm)	(deg)	(P/A)	(H/V)	
802.11ax HE20 Full CH 01 2412MHz		2389.17	57.16	-16.84	74	44.39	27.76	16.16	31.15	200	15	P	H	
		2390	48.25	-5.75	54	35.48	27.76	16.16	31.15	200	15	A	H	
	*	2412	107.95	-	-	95.22	27.68	16.18	31.13	200	15	P	H	
	*	2412	97.42	-	-	84.69	27.68	16.18	31.13	200	15	A	H	
													H	
													H	
			2329.635	54.86	-19.14	74	41.92	28.04	16.08	31.18	200	10	P	V
			2389.905	44.02	-9.98	54	31.25	27.76	16.16	31.15	200	10	A	V
	*		2412	100.04	-	-	87.31	27.68	16.18	31.13	200	10	P	V
	*		2412	89.64	-	-	76.91	27.68	16.18	31.13	200	10	A	V
												V		
												V		
Remark	1. No other spurious found. 2. All results are PASS against Peak and Average limit line.													



2.4GHz 2400~2483.5MHz

WIFI 802.11 ax HE20 Full (Harmonic @ 3m)

WIFI Ant. 1+2	Note	Frequency (MHz)	Level (dBμV/m)	Over Limit (dB)	Limit Line (dBμV/m)	Read Level (dBμV)	Antenna Factor (dB/m)	Path Loss (dB)	Preamp Factor (dB)	Ant Pos (cm)	Table Pos (deg)	Peak Avg. (P/A)	Pol. (H/V)
802.11ax HE20 Full CH 01 2412MHz		4824	35.21	-38.79	74	53.49	31.25	9.63	59.16	100	0	P	H
													H
													H
													H
802.11ax HE20 Full CH 01 2412MHz		4824	35.99	-38.01	74	54.27	31.25	9.63	59.16	100	0	P	V
													V
													V
802.11ax HE20 Full CH 01 2412MHz													V
													V
													V
Remark	1. No other spurious found. 2. All results are PASS against Peak and Average limit line.												



**2.4GHz 2400~2483.5MHz
WIFI 802.11 ax HE40 Full (Band Edge @ 3m)**

WIFI Ant. 1+2	Note	Frequency (MHz)	Level (dBμV/m)	Over Limit (dB)	Limit Line (dBμV/m)	Read Level (dBμV)	Antenna Factor (dB/m)	Path Loss (dB)	Preamp Factor (dB)	Ant Pos (cm)	Table Pos (deg)	Peak Avg. (P/A)	Pol. (H/V)
802.11ax HE40 Full CH 9 2452MHz		2329.04	54.34	-19.66	74	41.4	28.04	16.08	31.18	241	25	P	H
		2336.72	43.5	-10.5	54	30.55	28.03	16.09	31.17	241	25	A	H
	*	2452	104.19	-	-	91.48	27.6	16.22	31.11	241	25	P	H
	*	2452	95.59	-	-	82.88	27.6	16.22	31.11	241	25	A	H
		2486.77	61.41	-12.59	74	48.72	27.53	16.26	31.1	241	25	P	H
		2483.53	48.58	-5.42	54	35.9	27.53	16.25	31.1	241	25	A	H
		2379.12	54.32	-19.68	74	41.5	27.83	16.14	31.15	200	40	P	V
		2312.72	43.58	-10.42	54	30.63	28.07	16.06	31.18	200	40	A	V
	*	2452	99.65	-	-	86.94	27.6	16.22	31.11	200	40	P	V
	*	2452	88.99	-	-	76.28	27.6	16.22	31.11	200	40	A	V
		2485.96	56.57	-17.43	74	43.88	27.53	16.26	31.1	200	40	P	V
		2483.53	44.85	-9.15	54	32.17	27.53	16.25	31.1	200	40	A	V
Remark	1. No other spurious found. 2. All results are PASS against Peak and Average limit line.												



2.4GHz 2400~2483.5MHz

WIFI 802.11 ax HE40 Full (Harmonic @ 3m)

WIFI Ant. 1+2	Note	Frequency (MHz)	Level (dBμV/m)	Over Limit (dB)	Limit Line (dBμV/m)	Read Level (dBμV)	Antenna Factor (dB/m)	Path Loss (dB)	Preamp Factor (dB)	Ant Pos (cm)	Table Pos (deg)	Peak Avg. (P/A)	Pol. (H/V)	
802.11ax HE40 Full CH 9 2452MHz		4904	35.61	-38.39	74	53.93	31.22	9.64	59.18	100	0	P	H	
		7356	40.87	-33.13	74	51.73	36.58	11.72	59.16	100	0	P	H	
													H	
													H	
			4904	35.52	-38.48	74	53.84	31.22	9.64	59.18	100	0	P	V
			7356	41.98	-32.02	74	52.84	36.58	11.72	59.16	100	0	P	V
														V
													V	
Remark	1. No other spurious found. 2. All results are PASS against Peak and Average limit line.													



Emission below 1GHz
2.4GHz WIFI 802. 11ax HE40 (LF)

WIFI Ant.	Note	Frequency	Level	Over Limit	Limit Line	Read Level	Antenna Factor	Path Loss	Preamp Factor	Ant Pos	Table Pos	Peak Avg.	Pol.	
1+2		(MHz)	(dBμV/m)	(dB)	(dBμV/m)	(dBμV)	(dB/m)	(dB)	(dB)	(cm)	(deg)	(P/A)	(H/V)	
2.4GHz 802. 11AX(HE40) LF		67.83	24.1	-15.9	40	42.68	12.54	1.04	32.25	-	-	P	H	
		165.8	23.74	-19.76	43.5	38.15	16.18	1.62	32.41	-	-	P	H	
		271.53	31.71	-14.29	46	43.24	18.73	2.05	32.46	-	-	P	H	
		298.69	39.35	-6.65	46	50.51	19.08	2.15	32.52	100	116	Q	H	
		352.04	39.25	-6.75	46	49.04	20.21	2.33	32.43	-	-	P	H	
		379.2	39.47	-6.53	46	48.24	20.97	2.44	32.26	-	-	P	H	
														H
														H
														H
														H
														H
														H
			40.67	32.84	-7.16	40	45.24	19.11	0.82	32.34	-	-	P	V
			298.69	35.11	-10.89	46	46.27	19.08	2.15	32.52	-	-	P	V
			325.85	34.22	-11.78	46	44.8	19.55	2.24	32.48	-	-	P	V
			451.95	32.9	-13.1	46	39.85	22.91	2.62	32.58	-	-	P	V
			716.76	39.8	-6.2	46	42.03	26.73	3.33	32.42	100	0	P	V
			914.64	35.67	-10.33	46	34.53	28.87	3.78	31.73	-	-	P	V
													V	
													V	
													V	
													V	
													V	
													V	
Remark	1. No other spurious found. 2. All results are PASS against limit line.													



Note symbol

*	Fundamental Frequency which can be ignored. However, the level of any unwanted emissions shall not exceed the level of the fundamental frequency.
!	Test result is over limit line.
P/A	Peak or Average
H/V	Horizontal or Vertical



A calculation example for radiated spurious emission is shown as below:

WIFI	Note	Frequency	Level	Over	Limit	Read	Antenna	Path	Preamp	Ant	Table	Peak	Pol.
Ant.				Limit	Line	Level	Factor	Loss	Factor	Pos	Pos	Avg.	
1+2		(MHz)	(dBμV/m)	(dB)	(dBμV/m)	(dBμV)	(dB/m)	(dB)	(dB)	(cm)	(deg)	(P/A)	(H/V)
802.11b		2390	55.45	-18.55	74	54.51	32.22	4.58	35.86	103	308	P	H
CH 01													
2412MHz		2390	43.54	-10.46	54	42.6	32.22	4.58	35.86	103	308	A	H

1. Path Loss(dB) = Cable loss(dB) + Filter loss(dB) + Attenuator loss(dB)
2. Level(dBμV/m) =
Antenna Factor(dB/m) + Path Loss(dB) + Read Level(dBμV) - Preamp Factor(dB)
3. Over Limit(dB) = Level(dBμV/m) – Limit Line(dBμV/m)

For Peak Limit @ 2390MHz:

1. Level(dBμV/m)
= Antenna Factor(dB/m) + Path Loss(dB) + Read Level(dBμV) - Preamp Factor(dB)
= 32.22(dB/m) + 4.58(dB) + 54.51(dBμV) – 35.86 (dB)
= 55.45 (dBμV/m)
2. Over Limit(dB)
= Level(dBμV/m) – Limit Line(dBμV/m)
= 55.45(dBμV/m) – 74(dBμV/m)
= -18.55(dB)

For Average Limit @ 2390MHz:

1. Level(dBμV/m)
= Antenna Factor(dB/m) + Path Loss(dB) + Read Level(dBμV) - Preamp Factor(dB)
= 32.22(dB/m) + 4.58(dB) + 42.6(dBμV) – 35.86 (dB)
= 43.54 (dBμV/m)
2. Over Limit(dB)
= Level(dBμV/m) – Limit Line(dBμV/m)
= 43.54(dBμV/m) – 54(dBμV/m)
= -10.46(dB)

Both peak and average measured complies with the limit line, so test result is “PASS”.



Appendix D. Radiated Spurious Emission Plots

Test Engineer :	Leo Lee, Mancy Chou and Bigshow Wang	Temperature :	24.2~24.8°C
		Relative Humidity :	55~61%

Note symbol

-L	Low channel location
-R	High channel location



2.4GHz 2400~2483.5MHz
WIFI 802.11b (Band Edge @ 3m)

WIFI	2.4GHz 2400~2483.5MHz Band Edge @ 3m	
ANT	802.11b CH11 2462MHz	
1+2	Horizontal	Fundamental
Peak	<p>Site : 03CH15-HY Condition : PEAK_BE_74 3m 91200_15_1620 HORIZONTAL RBW:1000.000KHz VBW:3000.000KHz SWT:Auto Detector : Peak Project : 9D0635</p>	<p>Site : 03CH15-HY Condition : PEAK_74 3m 91200_15_1620 HORIZONTAL RBW:1000.000KHz VBW:3000.000KHz SWT:Auto Detector : Peak Project : 9D0635</p>
Avg.	<p>Site : 03CH15-HY Condition : AVG_BE_54 3m 91200_15_1620 HORIZONTAL RBW:1000.000KHz VBW:0.010KHz SWT:Auto Detector : Peak Project : 9D0635</p>	<p>Site : 03CH15-HY Condition : AVG_54 3m 91200_15_1620 HORIZONTAL RBW:1000.000KHz VBW:0.010KHz SWT:Auto Detector : Peak Project : 9D0635</p>

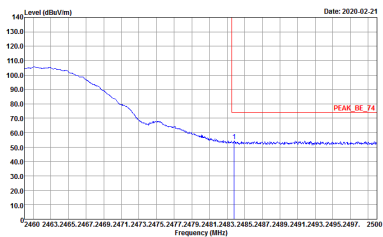
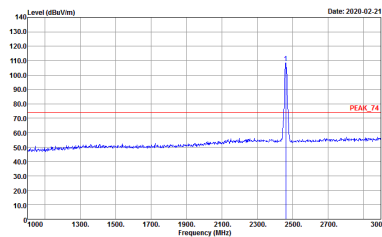
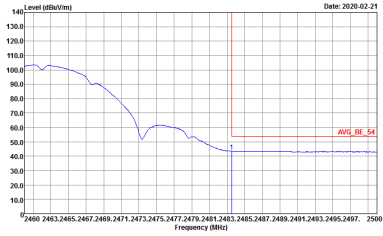
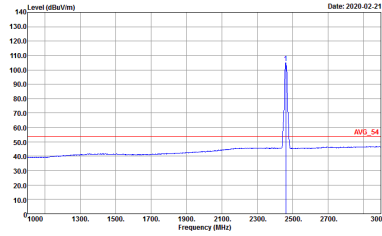

WIFI	2.4GHz 2400~2483.5MHz Band Edge @ 3m	
ANT	802.11b CH11 2462MHz	
1+2	Vertical	Fundamental
Peak	 <p>Date: 2020-02-21</p> <p>Site : 03CH15-HY Condition : PEAK_BE_74 3m 91200_15_1620 VERTICAL RBW:1000.000KHz VBW:3000.000KHz SWT:Auto Detector : Peak Project : 9D0635</p>	 <p>Date: 2020-02-21</p> <p>Site : 03CH15-HY Condition : PEAK_74 3m 91200_15_1620 VERTICAL RBW:1000.000KHz VBW:3000.000KHz SWT:Auto Detector : Peak Project : 9D0635</p>
Avg.	 <p>Date: 2020-02-21</p> <p>Site : 03CH15-HY Condition : AVG_BE_54 3m 91200_15_1620 VERTICAL RBW:1000.000KHz VBW:0.010KHz SWT:Auto Detector : Peak Project : 9D0635</p>	 <p>Date: 2020-02-21</p> <p>Site : 03CH15-HY Condition : AVG_54 3m 91200_15_1620 VERTICAL RBW:1000.000KHz VBW:0.010KHz SWT:Auto Detector : Peak Project : 9D0635</p>

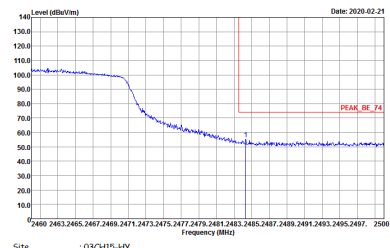
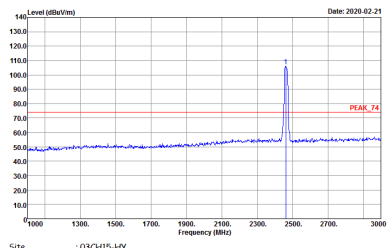
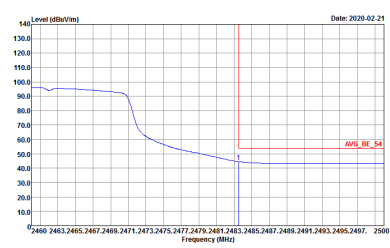
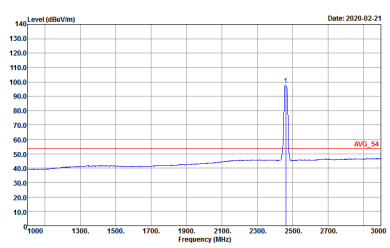

2.4GHz 2400~2483.5MHz
WIFI 802.11n HT20 (Band Edge @ 3m)

WIFI	2.4GHz 2400~2483.5MHz Band Edge @ 3m	
ANT	802.11n HT20 CH11 2462MHz	
1+2	Horizontal	Fundamental
Peak	 <p>Site : 03CH15-HY Condition : PEAK_BE_74 3m 91200_15_1620 HORIZONTAL : RBW:1000.000kHz VBW:3000.000kHz SWT:Auto Detector : Peak Project : 9D0635</p>	 <p>Site : 03CH15-HY Condition : PEAK_74 3m 91200_15_1620 HORIZONTAL : RBW:1000.000kHz VBW:3000.000kHz SWT:Auto Detector : Peak Project : 9D0635</p>
Avg.	 <p>Site : 03CH15-HY Condition : AVG_BE_54 3m 91200_15_1620 HORIZONTAL : RBW:1000.000kHz VBW:0.010kHz SWT:Auto Detector : Peak Project : 9D0635</p>	 <p>Site : 03CH15-HY Condition : AVG_54 3m 91200_15_1620 HORIZONTAL : RBW:1000.000kHz VBW:0.010kHz SWT:Auto Detector : Peak Project : 9D0635</p>

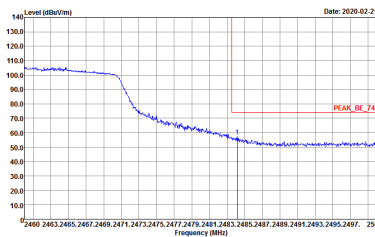
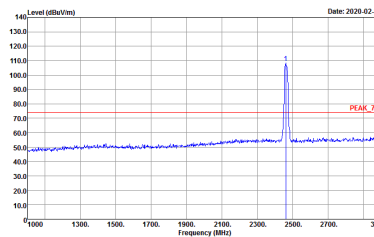
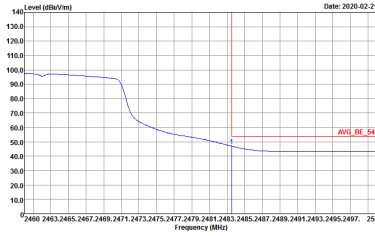
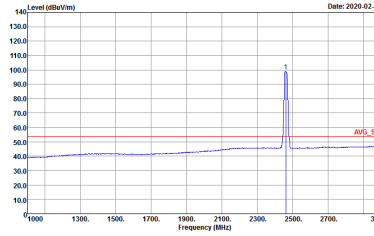

WIFI	2.4GHz 2400~2483.5MHz Fundamental @ 3m	
ANT	802.11n HT20 CH11 2462MHz	
1+2	Vertical	Fundamental
<p>Peak</p>	 <p>Site : 03CH15-HY Condition : PEAK_BE_74 3m 9120D_15_1620 VERTICAL Detector : Peak Project : 9D0635</p>	 <p>Site : 03CH15-HY Condition : PEAK_74 3m 9120D_15_1620 VERTICAL Detector : Peak Project : 9D0635</p>
<p>Avg.</p>	 <p>Site : 03CH15-HY Condition : AVG_BE_54 3m 9120D_15_1620 VERTICAL Detector : Peak Project : 9D0635</p>	 <p>Site : 03CH15-HY Condition : AVG_54 3m 9120D_15_1620 VERTICAL Detector : Peak Project : 9D0635</p>



2.4GHz 2400~2483.5MHz

WIFI 802.11b (Harmonic @ 3m)

WIFI	2.4GHz 2400~2483.5MHz Harmonic @ 3m	
ANT	802.11b CH11 2462MHz	
1+2	Horizontal	Vertical
Peak Avg.	<p>Site : 03CH15-HY Condition : PEAK_74 3m 91200_15_1620 HORIZONTAL Detector : Peak Project : 9D0635-01</p>	<p>Site : 03CH15-HY Condition : PEAK_74 3m 91200_15_1620 VERTICAL Detector : Peak Project : 9D0635-01</p>



2.4GHz 2400~2483.5MHz
WIFI 802.11n HT20 (Harmonic @ 3m)

Table with 2 columns: Horizontal and Vertical. Each column contains a graph of Level (dBuV/m) vs Frequency (MHz) and associated test parameters like Site, Condition, Detector, and Project.



2.4GHz 2400~2483.5MHz

WIFI 802.11 ax HE20 Full (Band Edge @ 3m)

WIFI	2.4GHz 2400~2483.5MHz Band Edge @ 3m	
ANT	802.11 ax HE20 Full CH01 2412MHz	
1+2	Horizontal	Fundamental
Peak	<p>Site : 03CH15-HY Condition : PEAK_BE_74 3m 91200_15_1620 HORIZONTAL Detector : Peak Project : 9D0635-01</p>	<p>Site : 03CH15-HY Condition : PEAK_74 3m 91200_15_1620 HORIZONTAL Detector : Peak Project : 9D0635-01</p>
Avg.	<p>Site : 03CH15-HY Condition : AVG_BE_54 3m 91200_15_1620 HORIZONTAL Detector : Peak Project : 9D0635-01</p>	<p>Site : 03CH15-HY Condition : AVG_54 3m 91200_15_1620 HORIZONTAL Detector : Peak Project : 9D0635-01</p>

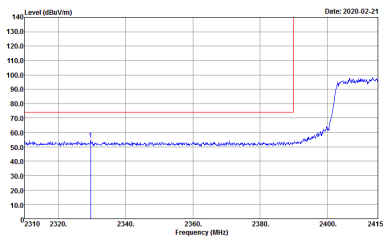
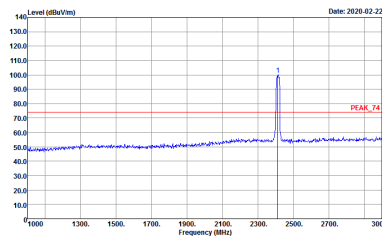
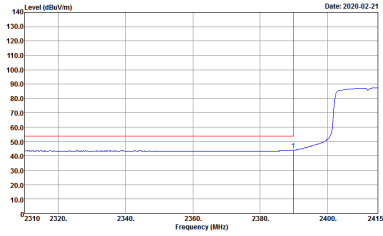
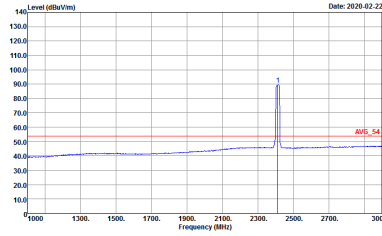

WIFI	2.4GHz 2400~2483.5MHz Band Edge @ 3m	
ANT	802.11 ax HE20 Full CH01 2412MHz	
1+2	Vertical	Fundamental
Peak	 <p>Site : 03CH15-HY Condition : PEAK_BE_74 3m 91200_15_1620 VERTICAL Detector : Peak Project : 9D0635-01</p>	 <p>Site : 03CH15-HY Condition : PEAK_74 3m 91200_15_1620 VERTICAL Detector : Peak Project : 9D0635-01</p>
Avg.	 <p>Site : 03CH15-HY Condition : AVG_BE_54 3m 91200_15_1620 VERTICAL Detector : Peak Project : 9D0635-01</p>	 <p>Site : 03CH15-HY Condition : AVG_54 3m 91200_15_1620 VERTICAL Detector : Peak Project : 9D0635-01</p>



2.4GHz 2400~2483.5MHz

WIFI 802.11 ax HE40 Full (Band Edge @ 3m)

WIFI	2.4GHz 2400~2483.5MHz Band Edge @ 3m	
ANT	802.11 ax HE40 Full CH09 2452MHz - L	
1+2	Horizontal	Fundamental
Peak	<p>Site : 03CH15-HY Condition : PEAK_BE_74 3m 91200_15_1620 HORIZONTAL Detector : Peak Project : 9D0635-01</p>	<p>Site : 03CH15-HY Condition : PEAK_74 3m 91200_15_1620 HORIZONTAL Detector : Peak Project : 9D0635-01</p>
Avg.	<p>Site : 03CH15-HY Condition : AVG_BE_54 3m 91200_15_1620 HORIZONTAL Detector : Peak Project : 9D0635-01</p>	<p>Site : 03CH15-HY Condition : AVG_54 3m 91200_15_1620 HORIZONTAL Detector : Peak Project : 9D0635-01</p>

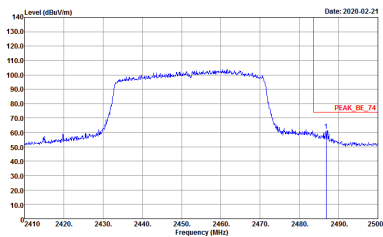
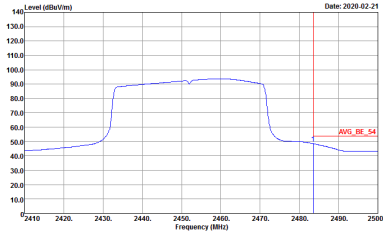

WIFI	2.4GHz 2400~2483.5MHz Band Edge @ 3m	
ANT	802.11 ax HE40 Full CH09 2452MHz - R	
1+2	Horizontal	Fundamental
<p>Peak</p>	 <p>Site : 03CH15-HY Condition : PEAK_BE_74 3m 91200_15_1620 HORIZONTAL Detector : Peak Project : 9D0635-01</p>	<p>Left blank</p>
<p>Avg.</p>	 <p>Site : 03CH15-HY Condition : AVG_BE_54 3m 91200_15_1620 HORIZONTAL Detector : Peak Project : 9D0635-01</p>	<p>Left blank</p>

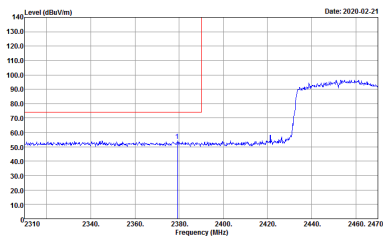
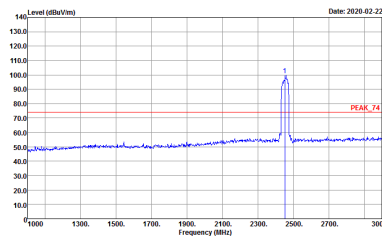
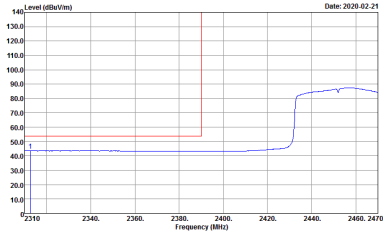
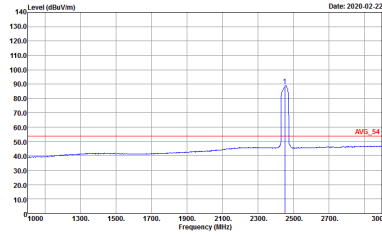

WIFI	2.4GHz 2400~2483.5MHz Band Edge @ 3m	
ANT	802.11 ax HE40 Full CH09 2452MHz - L	
1+2	Vertical	Fundamental
Peak	 <p>Level (dBm/100MHz) vs Frequency (MHz) plot for Peak Vertical. The plot shows a signal level that rises from approximately 50 dBm/100MHz at 2380 MHz to about 90 dBm/100MHz at 2450 MHz. A red vertical line is drawn at 2380 MHz.</p> <p>Site : 03CH15-HY Condition : PEAK_BE_74 3m 91200_15_1620 VERTICAL : RBW:1000.000KHz VBW:3000.000KHz SWT:Auto Detector : Peak Project : 9D0635-01</p>	 <p>Level (dBm/100MHz) vs Frequency (MHz) plot for Peak Fundamental. The plot shows a sharp peak at approximately 2452 MHz with a level of about 100 dBm/100MHz. A red horizontal line is drawn at 74 dBm/100MHz, labeled 'PEAK_74'.</p> <p>Site : 03CH15-HY Condition : PEAK_74 3m 91200_15_1620 VERTICAL : RBW:1000.000KHz VBW:3000.000KHz SWT:Auto Detector : Peak Project : 9D0635-01</p>
Avg.	 <p>Level (dBm/100MHz) vs Frequency (MHz) plot for Avg Vertical. The plot shows a signal level that rises from approximately 50 dBm/100MHz at 2380 MHz to about 90 dBm/100MHz at 2450 MHz. A red vertical line is drawn at 2380 MHz.</p> <p>Site : 03CH15-HY Condition : AVG_BE_54 3m 91200_15_1620 VERTICAL : RBW:1000.000KHz VBW:0.010KHz SWT:Auto Detector : Peak Project : 9D0635-01</p>	 <p>Level (dBm/100MHz) vs Frequency (MHz) plot for Avg Fundamental. The plot shows a sharp peak at approximately 2452 MHz with a level of about 90 dBm/100MHz. A red horizontal line is drawn at 54 dBm/100MHz, labeled 'AVG_54'.</p> <p>Site : 03CH15-HY Condition : AVG_54 3m 91200_15_1620 VERTICAL : RBW:1000.000KHz VBW:0.010KHz SWT:Auto Detector : Peak Project : 9D0635-01</p>

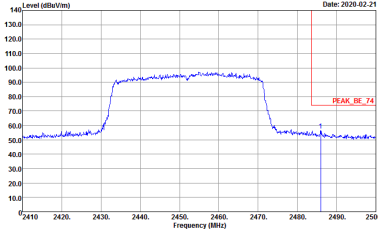
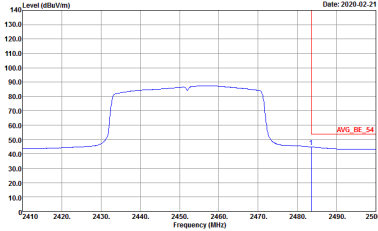

WIFI	2.4GHz 2400~2483.5MHz Band Edge @ 3m	
ANT	802.11 ax HE40 Full CH09 2452MHz - R	
1+2	Vertical	Fundamental
<p>Peak</p>	 <p>Site : 03CH15-HY Condition : PEAK_BE_74 3m 91200_15_1620 VERTICAL Detector : Peak Project : 9D0635-01</p>	<p>Left blank</p>
<p>Avg.</p>	 <p>Site : 03CH15-HY Condition : AVG_BE_54 3m 91200_15_1620 VERTICAL Detector : Peak Project : 9D0635-01</p>	<p>Left blank</p>



2.4GHz 2400~2483.5MHz
WIFI 802.11 ax HE20 Full (Harmonic @ 3m)

WIFI	2.4GHz 2400~2483.5MHz Harmonic @ 3m	
ANT	802.11 ax HE20 Full CH01 2412MHz	
1+2	Horizontal	Vertical
Peak Avg.	<p>Site : 03CH15-HY Condition : PEAK_74 3m 9120D_15_1620 HORIZONTAL Detector : Peak Project : 9D0635-01</p>	<p>Site : 03CH15-HY Condition : PEAK_74 3m 9120D_15_1620 VERTICAL Detector : Peak Project : 9D0635-01</p>



2.4GHz 2400~2483.5MHz

WIFI 802.11 ax HE40 Full (Harmonic @ 3m)

WIFI	2.4GHz 2400~2483.5MHz Harmonic @ 3m	
ANT	802.11 ax HE40 Full CH09 2452MHz	
1+2	Horizontal	Vertical
Peak Avg.		



Emission below 1GHz
2.4GHz WIFI 802. 11AX(HE40) (LF)

WIFI	2.4GHz 2400~2483.5MHz	
ANT	802. 11AX(HE40) LF	
1+2	Horizontal	Vertical
QP / Peak	<p>Site : 03CH15-HY Condition : QP 3m 80LOG_15_41912 HORIZONTAL Detector : Peak Project : 9D0635-01</p>	<p>Site : 03CH15-HY Condition : QP 3m 80LOG_15_41912 VERTICAL Detector : Peak Project : 9D0635-01</p>



Appendix E. Duty Cycle Plots

Antenna	Band	Duty Cycle(%)	T(us)	1/T(kHz)	VBW Setting	Duty Factor(dB)
1+2	802.11b for Ant 1	100.00	-	-	10Hz	0.00
1+2	802.11b for Ant 2	100.00	-	-	10Hz	0.00
1+2	2.4GHz 802.11n HT20 for Ant 1	100.00	-	-	10Hz	0.00
1+2	2.4GHz 802.11n HT20 for Ant 2	100.00	-	-	10Hz	0.00
1+2	2.4GHz 802.11ax HE 20 for Ant 1	100.00	-	-	10Hz	0.00
1+2	2.4GHz 802.11ax HE 20 for Ant 2	100.00	-	-	10Hz	0.00
1+2	2.4GHz 802.11ax HE 40 for Ant 1	100.00	-	-	10Hz	0.00
1+2	2.4GHz 802.11ax HE 40 for Ant 2	100.00	-	-	10Hz	0.00



MIMO <Ant. 1>

802.11b

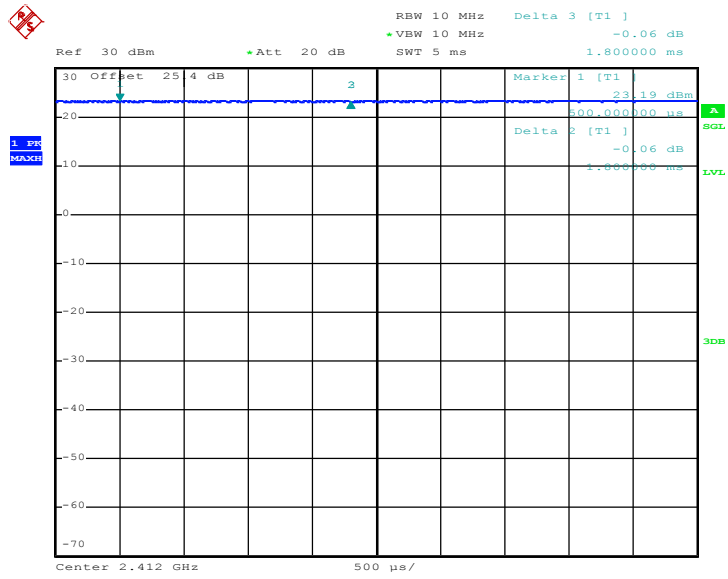

Date: 13.FEB.2020 03:13:38

802.11n HT20

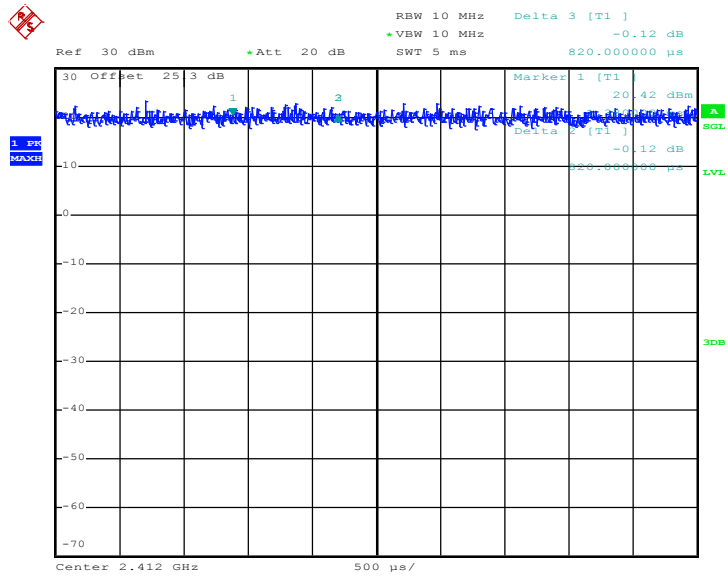

Date: 13.FEB.2020 05:18:25



802.11ax HE20

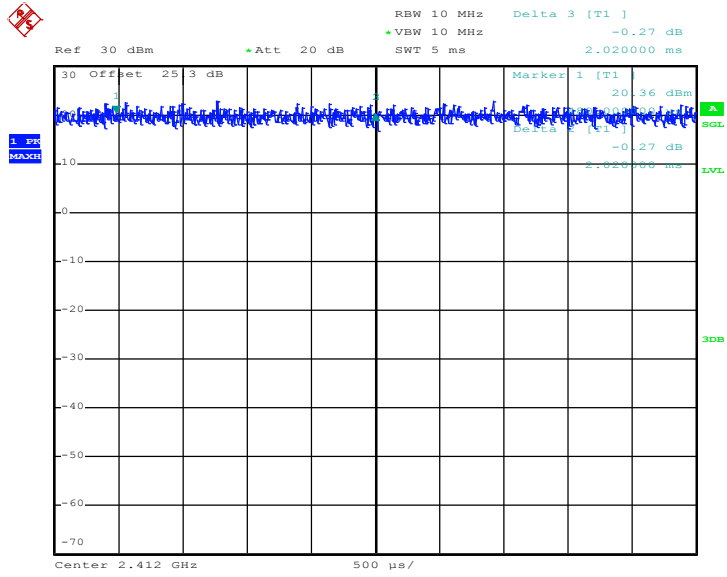

Date: 13.FEB.2020 06:03:21

802.11ax HE40

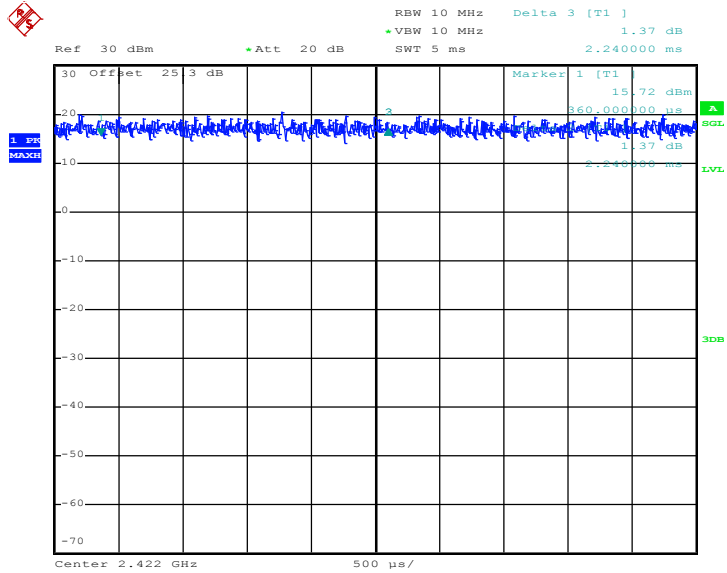

Date: 13.FEB.2020 06:15:26



MIMO <Ant. 2>

802.11b

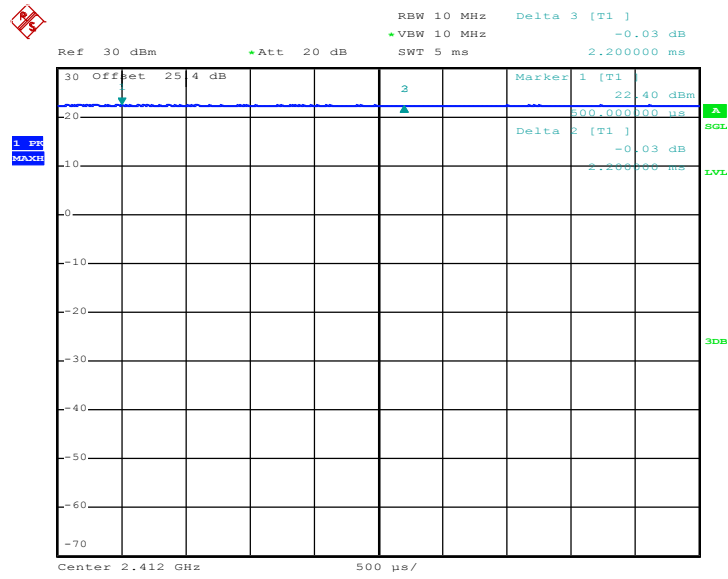

Date: 13.FEB.2020 03:14:20

802.11n HT20

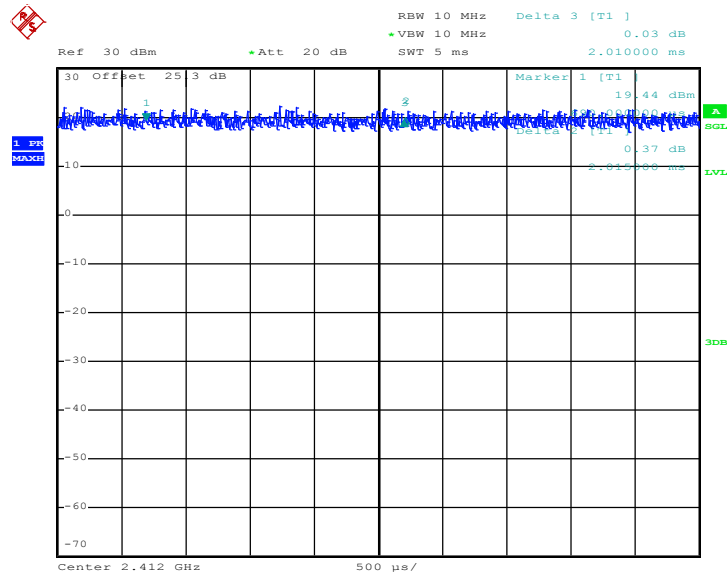

Date: 13.FEB.2020 05:17:53



802.11ax HE20

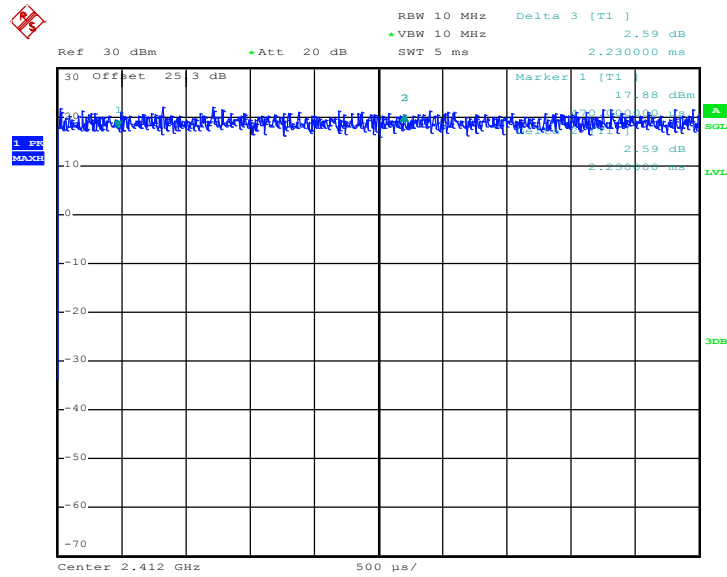

Date: 13.FEB.2020 06:04:03

802.11ax HE40

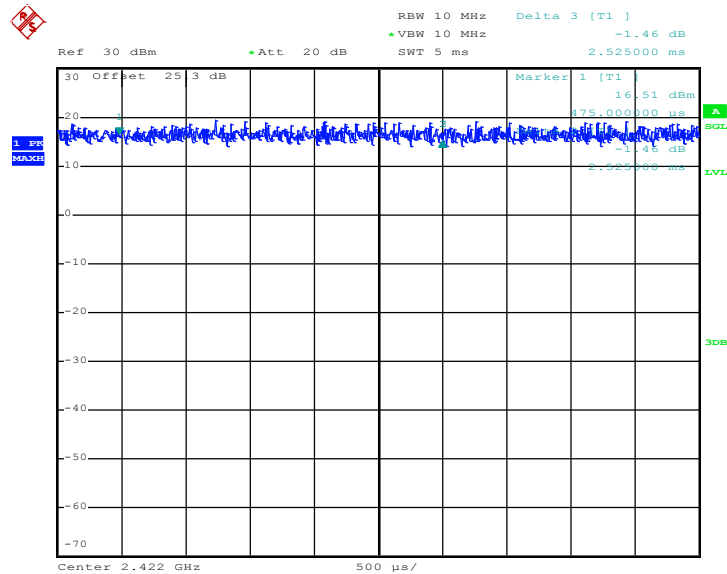

Date: 13.FEB.2020 06:16:07

—THE END—