



FCC RADIO TEST REPORT

FCC ID : IHDT56YJ1
Equipment : Mobile Cellular Phone
Brand Name : Motorola
Model Name : XT2061-1
Applicant : Motorola Mobility, LLC
222 W Merchandise Mart Plaza, Suite
1800, Chicago, IL 60654, United States
Manufacturer : Motorola Mobility, LLC
222 W Merchandise Mart Plaza, Suite
1800, Chicago, IL 60654, United States
Standard : FCC Part 15 Subpart E §15.407

The product was received on Dec. 06, 2019 and testing was started from Dec.26, 2019 and completed on Feb. 12, 2020. We, SPORTON INTERNATIONAL INC., EMC & Wireless Communications Laboratory, would like to declare that the tested sample has been evaluated in accordance with the test procedures and has been in compliance with the applicable technical standards.

The report must not be used by the client to claim product certification, approval, or endorsement by TAF or any agency of government.

The test results in this report apply exclusively to the tested model / sample. Without written approval of SPORTON INTERNATIONAL INC. EMC & Wireless Communications Laboratory, the test report shall not be reproduced except in full.

Louis Wu

Approved by: Louis Wu

SPORTON INTERNATIONAL INC. EMC & Wireless Communications Laboratory
No. 52, Huaya 1st Rd., Guishan Dist., Taoyuan City, Taiwan (R.O.C.)



Table of Contents

History of this test report 3

Summary of Test Result..... 4

1 General Description 5

 1.1 Product Feature of Equipment Under Test 5

 1.2 Product Specification of Equipment Under Test 6

 1.3 Modification of EUT..... 10

 1.4 Testing Location..... 11

 1.5 Applicable Standards 11

2 Test Configuration of Equipment Under Test..... 12

 2.1 Carrier Frequency and Channel..... 12

 2.2 Test Mode 13

 2.3 Connection Diagram of Test System 16

 2.4 Support Unit used in test configuration and system 18

 2.5 EUT Operation Test Setup..... 18

 2.6 Measurement Results Explanation Example 18

3 Test Result 19

 3.1 26dB & 99% Occupied Bandwidth Measurement 19

 3.2 Maximum Conducted Output Power Measurement 22

 3.3 Power Spectral Density Measurement 24

 3.4 Unwanted Emissions Measurement 28

 3.5 AC Conducted Emission Measurement 34

 3.6 Automatically Discontinue Transmission 36

 3.7 Antenna Requirements 38

4 List of Measuring Equipment 40

5 Uncertainty of Evaluation 43

Appendix A. Conducted Test Results

Appendix B. AC Conducted Emission Test Result

Appendix C. Radiated Spurious Emission

Appendix D. Radiated Spurious Emission Plots

Appendix E. Duty Cycle Plots



Summary of Test Result

Report Clause	Ref Std. Clause	Test Items	Result (PASS/FAIL)	Remark
3.1	15.403(i)	26dB Bandwidth	Pass	-
3.1	2.1049	99% Occupied Bandwidth	Reporting only	-
3.2	15.407(a)	Maximum Conducted Output Power	Pass	-
3.3	15.407(a)	Power Spectral Density	Pass	-
3.4	15.407(b)	Unwanted Emissions	Pass	Under limit 3.22 dB at 5726.920 MHz
3.5	15.207	AC Conducted Emission	Pass	Under limit 18.11 dB at 2.300 MHz
3.6	15.407(c)	Automatically Discontinue Transmission	Pass	-
3.7	15.203 15.407(a)	Antenna Requirement	Pass	-

Declaration of Conformity:
The test results with all measurement uncertainty excluded are presented in accordance with the regulation limits or requirements declared by manufacturers.
Comments and Explanations:
The declared of product specification for EUT presented in the report are provided by the manufacturer, and the manufacturer takes all the responsibilities for the accuracy of product specification.

Reviewed by: Wii Chang
Report Producer: Ann Lee



1 General Description

1.1 Product Feature of Equipment Under Test

Product Feature	
Equipment	Mobile Cellular Phone
Brand Name	Motorola
Model Name	XT2061-1
FCC ID	IHDT56YJ1
IMEI Code	Conducted : IMEI: 359120100011371 Conduction : IMEI: 359120100016479 Radiation : IMEI: 359120100017048
EUT supports Radios application	CDMA/EV-DO/GSM/EGPRS/WCDMA/HSPA/LTE/5G NR/ GNSS/NFC/WPC WLAN 11b/g/n HT20 WLAN 11a/n HT20/HT40 WLAN 11ac VHT20/VHT40/VHT80 WLAN 11ax HE20/HE40/HE80 Bluetooth BR/EDR/LE
HW Version	DVT2
EUT Stage	Identical Prototype

Remark: The above EUT's information was declared by manufacturer.

Accessory List	
AC Adapter 1	Brand Name : Motorola
	Model Name : SC-51 (SA18C30116)
	Manufacturer : Chenyang
AC Adapter 2	Brand Name : Motorola
	Model Name : SC-51 (SA18C62985)
	Manufacturer : Acbel
Battery	Brand Name : ATL
	Model Name : LW50
USB Cable 1	Brand Name : Motorola
	Model Name : SC18C24367
	Manufacturer : Saibao
USB Cable 2	Brand Name : Motorola
	Model Name : SC18C24368
	Manufacturer : Luxshare



1.2 Product Specification of Equipment Under Test

Standards-related Product Specification	
Tx/Rx Frequency Range	5180 MHz ~ 5240 MHz 5260 MHz ~ 5320 MHz 5500 MHz ~ 5720 MHz
Maximum Output Power to Antenna <CDD Modes>	<p><5180 MHz ~ 5240 MHz></p> <p><Ant. 1> 802.11a : 17.20 dBm / 0.0525 W 802.11n HT20 : 16.80 dBm / 0.0479 W 802.11n HT40 : 16.90 dBm / 0.0490 W 802.11ac VHT20: 17.10 dBm / 0.0513 W 802.11ac VHT40: 17.00 dBm / 0.0501 W 802.11ac VHT80: 14.60 dBm / 0.0288 W 802.11ax HE20 : 17.00 dBm / 0.0501 W 802.11ax HE40 : 17.20 dBm / 0.0525 W 802.11ax HE80 : 14.70 dBm / 0.0295 W</p> <p><Ant. 2> 802.11a : 17.10 dBm / 0.0513 W 802.11n HT20 : 17.00 dBm / 0.0501 W 802.11n HT40 : 16.80 dBm / 0.0479 W 802.11ac VHT20: 17.10 dBm / 0.0513 W 802.11ac VHT40: 16.90 dBm / 0.0490 W 802.11ac VHT80: 14.90 dBm / 0.0309 W 802.11ax HE20 : 16.80 dBm / 0.0479 W 802.11ax HE40 : 17.20 dBm / 0.0525 W 802.11ax HE80 : 14.80 dBm / 0.0302 W</p> <p>MIMO <Ant. 1 + 2> 802.11a : 20.23 dBm / 0.1054 W 802.11n HT20 : 20.18 dBm / 0.1042 W 802.11n HT40 : 19.74 dBm / 0.0942 W 802.11ac VHT20: 20.24 dBm / 0.1057 W 802.11ac VHT40: 19.80 dBm / 0.0955 W 802.11ac VHT80: 17.94 dBm / 0.0622 W 802.11ax HE20 : 20.00 dBm / 0.1000 W 802.11ax HE40 : 19.95 dBm / 0.0989 W 802.11ax HE80 : 17.84 dBm / 0.0608 W</p>



Standards-related Product Specification	
Maximum Output Power to Antenna <CDD Modes>	<5260 MHz ~ 5320 MHz>
	<Ant. 1>
	802.11a : 17.20 dBm / 0.0525 W
	802.11n HT20 : 16.90 dBm / 0.0490 W
	802.11n HT40 : 16.90 dBm / 0.0490 W
	802.11ac VHT20: 17.00 dBm / 0.0501 W
	802.11ac VHT40: 17.00 dBm / 0.0501 W
	802.11ac VHT80: 15.00 dBm / 0.0316 W
	802.11ax HE20 : 17.00 dBm / 0.0501 W
	802.11ax HE40 : 17.00 dBm / 0.0501 W
	802.11ax HE80 : 14.60 dBm / 0.0288 W
	<Ant. 2>
	802.11a : 17.20 dBm / 0.0525 W
	802.11n HT20 : 17.00 dBm / 0.0501 W
	802.11n HT40 : 17.00 dBm / 0.0501 W
	802.11ac VHT20: 17.10 dBm / 0.0513 W
	802.11ac VHT40: 17.10 dBm / 0.0513 W
	802.11ac VHT80: 15.30 dBm / 0.0339 W
	802.11ax HE20 : 16.90 dBm / 0.0490 W
	802.11ax HE40 : 17.00 dBm / 0.0501 W
802.11ax HE80 : 14.60 dBm / 0.0288 W	
MIMO <Ant. 1 + 2>	
802.11a : 20.27 dBm / 0.1064 W	
802.11n HT20 : 20.11 dBm / 0.1026 W	
802.11n HT40 : 20.12 dBm / 0.1028 W	
802.11ac VHT20: 20.17 dBm / 0.1040 W	
802.11ac VHT40: 20.18 dBm / 0.1042 W	
802.11ac VHT80: 18.38 dBm / 0.0689 W	
802.11ax HE20 : 19.94 dBm / 0.0986 W	
802.11ax HE40 : 19.91 dBm / 0.0979 W	
802.11ax HE80 : 17.66 dBm / 0.0583 W	



Standards-related Product Specification	
<p>Maximum Output Power to Antenna <CDD Modes></p>	<p><5500 MHz ~ 5700 MHz> <Ant. 1> 802.11a : 17.10 dBm / 0.0513 W 802.11n HT20 : 17.10 dBm / 0.0513 W 802.11n HT40 : 17.00 dBm / 0.0501 W 802.11ac VHT20: 17.30 dBm / 0.0537 W 802.11ac VHT40: 17.00 dBm / 0.0501 W 802.11ac VHT80: 17.00 dBm / 0.0501 W 802.11ax HE20 : 16.90 dBm / 0.0490 W 802.11ax HE40 : 17.00 dBm / 0.0501 W 802.11ax HE80 : 16.90 dBm / 0.0490 W <Ant. 2> 802.11a : 17.00 dBm / 0.0501 W 802.11n HT20 : 17.10 dBm / 0.0513 W 802.11n HT40 : 16.90 dBm / 0.0490 W 802.11ac VHT20: 17.20 dBm / 0.0525 W 802.11ac VHT40: 17.00 dBm / 0.0501 W 802.11ac VHT80: 16.80 dBm / 0.0479 W 802.11ax HE20 : 17.00 dBm / 0.0501 W 802.11ax HE40 : 17.00 dBm / 0.0501 W 802.11ax HE80 : 17.00 dBm / 0.0501 W MIMO <Ant. 1 + 2> 802.11a : 20.27 dBm / 0.1064 W 802.11n HT20 : 20.22 dBm / 0.1052 W 802.11n HT40 : 19.98 dBm / 0.0995 W 802.11ac VHT20: 20.28 dBm / 0.1067 W 802.11ac VHT40: 20.00 dBm / 0.1000 W 802.11ac VHT80: 20.04 dBm / 0.1009 W 802.11ax HE20 : 20.21 dBm / 0.1050 W 802.11ax HE40 : 20.06 dBm / 0.1014 W 802.11ax HE80 : 19.94 dBm / 0.0986 W</p>
<p>Maximum Output Power to Antenna <TXBF Modes></p>	<p><5180 MHz ~ 5240 MHz> MIMO <Ant. 1 + 2> 802.11ac VHT20: 19.12 dBm / 0.0817 W 802.11ac VHT40: 19.17 dBm / 0.0826 W 802.11ac VHT80: 19.27 dBm / 0.0845 W 802.11ax HE20 : 19.12 dBm / 0.0817 W 802.11ax HE40 : 19.17 dBm / 0.0826 W 802.11ax HE80 : 19.00 dBm / 0.0794 W</p>



Standards-related Product Specification	
<p>99% Occupied Bandwidth <CDD Modes></p>	<p>MIMO <Ant. 1> 802.11a : 16.43 MHz 802.11ac VHT20 : 17.63 MHz 802.11ac VHT40 : 66.73 MHz 802.11ac VHT80 : 77.20 MHz 802.11ax HE20 : 19.08 MHz 802.11ax HE40 : 43.16 MHz 802.11ax HE80 : 77.80 MHz</p> <p>MIMO <Ant. 2> 802.11a : 19.78 MHz 802.11ac VHT20 : 19.33 MHz 802.11ac VHT40 : 67.93 MHz 802.11ac VHT80 : 98.78 MHz 802.11ax HE20 : 23.08 MHz 802.11ax HE40 : 73.53 MHz 802.11ax HE80 : 104.30 MHz</p>
<p>99% Occupied Bandwidth <TXBF Modes></p>	<p>MIMO <Ant. 1> 802.11ac VHT20 : 17.88 MHz 802.11ac VHT40 : 36.66 MHz 802.11ac VHT80 : 77.80 MHz 802.11ax HE20 : 17.83 MHz 802.11ax HE40 : 36.96 MHz 802.11ax HE80 : 77.56 MHz</p> <p>MIMO <Ant. 2> 802.11ac VHT20 : 17.88 MHz 802.11ac VHT40 : 36.96 MHz 802.11ac VHT80 : 76.96 MHz 802.11ax HE20 : 17.78 MHz 802.11ax HE40 : 36.76 MHz 802.11ax HE80 : 82.00 MHz</p>
<p>Type of Modulation</p>	<p>802.11a/n : OFDM (BPSK / QPSK / 16QAM / 64QAM) 802.11ac : OFDM (BPSK / QPSK / 16QAM / 64QAM / 256QAM) 802.11ax: OFDM (BPSK / QPSK / 16QAM / 64QAM / 256QAM / 1024QAM)</p>



Standards-related Product Specification			
Antenna Type / Gain	<5180 MHz ~ 5240 MHz>		
	Ant. 1 : ILA Antenna with gain 1.50 dBi Ant. 2 : ILA Antenna with gain 1.30 dBi		
Antenna Type / Gain	<5260 MHz ~ 5320 MHz>		
	Ant. 1 : ILA Antenna with gain 1.50 dBi Ant. 2 : ILA Antenna with gain 1.30 dBi		
Antenna Type / Gain	<5500 MHz ~ 5700 MHz >		
	Ant. 1 : ILA Antenna with gain 1.50 dBi Ant. 2 : ILA Antenna with gain 1.30 dBi		
Antenna Function Description		Ant. 1	Ant. 2
	802.11 a/n/ac/ax	V	V
	802.11 a/n/ac/ax MIMO	V	V
	802.11 ac/ax TXBF	V	V

Note: MIMO Ant. 1+2 is a calculated result from sum of the power MIMO Ant. 1 and MIMO Ant. 2.

1.3 Modification of EUT

No modifications are made to the EUT during all test items.



1.4 Testing Location

Test Site	SPORTON INTERNATIONAL INC. EMC & Wireless Communications Laboratory	
Test Site Location	No.52, Huaya 1st Rd., Guishan Dist., Taoyuan City, Taiwan (R.O.C.) TEL: +886-3-327-3456 FAX: +886-3-328-4978	
Test Site No.	Sporton Site No.	
	TH05-HY	CO05-HY

Note: The test site complies with ANSI C63.4 2014 requirement.

Test Site	SPORTON INTERNATIONAL INC. EMC & Wireless Communications Laboratory	
Test Site Location	No.58, Aly. 75, Ln. 564, Wenhua 3rd, Rd., Guishan Dist., Taoyuan City, Taiwan (R.O.C.) TEL: +886-3-327-0868 FAX: +886-3-327-0855	
Test Site No.	Sporton Site No.	
	03CH11-HY	03CH13-HY

Note: The test site complies with ANSI C63.4 2014 requirement.

FCC designation No.: TW1190 and TW0007

1.5 Applicable Standards

According to the specifications of the manufacturer, the EUT must comply with the requirements of the following standards:

- ♦ FCC Part 15 Subpart E
- ♦ FCC KDB 789033 D02 General UNII Test Procedures New Rules v02r01.
- ♦ FCC KDB 414788 D01 Radiated Test Site v01r01.
- ♦ FCC KDB 662911 D01 Multiple Transmitter Output v02r01.
- ♦ ANSI C63.10-2013

Remark:

1. All test items were verified and recorded according to the standards and without any deviation during the test.
2. This EUT has also been tested and complied with the requirements of FCC Part 15, Subpart B, recorded in a separate test report.



2 Test Configuration of Equipment Under Test

- a. The EUT has been associated with peripherals and configuration operated in a manner tended to maximize its emission characteristics in a typical application. Frequency range investigated: conduction emission (150 kHz to 30 MHz), radiation emission (9 kHz to the 10th harmonic of the highest fundamental frequency or to 40 GHz, whichever is lower). For radiated measurement, pre-scanned in three orthogonal panels, X, Y, Z. The worst cases (For B1: X Plane for 802.11ax TXBF Mode, Y plane for 802.11 a/n/ac and TXBF Mode, Z Plane for 802.11ax Mode; For B2~3: Y plane for 802.11 a/n/ac and WPC Mode, Z Plane for 802.11ax Mode) were recorded in this report.
- b. AC power line Conducted Emission was tested under maximum output power.

2.1 Carrier Frequency and Channel

Frequency Band	Channel	Freq. (MHz)	Channel	Freq. (MHz)
5150-5250 MHz Band 1 (U-NII-1)	36	5180	44	5220
	38*	5190	46*	5230
	40	5200	48	5240
	42 [#]	5210		
5250-5350 MHz Band 2 (U-NII-2A)	52	5260	60	5300
	54*	5270	62*	5310
	56	5280	64	5320
	58 [#]	5290		
5470-5725 MHz Band 3 (U-NII-2C)	100	5500	112	5560
	102*	5510	116	5580
	104	5520	132	5660
	106 [#]	5530	134*	5670
	108	5540	136	5680
	110*	5550	140	5700



Frequency Band	Channel	Freq. (MHz)	Channel	Freq. (MHz)
TDWR Channel	118*	5590	124	5620
	120	5600	126*	5630
	122 [#]	5610	128	5640

Note:

1. The above Frequency and Channel in "*" were 802.11n HT40 and 802.11ac VHT40.
2. The above Frequency and Channel in "[#]" were 802.11ac VHT80.

2.2 Test Mode

Final test modes are considering the modulation and worse data rates as below table.

MIMO Mode

Modulation	Data Rate
802.11a	6 Mbps
802.11n HT20 (Covered by VHT20)	MCS0
802.11n HT40 (Covered by VHT40)	MCS0
802.11ac VHT20	MCS0
802.11ac VHT40	MCS0
802.11ac VHT80	MCS0
802.11ax HE20	MCS0
802.11ax HE40	MCS0
802.11ax HE80	MCS0

TXBF Mode

Modulation	Data Rate
802.11ac VHT20	MCS0
802.11ac VHT40	MCS0
802.11ac VHT80	MCS0
802.11ax HE20	MCS0
802.11ax HE40	MCS0
802.11ax HE80	MCS0



Test Cases	
AC Conducted Emission	Mode 1 : GSM850 Idle + Bluetooth Link + WLAN (5GHz) Link + MPEG4 + Earphone + Battery + USB Cable 1 (Charging from Adapter 1)
Remark: For Radiated Test Cases, the tests were performed with Adapter 1 and USB Cable 1.	

Ch. #		Band I : 5150-5250 MHz	Band II : 5250-5350 MHz	Band III : 5470-5725MHz
		802.11a	802.11a	802.11a
L	Low	36	52	100
M	Middle	44	60	116
H	High	48	64	140

Ch. #		Band I : 5150-5250 MHz	Band II : 5250-5350 MHz	Band III : 5470-5725MHz
		802.11ac VHT20	802.11ac VHT20	802.11ac VHT20
L	Low	36	52	100
M	Middle	44	60	116
H	High	48	64	140

Ch. #		Band I : 5150-5250 MHz	Band II : 5250-5350 MHz	Band III : 5470-5725MHz
		802.11ac VHT40	802.11ac VHT40	802.11ac VHT40
L	Low	38	54	102
M	Middle	-	-	110
H	High	46	62	134

Ch. #		Band I : 5150-5250 MHz	Band II : 5250-5350 MHz	Band III : 5470-5725MHz
		802.11ac VHT80	802.11ac VHT80	802.11ac VHT80
L	Low	-	-	106
M	Middle	42	58	-
H	High	-	-	122



Ch. #		Band I : 5150-5250 MHz	Band II : 5250-5350 MHz	Band III : 5470-5725MHz
		802.11ax HE20	802.11ax HE20	802.11ax HE20
L	Low	36	52	100
M	Middle	44	60	116
H	High	48	64	140

Ch. #		Band I : 5150-5250 MHz	Band II : 5250-5350 MHz	Band III : 5470-5725MHz
		802.11ax HE40	802.11ax HE40	802.11ax HE40
L	Low	38	54	102
M	Middle	-	-	110
H	High	46	62	134

Ch. #		Band I : 5150-5250 MHz	Band II : 5250-5350 MHz	Band III : 5470-5725MHz
		802.11ax HE80	802.11ax HE80	802.11ax HE80
L	Low	-	-	106
M	Middle	42	58	-
H	High	-	-	122

Remark: For radiation spurious emission, the final modulation and the worst data rate was reference the max RF conducted power.

2.3 Connection Diagram of Test System

<WLAN Tx Mode>

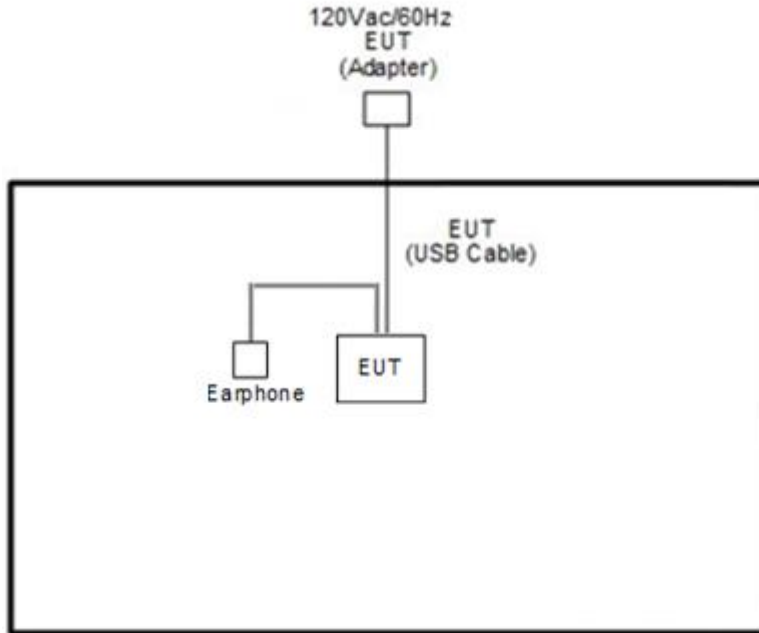

<TXBF Mode>

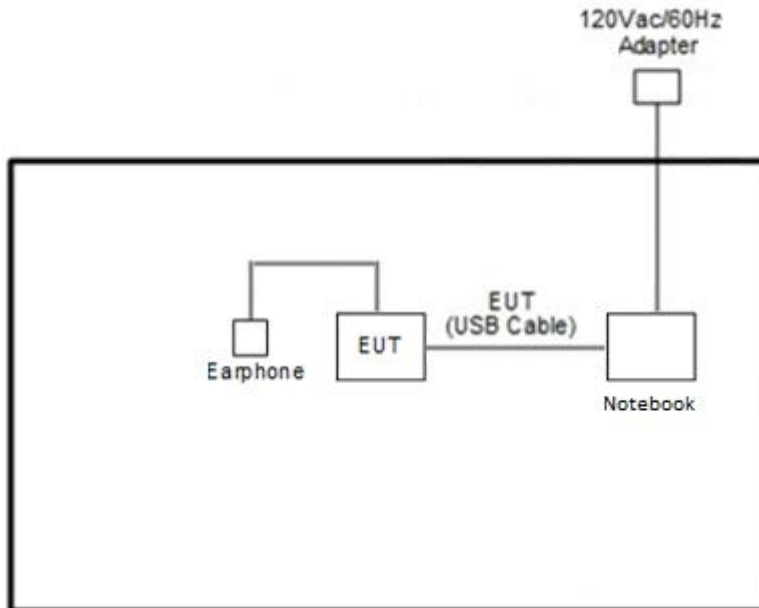

<WPC Mode>

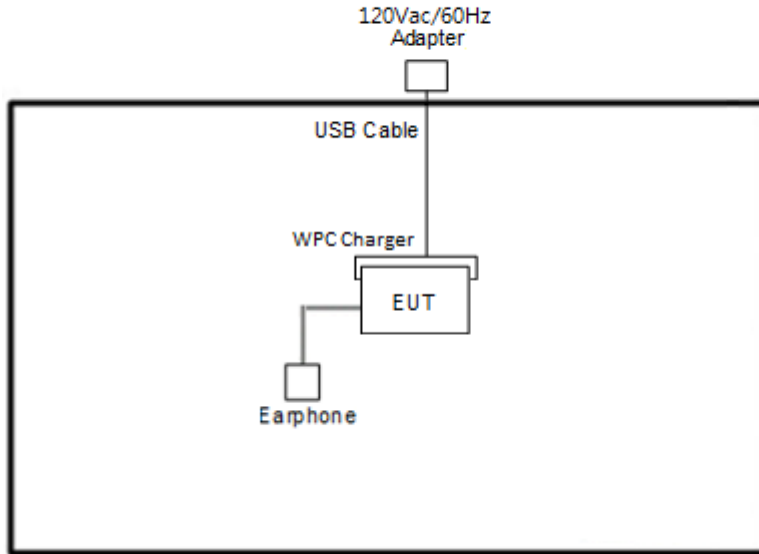

<AC Conducted Emission Mode>

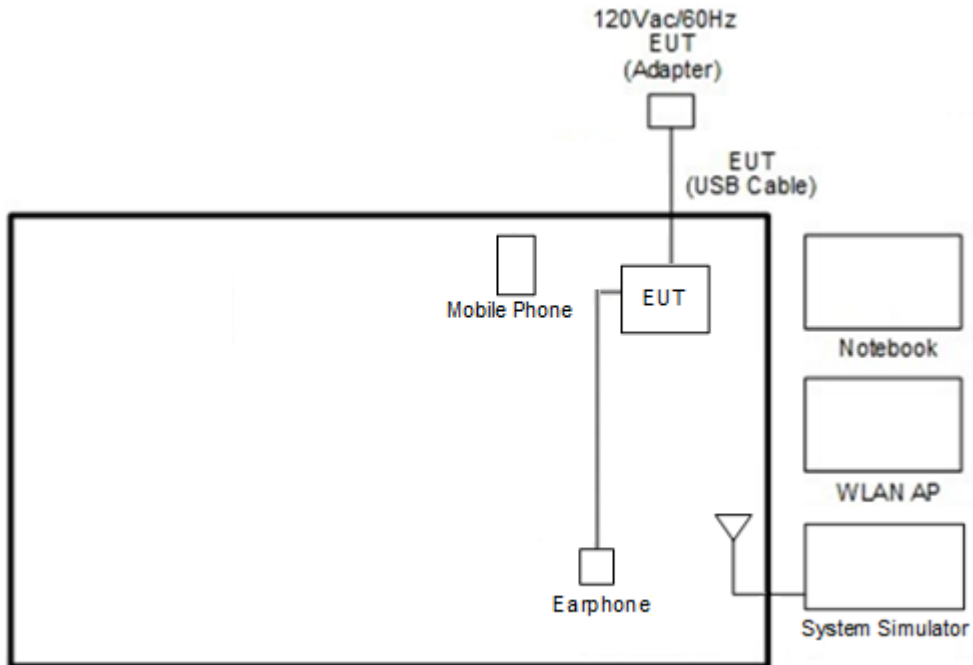



2.4 Support Unit used in test configuration and system

Item	Equipment	Trade Name	Model Name	FCC ID	Data Cable	Power Cord
1.	System Simulator	R&S	CMU 200	N/A	N/A	Unshielded, 1.8 m
2.	WLAN AP	ASUS	RT-AC66U	MSQ-RTAC66U	N/A	Unshielded, 1.8 m
3.	Notebook	DELL	Latitude E3400	FCC DoC	N/A	AC I/P: Unshielded, 1.2 m DC O/P: Shielded, 1.8 m
4.	Mobile Phone	Moto	moto burton	N/A	N/A	N/A
5.	Earphone	Moto	NASH38C16618	N/A	Unshielded, 1.0 m	N/A
6.	Wireless Charger Stand	Samsung	EP-N5200	N/A	N/A	N/A
7.	Adapter	N/A	N/A	N/A	N/A	N/A
8.	USB Cable	N/A	N/A	N/A	N/A	N/A

2.5 EUT Operation Test Setup

The RF test items, utility “QRCT v4.0.00142.0” was installed in Notebook which was programmed in order to make the EUT get into the engineering modes to provide channel selection, power level, data rate and the application type and for continuous transmitting signals.

For TXBF mode, the modulation modes and data rates manipulated by the command lines in the engineering program made the EUT link to another EUT by power under the normal operation. The “QRCT V4.0.00142.0” software tool was used to enable the EUT to transmit signals continuously.

2.6 Measurement Results Explanation Example

For all conducted test items:

The offset level is set in the spectrum analyzer to compensate the RF cable loss and attenuator factor between EUT conducted output port and spectrum analyzer. With the offset compensation, the spectrum analyzer reading level is exactly the EUT RF output level.

Example :

The spectrum analyzer offset is derived from RF cable loss and attenuator factor.

Offset = RF cable loss + attenuator factor.

Following shows an offset computation example with cable loss 4.2 dB and 10dB attenuator.

$$\begin{aligned} \text{Offset(dB)} &= \text{RF cable loss(dB)} + \text{attenuator factor(dB)}. \\ &= 4.2 + 10 = 14.2 \text{ (dB)} \end{aligned}$$

3 Test Result

3.1 26dB & 99% Occupied Bandwidth Measurement

3.1.1 Description of 26dB & 99% Occupied Bandwidth

This section is for reporting purpose only.

There is no restriction limits for bandwidth.

3.1.2 Measuring Instruments

See list of measuring equipment of this test report.

3.1.3 Test Procedures

1. The testing follows FCC KDB 789033 D02 General UNII Test Procedures New Rules v02r01. Section C) Emission bandwidth
2. Set RBW = approximately 1% of the emission bandwidth.
3. Set the VBW > RBW.
4. Detector = Peak.
5. Trace mode = max hold
6. Measure the maximum width of the emission that is 26 dB down from the peak of the emission. Compare this with the RBW setting of the analyzer. Readjust RBW and repeat measurement as needed until the RBW/EBW ratio is approximately 1%.
7. For 99% Bandwidth Measurement, the spectrum analyzer's resolution bandwidth (RBW) is set 1-5% of the emission bandwidth and set the Video bandwidth (VBW) $\geq 3 * RBW$.
8. Measure and record the results in the test report.

3.1.4 Test Setup

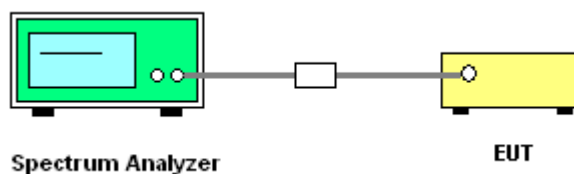

3.1.5 Test Result of 26dB & 99% Occupied Bandwidth

Please refer to Appendix A.

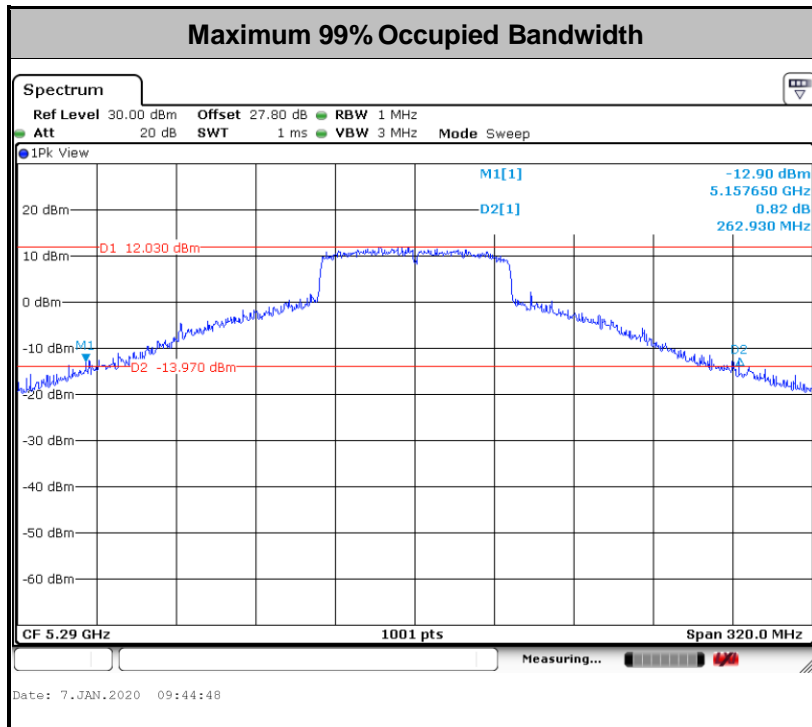
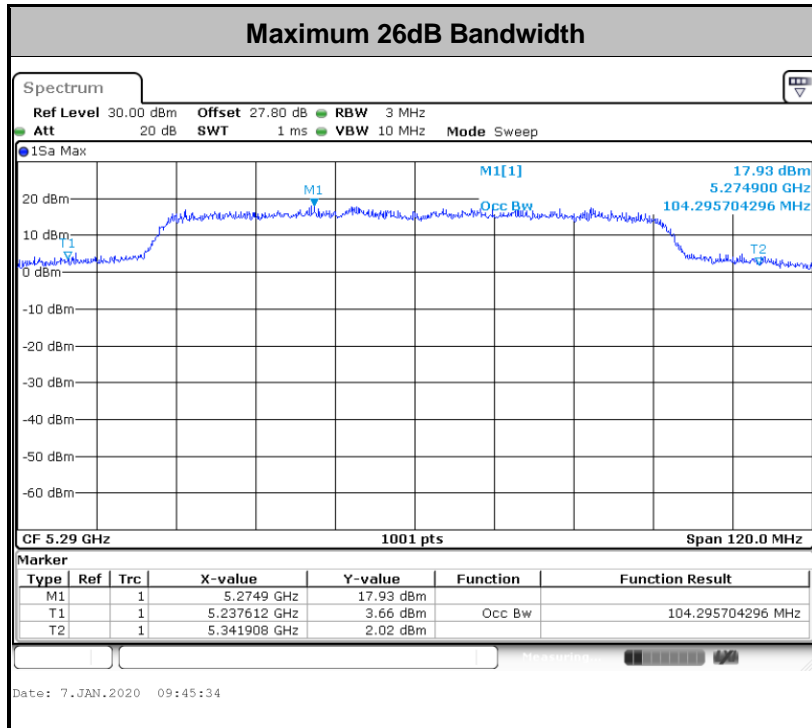

Note: The occupied channel bandwidth is maintained within the band of operation for all of the modulations.



<TXBF Modes>

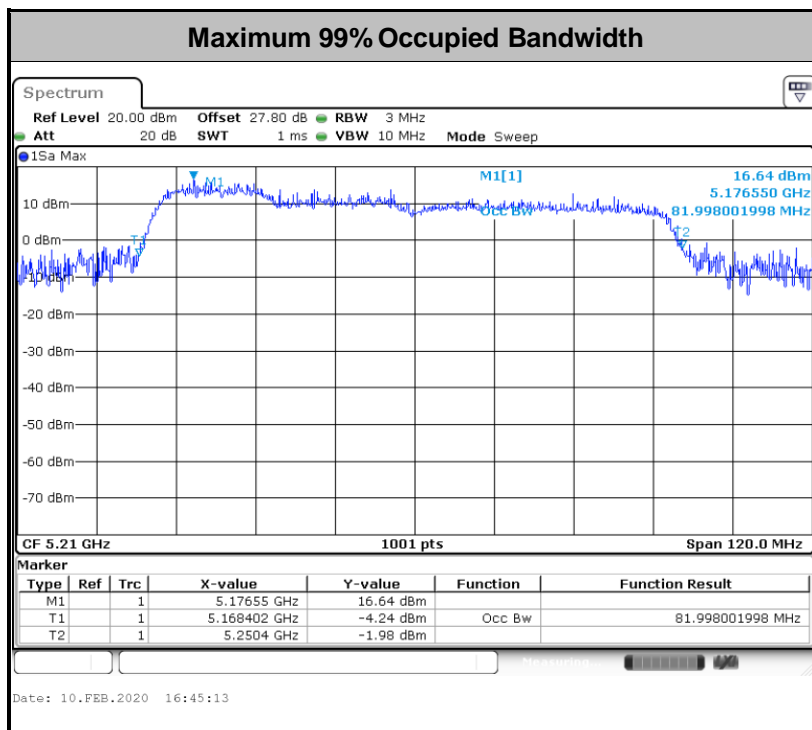
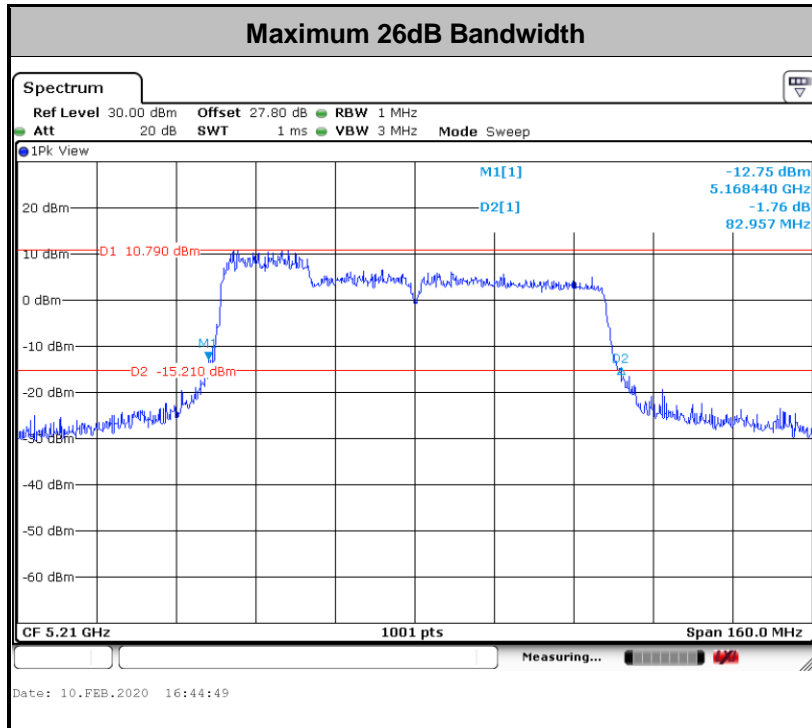

Note: The occupied channel bandwidth is maintained within the band of operation for all of the modulations.



3.2 Maximum Conducted Output Power Measurement

3.2.1 Limit of Maximum Conducted Output Power

<FCC 14-30 CFR 15.407>

For the 5.15–5.25 GHz bands:

- For mobile and portable client devices in the 5.15–5.25 GHz band, the maximum conducted output power over the frequency band of operation shall not exceed 250 mW. For an indoor access point operating in the band 5.15-5.25 GHz, the maximum conducted output power over the frequency band of operation shall not exceed 1 W.

For the 5.25–5.725 GHz bands:

- The maximum conducted output power over the frequency bands of operation shall not exceed the lesser of 250 mW or $11 \text{ dBm} + 10 \log B$, where B is the 26 dB emission bandwidth in megahertz.

If transmitting antennas of directional gain greater than 6 dBi are used, the peak output power shall be reduced by the amount in dB that the directional gain of the antenna exceeds 6 dBi.

Note that U-NII-2 band, devices with a maximum e.i.r.p. greater than 500 mW shall implement TPC in order to have the capability to operate at least 6 dB below the maximum permitted e.i.r.p. of 1 W.

3.2.2 Measuring Instruments

See list of measuring equipment of this test report.

3.2.3 Test Procedures

The testing follows Method PM-G of FCC KDB 789033 D02 General UNII Test Procedures New Rules v02r01.

Method PM-G (Measurement using an RF average power meter):

1. Measurement is performed using a wideband RF power meter.
2. The EUT is configured to transmit at its maximum power control level.
3. Measure the average power of the transmitter
4. Since the measurement is made only during the ON time of the transmitter, no duty cycle correction factor is required.

3.2.4 Test Setup

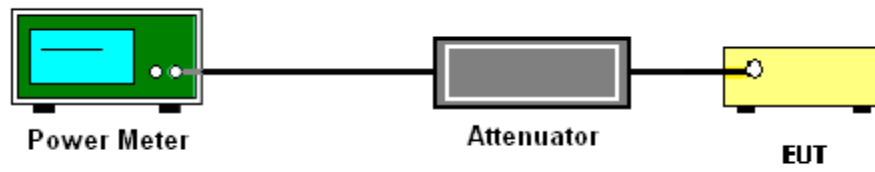

3.2.5 Test Result of Maximum Conducted Output Power

Please refer to Appendix A.



3.3 Power Spectral Density Measurement

3.3.1 Limit of Power Spectral Density

<FCC 14-30 CFR 15.407>

For the 5.15–5.25 GHz bands:

For mobile and portable client devices in the 5.15–5.25 GHz band, the maximum power spectral density shall not exceed 11 dBm in any 1.0 MHz band. For an indoor access point operating in the band 5.15-5.25 GHz, the maximum power spectral density shall not exceed 17 dBm in any 1.0 MHz band.

For the 5.25–5.725 GHz bands:

The maximum power spectral density shall not exceed 11 dBm in any 1.0 MHz band.

For Straddle Channel, according to KDB 789033 D02 General UNII Test Procedures New Rules v02r01, if the power and PSD of the devices are uniform and comply with the lower limits specified for the U-NII-2 bands, a single measurement over the entire emission bandwidth can be performed to show compliance.

If transmitting antennas of directional gain greater than 6 dBi are used, the peak output power shall be reduced by the amount in dB that the directional gain of the antenna exceeds 6 dBi.

3.3.2 Measuring Instruments

See list of measuring equipment of this test report.



3.3.3 Test Procedures

The testing follows FCC KDB 789033 D02 General UNII Test Procedures New Rules v02r01.
Section F) Maximum power spectral density.

Method SA-3

(power averaging (rms) detection with max hold):

- Set span to encompass the entire emission bandwidth (EBW) of the signal.
 - Set RBW = 1 MHz.
 - Set VBW \geq 3 MHz
 - Number of points in sweep \geq 2 Span / RBW.
 - Sweep time \leq (number of points in sweep) \times T, when duty cycle is less than 98 percent where T is the minimum transmission duration over which the transmitter is on and is transmitting at its maximum power control level for the tested mode of operation.
 - Detector = power averaging (rms).
 - Trace mode = max hold.
 - Allow max hold to run for at least 60 seconds, or longer as needed to allow the trace to stabilize.
1. The RF output of EUT was connected to the spectrum analyzer by a low loss cable.
 2. Each plot has already offset with cable loss, and attenuator loss. Measure the PPSD and record it.
 3. For MIMO mode, calculation method follows FCC KDB 662911 D01 Multiple Transmitter Output v02r01.

Method (a): Measure and sum the spectra across the outputs.

The total final Power Spectral Density is from a device with 2 transmitter outputs. The spectrum measurements of the individual outputs are all performed with the same span and number of points; the spectrum value in the first spectral bin of output 1 is summed with that in the first spectral bin of output 2 to obtain the value for the first frequency bin of the summed spectrum.

3.3.4 Test Setup

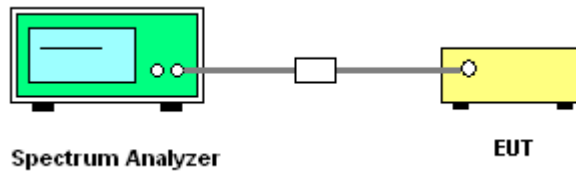

3.3.5 Test Result of Power Spectral Density

Please refer to Appendix A.



<CDD Modes>

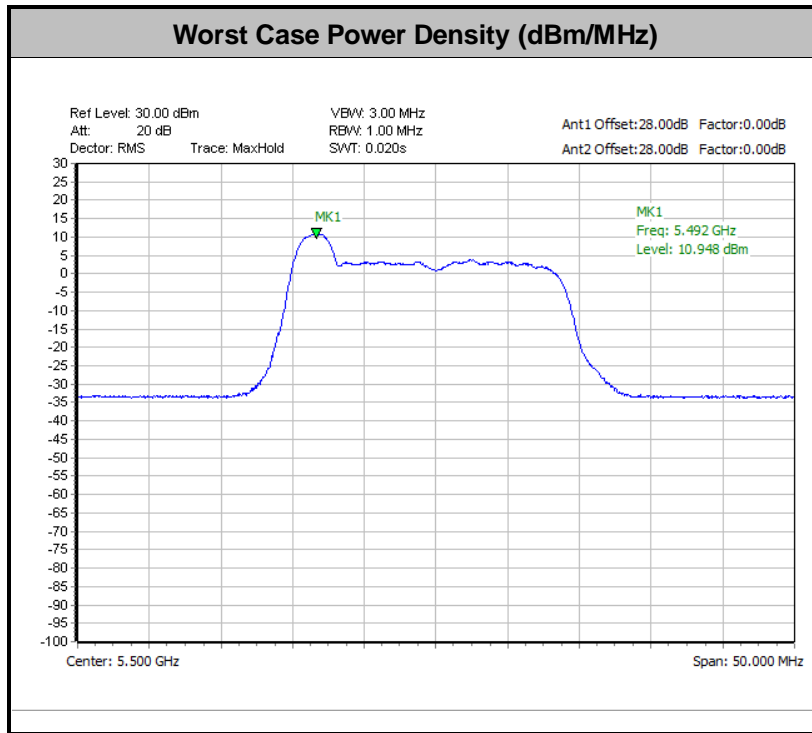

<TXBF Modes>

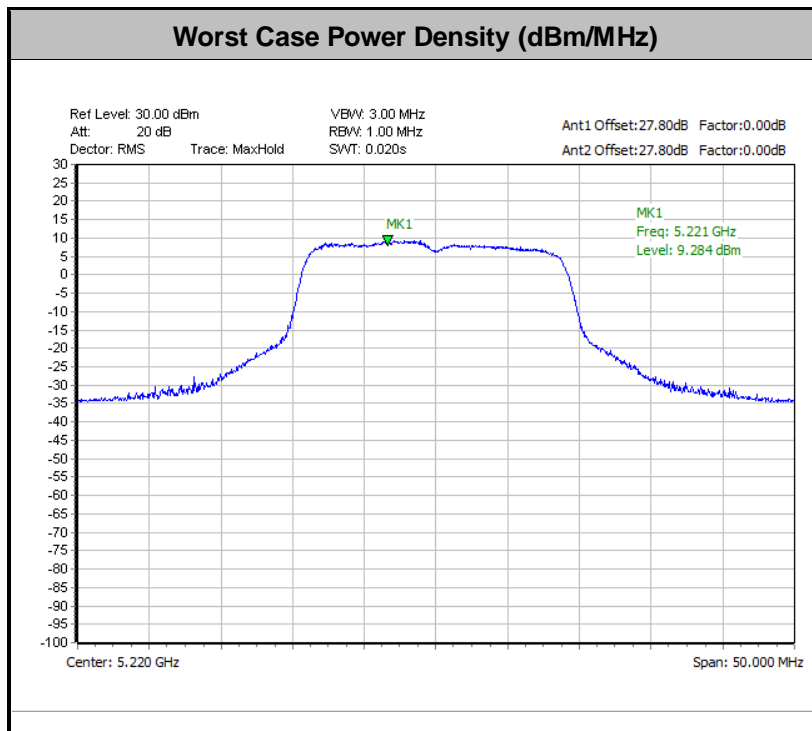



3.4 Unwanted Emissions Measurement

This section is to measure unwanted emissions through radiated measurement for band edge spurious emissions and out of band emissions measurement.

3.4.1 Limit of Unwanted Emissions

- (1) For transmitters operating in the 5150-5250 MHz band: all emissions outside of the 5150-5350 MHz band shall not exceed an EIRP of -27dBm/MHz.

For transmitters operating in the 5250-5350 MHz band: all emissions outside of the 5150-5350 MHz band shall not exceed an EIRP of -27 dBm/MHz. Devices operating in the 5250-5350 MHz band that generate emissions in the 5150-5250 MHz band must meet all applicable technical requirements for operation in the 5150-5250 MHz band (including indoor use) or alternatively meet an out-of-band emission EIRP limit of -27 dBm/MHz in the 5150-5250 MHz band.

For transmitters operating in the 5470-5600 MHz and 5650-5725MHz band: all emissions outside of the 5470-5600 MHz and 5650-5725MHz band shall not exceed an EIRP of -27 dBm/MHz.

- (2) Unwanted spurious emissions fallen in restricted bands shall comply with the general field strength limits as below table:

Frequency (MHz)	Field Strength (microvolts/meter)	Measurement Distance (meters)
0.009 – 0.490	2400/F(kHz)	300
0.490 – 1.705	24000/F(kHz)	30
1.705 – 30.0	30	30
30 – 88	100	3
88 – 216	150	3
216 - 960	200	3
Above 960	500	3

Note: The following formula is used to convert the EIRP to field strength.

$$E = \frac{1000000\sqrt{30P}}{3} \text{ } \mu\text{V/m, where P is the eirp (Watts)}$$



EIRP (dBm)	Field Strength at 3m (dBμV/m)
- 27	68.3

(3) KDB789033 D02 v02r01 G)2)c)

- (i) Sections 15.407(b)(1-3) specifies the unwanted emissions limit for the U-NII-1 and U-NII-2 bands. As specified, emissions above 1000 MHz that are outside of the restricted bands are subject to a peak emission limit of -27 dBm/MHz.
- (ii) Section 15.407(b)(4) specifies the unwanted emissions limit for the U-NII-3 band. A band emissions mask is specified in Section 15.407(b)(4)(i). The emission limits are based on the use of a peak detector.

3.4.2 Measuring Instruments

See list of measuring equipment of this test report.

3.4.3 Test Procedures

1. The testing follows FCC KDB 789033 D02 General UNII Test Procedures New Rules v02r01. Section G) Unwanted emissions measurement.

(1) Procedure for Unwanted Emissions Measurements Below 1000MHz

- RBW = 120 kHz
- VBW = 300 kHz
- Detector = Peak
- Trace mode = max hold

(2) Procedure for Peak Unwanted Emissions Measurements Above 1000 MHz

- RBW = 1 MHz
- VBW ≥ 3 MHz
- Detector = Peak
- Sweep time = auto
- Trace mode = max hold



(3) Procedures for Average Unwanted Emissions Measurements Above 1000MHz

- RBW = 1 MHz
 - VBW = 10 Hz, when duty cycle is no less than 98 percent.
 - $VBW \geq 1/T$, when duty cycle is less than 98 percent where T is the minimum transmission duration over which the transmitter is on and is transmitting at its maximum power control level for the tested mode of operation.
2. The EUT was placed on a turntable with 0.8 meter for frequency below 1GHz and 1.5 meter for frequency above 1GHz respectively above ground.
 3. The EUT was set 3 meters from the interference receiving antenna which was mounted on the top of a variable height antenna tower.
 4. The antenna is a broadband antenna and its height is adjusted between one meter and four meters above ground to find the maximum value of the field strength for both horizontal polarization and vertical polarization of the antenna.
 5. For each suspected emission, the EUT was arranged to its worst case and then adjust the antenna tower (from 1 m to 4 m) and turntable (from 0 degree to 360 degrees) to find the maximum reading.
 6. For testing below 1GHz, if the emission level of the EUT in peak mode was 3 dB lower than the limit specified, then peak values of EUT will be reported, otherwise, the emissions will be repeated one by one using the CISPR quasi-peak method and reported.
 7. For testing above 1GHz, the emission level of the EUT in peak mode was 20dB lower than average limit (that means the emission level in average mode also complies with the limit in average mode), then peak values of EUT will be reported, otherwise, the emissions will be measured in average mode again and reported.

3.4.4 Test Setup

For radiated emissions below 30MHz

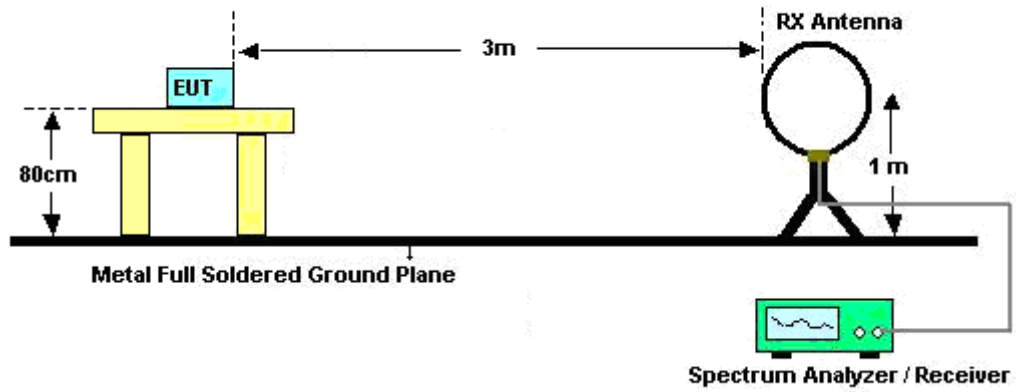

For radiated emissions from 30MHz to 1GHz

<CDD Mode>

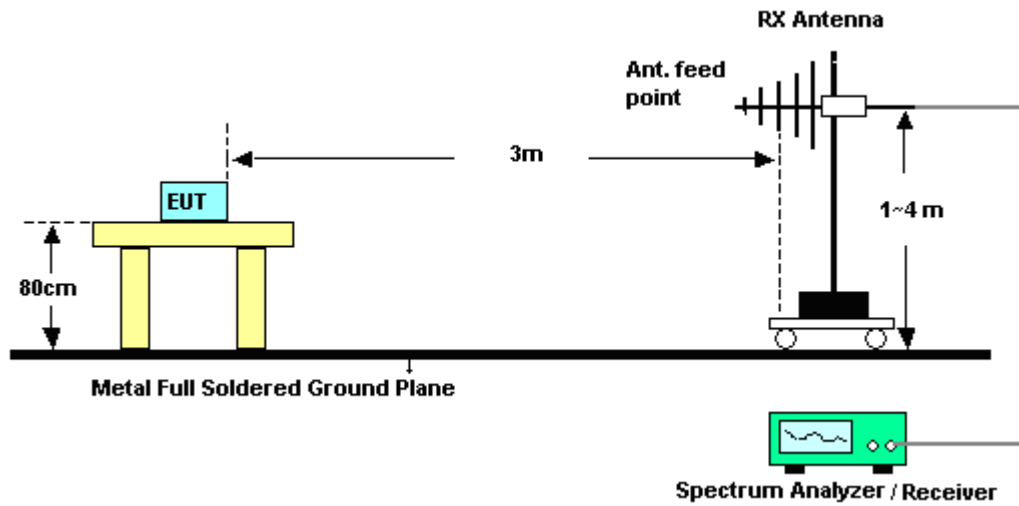

<TXBF Modes>

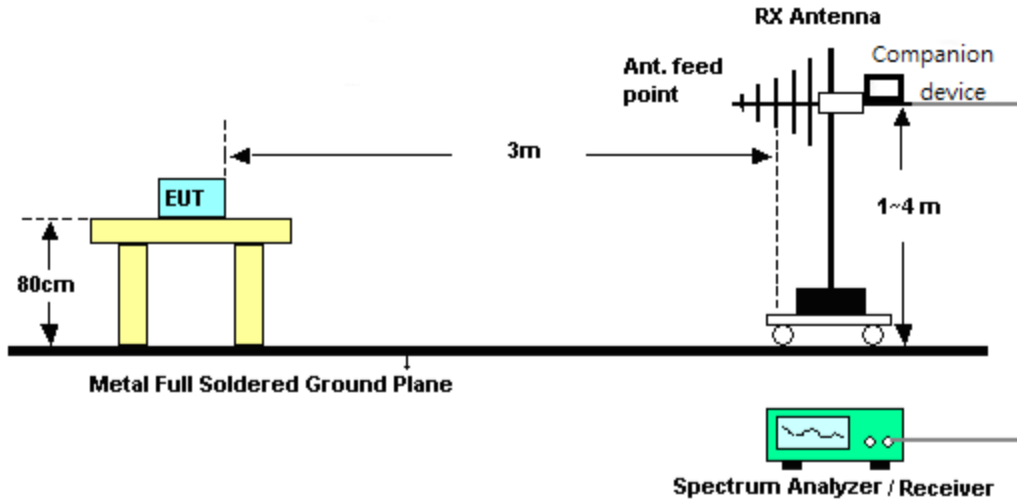

For radiated emissions above 1GHz

<CDD Mode>

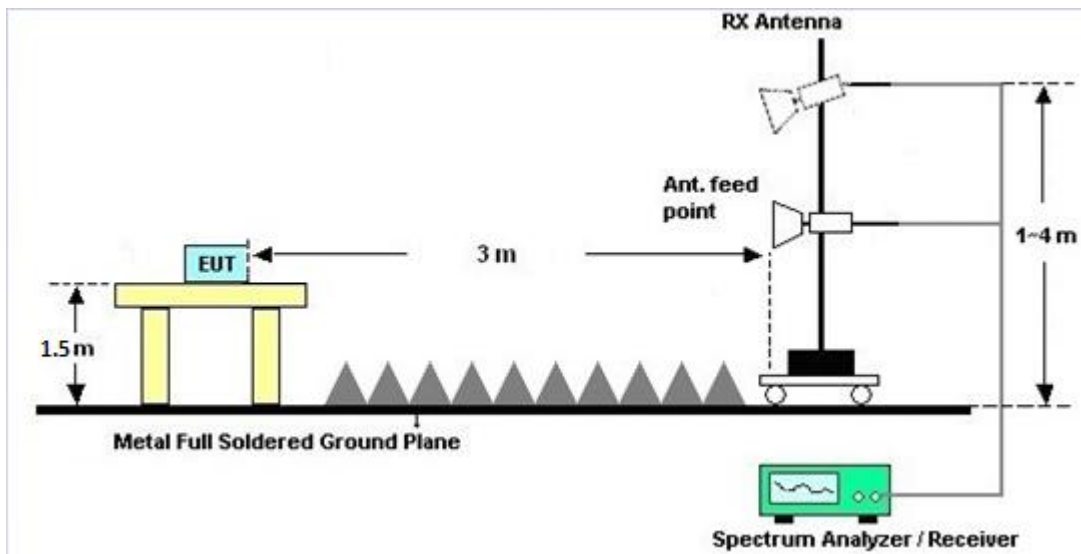

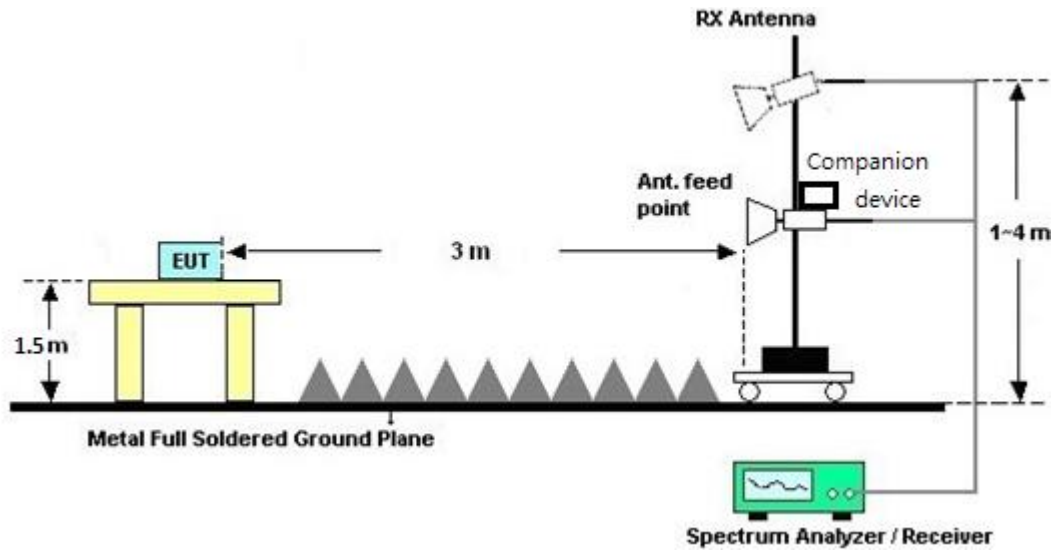
<TXBF Modes>**3.4.5 Test Results of Radiated Spurious Emissions (9 kHz ~ 30 MHz)**

The low frequency, which started from 9 kHz to 30MHz, was pre-scanned and the result which was 20dB lower than the limit line was not reported.

There is a comparison data of both open-field test site and alternative test site - semi-Anechoic chamber according to 414788 D01 Radiated Test Site v01r01, and the result came out very similar.

3.4.6 Test Result of Radiated Spurious at Band Edges

Please refer to Appendix C and D.

3.4.7 Duty Cycle

Please refer to Appendix E.

3.4.8 Test Result of Radiated Spurious Emissions (30MHz ~ 10th Harmonic)

Please refer to Appendix C and D.



3.5 AC Conducted Emission Measurement

3.5.1 Limit of AC Conducted Emission

For equipment that is designed to be connected to the public utility (AC) power line, the radio frequency voltage that is conducted back onto the AC power line on any frequency or frequencies within the band 150 kHz to 30 MHz shall not exceed the limits in the following table.

Frequency of emission (MHz)	Conducted limit (dB μ V)	
	Quasi-peak	Average
0.15-0.5	66 to 56*	56 to 46*
0.5-5	56	46
5-30	60	50

*Decreases with the logarithm of the frequency.

3.5.2 Measuring Instruments

See list of measuring equipment of this test report.

3.5.3 Test Procedures

1. The EUT was placed 0.4 meter from the conducting wall of the shielding room was kept at least 80 centimeters from any other grounded conducting surface.
2. Connect EUT to the power mains through a line impedance stabilization network (LISN).
3. All the support units are connecting to the other LISN.
4. The LISN provides 50 ohm coupling impedance for the measuring instrument.
5. The FCC states that a 50 ohm, 50 microhenry LISN should be used.
6. Both sides of AC line were checked for maximum conducted interference.
7. The frequency range from 150 kHz to 30 MHz was searched.
8. Set the test-receiver system to Peak Detect Function and specified bandwidth with Maximum Hold Mode.

3.5.4 Test Setup

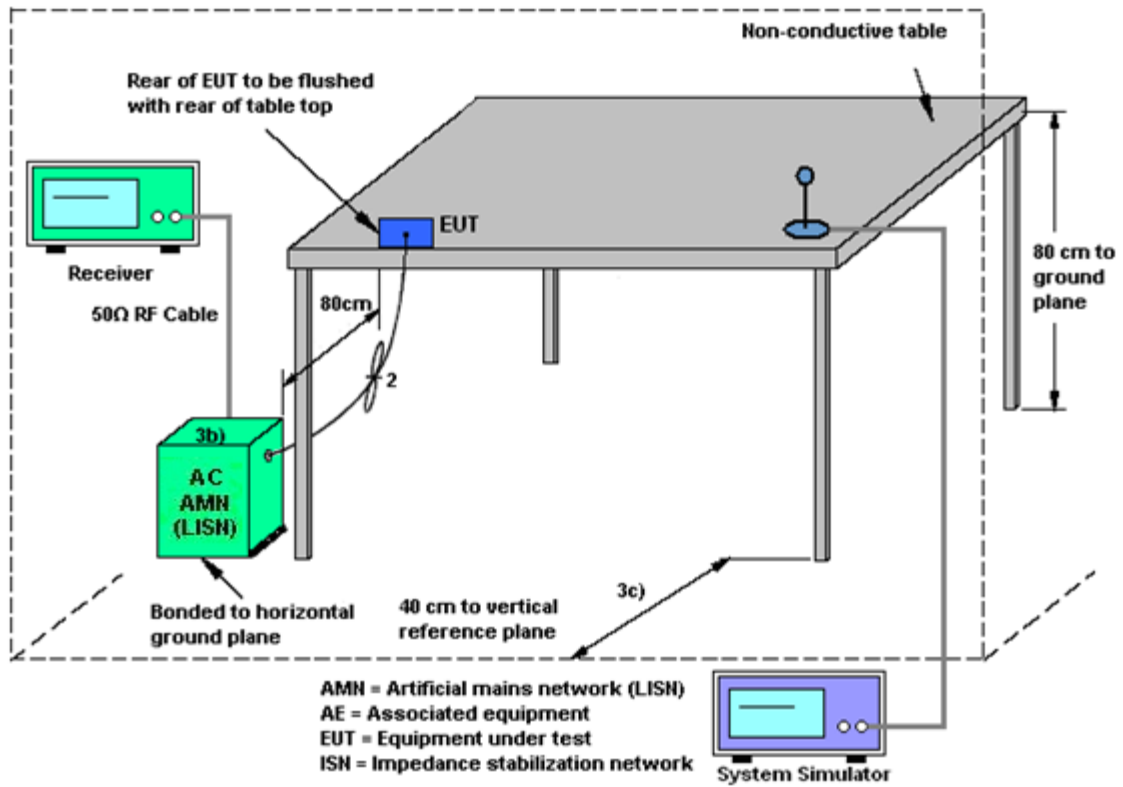

3.5.5 Test Result of AC Conducted Emission

Please refer to Appendix B.



3.6 Automatically Discontinue Transmission

3.6.1 Limit of Automatically Discontinue Transmission

The device shall automatically discontinue transmission in case of either absence of information to transmit or operational failure. These provisions are not intended to preclude the transmission of control or signaling information or the use of repetitive codes used by certain digital technologies to complete frame or burst intervals. Applicants shall include in their application for equipment authorization to describe how this requirement is met.

3.6.2 Measuring Instruments

See list of measuring equipment of this test report.

3.6.3 Test Result of Automatically Discontinue Transmission

EUT is verified this characteristic during the function check of normal sample associated with an access point:

- A. Information start: make EUT supply information to the access point.
- B. Information stop: stop supplying information to the access point.

While the EUT is not transmitting any information, the EUT can automatically discontinue transmission and become standby mode for power saving.

- C. Information start: make EUT supply information to the access point again.

The EUT can detect the controlling signal of ACK message transmitting from remote device and verify whether it shall resend or discontinue transmission.

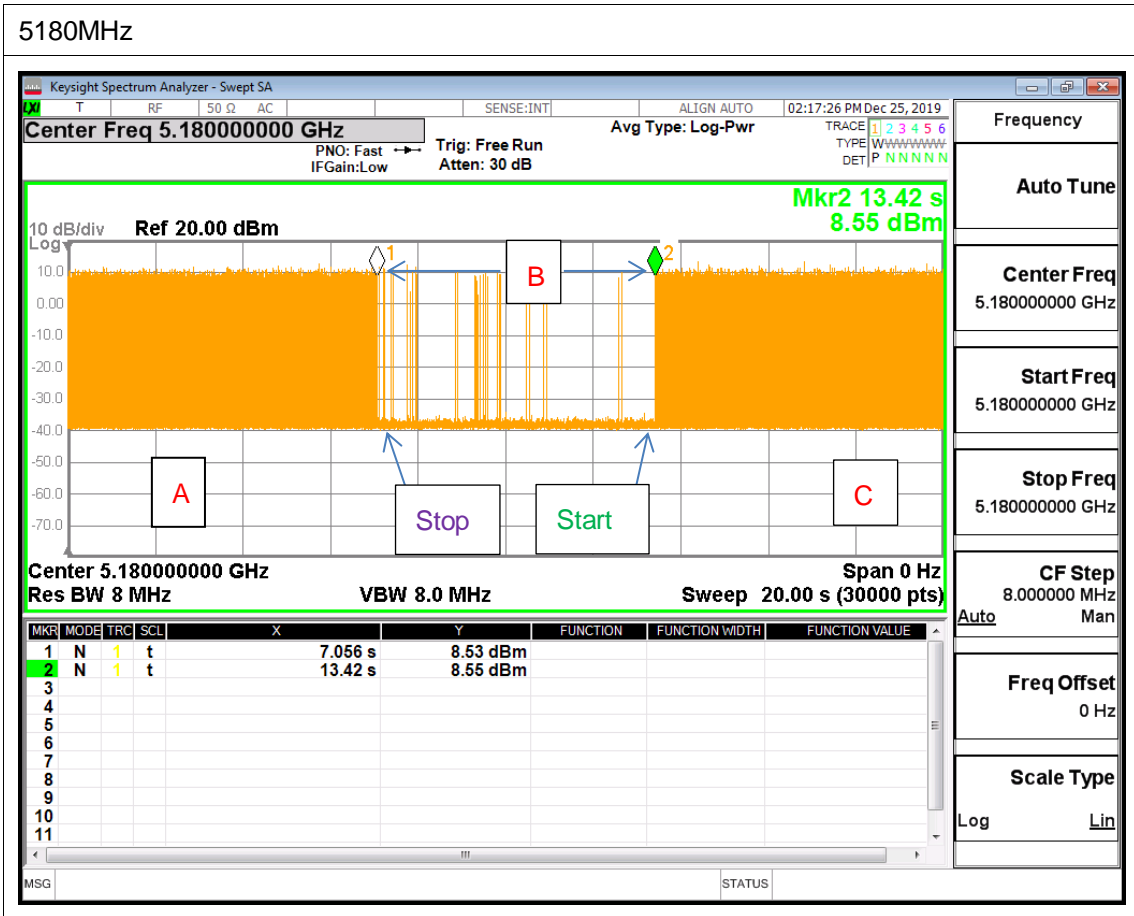

Note : The control / signalling information during the period B is precluded.



3.7 Antenna Requirements

3.7.1 Standard Applicable

If transmitting antenna directional gain is greater than 6 dBi, both the peak transmit power and the peak power spectral density shall be reduced by the amount in dB that the directional gain of the antenna exceeds 6 dBi.

3.7.2 Antenna Anti-Replacement Construction

An embedded-in antenna design is used.

3.7.3 Antenna Gain

<CDD Modes >

FCC KDB 662911 D01 Multiple Transmitter Output v02r01

For CDD transmissions, directional gain is calculated as

Directional gain = GANT + Array Gain, where Array Gain is as follows.

For power spectral density (PSD) measurements on all devices,

Array Gain = 10 log(NANT/NSS=1) dB.

For power measurements on IEEE 802.11 devices,

Array Gain = 0 dB (i.e., no array gain) for NANT ≤ 4.

Directional gain may be calculated by using the formulas applicable to equal gain antennas with GANT set equal to the gain of the antenna having the highest gain;

The EUT supports CDD mode.

For power, the directional gain GANT is set equal to the antenna having the highest gain, i.e., F)2)f)i).

For PSD, the directional gain calculation is following F)2)f)ii) of KDB 662911 D01 v02r01.

The power and PSD limit should be modified if the directional gain of EUT is over 6 dBi,

The directional gain “DG” is calculated as following table.

<CDD Modes>						
			DG	DG	Power	PSD
			for	for	Limit	Limit
	Ant. 1	Ant. 2	Power	PSD	Reduction	Reduction
	(dBi)	(dBi)	(dBi)	(dBi)	(dB)	(dB)
Band I	1.50	1.30	1.50	4.41	0.00	0.00
Band II	1.50	1.30	1.50	4.41	0.00	0.00
Band III	1.50	1.30	1.50	4.41	0.00	0.00

Power limit reduction = Composite gain – 6dBi, (min = 0)

PSD limit reduction = Composite gain + PSD Array gain – 6dBi, (min = 0)

TXBF modes

FCC KDB 662911 D01 Multiple Transmitter Output v02r01

For CDD transmissions, directional gain is calculated as

$$DirectionalGain = 10 \cdot \log \left[\frac{\sum_{j=1}^{N_{SS}} \left\{ \sum_{k=1}^{N_{ANT}} g_{j,k} \right\}^2}{N_{ANT}} \right]$$

where

Each antenna is driven by no more than one spatial stream;

N_{SS} = the number of independent spatial streams of data;

N_{ANT} = the total number of antennas

$g_{j,k} = 10^{G_k/20}$ if the k th antenna is being fed by spatial stream j , or zero if it is not;
 G_k is the gain in dBi of the k th antenna.

The EUT supports beamforming for 802.11ac modes.

The directional gain calculation is following F)2)e)ii) of KDB 662911 D01 v02r01.

The power and PSD limit should be modified if the directional gain of EUT is over 6 dBi,

The directional gain “DG” is calculated as following table.

			DG	DG	Power	PSD
			for	for	Limit	Limit
	Ant 1	Ant 2	Power	PSD	Reduction	Reduction
	(dBi)	(dBi)	(dBi)	(dBi)	(dB)	(dB)
Band I	1.50	1.30	4.41	4.41	0.00	0.00
Band II	1.50	1.30	4.41	4.41	0.00	0.00
Band III	1.50	1.30	4.41	4.41	0.00	0.00

$Power\ Limit\ Reduction = DG(Power) - 6dBi, (min = 0)$

$PSD\ Limit\ Reduction = DG(PSD) - 6dBi, (min = 0)$



4 List of Measuring Equipment

Instrument	Manufacturer	Model No.	Serial No.	Characteristics	Calibration Date	Test Date	Due Date	Remark
AC Power Source	ChainTek	APC-1000W	N/A	N/A	N/A	Jan. 07, 2020	N/A	Conduction (CO05-HY)
EMI Test Receiver	Rohde & Schwarz	ESR3	102388	9kHz~3.6GHz	Nov. 15, 2019	Jan. 07, 2020	Nov. 14, 2020	Conduction (CO05-HY)
Hygrometer	Testo	608-H1	34913912	N/A	Mar. 19, 2019	Jan. 07, 2020	Mar. 18, 2020	Conduction (CO05-HY)
LISN	Rohde & Schwarz	ENV216	100081	9kHz~30MHz	Nov. 15, 2019	Jan. 07, 2020	Nov. 14, 2020	Conduction (CO05-HY)
Software	Rohde & Schwarz	EMC32 V10.30	N/A	N/A	N/A	Jan. 07, 2020	N/A	Conduction (CO05-HY)
LF Cable	HUBER + SUHNER	RG-214/U	LF01	N/A	Jan. 02, 2020	Jan. 07, 2020	Jan. 01, 2021	Conduction (CO05-HY)
Pulse Limiter	Rohde & Schwarz	ESH3-Z2	100851	N/A	Jan. 02, 2020	Jan. 07, 2020	Jan. 01, 2021	Conduction (CO05-HY)
Hygrometer	Testo	608-H2	41410069	N/A	Jun. 17, 2019	Dec. 26, 2019~ Feb. 12, 2020	Jun. 16, 2020	Conducted (TH05-HY)
Power Sensor	DARE	RPR3006W	16I00054S NO10	10MHz~6GHz	Dec. 23, 2019	Dec. 26, 2019~ Feb. 12, 2020	Dec. 22, 2020	Conducted (TH05-HY)
Signal Analyzer	Rohde & Schwarz	FSV40	101566	10Hz~40GHz	Jul. 15, 2019	Dec. 26, 2019~ Feb. 12, 2020	Jul. 14, 2020	Conducted (TH05-HY)
Power Supply	GW Instek	SPS-606	GES84293 1	NA	Aug. 19, 2019	Dec. 26, 2019~ Feb. 12, 2020	Aug. 18, 2020	Conducted (TH05-HY)
Switch Box & RF Cable	Burgeon	ETF-058	EC120838 2	N/A	Mar. 27, 2019	Dec. 26, 2019~ Feb. 12, 2020	Mar. 26, 2020	Conducted (TH05-HY)



Instrument	Manufacturer	Model No.	Serial No.	Characteristics	Calibration Date	Test Date	Due Date	Remark
Horn Antenna	SCHWARZBECK	BBHA 9120 D	9120D-1241	1GHz ~ 18GHz	Jul. 02, 2019	Jan. 05, 2020~ Feb. 11, 2020	Jul. 01, 2020	Radiation (03CH13-HY)
Bilog Antenna	TESEQ	CBL 6111D&00800 N1D01N-06	40103 & 07	30MHz~1GHz	Apr. 30, 2019	Jan. 05, 2020~ Feb. 11, 2020	Apr. 29, 2020	Radiation (03CH13-HY)
SHF-EHF Horn Antenna	SCHWARZBECK	BBHA 9170	BBHA9170 576	18GHz- 40GHz	May 14,2019	Jan. 05, 2020~ Feb. 11, 2020	May 13,2020	Radiation (03CH13-HY)
Preamplifier	Keysight	83017A	MY532701 47	1GHz~26.5GHz	Mar. 15, 2019	Jan. 05, 2020~ Feb. 11, 2020	Mar. 14, 2020	Radiation (03CH13-HY)
Preamplifier	MITEQ	AMF-7D-0010 1800-30-10P	1590074	1GHz~18GHz	May. 20, 2019	Jan. 05, 2020~ Feb. 11, 2020	May. 19, 2020	Radiation (03CH13-HY)
Amplifier	Sonoma-Instrument	310 N	187282	9KHz~1GHz	Dec. 17, 2019	Jan. 05, 2020~ Feb. 11, 2020	Dec. 16, 2020	Radiation (03CH13-HY)
Preamplifier	EMEC	EM18G40G	060715	18GHz ~ 40GHz	Dec. 13, 2019	Jan. 05, 2020~ Feb. 11, 2020	Dec. 12, 2020	Radiation (03CH13-HY)
Hygrometer	TECPEL	DTM-303B	TP150115	N/A	Nov. 08, 2019	Jan. 05, 2020~ Feb. 11, 2020	Nov. 07, 2020	Radiation (03CH13-HY)
RF Cable	HUBER + SUHNER	SUCOFLEX 126E	0030/126E	30M-18G	Feb. 13, 2019	Jan. 05, 2020~ Feb. 11, 2020	Feb. 12, 2020	Radiation (03CH13-HY)
RF Cable	HUBER + SUHNER	SUCOFLEX 104	804793/4	30M-18G	Feb. 13, 2019	Jan. 05, 2020~ Feb. 11, 2020	Feb. 12, 2020	Radiation (03CH13-HY)
RF Cable	HUBER + SUHNER	SUCOFLEX 104	MY24961/ 4	30M-18G	Feb. 13, 2019	Jan. 05, 2020~ Feb. 11, 2020	Feb. 12, 2020	Radiation (03CH13-HY)
RF Cable	HUBER + SUHNER	SUCOFLEX 102	MY2859/2	30M~40GHz	Mar. 13, 2019	Jan. 05, 2020~ Feb. 11, 2020	Mar. 12, 2020	Radiation (03CH13-HY)
RF Cable	HUBER + SUHNER	SUCOFLEX 102	MY4274/2	30M~40GHz	Mar. 13, 2019	Jan. 05, 2020~ Feb. 11, 2020	Mar. 12, 2020	Radiation (03CH13-HY)
Spectrum Analyzer	Keysight	N9010A	MY553705 26	10Hz~44GHz	Mar. 19, 2019	Jan. 05, 2020~ Feb. 11, 2020	Mar. 18, 2020	Radiation (03CH13-HY)
Controller	EMEC	EM1000	N/A	Control Turn table & Ant Mast	N/A	Jan. 05, 2020~ Feb. 11, 2020	N/A	Radiation (03CH13-HY)
Antenna Mast	EMEC	AM-BS-4500- B	N/A	1m~4m	N/A	Jan. 05, 2020~ Feb. 11, 2020	N/A	Radiation (03CH13-HY)
Turn Table	EMEC	TT2000	N/A	0~360 Degree	N/A	Jan. 05, 2020~ Feb. 11, 2020	N/A	Radiation (03CH13-HY)
Software	AUDIX	E3 6.2009-8-24c	RK-001124	N/A	N/A	Jan. 05, 2020~ Feb. 11, 2020	N/A	Radiation (03CH13-HY)
EMI Test Receiver	Keysight	N9038A (MXE)	MY541300 85	20Hz ~ 8.4GHz	Nov. 01, 2019	Jan. 05, 2020~ Feb. 11, 2020	Oct. 31, 2020	Radiation (03CH13-HY)
Filter	Wainwright	WHKX12-270 0-3000-18000 -60SS	SN2	3GHz High Pass Filter	Jul. 14, 2019	Jan. 05, 2020~ Feb. 11, 2020	Jul. 13, 2020	Radiation (03CH13-HY)
Filter	Wainwright	WLK4-1000-1 530-8000-40S S	SN12	1.53GHz Low Pass Filter	Sep. 16, 2019	Jan. 05, 2020~ Feb. 11, 2020	Sep. 15, 2020	Radiation (03CH13-HY)
Filter	Wainwright	WHKX8-5872. 5-6750-18000 -40ST	SN5	6.75GHz High Pass Filter	Mar. 13, 2019	Jan. 05, 2020~ Feb. 11, 2020	Mar. 12, 2020	Radiation (03CH13-HY)



Instrument	Manufacturer	Model No.	Serial No.	Characteristics	Calibration Date	Test Date	Due Date	Remark
Preamplifier	EMCE	EMC184045B	980192	18GHz ~ 40GHz	Aug. 01, 2019	Jan. 16, 2020~ Feb. 11, 2020	Jul. 31, 2020	Radiation (03CH11-HY)
Amplifier	SONOMA	310N	187312	9kHz~1GHz	Dec. 03, 2019	Jan. 16, 2020~ Feb. 11, 2020	Dec. 02, 2020	Radiation (03CH11-HY)
Bilog Antenna	TESEQ	CBL 6111D & N-6-06	35414 & AT-N0602	30MHz~1GHz	Oct. 12, 2019	Jan. 16, 2020~ Feb. 11, 2020	Oct. 11, 2020	Radiation (03CH11-HY)
Horn Antenna	SCHWARZBE CK	BBHA 9120 D	9120D-132 6	1GHz ~ 18GHz	Nov. 04, 2019	Jan. 16, 2020~ Feb. 11, 2020	Nov. 03, 2020	Radiation (03CH11-HY)
Loop Antenna	Rohde & Schwarz	HFH2-Z2	100488	9 kHz~30 MHz	Jan. 09, 2020	Jan. 16, 2020~ Feb. 11, 2020	Jan. 08, 2021	Radiation (03CH11-HY)
Preamplifier	Keysight	83017A	MY532700 80	1GHz~26.5GHz	Nov. 13, 2019	Jan. 16, 2020~ Feb. 11, 2020	Nov. 12, 2020	Radiation (03CH11-HY)
Spectrum Analyzer	Keysight	N9010A	MY542004 86	10Hz ~ 44GHz	Oct. 28, 2019	Jan. 16, 2020~ Feb. 11, 2020	Oct. 27, 2020	Radiation (03CH11-HY)
Controller	EMEC	EM 1000	N/A	Control Turn table & Ant Mast	N/A	Jan. 16, 2020~ Feb. 11, 2020	N/A	Radiation (03CH11-HY)
Antenna Mast	EMEC	AM-BS-4500- B	N/A	1~4m	N/A	Jan. 16, 2020~ Feb. 11, 2020	N/A	Radiation (03CH11-HY)
Turn Table	EMEC	TT 2000	N/A	0~360 Degree	N/A	Jan. 16, 2020~ Feb. 11, 2020	N/A	Radiation (03CH11-HY)
Preamplifier	Jet-Power	JPA00101800 -30-10P	160118000 2	1GHz~18GHz	Aug. 01, 2019	Jan. 16, 2020~ Feb. 11, 2020	Jul. 31, 2020	Radiation (03CH11-HY)
Preamplifier	Jet-Power	JAP00101800 -30-10P	160118550 004	1GHz~18GHz	Apr. 16, 2019	Jan. 16, 2020~ Feb. 11, 2020	Apr. 15, 2020	Radiation (03CH11-HY)
SHF-EHF Horn Antenna	SCHWARZBE CK	BBHA 9170	BBHA9170 576	18GHz- 40GHz	May 14, 2019	Jan. 16, 2020~ Feb. 11, 2020	May 13, 2020	Radiation (03CH11-HY)
EMI Test Receiver	Keysight	N9038A (MXE)	MY554201 70	20MHz~8.4GHz	Mar. 08, 2019	Jan. 16, 2020~ Feb. 11, 2020	Mar. 07, 2020	Radiation (03CH11-HY)
Software	Audix	E3 6.2009-8-24	RK-00105 3	N/A	N/A	Jan. 16, 2020~ Feb. 11, 2020	N/A	Radiation (03CH11-HY)
RF Cable	HUBER + SUHNER	SUCOFLEX 104	MY9837/4 PE	9kHz-30MHz	Mar. 13, 2019	Jan. 16, 2020~ Feb. 11, 2020	Mar. 12, 2020	Radiation (03CH11-HY)
RF Cable	HUBER + SUHNER	SUCOFLEX 102	MY2859/2	30MHz-40GHz	Mar. 13, 2019	Jan. 16, 2020~ Feb. 11, 2020	Mar. 12, 2020	Radiation (03CH11-HY)
RF Cable	HUBER + SUHNER	SUCOFLEX 104	MY9837/4 PE	30M-18G	Mar. 13, 2019	Jan. 16, 2020~ Feb. 11, 2020	Mar. 12, 2020	Radiation (03CH11-HY)
RF Cable	HUBER + SUHNER	SUCOFLEX 102	MY4274/2	30MHz-40GHz	Mar. 13, 2019	Jan. 16, 2020~ Feb. 11, 2020	Mar. 12, 2020	Radiation (03CH11-HY)
Filter	Wainwright	WLK4-1000-1 530-8000-40S S	SN11	1.53G Low Pass	Sep. 15, 2019	Jan. 16, 2020~ Feb. 11, 2020	Sep. 14, 2020	Radiation (03CH11-HY)
Filter	Wainwright	WHKX8-5872. 5-6750-18000 -40SS	SN3	6.75GHz High Pass	Sep. 16, 2019	Jan. 16, 2020~ Feb. 11, 2020	Sep. 15, 2020	Radiation (03CH11-HY)
Hygrometer	TECPEL	DTN-303B	TP140325	N/A	Nov. 07, 2019	Jan. 16, 2020~ Feb. 11, 2020	Nov. 06, 2020	Radiation (03CH11-HY)



5 Uncertainty of Evaluation

Uncertainty of Conducted Emission Measurement (150kHz ~ 30MHz)

Measuring Uncertainty for a Level of Confidence of 95% (U = 2Uc(y))	2.00
---	------

<For 03CH11-HY>

Uncertainty of Radiated Emission Measurement (30 MHz ~ 1000 MHz)

Measuring Uncertainty for a Level of Confidence of 95% (U = 2Uc(y))	5.20
---	------

Uncertainty of Radiated Emission Measurement (1000 MHz ~ 18000 MHz)

Measuring Uncertainty for a Level of Confidence of 95% (U = 2Uc(y))	5.20
---	------

Uncertainty of Radiated Emission Measurement (18000 MHz ~ 40000 MHz)

Measuring Uncertainty for a Level of Confidence of 95% (U = 2Uc(y))	3.12
---	------

<For 03CH13-HY>

Uncertainty of Radiated Emission Measurement (30 MHz ~ 1000 MHz)

Measuring Uncertainty for a Level of Confidence of 95% (U = 2Uc(y))	4.40
---	------

Uncertainty of Radiated Emission Measurement (1000 MHz ~ 18000 MHz)

Measuring Uncertainty for a Level of Confidence of 95% (U = 2Uc(y))	5.50
---	------

Uncertainty of Radiated Emission Measurement (18000 MHz ~ 40000 MHz)

Measuring Uncertainty for a Level of Confidence of 95% (U = 2Uc(y))	4.80
---	------

Appendix A. Test Result of Conducted Test Items**<CDD Mode>**

Test Engineer:	Luffy Lin/Richard Qiu/Hank Hsu	Temperature:	21~25	°C
Test Date:	2019/12/26 ~2020/02/12	Relative Humidity:	51~54	%

TEST RESULTS DATA
26dB and 99% OBW

Band I MIMO													
Mod.	Data Rate	NTX	CH.	Freq. (MHz)	99% Bandwidth (MHz)		26 dB Bandwidth (MHz)		IC 99% Bandwidth Power Limit (dBm)		IC 99% Bandwidth EIRP Limit (dBm)		Note
					Ant 1	Ant 2	Ant 1	Ant 2	Ant 1	Ant 2	Ant 1	Ant 2	
11a	6Mbps	2	36	5180	16.38	18.78	21.78	37.41	-	-	22.14		
11a	6Mbps	2	44	5220	16.38	18.03	25.33	36.56	-	-	22.14		
11a	6Mbps	2	48	5240	16.43	19.78	27.42	36.81	-	-	22.16		
VHT20	MCS0	2	36	5180	17.58	18.38	24.08	37.06	-	-	22.45		
VHT20	MCS0	2	44	5220	17.63	18.23	26.07	36.66	-	-	22.46		
VHT20	MCS0	2	48	5240	17.63	18.73	28.07	37.06	-	-	22.46		
VHT40	MCS0	2	38	5190	41.56	66.23	87.60	101.69	-	-	23.01		
VHT40	MCS0	2	46	5230	39.86	67.83	82.69	101.57	-	-	23.01		
VHT80	MCS0	2	42	5210	77.20	98.78	169.19	206.30	-	-	23.01		

TEST RESULTS DATA
Average Power Table

FCC Band I single antenna												
Mod.	Data Rate	NTX	CH.	Freq. (MHz)	Average Conducted Power (dBm)			FCC Conducted Power Limit (dBm)		DG (dBi)		Pass/Fail
					Ant 1	Ant 2	SUM	Ant 1	Ant 2	Ant 1	Ant 2	
11a	6Mbps	1	36	5180	16.80	17.10		24.00	24.00	1.50	1.30	Pass
11a	6Mbps	1	44	5220	17.10	17.10		24.00	24.00	1.50	1.30	Pass
11a	6Mbps	1	48	5240	17.20	17.00		24.00	24.00	1.50	1.30	Pass
HT20	MCS0	1	36	5180	16.70	16.80		24.00	24.00	1.50	1.30	Pass
HT20	MCS0	1	44	5220	16.80	17.00		24.00	24.00	1.50	1.30	Pass
HT20	MCS0	1	48	5240	16.80	16.70		24.00	24.00	1.50	1.30	Pass
HT40	MCS0	1	38	5190	15.60	15.60		24.00	24.00	1.50	1.30	Pass
HT40	MCS0	1	46	5230	16.90	16.80		24.00	24.00	1.50	1.30	Pass
VHT20	MCS0	1	36	5180	17.10	16.90		24.00	24.00	1.50	1.30	Pass
VHT20	MCS0	1	44	5220	16.90	17.10		24.00	24.00	1.50	1.30	Pass
VHT20	MCS0	1	48	5240	16.90	16.80		24.00	24.00	1.50	1.30	Pass
VHT40	MCS0	1	38	5190	15.70	15.70		24.00	24.00	1.50	1.30	Pass
VHT40	MCS0	1	46	5230	17.00	16.90		24.00	24.00	1.50	1.30	Pass
VHT80	MCS0	1	42	5210	14.60	14.90		24.00	24.00	1.50	1.30	Pass

FCC Band I MIMO												
Mod.	Data Rate	NTX	CH.	Freq. (MHz)	Average Conducted Power (dBm)			FCC Conducted Power Limit (dBm)		DG (dBi)		Pass/Fail
					Ant 1	Ant 2	SUM	Ant 1	Ant 2	Ant 1	Ant 2	
11a	6Mbps	2	36	5180	17.20	17.00	20.11	24.00		1.50		Pass
11a	6Mbps	2	44	5220	17.50	16.80	20.17	24.00		1.50		Pass
11a	6Mbps	2	48	5240	17.60	16.80	20.23	24.00		1.50		Pass
HT20	MCS0	2	36	5180	17.20	16.60	19.92	24.00		1.50		Pass
HT20	MCS0	2	44	5220	17.90	16.30	20.18	24.00		1.50		Pass
HT20	MCS0	2	48	5240	17.70	16.00	19.94	24.00		1.50		Pass
HT40	MCS0	2	38	5190	16.30	15.00	18.71	24.00		1.50		Pass
HT40	MCS0	2	46	5230	17.20	16.20	19.74	24.00		1.50		Pass
VHT20	MCS0	2	36	5180	17.70	16.60	20.20	24.00		1.50		Pass
VHT20	MCS0	2	44	5220	18.00	16.30	20.24	24.00		1.50		Pass
VHT20	MCS0	2	48	5240	17.80	16.00	20.00	24.00		1.50		Pass
VHT40	MCS0	2	38	5190	16.40	15.00	18.77	24.00		1.50		Pass
VHT40	MCS0	2	46	5230	17.30	16.20	19.80	24.00		1.50		Pass
VHT80	MCS0	2	42	5210	15.40	14.40	17.94	24.00		1.50		Pass

TEST RESULTS DATA
Power Spectral Density

FCC Band I MIMO												
Mod.	Data Rate	NTX	CH.	Freq. (MHz)	Average Power Density (dBm/MHz)			Average PSD Limit (dBm/MHz)		DG (dBi)		Pass /Fail
					Ant 1	Ant 2	SUM	Ant 1	Ant 2	Ant 1	Ant 2	
11a	6Mbps	2	36	5180			9.76	11.00	4.41		Pass	
11a	6Mbps	2	44	5220			9.75	11.00	4.41		Pass	
11a	6Mbps	2	48	5240			9.82	11.00	4.41		Pass	
VHT20	MCS0	2	36	5180			9.51	11.00	4.41		Pass	
VHT20	MCS0	2	44	5220			9.72	11.00	4.41		Pass	
VHT20	MCS0	2	48	5240			9.33	11.00	4.41		Pass	
VHT40	MCS0	2	38	5190			5.00	11.00	4.41		Pass	
VHT40	MCS0	2	46	5230			6.12	11.00	4.41		Pass	
VHT80	MCS0	2	42	5210			1.39	11.00	4.41		Pass	

TEST RESULTS DATA
26dB and 99% OBW

Band II MIMO															
Mod.	Data Rate	NTX	CH.	Freq. (MHz)	99% Bandwidth (MHz)		26 dB Bandwidth (MHz)		IC 99% Bandwidth Power Limit (dBm)		IC 99% Bandwidth EIRP Limit (dBm)		FCC 26dB Bandwidth Power Limit (dBm)		Note
					Ant 1	Ant 2	Ant 1	Ant 2	Ant 1	Ant 2	Ant 1	Ant 2	Ant 1	Ant 2	
11a	6Mbps	2	52	5260	16.43	20.08	25.72	38.61	23.16		29.16		23.98		
11a	6Mbps	2	60	5300	16.33	21.48	21.68	39.11	23.13		29.13		23.98		
11a	6Mbps	2	64	5320	16.38	20.73	22.33	39.41	23.14		29.14		23.98		
VHT20	MCS0	2	52	5260	17.68	19.33	26.87	38.21	23.48		29.48		23.98		
VHT20	MCS0	2	60	5300	17.63	19.03	23.83	36.96	23.46		29.46		23.98		
VHT20	MCS0	2	64	5320	17.63	18.78	24.63	37.01	23.46		29.46		23.98		
VHT40	MCS0	2	54	5270	42.16	70.53	86.55	103.73	23.98		30.00		23.98		
VHT40	MCS0	2	62	5310	66.73	67.93	100.82	102.39	23.98		30.00		23.98		
VHT80	MCS0	2	58	5290	76.12	98.54	146.57	210.11	23.98		30.00		23.98		

TEST RESULTS DATA
Average Power Table

FCC Band II single antenna													
Mod.	Data Rate	NTX	CH.	Freq. (MHz)	Average Conducted Power (dBm)			FCC Conducted Power Limit (dBm)		DG (dBi)		EIRP Power Limit (dBm)	Pass/Fail
					Ant 1	Ant 2	SUM	Ant 1	Ant 2	Ant 1	Ant 2		
11a	6Mbps	1	52	5260	17.20	17.20		23.98	23.98	1.50	1.30	30	Pass
11a	6Mbps	1	60	5300	17.10	17.20		23.98	23.98	1.50	1.30	30	Pass
11a	6Mbps	1	64	5320	17.10	17.20		23.98	23.98	1.50	1.30	30	Pass
HT20	MCS0	1	52	5260	16.90	16.70		23.98	23.98	1.50	1.30	30	Pass
HT20	MCS0	1	60	5300	16.70	16.90		23.98	23.98	1.50	1.30	30	Pass
HT20	MCS0	1	64	5320	16.80	17.00		23.98	23.98	1.50	1.30	30	Pass
HT40	MCS0	1	54	5270	16.90	17.00		23.98	23.98	1.50	1.30	30	Pass
HT40	MCS0	1	62	5310	16.80	16.80		23.98	23.98	1.50	1.30	30	Pass
VHT20	MCS0	1	52	5260	17.00	16.80		23.98	23.98	1.50	1.30	30	Pass
VHT20	MCS0	1	60	5300	16.80	17.00		23.98	23.98	1.50	1.30	30	Pass
VHT20	MCS0	1	64	5320	16.90	17.10		23.98	23.98	1.50	1.30	30	Pass
VHT40	MCS0	1	54	5270	17.00	17.10		23.98	23.98	1.50	1.30	30	Pass
VHT40	MCS0	1	62	5310	16.90	16.90		23.98	23.98	1.50	1.30	30	Pass
VHT80	MCS0	1	58	5290	15.00	15.30		23.98	23.98	1.50	1.30	30	Pass

FCC Band II MIMO													
Mod.	Data Rate	NTX	CH.	Freq. (MHz)	Average Conducted Power (dBm)			FCC Conducted Power Limit (dBm)		DG (dBi)		EIRP Power Limit (dBm)	Pass/Fail
					Ant 1	Ant 2	SUM	Ant 1	Ant 2	Ant 1	Ant 2		
11a	6Mbps	2	52	5260	17.60	16.90	20.27	23.98		1.50		30	Pass
11a	6Mbps	2	60	5300	17.30	17.20	20.26	23.98		1.50		30	Pass
11a	6Mbps	2	64	5320	17.40	17.10	20.26	23.98		1.50		30	Pass
HT20	MCS0	2	52	5260	17.70	16.10	19.98	23.98		1.50		30	Pass
HT20	MCS0	2	60	5300	17.50	16.40	20.00	23.98		1.50		30	Pass
HT20	MCS0	2	64	5320	17.70	16.40	20.11	23.98		1.50		30	Pass
HT40	MCS0	2	54	5270	17.80	16.30	20.12	23.98		1.50		30	Pass
HT40	MCS0	2	62	5310	17.20	15.90	19.61	23.98		1.50		30	Pass
VHT20	MCS0	2	52	5260	17.80	16.10	20.04	23.98		1.50		30	Pass
VHT20	MCS0	2	60	5300	17.60	16.40	20.05	23.98		1.50		30	Pass
VHT20	MCS0	2	64	5320	17.80	16.40	20.17	23.98		1.50		30	Pass
VHT40	MCS0	2	54	5270	17.90	16.30	20.18	23.98		1.50		30	Pass
VHT40	MCS0	2	62	5310	17.30	15.80	19.62	23.98		1.50		30	Pass
VHT80	MCS0	2	58	5290	15.80	14.90	18.38	23.98		1.50		30	Pass

TEST RESULTS DATA
Power Spectral Density

Band II MIMO												
Mod.	Data Rate	NTX	CH.	Freq. (MHz)	Average Power Density (dBm/MHz)			Average PSD Limit (dBm/MHz)		DG (dBi)		Pass /Fail
					Ant 1	Ant 2	SUM	Ant 1	Ant 2	Ant 1	Ant 2	
11a	6Mbps	2	52	5260			9.87	11.00		4.41	Pass	
11a	6Mbps	2	60	5300			9.81	11.00		4.41	Pass	
11a	6Mbps	2	64	5320			9.79	11.00		4.41	Pass	
VHT20	MCS0	2	52	5260			9.47	11.00		4.41	Pass	
VHT20	MCS0	2	60	5300			9.47	11.00		4.41	Pass	
VHT20	MCS0	2	64	5320			9.55	11.00		4.41	Pass	
VHT40	MCS0	2	54	5270			6.39	11.00		4.41	Pass	
VHT40	MCS0	2	62	5310			4.86	11.00		4.41	Pass	
VHT80	MCS0	2	58	5290			0.85	11.00		4.41	Pass	

TEST RESULTS DATA
26dB and 99% OBW

Band III MIMO																
Mod.	Data Rate	NTX	CH.	Freq. (MHz)	99% Bandwidth In U-NII 2C (MHz)		26 dB Bandwidth In U-NII 2C (MHz)		IC 99% Bandwidth Power Limit (dBm)		IC 99% Bandwidth EIRP Limit (dBm)		FCC 26dB Bandwidth Power Limit (dBm)		6 dB Bandwidth for Straddle Channel (MHz)	
					Ant 1	Ant 2	Ant 1	Ant 2	Ant 1	Ant 2	Ant 1	Ant 2	Ant 1	Ant 2	Ant 1	Ant 2
11a	6Mbps	2	100	5500	16.33	17.08	21.08	35.37	23.13	29.13	23.98	----	----			
11a	6Mbps	2	116	5580	16.38	16.83	21.13	32.17	23.14	29.14	23.98	----	----			
11a	6Mbps	2	140	5700	16.43	18.33	21.68	37.16	23.16	29.16	23.98	----	----			
VHT20	MCS0	2	100	5500	17.53	17.88	22.13	32.37	23.44	29.44	23.98	----	----			
VHT20	MCS0	2	116	5580	17.53	17.73	22.03	28.97	23.44	29.44	23.98	----	----			
VHT20	MCS0	2	140	5700	17.53	18.13	21.83	34.57	23.44	29.44	23.98	----	----			
VHT40	MCS0	2	102	5510	55.15	55.35	94.88	96.19	23.98	30.00	23.98	----	----			
VHT40	MCS0	2	110	5550	36.46	54.85	60.56	94.95	23.98	30.00	23.98	----	----			
VHT40	MCS0	2	134	5670	37.06	62.34	80.89	99.14	23.98	30.00	23.98	----	----			
VHT80	MCS0	2	106	5530	76.36	83.20	134.03	191.25	23.98	30.00	23.98	----	----			
VHT80	MCS0	2	122	5610	75.88	76.60	81.04	103.58	23.98	30.00	23.98	----	----			

TEST RESULTS DATA
Average Power Table

FCC Band III single antenna													
Mod.	Data Rate	NTX	CH.	Freq. (MHz)	Average Conducted Power (dBm)			FCC Conducted Power Limit (dBm)		DG (dBi)		EIRP Power Limit (dBm)	Pass/Fail
					Ant 1	Ant 2	SUM	Ant 1	Ant 2	Ant 1	Ant 2		
11a	6Mbps	1	100	5500	17.00	17.00		23.98	23.98	1.50	1.30	30	Pass
11a	6Mbps	1	116	5580	17.10	17.00		23.98	23.98	1.50	1.30	30	Pass
11a	6Mbps	1	140	5700	15.80	15.80		23.98	23.98	1.50	1.30	30	Pass
HT20	MCS0	1	100	5500	16.80	17.00		23.98	23.98	1.50	1.30	30	Pass
HT20	MCS0	1	116	5580	17.10	16.60		23.98	23.98	1.50	1.30	30	Pass
HT20	MCS0	1	140	5700	17.10	17.10		23.98	23.98	1.50	1.30	30	Pass
HT40	MCS0	1	102	5510	16.70	16.60		23.98	23.98	1.50	1.30	30	Pass
HT40	MCS0	1	110	5550	17.00	16.80		23.98	23.98	1.50	1.30	30	Pass
HT40	MCS0	1	134	5670	16.80	16.90		23.98	23.98	1.50	1.30	30	Pass
VHT20	MCS0	1	100	5500	16.90	17.10		23.98	23.98	1.50	1.30	30	Pass
VHT20	MCS0	1	116	5580	17.20	16.70		23.98	23.98	1.50	1.30	30	Pass
VHT20	MCS0	1	140	5700	17.30	17.20		23.98	23.98	1.50	1.30	30	Pass
VHT40	MCS0	1	102	5510	16.80	16.70		23.98	23.98	1.50	1.30	30	Pass
VHT40	MCS0	1	110	5550	17.00	16.90		23.98	23.98	1.50	1.30	30	Pass
VHT40	MCS0	1	134	5670	16.90	17.00		23.98	23.98	1.50	1.30	30	Pass
VHT80	MCS0	1	106	5530	16.20	16.20		23.98	23.98	1.50	1.30	30	Pass
VHT80	MCS0	1	122	5610	17.00	16.80		23.98	23.98	1.50	1.30	30	Pass

FCC Band III MIMO													
Mod.	Data Rate	NTX	CH.	Freq. (MHz)	Average Conducted Power (dBm)			FCC Conducted Power Limit (dBm)		DG (dBi)		EIRP Power Limit (dBm)	Pass/Fail
					Ant 1	Ant 2	SUM	Ant 1	Ant 2	Ant 1	Ant 2		
11a	6Mbps	2	100	5500	17.50	16.70	20.13	23.98	23.98	1.50	1.30	30	Pass
11a	6Mbps	2	116	5580	17.90	16.50	20.27	23.98	23.98	1.50	1.30	30	Pass
11a	6Mbps	2	140	5700	16.20	15.60	18.92	23.98	23.98	1.50	1.30	30	Pass
HT20	MCS0	2	100	5500	17.80	16.10	20.04	23.98	23.98	1.50	1.30	30	Pass
HT20	MCS0	2	116	5580	18.10	16.00	20.19	23.98	23.98	1.50	1.30	30	Pass
HT20	MCS0	2	140	5700	17.90	16.40	20.22	23.98	23.98	1.50	1.30	30	Pass
HT40	MCS0	2	102	5510	17.70	16.10	19.98	23.98	23.98	1.50	1.30	30	Pass
HT40	MCS0	2	110	5550	17.50	15.80	19.74	23.98	23.98	1.50	1.30	30	Pass
HT40	MCS0	2	134	5670	17.40	16.30	19.90	23.98	23.98	1.50	1.30	30	Pass
VHT20	MCS0	2	100	5500	17.90	16.10	20.10	23.98	23.98	1.50	1.30	30	Pass
VHT20	MCS0	2	116	5580	18.20	16.00	20.25	23.98	23.98	1.50	1.30	30	Pass
VHT20	MCS0	2	140	5700	18.00	16.40	20.28	23.98	23.98	1.50	1.30	30	Pass
VHT40	MCS0	2	102	5510	17.80	16.00	20.00	23.98	23.98	1.50	1.30	30	Pass
VHT40	MCS0	2	110	5550	17.90	15.80	19.99	23.98	23.98	1.50	1.30	30	Pass
VHT40	MCS0	2	134	5670	17.70	16.00	19.94	23.98	23.98	1.50	1.30	30	Pass
VHT80	MCS0	2	106	5530	16.10	16.40	19.26	23.98	23.98	1.50	1.30	30	Pass
VHT80	MCS0	2	122	5610	17.50	16.50	20.04	23.98	23.98	1.50	1.30	30	Pass

TEST RESULTS DATA
Power Spectral Density

Band III MIMO												
Mod.	Data Rate	NTX	CH.	Freq. (MHz)	Average Power Density (dBm/MHz)			Average PSD Limit (dBm/MHz)		DG (dBi)		Pass /Fail
					Ant 1	Ant 2	SUM	Ant 1	Ant 2	Ant 1	Ant 2	
11a	6Mbps	2	100	5500			9.22	11.00	4.41		Pass	
11a	6Mbps	2	116	5580			9.50	11.00	4.41		Pass	
11a	6Mbps	2	140	5700			7.65	11.00	4.41		Pass	
VHT20	MCS0	2	100	5500			9.33	11.00	4.41		Pass	
VHT20	MCS0	2	116	5580			9.54	11.00	4.41		Pass	
VHT20	MCS0	2	140	5700			8.95	11.00	4.41		Pass	
VHT40	MCS0	2	102	5510			5.36	11.00	4.41		Pass	
VHT40	MCS0	2	110	5550			6.40	11.00	4.41		Pass	
VHT40	MCS0	2	134	5670			6.23	11.00	4.41		Pass	
VHT80	MCS0	2	106	5530			2.82	11.00	4.41		Pass	
VHT80	MCS0	2	122	5610			3.30	11.00	4.41		Pass	

TEST RESULTS DATA
26dB and 99% OBW

Band 1 MIMO														
Mod.	Data Rate	N _{TX}	CH.	Freq. (MHz)	RU Config	99% Bandwidth (MHz)		26 dB Bandwidth (MHz)		IC 99% Bandwidth Power Limit (dBm)		IC 99% Bandwidth EIRP Limit (dBm)		Note
						Ant 1	Ant 2	Ant 1	Ant 2	Ant 1	Ant 2	Ant 1	Ant 2	
HE20	MCS0	2	36	5180	Full	18.98	20.23	32.72	43.81	-	-	22.78		
HE20	MCS0	2	44	5220	Full	19.03	20.08	33.72	42.36	-	-	22.79		
HE20	MCS0	2	48	5240	Full	19.03	21.73	33.07	42.16	-	-	22.79		
HE40	MCS0	2	38	5190	Full	43.06	67.63	85.08	102.39	-	-	23.01		
HE40	MCS0	2	46	5230	Full	43.16	70.33	83.92	108.12	-	-	23.01		
HE80	MCS0	2	42	5210	Full	77.20	98.06	175.98	215.31	-	-	23.01		

TEST RESULTS DATA
Average Power Table

FCC Band I single antenna													
Mod.	Data Rate	NTX	CH.	Freq. (MHz)	RU Config	Average Conducted Power (dBm)			FCC Conducted Power Limit (dBm)		DG (dBi)		Pass/Fail
						Ant 1	Ant 2	SUM	Ant 1	Ant 2	Ant 1	Ant 2	
HE20	MCS0	1	36	5180	Full	16.30	16.10		24.00	24.00	1.50	1.30	Pass
HE20	MCS0	1	36	5180	26/0	9.80	10.00		24.00	24.00	1.50	1.30	Pass
HE20	MCS0	1	36	5180	52/37	11.60	11.50		24.00	24.00	1.50	1.30	Pass
HE20	MCS0	1	36	5180	106/53	14.70	14.60		24.00	24.00	1.50	1.30	Pass
HE20	MCS0	1	44	5220	Full	16.90	16.80		24.00	24.00	1.50	1.30	Pass
HE20	MCS0	1	48	5240	Full	17.00	16.70		24.00	24.00	1.50	1.30	Pass
HE40	MCS0	1	38	5190	Full	15.10	15.10		24.00	24.00	1.50	1.30	Pass
HE40	MCS0	1	38	5190	242/61	15.00	15.10		24.00	24.00	1.50	1.30	Pass
HE40	MCS0	1	46	5230	Full	17.20	17.20		24.00	24.00	1.50	1.30	Pass
HE80	MCS0	1	42	5210	Full	14.70	14.80		24.00	24.00	1.50	1.30	Pass
HE80	MCS0	1	42	5210	484/65	14.50	14.30		24.00	24.00	1.50	1.30	Pass

FCC Band I MIMO													
Mod.	Data Rate	NTX	CH.	Freq. (MHz)	RU Config	Average Conducted Power (dBm)			FCC Conducted Power Limit (dBm)		DG (dBi)		Pass/Fail
						Ant 1	Ant 2	SUM	Ant 1	Ant 2	Ant 1	Ant 2	
HE20	MCS0	2	36	5180	Full	16.90	15.90	19.44	24.00	24.00	1.50	1.50	Pass
HE20	MCS0	2	36	5180	26/0	10.60	9.50	13.10	24.00	24.00	1.50	1.50	Pass
HE20	MCS0	2	36	5180	52/37	12.30	11.40	14.88	24.00	24.00	1.50	1.50	Pass
HE20	MCS0	2	36	5180	106/53	15.50	15.80	18.66	24.00	24.00	1.50	1.50	Pass
HE20	MCS0	2	44	5220	Full	17.80	16.00	20.00	24.00	24.00	1.50	1.50	Pass
HE20	MCS0	2	48	5240	Full	17.60	15.90	19.84	24.00	24.00	1.50	1.50	Pass
HE40	MCS0	2	38	5190	Full	15.90	14.30	18.18	24.00	24.00	1.50	1.50	Pass
HE40	MCS0	2	38	5190	242/61	15.90	14.20	18.14	24.00	24.00	1.50	1.50	Pass
HE40	MCS0	2	46	5230	Full	17.50	16.30	19.95	24.00	24.00	1.50	1.50	Pass
HE80	MCS0	2	42	5210	Full	15.30	14.30	17.84	24.00	24.00	1.50	1.50	Pass
HE80	MCS0	2	42	5210	484/65	14.90	14.10	17.53	24.00	24.00	1.50	1.50	Pass

TEST RESULTS DATA
Power Spectral Density

FCC Band I MIMO													
Mod.	Data Rate	NTX	CH.	Freq. (MHz)	RU Config	Average Power Density (dBm/MHz)			Average PSD Limit (dBm/MHz)		DG (dBi)		Pass /Fail
						Ant 1	Ant 2	SUM	Ant 1	Ant 2	Ant 1	Ant 2	
HE20	MCS0	2	36	5180	Full			8.56		11.00		4.41	Pass
HE20	MCS0	2	36	5180	26/0			10.98		11.00		4.41	Pass
HE20	MCS0	2	36	5180	52/37			10.59		11.00		4.41	Pass
HE20	MCS0	2	36	5180	106/53			10.52		11.00		4.41	Pass
HE20	MCS0	2	44	5220	Full			9.05		11.00		4.41	Pass
HE20	MCS0	2	48	5240	Full			9.45		11.00		4.41	Pass
HE40	MCS0	2	38	5190	Full			4.40		11.00		4.41	Pass
HE40	MCS0	2	38	5190	242/61			8.72		11.00		4.41	Pass
HE40	MCS0	2	46	5230	Full			6.73		11.00		4.41	Pass
HE80	MCS0	2	42	5210	Full			1.50		11.00		4.41	Pass
HE80	MCS0	2	42	5210	484/65			3.85		11.00		4.41	Pass

TEST RESULTS DATA
26dB and 99% OBW

Band II MIMO																
Mod.	Data Rate	N _{TX}	CH.	Freq. (MHz)	RU Config	99% Bandwidth (MHz)		26 dB Bandwidth (MHz)		IC 99% Bandwidth Power Limit (dBm)		IC 99% Bandwidth EIRP Limit (dBm)		FCC 26dB Bandwidth Power Limit (dBm)		Note
						Ant 1	Ant 2	Ant 1	Ant 2	Ant 1	Ant 2	Ant 1	Ant 2	Ant 1	Ant 2	
HE20	MCS0	2	52	5260	Full	19.08	21.88	33.37	42.46	23.81		29.81		23.98		
HE20	MCS0	2	60	5300	Full	18.98	23.08	31.57	42.86	23.78		29.78		23.98		
HE20	MCS0	2	64	5320	Full	18.98	19.63	31.07	40.06	23.78		29.78		23.98		
HE40	MCS0	2	54	5270	Full	41.86	73.53	83.79	108.15	23.98		30.00		23.98		
HE40	MCS0	2	62	5310	Full	39.06	71.93	77.70	111.79	23.98		30.00		23.98		
HE80	MCS0	2	58	5290	Full	76.72	104.30	157.44	262.93	23.98		30.00		23.98		

TEST RESULTS DATA
Average Power Table

FCC Band II single antenna														
Mod.	Data Rate	NTX	CH.	Freq. (MHz)	RU Config	Average Conducted Power (dBm)			FCC Conducted Power Limit (dBm)		DG (dBi)		EIRP Power Limit (dBm)	Pass/Fail
						Ant 1	Ant 2	SUM	Ant 1	Ant 2	Ant 1	Ant 2		
HE20	MCS0	1	52	5260	Full	17.00	16.80		23.98	23.98	1.50	1.30	30	Pass
HE20	MCS0	1	60	5300	Full	16.90	16.90		23.98	23.98	1.50	1.30	30	Pass
HE20	MCS0	1	64	5320	Full	16.60	16.50		23.98	23.98	1.50	1.30	30	Pass
HE20	MCS0	1	64	5320	26/8	9.50	9.60		23.98	23.98	1.50	1.30	30	Pass
HE20	MCS0	1	64	5320	52/40	11.80	11.80		23.98	23.98	1.50	1.30	30	Pass
HE20	MCS0	1	64	5320	106/54	14.50	14.50		23.98	23.98	1.50	1.30	30	Pass
HE40	MCS0	1	54	5270	Full	17.00	17.00		23.98	23.98	1.50	1.30	30	Pass
HE40	MCS0	1	54	5270	242/62	16.80	16.80		23.98	23.98	1.50	1.30	30	Pass
HE40	MCS0	1	62	5310	Full	15.20	15.20		23.98	23.98	1.50	1.30	30	Pass
HE40	MCS0	1	62	5310	242/62	16.60	16.60		23.98	23.98	1.50	1.30	30	Pass
HE80	MCS0	1	58	5290	Full	14.60	14.60		23.98	23.98	1.50	1.30	30	Pass
HE80	MCS0	1	58	5290	484/66	14.50	14.60		23.98	23.98	1.50	1.30	30	Pass

FCC Band II MIMO														
Mod.	Data Rate	NTX	CH.	Freq. (MHz)	RU Config	Average Conducted Power (dBm)			FCC Conducted Power Limit (dBm)		DG (dBi)		EIRP Power Limit (dBm)	Pass/Fail
						Ant 1	Ant 2	SUM	Ant 1	Ant 2	Ant 1	Ant 2		
HE20	MCS0	2	52	5260	Full	17.40	16.00	19.77	23.98	23.98	1.50	1.30	30	Pass
HE20	MCS0	2	60	5300	Full	17.40	16.40	19.94	23.98	23.98	1.50	1.30	30	Pass
HE20	MCS0	2	64	5320	Full	17.30	15.90	19.67	23.98	23.98	1.50	1.30	30	Pass
HE20	MCS0	2	64	5320	26/8	10.30	9.30	12.84	23.98	23.98	1.50	1.30	30	Pass
HE20	MCS0	2	64	5320	52/40	12.60	11.50	15.10	23.98	23.98	1.50	1.30	30	Pass
HE20	MCS0	2	64	5320	106/54	15.30	14.30	17.84	23.98	23.98	1.50	1.30	30	Pass
HE40	MCS0	2	54	5270	Full	17.50	16.20	19.91	23.98	23.98	1.50	1.30	30	Pass
HE40	MCS0	2	54	5270	242/62	17.40	16.00	19.77	23.98	23.98	1.50	1.30	30	Pass
HE40	MCS0	2	62	5310	Full	16.10	14.80	18.51	23.98	23.98	1.50	1.30	30	Pass
HE40	MCS0	2	62	5310	242/62	15.90	14.70	18.35	23.98	23.98	1.50	1.30	30	Pass
HE80	MCS0	2	58	5290	Full	14.70	14.60	17.66	23.98	23.98	1.50	1.30	30	Pass
HE80	MCS0	2	58	5290	484/66	14.60	14.50	17.56	23.98	23.98	1.50	1.30	30	Pass

TEST RESULTS DATA
Power Spectral Density

Band II MIMO													
Mod.	Data Rate	NTX	CH.	Freq. (MHz)	Freq. (MHz)	Average Power Density (dBm/MHz)			Average PSD Limit (dBm/MHz)		DG (dBi)		Pass /Fail
						Ant 1	Ant 2	SUM	Ant 1	Ant 2	Ant 1	Ant 2	
HE20	MCS0	2	52	5260	Full			9.21	11.00	4.41		Pass	
HE20	MCS0	2	60	5300	Full			9.26	11.00	4.41		Pass	
HE20	MCS0	2	64	5320	Full			8.15	11.00	4.41		Pass	
HE20	MCS0	2	64	5320	26/8			10.94	11.00	4.41		Pass	
HE20	MCS0	2	64	5320	52/40			10.69	11.00	4.41		Pass	
HE20	MCS0	2	64	5320	106/54			10.83	11.00	4.41		Pass	
HE40	MCS0	2	54	5270	Full			6.25	11.00	4.41		Pass	
HE40	MCS0	2	54	5270	242/62			6.95	11.00	4.41		Pass	
HE40	MCS0	2	62	5310	Full			4.20	11.00	4.41		Pass	
HE40	MCS0	2	62	5310	242/62			8.17	11.00	4.41		Pass	
HE80	MCS0	2	58	5290	Full			0.43	11.00	4.41		Pass	
HE80	MCS0	2	58	5290	484/66			3.61	11.00	4.41		Pass	

TEST RESULTS DATA
26dB and 99% OBW

Band III MIMO																	
Mod.	Data Rate	N _{TX}	CH.	Freq. (MHz)	RU Config	99% Bandwidth In U-NII 2C (MHz)		26 dB Bandwidth In U-NII 2C (MHz)		IC 99% Bandwidth Power Limit (dBm)		IC 99% Bandwidth EIRP Limit (dBm)		FCC 26dB Bandwidth Power Limit (dBm)		6 dB Bandwidth for Straddle Channel (MHz)	
						Ant 1	Ant 2	Ant 1	Ant 2	Ant 1	Ant 2	Ant 1	Ant 2	Ant 1	Ant 2	Ant 1	Ant 2
HE20	MCS0	2	100	5500	Full	18.93	19.13	22.53	35.71	23.77	29.77	23.98	----	----			
HE20	MCS0	2	116	5580	Full	18.93	19.03	25.08	33.48	23.77	29.77	23.98	----	----			
HE20	MCS0	2	140	5700	Full	18.93	19.13	22.98	35.42	23.77	29.77	23.98	----	----			
HE40	MCS0	2	102	5510	Full	38.36	59.64	67.86	95.39	23.98	30.00	23.98	----	----			
HE40	MCS0	2	110	5550	Full	38.26	58.94	67.28	97.85	23.98	30.00	23.98	----	----			
HE40	MCS0	2	134	5670	Full	38.56	62.74	72.27	103.10	23.98	30.00	23.98	----	----			
HE80	MCS0	2	106	5530	Full	76.48	91.83	152.81	200.44	23.98	30.00	23.98	----	----			
HE80	MCS0	2	122	5610	Full	77.80	80.08	82.16	170.71	23.98	30.00	23.98	----	----			

TEST RESULTS DATA
Average Power Table

FCC Band III single antenna														
Mod.	Data Rate	NTX	CH.	Freq. (MHz)	RU Config	Average Conducted Power (dBm)			FCC Conducted Power Limit (dBm)		DG (dBi)		EIRP Power Limit (dBm)	Pass/Fail
						Ant 1	Ant 2	SUM	Ant 1	Ant 2	Ant 1	Ant 2		
HE20	MCS0	1	100	5500	Full	16.90	17.00		23.98	23.98	1.50	1.30	30	Pass
HE20	MCS0	1	100	5500	26/0	9.60	9.40		23.98	23.98	1.50	1.30	30	Pass
HE20	MCS0	1	100	5500	52/37	11.80	11.80		23.98	23.98	1.50	1.30	30	Pass
HE20	MCS0	1	100	5500	106/53	15.00	14.80		23.98	23.98	1.50	1.30	30	Pass
HE20	MCS0	1	116	5580	Full	16.90	16.70		23.98	23.98	1.50	1.30	30	Pass
HE20	MCS0	1	140	5700	Full	16.20	16.20		23.98	23.98	1.50	1.30	30	Pass
HE20	MCS0	1	140	5700	26/8	9.70	8.90		23.98	23.98	1.50	1.30	30	Pass
HE20	MCS0	1	140	5700	52/40	12.30	12.20		23.98	23.98	1.50	1.30	30	Pass
HE20	MCS0	1	140	5700	106/54	14.70	14.70		23.98	23.98	1.50	1.30	30	Pass
HE40	MCS0	1	102	5510	Full	16.20	16.10		23.98	23.98	1.50	1.30	30	Pass
HE40	MCS0	1	102	5510	242/61	16.90	17.00		23.98	23.98	1.50	1.30	30	Pass
HE40	MCS0	1	110	5550	Full	17.00	16.90		23.98	23.98	1.50	1.30	30	Pass
HE40	MCS0	1	134	5670	Full	16.80	16.80		23.98	23.98	1.50	1.30	30	Pass
HE40	MCS0	1	134	5670	242/62	16.90	16.80		23.98	23.98	1.50	1.30	30	Pass
HE80	MCS0	1	106	5530	Full	16.50	16.40		23.98	23.98	1.50	1.30	30	Pass
HE80	MCS0	1	106	5530	484/65	16.00	16.00		23.98	23.98	1.50	1.30	30	Pass
HE80	MCS0	1	122	5610	Full	16.90	17.00		23.98	23.98	1.50	1.30	30	Pass
HE80	MCS0	1	122	5610	484/66	16.90	16.90		23.98	23.98	1.50	1.30	30	Pass

FCC Band III MIMO														
Mod.	Data Rate	NTX	CH.	Freq. (MHz)	RU Config	Average Conducted Power (dBm)			FCC Conducted Power Limit (dBm)		DG (dBi)		EIRP Power Limit (dBm)	Pass/Fail
						Ant 1	Ant 2	SUM	Ant 1	Ant 2	Ant 1	Ant 2		
HE20	MCS0	2	100	5500	Full	17.90	16.10	20.10	23.98	23.98	1.50	1.30	30	Pass
HE20	MCS0	2	100	5500	26/0	10.60	8.90	12.84	23.98	23.98	1.50	1.30	30	Pass
HE20	MCS0	2	100	5500	52/37	12.90	11.30	15.18	23.98	23.98	1.50	1.30	30	Pass
HE20	MCS0	2	100	5500	106/53	15.90	14.30	18.18	23.98	23.98	1.50	1.30	30	Pass
HE20	MCS0	2	116	5580	Full	18.20	15.90	20.21	23.98	23.98	1.50	1.30	30	Pass
HE20	MCS0	2	140	5700	Full	17.20	15.60	19.48	23.98	23.98	1.50	1.30	30	Pass
HE20	MCS0	2	140	5700	26/8	10.40	9.40	12.94	23.98	23.98	1.50	1.30	30	Pass
HE20	MCS0	2	140	5700	52/40	13.00	11.60	15.37	23.98	23.98	1.50	1.30	30	Pass
HE20	MCS0	2	140	5700	106/54	15.60	13.80	17.80	23.98	23.98	1.50	1.30	30	Pass
HE40	MCS0	2	102	5510	Full	17.20	15.50	19.44	23.98	23.98	1.50	1.30	30	Pass
HE40	MCS0	2	102	5510	242/61	17.90	16.00	20.06	23.98	23.98	1.50	1.30	30	Pass
HE40	MCS0	2	110	5550	Full	18.00	15.80	20.05	23.98	23.98	1.50	1.30	30	Pass
HE40	MCS0	2	134	5670	Full	17.60	16.30	20.01	23.98	23.98	1.50	1.30	30	Pass
HE40	MCS0	2	134	5670	242/62	17.60	16.30	20.01	23.98	23.98	1.50	1.30	30	Pass
HE80	MCS0	2	106	5530	Full	16.40	16.00	19.21	23.98	23.98	1.50	1.30	30	Pass
HE80	MCS0	2	106	5530	484/65	16.60	15.50	19.10	23.98	23.98	1.50	1.30	30	Pass
HE80	MCS0	2	122	5610	Full	17.40	16.40	19.94	23.98	23.98	1.50	1.30	30	Pass
HE80	MCS0	2	122	5610	484/66	17.30	16.30	19.84	23.98	23.98	1.50	1.30	30	Pass

TEST RESULTS DATA
Power Spectral Density

Band III MIMO													
Mod.	Data Rate	NTX	CH.	Freq. (MHz)	RU Config	Average Power Density (dBm/MHz)			Average PSD Limit (dBm/MHz)		DG (dBi)		Pass /Fail
						Ant 1	Ant 2	SUM	Ant 1	Ant 2	Ant 1	Ant 2	
HE20	MCS0	2	100	5500	Full			9.38		11.00		4.41	Pass
HE20	MCS0	2	100	5500	26/0			10.95		11.00		4.41	Pass
HE20	MCS0	2	100	5500	52/37			10.84		11.00		4.41	Pass
HE20	MCS0	2	100	5500	106/53			10.81		11.00		4.41	Pass
HE20	MCS0	2	116	5580	Full			9.66		11.00		4.41	Pass
HE20	MCS0	2	140	5700	Full			8.08		11.00		4.41	Pass
HE20	MCS0	2	140	5700	26/8			10.69		11.00		4.41	Pass
HE20	MCS0	2	140	5700	52/40			10.80		11.00		4.41	Pass
HE20	MCS0	2	140	5700	106/54			10.56		11.00		4.41	Pass
HE40	MCS0	2	102	5510	Full			4.89		11.00		4.41	Pass
HE40	MCS0	2	102	5510	242/61			8.27		11.00		4.41	Pass
HE40	MCS0	2	110	5550	Full			6.51		11.00		4.41	Pass
HE40	MCS0	2	134	5670	Full			6.02		11.00		4.41	Pass
HE40	MCS0	2	134	5670	242/62			8.96		11.00		4.41	Pass
HE80	MCS0	2	106	5530	Full			2.61		11.00		4.41	Pass
HE80	MCS0	2	106	5530	484/65			4.52		11.00		4.41	Pass
HE80	MCS0	2	122	5610	Full			5.72		11.00		4.41	Pass
HE80	MCS0	2	122	5610	484/66			6.82		11.00		4.41	Pass

<TXBF Mode>

Test Engineer:	Richard Qiu	Temperature:	21~25	°C
Test Date:	2020/1/30~2020/2/10	Relative Humidity:	51~54	%

TEST RESULTS DATA
26dB and 99% OBW

Band I MIMO													
Mod.	Data Rate	NTX	CH.	Freq. (MHz)	99% Bandwidth (MHz)		26 dB Bandwidth (MHz)		IC 99% Bandwidth Power Limit (dBm)		IC 99% Bandwidth EIRP Limit (dBm)		Note
					Ant 1	Ant 2	Ant 1	Ant 2	Ant 1	Ant 2	Ant 1	Ant 2	
VHT20	MCS0	2	36	5180	17.88	17.88	25.18	25.28	-	-	22.52	22.52	
VHT20	MCS0	2	44	5220	17.78	17.68	25.38	26.27	-	-	22.48	22.48	
VHT20	MCS0	2	48	5240	17.73	17.88	24.33	26.82	-	-	22.49	22.49	
VHT40	MCS0	2	38	5190	36.66	36.96	43.43	44.33	-	-	23.01	23.01	
VHT40	MCS0	2	46	5230	36.66	36.66	42.62	43.70	-	-	23.01	23.01	
VHT80	MCS0	2	42	5210	77.80	76.96	81.52	81.68	-	-	23.01	23.01	

TEST RESULTS DATA
Average Power Table

FCC Band I MIMO												
Mod.	Data Rate	NTX	CH.	Freq. (MHz)	Average Conducted Power (dBm)			FCC Conducted Power Limit (dBm)		DG (dBi)		Pass/Fail
					Ant 1	Ant 2	SUM	Ant 1	Ant 2	Ant 1	Ant 2	
VHT20	MCS0	2	36	5180	16.00	15.90	18.96	24.00		4.41		Pass
VHT20	MCS0	2	44	5220	16.20	15.80	19.01	24.00		4.41		Pass
VHT20	MCS0	2	48	5240	16.40	15.80	19.12	24.00		4.41		Pass
VHT40	MCS0	2	38	5190	16.20	15.80	19.01	24.00		4.41		Pass
VHT40	MCS0	2	46	5230	16.50	15.80	19.17	24.00		4.41		Pass
VHT80	MCS0	2	42	5210	16.60	15.90	19.27	24.00		4.41		Pass

TEST RESULTS DATA
Power Spectral Density

FCC Band I MIMO												
Mod.	Data Rate	NTX	CH.	Freq. (MHz)	Average Power Density (dBm/MHz)			Average PSD Limit (dBm/MHz)		DG (dBi)		Pass /Fail
					Ant 1	Ant 2	SUM	Ant 1	Ant 2	Ant 1	Ant 2	
VHT20	MCS0	2	36	5180			8.17	11.00	4.41		Pass	
VHT20	MCS0	2	44	5220			9.28	11.00	4.41		Pass	
VHT20	MCS0	2	48	5240			7.96	11.00	4.41		Pass	
VHT40	MCS0	2	38	5190			7.62	11.00	4.41		Pass	
VHT40	MCS0	2	46	5230			7.90	11.00	4.41		Pass	
VHT80	MCS0	2	42	5210			7.94	11.00	4.41		Pass	

TEST RESULTS DATA
26dB and 99% OBW

Band I MIMO														
Mod.	Data Rate	N _{TX}	CH.	Freq. (MHz)	RU Config	99% Bandwidth (MHz)		26 dB Bandwidth (MHz)		IC 99% Bandwidth Power Limit (dBm)		IC 99% Bandwidth EIRP Limit (dBm)		Note
						Ant 1	Ant 2	Ant 1	Ant 2	Ant 1	Ant 2	Ant 1	Ant 2	
HE20	MCS0	2	36	5180	Full	17.48	17.78	22.23	24.43	-	-	22.43		
HE20	MCS0	2	44	5220	Full	17.78	17.78	24.28	24.48	-	-	22.50		
HE20	MCS0	2	48	5240	Full	17.83	17.73	25.97	24.58	-	-	22.49		
HE40	MCS0	2	38	5190	Full	36.86	36.76	43.25	48.01	-	-	23.01		
HE40	MCS0	2	46	5230	Full	36.96	36.66	42.35	40.73	-	-	23.01		
HE80	MCS0	2	42	5210	Full	77.56	82.00	81.84	82.96	-	-	23.01		

TEST RESULTS DATA
Average Power Table

FCC Band I MIMO													
Mod.	Data Rate	NTX	CH.	Freq. (MHz)	RU Config	Average Conducted Power (dBm)			FCC Conducted Power Limit (dBm)		DG (dBi)		Pass/Fail
						Ant 1	Ant 2	SUM	Ant 1	Ant 2	Ant 1	Ant 2	
HE20	MCS0	2	36	5180	Full	16.00	15.90	18.96	24.00	24.00	4.41	4.41	Pass
HE20	MCS0	2	44	5220	Full	16.30	15.60	18.97	24.00	24.00	4.41	4.41	Pass
HE20	MCS0	2	48	5240	Full	16.40	15.80	19.12	24.00	24.00	4.41	4.41	Pass
HE40	MCS0	2	38	5190	Full	16.50	15.80	19.17	24.00	24.00	4.41	4.41	Pass
HE40	MCS0	2	46	5230	Full	16.40	15.80	19.12	24.00	24.00	4.41	4.41	Pass
HE80	MCS0	2	42	5210	Full	16.50	15.40	19.00	24.00	24.00	4.41	4.41	Pass

TEST RESULTS DATA
Power Spectral Density

FCC Band I MIMO													
Mod.	Data Rate	NTX	CH.	Freq. (MHz)	RU Config	Average Power Density (dBm/MHz)			Average PSD Limit (dBm/MHz)		DG (dBi)		Pass /Fail
						Ant 1	Ant 2	SUM	Ant 1	Ant 2	Ant 1	Ant 2	
HE20	MCS0	2	36	5180	Full			7.78	11.00	4.41		Pass	
HE20	MCS0	2	44	5220	Full			8.06	11.00	4.41		Pass	
HE20	MCS0	2	48	5240	Full			8.02	11.00	4.41		Pass	
HE40	MCS0	2	38	5190	Full			7.58	11.00	4.41		Pass	
HE40	MCS0	2	46	5230	Full			7.87	11.00	4.41		Pass	
HE80	MCS0	2	42	5210	Full			7.71	11.00	4.41		Pass	



Appendix B. AC Conducted Emission Test Results

Test Engineer : Tom Lee	Temperature : 21~24°C
	Relative Humidity : 42~45%

EUT Information

Report NO : 9D0635
 Test Mode : Mode 1
 Test Voltage : 120Vac/60Hz
 Phase : Line

Full Spectrum

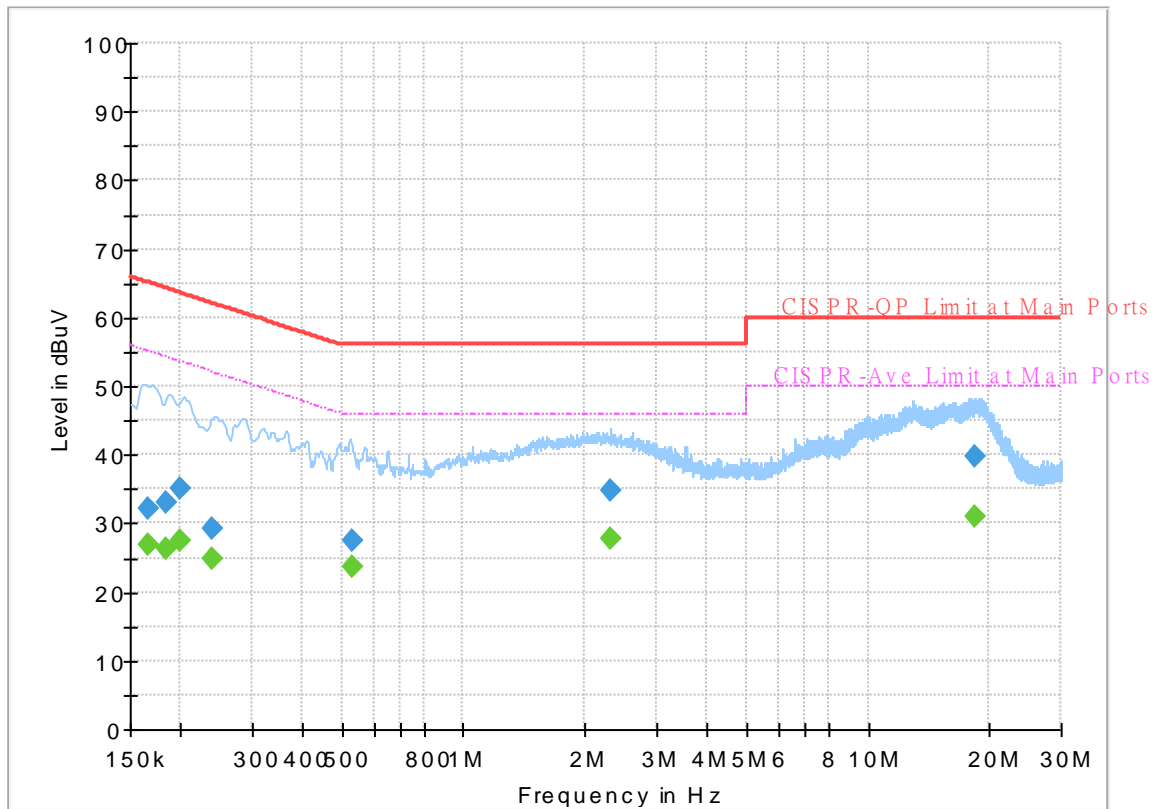

Final Result

Frequency (MHz)	QuasiPeak (dBuV)	CAverage (dBuV)	Limit (dBuV)	Margin (dB)	Line	Filter	Corr. (dB)
0.166110	---	27.02	55.15	28.13	L1	OFF	19.5
0.166110	32.07	---	65.15	33.08	L1	OFF	19.5
0.183750	---	26.19	54.31	28.12	L1	OFF	19.5
0.183750	32.93	---	64.31	31.38	L1	OFF	19.5
0.199500	---	27.38	53.63	26.25	L1	OFF	19.5
0.199500	35.10	---	63.63	28.53	L1	OFF	19.5
0.240000	---	24.73	52.10	27.37	L1	OFF	19.5
0.240000	29.21	---	62.10	32.89	L1	OFF	19.5
0.529440	---	23.58	46.00	22.42	L1	OFF	19.5
0.529440	27.54	---	56.00	28.46	L1	OFF	19.5
2.299650	---	27.89	46.00	18.11	L1	OFF	19.7
2.299650	34.91	---	56.00	21.09	L1	OFF	19.7
18.298500	---	30.87	50.00	19.13	L1	OFF	20.2
18.298500	39.85	---	60.00	20.15	L1	OFF	20.2

EUT Information

Report NO : 9D0635
 Test Mode : Mode 1
 Test Voltage : 120Vac/60Hz
 Phase : Neutral

Full Spectrum

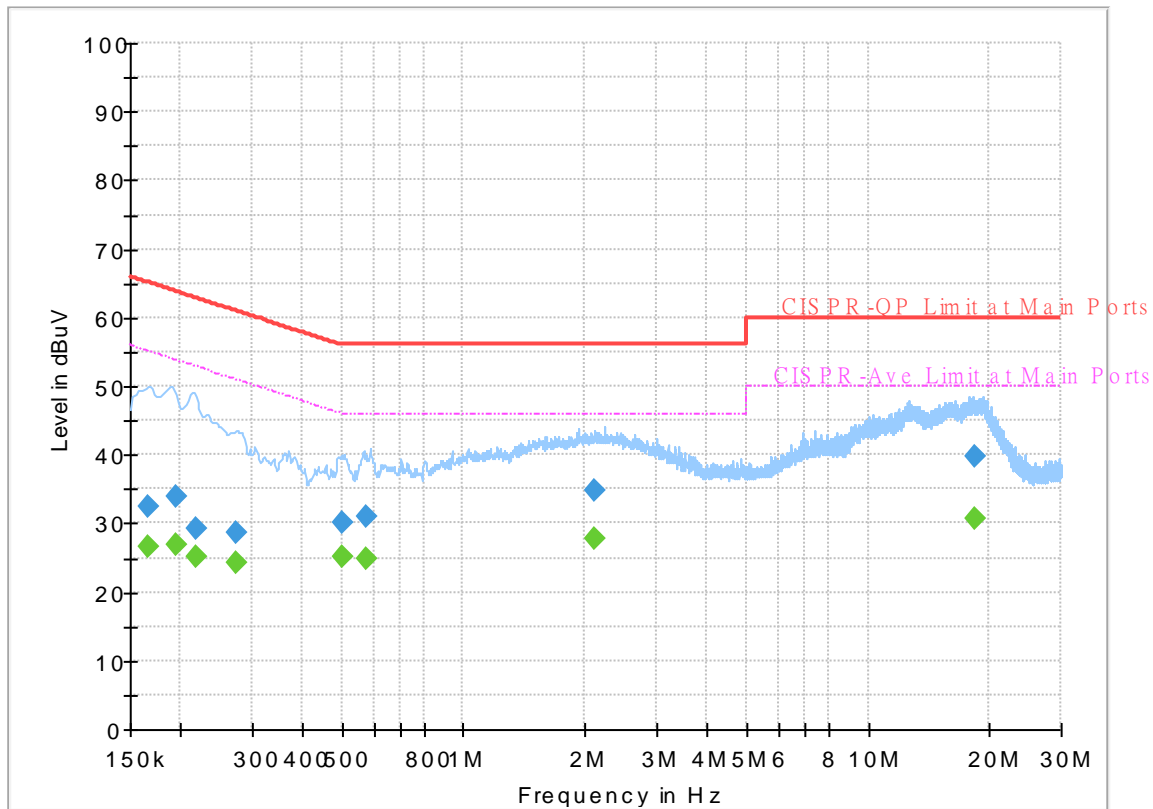

Final_Result

Frequency (MHz)	QuasiPeak (dBuV)	CAverage (dBuV)	Limit (dBuV)	Margin (dB)	Line	Filter	Corr. (dB)
0.165660	---	26.54	55.18	28.64	N	OFF	19.6
0.165660	32.44	---	65.18	32.74	N	OFF	19.6
0.195000	---	26.84	53.82	26.98	N	OFF	19.6
0.195000	33.89	---	63.82	29.93	N	OFF	19.6
0.217230	---	25.21	52.92	27.71	N	OFF	19.6
0.217230	29.10	---	62.92	33.82	N	OFF	19.6
0.274380	---	24.23	50.98	26.75	N	OFF	19.6
0.274380	28.55	---	60.98	32.43	N	OFF	19.6
0.499470	---	25.21	46.01	20.80	N	OFF	19.6
0.499470	30.12	---	56.01	25.89	N	OFF	19.6
0.573000	---	24.96	46.00	21.04	N	OFF	19.6
0.573000	30.85	---	56.00	25.15	N	OFF	19.6
2.112360	---	27.73	46.00	18.27	N	OFF	19.6
2.112360	34.76	---	56.00	21.24	N	OFF	19.6
18.276360	---	30.81	50.00	19.19	N	OFF	20.3
18.276360	39.73	---	60.00	20.27	N	OFF	20.3



Appendix C. Radiated Spurious Emission

Test Engineer :	Jimmy Chung · Karl Hou · Wilson Wu	Temperature :	21.5~23.5°C
		Relative Humidity :	49.5~55.5%

<CDD Mode>

Band 1 - 5150~5250MHz
WIFI 802.11a (Band Edge @ 3m)

WIFI Ant.	Note	Frequency (MHz)	Level (dBμV/m)	Over Limit (dB)	Limit Line (dBμV/m)	Read Level (dBμV)	Antenna Factor (dB/m)	Path Loss (dB)	Preamp Factor (dB)	Ant Pos (cm)	Table Pos (deg)	Peak Avg. (P/A)	Pol. (H/V)	
802.11a CH 36 5180MHz		5147.42	60.14	-13.86	74	48.76	32	6.08	26.7	100	246	P	H	
		5150	50.49	-3.51	54	39.11	32	6.08	26.7	100	246	A	H	
	*	5180	107.35	-	-	96.13	31.82	6.1	26.7	100	246	P	H	
	*	5180	99.59	-	-	88.37	31.82	6.1	26.7	100	246	A	H	
													H	
			5149.5	59.72	-14.28	74	48.34	32	6.08	26.7	100	77	P	V
			5150	49.07	-4.93	54	37.69	32	6.08	26.7	100	77	A	V
	*		5180	105.77	-	-	94.55	31.82	6.1	26.7	100	77	P	V
	*		5180	98.35	-	-	87.13	31.82	6.1	26.7	100	77	A	V
														V
802.11a CH 44 5220MHz		5134.68	61.13	-12.87	74	49.76	32	6.07	26.7	193	305	P	H	
		5149.76	49.55	-4.45	54	38.17	32	6.08	26.7	193	305	A	H	
	*	5220	111.33	-	-	100.34	31.58	6.11	26.7	193	305	P	H	
	*	5220	103.77	-	-	92.78	31.58	6.11	26.7	193	305	A	H	
			5435.92	51.69	-22.31	74	40.48	31.74	6.16	26.69	193	305	P	H
			5459.44	41.08	-12.92	54	29.77	31.82	6.18	26.69	193	305	A	H
			5134.68	62.41	-11.59	74	51.04	32	6.07	26.7	357	3	P	V
			5149.24	49.1	-4.9	54	37.72	32	6.08	26.7	357	3	A	V
	*		5220	111.11	-	-	100.12	31.58	6.11	26.7	357	3	P	V
	*		5220	103.3	-	-	92.31	31.58	6.11	26.7	357	3	A	V
			5416.32	50.9	-23.1	74	39.78	31.67	6.14	26.69	357	3	P	V
			5458.6	41.04	-12.96	54	29.73	31.82	6.18	26.69	357	3	A	V



802.11a CH 48 5240MHz		5149.76	55.55	-18.45	74	44.17	32	6.08	26.7	188	306	P	H
		5150	44.75	-9.25	54	33.37	32	6.08	26.7	188	306	A	H
	*	5240	111.46	-	-	100.59	31.46	6.11	26.7	188	306	P	H
	*	5240	103.88	-	-	93.01	31.46	6.11	26.7	188	306	A	H
		5435.08	51.76	-22.24	74	40.55	31.74	6.16	26.69	188	306	P	H
		5350.52	41.58	-12.42	54	30.76	31.4	6.12	26.7	188	306	A	H
		5144.82	57.37	-16.63	74	45.99	32	6.08	26.7	354	2	P	V
		5150	45.21	-8.79	54	33.83	32	6.08	26.7	354	2	A	V
	*	5240	111.38	-	-	100.51	31.46	6.11	26.7	354	2	P	V
	*	5240	103.49	-	-	92.62	31.46	6.11	26.7	354	2	A	V
		5351.36	50.41	-23.59	74	39.58	31.41	6.12	26.7	354	2	P	V
		5350	41.63	-12.37	54	30.81	31.4	6.12	26.7	354	2	A	V
Remark	<ol style="list-style-type: none"> 1. No other spurious found. 2. All results are PASS against Peak and Average limit line. 												



Band 1 5150~5250MHz
WIFI 802.11a (Harmonic @ 3m)

WIFI Ant. 1+2	Note	Frequency (MHz)	Level (dBμV/m)	Over Limit (dB)	Limit Line (dBμV/m)	Read Level (dBμV)	Antenna Factor (dB/m)	Path Loss (dB)	Preamp Factor (dB)	Ant Pos (cm)	Table Pos (deg)	Peak Avg. (P/A)	Pol. (H/V)
802.11a CH 36 5180MHz		10360	45.98	-22.22	68.2	53.29	39.74	9.91	56.96	100	0	P	H
		15540	46.41	-27.59	74	51.65	38.76	12.65	56.65	100	0	P	H
													H
													H
		10360	46.2	-22	68.2	53.51	39.74	9.91	56.96	100	0	P	V
		15540	45.84	-28.16	74	51.08	38.76	12.65	56.65	100	0	P	V
													V
													V
802.11a CH 44 5220MHz		10440	46.5	-21.7	68.2	53.53	39.94	9.95	56.92	100	0	P	H
		15660	48.32	-25.68	74	53.89	38.22	12.72	56.51	100	0	P	H
													H
													H
		10440	47.31	-20.89	68.2	54.34	39.94	9.95	56.92	100	0	P	V
		15660	45.31	-28.69	74	50.88	38.22	12.72	56.51	100	0	P	V
													V
													V
802.11a CH 48 5240MHz		10480	46.81	-21.39	68.2	53.77	39.98	9.97	56.91	100	0	P	H
		15720	45.7	-28.3	74	51.3	38.1	12.74	56.44	100	0	P	H
													H
													H
		10480	46.79	-21.41	68.2	53.75	39.98	9.97	56.91	100	0	P	V
		15720	44.94	-29.06	74	50.54	38.1	12.74	56.44	100	0	P	V
													V
													V
Remark	1. No other spurious found. 2. All results are PASS against Peak and Average limit line.												



Band 1 5150~5250MHz
WIFI 802.11ac VHT20 (Band Edge @ 3m)

WIFI Ant. 1+2	Note	Frequency (MHz)	Level (dBμV/m)	Over Limit (dB)	Limit Line (dBμV/m)	Read Level (dBμV)	Antenna Factor (dB/m)	Path Loss (dB)	Preamp Factor (dB)	Ant Pos (cm)	Table Pos (deg)	Peak Avg. (P/A)	Pol. (H/V)	
802.11ac VHT20 CH 36 5180MHz		5150	58.29	-15.71	74	46.91	32	6.08	26.7	100	232	P	H	
		5150	50.1	-3.9	54	38.72	32	6.08	26.7	100	232	A	H	
	*	5180	106.22	-	-	95	31.82	6.1	26.7	100	232	P	H	
	*	5180	97.63	-	-	86.41	31.82	6.1	26.7	100	232	A	H	
													H	
														H
			5148.46	58.55	-15.45	74	47.17	32	6.08	26.7	100	211	P	V
			5150	49.19	-4.81	54	37.81	32	6.08	26.7	100	211	A	V
		*	5180	105.55	-	-	94.33	31.82	6.1	26.7	100	211	P	V
		*	5180	97.62	-	-	86.4	31.82	6.1	26.7	100	211	A	V
													V	
													V	
802.11ac VHT20 CH 44 5220MHz		5146.64	60.66	-13.34	74	49.28	32	6.08	26.7	100	230	P	H	
		5149.5	50.22	-3.78	54	38.84	32	6.08	26.7	100	230	A	H	
		* 5220	109.37	-	-	98.38	31.58	6.11	26.7	100	230	P	H	
		* 5220	100.7	-	-	89.71	31.58	6.11	26.7	100	230	A	H	
			5439.28	50.6	-23.4	74	39.37	31.76	6.16	26.69	100	230	P	H
			5460	41.26	-12.74	54	29.95	31.82	6.18	26.69	100	230	A	H
			5143.52	60.73	-13.27	74	49.35	32	6.08	26.7	329	149	P	V
			5150	50.69	-3.31	54	39.31	32	6.08	26.7	329	149	A	V
		*	5220	108.85	-	-	97.86	31.58	6.11	26.7	329	149	P	V
		*	5220	100.78	-	-	89.79	31.58	6.11	26.7	329	149	A	V
		5353.04	51.39	-22.61	74	40.56	31.41	6.12	26.7	329	149	P	V	
		5458.88	41.24	-12.76	54	29.93	31.82	6.18	26.69	329	149	A	V	



802.11ac VHT20 CH 48 5240MHz		5143.52	58.49	-15.51	74	47.11	32	6.08	26.7	163	38	P	H
		5150	46.26	-7.74	54	34.88	32	6.08	26.7	163	38	A	H
	*	5240	110.12	-	-	99.25	31.46	6.11	26.7	163	38	P	H
	*	5240	101.71	-	-	90.84	31.46	6.11	26.7	163	38	A	H
		5362.84	51.11	-22.89	74	40.24	31.45	6.12	26.7	163	38	P	H
		5350	41.74	-12.26	54	30.92	31.4	6.12	26.7	163	38	A	H
		5150	58.12	-15.88	74	46.74	32	6.08	26.7	272	329	P	V
		5150	47.06	-6.94	54	35.68	32	6.08	26.7	272	329	A	V
	*	5240	109.78	-	-	98.91	31.46	6.11	26.7	272	329	P	V
	*	5240	101.59	-	-	90.72	31.46	6.11	26.7	272	329	A	V
		5354.16	50.86	-23.14	74	40.02	31.42	6.12	26.7	272	329	P	V
		5350	41.8	-12.2	54	30.98	31.4	6.12	26.7	272	329	A	V
Remark	1. No other spurious found. 2. All results are PASS against Peak and Average limit line.												



Band 1 5150~5250MHz
WIFI 802.11ac VHT20 (Harmonic @ 3m)

WIFI Ant. 1+2	Note	Frequency (MHz)	Level (dBμV/m)	Over Limit (dB)	Limit Line (dBμV/m)	Read Level (dBμV)	Antenna Factor (dB/m)	Path Loss (dB)	Preamp Factor (dB)	Ant Pos (cm)	Table Pos (deg)	Peak Avg. (P/A)	Pol. (H/V)	
802.11ac VHT20 CH 36 5180MHz		10360	47.33	-20.87	68.2	54.64	39.74	9.91	56.96	100	0	P	H	
		15540	46.01	-27.99	74	51.25	38.76	12.65	56.65	100	0	P	H	
													H	
													H	
			10360	47.29	-20.91	68.2	54.6	39.74	9.91	56.96	100	0	P	V
			15540	45.92	-28.08	74	51.16	38.76	12.65	56.65	100	0	P	V
														V
802.11ac VHT20 CH 44 5220MHz		10440	48	-20.2	68.2	55.03	39.94	9.95	56.92	100	0	P	H	
		15660	45.79	-28.21	74	51.36	38.22	12.72	56.51	100	0	P	H	
													H	
													H	
			10440	47.56	-20.64	68.2	54.59	39.94	9.95	56.92	100	0	P	V
			15660	44.81	-29.19	74	50.38	38.22	12.72	56.51	100	0	P	V
														V
802.11ac VHT20 CH 48 5240MHz		10480	48.37	-19.83	68.2	55.33	39.98	9.97	56.91	100	0	P	H	
		15720	47.13	-26.87	74	52.73	38.1	12.74	56.44	100	0	P	H	
													H	
													H	
			10480	47.55	-20.65	68.2	54.51	39.98	9.97	56.91	100	0	P	V
			15720	46	-28	74	51.6	38.1	12.74	56.44	100	0	P	V
														V
Remark	1. No other spurious found.													
	2. All results are PASS against Peak and Average limit line.													



Band 1 5150~5250MHz
WIFI 802.11ac VHT40 (Band Edge @ 3m)

WIFI Ant. 1+2	Note	Frequency (MHz)	Level (dBμV/m)	Over Limit (dB)	Limit Line (dBμV/m)	Read Level (dBμV)	Antenna Factor (dB/m)	Path Loss (dB)	Preamp Factor (dB)	Ant Pos (cm)	Table Pos (deg)	Peak Avg. (P/A)	Pol. (H/V)
802.11ac VHT40 CH 38 5190MHz		5149.24	59.67	-14.33	74	48.29	32	6.08	26.7	100	212	P	V
		5150	49.2	-4.8	54	37.82	32	6.08	26.7	100	212	A	V
	*	5190	101.19	-	-	90.03	31.76	6.1	26.7	100	212	P	V
	*	5190	93.4	-	-	82.24	31.76	6.1	26.7	100	212	A	V
		5450.48	50.29	-23.71	74	39.01	31.8	6.17	26.69	100	212	P	V
		5457.76	41.27	-12.73	54	29.96	31.82	6.18	26.69	100	212	A	V
		5150	60.02	-13.98	74	48.64	32	6.08	26.7	100	230	P	H
		5149.5	50.27	-3.73	54	38.89	32	6.08	26.7	100	230	A	H
	*	5190	100.9	-	-	89.74	31.76	6.1	26.7	100	230	P	H
	*	5190	93.13	-	-	81.97	31.76	6.1	26.7	100	230	A	H
		5405.12	50.88	-23.12	74	39.82	31.62	6.13	26.69	100	230	P	H
		5458.6	41.26	-12.74	54	29.95	31.82	6.18	26.69	100	230	A	H
802.11ac VHT40 CH 46 5230MHz		5147.68	60.34	-13.66	74	48.96	32	6.08	26.7	100	230	P	H
		5150	49.06	-4.94	54	37.68	32	6.08	26.7	100	230	A	H
	*	5230	103.84	-	-	92.91	31.52	6.11	26.7	100	230	P	H
	*	5230	96.04	-	-	85.11	31.52	6.11	26.7	100	230	A	H
		5399.24	50.15	-23.85	74	39.12	31.6	6.12	26.69	100	230	P	H
		5459.16	41.23	-12.77	54	29.92	31.82	6.18	26.69	100	230	A	H
		5146.64	55.64	-18.36	74	44.26	32	6.08	26.7	106	210	P	V
		5150	48.01	-5.99	54	36.63	32	6.08	26.7	106	210	A	V
	*	5230	104.48	-	-	93.55	31.52	6.11	26.7	106	210	P	V
	*	5230	96.87	-	-	85.94	31.52	6.11	26.7	106	210	A	V
	5401.48	50.16	-23.84	74	39.12	31.61	6.12	26.69	106	210	P	V	
	5460	41.29	-12.71	54	29.98	31.82	6.18	26.69	106	210	A	V	
Remark	1. No other spurious found. 2. All results are PASS against Peak and Average limit line.												



Band 1 5150~5250MHz
WIFI 802.11ac VHT40 (Harmonic @ 3m)

WIFI Ant. 1+2	Note	Frequency (MHz)	Level (dBμV/m)	Over Limit (dB)	Limit Line (dBμV/m)	Read Level (dBμV)	Antenna Factor (dB/m)	Path Loss (dB)	Preamp Factor (dB)	Ant Pos (cm)	Table Pos (deg)	Peak Avg. (P/A)	Pol. (H/V)	
802.11ac VHT40 CH 38 5190MHz		10380	46.93	-21.27	68.2	54.14	39.82	9.92	56.95	100	0	P	H	
		15570	46.02	-27.98	74	51.4	38.58	12.66	56.62	100	0	P	H	
													H	
													H	
			10380	46.61	-21.59	68.2	53.82	39.82	9.92	56.95	100	0	P	V
			15570	46.18	-27.82	74	51.56	38.58	12.66	56.62	100	0	P	V
														V
802.11ac VHT40 CH 46 5230MHz		10460	47.58	-20.62	68.2	54.58	39.96	9.96	56.92	100	0	P	H	
		15690	45.05	-28.95	74	50.67	38.13	12.72	56.47	100	0	P	H	
													H	
													H	
			10460	47.36	-20.84	68.2	54.36	39.96	9.96	56.92	100	0	P	V
			15690	45.15	-28.85	74	50.77	38.13	12.72	56.47	100	0	P	V
														V
Remark	1. No other spurious found.													
	2. All results are PASS against Peak and Average limit line.													



Band 1 5150~5250MHz
WIFI 802.11ac VHT80 (Band Edge @ 3m)

WIFI Ant. 1+2	Note	Frequency (MHz)	Level (dBμV/m)	Over Limit (dB)	Limit Line (dBμV/m)	Read Level (dBμV)	Antenna Factor (dB/m)	Path Loss (dB)	Preamp Factor (dB)	Ant Pos (cm)	Table Pos (deg)	Peak Avg. (P/A)	Pol. (H/V)
802.11ac VHT80 CH 42 5210MHz		5142.22	60.97	-13.03	74	49.59	32	6.08	26.7	136	285	P	H
		5148.2	50.69	-3.31	54	39.31	32	6.08	26.7	136	285	A	H
	*	5210	98.85	-	-	87.8	31.64	6.11	26.7	136	285	P	H
	*	5210	90.26	-	-	79.21	31.64	6.11	26.7	136	285	A	H
		5447.96	51.72	-22.28	74	40.45	31.79	6.17	26.69	136	285	P	H
		5459.72	41.5	-12.5	54	30.19	31.82	6.18	26.69	136	285	A	H
		5147.68	54.54	-19.46	74	43.16	32	6.08	26.7	300	240	P	V
		5149.24	44.29	-9.71	54	32.91	32	6.08	26.7	300	240	A	V
	*	5210	91.63	-	-	80.58	31.64	6.11	26.7	300	240	P	V
	*	5210	83.43	-	-	72.38	31.64	6.11	26.7	300	240	A	V
		5458.04	51.26	-22.74	74	39.95	31.82	6.18	26.69	300	240	P	V
		5458.6	41.43	-12.57	54	30.12	31.82	6.18	26.69	300	240	A	V
Remark	1. No other spurious found. 2. All results are PASS against Peak and Average limit line.												



**Band 1 5150~5250MHz
WIFI 802.11ac VHT80 (Harmonic @ 3m)**

WIFI Ant. 1+2	Note	Frequency (MHz)	Level (dBμV/m)	Over Limit (dB)	Limit Line (dBμV/m)	Read Level (dBμV)	Antenna Factor (dB/m)	Path Loss (dB)	Preamp Factor (dB)	Ant Pos (cm)	Table Pos (deg)	Peak Avg. (P/A)	Pol. (H/V)	
802.11ac VHT80 CH 42 5210MHz		10420	47.61	-20.59	68.2	54.68	39.92	9.94	56.93	100	0	P	H	
		15630	45.82	-28.18	74	51.35	38.31	12.7	56.54	100	0	P	H	
													H	
													H	
			10420	46.87	-21.33	68.2	53.94	39.92	9.94	56.93	100	0	P	V
			15630	45.63	-28.37	74	51.16	38.31	12.7	56.54	100	0	P	V
														V
														V
Remark	1. No other spurious found. 2. All results are PASS against Peak and Average limit line.													



Emission below 1GHz
WIFI 802.11ac VHT80 (LF @ 3m)

WIFI	Note	Frequency	Level	Over	Limit	Read	Antenna	Path	Preamp	Ant	Table	Peak	Pol.	
Ant.				Limit	Line	Level	Factor	Loss	Factor	Pos	Pos	Avg.		
1+2		(MHz)	(dBμV/m)	(dB)	(dBμV/m)	(dBμV)	(dB/m)	(dB)	(dB)	(cm)	(deg)	(P/A)	(H/V)	
802.11ac VHT80 LF		155.13	18.71	-24.79	43.5	33.29	16.57	1.07	32.22	-	-	P	H	
		259.89	23.46	-22.54	46	34.53	19.68	1.37	32.12	-	-	P	H	
		756.53	30.97	-15.03	46	32.64	27.8	2.34	31.81	-	-	P	H	
		836.07	32.03	-13.97	46	32.85	28.44	2.57	31.83	-	-	P	H	
		903.97	39.57	-6.43	46	39.76	28.78	2.61	31.58	100	0	P	H	
		947.62	33.75	-12.25	46	31.76	30.36	2.66	31.03	-	-	P	H	
														H
														H
														H
														H
														H
														H
			31.94	29.29	-10.71	40	37.42	23.64	0.46	32.23	-	-	P	V
			42.61	26.92	-13.08	40	40.65	18.03	0.52	32.28	-	-	P	V
			836.07	32.76	-13.24	46	33.58	28.44	2.57	31.83	-	-	P	V
			896.21	38.19	-7.81	46	38.52	28.7	2.61	31.64	-	-	P	V
			903.97	39.95	-6.05	46	40.14	28.78	2.61	31.58	100	0	P	V
			959.26	33.68	-12.32	46	31.19	30.69	2.68	30.88	-	-	P	V
														V
														V
													V	
													V	
													V	
													V	
Remark	1. No other spurious found. 2. All results are PASS against limit line.													



Band 1 - 5150~5250MHz

WIFI 802.11ax HE20 (Band Edge @ 3m)

WIFI	Note	Frequency	Level	Over	Limit	Read	Antenna	Path	Preamp	Ant	Table	Peak	Pol.	
Ant.				Limit	Line	Level	Factor	Loss	Factor	Pos	Pos	Avg.		
1+2		(MHz)	(dBμV/m)	(dB)	(dBμV/m)	(dBμV)	(dB/m)	(dB)	(dB)	(cm)	(deg)	(P/A)	(H/V)	
802.11ax HE20 CH 36 5180MHz		5150	58.82	-15.18	74	47.44	32	6.08	26.7	100	306	P	H	
		5150	49.48	-4.52	54	38.1	32	6.08	26.7	100	306	A	H	
	*	5180	109.34	-	-	98.12	31.82	6.1	26.7	100	306	P	H	
	*	5180	99.32	-	-	88.1	31.82	6.1	26.7	100	306	A	H	
													H	
														H
			5148.46	56.24	-17.76	74	44.86	32	6.08	26.7	239	359	P	V
			5150	46.54	-7.46	54	35.16	32	6.08	26.7	239	359	A	V
	*		5180	107.75	-	-	96.53	31.82	6.1	26.7	239	359	P	V
	*		5180	97.3	-	-	86.08	31.82	6.1	26.7	239	359	A	V
													V	
													V	
802.11ax HE20 CH 44 5220MHz		5138.84	56.77	-17.23	74	45.39	32	6.08	26.7	104	306	P	H	
		5150	48.92	-5.08	54	37.54	32	6.08	26.7	104	306	A	H	
	*	5220	111.28	-	-	100.29	31.58	6.11	26.7	104	306	P	H	
	*	5220	102.11	-	-	91.12	31.58	6.11	26.7	104	306	A	H	
			5456.36	50.67	-23.33	74	39.37	31.81	6.18	26.69	104	306	P	H
			5458.88	41.13	-12.87	54	29.82	31.82	6.18	26.69	104	306	A	H
			5144.3	53.88	-20.12	74	42.5	32	6.08	26.7	249	1	P	V
			5150	44.05	-9.95	54	32.67	32	6.08	26.7	249	1	A	V
	*		5220	108.98	-	-	97.99	31.58	6.11	26.7	249	1	P	V
	*		5220	99.84	-	-	88.85	31.58	6.11	26.7	249	1	A	V
		5429.76	51.03	-22.97	74	39.85	31.72	6.15	26.69	249	1	P	V	
		5458.32	41.13	-12.87	54	29.82	31.82	6.18	26.69	249	1	A	V	



802.11ax HE20 CH 48 5240MHz		5145.08	56.78	-17.22	74	45.4	32	6.08	26.7	102	316	P	H
		5149.5	47.52	-6.48	54	36.14	32	6.08	26.7	102	316	A	H
	*	5240	113.43	-	-	102.56	31.46	6.11	26.7	102	316	P	H
	*	5240	104.33	-	-	93.46	31.46	6.11	26.7	102	316	A	H
		5352.48	52.61	-21.39	74	41.78	31.41	6.12	26.7	102	316	P	H
		5350.24	42.62	-11.38	54	31.8	31.4	6.12	26.7	102	316	A	H
		5134.68	54.16	-19.84	74	42.79	32	6.07	26.7	383	297	P	V
		5150	44.01	-9.99	54	32.63	32	6.08	26.7	383	297	A	V
	*	5240	108.98	-	-	98.11	31.46	6.11	26.7	383	297	P	V
	*	5240	99.36	-	-	88.49	31.46	6.11	26.7	383	297	A	V
		5353.6	53.15	-20.85	74	42.32	31.41	6.12	26.7	383	297	P	V
		5350.24	41.99	-12.01	54	31.17	31.4	6.12	26.7	383	297	A	V
Remark	1. No other spurious found. 2. All results are PASS against Peak and Average limit line.												



Band 1 5150~5250MHz
WIFI 802.11ax HE20 (Harmonic @ 3m)

WIFI Ant. 1+2	Note	Frequency (MHz)	Level (dBμV/m)	Over Limit (dB)	Limit Line (dBμV/m)	Read Level (dBμV)	Antenna Factor (dB/m)	Path Loss (dB)	Preamp Factor (dB)	Ant Pos (cm)	Table Pos (deg)	Peak Avg. (P/A)	Pol. (H/V)
802.11ax HE20 CH 36 5180MHz		10360	46.64	-21.56	68.2	53.95	39.74	9.91	56.96	100	0	P	H
		15540	46.04	-27.96	74	51.28	38.76	12.65	56.65	100	0	P	H
													H
													H
		10360	46.8	-21.4	68.2	54.11	39.74	9.91	56.96	100	0	P	V
		15540	46.06	-27.94	74	51.3	38.76	12.65	56.65	100	0	P	V
													V
802.11ax HE20 CH 44 5220MHz		10440	47.76	-20.44	68.2	54.79	39.94	9.95	56.92	100	0	P	H
		15660	45.83	-28.17	74	51.4	38.22	12.72	56.51	100	0	P	H
													H
													H
		10440	47.53	-20.67	68.2	54.56	39.94	9.95	56.92	100	0	P	V
		15660	45.92	-28.08	74	51.49	38.22	12.72	56.51	100	0	P	V
													V
802.11ax HE20 CH 48 5240MHz		10480	48.51	-19.69	68.2	55.47	39.98	9.97	56.91	100	0	P	H
		15720	48.94	-25.06	74	54.54	38.1	12.74	56.44	100	0	P	H
													H
													H
		10480	47.66	-20.54	68.2	54.62	39.98	9.97	56.91	100	0	P	V
		15720	47.25	-26.75	74	52.85	38.1	12.74	56.44	100	0	P	V
													V
Remark	1. No other spurious found.												
	2. All results are PASS against Peak and Average limit line.												



Band 1 5150~5250MHz
WIFI 802.11ax HE40 (Band Edge @ 3m)

WIFI Ant. 1+2	Note	Frequency (MHz)	Level (dBμV/m)	Over Limit (dB)	Limit Line (dBμV/m)	Read Level (dBμV)	Antenna Factor (dB/m)	Path Loss (dB)	Preamp Factor (dB)	Ant Pos (cm)	Table Pos (deg)	Peak Avg. (P/A)	Pol. (H/V)
802.11ax HE40 CH 38 5190MHz		5148.2	59.3	-14.7	74	47.92	32	6.08	26.7	103	307	P	H
		5150	47.61	-6.39	54	36.23	32	6.08	26.7	103	307	A	H
	*	5190	103.85	-	-	92.69	31.76	6.1	26.7	103	307	P	H
	*	5190	95.01	-	-	83.85	31.76	6.1	26.7	103	307	A	H
		5458.32	50.25	-23.75	74	38.94	31.82	6.18	26.69	103	307	P	H
		5460	41.12	-12.88	54	29.81	31.82	6.18	26.69	103	307	A	H
		5149.76	56.45	-17.55	74	45.07	32	6.08	26.7	264	4	P	V
		5150	46.19	-7.81	54	34.81	32	6.08	26.7	264	4	A	V
	*	5190	102.03	-	-	90.87	31.76	6.1	26.7	264	4	P	V
	*	5190	93.05	-	-	81.89	31.76	6.1	26.7	264	4	A	V
		5439.28	50.13	-23.87	74	38.9	31.76	6.16	26.69	264	4	P	V
		5458.6	41.11	-12.89	54	29.8	31.82	6.18	26.69	264	4	A	V
802.11ax HE40 CH 46 5230MHz		5147.42	56.74	-17.26	74	45.36	32	6.08	26.7	102	306	P	H
		5149.76	48.36	-5.64	54	36.98	32	6.08	26.7	102	306	A	H
	*	5230	106.33	-	-	95.4	31.52	6.11	26.7	102	306	P	H
	*	5230	97.97	-	-	87.04	31.52	6.11	26.7	102	306	A	H
		5446	50.67	-23.33	74	39.41	31.78	6.17	26.69	102	306	P	H
		5459.72	41.15	-12.85	54	29.84	31.82	6.18	26.69	102	306	A	H
		5148.46	56.15	-17.85	74	44.77	32	6.08	26.7	278	355	P	V
		5149.5	46.58	-7.42	54	35.2	32	6.08	26.7	278	355	A	V
	*	5230	104.26	-	-	93.33	31.52	6.11	26.7	278	355	P	V
	*	5230	95.94	-	-	85.01	31.52	6.11	26.7	278	355	A	V
	5451.6	50.43	-23.57	74	39.15	31.8	6.17	26.69	278	355	P	V	
	5459.16	41.15	-12.85	54	29.84	31.82	6.18	26.69	278	355	A	V	
Remark	1. No other spurious found. 2. All results are PASS against Peak and Average limit line.												



Band 1 5150~5250MHz

WIFI 802.11ax HE40 (Harmonic @ 3m)

WIFI Ant. 1+2	Note	Frequency (MHz)	Level (dBμV/m)	Over Limit (dB)	Limit Line (dBμV/m)	Read Level (dBμV)	Antenna Factor (dB/m)	Path Loss (dB)	Preamp Factor (dB)	Ant Pos (cm)	Table Pos (deg)	Peak Avg. (P/A)	Pol. (H/V)	
802.11ax HE40 CH 38 5190MHz		10380	46.65	-21.55	68.2	53.86	39.82	9.92	56.95	100	0	P	H	
		15570	46.25	-27.75	74	51.63	38.58	12.66	56.62	100	0	P	H	
													H	
													H	
			10380	47.7	-20.5	68.2	54.91	39.82	9.92	56.95	100	0	P	V
			15570	46.62	-27.38	74	52	38.58	12.66	56.62	100	0	P	V
														V
802.11ax HE40 CH 46 5230MHz		10460	47.13	-21.07	68.2	54.13	39.96	9.96	56.92	100	0	P	H	
		15690	45.3	-28.7	74	50.92	38.13	12.72	56.47	100	0	P	H	
													H	
													H	
			10460	47.75	-20.45	68.2	54.75	39.96	9.96	56.92	100	0	P	V
			15690	46.73	-27.27	74	52.35	38.13	12.72	56.47	100	0	P	V
														V
Remark	1. No other spurious found.													
	2. All results are PASS against Peak and Average limit line.													



Band 1 5150~5250MHz
WIFI 802.11ax HE80 (Band Edge @ 3m)

WIFI Ant. 1+2	Note	Frequency (MHz)	Level (dBμV/m)	Over Limit (dB)	Limit Line (dBμV/m)	Read Level (dBμV)	Antenna Factor (dB/m)	Path Loss (dB)	Preamp Factor (dB)	Ant Pos (cm)	Table Pos (deg)	Peak Avg. (P/A)	Pol. (H/V)
802.11ax HE80 CH 42 5210MHz		5142.22	58.07	-15.93	74	46.69	32	6.08	26.7	112	307	P	H
		5148.2	48.8	-5.2	54	37.42	32	6.08	26.7	112	307	A	H
	*	5210	101.97	-	-	90.92	31.64	6.11	26.7	112	307	P	H
	*	5210	92.79	-	-	81.74	31.64	6.11	26.7	112	307	A	H
		5450.76	50.46	-23.54	74	39.18	31.8	6.17	26.69	112	307	P	H
		5460	41.17	-12.83	54	29.86	31.82	6.18	26.69	112	307	A	H
		5144.56	56.58	-17.42	74	45.2	32	6.08	26.7	224	0	P	V
		5148.98	47.2	-6.8	54	35.82	32	6.08	26.7	224	0	A	V
	*	5210	98.76	-	-	87.71	31.64	6.11	26.7	224	0	P	V
	*	5210	89.76	-	-	78.71	31.64	6.11	26.7	224	0	A	V
		5419.68	50.04	-23.96	74	38.91	31.68	6.14	26.69	224	0	P	V
		5458.32	41.15	-12.85	54	29.84	31.82	6.18	26.69	224	0	A	V
Remark	1. No other spurious found. 2. All results are PASS against Peak and Average limit line.												



Band 1 5150~5250MHz

WIFI 802.11ax HE80 (Harmonic @ 3m)

WIFI Ant. 1+2	Note	Frequency (MHz)	Level (dBμV/m)	Over Limit (dB)	Limit Line (dBμV/m)	Read Level (dBμV)	Antenna Factor (dB/m)	Path Loss (dB)	Preamp Factor (dB)	Ant Pos (cm)	Table Pos (deg)	Peak Avg. (P/A)	Pol. (H/V)
802.11ax HE80		10420	47.9	-20.3	68.2	54.97	39.92	9.94	56.93	100	0	P	H
		15630	45.21	-28.79	74	50.74	38.31	12.7	56.54	100	0	P	H
													H
													H
CH 42 5210MHz		10420	47.29	-20.91	68.2	54.36	39.92	9.94	56.93	100	0	P	V
		15630	45.49	-28.51	74	51.02	38.31	12.7	56.54	100	0	P	V
													V
													V
Remark	1. No other spurious found. 2. All results are PASS against Peak and Average limit line.												



Band 1 5150~5250MHz

WIFI 802.11ax HE20 (Partial RU 26/0) (Band Edge @ 3m)

WIFI Ant. 1+2	Note	Frequency (MHz)	Level (dBμV/m)	Over Limit (dB)	Limit Line (dBμV/m)	Read Level (dBμV)	Antenna Factor (dB/m)	Path Loss (dB)	Preamp Factor (dB)	Ant Pos (cm)	Table Pos (deg)	Peak Avg. (P/A)	Pol. (H/V)	
802.11ax HE20 26/0 RU CH 36 5180MHz		5049.4	52.78	-21.22	74	41.66	31.8	6.03	26.71	150	318	P	H	
		5095.16	42.38	-11.62	54	31.06	31.98	6.05	26.71	150	318	A	H	
	*	5180	108.48	-	-	97.26	31.82	6.1	26.7	150	318	P	H	
	*	5180	102.18	-	-	90.96	31.82	6.1	26.7	150	318	A	H	
													H	
														H
			5126.88	52.78	-21.22	74	41.41	32	6.07	26.7	238	14	P	V
			5095.16	42.29	-11.71	54	30.97	31.98	6.05	26.71	238	14	A	V
	*		5180	108.04	-	-	96.82	31.82	6.1	26.7	238	14	P	V
	*		5180	101.97	-	-	90.75	31.82	6.1	26.7	238	14	A	V
														V
														V
Remark	1. No other spurious found. 2. All results are PASS against Peak and Average limit line.													



Band 1 5150~5250MHz

WIFI 802.11ax HE20 (Partial RU 52/37) (Band Edge @ 3m)

WIFI Ant. 1+2	Note	Frequency (MHz)	Level (dBμV/m)	Over Limit (dB)	Limit Line (dBμV/m)	Read Level (dBμV)	Antenna Factor (dB/m)	Path Loss (dB)	Preamp Factor (dB)	Ant Pos (cm)	Table Pos (deg)	Peak Avg. (P/A)	Pol. (H/V)	
802.11ax HE20 52/37 RU CH 36 5180MHz		5051.74	53.02	-20.98	74	41.89	31.81	6.03	26.71	150	317	P	H	
		5096.98	42.29	-11.71	54	30.96	31.99	6.05	26.71	150	317	A	H	
	*	5180	110.02	-	-	98.8	31.82	6.1	26.7	150	317	P	H	
	*	5180	100.98	-	-	89.76	31.82	6.1	26.7	150	317	A	H	
													H	
														H
			5086.84	52.54	-21.46	74	41.25	31.95	6.05	26.71	254	12	P	V
			5096.98	42.25	-11.75	54	30.92	31.99	6.05	26.71	254	12	A	V
		*	5180	108.56	-	-	97.34	31.82	6.1	26.7	254	12	P	V
		*	5180	100.67	-	-	89.45	31.82	6.1	26.7	254	12	A	V
														V
														V
Remark	1. No other spurious found. 2. All results are PASS against Peak and Average limit line.													



Band 1 5150~5250MHz

WIFI 802.11ax HE20 (Partial RU 106/53) (Band Edge @ 3m)

WIFI Ant. 1+2	Note	Frequency (MHz)	Level (dBμV/m)	Over Limit (dB)	Limit Line (dBμV/m)	Read Level (dBμV)	Antenna Factor (dB/m)	Path Loss (dB)	Preamp Factor (dB)	Ant Pos (cm)	Table Pos (deg)	Peak Avg. (P/A)	Pol. (H/V)	
802.11ax HE20 106/53 RU CH 36 5180MHz		5150	54.99	-19.01	74	43.61	32	6.08	26.7	106	313	P	H	
		5097.5	42.26	-11.74	54	30.93	31.99	6.05	26.71	106	313	A	H	
	*	5180	109.84	-	-	98.62	31.82	6.1	26.7	106	313	P	H	
	*	5180	101.56	-	-	90.34	31.82	6.1	26.7	106	313	A	H	
													H	
														H
			5082.16	53.1	-20.9	74	41.83	31.93	6.05	26.71	241	12	P	V
			5098.54	42.3	-11.7	54	30.97	31.99	6.05	26.71	241	12	A	V
	*		5180	108.51	-	-	97.29	31.82	6.1	26.7	241	12	P	V
	*		5180	100.4	-	-	89.18	31.82	6.1	26.7	241	12	A	V
														V
														V
Remark	1. No other spurious found. 2. All results are PASS against Peak and Average limit line.													



Band 1 5150~5250MHz

WIFI 802.11ax HE40 (Partial RU 242/61) (Band Edge @ 3m)

WIFI Ant. 1+2	Note	Frequency (MHz)	Level (dBμV/m)	Over Limit (dB)	Limit Line (dBμV/m)	Read Level (dBμV)	Antenna Factor (dB/m)	Path Loss (dB)	Preamp Factor (dB)	Ant Pos (cm)	Table Pos (deg)	Peak Avg. (P/A)	Pol. (H/V)
802.11ax HE40 242/61 RU CH 38 5190MHz		5150	67.29	-6.71	74	55.91	32	6.08	26.7	100	311	P	H
		5150	50.19	-3.81	54	38.81	32	6.08	26.7	100	311	A	H
	*	5190	108.73	-	-	97.57	31.76	6.1	26.7	100	311	P	H
	*	5190	99.43	-	-	88.27	31.76	6.1	26.7	100	311	A	H
		5454.12	50.83	-23.17	74	39.54	31.81	6.17	26.69	100	311	P	H
		5459.72	41.23	-12.77	54	29.92	31.82	6.18	26.69	100	311	A	H
		5148.2	60.45	-13.55	74	49.07	32	6.08	26.7	239	14	P	V
		5150	49.44	-4.56	54	38.06	32	6.08	26.7	239	14	A	V
	*	5190	107.47	-	-	96.31	31.76	6.1	26.7	239	14	P	V
	*	5190	98.18	-	-	87.02	31.76	6.1	26.7	239	14	A	V
		5444.88	50.02	-23.98	74	38.77	31.78	6.16	26.69	239	14	P	V
		5460	41.24	-12.76	54	29.93	31.82	6.18	26.69	239	14	A	V
	Remark	1. No other spurious found. 2. All results are PASS against Peak and Average limit line.											



Band 1 5150~5250MHz

WIFI 802.11ax HE80 (Partial RU 484/65) (Band Edge @ 3m)

WIFI Ant. 1+2	Note	Frequency (MHz)	Level (dBμV/m)	Over Limit (dB)	Limit Line (dBμV/m)	Read Level (dBμV)	Antenna Factor (dB/m)	Path Loss (dB)	Preamp Factor (dB)	Ant Pos (cm)	Table Pos (deg)	Peak Avg. (P/A)	Pol. (H/V)
802.11ax HE80 484/65 RU CH 42 5210MHz		5149.5	60.59	-13.41	74	49.21	32	6.08	26.7	111	314	P	H
		5150	48.56	-5.44	54	37.18	32	6.08	26.7	111	314	A	H
	*	5210	105.13	-	-	94.08	31.64	6.11	26.7	111	314	P	H
	*	5210	94.55	-	-	83.5	31.64	6.11	26.7	111	314	A	H
		5398.68	51.86	-22.14	74	40.84	31.59	6.12	26.69	111	314	P	H
		5459.16	41.24	-12.76	54	29.93	31.82	6.18	26.69	111	314	A	H
		5147.94	56.62	-17.38	74	45.24	32	6.08	26.7	249	15	P	V
		5148.46	47.49	-6.51	54	36.11	32	6.08	26.7	249	15	A	V
	*	5210	102.3	-	-	91.25	31.64	6.11	26.7	249	15	P	V
	*	5210	93.6	-	-	82.55	31.64	6.11	26.7	249	15	A	V
		5414.64	51.48	-22.52	74	40.38	31.66	6.13	26.69	249	15	P	V
		5460	41.22	-12.78	54	29.91	31.82	6.18	26.69	249	15	A	V
Remark	<ol style="list-style-type: none"> No other spurious found. All results are PASS against Peak and Average limit line. 												



<TXBF Mode>

Band 1 - 5150~5250MHz

WIFI 802.11ac VHT20 (Band Edge @ 3m)

WIFI Ant.	Note	Frequency	Level	Over Limit	Limit Line	Read Level	Antenna Factor	Path Loss	Preamp Factor	Ant Pos	Table Pos	Peak Avg.	Pol.	
1+2		(MHz)	(dBμV/m)	(dB)	(dBμV/m)	(dBμV)	(dB/m)	(dB)	(dB)	(cm)	(deg)	(P/A)	(H/V)	
802.11ac VHT20 CH 36 5180MHz		5073.84	53.3	-20.7	74	42.07	31.9	6.04	26.71	123	25	P	H	
		5101.14	42.22	-11.78	54	30.87	32	6.06	26.71	123	25	A	H	
	*	5180	99.83	-	-	88.61	31.82	6.1	26.7	123	25	P	H	
	*	5180	91.2	-	-	79.98	31.82	6.1	26.7	123	25	A	H	
													H	
														H
			5113.36	52.51	-21.49	74	41.16	32	6.06	26.71	202	349	P	V
			5100.36	42.19	-11.81	54	30.84	32	6.06	26.71	202	349	A	V
		*	5180	103.32	-	-	92.1	31.82	6.1	26.7	202	349	P	V
		*	5180	91.5	-	-	80.28	31.82	6.1	26.7	202	349	A	V
													V	
													V	
802.11ac VHT20 CH 44 5220MHz		5136.76	51.64	-22.36	74	40.26	32	6.08	26.7	146	29	P	H	
		5101.4	42.21	-11.79	54	30.86	32	6.06	26.71	146	29	A	H	
	*	5220	102.81	-	-	91.82	31.58	6.11	26.7	146	29	P	H	
	*	5220	92	-	-	81.01	31.58	6.11	26.7	146	29	A	H	
			5447.96	50.23	-23.77	74	38.96	31.79	6.17	26.69	146	29	P	H
			5460	41.12	-12.88	54	29.81	31.82	6.18	26.69	146	29	A	H
			5145.34	51.4	-22.6	74	40.02	32	6.08	26.7	191	360	P	V
			5089.44	42.21	-11.79	54	30.91	31.96	6.05	26.71	191	360	A	V
		*	5220	102.2	-	-	91.21	31.58	6.11	26.7	191	360	P	V
		*	5220	91.28	-	-	80.29	31.58	6.11	26.7	191	360	A	V
		5432.84	51.23	-22.77	74	40.04	31.73	6.15	26.69	191	360	P	V	
		5459.16	41.04	-12.96	54	29.73	31.82	6.18	26.69	191	360	A	V	



802.11ac VHT20 CH 48 5240MHz		5059.8	52.89	-21.11	74	41.73	31.84	6.03	26.71	207	36	P	H
		5094.9	42.19	-11.81	54	30.87	31.98	6.05	26.71	207	36	A	H
	*	5240	102.26	-	-	91.39	31.46	6.11	26.7	207	36	P	H
	*	5240	91.82	-	-	80.95	31.46	6.11	26.7	207	36	A	H
		5451.32	51.37	-22.63	74	40.09	31.8	6.17	26.69	207	36	P	H
		5459.72	40.97	-13.03	54	29.66	31.82	6.18	26.69	207	36	A	H
		5077.22	51.88	-22.12	74	40.64	31.91	6.04	26.71	194	345	P	V
		5102.18	42.18	-11.82	54	30.83	32	6.06	26.71	194	345	A	V
	*	5240	102.76	-	-	91.89	31.46	6.11	26.7	194	345	P	V
	*	5240	90.92	-	-	80.05	31.46	6.11	26.7	194	345	A	V
		5403.72	50.62	-23.38	74	39.58	31.61	6.12	26.69	194	345	P	V
		5459.44	40.99	-13.01	54	29.68	31.82	6.18	26.69	194	345	A	V
Remark	1. No other spurious found. 2. All results are PASS against Peak and Average limit line.												



Band 1 5150~5250MHz
WIFI 802.11ac VHT20 (Harmonic @ 3m)

WIFI Ant. 1+2	Note	Frequency (MHz)	Level (dBμV/m)	Over Limit (dB)	Limit Line (dBμV/m)	Read Level (dBμV)	Antenna Factor (dB/m)	Path Loss (dB)	Preamp Factor (dB)	Ant Pos (cm)	Table Pos (deg)	Peak Avg. (P/A)	Pol. (H/V)	
802.11ac VHT20 CH 36 5180MHz		10360	46.96	-21.24	68.2	54.27	39.74	9.91	56.96	100	0	P	H	
		15540	45.97	-28.03	74	51.21	38.76	12.65	56.65	100	0	P	H	
													H	
													H	
			10360	46.11	-22.09	68.2	53.42	39.74	9.91	56.96	100	0	P	V
			15540	44.47	-29.53	74	49.71	38.76	12.65	56.65	100	0	P	V
														V
802.11ac VHT20 CH 44 5220MHz		10440	46.05	-22.15	68.2	53.08	39.94	9.95	56.92	100	0	P	H	
		15660	43.38	-30.62	74	48.95	38.22	12.72	56.51	100	0	P	H	
													H	
													H	
			10440	46.37	-21.83	68.2	53.4	39.94	9.95	56.92	100	0	P	V
			15660	45.09	-28.91	74	50.66	38.22	12.72	56.51	100	0	P	V
														V
802.11ac VHT20 CH 48 5240MHz		10480	47	-21.2	68.2	53.96	39.98	9.97	56.91	100	0	P	H	
		15720	45.05	-28.95	74	50.65	38.1	12.74	56.44	100	0	P	H	
													H	
													H	
			10480	46.36	-21.84	68.2	53.32	39.98	9.97	56.91	100	0	P	V
			15720	45.14	-28.86	74	50.74	38.1	12.74	56.44	100	0	P	V
														V
Remark	1. No other spurious found.													
	2. All results are PASS against Peak and Average limit line.													



Band 1 5150~5250MHz
WIFI 802.11ac VHT40 (Band Edge @ 3m)

WIFI Ant. 1+2	Note	Frequency (MHz)	Level (dBμV/m)	Over Limit (dB)	Limit Line (dBμV/m)	Read Level (dBμV)	Antenna Factor (dB/m)	Path Loss (dB)	Preamp Factor (dB)	Ant Pos (cm)	Table Pos (deg)	Peak Avg. (P/A)	Pol. (H/V)
802.11ac VHT40 CH 38 5190MHz		5139.88	51.95	-22.05	74	40.57	32	6.08	26.7	198	35	P	H
		5148.46	42.86	-11.14	54	31.48	32	6.08	26.7	198	35	A	H
	*	5190	100.68	-	-	89.52	31.76	6.1	26.7	198	35	P	H
	*	5190	89.45	-	-	78.29	31.76	6.1	26.7	198	35	A	H
		5434.24	50.08	-23.92	74	38.88	31.74	6.15	26.69	198	35	P	H
		5460	41.11	-12.89	54	29.8	31.82	6.18	26.69	198	35	A	H
		5106.86	51.59	-22.41	74	40.24	32	6.06	26.71	215	340	P	V
		5149.76	42.9	-11.1	54	31.52	32	6.08	26.7	215	340	A	V
	*	5190	101.08	-	-	89.92	31.76	6.1	26.7	215	340	P	V
	*	5190	87.87	-	-	76.71	31.76	6.1	26.7	215	340	A	V
		5441.24	49.94	-24.06	74	38.71	31.76	6.16	26.69	215	340	P	V
		5459.72	41.14	-12.86	54	29.83	31.82	6.18	26.69	215	340	A	V
802.11ac VHT40 CH 46 5230MHz		5089.7	52.89	-21.11	74	41.59	31.96	6.05	26.71	186	33	P	H
		5099.06	42.25	-11.75	54	30.91	32	6.05	26.71	186	33	A	H
	*	5230	101.46	-	-	90.53	31.52	6.11	26.7	186	33	P	H
	*	5230	90.09	-	-	79.16	31.52	6.11	26.7	186	33	A	H
		5438.44	52.13	-21.87	74	40.91	31.75	6.16	26.69	186	33	P	H
		5459.16	41.15	-12.85	54	29.84	31.82	6.18	26.69	186	33	A	H
		5106.86	51.87	-22.13	74	40.52	32	6.06	26.71	260	360	P	V
		5098.28	42.24	-11.76	54	30.91	31.99	6.05	26.71	260	360	A	V
	*	5230	101.99	-	-	91.06	31.52	6.11	26.7	260	360	P	V
	*	5230	89.52	-	-	78.59	31.52	6.11	26.7	260	360	A	V
	5444.88	50.29	-23.71	74	39.04	31.78	6.16	26.69	260	360	P	V	
	5460	41.15	-12.85	54	29.84	31.82	6.18	26.69	260	360	A	V	
Remark	1. No other spurious found. 2. All results are PASS against Peak and Average limit line.												



Band 1 5150~5250MHz
WIFI 802.11ac VHT40 (Harmonic @ 3m)

WIFI Ant. 1+2	Note	Frequency (MHz)	Level (dBμV/m)	Over Limit (dB)	Limit Line (dBμV/m)	Read Level (dBμV)	Antenna Factor (dB/m)	Path Loss (dB)	Preamp Factor (dB)	Ant Pos (cm)	Table Pos (deg)	Peak Avg. (P/A)	Pol. (H/V)	
802.11ac VHT40 CH 38 5190MHz		10380	46.91	-21.29	68.2	54.12	39.82	9.92	56.95	100	0	P	H	
		15570	44.92	-29.08	74	50.3	38.58	12.66	56.62	100	0	P	H	
													H	
													H	
			10380	46.23	-21.97	68.2	53.44	39.82	9.92	56.95	100	0	P	V
			15570	44.16	-29.84	74	49.54	38.58	12.66	56.62	100	0	P	V
														V
802.11ac VHT40 CH 46 5230MHz		10460	47.27	-20.93	68.2	54.27	39.96	9.96	56.92	100	0	P	H	
		15690	43.92	-30.08	74	49.54	38.13	12.72	56.47	100	0	P	H	
													H	
													H	
			10460	46.39	-21.81	68.2	53.39	39.96	9.96	56.92	100	0	P	V
			15690	43.82	-30.18	74	49.44	38.13	12.72	56.47	100	0	P	V
														V
Remark	1. No other spurious found.													
	2. All results are PASS against Peak and Average limit line.													



Band 1 5150~5250MHz
WIFI 802.11ac VHT80 (Band Edge @ 3m)

WIFI Ant. 1+2	Note	Frequency (MHz)	Level (dBμV/m)	Over Limit (dB)	Limit Line (dBμV/m)	Read Level (dBμV)	Antenna Factor (dB/m)	Path Loss (dB)	Preamp Factor (dB)	Ant Pos (cm)	Table Pos (deg)	Peak Avg. (P/A)	Pol. (H/V)
802.11ac VHT80 CH 42 5210MHz		5138.58	58.05	-15.95	74	46.67	32	6.08	26.7	181	25	P	H
		5149.76	46.69	-7.31	54	35.31	32	6.08	26.7	181	25	A	H
	*	5210	97.18	-	-	86.13	31.64	6.11	26.7	181	25	P	H
	*	5210	87.84	-	-	76.79	31.64	6.11	26.7	181	25	A	H
		5362	50.12	-23.88	74	39.25	31.45	6.12	26.7	181	25	P	H
		5459.72	41.03	-12.97	54	29.72	31.82	6.18	26.69	181	25	A	H
		5142.48	57.73	-16.27	74	46.35	32	6.08	26.7	238	360	P	V
		5150	47.12	-6.88	54	35.74	32	6.08	26.7	238	360	A	V
	*	5210	96.25	-	-	85.2	31.64	6.11	26.7	238	360	P	V
	*	5210	87.75	-	-	76.7	31.64	6.11	26.7	238	360	A	V
		5398.96	50.24	-23.76	74	39.21	31.6	6.12	26.69	238	360	P	V
	5458.88	41.07	-12.93	54	29.76	31.82	6.18	26.69	238	360	A	V	
Remark	1. No other spurious found. 2. All results are PASS against Peak and Average limit line.												



**Band 1 5150~5250MHz
WIFI 802.11ac VHT80 (Harmonic @ 3m)**

WIFI Ant. 1+2	Note	Frequency (MHz)	Level (dBμV/m)	Over Limit (dB)	Limit Line (dBμV/m)	Read Level (dBμV)	Antenna Factor (dB/m)	Path Loss (dB)	Preamp Factor (dB)	Ant Pos (cm)	Table Pos (deg)	Peak Avg. (P/A)	Pol. (H/V)	
802.11ac VHT80 CH 42 5210MHz		10420	46.48	-21.72	68.2	53.55	39.92	9.94	56.93	100	0	P	H	
		15630	44.17	-29.83	74	49.7	38.31	12.7	56.54	100	0	P	H	
													H	
													H	
			10420	46.23	-21.97	68.2	53.3	39.92	9.94	56.93	100	0	P	V
			15630	45.11	-28.89	74	50.64	38.31	12.7	56.54	100	0	P	V
														V
Remark	1. No other spurious found.													
	2. All results are PASS against Peak and Average limit line.													



Band 1 - 5150~5250MHz

WIFI 802.11ax HE20 (Band Edge @ 3m)

WIFI	Note	Frequency	Level	Over	Limit	Read	Antenna	Path	Preamp	Ant	Table	Peak	Pol.	
Ant.				Limit	Line	Level	Factor	Loss	Factor	Pos	Pos	Avg.		
1+2		(MHz)	(dBμV/m)	(dB)	(dBμV/m)	(dBμV)	(dB/m)	(dB)	(dB)	(cm)	(deg)	(P/A)	(H/V)	
802.11ax HE20 CH 36 5180MHz		5146.38	54.78	-19.22	74	43.4	32	6.08	26.7	107	259	P	H	
		5150	43.67	-10.33	54	32.29	32	6.08	26.7	107	259	A	H	
	*	5180	103.83	-	-	92.61	31.82	6.1	26.7	107	259	P	H	
	*	5180	92.85	-	-	81.63	31.82	6.1	26.7	107	259	A	H	
													H	
														H
802.11ax HE20 CH 44 5220MHz		5058.24	53.47	-20.53	74	42.32	31.83	6.03	26.71	120	258	P	H	
		5095.68	42.25	-11.75	54	30.93	31.98	6.05	26.71	120	258	A	H	
	*	5220	102.85	-	-	91.86	31.58	6.11	26.7	120	258	P	H	
	*	5220	92.93	-	-	81.94	31.58	6.11	26.7	120	258	A	H	



802.11ax HE20 CH 48 5240MHz		5086.84	52.92	-21.08	74	41.63	31.95	6.05	26.71	100	257	P	H
		5094.9	42.21	-11.79	54	30.89	31.98	6.05	26.71	100	257	A	H
	*	5240	103.13	-	-	92.26	31.46	6.11	26.7	100	257	P	H
	*	5240	93.43	-	-	82.56	31.46	6.11	26.7	100	257	A	H
		5421.92	50.73	-23.27	74	39.59	31.69	6.14	26.69	100	257	P	H
		5459.44	41.25	-12.75	54	29.94	31.82	6.18	26.69	100	257	A	H
		5107.38	52.63	-21.37	74	41.28	32	6.06	26.71	100	243	P	V
		5086.58	42.18	-11.82	54	30.89	31.95	6.05	26.71	100	243	A	V
	*	5240	100.98	-	-	90.11	31.46	6.11	26.7	100	243	P	V
	*	5240	91.38	-	-	80.51	31.46	6.11	26.7	100	243	A	V
		5451.88	51.15	-22.85	74	39.87	31.8	6.17	26.69	100	243	P	V
		5459.44	41.25	-12.75	54	29.94	31.82	6.18	26.69	100	243	A	V
Remark	1. No other spurious found. 2. All results are PASS against Peak and Average limit line.												



Band 1 5150~5250MHz

WIFI 802.11ax HE20 (Harmonic @ 3m)

WIFI Ant. 1+2	Note	Frequency (MHz)	Level (dBμV/m)	Over Limit (dB)	Limit Line (dBμV/m)	Read Level (dBμV)	Antenna Factor (dB/m)	Path Loss (dB)	Preamp Factor (dB)	Ant Pos (cm)	Table Pos (deg)	Peak Avg. (P/A)	Pol. (H/V)
802.11ax HE20 CH 36 5180MHz		10360	47.59	-20.61	68.2	54.9	39.74	9.91	56.96	100	0	P	H
		15540	45.79	-28.21	74	51.03	38.76	12.65	56.65	100	0	P	H
													H
													H
		10360	47.77	-20.43	68.2	55.08	39.74	9.91	56.96	100	0	P	V
		15540	45.56	-28.44	74	50.8	38.76	12.65	56.65	100	0	P	V
													V
802.11ax HE20 CH 44 5220MHz		10440	47.15	-21.05	68.2	54.18	39.94	9.95	56.92	100	0	P	H
		15660	44.4	-29.6	74	49.97	38.22	12.72	56.51	100	0	P	H
													H
													H
		10440	46.82	-21.38	68.2	53.85	39.94	9.95	56.92	100	0	P	V
		15660	44.38	-29.62	74	49.95	38.22	12.72	56.51	100	0	P	V
													V
802.11ax HE20 CH 48 5240MHz		10480	48.11	-20.09	68.2	55.07	39.98	9.97	56.91	100	0	P	H
		15720	44.67	-29.33	74	50.27	38.1	12.74	56.44	100	0	P	H
													H
													H
		10480	47.39	-20.81	68.2	54.35	39.98	9.97	56.91	100	0	P	V
		15720	44.61	-29.39	74	50.21	38.1	12.74	56.44	100	0	P	V
													V
Remark	1. No other spurious found.												
	2. All results are PASS against Peak and Average limit line.												



Band 1 5150~5250MHz
WIFI 802.11ax HE40 (Band Edge @ 3m)

WIFI Ant. 1+2	Note	Frequency (MHz)	Level (dBμV/m)	Over Limit (dB)	Limit Line (dBμV/m)	Read Level (dBμV)	Antenna Factor (dB/m)	Path Loss (dB)	Preamp Factor (dB)	Ant Pos (cm)	Table Pos (deg)	Peak Avg. (P/A)	Pol. (H/V)
802.11ax HE40 CH 38 5190MHz		5150	64.25	-9.75	74	52.87	32	6.08	26.7	100	258	P	H
		5150	47.75	-6.25	54	36.37	32	6.08	26.7	100	258	A	H
	*	5190	103.84	-	-	92.68	31.76	6.1	26.7	100	258	P	H
	*	5190	91.43	-	-	80.27	31.76	6.1	26.7	100	258	A	H
		5451.32	52.19	-21.81	74	40.91	31.8	6.17	26.69	100	258	P	H
		5460	41.29	-12.71	54	29.98	31.82	6.18	26.69	100	258	A	H
		5148.72	55.72	-18.28	74	44.34	32	6.08	26.7	100	244	P	V
		5149.5	47.31	-6.69	54	35.93	32	6.08	26.7	100	244	A	V
	*	5190	101.02	-	-	89.86	31.76	6.1	26.7	100	244	P	V
	*	5190	89.53	-	-	78.37	31.76	6.1	26.7	100	244	A	V
		5448.52	52.18	-21.82	74	40.91	31.79	6.17	26.69	100	244	P	V
		5459.16	41.24	-12.76	54	29.93	31.82	6.18	26.69	100	244	A	V
802.11ax HE40 CH 46 5230MHz		5053.56	52.78	-21.22	74	41.65	31.81	6.03	26.71	108	260	P	H
		5101.14	42.23	-11.77	54	30.88	32	6.06	26.71	108	260	A	H
	*	5230	103.06	-	-	92.13	31.52	6.11	26.7	108	260	P	H
	*	5230	90.92	-	-	79.99	31.52	6.11	26.7	108	260	A	H
		5458.32	51.29	-22.71	74	39.98	31.82	6.18	26.69	108	260	P	H
		5459.16	41.24	-12.76	54	29.93	31.82	6.18	26.69	108	260	A	H
		5145.08	52.69	-21.31	74	41.31	32	6.08	26.7	100	226	P	V
		5087.1	42.27	-11.73	54	30.98	31.95	6.05	26.71	100	226	A	V
	*	5230	100.67	-	-	89.74	31.52	6.11	26.7	100	226	P	V
	*	5230	88.68	-	-	77.75	31.52	6.11	26.7	100	226	A	V
	5442.92	51.22	-22.78	74	39.98	31.77	6.16	26.69	100	226	P	V	
	5459.72	41.26	-12.74	54	29.95	31.82	6.18	26.69	100	226	A	V	
Remark	1. No other spurious found. 2. All results are PASS against Peak and Average limit line.												



Band 1 5150~5250MHz
WIFI 802.11ax HE40 (Harmonic @ 3m)

WIFI Ant. 1+2	Note	Frequency (MHz)	Level (dBμV/m)	Over Limit (dB)	Limit Line (dBμV/m)	Read Level (dBμV)	Antenna Factor (dB/m)	Path Loss (dB)	Preamp Factor (dB)	Ant Pos (cm)	Table Pos (deg)	Peak Avg. (P/A)	Pol. (H/V)	
802.11ax HE40 CH 38 5190MHz		10380	45.88	-22.32	68.2	53.09	39.82	9.92	56.95	100	0	P	H	
		15570	44.76	-29.24	74	50.14	38.58	12.66	56.62	100	0	P	H	
													H	
													H	
			10380	47.09	-21.11	68.2	54.3	39.82	9.92	56.95	100	0	P	V
			15570	44.8	-29.2	74	50.18	38.58	12.66	56.62	100	0	P	V
														V
802.11ax HE40 CH 46 5230MHz		10460	47.23	-20.97	68.2	54.23	39.96	9.96	56.92	100	0	P	H	
		15690	43.86	-30.14	74	49.48	38.13	12.72	56.47	100	0	P	H	
													H	
													H	
			10460	48.52	-19.68	68.2	55.52	39.96	9.96	56.92	100	0	P	V
			15690	43.91	-30.09	74	49.53	38.13	12.72	56.47	100	0	P	V
														V
Remark	1. No other spurious found.													
	2. All results are PASS against Peak and Average limit line.													



Band 1 5150~5250MHz
WIFI 802.11ax HE80 (Band Edge @ 3m)

WIFI Ant. 1+2	Note	Frequency (MHz)	Level (dBμV/m)	Over Limit (dB)	Limit Line (dBμV/m)	Read Level (dBμV)	Antenna Factor (dB/m)	Path Loss (dB)	Preamp Factor (dB)	Ant Pos (cm)	Table Pos (deg)	Peak Avg. (P/A)	Pol. (H/V)
802.11ax HE80 CH 42 5210MHz		5136.5	60.58	-13.42	74	49.2	32	6.08	26.7	102	246	P	H
		5149.76	47.71	-6.29	54	36.33	32	6.08	26.7	102	246	A	H
	*	5210	98.59	-	-	87.52	31.66	6.11	26.7	102	246	P	H
	*	5210	87.2	-	-	76.13	31.66	6.11	26.7	102	246	A	H
		5367.04	50.59	-23.41	74	39.7	31.47	6.12	26.7	102	246	P	H
		5458.32	41.42	-12.58	54	30.11	31.82	6.18	26.69	102	246	A	H
		5146.12	58.59	-15.41	74	47.21	32	6.08	26.7	100	232	P	V
		5108.16	43.03	-10.97	54	31.68	32	6.06	26.71	100	232	A	V
	*	5210	94.55	-	-	83.48	31.66	6.11	26.7	100	232	P	V
	*	5210	84.06	-	-	72.99	31.66	6.11	26.7	100	232	A	V
		5425.56	51.37	-22.63	74	40.21	31.7	6.15	26.69	100	232	P	V
	5459.72	41.44	-12.56	54	30.13	31.82	6.18	26.69	100	232	A	V	
Remark	1. No other spurious found. 2. All results are PASS against Peak and Average limit line.												



Band 1 5150~5250MHz

WIFI 802.11ax HE80 (Harmonic @ 3m)

WIFI Ant. 1+2	Note	Frequency (MHz)	Level (dBμV/m)	Over Limit (dB)	Limit Line (dBμV/m)	Read Level (dBμV)	Antenna Factor (dB/m)	Path Loss (dB)	Preamp Factor (dB)	Ant Pos (cm)	Table Pos (deg)	Peak Avg. (P/A)	Pol. (H/V)
802.11ax HE80		10420	46.47	-21.73	68.2	53.54	39.92	9.94	56.93	100	0	P	H
		15630	45.59	-28.41	74	51.12	38.31	12.7	56.54	100	0	P	H
													H
													H
CH 42 5210MHz		10420	46.46	-21.74	68.2	53.53	39.92	9.94	56.93	100	0	P	V
		15630	45.55	-28.45	74	51.08	38.31	12.7	56.54	100	0	P	V
													V
													V
Remark	1. No other spurious found. 2. All results are PASS against Peak and Average limit line.												



Emission below 1GHz

WIFI 802.11ax HE80 (LF @ 3m)

WIFI	Note	Frequency	Level	Over	Limit	Read	Antenna	Path	Preamp	Ant	Table	Peak	Pol.	
Ant.				Limit	Line	Level	Factor	Loss	Factor	Pos	Pos	Avg.		
1+2		(MHz)	(dBμV/m)	(dB)	(dBμV/m)	(dBμV)	(dB/m)	(dB)	(dB)	(cm)	(deg)	(P/A)	(H/V)	
802.11ax HE80 LF		167.74	33.72	-9.78	43.5	49.36	15.5	1.21	32.25	-	-	P	H	
		199.75	36.75	-6.75	43.5	53.22	14.6	1.36	32.31	-	-	P	H	
		233.7	39.28	-6.72	46	53.93	16.24	1.42	32.2	-	-	P	H	
		730.34	39.75	-6.25	46	41.87	27.31	2.43	31.73	100	0	P	H	
		800.18	37.69	-8.31	46	39.71	27.5	2.58	31.95	-	-	P	H	
		836.07	36.89	-9.11	46	37.71	28.44	2.73	31.83	-	-	P	H	
														H
														H
														H
														H
														H
														H
														H
														H
														H
														H
														H
														H
														H
			42.61	28.25	-11.75	40	41.98	18.03	0.52	32.28	-	-	P	V
		199.75	32.27	-11.23	43.5	48.74	14.6	1.24	32.31	-	-	P	V	
		233.7	34.51	-11.49	46	49.16	16.24	1.31	32.2	-	-	P	V	
		266.68	32.37	-13.63	46	43.79	19.3	1.38	32.1	-	-	P	V	
		800.18	39.7	-6.3	46	41.72	27.5	2.43	31.95	100	0	P	V	
		950.53	33.43	-12.57	46	31.25	30.51	2.66	30.99	-	-	P	V	
													V	
													V	
													V	
													V	
													V	
													V	
													V	
													V	
													V	
													V	
Remark	1. No other spurious found. 2. All results are PASS against limit line.													



Test Engineer :	Cookie Ku, Fu Chen, Troye Hsieh	Temperature :	18.7~25.6°C
		Relative Humidity :	40.2~69.4%

<CDD Mode>

Band 2 - 5250~5350MHz
WIFI 802.11a (Band Edge @ 3m)

WIFI	Note	Frequency	Level	Over	Limit	Read	Antenna	Path	Preamp	Ant	Table	Peak	Pol.
Ant.				Limit	Line	Level	Factor	Loss	Factor	Pos	Pos	Avg.	
1		(MHz)	(dBμV/m)	(dB)	(dBμV/m)	(dBμV)	(dB/m)	(dB)	(dB)	(cm)	(deg)	(P/A)	(H/V)
802.11a CH 52 5260MHz		5069.36	50.18	-23.82	74	41.48	31.62	9.95	32.87	200	317	P	H
		5103.36	40.56	-13.44	54	31.62	31.8	9.98	32.84	200	317	A	H
	*	5260	109.38	-	-	100.61	31.4	10.11	32.74	200	317	P	H
	*	5260	102.02	-	-	93.25	31.4	10.11	32.74	200	317	A	H
		5447.28	49.34	-24.66	74	40.05	31.69	10.22	32.62	200	317	P	H
		5459.76	39.43	-14.57	54	30.07	31.74	10.24	32.62	200	317	A	H
		5129.54	52.08	-21.92	74	43.1	31.8	10.01	32.83	100	20	P	V
		5098.6	40.54	-13.46	54	31.62	31.79	9.98	32.85	100	20	A	V
	*	5260	108.11	-	-	99.34	31.4	10.11	32.74	100	20	P	V
	*	5260	100.89	-	-	92.12	31.4	10.11	32.74	100	20	A	V
		5385.12	49.24	-24.76	74	40.24	31.51	10.15	32.66	100	20	P	V
		5458.8	39.36	-14.64	54	30	31.74	10.24	32.62	100	20	A	V
802.11a CH 60 5300MHz		5129.54	49.9	-24.1	74	40.92	31.8	10.01	32.83	182	295	P	H
		5143.48	40.78	-13.22	54	31.77	31.8	10.03	32.82	182	295	A	H
	*	5300	109.76	-	-	100.96	31.4	10.12	32.72	182	295	P	H
	*	5300	102.35	-	-	93.55	31.4	10.12	32.72	182	295	A	H
		5351.28	49.13	-24.87	74	40.37	31.31	10.14	32.69	182	295	P	H
		5350.08	41.21	-12.79	54	32.46	31.3	10.14	32.69	182	295	A	H
		5090.1	50.47	-23.53	74	41.61	31.74	9.97	32.85	113	28	P	V
		5098.94	40.74	-13.26	54	31.82	31.79	9.98	32.85	113	28	A	V
	*	5300	107.61	-	-	98.81	31.4	10.12	32.72	113	28	P	V
	*	5300	100.22	-	-	91.42	31.4	10.12	32.72	113	28	A	V
		5451.6	50.09	-23.91	74	40.77	31.71	10.23	32.62	113	28	P	V
		5350.08	40.5	-13.5	54	31.75	31.3	10.14	32.69	113	28	A	V



802.11a CH 64 5320MHz	*	5320	108.09	-	-	99.31	31.36	10.13	32.71	183	294	P	H
	*	5320	100.49	-	-	91.71	31.36	10.13	32.71	183	294	A	H
		5351.68	58.23	-15.77	74	49.46	31.31	10.14	32.68	183	294	P	H
		5350.08	49.62	-4.38	54	40.87	31.3	10.14	32.69	183	294	A	H
													H
													H
	*	5320	107.76	-	-	98.98	31.36	10.13	32.71	100	26	P	V
	*	5320	100.34	-	-	91.56	31.36	10.13	32.71	100	26	A	V
		5350.4	58.9	-15.1	74	50.15	31.3	10.14	32.69	100	26	P	V
		5350.08	47.9	-6.1	54	39.15	31.3	10.14	32.69	100	26	A	V
													V
													V
Remark	1. No other spurious found. 2. All results are PASS against Peak and Average limit line.												



Band 2 5250~5350MHz
WIFI 802.11a (Harmonic @ 3m)

WIFI Ant. 1	Note	Frequency (MHz)	Level (dBμV/m)	Over Limit (dB)	Limit Line (dBμV/m)	Read Level (dBμV)	Antenna Factor (dB/m)	Path Loss (dB)	Preamp Factor (dB)	Ant Pos (cm)	Table Pos (deg)	Peak Avg. (P/A)	Pol. (H/V)
802.11a CH 52 5260MHz		10520	47.87	-20.33	68.2	55.2	39.9	16.46	63.69	100	0	P	H
		15780	43.95	-30.05	74	48.17	37.22	20.57	62.01	100	0	P	H
													H
													H
		10520	47.25	-20.95	68.2	54.58	39.9	16.46	63.69	100	0	P	V
		15780	44.85	-29.15	74	49.07	37.22	20.57	62.01	100	0	P	V
													V
													V
802.11a CH 60 5300MHz		10600	45.62	-28.38	74	52.85	39.9	16.51	63.64	100	0	P	H
		15900	43.52	-30.48	74	48.14	36.9	20.54	62.06	100	0	P	H
													H
													H
		10600	46.62	-27.38	74	53.85	39.9	16.51	63.64	100	0	P	V
		15900	43.33	-30.67	74	47.95	36.9	20.54	62.06	100	0	P	V
													V
													V
802.11a CH 64 5320MHz		10640	45.71	-28.29	74	52.97	39.82	16.54	63.62	100	0	P	H
		15960	42.5	-31.5	74	47.27	36.78	20.53	62.08	100	0	P	H
													H
													H
		10640	46.65	-27.35	74	53.91	39.82	16.54	63.62	100	0	P	V
		15960	42.97	-31.03	74	47.74	36.78	20.53	62.08	100	0	P	V
													V
													V
Remark	1. No other spurious found. 2. All results are PASS against Peak and Average limit line.												



Band 2 5250~5350MHz
WIFI 802.11ac VHT20 (Band Edge @ 3m)

WIFI Ant. 1	Note	Frequency (MHz)	Level (dBμV/m)	Over Limit (dB)	Limit Line (dBμV/m)	Read Level (dBμV)	Antenna Factor (dB/m)	Path Loss (dB)	Preamp Factor (dB)	Ant Pos (cm)	Table Pos (deg)	Peak Avg. (P/A)	Pol. (H/V)
802.11ac VHT20 CH 52 5260MHz		5091.12	50.15	-23.85	74	41.28	31.75	9.97	32.85	283	318	P	H
		5098.26	40.59	-13.41	54	31.67	31.79	9.98	32.85	283	318	A	H
	*	5260	108.96	-	-	100.19	31.4	10.11	32.74	283	318	P	H
	*	5260	101.03	-	-	92.26	31.4	10.11	32.74	283	318	A	H
		5456.16	49.08	-24.92	74	39.74	31.72	10.24	32.62	283	318	P	H
		5458.32	39.41	-14.59	54	30.06	31.73	10.24	32.62	283	318	A	H
		5059.5	50.11	-23.89	74	41.48	31.56	9.94	32.87	220	343	P	V
		5100.98	40.55	-13.45	54	31.62	31.8	9.98	32.85	220	343	A	V
	*	5260	108	-	-	99.23	31.4	10.11	32.74	220	343	P	V
	*	5260	99.65	-	-	90.88	31.4	10.11	32.74	220	343	A	V
		5445.36	48.75	-25.25	74	39.46	31.69	10.22	32.62	220	343	P	V
		5458.56	39.3	-14.7	54	29.95	31.73	10.24	32.62	220	343	A	V
802.11ac VHT20 CH 60 5300MHz		5037.06	50.31	-23.69	74	41.84	31.45	9.91	32.89	325	313	P	H
		5100.3	40.74	-13.26	54	31.81	31.8	9.98	32.85	325	313	A	H
	*	5300	108.67	-	-	99.87	31.4	10.12	32.72	325	313	P	H
	*	5300	100.66	-	-	91.86	31.4	10.12	32.72	325	313	A	H
		5452.8	49.54	-24.46	74	40.22	31.71	10.23	32.62	325	313	P	H
		5350.32	40.22	-13.78	54	31.47	31.3	10.14	32.69	325	313	A	H
		5120.02	50.12	-23.88	74	41.15	31.8	10	32.83	100	15	P	V
		5094.52	40.71	-13.29	54	31.82	31.77	9.97	32.85	100	15	A	V
	*	5300	108.36	-	-	99.56	31.4	10.12	32.72	100	15	P	V
	*	5300	100.13	-	-	91.33	31.4	10.12	32.72	100	15	A	V
	5352.72	50.25	-23.75	74	41.47	31.32	10.14	32.68	100	15	P	V	
	5350.08	41.16	-12.84	54	32.41	31.3	10.14	32.69	100	15	A	V	



802.11ac VHT20 CH 64 5320MHz	*	5320	107.97	-	-	99.19	31.36	10.13	32.71	306	292	P	H
	*	5320	99.65	-	-	90.87	31.36	10.13	32.71	306	292	A	H
		5352.96	56.31	-17.69	74	47.53	31.32	10.14	32.68	306	292	P	H
		5350.08	48.66	-5.34	54	39.91	31.3	10.14	32.69	306	292	A	H
													H
													H
	*	5320	107.89	-	-	99.11	31.36	10.13	32.71	108	8	P	V
	*	5320	100	-	-	91.22	31.36	10.13	32.71	108	8	A	V
		5350.56	58.72	-15.28	74	49.97	31.3	10.14	32.69	108	8	P	V
		5350.08	48.64	-5.36	54	39.89	31.3	10.14	32.69	108	8	A	V
													V
													V
Remark	1. No other spurious found. 2. All results are PASS against Peak and Average limit line.												



Band 2 5250~5350MHz
WIFI 802.11ac VHT20 (Harmonic @ 3m)

WIFI Ant. 1	Note	Frequency (MHz)	Level (dBμV/m)	Over Limit (dB)	Limit Line (dBμV/m)	Read Level (dBμV)	Antenna Factor (dB/m)	Path Loss (dB)	Preamp Factor (dB)	Ant Pos (cm)	Table Pos (deg)	Peak Avg. (P/A)	Pol. (H/V)	
802.11ac VHT20 CH 52 5260MHz		10520	46.77	-21.43	68.2	54.1	39.9	16.46	63.69	100	0	P	H	
		15780	44.54	-29.46	74	48.76	37.22	20.57	62.01	100	0	P	H	
													H	
													H	
			10520	47.9	-20.3	68.2	55.23	39.9	16.46	63.69	100	0	P	V
			15780	44.21	-29.79	74	48.43	37.22	20.57	62.01	100	0	P	V
														V
802.11ac VHT20 CH 60 5300MHz		10600	46.67	-27.33	74	53.9	39.9	16.51	63.64	100	0	P	H	
		15900	42.94	-31.06	74	47.56	36.9	20.54	62.06	100	0	P	H	
													H	
													H	
			10600	45.54	-28.46	74	52.77	39.9	16.51	63.64	100	0	P	V
			15900	43.83	-30.17	74	48.45	36.9	20.54	62.06	100	0	P	V
														V
802.11ac VHT20 CH 64 5320MHz		10640	47.34	-26.66	74	54.6	39.82	16.54	63.62	100	0	P	H	
		15960	43.21	-30.79	74	47.98	36.78	20.53	62.08	100	0	P	H	
													H	
													H	
			10640	46.21	-27.79	74	53.47	39.82	16.54	63.62	100	0	P	V
			15960	42.8	-31.2	74	47.57	36.78	20.53	62.08	100	0	P	V
														V
Remark	1. No other spurious found.													
	2. All results are PASS against Peak and Average limit line.													



Band 2 5250~5350MHz
WIFI 802.11ac VHT40 (Band Edge @ 3m)

WIFI Ant. 1	Note	Frequency (MHz)	Level (dBμV/m)	Over Limit (dB)	Limit Line (dBμV/m)	Read Level (dBμV)	Antenna Factor (dB/m)	Path Loss (dB)	Preamp Factor (dB)	Ant Pos (cm)	Table Pos (deg)	Peak Avg. (P/A)	Pol. (H/V)
802.11ac VHT40 CH 54 5270MHz		5145.18	53.09	-20.91	74	44.08	31.8	10.03	32.82	297	322	P	H
		5149.94	44.55	-9.45	54	35.53	31.8	10.03	32.81	297	322	A	H
	*	5270	108.22	-	-	99.45	31.4	10.11	32.74	297	322	P	H
	*	5270	99.57	-	-	90.8	31.4	10.11	32.74	297	322	A	H
		5350.08	59.65	-14.35	74	50.9	31.3	10.14	32.69	297	322	P	H
		5350.08	50.7	-3.3	54	41.95	31.3	10.14	32.69	297	322	A	H
		5140.08	54.61	-19.39	74	45.61	31.8	10.02	32.82	100	350	P	V
		5149.6	45.09	-8.91	54	36.07	31.8	10.03	32.81	100	350	A	V
	*	5270	106.57	-	-	97.8	31.4	10.11	32.74	100	350	P	V
	*	5270	97.78	-	-	89.01	31.4	10.11	32.74	100	350	A	V
		5350.08	59.65	-14.35	74	50.9	31.3	10.14	32.69	100	350	P	V
		5350.08	50.61	-3.39	54	41.86	31.3	10.14	32.69	100	350	A	V
802.11ac VHT40 CH 62 5310MHz		5080.92	50.29	-23.71	74	41.5	31.69	9.96	32.86	393	311	P	H
		5092.82	40.52	-13.48	54	31.64	31.76	9.97	32.85	393	311	A	H
	*	5310	103.16	-	-	94.37	31.38	10.12	32.71	393	311	P	H
	*	5310	94.91	-	-	86.12	31.38	10.12	32.71	393	311	A	H
		5350.32	57.46	-16.54	74	48.71	31.3	10.14	32.69	393	311	P	H
		5350.08	47.11	-6.89	54	38.36	31.3	10.14	32.69	393	311	A	H
		5136	51.08	-22.92	74	42.08	31.8	10.02	32.82	103	0	P	V
		5091.46	40.49	-13.51	54	31.62	31.75	9.97	32.85	103	0	A	V
	*	5310	103.65	-	-	94.86	31.38	10.12	32.71	103	0	P	V
	*	5310	95.08	-	-	86.29	31.38	10.12	32.71	103	0	A	V
	5350.32	59.32	-14.68	74	50.57	31.3	10.14	32.69	103	0	P	V	
	5350.08	49.13	-4.87	54	40.38	31.3	10.14	32.69	103	0	A	V	
Remark	1. No other spurious found. 2. All results are PASS against Peak and Average limit line.												



Band 2 5250~5350MHz
WIFI 802.11ac VHT40 (Harmonic @ 3m)

WIFI Ant. 1	Note	Frequency (MHz)	Level (dBμV/m)	Over Limit (dB)	Limit Line (dBμV/m)	Read Level (dBμV)	Antenna Factor (dB/m)	Path Loss (dB)	Preamp Factor (dB)	Ant Pos (cm)	Table Pos (deg)	Peak Avg. (P/A)	Pol. (H/V)	
802.11ac VHT40 CH 54 5270MHz		10540	44.57	-23.63	68.2	51.88	39.9	16.47	63.68	100	0	P	H	
		15810	42.91	-31.09	74	47.2	37.17	20.56	62.02	100	0	P	H	
													H	
													H	
			10540	45.71	-22.49	68.2	53.02	39.9	16.47	63.68	100	0	P	V
			15810	43.87	-30.13	74	48.16	37.17	20.56	62.02	100	0	P	V
														V
802.11ac VHT40 CH 62 5310MHz		10620	44.59	-29.41	74	51.84	39.86	16.52	63.63	100	0	P	H	
		15930	42.52	-31.48	74	47.21	36.84	20.54	62.07	100	0	P	H	
													H	
													H	
			10620	44.57	-29.43	74	51.82	39.86	16.52	63.63	100	0	P	V
			15930	42.38	-31.62	74	47.07	36.84	20.54	62.07	100	0	P	V
														V
Remark	1. No other spurious found.													
	2. All results are PASS against Peak and Average limit line.													



Band 2 5250~5350MHz
WIFI 802.11ac VHT80 (Band Edge @ 3m)

WIFI Ant. 1	Note	Frequency (MHz)	Level (dBμV/m)	Over Limit (dB)	Limit Line (dBμV/m)	Read Level (dBμV)	Antenna Factor (dB/m)	Path Loss (dB)	Preamp Factor (dB)	Ant Pos (cm)	Table Pos (deg)	Peak Avg. (P/A)	Pol. (H/V)
802.11ac VHT80 CH 58 5290MHz		5029.7	50.98	-23.02	74	42.55	31.42	9.9	32.89	378	309	P	H
		5101.7	40.51	-13.49	54	31.57	31.8	9.98	32.84	378	309	A	H
	*	5290	100.31	-	-	91.51	31.4	10.12	32.72	378	309	P	H
	*	5290	91.87	-	-	83.07	31.4	10.12	32.72	378	309	A	H
		5351.04	58.89	-15.11	74	50.13	31.31	10.14	32.69	378	309	P	H
		5350.08	46.57	-7.43	54	37.82	31.3	10.14	32.69	378	309	A	H
		5045.9	50.98	-23.02	74	42.46	31.48	9.92	32.88	108	1	P	V
		5098.4	40.52	-13.48	54	31.6	31.79	9.98	32.85	108	1	A	V
	*	5290	99.54	-	-	90.74	31.4	10.12	32.72	108	1	P	V
	*	5290	91.13	-	-	82.33	31.4	10.12	32.72	108	1	A	V
		5359.68	61.88	-12.12	74	53.06	31.36	10.14	32.68	108	1	P	V
		5350.8	48.27	-5.73	54	39.52	31.3	10.14	32.69	108	1	A	V
Remark	1. No other spurious found. 2. All results are PASS against Peak and Average limit line.												



**Band 2 5250~5350MHz
WIFI 802.11ac VHT80 (Harmonic @ 3m)**

WIFI Ant. 1	Note	Frequency (MHz)	Level (dBμV/m)	Over Limit (dB)	Limit Line (dBμV/m)	Read Level (dBμV)	Antenna Factor (dB/m)	Path Loss (dB)	Preamp Factor (dB)	Ant Pos (cm)	Table Pos (deg)	Peak Avg. (P/A)	Pol. (H/V)	
802.11ac VHT80 CH 58 5290MHz		10580	42.71	-25.49	68.2	49.96	39.9	16.5	63.65	100	0	P	H	
		15870	43.25	-30.75	74	47.76	36.99	20.55	62.05	100	0	P	H	
													H	
													H	
			10580	42.64	-25.56	68.2	49.89	39.9	16.5	63.65	100	0	P	V
			15870	42.58	-31.42	74	47.09	36.99	20.55	62.05	100	0	P	V
														V
													V	
Remark	1. No other spurious found. 2. All results are PASS against Peak and Average limit line.													



Band 3 - 5470~5725MHz
WIFI 802.11a (Band Edge @ 3m)

WIFI	Note	Frequency	Level	Over	Limit	Read	Antenna	Path	Preamp	Ant	Table	Peak	Pol.	
Ant.				Limit	Line	Level	Factor	Loss	Factor	Pos	Pos	Avg.		
1		(MHz)	(dBμV/m)	(dB)	(dBμV/m)	(dBμV)	(dB/m)	(dB)	(dB)	(cm)	(deg)	(P/A)	(H/V)	
802.11a CH 100 5500MHz		5458	53.17	-20.83	74	43.82	31.73	10.24	32.62	266	312	P	H	
		5469.68	59.66	-8.54	68.2	50.23	31.78	10.26	32.61	266	312	P	H	
		5460	42.41	-11.59	54	33.05	31.74	10.24	32.62	266	312	A	H	
	*	5500	111.8	-	-	102.18	31.9	10.31	32.59	266	312	P	H	
	*	5500	104.18	-	-	94.56	31.9	10.31	32.59	266	312	A	H	
														H
			5458.8	52.51	-21.49	74	43.15	31.74	10.24	32.62	199	18	P	V
			5469.36	59.15	-9.05	68.2	49.72	31.78	10.26	32.61	199	18	P	V
			5460	42.2	-11.8	54	32.84	31.74	10.24	32.62	199	18	A	V
	*		5500	109.85	-	-	100.23	31.9	10.31	32.59	199	18	P	V
	*		5500	101.97	-	-	92.35	31.9	10.31	32.59	199	18	A	V
														V
802.11a CH 116 5580MHz		5444.8	50.14	-23.86	74	40.86	31.69	10.22	32.63	272	309	P	H	
		5469.52	48.42	-19.78	68.2	38.99	31.78	10.26	32.61	272	309	P	H	
		5428.72	40.12	-13.88	54	30.91	31.66	10.19	32.64	272	309	A	H	
	*	5580	113.98	-	-	104.26	31.86	10.43	32.57	272	309	P	H	
	*	5580	106.02	-	-	96.3	31.86	10.43	32.57	272	309	A	H	
			5740.43	51.15	-17.05	68.2	40.95	32.18	10.54	32.52	272	309	P	H
			5450.8	49.98	-24.02	74	40.67	31.7	10.23	32.62	208	18	P	V
			5461.84	49.4	-18.8	68.2	40.01	31.75	10.25	32.61	208	18	P	V
			5458.96	39.97	-14.03	54	30.61	31.74	10.24	32.62	208	18	A	V
	*		5580	109.5	-	-	99.78	31.86	10.43	32.57	208	18	P	V
	*		5580	101.95	-	-	92.23	31.86	10.43	32.57	208	18	A	V
			5726.255	50.65	-17.55	68.2	40.5	32.15	10.53	32.53	208	18	P	V



802.11a CH 140 5700MHz	*	5700	112.41	-	-	102.33	32.1	10.51	32.53	287	310	P	H
	*	5700	104.83	-	-	94.75	32.1	10.51	32.53	287	310	A	H
		5728.36	62.33	-5.87	68.2	52.17	32.16	10.53	32.53	287	310	P	H
													H
													H
													H
	*	5700	106.69	-	-	96.61	32.1	10.51	32.53	210	18	P	V
	*	5700	98.41	-	-	88.33	32.1	10.51	32.53	210	18	A	V
		5725.32	57.18	-11.02	68.2	47.03	32.15	10.53	32.53	210	18	P	V
													V
													V
													V
Remark	1. No other spurious found. 2. All results are PASS against Peak and Average limit line.												



Band 3 - 5470~5725MHz
WIFI 802.11a (Harmonic @ 3m)

WIFI Ant. 1	Note	Frequency (MHz)	Level (dBμV/m)	Over Limit (dB)	Limit Line (dBμV/m)	Read Level (dBμV)	Antenna Factor (dB/m)	Path Loss (dB)	Preamp Factor (dB)	Ant Pos (cm)	Table Pos (deg)	Peak Avg. (P/A)	Pol. (H/V)
802.11a CH 100 5500MHz		11000	45.49	-28.51	74	52.13	40	16.76	63.4	100	0	P	H
		16500	44.53	-23.67	68.2	47.24	38.4	21.19	62.3	100	0	P	H
													H
													H
		11000	44.44	-29.56	74	51.08	40	16.76	63.4	100	0	P	V
		16500	44.9	-23.3	68.2	47.61	38.4	21.19	62.3	100	0	P	V
													V
													V
802.11a CH 116 5580MHz		11160	46.45	-27.55	74	53.41	39.48	16.99	63.43	100	0	P	H
		16740	45.82	-22.38	68.2	47.09	39.38	21.51	62.16	100	0	P	H
													H
													H
		11160	46.1	-27.9	74	53.06	39.48	16.99	63.43	100	0	P	V
		16740	45.82	-22.38	68.2	47.09	39.38	21.51	62.16	100	0	P	V
													V
													V
802.11a CH 140 5700MHz		11400	44.44	-29.56	74	50.88	39.7	17.34	63.48	100	0	P	H
		17100	45.76	-22.44	68.2	45.97	39.7	21.95	61.86	100	0	P	H
													H
													H
		11400	44.97	-29.03	74	51.41	39.7	17.34	63.48	100	0	P	V
		17100	45.57	-22.63	68.2	45.78	39.7	21.95	61.86	100	0	P	V
													V
													V
Remark	1. No other spurious found. 2. All results are PASS against Peak and Average limit line.												



Band 3 - 5470~5725MHz
WIFI 802.11ac VHT20 (Band Edge @ 3m)

WIFI Ant. 1	Note	Frequency (MHz)	Level (dBμV/m)	Over Limit (dB)	Limit Line (dBμV/m)	Read Level (dBμV)	Antenna Factor (dB/m)	Path Loss (dB)	Preamp Factor (dB)	Ant Pos (cm)	Table Pos (deg)	Peak Avg. (P/A)	Pol. (H/V)	
802.11ac VHT20 CH 100 5500MHz		5455.12	49.66	-24.34	74	40.32	31.72	10.24	32.62	254	352	P	H	
		5468.72	60.35	-7.85	68.2	50.93	31.77	10.26	32.61	254	352	P	H	
		5460	41.46	-12.54	54	32.1	31.74	10.24	32.62	254	352	A	H	
	*	5500	109.9	-	-	100.28	31.9	10.31	32.59	254	352	P	H	
	*	5500	101.81	-	-	92.19	31.9	10.31	32.59	254	352	A	H	
														H
			5460.08	50.52	-17.68	68.2	41.16	31.74	10.24	32.62	212	15	P	V
			5469.36	60.69	-7.51	68.2	51.26	31.78	10.26	32.61	212	15	P	V
			5460	42.16	-11.84	54	32.8	31.74	10.24	32.62	212	15	A	V
	*		5506	108.53	-	-	98.92	31.89	10.31	32.59	212	15	P	V
	*		5506	100.88	-	-	91.27	31.89	10.31	32.59	212	15	A	V
													V	
802.11ac VHT20 CH 116 5580MHz		5439.76	51.48	-22.52	74	42.22	31.68	10.21	32.63	257	336	P	H	
		5461.12	48.66	-19.54	68.2	39.29	31.74	10.24	32.61	257	336	P	H	
		5457.52	39.8	-14.2	54	30.45	31.73	10.24	32.62	257	336	A	H	
	*	5580	111.33	-	-	101.61	31.86	10.43	32.57	257	336	P	H	
	*	5580	102.73	-	-	93.01	31.86	10.43	32.57	257	336	A	H	
			5725.625	50.86	-17.34	68.2	40.71	32.15	10.53	32.53	257	336	P	H
			5430.16	50.78	-23.22	74	41.55	31.66	10.2	32.63	207	17	P	V
			5462.32	48.68	-19.52	68.2	39.29	31.75	10.25	32.61	207	17	P	V
			5457.52	39.79	-14.21	54	30.44	31.73	10.24	32.62	207	17	A	V
	*		5580	109.25	-	-	99.53	31.86	10.43	32.57	207	17	P	V
	*		5580	101.35	-	-	91.63	31.86	10.43	32.57	207	17	A	V
		5748.935	50.39	-17.81	68.2	40.17	32.2	10.54	32.52	207	17	P	V	



802.11ac VHT20 CH 140 5700MHz	*	5700	109.21	-	-	99.13	32.1	10.51	32.53	263	335	P	H
	*	5700	100.96	-	-	90.88	32.1	10.51	32.53	263	335	A	H
		5726.92	64.98	-3.22	68.2	54.83	32.15	10.53	32.53	263	335	P	H
													H
													H
													H
	*	5700	107.36	-	-	97.28	32.1	10.51	32.53	200	18	P	V
	*	5700	99.24	-	-	89.16	32.1	10.51	32.53	200	18	A	V
		5725	63.61	-4.59	68.2	53.46	32.15	10.53	32.53	200	18	P	V
													V
													V
													V
Remark	1. No other spurious found. 2. All results are PASS against Peak and Average limit line.												



Band 3 - 5470~5725MHz
WIFI 802.11ac VHT20 (Harmonic @ 3m)

WIFI Ant. 1	Note	Frequency (MHz)	Level (dBμV/m)	Over Limit (dB)	Limit Line (dBμV/m)	Read Level (dBμV)	Antenna Factor (dB/m)	Path Loss (dB)	Preamp Factor (dB)	Ant Pos (cm)	Table Pos (deg)	Peak Avg. (P/A)	Pol. (H/V)	
802.11ac VHT20 CH 100 5500MHz		11000	44.92	-29.08	74	51.56	40	16.76	63.4	100	0	P	H	
		16500	45.18	-23.02	68.2	47.89	38.4	21.19	62.3	100	0	P	H	
													H	
													H	
			11000	45.08	-28.92	74	51.72	40	16.76	63.4	100	0	P	V
			16500	44.55	-23.65	68.2	47.26	38.4	21.19	62.3	100	0	P	V
														V
802.11ac VHT20 CH 116 5580MHz		11160	45.62	-28.38	74	52.58	39.48	16.99	63.43	100	0	P	H	
		16740	45.94	-22.26	68.2	47.21	39.38	21.51	62.16	100	0	P	H	
													H	
													H	
			11160	46.6	-27.4	74	53.56	39.48	16.99	63.43	100	0	P	V
			16740	45.33	-22.87	68.2	46.6	39.38	21.51	62.16	100	0	P	V
														V
802.11ac VHT20 CH 140 5700MHz		11400	44.76	-29.24	74	51.2	39.7	17.34	63.48	100	0	P	H	
		17100	45.9	-22.3	68.2	46.11	39.7	21.95	61.86	100	0	P	H	
													H	
													H	
			11400	44.33	-29.67	74	50.77	39.7	17.34	63.48	100	0	P	V
			17100	47.3	-20.9	68.2	47.51	39.7	21.95	61.86	100	0	P	V
														V
Remark	1. No other spurious found.													
	2. All results are PASS against Peak and Average limit line.													



**Band 3 - 5470~5725MHz
WIFI 802.11ac VHT40 (Band Edge @ 3m)**

WIFI Ant. 1	Note	Frequency (MHz)	Level (dBμV/m)	Over Limit (dB)	Limit Line (dBμV/m)	Read Level (dBμV)	Antenna Factor (dB/m)	Path Loss (dB)	Preamp Factor (dB)	Ant Pos (cm)	Table Pos (deg)	Peak Avg. (P/A)	Pol. (H/V)
802.11ac VHT40 CH 102 5510MHz		5457.76	57.14	-16.86	74	47.79	31.73	10.24	32.62	251	353	P	H
		5469.52	63.8	-4.4	68.2	54.37	31.78	10.26	32.61	251	353	P	H
		5459.92	48.45	-5.55	54	39.09	31.74	10.24	32.62	251	353	A	H
	*	5510	105.85	-	-	96.24	31.88	10.32	32.59	251	353	P	H
	*	5510	97.52	-	-	87.91	31.88	10.32	32.59	251	353	A	H
		5762.165	50.13	-18.07	68.2	39.88	32.22	10.55	32.52	251	353	P	H
		5459.2	60.28	-13.72	74	50.92	31.74	10.24	32.62	264	10	P	V
		5468.08	64.4	-3.8	68.2	54.98	31.77	10.26	32.61	264	10	P	V
		5459.92	50.58	-3.42	54	41.22	31.74	10.24	32.62	264	10	A	V
	*	5510	105.47	-	-	95.86	31.88	10.32	32.59	264	10	P	V
	*	5510	97.14	-	-	87.53	31.88	10.32	32.59	264	10	A	V
	5746.73	49.49	-18.71	68.2	39.28	32.19	10.54	32.52	264	10	P	V	
802.11ac VHT40 CH 110 5550MHz		5459.68	57.04	-16.96	74	47.68	31.74	10.24	32.62	243	353	P	H
		5467.36	60.97	-7.23	68.2	51.56	31.77	10.25	32.61	243	353	P	H
		5459.92	47.91	-6.09	54	38.55	31.74	10.24	32.62	243	353	A	H
	*	5550	109.75	-	-	100.15	31.8	10.38	32.58	243	353	P	H
	*	5550	101.04	-	-	91.44	31.8	10.38	32.58	243	353	A	H
		5752.085	51.09	-17.11	68.2	40.87	32.2	10.54	32.52	243	353	P	H
		5457.04	59.13	-14.87	74	49.78	31.73	10.24	32.62	222	20	P	V
		5465.68	61.62	-6.58	68.2	52.22	31.76	10.25	32.61	222	20	P	V
		5459.92	49.81	-4.19	54	40.45	31.74	10.24	32.62	222	20	A	V
	*	5550	107.83	-	-	98.23	31.8	10.38	32.58	222	20	P	V
	*	5550	98.87	-	-	89.27	31.8	10.38	32.58	222	20	A	V
	5746.73	49.88	-18.32	68.2	39.67	32.19	10.54	32.52	222	20	P	V	



802.11ac VHT40 CH 134 5670MHz		5449.05	50.28	-23.72	74	40.97	31.7	10.23	32.62	265	343	P	H
		5468.65	49.77	-18.43	68.2	40.35	31.77	10.26	32.61	265	343	P	H
		5459.9	40.1	-13.9	54	30.74	31.74	10.24	32.62	265	343	A	H
	*	5670	109.73	-	-	99.85	31.92	10.5	32.54	265	343	P	H
	*	5670	101.4	-	-	91.52	31.92	10.5	32.54	265	343	A	H
		5726.85	64.12	-4.08	68.2	53.97	32.15	10.53	32.53	265	343	P	H
		5372.4	50.45	-23.55	74	41.55	31.43	10.14	32.67	147	1	P	V
		5469	49.79	-18.41	68.2	40.36	31.78	10.26	32.61	147	1	P	V
		5459.9	39.94	-14.06	54	30.58	31.74	10.24	32.62	147	1	A	V
	*	5670	107.38	-	-	97.5	31.92	10.5	32.54	147	1	P	V
	*	5670	98.99	-	-	89.11	31.92	10.5	32.54	147	1	A	V
		5729.825	61.82	-6.38	68.2	51.66	32.16	10.53	32.53	147	1	P	V
Remark	1. No other spurious found. 2. All results are PASS against Peak and Average limit line.												



Band 3 - 5470~5725MHz
WIFI 802.11ac VHT40 (Harmonic @ 3m)

WIFI Ant. 1	Note	Frequency (MHz)	Level (dBμV/m)	Over Limit (dB)	Limit Line (dBμV/m)	Read Level (dBμV)	Antenna Factor (dB/m)	Path Loss (dB)	Preamp Factor (dB)	Ant Pos (cm)	Table Pos (deg)	Peak Avg. (P/A)	Pol. (H/V)	
802.11ac VHT40 CH 102 5510MHz		11020	44.84	-29.16	74	51.53	39.92	16.79	63.4	100	0	P	H	
		16530	44.41	-23.79	68.2	46.94	38.52	21.23	62.28	100	0	P	H	
													H	
													H	
			11020	44.71	-29.29	74	51.4	39.92	16.79	63.4	100	0	P	V
			16530	44.41	-23.79	68.2	46.94	38.52	21.23	62.28	100	0	P	V
														V
802.11ac VHT40 CH 110 5550MHz		11100	44.37	-29.63	74	51.28	39.6	16.91	63.42	100	0	P	H	
		16650	44.11	-24.09	68.2	45.98	38.95	21.39	62.21	100	0	P	H	
													H	
													H	
			11100	43.25	-30.75	74	50.16	39.6	16.91	63.42	100	0	P	V
			16650	44.28	-23.92	68.2	46.15	38.95	21.39	62.21	100	0	P	V
														V
802.11ac VHT40 CH 134 5670MHz		11340	46.06	-27.94	74	52.75	39.52	17.26	63.47	100	0	P	H	
		17010	45.9	-22.3	68.2	46.32	39.7	21.87	61.99	100	0	P	H	
													H	
													H	
			11340	46.24	-27.76	74	52.93	39.52	17.26	63.47	100	0	P	V
			17010	45.85	-22.35	68.2	46.27	39.7	21.87	61.99	100	0	P	V
														V
Remark	1. No other spurious found.													
	2. All results are PASS against Peak and Average limit line.													



Band 3 5470~5725MHz
WIFI 802.11ac VHT80 (Band Edge @ 3m)

WIFI Ant. 1	Note	Frequency (MHz)	Level (dBμV/m)	Over Limit (dB)	Limit Line (dBμV/m)	Read Level (dBμV)	Antenna Factor (dB/m)	Path Loss (dB)	Preamp Factor (dB)	Ant Pos (cm)	Table Pos (deg)	Peak Avg. (P/A)	Pol. (H/V)
802.11ac VHT80 CH 106 5530MHz		5453.44	60.33	-13.67	74	51.01	31.71	10.23	32.62	272	314	P	H
		5467.36	62.7	-5.5	68.2	53.29	31.77	10.25	32.61	272	314	P	H
		5459.92	48.92	-5.08	54	39.56	31.74	10.24	32.62	272	314	A	H
	*	5530	101.84	-	-	92.23	31.84	10.35	32.58	272	314	P	H
	*	5530	92.18	-	-	82.57	31.84	10.35	32.58	272	314	A	H
		5759.96	50.28	-17.92	68.2	40.03	32.22	10.55	32.52	272	314	P	H
		5457.76	62.82	-11.18	74	53.47	31.73	10.24	32.62	100	17	P	V
		5464.24	64.5	-3.7	68.2	55.1	31.76	10.25	32.61	100	17	P	V
		5459.92	48.5	-5.5	54	39.14	31.74	10.24	32.62	100	17	A	V
	*	5530	99.95	-	-	90.34	31.84	10.35	32.58	100	17	P	V
	*	5530	91.65	-	-	82.04	31.84	10.35	32.58	100	17	A	V
	5751.77	49.69	-18.51	68.2	39.47	32.2	10.54	32.52	100	17	P	V	
802.11ac VHT80 CH 122 5610MHz		5455.35	54.45	-19.55	74	45.11	31.72	10.24	32.62	252	337	P	H
		5464.45	57.53	-10.67	68.2	48.13	31.76	10.25	32.61	252	337	P	H
		5459.9	45.3	-8.7	54	35.94	31.74	10.24	32.62	252	337	A	H
	*	5610	105.97	-	-	96.18	31.88	10.47	32.56	252	337	P	H
	*	5610	96.95	-	-	87.16	31.88	10.47	32.56	252	337	A	H
		5725.8	61.46	-6.74	68.2	51.31	32.15	10.53	32.53	252	337	P	H
		5456.05	58.45	-15.55	74	49.11	31.72	10.24	32.62	198	21	P	V
		5466.9	60.05	-8.15	68.2	50.64	31.77	10.25	32.61	198	21	P	V
		5459.9	48.73	-5.27	54	39.37	31.74	10.24	32.62	198	21	A	V
	*	5610	102.88	-	-	93.09	31.88	10.47	32.56	198	21	P	V
	*	5610	94.21	-	-	84.42	31.88	10.47	32.56	198	21	A	V
	5729.125	58.68	-9.52	68.2	48.52	32.16	10.53	32.53	198	21	P	V	
Remark	1. No other spurious found. 2. All results are PASS against Peak and Average limit line.												



Band 3 5470~5725MHz
WIFI 802.11ac VHT80 (Harmonic @ 3m)

WIFI Ant. 1	Note	Frequency (MHz)	Level (dBμV/m)	Over Limit (dB)	Limit Line (dBμV/m)	Read Level (dBμV)	Antenna Factor (dB/m)	Path Loss (dB)	Preamp Factor (dB)	Ant Pos (cm)	Table Pos (deg)	Peak Avg. (P/A)	Pol. (H/V)	
802.11ac VHT80 CH 106 5530MHz		11060	45.41	-28.59	74	52.21	39.76	16.85	63.41	100	0	P	H	
		16590	44.42	-23.78	68.2	46.6	38.76	21.31	62.25	100	0	P	H	
													H	
													H	
			11060	44.53	-29.47	74	51.33	39.76	16.85	63.41	100	0	P	V
			16590	44.33	-23.87	68.2	46.51	38.76	21.31	62.25	100	0	P	V
														V
802.11ac VHT80 CH 122 5610MHz		11220	44.88	-29.12	74	51.84	39.4	17.08	63.44	100	0	P	H	
		16830	45.86	-22.34	68.2	46.5	39.83	21.63	62.1	100	0	P	H	
													H	
													H	
			11220	44.92	-29.08	74	51.88	39.4	17.08	63.44	100	0	P	V
			16830	45.2	-23	68.2	45.84	39.83	21.63	62.1	100	0	P	V
														V
Remark	1. No other spurious found.													
	2. All results are PASS against Peak and Average limit line.													



Band 2 - 5250~5350MHz

WIFI 802.11ax HE20 (Full RU) (Band Edge @ 3m)

WIFI	Note	Frequency	Level	Over	Limit	Read	Antenna	Path	Preamp	Ant	Table	Peak	Pol.
Ant.				Limit	Line	Level	Factor	Loss	Factor	Pos	Pos	Avg.	
1+2		(MHz)	(dBμV/m)	(dB)	(dBμV/m)	(dBμV)	(dB/m)	(dB)	(dB)	(cm)	(deg)	(P/A)	(H/V)
802.11ax HE20 (Full RU) CH 52 5260MHz		5036.04	51.11	-22.89	74	42.65	31.44	9.91	32.89	219	16	P	H
		5098.26	40.6	-13.4	54	31.68	31.79	9.98	32.85	219	16	A	H
	*	5260	111.82	-	-	103.05	31.4	10.11	32.74	219	16	P	H
	*	5260	101.57	-	-	92.8	31.4	10.11	32.74	219	16	A	H
		5398.32	49.7	-24.3	74	40.62	31.59	10.15	32.66	219	16	P	H
		5459.52	39.49	-14.51	54	30.13	31.74	10.24	32.62	219	16	A	H
		5075.48	50.87	-23.13	74	42.13	31.65	9.95	32.86	353	338	P	V
		5097.24	40.61	-13.39	54	31.7	31.78	9.98	32.85	353	338	A	V
	*	5260	103.91	-	-	95.14	31.4	10.11	32.74	353	338	P	V
	*	5260	93.24	-	-	84.47	31.4	10.11	32.74	353	338	A	V
		5399.52	50.19	-23.81	74	41.09	31.6	10.15	32.65	353	338	P	V
		5457.12	39.61	-14.39	54	30.26	31.73	10.24	32.62	353	338	A	V
802.11ax HE20 (Full RU) 5300MHz		5136.34	50.9	-23.1	74	41.9	31.8	10.02	32.82	242	18	P	H
		5096.9	40.56	-13.44	54	31.65	31.78	9.98	32.85	242	18	A	H
	*	5300	112.85	-	-	104.05	31.4	10.12	32.72	242	18	P	H
	*	5300	104.62	-	-	95.82	31.4	10.12	32.72	242	18	A	H
		5353.44	53.87	-20.13	74	45.09	31.32	10.14	32.68	242	18	P	H
		5350.08	43.96	-10.04	54	35.21	31.3	10.14	32.69	242	18	A	H
		5107.1	50.38	-23.62	74	41.43	31.8	9.99	32.84	368	344	P	V
		5095.2	40.59	-13.41	54	31.7	31.77	9.97	32.85	368	344	A	V
	*	5300	107.25	-	-	98.45	31.4	10.12	32.72	368	344	P	V
	*	5300	97.32	-	-	88.52	31.4	10.12	32.72	368	344	A	V
		5356.08	50.07	-23.93	74	41.27	31.34	10.14	32.68	368	344	P	V
		5460	39.48	-14.52	54	30.12	31.74	10.24	32.62	368	344	A	V



802.11ax HE20 (Full RU) CH 64 5320MHz	*	5320	110.09	-	-	101.31	31.36	10.13	32.71	267	14	P	H
	*	5320	100.21	-	-	91.43	31.36	10.13	32.71	267	14	A	H
		5350.88	60.56	-13.44	74	51.8	31.31	10.14	32.69	267	14	P	H
		5350.08	48.72	-5.28	54	39.97	31.3	10.14	32.69	267	14	A	H
													H
													H
	*	5320	103.84	-	-	95.06	31.36	10.13	32.71	364	348	P	V
	*	5320	94.29	-	-	85.51	31.36	10.13	32.71	364	348	A	V
		5350.56	51.63	-22.37	74	42.88	31.3	10.14	32.69	364	348	P	V
		5350.08	40.88	-13.12	54	32.13	31.3	10.14	32.69	364	348	A	V
													V
													V
Remark	1. No other spurious found. 2. All results are PASS against Peak and Average limit line.												



Band 2 5250~5350MHz
WIFI 802.11ax HE20 (Full RU) (Harmonic @ 3m)

WIFI Ant. 1+2	Note	Frequency (MHz)	Level (dBμV/m)	Over Limit (dB)	Limit Line (dBμV/m)	Read Level (dBμV)	Antenna Factor (dB/m)	Path Loss (dB)	Preamp Factor (dB)	Ant Pos (cm)	Table Pos (deg)	Peak Avg. (P/A)	Pol. (H/V)	
802.11ax HE20 (Full RU) CH 52 5260MHz		10520	46.59	-21.61	68.2	53.92	39.9	16.46	63.69	100	0	P	H	
		15780	43.32	-30.68	74	47.54	37.22	20.57	62.01	100	0	P	H	
													H	
													H	
			10520	47.18	-21.02	68.2	54.51	39.9	16.46	63.69	100	0	P	V
			15780	43.11	-30.89	74	47.33	37.22	20.57	62.01	100	0	P	V
														V
802.11ax HE20 (Full RU) CH 60 5300MHz		10600	44.89	-29.11	74	52.12	39.9	16.51	63.64	100	0	P	H	
		15900	42.65	-31.35	74	47.27	36.9	20.54	62.06	100	0	P	H	
													H	
													H	
			10600	44.73	-29.27	74	51.96	39.9	16.51	63.64	100	0	P	V
			15900	42.05	-31.95	74	46.67	36.9	20.54	62.06	100	0	P	V
														V
802.11ax HE20 (Full RU) CH 64 5320MHz		10640	45.22	-28.78	74	52.48	39.82	16.54	63.62	100	0	P	H	
		15960	42.81	-31.19	74	47.58	36.78	20.53	62.08	100	0	P	H	
													H	
													H	
			10640	44.83	-29.17	74	52.09	39.82	16.54	63.62	100	0	P	V
			15960	42.68	-31.32	74	47.45	36.78	20.53	62.08	100	0	P	V
														V
Remark	1. No other spurious found.													
	2. All results are PASS against Peak and Average limit line.													



Band 2 5250~5350MHz

WIFI 802.11ax HE40 (Full RU) (Band Edge @ 3m)

WIFI Ant. 1+2	Note	Frequency (MHz)	Level (dBμV/m)	Over Limit (dB)	Limit Line (dBμV/m)	Read Level (dBμV)	Antenna Factor (dB/m)	Path Loss (dB)	Preamp Factor (dB)	Ant Pos (cm)	Table Pos (deg)	Peak Avg. (P/A)	Pol. (H/V)
802.11ax HE40 (Full RU) CH 54 5270MHz		5147.56	51.89	-22.11	74	42.88	31.8	10.03	32.82	254	31	P	H
		5149.94	41.82	-12.18	54	32.8	31.8	10.03	32.81	254	31	A	H
	*	5270	109.99	-	-	101.22	31.4	10.11	32.74	254	31	P	H
	*	5270	100.84	-	-	92.07	31.4	10.11	32.74	254	31	A	H
		5351.52	59.62	-14.38	74	50.86	31.31	10.14	32.69	254	31	P	H
		5350.08	50.14	-3.86	54	41.39	31.3	10.14	32.69	254	31	A	H
		5125.12	50.91	-23.09	74	41.93	31.8	10.01	32.83	256	297	P	V
		5149.26	40.54	-13.46	54	31.52	31.8	10.03	32.81	256	297	A	V
	*	5270	103.8	-	-	95.03	31.4	10.11	32.74	256	297	P	V
	*	5270	93.86	-	-	85.09	31.4	10.11	32.74	256	297	A	V
		5356.8	50.57	-23.43	74	41.77	31.34	10.14	32.68	256	297	P	V
		5350.08	40.64	-13.36	54	31.89	31.3	10.14	32.69	256	297	A	V
802.11ax HE40 (Full RU) CH 62 5310MHz		5075.48	50.34	-23.66	74	41.6	31.65	9.95	32.86	103	14	P	H
		5098.94	40.33	-13.67	54	31.41	31.79	9.98	32.85	103	14	A	H
	*	5310	107.89	-	-	99.1	31.38	10.12	32.71	103	14	P	H
	*	5310	97.77	-	-	88.98	31.38	10.12	32.71	103	14	A	H
		5350.56	60.74	-13.26	74	51.99	31.3	10.14	32.69	103	14	P	H
		5350.08	48.92	-5.08	54	40.17	31.3	10.14	32.69	103	14	A	H
		5072.76	50.75	-23.25	74	42.02	31.64	9.95	32.86	117	22	P	V
		5099.62	40.29	-13.71	54	31.36	31.8	9.98	32.85	117	22	A	V
	*	5310	102.34	-	-	93.55	31.38	10.12	32.71	117	22	P	V
	*	5310	93.51	-	-	84.72	31.38	10.12	32.71	117	22	A	V
		5350.32	56.68	-17.32	74	47.93	31.3	10.14	32.69	117	22	P	V
		5350.08	45.41	-8.59	54	36.66	31.3	10.14	32.69	117	22	A	V
Remark	<ol style="list-style-type: none"> No other spurious found. All results are PASS against Peak and Average limit line. 												



**Band 2 5250~5350MHz
WIFI 802.11ax HE40 (Full RU) (Harmonic @ 3m)**

WIFI Ant. 1+2	Note	Frequency (MHz)	Level (dBμV/m)	Over Limit (dB)	Limit Line (dBμV/m)	Read Level (dBμV)	Antenna Factor (dB/m)	Path Loss (dB)	Preamp Factor (dB)	Ant Pos (cm)	Table Pos (deg)	Peak Avg. (P/A)	Pol. (H/V)	
802.11ax HE40 (Full RU) CH 54 5270MHz		10540	45.97	-22.23	68.2	53.28	39.9	16.47	63.68	100	0	P	H	
		15810	43.01	-30.99	74	47.3	37.17	20.56	62.02	100	0	P	H	
													H	
													H	
			10540	45.47	-22.73	68.2	52.78	39.9	16.47	63.68	100	0	P	V
			15810	43.41	-30.59	74	47.7	37.17	20.56	62.02	100	0	P	V
														V
802.11ax HE40 (Full RU) CH 62 5310MHz		10620	48.05	-25.95	74	55.3	39.86	16.52	63.63	100	0	P	H	
		15930	43.59	-30.41	74	48.28	36.84	20.54	62.07	100	0	P	H	
													H	
													H	
			10620	45.38	-28.62	74	52.63	39.86	16.52	63.63	100	0	P	V
			15930	42.59	-31.41	74	47.28	36.84	20.54	62.07	100	0	P	V
														V
Remark	1. No other spurious found.													
	2. All results are PASS against Peak and Average limit line.													



Band 2 5250~5350MHz

WIFI 802.11ax HE80 (Full RU) (Band Edge @ 3m)

WIFI Ant. 1+2	Note	Frequency (MHz)	Level (dBμV/m)	Over Limit (dB)	Limit Line (dBμV/m)	Read Level (dBμV)	Antenna Factor (dB/m)	Path Loss (dB)	Preamp Factor (dB)	Ant Pos (cm)	Table Pos (deg)	Peak Avg. (P/A)	Pol. (H/V)
802.11ax HE80 (Full RU) CH 58 5290MHz		5101.4	50.85	-23.15	74	41.92	31.8	9.98	32.85	275	29	P	H
		5098.4	40.18	-13.82	54	31.26	31.79	9.98	32.85	275	29	A	H
	*	5290	102.44	-	-	93.64	31.4	10.12	32.72	275	29	P	H
	*	5290	94.38	-	-	85.58	31.4	10.12	32.72	275	29	A	H
		5351.76	62.8	-11.2	74	54.03	31.31	10.14	32.68	275	29	P	H
		5350.08	50.56	-3.44	54	41.81	31.3	10.14	32.69	275	29	A	H
		5083.4	51	-23	74	42.2	31.7	9.96	32.86	124	1	P	V
		5102.6	40.16	-13.84	54	31.22	31.8	9.98	32.84	124	1	A	V
	*	5290	96.34	-	-	87.54	31.4	10.12	32.72	124	1	P	V
	*	5290	88.67	-	-	79.87	31.4	10.12	32.72	124	1	A	V
		5352.72	56.34	-17.66	74	47.56	31.32	10.14	32.68	124	1	P	V
		5350.32	45.12	-8.88	54	36.37	31.3	10.14	32.69	124	1	A	V
Remark	1. No other spurious found. 2. All results are PASS against Peak and Average limit line.												



Band 2 5250~5350MHz

WIFI 802.11ax HE80 (Full RU) (Harmonic @ 3m)

WIFI Ant. 1+2	Note	Frequency (MHz)	Level (dBμV/m)	Over Limit (dB)	Limit Line (dBμV/m)	Read Level (dBμV)	Antenna Factor (dB/m)	Path Loss (dB)	Preamp Factor (dB)	Ant Pos (cm)	Table Pos (deg)	Peak Avg. (P/A)	Pol. (H/V)	
802.11ax HE80 (Full RU) CH 58 5290MHz		10580	45.87	-22.33	68.2	53.12	39.9	16.5	63.65	100	0	P	H	
		15870	44.65	-29.35	74	49.16	36.99	20.55	62.05	100	0	P	H	
													H	
													H	
			10580	44.99	-23.21	68.2	52.24	39.9	16.5	63.65	100	0	P	V
			15870	43.63	-30.37	74	48.14	36.99	20.55	62.05	100	0	P	V
														V
														V
Remark	1. No other spurious found. 2. All results are PASS against Peak and Average limit line.													



Band 2 5250~5350MHz

WIFI 802.11ax HE20 (Partial 26 8RU) (Band Edge @ 3m)

WIFI Ant. 1+2	Note	Frequency (MHz)	Level (dBμV/m)	Over Limit (dB)	Limit Line (dBμV/m)	Read Level (dBμV)	Antenna Factor (dB/m)	Path Loss (dB)	Preamp Factor (dB)	Ant Pos (cm)	Table Pos (deg)	Peak Avg. (P/A)	Pol. (H/V)
802.11ax HE20 CH 64 5320MHz	*	5320	109.96	-	-	101.18	31.36	10.13	32.71	100	60	P	H
	*	5320	102.82	-	-	94.04	31.36	10.13	32.71	100	60	A	H
		5457.12	49.11	-24.89	74	39.76	31.73	10.24	32.62	100	60	P	H
		5459.68	39.58	-14.42	54	30.22	31.74	10.24	32.62	100	60	A	H
													H
													H
	*	5320	102.89	-	-	94.11	31.36	10.13	32.71	240	24	P	V
	*	5320	95.57	-	-	86.79	31.36	10.13	32.71	240	24	A	V
		5397.28	48.08	-25.92	74	39.01	31.58	10.15	32.66	240	24	P	V
		5460	39.49	-14.51	54	30.13	31.74	10.24	32.62	240	24	A	V
													V
													V
Remark	<ol style="list-style-type: none"> No other spurious found. All results are PASS against Peak and Average limit line. 												



Band 2 5250~5350MHz

WIFI 802.11ax HE20 (Partial 52 40RU) (Band Edge @ 3m)

WIFI Ant. 1+2	Note	Frequency (MHz)	Level (dBμV/m)	Over Limit (dB)	Limit Line (dBμV/m)	Read Level (dBμV)	Antenna Factor (dB/m)	Path Loss (dB)	Preamp Factor (dB)	Ant Pos (cm)	Table Pos (deg)	Peak Avg. (P/A)	Pol. (H/V)
802.11ax HE20 CH 64 5320MHz	*	5320	112.09	-	-	103.31	31.36	10.13	32.71	100	56	P	H
	*	5320	103.8	-	-	95.02	31.36	10.13	32.71	100	56	A	H
		5409.44	49.3	-24.7	74	40.17	31.62	10.16	32.65	100	56	P	H
		5458.56	39.62	-14.38	54	30.27	31.73	10.24	32.62	100	56	A	H
													H
													H
	*	5320	108.88	-	-	100.1	31.36	10.13	32.71	103	22	P	V
	*	5320	99.99	-	-	91.21	31.36	10.13	32.71	103	22	A	V
		5445.12	49.71	-24.29	74	40.43	31.69	10.22	32.63	103	22	P	V
		5460	39.56	-14.44	54	30.2	31.74	10.24	32.62	103	22	A	V
													V
													V
Remark	3. No other spurious found. 4. All results are PASS against Peak and Average limit line.												



Band 2 5250~5350MHz

WIFI 802.11ax HE20 (Partial 106 54RU) (Band Edge @ 3m)

WIFI Ant. 1+2	Note	Frequency (MHz)	Level (dBμV/m)	Over Limit (dB)	Limit Line (dBμV/m)	Read Level (dBμV)	Antenna Factor (dB/m)	Path Loss (dB)	Preamp Factor (dB)	Ant Pos (cm)	Table Pos (deg)	Peak Avg. (P/A)	Pol. (H/V)
802.11ax HE20 CH 64 5320MHz	*	5320	112.57	-	-	103.79	31.36	10.13	32.71	267	21	P	H
	*	5320	103.96	-	-	95.18	31.36	10.13	32.71	267	21	A	H
		5409.92	49.06	-24.94	74	39.92	31.62	10.17	32.65	267	21	P	H
		5459.2	39.86	-14.14	54	30.5	31.74	10.24	32.62	267	21	A	H
													H
													H
	*	5320	107.55	-	-	98.77	31.36	10.13	32.71	143	15	P	V
	*	5320	98.7	-	-	89.92	31.36	10.13	32.71	143	15	A	V
		5424.48	49.66	-24.34	74	40.46	31.65	10.19	32.64	143	15	P	V
		5457.76	39.76	-14.24	54	30.41	31.73	10.24	32.62	143	15	A	V
													V
													V
Remark	5. No other spurious found. 6. All results are PASS against Peak and Average limit line.												



Band 2 5250~5350MHz

WIFI 802.11ax HE40 (Partial 242 62RU) (Band Edge @ 3m)

WIFI Ant. 1+2	Note	Frequency (MHz)	Level (dBμV/m)	Over Limit (dB)	Limit Line (dBμV/m)	Read Level (dBμV)	Antenna Factor (dB/m)	Path Loss (dB)	Preamp Factor (dB)	Ant Pos (cm)	Table Pos (deg)	Peak Avg. (P/A)	Pol. (H/V)
802.11ax HE40 CH 54 5270MHz		5138.04	54.65	-19.35	74	45.65	31.8	10.02	32.82	253	16	P	H
		5139.74	40.68	-13.32	54	31.68	31.8	10.02	32.82	253	16	A	H
	*	5270	113.45	-	-	104.68	31.4	10.11	32.74	253	16	P	H
	*	5270	104.15	-	-	95.38	31.4	10.11	32.74	253	16	A	H
		5354.4	64.44	-9.56	74	55.65	31.33	10.14	32.68	253	16	P	H
		5351.28	45.38	-8.62	54	36.62	31.31	10.14	32.69	253	16	A	H
		5120.7	51.33	-22.67	74	42.36	31.8	10	32.83	263	31	P	V
		5100.98	40.46	-13.54	54	31.53	31.8	9.98	32.85	263	31	A	V
	*	5270	108.42	-	-	99.65	31.4	10.11	32.74	263	31	P	V
	*	5270	99.29	-	-	90.52	31.4	10.11	32.74	263	31	A	V
		5354.16	56.79	-17.21	74	48.01	31.32	10.14	32.68	263	31	P	V
		5351.04	40.22	-13.78	54	31.46	31.31	10.14	32.69	263	31	A	V
802.11ax HE40 CH 62 5310MHz		5144.16	52.22	-21.78	74	43.21	31.8	10.03	32.82	264	20	P	H
		5095.88	40.4	-13.6	54	31.49	31.78	9.98	32.85	264	20	A	H
	*	5310	112.41	-	-	103.62	31.38	10.12	32.71	264	20	P	H
	*	5310	103.35	-	-	94.56	31.38	10.12	32.71	264	20	A	H
		5353.2	62.65	-11.35	74	53.87	31.32	10.14	32.68	264	20	P	H
		5350.08	48.77	-5.23	54	40.02	31.3	10.14	32.69	264	20	A	H
		5144.84	51.89	-22.11	74	42.88	31.8	10.03	32.82	228	20	P	V
		5094.52	40.44	-13.56	54	31.55	31.77	9.97	32.85	228	20	A	V
	*	5310	106.46	-	-	97.67	31.38	10.12	32.71	228	20	P	V
	*	5310	96.82	-	-	88.03	31.38	10.12	32.71	228	20	A	V
	5350.32	59.89	-14.11	74	51.14	31.3	10.14	32.69	228	20	P	V	
	5350.08	45.32	-8.68	54	36.57	31.3	10.14	32.69	228	20	A	V	
Remark	<p>3. No other spurious found.</p> <p>4. All results are PASS against Peak and Average limit line.</p>												



Band 2 5250~5350MHz

WIFI 802.11ax HE80 (Partial 484 66RU) (Band Edge @ 3m)

WIFI Ant. 1+2	Note	Frequency (MHz)	Level (dBμV/m)	Over Limit (dB)	Limit Line (dBμV/m)	Read Level (dBμV)	Antenna Factor (dB/m)	Path Loss (dB)	Preamp Factor (dB)	Ant Pos (cm)	Table Pos (deg)	Peak Avg. (P/A)	Pol. (H/V)
802.11ax HE80 CH 58 5290MHz		5071.1	50.9	-23.1	74	42.18	31.63	9.95	32.86	125	11	P	H
		5095.4	40.54	-13.46	54	31.65	31.77	9.97	32.85	125	11	A	H
	*	5290	106.67	-	-	97.87	31.4	10.12	32.72	125	11	P	H
	*	5290	96.29	-	-	87.49	31.4	10.12	32.72	125	11	A	H
		5367.36	59.72	-14.28	74	50.85	31.4	10.14	32.67	125	11	P	H
		5350.08	46.75	-7.25	54	38	31.3	10.14	32.69	125	11	A	H
		5111.9	51.31	-22.69	74	42.36	31.8	9.99	32.84	216	26	P	V
		5092.4	40.54	-13.46	54	31.67	31.75	9.97	32.85	216	26	A	V
	*	5290	101.19	-	-	92.39	31.4	10.12	32.72	216	26	P	V
	*	5290	90.6	-	-	81.8	31.4	10.12	32.72	216	26	A	V
		5364	54.41	-19.59	74	45.57	31.38	10.14	32.68	216	26	P	V
		5350.08	42.05	-11.95	54	33.3	31.3	10.14	32.69	216	26	A	V
Remark	3. No other spurious found. 4. All results are PASS against Peak and Average limit line.												



Band 3 - 5470~5725MHz

WIFI 802.11ax HE20 (Full RU) (Band Edge @ 3m)

WIFI Ant. 1+2	Note	Frequency (MHz)	Level (dBμV/m)	Over Limit (dB)	Limit Line (dBμV/m)	Read Level (dBμV)	Antenna Factor (dB/m)	Path Loss (dB)	Preamp Factor (dB)	Ant Pos (cm)	Table Pos (deg)	Peak Avg. (P/A)	Pol. (H/V)	
802.11ax HE20 (Full RU) CH 100 5500MHz		5459.44	53.93	-20.07	74	44.57	31.74	10.24	32.62	297	27	P	H	
		5466.8	64.19	-4.01	68.2	54.78	31.77	10.25	32.61	297	27	P	H	
		5460	42.96	-11.04	54	33.6	31.74	10.24	32.62	297	27	A	H	
	*	5500	113.01	-	-	103.39	31.9	10.31	32.59	297	27	P	H	
	*	5500	102.41	-	-	92.79	31.9	10.31	32.59	297	27	A	H	
														H
			5456.72	53.42	-20.58	74	44.07	31.73	10.24	32.62	273	24	P	V
			5469.84	62.46	-5.74	68.2	53.03	31.78	10.26	32.61	273	24	P	V
			5460	42.91	-11.09	54	33.55	31.74	10.24	32.62	273	24	A	V
	*		5500	112.99	-	-	103.37	31.9	10.31	32.59	273	24	P	V
	*		5500	102.44	-	-	92.82	31.9	10.31	32.59	273	24	A	V
														V
802.11ax HE20 (Full RU) CH 116 5580MHz		5362	50.27	-23.73	74	41.44	31.37	10.14	32.68	289	22	P	H	
		5469.76	50.86	-17.34	68.2	41.43	31.78	10.26	32.61	289	22	P	H	
		5459.92	39.74	-14.26	54	30.38	31.74	10.24	32.62	289	22	A	H	
	*	5580	113.2	-	-	103.48	31.86	10.43	32.57	289	22	P	H	
	*	5580	102.86	-	-	93.14	31.86	10.43	32.57	289	22	A	H	
			5759.96	51.2	-17	68.2	40.95	32.22	10.55	32.52	289	22	P	H
			5434.24	50.87	-23.13	74	41.63	31.67	10.2	32.63	279	20	P	V
			5460.88	50.34	-17.86	68.2	40.98	31.74	10.24	32.62	279	20	P	V
			5458.96	39.78	-14.22	54	30.42	31.74	10.24	32.62	279	20	A	V
	*		5580	114.65	-	-	104.93	31.86	10.43	32.57	279	20	P	V
	*		5580	103.93	-	-	94.21	31.86	10.43	32.57	279	20	A	V
			5735.39	50.82	-17.38	68.2	40.64	32.17	10.53	32.52	279	20	P	V



802.11ax HE20 (Full RU) CH 140 5700MHz	*	5700	107.75	-	-	97.67	32.1	10.51	32.53	274	16	P	H
	*	5700	97.21	-	-	87.13	32.1	10.51	32.53	274	16	A	H
		5727.16	56.83	-11.37	68.2	46.68	32.15	10.53	32.53	274	16	P	H
													H
													H
													H
	*	5700	112.1	-	-	102.02	32.1	10.51	32.53	281	14	P	V
	*	5700	101.37	-	-	91.29	32.1	10.51	32.53	281	14	A	V
		5726.28	64.18	-4.02	68.2	54.03	32.15	10.53	32.53	281	14	P	V
													V
													V
													V
Remark	1. No other spurious found. 2. All results are PASS against Peak and Average limit line.												



Band 3 - 5470~5725MHz

WIFI 802.11ax HE20 (Full RU) (Harmonic @ 3m)

WIFI Ant. 1+2	Note	Frequency (MHz)	Level (dBμV/m)	Over Limit (dB)	Limit Line (dBμV/m)	Read Level (dBμV)	Antenna Factor (dB/m)	Path Loss (dB)	Preamp Factor (dB)	Ant Pos (cm)	Table Pos (deg)	Peak Avg. (P/A)	Pol. (H/V)	
802.11ax HE20 (Full RU) CH 100 5500MHz		11000	45.7	-28.3	74	52.34	40	16.76	63.4	100	0	P	H	
		16500	44.87	-23.33	68.2	47.58	38.4	21.19	62.3	100	0	P	H	
													H	
													H	
			11000	45.92	-28.08	74	52.56	40	16.76	63.4	100	0	P	V
			16500	45.29	-22.91	68.2	48	38.4	21.19	62.3	100	0	P	V
802.11ax HE20 (Full RU) CH 116 5580MHz		11160	46.79	-27.21	74	53.75	39.48	16.99	63.43	100	0	P	H	
		16740	46.04	-22.16	68.2	47.31	39.38	21.51	62.16	100	0	P	H	
													H	
													H	
			11160	45.76	-28.24	74	52.72	39.48	16.99	63.43	100	0	P	V
			16740	45.44	-22.76	68.2	46.71	39.38	21.51	62.16	100	0	P	V
802.11ax HE20 (Full RU) CH 140 5700MHz		11400	46.29	-27.71	74	52.73	39.7	16.87	63.48	100	0	P	H	
		17100	46.98	-21.22	68.2	47.19	39.7	21.45	61.86	100	0	P	H	
													H	
													H	
			11400	45.26	-28.74	74	51.7	39.7	17.34	63.48	100	0	P	V
			17100	47.49	-20.71	68.2	47.7	39.7	21.95	61.86	100	0	P	V
Remark	1. No other spurious found.													
	2. All results are PASS against Peak and Average limit line.													



Band 3 - 5470~5725MHz
WIFI 802.11ax HE40 (Full RU) (Band Edge @ 3m)

WIFI Ant. 1+2	Note	Frequency (MHz)	Level (dBμV/m)	Over Limit (dB)	Limit Line (dBμV/m)	Read Level (dBμV)	Antenna Factor (dB/m)	Path Loss (dB)	Preamp Factor (dB)	Ant Pos (cm)	Table Pos (deg)	Peak Avg. (P/A)	Pol. (H/V)
802.11ax HE40 (Full RU) CH 102 5510MHz		5459.44	59.67	-14.33	74	50.31	31.74	10.24	32.62	261	15	P	H
		5468.8	64.78	-3.42	68.2	55.35	31.78	10.26	32.61	261	15	P	H
		5459.68	46.36	-7.64	54	37	31.74	10.24	32.62	261	15	A	H
	*	5510	108.79	-	-	99.18	31.88	10.32	32.59	261	15	P	H
	*	5510	98.24	-	-	88.63	31.88	10.32	32.59	261	15	A	H
		5734.76	50.58	-17.62	68.2	40.4	32.17	10.53	32.52	261	15	P	H
		5459.44	56.35	-17.65	74	46.99	31.74	10.24	32.62	301	346	P	V
		5468.32	61.38	-6.82	68.2	51.96	31.77	10.26	32.61	301	346	P	V
		5459.92	44.33	-9.67	54	34.97	31.74	10.24	32.62	301	346	A	V
	*	5510	106.78	-	-	97.17	31.88	10.32	32.59	301	346	P	V
	*	5510	96.95	-	-	87.34	31.88	10.32	32.59	301	346	A	V
		5746.1	51.2	-17	68.2	40.99	32.19	10.54	32.52	301	346	P	V
802.11ax HE40 (Full RU) CH 110 5550MHz		5455.12	61.65	-12.35	74	52.31	31.72	10.24	32.62	273	20	P	H
		5467.84	64.25	-3.95	68.2	54.83	31.77	10.26	32.61	273	20	P	H
		5459.92	49.41	-4.59	54	40.05	31.74	10.24	32.62	273	20	A	H
	*	5550	113.37	-	-	103.77	31.8	10.38	32.58	273	20	P	H
	*	5550	102.53	-	-	92.93	31.8	10.38	32.58	273	20	A	H
		5763.74	51.11	-17.09	68.2	40.85	32.23	10.55	32.52	273	20	P	H
		5458	55.77	-18.23	74	46.42	31.73	10.24	32.62	201	13	P	V
		5470	57.2	-11	68.2	47.77	31.78	10.26	32.61	201	13	P	V
		5459.92	46.15	-7.85	54	36.79	31.74	10.24	32.62	201	13	A	V
	*	5550	111.6	-	-	102	31.8	10.38	32.58	201	13	P	V
	*	5550	101.27	-	-	91.67	31.8	10.38	32.58	201	13	A	V
		5734.76	51.23	-16.97	68.2	41.05	32.17	10.53	32.52	201	13	P	V



802.11ax HE40 (Full RU) CH 134 5670MHz		5451.15	49.28	-24.72	74	39.97	31.7	10.23	32.62	258	28	P	H
		5464.45	48.88	-19.32	68.2	39.48	31.76	10.25	32.61	258	28	P	H
		5458.15	39.68	-14.32	54	30.33	31.73	10.24	32.62	258	28	A	H
	*	5670	106.75	-	-	96.87	31.92	10.5	32.54	258	28	P	H
	*	5670	96.82	-	-	86.94	31.92	10.5	32.54	258	28	A	H
		5725.275	62.72	-5.48	68.2	52.57	32.15	10.53	32.53	258	28	P	H
		5440.3	49.11	-24.89	74	39.85	31.68	10.21	32.63	272	30	P	V
		5467.6	49.04	-19.16	68.2	39.63	31.77	10.25	32.61	272	30	P	V
		5458.85	39.65	-14.35	54	30.29	31.74	10.24	32.62	272	30	A	V
	*	5670	108.26	-	-	98.38	31.92	10.5	32.54	272	30	P	V
	*	5670	98.41	-	-	88.53	31.92	10.5	32.54	272	30	A	V
		5725.1	64.18	-4.02	68.2	54.03	32.15	10.53	32.53	272	30	P	V
Remark	1. No other spurious found. 2. All results are PASS against Peak and Average limit line.												



Band 3 5470~5725MHz
WIFI 802.11ax HE80 (Full RU) (Band Edge @ 3m)

WIFI Ant. 1+2	Note	Frequency (MHz)	Level (dBμV/m)	Over Limit (dB)	Limit Line (dBμV/m)	Read Level (dBμV)	Antenna Factor (dB/m)	Path Loss (dB)	Preamp Factor (dB)	Ant Pos (cm)	Table Pos (deg)	Peak Avg. (P/A)	Pol. (H/V)
802.11ax HE80 (Full RU) CH 106 5530MHz		5458.24	62.29	-11.71	74	52.94	31.73	10.24	32.62	216	9	P	H
		5461.12	62.58	-5.62	68.2	53.21	31.74	10.24	32.61	216	9	P	H
		5459.92	48.51	-5.49	54	39.15	31.74	10.24	32.62	216	9	A	H
	*	5530	99.84	-	-	90.23	31.84	10.35	32.58	216	9	P	H
	*	5530	92.28	-	-	82.67	31.84	10.35	32.58	216	9	A	H
		5740.745	51.72	-16.48	68.2	41.52	32.18	10.54	32.52	216	9	P	H
		5456.8	60.32	-13.68	74	50.97	31.73	10.24	32.62	354	355	P	V
		5469.28	62.19	-6.01	68.2	52.76	31.78	10.26	32.61	354	355	P	V
		5459.68	49.12	-4.88	54	39.76	31.74	10.24	32.62	354	355	A	V
	*	5530	101.05	-	-	91.44	31.84	10.35	32.58	354	355	P	V
	*	5530	92.18	-	-	82.57	31.84	10.35	32.58	354	355	A	V
			5727.2	51.75	-16.45	68.2	41.6	32.15	10.53	32.53	354	355	P
Remark	1. No other spurious found. 2. All results are PASS against Peak and Average limit line.												



Band 3 5470~5725MHz

WIFI 802.11ax HE80 (Full RU) (Harmonic @ 3m)

WIFI Ant. 1+2	Note	Frequency (MHz)	Level (dBμV/m)	Over Limit (dB)	Limit Line (dBμV/m)	Read Level (dBμV)	Antenna Factor (dB/m)	Path Loss (dB)	Preamp Factor (dB)	Ant Pos (cm)	Table Pos (deg)	Peak Avg. (P/A)	Pol. (H/V)	
802.11ax HE80 (Full RU) CH 106 5530MHz		11060	47.38	-26.62	74	54.18	39.76	16.85	63.41	100	0	P	H	
		16900	47.46	-20.74	68.2	47.9	39.9	21.72	62.06	100	0	P	H	
													H	
													H	
			11060	47.1	-26.9	74	53.9	39.76	16.85	63.41	100	0	P	V
			16900	48.07	-20.13	68.2	48.51	39.9	21.72	62.06	100	0	P	V
														V
														V
Remark	1. No other spurious found. 2. All results are PASS against Peak and Average limit line.													



Band 3 - 5470~5725MHz

WIFI 802.11ax HE40 (Full RU) (Harmonic @ 3m)

WIFI Ant. 1+2	Note	Frequency (MHz)	Level (dBμV/m)	Over Limit (dB)	Limit Line (dBμV/m)	Read Level (dBμV)	Antenna Factor (dB/m)	Path Loss (dB)	Preamp Factor (dB)	Ant Pos (cm)	Table Pos (deg)	Peak Avg. (P/A)	Pol. (H/V)	
802.11ax HE40 (Full RU) CH 102 5510MHz		11020	46.4	-27.6	74	53.09	39.92	16.79	63.4	100	0	P	H	
		16530	45.75	-22.45	68.2	48.28	38.52	21.23	62.28	100	0	P	H	
													H	
													H	
			11020	45.86	-28.14	74	52.55	39.92	16.79	63.4	100	0	P	V
			16530	45.32	-22.88	68.2	47.85	38.52	21.23	62.28	100	0	P	V
														V
802.11ax HE40 (Full RU) CH 110 5550MHz		11100	45.5	-28.5	74	52.41	39.6	16.91	63.42	100	0	P	H	
		16650	45.13	-23.07	68.2	47	38.95	21.39	62.21	100	0	P	H	
													H	
													H	
			11100	45.34	-28.66	74	52.25	39.6	16.91	63.42	100	0	P	V
			16650	45.4	-22.8	68.2	47.27	38.95	21.39	62.21	100	0	P	V
														V
802.11ax HE40 (Full RU) CH 134 5670MHz		11340	46.78	-27.22	74	53.47	39.52	17.26	63.47	100	0	P	H	
		17010	48.56	-19.64	68.2	48.98	39.7	21.87	61.99	100	0	P	H	
													H	
													H	
			11340	46.47	-27.53	74	53.16	39.52	17.26	63.47	100	0	P	V
			17010	48.2	-20	68.2	48.62	39.7	21.87	61.99	100	0	P	V
														V
Remark	1. No other spurious found.													
	2. All results are PASS against Peak and Average limit line.													



Band 3 - 5470~5725MHz

WIFI 802.11ax HE20 (Partial 26 ORU) (Band Edge @ 3m)

WIFI Ant. 1+2	Note	Frequency (MHz)	Level (dBμV/m)	Over Limit (dB)	Limit Line (dBμV/m)	Read Level (dBμV)	Antenna Factor (dB/m)	Path Loss (dB)	Preamp Factor (dB)	Ant Pos (cm)	Table Pos (deg)	Peak Avg. (P/A)	Pol. (H/V)	
802.11ax HE20 CH 100 5500MHz		5445.36	49.45	-24.55	74	40.16	31.69	10.22	32.62	275	25	P	H	
		5464.4	49.01	-19.19	68.2	39.61	31.76	10.25	32.61	275	25	P	H	
		5459.92	40.01	-13.99	54	30.65	31.74	10.24	32.62	275	25	A	H	
	*	5500	110.59	-	-	100.97	31.9	10.31	32.59	275	25	P	H	
	*	5500	104.22	-	-	94.6	31.9	10.31	32.59	275	25	A	H	
														H
			5415.44	50.88	-23.12	74	41.72	31.63	10.17	32.64	220	20	P	V
			5462.8	49.61	-18.59	68.2	40.22	31.75	10.25	32.61	220	20	P	V
			5458.8	39.79	-14.21	54	30.43	31.74	10.24	32.62	220	20	A	V
	*		5500	107	-	-	97.38	31.9	10.31	32.59	220	20	P	V
	*		5500	102.23	-	-	92.61	31.9	10.31	32.59	220	20	A	V
													V	
Remark	1. No other spurious found. 2. All results are PASS against Peak and Average limit line.													



Band 3 - 5470~5725MHz

WIFI 802.11ax HE20 (Partial 26 8RU) (Band Edge @ 3m)

WIFI Ant. 1+2	Note	Frequency (MHz)	Level (dBμV/m)	Over Limit (dB)	Limit Line (dBμV/m)	Read Level (dBμV)	Antenna Factor (dB/m)	Path Loss (dB)	Preamp Factor (dB)	Ant Pos (cm)	Table Pos (deg)	Peak Avg. (P/A)	Pol. (H/V)
802.11ax HE20 CH 140 5700MHz	*	5700	112.01	-	-	101.93	32.1	10.51	32.53	240	11	P	H
	*	5700	105.35	-	-	95.27	32.1	10.51	32.53	240	11	A	H
		5726.28	62.02	-6.18	68.2	51.87	32.15	10.53	32.53	240	11	P	H
													H
													H
													H
	*	5700	115.5	-	-	105.42	32.1	10.51	32.53	257	18	P	V
	*	5700	108.51	-	-	98.43	32.1	10.51	32.53	257	18	A	V
		5726.12	64.62	-3.58	68.2	54.47	32.15	10.53	32.53	257	18	P	V
													V
												V	
												V	
Remark	1. No other spurious found. 2. All results are PASS against Peak and Average limit line.												



Band 3 - 5470~5725MHz

WIFI 802.11ax HE20 (Partial 52 37RU) (Band Edge @ 3m)

WIFI Ant. 1+2	Note	Frequency (MHz)	Level (dBμV/m)	Over Limit (dB)	Limit Line (dBμV/m)	Read Level (dBμV)	Antenna Factor (dB/m)	Path Loss (dB)	Preamp Factor (dB)	Ant Pos (cm)	Table Pos (deg)	Peak Avg. (P/A)	Pol. (H/V)	
802.11ax HE20 CH 100 5500MHz		5456.88	50.37	-23.63	74	41.02	31.73	10.24	32.62	271	21	P	H	
		5465.36	49.7	-18.5	68.2	40.3	31.76	10.25	32.61	271	21	P	H	
		5458.32	39.64	-14.36	54	30.29	31.73	10.24	32.62	271	21	A	H	
	*	5500	112.49	-	-	102.87	31.9	10.31	32.59	271	21	P	H	
	*	5500	103.63	-	-	94.01	31.9	10.31	32.59	271	21	A	H	
														H
			5435.44	50.05	-23.95	74	40.81	31.67	10.2	32.63	273	23	P	V
			5468.72	50.41	-17.79	68.2	40.99	31.77	10.26	32.61	273	23	P	V
			5459.92	39.52	-14.48	54	30.16	31.74	10.24	32.62	273	23	A	V
	*		5500	111.35	-	-	101.73	31.9	10.31	32.59	273	23	P	V
	*		5500	101.97	-	-	92.35	31.9	10.31	32.59	273	23	A	V
														V
Remark	1. No other spurious found. 2. All results are PASS against Peak and Average limit line.													



Band 3 - 5470~5725MHz

WIFI 802.11ax HE20 (Partial 52 40RU) (Band Edge @ 3m)

WIFI Ant. 1+2	Note	Frequency (MHz)	Level (dBμV/m)	Over Limit (dB)	Limit Line (dBμV/m)	Read Level (dBμV)	Antenna Factor (dB/m)	Path Loss (dB)	Preamp Factor (dB)	Ant Pos (cm)	Table Pos (deg)	Peak Avg. (P/A)	Pol. (H/V)
802.11ax HE20 CH 140 5700MHz	*	5700	110.22	-	-	100.14	32.1	10.51	32.53	238	12	P	H
	*	5700	102.01	-	-	91.93	32.1	10.51	32.53	238	12	A	H
		5725.4	59.72	-8.48	68.2	49.57	32.15	10.53	32.53	238	12	P	H
													H
													H
													H
	*	5700	114.29	-	-	104.21	32.1	10.51	32.53	283	19	P	V
	*	5700	106.06	-	-	95.98	32.1	10.51	32.53	283	19	A	V
		5725.4	64.61	-3.59	68.2	54.46	32.15	10.53	32.53	283	19	P	V
													V
												V	
												V	
Remark	1. No other spurious found. 2. All results are PASS against Peak and Average limit line.												



Band 3 - 5470~5725MHz

WIFI 802.11ax HE20 (Partial 106 53RU) (Band Edge @ 3m)

WIFI Ant. 1+2	Note	Frequency (MHz)	Level (dBμV/m)	Over Limit (dB)	Limit Line (dBμV/m)	Read Level (dBμV)	Antenna Factor (dB/m)	Path Loss (dB)	Preamp Factor (dB)	Ant Pos (cm)	Table Pos (deg)	Peak Avg. (P/A)	Pol. (H/V)	
802.11ax HE20 CH 100 5500MHz		5454.96	50.23	-23.77	74	40.89	31.72	10.24	32.62	251	17	P	H	
		5466.8	50.68	-17.52	68.2	41.27	31.77	10.25	32.61	251	17	P	H	
		5458.96	39.64	-14.36	54	30.28	31.74	10.24	32.62	251	17	A	H	
	*	5500	112.06	-	-	102.44	31.9	10.31	32.59	251	17	P	H	
	*	5500	102.88	-	-	93.26	31.9	10.31	32.59	251	17	A	H	
														H
			5455.28	50.56	-23.44	74	41.22	31.72	10.24	32.62	302	346	P	V
			5465.84	50.3	-17.9	68.2	40.9	31.76	10.25	32.61	302	346	P	V
			5460	39.51	-14.49	54	30.15	31.74	10.24	32.62	302	346	A	V
	*		5500	110.64	-	-	101.02	31.9	10.31	32.59	302	346	P	V
	*		5500	101.75	-	-	92.13	31.9	10.31	32.59	302	346	A	V
														V
Remark	<ol style="list-style-type: none"> No other spurious found. All results are PASS against Peak and Average limit line. 													



Band 3 - 5470~5725MHz

WIFI 802.11ax HE20 (Partial 106 54RU) (Band Edge @ 3m)

WIFI Ant. 1+2	Note	Frequency (MHz)	Level (dBμV/m)	Over Limit (dB)	Limit Line (dBμV/m)	Read Level (dBμV)	Antenna Factor (dB/m)	Path Loss (dB)	Preamp Factor (dB)	Ant Pos (cm)	Table Pos (deg)	Peak Avg. (P/A)	Pol. (H/V)	
802.11ax HE20 CH 140 5700MHz	*	5700	110.98	-	-	100.9	32.1	10.51	32.53	258	354	P	H	
	*	5700	102.56	-	-	92.48	32.1	10.51	32.53	258	354	A	H	
		5725.4	60.59	-7.61	68.2	50.44	32.15	10.53	32.53	258	354	P	H	
													H	
													H	
													H	
	*	5700	114.26	-	-	104.18	32.1	10.51	32.53	300	21	P	V	
	*	5700	104.9	-	-	94.82	32.1	10.51	32.53	300	21	A	V	
			5725.48	64.6	-3.6	68.2	54.45	32.15	10.53	32.53	300	21	P	V
													V	
												V		
												V		
Remark	<ol style="list-style-type: none"> No other spurious found. All results are PASS against Peak and Average limit line. 													



Band 3 - 5470~5725MHz

WIFI 802.11ax HE40 (Partial 242 61RU) (Band Edge @ 3m)

WIFI Ant. 1+2	Note	Frequency (MHz)	Level (dBμV/m)	Over Limit (dB)	Limit Line (dBμV/m)	Read Level (dBμV)	Antenna Factor (dB/m)	Path Loss (dB)	Preamp Factor (dB)	Ant Pos (cm)	Table Pos (deg)	Peak Avg. (P/A)	Pol. (H/V)
802.11ax HE40 CH 102 5510MHz		5454.4	56.85	-17.15	74	47.52	31.72	10.23	32.62	283	24	P	H
		5470	63.5	-4.7	68.2	54.07	31.78	10.26	32.61	283	24	P	H
		5459.92	40.74	-13.26	54	31.38	31.74	10.24	32.62	283	24	A	H
	*	5510	111.09	-	-	101.48	31.88	10.32	32.59	283	24	P	H
	*	5510	101.55	-	-	91.94	31.88	10.32	32.59	283	24	A	H
		5748.935	51.67	-16.53	68.2	41.45	32.2	10.54	32.52	283	24	P	H
		5451.52	51.96	-22.04	74	42.64	31.71	10.23	32.62	288	24	P	V
		5469.52	57.91	-10.29	68.2	48.48	31.78	10.26	32.61	288	24	P	V
		5459.92	40.04	-13.96	54	30.68	31.74	10.24	32.62	288	24	A	V
	*	5510	109.28	-	-	99.67	31.88	10.32	32.59	288	24	P	V
	*	5510	99.74	-	-	90.13	31.88	10.32	32.59	288	24	A	V
			5752.085	51.02	-17.18	68.2	40.8	32.2	10.54	32.52	288	24	P
Remark	1. No other spurious found. 2. All results are PASS against Peak and Average limit line.												



Band 3 - 5470~5725MHz

WIFI 802.11ax HE40 (Partial 242 62RU) (Band Edge @ 3m)

WIFI Ant. 1+2	Note	Frequency (MHz)	Level (dBμV/m)	Over Limit (dB)	Limit Line (dBμV/m)	Read Level (dBμV)	Antenna Factor (dB/m)	Path Loss (dB)	Preamp Factor (dB)	Ant Pos (cm)	Table Pos (deg)	Peak Avg. (P/A)	Pol. (H/V)
802.11ax HE40 CH 134 5670MHz		5419.3	50.57	-23.43	74	41.39	31.64	10.18	32.64	280	20	P	H
		5469.7	50.22	-17.98	68.2	40.79	31.78	10.26	32.61	280	20	P	H
		5459.9	39.5	-14.5	54	30.14	31.74	10.24	32.62	280	20	A	H
	*	5670	112	-	-	102.12	31.92	10.5	32.54	280	20	P	H
	*	5670	102.07	-	-	92.19	31.92	10.5	32.54	280	20	A	H
		5726.5	64.81	-3.39	68.2	54.66	32.15	10.53	32.53	280	20	P	H
		5435.4	50.15	-23.85	74	40.91	31.67	10.2	32.63	272	21	P	V
		5462	50.17	-18.03	68.2	40.78	31.75	10.25	32.61	272	21	P	V
		5458.85	39.5	-14.5	54	30.14	31.74	10.24	32.62	272	21	A	V
	*	5670	113.44	-	-	103.56	31.92	10.5	32.54	272	21	P	V
	*	5670	103.77	-	-	93.89	31.92	10.5	32.54	272	21	A	V
			5725.275	64.77	-3.43	68.2	54.62	32.15	10.53	32.53	272	21	P
Remark	1. No other spurious found. 2. All results are PASS against Peak and Average limit line.												



Band 3 5470~5725MHz

WIFI 802.11ax HE80 (Partial 484 65RU) (Band Edge @ 3m)

WIFI Ant. 1+2	Note	Frequency (MHz)	Level (dBμV/m)	Over Limit (dB)	Limit Line (dBμV/m)	Read Level (dBμV)	Antenna Factor (dB/m)	Path Loss (dB)	Preamp Factor (dB)	Ant Pos (cm)	Table Pos (deg)	Peak Avg. (P/A)	Pol. (H/V)
802.11ax HE80 CH 106 5530MHz		5459.44	56.31	-17.69	74	46.95	31.74	10.24	32.62	263	24	P	H
		5469.76	63.18	-5.02	68.2	53.75	31.78	10.26	32.61	263	24	P	H
		5459.92	44.56	-9.44	54	35.2	31.74	10.24	32.62	263	24	A	H
	*	5530	108.12	-	-	98.51	31.84	10.35	32.58	263	24	P	H
	*	5530	97.83	-	-	88.22	31.84	10.35	32.58	263	24	A	H
		5725	50.68	-17.52	68.2	40.53	32.15	10.53	32.53	263	24	P	H
		5452.24	52.43	-21.57	74	43.11	31.71	10.23	32.62	257	344	P	V
		5469.76	56.87	-11.33	68.2	47.44	31.78	10.26	32.61	257	344	P	V
		5459.92	41.12	-12.88	54	31.76	31.74	10.24	32.62	257	344	A	V
	*	5530	107.09	-	-	97.48	31.84	10.35	32.58	257	344	P	V
	*	5530	97.32	-	-	87.71	31.84	10.35	32.58	257	344	A	V
		5759.96	50.92	-17.28	68.2	40.67	32.22	10.55	32.52	257	344	P	V
802.11ax HE80 CH 122 5610MHz		5451.85	59.19	-14.81	74	49.87	31.71	10.23	32.62	274	19	P	H
		5467.25	62.02	-6.18	68.2	52.61	31.77	10.25	32.61	274	19	P	H
		5459.9	48.71	-5.29	54	39.35	31.74	10.24	32.62	274	19	A	H
	*	5610	105.56	-	-	95.77	31.88	10.47	32.56	274	19	P	H
	*	5610	95.27	-	-	85.48	31.88	10.47	32.56	274	19	A	H
		5726.675	57.36	-10.84	68.2	47.21	32.15	10.53	32.53	274	19	P	H
		5459.2	56.19	-17.81	74	46.83	31.74	10.24	32.62	378	342	P	V
		5465.15	57.41	-10.79	68.2	48.01	31.76	10.25	32.61	378	342	P	V
		5459.9	45.93	-8.07	54	36.57	31.74	10.24	32.62	378	342	A	V
	*	5610	106.81	-	-	97.02	31.88	10.47	32.56	378	342	P	V
	*	5610	96.35	-	-	86.56	31.88	10.47	32.56	378	342	A	V
		5729.825	61.53	-6.67	68.2	51.37	32.16	10.53	32.53	378	342	P	V
Remark	1. No other spurious found. 2. All results are PASS against Peak and Average limit line.												



Band 3 5470~5725MHz

WIFI 802.11ax HE80 (Partial 484 65RU) (Harmonic @ 3m)

WIFI Ant. 1	Note	Frequency (MHz)	Level (dBμV/m)	Over Limit (dB)	Limit Line (dBμV/m)	Read Level (dBμV)	Antenna Factor (dB/m)	Path Loss (dB)	Preamp Factor (dB)	Ant Pos (cm)	Table Pos (deg)	Peak Avg. (P/A)	Pol. (H/V)	
802.11ac VHT80 CH 122 5610MHz		11220	45.56	-28.44	74	52.52	39.4	17.08	63.44	100	0	P	H	
		16830	45.44	-22.76	68.2	46.08	39.83	21.63	62.1	100	0	P	H	
													H	
													H	
			11220	45.28	-28.72	74	52.24	39.4	17.08	63.44	100	0	P	V
			16830	45.4	-22.8	68.2	46.04	39.83	21.63	62.1	100	0	P	V
														V
													V	
Remark	1. No other spurious found. 2. All results are PASS against Peak and Average limit line.													



Emission below 1GHz
WIFI 802.11ax HE20 (Full RU) (LF @ 3m)

WIFI Ant. 1+2	Note	Frequency (MHz)	Level (dBμV/m)	Over Limit (dB)	Limit Line (dBμV/m)	Read Level (dBμV)	Antenna Factor (dB/m)	Path Loss (dB)	Preamp Factor (dB)	Ant Pos (cm)	Table Pos (deg)	Peak Avg. (P/A)	Pol. (H/V)	
802.11ax HE20 (full RU) LF		30.97	22.77	-17.23	40	29.6	24.81	0.78	32.42	-	-	P	H	
		62.01	22.75	-17.25	40	42.46	11.7	1.09	32.5	-	-	P	H	
		72.68	20.8	-19.2	40	39.46	12.63	1.18	32.47	-	-	P	H	
		859.35	31.65	-14.35	46	30.32	29.11	4.12	31.9	-	-	P	H	
		892.33	31.94	-14.06	46	30.66	28.85	4.19	31.76	-	-	P	H	
		941.8	33.29	-12.71	46	29.74	30.41	4.32	31.18	100	0	P	H	
														H
														H
														H
														H
														H
														H
														H
														H
														H
			30.97	27.12	-12.88	40	33.95	24.81	0.78	32.42	-	-	P	V
			40.67	26.57	-13.43	40	38.79	19.4	0.86	32.48	-	-	P	V
			66.86	27.42	-12.58	40	46.73	12.06	1.12	32.49	100	0	P	V
			770.11	30.32	-15.68	46	30.1	28.4	3.89	32.07	-	-	P	V
			855.47	33.03	-12.97	46	31.65	29.19	4.11	31.92	-	-	P	V
		893.3	32.49	-13.51	46	31.23	28.83	4.19	31.76	-	-	P	V	
													V	
													V	
													V	
													V	
													V	
													V	
Remark	1. No other spurious found. 2. All results are PASS against limit line.													



Note symbol

*	Fundamental Frequency which can be ignored. However, the level of any unwanted emissions shall not exceed the level of the fundamental frequency.
!	Test result is over limit line.
P/A	Peak or Average
H/V	Horizontal or Vertical



A calculation example for radiated spurious emission is shown as below:

WIFI	Note	Frequency	Level	Over	Limit	Read	Antenna	Path	Preamp	Ant	Table	Peak	Pol.
Ant.				Limit	Line	Level	Factor	Loss	Factor	Pos	Pos	Avg.	
1+2		(MHz)	(dBμV/m)	(dB)	(dBμV/m)	(dBμV)	(dB/m)	(dB)	(dB)	(cm)	(deg)	(P/A)	(H/V)
802.11b		2390	55.45	-18.55	74	54.51	32.22	4.58	35.86	103	308	P	H
CH 01													
2412MHz		2390	43.54	-10.46	54	42.6	32.22	4.58	35.86	103	308	A	H

1. Path Loss(dB) = Cable loss(dB) + Filter loss(dB) + Attenuator loss(dB)
2. Level(dBμV/m) = Antenna Factor(dB/m) + Path Loss(dB) + Read Level(dBμV) - Preamp Factor(dB)
3. Over Limit(dB) = Level(dBμV/m) – Limit Line(dBμV/m)

For Peak Limit @ 2390MHz:

1. Level(dBμV/m)
= Antenna Factor(dB/m) + Path Loss(dB) + Read Level(dBμV) - Preamp Factor(dB)
= 32.22(dB/m) + 4.58(dB) + 54.51(dBμV) – 35.86 (dB)
= 55.45 (dBμV/m)
2. Over Limit(dB)
= Level(dBμV/m) – Limit Line(dBμV/m)
= 55.45(dBμV/m) – 74(dBμV/m)
= -18.55(dB)

For Average Limit @ 2390MHz:

1. Level(dBμV/m)
= Antenna Factor(dB/m) + Path Loss(dB) + Read Level(dBμV) - Preamp Factor(dB)
= 32.22(dB/m) + 4.58(dB) + 42.6(dBμV) – 35.86 (dB)
= 43.54 (dBμV/m)
2. Over Limit(dB) = Level(dBμV/m) – Limit Line(dBμV/m)
= 43.54(dBμV/m) – 54(dBμV/m)
= -10.46(dB)

Both peak and average measured complies with the limit line, so test result is “PASS”.



<WPC Mode>

Band 3 - 5470~5725MHz

WIFI 802.11ac VHT20 (Band Edge @ 3m)

WIFI Ant.	Note	Frequency	Level	Over Limit	Limit Line	Read Level	Antenna Factor	Path Loss	Preamp Factor	Ant Pos	Table Pos	Peak Avg.	Pol.
1		(MHz)	(dBμV/m)	(dB)	(dBμV/m)	(dBμV)	(dB/m)	(dB)	(dB)	(cm)	(deg)	(P/A)	(H/V)
802.11ac VHT20 CH 140 5700MHz	*	5700	110.42	-	-	100.34	32.1	10.51	32.53	181	306	P	H
	*	5700	102.29	-	-	92.21	32.1	10.51	32.53	181	306	A	H
		5725.88	62.25	-5.95	68.2	52.1	32.15	10.53	32.53	181	306	P	H
													H
													H
													H
	*	5700	107.32	-	-	97.24	32.1	10.51	32.53	117	311	P	V
	*	5700	99.03	-	-	88.95	32.1	10.51	32.53	117	311	A	V
		5725.88	58.64	-9.56	68.2	48.49	32.15	10.53	32.53	117	311	P	V
													V

Remark

- No other spurious found.
- All results are PASS against Peak and Average limit line.



**Band 3 - 5470~5725MHz
WIFI 802.11ac VHT20 (Harmonic @ 3m)**

WIFI Ant. 1	Note	Frequency (MHz)	Level (dBμV/m)	Over Limit (dB)	Limit Line (dBμV/m)	Read Level (dBμV)	Antenna Factor (dB/m)	Path Loss (dB)	Preamp Factor (dB)	Ant Pos (cm)	Table Pos (deg)	Peak Avg. (P/A)	Pol. (H/V)	
802.11ac VHT20 CH 140 5700MHz		11400	45.76	-28.24	74	52.2	39.7	17.34	63.48	100	0	P	H	
		17100	46.56	-21.64	68.2	46.77	39.7	21.95	61.86	100	0	P	H	
													H	
													H	
			11400	44.31	-29.69	74	50.75	39.7	17.34	63.48	100	0	P	V
			17100	45.92	-22.28	68.2	46.13	39.7	21.95	61.86	100	0	P	V
														V
														V
Remark	1. No other spurious found. 2. All results are PASS against Peak and Average limit line.													



Appendix D. Radiated Spurious Emission

Test Engineer :	Jimmy Chung · Karl Hou · Wilson Wu	Temperature :	21.5~23.5°C
		Relative Humidity :	49.5~55.5%

Note symbol

-L	Low channel location
-R	High channel location



<CDD Mode>

Band 1 - 5150~5250MHz
WIFI 802.11a (Band Edge @ 3m)

WIFI	Band 1 5150~5250MHz Band Edge @ 3m	
ANT	802.11a CH36 5180MHz	
1+2	Horizontal	Fundamental
Peak	<p>Site : 03CH13-HY Condition : PEAK_BE_74 3m HORN_9120D_1241 HORIZONTAL Detector : Peak Project : 9D0635 Mode : 1 Setting : 19.5</p>	<p>Site : 03CH13-HY Condition : PEAK(UNII) 3m HORN_9120D_1241 HORIZONTAL Detector : Peak Project : 9D0635 Mode : 1 Setting : 19.5</p>
Avg.	<p>Site : 03CH13-HY Condition : AVG_BE_54 3m HORN_9120D_1241 HORIZONTAL Detector : Peak Project : 9D0635 Mode : 1 Setting : 19.5</p>	Left blank



WIFI	Band 1 5150~5250MHz Band Edge @ 3m	
ANT	802.11a CH36 5180MHz	
1+2	Vertical	Fundamental
<p>Peak</p>	<p>Site : 03CH13-HY Condition : PEAK_BE_74 3m HORN_9120D_1241 VERTICAL RBW:1000.000KHz VBW:3000.000KHz SWT:Auto Detector : Peak Project : 9D0635 Mode : 1 Setting : 19.5</p>	<p>Site : 03CH13-HY Condition : PEAK(UNII) 3m HORN_9120D_1241 VERTICAL RBW:1000.000KHz VBW:3000.000KHz SWT:Auto Detector : Peak Project : 9D0635 Mode : 1 Setting : 19.5</p>
<p>Avg.</p>	<p>Site : 03CH13-HY Condition : AVG_BE_54 3m HORN_9120D_1241 VERTICAL RBW:1000.000KHz VBW:3000.000KHz SWT:Auto Detector : Peak Project : 9D0635 Mode : 1 Setting : 19.5</p>	<p>Left blank</p>

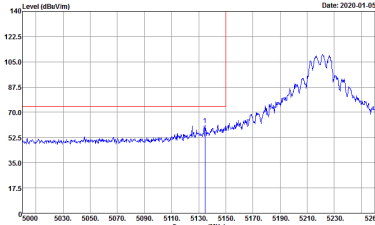
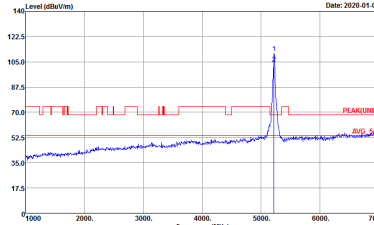
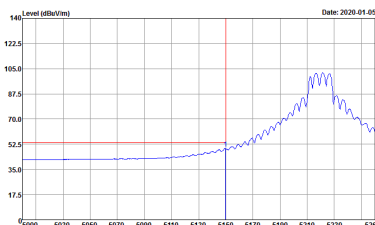

WIFI	Band 1 5150~5250MHz Band Edge @ 3m	
ANT	802.11a CH44 5220MHz - L	
1+2	Horizontal	Fundamental
<p>Peak</p>	 <p>Site : 03CH13-HY Condition : PEAK_BE_74 3m HORN_91200_1241 HORIZONTAL RBW:1000.000KHz VBW:3000.000KHz SWT:Auto Detector : Peak Project : 9D0635</p>	 <p>Site : 03CH13-HY Condition : PEAK(UNII) 3m HORN_91200_1241 HORIZONTAL RBW:1000.000KHz VBW:3000.000KHz SWT:Auto Detector : Peak Project : 9D0635</p>
<p>Avg.</p>	 <p>Site : 03CH13-HY Condition : AVG_BE_54 3m HORN_91200_1241 HORIZONTAL RBW:1000.000KHz VBW:3000.000KHz SWT:Auto Detector : Peak Project : 9D0635</p>	<p>Left blank</p>

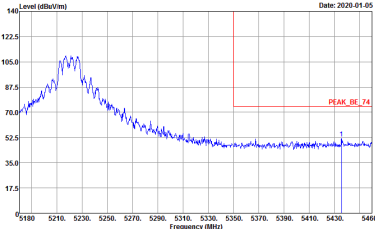
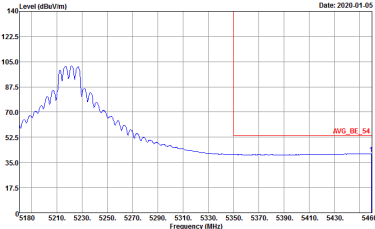

WIFI	Band 1 5150~5250MHz Band Edge @ 3m	
ANT	802.11a CH44 5220MHz - R	
1+2	Horizontal	Fundamental
<p>Peak</p>	 <p>Site : 03CH13-HY Condition : PEAK_BE_74 3m HORN_9120D_1241 HORIZONTAL Detector : Peak Project : 9D0635</p>	<p>Left blank</p>
<p>Avg.</p>	 <p>Site : 03CH13-HY Condition : AVG_BE_54 3m HORN_9120D_1241 HORIZONTAL Detector : Peak Project : 9D0635</p>	<p>Left blank</p>



WIFI	Band 1 5150~5250MHz Band Edge @ 3m	
ANT	802.11a CH44 5220MHz - L	
1+2	Vertical	Fundamental
Peak	<p>Site : 03CH13-HY Condition : PEAK_BE_74 3m HORN_9120D_1241 VERTICAL RBW:1000.000KHz VBW:3000.000KHz SWT:Auto Detector : Peak Project : 9D0635</p>	<p>Site : 03CH13-HY Condition : PEAK(UNII) 3m HORN_9120D_1241 VERTICAL RBW:1000.000KHz VBW:3000.000KHz SWT:Auto Detector : Peak Project : 9D0635</p>
Avg.	<p>Site : 03CH13-HY Condition : AVG_BE_54 3m HORN_9120D_1241 VERTICAL RBW:1000.000KHz VBW:3000.000KHz SWT:Auto Detector : Peak Project : 9D0635</p>	Left blank

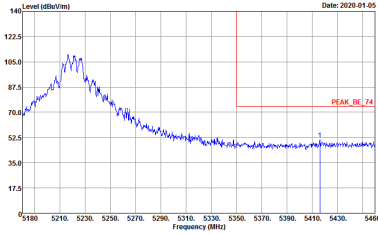
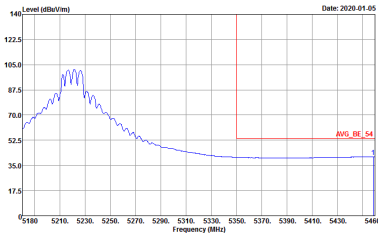

WIFI	Band 1 5150~5250MHz Band Edge @ 3m	
ANT	802.11a CH44 5220MHz - R	
1+2	Vertical	Fundamental
<p>Peak</p>	 <p>Site : 03CH13-HY Condition : PEAK_BE_74 3m HORN_9120D_1241 VERTICAL RBW:1000.000kHz VBW:3000.000kHz SWF:Auto Detector : Peak Project : 9D0635</p>	<p>Left blank</p>
<p>Avg.</p>	 <p>Site : 03CH13-HY Condition : AVG_BE_54 3m HORN_9120D_1241 VERTICAL RBW:1000.000kHz VBW:0.0100kHz SWF:Auto Detector : Peak Project : 9D0635</p>	<p>Left blank</p>

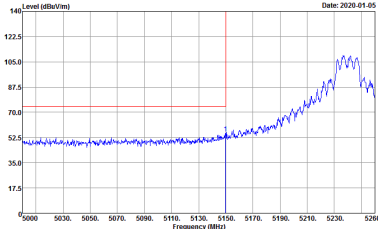
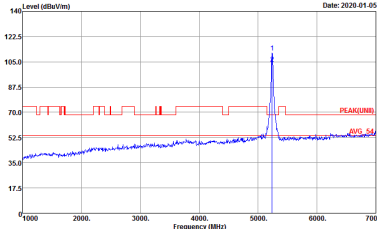
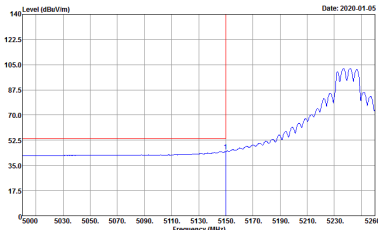

WIFI	Band 1 5150~5250MHz Band Edge @ 3m	
ANT	802.11a CH48 5240MHz - L	
1+2	Horizontal	Fundamental
Peak	 <p>Site : 03CH13-HY Condition : PEAK_BE_74 3m HORN_91200_1241 HORIZONTAL RBW:1000.000KHz VBW:3000.000KHz SWT:Auto Detector : Peak Project : 9D0635</p>	 <p>Site : 03CH13-HY Condition : PEAK(UNI) 3m HORN_91200_1241 HORIZONTAL RBW:1000.000KHz VBW:3000.000KHz SWT:Auto Detector : Peak Project : 9D0635</p>
Avg.	 <p>Site : 03CH13-HY Condition : AVG_BE_54 3m HORN_91200_1241 HORIZONTAL RBW:1000.000KHz VBW:3000.000KHz SWT:Auto Detector : Peak Project : 9D0635</p>	Left blank

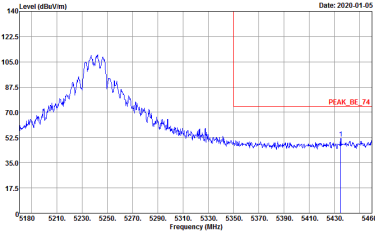
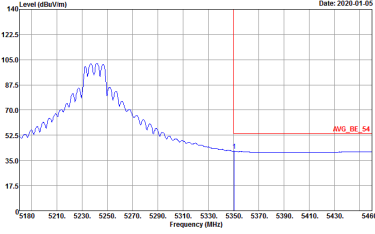

WIFI	Band 1 5150~5250MHz Band Edge @ 3m	
ANT	802.11a CH48 5240MHz - R	
1+2	Horizontal	Fundamental
<p>Peak</p>	 <p>Site : 03CH13-HY Condition : PEAK_BE_74 3m HORN_9120D_1241 HORIZONTAL RBW:1000.000kHz VBW:3000.000kHz SWT:Auto Detector : Peak Project : 9D0635</p>	<p>Left blank</p>
<p>Avg.</p>	 <p>Site : 03CH13-HY Condition : AVG_BE_54 3m HORN_9120D_1241 HORIZONTAL RBW:1000.000kHz VBW:3000.000kHz SWT:Auto Detector : Peak Project : 9D0635</p>	<p>Left blank</p>

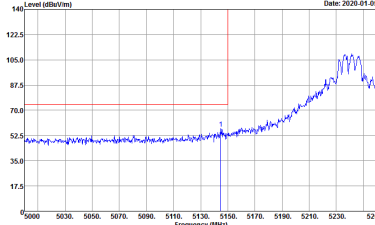
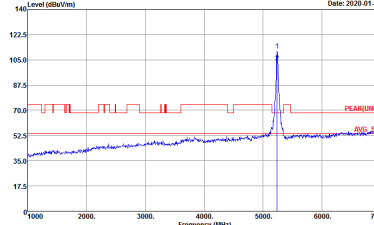
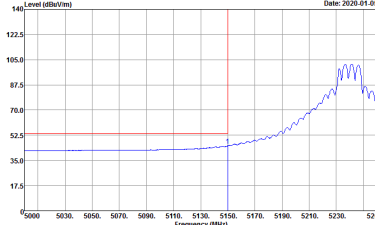

WIFI	Band 1 5150~5250MHz Band Edge @ 3m	
ANT	802.11a CH48 5240MHz - L	
1+2	Vertical	Fundamental
<p>Peak</p>	 <p>Site : 03CH13-HY Condition : PEAK_BE_74 3m HORN_91200_1241 VERTICAL RBW:1000.000KHz VBW:3000.000KHz SWT:Auto Detector : Peak Project : 9D0635</p>	 <p>Site : 03CH13-HY Condition : PEAK(UNI) 3m HORN_91200_1241 VERTICAL RBW:1000.000KHz VBW:3000.000KHz SWT:Auto Detector : Peak Project : 9D0635</p>
<p>Avg.</p>	 <p>Site : 03CH13-HY Condition : AVG_BE_54 3m HORN_91200_1241 VERTICAL RBW:1000.000KHz VBW:0.0100KHz SWT:Auto Detector : Peak Project : 9D0635</p>	<p>Left blank</p>

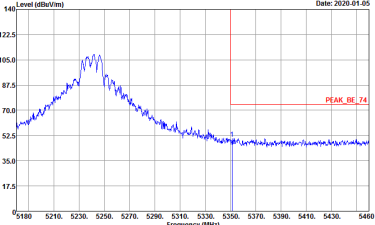
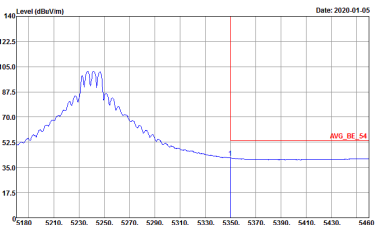

WIFI	Band 1 5150~5250MHz Band Edge @ 3m	
ANT	802.11a CH48 5240MHz - R	
1+2	Vertical	Fundamental
<p>Peak</p>	 <p>Site : 03CH13-HY Condition : PEAK_BE_74 3m HORN_9120D_1241 VERTICAL RBW:1000.000kHz VBW:3000.000kHz SWF:Auto Detector : Peak Project : 9D0635</p>	<p>Left blank</p>
<p>Avg.</p>	 <p>Site : 03CH13-HY Condition : AVG_BE_54 3m HORN_9120D_1241 VERTICAL RBW:1000.000kHz VBW:0.0100kHz SWF:Auto Detector : Peak Project : 9D0635</p>	<p>Left blank</p>



Band 1 5150~5250MHz
WIFI 802.11ac VHT20 (Band Edge @ 3m)

WIFI	Band 1 5150~5250MHz Band Edge @ 3m	
ANT	802.11ac VHT20 CH36 5180MHz	
1+2	Horizontal	Fundamental
Peak	<p> Site : 03CH13-HY Condition : PEAK_BE_74 3m HORN_91200_1241 HORIZONTAL : RBW:1000.000kHz VBW:3000.000kHz SWT:Auto Detector : Peak Project : 9D0635 Mode : 4 Setting : 19.5 </p>	<p> Site : 03CH13-HY Condition : PEAK(UNIT) 3m HORN_91200_1241 HORIZONTAL : RBW:1000.000kHz VBW:3000.000kHz SWT:Auto Detector : Peak Project : 9D0635 Mode : 4 Setting : 19.5 </p>
Avg.	<p> Site : 03CH13-HY Condition : AVG_BE_54 3m HORN_91200_1241 HORIZONTAL : RBW:1000.000kHz VBW:0.010kHz SWT:Auto Detector : Peak Project : 9D0635 Mode : 4 Setting : 19.5 </p>	<p>Left blank</p>



WIFI	Band 1 5150~5250MHz Band Edge @ 3m	
ANT	802.11ac VHT20 CH36 5180MHz	
1+2	Vertical	Fundamental
Peak	<p> Site : 03CH13-HY Condition : PEAK_BE_74 3m HORN_9120D_1241 VERTICAL RBW:1000.000KHz VBW:3000.000KHz SWT:Auto Detector : Peak Project : 9D0635 Mode : 4 Setting : 19.5 </p>	<p> Site : 03CH13-HY Condition : PEAK(UNII) 3m HORN_9120D_1241 VERTICAL RBW:1000.000KHz VBW:3000.000KHz SWT:Auto Detector : Peak Project : 9D0635 Mode : 4 Setting : 19.5 </p>
Avg.	<p> Site : 03CH13-HY Condition : AVG_BE_54 3m HORN_9120D_1241 VERTICAL RBW:1000.000KHz VBW:3000.000KHz SWT:Auto Detector : Peak Project : 9D0635 Mode : 4 Setting : 19.5 </p>	Left blank

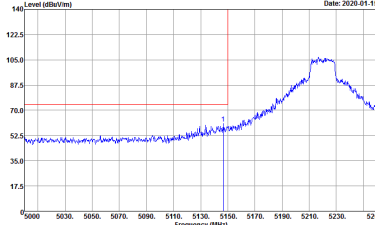
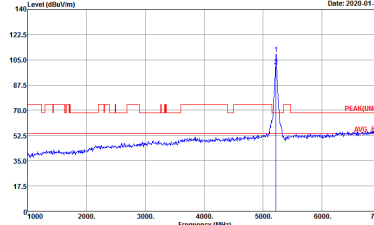
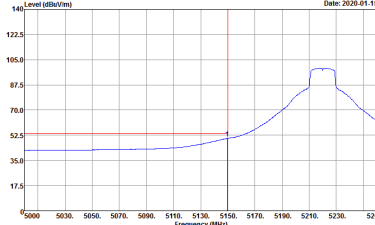

WIFI	Band 1 5150~5250MHz Band Edge @ 3m	
ANT	802.11ac VHT20 CH44 5220MHz - L	
1+2	Horizontal	Fundamental
<p>Peak</p>	 <p>Site : 03CH13-HY Condition : PEAK_BE_74 3m HORN_9120D_1241 HORIZONTAL RBW:1000.000KHz VBW:3000.000KHz SWT:Auto Detector : Peak Project : 9D0635 Mode : 5 Setting : 23.5</p>	 <p>Site : 03CH13-HY Condition : PEAK(UNII) 3m HORN_9120D_1241 HORIZONTAL RBW:1000.000KHz VBW:3000.000KHz SWT:Auto Detector : Peak Project : 9D0635 Mode : 5 Setting : 23.5</p>
<p>Avg.</p>	 <p>Site : 03CH13-HY Condition : AVG_BE_54 3m HORN_9120D_1241 HORIZONTAL RBW:1000.000KHz VBW:0.010KHz SWT:Auto Detector : Peak Project : 9D0635 Mode : 5 Setting : 23.5</p>	<p>Left blank</p>

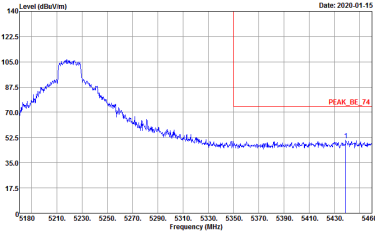
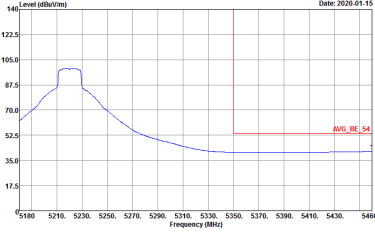

WIFI	Band 1 5150~5250MHz Band Edge @ 3m	
ANT	802.11ac VHT20 CH44 5220MHz - R	
1+2	Horizontal	Fundamental
<p>Peak</p>	 <p>Site : 03CH13-HY Condition : PEAK_BE_74 3m HORN_9120D_1241 HORIZONTAL Detector : Peak Project : 9D0635 Mode : 5 Setting : 23.5</p>	<p>Left blank</p>
<p>Avg.</p>	 <p>Site : 03CH13-HY Condition : AVG_BE_54 3m HORN_9120D_1241 HORIZONTAL Detector : Peak Project : 9D0635 Mode : 5 Setting : 23.5</p>	<p>Left blank</p>

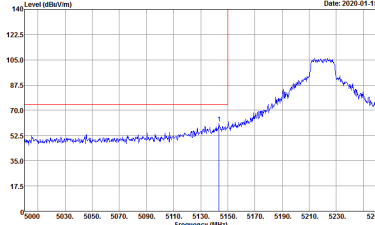
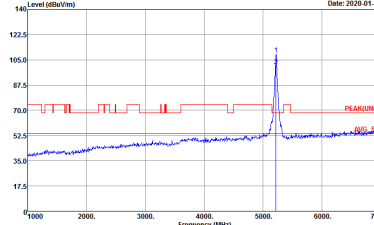
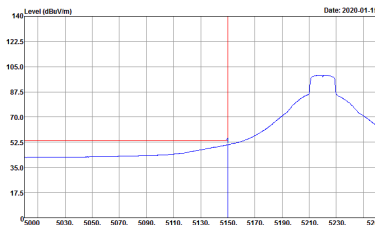

WIFI	Band 1 5150~5250MHz Band Edge @ 3m	
ANT	802.11ac VHT20 CH44 5220MHz - L	
1+2	Vertical	Fundamental
Peak	 <p>Site : 03CH13-HY Condition : PEAK_BE_74 3m HORN_91200_1241 VERTICAL Detector : Peak Project : 9D0635 Mode : 5 Setting : 23.5</p>	 <p>Site : 03CH13-HY Condition : PEAK(UNII) 3m HORN_91200_1241 VERTICAL Detector : Peak Project : 9D0635 Mode : 5 Setting : 23.5</p>
Avg.	 <p>Site : 03CH13-HY Condition : AVG_BE_54 3m HORN_91200_1241 VERTICAL Detector : Peak Project : 9D0635 Mode : 5 Setting : 23.5</p>	Left blank

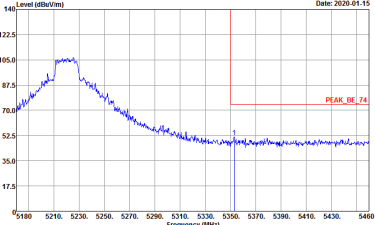
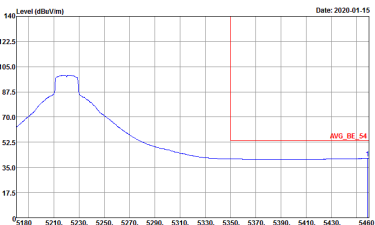

WIFI	Band 1 5150~5250MHz Band Edge @ 3m	
ANT	802.11ac VHT20 CH44 5220MHz - R	
1+2	Vertical	Fundamental
<p>Peak</p>	 <p>Site : 03CH13-HY Condition : PEAK_BE_74 3m HORN_9120D_1241 VERTICAL Detector : Peak Project : 9D0635 Mode : 5 Setting : 23.5</p>	<p>Left blank</p>
<p>Avg.</p>	 <p>Site : 03CH13-HY Condition : AVG_BE_54 3m HORN_9120D_1241 VERTICAL Detector : Peak Project : 9D0635 Mode : 5 Setting : 23.5</p>	<p>Left blank</p>

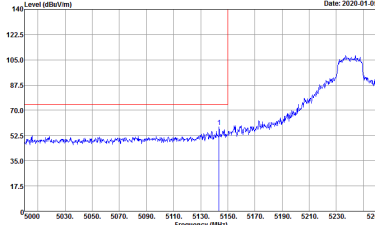
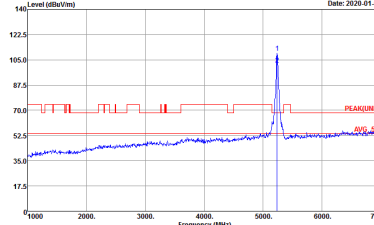
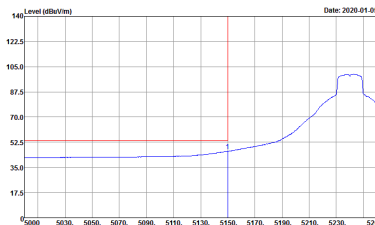

WIFI	Band 1 5150~5250MHz Band Edge @ 3m	
ANT	802.11ac VHT20 CH48 5240MHz - L	
1+2	Horizontal	Fundamental
<p>Peak</p>	 <p>Site : 03CH13-HY Condition : PEAK_BE_74 3m HORN_9120D_1241 HORIZONTAL RBW:1000.000KHz VBW:3000.000KHz SWT:Auto Detector : Peak Project : 9D0635</p>	 <p>Site : 03CH13-HY Condition : PEAK(UNII) 3m HORN_9120D_1241 HORIZONTAL RBW:1000.000KHz VBW:3000.000KHz SWT:Auto Detector : Peak Project : 9D0635</p>
<p>Avg.</p>	 <p>Site : 03CH13-HY Condition : AVG_BE_54 3m HORN_9120D_1241 HORIZONTAL RBW:1000.000KHz VBW:0.0100KHz SWT:Auto Detector : Peak Project : 9D0635</p>	<p>Left blank</p>

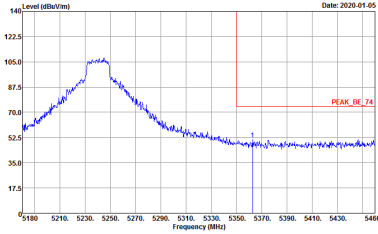
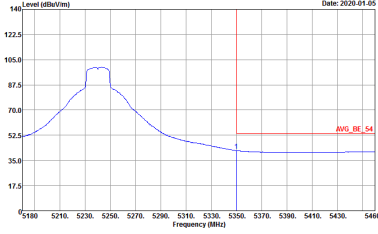

WIFI	Band 1 5150~5250MHz Band Edge @ 3m	
ANT	802.11ac VHT20 CH48 5240MHz - R	
1+2	Horizontal	Fundamental
<p>Peak</p>	 <p>Site : 03CH13-HY Condition : PEAK_BE_74 3m HORN_9120D_1241 HORIZONTAL RBW:1000.000kHz VBW:3000.000kHz SWT:Auto Detector : Peak Project : 9D0635</p>	<p>Left blank</p>
<p>Avg.</p>	 <p>Site : 03CH13-HY Condition : AVG_BE_54 3m HORN_9120D_1241 HORIZONTAL RBW:1000.000kHz VBW:3000.000kHz SWT:Auto Detector : Peak Project : 9D0635</p>	<p>Left blank</p>

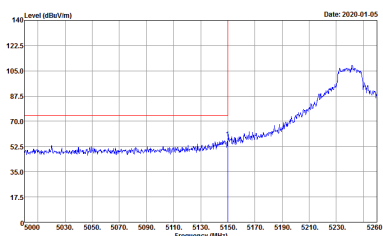
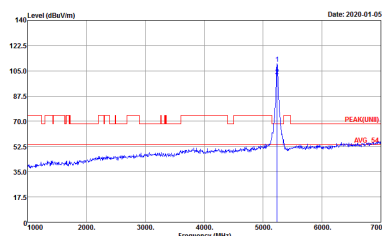
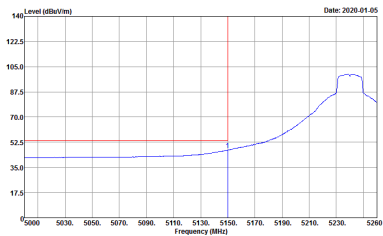

WIFI	Band 1 5150~5250MHz Band Edge @ 3m	
ANT	802.11ac VHT20 CH48 5240MHz - L	
1+2	Vertical	Fundamental
Peak	 <p>Site : 03CH13-HY Condition : PEAK_BE_74 3m HORN_9120D_1241 VERTICAL RBW:1000.000KHz VBW:3000.000KHz SWT:Auto Detector : Peak Project : 9D0635</p>	 <p>Site : 03CH13-HY Condition : PEAK(UNII) 3m HORN_9120D_1241 VERTICAL RBW:1000.000KHz VBW:3000.000KHz SWT:Auto Detector : Peak Project : 9D0635</p>
Avg.	 <p>Site : 03CH13-HY Condition : AVG_BE_54 3m HORN_9120D_1241 VERTICAL RBW:1000.000KHz VBW:3000.000KHz SWT:Auto Detector : Peak Project : 9D0635</p>	Left blank

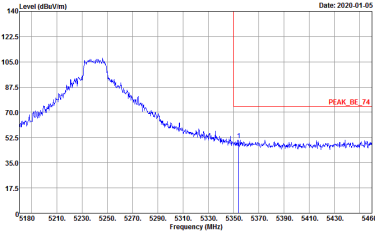
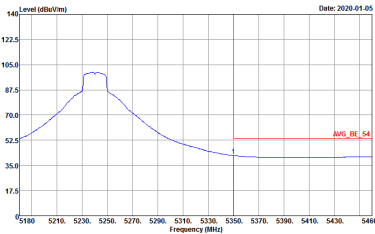

WIFI	Band 1 5150~5250MHz Band Edge @ 3m	
ANT	802.11ac VHT20 CH48 5240MHz - R	
1+2	Vertical	Fundamental
<p>Peak</p>	 <p>Site : 03CH13-HY Condition : PEAK_BE_74 3m HORN_9120D_1241 VERTICAL RBW:1000.000kHz VBW:3000.000kHz SWF:Auto Detector : Peak Project : 9D0635</p>	<p>Left blank</p>
<p>Avg.</p>	 <p>Site : 03CH13-HY Condition : AVG_BE_54 3m HORN_9120D_1241 VERTICAL RBW:1000.000kHz VBW:0.0100kHz SWF:Auto Detector : Peak Project : 9D0635</p>	<p>Left blank</p>



**Band 1 5150~5250MHz
WIFI 802.11ac VHT40 (Band Edge @ 3m)**

WIFI	Band 1 5150~5250MHz Band Edge @ 3m	
ANT	802.11ac VHT40 CH38 5190MHz - L	
1+2	Horizontal	Fundamental
Peak	<p> Site : 03CH13-HY Condition : PEAK_BE_74 3m HORN_91200_1241 VERTICAL : RBW:1000.000kHz VBW:3000.000kHz SWT:Auto Detector : Peak Project : 9D0635 Mode : 7 Setting : 17.5 </p>	<p> Site : 03CH13-HY Condition : PEAK(UNIT) 3m HORN_91200_1241 VERTICAL : RBW:1000.000kHz VBW:3000.000kHz SWT:Auto Detector : Peak Project : 9D0635 Mode : 7 Setting : 17.5 </p>
Avg.	<p> Site : 03CH13-HY Condition : AVG_BE_54 3m HORN_91200_1241 VERTICAL : RBW:1000.000kHz VBW:0.010kHz SWT:Auto Detector : Peak Project : 9D0635 Mode : 7 Setting : 17.5 </p>	<p>Left blank</p>

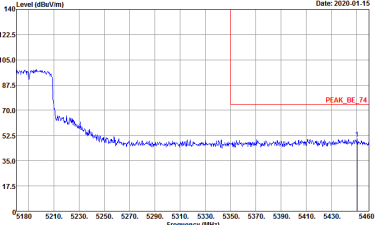
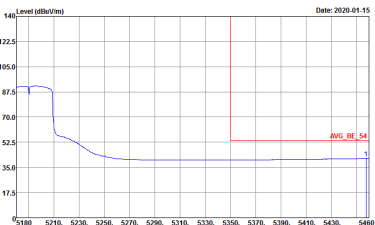

WIFI	Band 1 5150~5250MHz Band Edge @ 3m	
ANT	802.11ac VHT40 CH38 5190MHz - R	
1+2	Horizontal	Fundamental
<p>Peak</p>	 <p>Site : 03CH13-HY Condition : PEAK_BE_74 3m HORN_9120D_1241 VERTICAL Detector : Peak Project : 9D0635 Mode : 7 Setting : 17.5</p>	<p>Left blank</p>
<p>Avg.</p>	 <p>Site : 03CH13-HY Condition : AVG_BE_54 3m HORN_9120D_1241 VERTICAL Detector : Peak Project : 9D0635 Mode : 7 Setting : 17.5</p>	<p>Left blank</p>

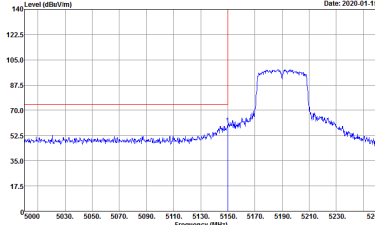
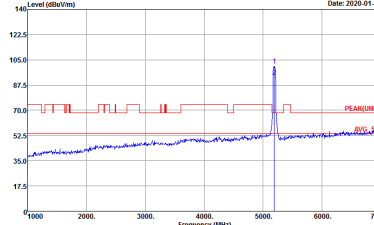
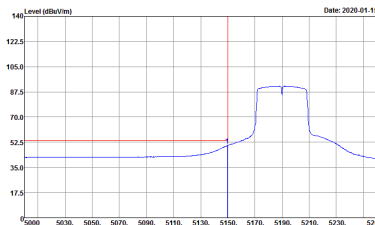

WIFI	Band 1 5150~5250MHz Band Edge @ 3m	
ANT	802.11ac VHT40 CH38 5190MHz - L	
1+2	Vertical	Fundamental
Peak	 <p>Site : 03CH13-HY Condition : PEAK_BE_74 3m HORN_9120D_1241 HORIZONTAL Detector : Peak Project : 9D0635 Mode : 7 Setting : 17.5</p>	 <p>Site : 03CH13-HY Condition : PEAK(UNII) 3m HORN_9120D_1241 HORIZONTAL Detector : Peak Project : 9D0635 Mode : 7 Setting : 17.5</p>
Avg.	 <p>Site : 03CH13-HY Condition : AVG_BE_54 3m HORN_9120D_1241 HORIZONTAL Detector : Peak Project : 9D0635 Mode : 7 Setting : 17.5</p>	Left blank

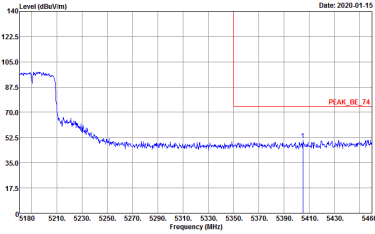
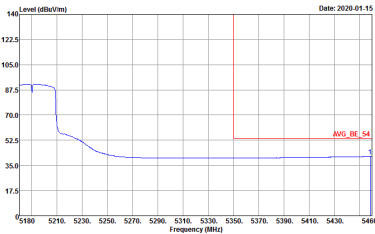

WIFI	Band 1 5150~5250MHz Band Edge @ 3m	
ANT	802.11ac VHT40 CH38 5190MHz - R	
1+2	Vertical	Fundamental
<p>Peak</p>	 <p>Site : 03CH13-HY Condition : PEAK_BE_74 3m HORN_9120D_1241 HORIZONTAL Detector : Peak Project : 9D0635 Mode : 7 Setting : 17.5</p>	<p>Left blank</p>
<p>Avg.</p>	 <p>Site : 03CH13-HY Condition : AVG_BE_54 3m HORN_9120D_1241 HORIZONTAL Detector : Peak Project : 9D0635 Mode : 7 Setting : 17.5</p>	<p>Left blank</p>

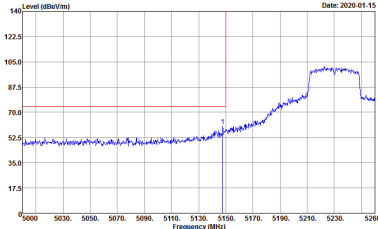
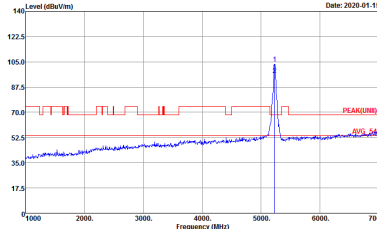
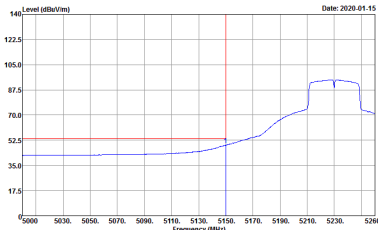

WIFI	Band 1 5150~5250MHz Band Edge @ 3m	
ANT	802.11ac VHT40 CH46 5230MHz - L	
1+2	Horizontal	Fundamental
<p>Peak</p>	 <p>Site : 03CH13-HY Condition : PEAK_BE_74 3m HORN_9120D_1241 HORIZONTAL Detector : Peak Project : 9D0635 Mode : 8 Setting : 20.5</p>	 <p>Site : 03CH13-HY Condition : PEAK(UNII) 3m HORN_9120D_1241 HORIZONTAL Detector : Peak Project : 9D0635 Mode : 8 Setting : 20.5</p>
<p>Avg.</p>	 <p>Site : 03CH13-HY Condition : AVG_BE_54 3m HORN_9120D_1241 HORIZONTAL Detector : Peak Project : 9D0635 Mode : 8 Setting : 20.5</p>	<p>Left blank</p>

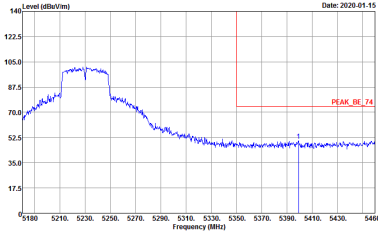
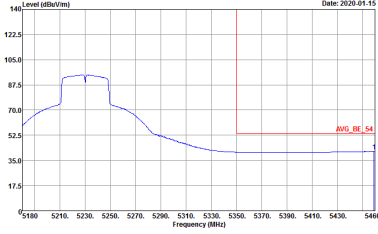

WIFI	Band 1 5150~5250MHz Band Edge @ 3m	
ANT	802.11ac VHT40 CH46 5230MHz - R	
1+2	Horizontal	Fundamental
<p>Peak</p>	 <p>Site : 03CH13-HY Condition : PEAK_BE_74 3m HORN_9120D_1241 HORIZONTAL Detector : Peak Project : 9D0635 Mode : 8 Setting : 20.5</p>	<p>Left blank</p>
<p>Avg.</p>	 <p>Site : 03CH13-HY Condition : AVG_BE_54 3m HORN_9120D_1241 HORIZONTAL Detector : Peak Project : 9D0635 Mode : 8 Setting : 20.5</p>	<p>Left blank</p>

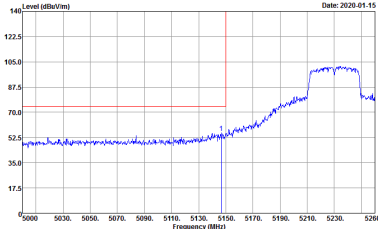
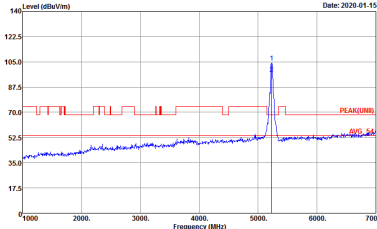
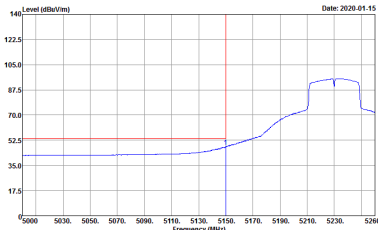

WIFI	Band 1 5150~5250MHz Band Edge @ 3m	
ANT	802.11ac VHT40 CH46 5230MHz - L	
1+2	Vertical	Fundamental
<p>Peak</p>	 <p>Site : 03CH13-HY Condition : PEAK_BE_74 3m HORN_9120D_1241 VERTICAL Detector : Peak Project : 9D0635 Mode : 8 Setting : 20.5</p>	 <p>Site : 03CH13-HY Condition : PEAK(UNII) 3m HORN_9120D_1241 VERTICAL Detector : Peak Project : 9D0635 Mode : 8 Setting : 20.5</p>
<p>Avg.</p>	 <p>Site : 03CH13-HY Condition : AVG_BE_54 3m HORN_9120D_1241 VERTICAL Detector : Peak Project : 9D0635 Mode : 8 Setting : 20.5</p>	<p>Left blank</p>

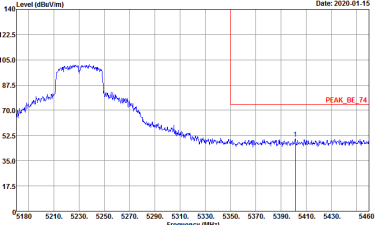
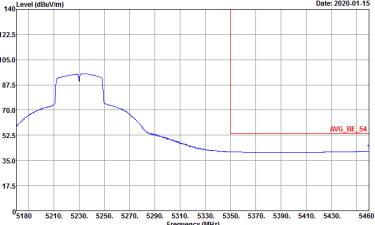

WIFI	Band 1 5150~5250MHz Band Edge @ 3m	
ANT	802.11ac VHT40 CH46 5230MHz - R	
1+2	Vertical	Fundamental
<p>Peak</p>	 <p>Site : 03CH13-HY Condition : PEAK_BE_74 3m HORN_9120D_1241 VERTICAL Detector : Peak Project : 9D0635 Mode : 8 Setting : 20.5</p>	<p>Left blank</p>
<p>Avg.</p>	 <p>Site : 03CH13-HY Condition : AVG_BE_54 3m HORN_9120D_1241 VERTICAL Detector : Peak Project : 9D0635 Mode : 8 Setting : 20.5</p>	<p>Left blank</p>



**Band 1 5150~5250MHz
WIFI 802.11ac VHT80 (Band Edge @ 3m)**

WIFI	Band 1 5150~5250MHz Band Edge @ 3m	
ANT	802.11ac VHT80 CH42 5210MHz - L	
1+2	Horizontal	Fundamental
Peak	<p>Site : 03CH13-HY Condition : PEAK_BE_74 3m HORN_91200_1241 HORIZONTAL RBW:1000.000kHz VBW:3000.000kHz SWT:Auto Detector : Peak Project : 9D0635 Mode : 9 Power : 17</p>	<p>Site : 03CH13-HY Condition : PEAK(UNIT) 3m HORN_91200_1241 HORIZONTAL RBW:1000.000kHz VBW:3000.000kHz SWT:Auto Detector : Peak Project : 9D0635 Mode : 9 Power : 17</p>
Avg.	<p>Site : 03CH13-HY Condition : AVG_BE_54 3m HORN_91200_1241 HORIZONTAL RBW:1000.000kHz VBW:0.010kHz SWT:Auto Detector : Peak Project : 9D0635 Mode : 9 Power : 17</p>	Left blank

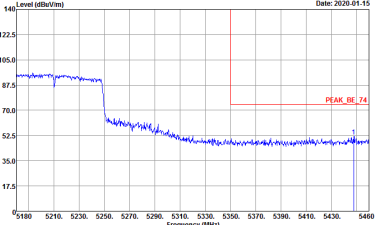
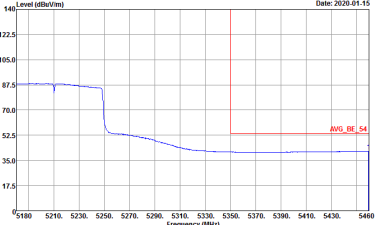

WIFI	Band 1 5150~5250MHz Band Edge @ 3m	
ANT	802.11ac VHT80 CH42 5210MHz - R	
1+2	Horizontal	Fundamental
<p>Peak</p>	 <p>Site : 03CH13-HY Condition : PEAK_BE_74 3m HORN_9120D_1241 HORIZONTAL Detector : Peak Project : 9D0635 Mode : 9 Power : 17</p>	<p>Left blank</p>
<p>Avg.</p>	 <p>Site : 03CH13-HY Condition : AVG_BE_54 3m HORN_9120D_1241 HORIZONTAL Detector : Peak Project : 9D0635 Mode : 9 Power : 17</p>	<p>Left blank</p>

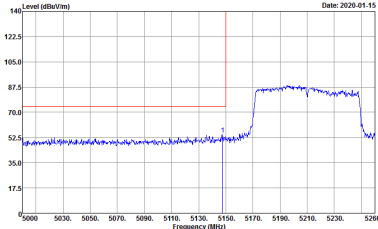
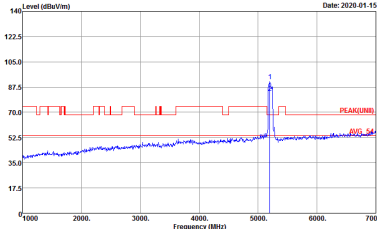
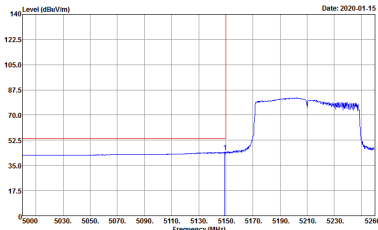

WIFI	Band 1 5150~5250MHz Band Edge @ 3m	
ANT	802.11ac VHT80 CH42 5210MHz - L	
1+2	Vertical	Fundamental
Peak	 <p>Site : 03CH13-HY Condition : PEAK_BE_74 3m HORN_9120D_1241 VERTICAL RBW:1000.000kHz VBW:3000.000kHz SWT:Auto Detector : Peak Project : 9D0635 Mode : 9 Power : 17</p>	 <p>Site : 03CH13-HY Condition : PEAK(UNII) 3m HORN_9120D_1241 VERTICAL RBW:1000.000kHz VBW:3000.000kHz SWT:Auto Detector : Peak Project : 9D0635 Mode : 9 Power : 17</p>
Avg.	 <p>Site : 03CH13-HY Condition : AVG_BE_54 3m HORN_9120D_1241 VERTICAL RBW:1000.000kHz VBW:3000.000kHz SWT:Auto Detector : Peak Project : 9D0635 Mode : 9 Power : 17</p>	Left blank

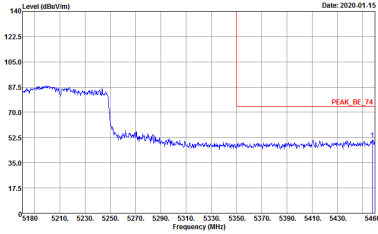
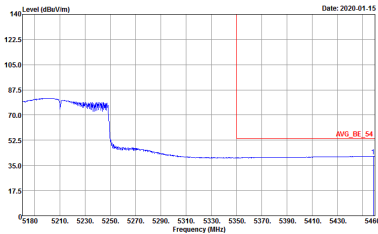

WIFI	Band 1 5150~5250MHz Band Edge @ 3m	
ANT	802.11ac VHT80 CH42 5210MHz - R	
1+2	Vertical	Fundamental
<p>Peak</p>	 <p>Site : 03CH13-HY Condition : PEAK_BE_74 3m HORN_9120D_1241 VERTICAL Detector : Peak Project : 9D0635 Mode : 9 Power : 17</p>	<p>Left blank</p>
<p>Avg.</p>	 <p>Site : 03CH13-HY Condition : AVG_BE_54 3m HORN_9120D_1241 VERTICAL Detector : Peak Project : 9D0635 Mode : 9 Power : 17</p>	<p>Left blank</p>



Band 1 - 5150~5250MHz
WIFI 802.11a (Harmonic @ 3m)

WIFI	Band 1 5150~5250MHz Harmonic @ 3m	
ANT	802.11a CH36 5180MHz	
1+2	Horizontal	Vertical
Peak Avg.	<p>Site : 03CH13-1FY Condition : PEAK(LINE) 3m HORN_91200_1241 HORIZONTAL Detector : Peak Project : 9D0635 Mode : 1</p>	<p>Site : 03CH13-1FY Condition : PEAK(LINE) 3m HORN_91200_1241 VERTICAL Detector : Peak Project : 9D0635 Mode : 1</p>

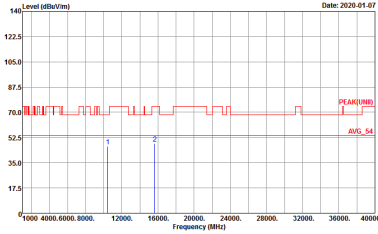
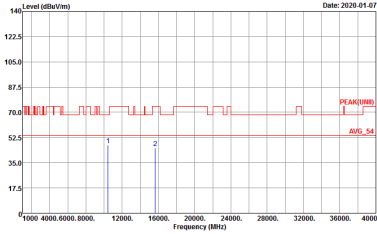

WIFI	Band 1 5150~5250MHz Harmonic @ 3m	
ANT	802.11a CH44 5220MHz	
1+2	Horizontal	Vertical
<p>Peak</p> <p>Avg.</p>	 <p>Site : 03CH12-HY Condition : PEAK(UNII) 3m HORN_91200_1241 HORIZONTAL Detector : Peak Project : 900635 Mode : 2</p>	 <p>Site : 03CH12-HY Condition : PEAK(UNII) 3m HORN_91200_1241 VERTICAL Detector : Peak Project : 900635 Mode : 2</p>



WIFI	Band 1 5150~5250MHz Harmonic @ 3m	
ANT	802.11a CH48 5240MHz	
1+2	Horizontal	Vertical
<p>Peak</p> <p>Avg.</p>	<p>Site : 03CH12-HY Condition : PEAK(UNII) 3m HORN_91200_1241 HORIZONTAL Detector : Peak Project : 900635 Mode : 3</p>	<p>Site : 03CH12-HY Condition : PEAK(UNII) 3m HORN_91200_1241 VERTICAL Detector : Peak Project : 900635 Mode : 3</p>



**Band 1 5150~5250MHz
WIFI 802.11ac VHT20 (Harmonic @ 3m)**

WIFI	Band 1 5150~5250MHz Harmonic @ 3m	
ANT	802.11ac VHT20 CH36 5180MHz	
1+2	Horizontal	Vertical
Peak Avg.	<p>Site : 03CH13-HY Condition : PEAK(UNII) 3m HORN_91200_1241 HORIZONTAL Detector : Peak Project : 9D0635</p>	<p>Site : 03CH13-HY Condition : PEAK(UNII) 3m HORN_91200_1241 VERTICAL Detector : Peak Project : 9D0635</p>



WIFI	Band 1 5150~5250MHz Harmonic @ 3m	
ANT	802.11ac VHT20 CH44 5220MHz	
1+2	Horizontal	Vertical
Peak Avg.	<p>Site : 03CH12-HY Condition : PEAK(UNII) 3m HORN_91200_1241 HORIZONTAL Detector : Peak Project : 9D0635</p>	<p>Site : 03CH12-HY Condition : PEAK(UNII) 3m HORN_91200_1241 VERTICAL Detector : Peak Project : 9D0635</p>



WIFI	Band 1 5150~5250MHz Harmonic @ 3m	
ANT	802.11ac VHT20 CH48 5240MHz	
1+2	Horizontal	Vertical
Peak Avg.	<p>Site : 03CH12-HY Condition : PEAK(UNII) 3m HORN_91200_1241 HORIZONTAL Detector : Peak Project : 9D0635</p>	<p>Site : 03CH12-HY Condition : PEAK(UNII) 3m HORN_91200_1241 VERTICAL Detector : Peak Project : 9D0635</p>



**Band 1 5150~5250MHz
WIFI 802.11ac VHT40 (Harmonic @ 3m)**

WIFI	Band 1 5150~5250MHz Harmonic @ 3m	
ANT	802.11ac VHT40 CH38 5190MHz	
1+2	Horizontal	Vertical
Peak Avg.	<p>Site : 03CH13-HY Condition : PEAK(UNII) 3m HORN_91200_1241 HORIZONTAL Detector : Peak Project : 9D0635</p>	<p>Site : 03CH13-HY Condition : PEAK(UNII) 3m HORN_91200_1241 VERTICAL Detector : Peak Project : 9D0635</p>



WIFI	Band 1 5150~5250MHz Harmonic @ 3m	
ANT	802.11ac VHT40 CH46 5230MHz	
1+2	Horizontal	Vertical
Peak Avg.	<p>Site : 03CH13-HY Condition : PEAK(UNII) 3m HORN_91200_1241 HORIZONTAL Detector : Peak Project : 9D0635</p>	<p>Site : 03CH13-HY Condition : PEAK(UNII) 3m HORN_91200_1241 VERTICAL Detector : Peak Project : 9D0635</p>



**Band 1 5150~5250MHz
WIFI 802.11ac VHT80 (Harmonic @ 3m)**

WIFI	Band 1 5150~5250MHz Harmonic @ 3m	
ANT	802.11ac VHT80 CH42 5210MHz	
1+2	Horizontal	Vertical
Peak Avg.	<p>Site : 03CH13-HY Condition : PEAK(UNII) 3m HORN_91200_1241 HORIZONTAL Detector : Peak Project : 9D0635</p>	<p>Site : 03CH13-HY Condition : PEAK(UNII) 3m HORN_91200_1241 VERTICAL Detector : Peak Project : 9D0635</p>



Emission below 1GHz
5GHz WIFI 802.11ac VHT80 (LF)

WIFI	5GHz WIFI	
ANT	802.11ac VHT80 LF	
1+2	Horizontal	Vertical
QP / Peak	<p>Site : 03CH13-HY Condition : QP 3m BTL0G_40103 HORIZONTAL Detector : Peak Project : 9500635 Mode : 68</p>	<p>Site : 03CH13-HY Condition : QP 3m BTL0G_40103 VERTICAL Detector : Peak Project : 9500635 Mode : 68</p>

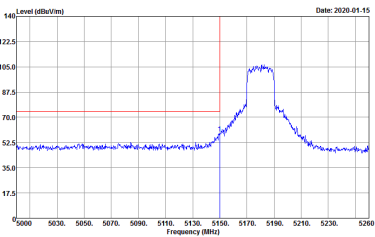
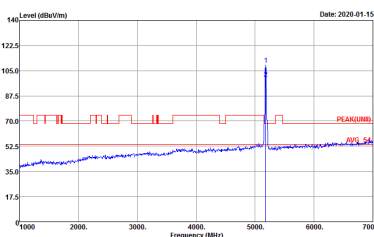
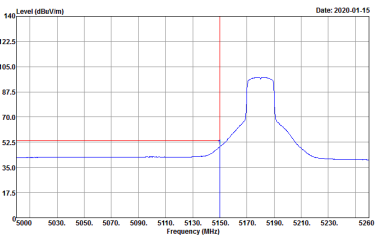

Band 1 - 5150~5250MHz
WIFI 802.11ax HE20 (Band Edge @ 3m)

WIFI	Band 1 5150~5250MHz Band Edge @ 3m	
ANT	802.11ax HE20 CH36 5180MHz	
1+2	Horizontal	Fundamental
<p>Peak</p>	 <p>Site : 03CH13-HY Condition : PEAK_BE_74 3m HORN_91200_1241 HORIZONTAL RBW:1000.000KHz VBW:3000.000KHz SWT:Auto Detector : Peak Project : 9D0635 Setting : 18.5</p>	 <p>Site : 03CH13-HY Condition : PEAK(LINII) 3m HORN_91200_1241 HORIZONTAL RBW:1000.000KHz VBW:3000.000KHz SWT:Auto Detector : Peak Project : 9D0635 Setting : 18.5</p>
<p>Avg.</p>	 <p>Site : 03CH13-HY Condition : AVG_BE_54 3m HORN_91200_1241 HORIZONTAL RBW:1000.000KHz VBW:3000.000KHz SWT:Auto Detector : Peak Project : 9D0635 Setting : 18.5</p>	<p align="center">Left blank</p>

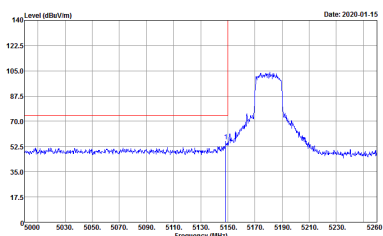
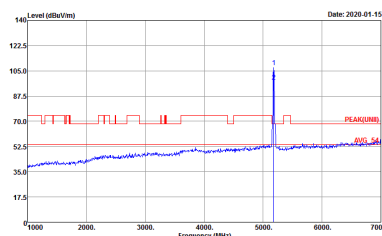
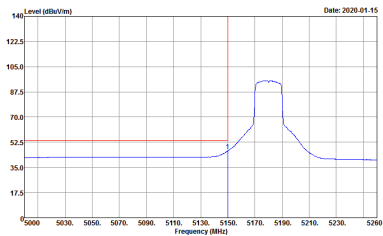

WIFI	Band 1 5150~5250MHz Band Edge @ 3m	
ANT	802.11ax HE20 CH36 5180MHz	
1+2	Vertical	Fundamental
<p>Peak</p>	 <p>Site : 03CH13-HY Condition : PEAK_BE_74 3m HORN_9120D_1241 VERTICAL Detector : Peak Project : 9D0635 Setting : 18.5</p>	 <p>Site : 03CH13-HY Condition : PEAK(UNII) 3m HORN_9120D_1241 VERTICAL Detector : Peak Project : 9D0635 Setting : 18.5</p>
<p>Avg.</p>	 <p>Site : 03CH13-HY Condition : AVG_BE_54 3m HORN_9120D_1241 VERTICAL Detector : Peak Project : 9D0635 Setting : 18.5</p>	<p>Left blank</p>



WIFI	Band 1 5150~5250MHz Band Edge @ 3m	
ANT	802.11ax HE20 CH44 5220MHz - L	
1+2	Horizontal	Fundamental
<p>Peak</p>		
<p>Avg.</p>		<p>Left blank</p>

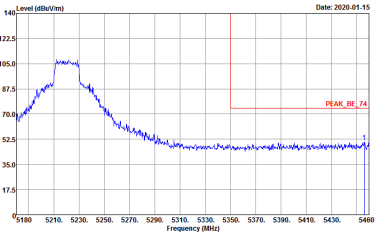
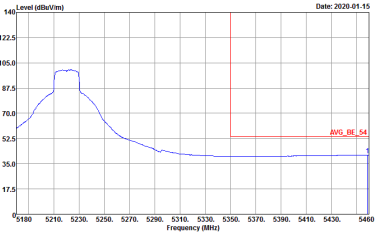

WIFI	Band 1 5150~5250MHz Band Edge @ 3m	
ANT	802.11ax HE20 CH44 5220MHz - R	
1+2	Horizontal	Fundamental
<p>Peak</p>	 <p>Site : 03CH13-HY Condition : PEAK_BE_74 3m HORN_9120D_1241 HORIZONTAL Detector : Peak Project : 9D0635 Setting : 23</p>	<p>Left blank</p>
<p>Avg.</p>	 <p>Site : 03CH13-HY Condition : AVG_BE_54 3m HORN_9120D_1241 HORIZONTAL Detector : Peak Project : 9D0635 Setting : 23</p>	<p>Left blank</p>

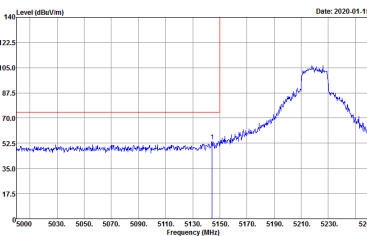
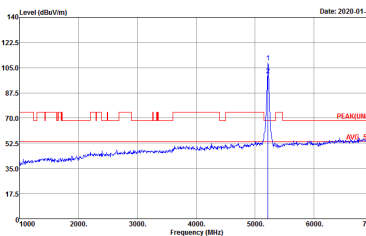
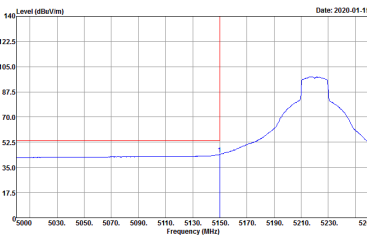

WIFI	Band 1 5150~5250MHz Band Edge @ 3m	
ANT	802.11ax HE20 CH44 5220MHz - L	
1+2	Vertical	Fundamental
Peak	 <p>Site : 03CH13-HY Condition : PEAK_BE_74 3m HORN_91200_1241 VERTICAL Detector : Peak Project : 9D0635 Setting : 23</p>	 <p>Site : 03CH13-HY Condition : PEAK(LINII) 3m HORN_91200_1241 VERTICAL Detector : Peak Project : 9D0635 Setting : 23</p>
Avg.	 <p>Site : 03CH13-HY Condition : AVG_BE_54 3m HORN_91200_1241 VERTICAL Detector : Peak Project : 9D0635 Setting : 23</p>	Left blank

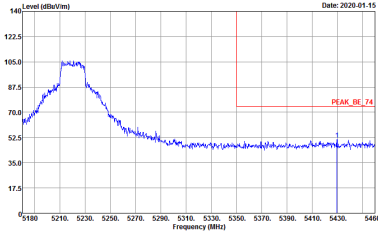
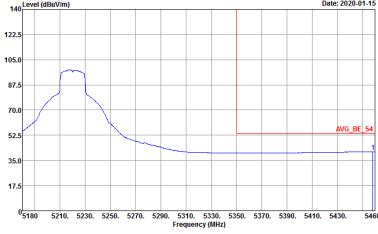

WIFI	Band 1 5150~5250MHz Band Edge @ 3m	
ANT	802.11ax HE20 CH44 5220MHz - R	
1+2	Vertical	Fundamental
<p>Peak</p>	 <p>Site : 03CH13-HY Condition : PEAK_BE_74 3m HORN_9120D_1241 VERTICAL Detector : Peak Project : 9D0635 Setting : 23</p>	<p>Left blank</p>
<p>Avg.</p>	 <p>Site : 03CH13-HY Condition : AVG_BE_54 3m HORN_9120D_1241 VERTICAL Detector : Peak Project : 9D0635 Setting : 23</p>	<p>Left blank</p>

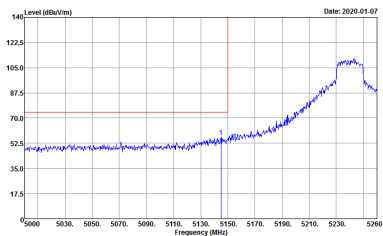
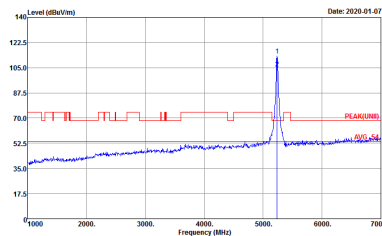
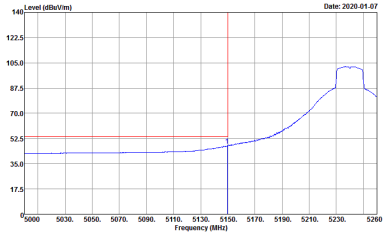

WIFI	Band 1 5150~5250MHz Band Edge @ 3m	
ANT	802.11ax HE20 CH48 5240MHz - L	
1+2	Horizontal	Fundamental
<p>Peak</p>	 <p>Date: 2020-01-07</p> <p>Site : 03CH13-HY Condition : PEAK_BE_74 3m HORN_9120D_1241 HORIZONTAL RBW:1000.000KHz VBW:3000.000KHz SWT:Auto Detector : Peak Project : 9D0635</p>	 <p>Date: 2020-01-07</p> <p>Site : 03CH13-HY Condition : PEAK(UNIT) 3m HORN_9120D_1241 HORIZONTAL RBW:1000.000KHz VBW:3000.000KHz SWT:Auto Detector : Peak Project : 9D0635</p>
<p>Avg.</p>	 <p>Date: 2020-01-07</p> <p>Site : 03CH13-HY Condition : AVG_BE_54 3m HORN_9120D_1241 HORIZONTAL RBW:1000.000KHz VBW:0.010KHz SWT:Auto Detector : Peak Project : 9D0635</p>	<p>Left blank</p>

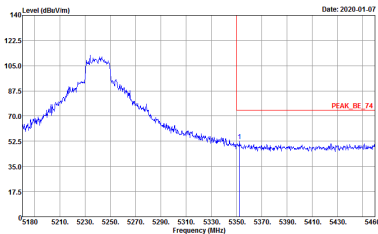
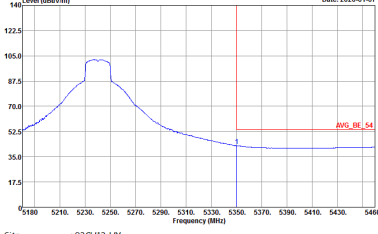

WIFI	Band 1 5150~5250MHz Band Edge @ 3m	
ANT	802.11ax HE20 CH48 5240MHz - R	
1+2	Horizontal	Fundamental
<p>Peak</p>	 <p>Site : 03CH13-HY Condition : PEAK_BE_74 3m HORN_91200_1241 HORIZONTAL Detector : Peak Project : 9D0635</p>	<p>Left blank</p>
<p>Avg.</p>	 <p>Site : 03CH13-HY Condition : AVG_BE_54 3m HORN_91200_1241 HORIZONTAL Detector : Peak Project : 9D0635</p>	<p>Left blank</p>

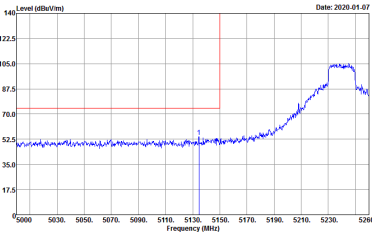
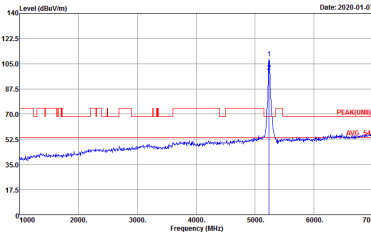
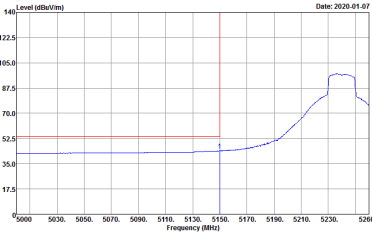

WIFI	Band 1 5150~5250MHz Band Edge @ 3m	
ANT	802.11ax HE20 CH48 5240MHz - L	
1+2	Vertical	Fundamental
Peak	 <p>Date: 2020-01-07</p> <p>Site : 03CH13-HY Condition : PEAK_BE_74 3m HORN_9120D_1241 VERTICAL RBW:1000.000KHz VBW:3000.000KHz SWT:Auto Detector : Peak Project : 9D0635</p>	 <p>Date: 2020-01-07</p> <p>Site : 03CH13-HY Condition : PEAK(UNIT) 3m HORN_9120D_1241 VERTICAL RBW:1000.000KHz VBW:3000.000KHz SWT:Auto Detector : Peak Project : 9D0635</p>
Avg.	 <p>Date: 2020-01-07</p> <p>Site : 03CH13-HY Condition : AVG_BE_54 3m HORN_9120D_1241 VERTICAL RBW:1000.000KHz VBW:0.010KHz SWT:Auto Detector : Peak Project : 9D0635</p>	Left blank

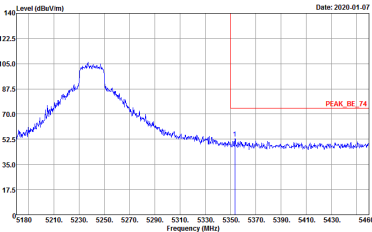
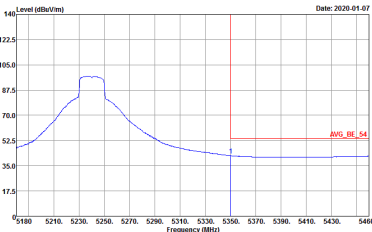

WIFI	Band 1 5150~5250MHz Band Edge @ 3m	
ANT	802.11ax HE20 CH48 5240MHz - R	
1+2	Vertical	Fundamental
<p>Peak</p>	 <p>Site : 03CH13-HY Condition : PEAK_BE_74 3m HORN_91200_1241 VERTICAL Detector : Peak Project : 9D0635</p>	<p>Left blank</p>
<p>Avg.</p>	 <p>Site : 03CH13-HY Condition : AVG_BE_54 3m HORN_91200_1241 VERTICAL Detector : Peak Project : 9D0635</p>	<p>Left blank</p>

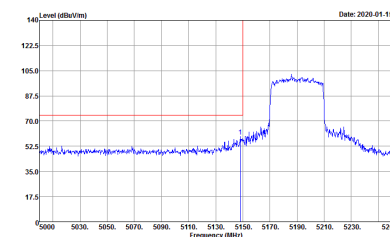
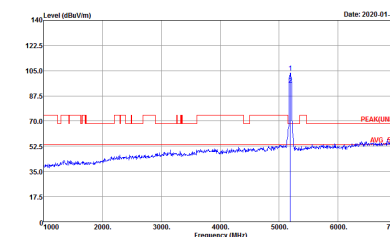
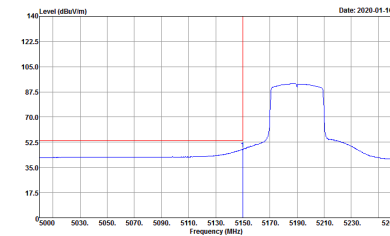

Band 1 5150~5250MHz
WIFI 802.11ax HE40 (Band Edge @ 3m)

WIFI	Band 1 5150~5250MHz Band Edge @ 3m	
ANT	802.11ax HE40 CH38 5190MHz - L	
1+2	Horizontal	Fundamental
<p align="center">Peak</p>	 <p> Site : 03CH13-HY Condition : PEAK_BE_74 3m HORN_91200_1241 HORIZONTAL Detector : Peak Project : 9D0635 Setting : 17 </p>	 <p> Site : 03CH13-HY Condition : PEAK(LINE) 3m HORN_91200_1241 HORIZONTAL Detector : Peak Project : 9D0635 Setting : 17 </p>
<p align="center">Avg.</p>	 <p> Site : 03CH13-HY Condition : AVG_BE_54 3m HORN_91200_1241 HORIZONTAL Detector : Peak Project : 9D0635 Setting : 17 </p>	<p align="center">Left blank</p>

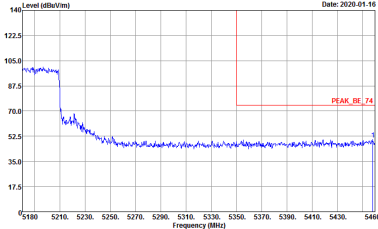
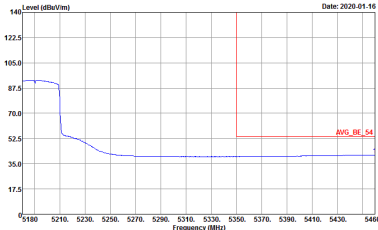

WIFI	Band 1 5150~5250MHz Band Edge @ 3m	
ANT	802.11ax HE40 CH38 5190MHz - R	
1+2	Horizontal	Fundamental
<p>Peak</p>	 <p>Site : 03CH13-HY Condition : PEAK_BE_74 3m HORN_91200_1241 HORIZONTAL Detector : Peak Project : 9D0635 Setting : 17</p>	<p>Left blank</p>
<p>Avg.</p>	 <p>Site : 03CH13-HY Condition : AVG_BE_54 3m HORN_91200_1241 HORIZONTAL Detector : Peak Project : 9D0635 Setting : 17</p>	<p>Left blank</p>

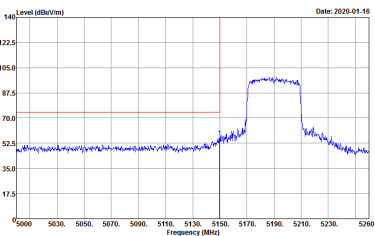
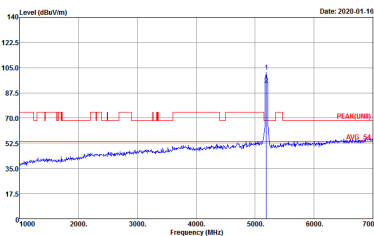
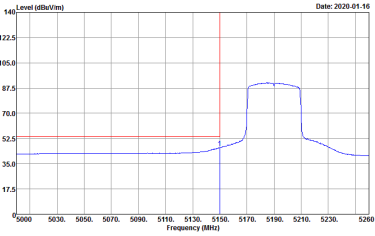

WIFI	Band 1 5150~5250MHz Band Edge @ 3m	
ANT	802.11ax HE40 CH38 5190MHz - L	
1+2	Vertical	Fundamental
Peak	 <p>Date: 2020-01-16</p> <p>Site : 03CH13-HY Condition : PEAK_BE_74 3m HORN_9120D_1241 VERTICAL RBW:1000.000KHz VBW:3000.000KHz SWT:Auto Detector : Peak Project : 9D0635 Setting : 17</p>	 <p>Date: 2020-01-16</p> <p>Site : 03CH13-HY Condition : PEAK(UNIT) 3m HORN_9120D_1241 VERTICAL RBW:1000.000KHz VBW:3000.000KHz SWT:Auto Detector : Peak Project : 9D0635 Setting : 17</p>
Avg.	 <p>Date: 2020-01-16</p> <p>Site : 03CH13-HY Condition : AVG_BE_54 3m HORN_9120D_1241 VERTICAL RBW:1000.000KHz VBW:0.010KHz SWT:Auto Detector : Peak Project : 9D0635 Setting : 17</p>	Left blank

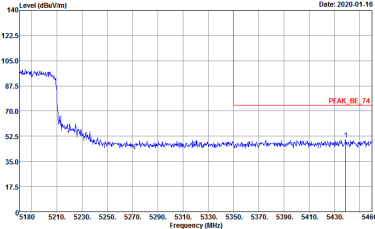
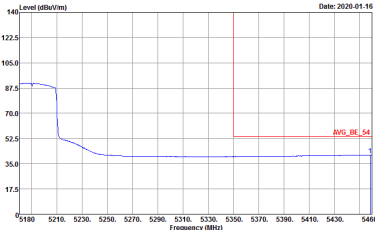

WIFI	Band 1 5150~5250MHz Band Edge @ 3m	
ANT	802.11ax HE40 CH38 5190MHz - R	
1+2	Vertical	Fundamental
<p>Peak</p>	 <p>Date: 2020-01-16</p> <p>Site : 03CH13-HY Condition : PEAK_BE_74 3m HORN_91200_1241 VERTICAL : RBW:1000.000KHz VBW:3000.000KHz SWT:Auto Detector : Peak Project : 9D0635 Setting : 17</p>	<p>Left blank</p>
<p>Avg.</p>	 <p>Date: 2020-01-16</p> <p>Site : 03CH13-HY Condition : AVG_BE_54 3m HORN_91200_1241 VERTICAL : RBW:1000.000KHz VBW:0.010KHz SWT:Auto Detector : Peak Project : 9D0635 Setting : 17</p>	<p>Left blank</p>



WIFI	Band 1 5150~5250MHz Band Edge @ 3m	
ANT	802.11ax HE40 CH46 5230MHz - L	
1+2	Horizontal	Fundamental
<p>Peak</p>	<p>Site : 03CH13-HY Condition : PEAK_BE_74 3m HORN_9120D_1241 HORIZONTAL Detector : Peak Project : 9D0635 Setting : 20</p>	<p>Site : 03CH13-HY Condition : PEAK(UNIT) 3m HORN_9120D_1241 HORIZONTAL Detector : Peak Project : 9D0635 Setting : 20</p>
<p>Avg.</p>	<p>Site : 03CH13-HY Condition : AVG_BE_54 3m HORN_9120D_1241 HORIZONTAL Detector : Peak Project : 9D0635 Setting : 20</p>	<p>Left blank</p>

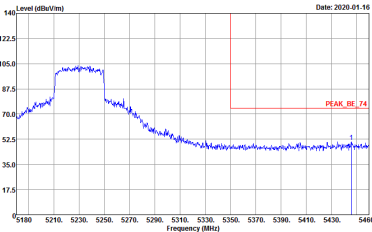
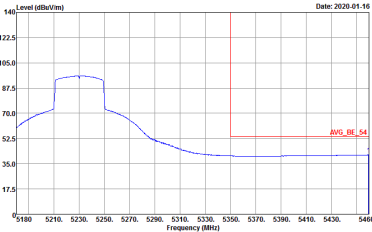

WIFI	Band 1 5150~5250MHz Band Edge @ 3m	
ANT	802.11ax HE40 CH46 5230MHz - R	
1+2	Horizontal	Fundamental
<p>Peak</p>	 <p>Site : 03CH13-HY Condition : PEAK_BE_74 3m HORN_91200_1241 HORIZONTAL Detector : Peak Project : 9D0635 Setting : 20</p>	<p>Left blank</p>
<p>Avg.</p>	 <p>Site : 03CH13-HY Condition : AVG_BE_54 3m HORN_91200_1241 HORIZONTAL Detector : Peak Project : 9D0635 Setting : 20</p>	<p>Left blank</p>

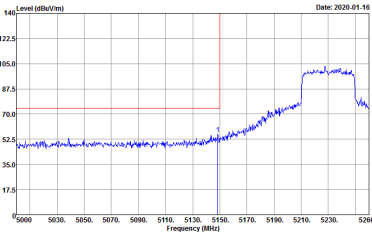
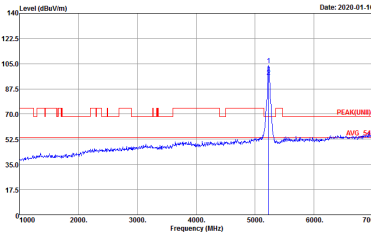
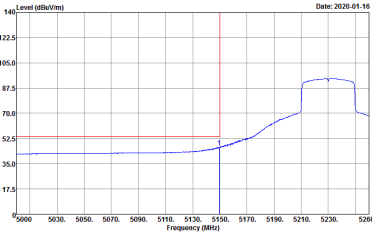

WIFI	Band 1 5150~5250MHz Band Edge @ 3m	
ANT	802.11ax HE40 CH46 5230MHz - L	
1+2	Vertical	Fundamental
<p>Peak</p>	 <p>Date: 2020-01-16</p> <p>Site : 03CH13-HY Condition : PEAK_BE_74 3m HORN_9120D_1241 VERTICAL RBW:1000.000KHz VBW:3000.000KHz SWT:Auto Detector : Peak Project : 9D0635 Setting : 20</p>	 <p>Date: 2020-01-16</p> <p>Site : 03CH13-HY Condition : PEAK(UNIT) 3m HORN_9120D_1241 VERTICAL RBW:1000.000KHz VBW:3000.000KHz SWT:Auto Detector : Peak Project : 9D0635 Setting : 20</p>
<p>Avg.</p>	 <p>Date: 2020-01-16</p> <p>Site : 03CH13-HY Condition : AVG_BE_54 3m HORN_9120D_1241 VERTICAL RBW:1000.000KHz VBW:0.010KHz SWT:Auto Detector : Peak Project : 9D0635 Setting : 20</p>	<p>Left blank</p>

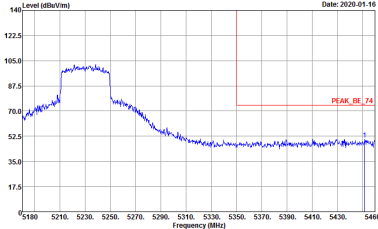
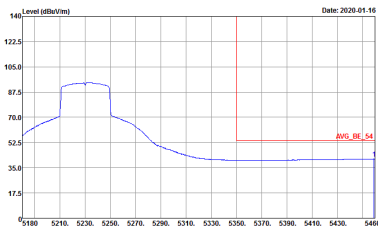

WIFI	Band 1 5150~5250MHz Band Edge @ 3m	
ANT	802.11ax HE40 CH46 5230MHz - R	
1+2	Vertical	Fundamental
<p>Peak</p>	 <p>Site : 03CH13-HY Condition : PEAK_BE_74 3m HORN_91200_1241 VERTICAL Detector : Peak Project : 9D0635 Setting : 20</p>	<p>Left blank</p>
<p>Avg.</p>	 <p>Site : 03CH13-HY Condition : AVG_BE_54 3m HORN_91200_1241 VERTICAL Detector : Peak Project : 9D0635 Setting : 20</p>	<p>Left blank</p>

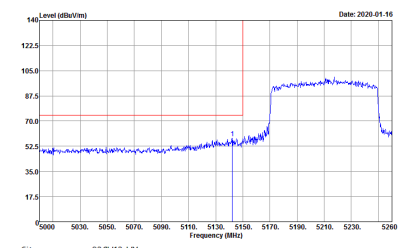
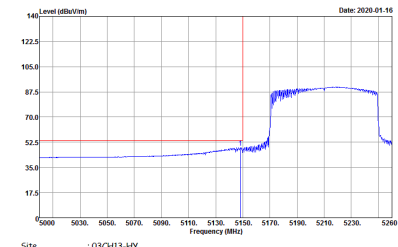

Band 1 5150~5250MHz
WIFI 802.11ax HE80 (Band Edge @ 3m)

WIFI	Band 1 5150~5250MHz Band Edge @ 3m	
ANT	802.11ax HE80 CH42 5210MHz - L	
1+2	Horizontal	Fundamental
<p align="center">Peak</p>	 <p>Site : 03CH13-HY Condition : PEAK_BE_74 3m HORN_91200_1241 HORIZONTAL Detector : Peak Project : 9D0635 Setting : 17</p>	 <p>Site : 03CH13-HY Condition : PEAK(LINE) 3m HORN_91200_1241 HORIZONTAL Detector : Peak Project : 9D0635 Setting : 17</p>
<p align="center">Avg.</p>	 <p>Site : 03CH13-HY Condition : AVG_BE_54 3m HORN_91200_1241 HORIZONTAL Detector : Peak Project : 9D0635 Setting : 17</p>	<p align="center">Left blank</p>

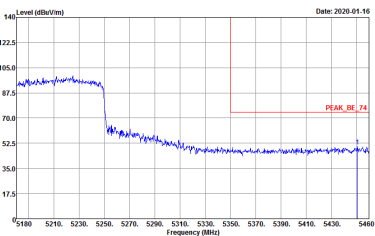
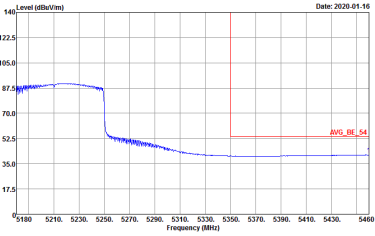

WIFI	Band 1 5150~5250MHz Band Edge @ 3m	
ANT	802.11ax HE80 CH42 5210MHz - R	
1+2	Horizontal	Fundamental
<p>Peak</p>	 <p>Date: 2020-01-16</p> <p>Site : 03CH13-HY Condition : PEAK_BE_74 3m HORN_91200_1241 HORIZONTAL RBW:1000.000KHz VBW:3000.000KHz SWT:Auto Detector : Peak Project : 9D0635 Setting : 17</p>	<p>Left blank</p>
<p>Avg.</p>	 <p>Date: 2020-01-16</p> <p>Site : 03CH13-HY Condition : AVG_BE_54 3m HORN_91200_1241 HORIZONTAL RBW:1000.000KHz VBW:0.010KHz SWT:Auto Detector : Peak Project : 9D0635 Setting : 17</p>	<p>Left blank</p>

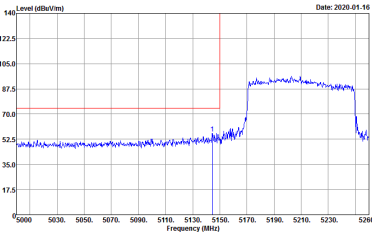
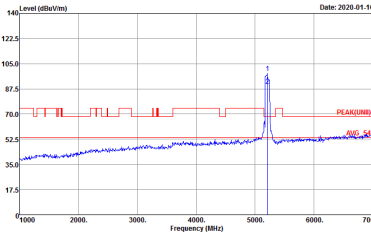
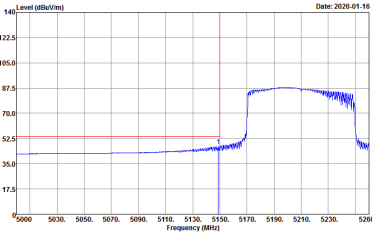

WIFI	Band 1 5150~5250MHz Band Edge @ 3m	
ANT	802.11ax HE80 CH42 5210MHz - L	
1+2	Vertical	Fundamental
<p>Peak</p>	 <p>Site : 03CH13-HY Condition : PEAK_BE_74 3m HORN_9120D_1241 VERTICAL Detector : Peak Project : 9D0635 Setting : 17</p>	 <p>Site : 03CH13-HY Condition : PEAK(UNIT) 3m HORN_9120D_1241 VERTICAL Detector : Peak Project : 9D0635 Setting : 17</p>
<p>Avg.</p>	 <p>Site : 03CH13-HY Condition : AVG_BE_54 3m HORN_9120D_1241 VERTICAL Detector : Peak Project : 9D0635 Setting : 17</p>	<p>Left blank</p>



WIFI	Band 1 5150~5250MHz Band Edge @ 3m	
ANT	802.11ax HE80 CH42 5210MHz - R	
1+2	Vertical	Fundamental
<p>Peak</p>		<p>Left blank</p>
<p>Avg.</p>		<p>Left blank</p>



Band 1 5150~5250MHz

WIFI 802.11ax HE20 (Partial RU 26/0) (Band Edge @ 3m)

WIFI	Band 1 5150~5250MHz Band Edge @ 3m	
ANT	802.11ax HE20 CH36 5180MHz	
1+2	Horizontal	Fundamental
Peak	<p>Site : 03CH13-HY Condition : PEAK_BE_74 3m HORN_9120D_1241 HORIZONTAL RBW:1000.000kHz VBW:3000.000kHz SWT:Auto Detector : Peak Project : 9D0635</p>	<p>Site : 03CH13-HY Condition : PEAK(UNI) 3m HORN_9120D_1241 HORIZONTAL RBW:1000.000kHz VBW:3000.000kHz SWT:Auto Detector : Peak Project : 9D0635</p>
Avg.	<p>Site : 03CH13-HY Condition : AVG_BE_54 3m HORN_9120D_1241 HORIZONTAL RBW:1000.000kHz VBW:0.010kHz SWT:Auto Detector : Peak Project : 9D0635</p>	Left blank



WIFI	Band 1 5150~5250MHz Band Edge @ 3m	
ANT	802.11ax HE20 CH36 5180MHz	
1+2	Vertical	Fundamental
<p>Peak</p>	<p>Site : 03CH13-HY Condition : PEAK_BE_74 3m HORN_9120D_1241 VERTICAL RBW:1000.000kHz VBW:3000.000kHz SWT:Auto Detector : Peak Project : 9D0635</p>	<p>Site : 03CH13-HY Condition : PEAK(UNII) 3m HORN_9120D_1241 VERTICAL RBW:1000.000kHz VBW:3000.000kHz SWT:Auto Detector : Peak Project : 9D0635</p>
<p>Avg.</p>	<p>Site : 03CH13-HY Condition : AVG_BE_54 3m HORN_9120D_1241 VERTICAL RBW:1000.000kHz VBW:0.0100kHz SWT:Auto Detector : Peak Project : 9D0635</p>	<p>Left blank</p>



Band 1 5150~5250MHz

WIFI 802.11ax HE20 (Partial RU 52/37) (Band Edge @ 3m)

WIFI	Band 1 5150~5250MHz Band Edge @ 3m	
ANT	802.11ax HE20 CH36 5180MHz	
1+2	Horizontal	Fundamental
Peak	<p>Site : 03CH13-HY Condition : PEAK_BE_74 3m HORN_9120D_1241 HORIZONTAL RBW:1000.000kHz VBW:3000.000kHz SWT:Auto Detector : Peak Project : 9D0635</p>	<p>Site : 03CH13-HY Condition : PEAK(UNI) 3m HORN_9120D_1241 HORIZONTAL RBW:1000.000kHz VBW:3000.000kHz SWT:Auto Detector : Peak Project : 9D0635</p>
Avg.	<p>Site : 03CH13-HY Condition : AVG_BE_54 3m HORN_9120D_1241 HORIZONTAL RBW:1000.000kHz VBW:0.010kHz SWT:Auto Detector : Peak Project : 9D0635</p>	Left blank



WIFI	Band 1 5150~5250MHz Band Edge @ 3m	
ANT	802.11ax HE20 CH36 5180MHz	
1+2	Vertical	Fundamental
Peak	<p>Site : 03CH13-HY Condition : PEAK_BE_74 3m HORN_9120D_1241 VERTICAL RBW:1000.000kHz VBW:3000.000kHz SWT:Auto Detector : Peak Project : 9D0635</p>	<p>Site : 03CH13-HY Condition : PEAK(UNI) 3m HORN_9120D_1241 VERTICAL RBW:1000.000kHz VBW:3000.000kHz SWT:Auto Detector : Peak Project : 9D0635</p>
Avg.	<p>Site : 03CH13-HY Condition : AVG_BE_54 3m HORN_9120D_1241 VERTICAL RBW:1000.000kHz VBW:0.0100kHz SWT:Auto Detector : Peak Project : 9D0635</p>	Left blank