



FCC CO-LOCATION RADIO TEST REPORT

FCC ID : IHDT56YJ1
Equipment : Mobile Cellular Phone
Brand Name : Motorola
Model Name : XT2061-1
Applicant : Motorola Mobility, LLC
222 W Merchandise Mart Plaza, Suite
1800, Chicago, IL 60654, United States
Manufacturer : Motorola Mobility, LLC
222 W Merchandise Mart Plaza, Suite
1800, Chicago, IL 60654, United States
Standard : FCC Part 15 Subpart E §15.407

The product was received on Dec. 06, 2019 and testing was started from Jan. 27, 2020 and completed on Feb. 09, 2020. We, SPORTON INTERNATIONAL INC., EMC & Wireless Communications Laboratory, would like to declare that the tested sample has been evaluated in accordance with the test procedures and has been in compliance with the applicable technical standards.

The report must not be used by the client to claim product certification, approval, or endorsement by TAF or any agency of government.

The test results in this report apply exclusively to the tested model / sample. Without written approval of SPORTON INTERNATIONAL INC. EMC & Wireless Communications Laboratory, the test report shall not be reproduced except in full.

Approved by: Louis Wu

SPORTON INTERNATIONAL INC. EMC & Wireless Communications Laboratory
No. 52, Huaya 1st Rd., Guishan Dist., Taoyuan City, Taiwan (R.O.C.)



Table of Contents

History of this test report..... 3

Summary of Test Result..... 4

1 General Description 5

 1.1 Product Feature of Equipment Under Test..... 5

 1.2 Product Specification of Equipment Under Test..... 6

 1.3 Modification of EUT 6

 1.4 Testing Location 7

 1.5 Applicable Standards..... 7

2 Test Configuration of Equipment Under Test 8

 2.1 Carrier Frequency and Channel 8

 2.2 Test Mode..... 8

 2.3 Connection Diagram of Test System..... 9

 2.4 Support Unit used in test configuration and system 10

 2.5 EUT Operation Test Setup 10

3 Test Result 11

 3.1 Unwanted Emissions Measurement..... 11

 3.2 Antenna Requirements..... 15

4 List of Measuring Equipment..... 16

5 Uncertainty of Evaluation..... 17

Appendix A. Radiated Spurious Emission

Appendix B. Radiated Spurious Emission Plots

Appendix C. Duty Cycle Plots



Summary of Test Result

Report Clause	Ref Std. Clause	Test Items	Result (PASS/FAIL)	Remark
3.1	15.407(b)	Unwanted Emissions	Pass	Under limit 3.30 dB at 2390.000 MHz
3.2	15.203 15.407(a)	Antenna Requirement	Pass	-

Declaration of Conformity: The test results with all measurement uncertainty excluded are presented in accordance with the regulation limits or requirements declared by manufacturers.
Comments and Explanations: The declared of product specification for EUT presented in the report are provided by the manufacturer, and the manufacturer takes all the responsibilities for the accuracy of product specification.

Reviewed by: Wii Chang
Report Producer: Yvonne Cheng



1 General Description

1.1 Product Feature of Equipment Under Test

Product Feature	
Equipment	Mobile Cellular Phone
Brand Name	Motorola
Model Name	XT2061-1
FCC ID	IHDT56YJ1
IMEI Code	IMEI: 359120100017048
EUT supports Radios application	CDMA/EV-DO/GSM/EGPRS/WCDMA/HSPA/LTE/5G NR/ GNSS/NFC/WPC WLAN 11b/g/n HT20 WLAN 11a/n HT20/HT40 WLAN 11ac VHT20/VHT40/VHT80 WLAN 11ax HE20/HE40/HE80 Bluetooth BR/EDR/LE
HW Version	DVT2
EUT Stage	Identical Prototype

Remark: The above EUT's information was declared by manufacturer.

Accessory List	
AC Adapter 1	Brand Name : Motorola
	Model Name : SC-51 (SA18C30116)
	Manufacturer : Chenyang
AC Adapter 2	Brand Name : Motorola
	Model Name : SC-51 (SA18C62985)
	Manufacturer : Acbel
Battery	Brand Name : ATL
	Model Name : LW50
USB Cable 1	Brand Name : Motorola
	Model Name : SC18C24367
	Manufacturer : Saibao
USB Cable 2	Brand Name : Motorola
	Model Name : SC18C24368
	Manufacturer : Luxshare

1.2 Product Specification of Equipment Under Test

Standards-related Product Specification	
Tx/Rx Frequency Range	5180 MHz ~ 5240 MHz 5260 MHz ~ 5320 MHz 5500 MHz ~ 5720 MHz
Type of Modulation	802.11a/n : OFDM (BPSK / QPSK / 16QAM / 64QAM) 802.11ac : OFDM (BPSK / QPSK / 16QAM / 64QAM / 256QAM) 802.11ax: OFDM (BPSK / QPSK / 16QAM / 64QAM / 256QAM / 1024QAM)
Antenna Type / Gain	Bluetooth: ILA Antenna type with gain -2.50 dBi <2412 MHz ~ 2462 MHz> Ant. 1: Fixed Internal type with gain -2.50 dBi Ant. 2: Fixed Internal type with gain -6.60 dBi <5180 MHz ~ 5240 MHz> Ant. 1 : ILA Antenna with gain 1.50 dBi Ant. 2 : ILA Antenna with gain 1.30 dBi

1.3 Modification of EUT

No modifications are made to the EUT during all test items.



1.4 Testing Location

Test Site	SPORTON INTERNATIONAL INC. EMC & Wireless Communications Laboratory
Test Site Location	No.58, Aly. 75, Ln. 564, Wenhua 3rd, Rd., Guishan Dist., Taoyuan City, Taiwan (R.O.C.) TEL: +886-3-327-0868 FAX: +886-3-327-0855
Test Site No.	Sporton Site No. 03CH15-HY

Note: The test site complies with ANSI C63.4 2014 requirement.

FCC designation No.: TW0007

1.5 Applicable Standards

According to the specifications of the manufacturer, the EUT must comply with the requirements of the following standards:

- ♦ FCC Part 15 Subpart E
- ♦ FCC KDB 789033 D02 General UNII Test Procedures New Rules v02r01.
- ♦ FCC KDB Publication No. 558074 D01 DTS Meas. Guidance v05r02
- ♦ FCC KDB 971168 D01 Power Meas. License Digital Systems v03r01
- ♦ FCC KDB 414788 D01 Radiated Test Site v01r01.
- ♦ FCC KDB 662911 D01 Multiple Transmitter Output v02r01.
- ♦ ANSI C63.10-2013

Remark:

1. All test items were verified and recorded according to the standards and without any deviation during the test.
2. This EUT has also been tested and complied with the requirements of FCC Part 15, Subpart B, recorded in a separate test report.



2 Test Configuration of Equipment Under Test

- a. The EUT has been associated with peripherals and configuration operated in a manner tended to maximize its emission characteristics in a typical application. Frequency range investigated: radiation emission (9 kHz to the 10th harmonic of the highest fundamental frequency or to 40 GHz, whichever is lower). For radiated measurement, pre-scanned in three orthogonal panels, X, Y, Z. The worst cases (Y Plane for BLE + 2.4GHz 802.11ax Mode, BLE + 5GHz 802.11ax Mode, and LTE Band 7 + 2.4GHz 802.11ax Mode; Z Plane for BT + 2.4GHz 802.11ax + 5GHz 802.11ax Mode) were recorded in this report.

2.1 Carrier Frequency and Channel

2400-2483.5 MHz Bluetooth		2400-2483.5 MHz Bluetooth - LE	
Channel	Freq. (MHz)	Channel	Freq. (MHz)
78	2480	00	2402

2400-2483.5 MHz 802.11ax		5150-5250 MHz 802.11ac	
Channel	Freq. (MHz)	Channel	Channel
01	2412	36	5180

Remark: During the Radiated Spurious Emission test, the EUT turn on the WWAN functions simultaneously.

2.2 Test Mode

Final test modes are considering the modulation and worse data rates as below table.

<Co-Location>

Modulation	Data Rate
Bluetooth + 2.4GHz 802.11ax	1Mbps + MCS0
Bluetooth-LE + 2.4GHz 802.11ax	2Mbps + MCS0
Bluetooth + 5GHz 802.11ax	1Mbps + MCS0
Bluetooth-LE + 5GHz 802.11ax	2Mbps + MCS0
2.4GHz 802.11ax + 5GHz 802.11ax	MCS0 + MCS0
Bluetooth + 2.4GHz 802.11ax + 5GHz 802.11ax	1Mbps + MCS0 + MCS0
Bluetooth-LE + 2.4GHz 802.11ax + 5GHz 802.11ax	2Mbps + MCS0 + MCS0
LTE + 2.4GHz 802.11ax	QPSK + MCS0

2.3 Connection Diagram of Test System

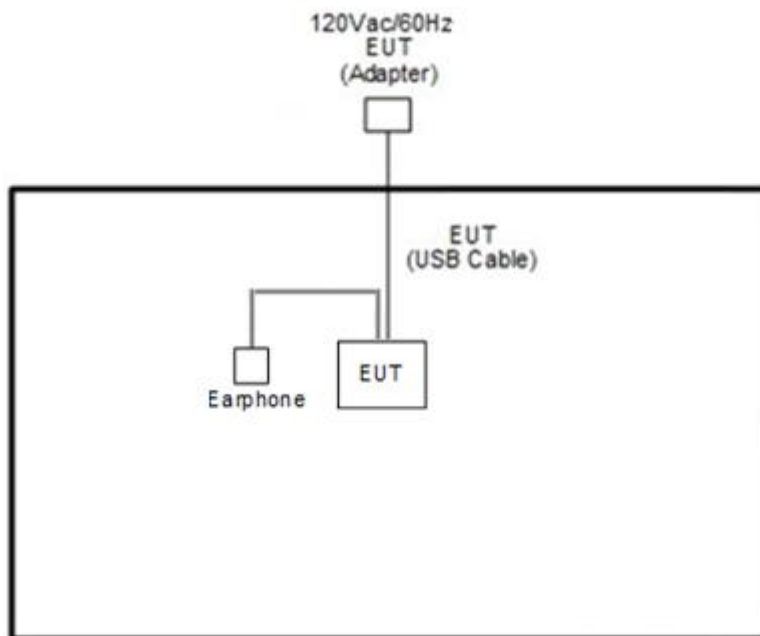
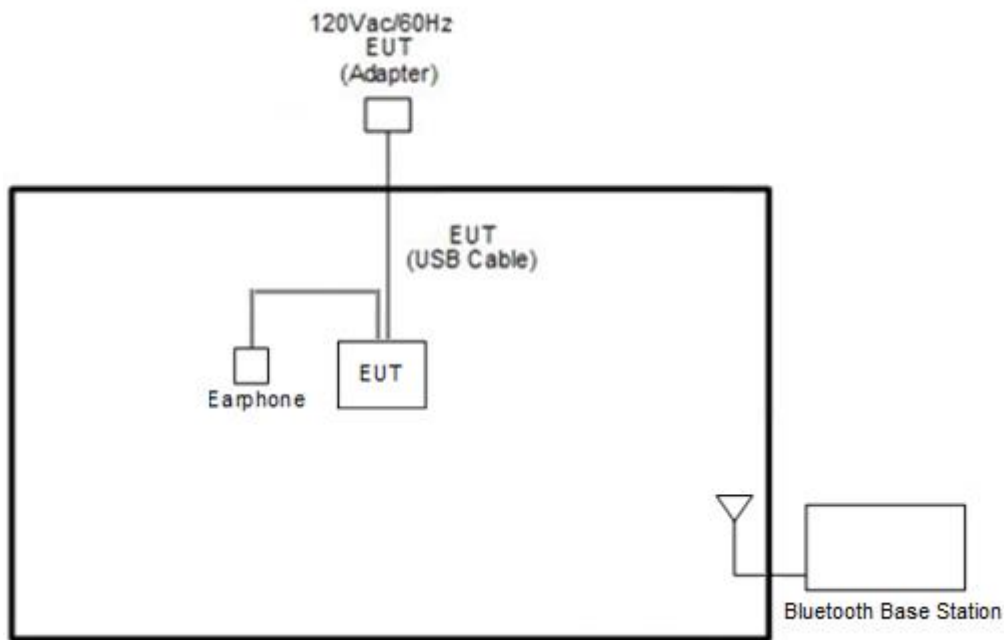

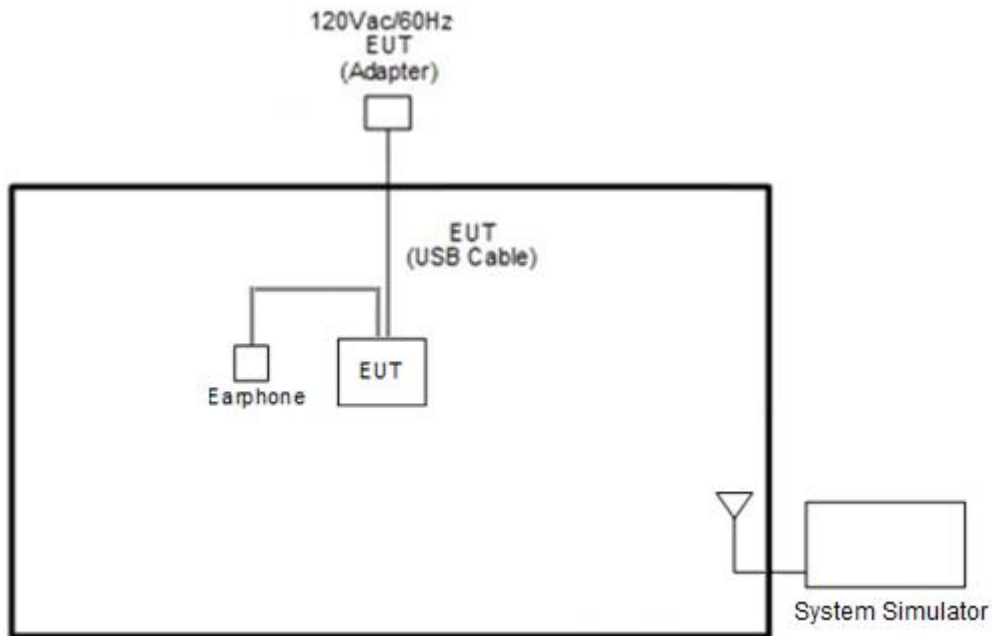

2.4 Support Unit used in test configuration and system

Item	Equipment	Trade Name	Model Name	FCC ID	Data Cable	Power Cord
1.	Bluetooth Base Station	R&S	CBT32	N/A	N/A	Unshielded, 1.8 m
2.	LTE Base Station	Anritsu	MT8820C	N/A	N/A	Unshielded, 1.8 m

2.5 EUT Operation Test Setup

The RF test items, utility “QRCT v4.0.00142.0” was installed in Notebook which was programmed in order to make the EUT get into the engineering modes to provide channel selection, power level, data rate and the application type and for continuous transmitting signals.

The RF test items, utility “QRCT v4.0.00142.0” was installed in Notebook which was programmed in order to make the EUT get into the engineering modes to contact with base station to provide channel selection, power level, data rate and the application type and for continuous transmitting signals.



3 Test Result

3.1 Unwanted Emissions Measurement

3.1.1 Limit of Unwanted Emissions

(1) Unwanted spurious emissions fallen in restricted bands shall comply with the general field strength limits as below table:

Frequency (MHz)	Field Strength (microvolts/meter)	Measurement Distance (meters)
0.009 – 0.490	2400/F(kHz)	300
0.490 – 1.705	24000/F(kHz)	30
1.705 – 30.0	30	30
30 – 88	100	3
88 – 216	150	3
216 - 960	200	3
Above 960	500	3

Note: The following formula is used to convert the EIRP to field strength.

$$E = \frac{1000000\sqrt{30P}}{3} \mu\text{V/m, where P is the eirp (Watts)}$$

EIRP (dBm)	Field Strength at 3m (dBμV/m)
- 27	68.3

(2) KDB789033 D02 v02r01 G)2)c)

- (i) Sections 15.407(b)(1-3) specifies the unwanted emissions limit for the U-NII-1 and U-NII-2 bands. As specified, emissions above 1000 MHz that are outside of the restricted bands are subject to a peak emission limit of -27 dBm/MHz.
- (ii) Section 15.407(b)(4) specifies the unwanted emissions limit for the U-NII-3 band. A band emissions mask is specified in Section 15.407(b)(4)(i). The emission limits are based on the use of a peak detector.

3.1.2 Measuring Instruments

See list of measuring equipment of this test report.



3.1.3 Test Procedures

1. The testing follows FCC KDB 789033 D02 General UNII Test Procedures New Rules v02r01. Section G) Unwanted emissions measurement.
 - (1) Procedure for Unwanted Emissions Measurements Below 1000MHz
 - RBW = 120 kHz
 - VBW = 300 kHz
 - Detector = Peak
 - Trace mode = max hold
 - (2) Procedure for Peak Unwanted Emissions Measurements Above 1000 MHz
 - RBW = 1 MHz
 - VBW \geq 3 MHz
 - Detector = Peak
 - Sweep time = auto
 - Trace mode = max hold
 - (3) Procedures for Average Unwanted Emissions Measurements Above 1000MHz
 - RBW = 1 MHz
 - VBW = 10 Hz, when duty cycle is no less than 98 percent.
 - VBW \geq 1/T, when duty cycle is less than 98 percent where T is the minimum transmission duration over which the transmitter is on and is transmitting at its maximum power control level for the tested mode of operation.
2. The EUT was placed on a turntable with 0.8 meter for frequency below 1GHz and 1.5 meter for frequency above 1GHz respectively above ground.
3. The EUT was set 3 meters from the interference receiving antenna which was mounted on the top of a variable height antenna tower.
4. The antenna is a broadband antenna and its height is adjusted between one meter and four meters above ground to find the maximum value of the field strength for both horizontal polarization and vertical polarization of the antenna.
5. For each suspected emission, the EUT was arranged to its worst case and then adjust the antenna tower (from 1 m to 4 m) and turntable (from 0 degree to 360 degrees) to find the maximum reading.
6. For testing below 1GHz, if the emission level of the EUT in peak mode was 3 dB lower than the limit specified, then peak values of EUT will be reported, otherwise, the emissions will be repeated one by one using the CISPR quasi-peak method and reported.
7. For testing above 1GHz, the emission level of the EUT in peak mode was 20dB lower than average limit (that means the emission level in average mode also complies with the limit in average mode), then peak values of EUT will be reported, otherwise, the emissions will be measured in average mode again and reported.

3.1.4 Test Setup

For radiated emissions below 30MHz

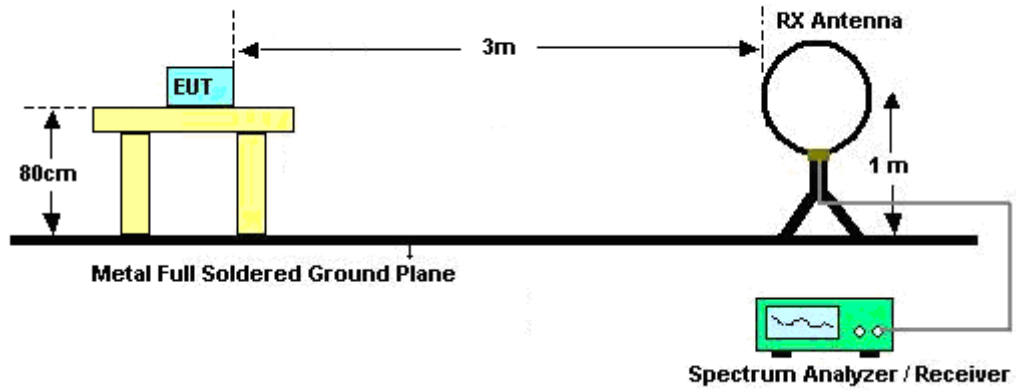

For radiated emissions from 30MHz to 1GHz

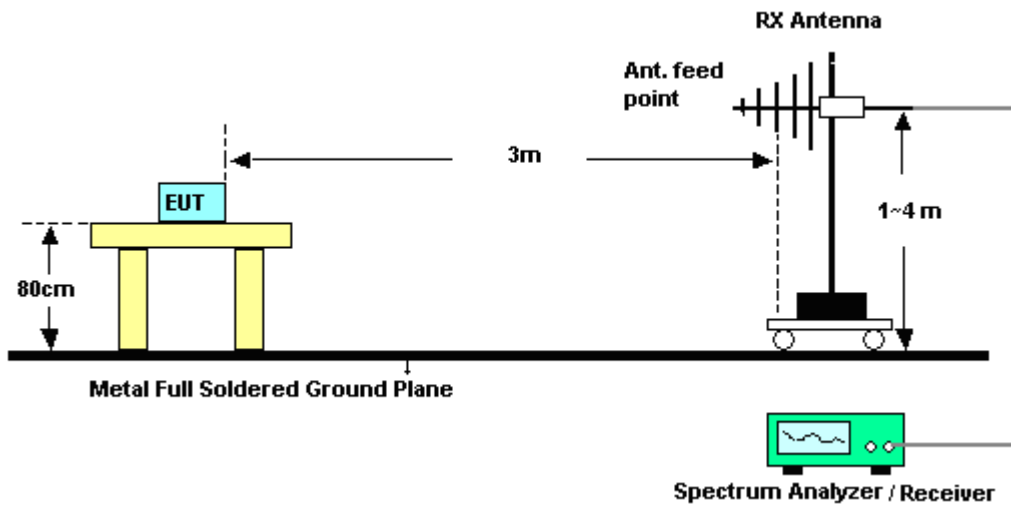

For radiated emissions above 1GHz

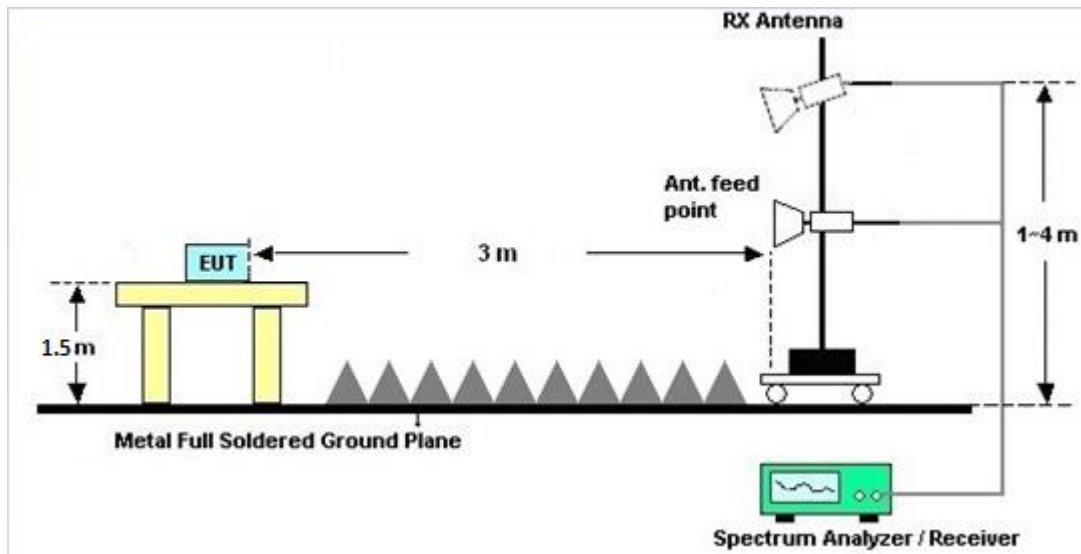

3.1.5 Test Results of Radiated Spurious Emissions (9 kHz ~ 30 MHz)

The low frequency, which started from 9 kHz to 30MHz, was pre-scanned and the result which was 20dB lower than the limit line was not reported.

There is a comparison data of both open-field test site and alternative test site - semi-Anechoic chamber according to 414788 D01 Radiated Test Site v01r01, and the result came out very similar.

3.1.6 Test Result of Radiated Spurious at Band Edges

Please refer to Appendix A and B.

3.1.7 Duty Cycle

Please refer to Appendix C.

3.1.8 Test Result of Radiated Spurious Emissions (30MHz ~ 10th Harmonic)

Please refer to Appendix A and B.



3.2 Antenna Requirements

3.2.1 Standard Applicable

If transmitting antenna directional gain is greater than 6 dBi, both the peak transmit power and the peak power spectral density shall be reduced by the amount in dB that the directional gain of the antenna exceeds 6 dBi.

3.2.2 Antenna Anti-Replacement Construction

An embedded-in antenna design is used.

3.2.3 Antenna Gain

The antenna peak gain of EUT is less than 6 dBi. Therefore, it is not necessary to reduce maximum peak output power limit.



4 List of Measuring Equipment

Instrument	Manufacturer	Model No.	Serial No.	Characteristics	Calibration Date	Test Date	Due Date	Remark
Preamplifier	EMEC INSTRUMENT S&PE	EMC184045B &PE7005-6	980192	18GHz ~ 40GHz	Aug. 01, 2019	Jan. 27, 2020~ Feb. 09, 2020	Jul. 31, 2020	Radiation (03CH15-HY)
Horn Antenna	SCHWARZBECK	BBHA 9120 D	9120D-1620	1-18GHz	Oct. 28, 2019	Jan. 27, 2020~ Feb. 09, 2020	Oct. 27, 2020	Radiation (03CH15-HY)
SHF-EHF Horn Antenna	SCHWARZBECK	BBHA 9170	BBHA9170576	18GHz~40GHz	May 14, 2019	Jan. 27, 2020~ Feb. 09, 2020	May 13, 2020	Radiation (03CH15-HY)
Preamplifier	Jet-Power	JPA0118-55-303	1710001800055007	1GHz~18GHz	Apr. 01, 2019	Jan. 27, 2020~ Feb. 09, 2020	May 31, 2020	Radiation (03CH15-HY)
Preamplifier	Keysight	83017A	MY53270195	1GHz~26.5GHz	Aug. 23, 2019	Jan. 27, 2020~ Feb. 09, 2020	Aug. 22, 2020	Radiation (03CH15-HY)
EMI Test Receiver	Keysight	N9038A(MXE)	MY54130085	20MHz~8.4GHz	Nov. 01, 2019	Jan. 27, 2020~ Feb. 09, 2020	Oct. 31, 2020	Radiation (03CH15-HY)
Signal Analyzer	R&S	FSV3044	101009	10Hz~44GHz	Nov. 11, 2019	Jan. 27, 2020~ Feb. 09, 2020	Nov. 10, 2020	Radiation (03CH15-HY)
Controller	ChainTek	3000-1	N/A	Control Turn table & Ant Mast	N/A	Jan. 27, 2020~ Feb. 09, 2020	N/A	Radiation (03CH15-HY)
Antenna Mast	ChainTek	MBS-520-1	N/A	1m~4m	N/A	Jan. 27, 2020~ Feb. 09, 2020	N/A	Radiation (03CH15-HY)
Turn Table	ChainTek	T-200-S-1	N/A	0~360 Degree	N/A	Jan. 27, 2020~ Feb. 09, 2020	N/A	Radiation (03CH15-HY)
Software	Audix	E3 6.2009-8-24(k5)	RK-000451	N/A	N/A	Jan. 27, 2020~ Feb. 09, 2020	N/A	Radiation (03CH15-HY)
RF Cable	HUBER + SUHNER	SUCOFLEX 104	MY36980/4	30M-18G	Apr. 15, 2019	Jan. 27, 2020~ Feb. 09, 2020	Apr. 14, 2020	Radiation (03CH15-HY)
RF Cable	HUBER + SUHNER	SUCOFLEX 104	MY9838/4PE	30M-18G	Apr. 15, 2019	Jan. 27, 2020~ Feb. 09, 2020	Apr. 14, 2020	Radiation (03CH15-HY)
RF Cable	HUBER + SUHNER	SUCOFLEX 104	MY802430/4	30M~18G	May. 13, 2019	Jan. 27, 2020~ Feb. 09, 2020	May. 12, 2020	Radiation (03CH15-HY)
RF Cable	HUBER + SUHNER	SUCOFLEX 102	505134/2	30MHz-40GHz	Feb. 26, 2019	Jan. 27, 2020~ Feb. 09, 2020	Feb. 25, 2020	Radiation (03CH15-HY)
RF Cable	HUBER + SUHNER	SUCOFLEX 102	800740/2	30MHz-40GHz	Feb. 26, 2019	Jan. 27, 2020~ Feb. 09, 2020	Feb. 25, 2020	Radiation (03CH15-HY)
Filter	Wainwright	WHKX12-2700-3000-18000-60ST	SN2	3GHz High Pass Filter	Jul. 17, 2019	Jan. 27, 2020~ Feb. 09, 2020	Jul. 14, 2020	Radiation (03CH15-HY)



5 Uncertainty of Evaluation

Uncertainty of Radiated Emission Measurement (30 MHz ~ 1000 MHz)

Measuring Uncertainty for a Level of Confidence of 95% ($U = 2Uc(y)$)	5.0
---	-----

Uncertainty of Radiated Emission Measurement (1000 MHz ~ 18000 MHz)

Measuring Uncertainty for a Level of Confidence of 95% ($U = 2Uc(y)$)	5.4
---	-----

Uncertainty of Radiated Emission Measurement (18000 MHz ~ 40000 MHz)

Measuring Uncertainty for a Level of Confidence of 95% ($U = 2Uc(y)$)	5.0
---	-----



Appendix A. Radiated Spurious Emission

Test Engineer :	Leo Lee, Mancy Chou, and Bigshow Wang	Temperature :	21.5~23.5°C
		Relative Humidity :	49.5~55.5%

BT_Tx_Ch78+11ax(HE20)_Tx_Ch01 (Band Edge @ 3m)

WIFI Ant.	Note	Frequency (MHz)	Level (dBμV/m)	Over Limit (dB)	Limit Line (dBμV/m)	Read Level (dBμV)	Antenna Factor (dB/m)	Path Loss (dB)	Preamp Factor (dB)	Ant Pos (cm)	Table Pos (deg)	Peak Avg. (P/A)	Pol. (H/V)	
BT_Tx_Ch78 + 11ax(HE20)_Tx_Ch01	*	2480	108.62	-	-	95.93	27.54	16.25	31.1	238	11	P	H	
	*	2480	83.83	-	-	-	-	-	-	-	-	A	H	
		2483.72	55.71	-18.29	74	43.03	27.53	16.25	31.1	238	11	P	H	
		2483.72	30.92	-23.08	54	-	-	-	-	-	-	A	H	
													H	
	*	2480	97.29	-	-	84.6	27.54	16.25	31.1	327	325	P	V	
	*	2480	72.5	-	-	-	-	-	-	-	-	-	A	V
		2486.4	53.83	-20.17	74	41.14	27.53	16.26	31.1	327	325	P	V	
		2486.4	29.04	-24.96	54	-	-	-	-	-	-	-	A	V
														V
BT_Tx_Ch78 + 11ax(HE20)_Tx_Ch01		2331.525	55.45	-18.55	74	42.5	28.04	16.08	31.17	182	82	P	H	
		2322.39	44.57	-9.43	54	31.62	28.06	16.07	31.18	182	82	A	H	
	*	2412	98.01	-	-	85.28	27.68	16.18	31.13	182	82	P	H	
	*	2412	87.74	-	-	75.01	27.68	16.18	31.13	182	82	A	H	
													P	H
													A	H
		2348.955	54.57	-19.43	74	41.64	28	16.1	31.17	182	340	P	V	
		2338.14	44.56	-9.44	54	31.62	28.02	16.09	31.17	182	340	A	V	
	*	2412	94.19	-	-	81.46	27.68	16.18	31.13	182	340	P	V	
	*	2412	84.75	-	-	72.02	27.68	16.18	31.13	182	340	A	V	
												P	V	
												A	V	
Remark	1. No other spurious found. 2. All results are PASS against Peak and Average limit line.													



BLE_Tx_Ch00+11ax(20)_Tx_Ch01 (Band Edge @ 3m)

WIFI Ant.	Note	Frequency (MHz)	Level (dBμV/m)	Over Limit (dB)	Limit Line (dBμV/m)	Read Level (dBμV)	Antenna Factor (dB/m)	Path Loss (dB)	Preamp Factor (dB)	Ant Pos (cm)	Table Pos (deg)	Peak Avg. (P/A)	Pol. (H/V)	
BLE_Tx_Ch00 + 11ax(20)_Tx_Ch01	Simultaneously	2390	57.5	-16.5	74	44.73	27.76	16.16	31.15	378	325	P	H	
		2390	45.96	-8.04	54	33.19	27.76	16.16	31.15	378	325	A	H	
	*	2402	99.75	-	-	87.02	27.7	16.17	31.14	378	325	P	H	
	*	2402	89.44	-	-	76.71	27.7	16.17	31.14	378	325	A	H	
													H	
													H	
			2389.38	61.46	-12.54	74	48.69	27.76	16.16	31.15	149	349	P	V
			2390	50.23	-3.77	54	37.46	27.76	16.16	31.15	149	349	A	V
	*		2402	105.25	-	-	92.52	27.7	16.17	31.14	149	349	P	V
	*		2402	96.14	-	-	83.41	27.7	16.17	31.14	149	349	A	V
BLE_Tx_Ch00 + 11ax(20)_Tx_Ch01		2389.68	55.9	-18.1	74	43.13	27.76	16.16	31.15	100	53	P	H	
		2390	45.32	-8.68	54	32.55	27.76	16.16	31.15	100	53	A	H	
	*	2412	99.76	-	-	87.03	27.68	16.18	31.13	100	53	P	H	
	*	2412	89.85	-	-	77.12	27.68	16.18	31.13	100	53	A	H	
													H	
													H	
			2389.84	62.94	-11.06	74	50.17	27.76	16.16	31.15	146	348	P	V
			2390	50.7	-3.3	54	37.93	27.76	16.16	31.15	146	348	A	V
	*		2412	106.87	-	-	94.14	27.68	16.18	31.13	146	348	P	V
	*		2412	97.12	-	-	84.39	27.68	16.18	31.13	146	348	A	V

Remark
 1. No other spurious found.
 2. All results are PASS against Peak and Average limit line.



BT_Tx_Ch00+11ax(HE20)_Tx_Ch36 (Band Edge @ 3m)

WIFI Ant.	Note	Frequency	Level	Over Limit	Limit Line	Read Level	Antenna Factor	Path Loss	Preamp Factor	Ant Pos	Table Pos	Peak Avg.	Pol.	
Simultaneously		(MHz)	(dBμV/m)	(dB)	(dBμV/m)	(dBμV)	(dB/m)	(dB)	(dB)	(cm)	(deg)	(P/A)	(H/V)	
BT_Tx_Ch00 + 11ax(HE20)_Tx _Ch36	*	2480	107.96	-	-	105.19	27.54	6.33	31.1	208	351	P	H	
	*	2480	83.17	-	-	-	-	-	-	-	-	A	H	
		2483.64	54.68	-19.32	74	51.92	27.53	6.33	31.1	208	351	P	H	
		2483.64	29.89	-24.11	54	-	-	-	-	-	-	A	H	
													H	
													H	
	*	2480	96.07	-	-	93.3	27.54	6.33	31.1	400	353	P	V	
	*	2480	71.28	-	-	-	-	-	-	-	-	-	A	V
		2484.92	44.28	-29.72	74	41.52	27.53	6.33	31.1	400	353	P	V	
		2484.92	19.49	-34.51	54	-	-	-	-	-	-	A	V	
BT_Tx_Ch00 + 11ax(HE20)_Tx _Ch36		5149.5	50.43	-23.57	74	39.51	32.1	9.25	30.43	350	311	P	H	
		5150	40.73	-13.27	54	29.8	32.1	9.26	30.43	350	311	A	H	
	*	5180	105.37	-	-	94.59	31.92	9.29	30.43	350	311	P	H	
	*	5180	94.4	-	-	83.62	31.92	9.29	30.43	350	311	A	H	
													H	
													H	
		5148.72	54.41	-19.59	74	43.49	32.1	9.25	30.43	169	342	P	V	
		5150	42.82	-11.18	54	31.89	32.1	9.26	30.43	169	342	A	V	
	*	5180	107.65	-	-	96.87	31.92	9.29	30.43	169	342	P	V	
	*	5180	97	-	-	86.22	31.92	9.29	30.43	169	342	A	V	
												V		
												V		
Remark	1. No other spurious found. 2. All results are PASS against Peak and Average limit line.													



BLE_Tx_Ch00+11ax(HE20)_Tx_Ch36 (Band Edge @ 3m)

WIFI Ant. Simultaneously	Note	Frequency (MHz)	Level (dBμV/m)	Over Limit (dB)	Limit Line (dBμV/m)	Read Level (dBμV)	Antenna Factor (dB/m)	Path Loss (dB)	Preamp Factor (dB)	Ant Pos (cm)	Table Pos (deg)	Peak Avg. (P/A)	Pol. (H/V)	
BLE_Tx_Ch00 + 11ax(HE20)_Tx_Ch36		2338.875	54.36	-19.64	74	41.42	28.02	16.09	31.17	221	296	P	H	
		2312.31	43.77	-10.23	54	30.81	28.08	16.06	31.18	221	296	A	H	
	*	2402	92.51	-	-	79.78	27.7	16.17	31.14	221	296	P	H	
	*	2402	91.9	-	-	79.17	27.7	16.17	31.14	221	296	A	H	
													H	
														H
			2321.235	54.71	-19.29	74	41.76	28.06	16.07	31.18	159	351	P	V
			2326.8	43.77	-10.23	54	30.83	28.05	16.07	31.18	159	351	A	V
	*		2402	98.33	-	-	85.6	27.7	16.17	31.14	159	351	P	V
	*		2402	97.7	-	-	84.97	27.7	16.17	31.14	159	351	A	V
														V
														V
BLE_Tx_Ch00 + 11ax(HE20)_Tx_Ch36		5147.16	52.98	-21.02	74	41.46	32.09	9.86	30.43	219	49	P	H	
		5149.76	43.66	-10.34	54	32.13	32.1	9.86	30.43	219	49	A	H	
	*	5180	107.29	-	-	95.89	31.92	9.91	30.43	219	49	P	H	
	*	5180	96.26	-	-	84.86	31.92	9.91	30.43	219	49	A	H	
													H	
														H
			5150	51.28	-22.72	74	39.74	32.1	9.87	30.43	256	34	P	V
			5150	42.34	-11.66	54	30.8	32.1	9.87	30.43	256	34	A	V
	*		5180	105.18	-	-	93.78	31.92	9.91	30.43	256	34	P	V
	*		5180	94.34	-	-	82.94	31.92	9.91	30.43	256	34	A	V
														V
														V
Remark	1. No other spurious found. 2. All results are PASS against Peak and Average limit line.													



11ax(n20)_Tx_Ch01+11ax(20)_Tx_Ch36 (Band Edge @ 3m)

WIFI Ant. Simultaneously	Note	Frequency (MHz)	Level (dBμV/m)	Over Limit (dB)	Limit Line (dBμV/m)	Read Level (dBμV)	Antenna Factor (dB/m)	Path Loss (dB)	Preamp Factor (dB)	Ant Pos (cm)	Table Pos (deg)	Peak Avg. (P/A)	Pol. (H/V)	
11ax(n20)_Tx_Ch01 + 11ax(20)_Tx_Ch36		2389.695	61.76	-12.24	74	48.99	27.76	16.16	31.15	229	27	P	H	
		2390	49.94	-4.06	54	37.17	27.76	16.16	31.15	229	27	A	H	
	*	2412	106.91	-	-	94.18	27.68	16.18	31.13	229	27	P	H	
	*	2412	98.05	-	-	85.32	27.68	16.18	31.13	229	27	A	H	
													H	
														H
			2390	56.81	-17.19	74	44.04	27.76	16.16	31.15	229	355	P	V
			2390	44.99	-9.01	54	32.22	27.76	16.16	31.15	229	355	A	V
	*		2412	98.91	-	-	86.18	27.68	16.18	31.13	229	355	P	V
	*		2412	89.71	-	-	76.98	27.68	16.18	31.13	229	355	A	V
														V
														V
11ax(n20)_Tx_Ch01 + 11ax(20)_Tx_Ch36		5149.5	55.03	-18.97	74	43.5	32.1	9.86	30.43	199	30	P	H	
		5150	43.77	-10.23	54	32.23	32.1	9.87	30.43	199	30	A	H	
	*	5180	107.41	-	-	96.01	31.92	9.91	30.43	199	30	P	H	
	*	5180	96.86	-	-	85.46	31.92	9.91	30.43	199	30	A	H	
													H	
														H
			5150	55.15	-18.85	74	43.61	32.1	9.87	30.43	208	348	P	V
			5150	43.23	-10.77	54	31.69	32.1	9.87	30.43	208	348	A	V
	*		5180	107.21	-	-	95.81	31.92	9.91	30.43	208	348	P	V
	*		5180	96.25	-	-	84.85	31.92	9.91	30.43	208	348	A	V
														V
														V
Remark	1. No other spurious found. 2. All results are PASS against Peak and Average limit line.													



BT_Tx_Ch78+11ax(HE20)_Tx_Ch01+11ax(HE20)_Tx_Ch36 (Band Edge @ 3m)

WIFI Ant. Simultaneously	Note	Frequency (MHz)	Level (dBμV/m)	Over Limit (dB)	Limit Line (dBμV/m)	Read Level (dBμV)	Antenna Factor (dB/m)	Path Loss (dB)	Preamp Factor (dB)	Ant Pos (cm)	Table Pos (deg)	Peak Avg. (P/A)	Pol. (H/V)	
BT_Tx_Ch78 + 11ax(HE20)_Tx_Ch01 + 11ax(HE20)_Tx_Ch36	*	2480	111.72	-	-	99.03	27.54	16.25	31.1	255	296	P	H	
	*	2480	86.93	-	-	-	-	-	-	-	-	A	H	
		2483.84	57.27	-16.73	74	44.59	27.53	16.25	31.1	255	296	P	H	
		2483.84	32.48	-21.52	54	-	-	-	-	-	-	A	H	
													H	
													H	
	*	2480	117.52	-	-	104.83	27.54	16.25	31.1	100	350	P	V	
	*	2480	92.73	-	-	-	-	-	-	-	-	-	A	V
		2483.96	61.77	-12.23	74	49.09	27.53	16.25	31.1	100	350	P	V	
		2483.96	36.98	-17.02	54	-	-	-	-	-	-	-	A	V
													V	
													V	
BT_Tx_Ch78 + 11ax(HE20)_Tx_Ch01 + 11ax(HE20)_Tx_Ch36		2389.485	60.31	-13.69	74	47.54	27.76	16.16	31.15	168	311	P	H	
		2389.905	47.06	-6.94	54	34.29	27.76	16.16	31.15	168	311	A	H	
	*	2412	99.89	-	-	87.16	27.68	16.18	31.13	168	311	P	H	
	*	2412	90.82	-	-	78.09	27.68	16.18	31.13	168	311	A	H	
													H	
													H	
		2389.485	56.25	-17.75	74	43.48	27.76	16.16	31.15	141	164	P	V	
		2390	45.61	-8.39	54	32.84	27.76	16.16	31.15	141	164	A	V	
	*	2412	96.74	-	-	84.01	27.68	16.18	31.13	141	164	P	V	
	*	2412	87.31	-	-	74.58	27.68	16.18	31.13	141	164	A	V	
													V	
													V	



BT_Tx_Ch78 + 11ax(HE20)_Tx_ Ch01 + 11ax(HE20)_Tx_ Ch36		5150	52.41	-21.59	74	41.48	32.1	9.26	30.43	359	6	P	H
		5150	42.35	-11.65	54	31.42	32.1	9.26	30.43	359	6	A	H
	*	5180	106.43	-	-	95.65	31.92	9.29	30.43	359	6	P	H
	*	5180	95.75	-	-	84.97	31.92	9.29	30.43	359	6	A	H
													H
													H
		5149.24	52.06	-21.94	74	41.14	32.1	9.25	30.43	100	1	P	V
		5150	42.78	-11.22	54	31.85	32.1	9.26	30.43	100	1	A	V
	*	5180	103.86	-	-	93.08	31.92	9.29	30.43	100	1	P	V
	*	5180	93.2	-	-	82.42	31.92	9.29	30.43	100	1	A	V
													V
													V
Remark	1. No other spurious found. 2. All results are PASS against Peak and Average limit line.												



BLE_Tx_Ch00+11ax(HE20)_Tx_Ch01+11ax(HE20)_Tx_Ch36 (Band Edge @ 3m)

WIFI Ant. Simultaneously	Note	Frequency (MHz)	Level (dBμV/m)	Over Limit (dB)	Limit Line (dBμV/m)	Read Level (dBμV)	Antenna Factor (dB/m)	Path Loss (dB)	Preamp Factor (dB)	Ant Pos (cm)	Table Pos (deg)	Peak Avg. (P/A)	Pol. (H/V)	
BLE_Tx_Ch00 + 11ax(HE20)_Tx_Ch01 + 11ax(HE20)_Tx_Ch36		2317.84	54.65	-19.35	74	41.71	28.06	16.06	31.18	171	351	P	H	
		2389.84	43.78	-10.22	54	31.01	27.76	16.16	31.15	171	351	A	H	
	*	2402	101.01	-	-	88.29	27.69	16.17	31.14	171	351	P	H	
	*	2402	99.8	-	-	87.07	27.7	16.17	31.14	171	351	A	H	
													H	
														H
			2325.04	54.62	-19.38	74	41.68	28.05	16.07	31.18	288	313	P	V
			2344.72	43.76	-10.24	54	30.82	28.01	16.1	31.17	288	313	A	V
	*		2402	90.95	-	-	78.22	27.7	16.17	31.14	288	313	P	V
	*		2402	88.99	-	-	76.26	27.7	16.17	31.14	288	313	A	V
													V	
													V	
BLE_Tx_Ch00 + 11ax(HE20)_Tx_Ch01 + 11ax(HE20)_Tx_Ch36		2373.945	55	-19	74	42.15	27.86	16.14	31.15	284	296	P	H	
		2390	44.25	-9.75	54	31.48	27.76	16.16	31.15	284	296	A	H	
	*	2412	99.28	-	-	86.55	27.68	16.18	31.13	284	296	P	H	
	*	2412	91.04	-	-	78.31	27.68	16.18	31.13	284	296	A	H	
														H
														H
			2370.9	56.48	-17.52	74	43.63	27.87	16.13	31.15	181	179	P	V
			2390	43.8	-10.2	54	31.03	27.76	16.16	31.15	181	179	A	V
	*		2412	94.37	-	-	81.64	27.68	16.18	31.13	181	179	P	V
	*		2412	86.3	-	-	73.57	27.68	16.18	31.13	181	179	A	V
													V	
													V	



BLE_Tx_Ch00 + 11ax(HE20)_Tx _Ch01 + 11ax(HE20)_Tx _Ch36		5149.76	54.41	-19.59	74	42.88	32.1	9.86	30.43	228	304	P	H
		5149.76	44.51	-9.49	54	32.98	32.1	9.86	30.43	228	304	A	H
	*	5180	106.95	-	-	95.55	31.92	9.91	30.43	228	304	P	H
	*	5180	96.29	-	-	84.89	31.92	9.91	30.43	228	304	A	H
													H
													H
		5150	51.36	-22.64	74	39.82	32.1	9.87	30.43	400	28	P	V
		5150	42.19	-11.81	54	30.65	32.1	9.87	30.43	400	28	A	V
	*	5180	103.79	-	-	92.39	31.92	9.91	30.43	400	28	P	V
	*	5180	93.04	-	-	81.64	31.92	9.91	30.43	400	28	A	V
													V
													V
	Remark	1. No other spurious found. 2. All results are PASS against Peak and Average limit line.											



LTE Band 7 BW 20M+11ax(HE20)_Tx_Ch01 (Band Edge @ 3m)

WIFI Ant. Simultaneously	Note	Frequency (MHz)	Level (dBμV/m)	Over Limit (dB)	Limit Line (dBμV/m)	Read Level (dBμV)	Antenna Factor (dB/m)	Path Loss (dB)	Preamp Factor (dB)	Ant Pos (cm)	Table Pos (deg)	Peak Avg. (P/A)	Pol. (H/V)	
LTE Band 7 BW 20M + 11ax(HE20)_Tx_Ch01		2389.695	62.77	-11.23	74	50	27.76	16.16	31.15	151	23	P	H	
		2390	48.91	-5.09	54	36.14	27.76	16.16	31.15	151	23	A	H	
	*	2412	108.08	-	-	95.35	27.68	16.18	31.13	151	23	P	H	
	*	2412	97.96	-	-	85.23	27.68	16.18	31.13	151	23	A	H	
													H	
														H
			2357.46	54.97	-19.03	74	42.06	27.96	16.11	31.16	269	35	P	V
			2326.065	43.52	-10.48	54	30.58	28.05	16.07	31.18	269	35	A	V
	*		2412	98.72	-	-	85.99	27.68	16.18	31.13	269	35	P	V
	*		2412	84.23	-	-	71.5	27.68	16.18	31.13	269	35	A	V
														V
														V
	Remark	1. No other spurious found. 2. All results are PASS against Peak and Average limit line.												



BT_Tx_Ch78+11ax(HE20)_Tx_Ch01 (Harmonic @ 3m)

WIFI Ant. Simultaneously	Note	Frequency (MHz)	Level (dBμV/m)	Over Limit (dB)	Limit Line (dBμV/m)	Read Level (dBμV)	Antenna Factor (dB/m)	Path Loss (dB)	Preamp Factor (dB)	Ant Pos (cm)	Table Pos (deg)	Peak Avg. (P/A)	Pol. (H/V)	
BT_Tx_Ch78 + 11ax(HE20)_Tx_Ch01		4824	35.68	-38.32	74	53.96	31.25	9.63	59.16	100	0	P	H	
		4960	36.3	-37.7	74	54.3	31.54	9.65	59.19	100	0	P	H	
		7440	42.38	-31.62	74	53.18	36.56	11.76	59.12	100	0	P	H	
													H	
													H	
													H	
													H	
													H	
			4824	36.7	-37.3	74	54.98	31.25	9.63	59.16	100	0	P	V
			4960	36.49	-37.51	74	54.49	31.54	9.65	59.19	100	0	P	V
			7440	41.63	-32.37	74	52.43	36.56	11.76	59.12	100	0	P	V
													V	
													V	
													V	
												V		
												V		
Remark	1. No other spurious found. 2. All results are PASS against Peak and Average limit line.													



BLE_Tx_Ch00+11ax(20)_Tx_Ch01 (Harmonic @ 3m)

WIFI Ant. Simultaneously	Note	Frequency (MHz)	Level (dBμV/m)	Over Limit (dB)	Limit Line (dBμV/m)	Read Level (dBμV)	Antenna Factor (dB/m)	Path Loss (dB)	Preamp Factor (dB)	Ant Pos (cm)	Table Pos (deg)	Peak Avg. (P/A)	Pol. (H/V)	
BLE_Tx_Ch00 + 11ax(20)_Tx_Ch01		4804	35.47	-38.53	74	53.8	31.21	9.62	59.16	100	0	P	H	
		4824	35.36	-38.64	74	53.64	31.25	9.63	59.16	100	0	P	H	
													H	
													H	
													H	
													H	
													H	
													H	
			4804	34.99	-39.01	74	53.32	31.21	9.62	59.16	100	0	P	V
			4824	35.16	-38.84	74	53.44	31.25	9.63	59.16	100	0	P	V
														V
														V
														V
														V
														V
	Remark	1. No other spurious found. 2. All results are PASS against Peak and Average limit line.												



BT_Tx_Ch00+11ax(HE20)_Tx_Ch36 (Harmonic @ 3m)

WIFI Ant. Simultaneously	Note	Frequency (MHz)	Level (dBμV/m)	Over Limit (dB)	Limit Line (dBμV/m)	Read Level (dBμV)	Antenna Factor (dB/m)	Path Loss (dB)	Preamp Factor (dB)	Ant Pos (cm)	Table Pos (deg)	Peak Avg. (P/A)	Pol. (H/V)	
BT_Tx_Ch00 + 11ax(HE20)_Tx_Ch36		4824	32.25	-41.75	74	49.36	31.25	10.8	59.16	100	0	P	H	
		4960	33.88	-40.12	74	50.64	31.54	10.89	59.19	100	0	P	H	
		7440	42.02	-31.98	74	51.13	36.56	13.45	59.12	100	0	P	H	
		10360	44.25	-23.95	68.2	50.39	39.9	14.72	60.76	100	0	P	H	
		15540	44.7	-29.3	74	50.71	38	17.54	61.55	100	0	P	H	
														H
														H
														H
			4824	32.11	-41.89	74	49.22	31.25	10.8	59.16	100	0	P	V
			4960	35.07	-38.93	74	51.83	31.54	10.89	59.19	100	0	P	V
			7440	42.4	-31.6	74	51.51	36.56	13.45	59.12	100	0	P	V
			10360	45.15	-23.05	68.2	51.29	39.9	14.72	60.76	100	0	P	V
			15540	45.6	-28.4	74	51.61	38	17.54	61.55	100	0	P	V
														V
														V
														V
Remark	1. No other spurious found. 2. All results are PASS against Peak and Average limit line.													



BLE_Tx_Ch00+11ax(HE20)_Tx_Ch36 (Harmonic @ 3m)

WIFI Ant. Simultaneously	Note	Frequency (MHz)	Level (dBμV/m)	Over Limit (dB)	Limit Line (dBμV/m)	Read Level (dBμV)	Antenna Factor (dB/m)	Path Loss (dB)	Preamp Factor (dB)	Ant Pos (cm)	Table Pos (deg)	Peak Avg. (P/A)	Pol. (H/V)	
BLE_Tx_Ch00 + 11ax(HE20)_Tx_Ch36		4804	32.66	-41.34	74	49.83	31.21	10.78	59.16	100	0	P	H	
		10360	44.86	-23.34	68.2	50.95	39.9	14.77	60.76	100	0	P	H	
		15540	44.84	-29.16	74	50.95	38	17.44	61.55	100	0	P	H	
													H	
													H	
													H	
													H	
														H
														H
			4804	32.59	-41.41	74	49.76	31.21	10.78	59.16	100	0	P	V
			10360	45.13	-23.07	68.2	51.22	39.9	14.77	60.76	100	0	P	V
			15540	45.45	-28.55	74	51.56	38	17.44	61.55	100	0	P	V
														V
														V
														V
													V	
													V	
Remark	1. No other spurious found. 2. All results are PASS against Peak and Average limit line.													



11ax(n20)_Tx_Ch01+11ax(20)_Tx_Ch36 (Harmonic @ 3m)

WIFI Ant. Simultaneously	Note	Frequency (MHz)	Level (dBμV/m)	Over Limit (dB)	Limit Line (dBμV/m)	Read Level (dBμV)	Antenna Factor (dB/m)	Path Loss (dB)	Preamp Factor (dB)	Ant Pos (cm)	Table Pos (deg)	Peak Avg. (P/A)	Pol. (H/V)	
11ax(n20)_Tx_C h01 + 11ax(20)_Tx_Ch 36		4824	32.71	-41.29	74	49.82	31.25	10.8	59.16	100	0	P	H	
		10360	46.26	-21.94	68.2	52.4	39.9	14.72	60.76	100	0	P	H	
		15540	44.97	-29.03	74	50.98	38	17.54	61.55	100	0	P	H	
													H	
													H	
													H	
													H	
													H	
			4824	32.17	-41.83	74	49.28	31.25	10.8	59.16	100	0	P	V
			10360	45.86	-22.34	68.2	51.95	39.9	14.77	60.76	100	0	P	V
			15540	46.12	-27.88	74	52.23	38	17.44	61.55	100	0	P	V
													V	
													V	
													V	
													V	
												V		
Remark	1. No other spurious found. 2. All results are PASS against Peak and Average limit line.													



BT_Tx_Ch78+11ax(HE20)_Tx_Ch01+11ax(HE20)_Tx_Ch36 (Harmonic @ 3m)

WIFI Ant. Simultaneously	Note	Frequency (MHz)	Level (dBμV/m)	Over Limit (dB)	Limit Line (dBμV/m)	Read Level (dBμV)	Antenna Factor (dB/m)	Path Loss (dB)	Preamp Factor (dB)	Ant Pos (cm)	Table Pos (deg)	Peak Avg. (P/A)	Pol. (H/V)	
BT_Tx_Ch78 + 11ax(HE20)_Tx_Ch01 + 11ax(HE20)_Tx_Ch36		4824	32.23	-41.77	74	49.34	31.25	10.8	59.16	100	0	P	H	
		4960	35.4	-38.6	74	52.16	31.54	10.89	59.19	100	0	P	H	
		7440	42.07	-31.93	74	51.37	36.56	13.26	59.12	100	0	P	H	
		10360	44.61	-23.59	68.2	50.7	39.9	14.77	60.76	100	0	P	H	
		15540	45.56	-28.44	74	51.67	38	17.44	61.55	100	0	P	H	
														H
														H
														H
			4824	32.21	-41.79	74	49.32	31.25	10.8	59.16	100	0	P	V
			4960	32.94	-41.06	74	49.7	31.54	10.89	59.19	100	0	P	V
			7440	42.24	-31.76	74	51.54	36.56	13.26	59.12	100	0	P	V
			10360	45.34	-22.86	68.2	51.43	39.9	14.77	60.76	100	0	P	V
			15540	45.47	-28.53	74	51.58	38	17.44	61.55	100	0	P	V
														V
													V	
													V	
Remark	1. No other spurious found. 2. All results are PASS against Peak and Average limit line.													



BLE_Tx_Ch00+11ax(HE20)_Tx_Ch01+11ax(HE20)_Tx_Ch36 (Harmonic @ 3m)

WIFI Ant. Simultaneously	Note	Frequency (MHz)	Level (dBµV/m)	Over Limit (dB)	Limit Line (dBµV/m)	Read Level (dBµV)	Antenna Factor (dB/m)	Path Loss (dB)	Preamp Factor (dB)	Ant Pos (cm)	Table Pos (deg)	Peak Avg. (P/A)	Pol. (H/V)	
BLE_Tx_Ch00 + 11ax(HE20)_Tx_Ch01 + 11ax(HE20)_Tx_Ch36		4804	34.5	-39.5	74	51.67	31.21	10.78	59.16	100	0	P	H	
		4824	32.94	-41.06	74	50.05	31.25	10.8	59.16	100	0	P	H	
		10360	44.95	-23.25	68.2	51.09	39.9	14.72	60.76	100	0	P	H	
		15540	45.16	-28.84	74	51.17	38	17.54	61.55	100	0	P	H	
													H	
													H	
													H	
													H	
			4804	32.55	-41.45	74	49.72	31.21	10.78	59.16	100	0	P	V
			4824	32.09	-41.91	74	49.2	31.25	10.8	59.16	100	0	P	V
			10360	45.42	-22.78	68.2	51.56	39.9	14.72	60.76	100	0	P	V
			15540	45.4	-28.6	74	51.41	38	17.54	61.55	100	0	P	V
													V	
													V	
												V		
												V		
Remark	1. No other spurious found. 2. All results are PASS against Peak and Average limit line.													



LTE Band 7 BW 20M+11ax(HE20)_Tx_Ch01 (Harmonic @ 3m)

WIFI Ant. Simultaneously	Note	Frequency (MHz)	Level (dBμV/m)	Over Limit (dB)	Limit Line (dBμV/m)	Read Level (dBμV)	Antenna Factor (dB/m)	Path Loss (dB)	Preamp Factor (dB)	Ant Pos (cm)	Table Pos (deg)	Peak Avg. (P/A)	Pol. (H/V)	
LTE Band 7 BW 20M + 11ax(HE20)_Tx_Ch01		4824	35.73	-38.27	74	54.01	31.25	9.63	59.16	100	0	P	H	
													H	
													H	
													H	
													H	
													H	
													H	
													H	
			4824	35.9	-38.1	74	54.18	31.25	9.63	59.16	100	0	P	V
														V
														V
														V
														V
														V
Remark	1. No other spurious found. 2. All results are PASS against Peak and Average limit line.													



Note symbol

*	Fundamental Frequency which can be ignored. However, the level of any unwanted emissions shall not exceed the level of the fundamental frequency.
!	Test result is over limit line.
P/A	Peak or Average
H/V	Horizontal or Vertical



A calculation example for radiated spurious emission is shown as below:

WIFI	Note	Frequency	Level	Over	Limit	Read	Antenna	Path	Preamp	Ant	Table	Peak	Pol.
Ant.				Limit	Line	Level	Factor	Loss	Factor	Pos	Pos	Avg.	
1		(MHz)	(dBμV/m)	(dB)	(dBμV/m)	(dBμV)	(dB/m)	(dB)	(dB)	(cm)	(deg)	(P/A)	(H/V)
802.11b		2390	55.45	-18.55	74	54.51	32.22	4.58	35.86	103	308	P	H
CH 01													
2412MHz		2390	43.54	-10.46	54	42.6	32.22	4.58	35.86	103	308	A	H

1. Path Loss(dB) = Cable loss(dB) + Filter loss(dB) + Attenuator loss(dB)
2. Level(dBμV/m) =
Antenna Factor(dB/m) + Path Loss(dB) + Read Level(dBμV) - Preamp Factor(dB)
3. Over Limit(dB) = Level(dBμV/m) – Limit Line(dBμV/m)

For Peak Limit @ 2390MHz:

1. Level(dBμV/m)
= Antenna Factor(dB/m) + Path Loss(dB) + Read Level(dBμV) - Preamp Factor(dB)
= 32.22(dB/m) + 4.58(dB) + 54.51(dBμV) – 35.86 (dB)
= 55.45 (dBμV/m)
2. Over Limit(dB)
= Level(dBμV/m) – Limit Line(dBμV/m)
= 55.45(dBμV/m) – 74(dBμV/m)
= -18.55(dB)

For Average Limit @ 2390MHz:

1. Level(dBμV/m)
= Antenna Factor(dB/m) + Path Loss(dB) + Read Level(dBμV) - Preamp Factor(dB)
= 32.22(dB/m) + 4.58(dB) + 42.6(dBμV) – 35.86 (dB)
= 43.54 (dBμV/m)
2. Over Limit(dB)
= Level(dBμV/m) – Limit Line(dBμV/m)
= 43.54(dBμV/m) – 54(dBμV/m)
= -10.46(dB)

Both peak and average measured complies with the limit line, so test result is “PASS”.



Appendix B. Radiated Spurious Emission

Test Engineer :	Leo Lee, Mancy Chou, and Bigshow Wang	Temperature :	21.5~23.5°C
		Relative Humidity :	49.5~55.5%

Note symbol

-L	Low channel location
-R	High channel location



BT_Tx_Ch78+11ax(HE20)_Tx_Ch01 (Band Edge @ 3m)

ANT	BT_Tx_Ch78+11ax(HE20)_Tx_Ch01 - R	
Simultaneously	Horizontal	Fundamental
<p style="text-align: center;">Peak</p>	<p style="text-align: right;">Date: 2020-02-08</p> <p style="text-align: center;">PEAK_BE_74</p> <p>Site : 03CX15-HY Condition : PEAK_BE_74 3m 91200_15_1620 HORIZONTAL Detector : Peak Project : 900635 BT_Channel : 0465 11ax(HE20)_Tx_Ch01 : 18.5</p>	<p style="text-align: right;">Date: 2020-02-08</p> <p style="text-align: center;">PEAK_74</p> <p>Site : 03CX15-HY Condition : PEAK_74 3m 91200_15_1620 HORIZONTAL Detector : Peak Project : 900635 BT_Channel : 0465 11ax(HE20)_Tx_Ch01 : 18.5</p>

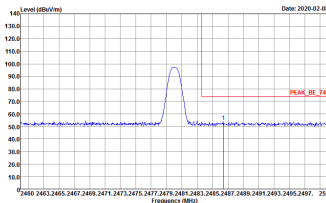
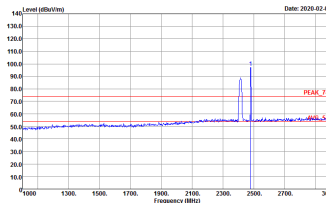

ANT	BT_Tx_Ch78+11ax(HE20)_Tx_Ch01 - R	
Simultaneously	Vertical	Fundamental
<p style="text-align: center;">Peak</p>	 <p style="text-align: right;">Date: 2020-02-08</p> <p style="text-align: center;">PEAK_RE_74</p> <pre> Site : 03CH15-HY Condition : PEAK_RE_74 Site 91200_15_1620 VERTICAL Detector : Peak Project : 950635 BT_Ch78 : DHS 11ax(HE20)_Tx_Ch01 : 18.5 </pre>	 <p style="text-align: right;">Date: 2020-02-08</p> <p style="text-align: center;">PEAK_74</p> <pre> Site : 03CH15-HY Condition : PEAK_74 Site 91200_15_1620 VERTICAL Detector : Peak Project : 950635 BT_Ch78 : DHS 11ax(HE20)_Tx_Ch01 : 18.5 </pre>

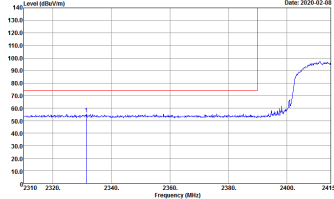
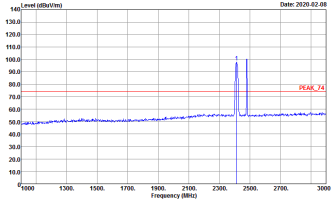
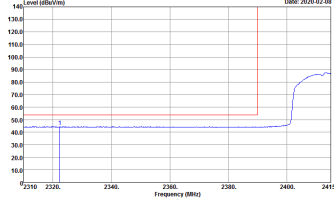
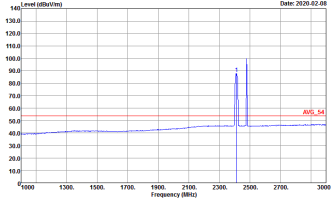

BT_Tx_Ch78+11ax(HE20)_Tx_Ch01 (Band Edge @ 3m)

ANT	BT_Tx_Ch78+11ax(HE20)_Tx_Ch01 - L	
Simultaneously	Horizontal	Fundamental
<p style="text-align: center;">Peak</p>	 <p>Site : 03CH15-HY Condition : PEAK_BE_74 3m 91200_15_1620 HORIZONTAL Detector : Peak Project : 900635 BT_CH78 : DH9 11ax(HE20)_Tx_Ch01 : 18.5</p>	 <p>Site : 03CH15-HY Condition : PEAK_74 3m 91200_15_1620 HORIZONTAL Detector : Peak Project : 900635 BT_CH78 : DH9 11ax(HE20)_Tx_Ch01 : 18.5</p>
<p style="text-align: center;">Avg.</p>	 <p>Site : 03CH15-HY Condition : AVG_BE_54 3m 91200_15_1620 HORIZONTAL Detector : Peak Project : 900635 BT_CH78 : DH9 11ax(HE20)_Tx_Ch01 : 18.5</p>	 <p>Site : 03CH15-HY Condition : AVG_54 3m 91200_15_1620 HORIZONTAL Detector : Peak Project : 900635 BT_CH78 : DH9 11ax(HE20)_Tx_Ch01 : 18.5</p>

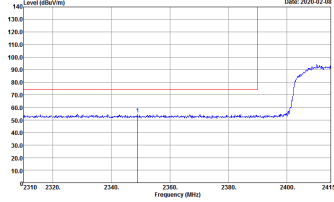
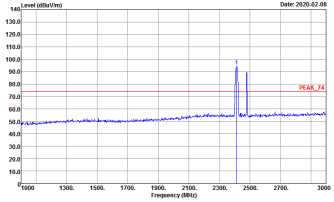
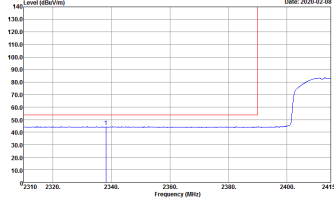
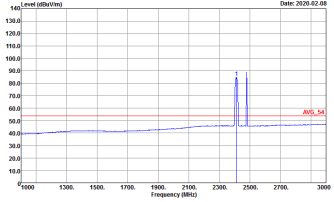

ANT	BT_Tx_Ch78+11ax(HE20)_Tx_Ch01 - L	
Simultaneously	Vertical	Fundamental
<p style="text-align: center;">Peak</p>	 <p>Site : 03CH15-HY Condition : PEAK_BE_74 3m 91200_15_1620 VERTICAL Detector : Peak Project : 900635 BT_Ch78 : DH5 Ilox(HE20)_Tx_Ch01 : 18.5</p>	 <p>Site : 03CH15-HY Condition : PEAK_74 3m 91200_15_1620 VERTICAL Detector : Peak Project : 900635 BT_Ch78 : DH5 Ilox(HE20)_Tx_Ch01 : 18.5</p>
<p style="text-align: center;">Avg.</p>	 <p>Site : 03CH15-HY Condition : AVG_BE_54 3m 91200_15_1620 VERTICAL Detector : Peak Project : 900635 BT_Ch78 : DH5 Ilox(HE20)_Tx_Ch01 : 18.5</p>	 <p>Site : 03CH15-HY Condition : AVG_54 3m 91200_15_1620 VERTICAL Detector : Peak Project : 900635 BT_Ch78 : DH5 Ilox(HE20)_Tx_Ch01 : 18.5</p>

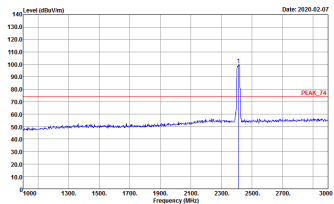
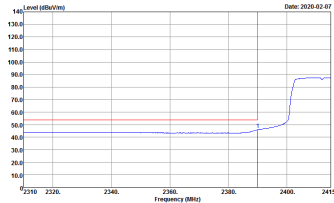

BLE_Tx_Ch00+11ax(20)_Tx_Ch01 (Band Edge @ 3m)

ANT	BLE_Tx_Ch00+11ax(20)_Tx_Ch01 - L	
Simultaneously	Horizontal	Fundamental
<p>Peak</p>	 <p>Site : 03CH15-HY Condition : PEAK_BE_74 3m 91200_15_1620 HORIZONTAL Detector : Peak Project : 900635 BLE Setting : 9 WLAN setting : 17</p>	 <p>Site : 03CH15-HY Condition : PEAK_74 3m 91200_15_1620 HORIZONTAL Detector : Peak Project : 900635 BLE Setting : 9 WLAN setting : 17</p>
<p>Avg.</p>	 <p>Site : 03CH15-HY Condition : AVG_BE_54 3m 91200_15_1620 HORIZONTAL Detector : Peak Project : 900635 BLE Setting : 9 WLAN setting : 17</p>	 <p>Site : 03CH15-HY Condition : AVG_54 3m 91200_15_1620 HORIZONTAL Detector : Peak Project : 900635 BLE Setting : 9 WLAN setting : 17</p>



ANT	BLE_Tx_Ch00+11ax(20)_Tx_Ch01 - L	
Simultaneously	Vertical	Fundamental
<p style="text-align: center;">Peak</p>	 <p>Site : 03CH15-4Y Condition : PEAK_BE_74 3m 91200_15_1620 VERTICAL Detector : Peak Project : 900635 BLE Setting : 9 WLAN setting : 17</p>	 <p>Site : 03CH15-4Y Condition : PEAK_74 3m 91200_15_1620 VERTICAL Detector : Peak Project : 900635 BLE Setting : 9 WLAN setting : 17</p>
<p style="text-align: center;">Avg.</p>	 <p>Site : 03CH15-4Y Condition : AVG_BE_54 3m 91200_15_1620 VERTICAL Detector : Peak Project : 900635 BLE Setting : 9 WLAN setting : 17</p>	 <p>Site : 03CH15-4Y Condition : AVG_54 3m 91200_15_1620 VERTICAL Detector : Peak Project : 900635 BLE Setting : 9 WLAN setting : 17</p>

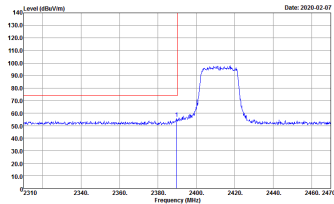
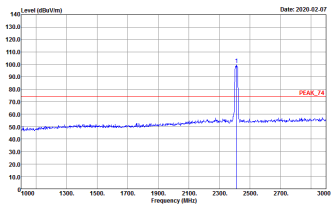
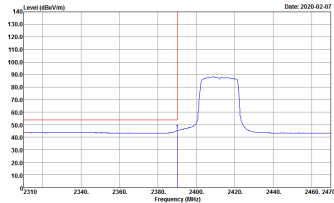
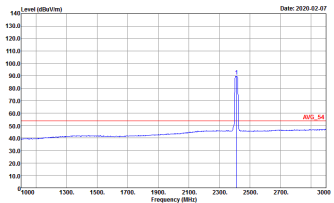

BLE_Tx_Ch00+11ax(20)_Tx_Ch01 (Band Edge @ 3m)

ANT	BLE_Tx_Ch00+11ax(20)_Tx_Ch01 - L	
Simultaneously	Horizontal	Fundamental
<p style="text-align: center;">Peak</p>	 <p>Site : 03CH5-HY Condition : PEAK_BE_74 3m 91200_15_1620 HORIZONTAL Detector : Peak Project : 9D0635 Setting : 17</p>	 <p>Site : 03CH5-HY Condition : PEAK_F4 3m 91200_15_1620 HORIZONTAL Detector : Peak Project : 9D0635 Setting : 17</p>
<p style="text-align: center;">Avg.</p>	 <p>Site : 03CH5-HY Condition : AVG_BE_54 3m 91200_15_1620 HORIZONTAL Detector : Peak Project : 9D0635 Setting : 17</p>	 <p>Site : 03CH5-HY Condition : AVG_F4 3m 91200_15_1620 HORIZONTAL Detector : Peak Project : 9D0635 Setting : 17</p>

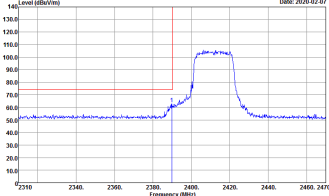
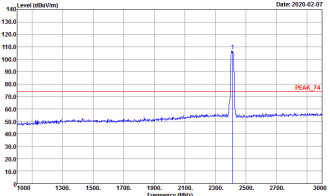
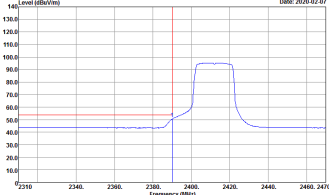

ANT	BLE_Tx_Ch00+11ax(20)_Tx_Ch01 - L	
Simultaneously	Vertical	Fundamental
<p style="text-align: center;">Peak</p>	 <p style="font-size: small;">Date: 2020-02-07</p> <p>Site : 03CH15-HY Condition : PEAK_BE_74 3m 91200_15_1620 VERTICAL : RBW:1000.0000kHz VBW:3000.0000kHz SWT:Auto Detector : Peak Project : 900635 Setting : 17</p>	 <p style="font-size: small;">Date: 2020-02-07</p> <p>Site : 03CH15-HY Condition : PEAK_74 3m 91200_15_1620 VERTICAL : RBW:1000.0000kHz VBW:3000.0000kHz SWT:Auto Detector : Peak Project : 900635 Setting : 17</p>
<p style="text-align: center;">Avg.</p>	 <p style="font-size: small;">Date: 2020-02-07</p> <p>Site : 03CH15-HY Condition : AVG_BE_54 3m 91200_15_1620 VERTICAL : RBW:1000.0000kHz VBW:10.0100kHz SWT:Auto Detector : Peak Project : 900635 Setting : 17</p>	 <p style="font-size: small;">Date: 2020-02-07</p> <p>Site : 03CH15-HY Condition : AVG_54 3m 91200_15_1620 VERTICAL : RBW:1000.0000kHz VBW:10.0100kHz SWT:Auto Detector : Peak Project : 900635 Setting : 17</p>

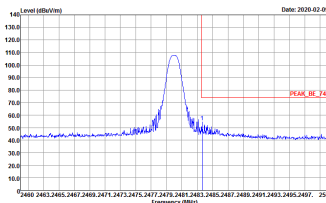
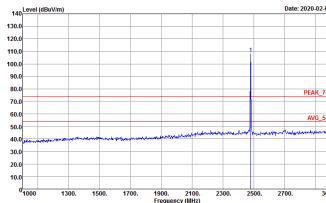

BT_Tx_Ch00+11ax(HE20)_Tx_Ch36 (Band Edge @ 3m)

ANT	BT_Tx_Ch00+11ax(HE20)_Tx_Ch36	
Simultaneously	Horizontal	Fundamental
<p style="text-align: center;">Peak</p>	 <p>Site : 03CH15-HY Condition : PEAK_BE_74 3m 91200_15_1620 HORIZONTAL RBW:3000.000kHz VBW:3000.000kHz SWT:Auto Detector : Peak Project : 9D0635</p>	 <p>Site : 03CH15-HY Condition : PEAK_74 3m 91200_15_1620 HORIZONTAL RBW:3000.000kHz VBW:3000.000kHz SWT:Auto Detector : Peak Project : 9D0635</p>

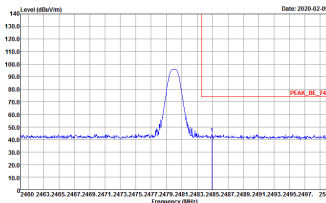
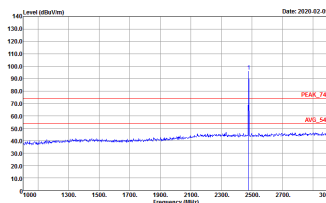

ANT	BT_Tx_Ch00+11ax(HE20)_Tx_Ch36	
Simultaneously	Vertical	Fundamental
<p style="text-align: center;">Peak</p>	 <p>Site : 03CH5-HY Condition : PEAK_RE_74 3m 91200_15_1630 VERTICAL Detector : Peak Project : 900635</p>	 <p>Site : 03CH5-HY Condition : PEAK_74 3m 91200_15_1630 VERTICAL Detector : Peak Project : 900635</p>



BT_Tx_Ch00+11ax(HE20)_Tx_Ch36 (Band Edge @ 3m)

ANT	BT_Tx_Ch00+11ax(HE20)_Tx_Ch36 - L	
Simultaneously	Horizontal	Fundamental
<p style="text-align: center;">Peak</p>	<p>Site : 03CH15-HY Condition : PEAK_BE_74 3m 91200_15_1620 HORIZONTAL Detector : Peak Project : 9D0635</p>	<p>Site : 03CH15-HY Condition : PEAK(UNIT) 3m 91200_15_1620 HORIZONTAL Detector : Peak Project : 9D0635</p>
<p style="text-align: center;">Avg.</p>	<p>Site : 03CH15-HY Condition : AVG_BE_54 3m 91200_15_1620 HORIZONTAL Detector : Peak Project : 9D0635</p>	<p style="text-align: center;">Left blank</p>

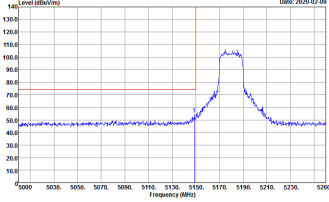
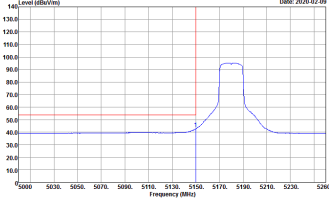

ANT	BT_Tx_Ch00+11ax(HE20)_Tx_Ch36 - L	
Simultaneously	Vertical	Fundamental
<p style="text-align: center;">Peak</p>	 <p>Site : 03CH5-HY Condition : PEAK_BE_74 3m 91200_15_1620 VERTICAL Detector : Peak Project : 900635</p>	 <p>Site : 03CH5-HY Condition : PEAK(FUN1) 3m 91200_15_1620 VERTICAL Detector : Peak Project : 900635</p>
<p style="text-align: center;">Avg.</p>	 <p>Site : 03CH5-HY Condition : AVG_BE_54 3m 91200_15_1620 VERTICAL Detector : Peak Project : 900635</p>	<p style="text-align: center;">Left blank</p>

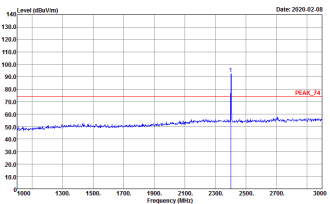

BLE_Tx_Ch00+11ax(HE20)_Tx_Ch36 (Band Edge @ 3m)

ANT	BLE_Tx_Ch00+11ax(HE20)_Tx_Ch36	
Simultaneously	Horizontal	Fundamental
<p>Peak</p>	 <p>Site : 03CH15-11Y Condition : PEAK_BE_74 3m 91200_15_1620 HORIZONTAL Detector : Peak Project : 900635 BLE Setting : 9 WLAN setting : 17.5</p>	 <p>Site : 03CH15-11Y Condition : PEAK_74 3m 91200_15_1620 HORIZONTAL Detector : Peak Project : 900635 BLE Setting : 9 WLAN setting : 17.5</p>
<p>Avg.</p>	 <p>Site : 03CH15-11Y Condition : AVG_BE_54 3m 91200_15_1620 HORIZONTAL Detector : Peak Project : 900635 BLE Setting : 9 WLAN setting : 17.5</p>	 <p>Site : 03CH15-11Y Condition : AVG_54 3m 91200_15_1620 HORIZONTAL Detector : Peak Project : 900635 BLE Setting : 9 WLAN setting : 17.5</p>

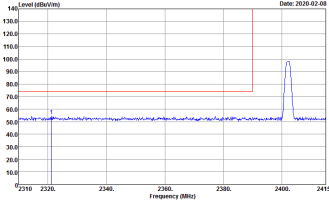
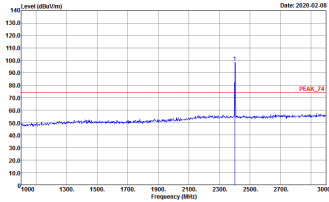
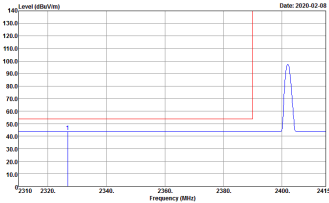
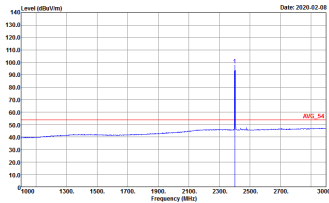

ANT	BLE_Tx_Ch00+11ax(HE20)_Tx_Ch36	
Simultaneously	Vertical	Fundamental
<p style="text-align: center;">Peak</p>	 <p>Site : 03CH15-HY Condition : PEAK_BE_74 3m 91200_15_1620 VERTICAL Detector : Peak Project : 900635 BLE Setting : 9 WLAN setting : 17.5</p>	 <p>Site : 03CH15-HY Condition : PEAK_74 3m 91200_15_1620 VERTICAL Detector : Peak Project : 900635 BLE Setting : 9 WLAN setting : 17.5</p>
<p style="text-align: center;">Avg.</p>	 <p>Site : 03CH15-HY Condition : AVG_BE_54 3m 91200_15_1620 VERTICAL Detector : Peak Project : 900635 BLE Setting : 9 WLAN setting : 17.5</p>	 <p>Site : 03CH15-HY Condition : AVG_54 3m 91200_15_1620 VERTICAL Detector : Peak Project : 900635 BLE Setting : 9 WLAN setting : 17.5</p>



BLE_Tx_Ch00+11ax(HE20)_Tx_Ch36 (Band Edge @ 3m)

ANT	BLE_Tx_Ch00+11ax(HE20)_Tx_Ch36 - L	
Simultaneously	Horizontal	Fundamental
<p style="text-align: center;">Peak</p>	 <p>Site : 03CH15-11V Condition : PEAK_BE_74 3m 91200_15_1620 HORIZONTAL Detector : Peak Project : 900635 BLE Setting : 9 WLAN setting : 17.5</p>	 <p>Site : 03CH15-11V Condition : PEAK(UNI1) 3m 91200_15_1620 HORIZONTAL Detector : Peak Project : 900635 BLE Setting : 9 WLAN setting : 17.5</p>
<p style="text-align: center;">Avg.</p>	 <p>Site : 03CH15-11V Condition : AVG_BE_74 3m 91200_15_1620 HORIZONTAL Detector : Peak Project : 900635 BLE Setting : 9 WLAN setting : 17.5</p>	<p style="text-align: center;">Left blank</p>



ANT	BLE_Tx_Ch00+11ax(HE20)_Tx_Ch36 - L	
Simultaneously	Vertical	Fundamental
<p style="text-align: center;">Peak</p>	 <p style="font-size: small;">Date: 2020-02-07</p> <p style="font-size: x-small;">Site : 03CH15-HY Condition : PEAK_BE_74 3m 91200_15_1620 VERTICAL Detector : Peak Project : 900635 BLE Setting : 9 WLAN setting : 17.5</p>	 <p style="font-size: small;">Date: 2020-02-07</p> <p style="font-size: x-small;">Site : 03CH15-HY Condition : PEAK(FUNEL) 3m 91200_15_1620 VERTICAL Detector : Peak Project : 900635 BLE Setting : 9 WLAN setting : 17.5</p>
<p style="text-align: center;">Avg.</p>	 <p style="font-size: small;">Date: 2020-02-07</p> <p style="font-size: x-small;">Site : 03CH15-HY Condition : AVG_BE_54 3m 91200_15_1620 VERTICAL Detector : Peak Project : 900635 BLE Setting : 9 WLAN setting : 17.5</p>	<p style="text-align: center;">Left blank</p>

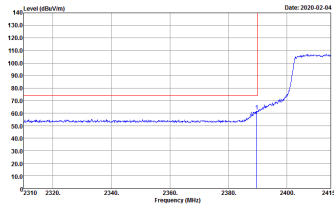
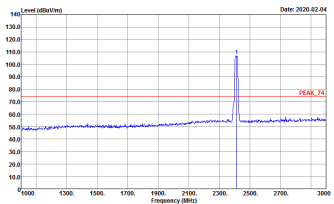
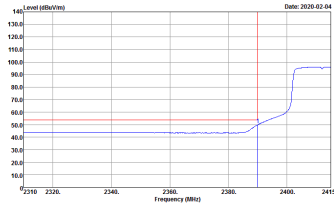
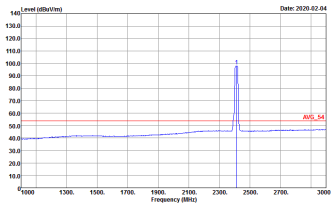

11ax(n20)_Tx_Ch01+11ax(20)_Tx_Ch36 (Band Edge @ 3m)

ANT	11ax(n20)_Tx_Ch01+11ax(20)_Tx_Ch36 - L	
Simultaneously	Horizontal	Fundamental
<p style="text-align: center;">Peak</p>	 <p>Site : 03CH5-HY Condition : PEAK_BE_74 3m 91200_15_1620 HORIZONTAL Detector : Peak Project : 900635 Setting : 17.5</p>	 <p>Site : 03CH5-HY Condition : PEAK_F4 3m 91200_15_1620 HORIZONTAL Detector : Peak Project : 900635 Setting : 17.5</p>
<p style="text-align: center;">Avg.</p>	 <p>Site : 03CH5-HY Condition : AVG_BE_54 3m 91200_15_1620 HORIZONTAL Detector : Peak Project : 900635 Setting : 17.5</p>	 <p>Site : 03CH5-HY Condition : AVG_F4 3m 91200_15_1620 HORIZONTAL Detector : Peak Project : 900635 Setting : 17.5</p>

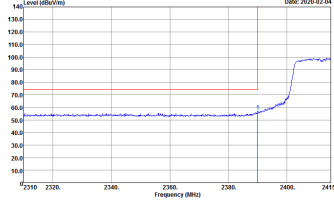
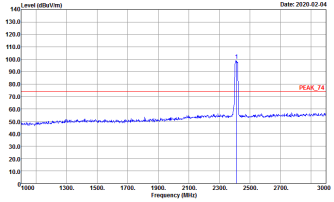
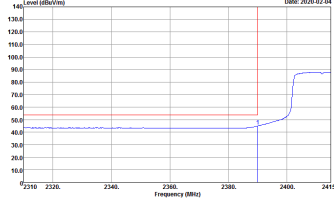
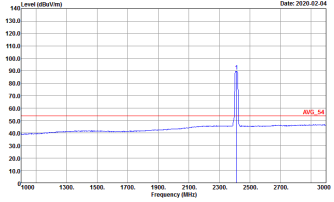

ANT	11ax(n20)_Tx_Ch01+11ax(20)_Tx_Ch36 - L	
Simultaneously	Vertical	Fundamental
<p style="text-align: center;">Peak</p>	 <p>Site : 03CH5-HY Condition : PEAK_BE_74 3m 91200_15_1620 VERTICAL Detector : Peak Project : 900635 Setting : 17.5</p>	 <p>Site : 03CH5-HY Condition : PEAK_74 3m 91200_15_1620 VERTICAL Detector : Peak Project : 900635 Setting : 17.5</p>
<p style="text-align: center;">Avg.</p>	 <p>Site : 03CH5-HY Condition : AVG_BE_54 3m 91200_15_1620 VERTICAL Detector : Peak Project : 900635 Setting : 17.5</p>	 <p>Site : 03CH5-HY Condition : AVG_54 3m 91200_15_1620 VERTICAL Detector : Peak Project : 900635 Setting : 17.5</p>

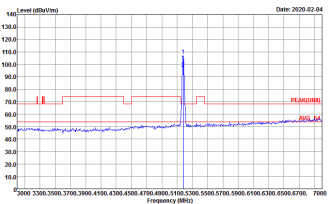
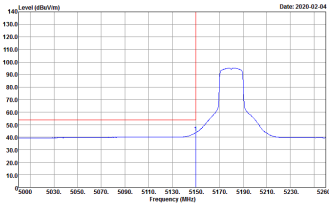

11ax(n20)_Tx_Ch01+11ax(20)_Tx_Ch36 (Band Edge @ 3m)

ANT	11ax(n20)_Tx_Ch01+11ax(20)_Tx_Ch36 - L	
Simultaneously	Horizontal	Fundamental
<p style="text-align: center;">Peak</p>	 <p>Site : 03CH5-HY Condition : PEAK_BE_74 3m 91200_15_1620 HORIZONTAL Detector : Peak Project : 9D0635</p>	 <p>Site : 03CH5-HY Condition : PEAK(UNIT) 3m 91200_15_1620 HORIZONTAL Detector : Peak Project : 9D0635</p>
<p style="text-align: center;">Avg.</p>	 <p>Site : 03CH5-HY Condition : AVG_BE_54 3m 91200_15_1620 HORIZONTAL Detector : Peak Project : 9D0635</p>	<p style="text-align: center;">Left blank</p>

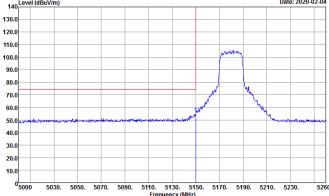

ANT	11ax(n20)_Tx_Ch01+11ax(20)_Tx_Ch36 - L	
Simultaneously	Vertical	Fundamental
<p style="text-align: center;">Peak</p>	 <p>Site : 03CH5-HY Condition : PEAK_BE_74 3m 91200_15_1620 VERTICAL Detector : Peak Project : 900635</p>	 <p>Site : 03CH5-HY Condition : PEAK(UNIT) 3m 91200_15_1620 VERTICAL Detector : Peak Project : 900635</p>
<p style="text-align: center;">Avg.</p>	 <p>Site : 03CH5-HY Condition : AVG_BE_54 3m 91200_15_1620 VERTICAL Detector : Peak Project : 900635</p>	<p style="text-align: center;">Left blank</p>



BT_Tx_Ch78+11ax(HE20)_Tx_Ch01+11ax(HE20)_Tx_Ch36 (Band Edge @ 3m)

ANT	BT_Tx_Ch78+11ax(HE20)_Tx_Ch01+11ax(HE20)_Tx_Ch36 - R	
Simultaneously	Horizontal	Fundamental
<p style="text-align: center;">Peak</p>	<p>Site : 03CH15-HY Condition : PEAK_BE_74 3m 91200_15_1620 HORIZONTAL RBW:1000.000kHz VBW:3000.000kHz SW1:Auto Detector : Peak Project : 9D0635</p>	<p>Site : 03CH15-HY Condition : PEAK_74 3m 91200_15_1620 HORIZONTAL RBW:1000.000kHz VBW:3000.000kHz SW1:Auto Detector : Peak Project : 9D0635</p>

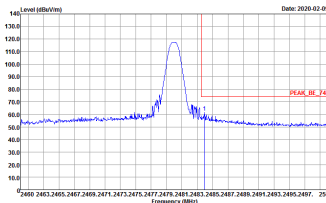
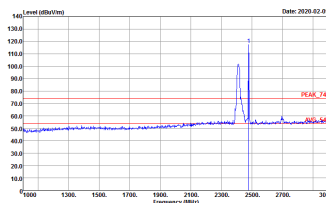

ANT	BT_Tx_Ch78+11ax(HE20)_Tx_Ch01+11ax(HE20)_Tx_Ch36 - R	
Simultaneously	Vertical	Fundamental
<p style="text-align: center;">Peak</p>	 <p>Site : 03CH5-HY Condition : PEAK_95_74 3m 91200_15_1620 VERTICAL Detector : Peak Project : 900635</p>	 <p>Site : 03CH5-HY Condition : PEAK_74 3m 91200_15_1620 VERTICAL Detector : Peak Project : 900635</p>

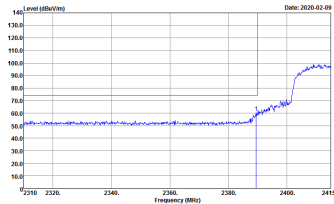
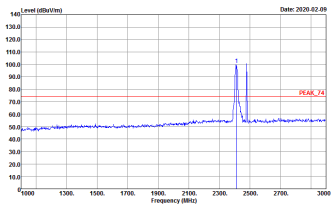
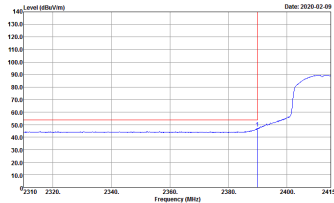
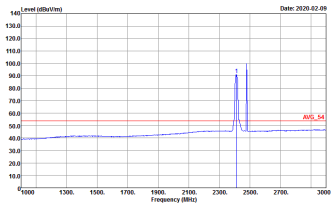

BT_Tx_Ch78+11ax(HE20)_Tx_Ch01+11ax(HE20)_Tx_Ch36 (Band Edge @ 3m)

ANT	BT_Tx_Ch78+11ax(HE20)_Tx_Ch01+11ax(HE20)_Tx_Ch36 - L	
Simultaneously	Horizontal	Fundamental
<p>Peak</p>	 <p>Site : 03CH5-HY Condition : PEAK_BE_74 3m 91200_15_1620 HORIZONTAL Detector : Peak Project : 9D0635</p>	 <p>Site : 03CH5-HY Condition : PEAK_74 3m 91200_15_1620 HORIZONTAL Detector : Peak Project : 9D0635</p>
<p>Avg.</p>	 <p>Site : 03CH5-HY Condition : AVG_BE_54 3m 91200_15_1620 HORIZONTAL Detector : Peak Project : 9D0635</p>	 <p>Site : 03CH5-HY Condition : AVG_54 3m 91200_15_1620 HORIZONTAL Detector : Peak Project : 9D0635</p>

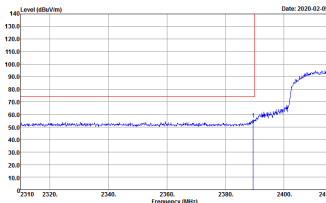
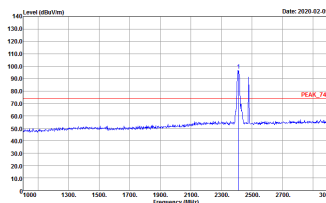
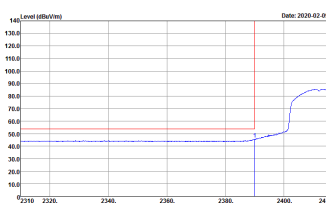
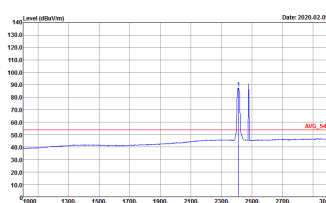

ANT	BT_Tx_Ch78+11ax(HE20)_Tx_Ch01+11ax(HE20)_Tx_Ch36 - L	
Simultaneously	Vertical	Fundamental
<p style="text-align: center;">Peak</p>	 <p style="font-size: small;">Date: 2020-02-09</p> <p>Site : 03CH15-HY Condition : PEAK_BE_74 3m 91200_15_1620 VERTICAL : RBW:1000.000kHz VBW:3000.000kHz SWT:Auto Detector : Peak Project : 9D0635</p>	 <p style="font-size: small;">Date: 2020-02-09</p> <p>Site : 03CH15-HY Condition : PEAK_74 3m 91200_15_1620 VERTICAL : RBW:1000.000kHz VBW:3000.000kHz SWT:Auto Detector : Peak Project : 9D0635</p>
<p style="text-align: center;">Avg.</p>	 <p style="font-size: small;">Date: 2020-02-09</p> <p>Site : 03CH15-HY Condition : AVG_BE_54 3m 91200_15_1620 VERTICAL : RBW:1000.000kHz VBW:1.000kHz SWT:Auto Detector : Peak Project : 9D0635</p>	 <p style="font-size: small;">Date: 2020-02-09</p> <p>Site : 03CH15-HY Condition : AVG_54 3m 91200_15_1620 VERTICAL : RBW:1000.000kHz VBW:1.000kHz SWT:Auto Detector : Peak Project : 9D0635</p>



BT_Tx_Ch78+11ax(HE20)_Tx_Ch01+11ax(HE20)_Tx_Ch36 (Band Edge @ 3m)

ANT	BT_Tx_Ch78+11ax(HE20)_Tx_Ch01+11ax(HE20)_Tx_Ch36 - L	
Simultaneously	Horizontal	Fundamental
<p style="text-align: center;">Peak</p>	 <p>Site : 03CH15-HY Condition : PEAK_BE_74 3m 91200_15_1620 HORIZONTAL Detector : Peak Project : 9D0635</p>	 <p>Site : 03CH15-HY Condition : PEAK(UNIT) 3m 91200_15_1620 HORIZONTAL Detector : Peak Project : 9D0635</p>
<p style="text-align: center;">Avg.</p>	 <p>Site : 03CH15-HY Condition : AVG_BE_54 3m 91200_15_1620 HORIZONTAL Detector : Peak Project : 9D0635</p>	<p style="text-align: center;">Left blank</p>

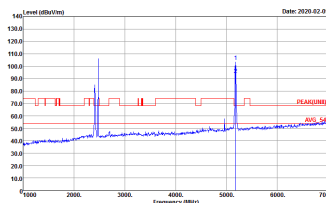
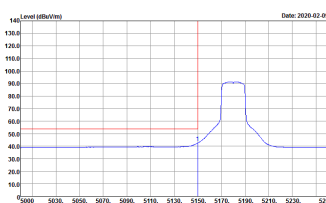

ANT	BT_Tx_Ch78+11ax(HE20)_Tx_Ch01+11ax(HE20)_Tx_Ch36 - L	
Simultaneously	Vertical	Fundamental
<p style="text-align: center;">Peak</p>	 <p>Site : 03CH5-HY Condition : PEAK_BE_74 3m 91200_15_1620 VERTICAL Detector : Peak Project : 900635</p>	 <p>Site : 03CH5-HY Condition : PEAK(UNT) 3m 91200_15_1620 VERTICAL Detector : Peak Project : 900635</p>
<p style="text-align: center;">Avg.</p>	 <p>Site : 03CH5-HY Condition : AVG_BE_54 3m 91200_15_1620 VERTICAL Detector : Peak Project : 900635</p>	<p style="text-align: center;">Left blank</p>



BLE_Tx_Ch00+11ax(HE20)_Tx_Ch01+11ax(HE20)_Tx_Ch36 (Band Edge @ 3m)

ANT	BLE_Tx_Ch00+11ax(HE20)_Tx_Ch01+11ax(HE20)_Tx_Ch36 - L	
Simultaneously	Horizontal	Fundamental
<p>Peak</p>	 <p>Site : 03CH15-HY Condition : PEAK_BE_74 3m 91200_15_1620 HORIZONTAL Detector : Peak Project : 900635 BLE Setting : 19 2.4G WLAN setting : 18.5 5G WLAN Setting : 17.5</p>	 <p>Site : 03CH15-HY Condition : PEAK_74 3m 91200_15_1620 HORIZONTAL Detector : Peak Project : 900635 BLE Setting : 19 2.4G WLAN setting : 18.5 5G WLAN Setting : 17.5</p>
<p>Avg.</p>	 <p>Site : 03CH15-HY Condition : AVG_BE_74 3m 91200_15_1620 HORIZONTAL Detector : Peak Project : 900635 BLE Setting : 19 2.4G WLAN setting : 18.5 5G WLAN Setting : 17.5</p>	 <p>Site : 03CH15-HY Condition : AVG_74 3m 91200_15_1620 HORIZONTAL Detector : Peak Project : 900635 BLE Setting : 19 2.4G WLAN setting : 18.5 5G WLAN Setting : 17.5</p>

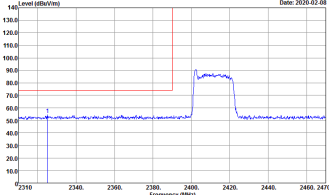
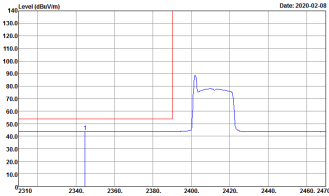
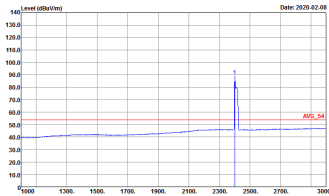

ANT	BLE_Tx_Ch00+11ax(HE20)_Tx_Ch01+11ax(HE20)_Tx_Ch36 - L	
Simultaneously	Vertical	Fundamental
Peak	 <p>Date: 2020-02-08</p> <p>Site : 03CH15-HY Condition : PEAK_BE_74 3m 91200_15_1620 VERTICAL Detector : Peak Project : 900635 BLE Setting : -9 2.4G WLAN setting : 18.5 5G WLAN Setting : 17.5</p>	 <p>Date: 2020-02-08</p> <p>Site : 03CH15-HY Condition : PEAK_74 3m 91200_15_1620 VERTICAL Detector : Peak Project : 900635 BLE Setting : -9 2.4G WLAN setting : 18.5 5G WLAN Setting : 17.5</p>
Avg.	 <p>Date: 2020-02-08</p> <p>Site : 03CH15-HY Condition : AVG_BE_74 3m 91200_15_1620 VERTICAL Detector : Peak Project : 900635 BLE Setting : -9 2.4G WLAN setting : 18.5 5G WLAN Setting : 17.5</p>	 <p>Date: 2020-02-08</p> <p>Site : 03CH15-HY Condition : AVG_74 3m 91200_15_1620 VERTICAL Detector : Peak Project : 900635 BLE Setting : -9 2.4G WLAN setting : 18.5 5G WLAN Setting : 17.5</p>

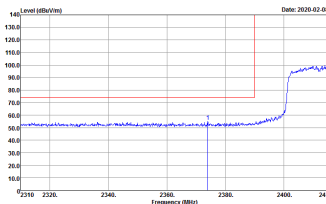
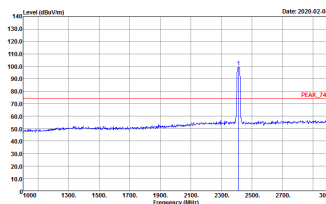

2.4GHz 2400~2483.5MHz (Band Edge @ 3m)

ANT	BLE_Tx_Ch00+11ax(HE20)_Tx_Ch01+11ax(HE20)_Tx_Ch36 - L	
Simultaneously	Horizontal	Fundamental
<p style="text-align: center;">Peak</p>	 <p>Site : 03CH15-HY Condition : PEAK_BE_74 3m 91200_15_1620 HORIZONTAL Detector : Peak Project : 900635 BLE Setting : 19 2.4G WLAN setting : 18.5 5G WLAN setting : 17.5</p>	 <p>Site : 03CH15-HY Condition : PEAK_74 3m 91200_15_1620 HORIZONTAL Detector : Peak Project : 900635 BLE Setting : 19 2.4G WLAN setting : 18.5 5G WLAN setting : 17.5</p>
<p style="text-align: center;">Avg.</p>	 <p>Site : 03CH15-HY Condition : AVG_BE_74 3m 91200_15_1620 HORIZONTAL Detector : Peak Project : 900635 BLE Setting : 19 2.4G WLAN setting : 18.5 5G WLAN setting : 17.5</p>	 <p>Site : 03CH15-HY Condition : AVG_74 3m 91200_15_1620 HORIZONTAL Detector : Peak Project : 900635 BLE Setting : 19 2.4G WLAN setting : 18.5 5G WLAN setting : 17.5</p>



ANT	BLE_Tx_Ch00+11ax(HE20)_Tx_Ch01+11ax(HE20)_Tx_Ch36 - L	
Simultaneously	Vertical	Fundamental
Peak	 <p>Site : 03CH15-HV Condition : PEAK_9C_74 3m 91200_15_1620 VERTICAL Detector : Peak Project : 900635 BLE Setting : 9 2.4G WLAN setting : 18.5 5G WLAN setting : 17.5</p>	 <p>Site : 03CH15-HV Condition : PEAK_74 3m 91200_15_1620 VERTICAL Detector : Peak Project : 900635 BLE Setting : 9 2.4G WLAN setting : 18.5 5G WLAN setting : 17.5</p>
Avg.	 <p>Site : 03CH15-HV Condition : AVG_BE_54 3m 91200_15_1620 VERTICAL Detector : Peak Project : 900635 BLE Setting : 9 2.4G WLAN setting : 18.5 5G WLAN setting : 17.5</p>	 <p>Site : 03CH15-HV Condition : AVG_54 3m 91200_15_1620 VERTICAL Detector : Peak Project : 900635 BLE Setting : 9 2.4G WLAN setting : 18.5 5G WLAN setting : 17.5</p>

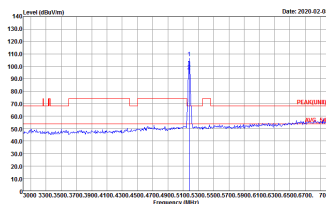

5GHz Band 3 - 5470~5725MHz (Band Edge @ 3m)

ANT	BLE_Tx_Ch00+11ax(HE20)_Tx_Ch01+11ax(HE20)_Tx_Ch36 - L	
Simultaneously	Horizontal	Fundamental
<p style="text-align: center;">Peak</p>	 <p>Site : 03CH15-HV Condition : PEAK_BE_74 3m 91200_15_1620 HORIZONTAL Detector : Peak Project : 900635 BLE Setting : 19 2.4G WLAN setting : 18.5 5G WLAN Setting : 17.5</p>	 <p>Site : 03CH15-HV Condition : PEAK(UNIT) 3m 91200_15_1620 HORIZONTAL Detector : Peak Project : 900635 BLE Setting : 19 2.4G WLAN setting : 18.5 5G WLAN Setting : 17.5</p>
<p style="text-align: center;">Avg.</p>	 <p>Site : 03CH15-HV Condition : AVG_BE_74 3m 91200_15_1620 HORIZONTAL Detector : Peak Project : 900635 BLE Setting : 19 2.4G WLAN setting : 18.5 5G WLAN Setting : 17.5</p>	<p style="text-align: center;">Left blank</p>



ANT	BLE_Tx_Ch00+11ax(HE20)_Tx_Ch01+11ax(HE20)_Tx_Ch36- L	
Simultaneously	Vertical	Fundamental
Peak	 <p>Site : 03CH15-HV Condition : PEAK_BE_74 3m 91200_15_1620 VERTICAL Detector : Peak Project : 900635 BLE Setting : 9 2.4G WLAN setting : 18.5 5G WLAN Setting : 17.5</p>	 <p>Site : 03CH15-HV Condition : PEAK(04E1) 3m 91200_15_1620 VERTICAL Detector : Peak Project : 900635 BLE Setting : 9 2.4G WLAN setting : 18.5 5G WLAN Setting : 17.5</p>
Avg.	 <p>Site : 03CH15-HV Condition : AVG_BE_54 3m 91200_15_1620 VERTICAL Detector : Peak Project : 900635 BLE Setting : 9 2.4G WLAN setting : 18.5 5G WLAN Setting : 17.5</p>	Left blank

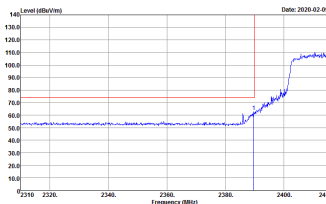
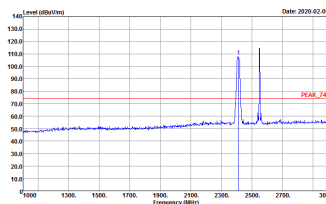
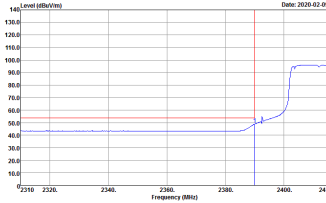
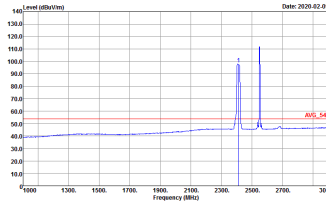

2.4GHz 2400~2483.5MHz (Band Edge @ 3m)

ANT	LTE Band 7 BW 20M+11ax(HE20)_Tx_Ch01 - L	
Simultaneously	Horizontal	Fundamental
<p style="text-align: center;">Peak</p>	 <p>Site : 03CH5-HY Condition : PEAK_BE_74 3m 91200_15_1620 HORIZONTAL Detector : Peak Project : 900635 Setting : 15.5</p>	 <p>Site : 03CH5-HY Condition : PEAK_F4 3m 91200_15_1620 HORIZONTAL Detector : Peak Project : 900635 Setting : 15.5</p>
<p style="text-align: center;">Avg.</p>	 <p>Site : 03CH5-HY Condition : AVG_BE_54 3m 91200_15_1620 HORIZONTAL Detector : Peak Project : 900635 Setting : 15.5</p>	 <p>Site : 03CH5-HY Condition : AVG_F4 3m 91200_15_1620 HORIZONTAL Detector : Peak Project : 900635 Setting : 15.5</p>

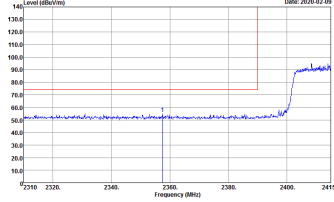
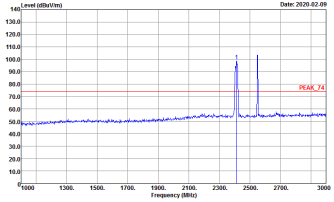
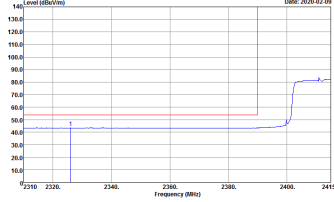
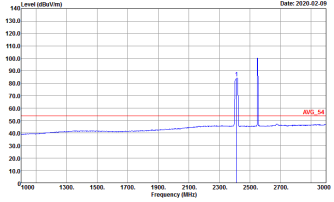

ANT	LTE Band 7 BW 20M+11ax(HE20)_Tx_Ch01 - L	
Simultaneously	Vertical	Fundamental
<p style="text-align: center;">Peak</p>	 <p>Site : 03CH5-HY Condition : PEAK_BE_74 3m 91200_15_1620 VERTICAL Detector : Peak Project : 900635 Setting : 15.5</p>	 <p>Site : 03CH5-HY Condition : PEAK_74 3m 91200_15_1620 VERTICAL Detector : Peak Project : 900635 Setting : 15.5</p>
<p style="text-align: center;">Avg.</p>	 <p>Site : 03CH5-HY Condition : AVG_BE_54 3m 91200_15_1620 VERTICAL Detector : Peak Project : 900635 Setting : 15.5</p>	 <p>Site : 03CH5-HY Condition : AVG_54 3m 91200_15_1620 VERTICAL Detector : Peak Project : 900635 Setting : 15.5</p>

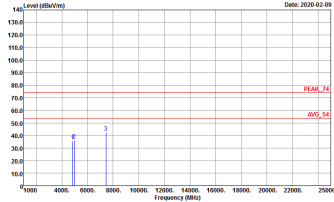
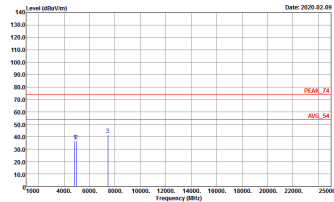

BT_Tx_Ch78+11ax(HE20)_Tx_Ch01 (Harmonic @ 3m)

ANT	BT_Tx_Ch78+11ax(HE20)_Tx_Ch01	
Simultaneously	Horizontal	Vertical
<p style="text-align: center;">Peak Avg.</p>	 <p>Site : 03CH5-HY Condition : PEAK_T4 3m 91200_15_1620 HORIZONTAL Detector : Peak Project : 9D0635</p>	 <p>Site : 03CH5-HY Condition : PEAK_T4 3m 91200_15_1620 VERTICAL Detector : Peak Project : 9D0635</p>

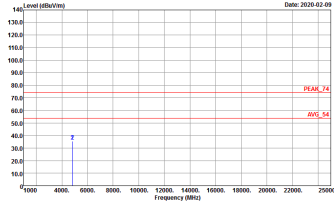
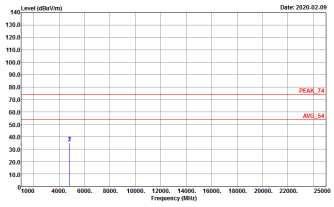

BLE_Tx_Ch00+11ax(20)_Tx_Ch01 (Harmonic @ 3m)

ANT	BLE_Tx_Ch00+11ax(20)_Tx_Ch01	
Simultaneously	Horizontal	Vertical
<p style="text-align: center;">Peak Avg.</p>	 <p>Site : 03CH15-FY Condition : PEAK_74 3m 91200_15_1620 HORIZONTAL Detector : Peak Project : 9D0635</p>	 <p>Site : 03CH15-FY Condition : PEAK_74 3m 91200_15_1620 VERTICAL Detector : Peak Project : 9D0635</p>

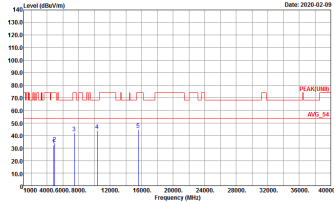
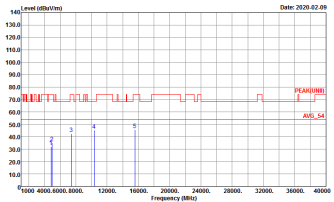

BT_Tx_Ch00+11ax(HE20)_Tx_Ch36 (Harmonic @ 3m)

ANT	BT_Tx_Ch00+11ax(HE20)_Tx_Ch36	
Simultaneously	Horizontal	Vertical
<p>Peak Avg.</p>	 <p>Site : 03CH15-HY Condition : PEAK(AVGT) 3m 91200_15_1620 HORIZONTAL Detector : Peak Project : 9D0635</p>	 <p>Site : 03CH15-HY Condition : PEAK(AVGT) 3m 91200_15_1620 VERTICAL Detector : Peak Project : 9D0635</p>

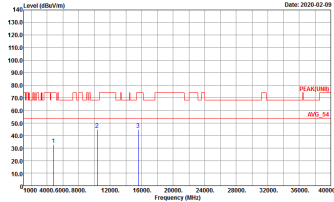
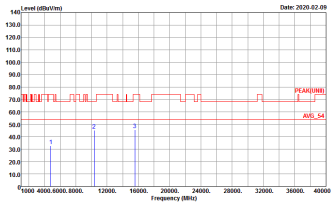

BLE_Tx_Ch00+11ax(HE20)_Tx_Ch36 (Harmonic @ 3m)

ANT	BLE_Tx_Ch00+11ax(HE20)_Tx_Ch36	
Simultaneously	Horizontal	Vertical
<p style="text-align: center;">Peak Avg.</p>	 <p>Site : 03CH15-HY Condition : PEAK(UNIT) 3m 91200_15_1620 HORIZONTAL Detector : Peak Project : 9D0635</p>	 <p>Site : 03CH15-HY Condition : PEAK(UNIT) 3m 91200_15_1620 VERTICAL Detector : Peak Project : 9D0635</p>



11ax(n20)_Tx_Ch01+11ax(20)_Tx_Ch36 (Harmonic @ 3m)

ANT	11ax(n20)_Tx_Ch01+11ax(20)_Tx_Ch36	
Simultaneously	Horizontal	Vertical
<p>Peak Avg.</p>	<p>Site : 03CH15-HY Condition : PEAK(UNIT) 3m 91200_15_1620 HORIZONTAL Detector : Peak Project : 9D0635</p>	<p>Site : 03CH15-HY Condition : PEAK(UNIT) 3m 91200_15_1620 VERTICAL Detector : Peak Project : 9D0635</p>



BT_Tx_Ch78+11ax(HE20)_Tx_Ch01+11ax(HE20)_Tx_Ch36 (Harmonic @ 3m)

ANT	BT_Tx_Ch78+11ax(HE20)_Tx_Ch01+11ax(HE20)_Tx_Ch36	
Simultaneously	Horizontal	Vertical
<p style="text-align: center;">Peak Avg.</p>	<p>Site : 03CH5-HY Condition : PEAK(UNIT) 3m 91200_15_1620 HORIZONTAL Detector : Peak Project : 9D0635</p>	<p>Site : 03CH5-HY Condition : PEAK(UNIT) 3m 91200_15_1620 VERTICAL Detector : Peak Project : 9D0635</p>



BLE_Tx_Ch00+11ax(HE20)_Tx_Ch01+11ax(HE20)_Tx_Ch36 (Harmonic @ 3m)

ANT	BLE_Tx_Ch00+11ax(HE20)_Tx_Ch01+11ax(HE20)_Tx_Ch36	
Simultaneously	Horizontal	Vertical
<p style="text-align: center;">Peak Avg.</p>		



Appendix C. Duty Cycle Plots

DH5 on time (One Pulse) Plot on Channel 39

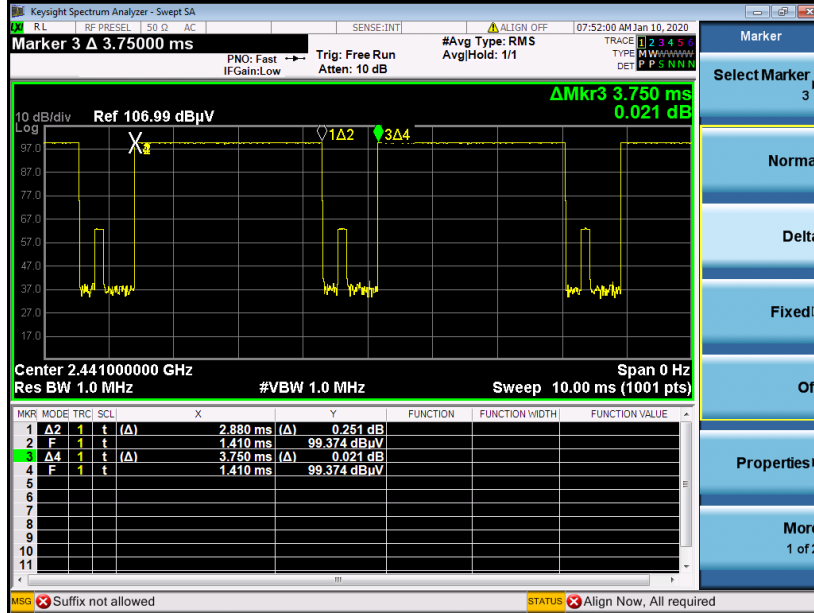

on time (Count Pulses) Plot on Channel 39

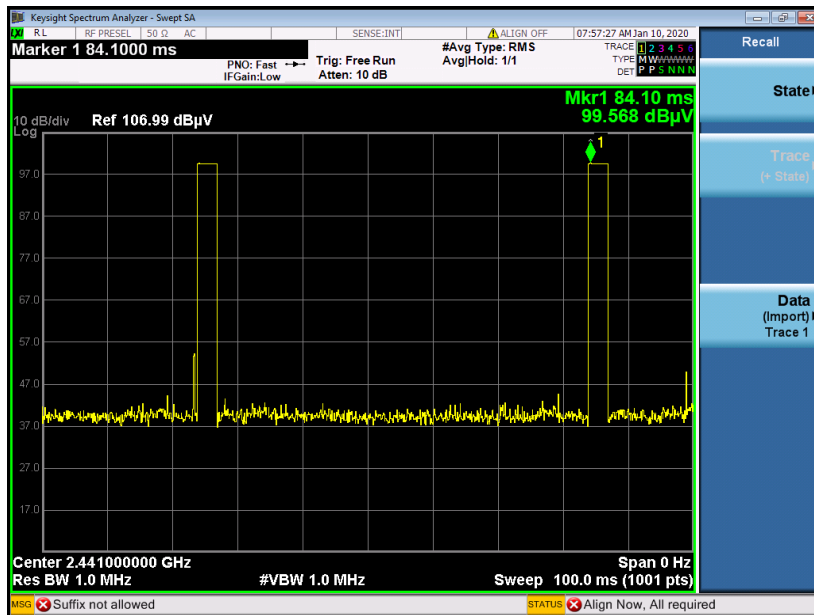

Note:

1. Worst case Duty cycle = on time/100 milliseconds = $2 * 2.88 / 100 = 5.76 \%$
2. Worst case Duty cycle correction factor = $20 * \log(\text{Duty cycle}) = -24.79 \text{ dB}$
3. DH5 has the highest duty cycle worst case and is reported.



Duty Cycle Correction Factor Consideration for AFH mode:

Bluetooth normal hopping rate is 1600Hz and reduced to 800Hz in AFH mode; due to the reduced number of hopping frequencies, with the same packet configuration the dwell time in each channel frequency within 100msec period is longer in AFH mode than normal mode.

In AFH mode, the minimum hopping frequencies are 20, to get the longest dwell time DH5 packet is observed; the period to have DH5 packet completing one hopping sequence is

$$2.88 \text{ ms} \times 20 \text{ channels} = 57.6 \text{ ms}$$

There cannot be 2 complete hopping sequences within 100ms period, considering the random hopping behavior, maximum 2 hops can be possibly observed within the period. $[100\text{ms} / 57.6\text{ms}] = 2$ hops

Thus, the maximum possible ON time:

$$2.88 \text{ ms} \times 2 = 5.76 \text{ ms}$$

Worst case Duty Cycle Correction factor, which is derived from the maximum possible ON time,

$$20 \times \log(5.76 \text{ ms}/100\text{ms}) = -24.79 \text{ dB}$$



Antenna	Band	Duty Cycle(%)	T(us)	1/T(kHz)	VBW Setting	Duty Factor(dB)
1	Bluetooth –LE for 2Mbps	32.1	200	5.00	10kHz	4.93
2	2.4GHz 802.11n HT20	100.00	-	-	10Hz	0.00
2	2.4GHz 802.11ax HE 20	100.00	-	-	10Hz	0.00
1+2	2.4GHz 802.11ax HE 20 for Ant1	100.00	-	-	10Hz	0.00
1+2	2.4GHz 802.11ax HE 20 for Ant2	100.00	-	-	10Hz	0.00
1+2	5GHz 802.11ax HE20 for Ant 1	100.00	-	-	10Hz	0.00
1+2	5GHz 802.11ax HE20 for Ant 2	100.00	-	-	10Hz	0.00

Bluetooth – LE for 2Mbps

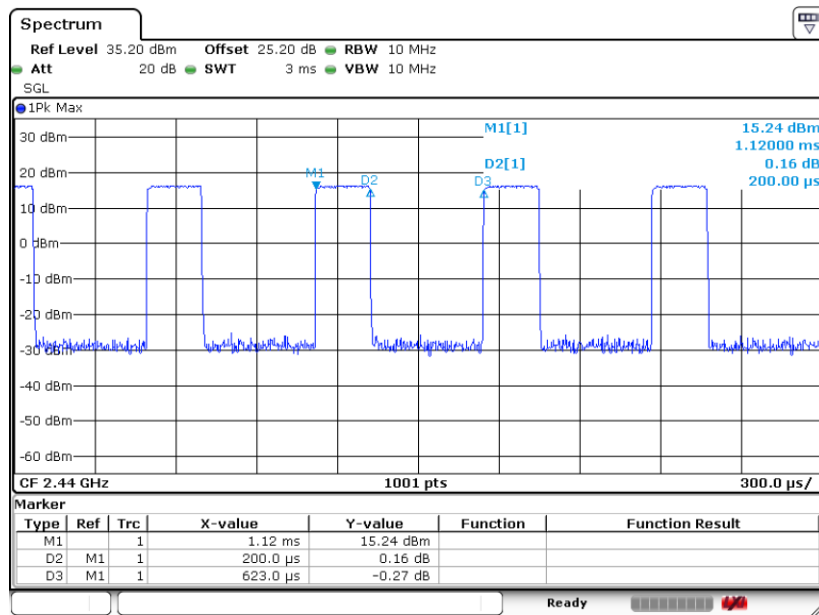

Date: 24.DEC.2019 00:32:32



<Ant. 2>

2.4GHz 802.11n HT20

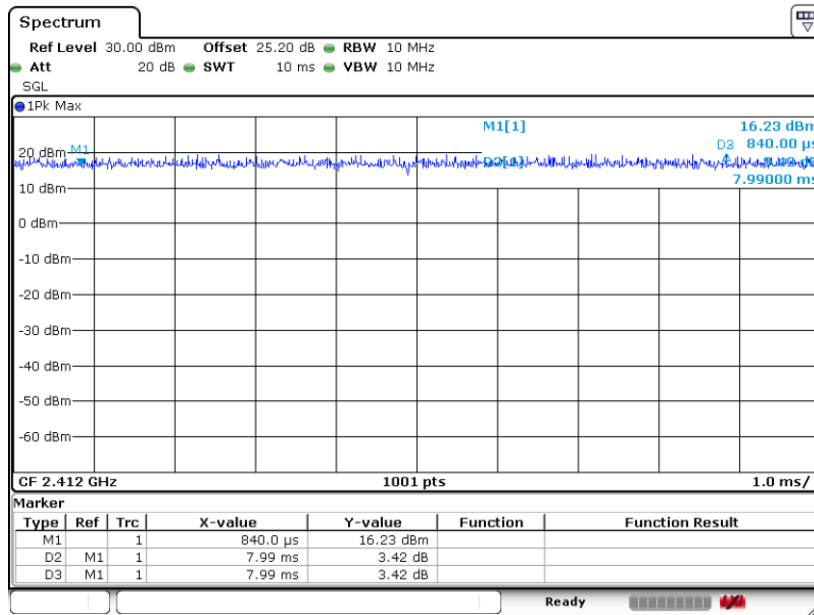

Date: 25.DEC.2019 23:17:42

2.4GHz 802.11ax HE20

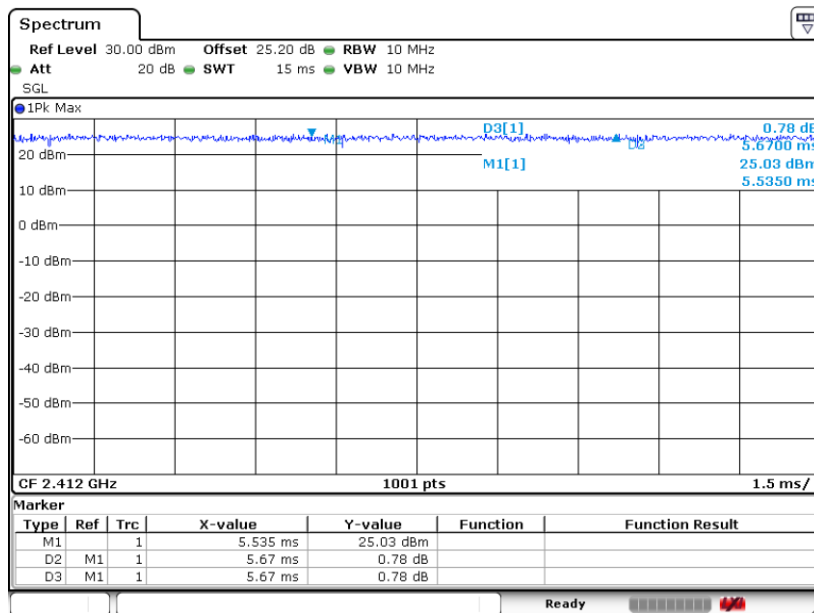

Date: 28.DEC.2019 03:05:10



MIMO <Ant. 1>

2.4GHZ 802.11ax HE20

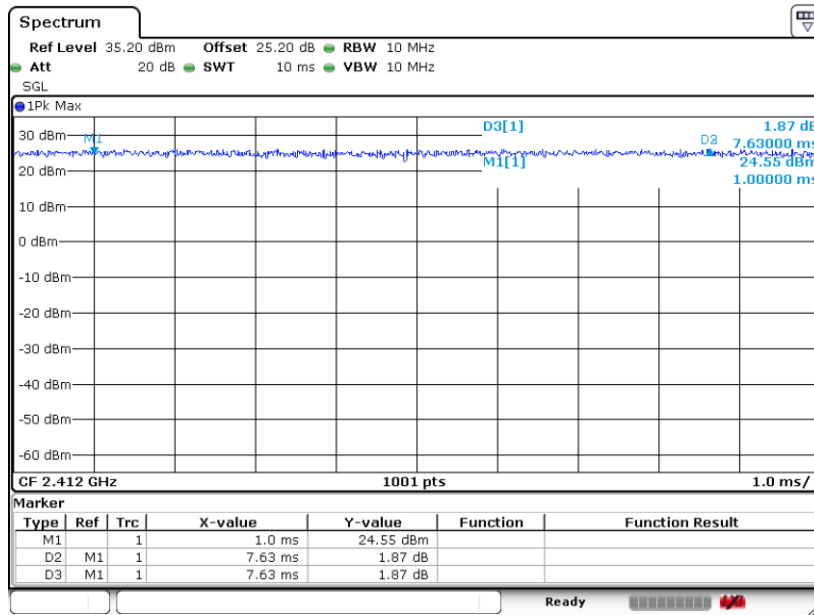

Date: 28.DEC.2019 03:07:36

5GHZ 802.11ax HE20

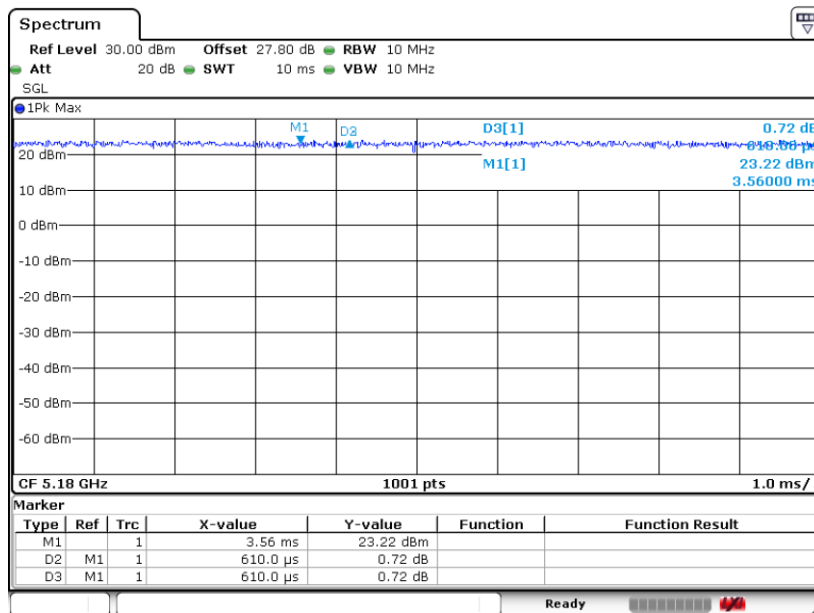

Date: 28.DEC.2019 01:14:58



MIMO <Ant. 2>

2.4GHZ 802.11ax HE20

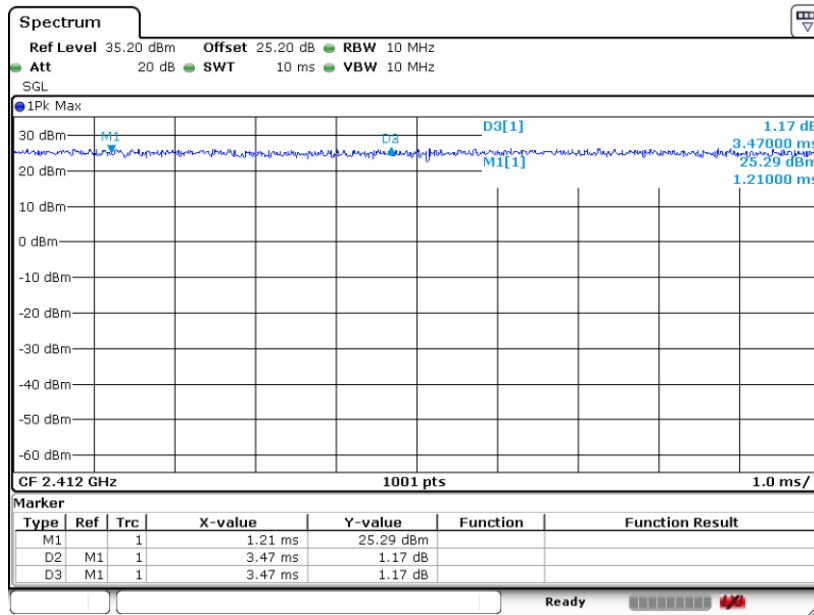

Date: 28.DEC.2019 03:08:14

5GHZ 802.11ax HE20

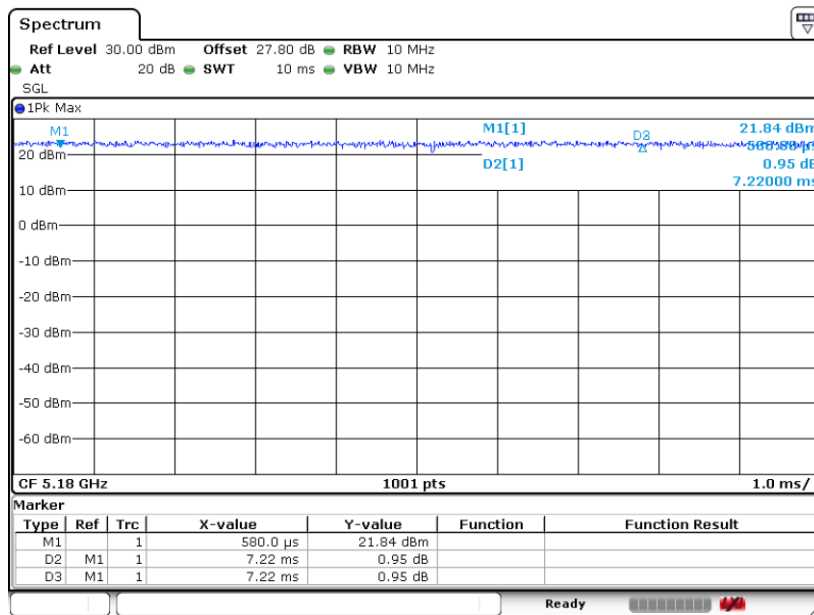

Date: 28.DEC.2019 01:15:50

— THE END —