

#01_GSM850_GPRS (2 Tx slots)_Right Cheek_Ch128

Communication System: GSM850; Frequency: 824.2 MHz; Duty Cycle: 1:4.15
Medium: HSL_850_190816 Medium parameters used: $f = 824.2$ MHz; $\sigma = 0.879$ S/m; $\epsilon_r = 42.295$;
 $\rho = 1000$ kg/m³
Ambient Temperature : 23.3 °C ; Liquid Temperature : 22.3 °C

DASY5 Configuration

- Probe: EX3DV4 - SN7346; ConvF(9.81, 9.81, 9.81) @ 824.2 MHz; Calibrated: 2019/4/25
- Sensor-Surface: 1.4mm (Mechanical Surface Detection)
- Electronics: DAE4 Sn1326; Calibrated: 2018/9/18
- Phantom: Twin-SAM V5.0 (30deg probe tilt); Type: QD 000 P40 CD; Serial: 1885
- Measurement SW: DASY52, Version 52.10 (2); SEMCAD X Version 14.6.12 (7450)

Area Scan (61x121x1): Interpolated grid: dx=1.500 mm, dy=1.500 mm
Maximum value of SAR (interpolated) = 0.152 W/kg

Zoom Scan (5x5x7)/Cube 0: Measurement grid: dx=8mm, dy=8mm, dz=5mm
Reference Value = 12.73 V/m; Power Drift = 0.16 dB
Peak SAR (extrapolated) = 0.168 W/kg
SAR(1 g) = 0.123 W/kg; SAR(10 g) = 0.092 W/kg
Maximum value of SAR (measured) = 0.150 W/kg

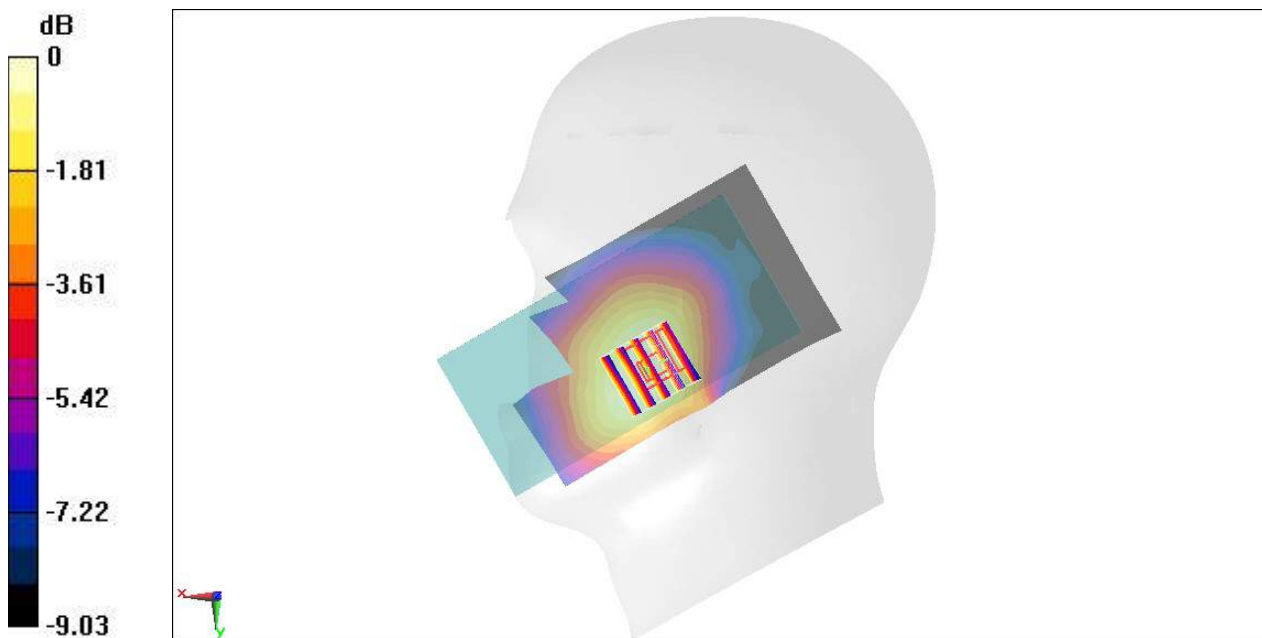

0 dB = 0.150 W/kg = -8.24 dBW/kg

#02_GSM1900_GPRS (2 Tx slots)_Left Cheek_Ch512

Communication System: PCS; Frequency: 1850.2 MHz; Duty Cycle: 1:4.15

Medium: HSL_1900_190815 Medium parameters used: $f = 1850.2$ MHz; $\sigma = 1.335$ S/m; $\epsilon_r = 40.551$; $\rho = 1000$ kg/m³

Ambient Temperature : 23.6 °C ; Liquid Temperature : 22.6 °C

DASY5 Configuration:

- Probe: EX3DV4 - SN3642; ConvF(7.91, 7.91, 7.91) @ 1850.2 MHz; Calibrated: 2019/4/29
- Sensor-Surface: 1.4mm (Mechanical Surface Detection)
- Electronics: DAE3 Sn360; Calibrated: 2018/10/29
- Phantom: SAM_Left; Type: QD000P40CD; Serial: TP:1815
- Measurement SW: DASY52, Version 52.10 (2); SEMCAD X Version 14.6.12 (7470)

Area Scan (61x121x1): Interpolated grid: dx=1.500 mm, dy=1.500 mm

Maximum value of SAR (interpolated) = 0.124 W/kg

Zoom Scan (5x5x7)/Cube 0: Measurement grid: dx=8mm, dy=8mm, dz=5mm

Reference Value = 7.542 V/m; Power Drift = 0.03 dB

Peak SAR (extrapolated) = 0.151 W/kg

SAR(1 g) = 0.103 W/kg; SAR(10 g) = 0.066 W/kg

Maximum value of SAR (measured) = 0.134 W/kg

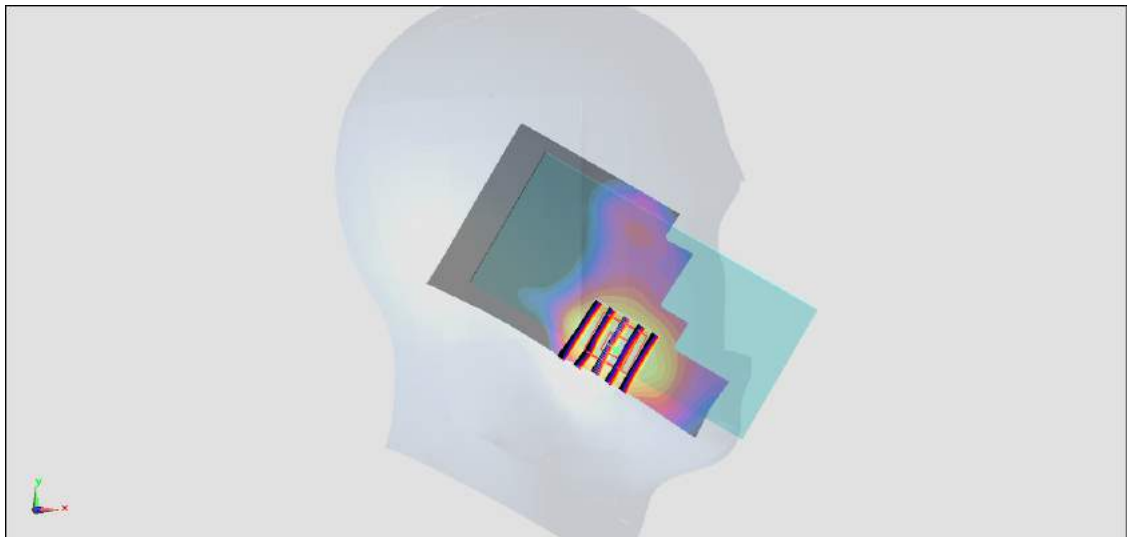
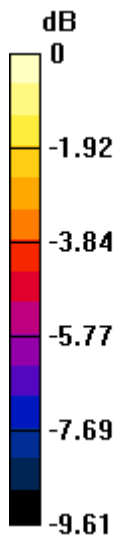

0 dB = 0.134 W/kg = -8.73 dBW/kg

#03_WCDMA II_RMC 12.2Kbps_Left Cheek_Ch9400

Communication System: WCDMA; Frequency: 1880 MHz; Duty Cycle: 1:1

Medium: HSL_1900_190815 Medium parameters used: $f = 1880$ MHz; $\sigma = 1.364$ S/m; $\epsilon_r = 40.455$; $\rho = 1000$ kg/m³

Ambient Temperature : 23.6 °C ; Liquid Temperature : 22.6 °C

DASY5 Configuration:

- Probe: EX3DV4 - SN3642; ConvF(7.91, 7.91, 7.91) @ 1880 MHz; Calibrated: 2019/4/29
- Sensor-Surface: 1.4mm (Mechanical Surface Detection)
- Electronics: DAE3 Sn360; Calibrated: 2018/10/29
- Phantom: SAM_Left; Type: QD000P40CD; Serial: TP:1815
- Measurement SW: DASY52, Version 52.10 (2); SEMCAD X Version 14.6.12 (7470)

Area Scan (61x121x1): Interpolated grid: dx=1.500 mm, dy=1.500 mm

Maximum value of SAR (interpolated) = 0.427 W/kg

Zoom Scan (5x5x7)/Cube 0: Measurement grid: dx=8mm, dy=8mm, dz=5mm

Reference Value = 14.88 V/m; Power Drift = -0.02 dB

Peak SAR (extrapolated) = 0.499 W/kg

SAR(1 g) = 0.308 W/kg; SAR(10 g) = 0.183 W/kg

Maximum value of SAR (measured) = 0.427 W/kg

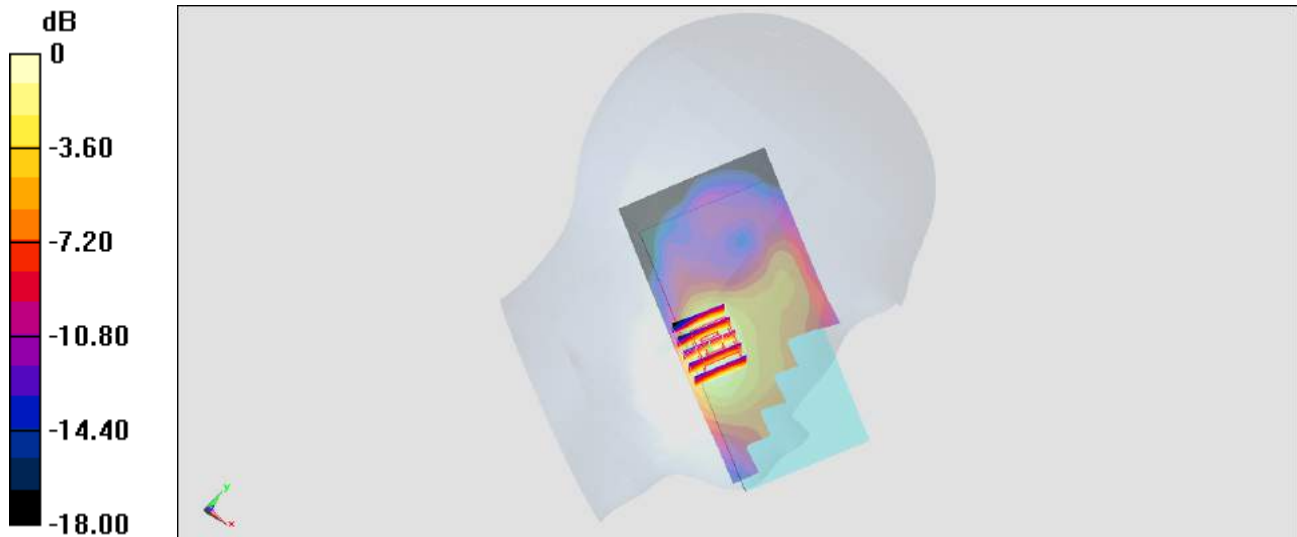

#04_WCDMA IV_RMC 12.2Kbps_Left Cheek_Ch1413

Communication System: WCDMA; Frequency: 1732.6 MHz; Duty Cycle: 1:1

Medium: HSL_1750_190815 Medium parameters used: $f = 1733$ MHz; $\sigma = 1.385$ S/m; $\epsilon_r = 40.779$; $\rho = 1000$ kg/m³

Ambient Temperature : 23.6 °C ; Liquid Temperature : 22.6 °C

DASY5 Configuration:

- Probe: EX3DV4 - SN3642; ConvF(8.18, 8.18, 8.18) @ 1732.6 MHz; Calibrated: 2019/4/29
- Sensor-Surface: 1.4mm (Mechanical Surface Detection)
- Electronics: DAE3 Sn360; Calibrated: 2018/10/29
- Phantom: SAM_Left; Type: QD000P40CD; Serial: TP:1815
- Measurement SW: DASY52, Version 52.10 (2); SEMCAD X Version 14.6.12 (7470)

Area Scan (61x121x1): Interpolated grid: dx=1.500 mm, dy=1.500 mm

Maximum value of SAR (interpolated) = 0.337 W/kg

Zoom Scan (5x5x7)/Cube 0: Measurement grid: dx=8mm, dy=8mm, dz=5mm

Reference Value = 13.44 V/m; Power Drift = -0.00 dB

Peak SAR (extrapolated) = 0.388 W/kg

SAR(1 g) = 0.257 W/kg; SAR(10 g) = 0.160 W/kg

Maximum value of SAR (measured) = 0.344 W/kg

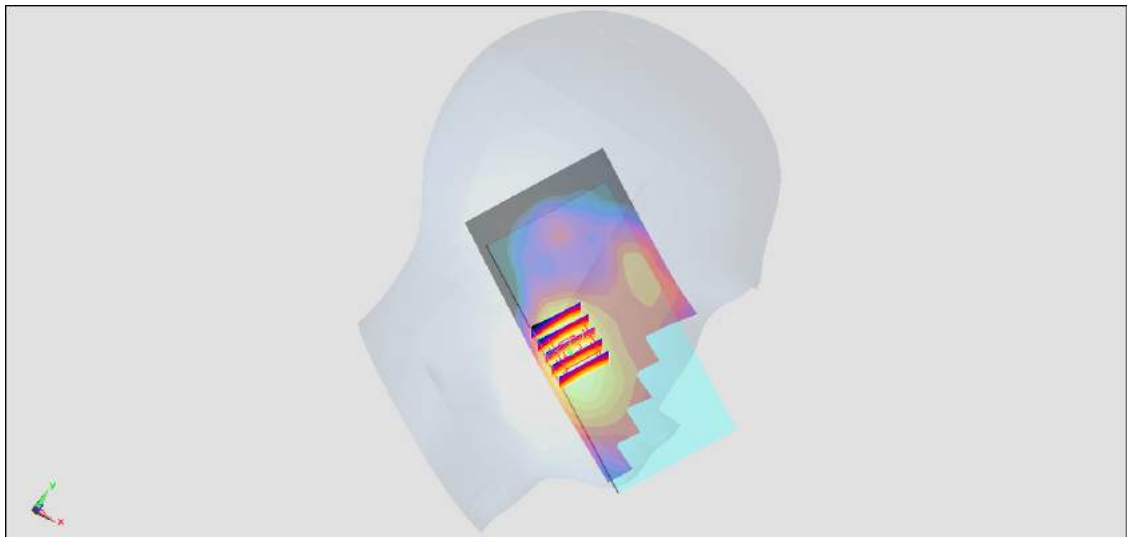
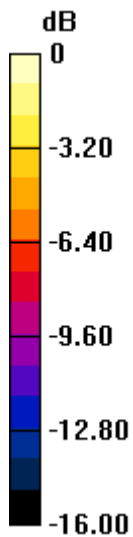

0 dB = 0.344 W/kg = -4.63 dBW/kg

#05_WCDMA V_RMC 12.2Kbps_Right Cheek_Ch4182

Communication System: WCDMA; Frequency: 836.4 MHz; Duty Cycle: 1:1

Medium: HSL_850_190808 Medium parameters used: $f = 836.4$ MHz; $\sigma = 0.886$ S/m; $\epsilon_r = 42.52$; $\rho = 1000$ kg/m³

Ambient Temperature : 23.5 °C; Liquid Temperature : 22.5 °C

DASY5 Configuration:

- Probe: ES3DV3 - SN3169; ConvF(6.42, 6.42, 6.42) @ 836.4 MHz; Calibrated: 2019/5/24
- Sensor-Surface: 3mm (Mechanical Surface Detection)
- Electronics: DAE4 Sn1326; Calibrated: 2018/9/18
- Phantom: Twin-SAM V5.0 (30deg probe tilt); Type: QD 000 P40 CD; Serial: 1885
- Measurement SW: DASY52, Version 52.10 (2); SEMCAD X Version 14.6.12 (7450)

Area Scan (61x121x1): Interpolated grid: dx=1.500 mm, dy=1.500 mm

Maximum value of SAR (interpolated) = 0.328 W/kg

Zoom Scan (5x5x7)/Cube 0: Measurement grid: dx=8mm, dy=8mm, dz=5mm

Reference Value = 19.73 V/m; Power Drift = 0.01 dB

Peak SAR (extrapolated) = 0.392 W/kg

SAR(1 g) = 0.268 W/kg; SAR(10 g) = 0.184 W/kg

Maximum value of SAR (measured) = 0.326 W/kg

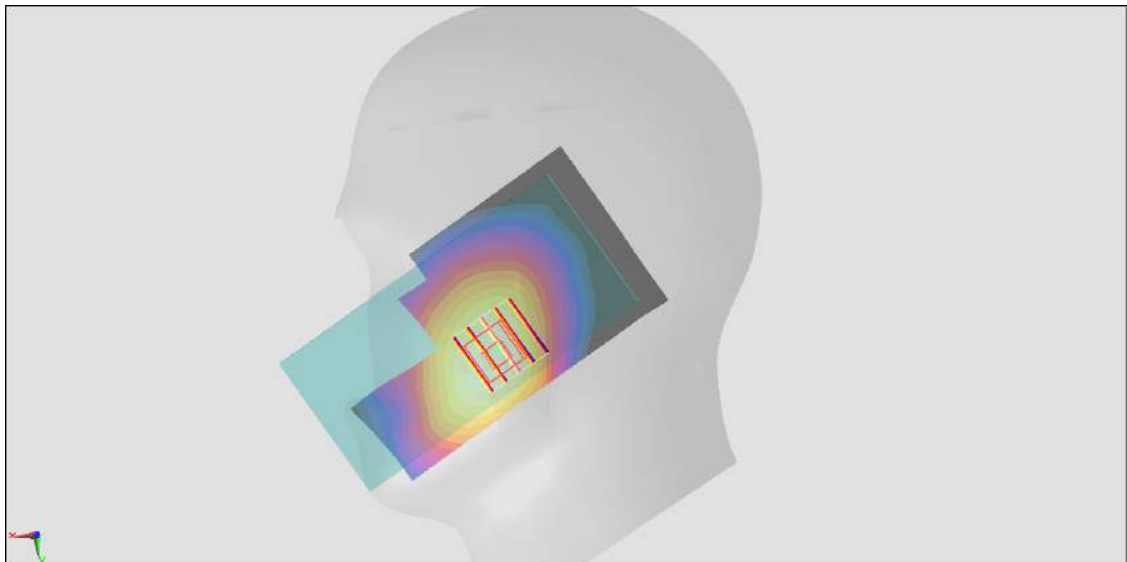
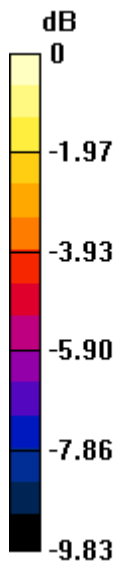

#06_LTE Band 2_20M_QPSK_1_49_Right Cheek_Ch19100

Communication System: LTE; Frequency: 1900 MHz; Duty Cycle: 1:1

Medium: HSL_1900_190815 Medium parameters used: $f = 1900$ MHz; $\sigma = 1.384$ S/m; $\epsilon_r = 40.37$; $\rho = 1000$ kg/m³

Ambient Temperature : 23.6 °C ; Liquid Temperature : 22.6 °C

DASY5 Configuration:

- Probe: EX3DV4 - SN3642; ConvF(7.91, 7.91, 7.91) @ 1900 MHz; Calibrated: 2019/4/29
- Sensor-Surface: 1.4mm (Mechanical Surface Detection)
- Electronics: DAE3 Sn360; Calibrated: 2018/10/29
- Phantom: SAM_Left; Type: QD000P40CD; Serial: TP:1815
- Measurement SW: DASY52, Version 52.10 (2); SEMCAD X Version 14.6.12 (7470)

Area Scan (61x121x1): Interpolated grid: dx=1.500 mm, dy=1.500 mm

Maximum value of SAR (interpolated) = 0.197 W/kg

Zoom Scan (5x5x7)/Cube 0: Measurement grid: dx=8mm, dy=8mm, dz=5mm

Reference Value = 11.35 V/m; Power Drift = 0.15 dB

Peak SAR (extrapolated) = 0.216 W/kg

SAR(1 g) = 0.134 W/kg; SAR(10 g) = 0.086 W/kg

Maximum value of SAR (measured) = 0.183 W/kg

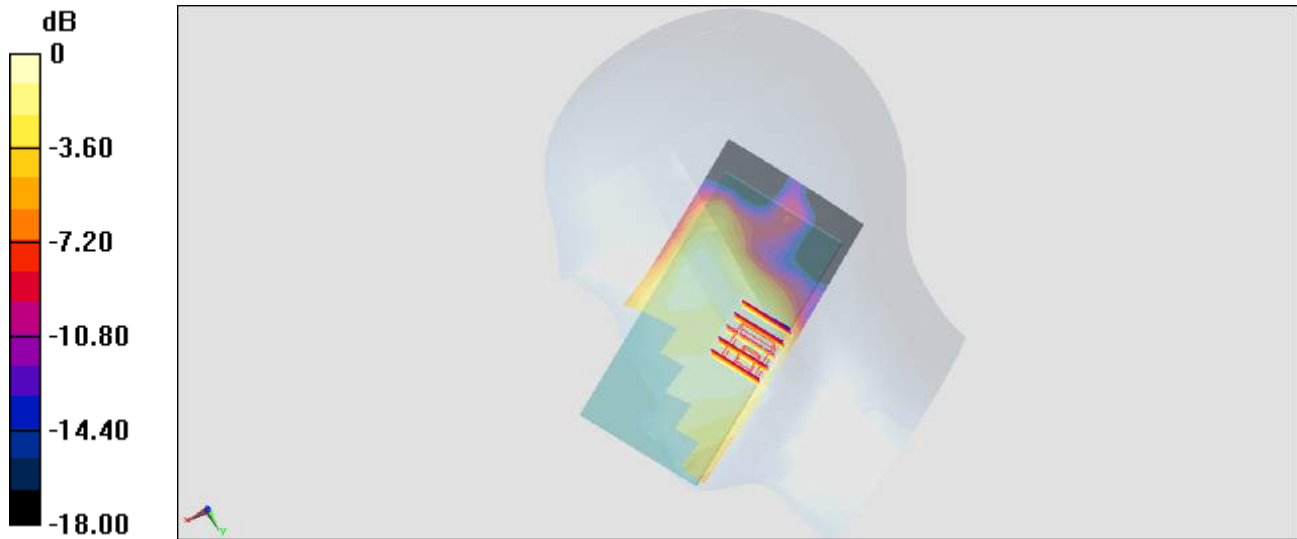

#07_LTE Band 4_20M_QPSK_1_0_Left Cheek_Ch20175

Communication System: LTE; Frequency: 1732.5 MHz; Duty Cycle: 1:1

Medium: HSL_1750_190815 Medium parameters used: $f = 1733$ MHz; $\sigma = 1.385$ S/m; $\epsilon_r = 40.779$; $\rho = 1000$ kg/m³

Ambient Temperature : 23.6 °C ; Liquid Temperature : 22.6 °C

DASY5 Configuration:

- Probe: EX3DV4 - SN3642; ConvF(8.18, 8.18, 8.18) @ 1732.5 MHz; Calibrated: 2019/4/29
- Sensor-Surface: 1.4mm (Mechanical Surface Detection)
- Electronics: DAE3 Sn360; Calibrated: 2018/10/29
- Phantom: SAM_Left; Type: QD000P40CD; Serial: TP:1815
- Measurement SW: DASY52, Version 52.10 (2); SEMCAD X Version 14.6.12 (7470)

Area Scan (61x121x1): Interpolated grid: dx=1.500 mm, dy=1.500 mm

Maximum value of SAR (interpolated) = 0.209 W/kg

Zoom Scan (5x5x7)/Cube 0: Measurement grid: dx=8mm, dy=8mm, dz=5mm

Reference Value = 9.442 V/m; Power Drift = 0.14 dB

Peak SAR (extrapolated) = 0.150 W/kg

SAR(1 g) = 0.105 W/kg; SAR(10 g) = 0.073 W/kg

Maximum value of SAR (measured) = 0.131 W/kg

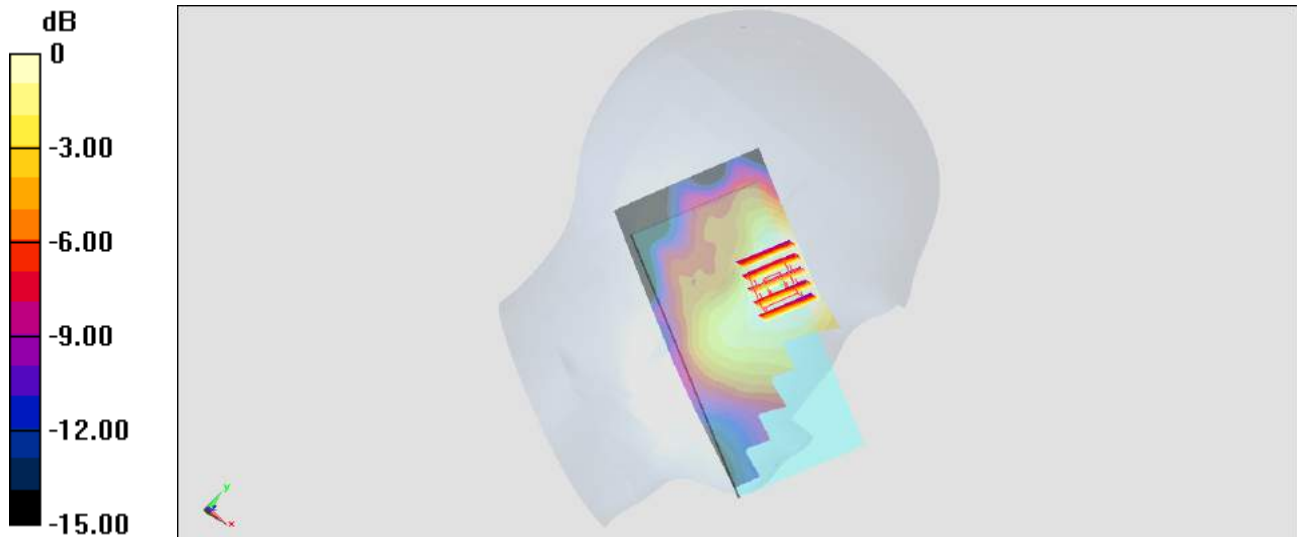

0 dB = 0.131 W/kg = -8.83 dBW/kg

#08_LTE Band 7_20M_QPSK_1_49_Right Tilted_Ch21100

Communication System: LTE ; Frequency: 2535 MHz;Duty Cycle: 1:1
Medium: HSL_2600_190814 Medium parameters used: $f = 2535$ MHz; $\sigma = 1.851$ S/m; $\epsilon_r = 38.609$;
 $\rho = 1000$ kg/m³
Ambient Temperature : 23.8 °C ; Liquid Temperature : 22.8 °C

DASY5 Configuration

- Probe: EX3DV4 - SN7346;ConvF(7.5, 7.5, 7.5) @ 2535 MHz;Calibrated: 2019/4/25
- Sensor-Surface: 1.4mm (Mechanical Surface Detection)
- Electronics: DAE4 Sn1326; Calibrated: 2018/9/18
- Phantom: Twin-SAM V5.0 (30deg probe tilt); Type: QD 000 P40 CD; Serial: 1885
- Measurement SW: DASY52, Version 52.10 (2); SEMCAD X Version 14.6.12 (7450)

Area Scan (81x151x1): Interpolated grid: dx=1.200 mm, dy=1.200 mm
Maximum value of SAR (interpolated) = 0.219 W/kg

Zoom Scan (7x7x7)/Cube 0: Measurement grid: dx=5mm, dy=5mm, dz=5mm
Reference Value = 5.919 V/m; Power Drift = 0.03 dB
Peak SAR (extrapolated) = 0.477 W/kg
SAR(1 g) = 0.258 W/kg; SAR(10 g) = 0.128 W/kg
Maximum value of SAR (measured) = 0.398 W/kg

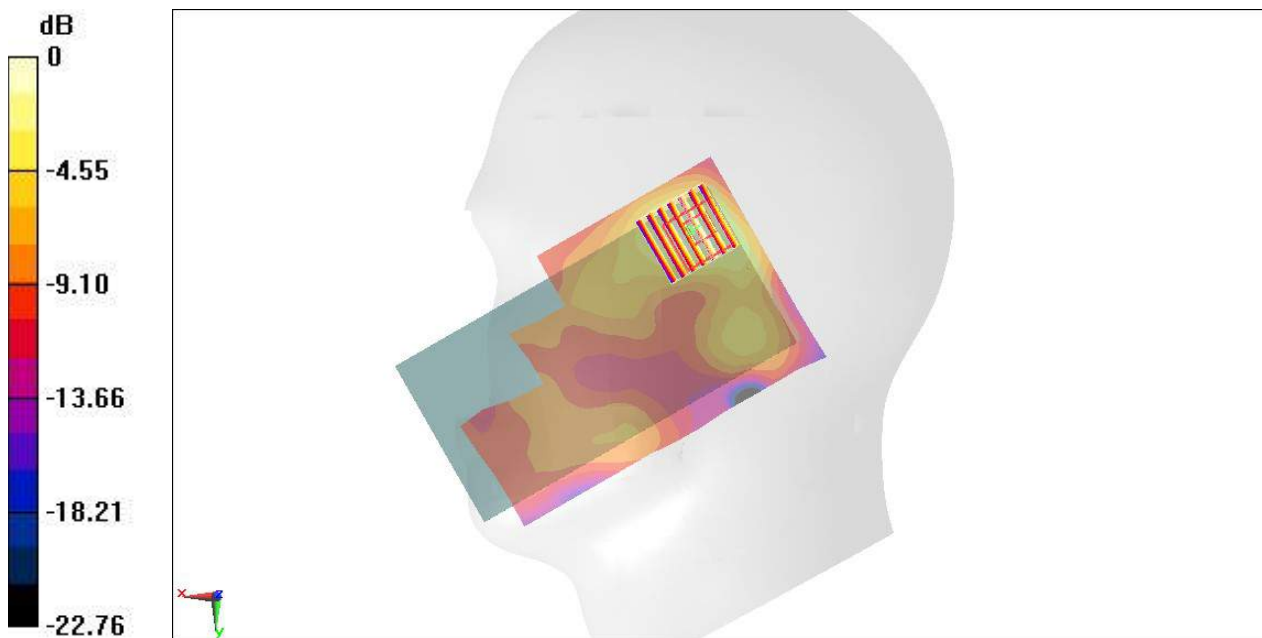

0 dB = 0.219 W/kg = -6.60 dBW/kg

#09_LTE Band 26_15M_QPSK_1_37_Right Cheek_Ch26865

Communication System: LTE; Frequency: 831.5 MHz; Duty Cycle: 1:1

Medium: HSL_850_190806 Medium parameters used: $f = 831.5$ MHz; $\sigma = 0.883$ S/m; $\epsilon_r = 42.687$; $\rho = 1000$ kg/m³

Ambient Temperature : 23.3 °C ; Liquid Temperature : 22.3 °C

DASY5 Configuration:

- Probe: EX3DV4 - SN3642; ConvF(9.05, 9.05, 9.05) @ 831.5 MHz; Calibrated: 2019/4/29
- Sensor-Surface: 1.4mm (Mechanical Surface Detection)
- Electronics: DAE3 Sn360; Calibrated: 2018/10/29
- Phantom: Twin-SAM V5.0 (30deg probe tilt); Type: QD 000 P40 CD; Serial: 1885
- Measurement SW: DASY52, Version 52.10 (2); SEMCAD X Version 14.6.12 (7470)

Area Scan (61x101x1): Interpolated grid: dx=1.500 mm, dy=1.500 mm

Maximum value of SAR (interpolated) = 0.289 W/kg

Zoom Scan (5x6x7)/Cube 0: Measurement grid: dx=8mm, dy=8mm, dz=5mm

Reference Value = 18.89 V/m; Power Drift = -0.00 dB

Peak SAR (extrapolated) = 0.320 W/kg

SAR(1 g) = 0.246 W/kg; SAR(10 g) = 0.188 W/kg

Maximum value of SAR (measured) = 0.294 W/kg

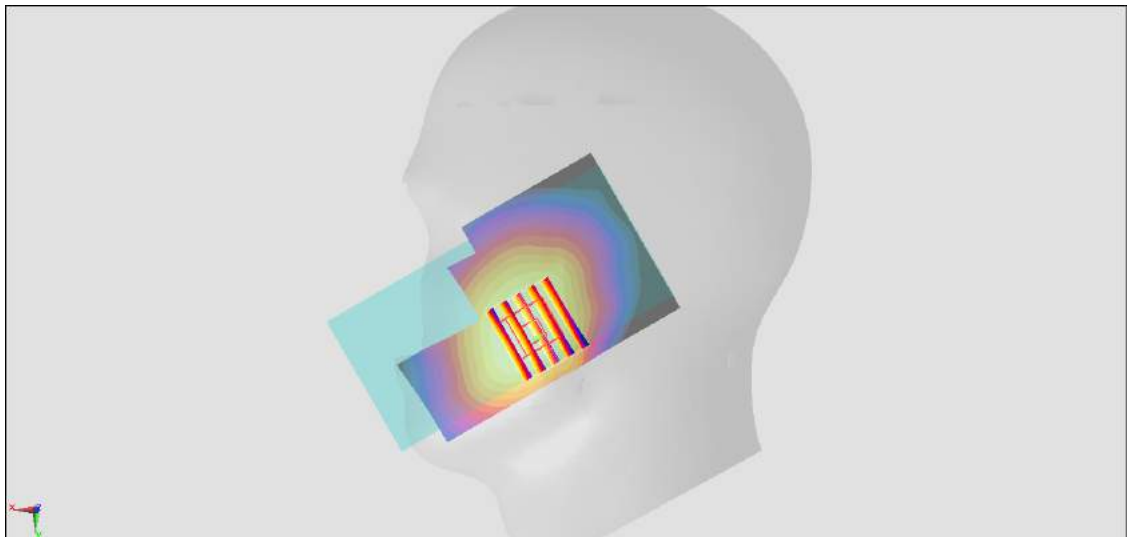
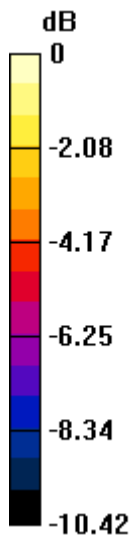

#10_LTE Band 41_20M_QPSK_1_49_Right Tilted_Ch40670

Communication System: LTE; Frequency: 2598 MHz; Duty Cycle: 1:1.59
Medium: HSL_2600_190814 Medium parameters used: $f = 2598$ MHz; $\sigma = 1.918$ S/m; $\epsilon_r = 38.405$;
 $\rho = 1000$ kg/m³
Ambient Temperature : 23.8 °C ; Liquid Temperature : 22.8 °C

DASY5 Configuration

- Probe: EX3DV4 - SN7346; ConvF(7.31, 7.31, 7.31) @ 2598 MHz; Calibrated: 2019/4/25
- Sensor-Surface: 1.4mm (Mechanical Surface Detection)
- Electronics: DAE4 Sn1326; Calibrated: 2018/9/18
- Phantom: Twin-SAM V5.0 (30deg probe tilt); Type: QD 000 P40 CD; Serial: 1885
- Measurement SW: DASY52, Version 52.10 (2); SEMCAD X Version 14.6.12 (7450)

Area Scan (81x151x1): Interpolated grid: dx=1.200 mm, dy=1.200 mm
Maximum value of SAR (interpolated) = 0.226 W/kg

Zoom Scan (7x7x7)/Cube 0: Measurement grid: dx=5mm, dy=5mm, dz=5mm
Reference Value = 5.910 V/m; Power Drift = 0.03 dB
Peak SAR (extrapolated) = 0.493 W/kg
SAR(1 g) = 0.267 W/kg; SAR(10 g) = 0.133 W/kg
Maximum value of SAR (measured) = 0.411 W/kg

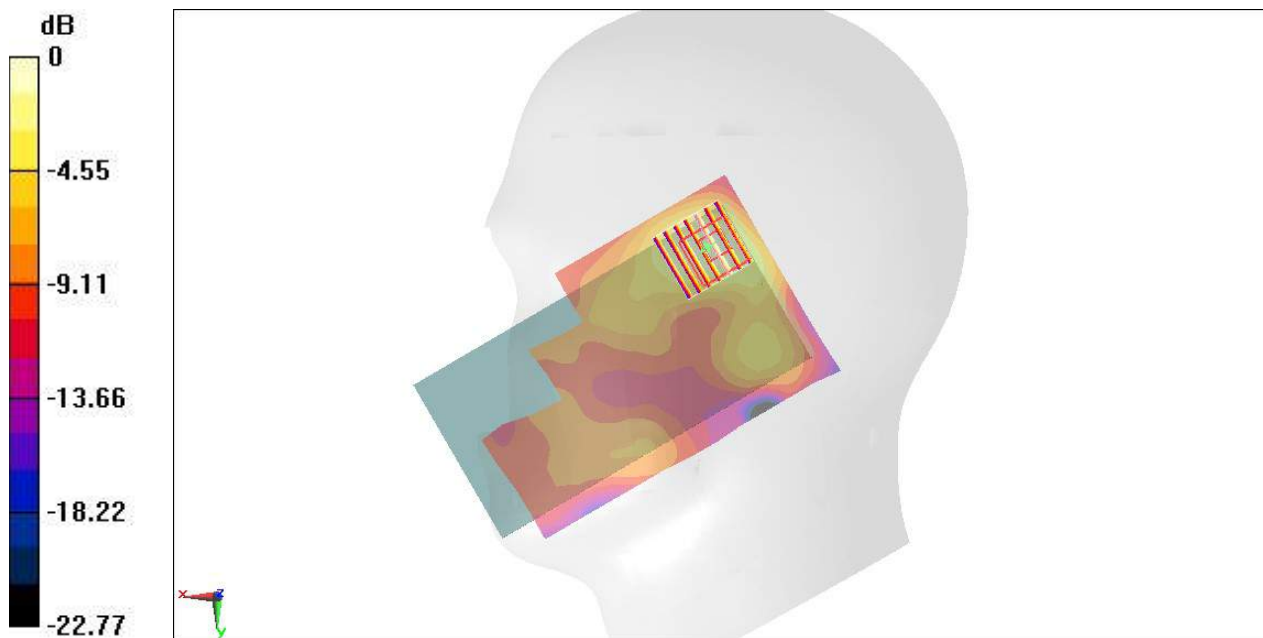

0 dB = 0.226 W/kg = -6.46 dBW/kg

#11_WLAN2.4GHz_802.11b 1Mbps_Left Cheek_Ch6

Communication System: 802.11b; Frequency: 2437 MHz; Duty Cycle: 1:1
Medium: HSL_2450_190815 Medium parameters used: $f = 2437$ MHz; $\sigma = 1.811$ S/m; $\epsilon_r = 38.988$;
 $\rho = 1000$ kg/m³
Ambient Temperature : 23.8 °C ; Liquid Temperature : 22.8 °C

DASY5 Configuration

- Probe: EX3DV4 - SN7346; ConvF(7.5, 7.5, 7.5) @ 2437 MHz; Calibrated: 2019/4/25
- Sensor-Surface: 1.4mm (Mechanical Surface Detection)
- Electronics: DAE4 Sn1326; Calibrated: 2018/9/18
- Phantom: Twin-SAM V5.0 (30deg probe tilt); Type: QD 000 P40 CD; Serial: 1885
- Measurement SW: DASY52, Version 52.10 (2); SEMCAD X Version 14.6.12 (7450)

Area Scan (81x61x1): Interpolated grid: dx=1.200 mm, dy=1.200 mm
Maximum value of SAR (interpolated) = 1.22 W/kg

Zoom Scan (7x7x7)/Cube 0: Measurement grid: dx=5mm, dy=5mm, dz=5mm
Reference Value = 19.93 V/m; Power Drift = 0.06 dB
Peak SAR (extrapolated) = 1.39 W/kg
SAR(1 g) = 0.754 W/kg; SAR(10 g) = 0.366 W/kg
Maximum value of SAR (measured) = 1.10 W/kg

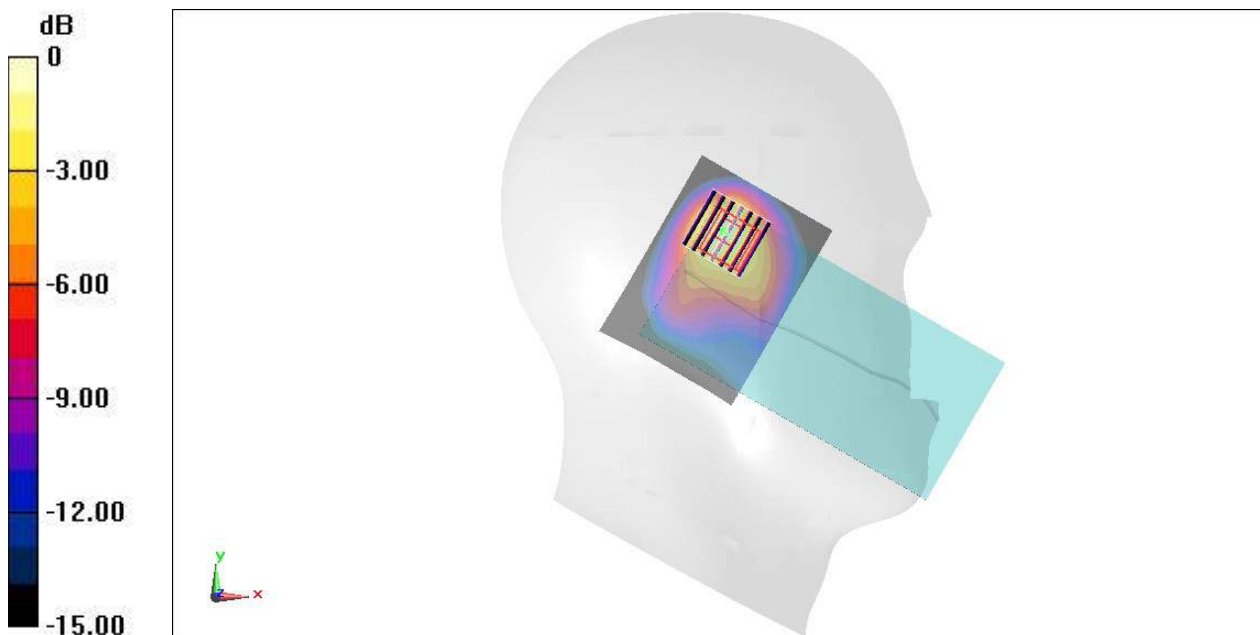

0 dB = 1.10 W/kg = 0.41 dBW/kg

#12_WLAN5GHz_802.11a 6Mbps_Right Tilted_Ch64

Communication System: 802.11a; Frequency: 5320 MHz; Duty Cycle: 1:1.018

Medium: HSL_5G_190816 Medium parameters used: $f = 5320$ MHz; $\sigma = 4.763$ S/m; $\epsilon_r = 37.079$; $\rho = 1000$ kg/m³

Ambient Temperature : 23.3 °C ; Liquid Temperature : 22.3 °C

DASY5 Configuration:

- Probe: EX3DV4 - SN3642; ConvF(4.54, 4.54, 4.54) @ 5320 MHz; Calibrated: 2019/4/29
- Sensor-Surface: 1.4mm (Mechanical Surface Detection)
- Electronics: DAE3 Sn360; Calibrated: 2018/10/29
- Phantom: SAM_Right; Type: SAM; Serial: TP:1446
- Measurement SW: DASY52, Version 52.10 (2); SEMCAD X Version 14.6.12 (7470)

Area Scan (81x81x1): Interpolated grid: dx=1.000 mm, dy=1.000 mm

Maximum value of SAR (interpolated) = 0.526 W/kg

Zoom Scan (9x8x7)/Cube 0: Measurement grid: dx=4mm, dy=4mm, dz=1.4mm

Reference Value = 9.216 V/m; Power Drift = -0.11 dB

Peak SAR (extrapolated) = 0.815 W/kg

SAR(1 g) = 0.136 W/kg; SAR(10 g) = 0.088 W/kg

Maximum value of SAR (measured) = 0.514 W/kg

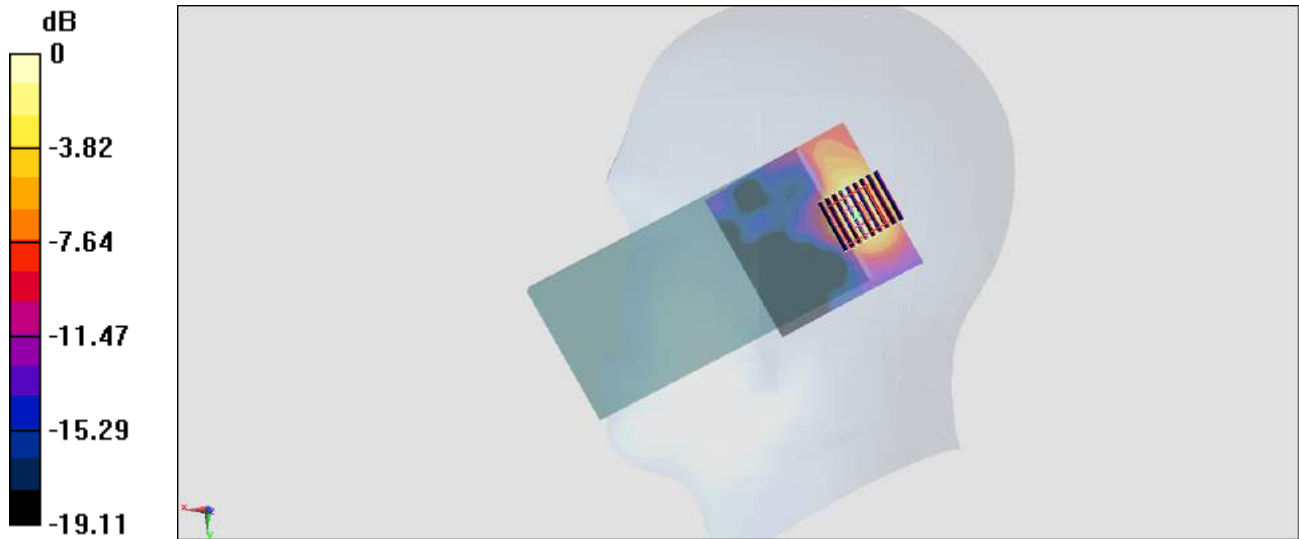

0 dB = 0.514 W/kg = -2.89 dBW/kg

#13_WLAN5GHz_802.11a 6Mbps_Right Tilted_Ch100

Communication System: 802.11a; Frequency: 5500 MHz; Duty Cycle: 1:1.018

Medium: HSL_5G_190816 Medium parameters used: $f = 5500$ MHz; $\sigma = 4.914$ S/m; $\epsilon_r = 36.718$; $\rho = 1000$ kg/m³

Ambient Temperature : 23.3 °C ; Liquid Temperature : 22.3 °C

DASY5 Configuration:

- Probe: EX3DV4 - SN3642; ConvF(4.28, 4.28, 4.28) @ 5500 MHz; Calibrated: 2019/4/29
- Sensor-Surface: 1.4mm (Mechanical Surface Detection)
- Electronics: DAE3 Sn360; Calibrated: 2018/10/29
- Phantom: SAM_Right; Type: SAM; Serial: TP:1446
- Measurement SW: DASY52, Version 52.10 (2); SEMCAD X Version 14.6.12 (7470)

Area Scan (81x81x1): Interpolated grid: dx=1.000 mm, dy=1.000 mm

Maximum value of SAR (interpolated) = 0.473 W/kg

Zoom Scan (9x8x7)/Cube 0: Measurement grid: dx=4mm, dy=4mm, dz=1.4mm

Reference Value = 9.218 V/m; Power Drift = -0.02 dB

Peak SAR (extrapolated) = 0.801 W/kg

SAR(1 g) = 0.123 W/kg; SAR(10 g) = 0.063 W/kg

Maximum value of SAR (measured) = 0.476 W/kg

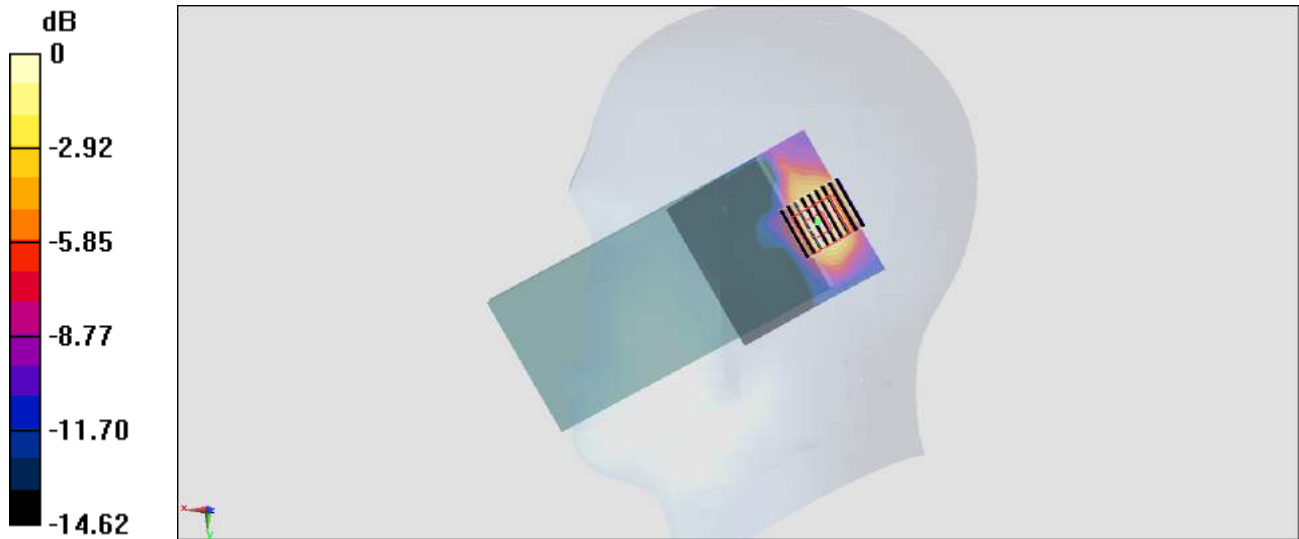

0 dB = 0.476 W/kg = -3.22 dBW/kg

#14_WLAN5GHz_802.11a 6Mbps_Right Tilted_Ch165

Communication System: 802.11a; Frequency: 5825 MHz; Duty Cycle: 1:1.018

Medium: HSL_5G_190816 Medium parameters used: $f = 5825$ MHz; $\sigma = 5.268$ S/m; $\epsilon_r = 36.255$; $\rho = 1000$ kg/m³

Ambient Temperature : 23.3 °C ; Liquid Temperature : 22.3 °C

DASY5 Configuration:

- Probe: EX3DV4 - SN3642; ConvF(4.36, 4.36, 4.36) @ 5825 MHz; Calibrated: 2019/4/29
- Sensor-Surface: 1.4mm (Mechanical Surface Detection)
- Electronics: DAE3 Sn360; Calibrated: 2018/10/29
- Phantom: SAM_Right; Type: SAM; Serial: TP:1446
- Measurement SW: DASY52, Version 52.10 (2); SEMCAD X Version 14.6.12 (7470)

Area Scan (81x81x1): Interpolated grid: dx=1.000 mm, dy=1.000 mm

Maximum value of SAR (interpolated) = 0.677 W/kg

Zoom Scan (9x8x7)/Cube 0: Measurement grid: dx=4mm, dy=4mm, dz=1.4mm

Reference Value = 11.32 V/m; Power Drift = 0.06 dB

Peak SAR (extrapolated) = 1.34 W/kg

SAR(1 g) = 0.209 W/kg; SAR(10 g) = 0.107 W/kg

Maximum value of SAR (measured) = 0.758 W/kg

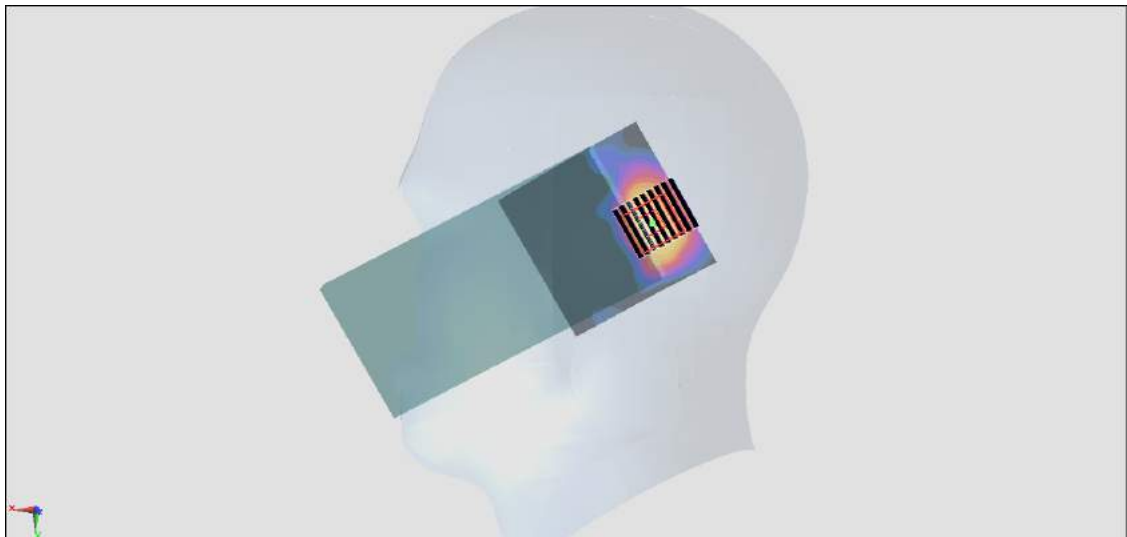
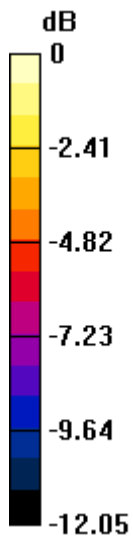

0 dB = 0.758 W/kg = -1.20 dBW/kg

#15_Bluetooth_1Mbps_Left Cheek_Ch39

Communication System: Bluetooth; Frequency: 2441 MHz; Duty Cycle: 1:1.289

Medium: HSL_2450_190815 Medium parameters used: $f = 2441$ MHz; $\sigma = 1.803$ S/m; $\epsilon_r = 38.999$; $\rho = 1000$ kg/m³

Ambient Temperature : 23.8 °C ; Liquid Temperature : 22.8 °C

DASY5 Configuration:

- Probe: EX3DV4 - SN7346; ConvF(7.5, 7.5, 7.5) @ 2441 MHz; Calibrated: 2019/4/25
- Sensor-Surface: 1.4mm (Mechanical Surface Detection)
- Electronics: DAE4 Sn1326; Calibrated: 2018/9/18
- Phantom: Twin-SAM V5.0 (30deg probe tilt); Type: QD 000 P40 CD; Serial: 1885
- Measurement SW: DASY52, Version 52.10 (2); SEMCAD X Version 14.6.12 (7470)

Area Scan (81x81x1): Interpolated grid: dx=1.200 mm, dy=1.200 mm

Maximum value of SAR (interpolated) = 0.209 W/kg

Zoom Scan (8x7x7)/Cube 0: Measurement grid: dx=5mm, dy=5mm, dz=5mm

Reference Value = 8.869 V/m; Power Drift = 0.05 dB

Peak SAR (extrapolated) = 0.229 W/kg

SAR(1 g) = 0.124 W/kg; SAR(10 g) = 0.061 W/kg

Maximum value of SAR (measured) = 0.184 W/kg

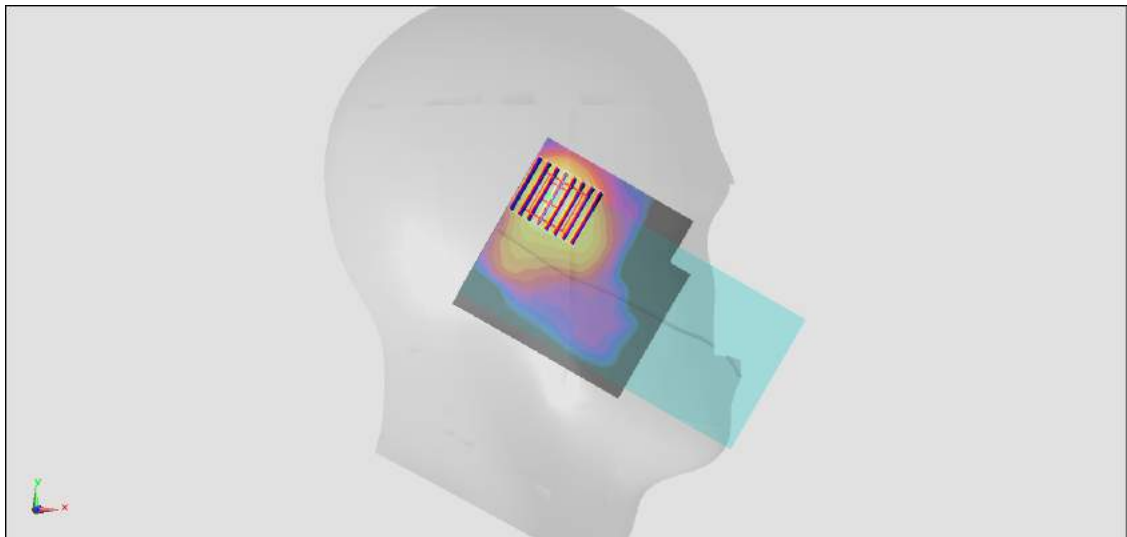
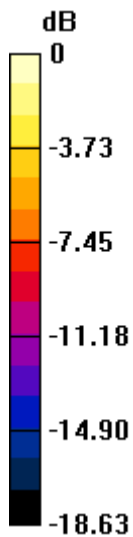

0 dB = 0.184 W/kg = -7.35 dBW/kg

#16_GSM850_GPRS (2 Tx slots)_Back_5mm_Ch251

Communication System: GSM850; Frequency: 848.8 MHz; Duty Cycle: 1:4.15
Medium: HSL_850_190816 Medium parameters used: $f = 849$ MHz; $\sigma = 0.9$ S/m; $\epsilon_r = 41.981$; $\rho = 1000$ kg/m³
Ambient Temperature : 23.3 °C ; Liquid Temperature : 22.3 °C

DASY5 Configuration

- Probe: EX3DV4 - SN7346; ConvF(9.81, 9.81, 9.81) @ 848.8 MHz; Calibrated: 2019/4/25
- Sensor-Surface: 1.4mm (Mechanical Surface Detection)
- Electronics: DAE4 Sn1326; Calibrated: 2018/9/18
- Phantom: Twin-SAM V5.0 (30deg probe tilt); Type: QD 000 P40 CD; Serial: 1885
- Measurement SW: DASY52, Version 52.10 (2); SEMCAD X Version 14.6.12 (7450)

Area Scan (61x121x1): Interpolated grid: dx=1.500 mm, dy=1.500 mm
Maximum value of SAR (interpolated) = 1.49 W/kg

zoom Scan (5x5x7)/Cube 0: Measurement grid: dx=8mm, dy=8mm, dz=5mm
Reference Value = 34.54 V/m; Power Drift = 0.10 dB
Peak SAR (extrapolated) = 2.32 W/kg
SAR(1 g) = 1.14 W/kg; SAR(10 g) = 0.634 W/kg
Maximum value of SAR (measured) = 1.84 W/kg

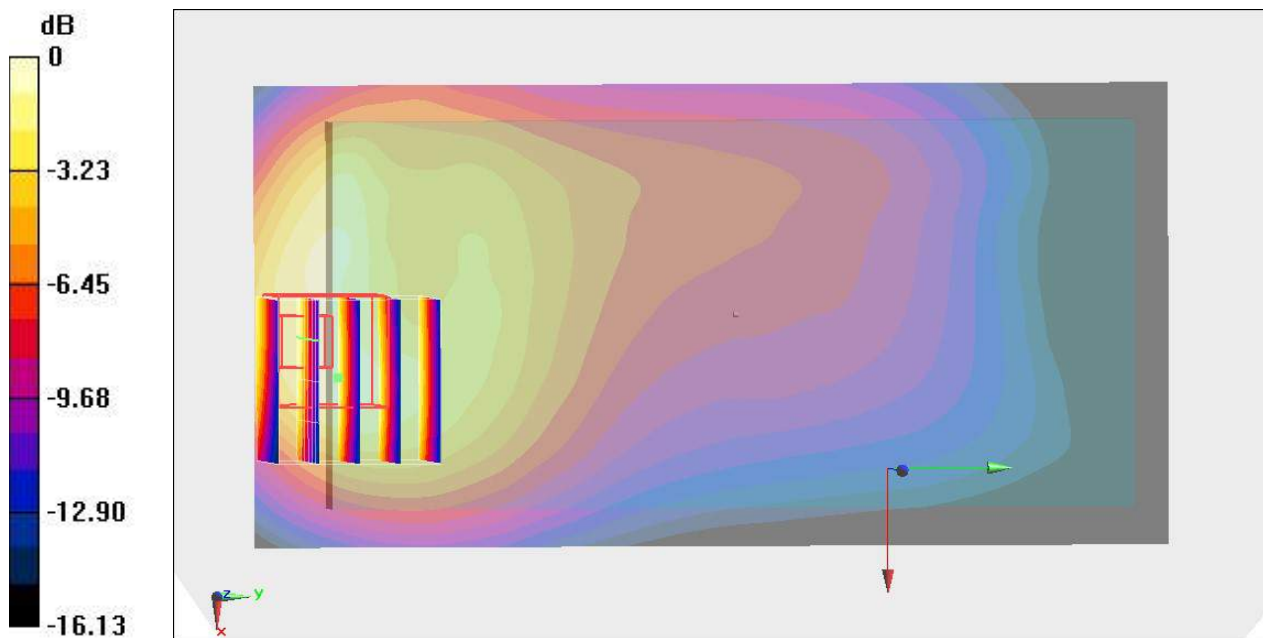

0 dB = 1.49 W/kg = 1.73 dBW/kg

#17_GSM1900_GPRS (2 Tx slots)_Bottom Side_5mm_Ch512

Communication System: PCS; Frequency: 1850.2 MHz; Duty Cycle: 1:4.15

Medium: HSL_1900_190813 Medium parameters used: $f = 1850.2$ MHz; $\sigma = 1.401$ S/m; $\epsilon_r = 38.501$; $\rho = 1000$ kg/m³

Ambient Temperature : 23.2 °C ; Liquid Temperature : 22.2 °C

DASY5 Configuration:

- Probe: EX3DV4 - SN3642; ConvF(7.91, 7.91, 7.91) @ 1850.2 MHz; Calibrated: 2019/4/29
- Sensor-Surface: 1.4mm (Mechanical Surface Detection)
- Electronics: DAE3 Sn360; Calibrated: 2018/10/29
- Phantom: SAM_Left; Type: QD000P40CD; Serial: TP:1815
- Measurement SW: DASY52, Version 52.10 (2); SEMCAD X Version 14.6.12 (7470)

Area Scan (31x61x1): Interpolated grid: dx=1.500 mm, dy=1.500 mm

Maximum value of SAR (interpolated) = 2.01 W/kg

Zoom Scan (5x5x7)/Cube 0: Measurement grid: dx=8mm, dy=8mm, dz=5mm

Reference Value = 28.38 V/m; Power Drift = 0.06 dB

Peak SAR (extrapolated) = 2.27 W/kg

SAR(1 g) = 1.16 W/kg; SAR(10 g) = 0.586 W/kg

Maximum value of SAR (measured) = 1.86 W/kg

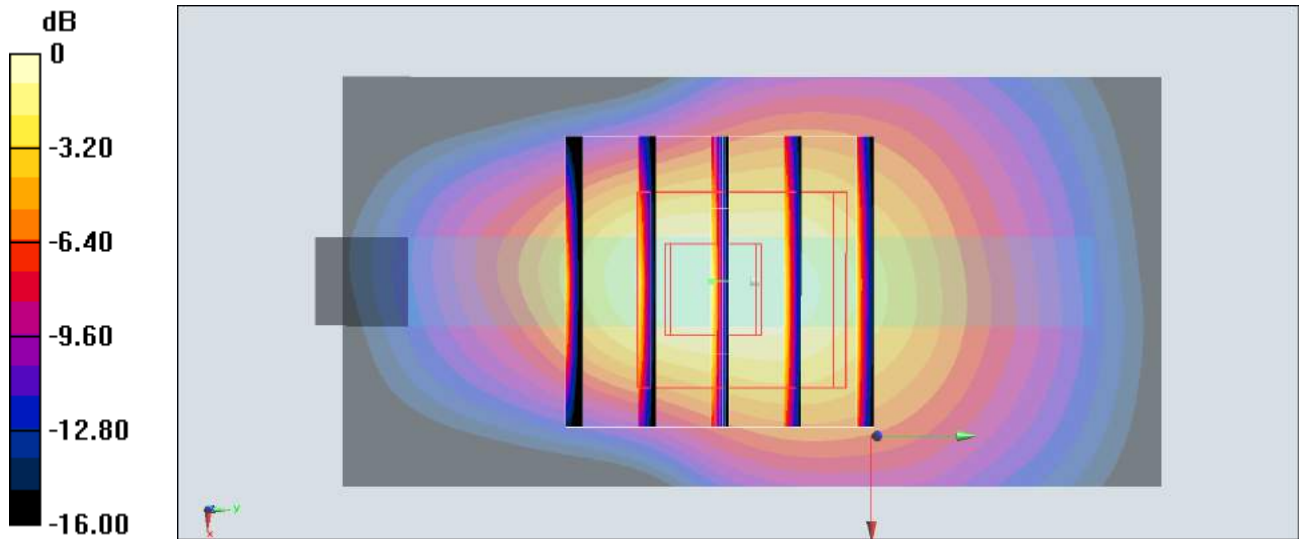

#18_WCDMA II_RMC 12.2Kbps_Bottom Side_5mm_Ch9262

Communication System: WCDMA; Frequency: 1852.4 MHz; Duty Cycle: 1:1

Medium: HSL_1900_190813 Medium parameters used: $f = 1852.4$ MHz; $\sigma = 1.403$ S/m; $\epsilon_r = 38.49$; $\rho = 1000$ kg/m³

Ambient Temperature : 23.2 °C ; Liquid Temperature : 22.2 °C

DASY5 Configuration:

- Probe: EX3DV4 - SN3642; ConvF(7.91, 7.91, 7.91) @ 1852.4 MHz; Calibrated: 2019/4/29
- Sensor-Surface: 1.4mm (Mechanical Surface Detection)
- Electronics: DAE3 Sn360; Calibrated: 2018/10/29
- Phantom: SAM_Left; Type: QD000P40CD; Serial: TP:1815
- Measurement SW: DASY52, Version 52.10 (2); SEMCAD X Version 14.6.12 (7470)

Area Scan (41x61x1): Interpolated grid: dx=1.500 mm, dy=1.500 mm

Maximum value of SAR (interpolated) = 2.03 W/kg

Zoom Scan (5x5x7)/Cube 0: Measurement grid: dx=8mm, dy=8mm, dz=5mm

Reference Value = 37.65 V/m; Power Drift = 0.03 dB

Peak SAR (extrapolated) = 2.54 W/kg

SAR(1 g) = 1.21 W/kg; SAR(10 g) = 0.580 W/kg

Maximum value of SAR (measured) = 2.04 W/kg

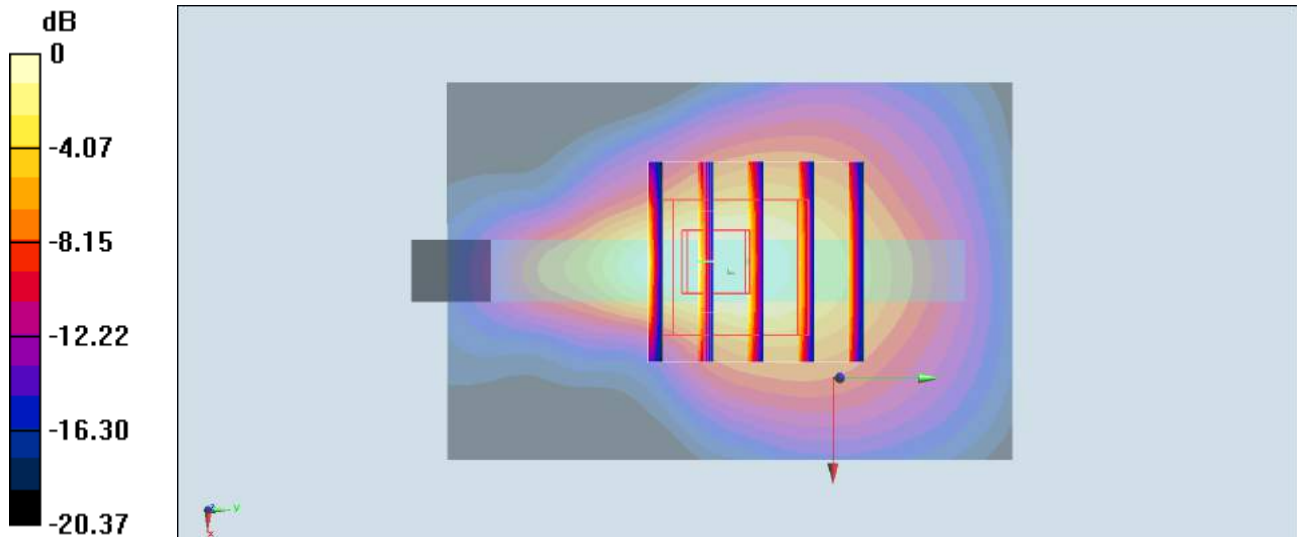

0 dB = 2.04 W/kg = 3.10 dBW/kg

#19_WCDMA IV_RMC 12.2Kbps_Bottom Side_5mm_Ch1513

Communication System: WCDMA; Frequency: 1752.6 MHz; Duty Cycle: 1:1

Medium: HSL_1750_190814 Medium parameters used: $f = 1753$ MHz; $\sigma = 1.382$ S/m; $\epsilon_r = 40.584$; $\rho = 1000$ kg/m³

Ambient Temperature : 23.2 °C ; Liquid Temperature : 22.2 °C

DASY5 Configuration:

- Probe: EX3DV4 - SN3642; ConvF(8.18, 8.18, 8.18) @ 1752.6 MHz; Calibrated: 2019/4/29
- Sensor-Surface: 1.4mm (Mechanical Surface Detection)
- Electronics: DAE3 Sn360; Calibrated: 2018/10/29
- Phantom: SAM_Left; Type: QD000P40CD; Serial: TP:1815
- Measurement SW: DASY52, Version 52.10 (2); SEMCAD X Version 14.6.12 (7470)

Area Scan (41x61x1): Interpolated grid: dx=1.500 mm, dy=1.500 mm

Maximum value of SAR (interpolated) = 1.83 W/kg

Zoom Scan (5x5x7)/Cube 0: Measurement grid: dx=8mm, dy=8mm, dz=5mm

Reference Value = 37.26 V/m; Power Drift = -0.04 dB

Peak SAR (extrapolated) = 2.25 W/kg

SAR(1 g) = 1.1 W/kg; SAR(10 g) = 0.520 W/kg

Maximum value of SAR (measured) = 1.80 W/kg

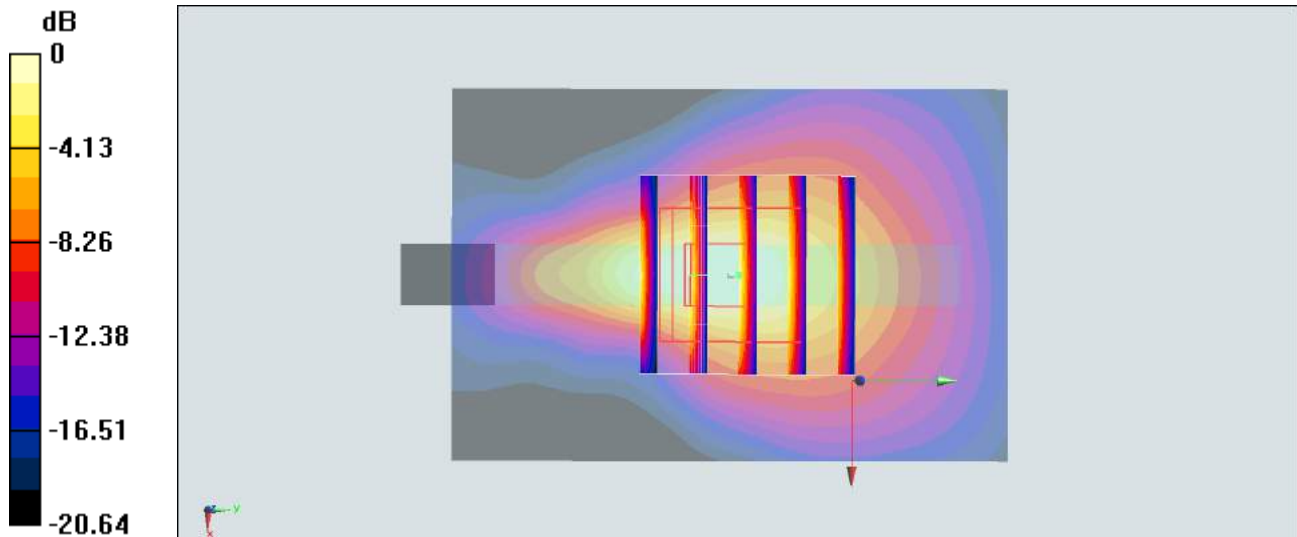

0 dB = 1.80 W/kg = 2.55 dBW/kg

#20_WCDMA V_RMC 12.2Kbps_Back_5mm_Ch4233

Communication System: WCDMA; Frequency: 846.6 MHz; Duty Cycle: 1:1
Medium: HSL_850_190808 Medium parameters used: $f = 847$ MHz; $\sigma = 0.895$ S/m; $\epsilon_r = 42.364$; $\rho = 1000$ kg/m³
Ambient Temperature : 23.5 °C ; Liquid Temperature : 22.5 °C

DASY5 Configuration

- Probe: ES3DV3 - SN3169; ConvF(6.42, 6.42, 6.42) @ 846.6 MHz; Calibrated: 2019/5/24
- Sensor-Surface: 3mm (Mechanical Surface Detection)
- Electronics: DAE4 Sn1326; Calibrated: 2018/9/18
- Phantom: Twin-SAM V5.0 (30deg probe tilt); Type: QD 000 P40 CD; Serial: 1885
- Measurement SW: DASY52, Version 52.10 (2); SEMCAD X Version 14.6.12 (7450)

Area Scan (61x61x1): Interpolated grid: dx=1.500 mm, dy=1.500 mm
Maximum value of SAR (interpolated) = 1.39 W/kg

Zoom Scan (6x6x7)/Cube 0: Measurement grid: dx=8mm, dy=8mm, dz=5mm
Reference Value = 33.68 V/m; Power Drift = -0.15 dB
Peak SAR (extrapolated) = 2.08 W/kg
SAR(1 g) = 1.15 W/kg; SAR(10 g) = 0.647 W/kg
Maximum value of SAR (measured) = 1.44 W/kg

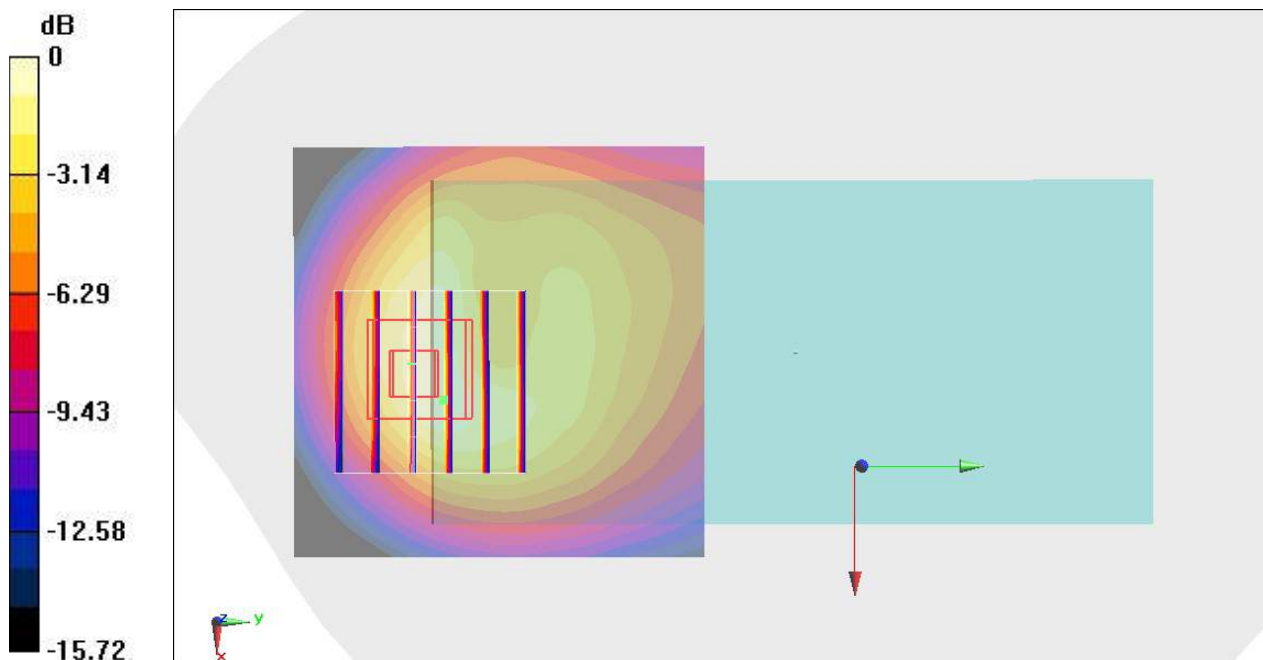

0 dB = 1.44 W/kg = 1.58 dBW/kg

#21_LTE Band 2_20M_QPSK_1_0_Bottom Side_5mm_Ch18700

Communication System: LTE; Frequency: 1860 MHz; Duty Cycle: 1:1

Medium: HSL_1900_190812 Medium parameters used: $f = 1860$ MHz; $\sigma = 1.376$ S/m; $\epsilon_r = 38.717$; $\rho = 1000$ kg/m³

Ambient Temperature : 23.5 °C ; Liquid Temperature : 22.5 °C

DASY5 Configuration:

- Probe: EX3DV4 - SN3642; ConvF(7.91, 7.91, 7.91) @ 1860 MHz; Calibrated: 2019/4/29
- Sensor-Surface: 1.4mm (Mechanical Surface Detection)
- Electronics: DAE3 Sn360; Calibrated: 2018/10/29
- Phantom: SAM_Left; Type: QD000P40CD; Serial: TP:1815
- Measurement SW: DASY52, Version 52.10 (2); SEMCAD X Version 14.6.12 (7470)

Area Scan (41x61x1): Interpolated grid: dx=1.500 mm, dy=1.500 mm

Maximum value of SAR (interpolated) = 2.04 W/kg

Zoom Scan (5x5x7)/Cube 0: Measurement grid: dx=8mm, dy=8mm, dz=5mm

Reference Value = 39.00 V/m; Power Drift = 0.12 dB

Peak SAR (extrapolated) = 2.46 W/kg

SAR(1 g) = 1.21 W/kg; SAR(10 g) = 0.584 W/kg

Maximum value of SAR (measured) = 1.96 W/kg

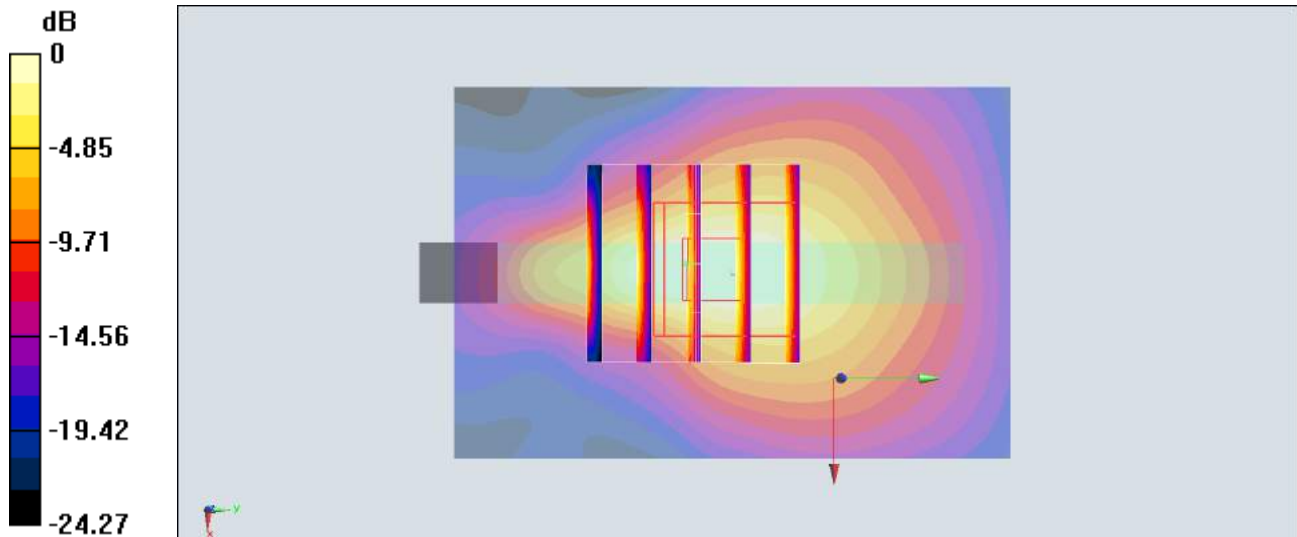

0 dB = 1.96 W/kg = 2.92 dBW/kg

#22_LTE Band 4_20M_QPSK_1_0_Bottom Side_5mm_Ch20175

Communication System: LTE; Frequency: 1732.5 MHz; Duty Cycle: 1:1

Medium: HSL_1750_190812 Medium parameters used: $f = 1733$ MHz; $\sigma = 1.371$ S/m; $\epsilon_r = 40.872$; $\rho = 1000$ kg/m³

Ambient Temperature : 23.5 °C ; Liquid Temperature : 22.5 °C

DASY5 Configuration:

- Probe: EX3DV4 - SN3642; ConvF(8.18, 8.18, 8.18) @ 1732.5 MHz; Calibrated: 2019/4/29
- Sensor-Surface: 1.4mm (Mechanical Surface Detection)
- Electronics: DAE3 Sn360; Calibrated: 2018/10/29
- Phantom: SAM_Left; Type: QD000P40CD; Serial: TP:1815
- Measurement SW: DASY52, Version 52.10 (2); SEMCAD X Version 14.6.12 (7470)

Area Scan (31x61x1): Interpolated grid: dx=1.500 mm, dy=1.500 mm

Maximum value of SAR (interpolated) = 1.53 W/kg

Zoom Scan (5x5x7)/Cube 0: Measurement grid: dx=8mm, dy=8mm, dz=5mm

Reference Value = 35.07 V/m; Power Drift = -0.03 dB

Peak SAR (extrapolated) = 1.97 W/kg

SAR(1 g) = 1.14 W/kg; SAR(10 g) = 0.474 W/kg

Maximum value of SAR (measured) = 1.65 W/kg

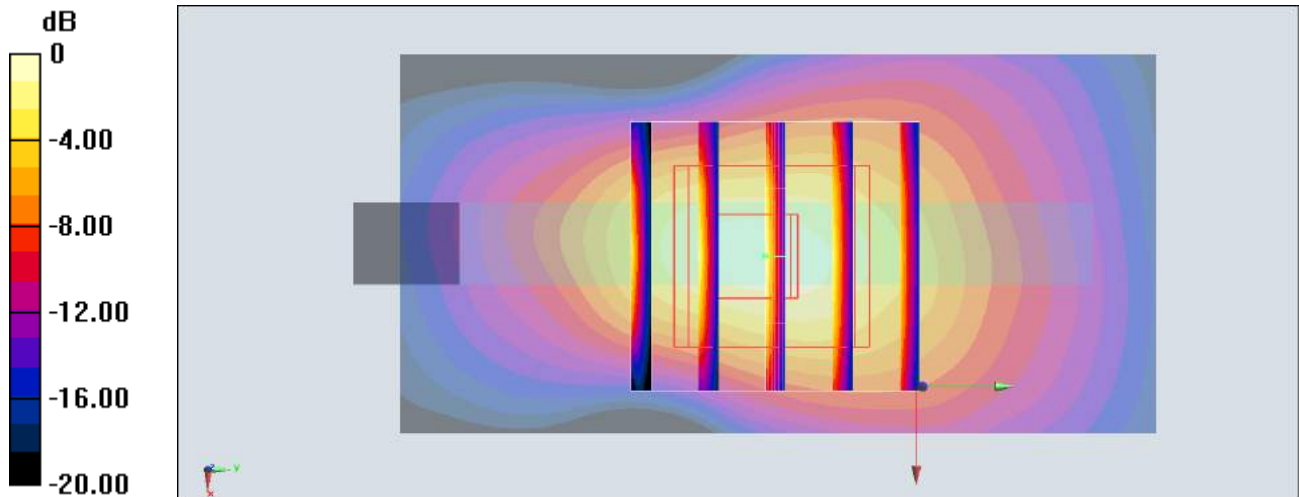

0 dB = 1.65 W/kg = 2.17 dBW/kg

#23_LTE Band 7_20M_QPSK_1_0_Back_5mm_Ch21350

Communication System: LTE; Frequency: 2560 MHz; Duty Cycle: 1:1

Medium: HSL_2600_190809 Medium parameters used: $f = 2560$ MHz; $\sigma = 1.92$ S/m; $\epsilon_r = 38.263$; $\rho = 1000$ kg/m³

Ambient Temperature : 23.4 °C ; Liquid Temperature : 22.4 °C

DASY5 Configuration:

- Probe: EX3DV4 - SN7306; ConvF(7.3, 7.3, 7.3) @ 2560 MHz; Calibrated: 2019/7/22
- Sensor-Surface: 1.4mm (Mechanical Surface Detection)
- Electronics: DAE3 Sn495; Calibrated: 2019/5/21
- Phantom: SAM_Right; Type: QD000P40CD; Serial: 1884
- Measurement SW: DASY52, Version 52.10 (2); SEMCAD X Version 14.6.12 (7470)

Area Scan (91x161x1): Interpolated grid: dx=1.200 mm, dy=1.200 mm

Maximum value of SAR (interpolated) = 3.22 W/kg

Zoom Scan (7x7x7)/Cube 0: Measurement grid: dx=5mm, dy=5mm, dz=5mm

Reference Value = 17.12 V/m; Power Drift = -0.04 dB

Peak SAR (extrapolated) = 3.19 W/kg

SAR(1 g) = 1.34 W/kg; SAR(10 g) = 0.591 W/kg

Maximum value of SAR (measured) = 2.44 W/kg

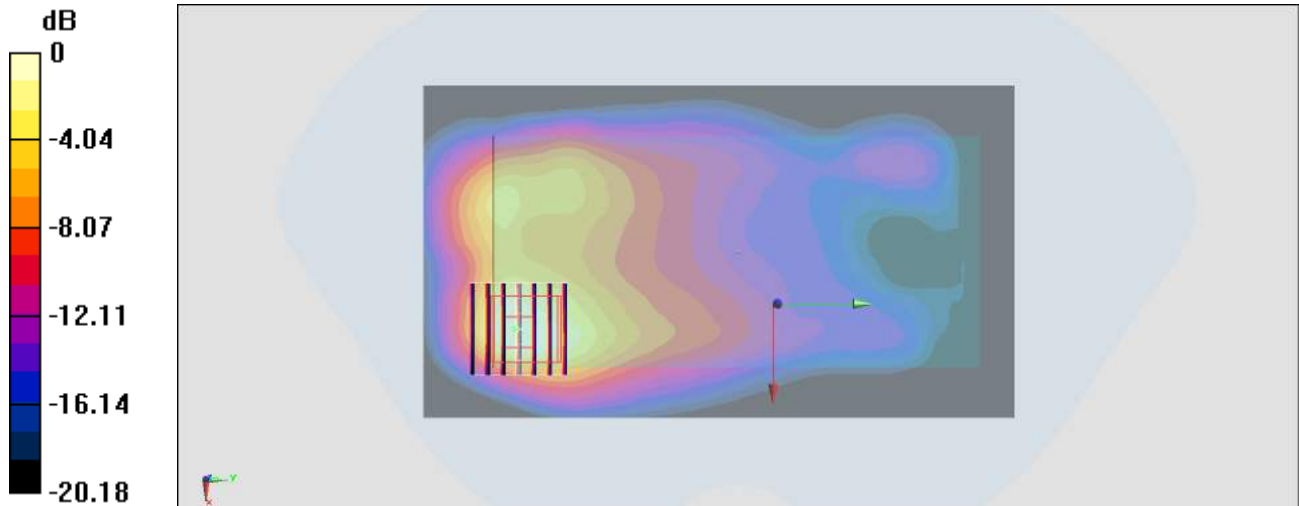

0 dB = 2.44 W/kg = 3.87 dBW/kg

#24_LTE Band 26_15M_QPSK_1_37_Back_5mm_Ch26865

Communication System: LTE; Frequency: 831.5 MHz; Duty Cycle: 1:1

Medium: HSL_850_190808 Medium parameters used: $f = 831.5$ MHz; $\sigma = 0.881$ S/m; $\epsilon_r = 42.587$; $\rho = 1000$ kg/m³

Ambient Temperature : 23.5 °C ; Liquid Temperature : 22.5 °C

DASY5 Configuration:

- Probe: ES3DV3 - SN3169; ConvF(6.42, 6.42, 6.42) @ 831.5 MHz; Calibrated: 2019/5/24
- Sensor-Surface: 3mm (Mechanical Surface Detection)
- Electronics: DAE4 Sn1326; Calibrated: 2018/9/18
- Phantom: Twin-SAM V5.0 (30deg probe tilt); Type: QD 000 P40 CD; Serial: 1885
- Measurement SW: DASY52, Version 52.10 (2); SEMCAD X Version 14.6.12 (7470)

Area Scan (61x61x1): Interpolated grid: dx=1.500 mm, dy=1.500 mm

Maximum value of SAR (interpolated) = 1.29 W/kg

Zoom Scan (6x6x7)/Cube 0: Measurement grid: dx=8mm, dy=8mm, dz=5mm

Reference Value = 31.65 V/m; Power Drift = -0.09 dB

Peak SAR (extrapolated) = 1.81 W/kg

SAR(1 g) = 0.994 W/kg; SAR(10 g) = 0.563 W/kg

Maximum value of SAR (measured) = 1.26 W/kg

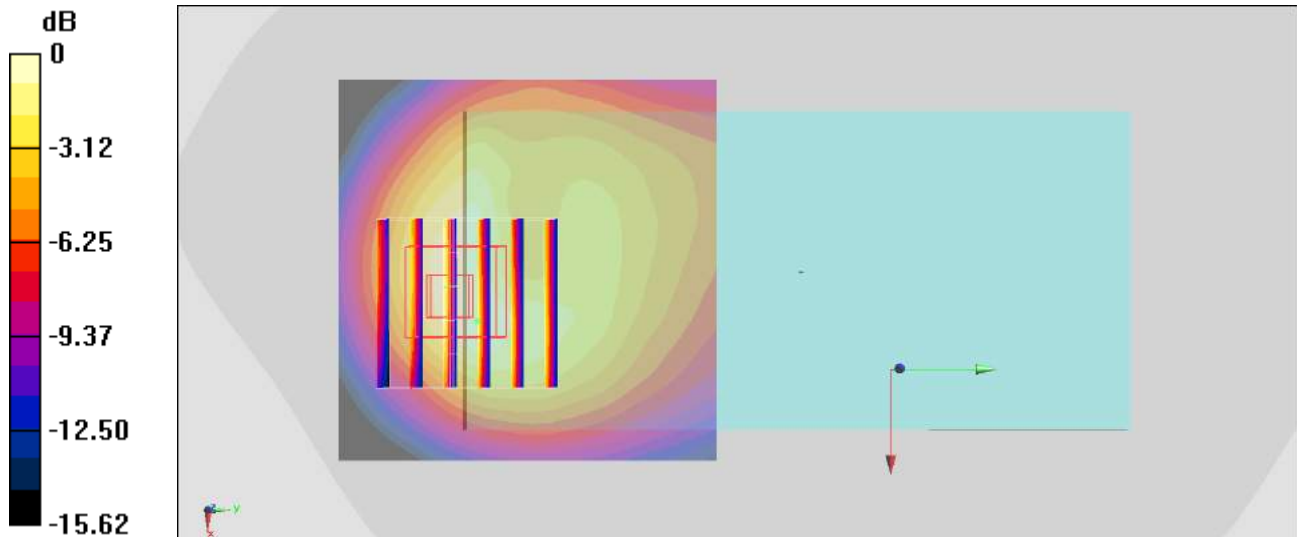

0 dB = 1.26 W/kg = 1.00 dBW/kg

#25_LTE Band 41_20M_QPSK_1_0_Back_5mm_Ch40670

Communication System: LTE; Frequency: 2598 MHz; Duty Cycle: 1:1.59
Medium: HSL_2600_190809 Medium parameters used: $f = 2598$ MHz; $\sigma = 1.964$ S/m; $\epsilon_r = 38.726$;
 $\rho = 1000$ kg/m³
Ambient Temperature : 23.5 °C ; Liquid Temperature : 22.5 °C

DASY5 Configuration

- Probe: ES3DV3 - SN3169; ConvF(4.38, 4.38, 4.38) @ 2598 MHz; Calibrated: 2019/5/24
- Sensor-Surface: 3mm (Mechanical Surface Detection)
- Electronics: DAE4 Sn1326; Calibrated: 2018/9/18
- Phantom: Twin-SAM V5.0 (30deg probe tilt); Type: QD 000 P40 CD; Serial: 1885
- Measurement SW: DASY52, Version 52.10 (2); SEMCAD X Version 14.6.12 (7450)

Area Scan (81x81x1): Interpolated grid: dx=1.200 mm, dy=1.200 mm
Maximum value of SAR (interpolated) = 1.62 W/kg

Zoom Scan (7x7x7)/Cube 0: Measurement grid: dx=5mm, dy=5mm, dz=5mm
Reference Value = 13.92 V/m; Power Drift = -0.01 dB
Peak SAR (extrapolated) = 2.84 W/kg
SAR(1 g) = 1.2 W/kg; SAR(10 g) = 0.489 W/kg
Maximum value of SAR (measured) = 1.48 W/kg

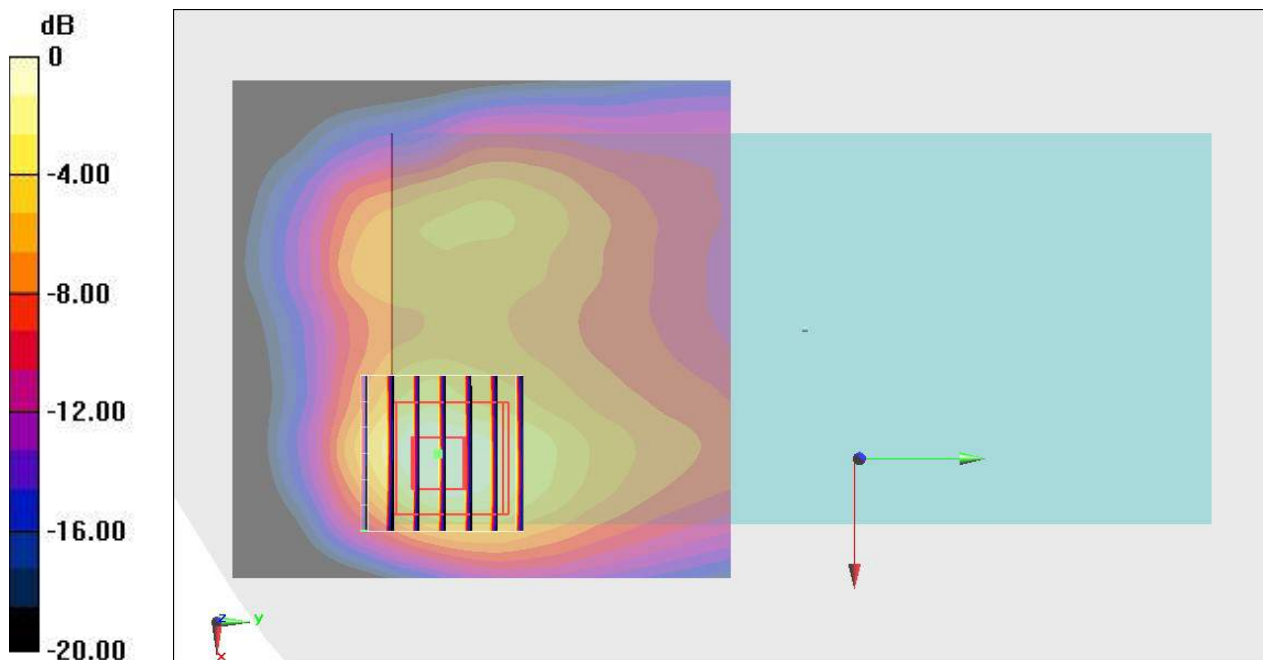

0 dB = 1.48 W/kg = 1.70 dBW/kg

#26_WLAN2.4GHz_802.11b 1Mbps_Back_5mm_Ch6

Communication System: 802.11b; Frequency: 2437 MHz; Duty Cycle: 1:1
Medium: HSL_2450_190815 Medium parameters used : $f = 2437$ MHz; $\sigma = 1.811$ S/m; $\epsilon_r = 38.988$;
 $\rho = 1000$ kg/m³
Ambient Temperature : 23.8 °C ; Liquid Temperature : 22.8 °C

DASY5 Configuration

- Probe: EX3DV4 - SN7346; ConvF(7.5, 7.5, 7.5) @ 2437 MHz; Calibrated: 2019/4/25
- Sensor-Surface: 1.4mm (Mechanical Surface Detection)
- Electronics: DAE4 Sn1326; Calibrated: 2018/9/18
- Phantom: Twin-SAM V5.0 (30deg probe tilt); Type: QD 000 P40 CD; Serial: 1885
- Measurement SW: DASY52, Version 52.10 (2); SEMCAD X Version 14.6.12 (7450)

Area Scan (71x61x1): Interpolated grid: dx=1.200 mm, dy=1.200 mm
Maximum value of SAR (interpolated) = 0.762 W/kg

Zoom Scan (7x7x7)/Cube 0: Measurement grid: dx=5mm, dy=5mm, dz=5mm
Reference Value = 13.17 V/m; Power Drift = 0.02 dB
Peak SAR (extrapolated) = 1.04 W/kg
SAR(1 g) = 0.532 W/kg; SAR(10 g) = 0.249 W/kg
Maximum value of SAR (measured) = 0.835 W/kg

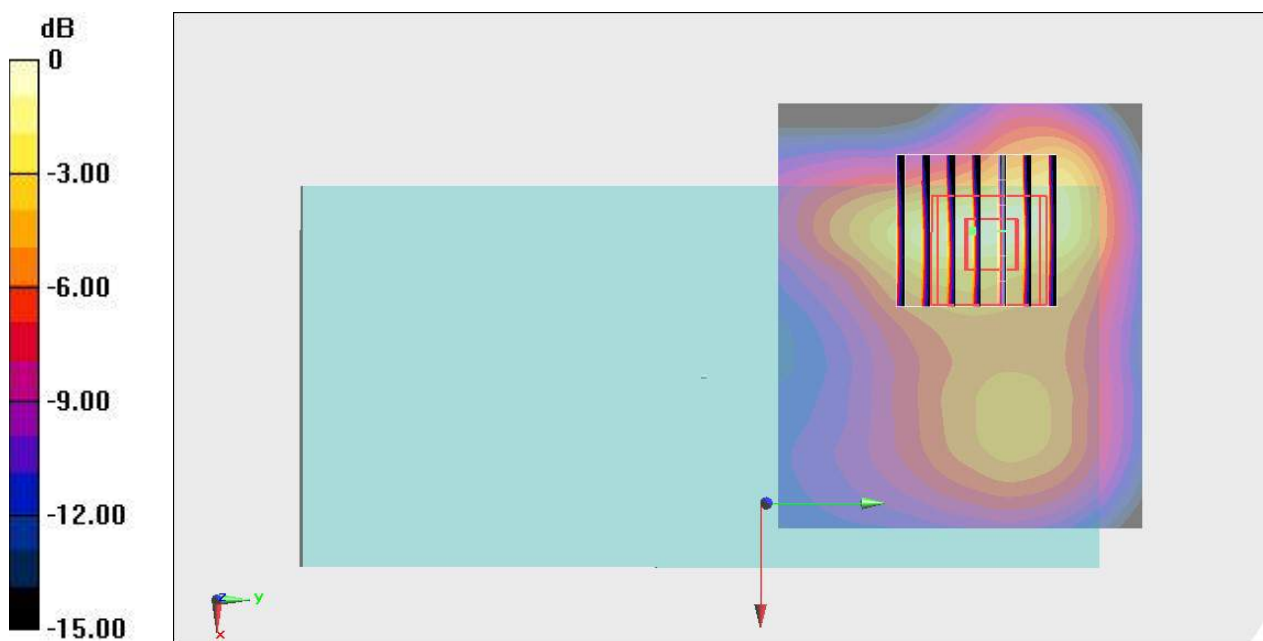

0 dB = 0.835 W/kg = -0.78 dBW/kg

#27_WLAN5GHz_802.11a 6Mbps_Back_5mm_Ch40

Communication System: 802.11a; Frequency: 5200 MHz; Duty Cycle: 1:1.018

Medium: HSL_5G_190816 Medium parameters used: $f = 5200$ MHz; $\sigma = 4.586$ S/m; $\epsilon_r = 37.06$; $\rho = 1000$ kg/m³

Ambient Temperature : 23.3 °C ; Liquid Temperature : 22.3 °C

DASY5 Configuration:

- Probe: EX3DV4 - SN3642; ConvF(4.54, 4.54, 4.54) @ 5200 MHz; Calibrated: 2019/4/29
- Sensor-Surface: 1.4mm (Mechanical Surface Detection)
- Electronics: DAE3 Sn360; Calibrated: 2018/10/29
- Phantom: SAM_Right; Type: SAM; Serial: TP:1446
- Measurement SW: DASY52, Version 52.10 (2); SEMCAD X Version 14.6.12 (7470)

Area Scan (81x81x1): Interpolated grid: dx=1.000 mm, dy=1.000 mm Maximum value of SAR (interpolated) = 1.35 W/kg

Zoom Scan (7x7x7)/Cube 0: Measurement grid: dx=4mm, dy=4mm, dz=1.4mm

Reference Value = 17.06 V/m; Power Drift = -0.02 dB

Peak SAR (extrapolated) = 2.96 W/kg

SAR(1 g) = 0.771 W/kg; SAR(10 g) = 0.231 W/kg

Maximum value of SAR (measured) = 1.78 W/kg

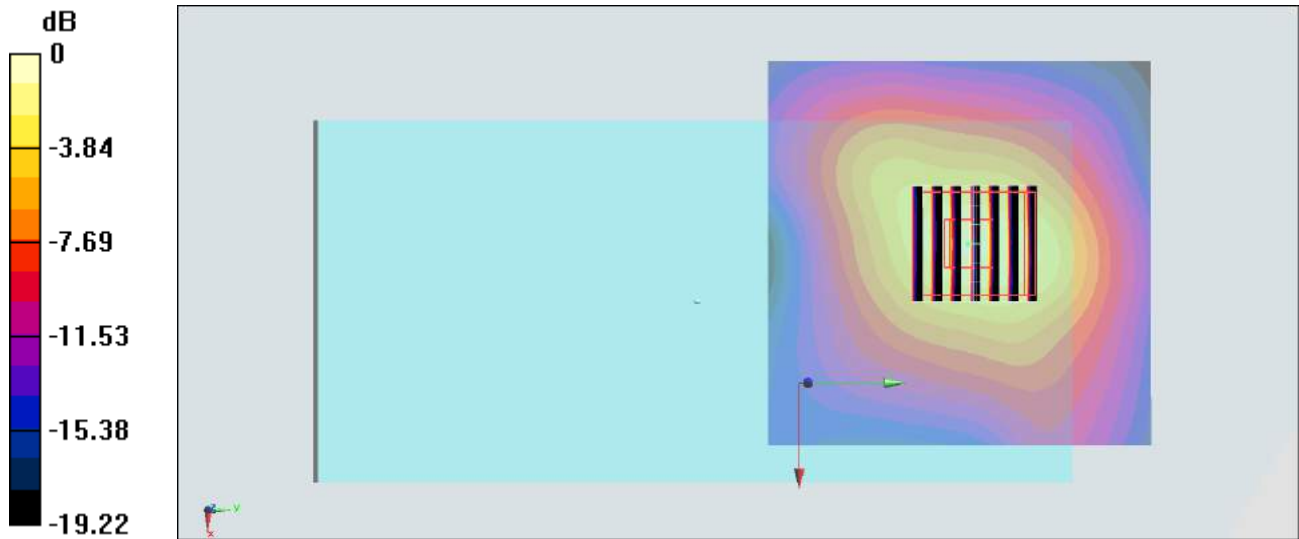

0 dB = 1.78 W/kg = 2.50 dBW/kg

#28_WLAN5GHz_802.11n-HT40 MCS0_Back_5mm_Ch159

Communication System: 802.11n; Frequency: 5795 MHz; Duty Cycle: 1:1.038

Medium: HSL_5G_190816 Medium parameters used: $f = 5795$ MHz; $\sigma = 5.315$ S/m; $\epsilon_r = 36.396$; $\rho = 1000$ kg/m³

Ambient Temperature : 23.3 °C ; Liquid Temperature : 22.3 °C

DASY5 Configuration:

- Probe: EX3DV4 - SN3642; ConvF(4.36, 4.36, 4.36) @ 5795 MHz; Calibrated: 2019/4/29
- Sensor-Surface: 1.4mm (Mechanical Surface Detection)
- Electronics: DAE3 Sn360; Calibrated: 2018/10/29
- Phantom: SAM_Right; Type: SAM; Serial: TP:1446
- Measurement SW: DASY52, Version 52.10 (2); SEMCAD X Version 14.6.12 (7470)

Area Scan (81x71x1): Interpolated grid: dx=1.000 mm, dy=1.000 mm

Maximum value of SAR (interpolated) = 2.98 W/kg

Zoom Scan (7x7x7)/Cube 0: Measurement grid: dx=4mm, dy=4mm, dz=1.4mm

Reference Value = 17.66 V/m; Power Drift = -0.11 dB

Peak SAR (extrapolated) = 4.61 W/kg

SAR(1 g) = 0.689 W/kg; SAR(10 g) = 0.228 W/kg

Maximum value of SAR (measured) = 2.64 W/kg

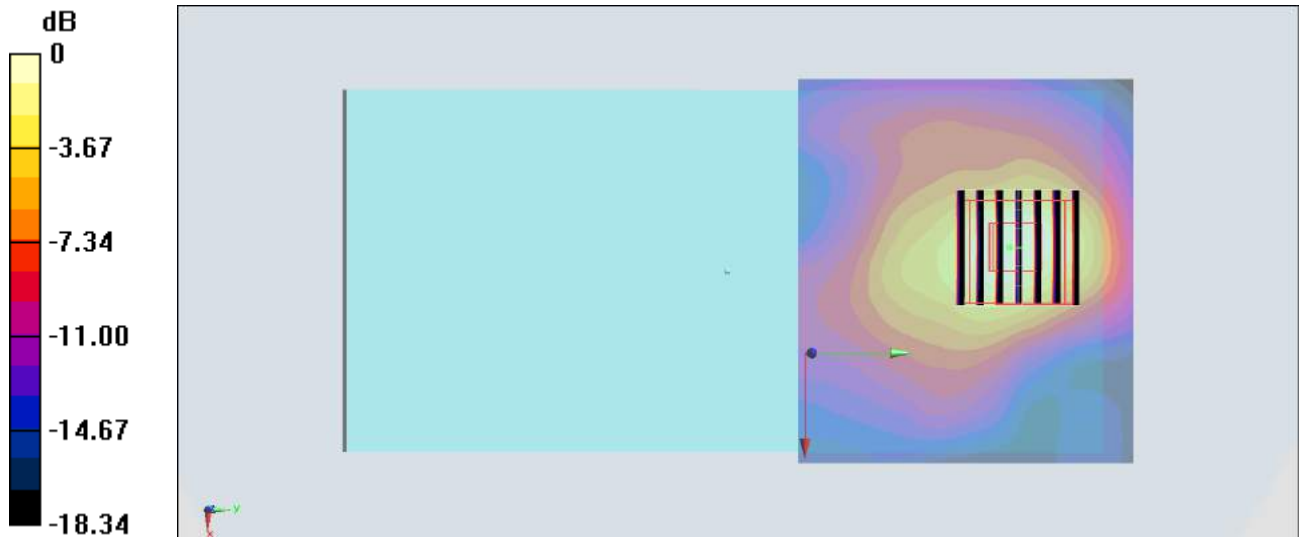

0 dB = 2.64 W/kg = 4.22 dBW/kg

#29_Bluetooth_1Mbps_Back_5mm_Ch39

Communication System: Bluetooth; Frequency: 2441 MHz; Duty Cycle: 1:1.289

Medium: HSL_2450_190815 Medium parameters used: $f = 2441$ MHz; $\sigma = 1.803$ S/m; $\epsilon_r = 38.999$; $\rho = 1000$ kg/m³

Ambient Temperature : 23.8 °C ; Liquid Temperature : 22.8 °C

DASY5 Configuration:

- Probe: EX3DV4 - SN7346; ConvF(7.5, 7.5, 7.5) @ 2441 MHz; Calibrated: 2019/4/25
- Sensor-Surface: 1.4mm (Mechanical Surface Detection)
- Electronics: DAE4 Sn1326; Calibrated: 2018/9/18
- Phantom: Twin-SAM V5.0 (30deg probe tilt); Type: QD 000 P40 CD; Serial: 1885
- Measurement SW: DASY52, Version 52.10 (2); SEMCAD X Version 14.6.12 (7470)

Area Scan (71x71x1): Interpolated grid: dx=1.200 mm, dy=1.200 mm

Maximum value of SAR (interpolated) = 0.146 W/kg

Zoom Scan (9x9x7)/Cube 0: Measurement grid: dx=5mm, dy=5mm, dz=5mm

Reference Value = 9.918 V/m; Power Drift = -0.02 dB

Peak SAR (extrapolated) = 0.245 W/kg

SAR(1 g) = 0.122 W/kg; SAR(10 g) = 0.055 W/kg

Maximum value of SAR (measured) = 0.191 W/kg

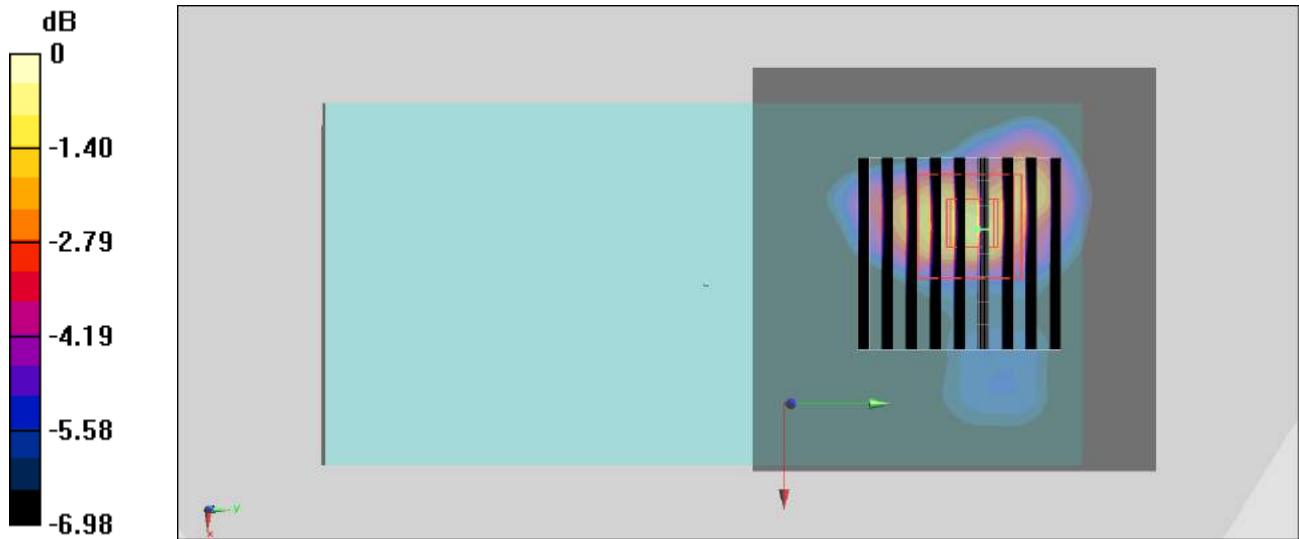

0 dB = 0.191 W/kg = -7.19 dBW/kg

#30_GSM850_GPRS (2 Tx slots)_Back_5mm_Ch251

Communication System: GSM850; Frequency: 848.8 MHz; Duty Cycle: 1:4.15
Medium: HSL_850_190816 Medium parameters used: $f = 849$ MHz; $\sigma = 0.9$ S/m; $\epsilon_r = 41.981$; $\rho = 1000$ kg/m³
Ambient Temperature : 23.3 °C ; Liquid Temperature : 22.3 °C

DASY5 Configuration

- Probe: EX3DV4 - SN7346; ConvF(9.81, 9.81, 9.81) @ 848.8 MHz; Calibrated: 2019/4/25
- Sensor-Surface: 1.4mm (Mechanical Surface Detection)
- Electronics: DAE4 Sn1326; Calibrated: 2018/9/18
- Phantom: Twin-SAM V5.0 (30deg probe tilt); Type: QD 000 P40 CD; Serial: 1885
- Measurement SW: DASY52, Version 52.10 (2); SEMCAD X Version 14.6.12 (7450)

Area Scan (61x121x1): Interpolated grid: dx=1.500 mm, dy=1.500 mm
Maximum value of SAR (interpolated) = 1.49 W/kg

zoom Scan (5x5x7)/Cube 0: Measurement grid: dx=8mm, dy=8mm, dz=5mm
Reference Value = 34.54 V/m; Power Drift = 0.10 dB
Peak SAR (extrapolated) = 2.32 W/kg
SAR(1 g) = 1.14 W/kg; SAR(10 g) = 0.634 W/kg
Maximum value of SAR (measured) = 1.84 W/kg

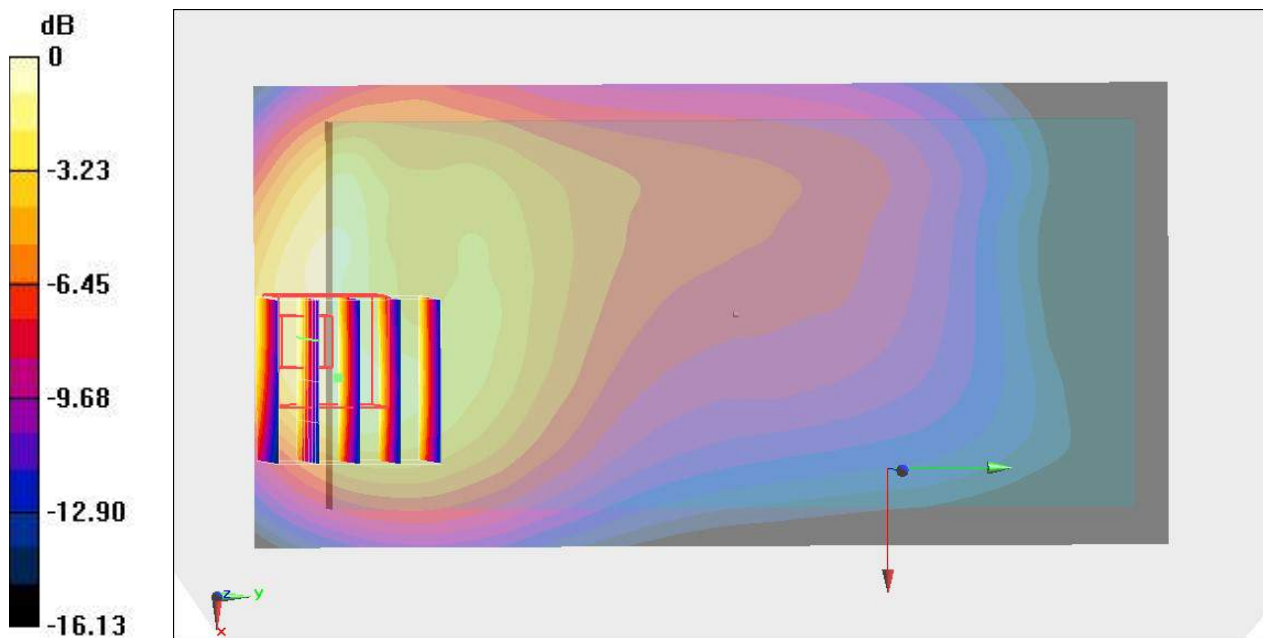

0 dB = 1.49 W/kg = 1.73 dBW/kg

#31_GSM1900_GPRS (2 Tx slots)_Back_5mm_Ch512

Communication System: PCS; Frequency: 1850.2 MHz; Duty Cycle: 1:4.15

Medium: HSL_1900_190813 Medium parameters used: $f = 1850.2$ MHz; $\sigma = 1.401$ S/m; $\epsilon_r = 38.501$; $\rho = 1000$ kg/m³

Ambient Temperature : 23.2 °C; Liquid Temperature : 22.2 °C

DASY5 Configuration:

- Probe: EX3DV4 - SN3642; ConvF(7.91, 7.91, 7.91) @ 1850.2 MHz; Calibrated: 2019/4/29
- Sensor-Surface: 1.4mm (Mechanical Surface Detection)
- Electronics: DAE3 Sn360; Calibrated: 2018/10/29
- Phantom: SAM_Left; Type: QD000P40CD; Serial: TP:1815
- Measurement SW: DASY52, Version 52.10 (2); SEMCAD X Version 14.6.12 (7470)

Area Scan (61x61x1): Interpolated grid: dx=1.500 mm, dy=1.500 mm

Maximum value of SAR (interpolated) = 2.04 W/kg

Zoom Scan (6x6x7)/Cube 0: Measurement grid: dx=8mm, dy=8mm, dz=5mm

Reference Value = 29.19 V/m; Power Drift = 0.04 dB

Peak SAR (extrapolated) = 1.96 W/kg

SAR(1 g) = 1.07 W/kg; SAR(10 g) = 0.642 W/kg

Maximum value of SAR (measured) = 1.65 W/kg

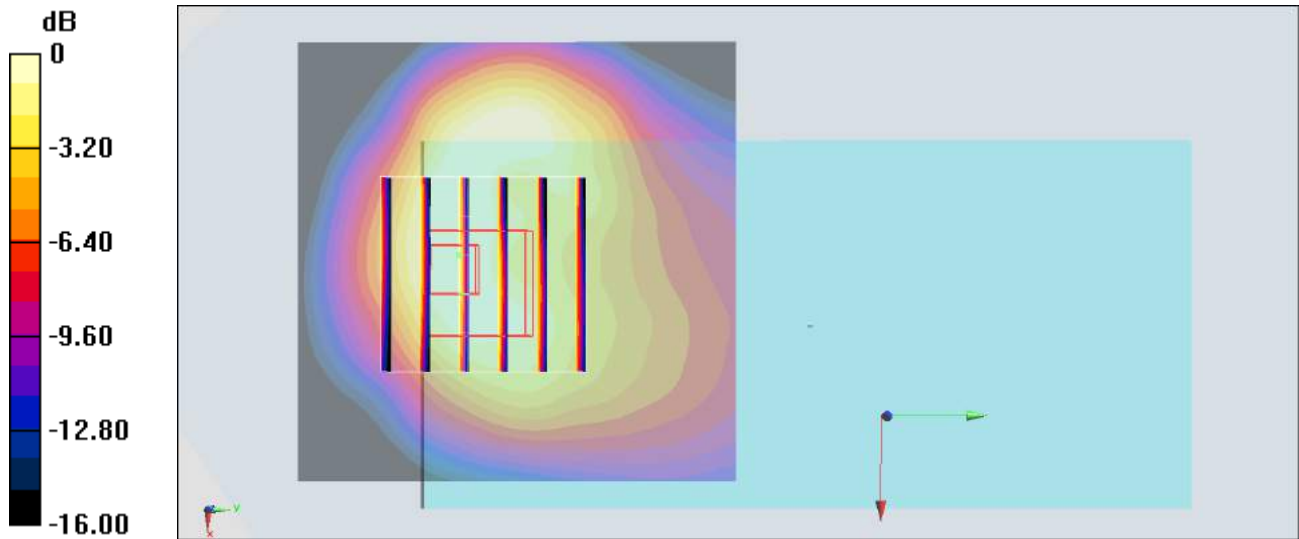

#32_WCDMA II_RMC 12.2Kbps_Back_5mm_Ch9262

Communication System: WCDMA; Frequency: 1852.4 MHz; Duty Cycle: 1:1

Medium: HSL_1900_190813 Medium parameters used: $f = 1852.4$ MHz; $\sigma = 1.403$ S/m; $\epsilon_r = 38.49$; $\rho = 1000$ kg/m³

Ambient Temperature : 23.2 °C ; Liquid Temperature : 22.2 °C

DASY5 Configuration:

- Probe: EX3DV4 - SN3642; ConvF(7.91, 7.91, 7.91) @ 1852.4 MHz; Calibrated: 2019/4/29
- Sensor-Surface: 1.4mm (Mechanical Surface Detection)
- Electronics: DAE3 Sn360; Calibrated: 2018/10/29
- Phantom: SAM_Left; Type: QD000P40CD; Serial: TP:1815
- Measurement SW: DASY52, Version 52.10 (2); SEMCAD X Version 14.6.12 (7470)

Area Scan (61x61x1): Interpolated grid: dx=1.500 mm, dy=1.500 mm

Maximum value of SAR (interpolated) = 1.89 W/kg

Zoom Scan (5x5x7)/Cube 0: Measurement grid: dx=8mm, dy=8mm, dz=5mm

Reference Value = 26.22 V/m; Power Drift = 0.03 dB

Peak SAR (extrapolated) = 2.22 W/kg

SAR(1 g) = 1.23 W/kg; SAR(10 g) = 0.698 W/kg

Maximum value of SAR (measured) = 1.52 W/kg

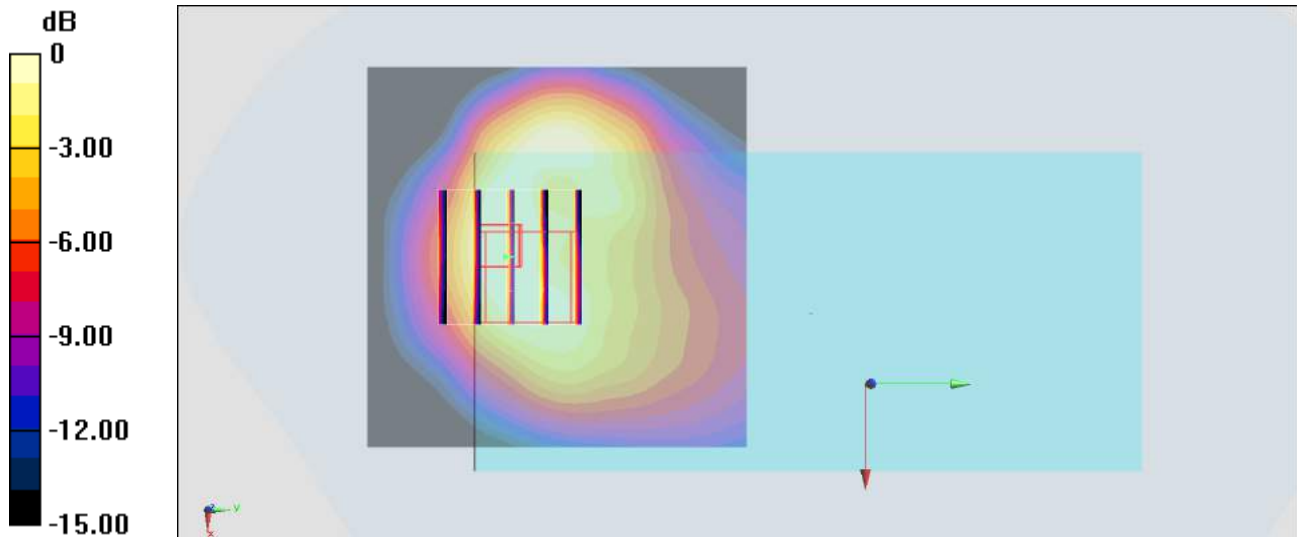

0 dB = 1.52 W/kg = 1.82 dBW/kg

#33_WCDMA_IV_RMC_12.2Kbps_Back_5mm_Ch1513

Communication System: WCDMA; Frequency: 1752.6 MHz; Duty Cycle: 1:1

Medium: HSL_1750_190814 Medium parameters used: $f = 1753$ MHz; $\sigma = 1.382$ S/m; $\epsilon_r = 40.584$; $\rho = 1000$ kg/m³

Ambient Temperature : 23.2 °C; Liquid Temperature : 22.2 °C

DASY5 Configuration:

- Probe: EX3DV4 - SN3642; ConvF(8.18, 8.18, 8.18) @ 1752.6 MHz; Calibrated: 2019/4/29
- Sensor-Surface: 1.4mm (Mechanical Surface Detection)
- Electronics: DAE3 Sn360; Calibrated: 2018/10/29
- Phantom: SAM_Left; Type: QD000P40CD; Serial: TP:1815
- Measurement SW: DASY52, Version 52.10 (2); SEMCAD X Version 14.6.12 (7470)

Area Scan (61x61x1): Interpolated grid: dx=1.500 mm, dy=1.500 mm

Maximum value of SAR (interpolated) = 1.25 W/kg

Zoom Scan (5x5x7)/Cube 0: Measurement grid: dx=8mm, dy=8mm, dz=5mm

Reference Value = 20.35 V/m; Power Drift = -0.03 dB

Peak SAR (extrapolated) = 1.84 W/kg

SAR(1 g) = 1.06 W/kg; SAR(10 g) = 0.578 W/kg

Maximum value of SAR (measured) = 1.32 W/kg

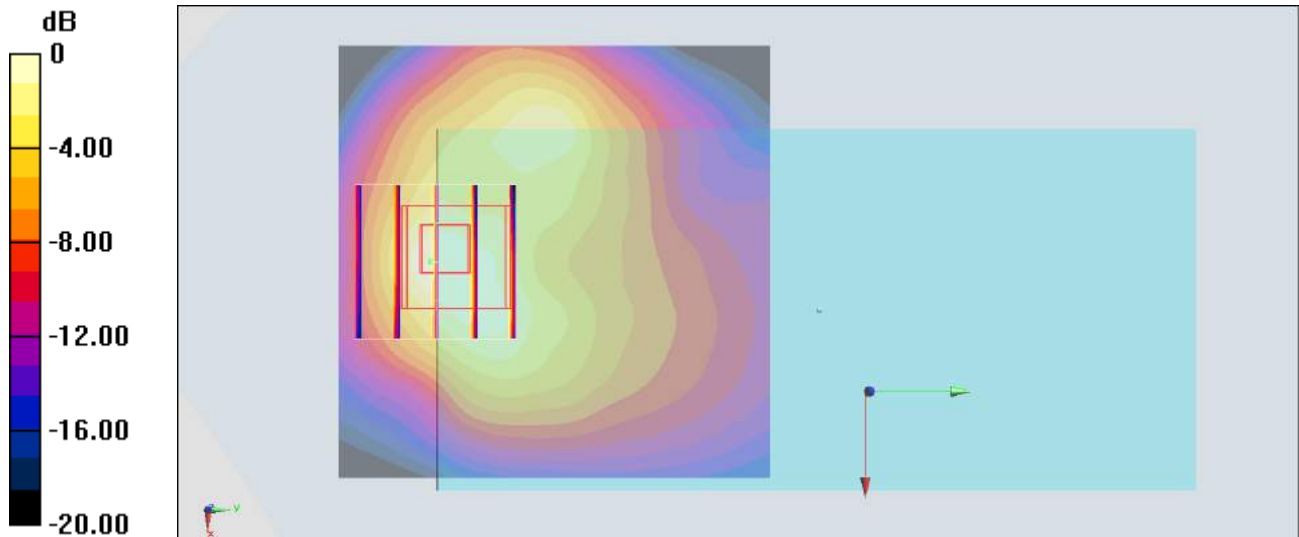

0 dB = 1.32 W/kg = 1.21 dBW/kg

#34_WCDMA V_RMC 12.2Kbps_Back_5mm_Ch4233

Communication System: WCDMA; Frequency: 846.6 MHz; Duty Cycle: 1:1
Medium: HSL_850_190808 Medium parameters used: $f = 847$ MHz; $\sigma = 0.895$ S/m; $\epsilon_r = 42.364$; $\rho = 1000$ kg/m³
Ambient Temperature : 23.5 °C ; Liquid Temperature : 22.5 °C

DASY5 Configuration

- Probe: ES3DV3 - SN3169; ConvF(6.42, 6.42, 6.42) @ 846.6 MHz; Calibrated: 2019/5/24
- Sensor-Surface: 3mm (Mechanical Surface Detection)
- Electronics: DAE4 Sn1326; Calibrated: 2018/9/18
- Phantom: Twin-SAM V5.0 (30deg probe tilt); Type: QD 000 P40 CD; Serial: 1885
- Measurement SW: DASY52, Version 52.10 (2); SEMCAD X Version 14.6.12 (7450)

Area Scan (61x61x1): Interpolated grid: dx=1.500 mm, dy=1.500 mm
Maximum value of SAR (interpolated) = 1.39 W/kg

Zoom Scan (6x6x7)/Cube 0: Measurement grid: dx=8mm, dy=8mm, dz=5mm
Reference Value = 33.68 V/m; Power Drift = -0.15 dB
Peak SAR (extrapolated) = 2.08 W/kg
SAR(1 g) = 1.15 W/kg; SAR(10 g) = 0.647 W/kg
Maximum value of SAR (measured) = 1.44 W/kg

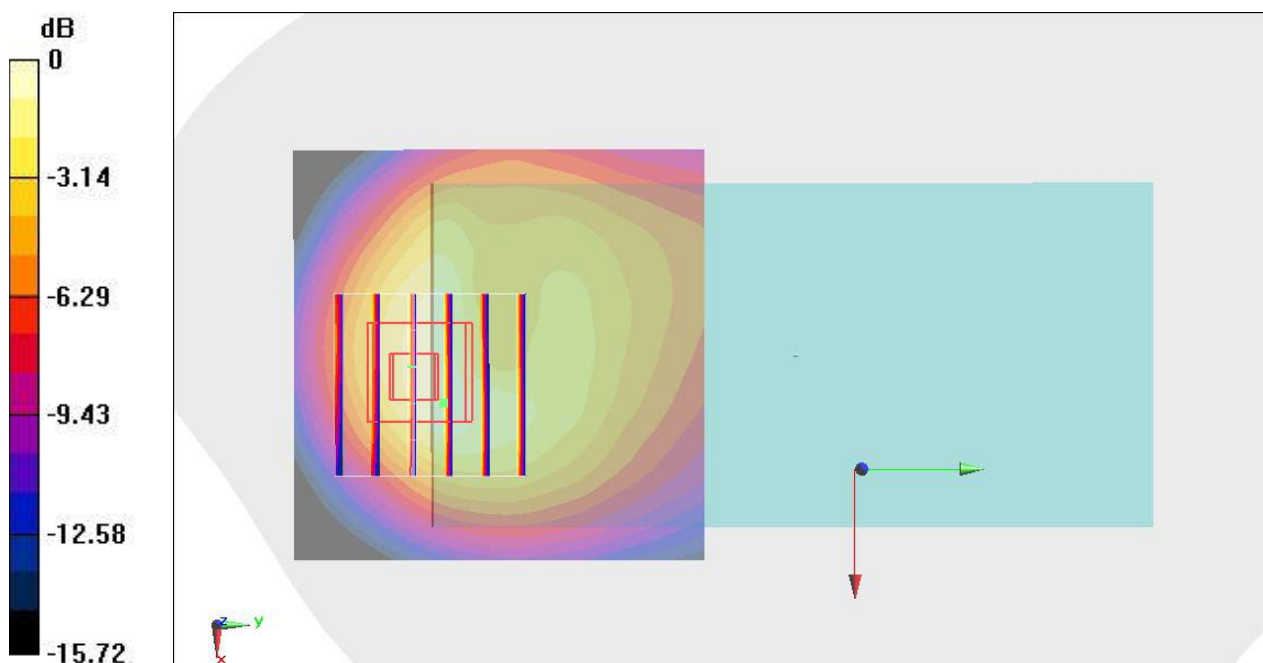

0 dB = 1.44 W/kg = 1.58 dBW/kg

#35_LTE Band 2_20M_QPSK_1_0_Back_5mm_Ch18700

Communication System: LTE; Frequency: 1860 MHz; Duty Cycle: 1:1

Medium: HSL_1900_190812 Medium parameters used: $f = 1860$ MHz; $\sigma = 1.376$ S/m; $\epsilon_r = 38.717$; $\rho = 1000$ kg/m³

Ambient Temperature : 23.5 °C ; Liquid Temperature : 22.5 °C

DASY5 Configuration:

- Probe: EX3DV4 - SN3642; ConvF(7.91, 7.91, 7.91) @ 1860 MHz; Calibrated: 2019/4/29
- Sensor-Surface: 1.4mm (Mechanical Surface Detection)
- Electronics: DAE3 Sn360; Calibrated: 2018/10/29
- Phantom: SAM_Left; Type: QD000P40CD; Serial: TP:1815
- Measurement SW: DASY52, Version 52.10 (2); SEMCAD X Version 14.6.12 (7470)

Area Scan (61x61x1): Interpolated grid: dx=1.500 mm, dy=1.500 mm

Maximum value of SAR (interpolated) = 2.28 W/kg

Zoom Scan (5x5x7)/Cube 0: Measurement grid: dx=8mm, dy=8mm, dz=5mm

Reference Value = 27.72 V/m; Power Drift = 0.11 dB

Peak SAR (extrapolated) = 2.29 W/kg

SAR(1 g) = 1.23 W/kg; SAR(10 g) = 0.711 W/kg

Maximum value of SAR (measured) = 1.87 W/kg

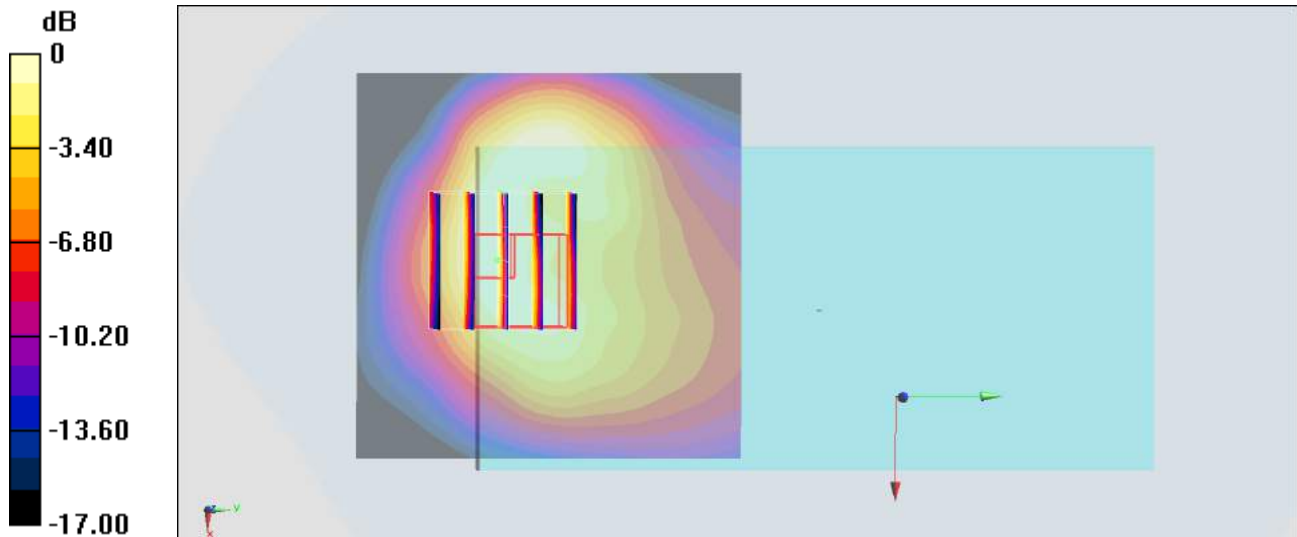

0 dB = 1.87 W/kg = 2.72 dBW/kg

#36_LTE Band 4_20M_QPSK_1_0_Back_5mm_Ch20175

Communication System: LTE; Frequency: 1732.5 MHz; Duty Cycle: 1:1

Medium: HSL_1750_190812 Medium parameters used: $f = 1733$ MHz; $\sigma = 1.371$ S/m; $\epsilon_r = 40.872$; $\rho = 1000$ kg/m³

Ambient Temperature : 23.5 °C ; Liquid Temperature : 22.5 °C

DASY5 Configuration:

- Probe: EX3DV4 - SN3642; ConvF(8.18, 8.18, 8.18) @ 1732.5 MHz; Calibrated: 2019/4/29
- Sensor-Surface: 1.4mm (Mechanical Surface Detection)
- Electronics: DAE3 Sn360; Calibrated: 2018/10/29
- Phantom: SAM_Left; Type: QD000P40CD; Serial: TP:1815
- Measurement SW: DASY52, Version 52.10 (2); SEMCAD X Version 14.6.12 (7470)

Area Scan (61x61x1): Interpolated grid: dx=1.500 mm, dy=1.500 mm

Maximum value of SAR (interpolated) = 1.80 W/kg

Zoom Scan (5x5x7)/Cube 0: Measurement grid: dx=8mm, dy=8mm, dz=5mm

Reference Value = 21.91 V/m; Power Drift = -0.03 dB

Peak SAR (extrapolated) = 1.96 W/kg

SAR(1 g) = 1.13 W/kg; SAR(10 g) = 0.576 W/kg

Maximum value of SAR (measured) = 1.68 W/kg

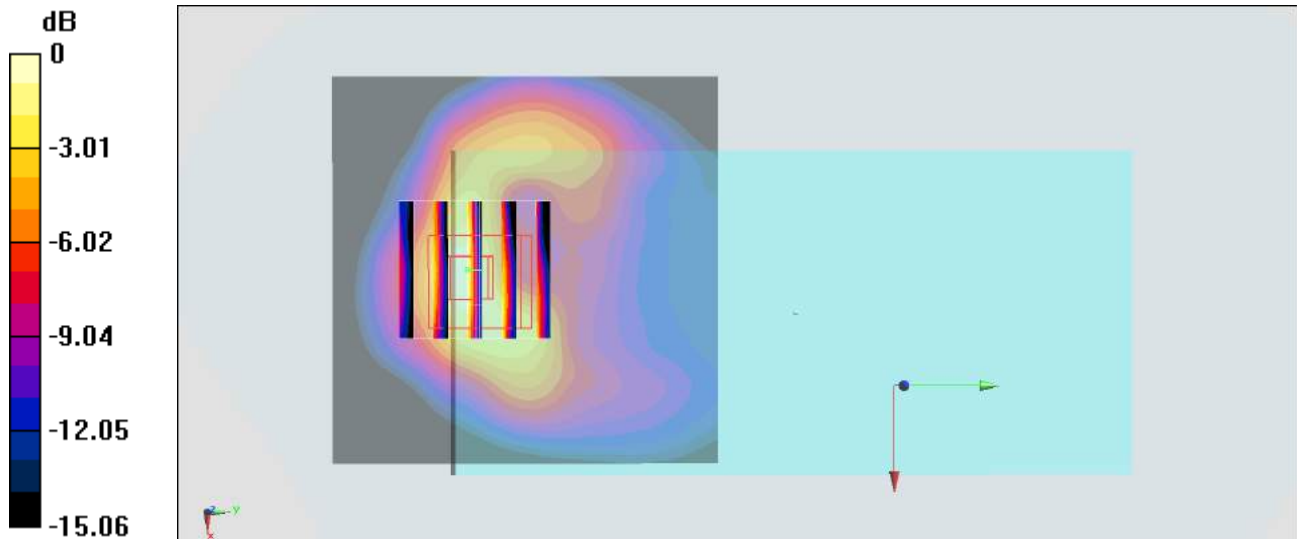

0 dB = 1.68 W/kg = 2.25 dBW/kg

#37_LTE Band 7_20M_QPSK_1_0_Back_5mm_Ch21350

Communication System: LTE; Frequency: 2560 MHz; Duty Cycle: 1:1

Medium: HSL_2600_190809 Medium parameters used: $f = 2560$ MHz; $\sigma = 1.92$ S/m; $\epsilon_r = 38.263$; $\rho = 1000$ kg/m³

Ambient Temperature : 23.4 °C ; Liquid Temperature : 22.4 °C

DASY5 Configuration:

- Probe: EX3DV4 - SN7306; ConvF(7.3, 7.3, 7.3) @ 2560 MHz; Calibrated: 2019/7/22
- Sensor-Surface: 1.4mm (Mechanical Surface Detection)
- Electronics: DAE3 Sn495; Calibrated: 2019/5/21
- Phantom: SAM_Right; Type: QD000P40CD; Serial: 1884
- Measurement SW: DASY52, Version 52.10 (2); SEMCAD X Version 14.6.12 (7470)

Area Scan (91x161x1): Interpolated grid: dx=1.200 mm, dy=1.200 mm

Maximum value of SAR (interpolated) = 3.22 W/kg

Zoom Scan (7x7x7)/Cube 0: Measurement grid: dx=5mm, dy=5mm, dz=5mm

Reference Value = 17.12 V/m; Power Drift = -0.04 dB

Peak SAR (extrapolated) = 3.19 W/kg

SAR(1 g) = 1.34 W/kg; SAR(10 g) = 0.591 W/kg

Maximum value of SAR (measured) = 2.44 W/kg

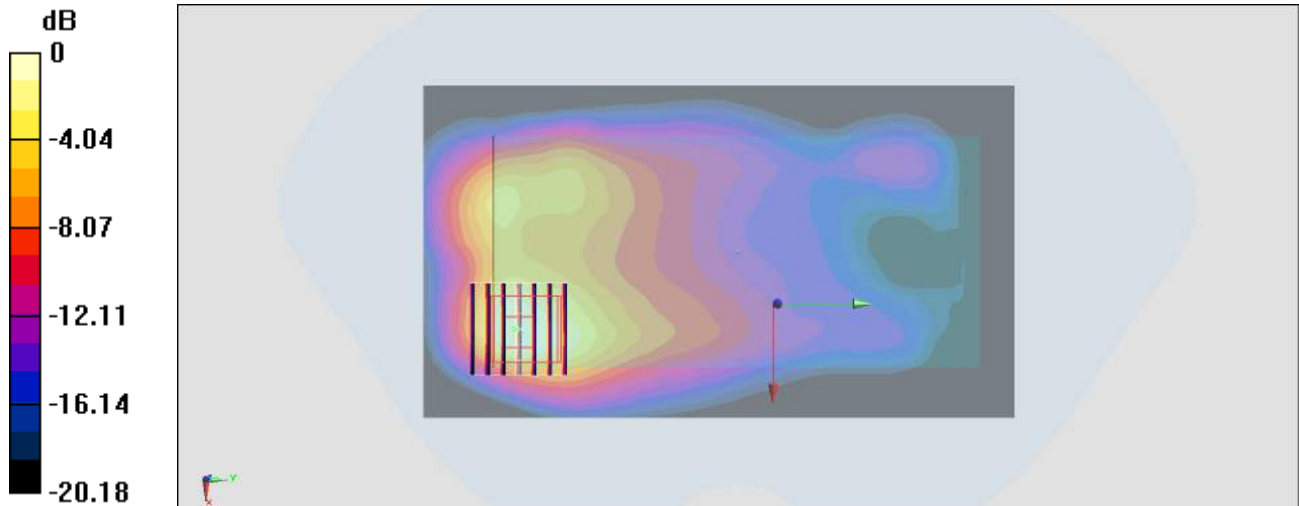

0 dB = 2.44 W/kg = 3.87 dBW/kg

#38_LTE Band 26_15M_QPSK_1_37_Back_5mm_Ch26865

Communication System: LTE; Frequency: 831.5 MHz; Duty Cycle: 1:1

Medium: HSL_850_190808 Medium parameters used: $f = 831.5$ MHz; $\sigma = 0.881$ S/m; $\epsilon_r = 42.587$; $\rho = 1000$ kg/m³

Ambient Temperature : 23.5 °C ; Liquid Temperature : 22.5 °C

DASY5 Configuration:

- Probe: ES3DV3 - SN3169; ConvF(6.42, 6.42, 6.42) @ 831.5 MHz; Calibrated: 2019/5/24
- Sensor-Surface: 3mm (Mechanical Surface Detection)
- Electronics: DAE4 Sn1326; Calibrated: 2018/9/18
- Phantom: Twin-SAM V5.0 (30deg probe tilt); Type: QD 000 P40 CD; Serial: 1885
- Measurement SW: DASY52, Version 52.10 (2); SEMCAD X Version 14.6.12 (7470)

Area Scan (61x61x1): Interpolated grid: dx=1.500 mm, dy=1.500 mm

Maximum value of SAR (interpolated) = 1.29 W/kg

Zoom Scan (6x6x7)/Cube 0: Measurement grid: dx=8mm, dy=8mm, dz=5mm

Reference Value = 31.65 V/m; Power Drift = -0.09 dB

Peak SAR (extrapolated) = 1.81 W/kg

SAR(1 g) = 0.994 W/kg; SAR(10 g) = 0.563 W/kg

Maximum value of SAR (measured) = 1.26 W/kg

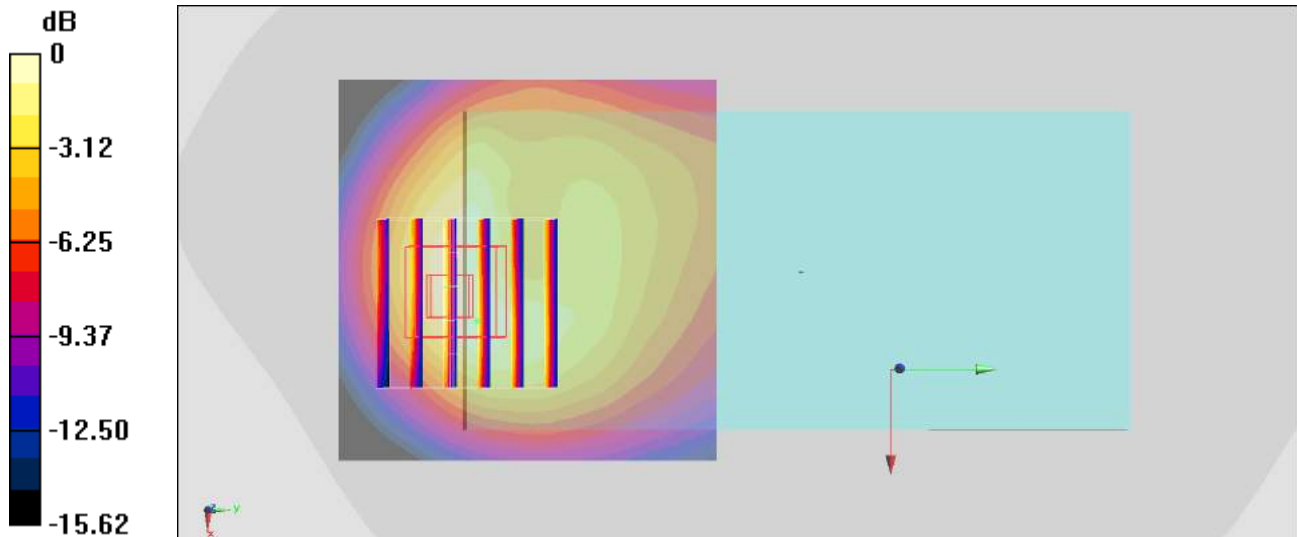

0 dB = 1.26 W/kg = 1.00 dBW/kg

#39_LTE Band 41_20M_QPSK_1_0_Back_5mm_Ch40670

Communication System: LTE; Frequency: 2598 MHz; Duty Cycle: 1:1.59
Medium: HSL_2600_190809 Medium parameters used: $f = 2598$ MHz; $\sigma = 1.964$ S/m; $\epsilon_r = 38.726$;
 $\rho = 1000$ kg/m³
Ambient Temperature : 23.5 °C ; Liquid Temperature : 22.5 °C

DASY5 Configuration

- Probe: ES3DV3 - SN3169; ConvF(4.38, 4.38, 4.38) @ 2598 MHz; Calibrated: 2019/5/24
- Sensor-Surface: 3mm (Mechanical Surface Detection)
- Electronics: DAE4 Sn1326; Calibrated: 2018/9/18
- Phantom: Twin-SAM V5.0 (30deg probe tilt); Type: QD 000 P40 CD; Serial: 1885
- Measurement SW: DASY52, Version 52.10 (2); SEMCAD X Version 14.6.12 (7450)

Area Scan (81x81x1): Interpolated grid: dx=1.200 mm, dy=1.200 mm
Maximum value of SAR (interpolated) = 1.62 W/kg

Zoom Scan (7x7x7)/Cube 0: Measurement grid: dx=5mm, dy=5mm, dz=5mm
Reference Value = 13.92 V/m; Power Drift = -0.01 dB
Peak SAR (extrapolated) = 2.84 W/kg
SAR(1 g) = 1.2 W/kg; SAR(10 g) = 0.489 W/kg
Maximum value of SAR (measured) = 1.48 W/kg

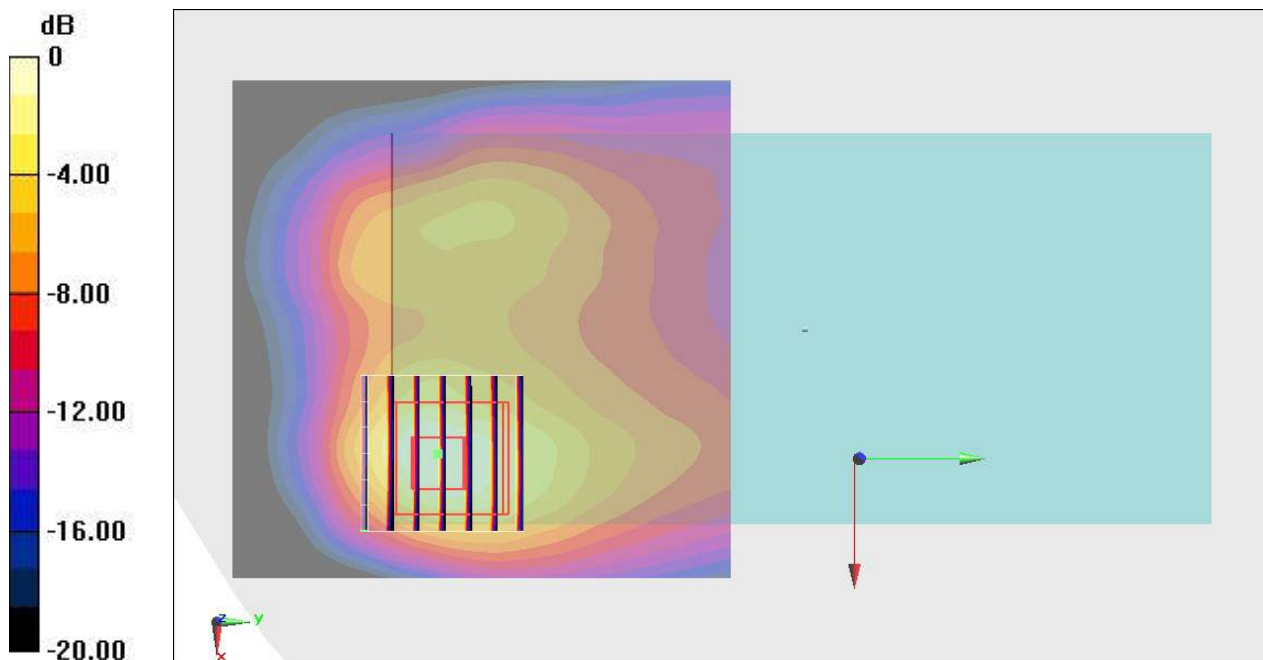

0 dB = 1.48 W/kg = 1.70 dBW/kg

#40_WLAN2.4GHz_802.11b 1Mbps_Back_5mm_Ch6

Communication System: 802.11b; Frequency: 2437 MHz; Duty Cycle: 1:1
Medium: HSL_2450_190815 Medium parameters used: $f = 2437$ MHz; $\sigma = 1.811$ S/m; $\epsilon_r = 38.988$;
 $\rho = 1000$ kg/m³
Ambient Temperature : 23.8 °C ; Liquid Temperature : 22.8 °C

DASY5 Configuration

- Probe: EX3DV4 - SN7346; ConvF(7.5, 7.5, 7.5) @ 2437 MHz; Calibrated: 2019/4/25
- Sensor-Surface: 1.4mm (Mechanical Surface Detection)
- Electronics: DAE4 Sn1326; Calibrated: 2018/9/18
- Phantom: Twin-SAM V5.0 (30deg probe tilt); Type: QD 000 P40 CD; Serial: 1885
- Measurement SW: DASY52, Version 52.10 (2); SEMCAD X Version 14.6.12 (7450)

Area Scan (71x61x1): Interpolated grid: dx=1.200 mm, dy=1.200 mm
Maximum value of SAR (interpolated) = 0.762 W/kg

Zoom Scan (7x7x7)/Cube 0: Measurement grid: dx=5mm, dy=5mm, dz=5mm
Reference Value = 13.17 V/m; Power Drift = 0.02 dB
Peak SAR (extrapolated) = 1.04 W/kg
SAR(1 g) = 0.532 W/kg; SAR(10 g) = 0.249 W/kg
Maximum value of SAR (measured) = 0.835 W/kg

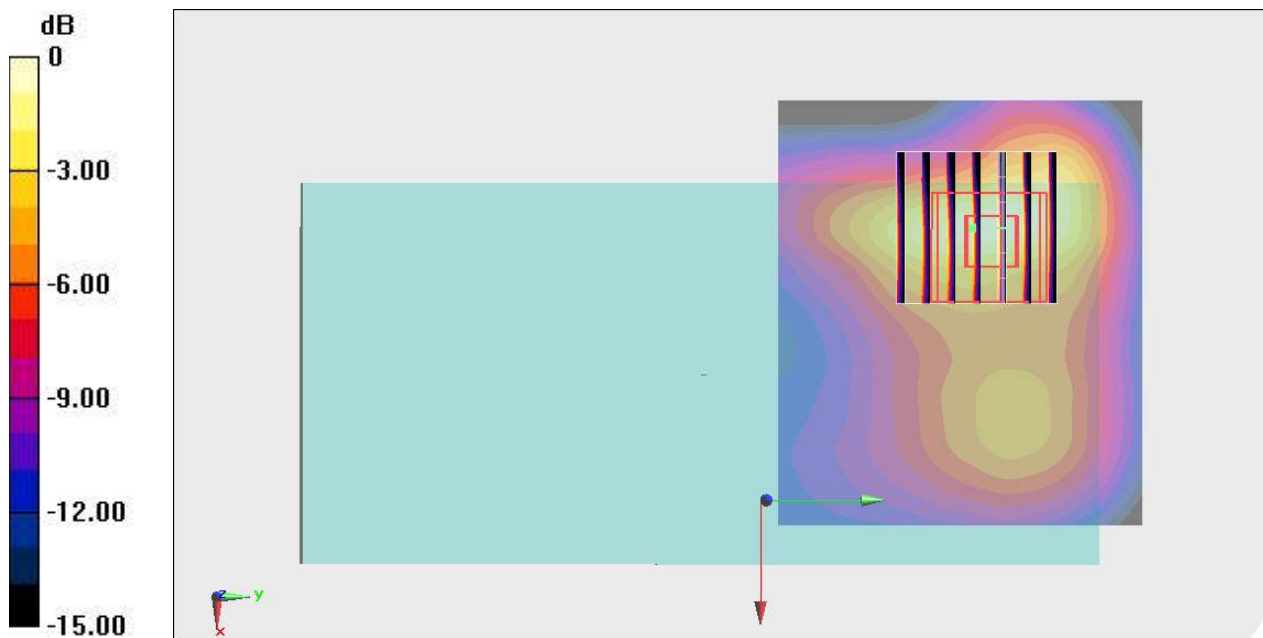

0 dB = 0.835 W/kg = -0.78 dBW/kg

#41_WLAN5GHz_802.11a_6Mbps_Back_5mm_Ch40

Communication System: 802.11a; Frequency: 5200 MHz; Duty Cycle: 1:1.018

Medium: HSL_5G_190816 Medium parameters used: $f = 5200$ MHz; $\sigma = 4.586$ S/m; $\epsilon_r = 37.06$; $\rho = 1000$ kg/m³

Ambient Temperature : 23.3 °C ; Liquid Temperature : 22.3 °C

DASY5 Configuration:

- Probe: EX3DV4 - SN3642; ConvF(4.54, 4.54, 4.54) @ 5200 MHz; Calibrated: 2019/4/29
- Sensor-Surface: 1.4mm (Mechanical Surface Detection)
- Electronics: DAE3 Sn360; Calibrated: 2018/10/29
- Phantom: SAM_Right; Type: SAM; Serial: TP:1446
- Measurement SW: DASY52, Version 52.10 (2); SEMCAD X Version 14.6.12 (7470)

Area Scan (81x81x1): Interpolated grid: dx=1.000 mm, dy=1.000 mm

Maximum value of SAR (interpolated) = 1.35 W/kg

Zoom Scan (7x7x7)/Cube 0: Measurement grid: dx=4mm, dy=4mm, dz=1.4mm

Reference Value = 17.06 V/m; Power Drift = -0.02 dB

Peak SAR (extrapolated) = 2.96 W/kg

SAR(1 g) = 0.771 W/kg; SAR(10 g) = 0.231 W/kg

Maximum value of SAR (measured) = 1.78 W/kg

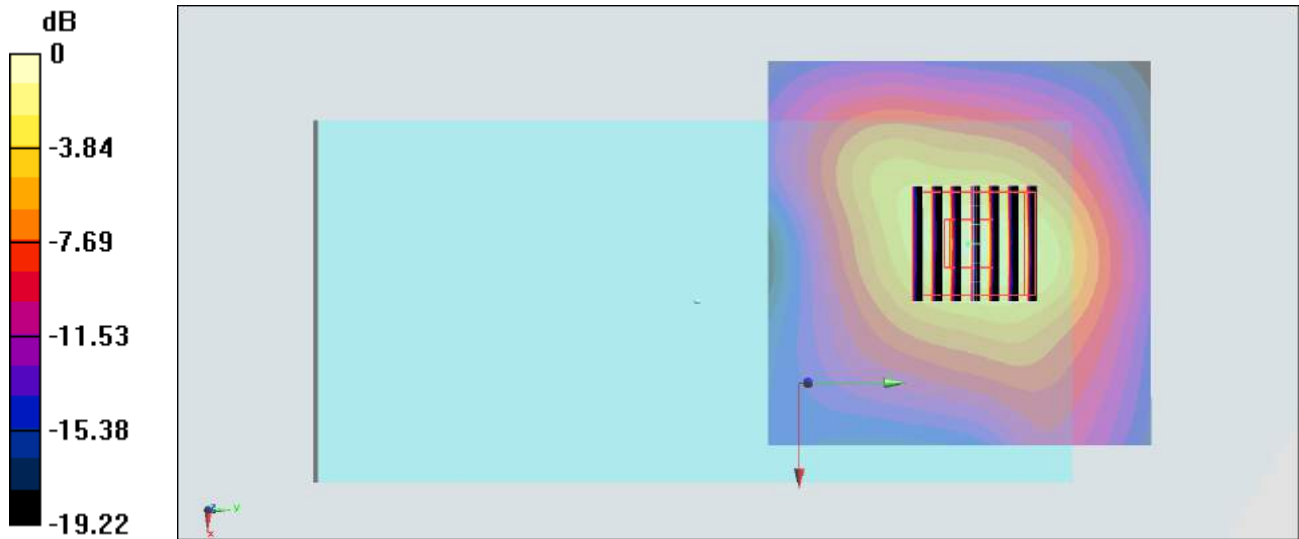

0 dB = 1.78 W/kg = 2.50 dBW/kg

#42_WLAN5GHz_802.11a_6Mbps_Back_5mm_Ch56

Communication System: 802.11a; Frequency: 5280 MHz; Duty Cycle: 1:1.018

Medium: HSL_5G_190817 Medium parameters used: $f = 5280$ MHz; $\sigma = 4.716$ S/m; $\epsilon_r = 36.271$; $\rho = 1000$ kg/m³

Ambient Temperature : 23.7 °C; Liquid Temperature : 22.7 °C

DASY5 Configuration:

- Probe: EX3DV4 - SN3642; ConvF(4.54, 4.54, 4.54) @ 5280 MHz; Calibrated: 2019/4/29
- Sensor-Surface: 1.4mm (Mechanical Surface Detection)
- Electronics: DAE3 Sn360; Calibrated: 2018/10/29
- Phantom: SAM_Right; Type: SAM; Serial: TP:1446
- Measurement SW: DASY52, Version 52.10 (2); SEMCAD X Version 14.6.12 (7470)

Area Scan (81x71x1): Interpolated grid: dx=1.000 mm, dy=1.000 mm

Maximum value of SAR (interpolated) = 3.97 W/kg

Zoom Scan (7x7x7)/Cube 0: Measurement grid: dx=4mm, dy=4mm, dz=1.4mm

Reference Value = 30.82 V/m; Power Drift = -0.02 dB

Peak SAR (extrapolated) = 6.08 W/kg

SAR(1 g) = 0.931 W/kg; SAR(10 g) = 0.326 W/kg

Maximum value of SAR (measured) = 3.64 W/kg

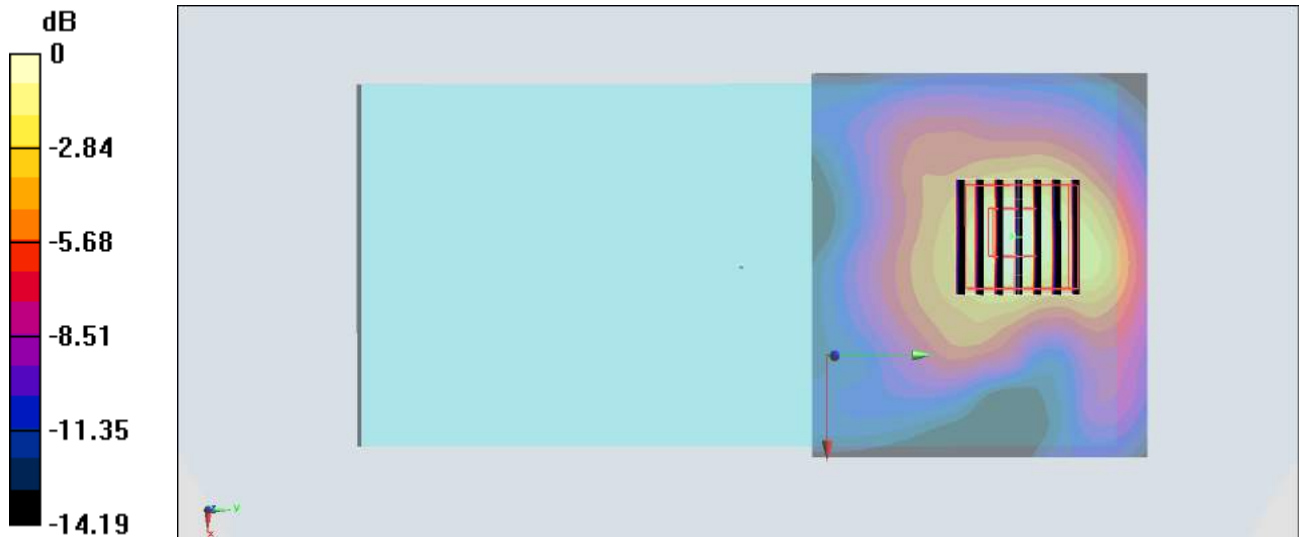

0 dB = 3.64 W/kg = 5.61 dBW/kg

#43_WLAN5GHz_802.11a_6Mbps_Back_5mm_Ch144

Communication System: 802.11a; Frequency: 5720 MHz; Duty Cycle: 1:1.018

Medium: HSL_5G_190817 Medium parameters used: $f = 5720$ MHz; $\sigma = 5.16$ S/m; $\epsilon_r = 35.688$; $\rho = 1000$ kg/m³

Ambient Temperature : 23.7 °C ; Liquid Temperature : 22.7 °C

DASY5 Configuration:

- Probe: EX3DV4 - SN3642; ConvF(4.36, 4.36, 4.36) @ 5720 MHz; Calibrated: 2019/4/29
- Sensor-Surface: 1.4mm (Mechanical Surface Detection)
- Electronics: DAE3 Sn360; Calibrated: 2018/10/29
- Phantom: SAM_Right; Type: SAM; Serial: TP:1446
- Measurement SW: DASY52, Version 52.10 (2); SEMCAD X Version 14.6.12 (7470)

Area Scan (81x71x1): Interpolated grid: dx=1.000 mm, dy=1.000 mm

Maximum value of SAR (interpolated) = 2.76 W/kg

Zoom Scan (7x7x7)/Cube 0: Measurement grid: dx=4mm, dy=4mm, dz=1.4mm

Reference Value = 21.89 V/m; Power Drift = 0.16 dB

Peak SAR (extrapolated) = 4.31 W/kg

SAR(1 g) = 0.665 W/kg; SAR(10 g) = 0.221 W/kg

Maximum value of SAR (measured) = 2.43 W/kg

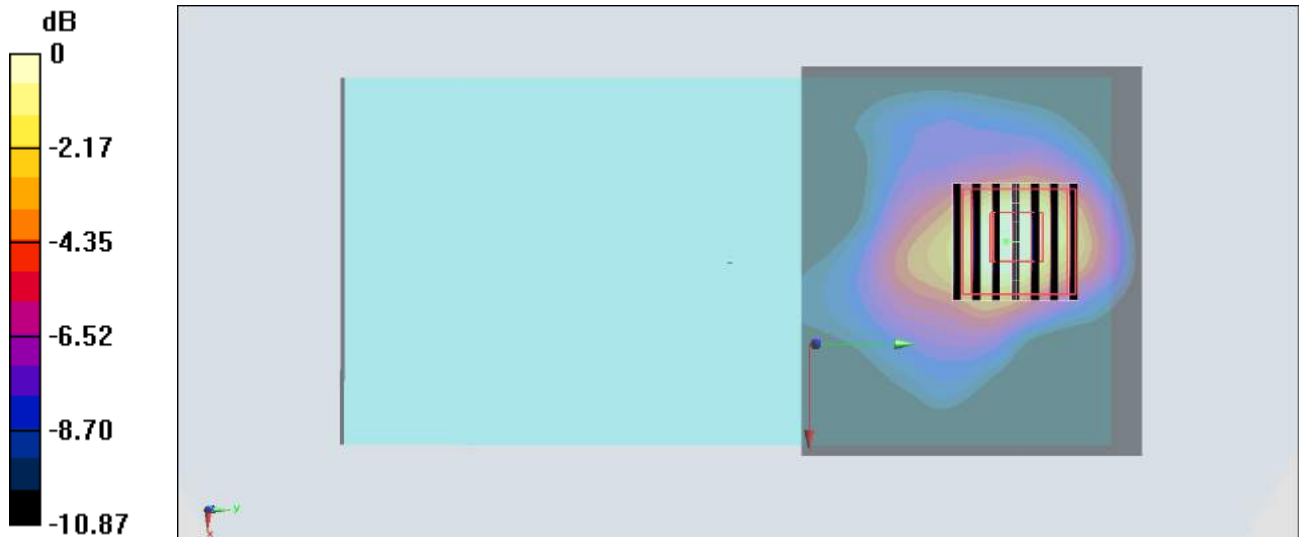

0 dB = 2.43 W/kg = 3.86 dBW/kg

#44_WLAN5GHz_802.11n-HT40 MCS0_Back_5mm_Ch159

Communication System: 802.11n; Frequency: 5795 MHz; Duty Cycle: 1:1.038

Medium: HSL_5G_190816 Medium parameters used: $f = 5795$ MHz; $\sigma = 5.315$ S/m; $\epsilon_r = 36.396$; $\rho = 1000$ kg/m³

Ambient Temperature : 23.3 °C ; Liquid Temperature : 22.3 °C

DASY5 Configuration:

- Probe: EX3DV4 - SN3642; ConvF(4.36, 4.36, 4.36) @ 5795 MHz; Calibrated: 2019/4/29
- Sensor-Surface: 1.4mm (Mechanical Surface Detection)
- Electronics: DAE3 Sn360; Calibrated: 2018/10/29
- Phantom: SAM_Right; Type: SAM; Serial: TP:1446
- Measurement SW: DASY52, Version 52.10 (2); SEMCAD X Version 14.6.12 (7470)

Area Scan (81x71x1): Interpolated grid: dx=1.000 mm, dy=1.000 mm

Maximum value of SAR (interpolated) = 2.98 W/kg

Zoom Scan (7x7x7)/Cube 0: Measurement grid: dx=4mm, dy=4mm, dz=1.4mm

Reference Value = 17.66 V/m; Power Drift = -0.11 dB

Peak SAR (extrapolated) = 4.61 W/kg

SAR(1 g) = 0.689 W/kg; SAR(10 g) = 0.228 W/kg

Maximum value of SAR (measured) = 2.64 W/kg

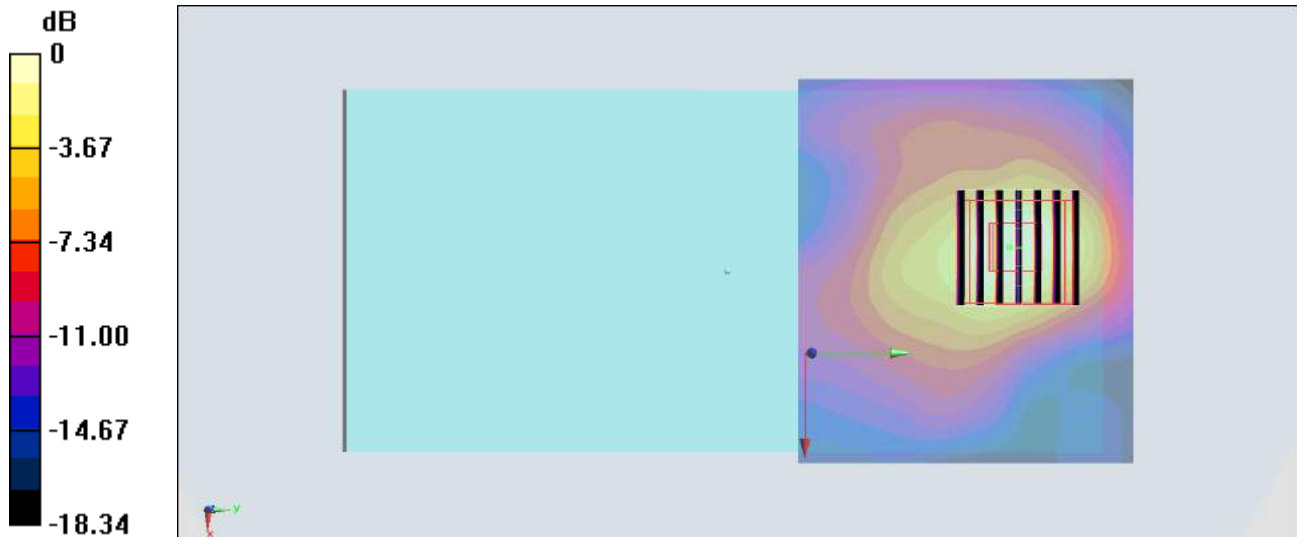

0 dB = 2.64 W/kg = 4.22 dBW/kg

#45_Bluetooth_1Mbps_Back_5mm_Ch39

Communication System: Bluetooth; Frequency: 2441 MHz; Duty Cycle: 1:1.289

Medium: HSL_2450_190815 Medium parameters used: $f = 2441$ MHz; $\sigma = 1.803$ S/m; $\epsilon_r = 38.999$; $\rho = 1000$ kg/m³

Ambient Temperature : 23.8 °C ; Liquid Temperature : 22.8 °C

DASY5 Configuration:

- Probe: EX3DV4 - SN7346; ConvF(7.5, 7.5, 7.5) @ 2441 MHz; Calibrated: 2019/4/25
- Sensor-Surface: 1.4mm (Mechanical Surface Detection)
- Electronics: DAE4 Sn1326; Calibrated: 2018/9/18
- Phantom: Twin-SAM V5.0 (30deg probe tilt); Type: QD 000 P40 CD; Serial: 1885
- Measurement SW: DASY52, Version 52.10 (2); SEMCAD X Version 14.6.12 (7470)

Area Scan (71x71x1): Interpolated grid: dx=1.200 mm, dy=1.200 mm

Maximum value of SAR (interpolated) = 0.146 W/kg

Zoom Scan (9x9x7)/Cube 0: Measurement grid: dx=5mm, dy=5mm, dz=5mm

Reference Value = 9.918 V/m; Power Drift = -0.02 dB

Peak SAR (extrapolated) = 0.245 W/kg

SAR(1 g) = 0.122 W/kg; SAR(10 g) = 0.055 W/kg

Maximum value of SAR (measured) = 0.191 W/kg

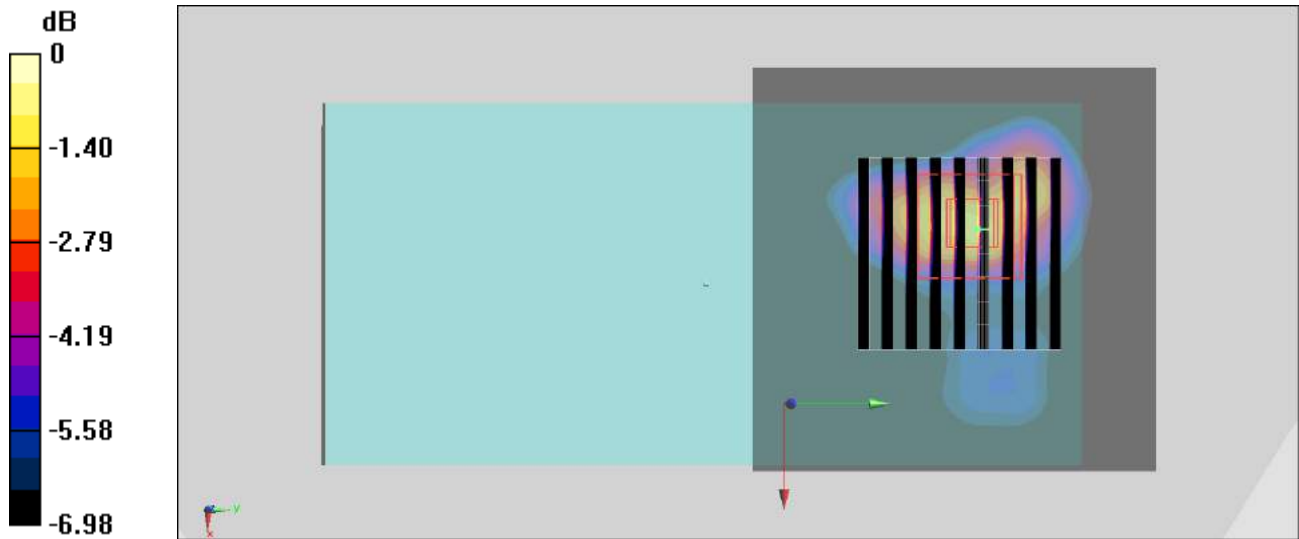

0 dB = 0.191 W/kg = -7.19 dBW/kg

#46_GSM1900_GPRS (2 Tx slots)_Bottom Side_0mm_Ch512

Communication System: PCS; Frequency: 1850.2 MHz; Duty Cycle: 1:4.15

Medium: HSL_1900_190814 Medium parameters used: $f = 1850.2$ MHz; $\sigma = 1.389$ S/m; $\epsilon_r = 39.363$; $\rho = 1000$ kg/m³

Ambient Temperature : 23.2 °C ; Liquid Temperature : 22.2 °C

DASY5 Configuration:

- Probe: EX3DV4 - SN3642; ConvF(7.91, 7.91, 7.91) @ 1850.2 MHz; Calibrated: 2019/4/29
- Sensor-Surface: 1.4mm (Mechanical Surface Detection)
- Electronics: DAE3 Sn360; Calibrated: 2018/10/29
- Phantom: SAM_Left; Type: QD000P40CD; Serial: TP:1815
- Measurement SW: DASY52, Version 52.10 (2); SEMCAD X Version 14.6.12 (7470)

Area Scan (41x61x1): Interpolated grid: dx=1.500 mm, dy=1.500 mm

Maximum value of SAR (interpolated) = 7.54 W/kg

Zoom Scan (5x6x7)/Cube 0: Measurement grid: dx=8mm, dy=8mm, dz=5mm

Reference Value = 54.90 V/m; Power Drift = -0.01 dB

Peak SAR (extrapolated) = 8.85 W/kg

SAR(1 g) = 3.54 W/kg; SAR(10 g) = 1.64 W/kg

Maximum value of SAR (measured) = 6.42 W/kg

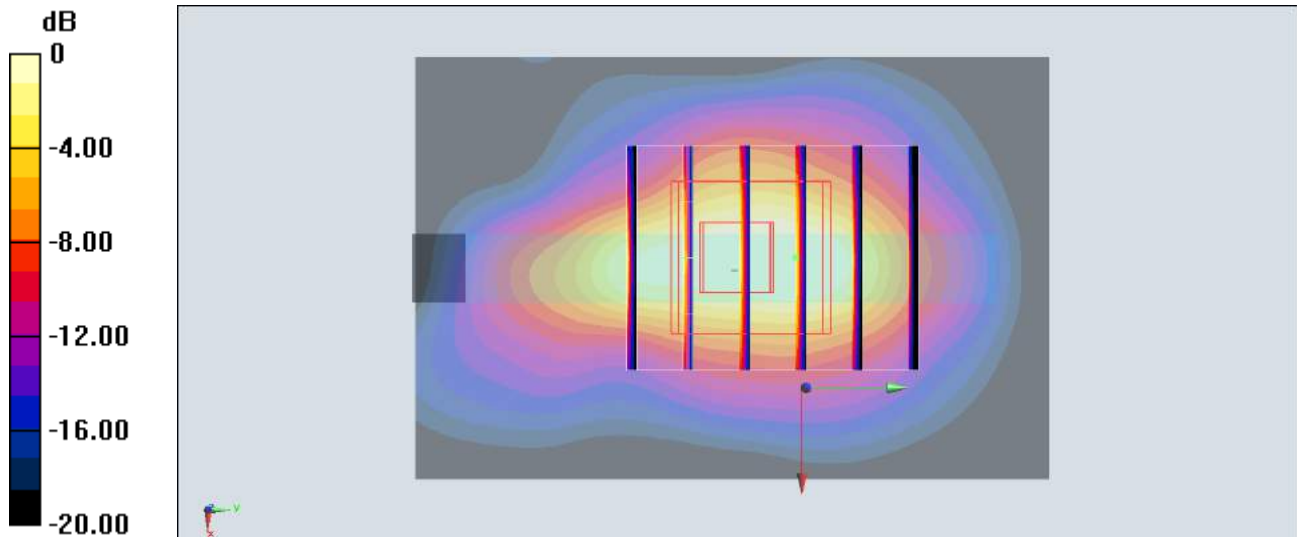

0 dB = 6.42 W/kg = 8.08 dBW/kg

#47_WCDMA II_RMC 12.2Kbps_Back_0mm_Ch9538

Communication System: WCDMA; Frequency: 1907.6 MHz; Duty Cycle: 1:1

Medium: HSL_1900_190814 Medium parameters used: $f = 1908$ MHz; $\sigma = 1.433$ S/m; $\epsilon_r = 38.933$; $\rho = 1000$ kg/m³

Ambient Temperature : 23.2 °C; Liquid Temperature : 22.2 °C

DASY5 Configuration:

- Probe: EX3DV4 - SN3642; ConvF(7.91, 7.91, 7.91) @ 1907.6 MHz; Calibrated: 2019/4/29
- Sensor-Surface: 1.4mm (Mechanical Surface Detection)
- Electronics: DAE3 Sn360; Calibrated: 2018/10/29
- Phantom: SAM_Left; Type: QD000P40CD; Serial: TP:1815
- Measurement SW: DASY52, Version 52.10 (2); SEMCAD X Version 14.6.12 (7470)

Area Scan (71x61x1): Interpolated grid: dx=1.500 mm, dy=1.500 mm

Maximum value of SAR (interpolated) = 11.0 W/kg

Zoom Scan (6x6x7)/Cube 0: Measurement grid: dx=8mm, dy=8mm, dz=5mm

Reference Value = 79.05 V/m; Power Drift = 0.03 dB

Peak SAR (extrapolated) = 14.2 W/kg

SAR(1 g) = 5.36 W/kg; SAR(10 g) = 2.66 W/kg

Maximum value of SAR (measured) = 10.1 W/kg

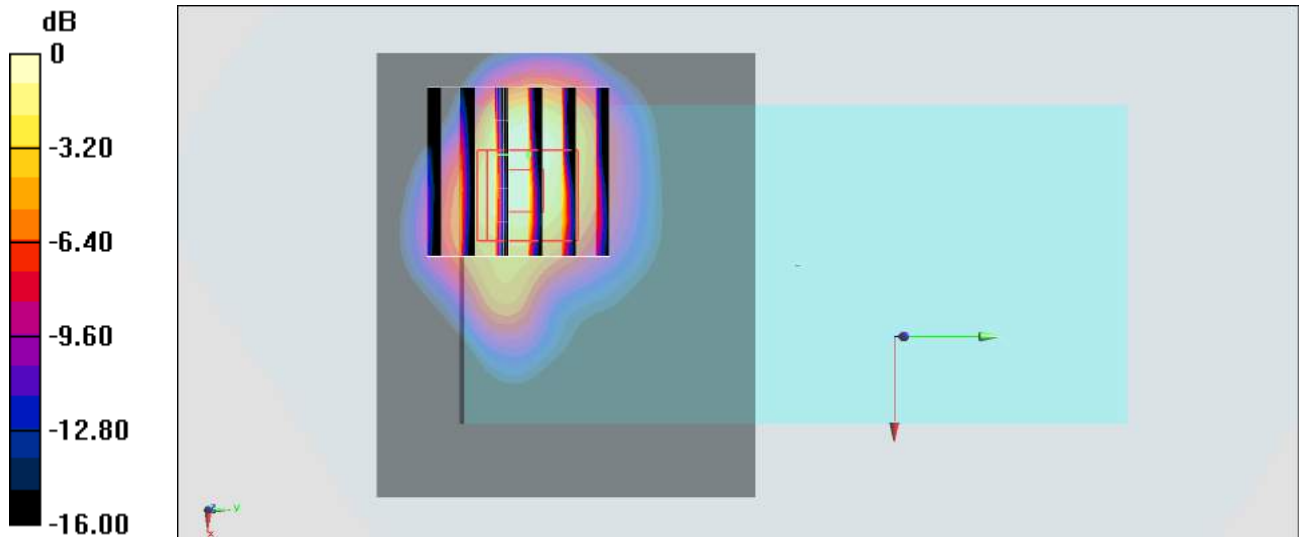

0 dB = 10.1 W/kg = 10.04 dBW/kg

#48_WCDMA IV_RMC 12.2Kbps_Bottom Side_0mm_Ch1312

Communication System: WCDMA; Frequency: 1712.4 MHz; Duty Cycle: 1:1

Medium: HSL_1750_190814 Medium parameters used: $f = 1712.4$ MHz; $\sigma = 1.342$ S/m; $\epsilon_r = 40.923$; $\rho = 1000$ kg/m³

Ambient Temperature : 23.2 °C; Liquid Temperature : 22.2 °C

DASY5 Configuration:

- Probe: EX3DV4 - SN3642; ConvF(8.18, 8.18, 8.18) @ 1712.4 MHz; Calibrated: 2019/4/29
- Sensor-Surface: 1.4mm (Mechanical Surface Detection)
- Electronics: DAE3 Sn360; Calibrated: 2018/10/29
- Phantom: SAM_Left; Type: QD000P40CD; Serial: TP:1815
- Measurement SW: DASY52, Version 52.10 (2); SEMCAD X Version 14.6.12 (7470)

Area Scan (41x61x1): Interpolated grid: dx=1.500 mm, dy=1.500 mm

Maximum value of SAR (interpolated) = 12.7 W/kg

Zoom Scan (5x6x7)/Cube 0: Measurement grid: dx=8mm, dy=8mm, dz=5mm

Reference Value = 84.20 V/m; Power Drift = 0.09 dB

Peak SAR (extrapolated) = 14.0 W/kg

SAR(1 g) = 5.75 W/kg; SAR(10 g) = 2.54 W/kg

Maximum value of SAR (measured) = 11.0 W/kg

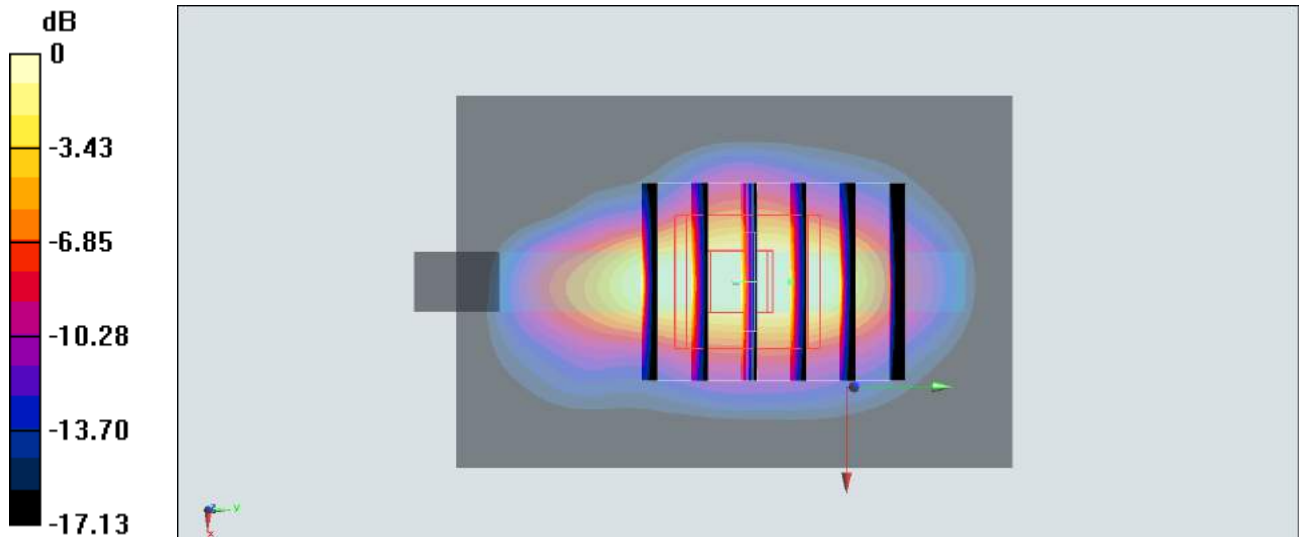

0 dB = 11.0 W/kg = 10.41 dBW/kg

#49_WCDMA V_RMC 12.2Kbps_Back_0mm_Ch4132

Communication System: WCDMA; Frequency: 826.4 MHz; Duty Cycle: 1:1
Medium: HSL_850_190808 Medium parameters used: $f = 826.4$ MHz; $\sigma = 0.876$ S/m; $\epsilon_r = 42.656$;
 $\rho = 1000$ kg/m³
Ambient Temperature : 23.5 °C ; Liquid Temperature : 22.5 °C

DASY5 Configuration

- Probe: ES3DV3 - SN3169; ConvF(6.42, 6.42, 6.42) @ 826.4 MHz; Calibrated: 2019/5/24
- Sensor-Surface: 3mm (Mechanical Surface Detection)
- Electronics: DAE4 Sn1326; Calibrated: 2018/9/18
- Phantom: Twin-SAM V5.0 (30deg probe tilt); Type: QD 000 P40 CD; Serial: 1885
- Measurement SW: DASY52, Version 52.10 (2); SEMCAD X Version 14.6.12 (7450)

Area Scan (61x61x1): Interpolated grid: dx=1.500 mm, dy=1.500 mm
Maximum value of SAR (interpolated) = 5.40 W/kg

Zoom Scan (5x5x7)/Cube 0: Measurement grid: dx=8mm, dy=8mm, dz=5mm
Reference Value = 54.77 V/m; Power Drift = -0.02 dB
Peak SAR (extrapolated) = 11.1 W/kg
SAR(1 g) = 3.76 W/kg; SAR(10 g) = 1.79 W/kg
Maximum value of SAR (measured) = 5.51 W/kg

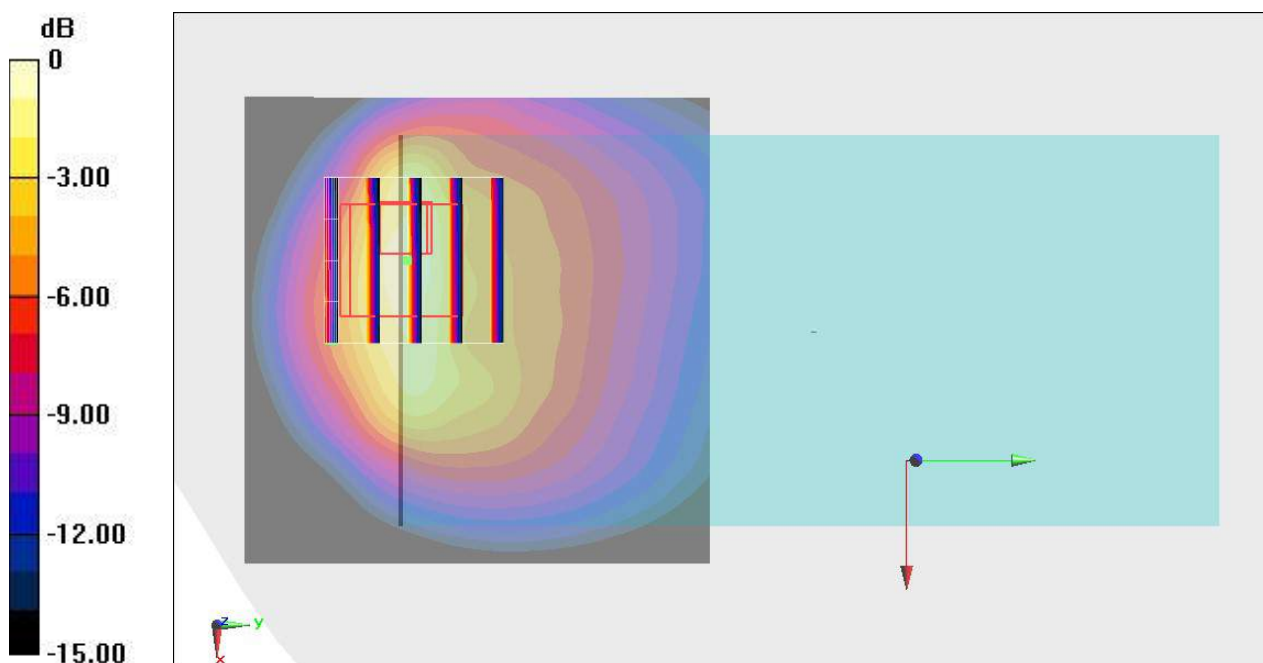

0 dB = 5.51 W/kg = 7.41 dBW/kg

#50_LTE Band 2_20M_QPSK_1_0_Back_0mm_Ch18900

Communication System: LTE; Frequency: 1880 MHz; Duty Cycle: 1:1

Medium: HSL_1900_190814 Medium parameters used: $f = 1880$ MHz; $\sigma = 1.401$ S/m; $\epsilon_r = 39.34$; $\rho = 1000$ kg/m³

Ambient Temperature : 23.2 °C ; Liquid Temperature : 22.2 °C

DASY5 Configuration:

- Probe: EX3DV4 - SN3642; ConvF(7.91, 7.91, 7.91) @ 1880 MHz; Calibrated: 2019/4/29
- Sensor-Surface: 1.4mm (Mechanical Surface Detection)
- Electronics: DAE3 Sn360; Calibrated: 2018/10/29
- Phantom: SAM_Left; Type: QD000P40CD; Serial: TP:1815
- Measurement SW: DASY52, Version 52.10 (2); SEMCAD X Version 14.6.12 (7470)

Area Scan (71x61x1): Interpolated grid: dx=1.500 mm, dy=1.500 mm

Maximum value of SAR (interpolated) = 10.6 W/kg

Zoom Scan (6x6x7)/Cube 0: Measurement grid: dx=8mm, dy=8mm, dz=5mm

Reference Value = 76.48 V/m; Power Drift = -0.05 dB

Peak SAR (extrapolated) = 13.2 W/kg

SAR(1 g) = 5.25 W/kg; SAR(10 g) = 2.73 W/kg

Maximum value of SAR (measured) = 9.97 W/kg

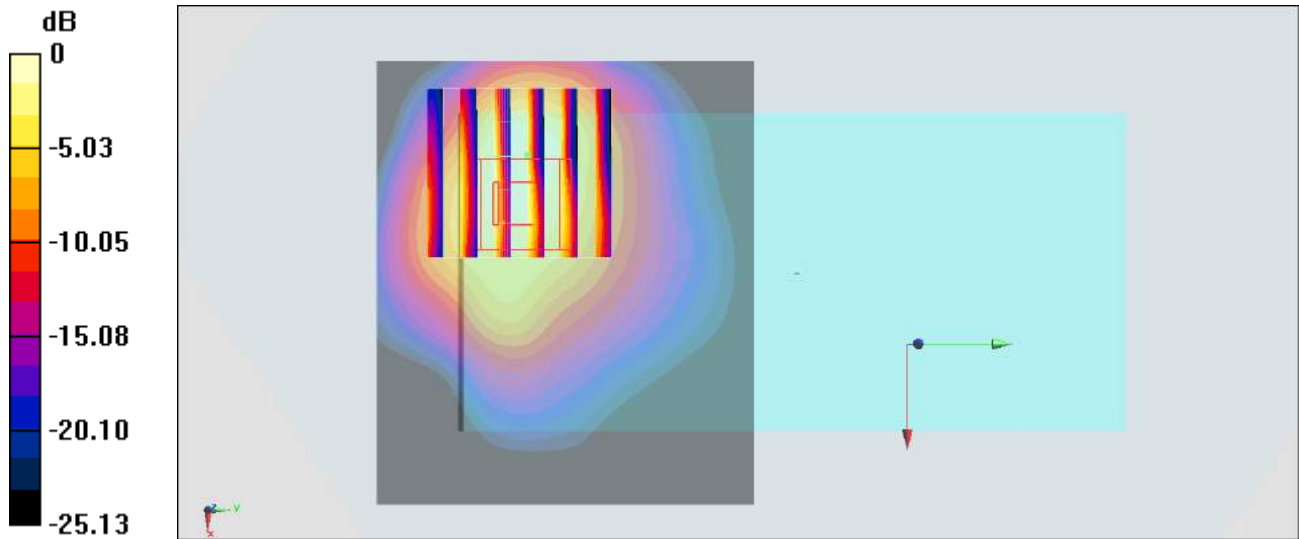

0 dB = 9.97 W/kg = 9.99 dBW/kg

#51_LTE Band 4_20M_QPSK_1_0_Bottom Side_0mm_Ch20175

Communication System: LTE; Frequency: 1732.5 MHz; Duty Cycle: 1:1

Medium: HSL_1750_190814 Medium parameters used: $f = 1733$ MHz; $\sigma = 1.38$ S/m; $\epsilon_r = 40.654$; $\rho = 1000$ kg/m³

Ambient Temperature : 23.2 °C ; Liquid Temperature : 22.2 °C

DASY5 Configuration:

- Probe: EX3DV4 - SN3642; ConvF(8.18, 8.18, 8.18) @ 1732.5 MHz; Calibrated: 2019/4/29
- Sensor-Surface: 1.4mm (Mechanical Surface Detection)
- Electronics: DAE3 Sn360; Calibrated: 2018/10/29
- Phantom: SAM_Left; Type: QD000P40CD; Serial: TP:1815
- Measurement SW: DASY52, Version 52.10 (2); SEMCAD X Version 14.6.12 (7470)

Area Scan (41x61x1): Interpolated grid: dx=1.500 mm, dy=1.500 mm

Maximum value of SAR (interpolated) = 14.2 W/kg

Zoom Scan (5x6x7)/Cube 0: Measurement grid: dx=8mm, dy=8mm, dz=5mm

Reference Value = 96.35 V/m; Power Drift = -0.08 dB

Peak SAR (extrapolated) = 17.0 W/kg

SAR(1 g) = 6.43 W/kg; SAR(10 g) = 2.89 W/kg

Maximum value of SAR (measured) = 12.0 W/kg

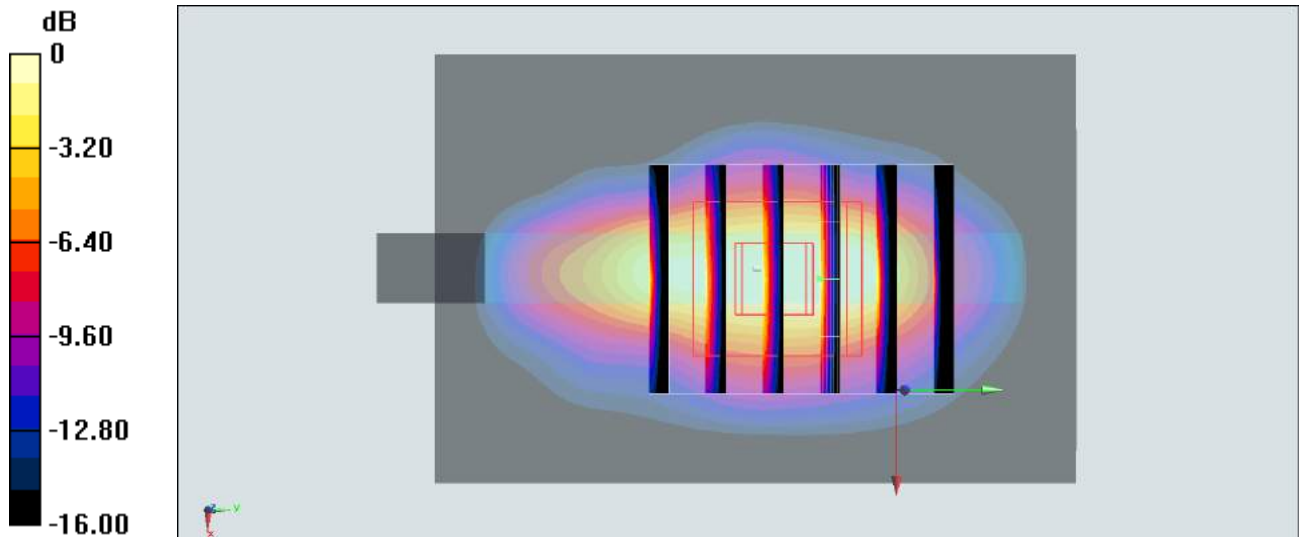

0 dB = 12.0 W/kg = 10.79 dBW/kg

#52_LTE Band 7_20M_QPSK_1_0_Back_0mm_Ch21350

Communication System: LTE; Frequency: 2560 MHz; Duty Cycle: 1:1
Medium: HSL_2600_190814 Medium parameters used: $f = 2560$ MHz; $\sigma = 1.876$ S/m; $\epsilon_r = 38.523$;
 $\rho = 1000$ kg/m³
Ambient Temperature : 23.8 °C ; Liquid Temperature : 22.8 °C

DASY5 Configuration

- Probe: EX3DV4 - SN7346; ConvF(7.31, 7.31, 7.31) @ 2560 MHz; Calibrated: 2019/4/25
- Sensor-Surface: 1.4mm (Mechanical Surface Detection)
- Electronics: DAE4 Sn1326; Calibrated: 2018/9/18
- Phantom: Twin-SAM V5.0 (30deg probe tilt); Type: QD 000 P40 CD; Serial: 1885
- Measurement SW: DASY52, Version 52.10 (2); SEMCAD X Version 14.6.12 (7450)

Area Scan (81x81x1): Interpolated grid: dx=1.200 mm, dy=1.200 mm
Maximum value of SAR (interpolated) = 14.8 W/kg

Zoom Scan (7x7x7)/Cube 0: Measurement grid: dx=5mm, dy=5mm, dz=5mm
Reference Value = 35.71 V/m; Power Drift = -0.19 dB
Peak SAR (extrapolated) = 20.5 W/kg
SAR(1 g) = 7.35 W/kg; SAR(10 g) = 3.02 W/kg
Maximum value of SAR (measured) = 14.4 W/kg

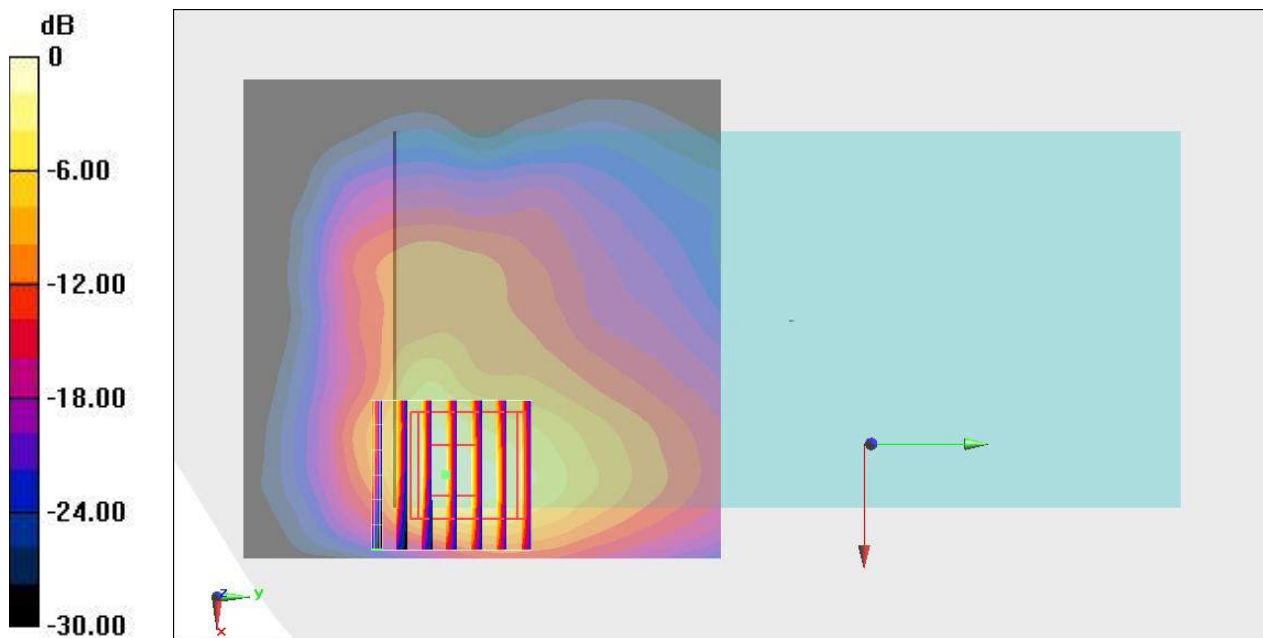

0 dB = 14.4 W/kg = 11.58 dBW/kg

#52_LTE Band 26_15M_QPSK_1_37_Back_0mm_Ch26865

Communication System: LTE; Frequency: 831.5 MHz; Duty Cycle: 1:1

Medium: HSL_850_190808 Medium parameters used: $f = 831.5$ MHz; $\sigma = 0.881$ S/m; $\epsilon_r = 42.587$; $\rho = 1000$ kg/m³

Ambient Temperature : 23.5 °C ; Liquid Temperature : 22.5 °C

DASY5 Configuration:

- Probe: ES3DV3 - SN3169; ConvF(6.42, 6.42, 6.42) @ 831.5 MHz; Calibrated: 2019/5/24
- Sensor-Surface: 3mm (Mechanical Surface Detection)
- Electronics: DAE4 Sn1326; Calibrated: 2018/9/18
- Phantom: Twin-SAM V5.0 (30deg probe tilt); Type: QD 000 P40 CD; Serial: 1885
- Measurement SW: DASY52, Version 52.10 (2); SEMCAD X Version 14.6.12 (7470)

Area Scan (61x61x1): Interpolated grid: dx=1.500 mm, dy=1.500 mm

Maximum value of SAR (interpolated) = 4.34 W/kg

Zoom Scan (6x6x7)/Cube 0: Measurement grid: dx=8mm, dy=8mm, dz=5mm

Reference Value = 48.46 V/m; Power Drift = 0.12 dB

Peak SAR (extrapolated) = 9.16 W/kg

SAR(1 g) = 3.26 W/kg; SAR(10 g) = 1.57 W/kg

Maximum value of SAR (measured) = 4.47 W/kg

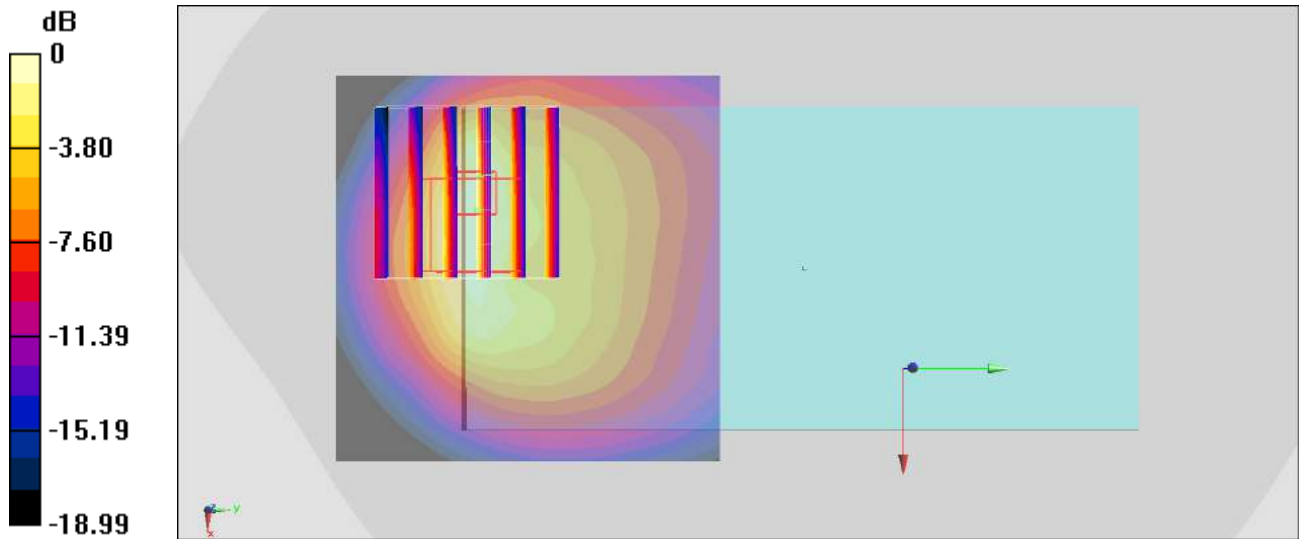

0 dB = 4.47 W/kg = 6.50 dBW/kg

#54_LTE Band 41_20M_QPSK_1_49_Back_0mm_Ch40670

Communication System: LTE; Frequency: 2598 MHz; Duty Cycle: 1:1.59
Medium: HSL_2600_190814 Medium parameters used: $f = 2598$ MHz; $\sigma = 1.918$ S/m; $\epsilon_r = 38.405$;
 $\rho = 1000$ kg/m³
Ambient Temperature : 23.8 °C ; Liquid Temperature : 22.8 °C

DASY5 Configuration

- Probe: EX3DV4 - SN7346; ConvF(7.31, 7.31, 7.31) @ 2598 MHz; Calibrated: 2019/4/25
- Sensor-Surface: 1.4mm (Mechanical Surface Detection)
- Electronics: DAE4 Sn1326; Calibrated: 2018/9/18
- Phantom: Twin-SAM V5.0 (30deg probe tilt); Type: QD 000 P40 CD; Serial: 1885
- Measurement SW: DASY52, Version 52.10 (2); SEMCAD X Version 14.6.12 (7450)

Area Scan (81x81x1): Interpolated grid: dx=1.200 mm, dy=1.200 mm
Maximum value of SAR (interpolated) = 8.27 W/kg

Zoom Scan (7x7x7)/Cube 0: Measurement grid: dx=5mm, dy=5mm, dz=5mm
Reference Value = 20.83 V/m; Power Drift = -0.16 dB
Peak SAR (extrapolated) = 10.4 W/kg
SAR(1 g) = 3.65 W/kg; SAR(10 g) = 1.52 W/kg
Maximum value of SAR (measured) = 6.77 W/kg

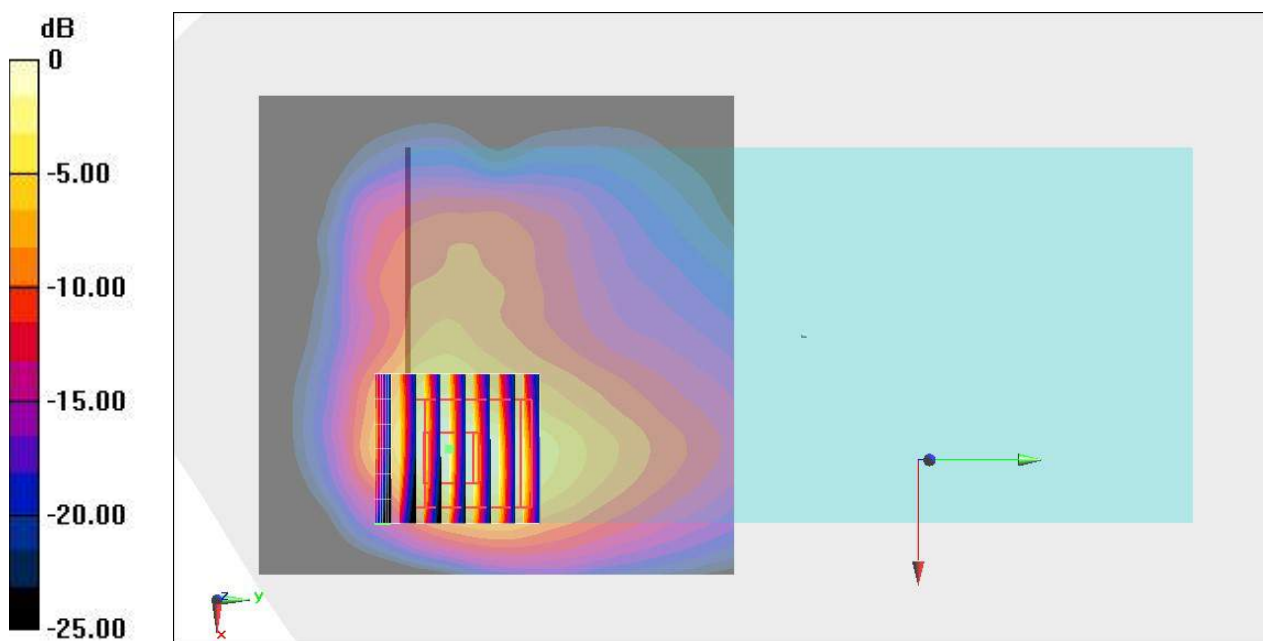

0 dB = 6.77 W/kg = 8.31 dBW/kg

#55_WLAN5GHz_802.11a_6Mbps_Back_0mm_Ch64

Communication System: 802.11a; Frequency: 5320 MHz; Duty Cycle: 1:1.018

Medium: HSL_5G_190817 Medium parameters used: $f = 5320$ MHz; $\sigma = 4.755$ S/m; $\epsilon_r = 36.205$; $\rho = 1000$ kg/m³

Ambient Temperature : 23.7 °C ; Liquid Temperature : 22.7 °C

DASY5 Configuration:

- Probe: EX3DV4 - SN3642; ConvF(4.54, 4.54, 4.54) @ 5320 MHz; Calibrated: 2019/4/29
- Sensor-Surface: 1.4mm (Mechanical Surface Detection)
- Electronics: DAE3 Sn360; Calibrated: 2018/10/29
- Phantom: SAM_Right; Type: SAM; Serial: TP:1446
- Measurement SW: DASY52, Version 52.10 (2); SEMCAD X Version 14.6.12 (7470)

Area Scan (81x81x1): Interpolated grid: dx=1.000 mm, dy=1.000 mm

Maximum value of SAR (interpolated) = 10.2 W/kg

Zoom Scan (8x8x7)/Cube 0: Measurement grid: dx=4mm, dy=4mm, dz=1.4mm

Reference Value = 57.65 V/m; Power Drift = -0.11 dB

Peak SAR (extrapolated) = 26.7 W/kg

SAR(1 g) = 3.72 W/kg; SAR(10 g) = 1.18 W/kg

Maximum value of SAR (measured) = 14.6 W/kg

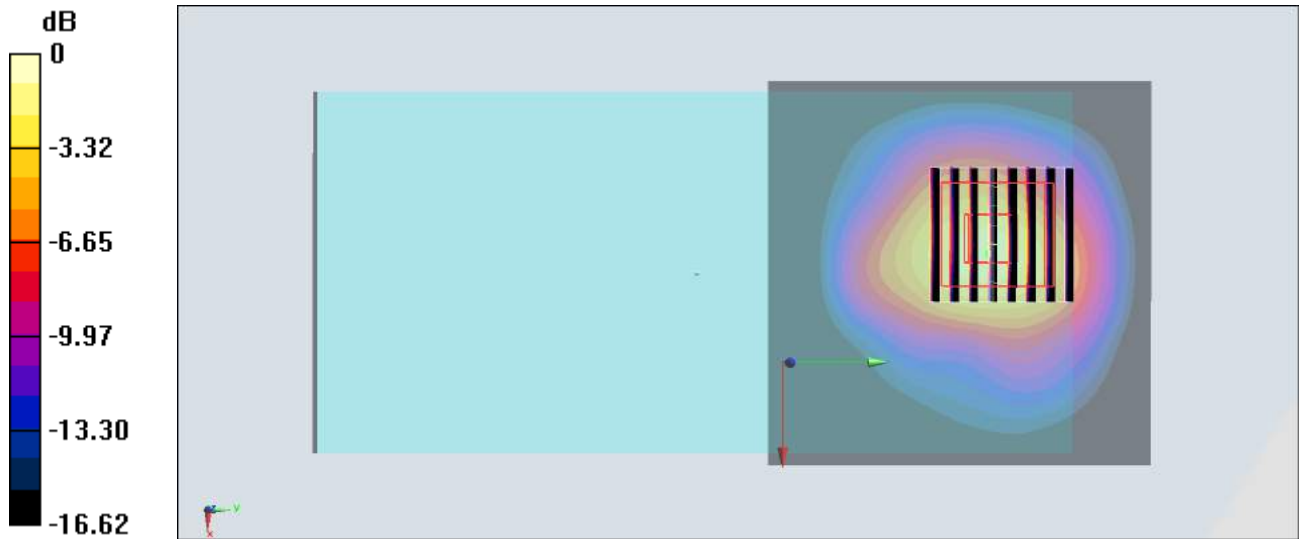

0 dB = 14.6 W/kg = 11.64 dBW/kg

#56_WLAN5GHz_802.11a_6Mbps_Back_0mm_Ch100

Communication System: 802.11a; Frequency: 5500 MHz; Duty Cycle: 1:1.018

Medium: HSL_5G_190817 Medium parameters used: $f = 5500$ MHz; $\sigma = 4.927$ S/m; $\epsilon_r = 35.981$; $\rho = 1000$ kg/m³

Ambient Temperature : 23.7 °C ; Liquid Temperature : 22.7 °C

DASY5 Configuration:

- Probe: EX3DV4 - SN3642; ConvF(4.28, 4.28, 4.28) @ 5500 MHz; Calibrated: 2019/4/29
- Sensor-Surface: 1.4mm (Mechanical Surface Detection)
- Electronics: DAE3 Sn360; Calibrated: 2018/10/29
- Phantom: SAM_Right; Type: SAM; Serial: TP:1446
- Measurement SW: DASY52, Version 52.10 (2); SEMCAD X Version 14.6.12 (7470)

Area Scan (81x81x1): Interpolated grid: dx=1.000 mm, dy=1.000 mm

Maximum value of SAR (interpolated) = 10.7 W/kg

Zoom Scan (8x8x7)/Cube 0: Measurement grid: dx=4mm, dy=4mm, dz=1.4mm

Reference Value = 59.17 V/m; Power Drift = -0.03 dB

Peak SAR (extrapolated) = 30.7 W/kg

SAR(1 g) = 4.26 W/kg; SAR(10 g) = 1.3 W/kg

Maximum value of SAR (measured) = 17.0 W/kg

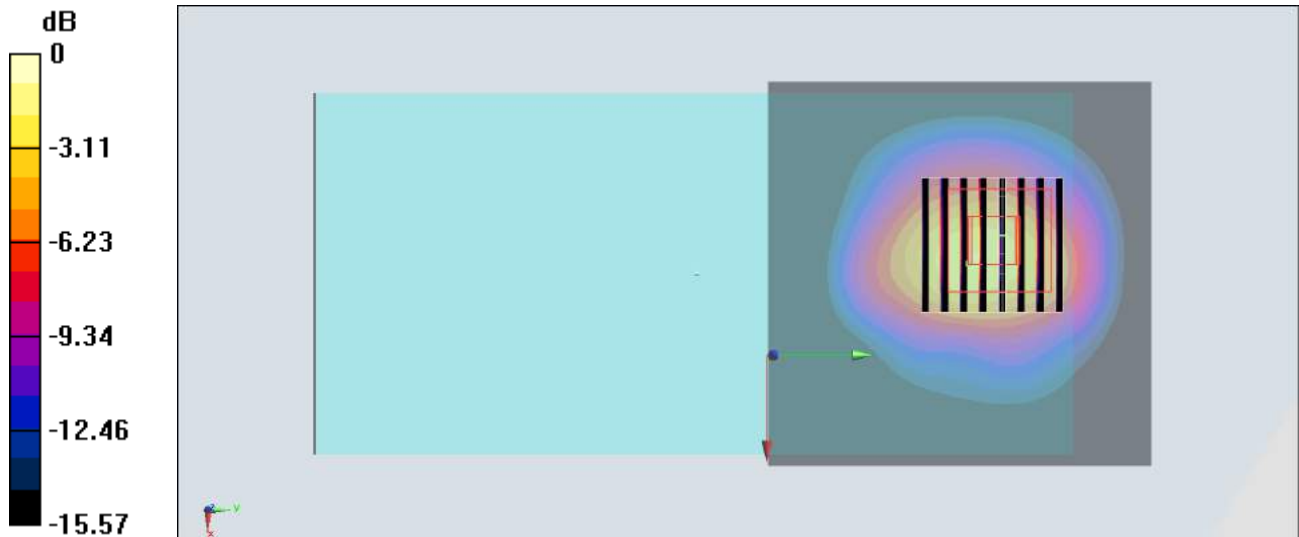

0 dB = 17.0 W/kg = 12.30 dBW/kg