



FCC RADIO TEST REPORT

FCC ID : IHDT56YC1
Equipment : Mobile Cellular Phone
Brand Name : Motorola
Model Name : XT2010-1
Applicant : Motorola Mobility LLC
222 W,Merchandise Mart Plaza, Chicago IL
60654 USA
Manufacturer : Motorola Mobility LLC
222 W,Merchandise Mart Plaza, Chicago IL
60654 USA
Standard : FCC Part 15 Subpart E §15.407

The product was received on Apr. 26, 2019 and testing was started from May 07, 2019 and completed on May 27, 2019. We, SPORTON INTERNATIONAL INC., EMC & Wireless Communications Laboratory, would like to declare that the tested sample has been evaluated in accordance with the test procedures and has been in compliance with the applicable technical standards.

The report must not be used by the client to claim product certification, approval, or endorsement by TAF or any agency of government.

The test results in this report apply exclusively to the tested model / sample. Without written approval of SPORTON INTERNATIONAL INC. EMC & Wireless Communications Laboratory, the test report shall not be reproduced except in full.

Approved by: Jones Tsai

SPORTON INTERNATIONAL INC. EMC & Wireless Communications Laboratory
No. 52, Huaya 1st Rd., Guishan Dist., Taoyuan City, Taiwan (R.O.C.)



Table of Contents

History of this test report.....	3
Summary of Test Result.....	4
1 General Description	5
1.1 Product Feature of Equipment Under Test.....	5
1.2 Product Specification of Equipment Under Test.....	7
1.3 Modification of EUT	7
1.4 Testing Location	8
1.5 Applicable Standards.....	8
2 Test Configuration of Equipment Under Test	9
2.1 Carrier Frequency and Channel	9
2.2 Test Mode.....	10
2.3 Connection Diagram of Test System.....	12
2.4 Support Unit used in test configuration and system	13
2.5 EUT Operation Test Setup	13
2.6 Measurement Results Explanation Example.....	13
3 Test Result	14
3.1 26dB & 99% Occupied Bandwidth Measurement	14
3.2 Maximum Conducted Output Power Measurement	16
3.3 Power Spectral Density Measurement	18
3.4 Unwanted Emissions Measurement.....	20
3.5 AC Conducted Emission Measurement.....	25
3.6 Automatically Discontinue Transmission	27
3.7 Antenna Requirements	28
4 List of Measuring Equipment.....	29
5 Uncertainty of Evaluation	31
Appendix A. Conducted Test Results	
Appendix B. AC Conducted Emission Test Result	
Appendix C. Radiated Spurious Emission	
Appendix D. Radiated Spurious Emission Plots	
Appendix E. Duty Cycle Plots	



History of this test report

Report No.	Version	Description	Issued Date
FR942629E	01	Initial issue of report	Jun. 06, 2019



Summary of Test Result

Report Clause	Ref Std. Clause	Test Items	Result (PASS/FAIL)	Remark
3.1	15.403(i)	26dB Bandwidth	Pass	-
3.1	2.1049	99% Occupied Bandwidth	Reporting only	-
3.2	15.407(a)	Maximum Conducted Output Power	Pass	-
3.3	15.407(a)	Power Spectral Density	Pass	-
3.4	15.407(b)	Unwanted Emissions	Pass	Under limit 4.30 dB at 5350.560 MHz
3.5	15.207	AC Conducted Emission	Pass	Under limit 18.20 dB at 0.575 MHz
3.6	15.407(c)	Automatically Discontinue Transmission	Pass	-
3.7	15.203 15.407(a)	Antenna Requirement	Pass	-

Declaration of Conformity:

The test results with all measurement uncertainty excluded are presented in accordance with the regulation limits or requirements declared by manufacturers.

Comments and Explanations:

The declared of product specification for EUT presented in the report are provided by the manufacturer, and the manufacturer takes all the responsibilities for the accuracy of product specification.

Reviewed by: Wii Chang

Report Producer: Dara Chiu



1 General Description

1.1 Product Feature of Equipment Under Test

Product Feature	
Equipment	Mobile Cellular Phone
Brand Name	Motorola
Model Name	XT2010-1
FCC ID	IHDT56YC1
Sample 1	Single SIM
Sample 2	Dual SIM
IMEI Code	Conducted : IMEI: 354156100004763 Conduction : IMEI: 354156100005315 Radiation : IMEI: 354156100005430
EUT supports Radios application	GSM/EGPRS/WCDMA/HSPA/LTE/GNSS/NFC/FM WLAN 11b/g/n HT20 WLAN 11a/n HT20/HT40 WLAN 11ac VHT20/VHT40/VHT80 Bluetooth BR/EDR/LE
HW Version	DVT2A
EUT Stage	Identical Prototype

Remark: The above EUT's information was declared by manufacturer.



Accessory List	
AC Adapter 1 (US)	Brand Name : Motorola
	Model Name : SC-51
	Manufacturer : Salom
AC Adapter 1 (EU)	Brand Name : Motorola
	Model Name : SC-52
	Manufacturer : Salom
AC Adapter 1 (UK)	Brand Name : Motorola
	Model Name : SC-53
	Manufacturer : Salom
AC Adapter 1 (AR)	Brand Name : Motorola
	Model Name : SC-56
	Manufacturer : Salom
AC Adapter 1 (BR)	Brand Name : Motorola
	Model Name : SC-57
	Manufacturer : Salom
AC Adapter 2 (US)	Brand Name : Motorola
	Model Name : SC-51
	Manufacturer : Chenyang
AC Adapter 2 (EU)	Brand Name : Motorola
	Model Name : SC-52
	Manufacturer : Chenyang
AC Adapter 2 (UK)	Brand Name : Motorola
	Model Name : SC-53
	Manufacturer : Chenyang
AC Adapter 2 (AR)	Brand Name : Motorola
	Model Name : SC-56
	Manufacturer : Chenyang
AC Adapter 3 (BR)	Brand Name : Motorola
	Model Name : SC-57
	Manufacturer : Flex
AC Adapter 4 (BR)	Brand Name : Motorola
	Model Name : SC-57
	Manufacturer : Cliptech
Battery 1	Brand Name : Motorola
	Model Name : KP50
	Manufacturer : SCUD
Earphone 1	Brand Name : Motorola
	Model Name : SH38C37773
	Manufacturer : Lianyun
Earphone 2	Brand Name : Motorola
	Model Name : SH38C44959
	Manufacturer : Cosonic
USB Cable 1	Brand Name : Luxshare
	Model Name : SC18C24368
USB Cable 2	Brand Name : Saibao
	Model Name : SC18C24367

1.2 Product Specification of Equipment Under Test

Standards-related Product Specification	
Tx/Rx Frequency Range	5180 MHz ~ 5240 MHz 5260 MHz ~ 5320 MHz 5500 MHz ~ 5700 MHz
Maximum Output Power to Antenna	<p><5180 MHz ~ 5240 MHz> 802.11a : 16.70 dBm / 0.0468 W 802.11n HT20 : 15.70 dBm / 0.0372 W 802.11n HT40 : 15.60 dBm / 0.0363 W 802.11ac VHT20 : 14.70 dBm / 0.0295 W 802.11ac VHT40 : 14.60 dBm / 0.0288 W 802.11ac VHT80 : 14.60 dBm / 0.0288 W</p> <p><5260 MHz ~ 5320 MHz> 802.11a : 16.80 dBm / 0.0479 W 802.11n HT20 : 15.70 dBm / 0.0372 W 802.11n HT40 : 15.80 dBm / 0.0380 W 802.11ac VHT20 : 14.80 dBm / 0.0302 W 802.11ac VHT40 : 14.70 dBm / 0.0295 W 802.11ac VHT80 : 14.70 dBm / 0.0295 W</p> <p><5500 MHz ~ 5700 MHz > 802.11a : 16.70 dBm / 0.0468 W 802.11n HT20 : 15.80 dBm / 0.0380 W 802.11n HT40 : 15.80 dBm / 0.0380 W 802.11ac VHT20 : 14.80 dBm / 0.0302 W 802.11ac VHT40 : 14.80 dBm / 0.0302 W 802.11ac VHT80 : 14.50 dBm / 0.0282 W</p>
99% Occupied Bandwidth	802.11a : 16.80 MHz 802.11n HT20 : : 17.95 MHz 802.11n HT40 : 36.60 MHz 802.11 ac VHT80 : 76.92 MHz
Antenna Type / Gain	<p><5150 MHz ~ 5250 MHz> Loop Antenna type with gain -8.00 dBi</p> <p><5250 MHz ~ 5350 MHz> Loop Antenna type with gain -8.00 dBi</p> <p><5470 MHz ~ 5700 MHz> Loop Antenna type with gain -8.00 dBi</p>
Type of Modulation	802.11a/n : OFDM (BPSK / QPSK / 16QAM / 64QAM) 802.11ac: OFDM (BPSK / QPSK / 16QAM / 64QAM / 256QAM)

Note: The WLAN operation in 5600 MHz ~ 5650 MHz is notched.

1.3 Modification of EUT

No modifications are made to the EUT during all test items.



1.4 Testing Location

Test Site	SPORTON INTERNATIONAL INC.	
Test Site Location	No.52, Huaya 1st Rd., Guishan Dist., Taoyuan City, Taiwan (R.O.C.) TEL: +886-3-327-3456 FAX: +886-3-328-4978	
Test Site No.	Sporton Site No.	
	TH05-HY	CO05-HY

Note: The test site complies with ANSI C63.4 2014 requirement.

Test Site	SPORTON INTERNATIONAL INC.	
Test Site Location	No.58, Aly. 75, Ln. 564, Wenhua 3rd, Rd., Guishan Dist., Taoyuan City, Taiwan (R.O.C.) TEL: +886-3-327-0868 FAX: +886-3-327-0855	
Test Site No.	Sporton Site No.	
	03CH15-HY	

Note: The test site complies with ANSI C63.4 2014 requirement.

FCC designation No.: TW1190 and TW0007

1.5 Applicable Standards

According to the specifications of the manufacturer, the EUT must comply with the requirements of the following standards:

- ♦ FCC Part 15 Subpart E
- ♦ FCC KDB 789033 D02 General UNII Test Procedures New Rules v02r01.
- ♦ FCC KDB 414788 D01 Radiated Test Site v01r01.
- ♦ ANSI C63.10-2013

Remark:

1. All test items were verified and recorded according to the standards and without any deviation during the test.
2. This EUT has also been tested and complied with the requirements of FCC Part 15, Subpart B, recorded in a separate test report.



2 Test Configuration of Equipment Under Test

- a. The EUT has been associated with peripherals and configuration operated in a manner tended to maximize its emission characteristics in a typical application. Frequency range investigated: conduction emission (150 kHz to 30 MHz), radiation emission (9 kHz to the 10th harmonic of the highest fundamental frequency or to 40 GHz, whichever is lower). For radiated measurement, pre-scanned in three orthogonal panels, X, Y, Z. The worst cases (X plane) were recorded in this report.
- b. AC power line Conducted Emission was tested under maximum output power.

2.1 Carrier Frequency and Channel

Frequency Band	Channel	Freq. (MHz)	Channel	Freq. (MHz)
5150-5250 MHz Band 1 (U-NII-1)	36	5180	44	5220
	38*	5190	46*	5230
	40	5200	48	5240
	42 [#]	5210		

Frequency Band	Channel	Freq. (MHz)	Channel	Freq. (MHz)
5250-5350 MHz Band 2 (U-NII-2A)	52	5260	60	5300
	54*	5270	62*	5310
	56	5280	64	5320
	58 [#]	5290		

Frequency Band	Channel	Freq. (MHz)	Channel	Freq. (MHz)
5470-5725 MHz Band 3 (U-NII-2C)	100	5500	112	5560
	102*	5510	116	5580
	104	5520	132	5660
	106 [#]	5530	134*	5670
	108	5540	136	5680
	110*	5550	140	5700

Note:

1. The above Frequency and Channel in "*" were 802.11n HT40 and 802.11ac VHT40.
2. The above Frequency and Channel in "[#]" were 802.11ac VHT80.



2.2 Test Mode

Final test modes are considering the modulation and worse data rates as below table.

Modulation	Data Rate
802.11a	6 Mbps
802.11n HT20	MCS0
802.11n HT40	MCS0
802.11ac VHT20 (Covered by HT20)	MCS0
802.11ac VHT40 (Covered by HT40)	MCS0
802.11ac VHT80	MCS0

Test Cases	
AC Conducted Emission	Mode 1: LTE Band 12 Low Channel Idle + Bluetooth Link + WLAN (5GHz) Link + Camera (Back) + Battery + Earphone 2 + USB Cable 2 (Charging from AC Adapter 4 (Cliptech_BR)) for Sample 1
Remark: For Radiated Test Cases, the tests were performed with AC Adapter 1 (Salom_US), Earphone 1, USB Cable 1, and Sample 1	



Ch. #		Band I : 5150-5250 MHz	Band II : 5250-5350 MHz	Band III : 5470-5725MHz
		802.11a	802.11a	802.11a
L	Low	36	52	100
M	Middle	44	60	116
H	High	48	64	140

Ch. #		Band I : 5150-5250 MHz	Band II : 5250-5350 MHz	Band III : 5470-5725MHz
		802.11n HT20	802.11n HT20	802.11n HT20
L	Low	36	52	100
M	Middle	44	60	116
H	High	48	64	140

Ch. #		Band I : 5150-5250 MHz	Band II : 5250-5350 MHz	Band III : 5470-5725MHz
		802.11n HT40	802.11n HT40	802.11n HT40
L	Low	38	54	102
M	Middle	-	-	110
H	High	46	62	134

Ch. #		Band I : 5150-5250 MHz	Band II : 5250-5350 MHz	Band III : 5470-5725MHz
		802.11ac VHT80	802.11ac VHT80	802.11ac VHT80
L	Low	-	-	106
M	Middle	42	58	-
H	High	-	-	-

2.3 Connection Diagram of Test System

<WLAN Tx Mode>

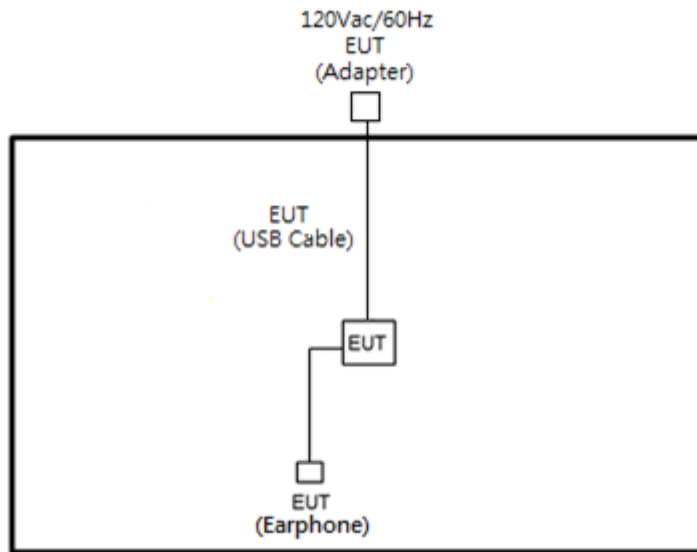

<AC Conducted Emission Mode>

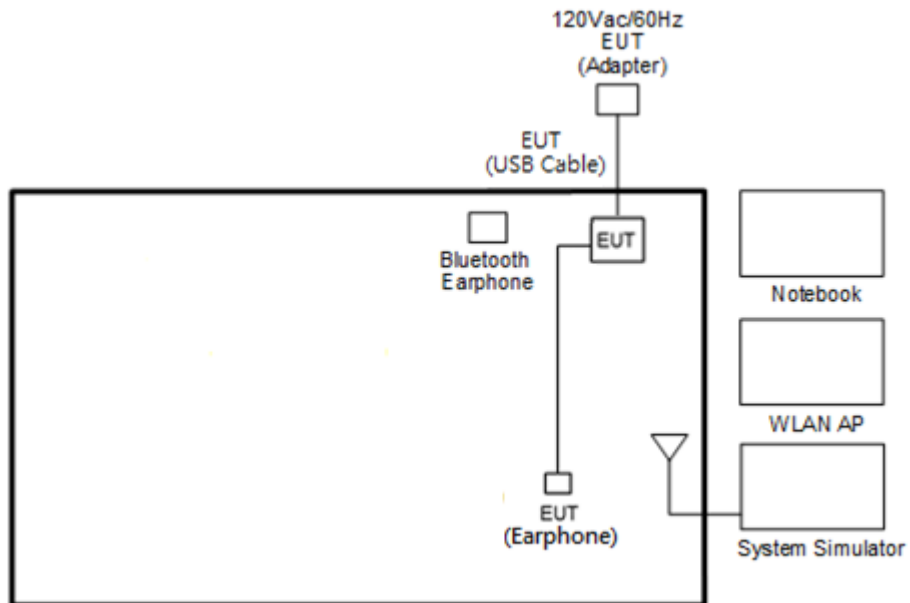



2.4 Support Unit used in test configuration and system

Item	Equipment	Trade Name	Model Name	FCC ID	Data Cable	Power Cord
1.	System Simulator	Anritsu	MT8820C	N/A	N/A	Unshielded, 1.8 m
2.	Bluetooth Earphone	Sony Ericsson	MW600	PY7DDA-2029	N/A	N/A
3.	WLAN AP	ASUS	RT-AC66U	MSQ-RTAC66U	N/A	Unshielded, 1.8 m
4.	Notebook	DELL	Latitude E6320	FCC DoC/ Contains FCC ID: QDS-BRCM1054	N/A	AC I/P: Unshielded, 1.2 m DC O/P: Shielded, 1.8 m
5.	SD Card	SanDisk	MicroSD HC	FCC DoC	N/A	N/A

2.5 EUT Operation Test Setup

The RF test items, utility "QDART_WIN_4_8_Installer_00064_1 qpst.win.2.7_installer_00471.4" was installed in Notebook which was programmed in order to make the EUT get into the engineering modes to provide channel selection, power level, data rate and the application type and for continuous transmitting signals.

2.6 Measurement Results Explanation Example

For all conducted test items:

The offset level is set in the spectrum analyzer to compensate the RF cable loss and attenuator factor between EUT conducted output port and spectrum analyzer. With the offset compensation, the spectrum analyzer reading level is exactly the EUT RF output level.

Example :

The spectrum analyzer offset is derived from RF cable loss and attenuator factor.

Offset = RF cable loss + attenuator factor.

Following shows an offset computation example with cable loss 4.2 dB and 10dB attenuator.

$$\begin{aligned} \text{Offset(dB)} &= \text{RF cable loss(dB)} + \text{attenuator factor(dB)}. \\ &= 4.2 + 10 = 14.2 \text{ (dB)} \end{aligned}$$

3 Test Result

3.1 26dB & 99% Occupied Bandwidth Measurement

3.1.1 Description of 26dB & 99% Occupied Bandwidth

This section is for reporting purpose only.

There is no restriction limits for bandwidth.

3.1.2 Measuring Instruments

See list of measuring equipment of this test report.

3.1.3 Test Procedures

1. The testing follows FCC KDB 789033 D02 General UNII Test Procedures New Rules v02r01. Section C) Emission bandwidth
2. Set RBW = approximately 1% of the emission bandwidth.
3. Set the VBW > RBW.
4. Detector = Peak.
5. Trace mode = max hold
6. Measure the maximum width of the emission that is 26 dB down from the peak of the emission. Compare this with the RBW setting of the analyzer. Readjust RBW and repeat measurement as needed until the RBW/EBW ratio is approximately 1%.
7. For 99% Bandwidth Measurement, the spectrum analyzer's resolution bandwidth (RBW) is set 1-5% of the emission bandwidth and set the Video bandwidth (VBW) $\geq 3 * RBW$.
8. Measure and record the results in the test report.

3.1.4 Test Setup

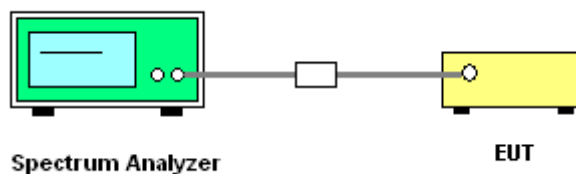



3.1.5 Test Result of 26dB & 99% Occupied Bandwidth

Please refer to Appendix A

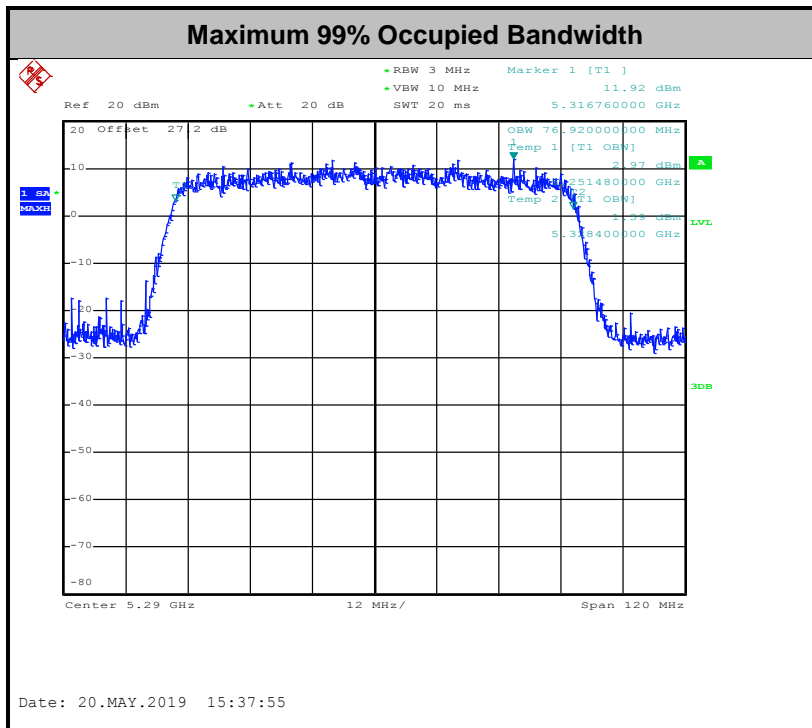
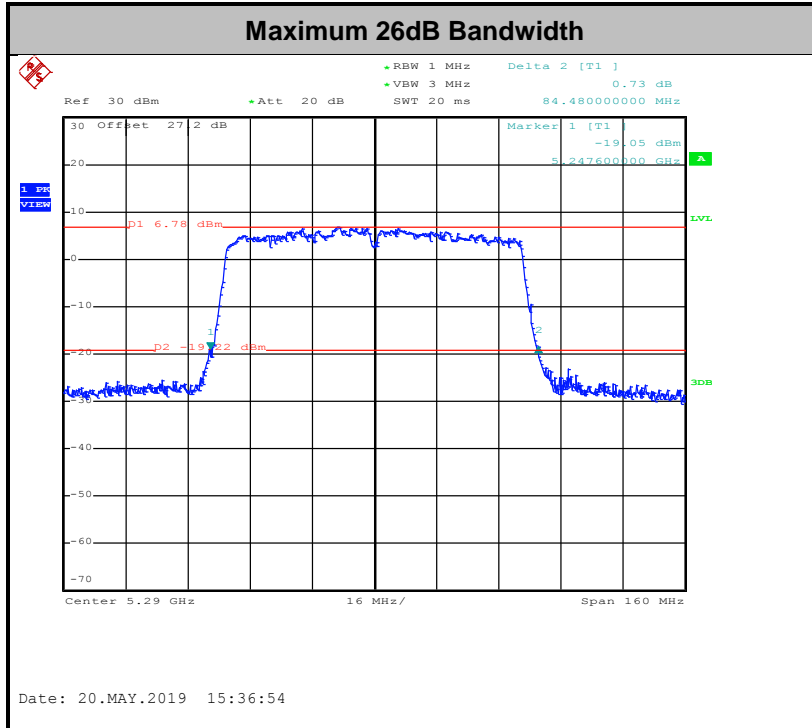

Note: The occupied channel bandwidth is maintained within the band of operation for all of the modulations.



3.2 Maximum Conducted Output Power Measurement

3.2.1 Limit of Maximum Conducted Output Power

<FCC 14-30 CFR 15.407>

For the 5.15–5.25 GHz bands:

- For mobile and portable client devices in the 5.15–5.25 GHz band, the maximum conducted output power over the frequency band of operation shall not exceed 250 mW. For an indoor access point operating in the band 5.15-5.25 GHz, the maximum conducted output power over the frequency band of operation shall not exceed 1 W.

For the 5.25–5.725 GHz bands:

- The maximum conducted output power over the frequency bands of operation shall not exceed the lesser of 250 mW or $11 \text{ dBm} + 10 \log B$, where B is the 26 dB emission bandwidth in megahertz.

If transmitting antennas of directional gain greater than 6 dBi are used, the peak output power shall be reduced by the amount in dB that the directional gain of the antenna exceeds 6 dBi.

Note that U-NII-2 band, devices with a maximum e.i.r.p. greater than 500 mW shall implement TPC in order to have the capability to operate at least 6 dB below the maximum permitted e.i.r.p. of 1 W.

3.2.2 Measuring Instruments

See list of measuring equipment of this test report.

3.2.3 Test Procedures

The testing follows Method PM-G of FCC KDB 789033 D02 General UNII Test Procedures New Rules v02r01.

Method PM-G (Measurement using a gated RF average power meter):

1. Measurement is performed using a wideband RF power meter.
2. The EUT is configured to transmit at its maximum power control level.
3. Measure the average power of the transmitter
4. Since the measurement is made only during the ON time of the transmitter, no duty cycle correction factor is required.

3.2.4 Test Setup

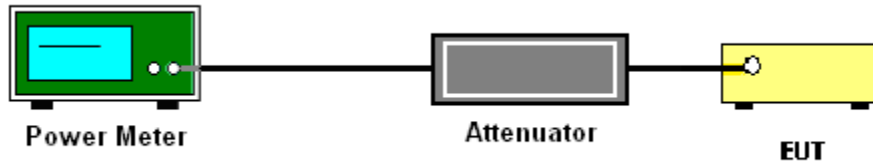

3.2.5 Test Result of Maximum Conducted Output Power

Please refer to Appendix A.



3.3 Power Spectral Density Measurement

3.3.1 Limit of Power Spectral Density

<FCC 14-30 CFR 15.407>

For the 5.15–5.25 GHz bands:

For mobile and portable client devices in the 5.15–5.25 GHz band, the maximum power spectral density shall not exceed 11 dBm in any 1.0 MHz band. For an indoor access point operating in the band 5.15-5.25 GHz, the maximum power spectral density shall not exceed 17 dBm in any 1.0 MHz band.

For the 5.25–5.725 GHz bands:

The maximum power spectral density shall not exceed 11 dBm in any 1.0 MHz band.

If transmitting antennas of directional gain greater than 6 dBi are used, the peak output power shall be reduced by the amount in dB that the directional gain of the antenna exceeds 6 dBi.

3.3.2 Measuring Instruments

See list of measuring equipment of this test report.

3.3.3 Test Procedures

The testing follows FCC KDB 789033 D02 General UNII Test Procedures New Rules v02r01. Section F) Maximum power spectral density.

Method SA-2

(trace averaging across on and off times of the EUT transmissions, followed by duty cycle correction).

- Measure the duty cycle.
 - Set span to encompass the entire emission bandwidth (EBW) of the signal.
 - Set RBW = 1 MHz.
 - Set VBW \geq 3 MHz.
 - Number of points in sweep \geq 2 Span / RBW.
 - Sweep time = auto.
 - Detector = RMS
 - Trace average at least 100 traces in power averaging mode.
 - Add $10 \log(1/x)$, where x is the duty cycle, to the measured power in order to compute the average power during the actual transmission times. For example, add $10 \log(1/0.25) = 6$ dB if the duty cycle is 25 percent.
1. The RF output of EUT was connected to the spectrum analyzer by a low loss cable.
 2. Each plot has already offset with cable loss, and attenuator loss. Measure the PPSD and record it.



3.4 Unwanted Emissions Measurement

This section is to measure unwanted emissions through radiated measurement for band edge spurious emissions and out of band emissions measurement.

3.4.1 Limit of Unwanted Emissions

- (1) For transmitters operating in the 5150-5250 MHz band: all emissions outside of the 5150-5350 MHz band shall not exceed an EIRP of -27dBm/MHz.

For transmitters operating in the 5250-5350 MHz band: all emissions outside of the 5150-5350 MHz band shall not exceed an EIRP of -27 dBm/MHz. Devices operating in the 5250-5350 MHz band that generate emissions in the 5150-5250 MHz band must meet all applicable technical requirements for operation in the 5150-5250 MHz band (including indoor use) or alternatively meet an out-of-band emission EIRP limit of -27 dBm/MHz in the 5150-5250 MHz band.

For transmitters operating in the 5470-5600 MHz and 5650-5725MHz band: all emissions outside of the 5470-5600 MHz and 5650-5725MHz band shall not exceed an EIRP of -27 dBm/MHz.

- (2) Unwanted spurious emissions fallen in restricted bands shall comply with the general field strength limits as below table:

Frequency (MHz)	Field Strength (microvolts/meter)	Measurement Distance (meters)
0.009 – 0.490	2400/F(kHz)	300
0.490 – 1.705	24000/F(kHz)	30
1.705 – 30.0	30	30
30 – 88	100	3
88 – 216	150	3
216 - 960	200	3
Above 960	500	3

Note: The following formula is used to convert the EIRP to field strength.

$$E = \frac{1000000\sqrt{30P}}{3} \text{ } \mu\text{V/m, where P is the eirp (Watts)}$$



EIRP (dBm)	Field Strength at 3m (dBµV/m)
- 27	68.3

(3) KDB789033 D02 v02r01 G)2)c)

- (i) Section 15.407(b)(1) to (b)(3) specify the unwanted emission limits for the U-NII-1 and U-NII-2 bands. As specified, emissions above 1000 MHz that are outside of the restricted bands are subject to a peak emission limit of -27 dBm/MHz.³
- (ii) Section 15.407(b)(4) specifies the unwanted emission limit for the U-NII-3 band. A band emissions mask is specified in Section 15.407(b)(4)(i). The emission limits are in terms of a Peak detector. An alternative to the band emissions mask is specified in Section 15.407(b)(4)(ii). The alternative limits are based on the highest antenna gain specified in the filing. There are also marketing and importation restrictions for the devices using the alternative limit.⁴

Note 3: An out-of-band emission that complies with both the average and peak limits of Section 15.209 is not required to satisfy the -27 dBm/MHz peak emission limit.

Note 4: Only devices with antenna gains of 10 dBi or less may be approved using the emission limits specified in Section 15.247(d) till March 2, 2018; all other devices operating in this band must use the mask specified in Section 15.407(b)(4)(i).

3.4.2 Measuring Instruments

See list of measuring equipment of this test report.

3.4.3 Test Procedures

1. The testing follows FCC KDB 789033 D02 General UNII Test Procedures New Rules v02r01. Section G) Unwanted emissions measurement.
 - (1) Procedure for Unwanted Emissions Measurements Below 1000MHz
 - RBW = 120 kHz
 - VBW = 300 kHz
 - Detector = Peak
 - Trace mode = max hold
 - (2) Procedure for Peak Unwanted Emissions Measurements Above 1000 MHz
 - RBW = 1 MHz
 - VBW ≥ 3 MHz
 - Detector = Peak
 - Sweep time = auto
 - Trace mode = max hold



(3) Procedures for Average Unwanted Emissions Measurements Above 1000MHz

- RBW = 1 MHz
 - VBW = 10 Hz, when duty cycle is no less than 98 percent.
 - $VBW \geq 1/T$, when duty cycle is less than 98 percent where T is the minimum transmission duration over which the transmitter is on and is transmitting at its maximum power control level for the tested mode of operation.
2. The EUT was placed on a turntable with 0.8 meter for frequency below 1GHz and 1.5 meter for frequency above 1GHz respectively above ground.
 3. The EUT was set 3 meters from the interference receiving antenna which was mounted on the top of a variable height antenna tower.
 4. The antenna is a broadband antenna and its height is adjusted between one meter and four meters above ground to find the maximum value of the field strength for both horizontal polarization and vertical polarization of the antenna.
 5. For each suspected emission, the EUT was arranged to its worst case and then adjust the antenna tower (from 1 m to 4 m) and turntable (from 0 degree to 360 degrees) to find the maximum reading.
 6. For testing below 1GHz, if the emission level of the EUT in peak mode was 3 dB lower than the limit specified, then peak values of EUT will be reported, otherwise, the emissions will be repeated one by one using the CISPR quasi-peak method and reported.
 7. For testing above 1GHz, the emission level of the EUT in peak mode was 20dB lower than average limit (that means the emission level in average mode also complies with the limit in average mode), then peak values of EUT will be reported, otherwise, the emissions will be measured in average mode again and reported.

3.4.4 Test Setup

For radiated emissions below 30MHz

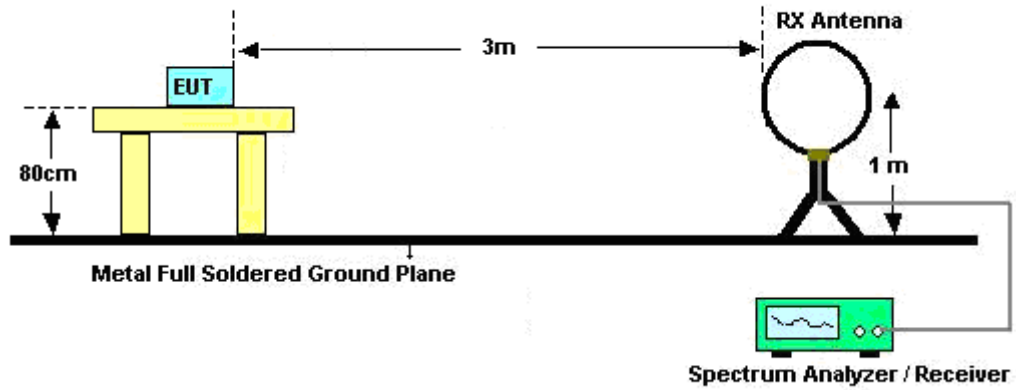

For radiated emissions from 30MHz to 1GHz

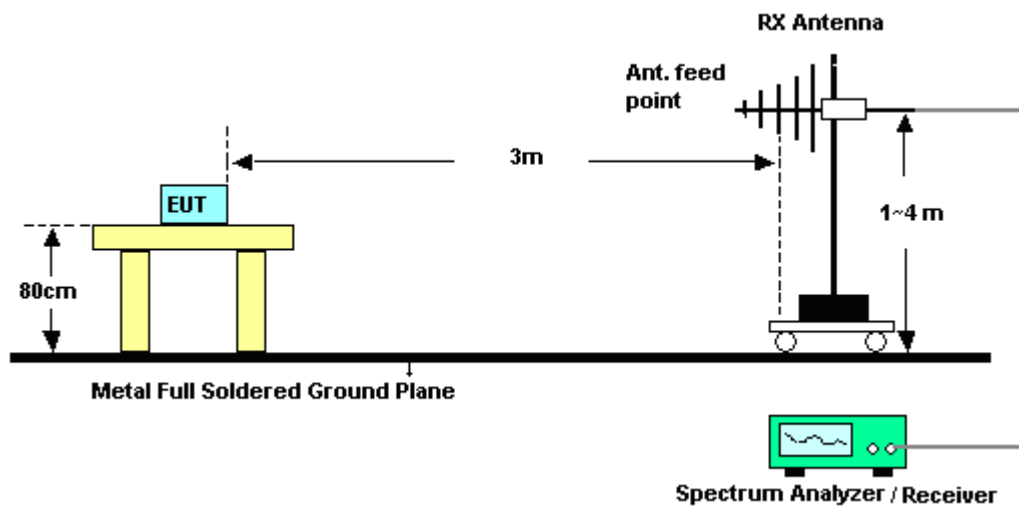

For radiated emissions above 1GHz

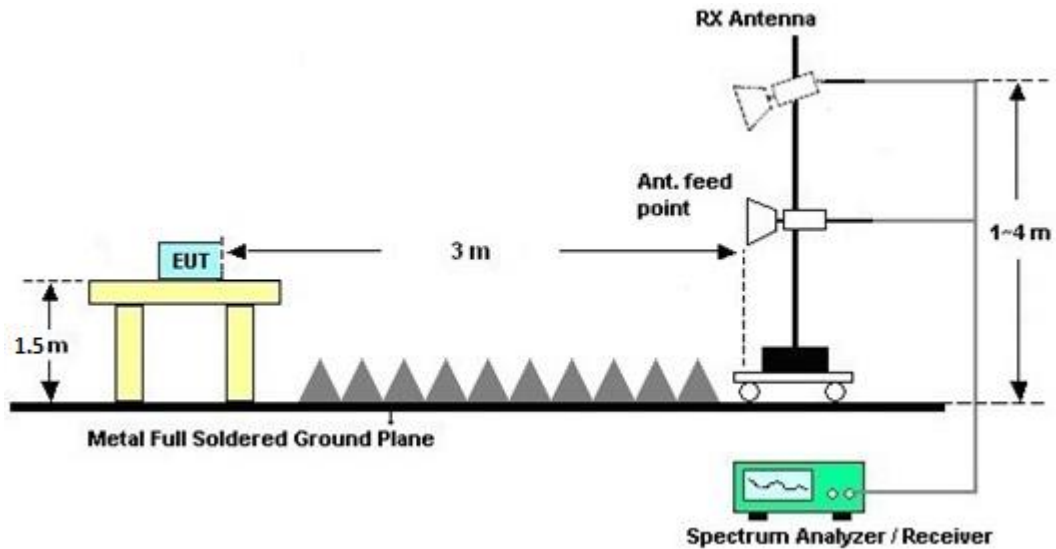

3.4.5 Test Results of Radiated Spurious Emissions (9 kHz ~ 30 MHz)

The low frequency, which started from 9 kHz to 30MHz, was pre-scanned and the result which was 20dB lower than the limit line was not reported.

There is a comparison data of both open-field test site and alternative test site - semi-Anechoic chamber according to 414788 D01 Radiated Test Site v01r01, and the result came out very similar.

3.4.6 Test Result of Radiated Spurious at Band Edges

Please refer to Appendix C and D.

3.4.7 Duty Cycle

Please refer to Appendix E.

3.4.8 Test Result of Radiated Spurious Emissions (30MHz ~ 10th Harmonic)

Please refer to Appendix C and D.



3.5 AC Conducted Emission Measurement

3.5.1 Limit of AC Conducted Emission

For equipment that is designed to be connected to the public utility (AC) power line, the radio frequency voltage that is conducted back onto the AC power line on any frequency or frequencies within the band 150 kHz to 30 MHz shall not exceed the limits in the following table.

Frequency of emission (MHz)	Conducted limit (dB μ V)	
	Quasi-peak	Average
0.15-0.5	66 to 56*	56 to 46*
0.5-5	56	46
5-30	60	50

*Decreases with the logarithm of the frequency.

3.5.2 Measuring Instruments

See list of measuring equipment of this test report.

3.5.3 Test Procedures

1. The EUT was placed 0.4 meter from the conducting wall of the shielding room was kept at least 80 centimeters from any other grounded conducting surface.
2. Connect EUT to the power mains through a line impedance stabilization network (LISN).
3. All the support units are connecting to the other LISN.
4. The LISN provides 50 ohm coupling impedance for the measuring instrument.
5. The FCC states that a 50 ohm, 50 microhenry LISN should be used.
6. Both sides of AC line were checked for maximum conducted interference.
7. The frequency range from 150 kHz to 30 MHz was searched.
8. Set the test-receiver system to Peak Detect Function and specified bandwidth with Maximum Hold Mode.

3.5.4 Test Setup

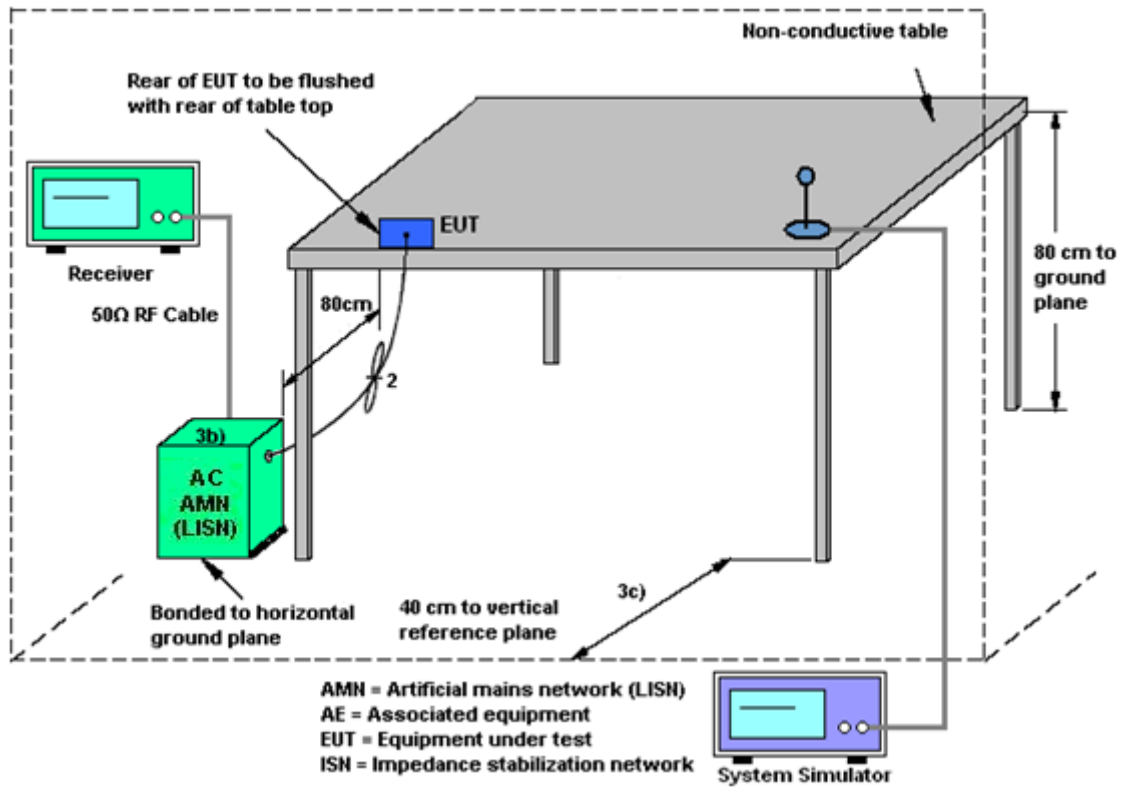

3.5.5 Test Result of AC Conducted Emission

Please refer to Appendix B.



3.6 Automatically Discontinue Transmission

3.6.1 Limit of Automatically Discontinue Transmission

The device shall automatically discontinue transmission in case of either absence of information to transmit or operational failure. These provisions are not intended to preclude the transmission of control or signaling information or the use of repetitive codes used by certain digital technologies to complete frame or burst intervals. Applicants shall include in their application for equipment authorization to describe how this requirement is met.

3.6.2 Measuring Instruments

See list of measuring equipment of this test report.

3.6.3 Test Result of Automatically Discontinue Transmission

While the EUT is not transmitting any information, the EUT can automatically discontinue transmission and become standby mode for power saving. The EUT can detect the controlling signal of ACK message transmitting from remote device and verify whether it shall resend or discontinue transmission.



3.7 Antenna Requirements

3.7.1 Standard Applicable

If transmitting antenna directional gain is greater than 6 dBi, both the peak transmit power and the peak power spectral density shall be reduced by the amount in dB that the directional gain of the antenna exceeds 6 dBi.

3.7.2 Antenna Anti-Replacement Construction

An embedded-in antenna design is used.

3.7.3 Antenna Gain

The antenna peak gain of EUT is less than 6 dBi. Therefore, it is not necessary to reduce maximum peak output power limit.



4 List of Measuring Equipment

Instrument	Manufacturer	Model No.	Serial No.	Characteristics	Calibration Date	Test Date	Due Date	Remark
Hygrometer	Testo	DTM-303A	TP157075	N/A	Nov. 05, 2018	May 07, 2019~ May 20, 2019	Nov. 04, 2019	Conducted (TH05-HY)
Power Sensor	DARE	RPR3006W	13I00030S NO32	9kHz~6GHz	Dec. 03, 2018	May 07,2019~ May 20,2019	Dec. 02, 2019	Conducted (TH05-HY)
Spectrum Analyzer	Rohde & Schwarz	FSP40	100057	9kHz-40GHz	Nov. 21, 2018	May 07,2019~ May 20,2019	Nov. 20, 2019	Conducted (TH05-HY)
Switch Box & RF Cable	Burgeon	ETF-058	EC120838 2	N/A	Mar. 27, 2019	May 07,2019~ May 20,2019	Mar. 26, 2020	Conducted (TH05-HY)
AC Power Source	ChainTek	APC-1000W	N/A	N/A	N/A	May. 27, 2019	N/A	Conduction (CO05-HY)
EMI Test Receiver	Rohde & Schwarz	ESR3	102388	9KHz~3.6GHz	Nov. 12, 2018	May. 27, 2019	Nov. 11, 2019	Conduction (CO05-HY)
Hygrometer	Testo	608-H1	34913912	N/A	Mar. 19, 2019	May 27, 2019	Mar. 18, 2020	Conduction (CO05-HY)
LISN	Rohde & Schwarz	ENV216	100080	9kHz~30MHz	Nov. 14, 2018	May. 27, 2019	Nov. 13, 2019	Conduction (CO05-HY)
LISN	Rohde & Schwarz	ENV216	100081	9kHz~30MHz	Nov. 09, 2018	May. 27, 2019	Nov. 08, 2019	Conduction (CO05-HY)
Software	Rohde & Schwarz	EMC32 V10.30	N/A	N/A	N/A	May. 27, 2019	N/A	Conduction (CO05-HY)
LF Cable	HUBER + SUHNER	RG-214/U	LF01	N/A	Dec. 31, 2018	May. 27, 2019	Dec. 30, 2019	Conduction (CO05-HY)
Pulse Limiter	Rohde & Schwarz	ESH3-Z2	100851	N/A	Dec. 31, 2018	May. 27, 2019	Dec. 30, 2019	Conduction (CO05-HY)
Loop Antenna	Rohde & Schwarz	HFH2-Z2	100488	9 kHz~30 MHz	Jan. 07, 2019	May 09, 2019~ May 12, 2019	Jan. 06, 2020	Radiation (03CH15-HY)
Preamplifier	EMEC	EM18G40G	060715	18GHz~ 40GHz	Dec. 06, 2018	May 09, 2019~ May 12, 2019	Dec. 05, 2019	Radiation (03CH15-HY)
Bilog Antenna	TESEQ	CBL6111D&0 0800N1D01N- 06	41912&05	30MHz to 1GHz	Feb. 12, 2019	May 09, 2019~ May 12, 2019	Feb. 11, 2020	Radiation (03CH15-HY)
Horn Antenna	SCHWARZBE CK	BBHA 9120D	9120D-162 0	1G~18GHz	Oct. 17, 2018	May 09, 2019~ May 12, 2019	Oct. 16, 2019	Radiation (03CH15-HY)
SHF-EHF Horn Antenna	SCHWARZBE CK	BBHA 9170	BBHA9170 584	18GHz- 40GHz	Dec. 05, 2018	May 09, 2019~ May 12, 2019	Dec. 04, 2019	Radiation (03CH15-HY)
Amplifier	SONOMA	310N	363440	9kHz~1GHz	Dec. 28, 2018	May 09, 2019~ May 12, 2019	Dec. 27, 2019	Radiation (03CH15-HY)
Preamplifier	Jet-Power	JAP00101800 -30-10P	160118550 004	1GHz~18GHz	Apr. 16, 2019	May 09, 2019~ May 12, 2019	Apr. 15, 2020	Radiation (03CH15-HY)
Preamplifier	Keysight	83017A	MY532700 78	1GHz~26.5GHz	Oct. 28, 2018	May 09, 2019~ May 12, 2019	Oct. 27, 2019	Radiation (03CH15-HY)
EMI Test Receiver	Keysight	N9038A (MXE)	MY541300 85	20Hz ~ 8.4GHz	Nov. 01, 2018	May 09, 2019~ May 12, 2019	Oct. 31, 2019	Radiation (03CH15-HY)
Spectrum Analyzer	Agilent	E4446A	MY501801 36	3Hz~44GHz	Apr. 30, 2019	May 09, 2019~ May 12, 2019	Apr. 29, 2020	Radiation (03CH15-HY)



Instrument	Manufacturer	Model No.	Serial No.	Characteristics	Calibration Date	Test Date	Due Date	Remark
Controller	ChainTek	3000-1	N/A	Control Turn table & Ant Mast	N/A	May 09, 2019~ May 12, 2019	N/A	Radiation (03CH15-HY)
Antenna Mast	ChainTek	MBS-520-1	N/A	1m~4m	N/A	May 09, 2019~ May 12, 2019	N/A	Radiation (03CH15-HY)
Turn Table	ChainTek	T-200-S-1	N/A	0~360 Degree	N/A	May 09, 2019~ May 12, 2019	N/A	Radiation (03CH15-HY)
Software	Audix	E3 6.2009-8-24	RK-00045 1	N/A	N/A	May 09, 2019~ May 12, 2019	N/A	Radiation (03CH15-HY)
RF Cable	HUBER + SUHNER	SUCOFLEX 104	MY36980/ 4	30M-18G	Apr. 15, 2019	May 09, 2019~ May 12, 2019	Apr. 14, 2020	Radiation (03CH15-HY)
RF Cable	HUBER + SUHNER	SUCOFLEX 104	MY9838/4	30M-18G	Apr. 15, 2019	May 09, 2019~ May 12, 2019	Apr. 14, 2020	Radiation (03CH15-HY)
RF Cable	HUBER + SUHNER	MTJ	000000-M T18A-100 D3210	30M-18G	Apr. 15, 2019	May 09, 2019~ May 12, 2019	Apr. 14, 2020	Radiation (03CH15-HY)
RF Cable	HUBER + SUHNER	SUCOFLEX 102	MY2859/2	30MHz-40GHz	Mar. 13, 2019	May 09, 2019~ May 12, 2019	Mar. 12, 2020	Radiation (03CH15-HY)
RF Cable	HUBER + SUHNER	SUCOFLEX 102	MY4274/2	30MHz-40GHz	Mar. 13, 2019	May 09, 2019~ May 12, 2019	Mar. 12, 2020	Radiation (03CH15-HY)
Filter	Wainwright	WHKX8-5872. 5-6750-18000 -40ST	SN3	6.75 GHz Highpass	Sep. 16, 2018	May 09, 2019~ May 12, 2019	Sep. 15, 2019	Radiation (03CH15-HY)
Filter	Wainwright	WLK4-1000-1 530-8000-40S S	SN11	1G Low Pass	Sep. 16, 2018	May 09, 2019~ May 12, 2019	Sep. 15, 2019	Radiation (03CH15-HY)
Hygrometer	TECPEL	DTM-303B	TP140320	N/A	Nov. 05, 2018	May 09, 2019~ May 12, 2019	Nov. 04, 2019	Radiation (03CH15-HY)



5 Uncertainty of Evaluation

Uncertainty of Conducted Emission Measurement (150kHz ~ 30MHz)

Measuring Uncertainty for a Level of Confidence of 95% ($U = 2Uc(y)$)	2.20
---	------

Uncertainty of Radiated Emission Measurement (30 MHz ~ 1000 MHz)

Measuring Uncertainty for a Level of Confidence of 95% ($U = 2Uc(y)$)	5.20
---	------

Uncertainty of Radiated Emission Measurement (1000 MHz ~ 18000 MHz)

Measuring Uncertainty for a Level of Confidence of 95% ($U = 2Uc(y)$)	5.50
---	------

Uncertainty of Radiated Emission Measurement (18000 MHz ~ 40000 MHz)

Measuring Uncertainty for a Level of Confidence of 95% ($U = 2Uc(y)$)	5.20
---	------

Appendix A. Test Result of Conducted Test Items

Test Engineer:	Rebecca Li	Temperature:	21~25	°C
Test Date:	2019/05/07 ~ 2019/05/20	Relative Humidity:	51~54	%

TEST RESULTS DATA
26dB and 99% OBW

Band I													
Mod.	Data Rate	NTX	CH.	Freq. (MHz)	99% Bandwidth (MHz)		26 dB Bandwidth (MHz)		IC 99% Bandwidth Power Limit (dBm)		IC 99% Bandwidth EIRP Limit (dBm)		Note
					Ant 1	Ant 2	Ant 1	Ant 2	Ant 1	Ant 2	Ant 1	Ant 2	
11a	6Mbps	1	36	5180	16.75	-	24.50	-	-	-	22.24	-	
11a	6Mbps	1	44	5220	16.75	-	24.60	-	-	-	22.24	-	
11a	6Mbps	1	48	5240	16.70	-	24.80	-	-	-	22.23	-	
HT20	MCS0	1	36	5180	17.90	-	25.50	-	-	-	22.53	-	
HT20	MCS0	1	44	5220	17.90	-	26.30	-	-	-	22.53	-	
HT20	MCS0	1	48	5240	17.85	-	25.70	-	-	-	22.52	-	
HT40	MCS0	1	38	5190	36.60	-	41.94	-	-	-	23.01	-	
HT40	MCS0	1	46	5230	36.60	-	41.76	-	-	-	23.01	-	
VHT80	MCS0	1	42	5210	76.80	-	83.84	-	-	-	23.01	-	

TEST RESULTS DATA
Average Power Table

FCC Band I												
Mod.	Data Rate	NTX	CH.	Freq. (MHz)	Average Conducted Power (dBm)			FCC Conducted Power Limit (dBm)		DG (dBi)		Pass/Fail
					Ant 1	Ant 2	SUM	Ant 1	Ant 2	Ant 1	Ant 2	
11a	6Mbps	1	36	5180	16.60	-		24.00	-	-8.00	-	Pass
11a	6Mbps	1	44	5220	16.70	-		24.00	-	-8.00	-	Pass
11a	6Mbps	1	48	5240	16.70	-		24.00	-	-8.00	-	Pass
HT20	MCS0	1	36	5180	15.50	-		24.00	-	-8.00	-	Pass
HT20	MCS0	1	44	5220	15.70	-		24.00	-	-8.00	-	Pass
HT20	MCS0	1	48	5240	15.50	-		24.00	-	-8.00	-	Pass
HT40	MCS0	1	38	5190	15.10	-		24.00	-	-8.00	-	Pass
HT40	MCS0	1	46	5230	15.60	-		24.00	-	-8.00	-	Pass
VHT20	MCS0	1	36	5180	14.60	-		24.00	-	-8.00	-	Pass
VHT20	MCS0	1	44	5220	14.70	-		24.00	-	-8.00	-	Pass
VHT20	MCS0	1	48	5240	14.60	-		24.00	-	-8.00	-	Pass
VHT40	MCS0	1	38	5190	14.50	-		24.00	-	-8.00	-	Pass
VHT40	MCS0	1	46	5230	14.60	-		24.00	-	-8.00	-	Pass
VHT80	MCS0	1	42	5210	14.60	-		24.00	-	-8.00	-	Pass

TEST RESULTS DATA
Power Spectral Density

FCC Band I														
Mod.	Data Rate	NTX	CH.	Freq. (MHz)	Duty Factor (dB)		Average Power Density (dBm/MHz)			Average PSD Limit (dBm/MHz)		DG (dBi)		Pass /Fail
					Ant 1	Ant 2	Ant 1	Ant 2	SUM	Ant 1	Ant 2	Ant 1	Ant 2	
11a	6Mbps	1	36	5180	0.08	-	6.16	-		11.00	-	-8.00	-	Pass
11a	6Mbps	1	44	5220	0.08	-	6.35	-		11.00	-	-8.00	-	Pass
11a	6Mbps	1	48	5240	0.08	-	6.17	-		11.00	-	-8.00	-	Pass
HT20	MCS0	1	36	5180	0.11	-	4.70	-		11.00	-	-8.00	-	Pass
HT20	MCS0	1	44	5220	0.11	-	4.96	-		11.00	-	-8.00	-	Pass
HT20	MCS0	1	48	5240	0.11	-	4.65	-		11.00	-	-8.00	-	Pass
HT40	MCS0	1	38	5190	0.17	-	1.45	-		11.00	-	-8.00	-	Pass
HT40	MCS0	1	46	5230	0.17	-	1.97	-		11.00	-	-8.00	-	Pass
VHT80	MCS0	1	42	5210	0.36	-	-1.94	-		11.00	-	-8.00	-	Pass

TEST RESULTS DATA
26dB and 99% OBW

Band II															
Mod.	Data Rate	NTX	CH.	Freq. (MHz)	99% Bandwidth (MHz)		26 dB Bandwidth (MHz)		IC 99% Bandwidth Power Limit (dBm)		IC 99% Bandwidth EIRP Limit (dBm)		FCC 26dB Bandwidth Power Limit (dBm)		Note
					Ant 1	Ant 2	Ant 1	Ant 2	Ant 1	Ant 2	Ant 1	Ant 2	Ant 1	Ant 2	
11a	6Mbps	1	52	5260	16.75	-	24.20	-	23.24	-	29.24	-	23.98	-	
11a	6Mbps	1	60	5300	16.75	-	24.50	-	23.24	-	29.24	-	23.98	-	
11a	6Mbps	1	64	5320	16.75	-	24.70	-	23.24	-	29.24	-	23.98	-	
HT20	MCS0	1	52	5260	17.90	-	25.65	-	23.53	-	29.53	-	23.98	-	
HT20	MCS0	1	60	5300	17.95	-	25.80	-	23.54	-	29.54	-	23.98	-	
HT20	MCS0	1	64	5320	17.90	-	25.50	-	23.53	-	29.53	-	23.98	-	
HT40	MCS0	1	54	5270	36.60	-	41.76	-	23.98	-	30.00	-	23.98	-	
HT40	MCS0	1	62	5310	36.60	-	41.94	-	23.98	-	30.00	-	23.98	-	
VHT80	MCS0	1	58	5290	76.92	-	84.48	-	23.98	-	30.00	-	23.98	-	

TEST RESULTS DATA
Average Power Table

FCC Band II													
Mod.	Data Rate	NTX	CH.	Freq. (MHz)	Average Conducted Power (dBm)			FCC Conducted Power Limit (dBm)		DG (dBi)		EIRP Power Limit (dBm)	Pass/Fail
					Ant 1	Ant 2	SUM	Ant 1	Ant 2	Ant 1	Ant 2		
11a	6Mbps	1	52	5260	16.80	-		23.98	-	-8.00	-	26.99	Pass
11a	6Mbps	1	60	5300	16.70	-		23.98	-	-8.00	-	26.99	Pass
11a	6Mbps	1	64	5320	16.60	-		23.98	-	-8.00	-	26.99	Pass
HT20	MCS0	1	52	5260	15.70	-		23.98	-	-8.00	-	26.99	Pass
HT20	MCS0	1	60	5300	15.60	-		23.98	-	-8.00	-	26.99	Pass
HT20	MCS0	1	64	5320	15.70	-		23.98	-	-8.00	-	26.99	Pass
HT40	MCS0	1	54	5270	15.80	-		23.98	-	-8.00	-	26.99	Pass
HT40	MCS0	1	62	5310	15.60	-		23.98	-	-8.00	-	26.99	Pass
VHT20	MCS0	1	52	5260	14.80	-		23.98	-	-8.00	-	26.99	Pass
VHT20	MCS0	1	60	5300	14.60	-		23.98	-	-8.00	-	26.99	Pass
VHT20	MCS0	1	64	5320	14.60	-		23.98	-	-8.00	-	26.99	Pass
VHT40	MCS0	1	54	5270	14.70	-		23.98	-	-8.00	-	26.99	Pass
VHT40	MCS0	1	62	5310	14.60	-		23.98	-	-8.00	-	26.99	Pass
VHT80	MCS0	1	58	5290	14.70	-		23.98	-	-8.00	-	26.99	Pass

TEST RESULTS DATA
Power Spectral Density

Band II														
Mod.	Data Rate	NTX	CH.	Freq. (MHz)	Duty Factor (dB)		Average Power Density (dBm/MHz)			Average PSD Limit (dBm/MHz)		DG (dBi)		Pass /Fail
					Ant 1	Ant 2	Ant 1	Ant 2	SUM	Ant 1	Ant 2	Ant 1	Ant 2	
11a	6Mbps	1	52	5260	0.08	-	6.13	-		11.00	-	-8.00	-	Pass
11a	6Mbps	1	60	5300	0.08	-	5.80	-		11.00	-	-8.00	-	Pass
11a	6Mbps	1	64	5320	0.08	-	5.84	-		11.00	-	-8.00	-	Pass
HT20	MCS0	1	52	5260	0.11	-	4.83	-		11.00	-	-8.00	-	Pass
HT20	MCS0	1	60	5300	0.11	-	4.60	-		11.00	-	-8.00	-	Pass
HT20	MCS0	1	64	5320	0.11	-	4.71	-		11.00	-	-8.00	-	Pass
HT40	MCS0	1	54	5270	0.17	-	1.98	-		11.00	-	-8.00	-	Pass
HT40	MCS0	1	62	5310	0.17	-	1.60	-		11.00	-	-8.00	-	Pass
VHT80	MCS0	1	58	5290	0.36	-	-2.14	-		11.00	-	-8.00	-	Pass

TEST RESULTS DATA
26dB and 99% OBW

Band III																
Mod.	Data Rate	NTX	CH.	Freq. (MHz)	99% Bandwidth In U-NII 2C (MHz)		26 dB Bandwidth In U-NII 2C (MHz)		IC 99% Bandwidth Power Limit (dBm)		IC 99% Bandwidth EIRP Limit (dBm)		FCC 26dB Bandwidth Power Limit (dBm)		6 dB Bandwidth for Straddle Channel (MHz)	
					Ant 1	Ant 2	Ant 1	Ant 2	Ant 1	Ant 2	Ant 1	Ant 2	Ant 1	Ant 2	Ant 1	Ant 2
11a	6Mbps	1	100	5500	16.75	-	24.50	-	23.24	-	29.24	-	23.98	-	----	----
11a	6Mbps	1	116	5580	16.75	-	24.85	-	23.24	-	29.24	-	23.98	-	----	----
11a	6Mbps	1	140	5700	16.80	-	24.90	-	23.25	-	29.25	-	23.98	-	----	----
HT20	MCS0	1	100	5500	17.95	-	26.20	-	23.54	-	29.54	-	23.98	-	----	----
HT20	MCS0	1	116	5580	17.95	-	26.15	-	23.54	-	29.54	-	23.98	-	----	----
HT20	MCS0	1	140	5700	17.95	-	26.25	-	23.54	-	29.54	-	23.98	-	----	----
HT40	MCS0	1	102	5510	36.50	-	42.12	-	23.98	-	30.00	-	23.98	-	----	----
HT40	MCS0	1	110	5550	36.60	-	41.94	-	23.98	-	30.00	-	23.98	-	----	----
HT40	MCS0	1	134	5670	36.50	-	41.76	-	23.98	-	30.00	-	23.98	-	----	----
VHT80	MCS0	1	106	5530	76.80	-	83.84	-	23.98	-	30.00	-	23.98	-	----	----

TEST RESULTS DATA
Average Power Table

FCC Band III													
Mod.	Data Rate	NTX	CH.	Freq. (MHz)	Average Conducted Power (dBm)			FCC Conducted Power Limit (dBm)		DG (dBi)		EIRP Power Limit (dBm)	Pass/Fail
					Ant 1	Ant 2	SUM	Ant 1	Ant 2	Ant 1	Ant 2		
11a	6Mbps	1	100	5500	16.50	-		23.98	-	-8.00	-	26.99	Pass
11a	6Mbps	1	116	5580	16.70	-		23.98	-	-8.00	-	26.99	Pass
11a	6Mbps	1	140	5700	16.50	-		23.98	-	-8.00	-	26.99	Pass
HT20	MCS0	1	100	5500	15.80	-		23.98	-	-8.00	-	26.99	Pass
HT20	MCS0	1	116	5580	15.50	-		23.98	-	-8.00	-	26.99	Pass
HT20	MCS0	1	140	5700	15.80	-		23.98	-	-8.00	-	26.99	Pass
HT40	MCS0	1	102	5510	15.70	-		23.98	-	-8.00	-	26.99	Pass
HT40	MCS0	1	110	5550	15.60	-		23.98	-	-8.00	-	26.99	Pass
HT40	MCS0	1	134	5670	15.80	-		23.98	-	-8.00	-	26.99	Pass
VHT20	MCS0	1	100	5500	14.80	-		23.98	-	-8.00	-	26.99	Pass
VHT20	MCS0	1	116	5580	14.60	-		23.98	-	-8.00	-	26.99	Pass
VHT20	MCS0	1	140	5700	14.70	-		23.98	-	-8.00	-	26.99	Pass
VHT40	MCS0	1	102	5510	14.70	-		23.98	-	-8.00	-	26.99	Pass
VHT40	MCS0	1	110	5550	14.80	-		23.98	-	-8.00	-	26.99	Pass
VHT40	MCS0	1	134	5670	14.70	-		23.98	-	-8.00	-	26.99	Pass
VHT80	MCS0	1	106	5530	14.50	-		23.98	-	-8.00	-	26.99	Pass

TEST RESULTS DATA
Power Spectral Density

Band III														
Mod.	Data Rate	NTX	CH.	Freq. (MHz)	Duty Factor (dB)		Average Power Density (dBm/MHz)			Average PSD Limit (dBm/MHz)		DG (dBi)		Pass /Fail
					Ant 1	Ant 2	Ant 1	Ant 2	SUM	Ant 1	Ant 2	Ant 1	Ant 2	
11a	6Mbps	1	100	5500	0.08	-	5.39	-		11.00	-	-8.00	-	Pass
11a	6Mbps	1	116	5580	0.08	-	5.96	-		11.00	-	-8.00	-	Pass
11a	6Mbps	1	140	5700	0.08	-	5.53	-		11.00	-	-8.00	-	Pass
HT20	MCS0	1	100	5500	0.11	-	4.53	-		11.00	-	-8.00	-	Pass
HT20	MCS0	1	116	5580	0.11	-	4.56	-		11.00	-	-8.00	-	Pass
HT20	MCS0	1	140	5700	0.11	-	4.70	-		11.00	-	-8.00	-	Pass
HT40	MCS0	1	102	5510	0.17	-	1.57	-		11.00	-	-8.00	-	Pass
HT40	MCS0	1	110	5550	0.17	-	1.71	-		11.00	-	-8.00	-	Pass
HT40	MCS0	1	134	5670	0.17	-	1.99	-		11.00	-	-8.00	-	Pass
VHT80	MCS0	1	106	5530	0.36	-	-2.56	-		11.00	-	-8.00	-	Pass



Appendix B. AC Conducted Emission Test Results

Test Engineer :	Eric Jeng and Jimmy Chang	Temperature :	22~25°C
		Relative Humidity :	52~55%

EUT Information

Report NO : 942629
 Test Mode : Mode 1
 Test Voltage : 120Vac/60Hz
 Phase : Line

Full Spectrum

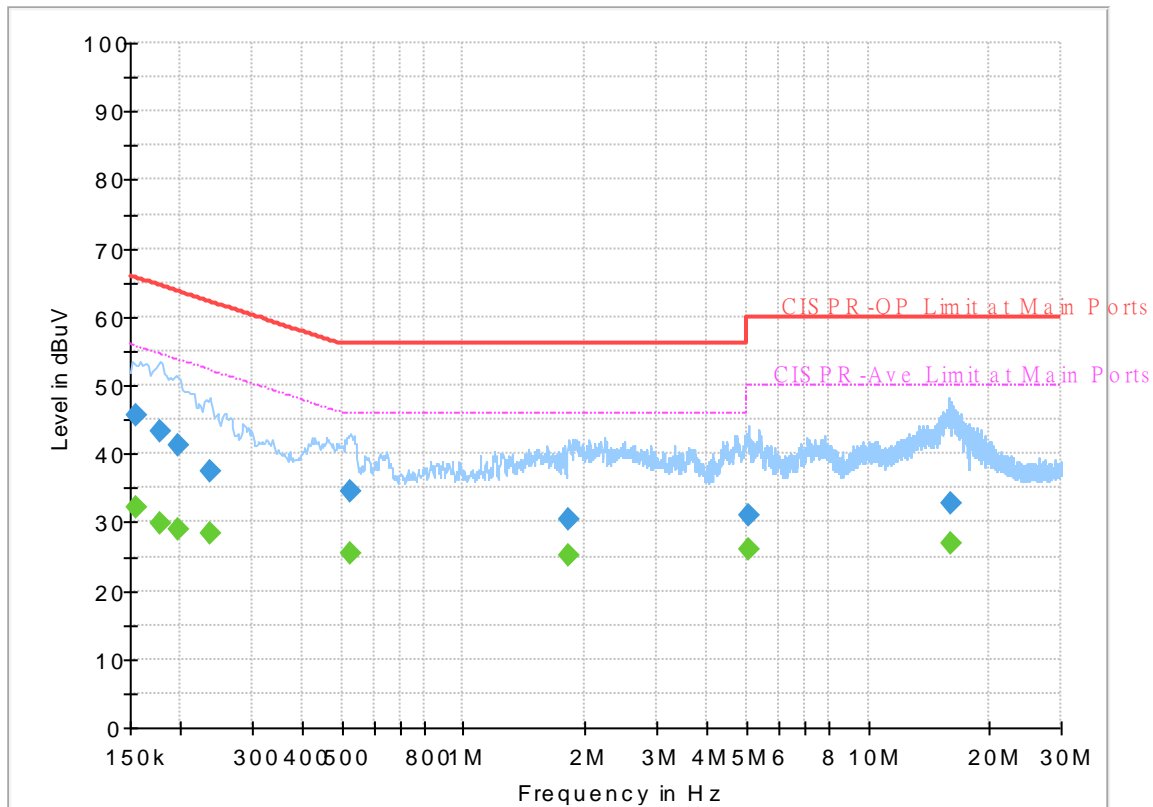

Final_Result

Frequency (MHz)	QuasiPeak (dBuV)	CAverage (dBuV)	Limit (dBuV)	Margin (dB)	Line	Filter	Corr. (dB)
0.154500	---	32.11	55.75	23.64	L1	OFF	19.5
0.154500	45.61	---	65.75	20.14	L1	OFF	19.5
0.177000	---	29.96	54.63	24.67	L1	OFF	19.5
0.177000	43.30	---	64.63	21.33	L1	OFF	19.5
0.197250	---	28.91	53.73	24.82	L1	OFF	19.5
0.197250	41.27	---	63.73	22.46	L1	OFF	19.5
0.235500	---	28.37	52.25	23.88	L1	OFF	19.5
0.235500	37.49	---	62.25	24.76	L1	OFF	19.5
0.528000	---	25.54	46.00	20.46	L1	OFF	19.5
0.528000	34.57	---	56.00	21.43	L1	OFF	19.5
1.828500	---	25.09	46.00	20.91	L1	OFF	19.6
1.828500	30.54	---	56.00	25.46	L1	OFF	19.6
5.061750	---	26.03	50.00	23.97	L1	OFF	19.7
5.061750	30.96	---	60.00	29.04	L1	OFF	19.7
15.972000	---	27.04	50.00	22.96	L1	OFF	20.1
15.972000	32.74	---	60.00	27.26	L1	OFF	20.1

EUT Information

Report NO : 942629
 Test Mode : Mode 1
 Test Voltage : 120Vac/60Hz
 Phase : Neutral

Full Spectrum

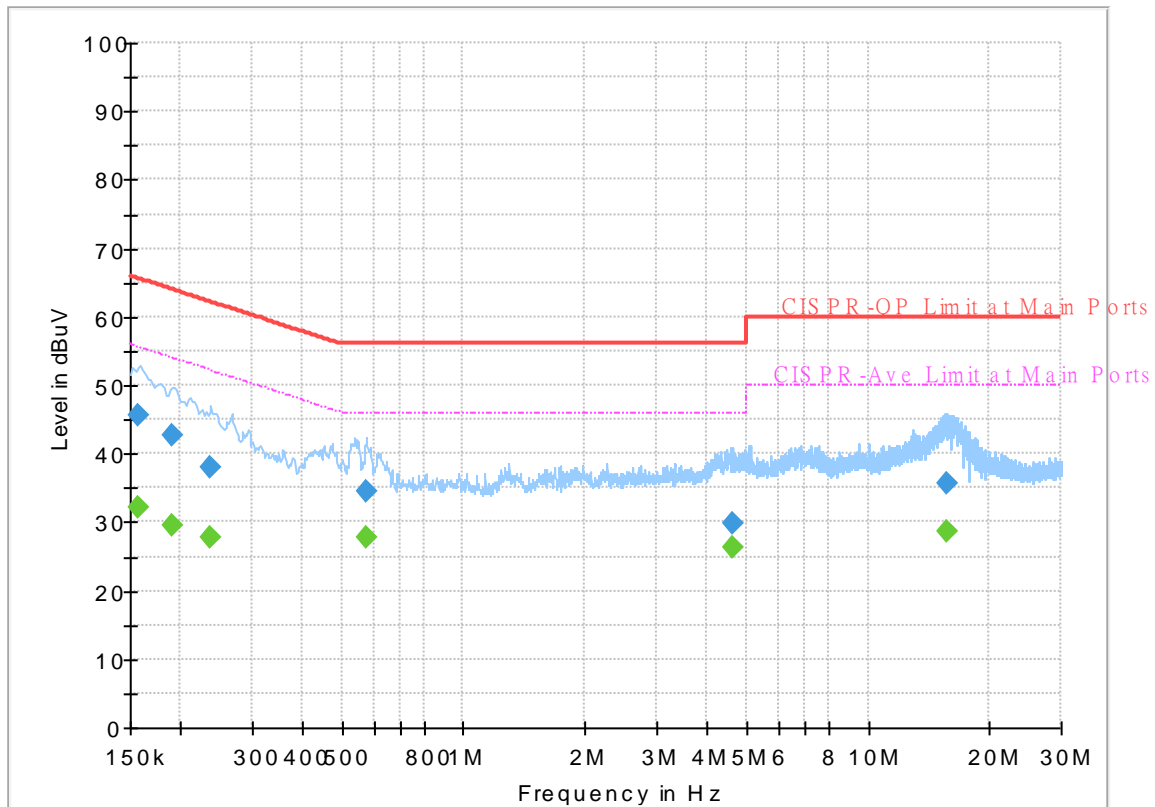

Final Result

Frequency (MHz)	QuasiPeak (dBuV)	CAverage (dBuV)	Limit (dBuV)	Margin (dB)	Line	Filter	Corr. (dB)
0.156750	---	32.08	55.63	23.55	N	OFF	19.5
0.156750	45.49	---	65.63	20.14	N	OFF	19.5
0.190500	---	29.59	54.02	24.43	N	OFF	19.5
0.190500	42.82	---	64.02	21.20	N	OFF	19.5
0.237750	---	27.90	52.17	24.27	N	OFF	19.5
0.237750	37.99	---	62.17	24.18	N	OFF	19.5
0.575250	---	27.80	46.00	18.20	N	OFF	19.5
0.575250	34.62	---	56.00	21.38	N	OFF	19.5
4.641000	---	26.21	46.00	19.79	N	OFF	19.7
4.641000	29.82	---	56.00	26.18	N	OFF	19.7
15.618750	---	28.73	50.00	21.27	N	OFF	20.1
15.618750	35.80	---	60.00	24.20	N	OFF	20.1



Appendix C. Radiated Spurious Emission

Test Engineer :	Watt Tseng, Karl Hou, and BigShow Wang	Temperature :	23~26°C
		Relative Humidity :	50~57%

Band 1 - 5150~5250MHz
WIFI 802.11a (Band Edge @ 3m)

WIFI Ant. 1	Note	Frequency (MHz)	Level (dBμV/m)	Over Limit (dB)	Limit Line (dBμV/m)	Read Level (dBμV)	Antenna Factor (dB/m)	Path Loss (dB)	Preamp Factor (dB)	Ant Pos (cm)	Table Pos (deg)	Peak Avg. (P/A)	Pol. (H/V)	
802.11a CH 36 5180MHz		5142.22	53.04	-20.96	74	41.96	31.8	9.38	30.1	100	86	P	H	
		5150	42.96	-11.04	54	31.87	31.8	9.39	30.1	100	86	A	H	
	*	5180	101.81	-	-	90.83	31.67	9.41	30.1	100	86	P	H	
	*	5180	93.75	-	-	82.77	31.67	9.41	30.1	100	86	A	H	
													H	
														H
			5147.68	50.79	-23.21	74	39.71	31.8	9.38	30.1	324	288	P	V
			5150	42.03	-11.97	54	30.94	31.8	9.39	30.1	324	288	A	V
	*		5180	99.6	-	-	88.62	31.67	9.41	30.1	324	288	P	V
	*		5180	91.88	-	-	80.9	31.67	9.41	30.1	324	288	A	V
														V
														V
802.11a CH 44 5220MHz		5084.24	50.52	-23.48	74	39.38	31.9	9.33	30.09	100	82	P	H	
		5149.24	40.47	-13.53	54	29.39	31.8	9.38	30.1	100	82	A	H	
	*	5220	101.9	-	-	91.03	31.53	9.45	30.11	100	82	P	H	
	*	5220	94.47	-	-	83.6	31.53	9.45	30.11	100	82	A	H	
			5437.04	50.43	-23.57	74	39.19	31.67	9.7	30.13	100	82	P	H
			5456.36	40.45	-13.55	54	29.15	31.7	9.74	30.14	100	82	A	H
			5065.26	50.45	-23.55	74	39.33	31.9	9.31	30.09	338	291	P	V
			5091.52	40.45	-13.55	54	29.31	31.9	9.33	30.09	338	291	A	V
	*		5220	100	-	-	89.13	31.53	9.45	30.11	338	291	P	V
	*		5220	92.49	-	-	81.62	31.53	9.45	30.11	338	291	A	V
			5452.72	51.48	-22.52	74	40.19	31.7	9.73	30.14	338	291	P	V
			5457.48	40.45	-13.55	54	29.15	31.7	9.74	30.14	338	291	A	V



802.11a CH 48 5240MHz		5102.44	50.95	-23.05	74	39.8	31.9	9.34	30.09	100	86	P	H
		5096.98	40.42	-13.58	54	29.27	31.9	9.34	30.09	100	86	A	H
	*	5240	102.06	-	-	91.23	31.47	9.47	30.11	100	86	P	H
	*	5240	95.19	-	-	84.36	31.47	9.47	30.11	100	86	A	H
		5428.64	50.51	-23.49	74	39.28	31.67	9.69	30.13	100	86	P	H
		5459.16	40.41	-13.59	54	29.11	31.7	9.74	30.14	100	86	A	H
		5089.7	50.73	-23.27	74	39.59	31.9	9.33	30.09	336	288	P	V
		5101.14	40.37	-13.63	54	29.22	31.9	9.34	30.09	336	288	A	V
	*	5240	100.34	-	-	89.51	31.47	9.47	30.11	336	288	P	V
	*	5240	92.68	-	-	81.85	31.47	9.47	30.11	336	288	A	V
		5403.16	50.36	-23.64	74	39.24	31.6	9.65	30.13	336	288	P	V
		5460	40.4	-13.6	54	29.1	31.7	9.74	30.14	336	288	A	V
Remark	1. No other spurious found. 2. All results are PASS against Peak and Average limit line.												



Band 1 5150~5250MHz
WIFI 802.11a (Harmonic @ 3m)

WIFI Ant. 1	Note	Frequency (MHz)	Level (dBμV/m)	Over Limit (dB)	Limit Line (dBμV/m)	Read Level (dBμV)	Antenna Factor (dB/m)	Path Loss (dB)	Preamp Factor (dB)	Ant Pos (cm)	Table Pos (deg)	Peak Avg. (P/A)	Pol. (H/V)
802.11a CH 36 5180MHz		10360	47.83	-20.37	68.2	58.5	39.37	13.78	63.82	100	0	P	H
		15540	47.5	-26.5	74	54.7	37.93	17.11	62.24	100	0	P	H
													H
													H
		10360	48.51	-19.69	68.2	59.18	39.37	13.78	63.82	100	0	P	V
		15540	47.26	-26.74	74	54.46	37.93	17.11	62.24	100	0	P	V
													V
													V
802.11a CH 44 5220MHz		10440	46.89	-21.31	68.2	57.21	39.53	13.86	63.71	100	0	P	H
		15660	45.62	-28.38	74	53.24	37.45	17.25	62.32	100	0	P	H
													H
													H
		10440	47.05	-21.15	68.2	57.37	39.53	13.86	63.71	100	0	P	V
		15660	45.59	-28.41	74	53.21	37.45	17.25	62.32	100	0	P	V
													V
													V
802.11a CH 48 5240MHz		10480	47.96	-20.24	68.2	58.15	39.58	13.89	63.66	100	0	P	H
		15720	45.34	-28.66	74	53.1	37.3	17.3	62.36	100	0	P	H
													H
													H
		10480	46.45	-21.75	68.2	56.64	39.58	13.89	63.66	100	0	P	V
		15720	46.59	-27.41	74	54.35	37.3	17.3	62.36	100	0	P	V
													V
													V
Remark	1. No other spurious found. 2. All results are PASS against Peak and Average limit line.												



Band 1 5150~5250MHz
WIFI 802.11n HT20 (Band Edge @ 3m)

WIFI Ant. 1	Note	Frequency (MHz)	Level (dBμV/m)	Over Limit (dB)	Limit Line (dBμV/m)	Read Level (dBμV)	Antenna Factor (dB/m)	Path Loss (dB)	Preamp Factor (dB)	Ant Pos (cm)	Table Pos (deg)	Peak Avg. (P/A)	Pol. (H/V)	
802.11n HT20 CH 36 5180MHz		5071.76	50.19	-23.81	74	39.07	31.9	9.31	30.09	100	87	P	H	
		5150	42.04	-11.96	54	30.95	31.8	9.39	30.1	100	87	A	H	
	*	5180	100.16	-	-	89.18	31.67	9.41	30.1	100	87	P	H	
	*	5180	92.33	-	-	81.35	31.67	9.41	30.1	100	87	A	H	
													H	
														H
			5128.44	51.86	-22.14	74	40.76	31.83	9.37	30.1	311	288	P	V
			5149.76	41.6	-12.4	54	30.52	31.8	9.38	30.1	311	288	A	V
		*	5180	97.79	-	-	86.81	31.67	9.41	30.1	311	288	P	V
		*	5180	90.05	-	-	79.07	31.67	9.41	30.1	311	288	A	V
													V	
													V	
802.11n HT20 CH 44 5220MHz		5067.34	50.62	-23.38	74	39.5	31.9	9.31	30.09	100	151	P	H	
		5102.7	41.27	-12.73	54	30.12	31.9	9.34	30.09	100	151	A	H	
		* 5220	101.26	-	-	90.39	31.53	9.45	30.11	100	151	P	H	
		* 5220	93.67	-	-	82.8	31.53	9.45	30.11	100	151	A	H	
			5430.6	50.72	-23.28	74	39.49	31.67	9.69	30.13	100	151	P	H
			5456.92	41.23	-12.77	54	29.93	31.7	9.74	30.14	100	151	A	H
			5115.96	50.32	-23.68	74	39.19	31.87	9.35	30.09	358	290	P	V
			5101.66	41.52	-12.48	54	30.37	31.9	9.34	30.09	358	290	A	V
		*	5220	98.47	-	-	87.6	31.53	9.45	30.11	358	290	P	V
		*	5220	90.84	-	-	79.97	31.53	9.45	30.11	358	290	A	V
		5361.72	49.99	-24.01	74	39.04	31.47	9.6	30.12	358	290	P	V	
		5433.96	41.15	-12.85	54	29.91	31.67	9.7	30.13	358	290	A	V	



802.11n HT20 CH 48 5240MHz		5089.44	50.78	-23.22	74	39.64	31.9	9.33	30.09	100	150	P	H
		5041.08	41.21	-12.79	54	30.1	31.9	9.29	30.08	100	150	A	H
	*	5240	102.17	-	-	91.34	31.47	9.47	30.11	100	150	P	H
	*	5240	94.11	-	-	83.28	31.47	9.47	30.11	100	150	A	H
		5351.36	50.38	-23.62	74	39.51	31.4	9.59	30.12	100	150	P	H
		5415.48	41.18	-12.82	54	30.01	31.63	9.67	30.13	100	150	A	H
		5072.28	50.27	-23.73	74	39.14	31.9	9.32	30.09	336	291	P	V
		5083.98	41.46	-12.54	54	30.32	31.9	9.33	30.09	336	291	A	V
	*	5240	98.95	-	-	88.12	31.47	9.47	30.11	336	291	P	V
	*	5240	91.4	-	-	80.57	31.47	9.47	30.11	336	291	A	V
		5424.44	50.28	-23.72	74	39.1	31.63	9.68	30.13	336	291	P	V
		5457.48	41.35	-12.65	54	30.05	31.7	9.74	30.14	336	291	A	V
Remark	1. No other spurious found. 2. All results are PASS against Peak and Average limit line.												



Band 1 5150~5250MHz
WIFI 802.11n HT20 (Harmonic @ 3m)

WIFI Ant. 1	Note	Frequency (MHz)	Level (dBμV/m)	Over Limit (dB)	Limit Line (dBμV/m)	Read Level (dBμV)	Antenna Factor (dB/m)	Path Loss (dB)	Preamp Factor (dB)	Ant Pos (cm)	Table Pos (deg)	Peak Avg. (P/A)	Pol. (H/V)	
802.11n HT20 CH 36 5180MHz		10360	45.94	-22.26	68.2	56.61	39.37	13.78	63.82	100	0	P	H	
		15540	45.9	-28.1	74	53.1	37.93	17.11	62.24	100	0	P	H	
													H	
													H	
			10360	46.73	-21.47	68.2	57.4	39.37	13.78	63.82	100	0	P	V
			15540	46.46	-27.54	74	53.66	37.93	17.11	62.24	100	0	P	V
														V
802.11n HT20 CH 44 5220MHz		10440	46.31	-21.89	68.2	56.63	39.53	13.86	63.71	100	0	P	H	
		15660	44.14	-29.86	74	51.76	37.45	17.25	62.32	100	0	P	H	
													H	
													H	
			10440	46.37	-21.83	68.2	56.69	39.53	13.86	63.71	100	0	P	V
			15660	44.62	-29.38	74	52.24	37.45	17.25	62.32	100	0	P	V
														V
802.11n HT20 CH 48 5240MHz		10480	46.56	-21.64	68.2	56.75	39.58	13.89	63.66	100	0	P	H	
		15720	46.48	-27.52	74	54.24	37.3	17.3	62.36	100	0	P	H	
													H	
													H	
			10480	47.33	-20.87	68.2	57.52	39.58	13.89	63.66	100	0	P	V
			15720	49.75	-24.25	74	57.51	37.3	17.3	62.36	100	0	P	V
														V
Remark	1. No other spurious found.													
	2. All results are PASS against Peak and Average limit line.													



**Band 1 5150~5250MHz
WIFI 802.11n HT40 (Band Edge @ 3m)**

WIFI Ant. 1	Note	Frequency (MHz)	Level (dBμV/m)	Over Limit (dB)	Limit Line (dBμV/m)	Read Level (dBμV)	Antenna Factor (dB/m)	Path Loss (dB)	Preamp Factor (dB)	Ant Pos (cm)	Table Pos (deg)	Peak Avg. (P/A)	Pol. (H/V)
802.11n HT40 CH 38 5190MHz		5147.16	55.56	-18.44	74	44.48	31.8	9.38	30.1	100	86	P	H
		5150	49.42	-4.58	54	38.33	31.8	9.39	30.1	100	86	A	H
	*	5190	97.11	-	-	86.12	31.67	9.42	30.1	100	86	P	H
	*	5190	89.19	-	-	78.2	31.67	9.42	30.1	100	86	A	H
		5439.28	50.07	-23.93	74	38.82	31.67	9.71	30.13	100	86	P	H
		5365.36	42	-12	54	31.05	31.47	9.6	30.12	100	86	A	H
		5146.64	53.77	-20.23	74	42.69	31.8	9.38	30.1	365	292	P	V
		5149.76	46.59	-7.41	54	35.51	31.8	9.38	30.1	365	292	A	V
	*	5190	94.86	-	-	83.87	31.67	9.42	30.1	365	292	P	V
	*	5190	87.15	-	-	76.16	31.67	9.42	30.1	365	292	A	V
		5442.64	50.46	-23.54	74	39.21	31.67	9.71	30.13	365	292	P	V
		5431.16	41.87	-12.13	54	30.64	31.67	9.69	30.13	365	292	A	V
	802.11n HT40 CH 46 5230MHz		5056.16	50.72	-23.28	74	39.61	31.9	9.3	30.09	100	148	P
		5048.88	42.11	-11.89	54	31.01	31.9	9.29	30.09	100	148	A	H
*		5230	99.02	-	-	88.2	31.47	9.46	30.11	100	148	P	H
*		5230	91.33	-	-	80.51	31.47	9.46	30.11	100	148	A	H
		5439.84	50.02	-23.98	74	38.77	31.67	9.71	30.13	100	148	P	H
		5458.6	41.8	-12.2	54	30.5	31.7	9.74	30.14	100	148	A	H
		5025.48	50.49	-23.51	74	39.5	31.8	9.27	30.08	337	289	P	V
		5058.76	42.13	-11.87	54	31.02	31.9	9.3	30.09	337	289	A	V
*		5230	96.29	-	-	85.47	31.47	9.46	30.11	337	289	P	V
*		5230	88.5	-	-	77.68	31.47	9.46	30.11	337	289	A	V
	5433.4	50.04	-23.96	74	38.8	31.67	9.7	30.13	337	289	P	V	
	5459.16	41.84	-12.16	54	30.54	31.7	9.74	30.14	337	289	A	V	
Remark	1. No other spurious found. 2. All results are PASS against Peak and Average limit line.												



Band 1 5150~5250MHz
WIFI 802.11n HT40 (Harmonic @ 3m)

WIFI Ant. 1	Note	Frequency (MHz)	Level (dBμV/m)	Over Limit (dB)	Limit Line (dBμV/m)	Read Level (dBμV)	Antenna Factor (dB/m)	Path Loss (dB)	Preamp Factor (dB)	Ant Pos (cm)	Table Pos (deg)	Peak Avg. (P/A)	Pol. (H/V)	
802.11n HT40 CH 38 5190MHz		10380	46.63	-21.57	68.2	57.19	39.43	13.8	63.79	100	0	P	H	
		15570	45.76	-28.24	74	53.1	37.77	17.15	62.26	100	0	P	H	
													H	
													H	
			10380	46.96	-21.24	68.2	57.52	39.43	13.8	63.79	100	0	P	V
			15570	45.08	-28.92	74	52.42	37.77	17.15	62.26	100	0	P	V
														V
802.11n HT40 CH 46 5230MHz		10460	46.94	-21.26	68.2	57.2	39.55	13.87	63.68	100	0	P	H	
		15690	44.89	-29.11	74	52.6	37.35	17.28	62.34	100	0	P	H	
													H	
													H	
			10460	47.22	-20.98	68.2	57.48	39.55	13.87	63.68	100	0	P	V
			15690	45.8	-28.2	74	53.51	37.35	17.28	62.34	100	0	P	V
														V
Remark	1. No other spurious found.													
	2. All results are PASS against Peak and Average limit line.													



Band 1 5150~5250MHz
WIFI 802.11ac VHT80 (Band Edge @ 3m)

WIFI Ant. 1	Note	Frequency (MHz)	Level (dBμV/m)	Over Limit (dB)	Limit Line (dBμV/m)	Read Level (dBμV)	Antenna Factor (dB/m)	Path Loss (dB)	Preamp Factor (dB)	Ant Pos (cm)	Table Pos (deg)	Peak Avg. (P/A)	Pol. (H/V)
802.11ac VHT80 CH 42 5210MHz		5150	56.17	-17.83	74	45.08	31.8	9.39	30.1	100	150	P	H
		5150	48.45	-5.55	54	37.36	31.8	9.39	30.1	100	150	A	H
	*	5210	94.2	-	-	83.34	31.53	9.44	30.11	100	150	P	H
	*	5210	86.71	-	-	75.85	31.53	9.44	30.11	100	150	A	H
		5454.96	50.73	-23.27	74	39.43	31.7	9.74	30.14	100	150	P	H
		5444.32	42.08	-11.92	54	30.82	31.67	9.72	30.13	100	150	A	H
		5141.7	54.22	-19.78	74	43.14	31.8	9.38	30.1	323	287	P	V
		5147.42	46.35	-7.65	54	35.27	31.8	9.38	30.1	323	287	A	V
	*	5210	91.62	-	-	80.76	31.53	9.44	30.11	323	287	P	V
	*	5210	84.08	-	-	73.22	31.53	9.44	30.11	323	287	A	V
		5449.64	50.1	-23.9	74	38.8	31.7	9.73	30.13	323	287	P	V
	5441.24	41.64	-12.36	54	30.39	31.67	9.71	30.13	323	287	A	V	
Remark	1. No other spurious found. 2. All results are PASS against Peak and Average limit line.												



Band 1 5150~5250MHz
WIFI 802.11ac VHT80 (Harmonic @ 3m)

WIFI Ant. 1	Note	Frequency (MHz)	Level (dBμV/m)	Over Limit (dB)	Limit Line (dBμV/m)	Read Level (dBμV)	Antenna Factor (dB/m)	Path Loss (dB)	Preamp Factor (dB)	Ant Pos (cm)	Table Pos (deg)	Peak Avg. (P/A)	Pol. (H/V)	
802.11ac VHT80 CH 42 5210MHz		10420	46.9	-21.3	68.2	57.29	39.52	13.83	63.74	100	0	P	H	
		15630	45.68	-28.32	74	53.27	37.5	17.21	62.3	100	0	P	H	
													H	
													H	
			10420	45.87	-22.33	68.2	56.26	39.52	13.83	63.74	100	0	P	V
			15630	45.33	-28.67	74	52.92	37.5	17.21	62.3	100	0	P	V
														V
														V
Remark	1. No other spurious found. 2. All results are PASS against Peak and Average limit line.													



Band 2 - 5250~5350MHz
WIFI 802.11a (Band Edge @ 3m)

WIFI	Note	Frequency	Level	Over	Limit	Read	Antenna	Path	Preamp	Ant	Table	Peak	Pol.
Ant.				Limit	Line	Level	Factor	Loss	Factor	Pos	Pos	Avg.	
1		(MHz)	(dBμV/m)	(dB)	(dBμV/m)	(dBμV)	(dB/m)	(dB)	(dB)	(cm)	(deg)	(P/A)	(H/V)
802.11a CH 52 5260MHz		5041.14	49.92	-24.08	74	38.81	31.9	9.29	30.08	100	148	P	H
		5082.96	40.2	-13.8	54	29.07	31.9	9.32	30.09	100	148	A	H
	*	5260	103.39	-	-	92.61	31.4	9.49	30.11	100	148	P	H
	*	5260	95.58	-	-	84.8	31.4	9.49	30.11	100	148	A	H
		5373.6	50.57	-23.43	74	39.62	31.47	9.61	30.13	100	148	P	H
		5460	40.22	-13.78	54	28.92	31.7	9.74	30.14	100	148	A	H
		5118.66	50.83	-23.17	74	39.7	31.87	9.36	30.1	333	291	P	V
		5108.12	40.32	-13.68	54	29.19	31.87	9.35	30.09	333	291	A	V
	*	5260	100.34	-	-	89.56	31.4	9.49	30.11	333	291	P	V
	*	5260	92.37	-	-	81.59	31.4	9.49	30.11	333	291	A	V
		5439.36	51.23	-22.77	74	39.98	31.67	9.71	30.13	333	291	P	V
		5456.4	40.31	-13.69	54	29.01	31.7	9.74	30.14	333	291	A	V
802.11a CH 60 5300MHz		5110.16	50.09	-23.91	74	38.96	31.87	9.35	30.09	100	149	P	H
		5092.14	40.32	-13.68	54	29.18	31.9	9.33	30.09	100	149	A	H
	*	5300	103.61	-	-	92.8	31.4	9.53	30.12	100	149	P	H
	*	5300	96.01	-	-	85.2	31.4	9.53	30.12	100	149	A	H
		5350.56	50.2	-23.8	74	39.33	31.4	9.59	30.12	100	149	P	H
		5351.04	40.78	-13.22	54	29.91	31.4	9.59	30.12	100	149	A	H
		5100.98	49.85	-24.15	74	38.7	31.9	9.34	30.09	347	216	P	V
		5099.28	40.27	-13.73	54	29.12	31.9	9.34	30.09	347	216	A	V
	*	5300	99.73	-	-	88.92	31.4	9.53	30.12	347	216	P	V
	*	5300	91.94	-	-	81.13	31.4	9.53	30.12	347	216	A	V
		5351.76	51.18	-22.82	74	40.31	31.4	9.59	30.12	347	216	P	V
		5456.16	40.25	-13.75	54	28.95	31.7	9.74	30.14	347	216	A	V



802.11a CH 64 5320MHz	*	5320	103.25	-	-	92.41	31.4	9.56	30.12	100	151	P	H
	*	5320	95.55	-	-	84.71	31.4	9.56	30.12	100	151	A	H
		5352.96	50.81	-23.19	74	39.94	31.4	9.59	30.12	100	151	P	H
		5350.08	41.77	-12.23	54	30.9	31.4	9.59	30.12	100	151	A	H
													H
													H
	*	5320	100.74	-	-	89.9	31.4	9.56	30.12	358	194	P	V
	*	5320	93	-	-	82.16	31.4	9.56	30.12	358	194	A	V
		5351.36	50.35	-23.65	74	39.48	31.4	9.59	30.12	358	194	P	V
		5350.08	40.51	-13.49	54	29.64	31.4	9.59	30.12	358	194	A	V
													V
													V
Remark	1. No other spurious found. 2. All results are PASS against Peak and Average limit line.												



Band 2 5250~5350MHz
WIFI 802.11a (Harmonic @ 3m)

WIFI Ant. 1	Note	Frequency (MHz)	Level (dBμV/m)	Over Limit (dB)	Limit Line (dBμV/m)	Read Level (dBμV)	Antenna Factor (dB/m)	Path Loss (dB)	Preamp Factor (dB)	Ant Pos (cm)	Table Pos (deg)	Peak Avg. (P/A)	Pol. (H/V)
802.11a CH 52 5260MHz		10520	46.02	-22.18	68.2	56.13	39.63	13.9	63.64	100	0	P	H
		15780	45.39	-28.61	74	53.15	37.3	17.34	62.4	100	0	P	H
													H
													H
		10520	46.16	-22.04	68.2	56.27	39.63	13.9	63.64	100	0	P	V
		15780	47.51	-26.49	74	55.27	37.3	17.34	62.4	100	0	P	V
													V
													V
802.11a CH 60 5300MHz		10600	46.36	-27.64	74	56.33	39.8	13.92	63.69	100	0	P	H
		15900	46.37	-27.63	74	54.41	37	17.44	62.48	100	0	P	H
													H
													H
		10600	46.93	-27.07	74	56.9	39.8	13.92	63.69	100	0	P	V
		15900	54.71	-19.29	74	62.75	37	17.44	62.48	120	261	P	V
		15900	42.93	-11.07	54	50.97	37	17.44	62.48	120	261	A	V
													V
802.11a CH 64 5320MHz		10640	46.98	-27.02	74	56.97	39.8	13.93	63.72	100	0	P	H
		15960	45.1	-28.9	74	53.3	36.93	17.39	62.52	100	0	P	H
													H
													H
		10640	47.2	-26.8	74	57.19	39.8	13.93	63.72	100	0	P	V
		15960	49.81	-24.19	74	58.01	36.93	17.39	62.52	100	0	P	V
													V
													V
Remark	1. No other spurious found. 2. All results are PASS against Peak and Average limit line.												



**Band 2 5250~5350MHz
WIFI 802.11n HT20 (Band Edge @ 3m)**

WIFI Ant. 1	Note	Frequency (MHz)	Level (dBμV/m)	Over Limit (dB)	Limit Line (dBμV/m)	Read Level (dBμV)	Antenna Factor (dB/m)	Path Loss (dB)	Preamp Factor (dB)	Ant Pos (cm)	Table Pos (deg)	Peak Avg. (P/A)	Pol. (H/V)	
802.11n HT20 CH 52 5260MHz		5119.68	50.78	-23.22	74	39.65	31.87	9.36	30.1	100	147	P	H	
		5097.58	41.08	-12.92	54	29.93	31.9	9.34	30.09	100	147	A	H	
	*	5260	102.74	-	-	91.96	31.4	9.49	30.11	100	147	P	H	
	*	5260	95.02	-	-	84.24	31.4	9.49	30.11	100	147	A	H	
		5424	50.53	-23.47	74	39.35	31.63	9.68	30.13	100	147	P	H	
		5454.72	41	-13	54	29.7	31.7	9.74	30.14	100	147	A	H	
		5112.54	51.06	-22.94	74	39.93	31.87	9.35	30.09	333	291	P	V	
		5069.7	41.17	-12.83	54	30.05	31.9	9.31	30.09	333	291	A	V	
	*	5260	99.13	-	-	88.35	31.4	9.49	30.11	333	291	P	V	
	*	5260	91.55	-	-	80.77	31.4	9.49	30.11	333	291	A	V	
		5454.96	50.02	-23.98	74	38.72	31.7	9.74	30.14	333	291	P	V	
		5457.6	40.98	-13.02	54	29.68	31.7	9.74	30.14	333	291	A	V	
	802.11n HT20 CH 60 5300MHz		5097.58	50.08	-23.92	74	38.93	31.9	9.34	30.09	100	149	P	H
			5088.06	41.19	-12.81	54	30.05	31.9	9.33	30.09	100	149	A	H
*		5300	102.27	-	-	91.46	31.4	9.53	30.12	100	149	P	H	
*		5300	94.82	-	-	84.01	31.4	9.53	30.12	100	149	A	H	
		5392.8	50.75	-23.25	74	39.72	31.53	9.63	30.13	100	149	P	H	
		5353.2	41.53	-12.47	54	30.66	31.4	9.59	30.12	100	149	A	H	
		5147.9	50.23	-23.77	74	39.15	31.8	9.38	30.1	347	218	P	V	
		5089.76	41.22	-12.78	54	30.08	31.9	9.33	30.09	347	218	A	V	
*		5300	98.36	-	-	87.55	31.4	9.53	30.12	347	218	P	V	
*		5300	90.98	-	-	80.17	31.4	9.53	30.12	347	218	A	V	
	5411.28	50.88	-23.12	74	39.75	31.6	9.66	30.13	347	218	P	V		
	5458.32	41.11	-12.89	54	29.81	31.7	9.74	30.14	347	218	A	V		



802.11n HT20 CH 64 5320MHz	*	5320	102.24	-	-	91.4	31.4	9.56	30.12	100	149	P	H
	*	5320	94.54	-	-	83.7	31.4	9.56	30.12	100	149	A	H
		5358.24	51.96	-22.04	74	41.08	31.4	9.6	30.12	100	149	P	H
		5352.16	42.28	-11.72	54	31.41	31.4	9.59	30.12	100	149	A	H
													H
													H
	*	5320	99.51	-	-	88.67	31.4	9.56	30.12	357	193	P	V
	*	5320	91.88	-	-	81.04	31.4	9.56	30.12	357	193	A	V
		5352	50.18	-23.82	74	39.31	31.4	9.59	30.12	357	193	P	V
		5352	41.26	-12.74	54	30.39	31.4	9.59	30.12	357	193	A	V
													V
													V
Remark	1. No other spurious found. 2. All results are PASS against Peak and Average limit line.												



Band 2 5250~5350MHz
WIFI 802.11n HT20 (Harmonic @ 3m)

WIFI Ant. 1	Note	Frequency (MHz)	Level (dBµV/m)	Over Limit (dB)	Limit Line (dBµV/m)	Read Level (dBµV)	Antenna Factor (dB/m)	Path Loss (dB)	Preamp Factor (dB)	Ant Pos (cm)	Table Pos (deg)	Peak Avg. (P/A)	Pol. (H/V)
802.11n HT20 CH 52 5260MHz		10520	45.69	-22.51	68.2	55.8	39.63	13.9	63.64	100	0	P	H
		15780	44.68	-29.32	74	52.44	37.3	17.34	62.4	100	0	P	H
													H
													H
		10520	45.28	-22.92	68.2	55.39	39.63	13.9	63.64	100	0	P	V
		15780	45.91	-28.09	74	53.67	37.3	17.34	62.4	100	0	P	V
													V
													V
802.11n HT20 CH 60 5300MHz		10600	46.5	-27.5	74	56.47	39.8	13.92	63.69	100	0	P	H
		15900	45.71	-28.29	74	53.75	37	17.44	62.48	100	0	P	H
													H
													H
		10600	47.29	-26.71	74	57.26	39.8	13.92	63.69	100	0	P	V
		15900	48.98	-25.02	74	57.02	37	17.44	62.48	100	0	P	V
													V
													V
802.11n HT20 CH 64 5320MHz		10640	46.31	-27.69	74	56.3	39.8	13.93	63.72	100	0	P	H
		15960	44.47	-29.53	74	52.67	36.93	17.39	62.52	100	0	P	H
													H
													H
		10640	46.42	-27.58	74	56.41	39.8	13.93	63.72	100	0	P	V
		15960	49.47	-24.53	74	57.67	36.93	17.39	62.52	100	0	P	V
													V
													V
Remark	1. No other spurious found. 2. All results are PASS against Peak and Average limit line.												



Band 2 5250~5350MHz
WIFI 802.11n HT40 (Band Edge @ 3m)

WIFI Ant. 1	Note	Frequency (MHz)	Level (dBμV/m)	Over Limit (dB)	Limit Line (dBμV/m)	Read Level (dBμV)	Antenna Factor (dB/m)	Path Loss (dB)	Preamp Factor (dB)	Ant Pos (cm)	Table Pos (deg)	Peak Avg. (P/A)	Pol. (H/V)
802.11n HT40 CH 54 5270MHz		5143.82	50.48	-23.52	74	39.4	31.8	9.38	30.1	100	133	P	H
		5097.92	42.08	-11.92	54	30.93	31.9	9.34	30.09	100	133	A	H
	*	5270	99.73	-	-	88.94	31.4	9.5	30.11	100	133	P	H
	*	5270	91.96	-	-	81.17	31.4	9.5	30.11	100	133	A	H
		5359.68	50.71	-23.29	74	39.83	31.4	9.6	30.12	100	133	P	H
		5350.56	42.3	-11.7	54	31.43	31.4	9.59	30.12	100	133	A	H
		5088.06	51.14	-22.86	74	40	31.9	9.33	30.09	332	290	P	V
		5115.94	42.22	-11.78	54	31.09	31.87	9.35	30.09	332	290	A	V
	*	5270	95.62	-	-	84.83	31.4	9.5	30.11	332	290	P	V
	*	5270	88.1	-	-	77.31	31.4	9.5	30.11	332	290	A	V
		5433.6	51.31	-22.69	74	40.07	31.67	9.7	30.13	332	290	P	V
		5456.64	41.96	-12.04	54	30.66	31.7	9.74	30.14	332	290	A	V
802.11n HT40 CH 62 5310MHz		5129.88	50.14	-23.86	74	39.04	31.83	9.37	30.1	100	149	P	H
		5112.88	41.71	-12.29	54	30.58	31.87	9.35	30.09	100	149	A	H
	*	5310	99.54	-	-	88.71	31.4	9.55	30.12	100	149	P	H
	*	5310	91.84	-	-	81.01	31.4	9.55	30.12	100	149	A	H
		5350.8	54.81	-19.19	74	43.94	31.4	9.59	30.12	100	149	P	H
		5350.08	48.96	-5.04	54	38.09	31.4	9.59	30.12	100	149	A	H
		5088.06	49.87	-24.13	74	38.73	31.9	9.33	30.09	345	217	P	V
		5136.68	41.89	-12.11	54	30.79	31.83	9.37	30.1	345	217	A	V
	*	5310	95.63	-	-	84.8	31.4	9.55	30.12	345	217	P	V
	*	5310	87.93	-	-	77.1	31.4	9.55	30.12	345	217	A	V
	5353.92	51.52	-22.48	74	40.65	31.4	9.59	30.12	345	217	P	V	
	5350.32	44.62	-9.38	54	33.75	31.4	9.59	30.12	345	217	A	V	
Remark	1. No other spurious found. 2. All results are PASS against Peak and Average limit line.												



Band 2 5250~5350MHz
WIFI 802.11n HT40 (Harmonic @ 3m)

WIFI Ant. 1	Note	Frequency (MHz)	Level (dBμV/m)	Over Limit (dB)	Limit Line (dBμV/m)	Read Level (dBμV)	Antenna Factor (dB/m)	Path Loss (dB)	Preamp Factor (dB)	Ant Pos (cm)	Table Pos (deg)	Peak Avg. (P/A)	Pol. (H/V)	
802.11n HT40 CH 54 5270MHz		10540	46.4	-21.8	68.2	56.47	39.67	13.91	63.65	100	0	P	H	
		15810	44.98	-29.02	74	52.73	37.3	17.37	62.42	100	0	P	H	
													H	
													H	
			10540	46.3	-21.9	68.2	56.37	39.67	13.91	63.65	100	0	P	V
			15810	45.19	-28.81	74	52.94	37.3	17.37	62.42	100	0	P	V
														V
802.11n HT40 CH 62 5310MHz		10620	46.62	-27.38	74	56.59	39.8	13.93	63.7	100	0	P	H	
		15930	43.57	-30.43	74	51.68	36.97	17.42	62.5	100	0	P	H	
													H	
													H	
			10620	46.9	-27.1	74	56.87	39.8	13.93	63.7	100	0	P	V
			15930	44.42	-29.58	74	52.53	36.97	17.42	62.5	100	0	P	V
														V
Remark	1. No other spurious found.													
	2. All results are PASS against Peak and Average limit line.													



Band 2 5250~5350MHz
WIFI 802.11ac VHT80 (Band Edge @ 3m)

WIFI Ant. 1	Note	Frequency (MHz)	Level (dBμV/m)	Over Limit (dB)	Limit Line (dBμV/m)	Read Level (dBμV)	Antenna Factor (dB/m)	Path Loss (dB)	Preamp Factor (dB)	Ant Pos (cm)	Table Pos (deg)	Peak Avg. (P/A)	Pol. (H/V)
802.11ac VHT80 CH 58 5290MHz		5132.6	51.05	-22.95	74	39.95	31.83	9.37	30.1	100	147	P	H
		5106.42	42.07	-11.93	54	30.94	31.87	9.35	30.09	100	147	A	H
	*	5290	96.02	-	-	85.21	31.4	9.52	30.11	100	147	P	H
	*	5290	88.47	-	-	77.66	31.4	9.52	30.11	100	147	A	H
		5350.32	59.28	-14.72	74	48.41	31.4	9.59	30.12	100	147	P	H
		5350.56	49.7	-4.3	54	38.83	31.4	9.59	30.12	100	147	A	H
		5034.34	50.23	-23.77	74	39.23	31.8	9.28	30.08	348	216	P	V
		5101.32	42.1	-11.9	54	30.95	31.9	9.34	30.09	348	216	A	V
	*	5290	92.05	-	-	81.24	31.4	9.52	30.11	348	216	P	V
	*	5290	84.59	-	-	73.78	31.4	9.52	30.11	348	216	A	V
		5352.96	52.17	-21.83	74	41.3	31.4	9.59	30.12	348	216	P	V
	5350.08	45.18	-8.82	54	34.31	31.4	9.59	30.12	348	216	A	V	
Remark	1. No other spurious found. 2. All results are PASS against Peak and Average limit line.												



**Band 2 5250~5350MHz
WIFI 802.11ac VHT80 (Harmonic @ 3m)**

WIFI Ant. 1	Note	Frequency (MHz)	Level (dBμV/m)	Over Limit (dB)	Limit Line (dBμV/m)	Read Level (dBμV)	Antenna Factor (dB/m)	Path Loss (dB)	Preamp Factor (dB)	Ant Pos (cm)	Table Pos (deg)	Peak Avg. (P/A)	Pol. (H/V)	
802.11ac VHT80 CH 58 5290MHz		10580	47.55	-20.65	68.2	57.54	39.77	13.92	63.68	100	0	P	H	
		15870	44.64	-29.36	74	52.62	37.06	17.42	62.46	100	0	P	H	
													H	
													H	
			10580	47.81	-20.39	68.2	57.8	39.77	13.92	63.68	100	0	P	V
			15870	44.3	-29.7	74	52.28	37.06	17.42	62.46	100	0	P	V
														V
														V
Remark	1. No other spurious found. 2. All results are PASS against Peak and Average limit line.													



Band 3 - 5470~5725MHz
WIFI 802.11a (Band Edge @ 3m)

WIFI	Note	Frequency	Level	Over	Limit	Read	Antenna	Path	Preamp	Ant	Table	Peak	Pol.	
Ant.				Limit	Line	Level	Factor	Loss	Factor	Pos	Pos	Avg.		
1		(MHz)	(dBμV/m)	(dB)	(dBμV/m)	(dBμV)	(dB/m)	(dB)	(dB)	(cm)	(deg)	(P/A)	(H/V)	
802.11a CH 100 5500MHz		5457.84	51.7	-22.3	74	40.4	31.7	9.74	30.14	100	149	P	H	
		5469.52	53.01	-15.19	68.2	41.69	31.7	9.76	30.14	100	149	P	H	
		5459.12	41.96	-12.04	54	30.66	31.7	9.74	30.14	100	149	A	H	
	*	5500	101.86	-	-	90.48	31.7	9.82	30.14	100	149	P	H	
	*	5500	94.11	-	-	82.73	31.7	9.82	30.14	100	149	A	H	
														H
			5433.04	51.23	-22.77	74	39.99	31.67	9.7	30.13	392	191	P	V
			5469.2	51.17	-17.03	68.2	39.85	31.7	9.76	30.14	392	191	P	V
			5458.48	41.4	-12.6	54	30.1	31.7	9.74	30.14	392	191	A	V
	*		5500	99.97	-	-	88.59	31.7	9.82	30.14	392	191	P	V
	*		5500	92.5	-	-	81.12	31.7	9.82	30.14	392	191	A	V
														V
802.11a CH 116 5580MHz		5387.92	51.8	-22.2	74	40.77	31.53	9.63	30.13	100	150	P	H	
		5468.56	50.19	-18.01	68.2	38.87	31.7	9.76	30.14	100	150	P	H	
		5457.52	41.4	-12.6	54	30.1	31.7	9.74	30.14	100	150	A	H	
	*	5580	102.82	-	-	91.26	31.8	9.95	30.19	100	150	P	H	
	*	5580	95.19	-	-	83.63	31.8	9.95	30.19	100	150	A	H	
			5753.66	50.8	-17.4	68.2	38.98	32.07	10.02	30.27	100	150	P	H
			5409.76	50.5	-23.5	74	39.37	31.6	9.66	30.13	360	202	P	V
			5461.12	49.74	-18.46	68.2	38.43	31.7	9.75	30.14	360	202	P	V
			5455.84	41.12	-12.88	54	29.82	31.7	9.74	30.14	360	202	A	V
	*		5580	101.55	-	-	89.99	31.8	9.95	30.19	360	202	P	V
	*		5580	93.54	-	-	81.98	31.8	9.95	30.19	360	202	A	V
			5765	50.24	-17.96	68.2	38.44	32.07	10.02	30.29	360	202	P	V



802.11a CH 140 5700MHz	*	5700	104.86	-	-	93.3	31.8	10.01	30.25	100	151	P	H
	*	5700	97.02	-	-	85.46	31.8	10.01	30.25	100	151	A	H
		5725.72	55.5	-12.7	68.2	43.81	31.93	10.02	30.26	100	151	P	H
													H
													H
													H
	*	5700	104.28	-	-	92.72	31.8	10.01	30.25	346	208	P	V
	*	5700	96.77	-	-	85.21	31.8	10.01	30.25	346	208	A	V
		5725.48	53.31	-14.89	68.2	41.62	31.93	10.02	30.26	346	208	P	V
													V
													V
													V
	Remark	1. No other spurious found. 2. All results are PASS against Peak and Average limit line.											



Band 3 - 5470~5725MHz
WIFI 802.11a (Harmonic @ 3m)

WIFI Ant. 1	Note	Frequency (MHz)	Level (dBµV/m)	Over Limit (dB)	Limit Line (dBµV/m)	Read Level (dBµV)	Antenna Factor (dB/m)	Path Loss (dB)	Preamp Factor (dB)	Ant Pos (cm)	Table Pos (deg)	Peak Avg. (P/A)	Pol. (H/V)
802.11a CH 100 5500MHz		11000	47.14	-26.86	74	56.6	40.4	14.08	63.94	100	0	P	H
		16500	45.39	-22.81	68.2	52.04	38.6	17.67	62.92	100	0	P	H
													H
													H
		11000	49.12	-24.88	74	58.58	40.4	14.08	63.94	100	0	P	V
		16500	45.14	-23.06	68.2	51.79	38.6	17.67	62.92	100	0	P	V
													V
													V
802.11a CH 116 5580MHz		11160	46.93	-27.07	74	56.3	39.93	14.33	63.63	100	0	P	H
		16740	47.82	-20.38	68.2	52.6	39.78	18.05	62.61	100	0	P	H
													H
													H
		11160	48	-26	74	57.37	39.93	14.33	63.63	100	0	P	V
		16740	47.38	-20.82	68.2	52.16	39.78	18.05	62.61	100	0	P	V
													V
													V
802.11a CH 140 5700MHz		11400	48.56	-25.44	74	57.05	40	14.67	63.16	100	0	P	H
		17100	48.2	-20	68.2	51.55	40.5	18.4	62.25	100	0	P	H
													H
													H
		11400	49.09	-24.91	74	57.58	40	14.67	63.16	100	0	P	V
		17100	48.17	-20.03	68.2	51.52	40.5	18.4	62.25	100	0	P	V
													V
													V
Remark	1. No other spurious found. 2. All results are PASS against Peak and Average limit line.												



Band 3 - 5470~5725MHz
WIFI 802.11n HT20 (Band Edge @ 3m)

WIFI Ant. 1	Note	Frequency (MHz)	Level (dBμV/m)	Over Limit (dB)	Limit Line (dBμV/m)	Read Level (dBμV)	Antenna Factor (dB/m)	Path Loss (dB)	Preamp Factor (dB)	Ant Pos (cm)	Table Pos (deg)	Peak Avg. (P/A)	Pol. (H/V)	
802.11n HT20 CH 100 5500MHz		5452.4	53.11	-20.89	74	41.82	31.7	9.73	30.14	100	150	P	H	
		5463.6	51.24	-16.96	68.2	39.93	31.7	9.75	30.14	100	150	P	H	
		5449.36	41.93	-12.07	54	30.63	31.7	9.73	30.13	100	150	A	H	
	*	5500	100.26	-	-	88.88	31.7	9.82	30.14	100	150	P	H	
	*	5500	92.57	-	-	81.19	31.7	9.82	30.14	100	150	A	H	
														H
			5457.52	50.25	-23.75	74	38.95	31.7	9.74	30.14	394	191	P	V
			5463.12	52.64	-15.56	68.2	41.33	31.7	9.75	30.14	394	191	P	V
			5453.36	41.45	-12.55	54	30.16	31.7	9.73	30.14	394	191	A	V
	*		5500	98.49	-	-	87.11	31.7	9.82	30.14	394	191	P	V
	*		5500	90.67	-	-	79.29	31.7	9.82	30.14	394	191	A	V
														V
802.11n HT20 CH 116 5580MHz		5431.12	50.56	-23.44	74	39.33	31.67	9.69	30.13	100	149	P	H	
		5470	50.64	-17.56	68.2	39.32	31.7	9.76	30.14	100	149	P	H	
		5458.24	41.25	-12.75	54	29.95	31.7	9.74	30.14	100	149	A	H	
	*	5580	101.57	-	-	90.01	31.8	9.95	30.19	100	149	P	H	
	*	5580	93.6	-	-	82.04	31.8	9.95	30.19	100	149	A	H	
			5748.62	50.04	-18.16	68.2	38.29	32	10.02	30.27	100	149	P	H
			5427.76	51.1	-22.9	74	39.91	31.63	9.69	30.13	363	202	P	V
			5460.4	50.51	-17.69	68.2	39.2	31.7	9.75	30.14	363	202	P	V
			5441.2	41.13	-12.87	54	29.88	31.67	9.71	30.13	363	202	A	V
	*		5580	99.86	-	-	88.3	31.8	9.95	30.19	363	202	P	V
	*		5580	92.31	-	-	80.75	31.8	9.95	30.19	363	202	A	V
			5740.745	50.09	-18.11	68.2	38.34	32	10.02	30.27	363	202	P	V



802.11n HT20 CH 140 5700MHz	*	5700	104.14	-	-	92.58	31.8	10.01	30.25	100	148	P	H
	*	5700	96.31	-	-	84.75	31.8	10.01	30.25	100	148	A	H
		5725.24	53.85	-14.35	68.2	42.16	31.93	10.02	30.26	100	148	P	H
													H
													H
													H
	*	5700	103.94	-	-	92.38	31.8	10.01	30.25	343	209	P	V
	*	5700	96.28	-	-	84.72	31.8	10.01	30.25	343	209	A	V
		5725.08	54.91	-13.29	68.2	43.22	31.93	10.02	30.26	343	209	P	V
													V
													V
													V
Remark	1. No other spurious found. 2. All results are PASS against Peak and Average limit line.												



Band 3 - 5470~5725MHz
WIFI 802.11n HT20 (Harmonic @ 3m)

WIFI Ant. 1	Note	Frequency (MHz)	Level (dBμV/m)	Over Limit (dB)	Limit Line (dBμV/m)	Read Level (dBμV)	Antenna Factor (dB/m)	Path Loss (dB)	Preamp Factor (dB)	Ant Pos (cm)	Table Pos (deg)	Peak Avg. (P/A)	Pol. (H/V)
802.11n HT20 CH 100 5500MHz		11000	47.28	-26.72	74	56.74	40.4	14.08	63.94	100	0	P	H
		16500	45.91	-22.29	68.2	52.56	38.6	17.67	62.92	100	0	P	H
													H
													H
		11000	47.73	-26.27	74	57.19	40.4	14.08	63.94	100	0	P	V
		16500	45.24	-22.96	68.2	51.89	38.6	17.67	62.92	100	0	P	V
													V
													V
802.11n HT20 CH 116 5580MHz		11160	47.84	-26.16	74	57.21	39.93	14.33	63.63	100	0	P	H
		16740	47.89	-20.31	68.2	52.67	39.78	18.05	62.61	100	0	P	H
													H
													H
		11160	47.5	-26.5	74	56.87	39.93	14.33	63.63	100	0	P	V
		16740	47.62	-20.58	68.2	52.4	39.78	18.05	62.61	100	0	P	V
													V
													V
802.11n HT20 CH 140 5700MHz		11400	48.51	-25.49	74	57	40	14.67	63.16	100	0	P	H
		17100	48.7	-19.5	68.2	52.05	40.5	18.4	62.25	100	0	P	H
													H
													H
		11400	48.67	-25.33	74	57.16	40	14.67	63.16	100	0	P	V
		17100	47.75	-20.45	68.2	51.1	40.5	18.4	62.25	100	0	P	V
													V
													V
Remark	1. No other spurious found. 2. All results are PASS against Peak and Average limit line.												



Band 3 - 5470~5725MHz
WIFI 802.11n HT40 (Band Edge @ 3m)

WIFI Ant. 1	Note	Frequency (MHz)	Level (dBμV/m)	Over Limit (dB)	Limit Line (dBμV/m)	Read Level (dBμV)	Antenna Factor (dB/m)	Path Loss (dB)	Preamp Factor (dB)	Ant Pos (cm)	Table Pos (deg)	Peak Avg. (P/A)	Pol. (H/V)
802.11n HT40 CH 102 5510MHz		5420.8	51.09	-22.91	74	39.91	31.63	9.68	30.13	100	150	P	H
		5470	54.47	-13.73	68.2	43.15	31.7	9.76	30.14	100	150	P	H
		5459.2	43.41	-10.59	54	32.11	31.7	9.74	30.14	100	150	A	H
	*	5510	98.08	-	-	86.7	31.7	9.83	30.15	100	150	P	H
	*	5510	90.13	-	-	78.75	31.7	9.83	30.15	100	150	A	H
		5749.25	51.63	-16.57	68.2	39.88	32	10.02	30.27	100	150	P	H
		5454.4	50.44	-23.56	74	39.14	31.7	9.74	30.14	391	202	P	V
		5467.36	52.37	-15.83	68.2	41.05	31.7	9.76	30.14	391	202	P	V
		5423.68	42.39	-11.61	54	31.21	31.63	9.68	30.13	391	202	A	V
	*	5510	96.85	-	-	85.47	31.7	9.83	30.15	391	202	P	V
	*	5510	88.74	-	-	77.36	31.7	9.83	30.15	391	202	A	V
		5756.18	50.69	-17.51	68.2	38.89	32.07	10.02	30.29	391	202	P	V
802.11n HT40 CH 110 5550MHz		5379.52	50.52	-23.48	74	39.5	31.53	9.62	30.13	100	148	P	H
		5463.04	51.6	-16.6	68.2	40.29	31.7	9.75	30.14	100	148	P	H
		5449.6	42.48	-11.52	54	31.18	31.7	9.73	30.13	100	148	A	H
	*	5550	98.44	-	-	86.91	31.8	9.9	30.17	100	148	P	H
	*	5550	90.58	-	-	79.05	31.8	9.9	30.17	100	148	A	H
		5731.61	50.43	-17.77	68.2	38.75	31.93	10.02	30.27	100	148	P	H
		5454.64	51.5	-22.5	74	40.2	31.7	9.74	30.14	382	205	P	V
		5464.72	50.71	-17.49	68.2	39.4	31.7	9.75	30.14	382	205	P	V
		5457.28	42.25	-11.75	54	30.95	31.7	9.74	30.14	382	205	A	V
	*	5550	97.15	-	-	85.62	31.8	9.9	30.17	382	205	P	V
	*	5550	89.34	-	-	77.81	31.8	9.9	30.17	382	205	A	V
		5752.715	51.54	-16.66	68.2	39.72	32.07	10.02	30.27	382	205	P	V



802.11n HT40 CH 134 5670MHz		5416.85	50.29	-23.71	74	39.12	31.63	9.67	30.13	100	150	P	H
		5466.9	50.5	-17.7	68.2	39.18	31.7	9.76	30.14	100	150	P	H
		5455	42.18	-11.82	54	30.88	31.7	9.74	30.14	100	150	A	H
	*	5670	100.66	-	-	89.14	31.75	10	30.23	100	150	P	H
	*	5670	92.69	-	-	81.17	31.75	10	30.23	100	150	A	H
		5730.875	54.09	-14.11	68.2	42.41	31.93	10.02	30.27	100	150	P	H
		5459.55	49.9	-24.1	74	38.6	31.7	9.74	30.14	366	209	P	V
		5466.9	50.07	-18.13	68.2	38.75	31.7	9.76	30.14	366	209	P	V
		5458.85	42.1	-11.9	54	30.8	31.7	9.74	30.14	366	209	A	V
	*	5670	100.3	-	-	88.78	31.75	10	30.23	366	209	P	V
	*	5670	92.4	-	-	80.88	31.75	10	30.23	366	209	A	V
		5731.05	52.4	-15.8	68.2	40.72	31.93	10.02	30.27	366	209	P	V
Remark	1. No other spurious found. 2. All results are PASS against Peak and Average limit line.												



Band 3 - 5470~5725MHz
WIFI 802.11n HT40 (Harmonic @ 3m)

WIFI Ant. 1	Note	Frequency (MHz)	Level (dBμV/m)	Over Limit (dB)	Limit Line (dBμV/m)	Read Level (dBμV)	Antenna Factor (dB/m)	Path Loss (dB)	Preamp Factor (dB)	Ant Pos (cm)	Table Pos (deg)	Peak Avg. (P/A)	Pol. (H/V)
802.11n HT40 CH 102 5510MHz		11020	47.78	-26.22	74	57.24	40.33	14.11	63.9	100	0	P	H
		16530	47.24	-20.96	68.2	53.71	38.7	17.71	62.88	100	0	P	H
													H
													H
		11020	48.59	-25.41	74	58.05	40.33	14.11	63.9	100	0	P	V
		16530	45.4	-22.8	68.2	51.87	38.7	17.71	62.88	100	0	P	V
802.11n HT40 CH 110 5550MHz		11100	47.02	-26.98	74	56.59	40	14.18	63.75	100	0	P	H
		16650	46.29	-21.91	68.2	51.88	39.2	17.94	62.73	100	0	P	H
													H
													H
		11100	47.13	-26.87	74	56.7	40	14.18	63.75	100	0	P	V
		16650	46.35	-21.85	68.2	51.94	39.2	17.94	62.73	100	0	P	V
802.11n HT40 CH 134 5670MHz		11340	48.4	-25.6	74	57.12	39.87	14.69	63.28	100	0	P	H
		17010	48.4	-19.8	68.2	51.93	40.5	18.25	62.28	100	0	P	H
													H
													H
		11340	49.53	-24.47	74	58.25	39.87	14.69	63.28	100	0	P	V
		17010	48.2	-20	68.2	51.73	40.5	18.25	62.28	100	0	P	V
Remark	1. No other spurious found.												
	2. All results are PASS against Peak and Average limit line.												



Band 3 - 5470~5725MHz
WIFI 802.11ac VHT80 (Band Edge @ 3m)

WIFI Ant. 1	Note	Frequency (MHz)	Level (dBμV/m)	Over Limit (dB)	Limit Line (dBμV/m)	Read Level (dBμV)	Antenna Factor (dB/m)	Path Loss (dB)	Preamp Factor (dB)	Ant Pos (cm)	Table Pos (deg)	Peak Avg. (P/A)	Pol. (H/V)
802.11ac VHT80 CH 106 5530MHz		5456.8	54.86	-19.14	74	43.56	31.7	9.74	30.14	100	149	P	H
		5470	55.59	-12.61	68.2	44.27	31.7	9.76	30.14	100	149	P	H
		5458.48	46.59	-7.41	54	35.29	31.7	9.74	30.14	100	149	A	H
	*	5530	94.03	-	-	82.6	31.73	9.87	30.17	100	149	P	H
	*	5530	86.33	-	-	74.9	31.73	9.87	30.17	100	149	A	H
		5764.37	51.21	-16.99	68.2	39.41	32.07	10.02	30.29	100	149	P	H
		5446.24	52.96	-21.04	74	41.67	31.7	9.72	30.13	388	205	P	V
		5463.76	52.04	-16.16	68.2	40.73	31.7	9.75	30.14	388	205	P	V
		5452.24	44.44	-9.56	54	33.15	31.7	9.73	30.14	388	205	A	V
	*	5530	92.47	-	-	81.04	31.73	9.87	30.17	388	205	P	V
	*	5530	84.75	-	-	73.32	31.73	9.87	30.17	388	205	A	V
		5726.885	51.22	-16.98	68.2	39.53	31.93	10.02	30.26	388	205	P	V
Remark	1. No other spurious found. 2. All results are PASS against Peak and Average limit line.												



**Band 3 5470~5725MHz
WIFI 802.11ac VHT80 (Harmonic @ 3m)**

WIFI Ant. 1	Note	Frequency (MHz)	Level (dBμV/m)	Over Limit (dB)	Limit Line (dBμV/m)	Read Level (dBμV)	Antenna Factor (dB/m)	Path Loss (dB)	Preamp Factor (dB)	Ant Pos (cm)	Table Pos (deg)	Peak Avg. (P/A)	Pol. (H/V)	
802.11ac VHT80 CH 106 5530MHz		11060	48.19	-25.81	74	57.74	40.13	14.14	63.82	100	0	P	H	
		16590	47.3	-20.9	68.2	53.43	38.85	17.82	62.8	100	0	P	H	
													H	
													H	
			11060	47.47	-26.53	74	57.02	40.13	14.14	63.82	100	0	P	V
			16590	47.52	-20.68	68.2	53.65	38.85	17.82	62.8	100	0	P	V
														V
														V
Remark	1. No other spurious found. 2. All results are PASS against Peak and Average limit line.													



Emission below 1GHz
WIFI 802.11ac VHT80 (LF @ 3m)

WIFI Ant. 1	Note	Frequency (MHz)	Level (dBμV/m)	Over Limit (dB)	Limit Line (dBμV/m)	Read Level (dBμV)	Antenna Factor (dB/m)	Path Loss (dB)	Preamp Factor (dB)	Ant Pos (cm)	Table Pos (deg)	Peak Avg. (P/A)	Pol. (H/V)	
802.11ac VHT80 LF		30	23.47	-16.53	40	30.14	25.2	0.75	32.62	-	-	P	H	
		162.89	21.43	-22.07	43.5	35.87	16.21	1.68	32.5	-	-	P	H	
		202.66	20.32	-23.18	43.5	35.67	15.11	1.86	32.49	-	-	P	H	
		262.8	20.73	-25.27	46	30.96	20	2.11	32.52	-	-	P	H	
		563.5	28.02	-17.98	46	30.96	26.37	3.1	32.59	-	-	P	H	
		762.35	30.66	-15.34	46	30.8	28.45	3.55	32.28	100	0	P	H	
														H
														H
														H
														H
														H
														H
			30	33.11	-6.89	40	39.78	25.2	0.75	32.62	100	0	P	V
			80.44	20.26	-19.74	40	38.03	13.5	1.18	32.54	-	-	P	V
			104.69	18.61	-24.89	43.5	33.08	16.61	1.35	32.51	-	-	P	V
			258.92	20.55	-25.45	46	30.98	19.83	2.09	32.52	-	-	P	V
			631.4	28	-18	46	30.68	26.46	3.24	32.54	-	-	P	V
			775.93	30.85	-15.15	46	30.97	28.4	3.58	32.25	-	-	P	V
														V
														V
													V	
													V	
													V	
													V	
Remark	1. No other spurious found. 2. All results are PASS against limit line.													



Note symbol

*	Fundamental Frequency which can be ignored. However, the level of any unwanted emissions shall not exceed the level of the fundamental frequency.
!	Test result is over limit line.
P/A	Peak or Average
H/V	Horizontal or Vertical



A calculation example for radiated spurious emission is shown as below:

WIFI	Note	Frequency	Level	Over	Limit	Read	Antenna	Path	Preamp	Ant	Table	Peak	Pol.
Ant.				Limit	Line	Level	Factor	Loss	Factor	Pos	Pos	Avg.	
1		(MHz)	(dBμV/m)	(dB)	(dBμV/m)	(dBμV)	(dB/m)	(dB)	(dB)	(cm)	(deg)	(P/A)	(H/V)
802.11b		2390	55.45	-18.55	74	54.51	32.22	4.58	35.86	103	308	P	H
CH 01													
2412MHz		2390	43.54	-10.46	54	42.6	32.22	4.58	35.86	103	308	A	H

1. Path Loss(dB) = Cable loss(dB) + Filter loss(dB) + Attenuator loss(dB)
2. Level(dBμV/m) = Antenna Factor(dB/m) + Path Loss(dB) + Read Level(dBμV) - Preamp Factor(dB)
3. Over Limit(dB) = Level(dBμV/m) – Limit Line(dBμV/m)

For Peak Limit @ 2390MHz:

1. Level(dBμV/m)
= Antenna Factor(dB/m) + Path Loss(dB) + Read Level(dBμV) - Preamp Factor(dB)
= 32.22(dB/m) + 4.58(dB) + 54.51(dBμV) – 35.86 (dB)
= 55.45 (dBμV/m)
2. Over Limit(dB)
= Level(dBμV/m) – Limit Line(dBμV/m)
= 55.45(dBμV/m) – 74(dBμV/m)
= -18.55(dB)

For Average Limit @ 2390MHz:

1. Level(dBμV/m)
= Antenna Factor(dB/m) + Path Loss(dB) + Read Level(dBμV) - Preamp Factor(dB)
= 32.22(dB/m) + 4.58(dB) + 42.6(dBμV) – 35.86 (dB)
= 43.54 (dBμV/m)
2. Over Limit(dB) = Level(dBμV/m) – Limit Line(dBμV/m)
= 43.54(dBμV/m) – 54(dBμV/m)
= -10.46(dB)

Both peak and average measured complies with the limit line, so test result is “PASS”.



Appendix D. Radiated Spurious Emission Plots

Test Engineer :	Watt Tseng, Karl Hou, and BigShow Wang	Temperature :	23~26°C
		Relative Humidity :	50~57%

Note symbol

-L	Low channel location
-R	High channel location



Band 1 - 5150~5250MHz
WIFI 802.11a (Band Edge @ 3m)

WIFI	Band 1 5150~5250MHz Band Edge @ 3m	
ANT	802.11a CH36 5180MHz	
1	Horizontal	Fundamental
Peak	<p>Site : 03CH15-HY Condition : PEAK_BE_74 3m 91200_15_1620 HORIZONTAL Detector : Peak Project : 942629 Mode : 1</p>	<p>Site : 03CH15-HY Condition : PEAK(LINE) 3m 91200_15_1620 HORIZONTAL Detector : Peak Project : 942629 Mode : 1</p>
Avg.	<p>Site : 03CH15-HY Condition : AV6_BE_54 3m 91200_15_1620 HORIZONTAL Detector : Peak Project : 942629 Mode : 1</p>	Left blank

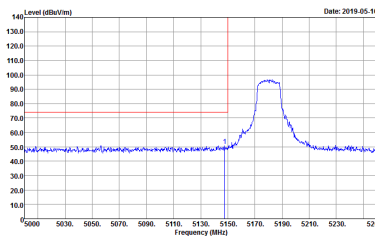
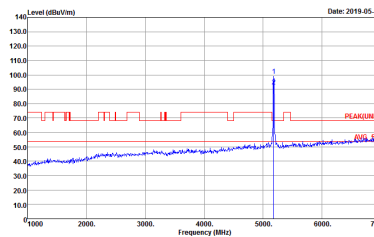
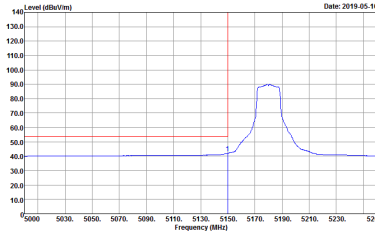

WIFI	Band 1 5150~5250MHz Band Edge @ 3m	
ANT	802.11a CH36 5180MHz	
1	Vertical	Fundamental
Peak	 <p>Date: 2019-05-10</p> <p>Site : 03CH15-HY Condition : PEAK_BE_74 3m 91200_15_1620 VERTICAL : RBW:1000.000KHz VBW:3000.000KHz SWT:Auto Detector : Peak Project : 942629 Mode : 1</p>	 <p>Date: 2019-05-10</p> <p>Site : 03CH15-HY Condition : PEAK(LINII) 3m 91200_15_1620 VERTICAL : RBW:1000.000KHz VBW:3000.000KHz SWT:Auto Detector : Peak Project : 942629 Mode : 1</p>
Avg.	 <p>Date: 2019-05-10</p> <p>Site : 03CH15-HY Condition : AVG_BE_54 3m 91200_15_1620 VERTICAL : RBW:1000.000KHz VBW:0.010KHz SWT:Auto Detector : Peak Project : 942629 Mode : 1</p>	Left blank

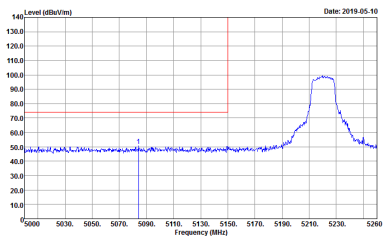
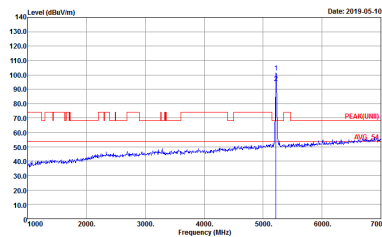
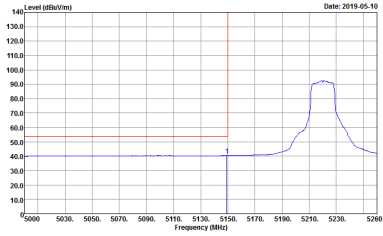

WIFI	Band 1 5150~5250MHz Band Edge @ 3m	
ANT	802.11a CH44 5220MHz - L	
1	Horizontal	Fundamental
Peak	 <p>Date: 2019-05-10</p> <p>Site : 03CH15-HY Condition : PEAK_BE_74 3m 91200_15_1620 HORIZONTAL RBW:1000.000KHz VBW:3000.000KHz SWT:Auto Detector : Peak Project : 942629 Mode : 2</p>	 <p>Date: 2019-05-10</p> <p>Site : 03CH15-HY Condition : PEAK(UNII) 3m 91200_15_1620 HORIZONTAL RBW:1000.000KHz VBW:3000.000KHz SWT:Auto Detector : Peak Project : 942629 Mode : 2</p>
Avg.	 <p>Date: 2019-05-10</p> <p>Site : 03CH15-HY Condition : AVG_BE_54 3m 91200_15_1620 HORIZONTAL RBW:1000.000KHz VBW:3000.000KHz SWT:Auto Detector : Peak Project : 942629 Mode : 2</p>	Left blank

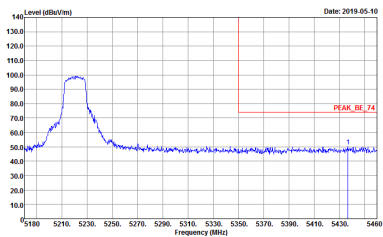
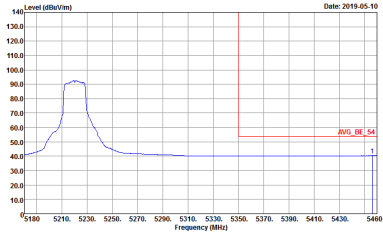

WIFI	Band 1 5150~5250MHz Band Edge @ 3m	
ANT	802.11a CH44 5220MHz - R	
1	Horizontal	Fundamental
<p>Peak</p>	 <p>Site : 03CH15-HY Condition : PEAK_BE_74 3m 9120D_15_1620 HORIZONTAL Detector : Peak Project : 942629 Mode : Z</p>	<p>Left blank</p>
<p>Avg.</p>	 <p>Site : 03CH15-HY Condition : AVG_BE_54 3m 9120D_15_1620 HORIZONTAL Detector : Peak Project : 942629 Mode : Z</p>	<p>Left blank</p>

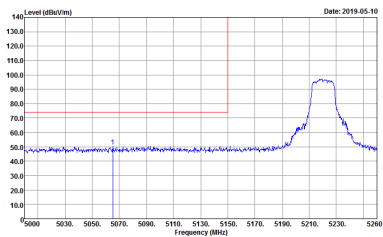
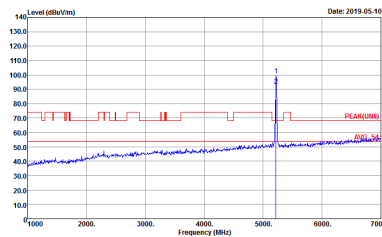
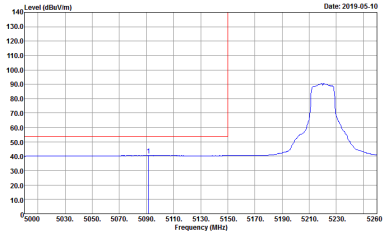

WIFI	Band 1 5150~5250MHz Band Edge @ 3m	
ANT	802.11a CH44 5220MHz - L	
1	Vertical	Fundamental
Peak	 <p>Date: 2019-05-10</p> <p>Site : 03CH15-HY Condition : PEAK_BE_74 3m 91200_15_1620 VERTICAL : RBW:1000.000KHz VBW:3000.000KHz SWT:Auto Detector : Peak Project : 942629 Mode : 2</p>	 <p>Date: 2019-05-10</p> <p>Site : 03CH15-HY Condition : PEAK(UNII) 3m 91200_15_1620 VERTICAL : RBW:1000.000KHz VBW:3000.000KHz SWT:Auto Detector : Peak Project : 942629 Mode : 2</p>
Avg.	 <p>Date: 2019-05-10</p> <p>Site : 03CH15-HY Condition : AVG_BE_54 3m 91200_15_1620 VERTICAL : RBW:1000.000KHz VBW:0.010KHz SWT:Auto Detector : Peak Project : 942629 Mode : 2</p>	Left blank



WIFI	Band 1 5150~5250MHz Band Edge @ 3m	
ANT	802.11a CH44 5220MHz - R	
1	Vertical	Fundamental
Peak	<p>Site : 03CH15-HY Condition : PEAK_BE_74 3m 9120D_15_1620 VERTICAL Detector : Peak Project : 942629 Mode : 2</p>	Left blank
Avg.	<p>Site : 03CH15-HY Condition : AVG_BE_54 3m 9120D_15_1620 VERTICAL Detector : Peak Project : 942629 Mode : 2</p>	Left blank



WIFI	Band 1 5150~5250MHz Band Edge @ 3m	
ANT	802.11a CH48 5240MHz - L	
1	Horizontal	Fundamental
Peak	<p>Site : 03CH15-HY Condition : PEAK_BE_74 3m 91200_15_1620 HORIZONTAL Detector : Peak Project : 942629 Mode : 3</p>	<p>Site : 03CH15-HY Condition : PEAK(LINII) 3m 91200_15_1620 HORIZONTAL Detector : Peak Project : 942629 Mode : 3</p>
Avg.	<p>Site : 03CH15-HY Condition : AVG_BE_54 3m 91200_15_1620 HORIZONTAL Detector : Peak Project : 942629 Mode : 3</p>	Left blank

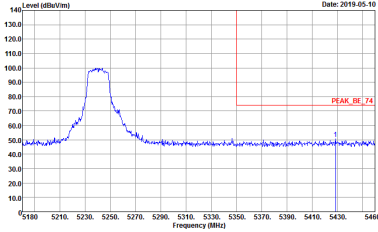
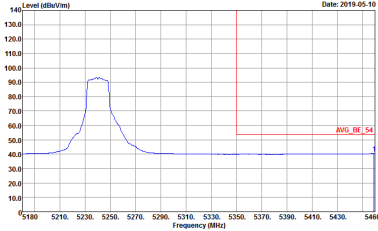

WIFI	Band 1 5150~5250MHz Band Edge @ 3m	
ANT	802.11a CH48 5240MHz - R	
1	Horizontal	Fundamental
Peak	 <p>Site : 03CH15-HY Condition : PEAK_BE_74 3m 91200_15_1620 HORIZONTAL Detector : Peak Project : 942629 Mode : 3</p>	Left blank
Avg.	 <p>Site : 03CH15-HY Condition : AVG_BE_54 3m 91200_15_1620 HORIZONTAL Detector : Peak Project : 942629 Mode : 3</p>	Left blank



WIFI	Band 1 5150~5250MHz Band Edge @ 3m	
ANT	802.11a CH48 5240MHz - L	
1	Vertical	Fundamental
<p>Peak</p>	<p>Site : 03CH15-HY Condition : PEAK_BE_74 3m 91200_15_1620 VERTICAL : RBW:1000.000KHz VBW:3000.000KHz SWT:Auto Detector : Peak Project : 942629 Mode : 3</p>	<p>Site : 03CH15-HY Condition : PEAK(UNII) 3m 91200_15_1620 VERTICAL : RBW:1000.000KHz VBW:3000.000KHz SWT:Auto Detector : Peak Project : 942629 Mode : 3</p>
<p>Avg.</p>	<p>Site : 03CH15-HY Condition : AVG_BE_54 3m 91200_15_1620 VERTICAL : RBW:1000.000KHz VBW:0.010KHz SWT:Auto Detector : Peak Project : 942629 Mode : 3</p>	<p>Left blank</p>



WIFI	Band 1 5150~5250MHz Band Edge @ 3m	
ANT	802.11a CH48 5240MHz - R	
1	Vertical	Fundamental
Peak	<p>Site : 03CH15-HY Condition : PEAK_BE_74 3m 9120D_15_1620 VERTICAL Detector : Peak Project : 942629 Mode : 3</p>	Left blank
Avg.	<p>Site : 03CH15-HY Condition : AVG_BE_54 3m 9120D_15_1620 VERTICAL Detector : Peak Project : 942629 Mode : 3</p>	Left blank

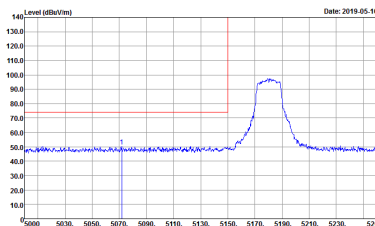
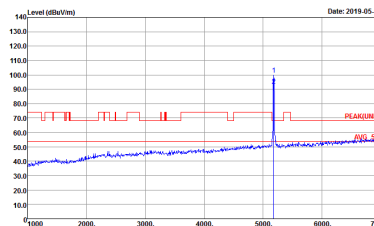
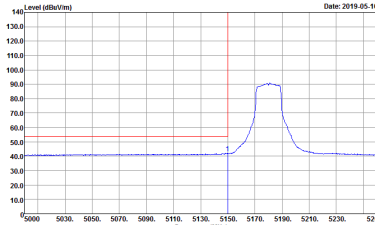

Band 1 5150~5250MHz
WIFI 802.11n HT20 (Band Edge @ 3m)

WIFI	Band 1 5150~5250MHz Band Edge @ 3m	
ANT	802.11n HT20 CH36 5180MHz	
1	Horizontal	Fundamental
<p align="center">Peak</p>	 <p>Site : 03CH15-1Y Condition : PEAK_BE_74 3m 91200_15_1620 HORIZONTAL RBW:1000.000KHz VBW:3000.000KHz SWT:Auto Detector : Peak Project : 942629 Mode : 4</p>	 <p>Site : 03CH15-1Y Condition : PEAK(UNIT) 3m 91200_15_1620 HORIZONTAL RBW:1000.000KHz VBW:3000.000KHz SWT:Auto Detector : Peak Project : 942629 Mode : 4</p>
<p align="center">Avg.</p>	 <p>Site : 03CH15-1Y Condition : AVG_BE_54 3m 91200_15_1620 HORIZONTAL RBW:1000.000KHz VBW:1.000KHz SWT:Auto Detector : Peak Project : 942629 Mode : 4</p>	<p align="center">Left blank</p>

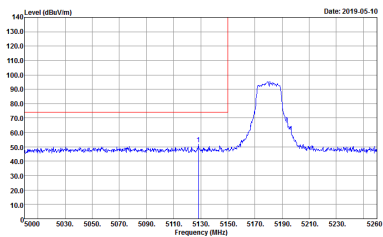
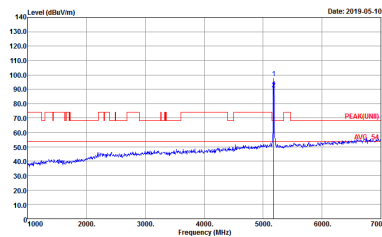
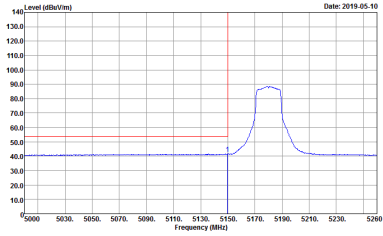

WIFI	Band 1 5150~5250MHz Band Edge @ 3m	
ANT	802.11n HT20 CH36 5180MHz	
1	Vertical	Fundamental
Peak	 <p>Site : 03CH15-HY Condition : PEAK_BE_74 3m 91200_15_1620 VERTICAL Detector : Peak Project : 942629 Mode : 4</p>	 <p>Site : 03CH15-HY Condition : PEAK(LINII) 3m 91200_15_1620 VERTICAL Detector : Peak Project : 942629 Mode : 4</p>
Avg.	 <p>Site : 03CH15-HY Condition : AVG_BE_54 3m 91200_15_1620 VERTICAL Detector : Peak Project : 942629 Mode : 4</p>	Left blank

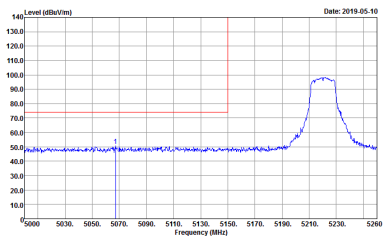
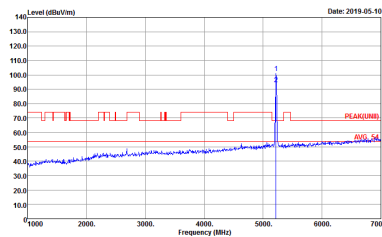
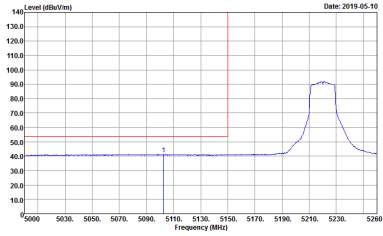

WIFI	Band 1 5150~5250MHz Band Edge @ 3m	
ANT	802.11n HT20 CH44 5220MHz - L	
1	Horizontal	Fundamental
<p>Peak</p>	 <p>Date: 2019-05-10</p> <p>Site : 03CH15-HY Condition : PEAK_BE_74 3m 91200_15_1620 HORIZONTAL RBW:1000.000KHz VBW:3000.000KHz SWT:Auto Detector : Peak Project : 942629 Mode : 5</p>	 <p>Date: 2019-05-10</p> <p>Site : 03CH15-HY Condition : PEAK(UNII) 3m 91200_15_1620 HORIZONTAL RBW:1000.000KHz VBW:3000.000KHz SWT:Auto Detector : Peak Project : 942629 Mode : 5</p>
<p>Avg.</p>	 <p>Date: 2019-05-10</p> <p>Site : 03CH15-HY Condition : AVG_BE_54 3m 91200_15_1620 HORIZONTAL RBW:1000.000KHz VBW:1000KHz SWT:Auto Detector : Peak Project : 942629 Mode : 5</p>	<p>Left blank</p>

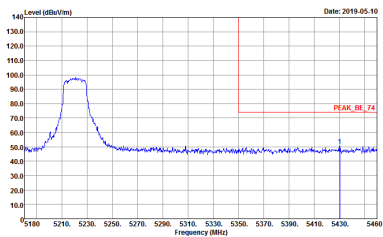
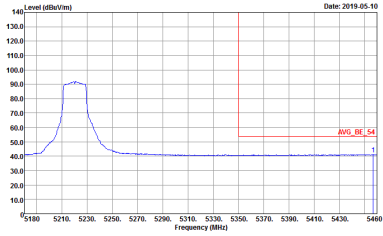

WIFI	Band 1 5150~5250MHz Band Edge @ 3m	
ANT	802.11n HT20 CH44 5220MHz - R	
1	Horizontal	Fundamental
<p>Peak</p>	 <p>Site : 03CH15-HY Condition : PEAK_BE_74 3m 9120D_15_1620 HORIZONTAL Detector : Peak Project : 942629 Mode : 5</p>	<p>Left blank</p>
<p>Avg.</p>	 <p>Site : 03CH15-HY Condition : AVG_BE_54 3m 9120D_15_1620 HORIZONTAL Detector : Peak Project : 942629 Mode : 5</p>	<p>Left blank</p>

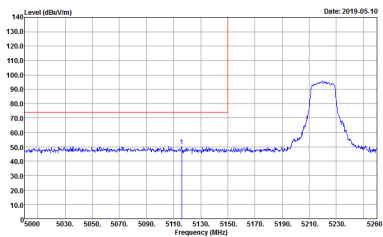
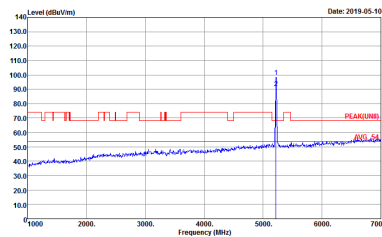

WIFI	Band 1 5150~5250MHz Band Edge @ 3m	
ANT	802.11n HT20 CH44 5220MHz - L	
1	Vertical	Fundamental
Peak	 <p>Date: 2019-05-10</p> <p>Site : 03CH15-HY Condition : PEAK_BE_74 3m 91200_15_1620 VERTICAL : RBW:1000.000KHz VBW:3000.000KHz SWT:Auto Detector : Peak Project : 942629 Mode : 5</p>	 <p>Date: 2019-05-10</p> <p>Site : 03CH15-HY Condition : PEAK(UNII) 3m 91200_15_1620 VERTICAL : RBW:1000.000KHz VBW:3000.000KHz SWT:Auto Detector : Peak Project : 942629 Mode : 5</p>
Avg.	 <p>Date: 2019-05-10</p> <p>Site : 03CH15-HY Condition : AVG_BE_54 3m 91200_15_1620 VERTICAL : RBW:1000.000KHz VBW:1000KHz SWT:Auto Detector : Peak Project : 942629 Mode : 5</p>	Left blank

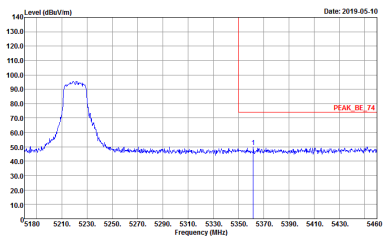
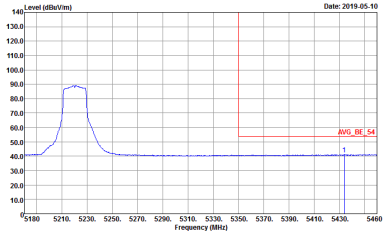

WIFI	Band 1 5150~5250MHz Band Edge @ 3m	
ANT	802.11n HT20 CH44 5220MHz - R	
1	Vertical	Fundamental
Peak	 <p>Site : 03CH15-HY Condition : PEAK_BE_74 3m 9120D_15_1620 VERTICAL Detector : Peak Project : 942629 Mode : 5</p>	Left blank
Avg.	 <p>Site : 03CH15-HY Condition : AVG_BE_54 3m 9120D_15_1620 VERTICAL Detector : Peak Project : 942629 Mode : 5</p>	Left blank

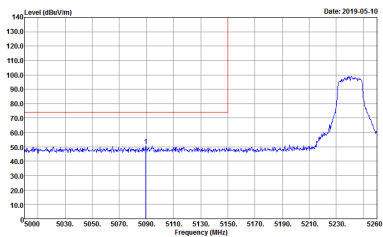
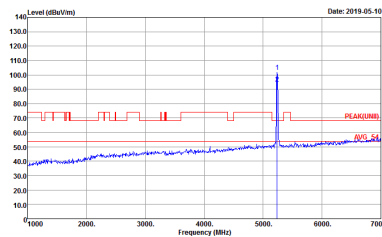
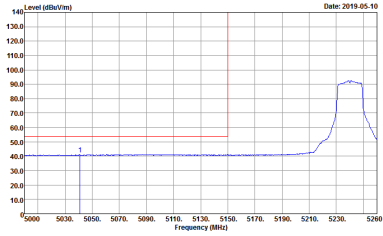

WIFI	Band 1 5150~5250MHz Band Edge @ 3m	
ANT	802.11n HT20 CH48 5240MHz - L	
1	Horizontal	Fundamental
Peak	 <p>Date: 2019-05-10</p> <p>Site : 03CH15-HY Condition : PEAK_BE_74 3m 91200_15_1620 HORIZONTAL RBW:1000.000KHz VBW:3000.000KHz SWT:Auto Detector : Peak Project : 942629 Mode : 6</p>	 <p>Date: 2019-05-10</p> <p>Site : 03CH15-HY Condition : PEAK(UNII) 3m 91200_15_1620 HORIZONTAL RBW:1000.000KHz VBW:3000.000KHz SWT:Auto Detector : Peak Project : 942629 Mode : 6</p>
Avg.	 <p>Date: 2019-05-10</p> <p>Site : 03CH15-HY Condition : AVG_BE_54 3m 91200_15_1620 HORIZONTAL RBW:1000.000KHz VBW:1000KHz SWT:Auto Detector : Peak Project : 942629 Mode : 6</p>	Left blank

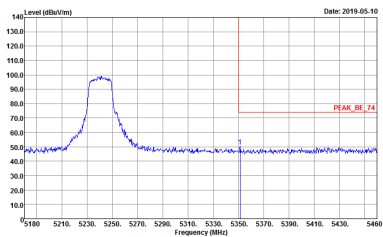
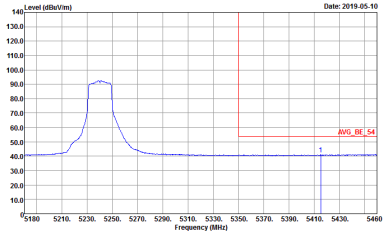

WIFI	Band 1 5150~5250MHz Band Edge @ 3m	
ANT	802.11n HT20 CH48 5240MHz - R	
1	Horizontal	Fundamental
<p>Peak</p>	 <p>Site : 03CH15-HY Condition : PEAK_BE_74 3m 9120D_15_1620 HORIZONTAL Detector : Peak Project : 942629 Mode : G</p>	<p>Left blank</p>
<p>Avg.</p>	 <p>Site : 03CH15-HY Condition : AVG_BE_54 3m 9120D_15_1620 HORIZONTAL Detector : Peak Project : 942629 Mode : G</p>	<p>Left blank</p>



WIFI	Band 1 5150~5250MHz Band Edge @ 3m	
ANT	802.11n HT20 CH48 5240MHz - L	
1	Vertical	Fundamental
<p>Peak</p>	<p>Site : 03CH15-HY Condition : PEAK_BE_74 3m 91200_15_1620 VERTICAL Detector : Peak Project : 942629 Mode : 6</p>	<p>Site : 03CH15-HY Condition : PEAK(LINII) 3m 91200_15_1620 VERTICAL Detector : Peak Project : 942629 Mode : 6</p>
<p>Avg.</p>	<p>Site : 03CH15-HY Condition : AVG_BE_54 3m 91200_15_1620 VERTICAL Detector : Peak Project : 942629 Mode : 6</p>	<p>Left blank</p>

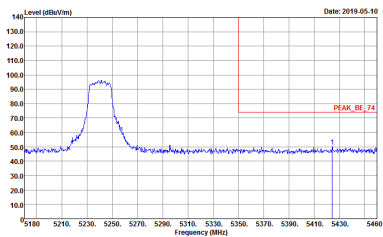
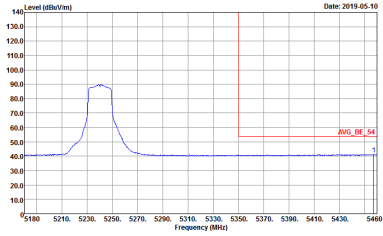

WIFI	Band 1 5150~5250MHz Band Edge @ 3m	
ANT	802.11n HT20 CH48 5240MHz - R	
1	Vertical	Fundamental
Peak	 <p>Site : 03CH15-HY Condition : PEAK_BE_74 3m 9120D_15_1620 VERTICAL Detector : Peak Project : 942629 Mode : G</p>	Left blank
Avg.	 <p>Site : 03CH15-HY Condition : AVG_BE_54 3m 9120D_15_1620 VERTICAL Detector : Peak Project : 942629 Mode : G</p>	Left blank



**Band 1 5150~5250MHz
WIFI 802.11n HT40 (Band Edge @ 3m)**

WIFI	Band 1 5150~5250MHz Band Edge @ 3m	
ANT	802.11n HT40 CH38 5190MHz - L	
1	Horizontal	Fundamental
<p align="center">Peak</p>	<p>Site : 03CH15-HY Condition : PEAK_BE_74 3m 91200_15_1620 HORIZONTAL RBW:1000.000KHz VBW:3000.000KHz SWT:Auto Detector : Peak Project : 942629 Mode : 7 Setting : 14</p>	<p>Site : 03CH15-HY Condition : PEAK(UNIT) 3m 91200_15_1620 HORIZONTAL RBW:1000.000KHz VBW:3000.000KHz SWT:Auto Detector : Peak Project : 942629 Mode : 7 Setting : 14</p>
<p align="center">Avg.</p>	<p>Site : 03CH15-HY Condition : AVG_BE_54 3m 91200_15_1620 HORIZONTAL RBW:1000.000KHz VBW:3.000KHz SWT:Auto Detector : Peak Project : 942629 Mode : 7 Setting : 14</p>	<p align="center">Left blank</p>

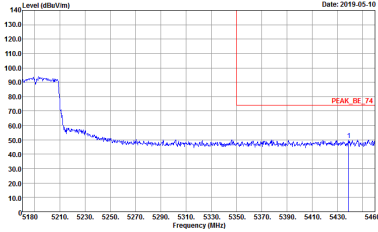
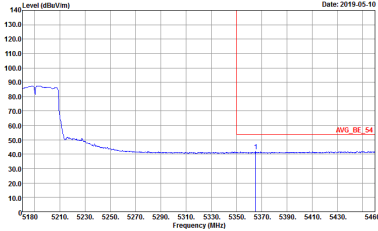

WIFI	Band 1 5150~5250MHz Band Edge @ 3m	
ANT	802.11n HT40 CH38 5190MHz - R	
1	Horizontal	Fundamental
<p>Peak</p>	 <p>Site : 03CH15-HY Condition : PEAK_BE_74 3m 91200_15_1620 HORIZONTAL RBW:1000.000KHz VBW:3000.000KHz SWT:Auto Detector : Peak Project : 942629 Mode : 7 Setting : 14</p>	<p>Left blank</p>
<p>Avg.</p>	 <p>Site : 03CH15-HY Condition : AVG_BE_54 3m 91200_15_1620 HORIZONTAL RBW:1000.000KHz VBW:3.000KHz SWT:Auto Detector : Peak Project : 942629 Mode : 7 Setting : 14</p>	<p>Left blank</p>



WIFI	Band 1 5150~5250MHz Band Edge @ 3m	
ANT	802.11n HT40 CH38 5190MHz - L	
1	Vertical	Fundamental
<p>Peak</p>	<p>Site : 03CH15-HY Condition : PEAK_BE_74 3m 91200_15_1620 VERTICAL Detector : Peak Project : 942629 Mode : 7 Setting : 14</p>	<p>Site : 03CH15-HY Condition : PEAK(LIMB) 3m 91200_15_1620 VERTICAL Detector : Peak Project : 942629 Mode : 7 Setting : 14</p>
<p>Avg.</p>	<p>Site : 03CH15-HY Condition : AVG_BE_54 3m 91200_15_1620 VERTICAL Detector : Peak Project : 942629 Mode : 7 Setting : 14</p>	<p>Left blank</p>

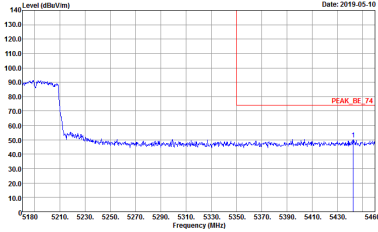
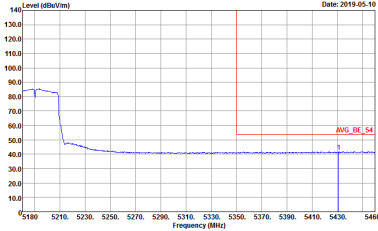

WIFI	Band 1 5150~5250MHz Band Edge @ 3m	
ANT	802.11n HT40 CH38 5190MHz - R	
1	Vertical	Fundamental
<p>Peak</p>	 <p>Site : 03CH15-HY Condition : PEAK_BE_74 3m 9120D_15_1620 VERTICAL Detector : Peak Project : 942629 Mode : 7 Setting : 14</p>	<p>Left blank</p>
<p>Avg.</p>	 <p>Site : 03CH15-HY Condition : AVG_BE_54 3m 9120D_15_1620 VERTICAL Detector : Peak Project : 942629 Mode : 7 Setting : 14</p>	<p>Left blank</p>



WIFI	Band 1 5150~5250MHz Band Edge @ 3m	
ANT	802.11n HT40 CH46 5230MHz - L	
1	Horizontal	Fundamental
<p>Peak</p>	<p>Site : 03CH15-HY Condition : PEAK_BE_74 3m 91200_15_1620 HORIZONTAL Detector : Peak Project : 942629 Mode : B</p>	<p>Site : 03CH15-HY Condition : PEAK(LINII) 3m 91200_15_1620 HORIZONTAL Detector : Peak Project : 942629 Mode : B</p>
<p>Avg.</p>	<p>Site : 03CH15-HY Condition : AVG_BE_54 3m 91200_15_1620 HORIZONTAL Detector : Peak Project : 942629 Mode : B</p>	<p>Left blank</p>

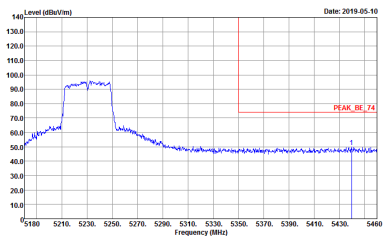
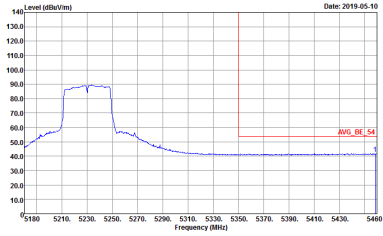

WIFI	Band 1 5150~5250MHz Band Edge @ 3m	
ANT	802.11n HT40 CH46 5230MHz - R	
1	Horizontal	Fundamental
Peak	 <p>Site : 03CH15-HY Condition : PEAK_BE_74 3m 91200_15_1620 HORIZONTAL Detector : Peak Project : 942629 Mode : B</p>	Left blank
Avg.	 <p>Site : 03CH15-HY Condition : AVG_BE_54 3m 91200_15_1620 HORIZONTAL Detector : Peak Project : 942629 Mode : B</p>	Left blank

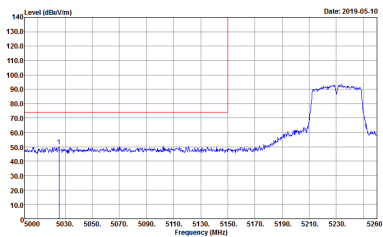
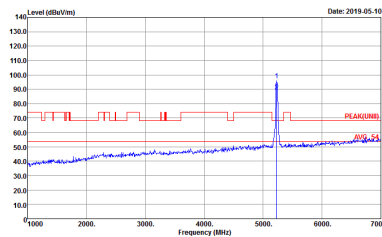
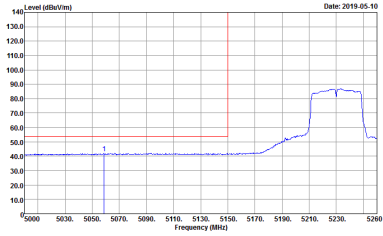

WIFI	Band 1 5150~5250MHz Band Edge @ 3m	
ANT	802.11n HT40 CH46 5230MHz - L	
1	Vertical	Fundamental
<p>Peak</p>	 <p>Site : 03CH15-HY Condition : PEAK_BE_74 3m 91200_15_1620 VERTICAL Detector : Peak Project : 942629 Mode : B</p>	 <p>Site : 03CH15-HY Condition : PEAK(LINII) 3m 91200_15_1620 VERTICAL Detector : Peak Project : 942629 Mode : B</p>
<p>Avg.</p>	 <p>Site : 03CH15-HY Condition : AVG_BE_54 3m 91200_15_1620 VERTICAL Detector : Peak Project : 942629 Mode : B</p>	<p>Left blank</p>



WIFI	Band 1 5150~5250MHz Band Edge @ 3m	
ANT	802.11n HT40 CH46 5230MHz - R	
1	Vertical	Fundamental
Peak	<p>Site : 03CH15-HY Condition : PEAK_BE_74 3m 9120D_15_1620 VERTICAL Detector : Peak Project : 942629 Mode : B</p>	Left blank
Avg.	<p>Site : 03CH15-HY Condition : AVG_BE_54 3m 9120D_15_1620 VERTICAL Detector : Peak Project : 942629 Mode : B</p>	Left blank

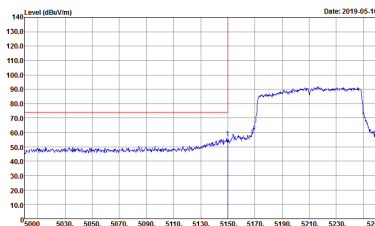
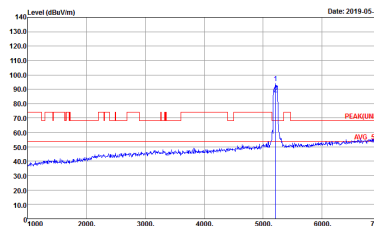
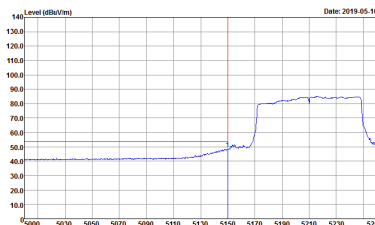

Band 1 5150~5250MHz
WIFI 802.11ac VHT80 (Band Edge @ 3m)

WIFI	Band 1 5150~5250MHz Band Edge @ 3m	
ANT	802.11ac VHT80 CH42 5210MHz - L	
1	Horizontal	Fundamental
<p align="center">Peak</p>	 <p>Site : 03CH15-1Y Condition : PEAK_BE_74 3m 91200_15_1620 HORIZONTAL RBW:1000.000KHz VBW:3000.000KHz SWT:Auto Detector : Peak Project : 942629 Mode : 9</p>	 <p>Site : 03CH15-1Y Condition : PEAK(UNIT) 3m 91200_15_1620 HORIZONTAL RBW:1000.000KHz VBW:3000.000KHz SWT:Auto Detector : Peak Project : 942629 Mode : 9</p>
<p align="center">Avg.</p>	 <p>Site : 03CH15-1Y Condition : AVG_BE_54 3m 91200_15_1620 HORIZONTAL RBW:1000.000KHz VBW:3.000KHz SWT:Auto Detector : Peak Project : 942629 Mode : 9</p>	<p align="center">Left blank</p>

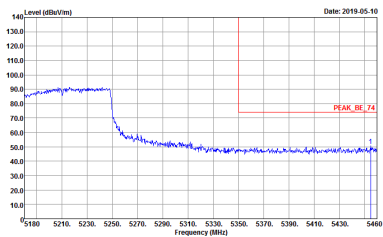
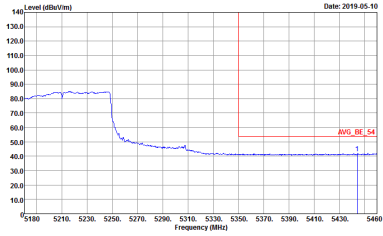

WIFI	Band 1 5150~5250MHz Band Edge @ 3m	
ANT	802.11ac VHT80 CH42 5210MHz - R	
1	Horizontal	Fundamental
<p>Peak</p>	 <p>Site : 03CH15-HY Condition : PEAK_BE_74 3m 91200_15_1620 HORIZONTAL Detector : Peak Project : 942629 Mode : 9</p>	<p>Left blank</p>
<p>Avg.</p>	 <p>Site : 03CH15-HY Condition : AVG_BE_54 3m 91200_15_1620 HORIZONTAL Detector : Peak Project : 942629 Mode : 9</p>	<p>Left blank</p>

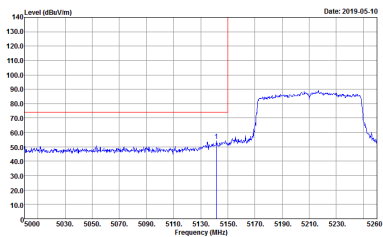
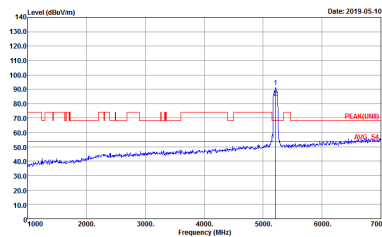
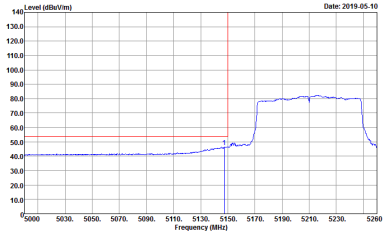

WIFI	Band 1 5150~5250MHz Band Edge @ 3m	
ANT	802.11ac VHT80 CH42 5210MHz - L	
1	Vertical	Fundamental
Peak	 <p>Site : 03CH15-HY Condition : PEAK_BE_74 3m 91200_15_1620 VERTICAL Detector : Peak Project : 942629 Mode : 9</p>	 <p>Site : 03CH15-HY Condition : PEAK(LINII) 3m 91200_15_1620 VERTICAL Detector : Peak Project : 942629 Mode : 9</p>
Avg.	 <p>Site : 03CH15-HY Condition : AVG_BE_54 3m 91200_15_1620 VERTICAL Detector : Peak Project : 942629 Mode : 9</p>	Left blank



WIFI	Band 1 5150~5250MHz Band Edge @ 3m	
ANT	802.11ac VHT80 CH42 5210MHz - R	
1	Vertical	Fundamental
Peak	<p>Site : 03CH15-HY Condition : PEAK_BE_74 3m 9120D_15_1620 VERTICAL Detector : Peak Project : 942629 Mode : 9</p>	Left blank
Avg.	<p>Site : 03CH15-HY Condition : AVG_BE_54 3m 9120D_15_1620 VERTICAL Detector : Peak Project : 942629 Mode : 9</p>	Left blank



Band 1 - 5150~5250MHz
WIFI 802.11a (Harmonic @ 3m)

WIFI	Band 1 5150~5250MHz Harmonic @ 3m	
ANT	802.11a CH36 5180MHz	
1	Horizontal	Vertical
Peak Avg.	<p>Site : 03CH15-11Y Condition : PEAK(LINE) 3m 9120D_15_1620 HORIZONTAL Detector : Peak Project : 942629 Mode : -1</p>	<p>Site : 03CH15-11Y Condition : PEAK(LINE) 3m 9120D_15_1620 VERTICAL Detector : Peak Project : 942629 Mode : -1</p>

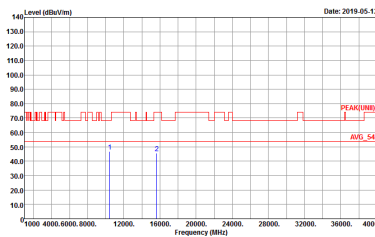
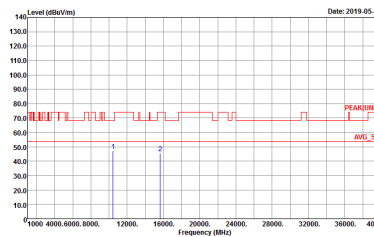

WIFI	Band 1 5150~5250MHz Harmonic @ 3m	
ANT	802.11a CH44 5220MHz	
1	Horizontal	Vertical
<p>Peak</p> <p>Avg.</p>	 <p>Site : 03CH15-11Y Condition : PEAK(LINE1) 3m 9120D_15_1620 HORIZONTAL Detector : Peak Project : 942629 Mode : Z</p>	 <p>Site : 03CH15-11Y Condition : PEAK(LINE1) 3m 9120D_15_1620 VERTICAL Detector : Peak Project : 942629 Mode : Z</p>

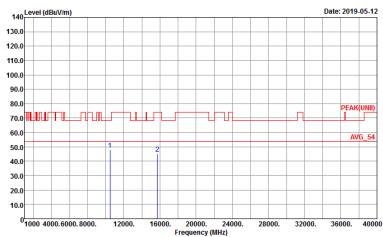
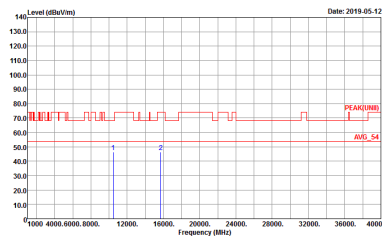

WIFI	Band 1 5150~5250MHz Harmonic @ 3m	
ANT	802.11a CH48 5240MHz	
1	Horizontal	Vertical
<p>Peak</p> <p>Avg.</p>	 <p>Site : 03CH15-11Y Condition : PEAK(LINE1) 3m 9120D_15_1620 HORIZONTAL Detector : Peak Project : 942629 Mode : 3</p>	 <p>Site : 03CH15-11Y Condition : PEAK(LINE1) 3m 9120D_15_1620 VERTICAL Detector : Peak Project : 942629 Mode : 3</p>



Band 1 5150~5250MHz
WIFI 802.11n HT20 (Harmonic @ 3m)

WIFI	Band 1 5150~5250MHz Harmonic @ 3m	
ANT	802.11n HT20 CH36 5180MHz	
1	Horizontal	Vertical
<p>Peak</p> <p>Avg.</p>	<p>Site : 03CH15-11Y Condition : PEAK(LINE) 3m 9120D_15_1620 HORIZONTAL Detector : Peak Project : 942629 Mode : -4</p>	<p>Site : 03CH15-11Y Condition : PEAK(LINE) 3m 9120D_15_1620 VERTICAL Detector : Peak Project : 942629 Mode : -4</p>

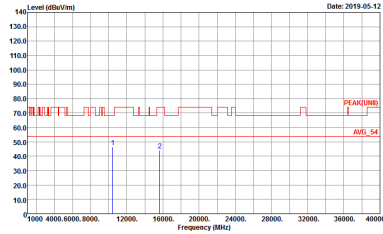
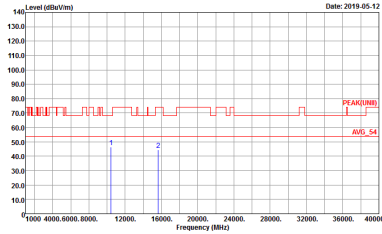

WIFI	Band 1 5150~5250MHz Harmonic @ 3m	
ANT	802.11n HT20 CH44 5220MHz	
1	Horizontal	Vertical
<p>Peak</p> <p>Avg.</p>	 <p>Site : 03CH15-11Y Condition : PEAK(LINEI) 3m 9120D_15_1620 HORIZONTAL Detector : Peak Project : 942629 Mode : -5</p>	 <p>Site : 03CH15-11Y Condition : PEAK(LINEI) 3m 9120D_15_1620 VERTICAL Detector : Peak Project : 942629 Mode : -5</p>

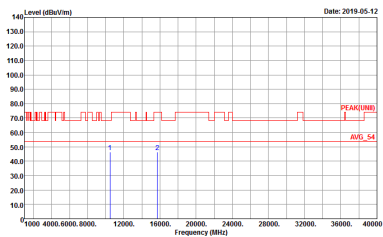
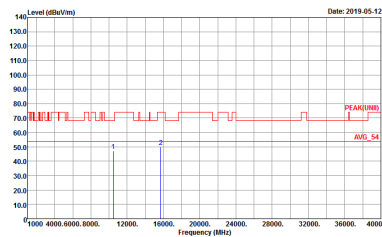

WIFI	Band 1 5150~5250MHz Harmonic @ 3m	
ANT	802.11n HT20 CH48 5240MHz	
1	Horizontal	Vertical
<p>Peak</p> <p>Avg.</p>	 <p>Site : 03CH15-11Y Condition : PEAK(LINE1) 3m 9120D_15_1620 HORIZONTAL Detector : Peak Project : 942629 Mode : -6</p>	 <p>Site : 03CH15-11Y Condition : PEAK(LINE1) 3m 9120D_15_1620 VERTICAL Detector : Peak Project : 942629 Mode : -6</p>



Band 1 5150~5250MHz
WIFI 802.11n HT40 (Harmonic @ 3m)

WIFI	Band 1 5150~5250MHz Harmonic @ 3m	
ANT	802.11n HT40 CH38 5190MHz	
1	Horizontal	Vertical
Peak Avg.	<p>Site : 03CH15-HY Condition : PEAK(LINII) 3m 91200_15_1620 HORIZONTAL Detector : Peak Project : 942629 Mode : 7</p>	<p>Site : 03CH15-HY Condition : PEAK(LINII) 3m 91200_15_1620 VERTICAL Detector : Peak Project : 942629 Mode : 7</p>

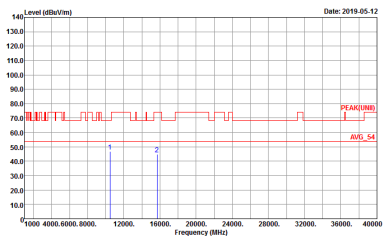
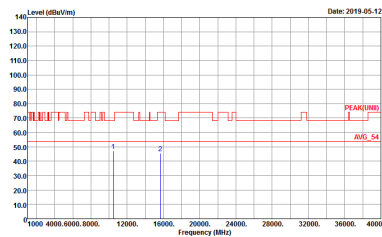

WIFI	Band 1 5150~5250MHz Harmonic @ 3m	
ANT	802.11n HT40 CH46 5230MHz	
1	Horizontal	Vertical
<p>Peak</p> <p>Avg.</p>	 <p>Site : 03CH15-11Y Condition : PEAK(LINE1) 3m 9120D_15_1620 HORIZONTAL Detector : Peak Project : 942629 Mode : S</p>	 <p>Site : 03CH15-11Y Condition : PEAK(LINE1) 3m 9120D_15_1620 VERTICAL Detector : Peak Project : 942629 Mode : S</p>



**Band 1 5150~5250MHz
WIFI 802.11ac VHT80 (Harmonic @ 3m)**

WIFI	Band 1 5150~5250MHz Harmonic @ 3m	
ANT	802.11ac VHT80 CH42 5210MHz	
1	Horizontal	Vertical
Peak Avg.	<p>Site : 03CH15-HY Condition : PEAK(LINII) 3m 91200_15_1620 HORIZONTAL Detector : Peak Project : 942629 Mode : 9</p>	<p>Site : 03CH15-HY Condition : PEAK(LINII) 3m 91200_15_1620 VERTICAL Detector : Peak Project : 942629 Mode : 9</p>



Band 2 - 5250~5350MHz
WIFI 802.11a (Band Edge @ 3m)

WIFI	Band 2 5250~5350MHz Band Edge @ 3m	
ANT	802.11a CH52 5260MHz - L	
1	Horizontal	Fundamental
Peak	<p>Site : 03CH15-HY Condition : PEAK_BE_74 3m 91200_15_1620 HORIZONTAL RBW:1000.000KHz VBW:3000.000KHz SWT:Auto Detector : Peak Project : 942629 Mode : ID</p>	<p>Site : 03CH15-HY Condition : PEAK(FUNDET) 3m 91200_15_1620 HORIZONTAL RBW:1000.000KHz VBW:3000.000KHz SWT:Auto Detector : Peak Project : 942629 Mode : ID</p>
Avg.	<p>Site : 03CH15-HY Condition : AV6_BE_54 3m 91200_15_1620 HORIZONTAL RBW:1000.000KHz VBW:0.010KHz SWT:Auto Detector : Peak Project : 942629 Mode : ID</p>	Left blank

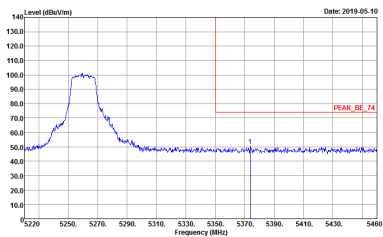
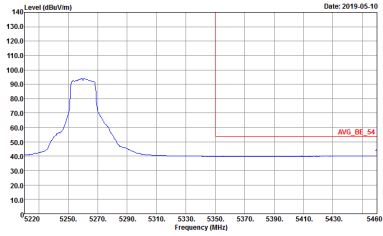

WIFI	Band 2 5250~5350MHz Band Edge @ 3m	
ANT	802.11a CH52 5260MHz - R	
1	Horizontal	Fundamental
<p>Peak</p>	 <p>Site : 03CH15-HY Condition : PEAK_BE_74 3m 91200_15_1620 HORIZONTAL Detector : Peak Project : 942629 Mode : ID</p>	<p>Left blank</p>
<p>Avg.</p>	 <p>Site : 03CH15-HY Condition : AVG_BE_54 3m 91200_15_1620 HORIZONTAL Detector : Peak Project : 942629 Mode : ID</p>	<p>Left blank</p>

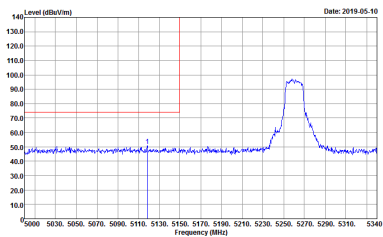
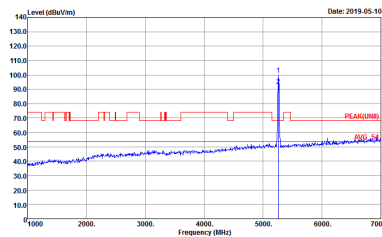
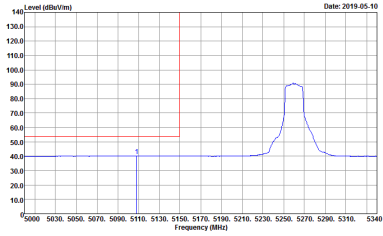

WIFI	Band 2 5250~5350MHz Band Edge @ 3m	
ANT	802.11a CH52 5260MHz - L	
1	Vertical	Fundamental
Peak	 <p>Site : 03CH15-HY Condition : PEAK_BE_74 3m 91200_15_1620 VERTICAL Detector : Peak Project : 942629 Mode : ID</p>	 <p>Site : 03CH15-HY Condition : PEAK(LINII) 3m 91200_15_1620 VERTICAL Detector : Peak Project : 942629 Mode : ID</p>
Avg.	 <p>Site : 03CH15-HY Condition : AVG_BE_54 3m 91200_15_1620 VERTICAL Detector : Peak Project : 942629 Mode : ID</p>	Left blank

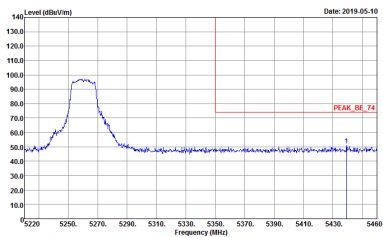
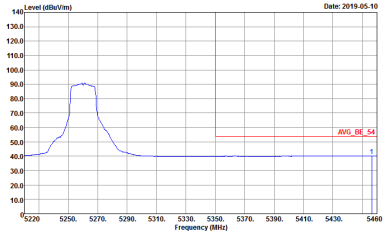

WIFI	Band 2 5250~5350MHz Band Edge @ 3m	
ANT	802.11a CH52 5260MHz - R	
1	Vertical	Fundamental
Peak	 <p>Site : 03CH15-HY Condition : PEAK_BE_74 3m 9120D_15_1620 VERTICAL Detector : Peak Project : 942629 Mode : ID</p>	Left blank
Avg.	 <p>Site : 03CH15-HY Condition : AVG_BE_54 3m 9120D_15_1620 VERTICAL Detector : Peak Project : 942629 Mode : ID</p>	Left blank

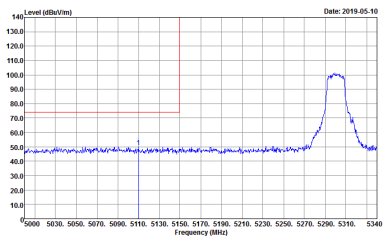
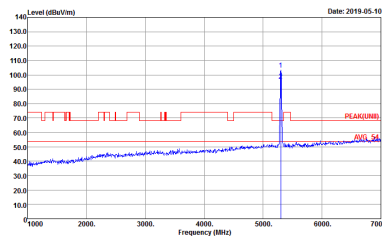
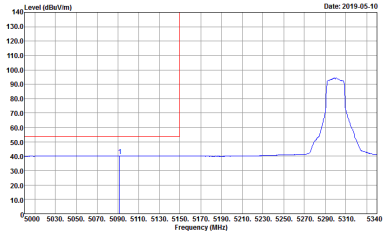

WIFI	Band 2 5250~5350MHz Band Edge @ 3m	
ANT	802.11a CH60 5300MHz - L	
1	Horizontal	Fundamental
Peak	 <p>Date: 2019-05-10</p> <p>Site : 03CH15-HY Condition : PEAK_BE_74 3m 91200_15_1620 HORIZONTAL RBW:1000.000KHz VBW:3000.000KHz SWT:Auto Detector : Peak Project : 942629 Mode : 11</p>	 <p>Date: 2019-05-10</p> <p>Site : 03CH15-HY Condition : PEAKUNII 3m 91200_15_1620 HORIZONTAL RBW:1000.000KHz VBW:3000.000KHz SWT:Auto Detector : Peak Project : 942629 Mode : 11</p>
Avg.	 <p>Date: 2019-05-10</p> <p>Site : 03CH15-HY Condition : AVG_BE_54 3m 91200_15_1620 HORIZONTAL RBW:1000.000KHz VBW:0.010KHz SWT:Auto Detector : Peak Project : 942629 Mode : 11</p>	Left blank

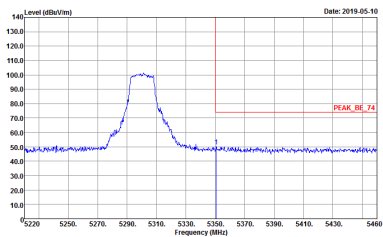
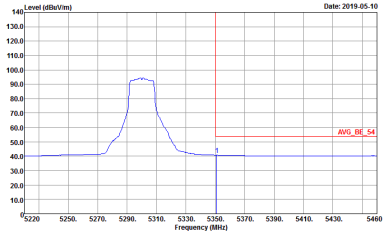

WIFI	Band 2 5250~5350MHz Band Edge @ 3m	
ANT	802.11a CH60 5300MHz - R	
1	Horizontal	Fundamental
Peak	 <p>Site : 03CH15-HY Condition : PEAK_BE_74 3m 91200_15_1620 HORIZONTAL Detector : Peak Project : 942629 Mode : I1</p>	Left blank
Avg.	 <p>Site : 03CH15-HY Condition : AVG_BE_54 3m 91200_15_1620 HORIZONTAL Detector : Peak Project : 942629 Mode : I1</p>	Left blank



WIFI	Band 2 5250~5350MHz Band Edge @ 3m	
ANT	802.11a CH60 5300MHz - L	
1	Vertical	Fundamental
Peak	<p>Site : 03CH15-HY Condition : PEAK_BE_74 3m 91200_15_1620 VERTICAL Detector : RBW:1000.000KHz VBW:3000.000KHz SWT:Auto Project : 942629 Mode : 11</p>	<p>Site : 03CH15-HY Condition : PEAK(LINII) 3m 91200_15_1620 VERTICAL Detector : Peak Project : 942629 Mode : 11</p>
Avg.	<p>Site : 03CH15-HY Condition : AVG_BE_54 3m 91200_15_1620 VERTICAL Detector : Peak Project : 942629 Mode : 11</p>	Left blank

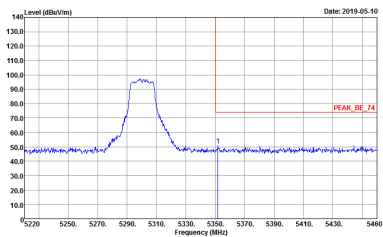
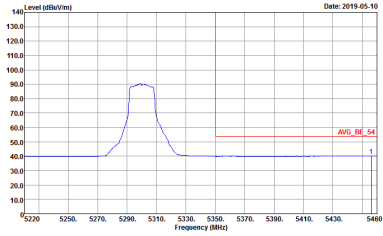

WIFI	Band 2 5250~5350MHz Band Edge @ 3m	
ANT	802.11a CH60 5300MHz - R	
1	Vertical	Fundamental
Peak	 <p>Site : 03CH15-HY Condition : PEAK_BE_74 3m 91200_15_1620 VERTICAL Detector : Peak Project : 942629 Mode : I1</p>	Left blank
Avg.	 <p>Site : 03CH15-HY Condition : AVG_BE_54 3m 91200_15_1620 VERTICAL Detector : Peak Project : 942629 Mode : I1</p>	Left blank

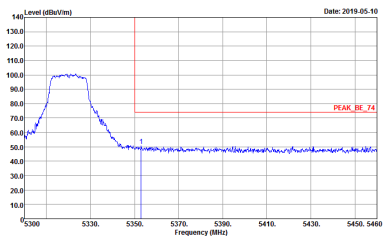
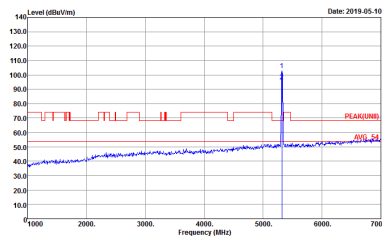
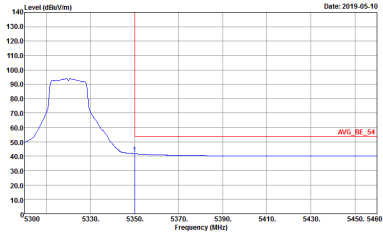

WIFI	Band 2 5250~5350MHz Band Edge @ 3m	
ANT	802.11a CH64 5320MHz	
1	Horizontal	Fundamental
<p>Peak</p>	 <p>Date: 2019-05-10</p> <p>Site : 03CH15-HY Condition : PEAK_BE_74 3m 91200_15_1620 HORIZONTAL RBW:1000.000KHz VBW:3000.000KHz SWT:Auto Detector : Peak Project : 942629 Mode : 12</p>	 <p>Date: 2019-05-10</p> <p>Site : 03CH15-HY Condition : PEAK(LINII) 3m 91200_15_1620 HORIZONTAL RBW:1000.000KHz VBW:3000.000KHz SWT:Auto Detector : Peak Project : 942629 Mode : 12</p>
<p>Avg.</p>	 <p>Date: 2019-05-10</p> <p>Site : 03CH15-HY Condition : AVG_BE_54 3m 91200_15_1620 HORIZONTAL RBW:1000.000KHz VBW:3000.000KHz SWT:Auto Detector : Peak Project : 942629 Mode : 12</p>	<p>Left blank</p>

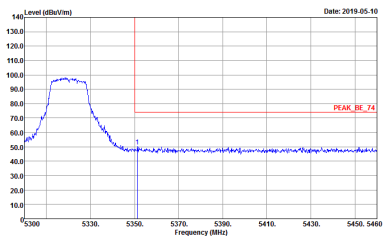
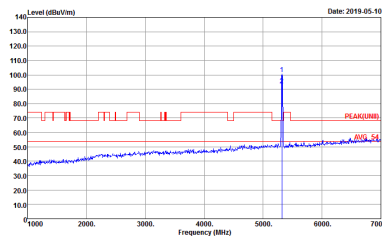
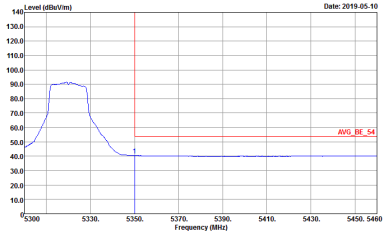

WIFI	Band 2 5250~5350MHz Band Edge @ 3m	
ANT	802.11a CH64 5320MHz	
1	Vertical	Fundamental
Peak	 <p>Date: 2019-05-10</p> <p>Site : 03CH15-HY Condition : PEAK_BE_74 3m 91200_15_1620 VERTICAL : RBW:1000.000KHz VBW:3000.000KHz SWT:Auto Detector : Peak Project : 942629 Mode : 12</p>	 <p>Date: 2019-05-10</p> <p>Site : 03CH15-HY Condition : PEAK(LINII) 3m 91200_15_1620 VERTICAL : RBW:1000.000KHz VBW:3000.000KHz SWT:Auto Detector : Peak Project : 942629 Mode : 12</p>
Avg.	 <p>Date: 2019-05-10</p> <p>Site : 03CH15-HY Condition : AVG_BE_54 3m 91200_15_1620 VERTICAL : RBW:1000.000KHz VBW:0.010KHz SWT:Auto Detector : Peak Project : 942629 Mode : 12</p>	Left blank

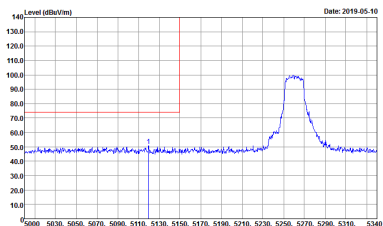
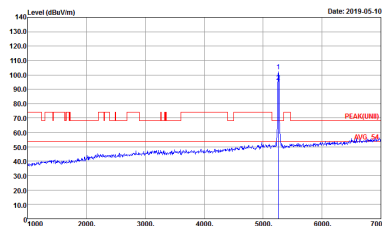
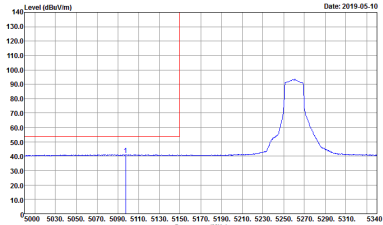

Band 2 5250~5350MHz
WIFI 802.11n HT20 (Band Edge @ 3m)

WIFI	Band 2 5250~5350MHz Band Edge @ 3m	
ANT	802.11n HT20 CH52 5260MHz - L	
1	Horizontal	Fundamental
<p align="center">Peak</p>	 <p>Site : 03CH15-HY Condition : PEAK_BE_74 3m 91200_15_1620 HORIZONTAL RBW:1000.000KHz VBW:3000.000KHz SWT:Auto Detector : Peak Project : 942629 Mode : 13</p>	 <p>Site : 03CH15-HY Condition : PEAK(UNIT) 3m 91200_15_1620 HORIZONTAL RBW:1000.000KHz VBW:3000.000KHz SWT:Auto Detector : Peak Project : 942629 Mode : 13</p>
<p align="center">Avg.</p>	 <p>Site : 03CH15-HY Condition : AVG_BE_54 3m 91200_15_1620 HORIZONTAL RBW:1000.000KHz VBW:1.000KHz SWT:Auto Detector : Peak Project : 942629 Mode : 13</p>	<p align="center">Left blank</p>



WIFI	Band 2 5250~5350MHz Band Edge @ 3m	
ANT	802.11n HT20 CH52 5260MHz - R	
1	Horizontal	Fundamental
<p>Peak</p>		<p>Left blank</p>
<p>Avg.</p>		<p>Left blank</p>

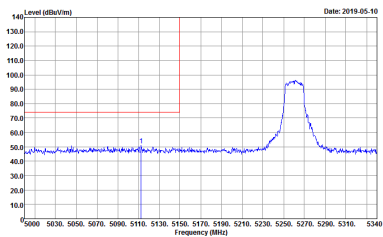
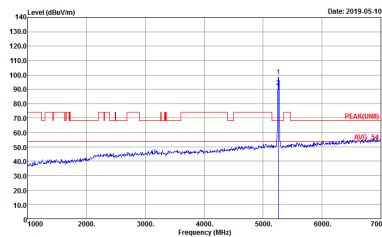
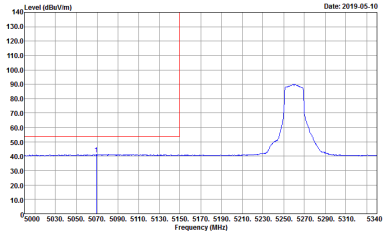

WIFI	Band 2 5250~5350MHz Band Edge @ 3m	
ANT	802.11n HT20 CH52 5260MHz - L	
1	Vertical	Fundamental
Peak	 <p>Site : 03CH15-HY Condition : PEAK_BE_74 3m 91200_15_1620 VERTICAL Detector : Peak Project : 942629 Mode : 13</p>	 <p>Site : 03CH15-HY Condition : PEAK(LINII) 3m 91200_15_1620 VERTICAL Detector : Peak Project : 942629 Mode : 13</p>
Avg.	 <p>Site : 03CH15-HY Condition : AVG_BE_54 3m 91200_15_1620 VERTICAL Detector : Peak Project : 942629 Mode : 13</p>	Left blank

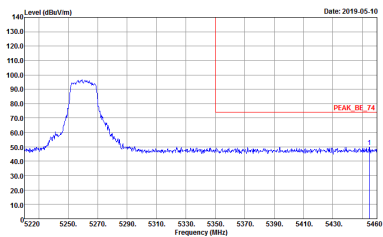
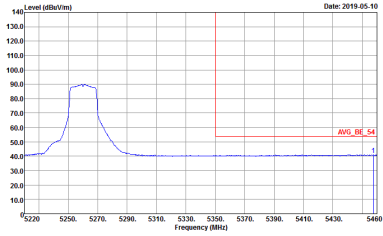

WIFI	Band 2 5250~5350MHz Band Edge @ 3m	
ANT	802.11n HT20 CH52 5260MHz - R	
1	Vertical	Fundamental
Peak	 <p>Site : 03CH15-HY Condition : PEAK_BE_74 3m 9120D_15_1620 VERTICAL Detector : Peak Project : 942629 Mode : 13</p>	Left blank
Avg.	 <p>Site : 03CH15-HY Condition : AVG_BE_54 3m 9120D_15_1620 VERTICAL Detector : Peak Project : 942629 Mode : 13</p>	Left blank



WIFI	Band 2 5250~5350MHz Band Edge @ 3m	
ANT	802.11n HT20 CH60 5300MHz - L	
1	Horizontal	Fundamental
Peak	<p>Date: 2019-05-10</p> <p>Site : 03CH15-HY Condition : PEAK_BE_74 3m 91200_15_1620 HORIZONTAL : RBW:1000.000KHz VBW:3000.000KHz SWT:Auto Detector : Peak Project : 942629 Mode : 14</p>	<p>Date: 2019-05-10</p> <p>Site : 03CH15-HY Condition : PEAK(LINII) 3m 91200_15_1620 HORIZONTAL : RBW:1000.000KHz VBW:3000.000KHz SWT:Auto Detector : Peak Project : 942629 Mode : 14</p>
Avg.	<p>Date: 2019-05-10</p> <p>Site : 03CH15-HY Condition : AVG_BE_54 3m 91200_15_1620 HORIZONTAL : RBW:1000.000KHz VBW:1000KHz SWT:Auto Detector : Peak Project : 942629 Mode : 14</p>	Left blank

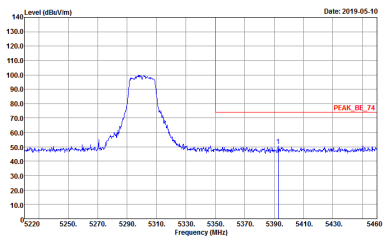
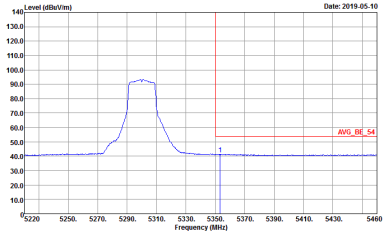

WIFI	Band 2 5250~5350MHz Band Edge @ 3m	
ANT	802.11n HT20 CH60 5300MHz - R	
1	Horizontal	Vertical
<p>Peak</p>	 <p>Site : 03CH15-HY Condition : PEAK_BE_74 3m 91200_15_1620 HORIZONTAL Detector : Peak Project : 942629 Mode : 14</p>	<p>Left blank</p>
<p>Avg.</p>	 <p>Site : 03CH15-HY Condition : AVG_BE_54 3m 91200_15_1620 HORIZONTAL Detector : Peak Project : 942629 Mode : 14</p>	<p>Left blank</p>

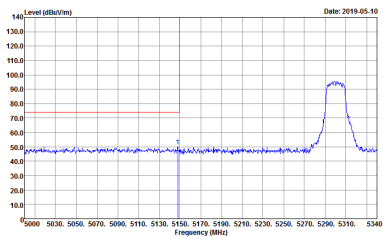
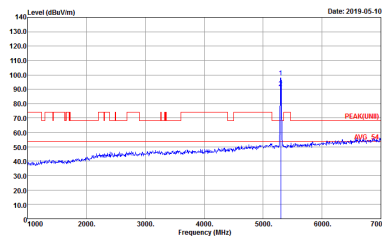
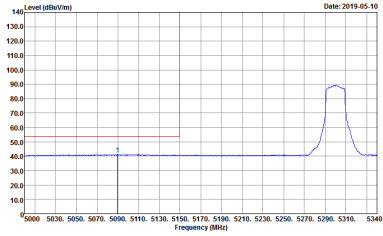

WIFI	Band 2 5250~5350MHz Band Edge @ 3m	
ANT	802.11n HT20 CH60 5300MHz - L	
1	Vertical	Fundamental
Peak	 <p>Date: 2019-05-10</p> <p>Site : 03CH15-HY Condition : PEAK_BE_74 3m 91200_15_1620 VERTICAL RBW:1000.000KHz VBW:3000.000KHz SWT:Auto Detector : Peak Project : 942629 Mode : 14</p>	 <p>Date: 2019-05-10</p> <p>Site : 03CH15-HY Condition : PEAK(UNII) 3m 91200_15_1620 VERTICAL RBW:1000.000KHz VBW:3000.000KHz SWT:Auto Detector : Peak Project : 942629 Mode : 14</p>
Avg.	 <p>Date: 2019-05-10</p> <p>Site : 03CH15-HY Condition : AVG_BE_54 3m 91200_15_1620 VERTICAL RBW:1000.000KHz VBW:1000KHz SWT:Auto Detector : Peak Project : 942629 Mode : 14</p>	Left blank

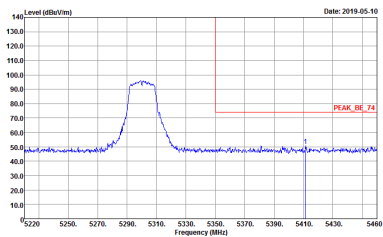
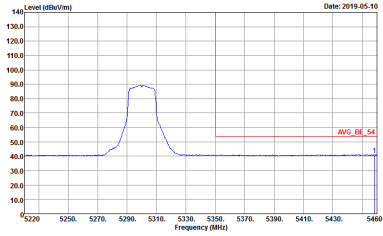

WIFI	Band 2 5250~5350MHz Band Edge @ 3m	
ANT	802.11n HT20 CH60 5300MHz - R	
1	Vertical	Fundamental
Peak	 <p>Site : 03CH15-HY Condition : PEAK_BE_74 3m 9120D_15_1620 VERTICAL Detector : Peak Project : 942629 Mode : 14</p>	Left blank
Avg.	 <p>Site : 03CH15-HY Condition : AVG_BE_54 3m 9120D_15_1620 VERTICAL Detector : Peak Project : 942629 Mode : 14</p>	Left blank



WIFI	Band 2 5250~5350MHz Band Edge @ 3m	
ANT	802.11n HT20 CH64 5320MHz	
1	Horizontal	Fundamental
<p>Peak</p>	<p>Site : 03CH15-HY Condition : PEAK_BE_74 3m 91200_15_1620 HORIZONTAL Detector : Peak Project : 942629 Mode : 15</p>	<p>Site : 03CH15-HY Condition : PEAK(LINII) 3m 91200_15_1620 HORIZONTAL Detector : Peak Project : 942629 Mode : 15</p>
<p>Avg.</p>	<p>Site : 03CH15-HY Condition : AVG_BE_54 3m 91200_15_1620 HORIZONTAL Detector : Peak Project : 942629 Mode : 15</p>	<p>Left blank</p>

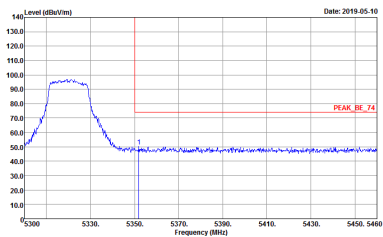
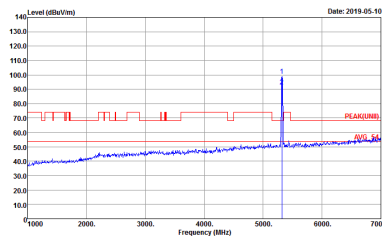
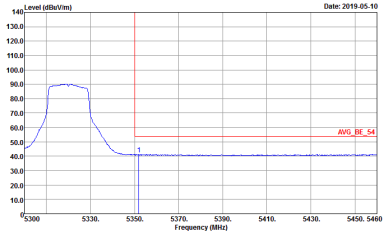

WIFI	Band 2 5250~5350MHz Band Edge @ 3m	
ANT	802.11n HT20 CH64 5320MHz	
1	Vertical	Fundamental
<p>Peak</p>	 <p>Site : 03CH15-HY Condition : PEAK_BE_74 3m 91200_15_1620 VERTICAL RBW:1000.000KHz VBW:3000.000KHz SWT:Auto Detector : Peak Project : 942629 Mode : 15</p>	 <p>Site : 03CH15-HY Condition : PEAK(LN11) 3m 91200_15_1620 VERTICAL RBW:1000.000KHz VBW:3000.000KHz SWT:Auto Detector : Peak Project : 942629 Mode : 15</p>
<p>Avg.</p>	 <p>Site : 03CH15-HY Condition : AVG_BE_54 3m 91200_15_1620 VERTICAL RBW:1000.000KHz VBW:1000KHz SWT:Auto Detector : Peak Project : 942629 Mode : 15</p>	<p>Left blank</p>



Band 2 5250~5350MHz
WIFI 802.11n HT40 (Band Edge @ 3m)

WIFI	Band 2 5250~5350MHz Band Edge @ 3m	
ANT	802.11n HT40 CH54 5270 MHz - L	
1	Horizontal	Fundamental
<p>Peak</p>	<p>Site : 03CH15-HY Condition : PEAK_BE_74 3m 91200_15_1620 HORIZONTAL RBW:1000.000KHz VBW:3000.000KHz SWT:Auto Detector : Peak Project : 942629 Mode : 16</p>	<p>Site : 03CH15-HY Condition : PEAK(UNIT) 3m 91200_15_1620 HORIZONTAL RBW:1000.000KHz VBW:3000.000KHz SWT:Auto Detector : Peak Project : 942629 Mode : 16</p>
<p>Avg.</p>	<p>Site : 03CH15-HY Condition : AVG_BE_54 3m 91200_15_1620 HORIZONTAL RBW:1000.000KHz VBW:3.000KHz SWT:Auto Detector : Peak Project : 942629 Mode : 16</p>	<p>Left blank</p>

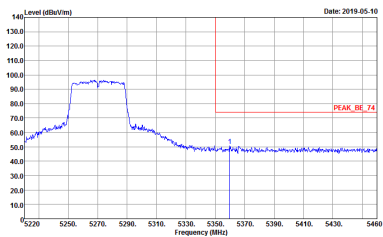
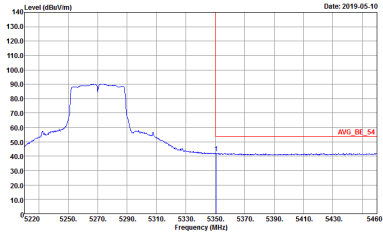

WIFI	Band 2 5250~5350MHz Band Edge @ 3m	
ANT	802.11n HT40 CH54 5270 MHz - R	
1	Horizontal	Fundamental
Peak	 <p>Site : 03CH15-HY Condition : PEAK_BE_74 3m 91200_15_1620 HORIZONTAL Detector : Peak Project : 942629 Mode : 16</p>	Left blank
Avg.	 <p>Site : 03CH15-HY Condition : AVG_BE_54 3m 91200_15_1620 HORIZONTAL Detector : Peak Project : 942629 Mode : 16</p>	Left blank



WIFI	Band 2 5250~5350MHz Band Edge @ 3m	
ANT	802.11n HT40 CH54 5270 MHz - L	
1	Vertical	Vertical
Peak		
Avg.		Left blank



WIFI	Band 2 5250~5350MHz Band Edge @ 3m	
ANT	802.11n HT40 CH54 5270 MHz - R	
1	Vertical	Vertical
<p>Peak</p>		<p>Left blank</p>
<p>Avg.</p>		<p>Left blank</p>



WIFI	Band 2 5250~5350MHz Band Edge @ 3m	
ANT	802.11n HT40 CH62 5310 MHz - L	
1	Horizontal	Fundamental
<p>Peak</p>	<p>Site : 03CH15-HY Condition : PEAK_BE_74 3m 91200_15_1620 HORIZONTAL Detector : Peak Project : 942629 Mode : 17</p>	<p>Site : 03CH15-HY Condition : PEAK(LINII) 3m 91200_15_1620 HORIZONTAL Detector : Peak Project : 942629 Mode : 17</p>
<p>Avg.</p>	<p>Site : 03CH15-HY Condition : AVG_BE_54 3m 91200_15_1620 HORIZONTAL Detector : Peak Project : 942629 Mode : 17</p>	<p>Left blank</p>

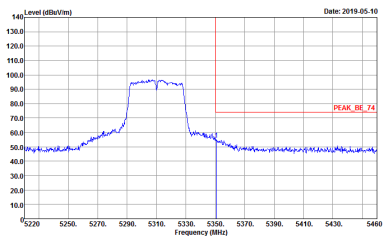
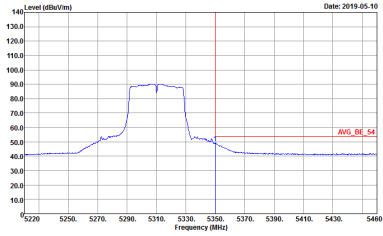

WIFI	Band 2 5250~5350MHz Band Edge @ 3m	
ANT	802.11n HT40 CH62 5310 MHz - R	
1	Horizontal	Fundamental
Peak	 <p>Site : 03CH15-HY Condition : PEAK_BE_74 3m 91200_15_1620 HORIZONTAL Detector : Peak Project : 942629 Mode : 17</p>	Left blank
Avg.	 <p>Site : 03CH15-HY Condition : AVG_BE_54 3m 91200_15_1620 HORIZONTAL Detector : Peak Project : 942629 Mode : 17</p>	Left blank

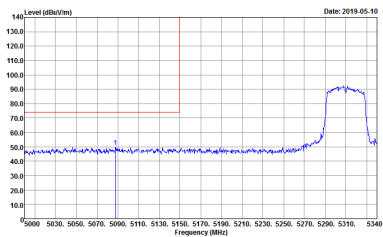
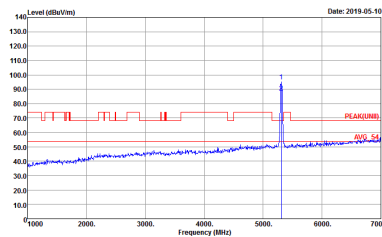
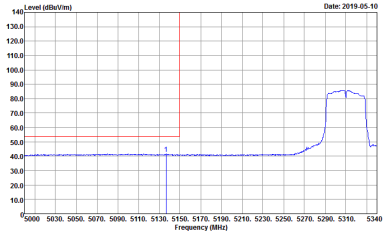

WIFI	Band 2 5250~5350MHz Band Edge @ 3m	
ANT	802.11n HT40 CH62 5310 MHz - L	
1	Vertical	Fundamental
Peak	 <p>Date: 2019-05-10</p> <p>Site : 03CH15-HY Condition : PEAK_BE_74 3m 91200_15_1620 VERTICAL : RBW:1000.000KHz VBW:3000.000KHz SWT:Auto Detector : Peak Project : 942629 Mode : 17</p>	 <p>Date: 2019-05-10</p> <p>Site : 03CH15-HY Condition : PEAK(UNII) 3m 91200_15_1620 VERTICAL : RBW:1000.000KHz VBW:3000.000KHz SWT:Auto Detector : Peak Project : 942629 Mode : 17</p>
Avg.	 <p>Date: 2019-05-10</p> <p>Site : 03CH15-HY Condition : AVG_BE_54 3m 91200_15_1620 VERTICAL : RBW:1000.000KHz VBW:3.000KHz SWT:Auto Detector : Peak Project : 942629 Mode : 17</p>	Left blank

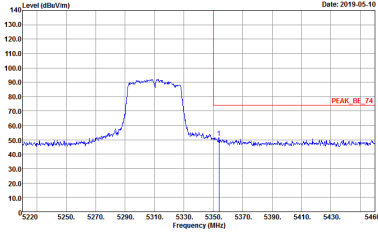
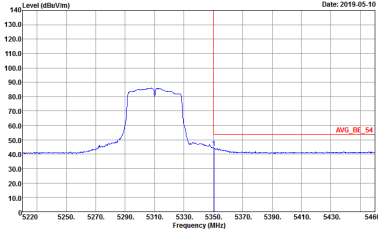

WIFI	Band 2 5250~5350MHz Band Edge @ 3m	
ANT	802.11n HT40 CH62 5310 MHz - R	
1	Vertical	Fundamental
Peak	 <p> Site : 03CH15-HY Condition : PEAK_BE_74 3m 91200_15_1620 VERTICAL Detector : Peak Project : 942629 Mode : 17 </p>	Left blank
Avg.	 <p> Site : 03CH15-HY Condition : AVG_BE_54 3m 91200_15_1620 VERTICAL Detector : Peak Project : 942629 Mode : 17 </p>	Left blank

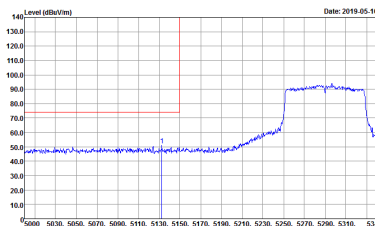
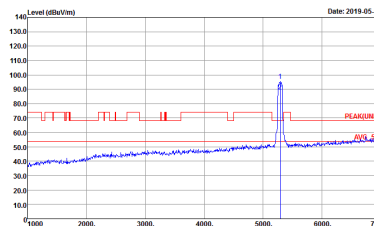
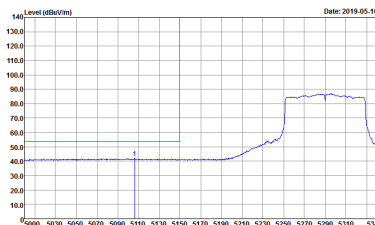

Band 2 5250~5350MHz
WIFI 802.11ac VHT80 (Band Edge @ 3m)

WIFI	Band 2 5250~5350MHz Band Edge @ 3m	
ANT	802.11ac VHT80 CH58 5290MHz - L	
1	Horizontal	Fundamental
<p align="center">Peak</p>	 <p>Site : 03CH15-HY Condition : PEAK_BE_74 3m 91200_15_1620 HORIZONTAL RBW:1000.000KHz VBW:3000.000KHz SWT:Auto Detector : Peak Project : 942629 Mode : 1B</p>	 <p>Site : 03CH15-HY Condition : PEAK(UNIT) 3m 91200_15_1620 HORIZONTAL RBW:1000.000KHz VBW:3000.000KHz SWT:Auto Detector : Peak Project : 942629 Mode : 1B</p>
<p align="center">Avg.</p>	 <p>Site : 03CH15-HY Condition : AVG_BE_54 3m 91200_15_1620 HORIZONTAL RBW:1000.000KHz VBW:3.000KHz SWT:Auto Detector : Peak Project : 942629 Mode : 1B</p>	<p align="center">Left blank</p>

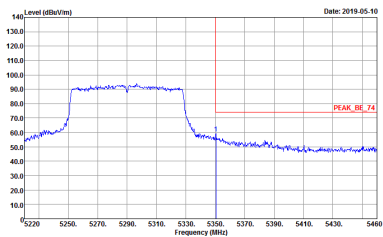
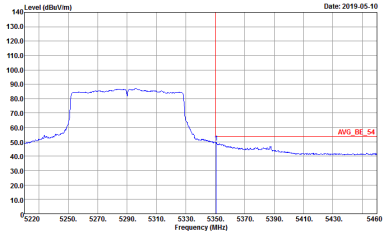

WIFI	Band 2 5250~5350MHz Band Edge @ 3m	
ANT	802.11ac VHT80 CH58 5290MHz - R	
1	Horizontal	Fundamental
<p>Peak</p>	 <p>Site : 03CH15-HY Condition : PEAK_BE_74 3m 91200_15_1620 HORIZONTAL Detector : Peak Project : 942629 Mode : 1B</p>	<p>Left blank</p>
<p>Avg.</p>	 <p>Site : 03CH15-HY Condition : AVG_BE_54 3m 91200_15_1620 HORIZONTAL Detector : Peak Project : 942629 Mode : 1B</p>	<p>Left blank</p>

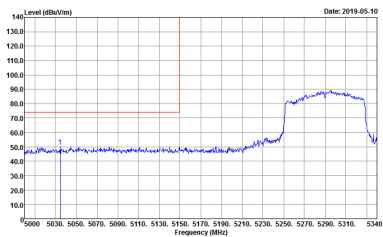
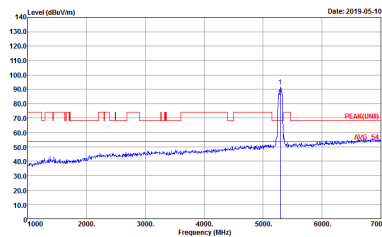
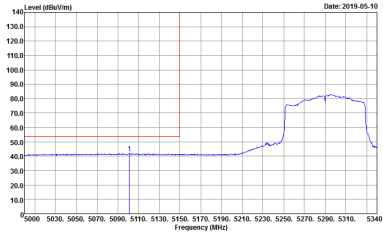

WIFI	Band 2 5250~5350MHz Band Edge @ 3m	
ANT	802.11ac VHT80 CH58 5290MHz - L	
1	Vertical	Fundamental
Peak	 <p>Site : 03CH15-HY Condition : PEAK_BE_74 3m 91200_15_1620 VERTICAL Detector : Peak Project : 942629 Mode : 1B</p>	 <p>Site : 03CH15-HY Condition : PEAK(LINII) 3m 91200_15_1620 VERTICAL Detector : Peak Project : 942629 Mode : 1B</p>
Avg.	 <p>Site : 03CH15-HY Condition : AVG_BE_54 3m 91200_15_1620 VERTICAL Detector : Peak Project : 942629 Mode : 1B</p>	Left blank

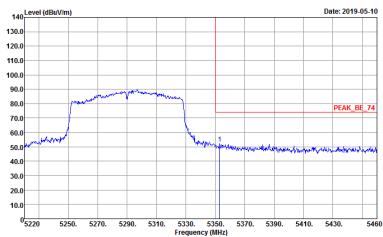
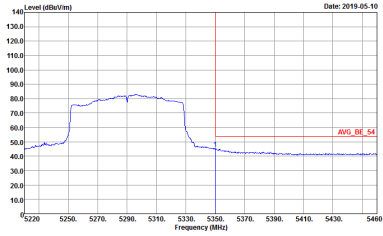

WIFI	Band 2 5250~5350MHz Band Edge @ 3m	
ANT	802.11ac VHT80 CH58 5290MHz - R	
1	Vertical	Fundamental
<p>Peak</p>	 <p>Site : 03CH15-HY Condition : PEAK_BE_74 3m 9120D_15_1620 VERTICAL Detector : Peak Project : 942629 Mode : 1B</p>	<p>Left blank</p>
<p>Avg.</p>	 <p>Site : 03CH15-HY Condition : AVG_BE_54 3m 9120D_15_1620 VERTICAL Detector : Peak Project : 942629 Mode : 1B</p>	<p>Left blank</p>



Band 2 - 5250~5350MHz

WIFI 802.11a (Harmonic @ 3m)

WIFI	Band 2 5250~5350MHz Harmonic @ 3m	
ANT	802.11a CH52 5260MHz	
1	Horizontal	Vertical
<p>Peak</p> <p>Avg.</p>	<p>Site : 03CH15-HY Condition : PEAR(LINE1) 3m 91200_15_1620 HORIZONTAL Detector : Peak Project : 942629 Mode : 10</p>	<p>Site : 03CH15-HY Condition : PEAR(LINE1) 3m 91200_15_1620 VERTICAL Detector : Peak Project : 942629 Mode : 10</p>

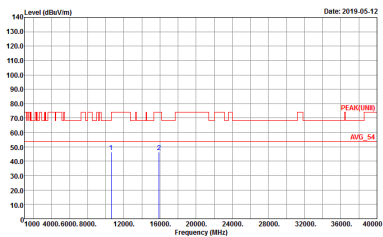
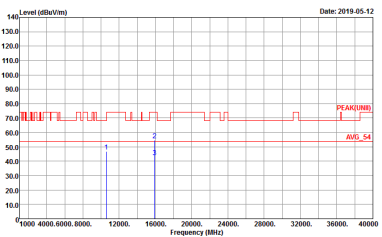

WIFI	Band 2 5250~5350MHz Harmonic @ 3m	
ANT	802.11a CH60 5300MHz	
1	Horizontal	Vertical
<p>Peak</p> <p>Avg.</p>	 <p>Site : 03CH15-111 Condition : PEAK(LINE) 3m 91200_15_1620 HORIZONTAL Detector : Peak Project : 942629 Mode : 11</p>	 <p>Site : 03CH15-111 Condition : PEAK(LINE) 3m 91200_15_1620 VERTICAL Detector : Peak Project : 942629 Mode : 11</p>

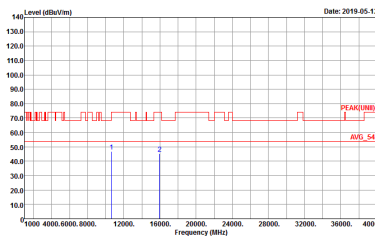
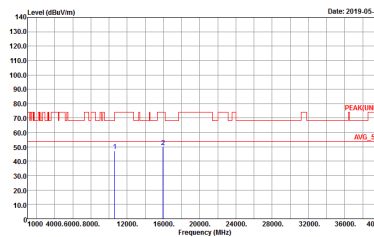

WIFI	Band 2 5250~5350MHz Harmonic @ 3m	
ANT	802.11a CH64 5320MHz	
1	Horizontal	Vertical
<p>Peak</p> <p>Avg.</p>	 <p>Site : 03CH15-11Y Condition : PEAK(LINE1) 3m 91200_15_1620 HORIZONTAL Detector : Peak Project : 942629 Mode : 12</p>	 <p>Site : 03CH15-11Y Condition : PEAK(LINE1) 3m 91200_15_1620 VERTICAL Detector : Peak Project : 942629 Mode : 12</p>



Band 2 5250~5350MHz
WIFI 802.11n HT20 (Harmonic @ 3m)

WIFI	Band 2 5250~5350MHz Harmonic @ 3m	
ANT	802.11n HT20 CH52 5260MHz	
1	Horizontal	Vertical
Peak Avg.		

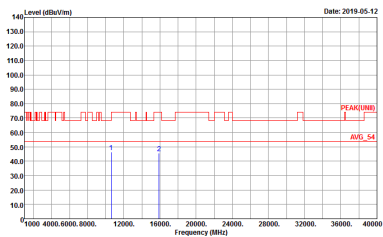
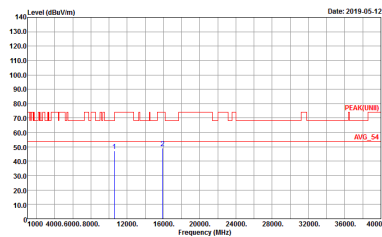

WIFI	Band 2 5250~5350MHz Harmonic @ 3m	
ANT	802.11n HT20 CH60 5300MHz	
1	Horizontal	Vertical
<p>Peak</p> <p>Avg.</p>	 <p>Site : 03CH15-11Y Condition : PEAK(LINE1) 3m 91200_15_1620 HORIZONTAL Detector : Peak Project : 942629 Mode : 14</p>	 <p>Site : 03CH15-11Y Condition : PEAK(LINE1) 3m 91200_15_1620 VERTICAL Detector : Peak Project : 942629 Mode : 14</p>



WIFI	Band 2 5250~5350MHz Harmonic @ 3m	
ANT	802.11n HT20 CH64 5320MHz	
1	Horizontal	Vertical
Peak Avg.	<p>Site : 03CH15-11Y Condition : PEAK(LINE) 3m 9120D_15_1620 HORIZONTAL Detector : Peak Project : 942629 Mode : 15</p>	<p>Site : 03CH15-11Y Condition : PEAK(LINE) 3m 9120D_15_1620 VERTICAL Detector : Peak Project : 942629 Mode : 15</p>



Band 2 5250~5350MHz
WIFI 802.11n HT40 (Harmonic @ 3m)

WIFI	Band 2 5250~5350MHz Harmonic @ 3m	
ANT	802.11n HT40 CH54 5270	
1	Horizontal	Vertical
Peak Avg.	<p>Site : 03CH15-HY Condition : PEAK(UNIT) 3m 91200_15_1620 HORIZONTAL Detector : Peak Project : 942629 Mode : 16</p>	<p>Site : 03CH15-HY Condition : PEAK(UNIT) 3m 91200_15_1620 VERTICAL Detector : Peak Project : 942629 Mode : 16</p>



WIFI	Band 2 5250~5350MHz Harmonic @ 3m	
ANT	802.11n HT40 CH62 5310	
1	Horizontal	Vertical
Peak Avg.	<p>Site : 03CH15-11Y Condition : PEAK(LINE1) 3m 91200_15_1620 HORIZONTAL Detector : Peak Project : 942629 Mode : 17</p>	<p>Site : 03CH15-11Y Condition : PEAK(LINE1) 3m 91200_15_1620 VERTICAL Detector : Peak Project : 942629 Mode : 17</p>



**Band 2 5250~5350MHz
WIFI 802.11ac VHT80 (Harmonic @ 3m)**

WIFI	Band 2 5250~5350MHz Harmonic @ 3m	
ANT	802.11ac VHT80 CH58 5290MHz	
1	Horizontal	Vertical
Peak Avg.	<p>Site : 03CH15-HY Condition : PEAK(LINII) 3m 91200_15_1620 HORIZONTAL Detector : Peak Project : 942629 Mode : 18</p>	<p>Site : 03CH15-HY Condition : PEAK(LINII) 3m 91200_15_1620 VERTICAL Detector : Peak Project : 942629 Mode : 18</p>

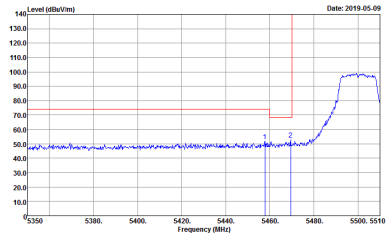
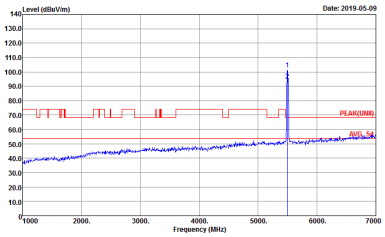
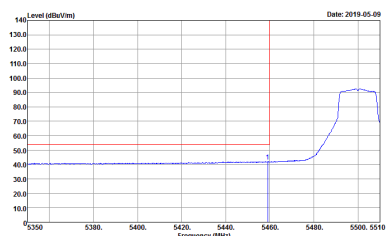

Band 3 - 5470~5725MHz
WIFI 802.11a (Band Edge @ 3m)

WIFI	Band 3 5470~5725MHz Band Edge @ 3m	
ANT	802.11a CH100 5500MHz	
1	Horizontal	Fundamental
Peak	 <p>Site : 03CH15-HY Condition : PEAK_BE(UNIT)_B3 3m 91200_15_1620 HORIZONTAL Detector : Peak Project : 942629 Mode : 19</p>	 <p>Site : 03CH15-HY Condition : PEAK(UNIT) 3m 91200_15_1620 HORIZONTAL Detector : Peak Project : 942629 Mode : 19</p>
Avg.	 <p>Site : 03CH15-HY Condition : AV6_BE(UNIT)_B3 3m 91200_15_1620 HORIZONTAL Detector : Peak Project : 942629 Mode : 19</p>	Left blank

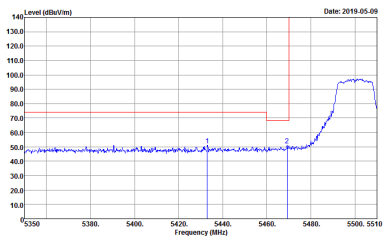
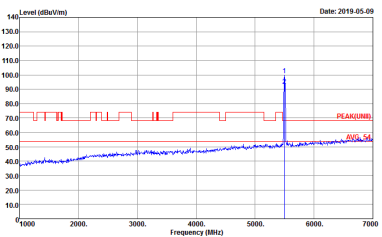
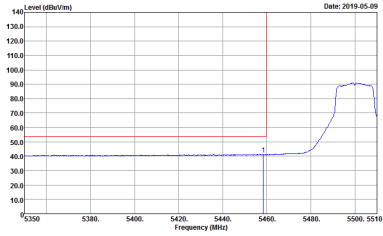

WIFI	Band 3 5470~5725MHz Band Edge @ 3m	
ANT	802.11a CH100 5500MHz	
1	Vertical	Fundamental
Peak	 <p>Date: 2019-05-09</p> <p>Site : 03CH15-HY Condition : PEAK_BE(UNIT1)_B3 3m 91200_15_1620 VERTICAL : RBW:1000.000KHz VBW:3000.000KHz SWT:Auto Detector : Peak Project : 942629 Mode : 19</p>	 <p>Date: 2019-05-09</p> <p>Site : 03CH15-HY Condition : PEAK(UNIT1)_3m 91200_15_1620 VERTICAL : RBW:1000.000KHz VBW:3000.000KHz SWT:Auto Detector : Peak Project : 942629 Mode : 19</p>
Avg.	 <p>Date: 2019-05-09</p> <p>Site : 03CH15-HY Condition : AVG_BE(UNIT1)_B3 3m 91200_15_1620 VERTICAL : RBW:1000.000KHz VBW:3000.000KHz SWT:Auto Detector : Peak Project : 942629 Mode : 19</p>	Left blank

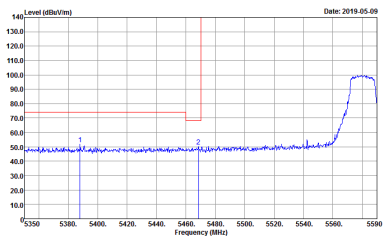
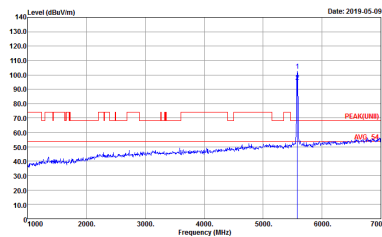
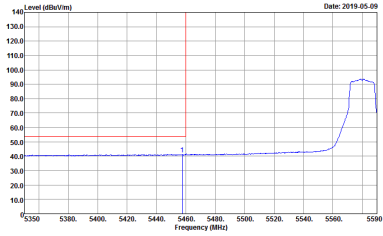

WIFI	Band 3 5470~5725MHz Band Edge @ 3m	
ANT	802.11a CH116 5580MHz - L	
1	Horizontal	Fundamental
Peak	 <p>Date: 2019-05-09</p> <p>Site : 03CH15-HY Condition : PEAK_BE(UNIT), B3 3m 91200_15_1620 HORIZONTAL : RBW:1000.000KHz VBW:3000.000KHz SWT:Auto Detector : Peak Project : 942629 Mode : Z0</p>	 <p>Date: 2019-05-09</p> <p>Site : 03CH15-HY Condition : PEAK(UNIT) 3m 91200_15_1620 HORIZONTAL : RBW:1000.000KHz VBW:3000.000KHz SWT:Auto Detector : Peak Project : 942629 Mode : Z0</p>
Avg.	 <p>Date: 2019-05-09</p> <p>Site : 03CH15-HY Condition : AVG_BE(UNIT), B3 3m 91200_15_1620 HORIZONTAL : RBW:1000.000KHz VBW:3000.000KHz SWT:Auto Detector : Peak Project : 942629 Mode : Z0</p>	Left blank



WIFI	Band 3 5470~5725MHz Band Edge @ 3m	
ANT	802.11a CH116 5580MHz - R	
1	Horizontal	Fundamental
Peak	<p>Site : D8CH15-4/F Condition : PEAK_BE([UNIT]), B3 3m 91200_15_1620 HORIZONTAL Detector : Peak Project : 942629 Mode : Z0</p>	Left blank

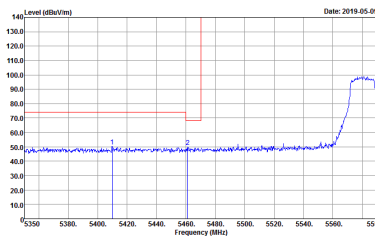
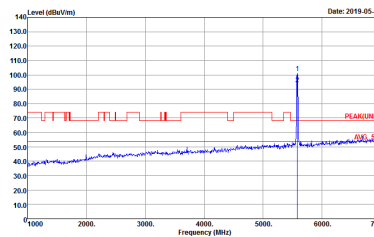
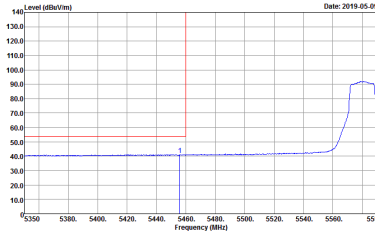

WIFI	Band 3 5470~5725MHz Band Edge @ 3m	
ANT	802.11a CH116 5580MHz - L	
1	Vertical	Fundamental
Peak	 <p>Date: 2019-05-09</p> <p>Site : 03CH15-HY Condition : PEAK_BE(UNIT), B3 3m 91200_15_1620 VERTICAL RBW:1000.000KHz VBW:3000.000KHz SWT:Auto Detector : Peak Project : 942629 Mode : Z0</p>	 <p>Date: 2019-05-09</p> <p>Site : 03CH15-HY Condition : PEAK(UNIT) 3m 91200_15_1620 VERTICAL RBW:1000.000KHz VBW:3000.000KHz SWT:Auto Detector : Peak Project : 942629 Mode : Z0</p>
Avg.	 <p>Date: 2019-05-09</p> <p>Site : 03CH15-HY Condition : AVG_BE(UNIT), B3 3m 91200_15_1620 VERTICAL RBW:1000.000KHz VBW:3000.000KHz SWT:Auto Detector : Peak Project : 942629 Mode : Z0</p>	Left blank



WIFI	Band 3 5470~5725MHz Band Edge @ 3m	
ANT	802.11a CH116 5580MHz - R	
1	Vertical	Fundamental
Peak	<p>Site : D8CH15-4/F Condition : PEAK_BE([UNIT]), B3 3m 91200_15_1620 VERTICAL Detector : Peak Project : 942629 Mode : 20</p>	Left blank

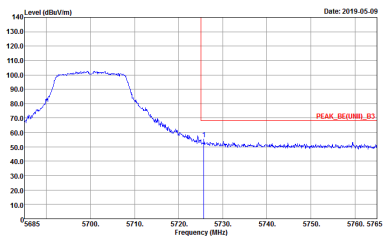
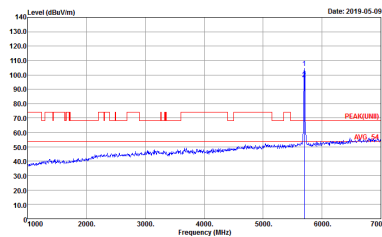

WIFI	Band 3 5470~5725MHz Band Edge @ 3m	
ANT	802.11a CH140 5700MHz	
1	Horizontal	Fundamental
<p>Peak</p>	 <p>Site : 03CH15-11Y Condition : PEAK_BE[UNII], B3 3m 91200_15_1620 HORIZONTAL Detector : RBW:1000.000KHz VBW:3000.000KHz SWT:Auto Project : 942629 Mode : 21</p>	 <p>Site : 03CH15-11Y Condition : PEAK[UNII] 3m 91200_15_1620 HORIZONTAL Detector : Peak Project : 942629 Mode : 21</p>

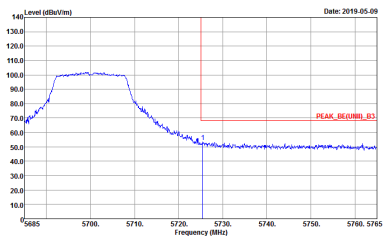
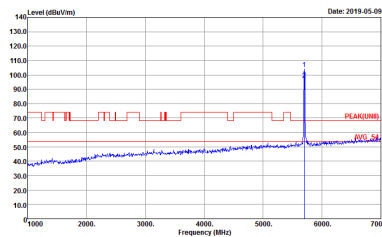

WIFI	Band 3 5470~5725MHz Band Edge @ 3m	
ANT	802.11a CH140 5700MHz	
1	Vertical	Fundamental
Peak	 <p>Date: 2019-05-09</p> <p>Site : 03CH15-11V Condition : PEAK_BE[UNII], B3 3m 91200_15_1620 VERTICAL Detector : RBW:1000.000KHz VBW:3000.000KHz SWT:Auto Project : 942629 Mode : 21</p>	 <p>Date: 2019-05-09</p> <p>Site : 03CH15-11V Condition : PEAK[UNII] 3m 91200_15_1620 VERTICAL Detector : Peak Project : 942629 Mode : 21</p>



Band 3 5470~5725MHz
WIFI 802.11n HT20 (Band Edge @ 3m)

Table with 2 columns (WIFI, ANT) and 2 rows (Peak, Avg.). It contains spectral analysis graphs for Horizontal and Fundamental signals, and a 'Left blank' graph. Each graph shows Level (dBm/10m) vs Frequency (MHz) with associated test parameters like Site, Condition, Detector, Project, and Mode.

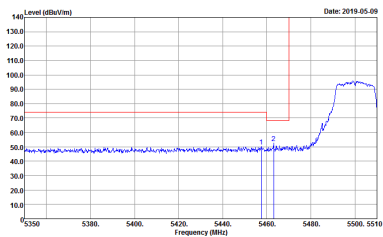
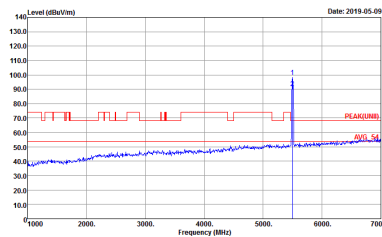
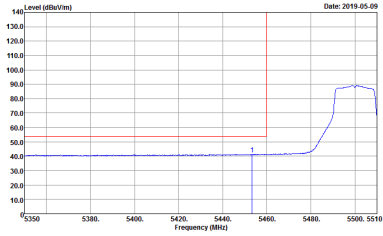

WIFI	Band 3 5470~5725MHz Band Edge @ 3m	
ANT	802.11n HT20 CH100 5500MHz	
1	Vertical	Fundamental
Peak	 <p>Site : 03CH15-HY Condition : PEAK_BE(UNIT1)_B3 3m 91200_15_1620 VERTICAL : RBW:1000.000KHz VBW:3000.000KHz SWT:Auto Detector : Peak Project : 942629 Mode : Z2</p>	 <p>Site : 03CH15-HY Condition : PEAK(UNIT1) 3m 91200_15_1620 VERTICAL : RBW:1000.000KHz VBW:3000.000KHz SWT:Auto Detector : Peak Project : 942629 Mode : Z2</p>
Avg.	 <p>Site : 03CH15-HY Condition : AVG_BE(UNIT1)_B3 3m 91200_15_1620 VERTICAL : RBW:1000.000KHz VBW:1000KHz SWT:Auto Detector : Peak Project : 942629 Mode : Z2</p>	Left blank

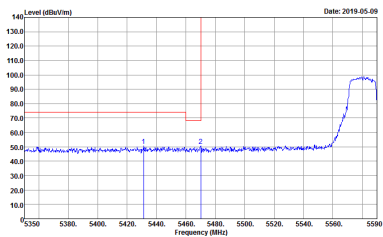
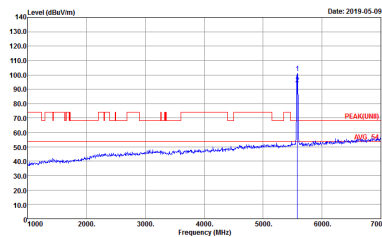
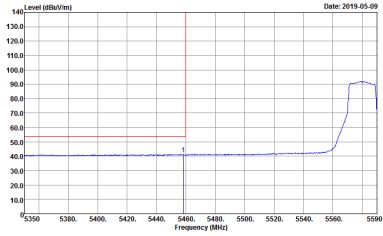

WIFI	Band 3 5470~5725MHz Band Edge @ 3m	
ANT	802.11n HT20 CH116 5580MHz - L	
1	Horizontal	Fundamental
Peak	 <p>Date: 2019-05-09</p> <p>Site : 03CH15-HY Condition : PEAK_BE(UNIT), B3 3m 91200_15_1620 HORIZONTAL : RBW:1000.000KHz VBW:3000.000KHz SWT:Auto Detector : Peak Project : 942629 Mode : Z3</p>	 <p>Date: 2019-05-09</p> <p>Site : 03CH15-HY Condition : PEAK(UNIT) 3m 91200_15_1620 HORIZONTAL : RBW:1000.000KHz VBW:3000.000KHz SWT:Auto Detector : Peak Project : 942629 Mode : Z3</p>
Avg.	 <p>Date: 2019-05-09</p> <p>Site : 03CH15-HY Condition : AVG_BE(UNIT), B3 3m 91200_15_1620 HORIZONTAL : RBW:1000.000KHz VBW:1000KHz SWT:Auto Detector : Peak Project : 942629 Mode : Z3</p>	Left blank



WIFI	Band 3 5470~5725MHz Band Edge @ 3m	
ANT	802.11n HT20 CH116 5580MHz - R	
1	Horizontal	Fundamental
Peak	<p>Site : D8CH15-4/F Condition : PEAK_BE([UNIT], B3 3m 91200_15_1620 HORIZONTAL) Detector : Peak Project : 942629 Mode : 23</p>	Left blank

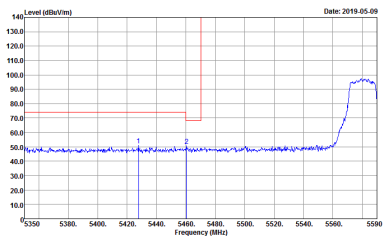
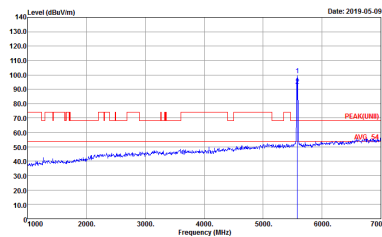
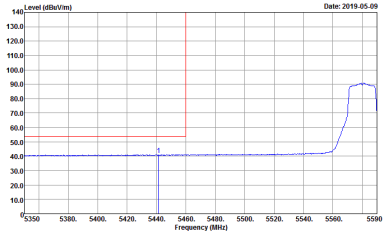

WIFI	Band 3 5470~5725MHz Band Edge @ 3m	
ANT	802.11n HT20 CH116 5580MHz - L	
1	Vertical	Fundamental
<p>Peak</p>	 <p>Site : 03CH15-HY Condition : PEAK_BE(UNIT), B3 3m 91200_15_1620 VERTICAL RBW:1000.000KHz VBW:3000.000KHz SWT:Auto Detector : Peak Project : 942629 Mode : Z3</p>	 <p>Site : 03CH15-HY Condition : PEAK(UNIT) 3m 91200_15_1620 VERTICAL RBW:1000.000KHz VBW:3000.000KHz SWT:Auto Detector : Peak Project : 942629 Mode : Z3</p>
<p>Avg.</p>	 <p>Site : 03CH15-HY Condition : AVG_BE(UNIT), B3 3m 91200_15_1620 VERTICAL RBW:1000.000KHz VBW:1000KHz SWT:Auto Detector : Peak Project : 942629 Mode : Z3</p>	<p>Left blank</p>



WIFI	Band 3 5470~5725MHz Band Edge @ 3m	
ANT	802.11n HT20 CH116 5580MHz - R	
1	Vertical	Fundamental
Peak	<p>Site : D8CH15-414 Condition : PEAK_BE([UNIT]), B3 3m 91200_15_1620 VERTICAL Detector : Peak Project : 942629 Mode : Z3</p>	Left blank

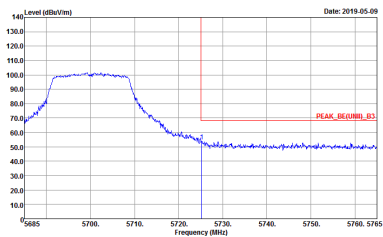
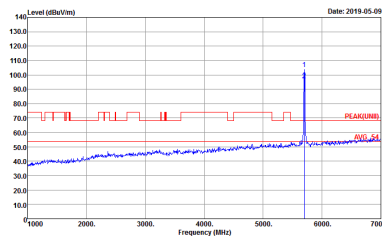

WIFI	Band 3 5470~5725MHz Band Edge @ 3m	
ANT	802.11n HT20 CH140 5700MHz	
1	Horizontal	Fundamental
Peak	 <p>Site : 03CH15-11V Condition : PEAK_BE[UNII], B3 3m 91200_15_1620 HORIZONTAL Detector : RBW:1000.000KHz VBW:3000.000KHz SWT:Auto Project : 942629 Mode : 24</p>	 <p>Site : 03CH15-11V Condition : PEAK[UNII] 3m 91200_15_1620 HORIZONTAL Detector : Peak Project : 942629 Mode : 24</p>

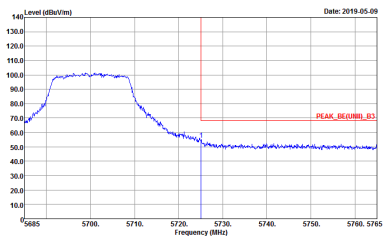
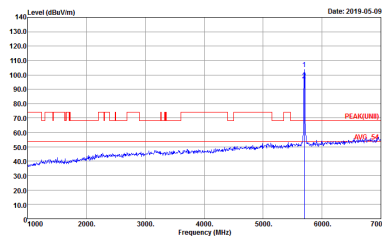

WIFI	Band 3 5470~5725MHz Band Edge @ 3m	
ANT	802.11n HT20 CH140 5700MHz	
1	Vertical	Fundamental
<p>Peak.</p>	 <p>Date: 2019-05-09</p> <p>Site : 03CH15-11V Condition : PEAK_BE[UNII], B3 3m 91200_15_1620 VERTICAL Detector : RBW:1000.000KHz VBW:3000.000KHz SWT:Auto Project : 942629 Mode : 24</p>	 <p>Date: 2019-05-09</p> <p>Site : 03CH15-11V Condition : PEAK[UNII] 3m 91200_15_1620 VERTICAL Detector : Peak Project : 942629 Mode : 24</p>



**Band 3 5470~5725MHz
WIFI 802.11n HT40 (Band Edge @ 3m)**

WIFI	Band 3 5470~5725MHz Band Edge @ 3m	
ANT	802.11n HT40 CH102 5510MHz - L	
1	Horizontal	Fundamental
Peak	<p>Site : 03CH15-1FY Condition : PEAK_BE(UNIT1)_B3 3m 91200_15_1620 HORIZONTAL RBW:1000.000KHz VBW:3000.000KHz SWT:Auto Detector : Peak Project : 942629 Mode : Z5</p>	<p>Site : 03CH15-1FY Condition : PEAK(UNIT1) 3m 91200_15_1620 HORIZONTAL RBW:1000.000KHz VBW:3000.000KHz SWT:Auto Detector : Peak Project : 942629 Mode : Z5</p>
Avg.	<p>Site : 03CH15-1FY Condition : AVG_BE(UNIT1)_B3 3m 91200_15_1620 HORIZONTAL RBW:1000.000KHz VBW:3.000KHz SWT:Auto Detector : Peak Project : 942629 Mode : Z5</p>	Left blank



WIFI	Band 3 5470~5725MHz Band Edge @ 3m	
ANT	802.11n HT40 CH102 5510MHz - R	
1	Horizontal	Fundamental
Peak	<p>Site : D3CH15-4/F Condition : PEAK_BE([UNIT], B3 3m 91200_15_1620 HORIZONTAL) Detector : Peak Project : 942629 Mode : Z5</p>	Left blank

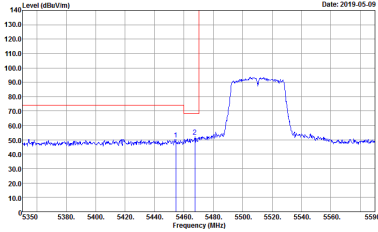
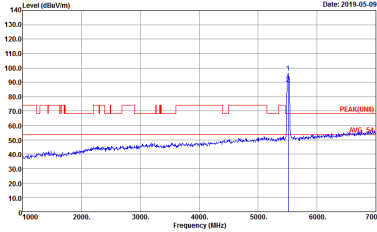
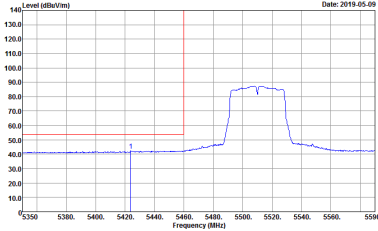

WIFI	Band 3 5470~5725MHz Band Edge @ 3m	
ANT	802.11n HT40 CH102 5510MHz - L	
1	Vertical	Fundamental
Peak	 <p>Date: 2019-05-09</p> <p>Site : 03CH15-HY Condition : PEAK_BE(UNIT), B3 3m 91200_15_1620 VERTICAL : RBW:1000.000KHz VBW:3000.000KHz SWT:Auto Detector : Peak Project : 942629 Mode : Z5</p>	 <p>Date: 2019-05-09</p> <p>Site : 03CH15-HY Condition : PEAK(UNIT) 3m 91200_15_1620 VERTICAL : RBW:1000.000KHz VBW:3000.000KHz SWT:Auto Detector : Peak Project : 942629 Mode : Z5</p>
Avg.	 <p>Date: 2019-05-09</p> <p>Site : 03CH15-HY Condition : AVG_BE(UNIT), B3 3m 91200_15_1620 VERTICAL : RBW:1000.000KHz VBW:3000.000KHz SWT:Auto Detector : Peak Project : 942629 Mode : Z5</p>	Left blank



WIFI	Band 3 5470~5725MHz Band Edge @ 3m	
ANT	802.11n HT40 CH102 5510MHz - R	
1	Vertical	Fundamental
Peak	<p>Site : D3CH15-414 Condition : PEAK_BE([UNIT]), B3 3m 91200_15_1620 VERTICAL Detector : Peak Project : 942629 Mode : Z5</p>	Left blank

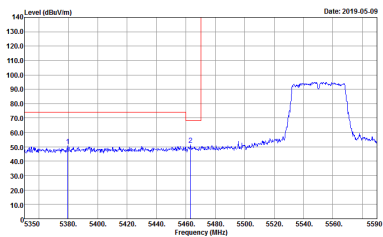
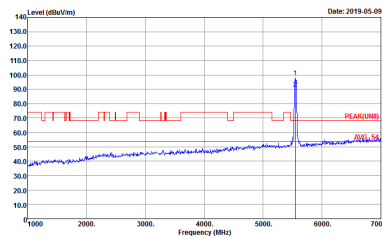
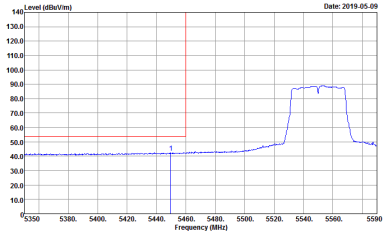

WIFI	Band 3 5470~5725MHz Band Edge @ 3m	
ANT	802.11n HT40 CH110 5550MHz - L	
1	Horizontal	Fundamental
Peak	 <p>Date: 2019-05-09</p> <p>Site : 03CH15-HY Condition : PEAK_BE(UNIT), B3 3m 91200_15_1620 HORIZONTAL : RBW:1000.000KHz VBW:3000.000KHz SWT:Auto Detector : Peak Project : 942629 Mode : Z6</p>	 <p>Date: 2019-05-09</p> <p>Site : 03CH15-HY Condition : PEAK(UNIT) 3m 91200_15_1620 HORIZONTAL : RBW:1000.000KHz VBW:3000.000KHz SWT:Auto Detector : Peak Project : 942629 Mode : Z6</p>
Avg.	 <p>Date: 2019-05-09</p> <p>Site : 03CH15-HY Condition : AVG_BE(UNIT), B3 3m 91200_15_1620 HORIZONTAL : RBW:1000.000KHz VBW:3.000KHz SWT:Auto Detector : Peak Project : 942629 Mode : Z6</p>	Left blank



WIFI	Band 3 5470~5725MHz Band Edge @ 3m	
ANT	802.11n HT40 CH110 5550MHz - R	
1	Horizontal	Fundamental
Peak	<p>Site : D3CH15-4/F Condition : PEAK_BE([UNIT]), B3 3m 91200_15_1620 HORIZONTAL Detector : Peak Project : 942629 Mode : Z6</p>	Left blank



WIFI	Band 3 5470~5725MHz Band Edge @ 3m	
ANT	802.11n HT40 CH110 5550MHz - L	
1	Vertical	Fundamental
Peak	<p>Site : 03CH15-HY Condition : PEAK_BE(UNIT1)_B3 3m 91200_15_1620 VERTICAL : RBW:1000.000KHz VBW:3000.000KHz SWT:Auto Detector : Peak Project : 942629 Mode : Z6</p>	<p>Site : 03CH15-HY Condition : PEAK(UNIT1)_3m 91200_15_1620 VERTICAL : RBW:1000.000KHz VBW:3000.000KHz SWT:Auto Detector : Peak Project : 942629 Mode : Z6</p>
Avg.	<p>Site : 03CH15-HY Condition : AVG_BE(UNIT1)_B3 3m 91200_15_1620 VERTICAL : RBW:1000.000KHz VBW:3.000KHz SWT:Auto Detector : Peak Project : 942629 Mode : Z6</p>	Left blank



WIFI	Band 3 5470~5725MHz Band Edge @ 3m	
ANT	802.11n HT40 CH110 5550MHz - R	
1	Vertical	Fundamental
Peak	<p>Site : D3CH15-414 Condition : PEAK_BE([UNIT]), B3 3m 91200_15_1620 VERTICAL Detector : Peak Project : 942629 Mode : Z6</p>	Left blank

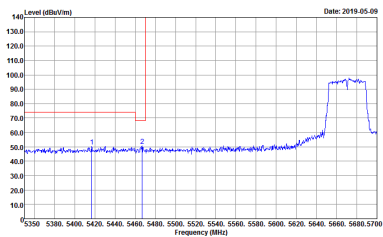
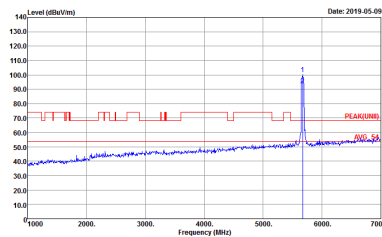
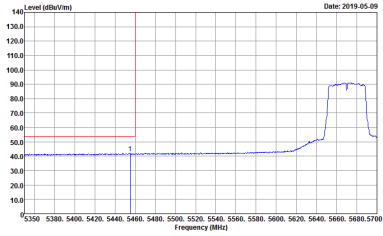

WIFI	Band 3 5470~5725MHz Band Edge @ 3m	
ANT	802.11n HT40 CH134 5670MHz - L	
1	Horizontal	Fundamental
Peak	 <p>Date: 2019-05-09</p> <p>Site : 03CH15-HY Condition : PEAK_BE(UNIT), B3 3m 91200_15_1620 HORIZONTAL : RBW:1000.000KHz VBW:3000.000KHz SWT:Auto Detector : Peak Project : 942629 Mode : 27</p>	 <p>Date: 2019-05-09</p> <p>Site : 03CH15-HY Condition : PEAK(UNIT) 3m 91200_15_1620 HORIZONTAL : RBW:1000.000KHz VBW:3000.000KHz SWT:Auto Detector : Peak Project : 942629 Mode : 27</p>
Avg.	 <p>Date: 2019-05-09</p> <p>Site : 03CH15-HY Condition : AVG_BE(UNIT), B3 3m 91200_15_1620 HORIZONTAL : RBW:1000.000KHz VBW:3.000KHz SWT:Auto Detector : Peak Project : 942629 Mode : 27</p>	Left blank



WIFI	Band 3 5470~5725MHz Band Edge @ 3m	
ANT	802.11n HT40 CH134 5670MHz - R	
1	Horizontal	Fundamental
Peak	<p>Site : D3CH15-4/F Condition : PEAK_BE([UNIT]), B3 3m 91200_15_1620 HORIZONTAL Detector : Peak RBW:1000.000KHz, VBW:3000.000KHz, SWT:Auto Project : 942629 Mode : 27</p>	Left blank

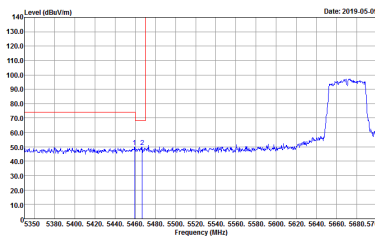
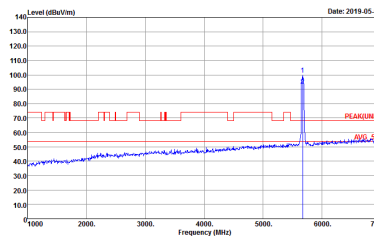
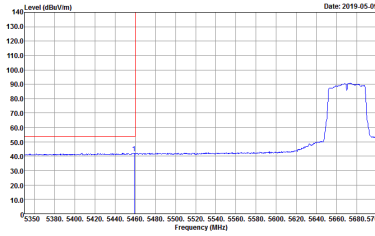

WIFI	Band 3 5470~5725MHz Band Edge @ 3m	
ANT	802.11n HT40 CH134 5670MHz - L	
1	Vertical	Fundamental
Peak	 <p>Site : 03CH15-HY Condition : PEAK_BE(UNIT)_B3 3m 91200_15_1620 VERTICAL RBW:1000.000KHz VBW:3000.000KHz SWT:Auto Detector : Peak Project : 942629 Mode : 27</p>	 <p>Site : 03CH15-HY Condition : PEAK(UNIT)_3m 91200_15_1620 VERTICAL RBW:1000.000KHz VBW:3000.000KHz SWT:Auto Detector : Peak Project : 942629 Mode : 27</p>
Avg.	 <p>Site : 03CH15-HY Condition : AVG_BE(UNIT)_B3 3m 91200_15_1620 VERTICAL RBW:1000.000KHz VBW:3000.000KHz SWT:Auto Detector : Peak Project : 942629 Mode : 27</p>	Left blank



WIFI	Band 3 5470~5725MHz Band Edge @ 3m	
ANT	802.11n HT40 CH134 5670MHz - R	
1	Vertical	Fundamental
Peak	<p>Site : D3CH15-411 Condition : PEAK_BE([UNIT]), B3 3m 91200_15_1620 VERTICAL Detector : Peak RBW:1000.000KHz, VBW:3000.000KHz, SWT:Auto Project : 942629 Mode : 27</p>	Left blank

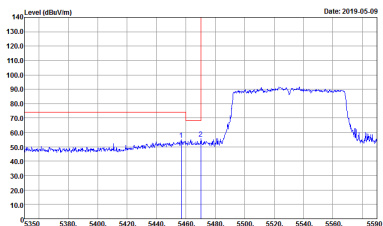
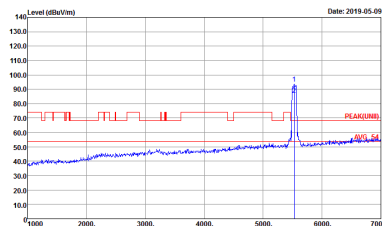
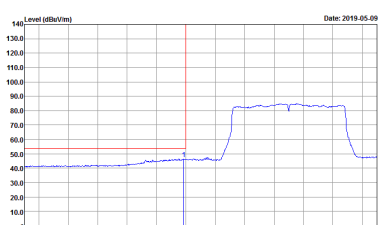

Band 3 5470~5725MHz
WIFI 802.11ac VHT80 (Band Edge @ 3m)

WIFI	Band 3 5470~5725MHz Band Edge @ 3m	
ANT	802.11ac VHT80 CH106 5530MHz - L	
1	Horizontal	Fundamental
Peak	 <p>Site : 03CH15-HY Condition : PEAK_BE(UNIT1)_B3 3m 91200_15_1620 HORIZONTAL RBW:1000.000KHz VBW:3000.000KHz SWT:Auto Detector : Peak Project : 942629 Mode : Z8</p>	 <p>Site : 03CH15-HY Condition : PEAK(UNIT1) 3m 91200_15_1620 HORIZONTAL RBW:1000.000KHz VBW:3000.000KHz SWT:Auto Detector : Peak Project : 942629 Mode : Z8</p>
Avg.	 <p>Site : 03CH15-HY Condition : AVG_BE(UNIT1)_B3 3m 91200_15_1620 HORIZONTAL RBW:1000.000KHz VBW:3.000KHz SWT:Auto Detector : Peak Project : 942629 Mode : Z8</p>	Left blank



WIFI	Band 3 5470~5725MHz Band Edge @ 3m	
ANT	802.11ac VHT80 CH106 5530MHz - R	
1	Horizontal	Fundamental
Peak	<p>Site : D8CH15-4/F Condition : PEAK_BE([UNIT]), B3 3m 91200_15_1620 HORIZONTAL Detector : Peak Project : 942629 Mode : ZB</p>	Left blank

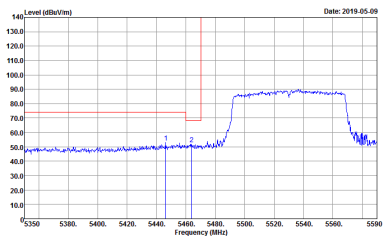
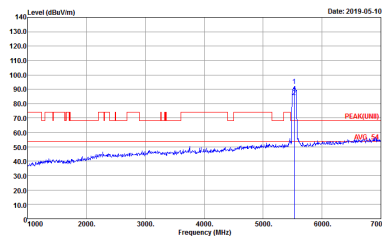
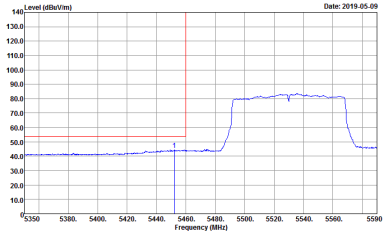

WIFI	Band 3 5470~5725MHz Band Edge @ 3m	
ANT	802.11ac VHT80 CH106 5530MHz - L	
1	Vertical	Fundamental
Peak	 <p>Date: 2019-05-09</p> <p>Site : 03CH15-HY Condition : PEAK_BE(UNIT), B3 3m 91200_15_1620 VERTICAL : RBW:1000.000KHz VBW:3000.000KHz SWT:Auto Detector : Peak Project : 942629 Mode : ZB</p>	 <p>Date: 2019-05-10</p> <p>Site : 03CH15-HY Condition : PEAK(UNIT) 3m 91200_15_1620 VERTICAL : RBW:1000.000KHz VBW:3000.000KHz SWT:Auto Detector : Peak Project : 942629 Mode : ZB</p>
Avg.	 <p>Date: 2019-05-09</p> <p>Site : 03CH15-HY Condition : AVG_BE(UNIT), B3 3m 91200_15_1620 VERTICAL : RBW:1000.000KHz VBW:3000.000KHz SWT:Auto Detector : Peak Project : 942629 Mode : ZB</p>	Left blank



WIFI	Band 3 5470~5725MHz Band Edge @ 3m	
ANT	802.11ac VHT80 CH106 5530MHz - R	
1	Vertical	Fundamental
Peak	<p>Site : D3CH15-414 Condition : PEAK_BE([UNIT]), B3 3m 91200_15_1620 VERTICAL Detector : Peak Project : 942629 Mode : ZB</p>	Left blank



Band 3 - 5470~5725MHz
WIFI 802.11a (Harmonic @ 3m)

WIFI	Band 3 5470~5725MHz Harmonic @ 3m	
ANT	802.11a CH100 5500MHz	
1	Horizontal	Vertical
Peak Avg.	<p>Site : 03CH15-HY Condition : PEAR(LINET) 3m 91200_15_1620 HORIZONTAL Detector : Peak Project : 942629 Mode : 19</p>	<p>Site : 03CH15-HY Condition : PEAR(LINET) 3m 91200_15_1620 VERTICAL Detector : Peak Project : 942629 Mode : 19</p>

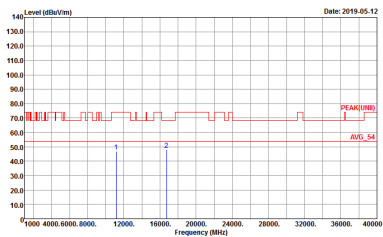
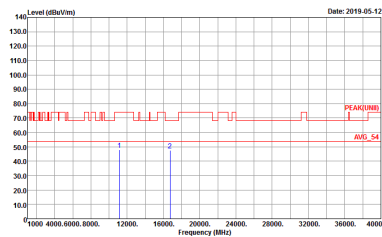

WIFI	Band 3 5470~5725MHz Harmonic @ 3m	
ANT	802.11a CH116 5580MHz	
1	Horizontal	Vertical
<p>Peak</p> <p>Avg.</p>	 <p>Site : 03CH15-11Y Condition : PEAK(LINE1) 3m 9120D_15_1620 HORIZONTAL Detector : Peak Project : 942629 Mode : 20</p>	 <p>Site : 03CH15-11Y Condition : PEAK(LINE1) 3m 9120D_15_1620 VERTICAL Detector : Peak Project : 942629 Mode : 20</p>



WIFI	Band 3 5470~5725MHz Harmonic @ 3m	
ANT	802.11a CH140 5700MHz	
1	Horizontal	Vertical
Peak Avg.	<p>Site : 03CH15-11Y Condition : PEAK(LINEI) 3m 9120D_15_1620 HORIZONTAL Detector : Peak Project : 942629 Mode : Z1</p>	<p>Site : 03CH15-11Y Condition : PEAK(LINEI) 3m 9120D_15_1620 VERTICAL Detector : Peak Project : 942629 Mode : Z1</p>



Band 3 5470~5725MHz
WIFI 802.11n HT20 (Harmonic @ 3m)

WIFI	Band 3 5470~5725MHz Harmonic @ 3m	
ANT	802.11n HT20 CH100 5500MHz	
1	Horizontal	Vertical
Peak Avg.		

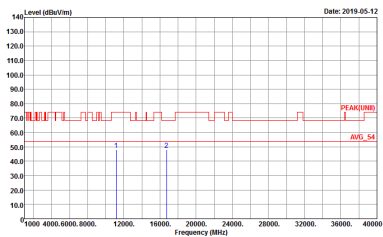
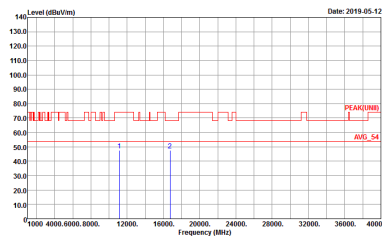

WIFI	Band 3 5470~5725MHz Harmonic @ 3m	
ANT	802.11n HT20 CH116 5580MHz	
1	Horizontal	Vertical
<p>Peak</p> <p>Avg.</p>	 <p>Site : 03CH15-11Y Condition : PEAK(LINE1) 3m 9120D_15_1620 HORIZONTAL Detector : Peak Project : 942629 Mode : 23</p>	 <p>Site : 03CH15-11Y Condition : PEAK(LINE1) 3m 9120D_15_1620 VERTICAL Detector : Peak Project : 942629 Mode : 23</p>



WIFI	Band 3 5470~5725MHz Harmonic @ 3m	
ANT	802.11n HT20 CH140 5700MHz	
1	Horizontal	Vertical
Peak Avg.	<p>Site : 03CH15-11Y Condition : PEAK(LINEI) 3m 9120D_15_1620 HORIZONTAL Detector : Peak Project : 942629 Mode : 24</p>	<p>Site : 03CH15-11Y Condition : PEAK(LINEI) 3m 9120D_15_1620 VERTICAL Detector : Peak Project : 942629 Mode : 24</p>



Band 3 5470~5725MHz
WIFI 802.11n HT40 (Harmonic @ 3m)

WIFI	Band 3 5470~5725MHz Harmonic @ 3m	
ANT	802.11n HT40 CH102 5510MHz	
1	Horizontal	Vertical
Peak Avg.	<p>Site : 03CH15-HY Condition : PEAK(LINII) 3m 91200_15_1620 HORIZONTAL Detector : Peak Project : 942629 Mode : 25</p>	<p>Site : 03CH15-HY Condition : PEAK(LINII) 3m 91200_15_1620 VERTICAL Detector : Peak Project : 942629 Mode : 25</p>

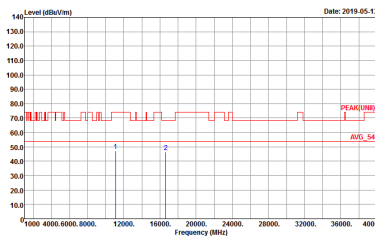
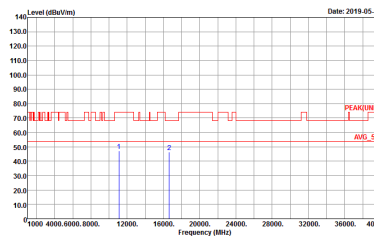

WIFI	Band 3 5470~5725MHz Harmonic @ 3m	
ANT	802.11n HT40 CH110 5550MHz	
1	Horizontal	Vertical
<p>Peak</p> <p>Avg.</p>	 <p>Site : 03CH15-11Y Condition : PEAK(LINE) 3m 91200_15_1620 HORIZONTAL Detector : Peak Project : 942629 Mode : 26</p>	 <p>Site : 03CH15-11Y Condition : PEAK(LINE) 3m 91200_15_1620 VERTICAL Detector : Peak Project : 942629 Mode : 26</p>

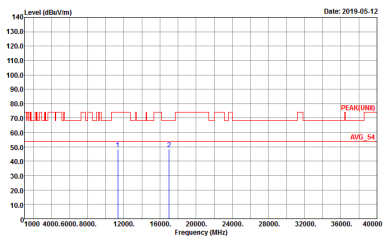
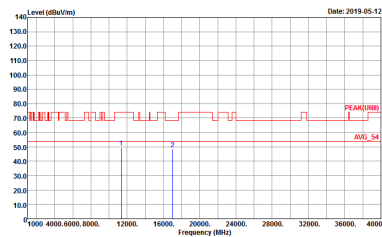

WIFI	Band 3 5470~5725MHz Harmonic @ 3m	
ANT	802.11n HT40 CH134 5670MHz	
1	Horizontal	Vertical
<p>Peak</p> <p>Avg.</p>	 <p>Site : 03CH15-11Y Condition : PEAK(LINEI) 3m 9120D_15_1620 HORIZONTAL Detector : Peak Project : 942629 Mode : 27</p>	 <p>Site : 03CH15-11Y Condition : PEAK(LINEI) 3m 9120D_15_1620 VERTICAL Detector : Peak Project : 942629 Mode : 27</p>



**Band 3 5470~5725MHz
WIFI 802.11ac VHT80 (Harmonic @ 3m)**

WIFI	Band 3 5470~5725MHz Harmonic @ 3m	
ANT	802.11ac VHT80 CH106 5530MHz	
1	Horizontal	Vertical
Peak Avg.	<p>Site : 03CH15-HY Condition : PEAK(LINII) 3m 91200_15_1620 HORIZONTAL Detector : Peak Project : 942629 Mode : 28</p>	<p>Site : 03CH15-HY Condition : PEAK(LINII) 3m 91200_15_1620 VERTICAL Detector : Peak Project : 942629 Mode : 28</p>



Emission below 1GHz
5GHz WIFI 802.11ac VHT80 (LF)

WIFI	5GHz WIFI	
ANT	802.11ac VHT80 LF	
1	Horizontal	Vertical
QP / Peak	<p>Site : 03CH15-HY Condition : QP 3m B1LOG_15_41912 HORIZONTAL Detector : Peak Project : 942629 Mode : Z9</p>	<p>Site : 03CH15-HY Condition : QP 3m B1LOG_15_41912 VERTICAL Detector : Peak Project : 942629 Mode : Z9</p>



Appendix E. Duty Cycle Plots

Band	Duty Cycle (%)	T(us)	1/T(kHz)	VBW Setting	Duty Factor (dB)
802.11a	98.11	-	-	10Hz	0.08
5GHz 802.11n HT20	97.47	1925.00	0.52	1kHz	0.11
5GHz 802.11n HT40	96.06	952.00	1.05	3kHz	0.17
5GHz 802.11ac VHT20	97.98	1945.00	0.51	1kHz	0.09
5GHz 802.11ac VHT40	96.56	954.00	1.05	3kHz	0.15
5GHz 802.11ac VHT80	92.02	461.00	2.17	3kHz	0.36

802.11a

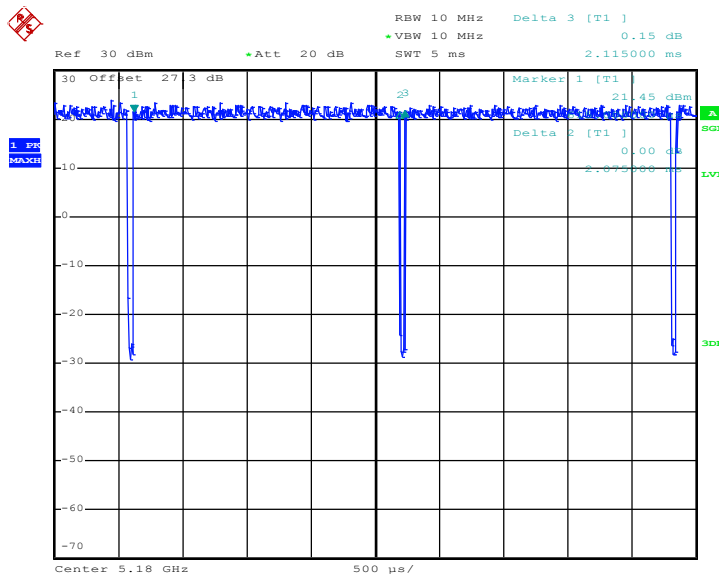

Date: 7.MAY.2019 15:24:07



802.11n HT20

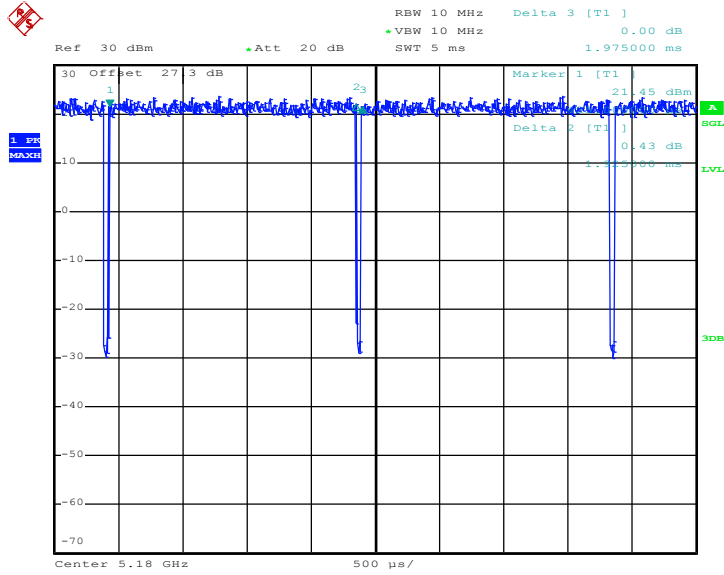

Date: 7.MAY.2019 15:25:54

802.11n HT40

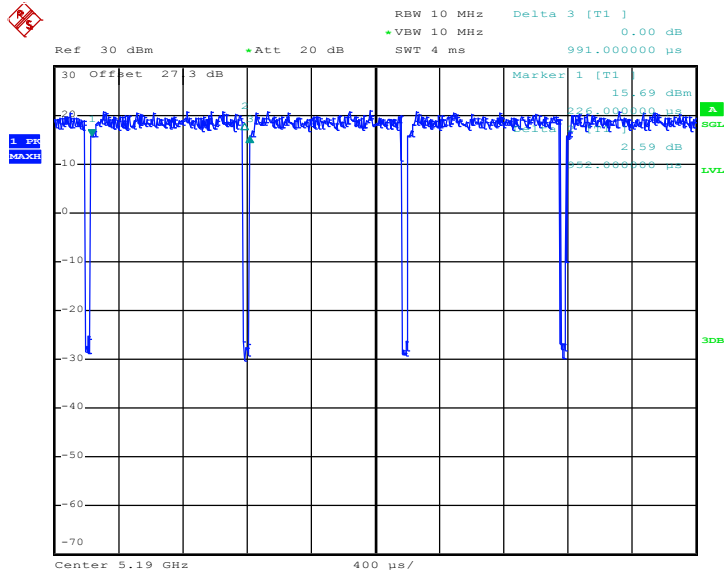

Date: 7.MAY.2019 15:26:57



802.11ac VHT20

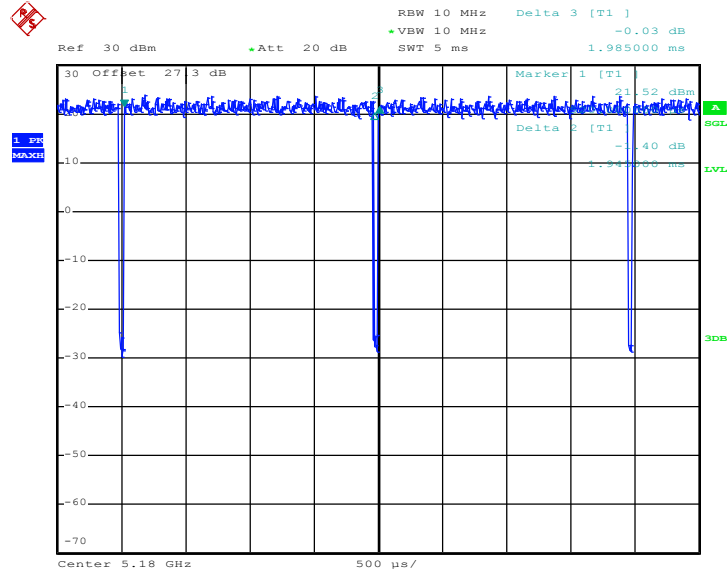

Date: 7.MAY.2019 15:28:28

802.11ac VHT40

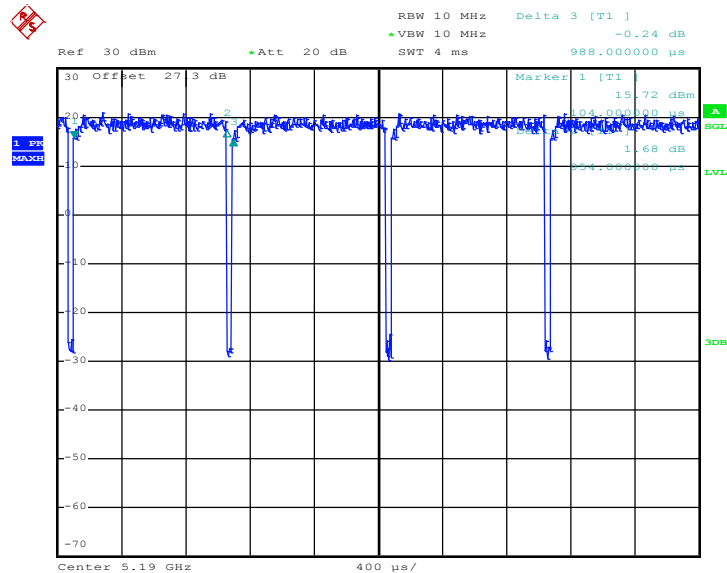

Date: 7.MAY.2019 15:29:40



802.11ac VHT80

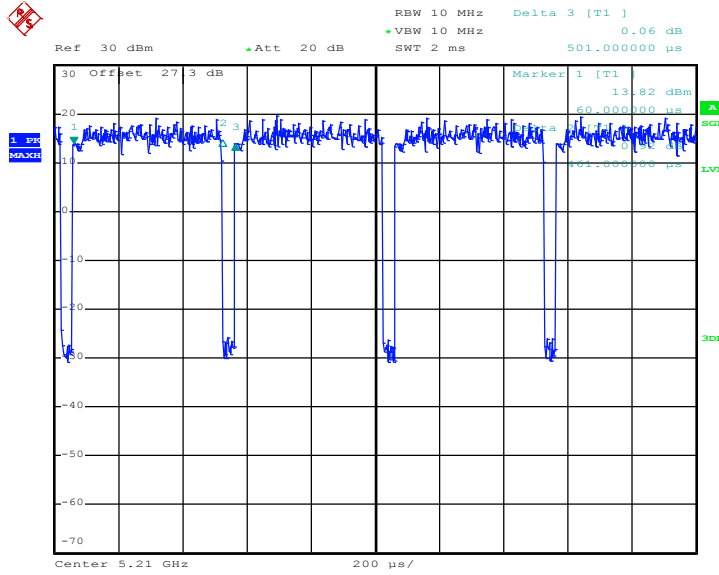

Date: 7.MAY.2019 15:31:11

————THE END————