



FCC RF Test Report

APPLICANT : Motorola Mobility LLC
EQUIPMENT : Mobile Cellular Phone
BRAND NAME : Motorola
MODEL NAME : XT2005-4, XT2005DL, XT2005-5
FCC ID : IHDT56YA2
STANDARD : 47 CFR Part 2, 22(H), 24(E), 27(L), 27(M), 27(F),
27(H), 27(N)
CLASSIFICATION : PCS Licensed Transmitter Held to Ear (PCE)

This is a data re-used report which is only valid together with the original test report. The product was received on Feb. 21, 2019 and completely tested on Mar. 26, 2019. We, Sporton International (Kunshan) Inc., would like to declare that the tested sample has been evaluated in accordance with the procedures given in ANSI C63.26-2015 and shown compliance with the applicable technical standards.

The test results in this report apply exclusively to the tested model / sample. Without written approval of Sporton International (Kunshan) Inc., the test report shall not be reproduced except in full.



Approved by: James Huang / Manager

Sporton International (Kunshan) Inc.
No. 1098, Pengxi North Road, Kunshan Economic Development Zone,
Jiangsu Province 215335, China



TABLE OF CONTENTS

REVISION HISTORY..... 3
SUMMARY OF TEST RESULT 4
1 GENERAL DESCRIPTION 6
1.1 Applicant 6
1.2 Manufacturer 6
1.3 Product Feature of Equipment Under Test..... 6
1.4 Product Specification of Equipment Under Test..... 7
1.5 Modification of EUT 7
1.6 Re-use of Measured Data 8
1.7 Maximum ERP/EIRP Power, Frequency Tolerance, and Emission Designator 10
1.8 Testing Location 12
1.9 Applicable Standards..... 12
2 TEST CONFIGURATION OF EQUIPMENT UNDER TEST 13
2.1 Test Mode 13
2.2 Connection Diagram of Test System..... 15
2.3 Support Unit used in test configuration and system 15
2.4 Measurement Results Explanation Example..... 15
2.5 Frequency List of Low/Middle/High Channels 16
3 CONDUCTED TEST ITEMS 18
3.1 Measuring Instruments 18
3.2 Test Setup 18
3.3 Test Result of Conducted Test 18
3.4 Conducted Output Power and ERP/EIRP 19
3.5 Peak-to-Average Ratio 20
3.6 Occupied Bandwidth 21
3.7 Conducted Band Edge 22
3.8 Conducted Spurious Emission 24
3.9 Frequency Stability 25
4 RADIATED TEST ITEMS 26
4.1 Measuring Instruments 26
4.2 Test Setup 26
4.3 Test Result of Radiated Test 26
4.4 Radiated Spurious Emission 27
5 LIST OF MEASURING EQUIPMENT 28
6 UNCERTAINTY OF EVALUATION 29
APPENDIX A. TEST RESULTS OF CONDUCTED TEST
APPENDIX B. TEST RESULTS OF RADIATED TEST
APPENDIX C. TEST SETUP PHOTOGRAPHS
APPENDIX D. REFERENCE REPORT



SUMMARY OF TEST RESULT

Report Section	FCC Rule	Description	Limit	Result	Remark
3.4	§2.1046	Conducted Output Power	Reporting Only	PASS	1
	§22.913(a)(5)	Effective Radiated Power (Band 5) (Band 26)	ERP < 7 Watt	PASS	1
	§27.50(b)(10) §27.50(c)(10)	Effective Radiated Power (Band 12) (Band 13) (Band 71)	ERP < 3 Watt	PASS	1
	§24.232(c) §27.50(h)(2)	Equivalent Isotropic Radiated Power (Band 2) (Band 25) (Band 41)	EIRP < 2Watt	PASS	1
	§27.50(d)(4)	Equivalent Isotropic Radiated Power (Band 4) (Band 66)	EIRP < 1Watt	PASS	1
3.5	§24.232(d)	Peak-to-Average Ratio	<13 dB	PASS	1
3.6	§2.1049	Occupied Bandwidth	Reporting Only	PASS	1
3.7	§2.1051 §22.917(a) §24.238(a) §27.53(c)(2)(4) §27.53(g) §27.53(h)	Conducted Band Edge Measurement (Band 2) (Band 4) (Band 5) (Band 12) (Band 13) (Band 25) (Band 26) (Band 66)(Band 71)	< 43+10log ₁₀ (P[Watts])	PASS	1
	§27.53(m)(4)	Conducted Band Edge Measurement (Band 41)	§27.53(m)(4)		
3.8	§2.1051 §22.917(a) §24.238(a) §27.53(c)(2) §27.53(g) §27.53(h)	Conducted Spurious Emission (Band 2) (Band 4) (Band 5) (Band 12) (Band 13) (Band 25) (Band 26) (Band 66) (Band 71)	< 43+10log ₁₀ (P[Watts])	PASS	1
	§2.1051 §27.53(m)(4)	Conducted Spurious Emission (Band 41)	< 55+10log ₁₀ (P[Watts])		
3.9	§2.1055 §22.355	Frequency Stability Temperature & Voltage	< 2.5 ppm for Part 22	PASS	1
	§2.1055 §24.235 §27.54		Within Authorized Band		



Report Section	FCC Rule	Description	Limit	Result	Remark
4.4	§2.1053 §22.917(a) §24.238(a) §27.53(c)(2) §27.53(f) §27.53(g) §27.53(h)	Radiated Spurious Emission (Band 2) (Band 4) (Band 5) (Band 12) (Band 13) (Band 25) (Band 26) (Band 66) (Band 71)	$< 43+10\log_{10}(P[\text{Watts}])$	PASS	Under limit 13.72 dB at 5148.00 MHz
	§2.1053 §27.53(m)(4)	Radiated Spurious Emission (Band 41)	$< 55+10\log_{10}(P[\text{Watts}])$		

Remark 1: Only LTE B13 and CA_B41 test item for full test, other LTE band re-uses another report detailed description please refer to section 1.6.



1 General Description

1.1 Applicant

Motorola Mobility LLC
222 W,Merchandise Mart Plaza, Chicago IL 60654 USA

1.2 Manufacturer

Motorola Mobility LLC
222 W,Merchandise Mart Plaza, Chicago IL 60654 USA

1.3 Product Feature of Equipment Under Test

Product Feature	
Equipment	Mobile Cellular Phone
Brand Name	Motorola
Model Name	XT2005-4, XT2005DL, XT2005-5
FCC ID	IHDT56YA2
EUT supports Radios application	CDMA/EV-DO/GSM/GPRS/EGPRS/WCDMA/HSPA/ DC-HSDPA/HSPA+(16QAM uplink is not supported)LTE WLAN 2.4GHz 802.11b/g/n HT20/HT40 WLAN 5GHz 802.11a/n HT20/HT40 Bluetooth BR / EDR / LE FM Receiver/GNSS
HW Version	88941-1-12
SW Version	fastboot_surfna_oem_userdebug_9_PPB29.12_2fc78_intcfg- test-keys_oem
EUT Stage	Identical Prototype



1.4 Product Specification of Equipment Under Test

Standards-related Product Specification	
Tx Frequency	LTE Band 2 : 1850.7 MHz ~ 1909.3 MHz LTE Band 4 : 1710.7 MHz ~ 1754.3 MHz LTE Band 5 : 824.7 MHz ~ 848.3 MHz LTE Band 12 : 699.7 MHz ~ 715.3 MHz LTE Band 13 : 779.5 MHz ~ 784.5 MHz LTE Band 25 : 1850.7MHz ~ 1914.3 MHz LTE Band 26 : 824.7MHz ~ 848.3 MHz LTE Band 41 : 2498.5 MHz ~ 2687.5 MHz LTE Band 66 : 1710.7 MHz ~ 1779.3 MHz LTE Band 71: 665.5 MHz ~ 695.5MHz
Rx Frequency	LTE Band 2 : 1930.7 MHz ~ 1989.3 MHz LTE Band 4 : 2110.7 MHz ~ 2154.3 MHz LTE Band 5 : 869.7 MHz ~ 893.3 MHz LTE Band 12 : 729.7 MHz ~ 745.3 MHz LTE Band 13 : 748.5 MHz ~ 753.5 MHz LTE Band 25 : 1930.7MHz ~ 1994.3 MHz LTE Band 26 : 869.7MHz ~ 893.3MHz LTE Band 41 : 2498.5 MHz ~ 2687.5 MHz LTE Band 66 : 2110.7 MHz~ 2179.3 MHz LTE Band 71: 619.5 MHz ~ 649.5MHz
Bandwidth	LTE Band 2 : 1.4MHz / 3MHz / 5MHz / 10MHz / 15MHz / 20MHz LTE Band 4 : 1.4MHz / 3MHz / 5MHz / 10MHz / 15MHz / 20MHz LTE Band 5 : 1.4MHz / 3MHz / 5MHz / 10MHz LTE Band 12 : 1.4MHz / 3MHz / 5MHz / 10MHz LTE Band 13 : 5MHz / 10MHz LTE Band 25 : 1.4MHz / 3MHz / 5MHz / 10MHz / 15MHz / 20MHz LTE Band 26 : 1.4MHz / 3MHz / 5MHz / 10MHz / 15MHz LTE Band 41 : 5MHz / 10MHz / 15MHz / 20MHz LTE Band 66 : 1.4MHz / 3MHz / 5MHz / 10MHz / 15MHz / 20MHz LTE Band 71 : 5MHz / 10MHz / 15MHz / 20MHz
Maximum Output Power to Antenna	LTE Band 13 : 22.92 dBm LTE Band CA_41C : 23.34 dBm
Antenna Gain	LTE Band 13 : -0.10 dBi LTE Band 41 : 1.50 dBi
Type of Modulation	QPSK / 16QAM / 64QAM

1.5 Modification of EUT

No modifications are made to the EUT during all test items.



1.6 Re-use of Measured Data

1.6.1 Introduction Section

This application re-uses data collected on a similar device. The subject device of this application (Model: XT2005-4, XT2005DL, XT2005-5, FCC ID: IHDT56YA2) is electrically identical to the reference device (Model: XT2005-3, FCC ID: IHDT56YA3) for the portions of the circuitry corresponding to the data being re-used, as treated by KDB Publication 484596 D01.

1.6.2 Difference Section

For details concerning the similarity with respect to component placement, mechanical/electrical design etc., please refer to the Product Equality Declaration.

The re-used RF data includes the following bands provided in Appendix A (Sporton RF Report No. FG922110B for the reference device Model: XT2005-3, FCC ID: IHDT56YA3).

1.6.3 Reference detail Section:

Equipment Class	Reference FCC ID	Folder Test	Report Title/Section
PCE (2G/3G)	IHDT56YA3	Part22H.24E.27L(FG922110A)	All sections applicable
PCE (LTE)	IHDT56YA3	Part22H.24E.27L.27M.27H.27N (FG922110B)	All sections applicable (LTE B13 and B41_CA for full test)



1.6.4 Spot Check Verification Data Section

In order to confirm hardware similarity of the subject device with the reference device, spot check measurements were performed on the subject device for the following test items, the test result were consistent with FCC ID: IHDT56YA3.

Assertions concerning the similarity of these devices are based on representations by the applicant. The applicant accepts full responsibility for the validity of the similarity claim, and for the determination that verification test data are sufficient to support it.

Test Item	Mode	IHDT56YA3 Worst Result	IHDT56YA2 Worst Result	Difference (dB)
Average Conducted Power (dBm)	GSM 850	32.19	32.74	-0.55
	GSM 1900	29.45	29.72	-0.27
	WCDMA Band II	22.39	23.38	-0.99
	WCDMA Band IV	22.42	22.79	-0.37
	WCDMA Band V	22.80	23.14	-0.34
	CDMA BC0	24.57	24.24	0.33
	CDMA BC1	24.74	24.31	0.43
	LTE Band 2	23.17	23.05	0.12
	LTE Band 4	23.15	22.95	0.20
	LTE Band 5	23.18	22.97	0.21
	LTE Band 12	23.19	22.97	0.22
	LTE Band 25	22.94	22.81	0.13
	LTE Band 26	23.27	23.10	0.17
	LTE Band 41	26.21	25.99	0.22
	LTE Band 66	22.85	23.86	-1.01
LTE Band 71	23.13	22.79	0.34	
Radiated Spurious Emission	GSM 850	-49.58	-52.61	3.03
	LTE Band 12	-66.09	-65.39	-0.70
	LTE Band 25	-52.11	-50.32	-1.79
	LTE Band 66	-53.72	-52.43	-1.29
	LTE Band 41	-39.44	-41.18	1.74
	LTE Band 71	-64.21	-64.24	0.03



1.7 Maximum ERP/EIRP Power, Frequency Tolerance, and Emission Designator

LTE Band 13		QPSK			16QAM		
BW (MHz)	Frequency Range (MHz)	Emission Designator (99%OBW)	Frequency Tolerance (ppm)	Maximum EIRP(W)	Emission Designator (99%OBW)	Frequency Tolerance (ppm)	Maximum EIRP(W)
5	779.5 ~ 784.5	4M51G7D		0.1135	4M51W7D		0.0962
10	782.0	9M01G7D	0.0065	0.1167	8M97W7D		0.0986
LTE Band 13		64QAM					
BW (MHz)	Frequency Range (MHz)	Emission Designator (99%OBW)		Frequency Tolerance (ppm)	Maximum EIRP(W)		
5	779.5 ~ 784.5	4M49W7D		-	0.0752		
10	782.0	8M95W7D		-	0.0766		



LTE Band 41 CA	QPSK			16QAM		
BW (MHz)	Emission Designator (99%OBW)	Frequency Tolerance (ppm)	Maximum EIRP(W)	Emission Designator (99%OBW)	Frequency Tolerance (ppm)	Maximum EIRP(W)
5MHz+20MHz	23M2G7D	-	0.3048	23M0W7D	-	0.2455
10MHz+15MHz	23M5G7D	-	0.3020	23M4W7D	-	0.2500
10MHz+20MHz	28M1G7D	-	0.2851	27M9W7D	-	0.2265
15MHz+10MHz	23M4G7D	-	0.2917	23M4W7D	-	0.2985
15MHz+15MHz	28M7G7D	-	0.2754	28M7W7D	-	0.2153
15MHz+20MHz	32M9G7D	-	0.2600	32M5W7D	-	0.2168
20MHz+5MHz	23M4G7D	-	0.2799	23M5W7D	-	0.2213
20MHz+10MHz	28M4G7D	-	0.2812	28M9W7D	-	0.2158
20MHz+15MHz	32M7G7D	-	0.2564	32M7W7D	-	0.2138
20MHz+20MHz	37M6G7D	0.02	0.2679	37M4W7D	-	0.2275
LTE Band 41 CA	64QAM					
BW (MHz)	Emission Designator (99%OBW)		Frequency Tolerance (ppm)		Maximum EIRP(W)	
5MHz+20MHz	23M2W7D		-		0.1754	
10MHz+15MHz	23M3W7D		-		0.2443	
10MHz+20MHz	28M0W7D		-		0.1517	
15MHz+10MHz	23M4W7D		-		0.2009	
15MHz+15MHz	28M5W7D		-		0.1538	
15MHz+20MHz	32M7W7D		-		0.1479	
20MHz+5MHz	23M3W7D		-		0.1426	
20MHz+10MHz	28M0W7D		-		0.1500	
20MHz+15MHz	32M6W7D		-		0.1932	
20MHz+20MHz	37M7W7D		-		0.1552	



1.8 Testing Location

Sporton Lab is accredited to ISO 17025 by National Voluntary Laboratory Accreditation Program (NVLAP code: 600155-0).

Test Site	Sporton International (Kunshan) Inc.		
Test Site Location	No. 1098, Pengxi North Road, Kunshan Economic Development Zone, Jiangsu Province 215335, China TEL : 86-512-57900158 FAX : 86-512-57900958		
Test Site No.	Sporton Site No.	FCC designation No.	FCC Test Firm Registration No.
	TH01-KS 03CH06-KS	CN5013	630927

1.9 Applicable Standards

According to the specifications of the manufacturer, the EUT must comply with the requirements of the following standards:

- ♦ 47 CFR Part 2, 22(H), 24(E), 27(L), 27(M), 27(H), 27(F),27(N)
- ♦ ANSI C63.26-2015
- ♦ FCC KDB 971168 D01 Power Meas License Digital Systems v03r01
- ♦ FCC KDB 412172 D01 Determining ERP and EIRP v01r01

Remark:

1. All test items were verified and recorded according to the standards and without any deviation during the test.
2. This EUT has also been tested and complied with the requirements of FCC Part 15, Subpart B, recorded in a separate test report.



2 Test Configuration of Equipment Under Test

2.1 Test Mode

Antenna port conducted and radiated test items listed below are performed according to KDB 971168 D01 Power Meas License Digital Systems v03r01 with maximum output power.

Radiated measurements are performed by rotating the EUT in three different orthogonal test planes to find the maximum emission.

Test Items	Band	Bandwidth (MHz)						Modulation			RB #			Test Channel		
		1.4	3	5	10	15	20	QPSK	16QAM	64QAM	1	Half	Full	L	M	H
Max. Output Power	13	-	-	v	v	-	-	v	v	v	v	v	v	v	v	v
Peak-to-Average Ratio	13	-	-		v	-	-	v	v	v	v		v	v	v	v
26dB and 99% Bandwidth	13	-	-	v	v	-	-	v	v				v	v	v	v
Conducted Band Edge	13	-	-	v	v	-	-	v	v		v		v	v		v
Conducted Spurious Emission	13	-	-	v	v	-	-	v	v		v			v	v	v
Frequency Stability	13	-	-		v	-	-	v					v		v	
E.R.P / E.I.R.P	13	-	-	v	v	-	-	v	v		v			v	v	v
Radiated Spurious Emission	13	Worst Case												v		
Note	<ol style="list-style-type: none"> The mark "v " means that this configuration is chosen for testing The mark "- " means that this bandwidth is not supported. The device is investigated from 30MHz to 10 times of fundamental signal for radiated spurious emission test under different RB size/offset and modulations in exploratory test. Subsequently, only the worst case emissions are reported. 															



Test Items	Band	Bandwidth (MHz)										Modulation			RB #			Test Channel			
		5+20	10+15	10+20	15+10	15+15	15+20	20+5	20+10	20+15	20+20	QPSK	16QAM	64QAM	1	Half	Full	L	M	H	
Max. Output Power	CA_41C	v	v	v	v	v	v	v	v	v	v	v	v	v	v	v	v	v	v	v	
26dB and 99% Bandwidth	CA_41C	v	v	v	v	v	v	v	v	v	v	v	v	v			v	v	v	v	
Conducted Band Edge	CA_41C	v	v	v	v	v	v	v	v	v	v	v	v	v		v	v		v		
Conducted Spurious Emission	CA_41C	v	v	v	v	v	v	v	v	v	v	v	v	v				v	v	v	
E.I.R.P.	CA_41C	v	v	v	v	v	v	v	v	v	v	v	v	v				v	v	v	
Radiated Spurious Emission	CA_41C	Worst Case																			v
Note	<ol style="list-style-type: none"> The mark "v" means that this configuration is chosen for testing The mark "-" means that this bandwidth is not supported. The device is investigated from 30MHz to 10 times of fundamental signal for radiated spurious emission test under different RB size/offset and modulations in exploratory test. Subsequently, only the worst case emissions are reported. 																				

2.2 Connection Diagram of Test System

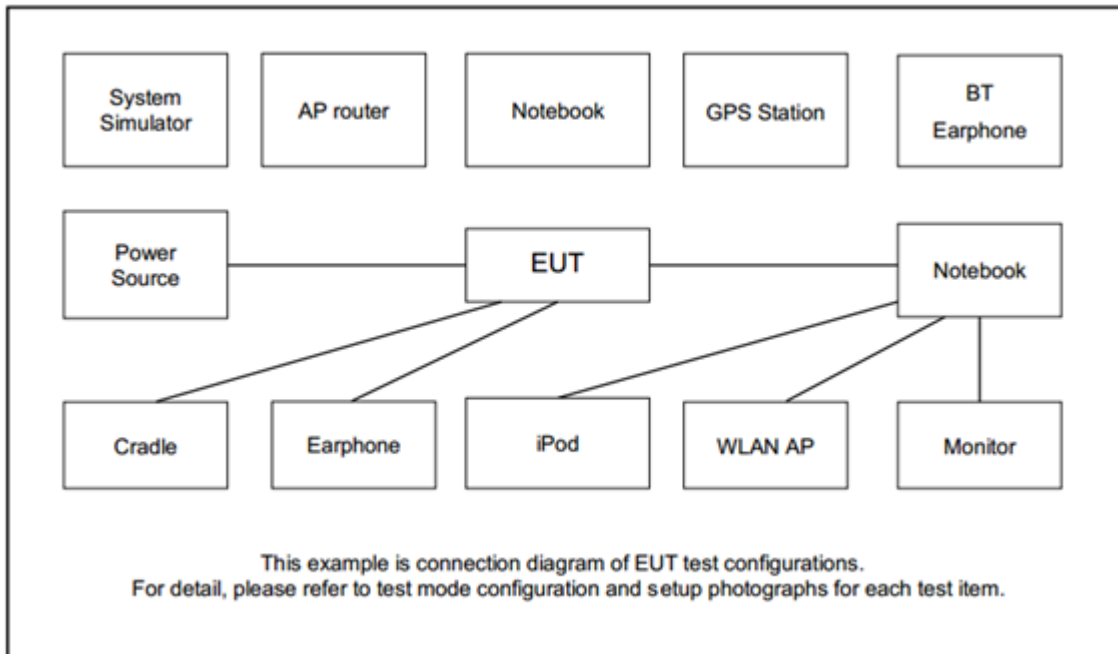

2.3 Support Unit used in test configuration and system

Item	Equipment	Trade Name	Model No.	FCC ID	Data Cable	Power Cord
1.	System Simulator	Anritsu	MT8820C	N/A	N/A	Unshielded, 1.8 m
2.	DC Power Supply	GW INSTRON	GPS-3030D	N/A	N/A	Unshielded, 1.8m

2.4 Measurement Results Explanation Example

For all conducted test items:

The offset level is set in the spectrum analyzer to compensate the RF cable loss between EUT conducted output port and spectrum analyzer. With the offset compensation, the spectrum analyzer reading level is exactly the EUT RF output level.

The spectrum analyzer offset is derived from RF cable loss.

Offset = RF cable loss.

Following shows an offset computation example with cable loss 4.5 dB.

Example :

$$\begin{aligned} \text{Offset(dB)} &= \text{RF cable loss(dB)} \\ &= 4.5 \text{ (dB)} \end{aligned}$$



2.5 Frequency List of Low/Middle/High Channels

LTE Band 13 Channel and Frequency List				
BW [MHz]	Channel/Frequency(MHz)	Lowest	Middle	Highest
10	Channel	-	23230	-
	Frequency	-	782	-
5	Channel	23205	23230	23255
	Frequency	779.5	782	784.5

LTE Band CA_41C Channel and Frequency List					
BW [MHz]	Channel/Frequency(MHz)	Lowest	Middle	Highest	
20 + 20	PCC	Channel	39750	40521	41292
		Frequency	2506.0	2583.1	2660.2
	SCC	Channel	39948	40719	41490
		Frequency	2525.8	2602.9	2680.0
20 + 15	PCC	Channel	39750	40546	41341
		Frequency	2506.0	2585.6	2665.1
	SCC	Channel	39921	40717	41512
		Frequency	2523.1	2602.7	2682.2
15 + 20	PCC	Channel	39728	40523	41319
		Frequency	2503.8	2593.3	2662.9
	SCC	Channel	39899	40694	41490
		Frequency	2520.9	2600.4	2680.0
20 + 10	PCC	Channel	39750	40571	41391
		Frequency	2506.0	2588.1	2670.1
	SCC	Channel	39894	40715	41535
		Frequency	2520.4	2602.5	2684.5
10 + 20	PCC	Channel	39705	40526	41346
		Frequency	2501.5	2583.6	2665.6
	SCC	Channel	39849	40670	41490
		Frequency	2515.9	2598.0	2680.0



LTE Band CA_41C Channel and Frequency List					
20 + 5	PCC	Channel	39750	40595	41440
		Frequency	2506.0	2590.5	2675.0
	SCC	Channel	39867	40712	41557
		Frequency	2517.7	2602.2	2686.7
5 + 20	PCC	Channel	39683	40528	41373
		Frequency	2499.3	2583.8	2668.3
	SCC	Channel	39800	40645	41490
		Frequency	2511.0	2595.5	2680.0
15 + 15	PCC	Channel	39725	40545	41365
		Frequency	2503.5	2585.5	2667.5
	SCC	Channel	39875	40695	41515
		Frequency	2518.5	2600.5	2682.5
10 + 15	PCC	Channel	39703	40549	41395
		Frequency	2501.3	2585.9	2670.5
	SCC	Channel	39823	40669	41515
		Frequency	2513.3	2597.9	2682.5
15 + 10	PCC	Channel	39725	40571	41417
		Frequency	2503.5	2588.1	2672.7
	SCC	Channel	39845	40691	41537
		Frequency	2515.5	2600.1	2684.7

3 Conducted Test Items

3.1 Measuring Instruments

See list of measuring instruments of this test report.

3.2 Test Setup

3.2.1 Conducted Output Power

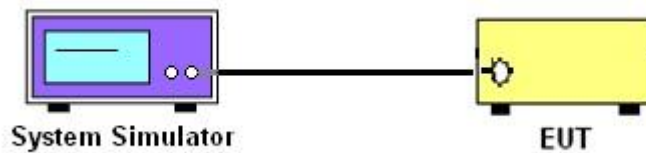

3.2.2 Peak-to-Average Ratio, Occupied Bandwidth ,Conducted Band-Edge and Conducted Spurious Emission

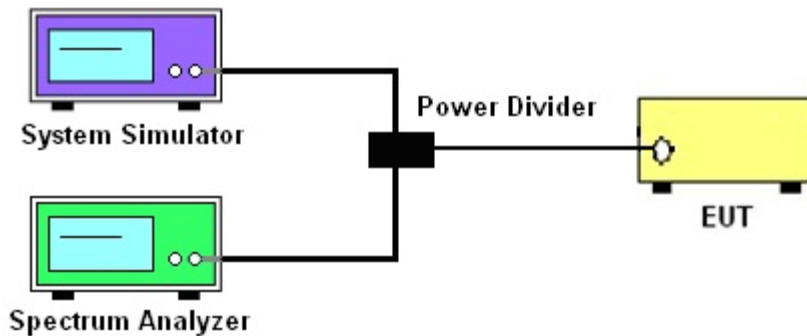

3.2.3 Frequency Stability

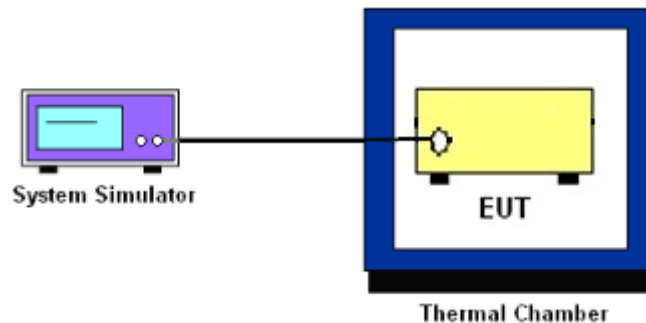

3.3 Test Result of Conducted Test

Please refer to Appendix A.



3.4 Conducted Output Power and ERP/EIRP

3.4.1 Description of the Conducted Output Power Measurement and ERP/EIRP Measurement

A system simulator was used to establish communication with the EUT. Its parameters were set to force the EUT transmitting at maximum output power. The measured power in the radio frequency on the transmitter output terminals shall be reported.

The ERP of mobile transmitters must not exceed 3 Watts for Band 13.

The EIRP of mobile transmitters must not exceed 2 Watts for Band 41.

According to KDB 412172 D01 Power Approach,

$EIRP = P_T + G_T - L_C$, $ERP = EIRP - 2.15$, where

P_T = transmitter output power in dBm

G_T = gain of the transmitting antenna in dBi

L_C = signal attenuation in the connecting cable between the transmitter and antenna in dB

3.4.2 Test Procedures

1. The testing follows ANSI C63.26 Section 5.2
2. The transmitter output port was connected to the system simulator.
3. Set EUT at maximum power through the system simulator.
4. Select lowest, middle, and highest channels for each band and different modulation.
5. Measure and record the power level from the system simulator.



3.5 Peak-to-Average Ratio

3.5.1 Description of the PAR Measurement

Power Complementary Cumulative Distribution Function (CCDF) curves provide a means for characterizing the power peaks of a digitally modulated signal on a statistical basis. A CCDF curve depicts the probability of the peak signal amplitude exceeding the average power level. Most contemporary measurement instrumentation include the capability to produce CCDF curves for an input signal provided that the instrument's resolution bandwidth can be set wide enough to accommodate the entire input signal bandwidth. In measuring transmissions in this band using an average power technique, the peak-to-average ratio (PAR) of the transmission may not exceed 13 dB.

3.5.2 Test Procedures

1. The testing follows ANSI C63.26 Section 5.2.3.4 (CCDF).
2. The EUT was connected to spectrum and system simulator via a power divider.
3. Set the CCDF (Complementary Cumulative Distribution Function) option in spectrum analyzer.
4. The highest RF powers were measured and recorded the maximum PAPR level associated with a probability of 0.1 %.
5. Record the deviation as Peak to Average Ratio.



3.6 Occupied Bandwidth

3.6.1 Description of Occupied Bandwidth Measurement

The occupied bandwidth is the width of a frequency band such that, below the lower and above the upper frequency limits, the mean powers emitted are each equal to a specified percentage 0.5% of the total mean transmitted power.

The 26 dB emission bandwidth is defined as the frequency range between two points, one above and one below the carrier frequency, at which the spectral density of the emission is attenuated 26 dB below the maximum in-band spectral density of the modulated signal. Spectral density (power per unit bandwidth) is to be measured with a detector of resolution bandwidth equal to approximately 1.0% of the emission bandwidth.

3.6.2 Test Procedures

1. The testing follows ANSI C63.26 Section 5.4
2. The EUT was connected to spectrum analyzer and system simulator via a power divider.
3. The spectrum analyzer center frequency is set to the nominal EUT channel center frequency. The span range for the spectrum analyzer shall be between two and five times the anticipated OBW.
4. The nominal resolution bandwidth (RBW) shall be in the range of 1 to 5 % of the anticipated OBW, and the VBW shall be at least 3 times the RBW.
5. Set the detection mode to peak, and the trace mode to max hold.
6. Determine the reference value: Set the EUT to transmit a modulated signal. Allow the trace to stabilize. Set the spectrum analyzer marker to the highest level of the displayed trace.
(this is the reference value)
7. Determine the “-26 dB down amplitude” as equal to (Reference Value – X).
8. Place two markers, one at the lowest and the other at the highest frequency of the envelope of the spectral display such that each marker is at or slightly below the “-X dB down amplitude” determined in step 6. If a marker is below this “-X dB down amplitude” value it shall be placed as close as possible to this value. The OBW is the positive frequency difference between the two markers.
9. Use the 99 % power bandwidth function of the spectrum analyzer and report the measured bandwidth.



3.7 Conducted Band Edge

3.7.1 Description of Conducted Band Edge Measurement

27.53 (c)

For operations in the 776-788 MHz band, the FCC limit is $43 + 10\log_{10}(P[\text{Watts}])$ dB below the transmitter power P(Watts) in a 100 kHz bandwidth. However, in the 100 kHz bands immediately outside and adjacent to the frequency block, a resolution bandwidth of at least 30 kHz may be employed. In addition, the power of any unwanted emissions in any 6.25 kHz bandwidth for all frequencies between 763-775 MHz and 793-806 MHz shall be attenuated below the transmitter power, P (dBW), by at least $65 + 10 \log_{10} p(\text{watts})$, dB, for mobile and portable equipment.

27.53(m)(4)

For mobile digital stations, the attenuation factor shall be not less than $40 + 10 \log (P)$ dB on all frequencies between the channel edge and 5 megahertz from the channel edge, $43 + 10 \log (P)$ dB on all frequencies between 5 megahertz and X megahertz from the channel edge, and $55 + 10 \log (P)$ dB on all frequencies more than X megahertz from the channel edge, where X is the greater of 6 megahertz or the actual emission bandwidth as defined in paragraph (m)(6) of this section. In addition, the attenuation factor shall not be less that $43 + 10 \log (P)$ dB on all frequencies between 2490.5 MHz and 2496 MHz and $55 + 10 \log (P)$ dB at or below 2490.5 MHz. Mobile Satellite Service licensees operating on frequencies below 2495 MHz may also submit a documented interference complaint against BRS licensees operating on channel BRS Channel 1 on the same terms and conditions as adjacent channel BRS or EBS licensees.



3.7.2 Test Procedures

1. The testing follows ANSI C63.26 section 5.7
2. The EUT was connected to spectrum analyzer and system simulator via a power divider.
3. The band edges of low and high channels for the highest RF powers were measured.
4. Set RBW \geq 1% EBW in the 1MHz band immediately outside and adjacent to the band edge.
5. Beyond the 1 MHz band from the band edge, RBW=1MHz was used or a narrower RBW was used and the measured power was integrated over the full required measurement bandwidth of 1 MHz.
6. Set spectrum analyzer with RMS detector.
7. The RF fundamental frequency should be excluded against the limit line in the operating frequency band.
8. Checked that all the results comply with the emission limit line.

Example:

The limit line is derived from $43 + 10\log(P)$ dB below the transmitter power P(Watts)

$$= P(W) - [43 + 10\log(P)] \text{ (dB)}$$

$$= [30 + 10\log(P)] \text{ (dBm)} - [43 + 10\log(P)] \text{ (dB)} = -13\text{dBm.}$$

9. For LTE Band 41, the other 40 dB, and 55 dB have additionally applied same calculation above.



3.8 Conducted Spurious Emission

3.8.1 Description of Conducted Spurious Emission Measurement

The power of any emission outside of the authorized operating frequency ranges must be lower than the transmitter power (P) by a factor of at least $43 + 10 \log (P)$ dB.

For Band 41:

The power of any emission outside of the authorized operating frequency ranges must be lower than the transmitter power (P) by a factor of at least $55 + 10 \log (P)$ dB.

It is measured by means of a calibrated spectrum analyzer and scanned from 30 MHz up to a frequency including its 10th harmonic.

3.8.2 Test Procedures

1. The testing follows ANSI C63.26 section 5.7
2. The EUT was connected to spectrum analyzer and system simulator via a power divider.
3. The RF output of EUT was connected to the spectrum analyzer by RF cable and attenuator. The path loss was compensated to the results for each measurement.
4. The middle channel for the highest RF power within the transmitting frequency was measured.
5. The conducted spurious emission for the whole frequency range was taken.
6. Make the measurement with the spectrum analyzer's RBW = 1MHz, VBW = 3MHz.
7. Set spectrum analyzer with RMS detector.
8. Taking the record of maximum spurious emission.
9. The RF fundamental frequency should be excluded against the limit line in the operating frequency band.
10. The limit line is derived from $43 + 10\log(P)$ dB below the transmitter power P(Watts)
 $= P(W) - [43 + 10\log(P)]$ (dB)
 $= [30 + 10\log(P)]$ (dBm) - $[43 + 10\log(P)]$ (dB)
 $= -13$ dBm.
11. For Band 41
The limit line is derived from $55 + 10\log(P)$ dB below the transmitter power P(Watts)
 $= P(W) - [55 + 10\log(P)]$ (dB)
 $= [30 + 10\log(P)]$ (dBm) - $[55 + 10\log(P)]$ (dB)
 $= -25$ dBm.



3.9 Frequency Stability

3.9.1 Description of Frequency Stability Measurement

The frequency stability shall be measured by variation of ambient temperature and variation of primary supply voltage to ensure that the fundamental emission stays within the authorized frequency block. The frequency stability of the transmitter shall be maintained within $\pm 0.00025\%$ ($\pm 2.5\text{ppm}$) of the center frequency.

3.9.2 Test Procedures for Temperature Variation

1. The testing follows ANSI C63.26 section 5.6.4
2. The EUT was set up in the thermal chamber and connected with the system simulator.
3. With power OFF, the temperature was decreased to -30°C and the EUT was stabilized before testing. Power was applied and the maximum change in frequency was recorded within one minute.
4. With power OFF, the temperature was raised in 10°C step up to 50°C . The EUT was stabilized at each step for at least half an hour. Power was applied and the maximum frequency change was recorded within one minute.

3.9.3 Test Procedures for Voltage Variation

1. The testing follows ANSI C63.26 section 5.6.5
2. The EUT was placed in a temperature chamber at $20\pm 5^{\circ}\text{C}$ and connected with the system simulator.
3. The power supply voltage to the EUT was varied from 85% to 115% of the nominal value for other than hand carried battery equipment.
4. For hand carried, battery powered equipment, reduce the primary ac or dc supply voltage to the battery operating end point, which shall be specified by the manufacturer.
5. The variation in frequency was measured for the worst case.

4 Radiated Test Items

4.1 Measuring Instruments

See list of measuring instruments of this test report.

4.2 Test Setup

4.2.1 For radiated test from 30MHz to 1GHz

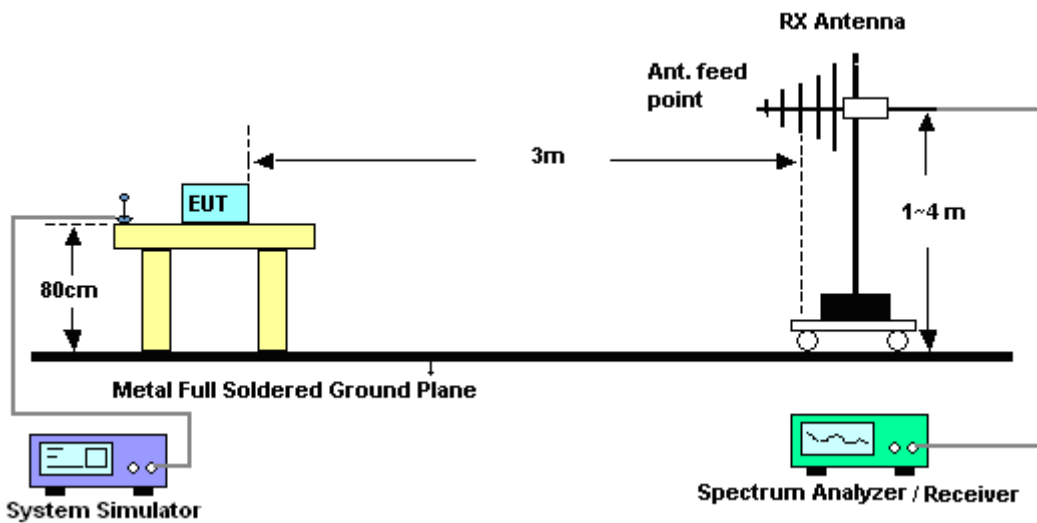

4.2.2 For radiated test above 1GHz

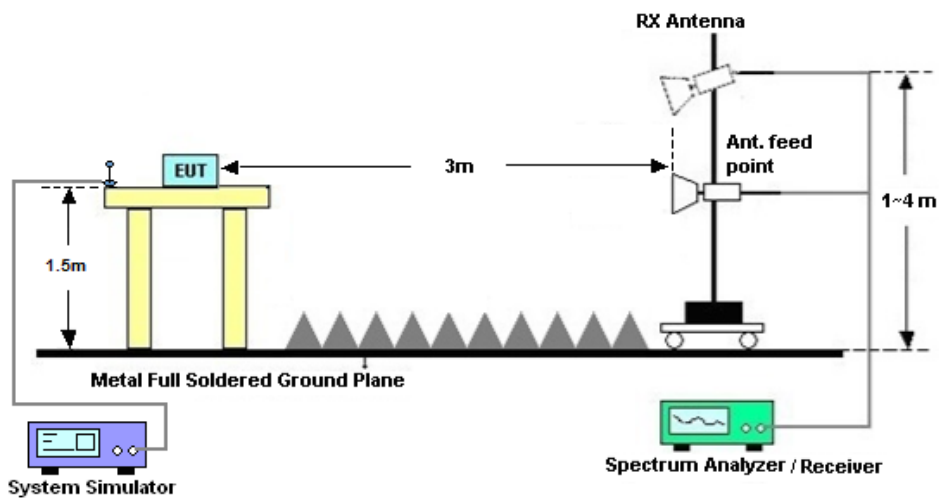

4.3 Test Result of Radiated Test

Please refer to Appendix B.



4.4 Radiated Spurious Emission

4.4.1 Description of Radiated Spurious Emission

The radiated spurious emission was measured by substitution method according to ANSI C63.26. The power of any emission outside of the authorized operating frequency ranges must be attenuated below the transmitter power (P) by a factor of at least $43 + 10 \log (P)$ dB.

For Band 41

The power of any emission outside of the authorized operating frequency ranges must be attenuated below the transmitter power (P) by a factor of at least $55 + 10 \log (P)$ dB.

For LTE Band 13

For operations in the 746-758 MHz, 775-788 MHz, and 805-806 MHz bands, emissions in the band 1559-1610 MHz shall be limited to -70 dBW/MHz equivalent isotropically radiated power (EIRP) for wideband signals, and -80 dBW EIRP for discrete emissions of less than 700 Hz bandwidth.

The spectrum is scanned from 30 MHz up to a frequency including its 10th harmonic.

4.4.2 Test Procedures

1. The testing follows ANSI C63.26 Section 5.5
2. The EUT was placed on a turntable with 0.8 meter height for frequency below 1GHz and 1.5 meter height for frequency above 1GHz respectively above ground.
3. The EUT was set 3 meters from the receiving antenna mounted on the antenna tower.
4. The table was rotated 360 degrees to determine the position of the highest spurious emission.
5. The height of the receiving antenna is varied between 1m to 4m to search the maximum spurious emission for both horizontal and vertical polarizations.
6. During the measurement, the system simulator parameters were set to force the EUT transmitting at maximum output power.
7. Make the measurement with the spectrum analyzer's RBW = 1MHz, VBW = 3MHz, taking the record of maximum spurious emission.
8. A horn antenna was substituted in place of the EUT and was driven by a signal generator.
9. Tune the output power of signal generator to the same emission level with EUT maximum spurious emission.
10. $EIRP (dBm) = S.G. Power - Tx Cable Loss + Tx Antenna Gain$
11. $ERP (dBm) = EIRP - 2.15$
12. The RF fundamental frequency should be excluded against the limit line in the operating frequency band.
The limit line is derived from $43 + 10\log(P)$ dB below the transmitter power P(Watts)
 $= P(W) - [43 + 10\log(P)] (dB)$
 $= [30 + 10\log(P)] (dBm) - [43 + 10\log(P)] (dB)$
 $= -13dBm.$
13. For Band 41:
The limit line is derived from $55 + 10\log(P)$ dB below the transmitter power P(Watts)



5 List of Measuring Equipment

Instrument	Manufacturer	Model No.	Serial No.	Characteristics	Calibration Date	Test Date	Due Date	Remark
Spectrum Analyzer	R&S	FSV40	100319	10Hz~40GHz	Oct. 11, 2018	Mar. 01, 2019~ Mar. 25, 2019	Oct. 10, 2019	Conducted (TH01-KS)
Temperature & humidity chamber	Hongzhan	LP-150U	H2014011440	-40~+150°C 20%~95%RH	Jun. 27, 2018	Mar. 01, 2019~ Mar. 25, 2019	Jun. 26, 2019	Conducted (TH01-KS)
EXA Spectrum Analyzer	Keysight	N9010B	MY57471084	10Hz-44GHz	Jun. 25, 2018	Mar. 26, 2019	Jun. 24, 2019	Radiation (03CH06-KS)
Bilog Antenna	TeseQ	CBL6111D	44483	30MHz-1GHz	Dec. 28, 2018	Mar. 26, 2019	Dec. 27, 2019	Radiation (03CH06-KS)
Double Ridge Horn Antenna	ETS-Lindgren	3117	75957	1GHz~18GHz	Oct. 20, 2018	Mar. 26, 2019	Oct. 19, 2019	Radiation (03CH06-KS)
SHF-EHF Horn	Com-power	AH-840	101070	18GHz~40GHz	Jan. 05, 2019	Mar. 26, 2019	Jan. 04, 2020	Radiation (03CH06-KS)
Amplifier	SONOMA	310N	187289	9KHz ~1GHZ	Aug. 06, 2018	Mar. 26, 2019	Aug. 05, 2019	Radiation (03CH06-KS)
Amplifier	MITEQ	TTA1840-35-HG	2014749	18~40GHz	Jan. 14, 2019	Mar. 26, 2019	Jan. 13, 2020	Radiation (03CH06-KS)
high gain Amplifier	MITEQ	AMF-7D-00 101800-30-1	2025788	1Ghz-18Ghz	Apr. 17, 2018	Mar. 26, 2019	Apr. 16, 2019	Radiation (03CH06-KS)
Amplifier	Keysight	83017A	MY53270203	500MHz~26.5GHz	Apr. 18, 2018	Mar. 26, 2019	Apr. 17, 2019	Radiation (03CH06-KS)
AC Power Source	Chroma	61601	F104090004	N/A	NCR	Mar. 26, 2019	NCR	Radiation (03CH06-KS)
Turn Table	ChamPro	EM 1000-T	060762-T	0~360 degree	NCR	Mar. 26, 2019	NCR	Radiation (03CH06-KS)
Antenna Mast	ChamPro	EM 1000-A	060762-A	1 m~4 m	NCR	Mar. 26, 2019	NCR	Radiation (03CH06-KS)



6 Uncertainty of Evaluation

The measurement uncertainties shown below were calculated in accordance with the requirements of ANSI 63.26-2015. All the measurement uncertainty value were shown with a coverage K=2 to indicate 95% level of confidence. The measurement data show herein meets or exceeds the CISPR measurement uncertainty values specified in CISPR 16-4-2 and can be compared directly to specified limit to determine compliance.

Uncertainty of Radiated Emission Measurement (30 MHz ~ 1000 MHz)

Measuring Uncertainty for a Level of Confidence of 95% (U = 2Uc(y))	2.5 dB
---	--------

Uncertainty of Radiated Emission Measurement (1 GHz ~ 40 GHz)

Measuring Uncertainty for a Level of Confidence of 95% (U = 2Uc(y))	2.0 dB
---	--------



Appendix A. Test Results of Conducted Test

Conducted Output Power(Average power)

LTE Band 13 Maximum Average Power [dBm]						
BW [MHz]	RB Size	RB Offset	Mod	Lowest	Middle	Highest
10	1	0	QPSK		22.92	
10	1	25			22.78	
10	1	49			22.88	
10	25	0			21.74	
10	25	12			21.79	
10	25	25			21.84	
10	50	0			21.87	
10	1	0	16-QAM		22.17	
10	1	25			22.02	
10	1	49			22.19	
10	25	0			20.67	
10	25	12			20.72	
10	25	25			20.85	
10	50	0			20.89	
10	1	0	64-QAM		20.97	
10	1	25			20.87	
10	1	49			21.09	
10	25	0			19.74	
10	25	12			19.74	
10	25	25			19.85	
10	50	0			19.86	
5	1	0	QPSK	22.76	22.78	22.70
5	1	12		22.74	22.72	22.69
5	1	24		22.80	22.66	22.69
5	12	0		21.82	21.78	21.72
5	12	7		21.93	21.75	21.77
5	12	13		21.79	21.68	21.76
5	25	0		21.86	21.78	21.80



5	1	0	16-QAM	22.04	21.97	21.99
5	1	12		21.96	21.96	21.99
5	1	24		22.08	21.91	21.91
5	12	0		20.82	20.79	20.80
5	12	7		20.92	20.78	20.83
5	12	13		20.82	20.73	20.80
5	25	0		20.73	20.73	20.76
5	1	0	64-QAM	20.77	20.80	20.87
5	1	12		21.01	20.76	20.87
5	1	24		21.01	20.75	20.79
5	12	0		19.73	19.74	19.68
5	12	7		19.84	19.73	19.80
5	12	13		19.78	19.70	19.77
5	25	0		19.79	19.75	19.80



CA Power

CA_41C								
Combination 20MHz+20MHz (100RB+100RB)								
PCC Channel	SCC Channel	Modulation	PCC		SCC		Total RB Size	Measured Power (dBm)
			RB Size	RB offset	RB Size	RB offset		
39750	39948	QPSK	100	0	100	0	200	22.32
			1	0	1	99	2	16.41
			1	99	1	0	2	22.72
		16QAM	100	0	100	0	200	20.47
			1	0	1	99	2	16.82
			1	99	1	0	2	22.07
		64QAM	100	0	100	0	200	20.37
			1	0	1	99	2	16.09
			1	99	1	0	2	19.59
40521	40719	QPSK	100	0	100	0	200	21.32
			1	0	1	99	2	16.6
			1	99	1	0	2	22.78
		16QAM	100	0	100	0	200	20.46
			1	0	1	99	2	16.41
			1	99	1	0	2	21.66
		64QAM	100	0	100	0	200	20.41
			1	0	1	99	2	16.33
			1	99	1	0	2	19.37
41292	41490	QPSK	100	0	100	0	200	21.18
			1	0	1	99	2	16.51
			1	99	1	0	2	22.58
		16QAM	100	0	100	0	200	20.3
			1	0	1	99	2	16.56
			1	99	1	0	2	21.38
		64QAM	100	0	100	0	200	20.25
			1	0	1	99	2	15.77
			1	99	1	0	2	19.1



CA_41C								
Combination 20MHz+15MHz (100RB+75RB)								
PCC Channel	SCC Channel	Modulation	PCC		SCC		Total RB Size	Measured Power (dBm)
			RB Size	RB offset	RB Size	RB offset		
39750	39921	QPSK	100	0	75	0	175	21.12
		QPSK	1	0	1	74	2	15.71
		QPSK	1	99	1	0	2	22.59
		16QAM	100	0	75	0	175	20.15
		16QAM	1	0	1	74	2	15.61
		16QAM	1	99	1	0	2	21.8
		64QAM	100	0	75	0	175	19.85
		64QAM	1	0	1	74	2	15.05
		64QAM	1	99	1	0	2	19.33
40546	40717	QPSK	100	0	75	0	175	20.89
		QPSK	1	0	1	74	2	15.48
		QPSK	1	99	1	0	2	22.51
		16QAM	100	0	75	0	175	20.08
		16QAM	1	0	1	74	2	15.48
		16QAM	1	99	1	0	2	21.4
		64QAM	100	0	75	0	175	19.96
		64QAM	1	0	1	74	2	15
		64QAM	1	99	1	0	2	21.36
41341	41512	QPSK	100	0	75	0	175	21.65
		QPSK	1	0	1	74	2	15.99
		QPSK	1	99	1	0	2	22.55
		16QAM	100	0	75	0	175	20.65
		16QAM	1	0	1	74	2	16.04
		16QAM	1	99	1	0	2	21.18
		64QAM	100	0	75	0	175	20.61
		64QAM	1	0	1	74	2	15.98
		64QAM	1	99	1	0	2	21.25



Combination 15MHz+20MHz (75RB+100RB)								
PCC Channel	SCC Channel	Modulation	PCC		SCC		Total RB Size	Measured Power (dBm)
			RB Size	RB offset	RB Size	RB offset		
39728	39899	QPSK	75	0	100	0	175	21.3
		QPSK	1	0	1	99	2	15.54
		QPSK	1	74	1	0	2	22.37
		16QAM	75	0	100	0	175	20.35
		16QAM	1	0	1	99	2	15.59
		16QAM	1	74	1	0	2	21.86
		64QAM	75	0	100	0	175	20.2
		64QAM	1	0	1	99	2	15.36
		64QAM	1	74	1	0	2	20
40523	40694	QPSK	75	0	100	0	175	20.99
		QPSK	1	0	1	99	2	15.44
		QPSK	1	74	1	0	2	22.55
		16QAM	75	0	100	0	175	20.04
		16QAM	1	0	1	99	2	15.54
		16QAM	1	74	1	0	2	21.6
		64QAM	75	0	100	0	175	20.07
		64QAM	1	0	1	99	2	15.65
		64QAM	1	74	1	0	2	19.41
41319	41490	QPSK	75	0	100	0	175	20.65
		QPSK	1	0	1	99	2	15.46
		QPSK	1	74	1	0	2	22.65
		16QAM	75	0	100	0	175	20.01
		16QAM	1	0	1	99	2	15.41
		16QAM	1	74	1	0	2	21.41
		64QAM	75	0	100	0	175	20.16
		64QAM	1	0	1	99	2	15.34
		64QAM	1	74	1	0	2	20



Combination 20MHz+10MHz (100RB+50RB)								
PCC	SCC	Modulation	PCC		SCC		Total RB Size	Measured Power (dBm)
Channel	Channel		RB Size	RB offset	RB Size	RB offset		
39750	39894	QPSK	100	0	50	0	150	20.81
		QPSK	1	0	1	49	2	15.55
		QPSK	1	99	1	0	2	22.96
		16QAM	100	0	50	0	150	19.92
		16QAM	1	0	1	49	2	15.35
		16QAM	1	99	1	0	2	21.77
		64QAM	100	0	50	0	150	20.26
		64QAM	1	0	1	49	2	15.18
		64QAM	1	99	1	0	2	19.54
40571	40715	QPSK	100	0	50	0	150	20.78
		QPSK	1	0	1	49	2	15.34
		QPSK	1	99	1	0	2	22.91
		16QAM	100	0	50	0	150	19.95
		16QAM	1	0	1	49	2	15.41
		16QAM	1	99	1	0	2	21.84
		64QAM	100	0	50	0	150	19.84
		64QAM	1	0	1	49	2	15.65
		64QAM	1	99	1	0	2	19.55
41391	41535	QPSK	100	0	50	0	150	20.87
		QPSK	1	0	1	49	2	15.45
		QPSK	1	99	1	0	2	22.99
		16QAM	100	0	50	0	150	19.61
		16QAM	1	0	1	49	2	15.56
		16QAM	1	99	1	0	2	21.74
		64QAM	100	0	50	0	150	19.88
		64QAM	1	0	1	49	2	15.41
		64QAM	1	99	1	0	2	19.74



Combination 10MHz+20MHz (50RB+100RB)								
PCC	SCC	Modulation	PCC		SCC		Total RB Size	Measured Power (dBm)
Channel	Channel		RB Size	RB offset	RB Size	RB offset		
39705	39849	QPSK	50	0	100	0	150	21.28
		QPSK	1	0	1	99	2	15.3
		QPSK	1	49	1	0	2	23.05
		16QAM	50	0	100	0	150	20.34
		16QAM	1	0	1	99	2	15.34
		16QAM	1	49	1	0	2	21.88
		64QAM	50	0	100	0	150	20.31
		64QAM	1	0	1	99	2	15.28
		64QAM	1	49	1	0	2	19.78
40526	40670	QPSK	50	0	100	0	150	21.05
		QPSK	1	0	1	99	2	15.32
		QPSK	1	49	1	0	2	22.89
		16QAM	50	0	100	0	150	20.01
		16QAM	1	0	1	99	2	15.41
		16QAM	1	49	1	0	2	22.05
		64QAM	50	0	100	0	150	19.98
		64QAM	1	0	1	99	2	15.34
		64QAM	1	49	1	0	2	19.98
41346	41490	QPSK	50	0	100	0	150	21.07
		QPSK	1	0	1	99	2	15.34
		QPSK	1	49	1	0	2	23
		16QAM	50	0	100	0	150	20.08
		16QAM	1	0	1	99	2	15.41
		16QAM	1	49	1	0	2	21.87
		64QAM	50	0	100	0	150	20.12
		64QAM	1	0	1	99	2	15.36
		64QAM	1	49	1	0	2	19.84



Combination 20MHz+5MHz (100RB+25RB)								
PCC	SCC	Modulation	PCC		SCC		Total RB Size	Measured Power (dBm)
Channel	Channel		RB Size	RB offset	RB Size	RB offset		
39750	39867	QPSK	100	0	25	0	125	21.05
		QPSK	1	0	1	24	2	14.89
		QPSK	1	99	1	0	2	22.51
		16QAM	100	0	25	0	125	19.84
		16QAM	1	0	1	24	2	15.28
		16QAM	1	99	1	0	2	21.54
		64QAM	100	0	25	0	125	20.01
		64QAM	1	0	1	24	2	15.07
		64QAM	1	99	1	0	2	19.38
40595	40712	QPSK	100	0	25	0	125	20.65
		QPSK	1	0	1	24	2	15.22
		QPSK	1	99	1	0	2	22.97
		16QAM	100	0	25	0	125	19.87
		16QAM	1	0	1	24	2	15.12
		16QAM	1	99	1	0	2	21.95
		64QAM	100	0	25	0	125	20.04
		64QAM	1	0	1	24	2	14.94
		64QAM	1	99	1	0	2	19.04
41440	41557	QPSK	100	0	25	0	125	20.67
		QPSK	1	0	1	24	2	15.2
		QPSK	1	99	1	0	2	22.57
		16QAM	100	0	25	0	125	19.89
		16QAM	1	0	1	24	2	15.23
		16QAM	1	99	1	0	2	20.72
		64QAM	100	0	25	0	125	19.88
		64QAM	1	0	1	24	2	15.11
		64QAM	1	99	1	0	2	19.16



Combination 5MHz+20MHz (25RB+100RB)								
PCC	SCC	Modulation	PCC		SCC		Total RB Size	Measured Power (dBm)
Channel	Channel		RB Size	RB offset	RB Size	RB offset		
39683	39800	QPSK	25	0	100	0	125	21.28
		QPSK	1	0	1	99	2	15
		QPSK	1	24	1	0	2	23.33
		16QAM	25	0	100	0	125	20.15
		16QAM	1	0	1	99	2	15.09
		16QAM	1	24	1	0	2	21.75
		64QAM	25	0	100	0	125	20.27
		64QAM	1	0	1	99	2	15.13
		64QAM	1	24	1	0	2	20.22
40528	40645	QPSK	25	0	100	0	125	21.11
		QPSK	1	0	1	99	2	15.11
		QPSK	1	24	1	0	2	23.34
		16QAM	25	0	100	0	125	20.18
		16QAM	1	0	1	99	2	15.11
		16QAM	1	24	1	0	2	22.4
		64QAM	25	0	100	0	125	20.15
		64QAM	1	0	1	99	2	15.13
		64QAM	1	24	1	0	2	19.39
41373	41490	QPSK	25	0	100	0	125	21.61
		QPSK	1	0	1	99	2	15.12
		QPSK	1	24	1	0	2	23.04
		16QAM	25	0	100	0	125	20.52
		16QAM	1	0	1	99	2	15.11
		16QAM	1	24	1	0	2	21.34
		64QAM	25	0	100	0	125	20.52
		64QAM	1	0	1	99	2	14.64
		64QAM	1	24	1	0	2	20.94



Combination 15MHz+15MHz (75RB+75RB)								
PCC	SCC	Modulation	PCC		SCC		Total RB Size	Measured Power (dBm)
Channel	Channel		RB Size	RB offset	RB Size	RB offset		
39725	39875	QPSK	75	0	75	0	150	21.07
		QPSK	1	0	1	74	2	15.32
		QPSK	1	74	1	0	2	22.65
		16QAM	75	0	75	0	150	21.17
		16QAM	1	0	1	74	2	15.21
		16QAM	1	74	1	0	2	21.83
		64QAM	75	0	75	0	150	20.37
		64QAM	1	0	1	74	2	15.44
		64QAM	1	74	1	0	2	19.53
40545	40695	QPSK	75	0	75	0	150	20.84
		QPSK	1	0	1	74	2	15.03
		QPSK	1	74	1	0	2	22.34
		16QAM	75	0	75	0	150	19.88
		16QAM	1	0	1	74	2	15.01
		16QAM	1	74	1	0	2	21.54
		64QAM	75	0	75	0	150	19.93
		64QAM	1	0	1	74	2	14.93
		64QAM	1	74	1	0	2	19.16
41365	41515	QPSK	75	0	75	0	150	21.09
		QPSK	1	0	1	74	2	14.99
		QPSK	1	74	1	0	2	22.9
		16QAM	75	0	75	0	150	20.13
		16QAM	1	0	1	74	2	15.02
		16QAM	1	74	1	0	2	21.15
		64QAM	75	0	75	0	150	20.23
		64QAM	1	0	1	74	2	15.01
		64QAM	1	74	1	0	2	19.05



Combination 15MHz+10MHz (75RB+50RB)								
PCC	SCC	Modulation	PCC		SCC		Total RB Size	Measured Power (dBm)
Channel	Channel		RB Size	RB offset	RB Size	RB offset		
39725	39845	QPSK	75	0	50	0	125	21.3
		QPSK	1	0	1	49	2	14.98
		QPSK	1	74	1	0	2	23.15
		16QAM	75	0	50	0	125	23.25
		16QAM	1	0	1	49	2	15.09
		16QAM	1	74	1	0	2	21.9
		64QAM	75	0	50	0	125	21.53
		64QAM	1	0	1	49	2	14.93
		64QAM	1	74	1	0	2	21.4
40571	40691	QPSK	75	0	50	0	125	22.81
		QPSK	1	0	1	49	2	14.75
		QPSK	1	74	1	0	2	22.57
		16QAM	75	0	50	0	125	22.28
		16QAM	1	0	1	49	2	14.81
		16QAM	1	74	1	0	2	22.3
		64QAM	75	0	50	0	125	21.33
		64QAM	1	0	1	49	2	14.76
		64QAM	1	74	1	0	2	21.15
41417	41537	QPSK	75	0	50	0	125	22.81
		QPSK	1	0	1	49	2	15.18
		QPSK	1	74	1	0	2	22.42
		16QAM	75	0	50	0	125	20.79
		16QAM	1	0	1	49	2	15.17
		16QAM	1	74	1	0	2	21.04
		64QAM	75	0	50	0	125	20.78
		64QAM	1	0	1	49	2	15.03
		64QAM	1	74	1	0	2	20.83



Combination 10MHz+15MHz (50RB+75RB)								
PCC	SCC	Modulation	PCC		SCC		Total RB Size	Measured Power (dBm)
Channel	Channel		RB Size	RB offset	RB Size	RB offset		
39703	39823	QPSK	50	0	75	0	125	23.3
		QPSK	1	49	1	0	2	23.12
		QPSK	1	0	1	74	2	15.17
		16QAM	50	0	75	0	125	21.78
		16QAM	1	49	1	0	2	22
		16QAM	1	0	1	74	2	15.86
		64QAM	50	0	75	0	125	20.88
		64QAM	1	49	1	0	2	20.85
		64QAM	1	0	1	74	2	15.03
40549	40669	QPSK	50	0	75	0	125	22.95
		QPSK	1	49	1	0	2	22.73
		QPSK	1	0	1	74	2	14.81
		16QAM	50	0	75	0	125	22.32
		16QAM	1	49	1	0	2	22.48
		16QAM	1	0	1	74	2	14.81
		64QAM	50	0	75	0	125	22.38
		64QAM	1	49	1	0	2	22.06
		64QAM	1	0	1	74	2	15.09
41395	41515	QPSK	50	0	75	0	125	22.49
		QPSK	1	49	1	0	2	22.99
		QPSK	1	0	1	74	2	15
		16QAM	50	0	75	0	125	20.79
		16QAM	1	49	1	0	2	21.25
		16QAM	1	0	1	74	2	15.25
		64QAM	50	0	75	0	125	20.79
		64QAM	1	49	1	0	2	20.88
		64QAM	1	0	1	74	2	15.07



ERP/EIRP

LTE Band 13 (GT - LC = -0.10 dB) QPSK						
Bandwidth	5M			10M		
Channel	23205	23230	23255	23230		
	(Low)	(Mid)	(High)	-	(Mid)	-
Frequency	779.5	782	784.5	-	782	-
(MHz)						
Conducted Power (dBm)	22.80	22.66	22.69		22.92	-
Conducted Power (Watts)	0.1905	0.1845	0.1858		0.1959	-
ERP(dBm)	20.55	20.41	20.44		20.67	-
ERP(Watts)	0.1135	0.1099	0.1107		0.1167	-

LTE Band 13 (GT - LC = -0.10 dB) 16QAM						
Bandwidth	5M			10M		
Channel	23205	23230	23255	23230		
	(Low)	(Mid)	(High)	-	(Mid)	-
Frequency	779.5	782	784.5	-	782	-
(MHz)						
Conducted Power (dBm)	22.08	21.91	21.91		22.19	-
Conducted Power (Watts)	0.1614	0.1552	0.1552		0.1656	-
ERP(dBm)	19.83	19.66	19.66		19.94	-
ERP(Watts)	0.0962	0.0925	0.0925		0.0986	-

LTE Band 13 (GT - LC = -0.10 dB) 64QAM						
Bandwidth	5M			10M		
Channel	23205	23230	23255	23230		
	(Low)	(Mid)	(High)	-	(Mid)	-
Frequency	779.5	782	784.5	-	782	-
(MHz)						
Conducted Power (dBm)	21.01	20.76	20.87		21.09	-
Conducted Power (Watts)	0.1262	0.1191	0.1222		0.1285	-
ERP(dBm)	18.76	18.51	18.62		18.84	-
ERP(Watts)	0.0752	0.0710	0.0728		0.0766	-



CA EIRP

LTE Band 41 CA (GT - LC = 1.50 dB) QPSK									
Bandwidth	15M + 15M			5M + 20M			20M + 5M		
Channel PCC	39725	40545	41365	39683	40528	41373	39750	40595	41440
	(Low)	(Mid)	(High)	(Low)	(Mid)	(High)	(Low)	(Mid)	(High)
Channel SCC	39875	40695	41515	39800	40645	41490	39867	40712	41557
	(Low)	(Mid)	(High)	(Low)	(Mid)	(High)	(Low)	(Mid)	(High)
Conducted Power (dBm)	22.65	22.34	22.9	23.33	23.34	23.04	22.51	22.97	22.57
Conducted Power (Watts)	0.1841	0.1714	0.1950	0.2153	0.2158	0.2014	0.1782	0.1982	0.1807
EIRP(dBm)	24.15	23.84	24.40	24.83	24.84	24.54	24.01	24.47	24.07
EIRP(Watts)	0.2600	0.2421	0.2754	0.3041	0.3048	0.2844	0.2518	0.2799	0.2553

LTE Band 41 CA (GT - LC = 1.50 dB) QPSK									
Bandwidth	10M + 20M			20M + 10M			15M + 20M		
Channel PCC	39705	40526	41346	39750	40571	41391	39728	40523	41319
	(Low)	(Mid)	(High)	(Low)	(Mid)	(High)	(Low)	(Mid)	(High)
Channel SCC	39849	40670	41490	39894	40715	41535	39899	40694	41490
	(Low)	(Mid)	(High)	(Low)	(Mid)	(High)	(Low)	(Mid)	(High)
Conducted Power (dBm)	23.05	22.89	23	22.96	22.91	22.99	22.37	22.55	22.65
Conducted Power (Watts)	0.2018	0.1945	0.1995	0.1977	0.1954	0.1991	0.1726	0.1799	0.1841
EIRP(dBm)	24.55	24.39	24.50	24.46	24.41	24.49	23.87	24.05	24.15
EIRP(Watts)	0.2851	0.2748	0.2818	0.2793	0.2761	0.2812	0.2438	0.2541	0.2600



LTE Band 41 CA (GT - LC = 1.50 dB) QPSK						
Bandwidth	20M+15M			20M+20M		
Channel PCC	39750	40546	41341	39750	40521	41292
	(Low)	(Mid)	(High)	(Low)	(Mid)	(High)
Channel SCC	39921	40717	41512	39948	40719	41490
	(Low)	(Mid)	(High)	(Low)	(Mid)	(High)
Conducted Power (dBm)	22.59	22.51	22.55	22.72	22.78	22.58
Conducted Power (Watts)	0.1816	0.1782	0.1799	0.1871	0.1897	0.1811
EIRP(dBm)	24.09	24.01	24.05	24.22	24.28	24.08
EIRP(Watts)	0.2564	0.2518	0.2541	0.2642	0.2679	0.2559

LTE Band 41 CA (GT - LC = 1.50 dB) QPSK						
Bandwidth	15M+10M			10M+15M		
Channel PCC	39725	40571	41417	39703	40549	41395
	(Low)	(Mid)	(High)	(Low)	(Mid)	(High)
Channel SCC	39845	40691	41537	39823	40669	41490
	(Low)	(Mid)	(High)	(Low)	(Mid)	(High)
Conducted Power (dBm)	23.15	22.81	22.81	23.30	22.95	22.99
Conducted Power (Watts)	0.2065	0.1910	0.1910	0.2138	0.1972	0.1991
EIRP(dBm)	24.65	24.31	24.31	24.80	24.45	24.49
EIRP(Watts)	0.2917	0.2698	0.2698	0.3020	0.2786	0.2812



LTE Band 41 CA (GT - LC = 1.50 dB) 16QAM									
Bandwidth	15M + 15M			5M + 20M			20M + 5M		
Channel PCC	39725	40545	41365	39683	40528	41373	39750	40595	41440
	(Low)	(Mid)	(High)	(Low)	(Mid)	(High)	(Low)	(Mid)	(High)
Channel SCC	39875	40695	41515	39800	40645	41490	39867	40712	41557
	(Low)	(Mid)	(High)	(Low)	(Mid)	(High)	(Low)	(Mid)	(High)
Conducted Power (dBm)	21.83	21.54	21.15	21.75	22.4	21.34	21.54	21.95	20.72
Conducted Power (Watts)	0.1524	0.1426	0.1303	0.1496	0.1738	0.1361	0.1426	0.1567	0.1180
EIRP(dBm)	23.33	23.04	22.65	23.25	23.90	22.84	23.04	23.45	22.22
EIRP(Watts)	0.2153	0.2014	0.1841	0.2113	0.2455	0.1923	0.2014	0.2213	0.1667

LTE Band 41 CA (GT - LC = 1.50 dB) 16QAM									
Bandwidth	10M + 20M			20M + 10M			15M + 20M		
Channel PCC	39705	40526	41346	39750	40571	41391	39728	40523	41319
	(Low)	(Mid)	(High)	(Low)	(Mid)	(High)	(Low)	(Mid)	(High)
Channel SCC	39849	40670	41490	39894	40715	41535	39899	40694	41490
	(Low)	(Mid)	(High)	(Low)	(Mid)	(High)	(Low)	(Mid)	(High)
Conducted Power (dBm)	21.88	22.05	21.87	21.77	21.84	21.74	21.86	21.6	21.41
Conducted Power (Watts)	0.1542	0.1603	0.1538	0.1503	0.1528	0.1493	0.1535	0.1445	0.1384
EIRP(dBm)	23.38	23.55	23.37	23.27	23.34	23.24	23.36	23.10	22.91
EIRP(Watts)	0.2178	0.2265	0.2173	0.2123	0.2158	0.2109	0.2168	0.2042	0.1954



LTE Band 41 CA (GT - LC = 1.50 dB) 16QAM						
Bandwidth	20M+15M			20M+20M		
Channel PCC	39750	40546	41341	39750	40521	41292
	(Low)	(Mid)	(High)	(Low)	(Mid)	(High)
Channel SCC	39921	40717	41512	39948	40719	41490
	(Low)	(Mid)	(High)	(Low)	(Mid)	(High)
Conducted Power (dBm)	21.80	21.4	21.18	22.07	21.66	21.38
Conducted Power (Watts)	0.1514	0.1380	0.1312	0.1611	0.1466	0.1374
EIRP(dBm)	23.30	22.90	22.68	23.57	23.16	22.88
EIRP(Watts)	0.2138	0.1950	0.1854	0.2275	0.2070	0.1941

LTE Band 41 CA (GT - LC = 1.50 dB) 16QAM						
Bandwidth	15M+10M			10M+15M		
Channel PCC	39725	40571	41417	39703	40549	41395
	(Low)	(Mid)	(High)	(Low)	(Mid)	(High)
Channel SCC	39845	40691	41537	39823	40669	41490
	(Low)	(Mid)	(High)	(Low)	(Mid)	(High)
Conducted Power (dBm)	23.25	22.3	21.04	22.00	22.48	21.25
Conducted Power (Watts)	0.2113	0.1698	0.1271	0.1585	0.1770	0.1334
EIRP(dBm)	24.75	23.80	22.54	23.50	23.98	22.75
EIRP(Watts)	0.2985	0.2399	0.1795	0.2239	0.2500	0.1884



LTE Band 41 CA (GT - LC = 1.50 dB) 64QAM									
Bandwidth	15M + 15M			5M + 20M			20M + 5M		
Channel PCC	39725	40545	41365	39683	40528	41373	39750	40595	41440
	(Low)	(Mid)	(High)	(Low)	(Mid)	(High)	(Low)	(Mid)	(High)
Channel SCC	39875	40695	41515	39800	40645	41490	39867	40712	41557
	(Low)	(Mid)	(High)	(Low)	(Mid)	(High)	(Low)	(Mid)	(High)
Conducted Power (dBm)	20.37	19.93	20.23	20.27	20.15	20.94	20.01	20.04	19.88
Conducted Power (Watts)	0.1089	0.0984	0.1054	0.1064	0.1035	0.1242	0.1002	0.1009	0.0973
EIRP(dBm)	21.87	21.43	21.73	21.77	21.65	22.44	21.51	21.54	21.38
EIRP(Watts)	0.1538	0.1390	0.1489	0.1503	0.1462	0.1754	0.1416	0.1426	0.1374

LTE Band 41 CA (GT - LC = 1.50 dB) 64QAM									
Bandwidth	10M + 20M			20M + 10M			15M + 20M		
Channel PCC	39705	40526	41346	39750	40571	41391	39728	40523	41319
	(Low)	(Mid)	(High)	(Low)	(Mid)	(High)	(Low)	(Mid)	(High)
Channel SCC	39849	40670	41490	39894	40715	41535	39899	40694	41490
	(Low)	(Mid)	(High)	(Low)	(Mid)	(High)	(Low)	(Mid)	(High)
Conducted Power (dBm)	20.31	19.98	20.12	20.26	19.84	19.88	20.20	20.07	20.16
Conducted Power (Watts)	0.1074	0.0995	0.1028	0.1062	0.0964	0.0973	0.1047	0.1016	0.1038
EIRP(dBm)	21.81	21.48	21.62	21.76	21.34	21.38	21.70	21.57	21.66
EIRP(Watts)	0.1517	0.1406	0.1452	0.1500	0.1361	0.1374	0.1479	0.1435	0.1466



LTE Band 41 CA (GT - LC = 1.50 dB) 64QAM						
Bandwidth	20M+15M			20M+20M		
Channel PCC	39750	40546	41341	39750	40521	41292
	(Low)	(Mid)	(High)	(Low)	(Mid)	(High)
Channel SCC	39921	40717	41512	39948	40719	41490
	(Low)	(Mid)	(High)	(Low)	(Mid)	(High)
Conducted Power (dBm)	19.85	21.36	21.25	20.37	20.41	20.25
Conducted Power (Watts)	0.0966	0.1368	0.1334	0.1089	0.1099	0.1059
EIRP(dBm)	21.35	22.86	22.75	21.87	21.91	21.75
EIRP(Watts)	0.1365	0.1932	0.1884	0.1538	0.1552	0.1496

LTE Band 41 CA (GT - LC = 1.50 dB) 64QAM						
Bandwidth	15M+10M			10M+15M		
Channel PCC	39725	40571	41417	39703	40549	41395
	(Low)	(Mid)	(High)	(Low)	(Mid)	(High)
Channel SCC	39845	40691	41537	39823	40669	41490
	(Low)	(Mid)	(High)	(Low)	(Mid)	(High)
Conducted Power (dBm)	21.53	21.33	20.83	20.88	22.38	20.88
Conducted Power (Watts)	0.1422	0.1358	0.1211	0.1225	0.1730	0.1225
EIRP(dBm)	23.03	22.83	22.33	22.38	23.88	22.38
EIRP(Watts)	0.2009	0.1919	0.1710	0.1730	0.2443	0.1730



Peak-to-Average Ratio

Mode	LTE Band 13 / 10MHz				
Mod.	QPSK		16QAM		Limit: 13dB
RB Size	1RB	Full RB	1RB	Full RB	Result
Lowest CH	-	-	-	-	PASS
Middle CH	3.62	5.10	4.61	6.06	
Highest CH	-	-	-	-	
Mod.	64QAM		Limit: 13dB		
RB Size	1RB	Full RB	Result		
Lowest CH			PASS		
Middle CH	5.33	6.52			
Highest CH					



LTE Band 13 / 10MHz / QPSK

Middle Channel/ 1RB

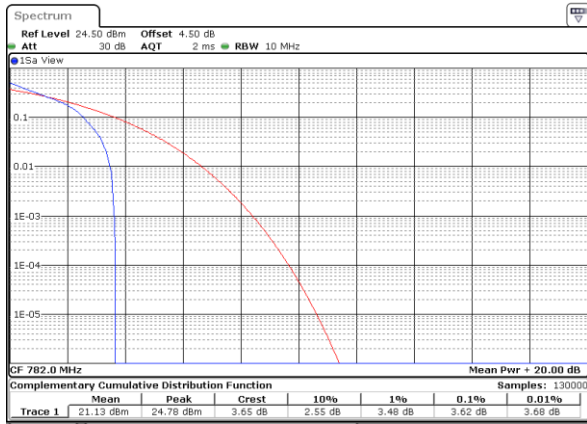

Date: 5 MAR 2019 10:58:03

Middle Channel / Full RB

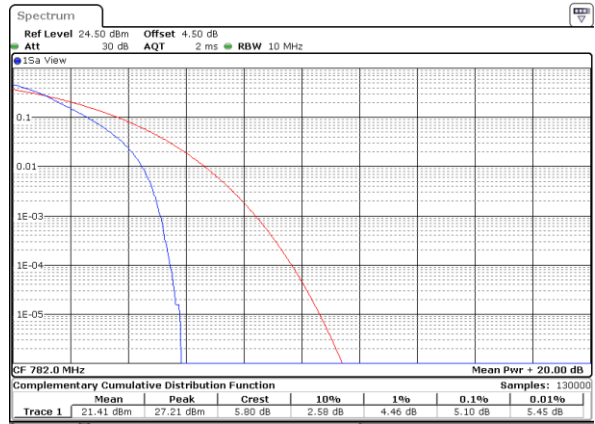

Date: 5 MAR 2019 10:59:25

LTE Band 13 / 10MHz / 16QAM

Middle Channel/ 1RB



Date: 5 MAR 2019 10:58:34

Middle Channel / Full RB

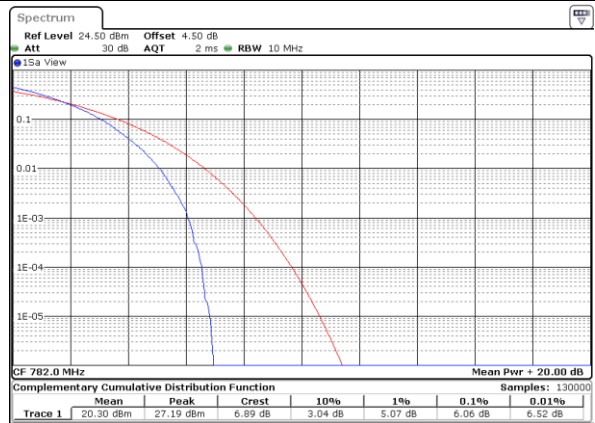

Date: 5 MAR 2019 10:59:46

LTE Band 13 / 10MHz / 64QAM

Middle Channel/ 1RB

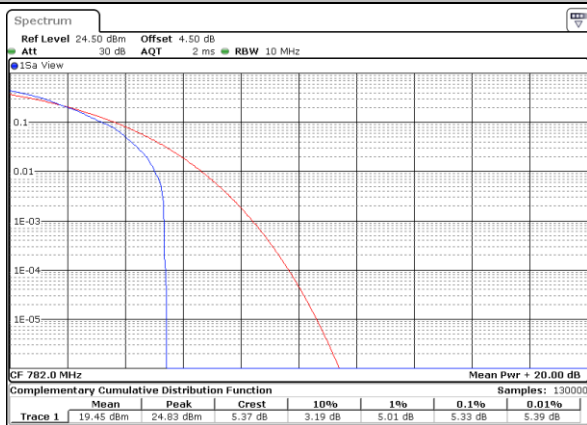

Date: 5 MAR 2019 10:58:53

Middle Channel / Full RB

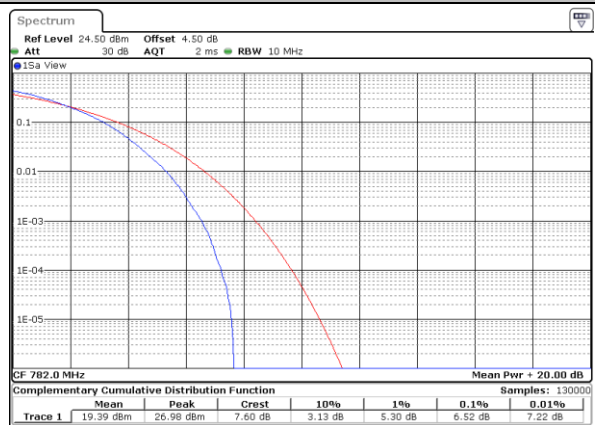

Date: 5 MAR 2019 11:00:08



26dB Bandwidth

Mode	LTE Band 13 : 26dB BW(MHz)										
	5MHz		10MHz		5MHz	10MHz					
BW	QPSK	16QAM	QPSK	16QAM	64QAM	64QAM					
Mod.	QPSK	16QAM	QPSK	16QAM	64QAM	64QAM					
Lowest CH	4.905	4.935			4.935						
Middle CH	4.895	4.935	9.95	9.81	4.905	10.03					
Highest CH	4.945	4.905			4.925						



For CA

Mode	LTE Band 41 : 26dB BW(MHz)				
QPSK					
BW	5MHz+20MHz	10MHz+15MHz	10MHz+20MHz	15MHz+10MHz	15MHz+15MHz
Lowest CH	24.725	24.975	29.79	25.075	30.509
Middle CH	24.675	25.125	29.85	25.175	30.509
Highest CH	24.675	24.875	29.79	25.275	30.569
BW	15MHz+20MHz	20MHz+5MHz	20MHz+10MHz	20MHz+15MHz	20MHz+20MHz
Lowest CH	34.755	24.825	30.09	34.825	39.64
Middle CH	34.825	25.025	29.97	34.685	39.72
Highest CH	34.685	24.875	29.97	34.755	39.72

Mode	LTE Band 41 : 26dB BW(MHz)				
16QAM					
BW	5MHz+20MHz	10MHz+15MHz	10MHz+20MHz	15MHz+10MHz	15MHz+15MHz
Lowest CH	24.775	25.025	29.85	25.025	30.629
Middle CH	24.725	25.075	29.67	24.975	30.569
Highest CH	24.775	24.975	29.97	25.175	30.45
BW	15MHz+20MHz	20MHz+5MHz	20MHz+10MHz	20MHz+15MHz	20MHz+20MHz
Lowest CH	34.755	25.075	29.97	34.895	39.56
Middle CH	34.755	24.925	30.03	34.755	39.72
Highest CH	34.965	24.775	29.97	34.755	39.72

Mode	LTE Band 41 : 26dB BW(MHz)				
64QAM					
BW	5MHz+20MHz	10MHz+15MHz	10MHz+20MHz	15MHz+10MHz	15MHz+15MHz
Lowest CH	24.775	24.925	29.67	25.125	30.509
Middle CH	24.625	24.875	29.91	25.075	30.509
Highest CH	24.476	24.925	29.91	25.075	30.569
BW	15MHz+20MHz	20MHz+5MHz	20MHz+10MHz	20MHz+15MHz	20MHz+20MHz
Lowest CH	34.825	24.875	30.09	34.825	39.80
Middle CH	34.825	24.775	31.109	34.685	39.72
Highest CH	34.895	24.875	29.85	34.685	39.72



LTE Band 13

Lowest Channel / 5MHz / QPSK

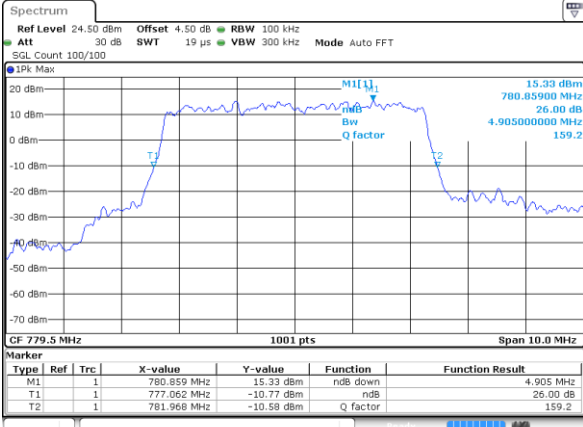

Date: 5 MAR 2019 10:11:42

Lowest Channel / 5MHz / 16QAM

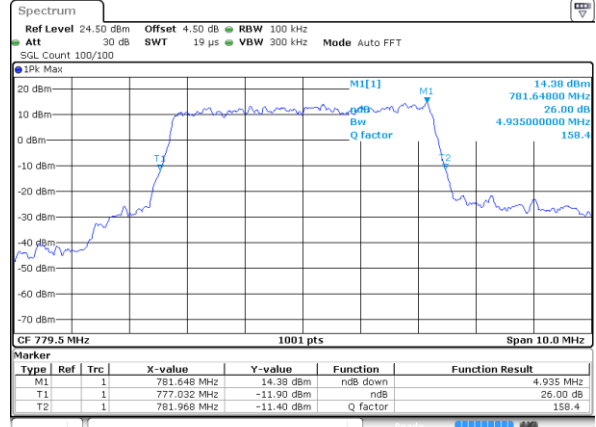

Date: 5 MAR 2019 10:12:10

Middle Channel / 5MHz / QPSK

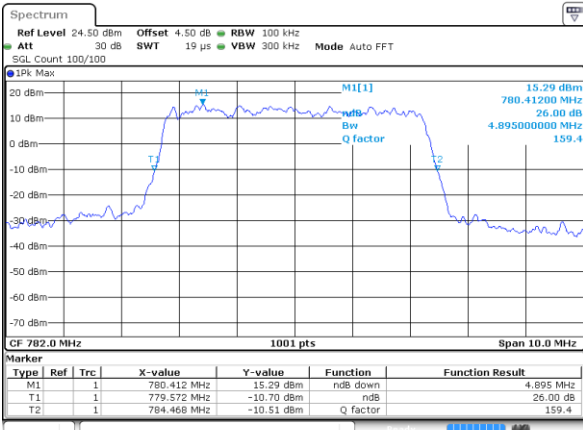

Date: 5 MAR 2019 10:13:54

Middle Channel / 5MHz / 16QAM

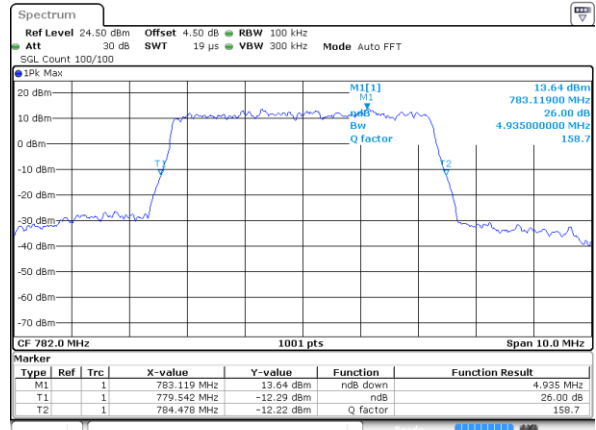

Date: 5 MAR 2019 10:14:20

Highest Channel / 5MHz / QPSK

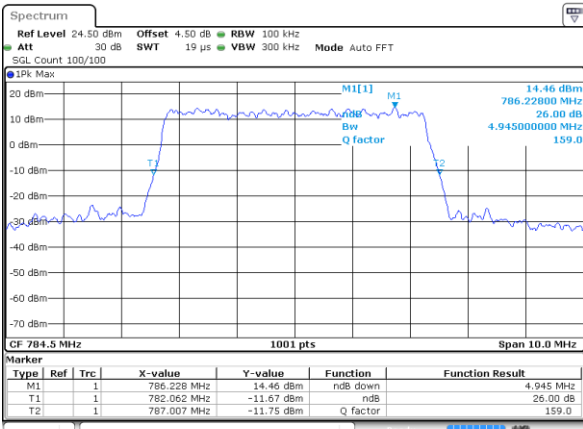

Date: 5 MAR 2019 10:15:16

Highest Channel / 5MHz / 16QAM

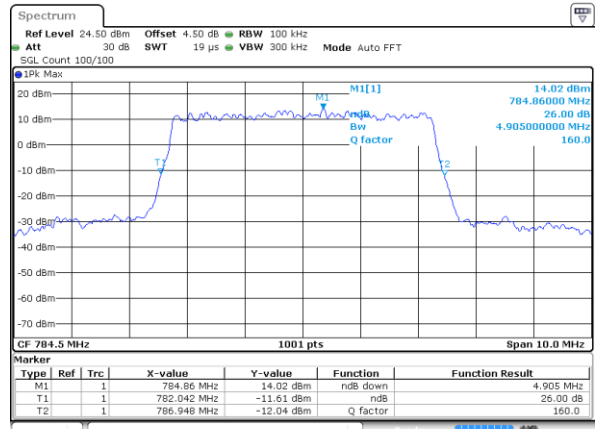

Date: 5 MAR 2019 10:15:44



LTE Band 13

Middle Channel / 10MHz / QPSK

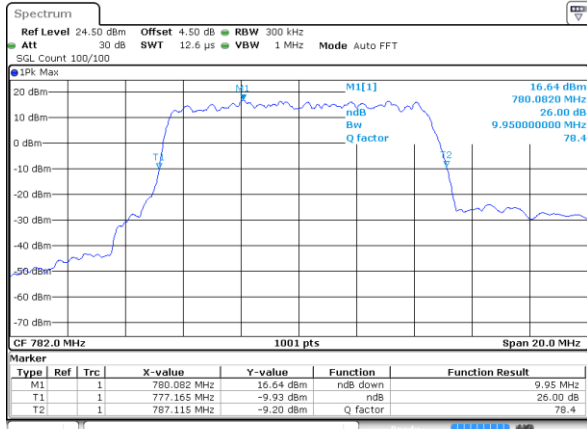

Date: 5 MAR 2019 10:17:09

Middle Channel / 10MHz / 16QAM

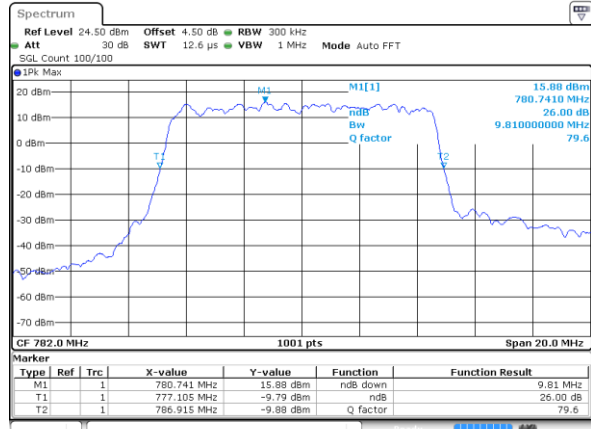

Date: 5 MAR 2019 10:17:35

LTE Band 13

Lowest Channel / 5MHz / 64QAM

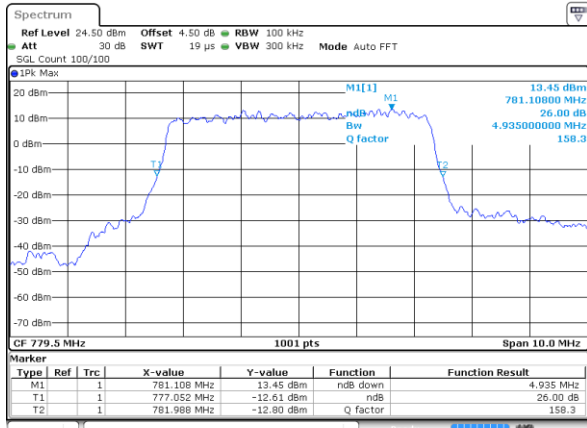

Date: 5 MAR 2019 10:12:36

Middle Channel / 5MHz / 64QAM

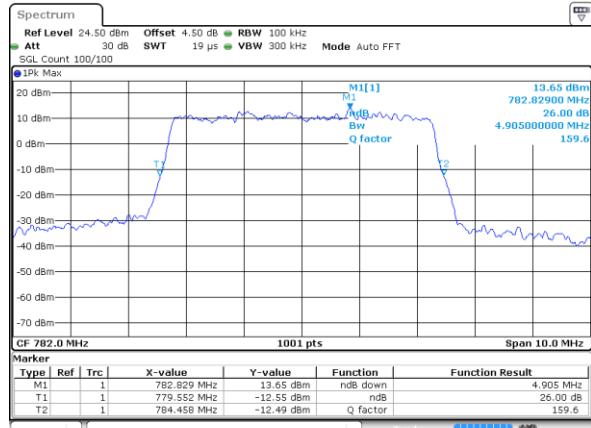

Date: 5 MAR 2019 10:14:45

Highest Channel / 5MHz / 64QAM

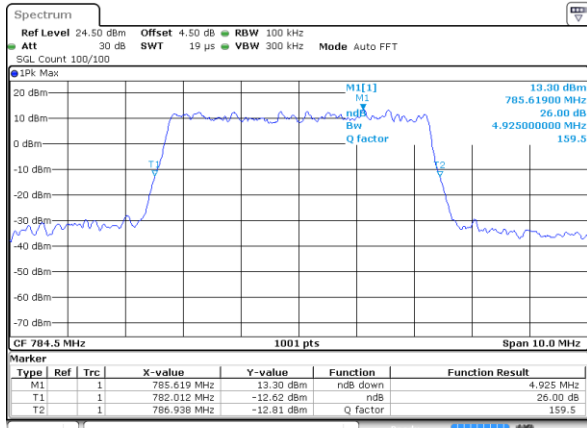

Date: 5 MAR 2019 10:16:07

Middle Channel / 10MHz / 64QAM

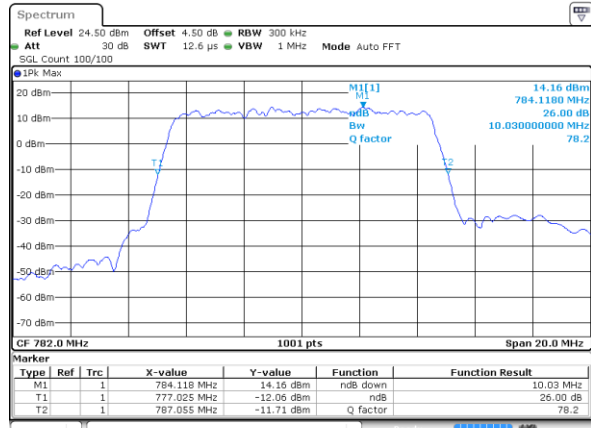

Date: 5 MAR 2019 10:18:01



For CA

LTE Band 41

QPSK

Lowest Channel / 5MHz+20MHz



Date: 22 MAR 2019 21:59:36

Lowest Channel / 10MHz+15MHz



Date: 23 MAR 2019 01:52:27

Middle Channel / 5MHz+20MHz

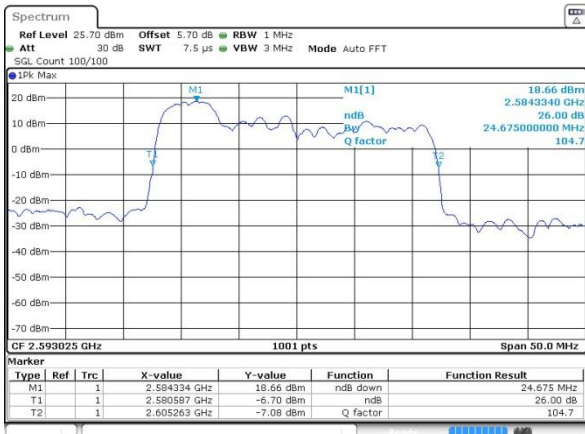

Date: 22 MAR 2019 21:54:16

Middle Channel / 10MHz+15MHz

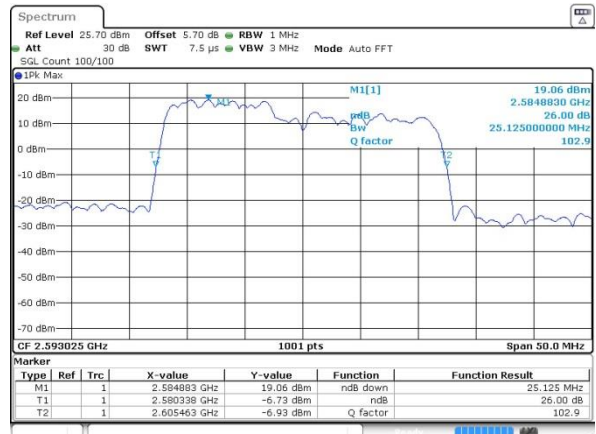

Date: 23 MAR 2019 02:18:21

Highest Channel / 5MHz+20MHz

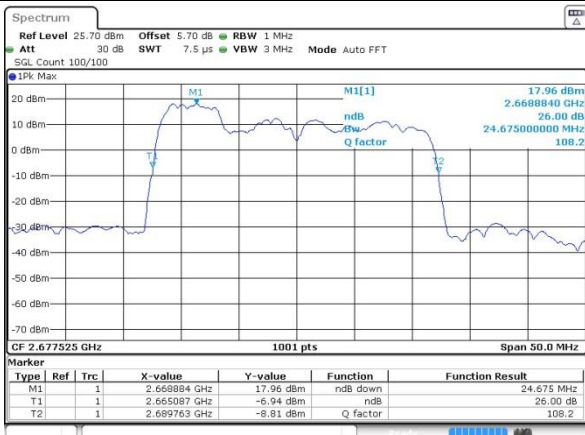

Date: 22 MAR 2019 22:01:47

Highest Channel / 10MHz+15MHz

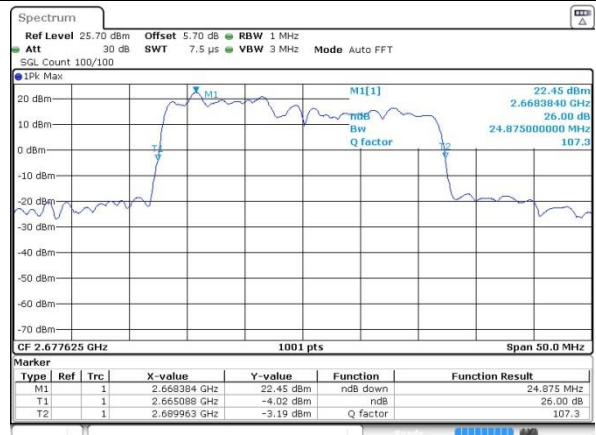

Date: 23 MAR 2019 02:18:58



LTE Band 41

QPSK

Lowest Channel / 10MHz+20MHz

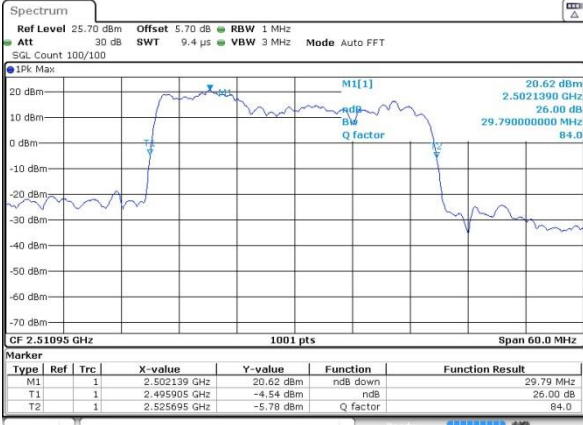

Date: 22 MAR 2019 23:28:19

Lowest Channel / 15MHz+10MHz

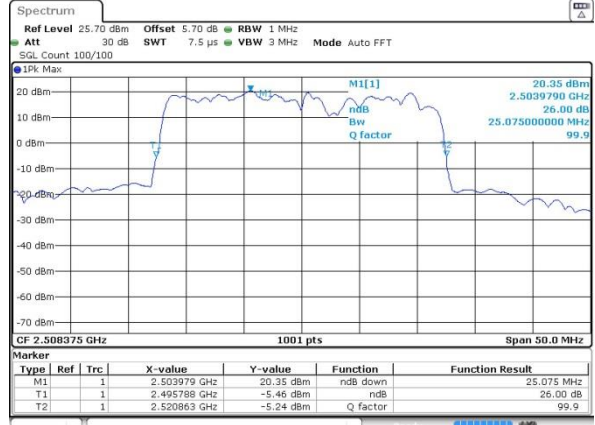

Date: 22 MAR 2019 23:01:44

Middle Channel / 10MHz+20MHz

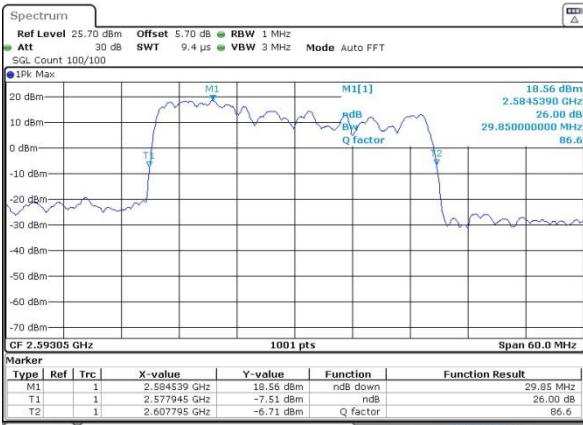

Date: 22 MAR 2019 23:30:23

Middle Channel / 15MHz+10MHz

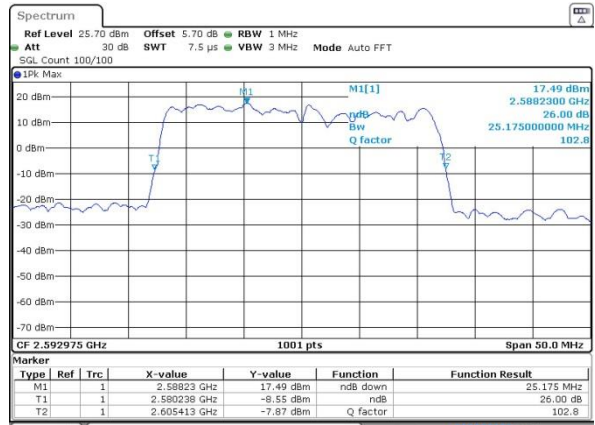

Date: 22 MAR 2019 23:04:10

Highest Channel / 10MHz+20MHz

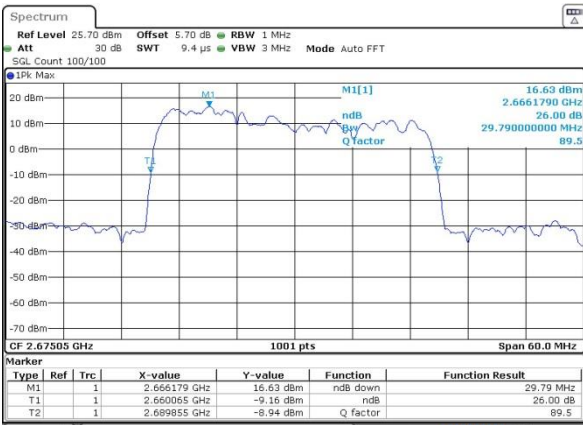

Date: 22 MAR 2019 23:41:20

Highest Channel / 15MHz+10MHz

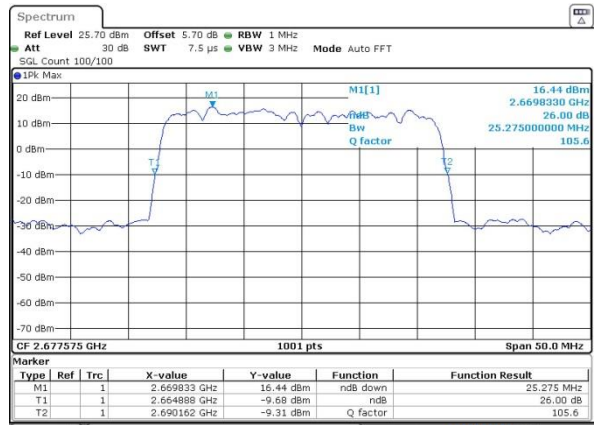

Date: 22 MAR 2019 23:06:38



LTE Band 41

QPSK

Lowest Channel / 15MHz+15MHz

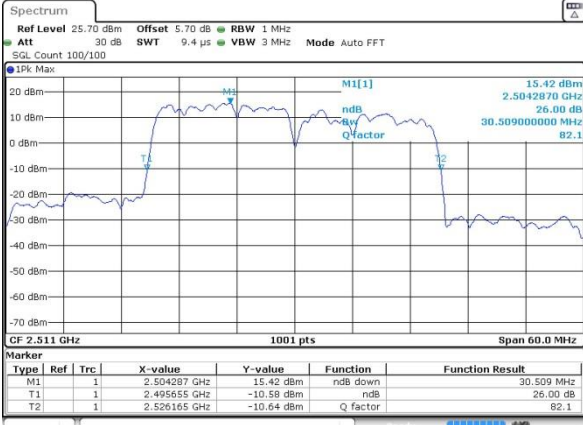

Date: 23.MAR.2019 00:24:42

Lowest Channel / 15MHz+20MHz

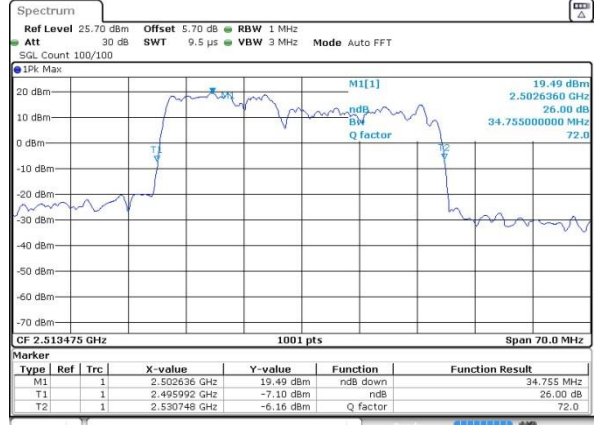

Date: 23.MAR.2019 00:39:22

Middle Channel / 15MHz+15MHz

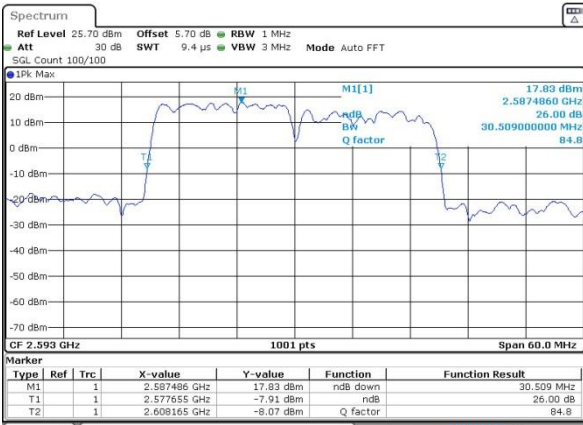

Date: 23.MAR.2019 00:25:40

Middle Channel / 15MHz+20MHz

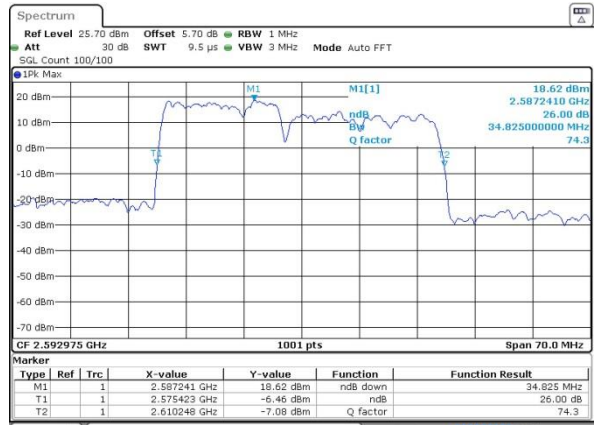

Date: 23.MAR.2019 00:52:29

Highest Channel / 15MHz+15MHz

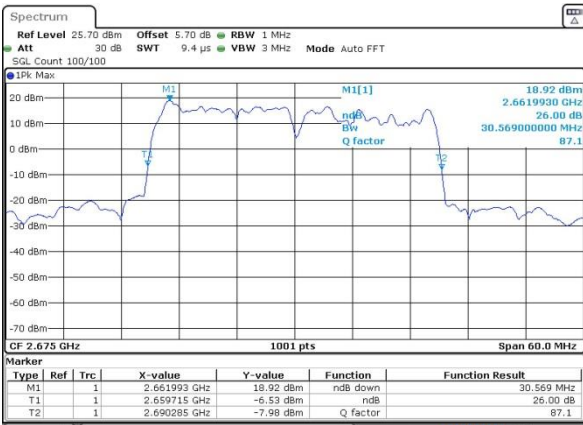

Date: 23.MAR.2019 00:37:47

Highest Channel / 15MHz+20MHz

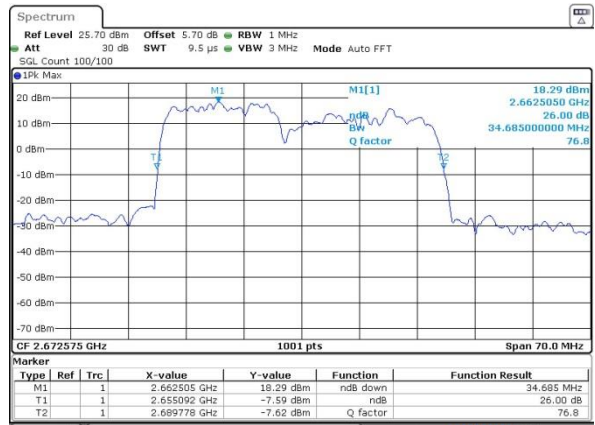

Date: 23.MAR.2019 00:53:14



LTE Band 41

QPSK

Lowest Channel / 20MHz+5MHz

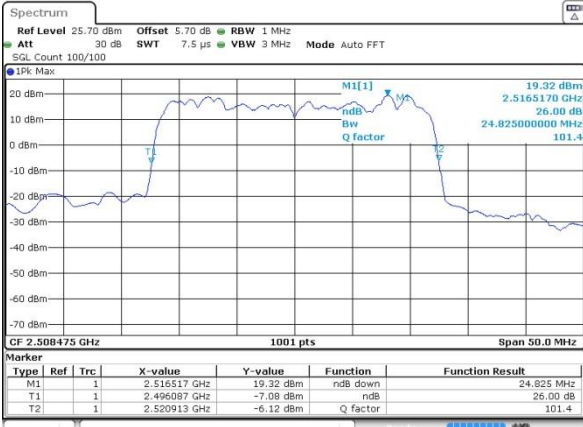

Date: 22 MAR 2019 22:19:13

Lowest Channel / 20MHz+10MHz

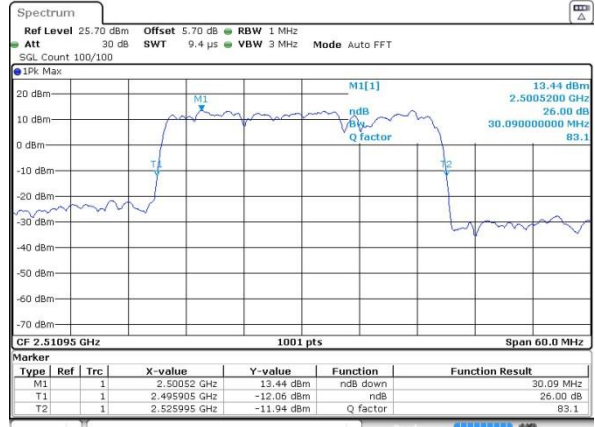

Date: 22 MAR 2019 23:54:18

Middle Channel / 20MHz+5MHz

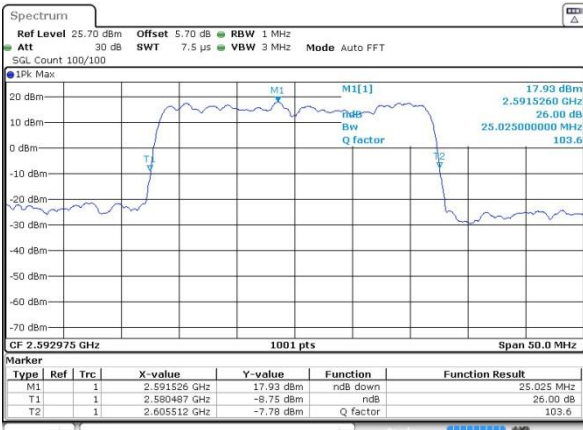

Date: 22 MAR 2019 22:20:37

Middle Channel / 20MHz+10MHz

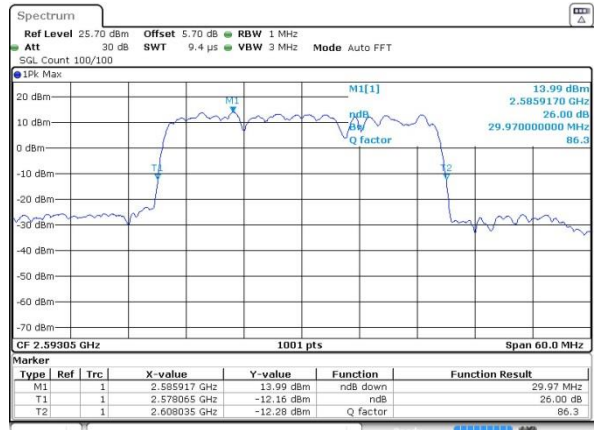

Date: 22 MAR 2019 23:55:51

Highest Channel / 20MHz+5MHz

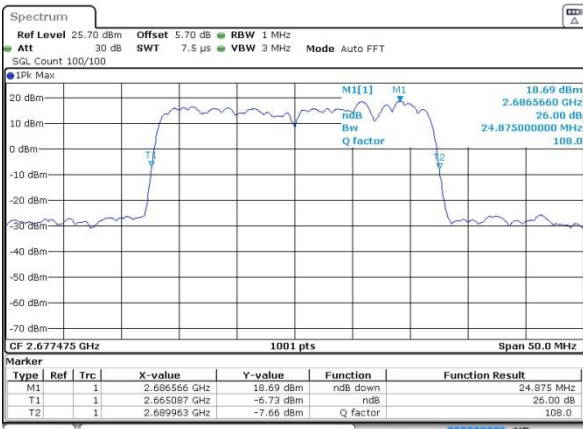

Date: 22 MAR 2019 22:34:29

Highest Channel / 20MHz+10MHz

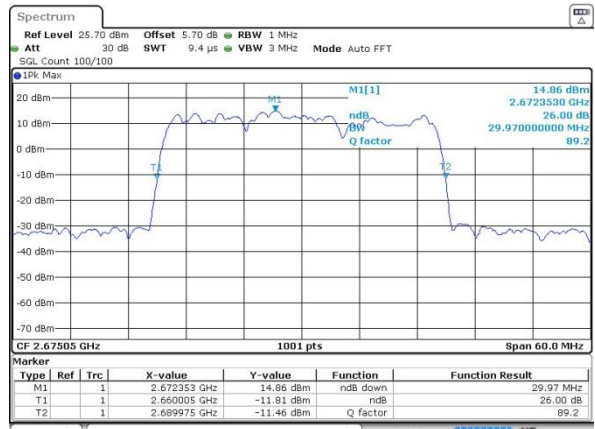

Date: 23 MAR 2019 00:09:42



LTE Band 41

QPSK

Lowest Channel / 20MHz+15MHz

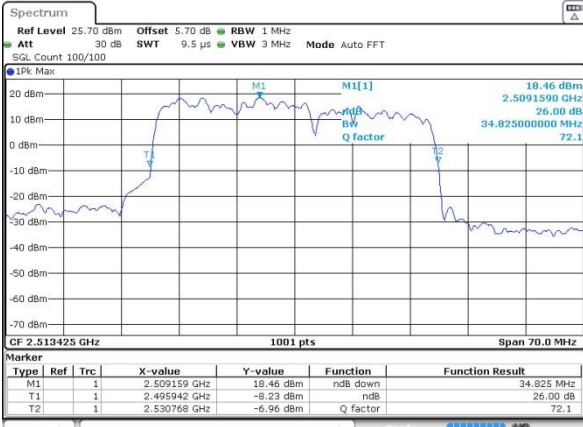

Date: 23.MAR.2019 01:08:25

Lowest Channel / 20MHz+20MHz

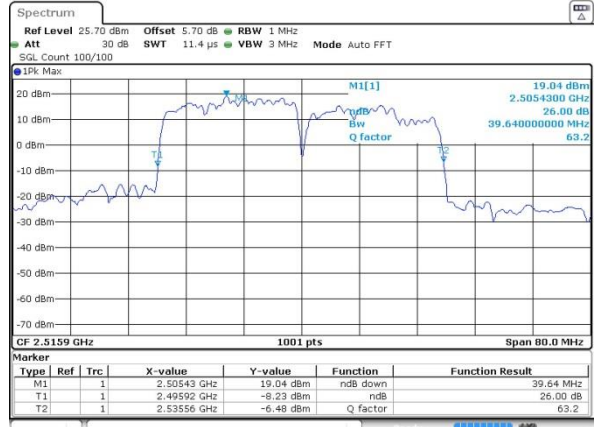

Date: 23.MAR.2019 01:28:18

Middle Channel / 20MHz+15MHz

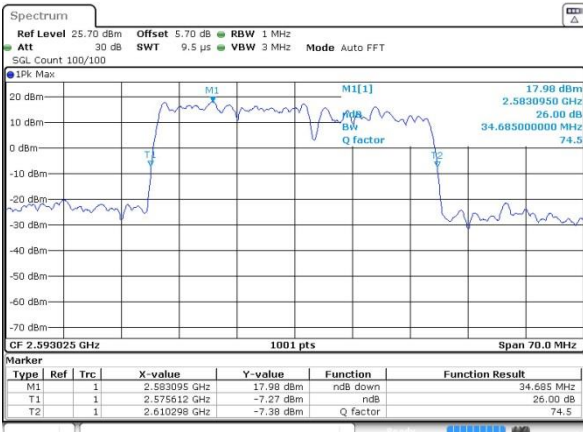

Date: 23.MAR.2019 01:09:31

Middle Channel / 20MHz+20MHz

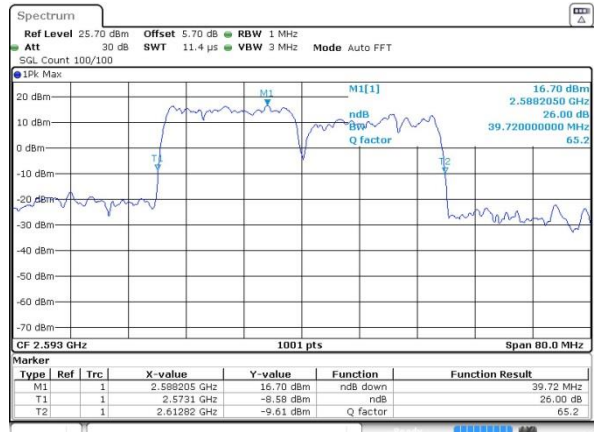

Date: 23.MAR.2019 01:39:29

Highest Channel / 20MHz+15MHz

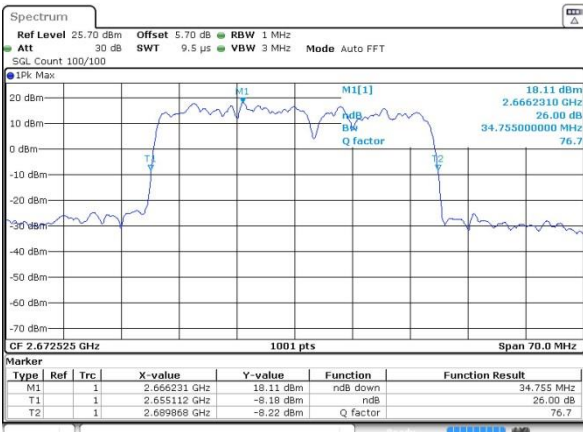

Date: 23.MAR.2019 01:24:08

Highest Channel / 20MHz+20MHz

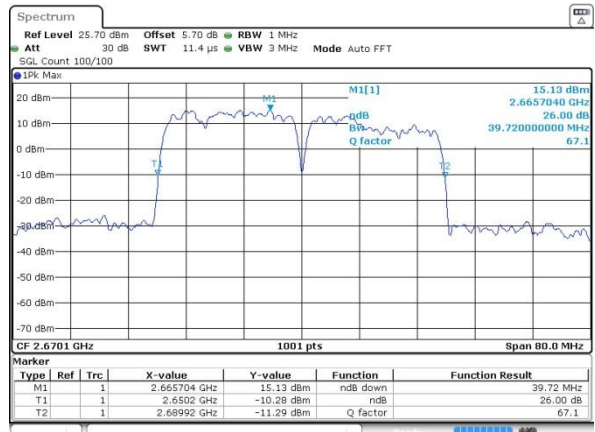

Date: 23.MAR.2019 01:41:51



LTE Band 41

16QAM

Lowest Channel / 5MHz+20MHz

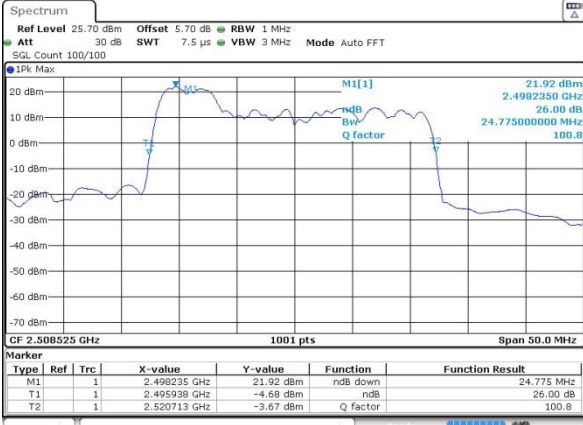

Date: 22 MAR 2019 22:00:00

Lowest Channel / 10MHz+15MHz

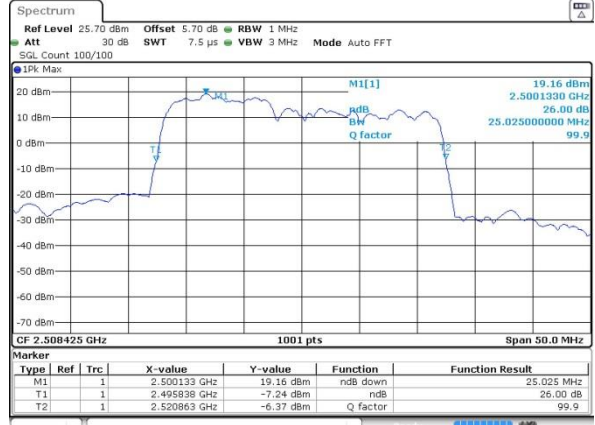

Date: 23 MAR 2019 01:52:50

Middle Channel / 5MHz+20MHz

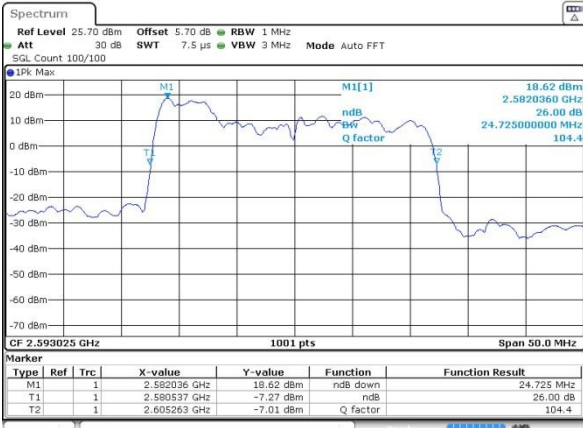

Date: 22 MAR 2019 21:53:44

Middle Channel / 10MHz+15MHz

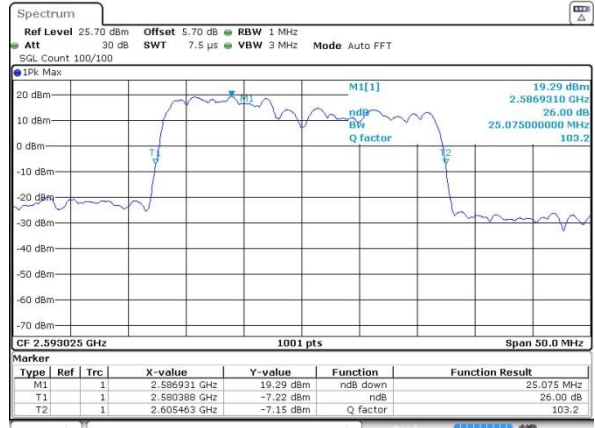

Date: 23 MAR 2019 02:17:47

Highest Channel / 5MHz+20MHz

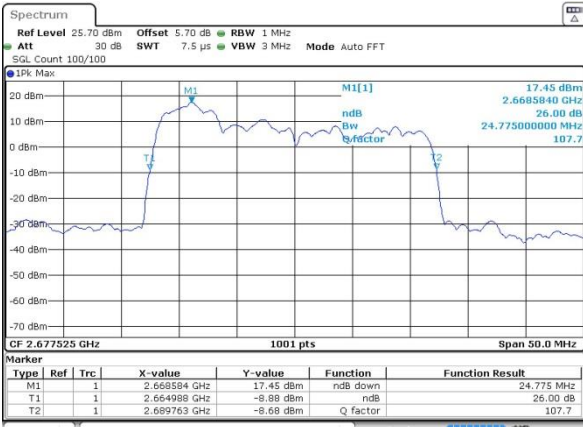

Date: 22 MAR 2019 22:02:11

Highest Channel / 10MHz+15MHz

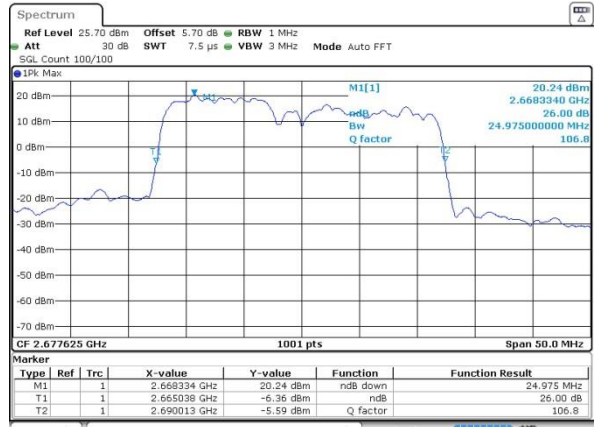

Date: 23 MAR 2019 02:19:23



LTE Band 41

16QAM

Lowest Channel / 10MHz+20MHz

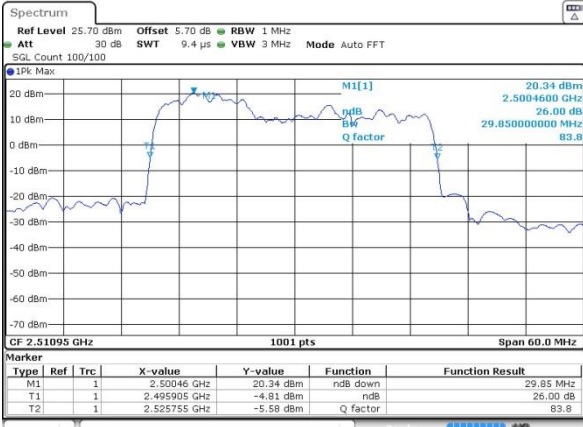

Date: 22 MAR 2019 23:28:42

Lowest Channel / 15MHz+10MHz

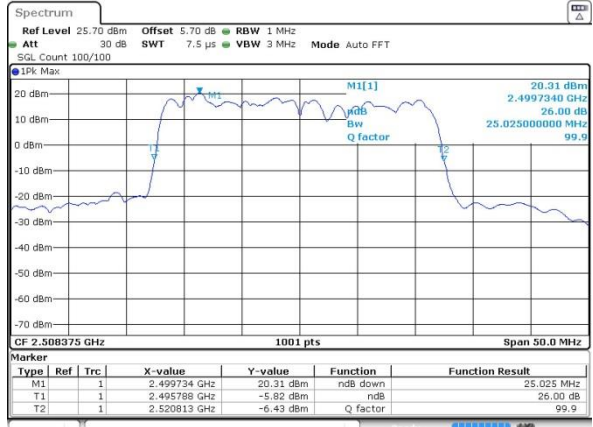

Date: 22 MAR 2019 23:02:09

Middle Channel / 10MHz+20MHz

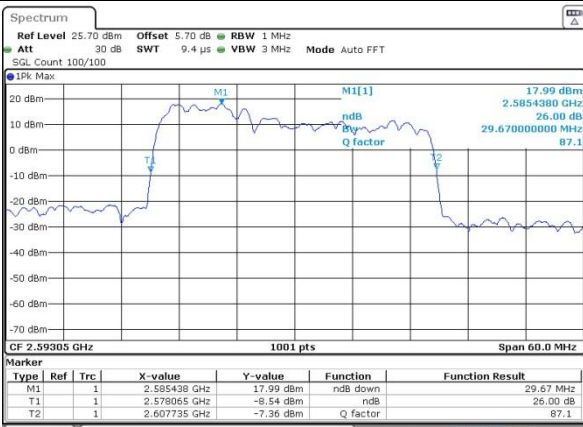

Date: 22 MAR 2019 23:29:43

Middle Channel / 15MHz+10MHz

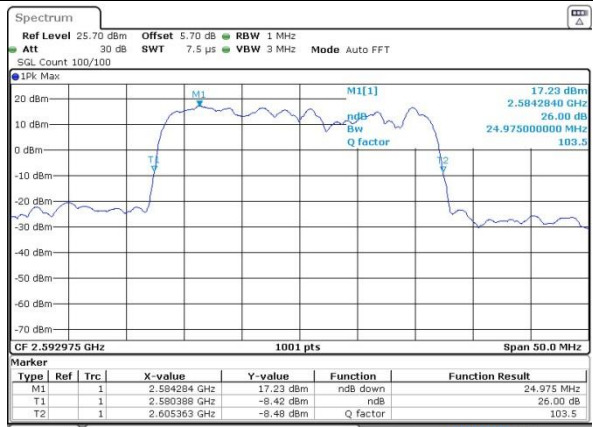

Date: 22 MAR 2019 23:04:35

Highest Channel / 10MHz+20MHz

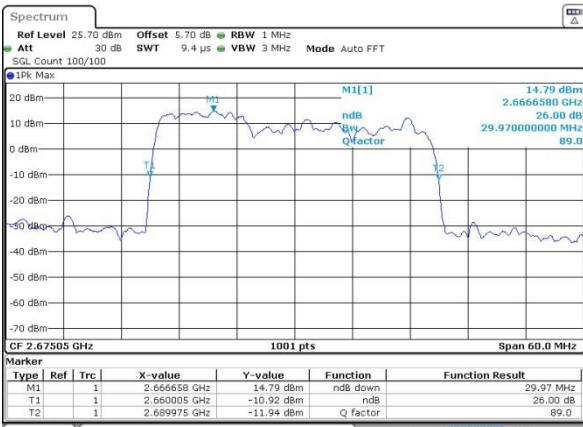

Date: 22 MAR 2019 23:41:44

Highest Channel / 15MHz+10MHz

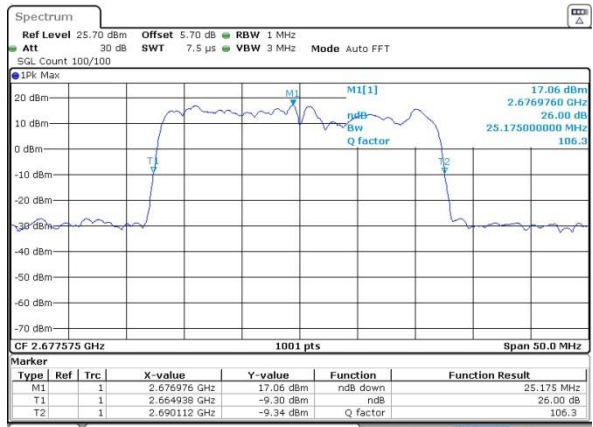

Date: 22 MAR 2019 23:06:12



LTE Band 41

16QAM

Lowest Channel / 15MHz+15MHz

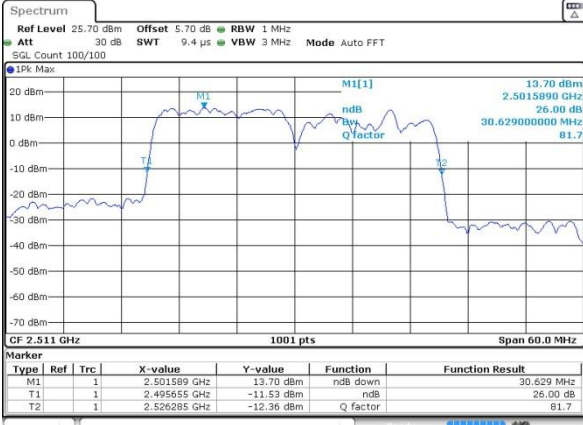

Date: 23 MAR 2019 00:24:06

Lowest Channel / 15MHz+20MHz

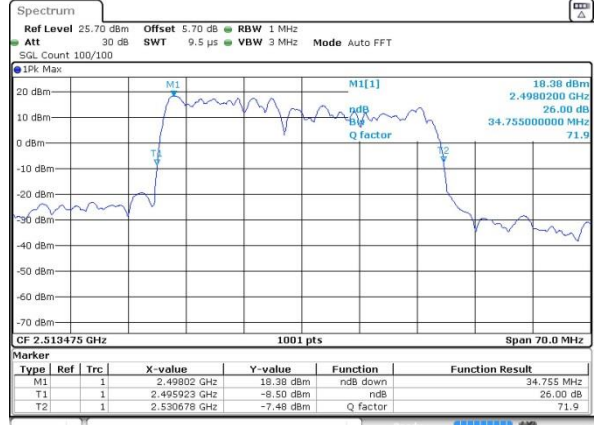

Date: 23 MAR 2019 00:39:47

Middle Channel / 15MHz+15MHz

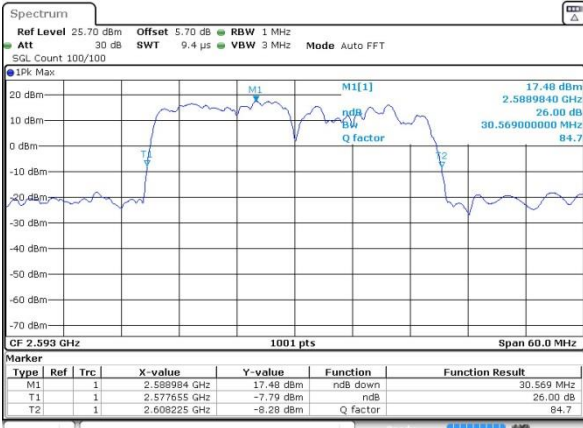

Date: 23 MAR 2019 00:26:14

Middle Channel / 15MHz+20MHz

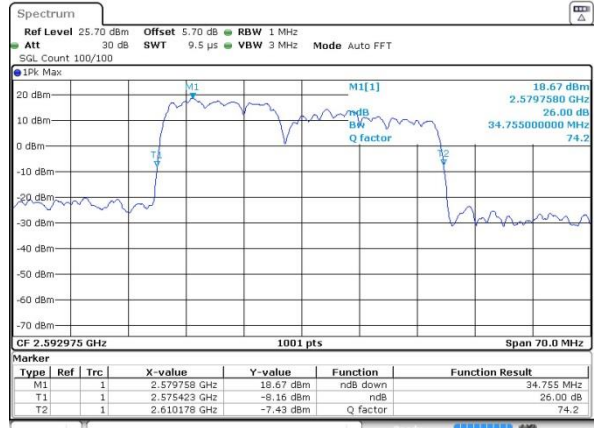

Date: 23 MAR 2019 00:52:04

Highest Channel / 15MHz+15MHz

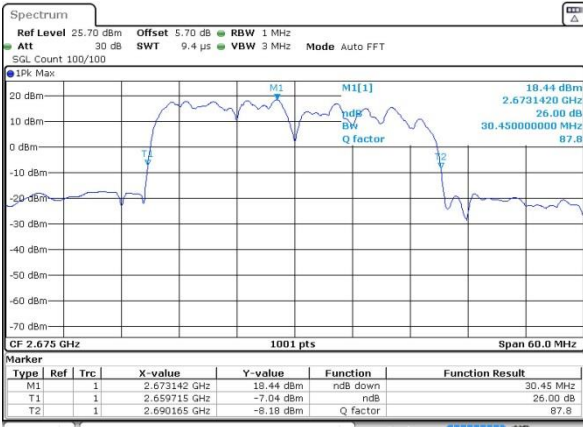

Date: 23 MAR 2019 00:37:18

Highest Channel / 15MHz+20MHz

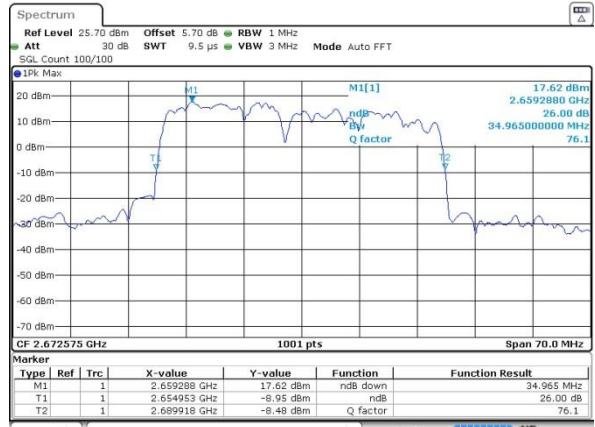

Date: 23 MAR 2019 00:53:36



LTE Band 41

16QAM

Lowest Channel / 20MHz+5MHz

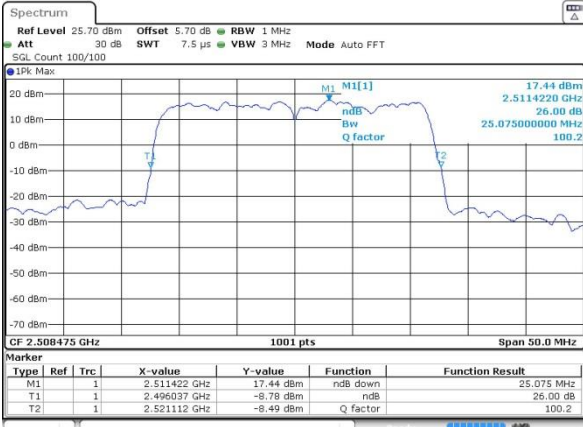

Date: 22 MAR 2019 22:18:42

Lowest Channel / 20MHz+10MHz

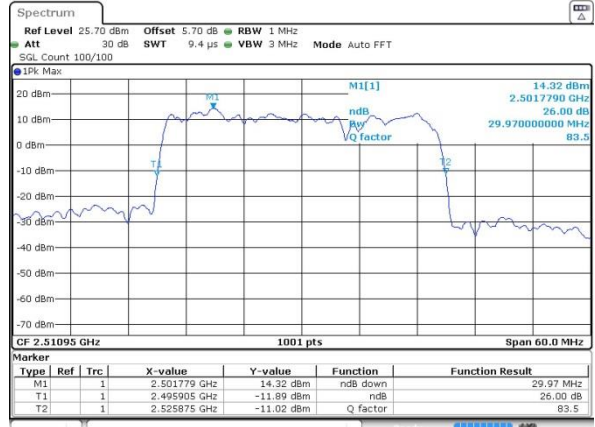

Date: 22 MAR 2019 23:53:57

Middle Channel / 20MHz+5MHz

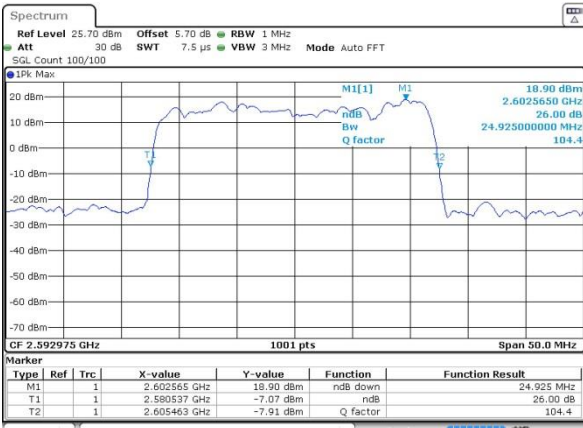

Date: 22 MAR 2019 22:21:19

Middle Channel / 20MHz+10MHz

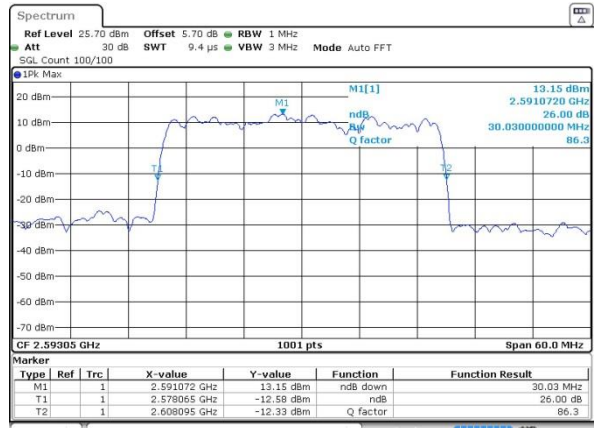

Date: 22 MAR 2019 23:56:17

Highest Channel / 20MHz+5MHz

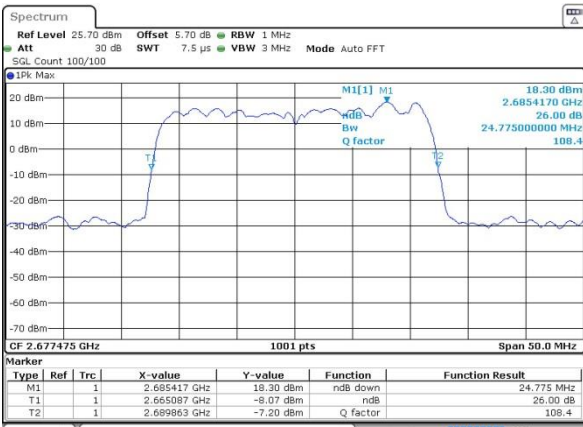

Date: 22 MAR 2019 22:34:04

Highest Channel / 20MHz+10MHz

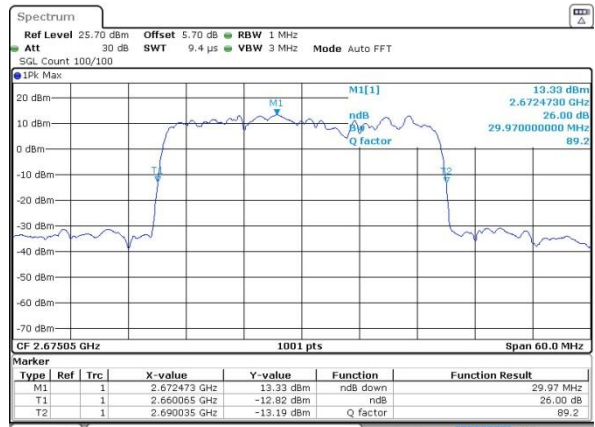

Date: 23 MAR 2019 00:09:11



LTE Band 41

16QAM

Lowest Channel / 20MHz+15MHz

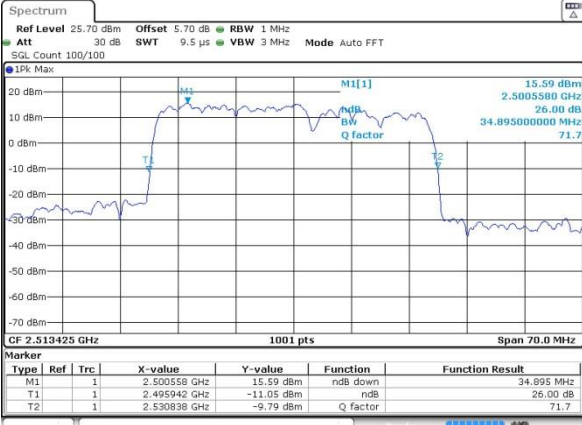

Date: 23 MAR 2019 01:07:55

Lowest Channel / 20MHz+20MHz

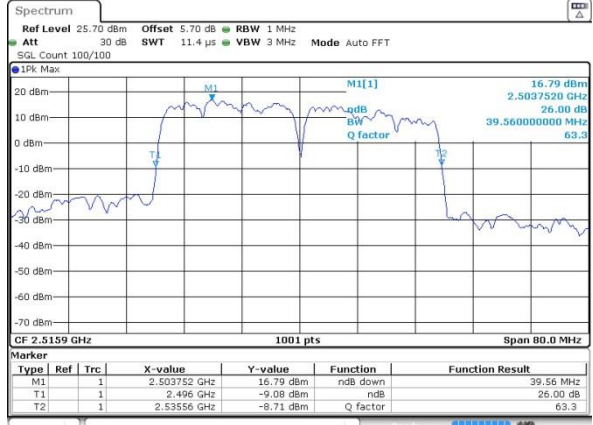

Date: 23 MAR 2019 01:28:48

Middle Channel / 20MHz+15MHz

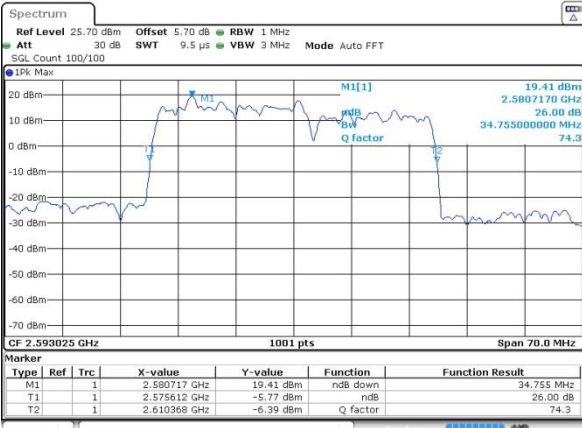

Date: 23 MAR 2019 01:09:57

Middle Channel / 20MHz+20MHz

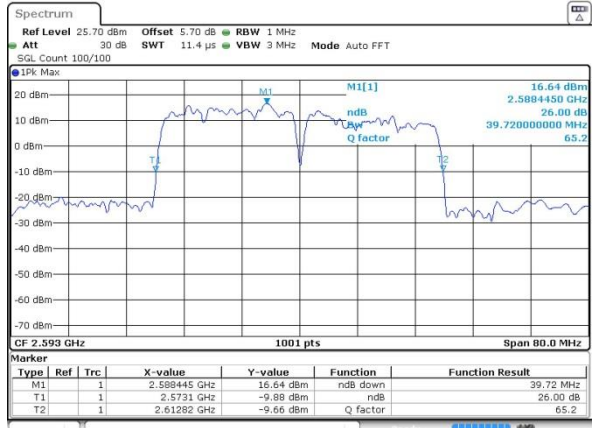

Date: 23 MAR 2019 01:39:54

Highest Channel / 20MHz+15MHz

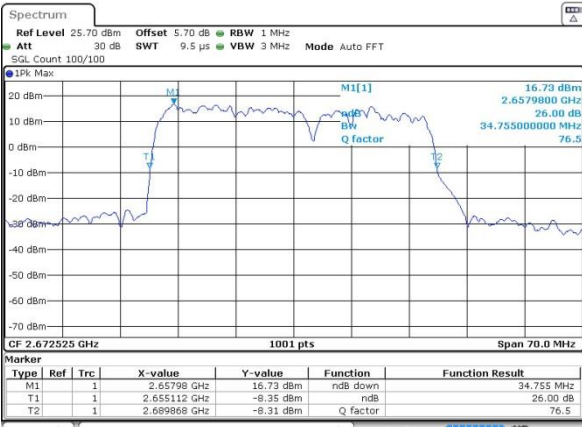

Date: 23 MAR 2019 01:23:45

Highest Channel / 20MHz+20MHz

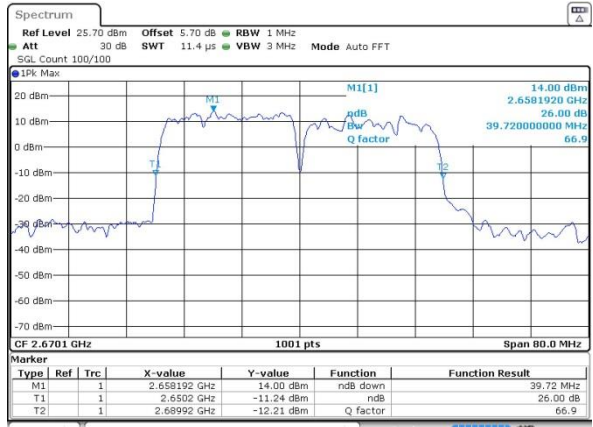

Date: 23 MAR 2019 01:41:27



LTE Band 41

64QAM

Lowest Channel / 5MHz+20MHz

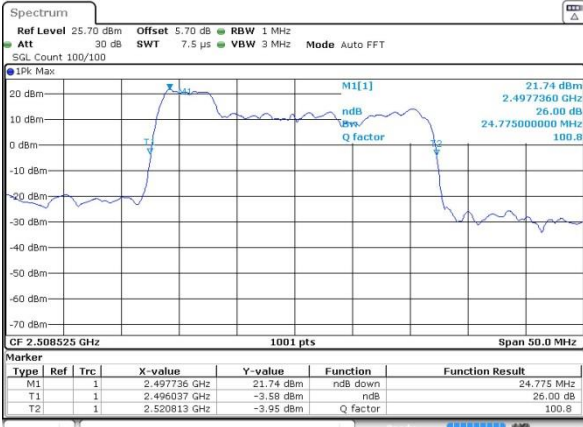

Date: 22 MAR 2019 22:00:33

Lowest Channel / 10MHz+15MHz

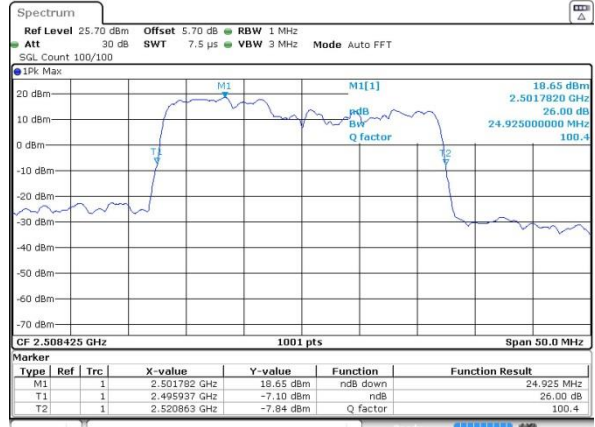

Date: 23 MAR 2019 01:53:15

Middle Channel / 5MHz+20MHz

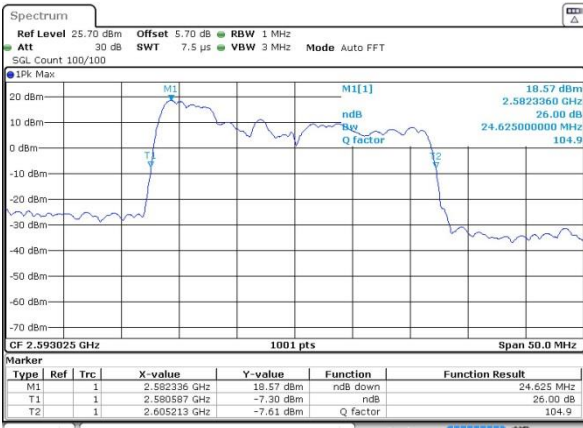

Date: 22 MAR 2019 21:53:17

Middle Channel / 10MHz+15MHz

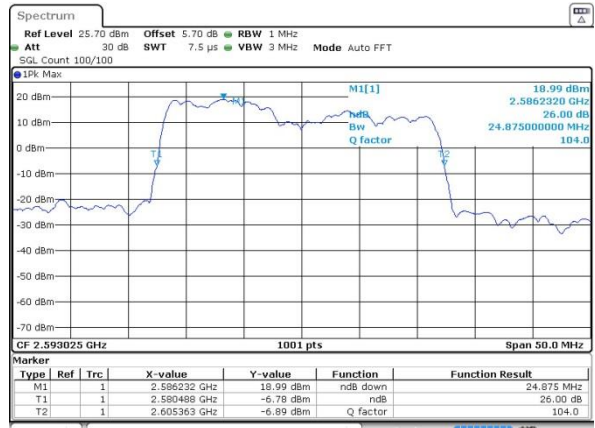

Date: 23 MAR 2019 02:17:27

Highest Channel / 5MHz+20MHz

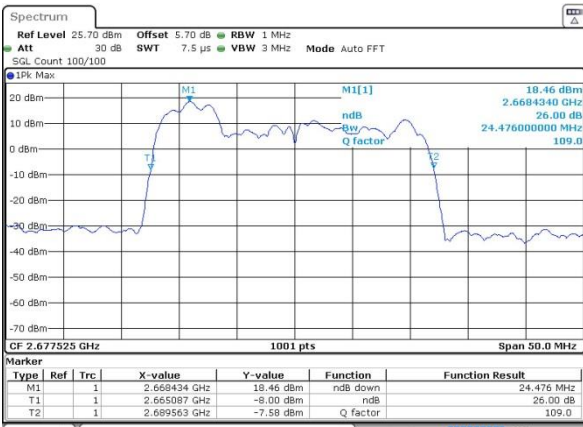

Date: 22 MAR 2019 22:02:38

Highest Channel / 10MHz+15MHz

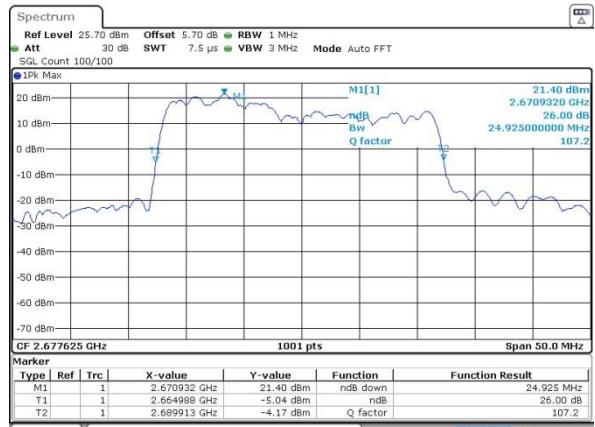

Date: 23 MAR 2019 02:19:48