



# FCC RF Test Report

**APPLICANT** : Motorola Mobility LLC  
**EQUIPMENT** : Mobile Cellular Phone  
**BRAND NAME** : Motorola  
**FCC ID** : IHDT56XE1  
**STANDARD** : FCC Part 15 Subpart C §15.225  
**CLASSIFICATION** : (DXX) Low Power Communication Device Transmitter

This is a variant report. The product was received on Mar. 07, 2018 and testing was completed on Apr. 03, 2018. We, SPORTON INTERNATIONAL INC., would like to declare that the tested sample has been evaluated in accordance with the test procedures and has been in compliance with the applicable technical standards.

The test results in this report apply exclusively to the tested model / sample. Without written approval of SPORTON INTERNATIONAL INC., the test report shall not be reproduced except in full.

Reviewed by: Joseph Lin / Supervisor

Approved by: Jones Tsai / Manager



**SPORTON INTERNATIONAL INC.**

**No. 52, Hwa Ya 1<sup>st</sup> Rd., Hwa Ya Technology Park, Kwei-Shan District, Tao Yuan City, Taiwan, R.O.C.**



# TABLE OF CONTENTS

**REVISION HISTORY.....3**

**SUMMARY OF THE TEST RESULT .....4**

**1. GENERAL DESCRIPTION .....5**

    1.1 Applicant..... 5

    1.2 Manufacturer ..... 5

    1.3 Product Feature of Equipment Under Test ..... 5

    1.4 Product Specification of Equipment Under Test ..... 6

    1.5 Modification of EUT ..... 6

    1.6 Testing Location ..... 7

    1.7 Applicable Standards..... 7

**2. TEST CONFIGURATION OF EQUIPMENT UNDER TEST .....8**

    2.1 Descriptions of Test Mode ..... 8

    2.2 Connection Diagram of Test System ..... 9

    2.3 Table for Supporting Units ..... 11

    2.4 EUT Operation Test Setup ..... 11

**3. TEST RESULTS.....12**

    3.1 AC Power Line Conducted Emissions Measurement ..... 12

    3.2 Field Strength of Fundamental Emissions and Mask Measurement..... 14

    3.3 Radiated Emissions Measurement ..... 16

    3.4 Antenna Requirements..... 19

**4. LIST OF MEASURING EQUIPMENT .....20**

**5. UNCERTAINTY OF EVALUATION .....21**

**APPENDIX A. TEST RESULTS OF CONDUCTED EMISSION TEST**

**APPENDIX B. TEST RESULTS OF RADIATED TEST ITEMS**

    B1. Test Result of Field Strength of Fundamental Emissions

    B2. Results of Radiated Emissions (9 kHz~30MHz)

    B3. Results of Radiated Emissions (30MHz~1GHz)





### SUMMARY OF THE TEST RESULT

Applied Standard: 47 CFR FCC Part 15 Subpart C §15.225				
Part	FCC Rule	Description of Test	Result	Remark
3.1	15.207	AC Power Line Conducted Emissions	Complies	Under limit 0.45 dB at 13.560MHz
-	15.215(c)	20dB Spectrum Bandwidth	Complies	-
	-	99% OBW Spectrum Bandwidth	Complies	-
-	15.225(e)	Frequency Stability	Complies	-
3.2	15.225(a)(b)(c)	Field Strength of Fundamental Emissions	Complies	Max level 66.18 dB $\mu$ V/m at 13.560 MHz
3.3	15.225(d) & 15.209	Radiated Spurious Emissions	Complies	Under limit 5.57 dB at 40.800MHz
3.4	15.203	Antenna Requirements	Complies	-



# 1. General Description

## 1.1 Applicant

Motorola Mobility LLC

222 W, Merchandise Mart Plaza, Chicago IL 60654 USA

## 1.2 Manufacturer

Motorola Mobility LLC

222 W, Merchandise Mart Plaza, Chicago IL 60654 USA

## 1.3 Product Feature of Equipment Under Test

Product Feature	
Equipment	Mobile Cellular Phone
Brand Name	Motorola
FCC ID	IHDT56XE1
IMEI Code	IMEI: 351886090018703 (For Conduction) IMEI: 351886090018927 (For Radiation)
EUT supports Radios application	CDMA/EV-DO/GSM/EGPRS/WCDMA/HSPA/LTE/GNSS/NFC WLAN 11b/g/n HT20 WLAN 11a/n HT20/HT40 WLAN 11ac VHT20/VHT40/VHT80 Bluetooth BR/EDR/LE
HW Version	DVT2
EUT Stage	Identical Prototype

**Remark:**

1. The above EUT's information was declared by manufacturer. Please refer to the specifications or user's manual for more detailed description.
2. This is a variant report by adding WPC Back Cover. All the test cases were performed on original report which can be referred to Sporton Report Number FR811821D. Based on the original report, only worst case was verified.

Accessory List	
WPC Cover	Brand Name : Motorola
	Model Name : MD100W



### 1.4 Product Specification of Equipment Under Test

Standards-related Product Specification	
Tx/Rx Frequency Range	13.553 ~ 13.567MHz
Channel Number	1
Antenna Type	Internal Antenna
Type of Modulation	ASK

**Remark:** The above EUT's information was declared by manufacturer. Please refer to the specifications or user's manual for more detailed description.

### 1.5 Modification of EUT

No modifications are made to the EUT during all test items.



## 1.6 Testing Location

Sporton Lab is accredited to ISO 17025 by Taiwan Accreditation Foundation (TAF code : 1190) and the FCC designation No. TW1190 under the FCC 2.948(e) by Mutual Recognition Agreement (MRA) in FCC Test.

<b>Test Site</b>	SPORTON INTERNATIONAL INC.	
<b>Test Site Location</b>	No. 52, Hwa Ya 1 <sup>st</sup> Rd., Hwa Ya Technology Park, Kwei-Shan District, Tao Yuan City, Taiwan, R.O.C. TEL: +886-3-3273456 / FAX: +886-3-3284978	
<b>Test Site No.</b>	<b>Sporton Site No.</b>	
	CO05-HY	03CH07-HY
<b>Test Engineer</b>	Shareef Yu	Stan Hsieh
<b>Temperature</b>	23~25°C	23~24°C
<b>Relative Humidity</b>	53~56%	53~54%

**Note:** The test site complies with ANSI C63.4 2014 requirement.

## 1.7 Applicable Standards

According to the specifications of the manufacturer, the EUT must comply with the requirements of the following standards:

- ♦ FCC Part 15 Subpart C §15.225
- ♦ ANSI C63.10-2013



## 2. Test Configuration of Equipment Under Test

### 2.1 Descriptions of Test Mode

Investigation has been done on all the possible configurations.

The following table is a list of the test modes shown in this test report.

Test Items	
AC Power Line Conducted Emissions	Field Strength of Fundamental Emissions
Radiated Emissions 9kHz~30MHz	Radiated Emissions 30MHz~1GHz

The EUT pre-scanned in four NFC type, A, B, F, V. The worst type (type F) was recorded in this report.

Test Cases	
<b>AC Conducted Emission</b>	Mode 1 : GSM850 Idle + Bluetooth Link + WLAN Link + NFC Tx + WPC Back cover + Battery + LG Charging pad + USB Cable (Charging from Adapter)  Mode 2 : GSM850 Idle + Bluetooth Link + WLAN Link + NFC Tx + WPC Back cover + Battery + PMA Charging pad + Adapter
<b>Remark:</b> The worst case of conducted emission is mode 2; only the test data of it was reported.	

## 2.2 Connection Diagram of Test System

### <AC Conducted Emissions with WPC Charging Mode>

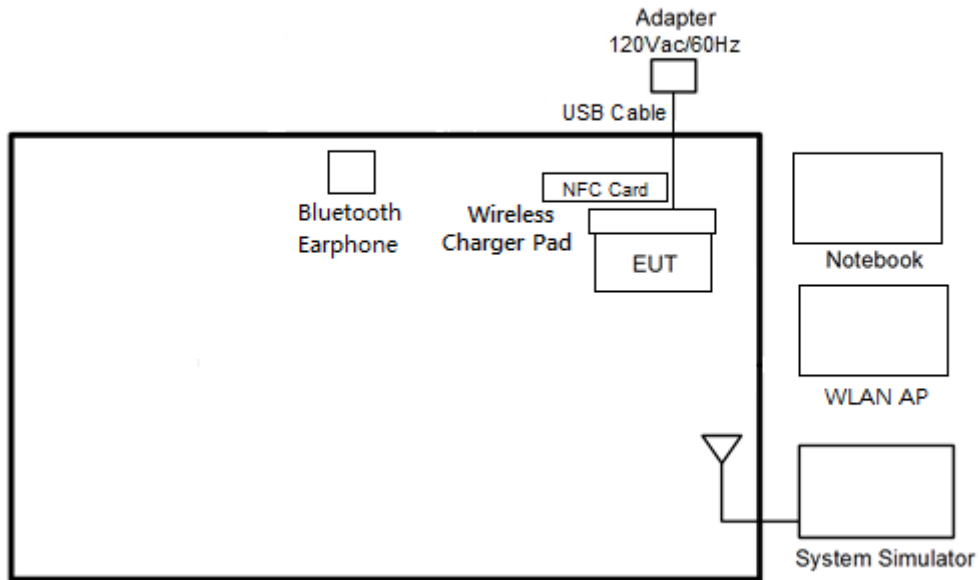

### <AC Conducted Emissions with PAM Charging Mode>

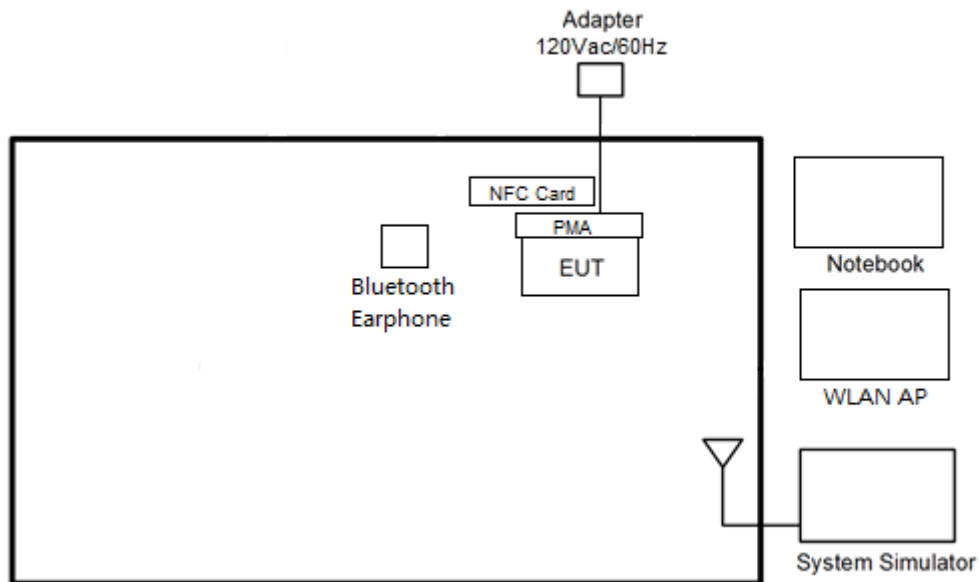

< For Fundamental Emissions and Mask and Radiated Emissions Measurement >

<WPC Charging Mode>

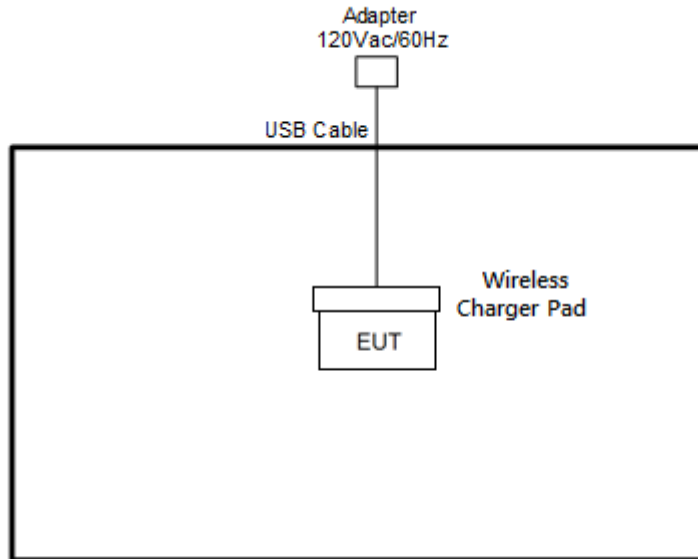

<PMA Charging Mode>

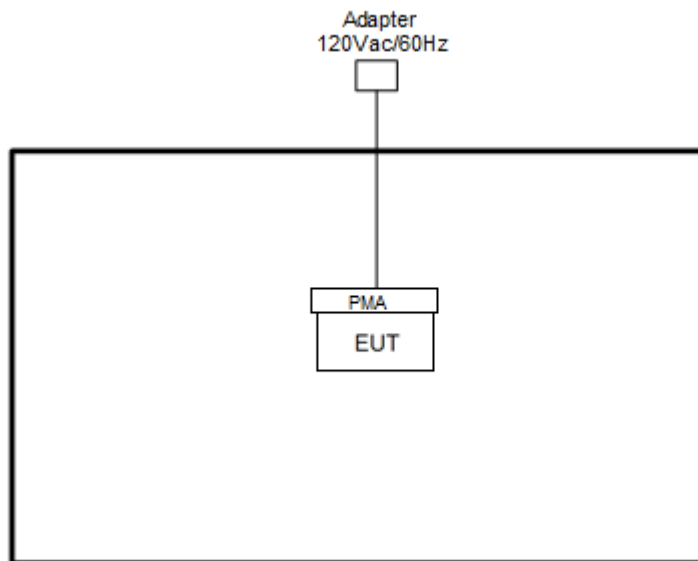



### 2.3 Table for Supporting Units

Item	Equipment	Trade Name	Model Name	FCC ID	Data Cable	Power Cord
1.	System Simulator	Anritsu	MT8820C	N/A	N/A	Unshielded, 1.8 m
2.	WLAN AP	ASUS	RT-AC66U	MSQ-RTAC66U	N/A	Unshielded,1.8m
3.	SD Card	SanDisk	MicroSD HC	FCC DoC	N/A	N/A
4.	Bluetooth Earphone	lenovo	LBH 301	FCC DoC	N/A	N/A
5.	Notebook	DELL	Latitude E6320	FCC DoC/ Contains FCC ID: QDS-BRCM1054	N/A	AC I/P: Unshielded, 1.2 m DC O/P: Shielded, 1.8 m
6.	LG Charging pad	LG	WCD-110	FCC DoC	N/A	N/A
7.	PMA Charging pad	Moto	kinxie	FCC DoC	N/A	N/A
8.	USB Cable	N/A	N/A	N/A	N/A	N/A
9.	Adapter	N/A	N/A	N/A	N/A	N/A
10.	NFC Card	NA	NA	NA	NA	NA

### 2.4 EUT Operation Test Setup

The EUT was programmed to be in continuously transmitting mode.

The ancillary equipment, NFC card, is used to make the EUT (NFC) continuously transmit at 13.56MHz and is placed around 0 cm gap to the EUT.



### 3. Test Results

#### 3.1 AC Power Line Conducted Emissions Measurement

##### 3.1.1 Limit of AC Conducted Emission

For equipment that is designed to be connected to the public utility (AC) power line, the radio frequency voltage that is conducted back onto the AC power line on any frequency or frequencies within the band 150 kHz to 30 MHz shall not exceed the limits in the following table.

Frequency of Emission (MHz)	Conducted Limit (dB $\mu$ V)	
	Quasi-Peak	Average
0.15-0.5	66 to 56*	56 to 46*
0.5-5	56	46
5-30	60	50

\*Decreases with the logarithm of the frequency.

For terminal test result, the testing follows FCC KDB 174176.

##### 3.1.2 Measuring Instruments

See list of measuring instruments of this test report.

##### 3.1.3 Test Procedures

1. The EUT was placed 0.4 meter from the conducting wall of the shielding room, and it was kept at least 80 centimeters from any other grounded conducting surface.
2. Connect EUT to the power mains through a line impedance stabilization network (LISN).
3. All the support units are connecting to the other LISN.
4. The LISN provides 50 ohm coupling impedance for the measuring instrument.
5. The FCC states that a 50 ohm, 50 microhenry LISN should be used.
6. Both sides of AC line were checked for maximum conducted interference.
7. The frequency range from 150 kHz to 30 MHz was searched.
8. Set the test-receiver system to Peak Detect Function and specified bandwidth (IF Bandwidth = 9kHz) with Maximum Hold Mode. Then measurement is also conducted by Average Detector and Quasi-Peak Detector Function respectively.

### 3.1.4 Test setup

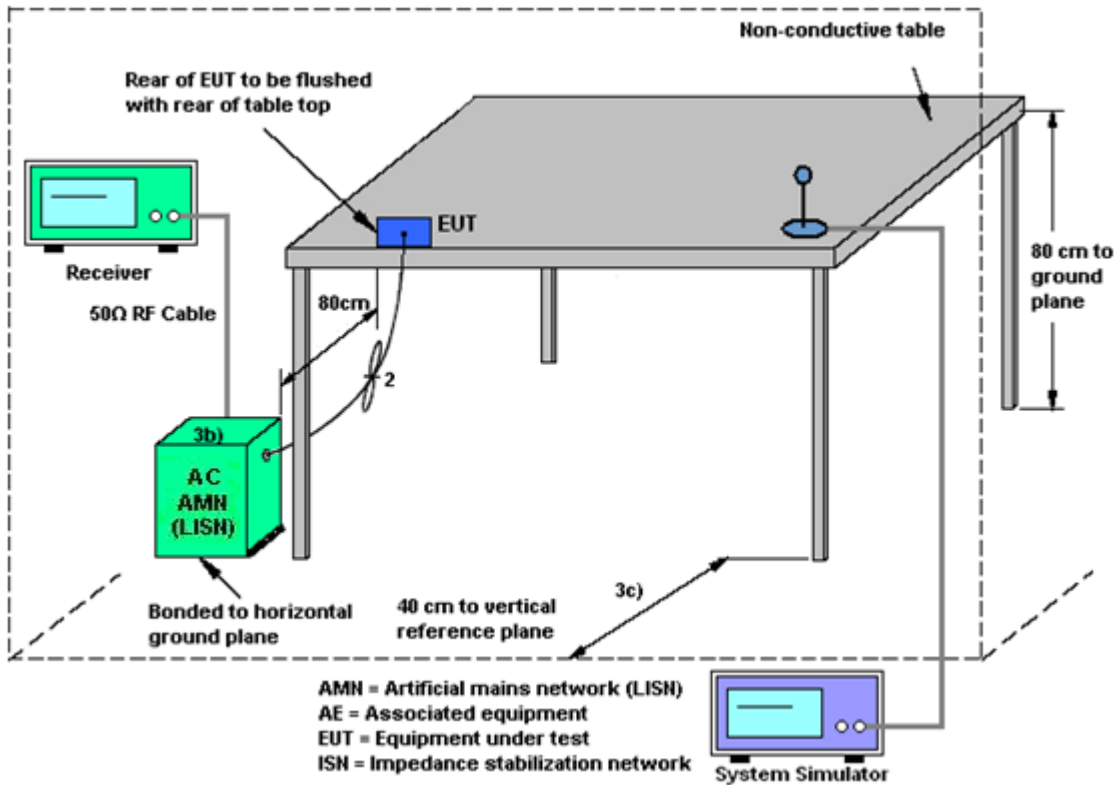

### 3.1.5 Test Result of AC Conducted Emission

Please refer to Appendix A.

**Note:**

(1) with antenna

Remark: 13.56 MHz is the NFC RF fundamental signal.

(2) with dummy load

Remark: Only the fundamental NFC signal needs to be retested per C63.4.



### 3.2 Field Strength of Fundamental Emissions and Mask Measurement

#### 3.2.1 Limit

Rules and specifications	FCC CFR 47 Part 15 section 15.225			
Description	Compliance with the spectrum mask is tested with RBW set to 9kHz.			
Freq. of Emission (MHz)	Field Strength ( $\mu$ V/m) at 30m	Field Strength (dB $\mu$ V/m) at 30m	Field Strength (dB $\mu$ V/m) at 10m	Field Strength (dB $\mu$ V/m) at 3m
1.705~13.110	30	29.5	48.58	69.5
13.110~13.410	106	40.5	59.58	80.5
13.410~13.553	334	50.5	69.58	90.5
13.553~13.567	15848	84.0	103.08	124.0
13.567~13.710	334	50.5	69.58	90.5
13.710~14.010	106	40.5	59.58	80.5
14.010~30.000	30	29.5	48.58	69.5

#### 3.2.2 Measuring Instruments

See list of measuring instruments of this test report.

### 3.2.3 Test Procedures

1. Configure the EUT according to ANSI C63.10. The EUT was placed on the top of the turntable 0.8 meter above ground. The phase center of the loop receiving antenna mounted antenna tower was placed 3 meters far away from the turntable.
2. Power on the EUT and all the supporting units. The turntable was rotated by 360 degrees to determine the position of the highest radiation.
3. The height of the receiving antenna was fixed at one meter above ground to find the maximum emissions field strength.
4. For Fundamental emissions, use the receiver to measure QP reading.
5. When the radiated emissions limits are expressed in terms of the average value of the emissions, and pulsed operation is employed, the measurement field strength shall be determined by averaging over one complete pulse train, including blanking intervals, as long as the pulse train does not exceed 0.1 seconds. As an alternative (provided the transmitter operates for longer than 0.1 seconds) or in cases where the pulse train exceeds 0.1 seconds, the measured field strength shall be determined from the average absolute voltage during a 0.1 second interval during which the field strength is at its maximum value.
6. Compliance with the spectrum mask is tested with RBW set to 9kHz.

Note: Emission level (dB $\mu$ V/m) = 20 log Emission level ( $\mu$ V/m).

### 3.2.4 Test Setup

For radiated emissions below 30MHz

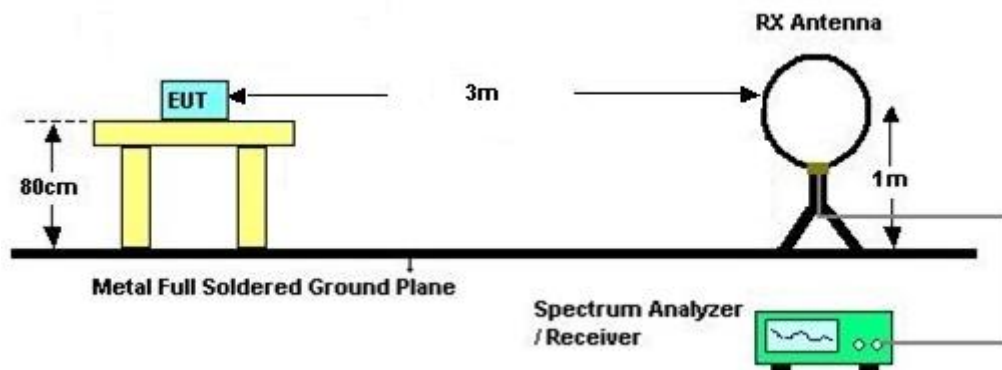

### 3.2.5 Test Result of Field Strength of Fundamental Emissions and Mask

Please refer to Appendix B.



### 3.3 Radiated Emissions Measurement

#### 3.3.1 Limit

The field strength of any emissions which appear outside of 13.110 ~14.010MHz band shall not exceed the general radiated emissions limits.

Frequencies (MHz)	Field Strength (µV/m)	Measurement Distance (meters)
0.009~0.490	2400/F(kHz)	300
0.490~1.705	24000/F(kHz)	30
1.705~30.0	30	30
30~88	100	3
88~216	150	3
216~960	200	3
Above 960	500	3

#### 3.3.2 Measuring Instruments

See list of measuring instruments of this test report.

#### 3.3.3 Measuring Instrument Setting

The following table is the setting of receiver.

Receiver Parameter	Setting
Attenuation	Auto
Frequency Range: 9kHz~150kHz	RBW 200Hz for QP
Frequency Range: 150kHz~30MHz	RBW 9kHz for QP
Frequency Range: 30MHz~1000MHz	RBW 120kHz for Peak

**Note:** The emission limits shown in the above table are based on measurements employing a CISPR quasi-peak detector except for the frequency bands 9-90 kHz, 110-490 kHz. Radiated emission limits in these two bands are based on measurements employing an average detector.



### **3.3.4 Test Procedures**

1. Configure the EUT according to ANSI C63.10. The EUT was placed on the top of the turntable 0.8 meter above ground. The phase center of the receiving antenna mounted on the top of a height-variable antenna tower was placed 3 meters far away from the turntable.
2. Power on the EUT and all the supporting units. The turntable was rotated by 360 degrees to determine the position of the highest radiation.
3. The height of the broadband receiving antenna was varied between one meter and four meters above ground to find the maximum emissions field strength of both horizontal and vertical polarization.
4. For each suspected emissions, the antenna tower was scan (from 1 M to 4 M) and then the turntable was rotated (from 0 degree to 360 degrees) to find the maximum reading.
5. Set the test-receiver system to Peak or CISPR quasi-peak Detect Function with specified bandwidth under Maximum Hold Mode.
6. When the radiated emissions limits are expressed in terms of the average value of the emissions, and pulsed operation is employed, the measurement field strength shall be determined by averaging over one complete pulse train, including blanking intervals, as long as the pulse train does not exceed 0.1 seconds. As an alternative (provided the transmitter operates for longer than 0.1 seconds) or in cases where the pulse train exceeds 0.1 seconds, the measured field strength shall be determined from the average absolute voltage during a 0.1 second interval during which the field strength is at its maximum value.
7. In case the emission is lower than 30MHz, loop antenna has to be used for measurement and the recorded data should be QP measured by receiver. Antenna Requirements

### 3.3.5 Test Setup

For radiated emissions below 30MHz

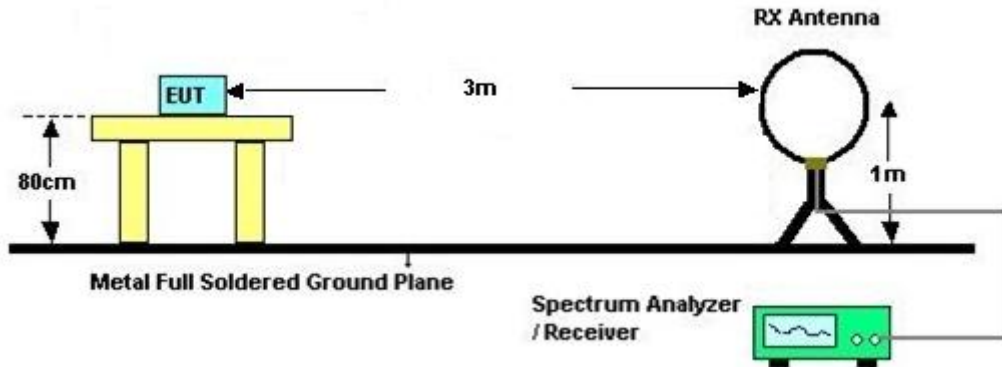

For radiated emissions above 30MHz

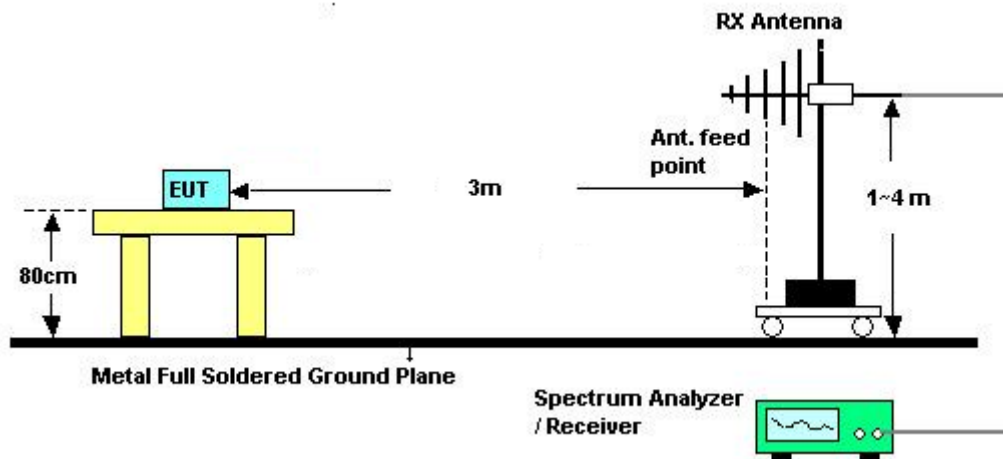

### 3.3.6 Test Result of Radiated Emissions Measurement

Please refer to Appendix B.

**Remark:** There is a comparison data of both open-field test site and semi-Anechoic chamber, and the result came out very similar.



## **3.4 Antenna Requirements**

### **3.4.1 Standard Applicable**

Except for special regulations, the Low-power Radio-frequency Devices must not be equipped with any jacket for installing an antenna with extension cable. An intentional radiator shall be designed to ensure that no antenna other than that furnished by the responsible party shall be used with the device. The use of a permanently attached antenna or of an antenna that uses a unique coupling to the intentional radiator shall be considered sufficient to comply with the provisions of this Section. The manufacturer may design the unit so that the user can replace a broken antenna, but the use of a standard antenna jack or electrical connector is prohibited.

The use of a permanently attached antenna or of an antenna that uses a unique coupling to the intentional radiator shall be considered sufficient to comply with the rule.

### **3.4.2 Antenna Anti-Replacement Construction**

An embedded-in antenna design is used.



### 4. List of Measuring Equipment

Instrument	Manufacturer	Model No.	Serial No.	Characteristics	Calibration Date	Test Date	Due Date	Remark
AC Power Source	ChainTek	APC-1000W	N/A	N/A	N/A	Mar. 20, 2018~ Apr. 03, 2018	N/A	Conduction (CO05-HY)
EMI Test Receiver	Rohde & Schwarz	ESR3	102388	3.6GHz	Dec. 08, 2017	Mar. 20, 2018~ Apr. 03, 2018	Dec. 07, 2018	Conduction (CO05-HY)
LISN	Rohde & Schwarz	ENV216	100080	9kHz~30MHz	Nov. 30, 2017	Mar. 20, 2018~ Apr. 03, 2018	Nov. 29, 2018	Conduction (CO05-HY)
LISN	Rohde & Schwarz	ENV216	100081	9kHz~30MHz	Dec. 08, 2017	Mar. 20, 2018~ Apr. 03, 2018	Dec. 07, 2018	Conduction (CO05-HY)
Software	Rohde & Schwarz	EMC32 V10.30	N/A	N/A	N/A	Mar. 20, 2018~ Apr. 03, 2018	N/A	Conduction (CO05-HY)
Bilog Antenna	TESEQ	CBL 6111D&00800 N1D01N-06	35419&03	30MHz to 1GHz	Dec. 18, 2017	Mar. 23, 2018~ Mar. 24, 2018	Dec. 17, 2018	Radiation (03CH07-HY)
Loop Antenna	Rohde & Schwarz	HFH2-Z2	100315	9 kHz~30 MHz	Nov. 10, 2017	Mar. 23, 2018~ Mar. 24, 2018	Nov. 09, 2018	Radiation (03CH07-HY)
Spectrum Analyzer	Agilent	N9010A	MY534701 18	10Hz~44GHz	Apr. 17, 2017	Mar. 23, 2018~ Mar. 24, 2018	Apr. 16, 2018	Radiation (03CH07-HY)
Antenna Mast	Max-Full	MFA520BS	N/A	1m~4m	N/A	Mar. 23, 2018~ Mar. 24, 2018	N/A	Radiation (03CH07-HY)
Turn Table	ChainTek	Chaintek 3000	N/A	0~360 Degree	N/A	Mar. 23, 2018~ Mar. 24, 2018	N/A	Radiation (03CH07-HY)
Amplifier	SONOMA	310N	187231	9kHz~1GHz	Jan. 08, 2018	Mar. 23, 2018~ Mar. 24, 2018	Jan. 07, 2019	Radiation (03CH07-HY)
EMI Test Receiver	Agilent	N9038A(MXE)	MY532900 53	20Hz to 26.5GHz	Jan. 16, 2018	Mar. 23, 2018~ Mar. 24, 2018	Jan. 15, 2019	Radiation (03CH07-HY)
Software	Audix	E3 6.2009-8-2 4	N/A	N/A	N/A	Mar. 23, 2018~ Mar. 24, 2018	N/A	Radiation (03CH07-HY)



## 5. Uncertainty of Evaluation

### Uncertainty of Conducted Emission Measurement (150 kHz ~ 30 MHz)

Measuring Uncertainty for a Level of Confidence of 95% ( $U = 2Uc(y)$ )	2.70
---	------

### Uncertainty of Radiated Emission Measurement (9 kHz ~ 30 MHz)

Measuring Uncertainty for a Level of Confidence of 95% ( $U = 2Uc(y)$ )	3.40
---	------

### Uncertainty of Radiated Emission Measurement (30 MHz ~ 1000 MHz)

Measuring Uncertainty for a Level of Confidence of 95% ( $U = 2Uc(y)$ )	5.70
---	------



## Appendix A. Test Results of Conducted Emission Test

Test Engineer :	Shareef Yu	Temperature :	23~25°C
		Relative Humidity :	53~56%

## EUT Information

Report NO : 811821-09  
 Test Mode : Mode 2  
 Test Voltage : 120Vac/60Hz  
 Phase : Line  
 Original Mode

Full Spectrum

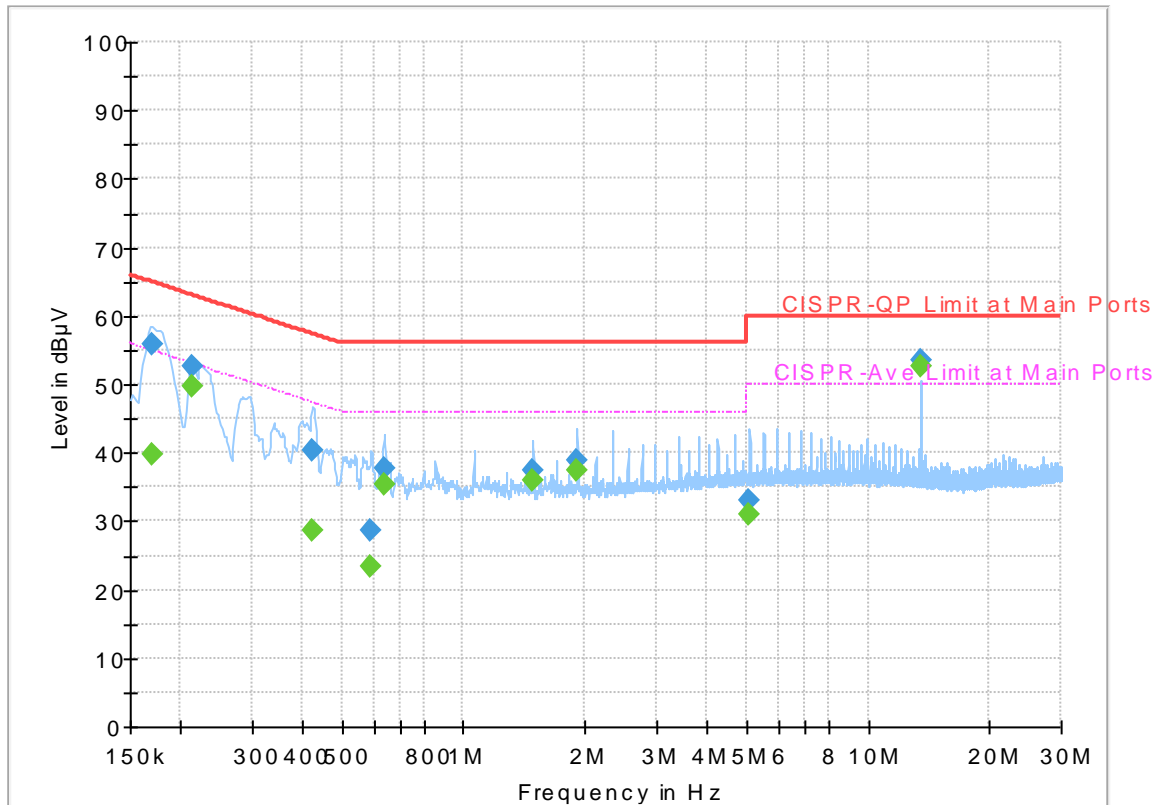

## Final\_Result

Frequency (MHz)	QuasiPeak (dBµV)	Average (dBµV)	Limit (dBµV)	Margin (dB)	Line	Filter	Corr. (dB)
0.170250	55.72	---	64.95	9.23	L1	OFF	19.5
0.170250	---	39.84	54.95	15.11	L1	OFF	19.5
0.213000	52.50	---	63.09	10.59	L1	OFF	19.5
0.213000	---	49.67	53.09	3.42	L1	OFF	19.5
0.424500	40.41	---	57.36	16.95	L1	OFF	19.5
0.424500	---	28.52	47.36	18.84	L1	OFF	19.5
0.591000	28.80	---	56.00	27.20	L1	OFF	19.5
0.591000	---	23.30	46.00	22.70	L1	OFF	19.5
0.638250	37.63	---	56.00	18.37	L1	OFF	19.5
0.638250	---	35.24	46.00	10.76	L1	OFF	19.5
1.486500	37.33	---	56.00	18.67	L1	OFF	19.6
1.486500	---	36.01	46.00	9.99	L1	OFF	19.6
1.911750	38.96	---	56.00	17.04	L1	OFF	19.6
1.911750	---	37.45	46.00	8.55	L1	OFF	19.6
5.100000	33.12	---	60.00	26.88	L1	OFF	19.6
5.100000	---	30.98	50.00	19.02	L1	OFF	19.6
13.560000	53.60	---	60.00	6.40	L1	OFF	19.7
13.560000	---	52.50	50.00	-2.50	L1	OFF	19.7

# EUT Information

Report NO : 811821-09  
 Test Mode : Mode 2  
 Test Voltage : 120Vac/60Hz  
 Phase : Neutral  
 Original Mode

Full Spectrum

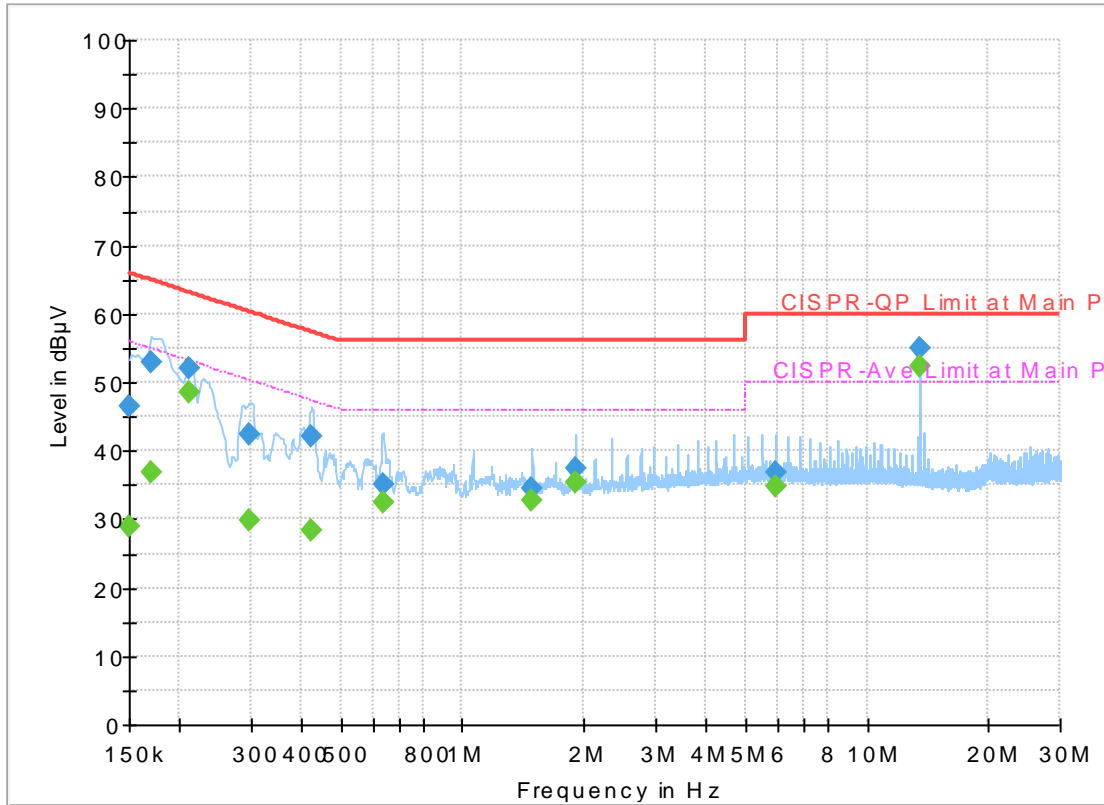

## Final\_Result

Frequency (MHz)	QuasiPeak (dBµV)	Average (dBµV)	Limit (dBµV)	Margin (dB)	Line	Filter	Corr. (dB)
0.150000	46.47	---	66.00	19.53	N	OFF	19.5
0.150000	---	29.09	56.00	26.91	N	OFF	19.5
0.170250	52.81	---	64.95	12.14	N	OFF	19.5
0.170250	---	36.73	54.95	18.22	N	OFF	19.5
0.210750	52.03	---	63.18	11.15	N	OFF	19.5
0.210750	---	48.60	53.18	4.58	N	OFF	19.5
0.296250	42.30	---	60.35	18.05	N	OFF	19.5
0.296250	---	29.84	50.35	20.51	N	OFF	19.5
0.424500	42.00	---	57.36	15.36	N	OFF	19.5
0.424500	---	28.50	47.36	18.86	N	OFF	19.5
0.638250	35.08	---	56.00	20.92	N	OFF	19.5
0.638250	---	32.41	46.00	13.59	N	OFF	19.5
1.484250	34.51	---	56.00	21.49	N	OFF	19.5
1.484250	---	32.71	46.00	13.29	N	OFF	19.5
1.909500	37.44	---	56.00	18.56	N	OFF	19.6
1.909500	---	35.50	46.00	10.50	N	OFF	19.6
5.941500	36.83	---	60.00	23.17	N	OFF	19.6
5.941500	---	34.72	50.00	15.28	N	OFF	19.6
13.560000	54.91	---	60.00	5.09	N	OFF	19.8
13.560000	---	52.40	50.00	-2.40	N	OFF	19.8

# EUT Information

Report NO : 733129-89  
 Test Mode : Mode 2  
 Test Voltage : 120Vac/60Hz  
 Phase : Line  
 Terminal Mode

Full Spectrum

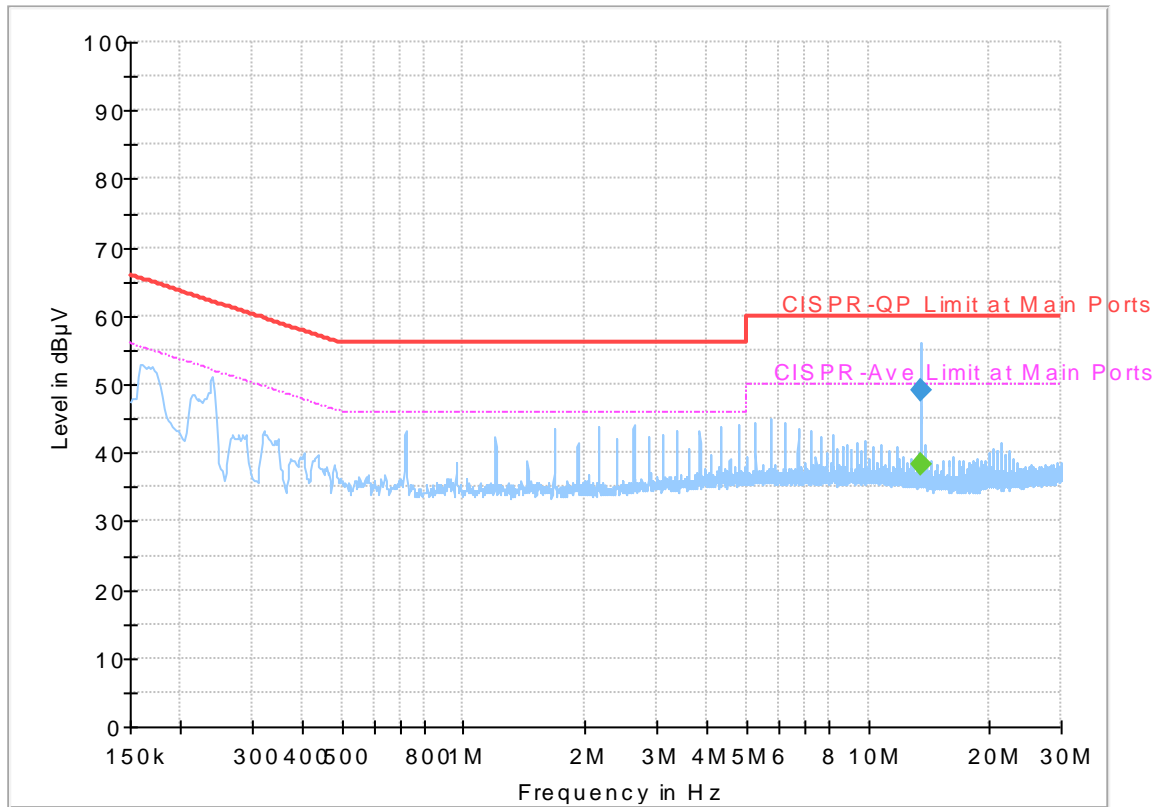

## Final\_Result

Frequency (MHz)	QuasiPeak (dBµV)	Average (dBµV)	Limit (dBµV)	Margin (dB)	Line	Filter	Corr. (dB)
13.560000	49.23	---	60.00	10.77	L1	OFF	19.7
13.560000	---	38.26	50.00	11.74	L1	OFF	19.7

## EUT Information

Report NO : 733129-89  
 Test Mode : Mode 2  
 Test Voltage : 120Vac/60Hz  
 Phase : Neutral  
 Terminal Mode

Full Spectrum

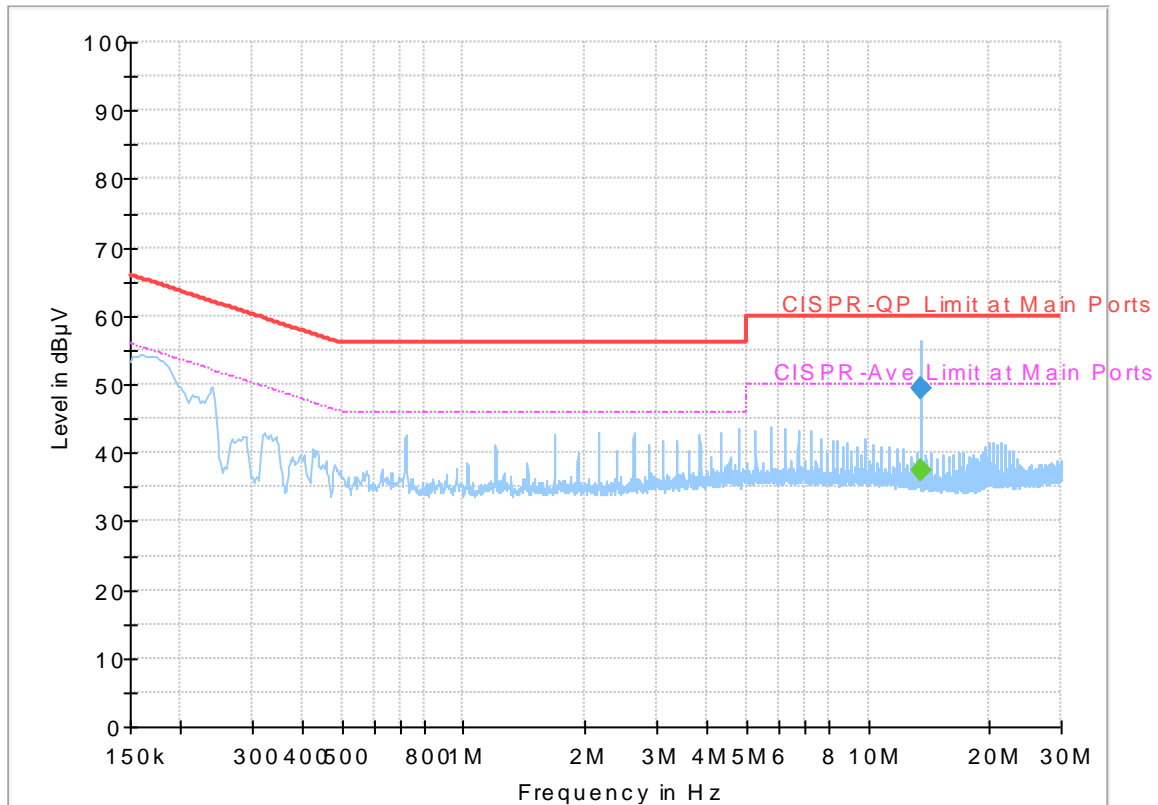

## Final\_Result

Frequency (MHz)	QuasiPeak (dBµV)	Average (dBµV)	Limit (dBµV)	Margin (dB)	Line	Filter	Corr. (dB)
13.560000	49.55	---	50.00	0.45	N	OFF	19.8
13.560000	---	37.56	60.00	22.44	N	OFF	19.8

## Appendix B. Test Results of Radiated Test Items

### B1. Test Result of Field Strength of Fundamental Emissions

<WPC Charging Mode>

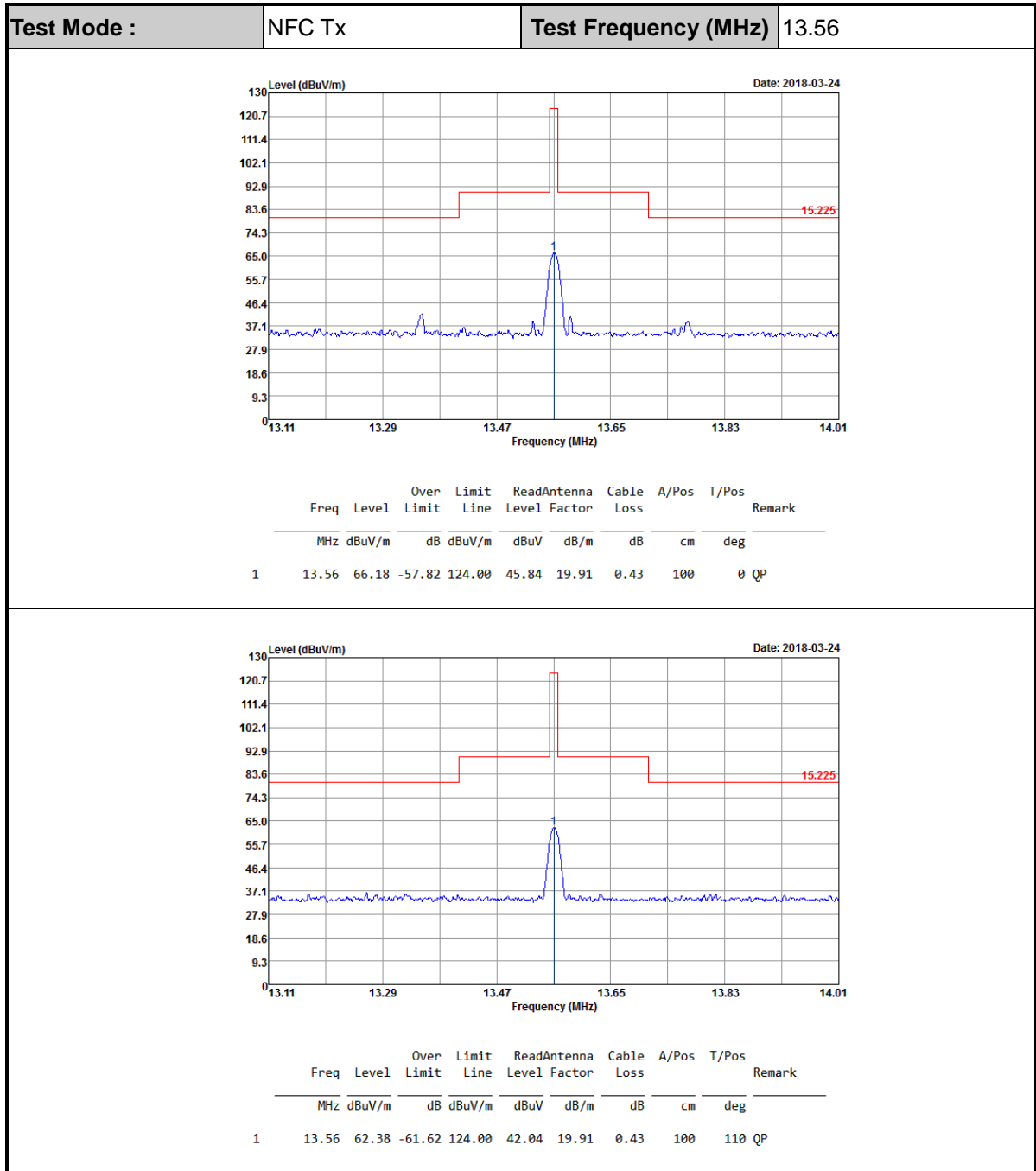



<PMA Charging Mode>

Test Mode :	NFC Tx	Test Frequency (MHz)	13.56																																
<table border="1"> <thead> <tr> <th>Over</th> <th>Limit</th> <th>ReadAntenna</th> <th>Cable</th> <th>A/Pos</th> <th>T/Pos</th> <th>Remark</th> </tr> <tr> <th>Freq</th> <th>Level</th> <th>Line</th> <th>Level</th> <th>Loss</th> <th></th> <th></th> </tr> <tr> <th>MHz</th> <th>dBuV/m</th> <th>dB</th> <th>dBuV</th> <th>dB/m</th> <th>cm</th> <th>deg</th> </tr> </thead> <tbody> <tr> <td>1</td> <td>13.56</td> <td>54.47</td> <td>-69.53</td> <td>124.00</td> <td>34.13</td> <td>19.91</td> <td>0.43</td> <td>100</td> <td>0</td> <td>QP</td> </tr> </tbody> </table>				Over	Limit	ReadAntenna	Cable	A/Pos	T/Pos	Remark	Freq	Level	Line	Level	Loss			MHz	dBuV/m	dB	dBuV	dB/m	cm	deg	1	13.56	54.47	-69.53	124.00	34.13	19.91	0.43	100	0	QP
Over	Limit	ReadAntenna	Cable	A/Pos	T/Pos	Remark																													
Freq	Level	Line	Level	Loss																															
MHz	dBuV/m	dB	dBuV	dB/m	cm	deg																													
1	13.56	54.47	-69.53	124.00	34.13	19.91	0.43	100	0	QP																									
<table border="1"> <thead> <tr> <th>Over</th> <th>Limit</th> <th>ReadAntenna</th> <th>Cable</th> <th>A/Pos</th> <th>T/Pos</th> <th>Remark</th> </tr> <tr> <th>Freq</th> <th>Level</th> <th>Line</th> <th>Level</th> <th>Loss</th> <th></th> <th></th> </tr> <tr> <th>MHz</th> <th>dBuV/m</th> <th>dB</th> <th>dBuV</th> <th>dB/m</th> <th>cm</th> <th>deg</th> </tr> </thead> <tbody> <tr> <td>1</td> <td>13.56</td> <td>48.70</td> <td>-75.30</td> <td>124.00</td> <td>28.36</td> <td>19.91</td> <td>0.43</td> <td>100</td> <td>98</td> <td>QP</td> </tr> </tbody> </table>				Over	Limit	ReadAntenna	Cable	A/Pos	T/Pos	Remark	Freq	Level	Line	Level	Loss			MHz	dBuV/m	dB	dBuV	dB/m	cm	deg	1	13.56	48.70	-75.30	124.00	28.36	19.91	0.43	100	98	QP
Over	Limit	ReadAntenna	Cable	A/Pos	T/Pos	Remark																													
Freq	Level	Line	Level	Loss																															
MHz	dBuV/m	dB	dBuV	dB/m	cm	deg																													
1	13.56	48.70	-75.30	124.00	28.36	19.91	0.43	100	98	QP																									

**B2. Results of Radiated Spurious Emissions (9 kHz~30MHz)**

<WPC Charging Mode>

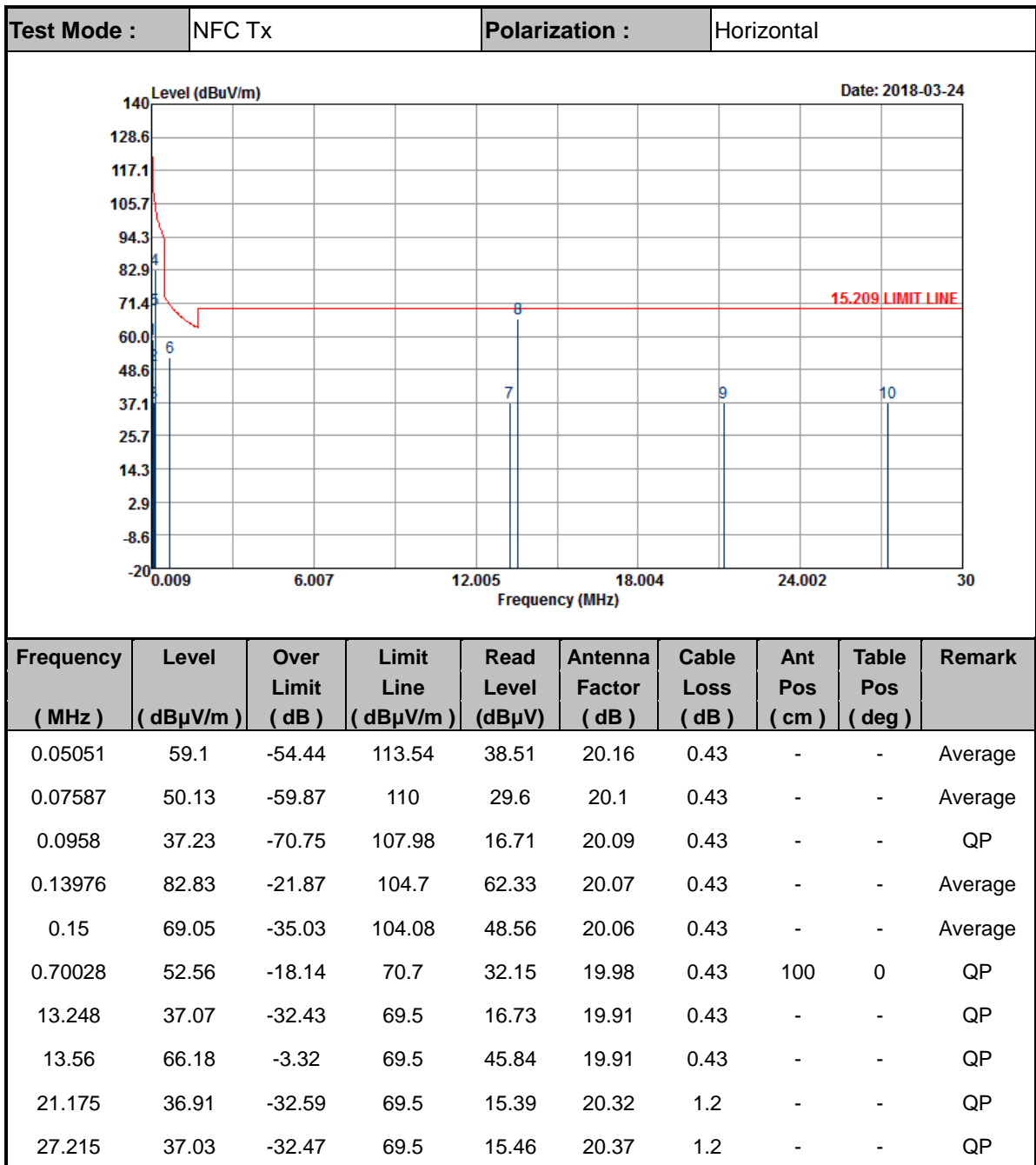

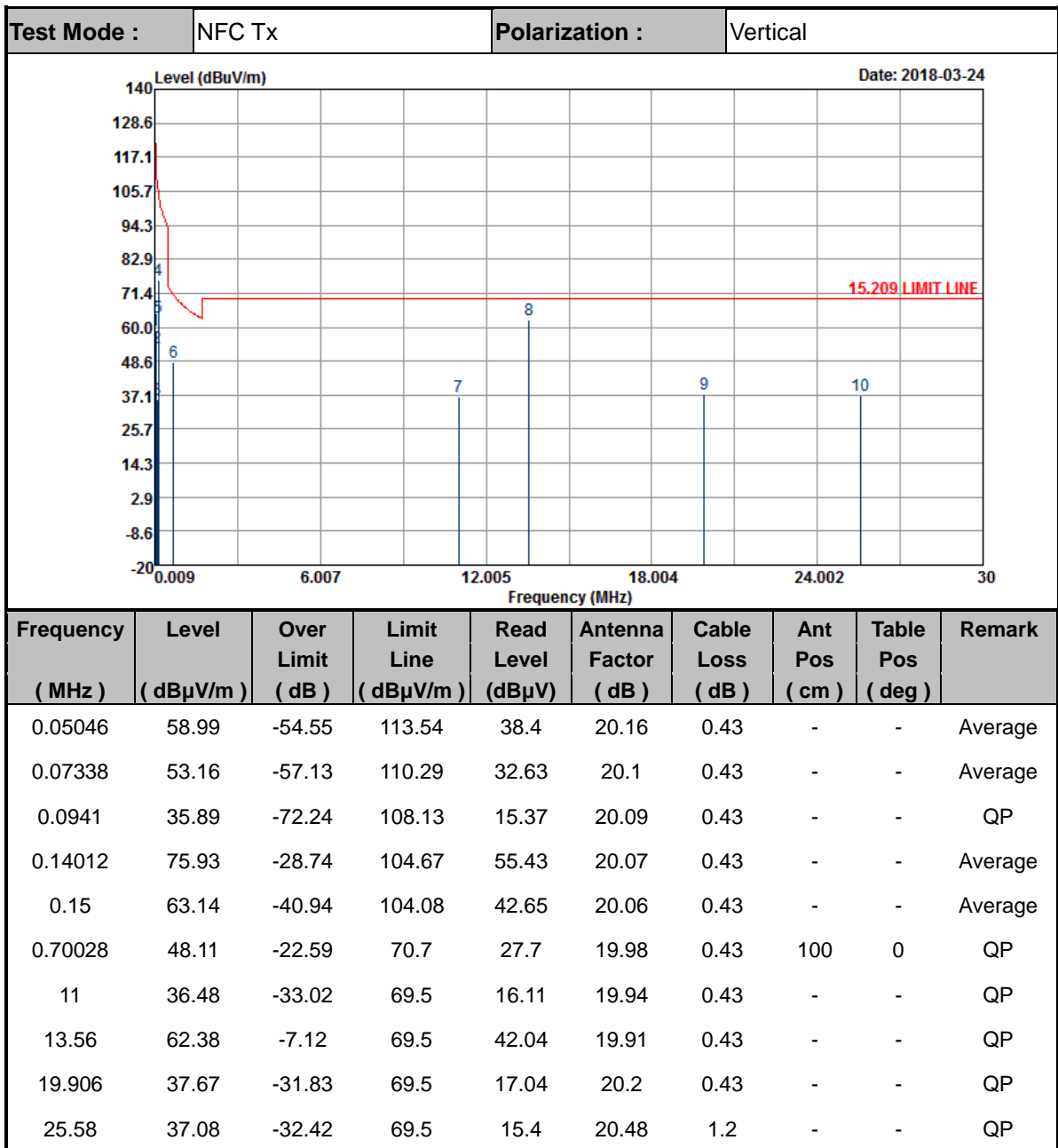

**Note:**

1. 13.56 MHz is fundamental signal which can be ignored.
2. The amplitude of spurious emissions which are attenuated by more than 20dB below the permissible value has no need to be reported.
3. Distance extrapolation factor = 40 log (specific distance / test distance) (dB);
4. Limit line = specific limits (dBuV) + distance extrapolation factor.



<PMA Charging Mode>

Test Mode :	NFC Tx	Polarization :	Horizontal
-------------	--------	----------------	------------

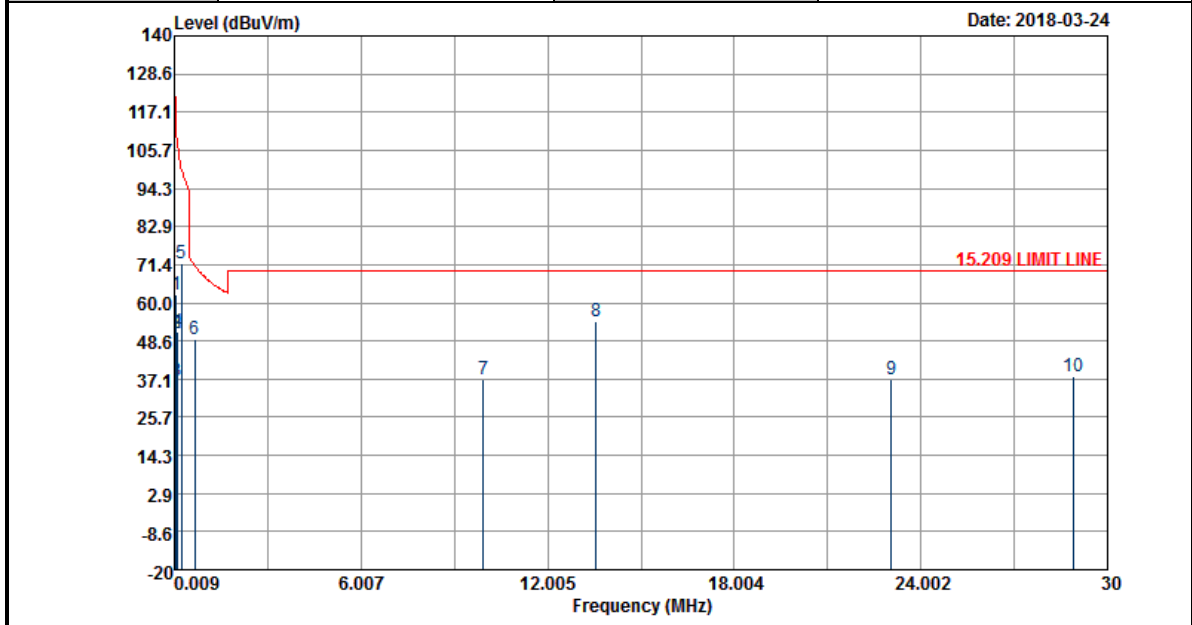

Frequency ( MHz )	Level ( dBμV/m )	Over Limit ( dB )	Limit Line ( dBμV/m )	Read Level ( dBμV )	Antenna Factor ( dB )	Cable Loss ( dB )	Ant Pos ( cm )	Table Pos ( deg )	Remark
0.05847	62.53	-49.74	112.27	42	20.1	0.43	-	-	Average
0.07515	50.82	-59.27	110.09	30.29	20.1	0.43	-	-	Average
0.09022	36.74	-71.76	108.5	16.22	20.09	0.43	-	-	QP
0.11588	51.41	-54.91	106.32	30.91	20.07	0.43	-	-	Average
0.2248	71.66	-28.91	100.57	51.2	20.03	0.43	-	-	Average
0.67024	49.17	-21.91	71.08	28.76	19.98	0.43	100	0	QP
9.936	37.15	-32.35	69.5	16.77	19.95	0.43	-	-	QP
13.56	54.47	-15.03	69.5	34.13	19.91	0.43	-	-	QP
23.056	37.15	-32.35	69.5	15.5	20.45	1.2	-	-	QP
28.89	37.91	-31.59	69.5	16.56	20.15	1.2	-	-	QP

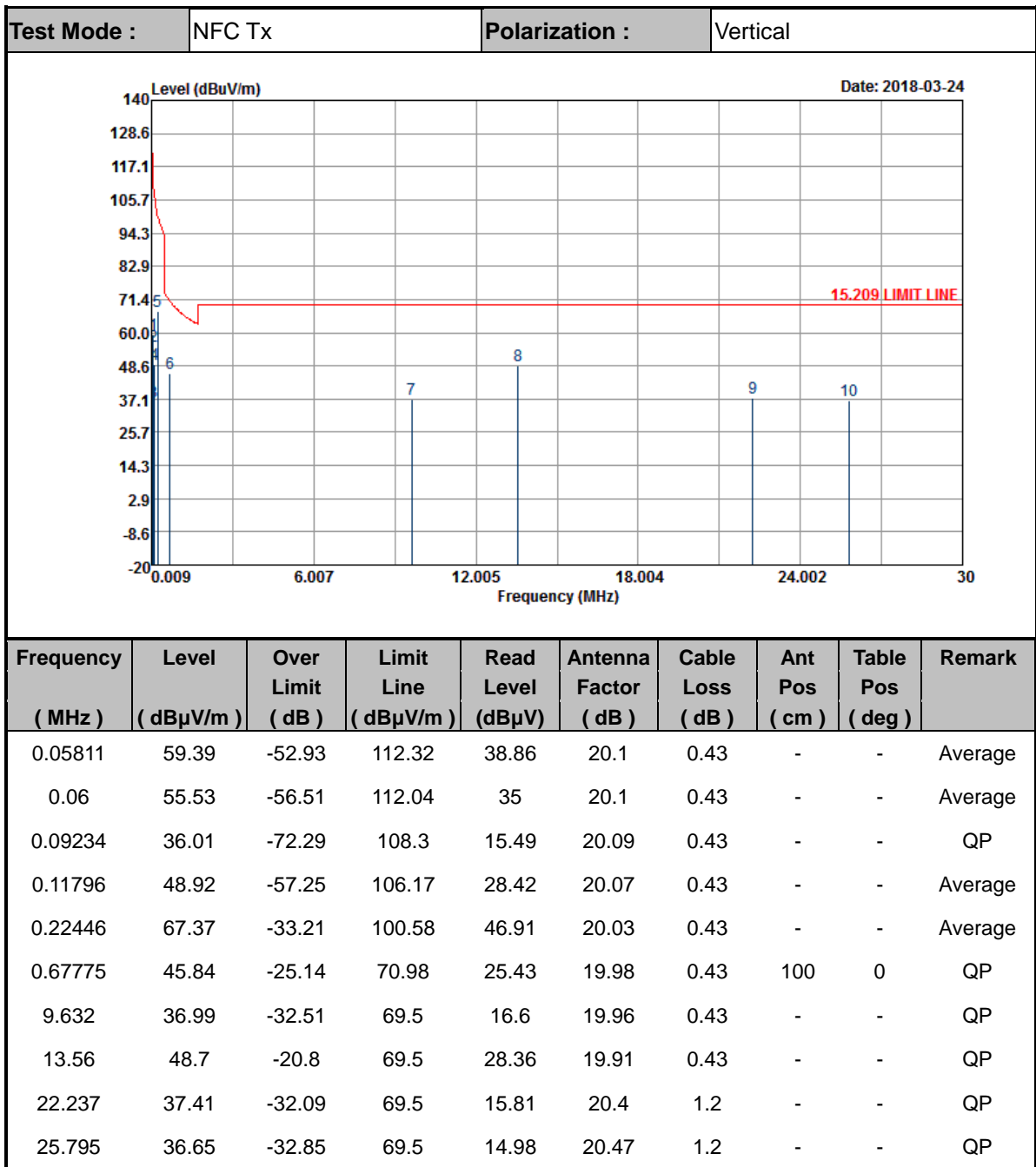

**Note:**

1. 13.56 MHz is fundamental signal which can be ignored.
2. The amplitude of spurious emissions which are attenuated by more than 20dB below the permissible value has no need to be reported.
3. Distance extrapolation factor = 40 log (specific distance / test distance) (dB);
4. Limit line = specific limits (dBμV) + distance extrapolation factor.



**B3.Results of Radiated Spurious Emissions (30MHz~1GHz)**

<WPC Charging Mode>

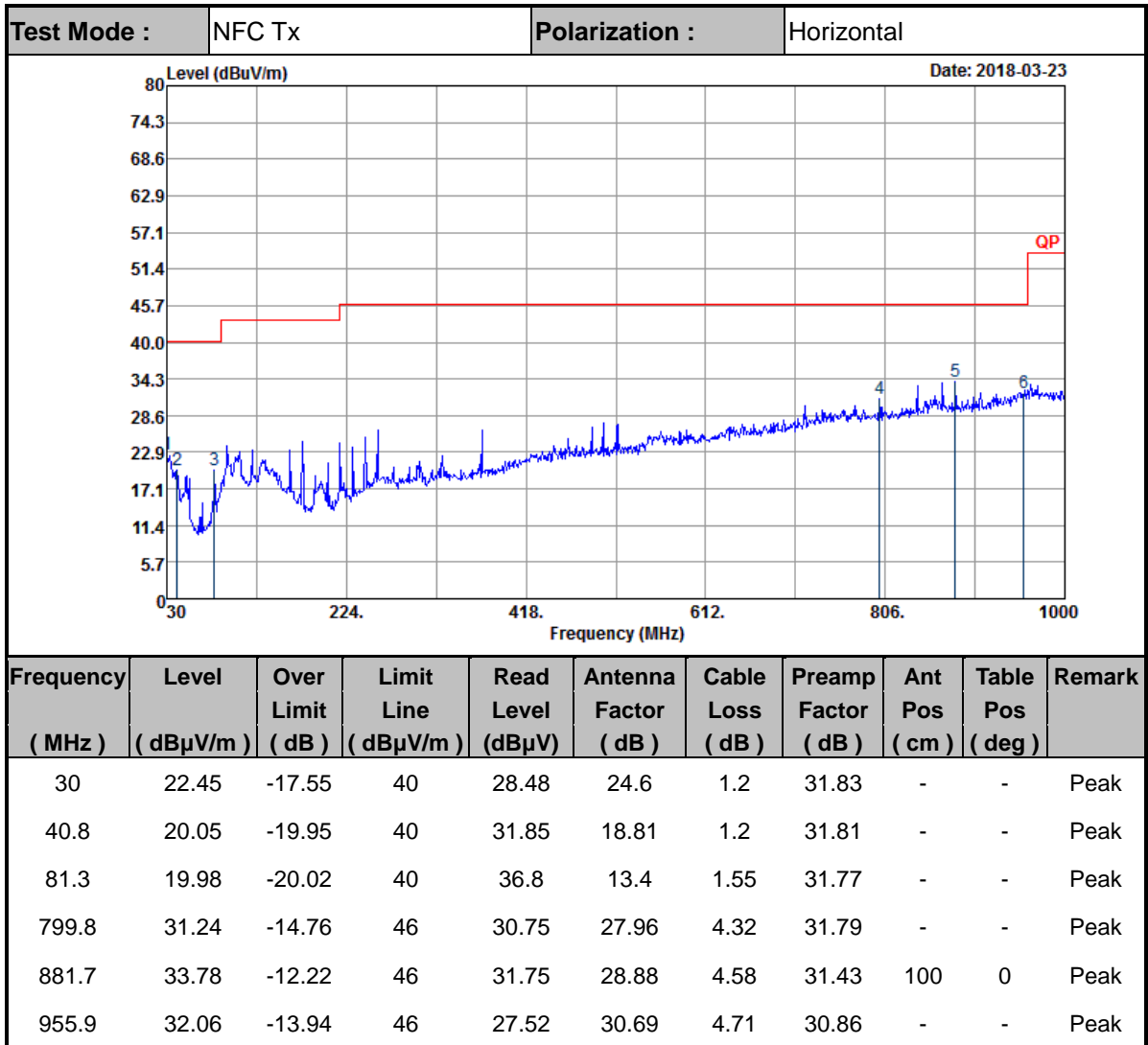

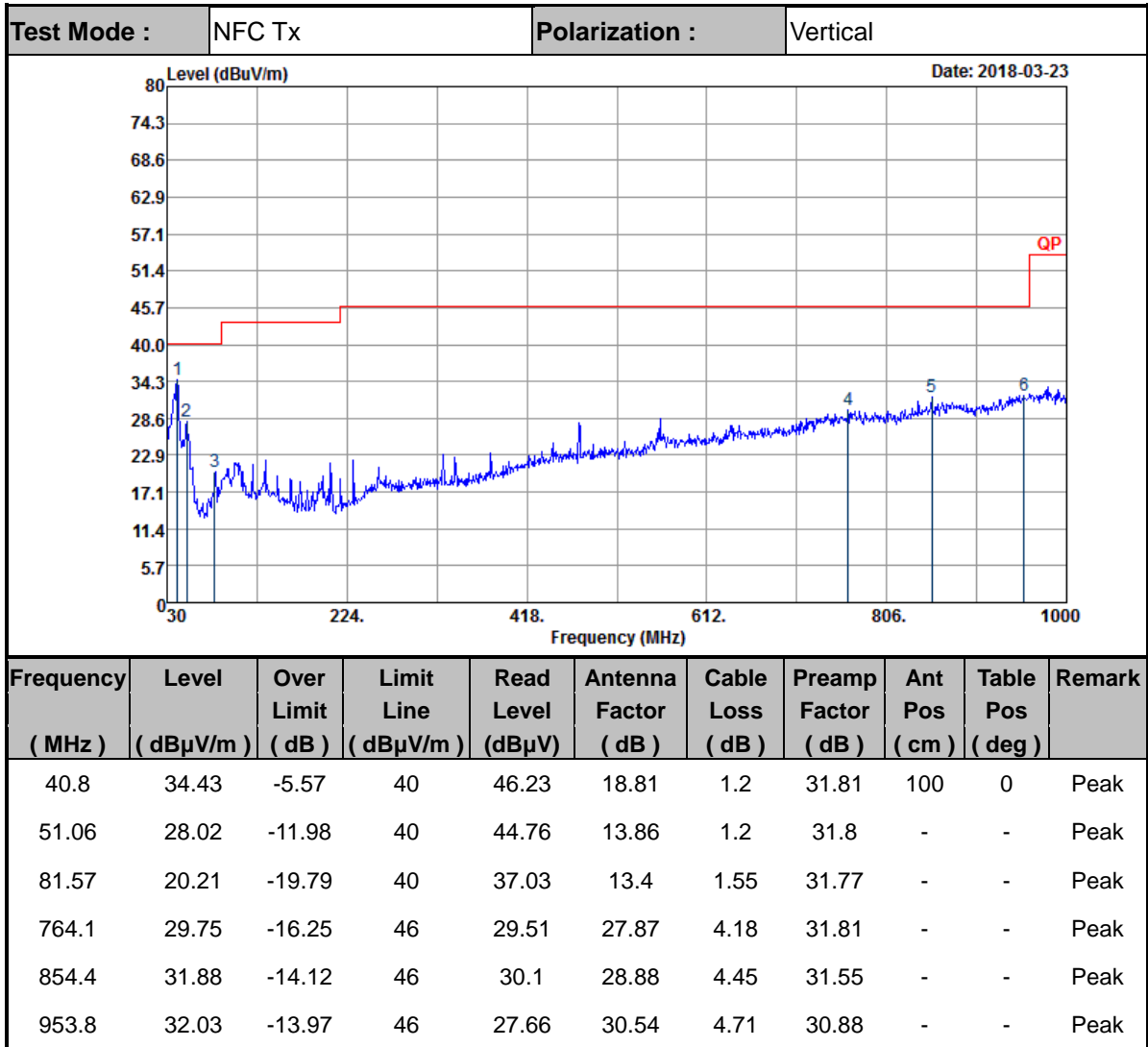

**Note:**

1. The amplitude of spurious emissions which are attenuated by more than 20dB below the permissible value has no need to be reported.
2. Emission level (dBμV/m) = 20 log Emission level (μV/m).
3. Corrected Reading: Antenna Factor + Cable Loss + Read Level - Preamp Factor= Level.



<PMA Charging Mode>

Test Mode :	NFC Tx	Polarization :	Horizontal
-------------	--------	----------------	------------

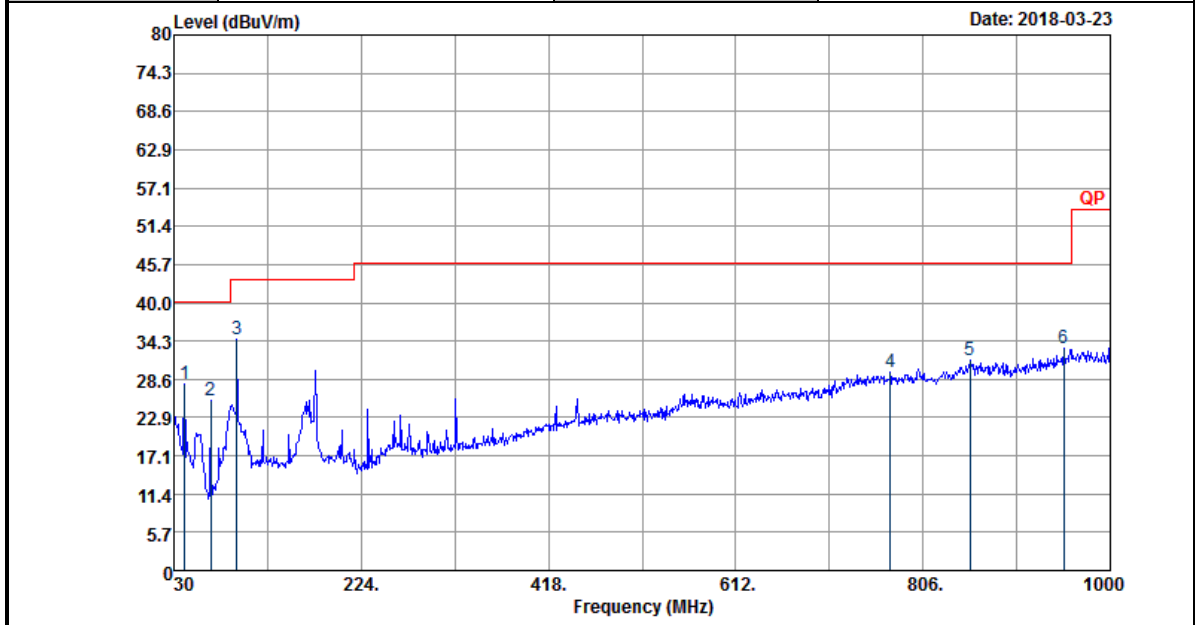

Frequency ( MHz )	Level ( dB $\mu$ V/m )	Over Limit ( dB )	Limit Line ( dB $\mu$ V/m )	Read Level ( dB $\mu$ V )	Antenna Factor ( dB )	Cable Loss ( dB )	Preamp Factor ( dB )	Ant Pos ( cm )	Table Pos ( deg )	Remark
40.8	27.79	-12.21	40	39.59	18.81	1.2	31.81	-	-	Peak
67.8	25.42	-14.58	40	43.51	12.14	1.55	31.78	-	-	Peak
94.8	34.52	-8.98	43.5	49.51	15.21	1.55	31.75	100	0	Peak
771.8	29.66	-16.34	46	29.37	27.92	4.18	31.81	-	-	Peak
854.4	31.45	-14.55	46	29.67	28.88	4.45	31.55	-	-	Peak
951.7	33.18	-12.82	46	28.93	30.44	4.71	30.9	-	-	Peak

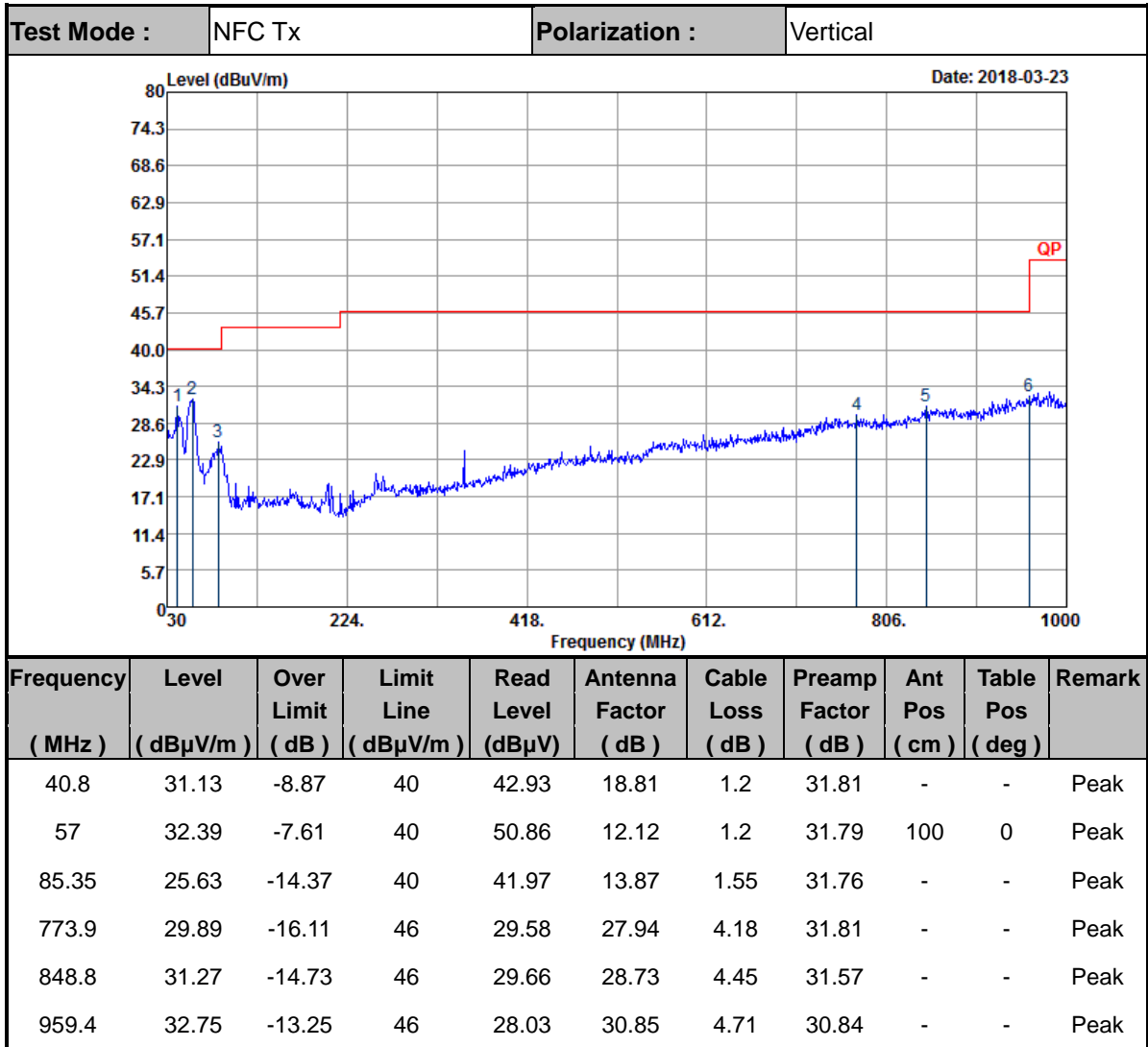

**Note:**

1. The amplitude of spurious emissions which are attenuated by more than 20dB below the permissible value has no need to be reported.
2. Emission level (dBμV/m) = 20 log Emission level (μV/m).
3. Corrected Reading: Antenna Factor + Cable Loss + Read Level - Preamp Factor= Level