



# FCC Test Report

**APPLICANT** : Motorola Mobility LLC  
**EQUIPMENT** : Mobile Cellular Phone  
**BRAND NAME** : Motorola  
**MODEL NAME** : XT1921-2  
**FCC ID** : IHDT56XC4  
**STANDARD** : FCC 47 CFR FCC Part 15 Subpart B  
**CLASSIFICATION** : Certification

The product was received on Dec. 20, 2017 and testing was completed on Jan. 08, 2018. We, Sporton International (Kunshan) Inc., would like to declare that the tested sample has been evaluated in accordance with the test procedures given in ANSI C63.4-2014 and has been in compliance with the applicable technical standards.

The test results in this report apply exclusively to the tested model / sample. Without written approval of Sporton International (Kunshan) Inc., the test report shall not be reproduced except in full.



Approved by: James Huang / Manager

**Sporton International (Kunshan) Inc.**  
**No.3-2 Ping-Xiang Rd, Kunshan Development Zone Kunshan City Jiangsu Province 215335**  
**China**



# TABLE OF CONTENTS

**REVISION HISTORY ..... 3**

**SUMMARY OF TEST RESULT ..... 4**

**1. GENERAL DESCRIPTION ..... 5**

    1.1. Applicant..... 5

    1.2. Manufacturer ..... 5

    1.3. Product Feature of Equipment Under Test ..... 5

    1.4. Product Specification of Equipment Under Test ..... 6

    1.5. Modification of EUT ..... 7

    1.6. Specification of Accessory ..... 7

    1.7. Test Location ..... 8

    1.8. Applicable Standards ..... 8

**2. TEST CONFIGURATION OF EQUIPMENT UNDER TEST ..... 9**

    2.1. Test Mode ..... 9

    2.2. Connection Diagram of Test System ..... 11

    2.3. Support Unit used in test configuration and system ..... 13

    2.4. EUT Operation Test Setup ..... 13

**3. TEST RESULT ..... 14**

    3.1. Test of AC Conducted Emission Measurement ..... 14

    3.2. Test of Radiated Emission Measurement ..... 21

**4. LIST OF MEASURING EQUIPMENT ..... 27**

**5. UNCERTAINTY OF EVALUATION ..... 28**

**APPENDIX A. SETUP PHOTOGRAPHS**



### REVISION HISTORY

REPORT NO.	VERSION	DESCRIPTION	ISSUED DATE
FC7D2001-02	Rev. 01	Initial issue of report	Feb. 14, 2018



### SUMMARY OF TEST RESULT

Report Section	FCC Rule	Description	Limit	Result	Remark
3.1	15.107	AC Conducted Emission	< 15.107 limits	PASS	Under limit 8.59 dB at 0.167 MHz
3.2	15.109	Radiated Emission	< 15.109 limits	PASS	Under limit 5.96 dB at 42.960 MHz



# 1. General Description

## 1.1. Applicant

Motorola Mobility LLC  
222 W, Merchandise Mart Plaza, Chicago IL 60654 USA

## 1.2. Manufacturer

Motorola Mobility LLC  
222 W, Merchandise Mart Plaza, Chicago IL 60654 USA

## 1.3. Product Feature of Equipment Under Test

Product Feature	
Equipment	Mobile Cellular Phone
Brand Name	Motorola
Model Name	XT1921-2
FCC ID	IHDT56XC4
EUT supports Radios application	GSM/GPRS/EGPRS/WCDMA/HSPA/DC-HSDPA/ HSPA+(16QAM uplink is not supported)/LTE/ WLAN 2.4GHz 802.11b/g/n HT20/ WLAN 5GHz 802.11a/n HT20/HT40/ Bluetooth v3.0 + EDR/Bluetooth v4.0 LE/ Bluetooth v4.1 LE/Bluetooth v4.2 LE
IMEI Code	Conduction: 351840090011507 Radiation: 351840090009832
HW Version	DVT1B
SW Version	fastboot_james_a_oem_a_userdebug_8.0.0_OCP27.62_9 91_intcfg-test-keys_a.tar.gz
EUT Stage	Identical Prototype

**Remark:** The above EUT's information was declared by manufacturer. Please refer to the specifications or user's manual for more detailed description.



### 1.4. Product Specification of Equipment Under Test

Standards-related Product Specification	
<b>Tx Frequency</b>	GSM850: 824.2 MHz ~ 848.8 MHz GSM1900: 1850.2 MHz ~ 1909.8MHz WCDMA Band V: 826.4 MHz ~ 846.6 MHz WCDMA Band IV : 1712.4 MHz ~ 1752.6 MHz WCDMA Band II: 1852.4 MHz ~ 1907.6 MHz LTE Band 2 : 1850.7 MHz ~ 1909.3 MHz LTE Band 4 : 1710.7 MHz ~ 1754.3 MHz LTE Band 5 : 824.7 MHz ~ 848.3 MHz LTE Band 12 : 699.7 MHz ~ 715.3 MHz LTE Band 14 : 790.5 MHz ~ 795.5 MHz LTE Band 17 : 706.5 MHz ~ 713.5 MHz LTE Band 30 : 2307.5 MHz ~ 2312.5 MHz LTE Band 66 : 1710.7 MHz ~ 1779.3 MHz 802.11b/g/n: 2412 MHz ~ 2462 MHz 802.11a/n: 5180 MHz ~ 5240 MHz; 5260 MHz ~ 5320 MHz; 5500 MHz ~ 5700 MHz; 5745 MHz ~ 5825 MHz Bluetooth: 2402 MHz ~ 2480 MHz
<b>Rx Frequency</b>	GSM850: 869.2 MHz ~ 893.8 MHz GSM1900: 1930.2 MHz ~ 1989.8 MHz WCDMA Band V: 871.4 MHz ~ 891.6 MHz WCDMA Band IV : 2112.4 MHz ~ 2152.6 MHz WCDMA Band II: 1932.4 MHz ~ 1987.6 MHz LTE Band 2 : 1930.7 MHz ~ 1989.3 MHz LTE Band 4 : 2110.7 MHz ~ 2154.3 MHz LTE Band 5 : 869.7 MHz ~ 893.3 MHz LTE Band 12 : 729.7 MHz ~ 745.3 MHz LTE Band 14 : 760.5 MHz ~ 765.5 MHz LTE Band 17 : 736.5 MHz ~ 743.5 MHz LTE Band 30 : 2352.5 MHz ~ 2357.5 MHz LTE Band 66 : 2110.7 MHz ~ 2179.3 MHz 802.11b/g/n: 2412 MHz ~ 2462 MHz 802.11a/n: 5180 MHz ~ 5240 MHz; 5260 MHz ~ 5320 MHz; 5500 MHz ~ 5700 MHz; 5745 MHz ~ 5825 MHz Bluetooth: 2402 MHz ~ 2480 MHz GNSS : 1559 MHz ~ 1610 MHz FM : 88 MHz ~ 108 MHz
<b>Antenna Type</b>	WWAN : PIFA Antenna WLAN : PIFA Antenna Bluetooth : PIFA Antenna GNSS: PIFA Antenna FM: External headset Antenna
<b>Type of Modulation</b>	GSM: GMSK GPRS: GMSK EDGE(MCS 0-4): GMSK / (MCS 5-9): 8PSK WCDMA : BPSK (Uplink) HSDPA/DC-HSDPA : QPSK (Uplink) HSUPA : QPSK (Uplink) HSPA+ : 16QAM (uplink is not supported) DC-HSDPA : 64QAM LTE: QPSK / 16QAM / 64QAM



	802.11b : DSSS (DBPSK / DQPSK / CCK) 802.11a/g/n : OFDM (BPSK / QPSK / 16QAM / 64QAM) Bluetooth LE : GFSK Bluetooth (1Mbps) : GFSK Bluetooth (2Mbps) : $\pi/4$ -DQPSK Bluetooth (3Mbps) : 8-DPSK GNSS : BPSK FM
--	--

Note: GNSS Rx = GPS Rx + Glonass Rx

### 1.5. Modification of EUT

No modifications are made to the EUT during all test items.

### 1.6. Specification of Accessory

Specification of Accessory				
AC Adapter 1	Brand Name	Motorola (Chenyang)	Model Name	C-P56 ( SA18C22623)
	Power Rating	I/P: 100-240 Vac, 130mA, O/P: 5Vdc,1000mA		
AC Adapter 2	Brand Name	Motorola (Acbel)	Model Name	C-P56 (SA18C27121)
	Power Rating	I/P: 100-240 Vac, 130mA, O/P: 5Vdc,1000mA		
Battery	Brand Name	Motorola (Motorola)	Model Name	GK40
	Power Rating	3.8Vdc,2685/2800mAh	Type	Li-ion
USB Cable	Brand Name	Motorola (Saibao)	Model Name	SWT-A083A
	Signal Line Type	1.0 meter, shielded cable, without ferrite core		



### 1.7. Test Location

Sporton International (Kunshan) Inc. is accredited to ISO 17025 by National Voluntary Laboratory Accreditation Program (NVLAP code: 600155-0) and the FCC designation No. is CN5013.

<b>Test Site</b>	Sporton International (Kunshan) Inc.		
<b>Test Site Location</b>	No.3-2 Ping-Xiang Rd, Kunshan Development Zone Kunshan City Jiangsu Province 215335 China TEL : +86-512-57900158 FAX : +86-512-57900958		
<b>Test Site No.</b>	<b>Sporton Site No.</b>		<b>FCC Test Firm Registration No.</b>
	CO01-KS	03CH02-KS	630927

**Note:** The test site complies with ANSI C63.4 2014 requirement.

### 1.8. Applicable Standards

According to the specifications of the manufacturer, the EUT must comply with the requirements of the following standards:

- FCC 47 CFR FCC Part 15 Subpart B
- ANSI C63.4-2014

**Remark:** All test items were verified and recorded according to the standards and without any deviation during the test.



## 2. Test Configuration of Equipment Under Test

### 2.1. Test Mode

The EUT has been associated with peripherals pursuant to ANSI C63.4-2014 and configuration operated in a manner tended to maximize its emission characteristics in a typical application.

Frequency range investigated: conduction (150 kHz to 30 MHz), radiation (30MHz to the 5th harmonic of the highest fundamental frequency or to 40 GHz, whichever is lower).

Test Items	Function Type
AC Conducted Emission	Mode 1: GSM850 Idle + Bluetooth Idle + WLAN (2.4G) Idle + USB Cable (Charging from Adapter 1) + Earphone + Battery + Camera (Rear) <Fig.1>
	Mode 2: GSM1900 Idle + Bluetooth Idle + WLAN (5G) Idle + USB Cable (Charging from Adapter 1) + Earphone + Battery + Camera (Front) <Fig.1>
	Mode 3: WCDMA Band V Idle + Bluetooth Idle + WLAN (2.4G) Idle + USB Cable (Charging from Adapter 1) + Earphone + Battery + MPEG4<Fig.1>
	Mode 4: WCDMA Band II Idle + Bluetooth Idle + WLAN (5G) Idle + USB Cable (Charging from Adapter 1) + Earphone + Battery + GNSS Rx<Fig.2>
	Mode 5: GSM850 Idle + Bluetooth Idle + WLAN (2.4G) Idle + USB Cable (Charging from Adapter 2) + Earphone + Battery + Camera (Rear) <Fig.1>
	Mode 6: LTE Band 17 Idle + Bluetooth Idle + WLAN (2.4G) Idle + USB Cable (Data Link with Notebook) + Earphone + Battery + GNSS Rx<Fig.3>
	Mode 7: USB Cable (Charging from Adapter 1) + FM Rx (88MHz) + Earphone + Battery<Fig.4>
	Mode 8: USB Cable (Charging from Adapter 1) + FM Rx (98MHz) + Earphone + Battery<Fig.4>
	Mode 9: USB Cable (Charging from Adapter 1) + FM Rx (108MHz) + Earphone + Battery<Fig.4>
	Mode 10 : USB Cable (Charging from Adapter 2) + FM Rx (98MHz) + Earphone + Battery<Fig.4>



<p>Radiated Emissions &lt; 1GHz</p>	<p>Mode 1: GSM850 Idle + Bluetooth Idle + WLAN (2.4G) Idle + USB Cable (Charging from Adapter 1) + Earphone + Battery + Camera (Rear) &lt;Fig.1&gt;</p> <p>Mode 2: GSM1900 Idle + Bluetooth Idle + WLAN (5G) Idle + USB Cable (Charging from Adapter 1) + Earphone + Battery + Camera (Front) &lt;Fig.1&gt;</p> <p>Mode 3: WCDMA Band V Idle + Bluetooth Idle + WLAN (2.4G) Idle + USB Cable (Charging from Adapter 1) + Earphone + Battery + MPEG4&lt;Fig.1&gt;</p> <p>Mode 4: WCDMA Band II Idle + Bluetooth Idle + WLAN (5G) Idle + USB Cable (Charging from Adapter 1) + Earphone + Battery + GNSS Rx&lt;Fig.2&gt;</p> <p>Mode 5: GSM850 Idle + Bluetooth Idle + WLAN (2.4G) Idle + USB Cable (Charging from Adapter 2) + Earphone + Battery + Camera (Rear) &lt;Fig.1&gt;</p> <p>Mode 6: LTE Band 17 Idle + Bluetooth Idle + WLAN (5G) Idle + USB Cable (Data Link with Notebook) + Earphone + Battery + GNSS Rx&lt;Fig.3&gt;</p> <p>Mode 7: USB Cable (Charging from Adapter 1) + FM Rx (88MHz) + Earphone + Battery&lt;Fig.4&gt;</p> <p>Mode 8: USB Cable (Charging from Adapter 1) + FM Rx (98MHz) + Earphone + Battery&lt;Fig.4&gt;</p> <p>Mode 9: USB Cable (Charging from Adapter 1) + FM Rx (108MHz) + Earphone + Battery&lt;Fig.4&gt;</p> <p>Mode 10 : USB Cable (Charging from Adapter 2) + FM Rx (98MHz) + Earphone + Battery&lt;Fig.4&gt;</p>
<p>Radiated Emissions ≥ 1GHz</p>	<p>Mode 1: LTE Band 17 Idle + Bluetooth Idle + WLAN (5G) Idle + USB Cable (Data Link with Notebook) + Earphone + Battery + GNSS Rx&lt;Fig.3&gt;</p> <p>Mode 2: USB Cable (Charging from Adapter 2) + FM Rx (98MHz) + Earphone + Battery&lt;Fig.4&gt;</p>
<p><b>Remark:</b></p> <ol style="list-style-type: none"> <li>1. The worst case of AC is mode 5; and the USB data link mode is mode 6, the test data of these modes are reported.</li> <li>2. The worst case of RE &lt; 1G is mode 10; and the USB data link mode is mode 6, the test data of these modes are reported.</li> <li>3. Data Link with Notebook means data application transferred mode between EUT and Notebook.</li> </ol>	

## 2.2. Connection Diagram of Test System

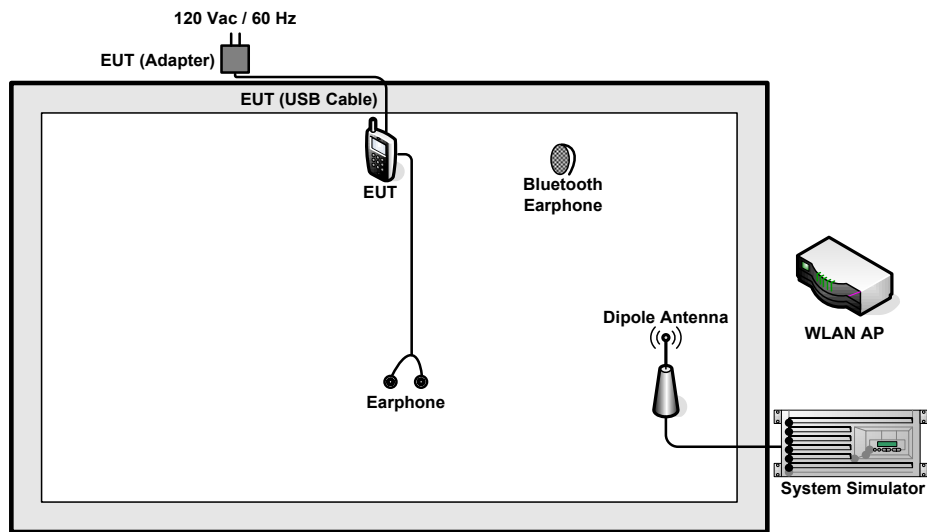

<Fig.1>

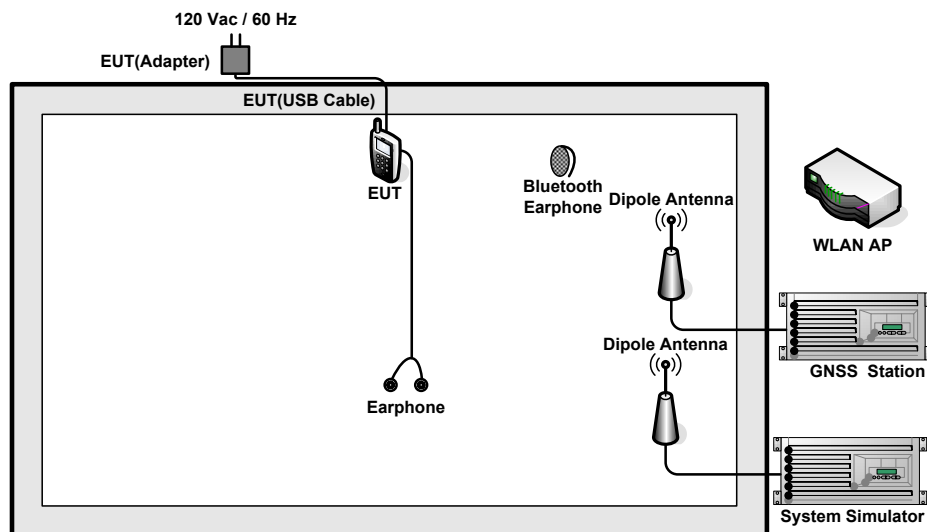

<Fig.2>

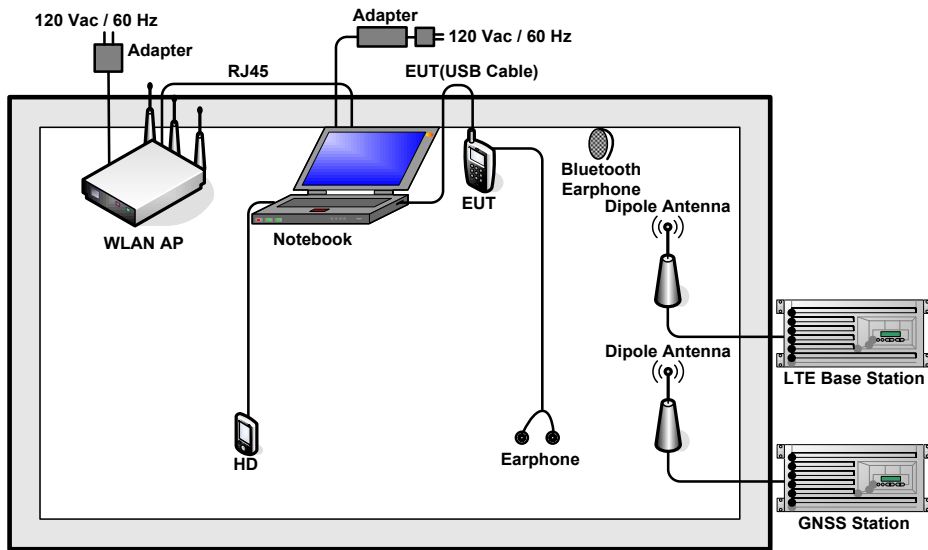

<Fig.3>

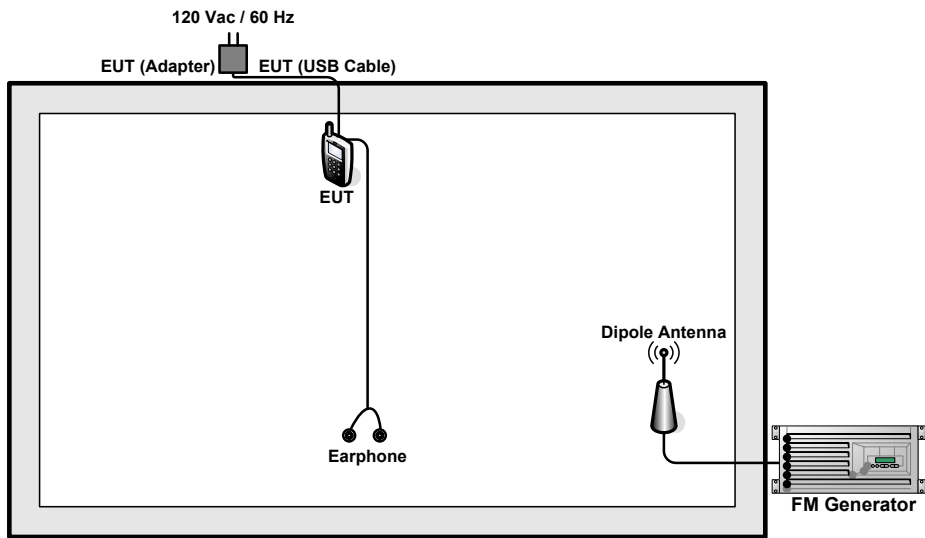

<Fig.4>

### 2.3. Support Unit used in test configuration and system

Item	Equipment	Trade Name	Model Name	FCC ID	Data Cable	Power Cord
1.	System Simulator	R&S	CMU 200	N/A	N/A	Unshielded, 1.8 m
2.	LTE Base Station	Anritsu	MT8820C	N/A	N/A	Unshielded, 1.8 m
3.	FM Generator	R&S	SMBV100A	N/A	N/A	Unshielded, 1.8 m
4.	GNSS Station	ADIVIC	MP9000	N/A	N/A	Unshielded, 1.8 m
5.	GNSS Station	RACELOGIC	RLLS03-2RP	N/A	N/A	Unshielded, 1.8 m
6.	WLAN AP	D-Link	DIR-855	KA2DIR855A2	N/A	Unshielded, 1.8 m
7.	WLAN AP	TP-Link	TL-WDR5600	N/A	N/A	Unshielded, 1.8 m
8.	Notebook	Lenovo	G480	N/A	N/A	AC I/P: Unshielded, 1.8 m DC O/P: Shielded, 1.8 m
9.	Notebook	Lenovo	Y510P	N/A	N/A	AC I/P: Unshielded, 1.8 m DC O/P: Shielded, 1.8 m
10.	Bluetooth Earphone	Lenovo	LBH308	N/A	N/A	N/A
11.	Hard Disk	Lenovo	F310	FCC DoC	Shielded, 0.5 m	N/A
12.	SD Card	SanDisk	Uitra	N/A	N/A	N/A
13.	SD Card	Kingston	8GB	N/A	N/A	N/A
14.	Earphone	Lenovo	SH100	N/A	Unshielded, 1.0 m	N/A

### 2.4. EUT Operation Test Setup

The EUT was in GSM or WCDMA or LTE idle mode during the testing. The EUT was synchronized to the BCCH, and is in continuous receiving mode by setting system simulator’s paging reorganization.

At the same time, the EUT was attached to the Bluetooth earphone or WLAN AP, and the following programs installed in the EUT were programmed during the test.

1. Data application is transferred between Notebook and EUT via USB cable.
2. Turn on GNSS function to make the EUT receive continuous signals from GNSS station.
3. Execute “Video Player” to play MPEG4 files.
4. Turn on camera to capture images.
5. The EUT was turned to Radio frequency channels, FM88 MHz, FM98 MHz and FM108 MHz, from FM Generator.



### 3. Test Result

#### 3.1. Test of AC Conducted Emission Measurement

##### 3.1.1 Limits of AC Conducted Emission

For equipment that is designed to be connected to the public utility (AC) power line, the radio frequency voltage that is conducted back onto the AC power line on any frequency or frequencies within the band 150 kHz to 30 MHz shall not exceed the limits in the following table.

Frequency of emission (MHz)	Conducted limit (dBuV)	
	Quasi-peak	Average
0.15-0.5	66 to 56*	56 to 46*
0.5-5	56	46
5-30	60	50

\*Decreases with the logarithm of the frequency.

##### 3.1.2 Measuring Instruments

The measuring equipment is listed in the section 4 of this test report.

##### 3.1.3 Test Procedure

1. The EUT was placed 0.4 meter from the conducting wall of the shielding room was kept at least 80 centimeters from any other grounded conducting surface.
2. Connect EUT to the power mains through a line impedance stabilization network (LISN).
3. All the support units are connecting to the other LISN.
4. The LISN provides 50 ohm coupling impedance for the measuring instrument.
5. The FCC states that a 50 ohm, 50 microhenry LISN should be used.
6. Both sides of AC line were checked for maximum conducted interference.
7. The frequency range from 150 kHz to 30 MHz was searched.
8. Set the test-receiver system to Peak Detect Function and specified bandwidth (IF Bandwidth = 9kHz) with Maximum Hold Mode. Then measurement is also conducted by Average Detector and Quasi-Peak Detector Function respectively.

### 3.1.4 Test Setup

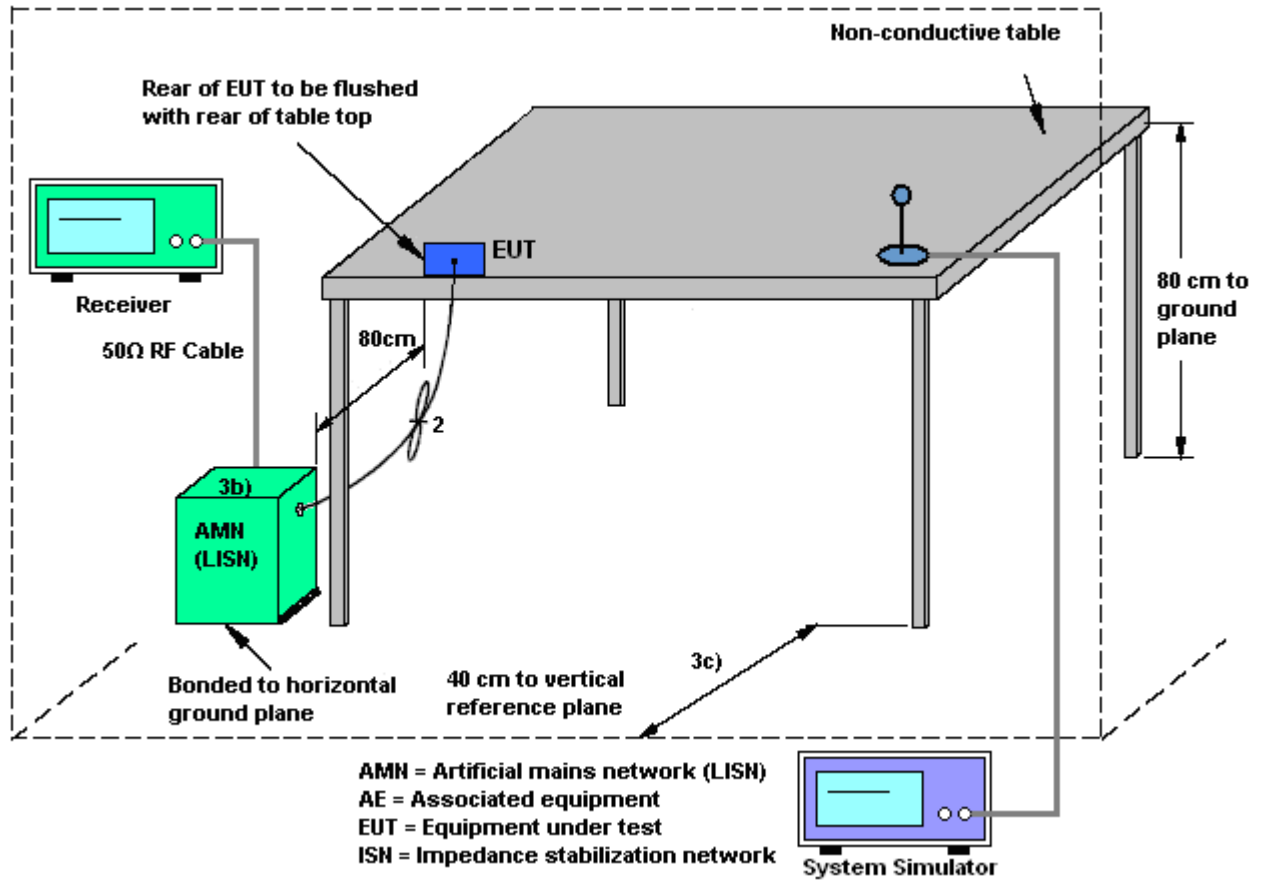



3.1.5 Test Result of AC Conducted Emission

Test Mode :	Mode 6	Temperature :	22~24°C
Test Engineer :	Amos Zhang	Relative Humidity :	42~45%
Test Voltage :	120Vac / 60Hz	Phase :	Line
Function Type :	LTE Band 17 Idle + Bluetooth Idle + WLAN (2.4G) Idle + USB Cable (Data Link with Notebook) + Earphone + Battery + GNSS Rx		

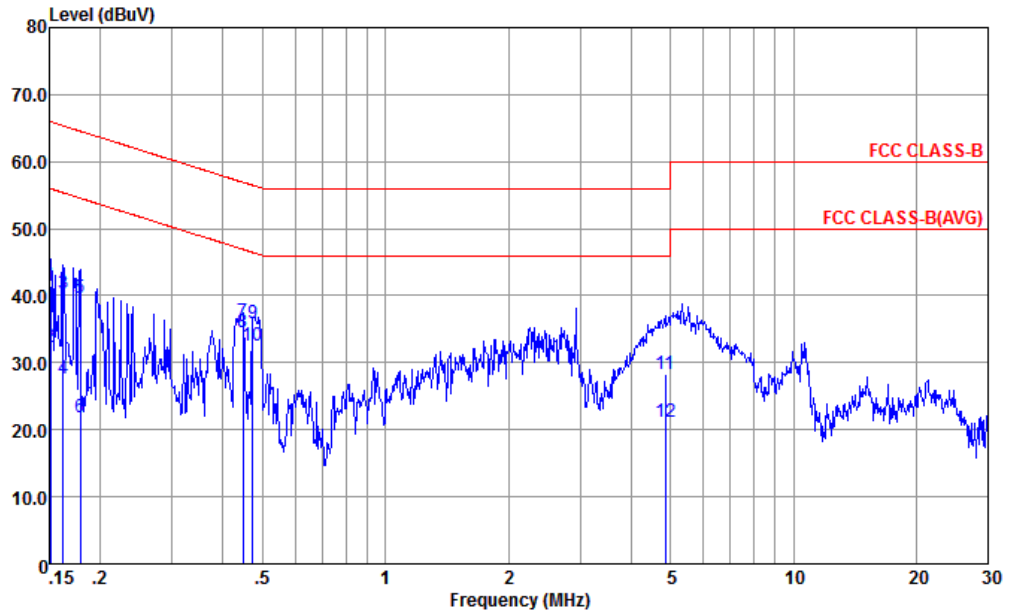

Site : CO01-KS  
 Condition : FCC CLASS-B LISN-L-171013-060103 LINE  
 Project : (FC) 7D2001-02

: 351840090011507 #1

	Freq	Level	Over Limit	Limit Line	Read Level	LISN Factor	Cable Loss	Remark
	MHz	dBuV	dB	dBuV	dBuV	dB	dB	
1	0.151	41.38	-24.58	65.96	30.60	0.16	10.62	QP
2	0.151	32.38	-23.58	55.96	21.60	0.16	10.62	Average
3	0.162	40.35	-24.99	65.34	29.61	0.17	10.57	QP
4	0.162	27.55	-27.79	55.34	16.81	0.17	10.57	Average
5	0.179	39.60	-24.95	64.55	28.90	0.18	10.52	QP
6	0.179	21.90	-32.65	54.55	11.20	0.18	10.52	Average
7	0.447	36.21	-20.72	56.93	25.60	0.25	10.36	QP
8 *	0.447	34.51	-12.42	46.93	23.90	0.25	10.36	Average
9	0.474	35.89	-20.56	56.45	25.30	0.26	10.33	QP
10	0.474	32.49	-13.96	46.45	21.90	0.26	10.33	Average
11	4.848	28.19	-27.81	56.00	17.60	0.37	10.22	QP
12	4.848	21.09	-24.91	46.00	10.50	0.37	10.22	Average



Test Mode :	Mode 6	Temperature :	22~24°C
Test Engineer :	Amos Zhang	Relative Humidity :	42~45%
Test Voltage :	120Vac / 60Hz	Phase :	Neutral
Function Type :	LTE Band 17 Idle + Bluetooth Idle + WLAN (2.4G) Idle + USB Cable (Data Link with Notebook) + Earphone + Battery + GNSS Rx		

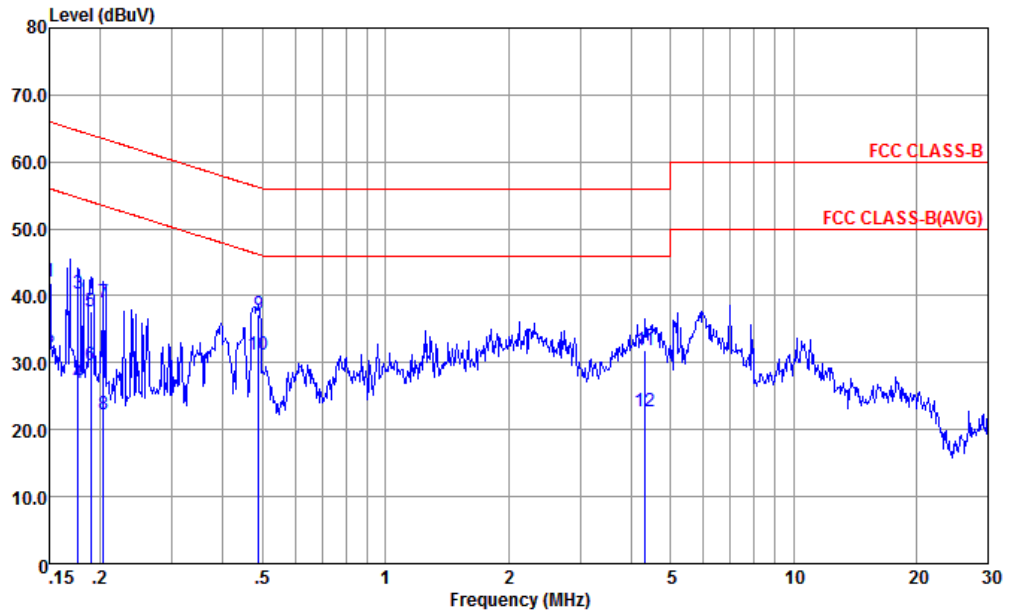

Site : CO01-KS  
 Condition : FCC CLASS-B LISN-N-171013-060103 NEUTRAL  
 Project : (FC) 7D2001-02

: 351840090011507 #1

	Freq	Level	Over Limit	Limit Line	Read Level	LISN Factor	Cable Loss	Remark
	MHz	dBuV	dB	dBuV	dBuV	dB	dB	
1	0.150	42.20	-23.80	66.00	31.30	0.28	10.62	QP
2	0.150	31.50	-24.50	56.00	20.60	0.28	10.62	Average
3	0.177	40.41	-24.23	64.64	29.60	0.28	10.53	QP
4	0.177	27.01	-27.63	54.64	16.20	0.28	10.53	Average
5	0.189	37.57	-26.49	64.06	26.80	0.28	10.49	QP
6	0.189	29.57	-24.49	54.06	18.80	0.28	10.49	Average
7	0.204	39.03	-24.42	63.45	28.30	0.28	10.45	QP
8	0.204	22.33	-31.12	53.45	11.60	0.28	10.45	Average
9	0.489	37.21	-18.98	56.19	26.60	0.29	10.32	QP
10 *	0.489	31.21	-14.98	46.19	20.60	0.29	10.32	Average
11	4.338	31.83	-24.17	56.00	21.30	0.34	10.19	QP
12	4.338	22.73	-23.27	46.00	12.20	0.34	10.19	Average



Test Mode :	Mode 5	Temperature :	22~24°C
Test Engineer :	Amos Zhang	Relative Humidity :	42~45%
Test Voltage :	120Vac / 60Hz	Phase :	Line
Function Type :	GSM850 Idle + Bluetooth Idle + WLAN (2.4G) Idle + USB Cable (Charging from Adapter 2) + Earphone + Battery + Camera (Rear)		

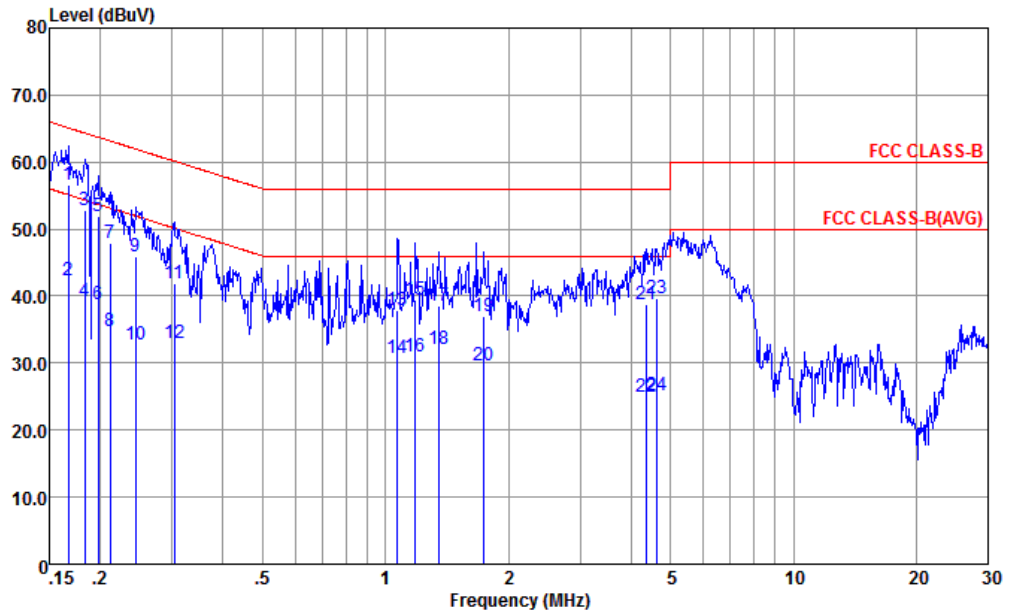

Site : CO01-KS  
 Condition : FCC CLASS-B LISN-L-171013-060103 LINE  
 Project : (FC) 7D2001-02

: 351840090011507 #1

	Freq	Level	Over Limit	Limit Line	Read Level	LISN Factor	Cable Loss	Remark
	MHz	dBuV	dB	dBuV	dBuV	dB	dB	
1 *	0.167	56.53	-8.59	65.12	45.80	0.17	10.56	QP
2	0.167	42.33	-12.79	55.12	31.60	0.17	10.56	Average
3	0.183	52.90	-11.43	64.33	42.20	0.19	10.51	QP
4	0.183	39.30	-15.03	54.33	28.60	0.19	10.51	Average
5	0.198	51.86	-11.85	63.71	41.20	0.20	10.46	QP
6	0.198	38.86	-14.85	53.71	28.20	0.20	10.46	Average
7	0.212	47.86	-15.28	63.14	37.21	0.20	10.45	QP
8	0.212	34.86	-18.28	53.14	24.21	0.20	10.45	Average
9	0.244	45.85	-16.10	61.95	35.20	0.21	10.44	QP
10	0.244	32.85	-19.10	51.95	22.20	0.21	10.44	Average
11	0.303	41.95	-18.20	60.15	31.29	0.23	10.43	QP
12	0.303	32.95	-17.20	50.15	22.29	0.23	10.43	Average
13	1.071	37.98	-18.02	56.00	27.60	0.26	10.12	QP
14	1.071	30.68	-15.32	46.00	20.30	0.26	10.12	Average
15	1.184	39.50	-16.50	56.00	29.11	0.26	10.13	QP
16	1.184	31.00	-15.00	46.00	20.61	0.26	10.13	Average
17	1.352	38.62	-17.38	56.00	28.20	0.27	10.15	QP



Test Mode :	Mode 5	Temperature :	22~24°C
Test Engineer :	Amos Zhang	Relative Humidity :	42~45%
Test Voltage :	120Vac / 60Hz	Phase :	Line
Function Type :	GSM850 Idle + Bluetooth Idle + WLAN (2.4G) Idle + USB Cable (Charging from Adapter 2) + Earphone + Battery + Camera (Rear)		

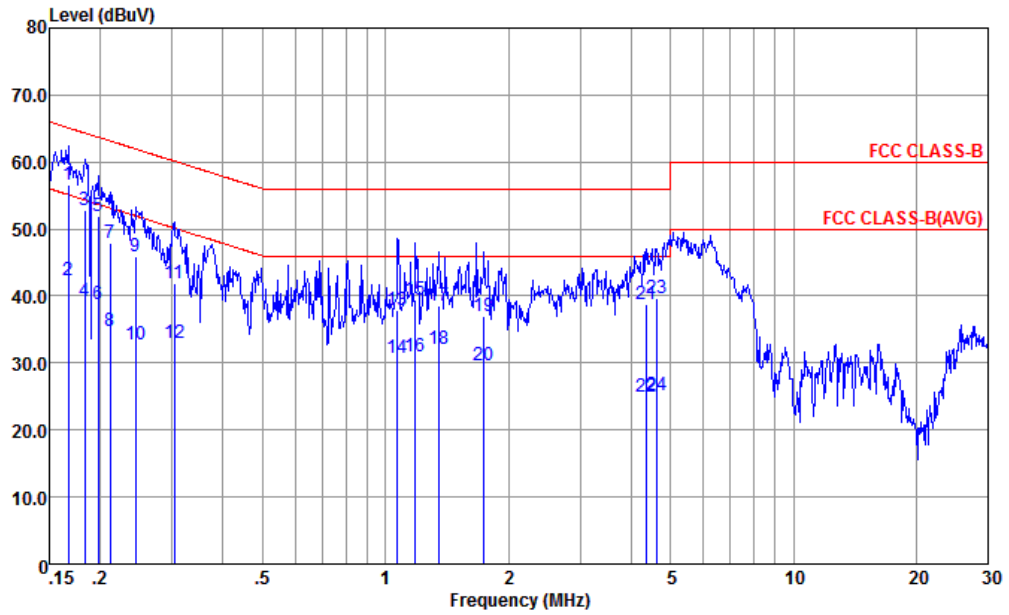

Site : CO01-KS  
 Condition : FCC CLASS-B LISN-L-171013-060103 LINE  
 Project : (FC) 7D2001-02

: 351840090011507 #1

	Freq	Level	Over Limit	Limit Line	Read Level	LISN Factor	Cable Loss	Remark
	MHz	dBuV	dB	dBuV	dBuV	dB	dB	
18	1.352	32.02	-13.98	46.00	21.60	0.27	10.15	Average
19	1.744	37.07	-18.93	56.00	26.60	0.28	10.19	QP
20	1.744	29.67	-16.33	46.00	19.20	0.28	10.19	Average
21	4.361	38.75	-17.25	56.00	28.20	0.36	10.19	QP
22	4.361	25.05	-20.95	46.00	14.50	0.36	10.19	Average
23	4.622	39.77	-16.23	56.00	29.20	0.36	10.21	QP
24	4.622	25.17	-20.83	46.00	14.60	0.36	10.21	Average



Test Mode :	Mode 5	Temperature :	22~24°C
Test Engineer :	Amos Zhang	Relative Humidity :	42~45%
Test Voltage :	120Vac / 60Hz	Phase :	Neutral
Function Type :	GSM850 Idle + Bluetooth Idle + WLAN (2.4G) Idle + USB Cable (Charging from Adapter 2) + Earphone + Battery + Camera (Rear)		

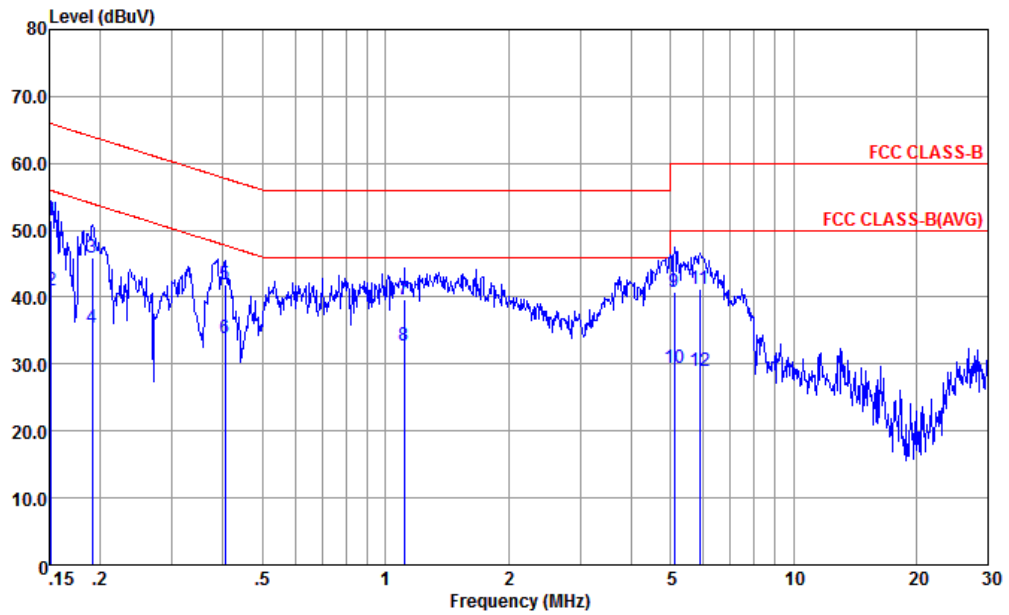

Site : CO01-KS  
 Condition : FCC CLASS-B LISN-N-171013-060103 NEUTRAL  
 Project : (FC) 7D2001-02

: 351840090011507 #1

	Freq	Level	Over Limit	Limit Line	Read Level	LISN Factor	Cable Loss	Remark
	MHz	dBuV	dB	dBuV	dBuV	dB	dB	
1	0.152	51.39	-14.52	65.91	40.50	0.28	10.61	QP
2	0.152	41.09	-14.82	55.91	30.20	0.28	10.61	Average
3	0.191	45.96	-18.02	63.98	35.20	0.28	10.48	QP
4	0.191	35.36	-18.62	53.98	24.60	0.28	10.48	Average
5	0.404	41.89	-15.88	57.77	31.20	0.29	10.40	QP
6	0.404	33.89	-13.88	47.77	23.20	0.29	10.40	Average
7	1.111	39.74	-16.26	56.00	29.31	0.31	10.12	QP
8 *	1.111	32.74	-13.26	46.00	22.31	0.31	10.12	Average
9	5.112	40.89	-19.11	60.00	30.30	0.34	10.25	QP
10	5.112	29.49	-20.51	50.00	18.90	0.34	10.25	Average
11	5.898	41.26	-18.74	60.00	30.60	0.33	10.33	QP
12	5.898	28.96	-21.04	50.00	18.30	0.33	10.33	Average



### 3.2. Test of Radiated Emission Measurement

#### 3.2.1. Limit of Radiated Emission

The emissions from an unintentional radiator shall not exceed the field strength levels specified in the following table:

Frequency (MHz)	Field Strength (microvolts/meter)	Measurement Distance (meters)
30 – 88	100	3
88 – 216	150	3
216 - 960	200	3
Above 960	500	3

#### 3.2.2. Measuring Instruments

The measuring equipment is listed in the section 4 of this test report.

#### 3.2.3. Test Procedures

1. The EUT was placed on a turntable with 0.8 meter above ground.
2. The EUT was set 3 meters from the interference receiving antenna, which was mounted on the top of a variable height antenna tower.
3. The table was rotated 360 degrees to determine the position of the highest radiation.
4. The antenna is a Bi-Log antenna and its height is adjusted between one to four meters above ground to find the maximum value of the field strength for both horizontal polarization and vertical polarization of the antenna.
5. For each suspected emission, the EUT was arranged to its worst case and then tune the antenna tower (from 1 m to 4 m) and turntable (from 0 degree to 360 degrees) to find the maximum reading.
6. Set the test-receiver system to Peak Detect Function and specified bandwidth with Maximum Hold Mode (RBW=120kHz/VBW=300kHz for frequency below 1GHz; RBW=1MHz VBW=3MHz (Peak), RBW=1MHz/VBW=10Hz (Average) for frequency above 1GHz).
7. If the emission level of the EUT in peak mode was 3 dB lower than the limit specified, peak values of EUT will be reported. Otherwise, the emission will be repeated by using the quasi-peak method and reported.
8. Emission level (dBµV/m) = 20 log Emission level (µV/m)
9. Corrected Reading: Antenna Factor + Cable Loss + Read Level - Preamp Factor = Level

### 3.2.4. Test Setup of Radiated Emission

For radiated emissions from 30MHz to 1GHz

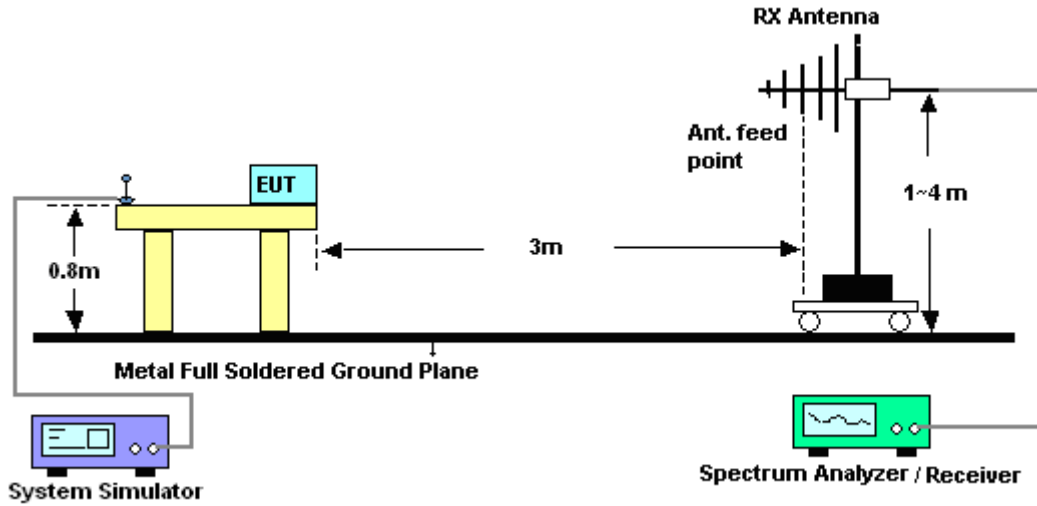

For radiated emissions above 1GHz

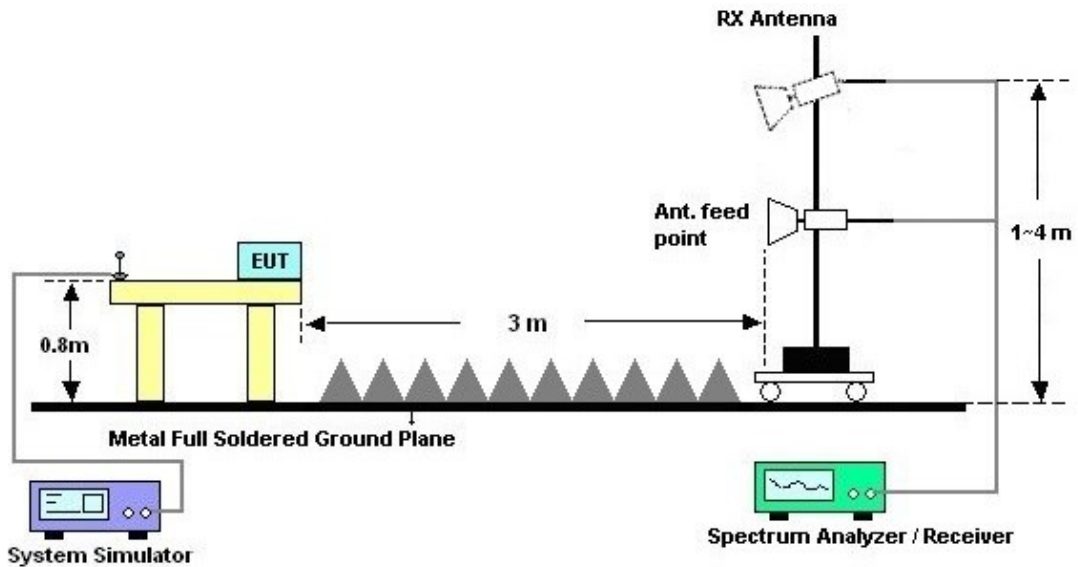



3.2.5. Test Result of Radiated Emission

Test Mode :	Mode 6	Temperature :	21~22°C
Test Engineer :	Leo Liao	Relative Humidity :	41~42%
Test Distance :	3m	Polarization :	Horizontal
Function Type :	LTE Band 17 Idle + Bluetooth Idle + WLAN (5G) Idle + USB Cable (Data Link with Notebook) + Earphone + Battery + GNSS Rx		
Remark :	#6 is system simulator signal which can be ignored.		

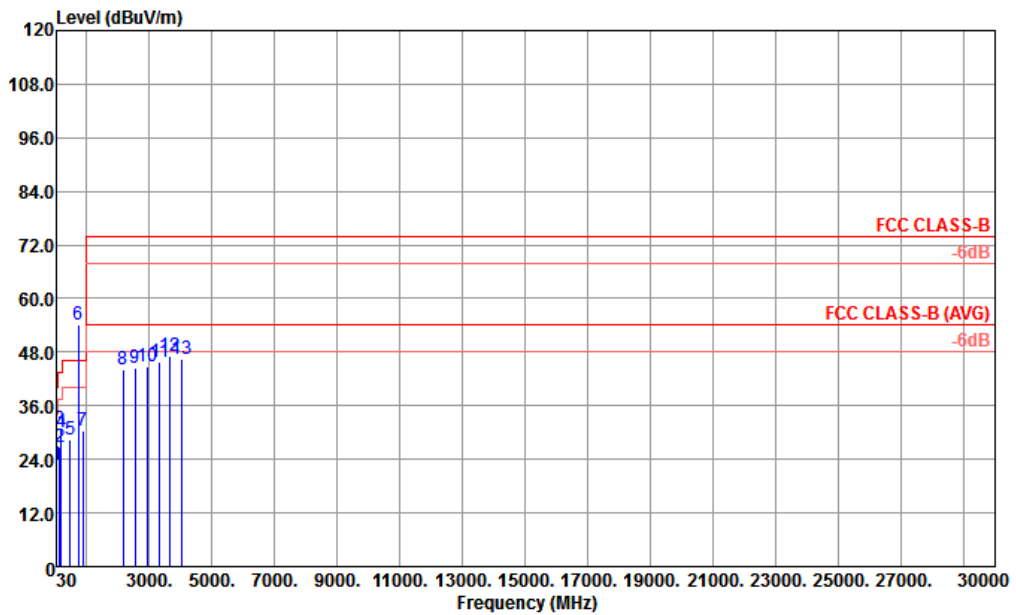

Site : 03CH02-KS  
 Condition : FCC CLASS-B 3m 02 LF ANT HORIZONTAL  
 Project : (FC)7D2001-02  
 IMEI : 351840090009832 #2

	Freq	Level	Over Limit	Limit Line	ReadAntenna Level	Antenna Factor	Cable Loss	Preamp Factor	A/Pos	T/Pos	Remark
	MHz	dBuV/m	dB	dBuV/m	dBuV	dB/m	dB	dB	cm	deg	
1	30.27	22.63	-17.37	40.00	28.49	25.60	0.57	32.03	---	---	Peak
2	144.48	26.65	-16.85	43.50	39.72	17.55	1.23	31.85	---	---	Peak
3	165.54	30.89	-12.61	43.50	44.40	16.96	1.32	31.79	100	---	Peak
4	194.43	30.06	-13.44	43.50	44.33	16.00	1.42	31.69	---	---	Peak
5	479.90	28.34	-17.66	46.00	32.82	23.62	2.30	30.40	---	---	Peak
6 *	738.20	54.15			53.43	26.63	2.80	28.71	---	---	Peak
7	885.90	30.42	-15.58	46.00	27.59	27.38	3.08	27.63	---	---	Peak
8	2172.00	44.13	-29.87	74.00	41.59	30.88	4.90	33.24	---	---	Peak
9	2534.00	44.32	-29.68	74.00	40.22	31.53	5.29	32.72	---	---	Peak
10	2934.00	44.65	-29.35	74.00	38.19	32.40	5.92	31.86	---	---	Peak
11	3333.00	45.87	-28.13	74.00	38.49	33.28	6.25	32.15	---	---	Peak
12	3633.00	47.04	-26.96	74.00	38.72	33.92	6.49	32.09	---	---	Peak
13	4026.00	46.52	-27.48	74.00	37.02	35.15	6.79	32.44	---	---	Peak



Test Mode :	Mode 6	Temperature :	21~22°C
Test Engineer :	Leo Liao	Relative Humidity :	41~42%
Test Distance :	3m	Polarization :	Vertical
Function Type :	LTE Band 17 Idle + Bluetooth Idle + WLAN (5G) Idle + USB Cable (Data Link with Notebook) + Earphone + Battery + GNSS Rx		
Remark :	#6 is system simulator signal which can be ignored.		

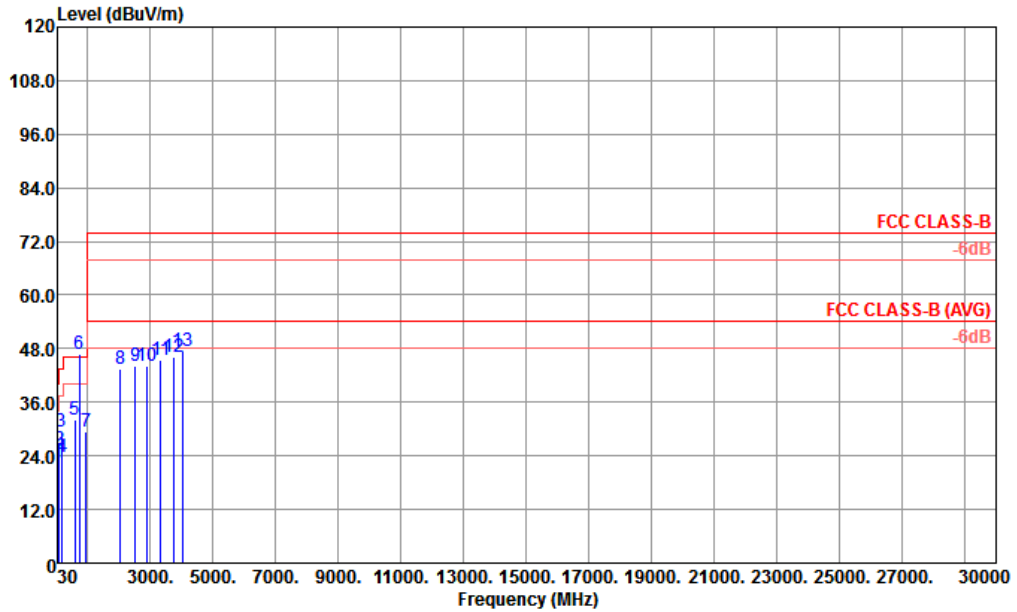

Site : 03CH02-KS  
 Condition : FCC CLASS-B 3m 02 LF ANT VERTICAL  
 Project : (FC)7D2001-02  
 IMEI : 351840090009832 #2

	Freq	Level	Over Limit	Limit Line	ReadAntenna Level	Antenna Factor	Cable Loss	Preamp Factor	A/Pos	T/Pos	Remark
	MHz	dBUV/m	dB	dBUV/m	dBuV	dB/m	dB	dB	cm	deg	
1	30.27	22.26	-17.74	40.00	28.12	25.60	0.57	32.03	---	---	Peak
2	88.86	25.25	-18.25	43.50	39.51	16.80	0.97	32.03	---	---	Peak
3	165.81	29.45	-14.05	43.50	42.96	16.96	1.32	31.79	---	---	Peak
4	194.70	23.59	-19.91	43.50	37.91	15.94	1.43	31.69	---	---	Peak
5	596.80	32.00	-14.00	46.00	34.46	24.60	2.62	29.68	100	0	Peak
6 *	735.40	46.96			46.26	26.62	2.80	28.72	---	---	Peak
7	947.50	29.47	-16.53	46.00	24.96	28.46	3.20	27.15	---	---	Peak
8	2050.00	43.61	-30.39	74.00	41.46	30.47	4.71	33.03	---	---	Peak
9	2526.00	44.06	-29.94	74.00	38.02	31.53	5.29	30.78	---	---	Peak
10	2902.00	44.16	-29.84	74.00	35.93	32.30	5.90	29.97	---	---	Peak
11	3318.00	45.44	-28.56	74.00	38.08	33.26	6.25	32.15	---	---	Peak
12	3762.00	46.09	-27.91	74.00	37.00	34.70	6.59	32.20	---	---	Peak
13	4029.00	47.42	-26.58	74.00	37.92	35.15	6.79	32.44	---	---	Peak



Test Mode :	Mode 10	Temperature :	21~22°C
Test Engineer :	Leo Liao	Relative Humidity :	41~42%
Test Distance :	3m	Polarization :	Horizontal
Function Type :	USB Cable (Charging from Adapter 2) + FM Rx (98MHz) + Earphone + Battery		
Remark :	#4 is system simulator (FM Option) signal which can be ignored.		

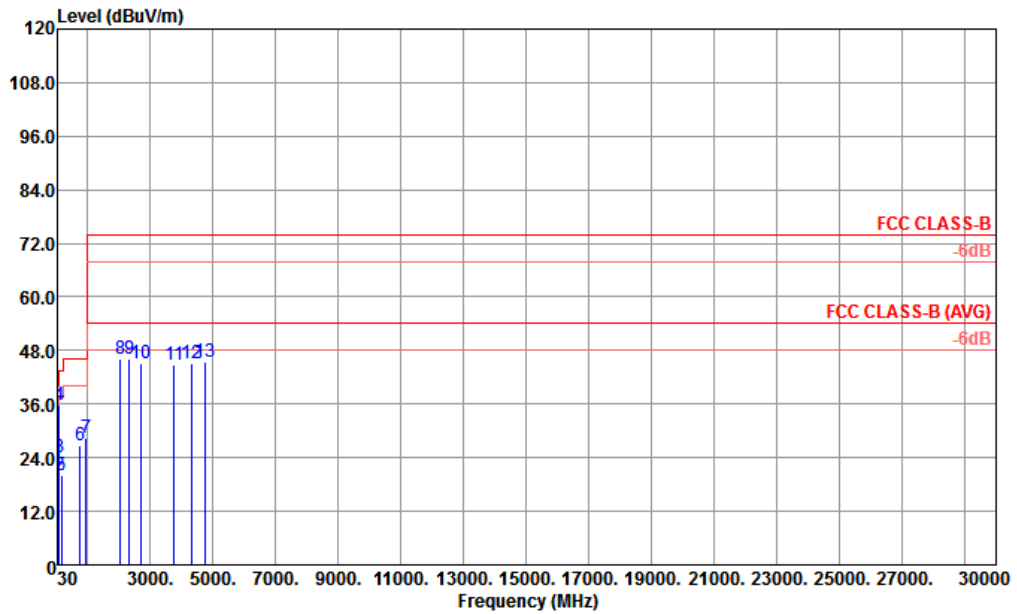

Site : 03CH02-KS  
 Condition : FCC CLASS-B 3m 02 LF ANT HORIZONTAL  
 Project : (FC)7D2001-02

IMEI : 351840090009832 #2

	Freq	Level	Over Limit	Limit Line	ReadAntenna Level	Antenna Factor	Cable Loss	Preamp Factor	A/Pos	T/Pos	Remark
	MHz	dBuV/m	dB	dBuV/m	dBuV	dB/m	dB	dB	cm	deg	
1	32.43	22.87	-17.13	40.00	29.07	25.23	0.61	32.04	100	0	Peak
2	79.14	19.99	-20.01	40.00	36.23	14.90	0.91	32.05	---	---	Peak
3	94.80	23.92	-19.58	43.50	37.64	17.30	0.98	32.00	---	---	Peak
4	98.04	35.79			49.05	17.70	1.00	31.96	---	---	Peak
5	149.61	19.91	-23.59	43.50	33.00	17.50	1.25	31.84	---	---	Peak
6	746.60	26.59	-19.41	46.00	25.75	26.69	2.82	28.67	---	---	Peak
7	955.20	28.29	-17.71	46.00	23.57	28.62	3.21	27.11	---	---	Peak
8	2034.00	46.05	-27.95	74.00	43.85	30.42	4.67	32.89	---	---	Peak
9	2326.00	46.01	-27.99	74.00	41.65	31.19	5.07	31.90	---	---	Peak
10	2698.00	45.15	-28.85	74.00	38.14	31.82	5.60	30.41	---	---	Peak
11	3765.00	44.93	-29.07	74.00	33.73	34.73	6.59	30.12	---	---	Peak
12	4329.00	45.23	-28.77	74.00	33.60	35.64	7.19	31.20	---	---	Peak
13	4764.00	45.43	-28.57	74.00	34.67	35.70	7.69	32.63	---	---	Peak



Test Mode :	Mode 10	Temperature :	21~22°C
Test Engineer :	Leo Liao	Relative Humidity :	41~42%
Test Distance :	3m	Polarization :	Vertical
Function Type :	USB Cable (Charging from Adapter 2) + FM Rx (98MHz) + Earphone + Battery		
Remark :	#5 is system simulator (FM Option) signal which can be ignored.		

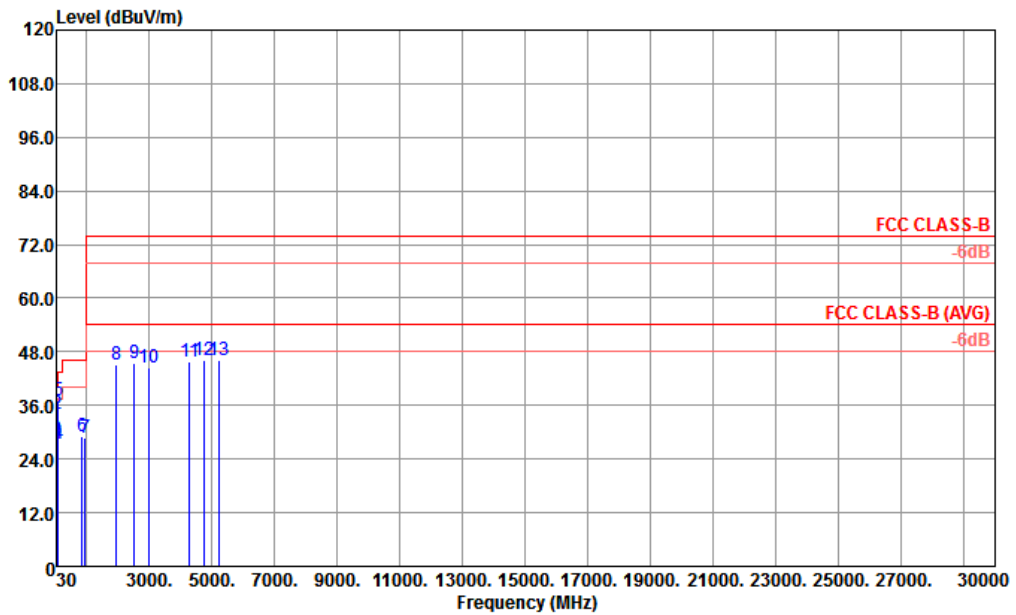

Site : 03CH02-KS  
 Condition : FCC CLASS-B 3m 02 LF ANT VERTICAL  
 Project : (FC)7D2001-02

IMEI : 351840090009832 #2

	Freq	Level	Over Limit	Limit Line	ReadAntenna Level	Cable Factor	Preamp Loss	A/Pos	T/Pos	Remark	
	MHz	dBuV/m	dB	dBuV/m	dBuV	dB/m	dB	dB	cm	deg	
1	31.35	28.33	-11.67	40.00	34.53	25.23	0.60	32.03	---	---	Peak
2	42.96	34.04	-5.96	40.00	44.90	20.57	0.65	32.08	100	0	Peak
3	52.41	28.33	-11.67	40.00	44.59	15.10	0.74	32.10	---	---	Peak
4	82.65	27.42	-12.58	40.00	43.10	15.43	0.94	32.05	---	---	Peak
5	98.04	37.24			50.50	17.70	1.00	31.96	---	---	Peak
6	859.30	29.20	-16.80	46.00	26.80	27.18	3.06	27.84	---	---	Peak
7	956.60	28.82	-17.18	46.00	24.09	28.62	3.21	27.10	---	---	Peak
8	1956.00	44.97	-29.03	74.00	43.48	29.96	4.59	33.06	---	---	Peak
9	2508.00	45.33	-28.67	74.00	39.14	31.50	5.26	30.57	---	---	Peak
10	2964.00	44.42	-29.58	74.00	35.02	32.50	5.94	29.04	---	---	Peak
11	4272.00	45.71	-28.29	74.00	34.02	35.53	7.25	31.09	---	---	Peak
12	4770.00	46.20	-27.80	74.00	35.45	35.69	7.69	32.63	---	---	Peak
13	5208.00	46.16	-27.84	74.00	37.35	35.34	7.74	34.27	---	---	Peak



### 4. List of Measuring Equipment

Instrument	Manufacturer	Model No.	Serial No.	Characteristics	Calibration Date	Test Date	Due Date	Remark
EMI Receiver	R&S	ESCI7	100768	9kHz~7GHz;	Apr. 20, 2017	Jan. 02, 2018	Apr. 19, 2018	Conduction (CO01-KS)
AC LISN	MessTec	AN3016	060103	9kHz~30MHz	Oct. 13, 2017	Jan. 02, 2018	Oct. 12, 2018	Conduction (CO01-KS)
AC LISN (for auxiliary equipment)	MessTec	AN3016	060105	9kHz~30MHz	Oct. 13, 2017	Jan. 02, 2018	Oct. 12, 2018	Conduction (CO01-KS)
AC Power Source	Chroma	61602	ABP0000008 11	AC 0V~300V, 45Hz~1000Hz	Oct. 12, 2017	Jan. 02, 2018	Oct. 11, 2018	Conduction (CO01-KS)
EMI Test Receiver	R&S	ESR7	101403	9kHz~7GHz; Max 30dBm	Aug. 08, 2017	Jan. 06, 2018~ Jan. 08, 2018	Aug. 07, 2018	Radiation (03CH02-KS)
EXA Spectrum Analyzer	Keysight	N9010A	MY55150208	10Hz~44GHz, MAX 30dB	Apr. 18, 2017	Jan. 06, 2018~ Jan. 08, 2018	Apr. 17, 2018	Radiation (03CH02-KS)
Bilog Antenna	TeseQ	CBL6112D	23182	30MHz~2GHz	Jan. 22, 2017	Jan. 06, 2018~ Jan. 08, 2018	Jan. 21, 2018	Radiation (03CH02-KS)
Double Ridge Horn Antenna	ETS-Lindgren	3117	75957	1GHz~18GHz	Oct. 21, 2017	Jan. 06, 2018~ Jan. 08, 2018	Oct. 20, 2018	Radiation (03CH02-KS)
SHF-EHF Horn	Schwarzbeck	BBHA 9170	BBHA170249	15GHz~40GHz	Feb. 15, 2017	Jan. 06, 2018~ Jan. 08, 2018	Feb. 14, 2018	Radiation (03CH02-KS)
Amplifier	MITEQ	TTA1840-35-H G	1887435	18GHz~40GHz	Oct. 12, 2017	Jan. 06, 2018~ Jan. 08, 2018	Oct. 11, 2018	Radiation (03CH02-KS)
Amplifier	SONOMA	310N	187289	9kHz~1GHz	Aug. 07, 2017	Jan. 06, 2018~ Jan. 08, 2018	Aug. 06, 2018	Radiation (03CH02-KS)
Amplifier	Agilent	8449B	3008A02384	1-26.5GHz Gain 30dB	Oct. 12, 2017	Jan. 06, 2018~ Jan. 08, 2018	Oct. 11, 2018	Radiation (03CH02-KS)
AC Power Source	Chroma	61601	61601000247 3	N/A	NCR	Jan. 06, 2018~ Jan. 08, 2018	NCR	Radiation (03CH02-KS)
Turn Table	MF	MF7802	N/A	0~360 degree	NCR	Jan. 06, 2018~ Jan. 08, 2018	NCR	Radiation (03CH02-KS)
Antenna Mast	MF	MF7802	N/A	1 m~4 m	NCR	Jan. 06, 2018~ Jan. 08, 2018	NCR	Radiation (03CH02-KS)

NCR: No Calibration Required



## 5. Uncertainty of Evaluation

### Uncertainty of Conducted Emission Measurement (150 kHz ~ 30 MHz)

Measuring Uncertainty for a Level of Confidence of 95% ( $U = 2Uc(y)$ )	2.3dB
---	-------

### Uncertainty of Radiated Emission Measurement (30 MHz ~ 1000 MHz)

Measuring Uncertainty for a Level of Confidence of 95% ( $U = 2Uc(y)$ )	5.2dB
---	-------

### Uncertainty of Radiated Emission Measurement (1GHz ~ 18GHz)

Measuring Uncertainty for a Level of Confidence of 95% ( $U = 2Uc(y)$ )	4.7dB
---	-------

### Uncertainty of Radiated Emission Measurement (18GHz ~ 40GHz)

Measuring Uncertainty for a Level of Confidence of 95% ( $U = 2Uc(y)$ )	5.3dB
---	-------