



FCC Test Report

APPLICANT : Motorola Mobility LLC
EQUIPMENT : Mobile Cellular Phone
BRAND NAME : Motorola
MODEL NAME : XT1926-5
FCC ID : IHDT56WL3
STANDARD : FCC 47 CFR FCC Part 15 Subpart B
CLASSIFICATION : Certification

The product was received on Dec. 28, 2017 and testing was completed on Feb. 09, 2018. We, Sporton International (KunShan) Inc., would like to declare that the tested sample has been evaluated in accordance with the test procedures given in ANSI C63.4-2014 and has been in compliance with the applicable technical standards.

The test results in this report apply exclusively to the tested model / sample. Without written approval of Sporton International (KunShan) Inc., the test report shall not be reproduced except in full.



Approved by: James Huang / Manager

Sporton International (Kunshan) Inc.

No.3-2 Ping-Xiang Rd, Kunshan Development Zone Kunshan City Jiangsu Province 215335 China



TABLE OF CONTENTS

REVISION HISTORY..... 3

SUMMARY OF TEST RESULT 4

1. GENERAL DESCRIPTION 5

 1.1. Applicant..... 5

 1.2. Manufacturer 5

 1.3. Product Feature of Equipment Under Test 5

 1.4. Product Specification of Equipment Under Test 6

 1.5. Modification of EUT 7

 1.6. Specification of Accessory 8

 1.7. Test Location 9

 1.8. Applicable Standards 9

2. TEST CONFIGURATION OF EQUIPMENT UNDER TEST 10

 2.1. Test Mode 10

 2.2. Connection Diagram of Test System 12

 2.3. Support Unit used in test configuration and system 14

 2.4. EUT Operation Test Setup 15

3. TEST RESULT 16

 3.1. Test of AC Conducted Emission Measurement 16

 3.2. Test of Radiated Emission Measurement 22

4. LIST OF MEASURING EQUIPMENT 28

5. UNCERTAINTY OF EVALUATION 29

APPENDIX A. SETUP PHOTOGRAPHS



REVISION HISTORY

REPORT NO.	VERSION	DESCRIPTION	ISSUED DATE
FC7D2702-05	Rev. 01	Initial issue of report	Mar. 12, 2018



SUMMARY OF TEST RESULT

Report Section	FCC Rule	Description	Limit	Result	Remark
3.1	15.107	AC Conducted Emission	< 15.107 limits	PASS	Under limit 7.67 dB at 0.228 MHz
3.2	15.109	Radiated Emission	< 15.109 limits	PASS	Under limit 4.65 dB at 44.850 MHz for Quasi-Peak



1. General Description

1.1. Applicant

Motorola Mobility LLC
222 W,Merchandise Mart Plaza, Chicago IL 60654 USA

1.2. Manufacturer

Motorola Mobility LLC
222 W,Merchandise Mart Plaza, Chicago IL 60654 USA

1.3. Product Feature of Equipment Under Test

Product Feature	
Equipment	Mobile Cellular Phone
Brand Name	Motorola
Model Name	XT1926-5
FCC ID	IHDT56WL3
EUT supports Radios application	GSM/GPRS/EGPRS/WCDMA/HSPA/ DC-HSDPA/ HSPA+(16QAM uplink is not supported)/LTE/NFC WLAN 2.4GHz 802.11b/g/n HT20 WLAN 5GHz 802.11a/n HT20/HT40 WLAN 5GHz 802.11ac VHT20/VHT40/VHT80 Bluetooth v3.0+ EDR / Bluetooth v4.0 LE/ Bluetooth v4.1 LE / Bluetooth v4.2 LE / Bluetooth v5.0 LE
IMEI Code	Conduction: 351855090018278/351855090018286 Radiation: 351855090018294/351855090018302
HW Version	DVT1B
SW Version	evert_n-userdebug 8.0.0 OPW27.88 1825 intcfg,test-keys
EUT Stage	Identical Prototype

Remark: The above EUT's information was declared by manufacturer. Please refer to the specifications or user's manual for more detailed description.



1.4. Product Specification of Equipment Under Test

Standards-related Product Specification	
Tx Frequency	GSM850: 824.2 MHz ~ 848.8 MHz GSM1900: 1850.2 MHz ~ 1909.8MHz WCDMA Band V: 826.4 MHz ~ 846.6 MHz WCDMA Band II: 1852.4 MHz ~ 1907.6 MHz LTE Band 2 : 1850.7 MHz ~ 1909.3 MHz LTE Band 5 : 824.7 MHz ~ 848.3 MHz LTE Band 7 : 2502.5 MHz ~ 2567.5 MHz LTE Band 26 : 814.7 MHz ~ 848.3 MHz LTE Band 38 : 2572.5 MHz ~ 2617.5 MHz 802.11b/g/n: 2412 MHz ~ 2462 MHz 802.11a/n/ac: 5180 MHz ~ 5240 MHz; 5260 MHz ~ 5320 MHz; 5500 MHz ~ 5700 MHz; 5745 MHz ~ 5825 MHz; Bluetooth: 2402 MHz ~ 2480 MHz NFC : 13.56 MHz
Rx Frequency	GSM850: 869.2 MHz ~ 893.8 MHz GSM1900: 1930.2 MHz ~ 1989.8 MHz WCDMA Band V: 871.4 MHz ~ 891.6 MHz WCDMA Band II: 1932.4 MHz ~ 1987.6 MHz LTE Band 2 : 1930.7 MHz ~ 1989.3 MHz LTE Band 5 : 869.7 MHz ~ 893.3 MHz LTE Band 7 : 2622.5 MHz ~ 2687.5 MHz LTE Band 26 : 859.7 MHz ~ 893.3 MHz LTE Band 38 : 2572.5 MHz ~ 2617.5 MHz 802.11b/g/n: 2412 MHz ~ 2462 MHz 802.11a/n/ac: 5180 MHz ~ 5240 MHz; 5260 MHz ~ 5320 MHz; 5500 MHz ~ 5700 MHz; 5745 MHz ~ 5825 MHz; Bluetooth: 2402 MHz ~ 2480 MHz GNSS : 1559 MHz ~ 1610 MHz FM : 88 MHz ~ 108 MHz NFC : 13.56 MHz
Antenna Type	WWAN : PIFA Antenna WLAN : PIFA Antenna Bluetooth : PIFA Antenna GNSS: PIFA Antenna NFC: Loop Antenna FM: External headset Antenna



Type of Modulation	GSM: GMSK GPRS: GMSK EDGE(MCS 0-4): GMSK / (MCS 5-9): 8PSK WCDMA : BPSK (Uplink) HSDPA/DC-HSDPA : QPSK (Uplink) HSUPA : QPSK (Uplink) HSPA+ : 16QAM (uplink is not supported) DC-HSDPA : 64QAM LTE: QPSK / 16QAM / 64QAM 802.11b : DSSS (DBPSK / DQPSK / CCK) 802.11a/g/n/ac : OFDM (BPSK / QPSK / 16QAM / 64QAM / 256QAM) Bluetooth LE : GFSK Bluetooth (1Mbps) : GFSK Bluetooth (2Mbps) : $\pi/4$ -DQPSK Bluetooth (3Mbps) : 8-DPSK GNSS : BPSK NFC : ASK FM
---------------------------	---

Note: GNSS Rx = GPS Rx + Glonass Rx

1.5. Modification of EUT

No modifications are made to the EUT during all test items.



1.6. Specification of Accessory

Specification of Accessory			
AC Adapter 1(US)	Brand Name	Motorola (Salom)	Model Name SC-22
	Power Rating	I/P: 100-240 Vac, 500mA, O/P: 5Vdc,3000mA or 9Vdc,1600mA or 12Vdc,1200mA	
AC Adapter 1(EU)	Brand Name	Motorola (Salom)	Model Name SC-23
	Power Rating	I/P: 100-240 Vac, 500mA, O/P: 5Vdc,3000mA or 9Vdc,1600mA or 12Vdc,1200mA	
AC Adapter 1(UK)	Brand Name	Motorola (Salom)	Model Name SC-24
	Power Rating	I/P: 100-240 Vac, 500mA, O/P: 5Vdc,3000mA or 9Vdc,1600mA or 12Vdc,1200mA	
AC Adapter 1(IN)	Brand Name	Motorola (Salom)	Model Name SC-25
	Power Rating	I/P: 100-240 Vac, 500mA, O/P: 5Vdc,3000mA or 9Vdc,1600mA or 12Vdc,1200mA	
AC Adapter 1(AU)	Brand Name	Motorola (Salom)	Model Name SC-26
	Power Rating	I/P: 100-240 Vac, 500mA, O/P: 5Vdc,3000mA or 9Vdc,1600mA or 12Vdc,1200mA	
AC Adapter 1 (Indonesia Local)	Brand Name	Motorola (Salom)	Model Name SC-23
	Power Rating	I/P: 100-240 Vac, 500mA, O/P: 5Vdc,3000mA or 9Vdc,1600mA or 12Vdc,1200mA	
AC Adapter 2(US)	Brand Name	Motorola (Chenyang)	Model Name SC-22
	Power Rating	I/P: 100-240 Vac, 500mA, O/P: 5Vdc,3000mA or 9Vdc,1600mA or 12Vdc,1200mA	
AC Adapter 2(EU)	Brand Name	Motorola (Chenyang)	Model Name SC-23
	Power Rating	I/P: 100-240 Vac, 500mA, O/P: 5Vdc,3000mA or 9Vdc,1600mA or 12Vdc,1200mA	
AC Adapter 2(UK)	Brand Name	Motorola (Chenyang)	Model Name SC-24
	Power Rating	I/P: 100-240 Vac, 500mA, O/P: 5Vdc,3000mA or 9Vdc,1600mA or 12Vdc,1200mA	
AC Adapter 2(IN)	Brand Name	Motorola (Chenyang)	Model Name SC-25
	Power Rating	I/P: 100-240 Vac, 500mA, O/P: 5Vdc,3000mA or 9Vdc,1600mA or 12Vdc,1200mA	
AC Adapter 2(AU)	Brand Name	Motorola (Chenyang)	Model Name SC-26
	Power Rating	I/P: 100-240 Vac, 500mA, O/P: 5Vdc,3000mA or 9Vdc,1600mA or 12Vdc,1200mA	
Battery	Brand Name	Motorola (ATL)	Model Name JT40
	Power Rating	3.8Vdc,3200mAh	Type Li-ion Polymer
Earphone 1	Brand Name	Motorola (Jiahe)	Model Name LS-118M-12
	Signal Line Type	1.2 meter, non-shielded cable, without ferrite core	
Earphone 2	Brand Name	Motorola (Lianyun)	Model Name TS910A-38AMS01WHR-M
	Signal Line Type	1.2 meter, non-shielded cable, without ferrite core	
USB Cable	Brand Name	Motorola (Liqi)	Model Name L32B-053000100-ALL
	Signal Line Type	1.0 meter, shielded cable, without ferrite core	



1.7. Test Location

Sporton International (Kunshan) Inc. is accredited to ISO 17025 by National Voluntary Laboratory Accreditation Program (NVLAP code: 600155-0) and the FCC designation No. is CN5013.

Test Site	Sporton International (Kunshan) Inc.		
Test Site Location	No.3-2 Ping-Xiang Rd, Kunshan Development Zone Kunshan City Jiangsu Province 215335 China TEL : +86-512-57900158 FAX : +86-512-57900958		
Test Site No.	Sporton Site No.		FCC Test Firm Registration No.
	CO01-KS	03CH02-KS	630927

Note: The test site complies with ANSI C63.4 2014 requirement.

1.8. Applicable Standards

According to the specifications of the manufacturer, the EUT must comply with the requirements of the following standards:

- ♦ FCC 47 CFR FCC Part 15 Subpart B
- ♦ ANSI C63.4-2014

Remark: All test items were verified and recorded according to the standards and without any deviation during the test.



2. Test Configuration of Equipment Under Test

2.1. Test Mode

The EUT has been associated with peripherals pursuant to ANSI C63.4-2014 and configuration operated in a manner tended to maximize its emission characteristics in a typical application.

Frequency range investigated: conduction (150 kHz to 30 MHz), radiation (30MHz to the 5th harmonic of the highest fundamental frequency or to 40 GHz, whichever is lower).

Test Items	Function Type
AC Conducted Emission	Mode 1 : GSM 850 Idle + Bluetooth Idle + WLAN Idle (2.4G) + USB Cable (Charging from Adapter1) + Earphone 1 + Battery + Camera (Rear) + SIM 1<fig.1>
	Mode 2 : PCS 1900 Idle + Bluetooth Idle + WLAN Idle (2.4G) + USB Cable (Charging from Adapter1) + Earphone 1 + Battery + Camera (Front) + SIM 2<fig.1>
	Mode 3 : WCDMA Band V Idle + Bluetooth Idle + WLAN Idle (2.4G) + USB Cable (Charging from Adapter1) + Earphone 1 + Battery + MPEG4 + SIM 1<fig.1>
	Mode 4 : WCDMA Band II Idle + Bluetooth Idle + WLAN Idle (2.4G) + USB Cable (Charging from Adapter1) + Earphone 1 + Battery + GNSS Rx + SIM 2 <fig.2>
	Mode 5 : WCDMA Band II Idle + Bluetooth Idle + WLAN Idle (2.4G) + USB Cable (Charging from Adapter1) + Earphone 1 + Battery + NFC On + SIM 2<fig.1>
	Mode 6 : GSM 850 Idle + Bluetooth Idle + WLAN Idle (2.4G) + USB Cable (Charging from Adapter2) + Earphone 2 + Battery + Camera (Rear) + SIM 1<fig.1>
	Mode 7 : LTE Band 7 Idle + Bluetooth Idle + WLAN Idle (2.4G) + USB Cable (Data Link with Notebook) + Earphone 1 + Battery + GNSS Rx + SIM 1<fig.3>
	Mode 8 : USB Cable (Charging from Adapter 1) + Earphone 1 + Battery + FM Rx (88MHz)<fig.4>
	Mode 9 : USB Cable (Charging from Adapter 1) + Earphone 1 + Battery + FM Rx (98MHz)<fig.4>
	Mode 10 : USB Cable (Charging from Adapter 1) + Earphone 1 + Battery + FM Rx (108MHz)<fig.4>
	Mode 11 : USB Cable (Charging from Adapter 2) + Earphone 2 + Battery + FM Rx (88MHz)<fig.4>



Radiated Emissions< 1GHz	<p>Mode 1 : GSM 850 Idle + Bluetooth Idle + WLAN Idle (2.4G) + USB Cable (Charging from Adapter1) + Earphone 1 + Battery + Camera (Rear)<fig.1></p> <p>Mode 2 : PCS 1900 Idle + Bluetooth Idle + WLAN Idle (2.4G) + USB Cable (Charging from Adapter1) + Earphone 1 + Battery + Camera (Front)<fig.1></p> <p>Mode 3 : WCDMA Band V Idle + Bluetooth Idle + WLAN Idle (2.4G) + USB Cable (Charging from Adapter1) + Earphone 1 + Battery + MPEG4<fig.1></p> <p>Mode 4 : WCDMA Band II Idle + Bluetooth Idle + WLAN Idle (2.4G) + USB Cable (Charging from Adapter1) + Earphone 1 + Battery + GNSS Rx<fig.2></p> <p>Mode 5 : WCDMA Band II Idle + Bluetooth Idle + WLAN Idle (2.4G) + USB Cable (Charging from Adapter1) + Earphone 1 + Battery + NFC On<fig.1></p> <p>Mode 6 : WCDMA Band II Idle + Bluetooth Idle + WLAN Idle (2.4G) + USB Cable (Charging from Adapter2) + Earphone 2 + Battery + GNSS Rx<fig.1></p> <p>Mode 7 : LTE Band 7 Idle + Bluetooth Idle + WLAN Idle (2.4G) + USB Cable (Data Link with Notebook) + Earphone 1 + Battery + GNSS Rx + SIM 1<fig.3></p> <p>Mode 8 : USB Cable (Charging from Adapter 1) + Earphone 1 + Battery + FM Rx (88MHz) for Sample 1<fig.4></p> <p>Mode 9 : USB Cable (Charging from Adapter 1) + Earphone 1 + Battery + FM Rx (98MHz) for Sample 1<fig.4></p> <p>Mode 10 : USB Cable (Charging from Adapter 1) + Earphone 1 + Battery + FM Rx (108MHz) for Sample 1<fig.4></p> <p>Mode 11 : USB Cable (Charging from Adapter 2) + Earphone 2 + Battery + FM Rx (88MHz) for Sample 1<fig.4></p>
Radiated Emissions ≥ 1GHz	<p>Mode 1 : WCDMA Band II Idle + Bluetooth Idle + WLAN Idle (2.4G) + USB Cable (Charging from Adapter1) + Earphone 1 + Battery + GNSS Rx <Fig.2></p> <p>Mode 2 : LTE Band 7 Idle + Bluetooth Idle + WLAN Idle (2.4G) + USB Cable (Data Link with Notebook) + Earphone 1 + Battery + GNSS Rx + SIM 1<Fig.3></p>
<p>Remark:</p> <ol style="list-style-type: none"> 1. The worst case of AC is mode 5; and USB Link is mode 7, the test data of these modes were reported. 2. The worst case of RE < 1G is mode 4; and USB Link is mode 7, the test data of these modes were reported. 3. Data Link with Notebook means data application transferred mode between EUT and Notebook 	

2.2. Connection Diagram of Test System

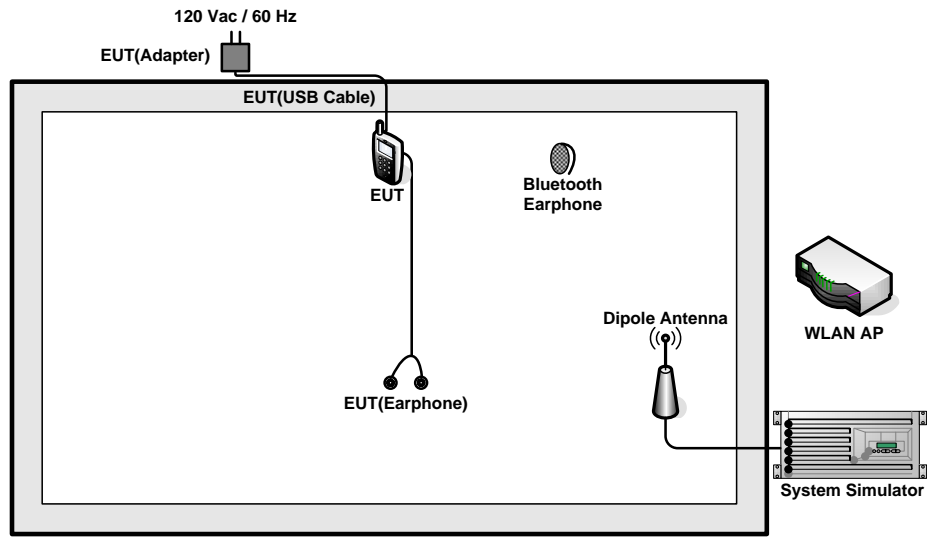

<Fig.1>

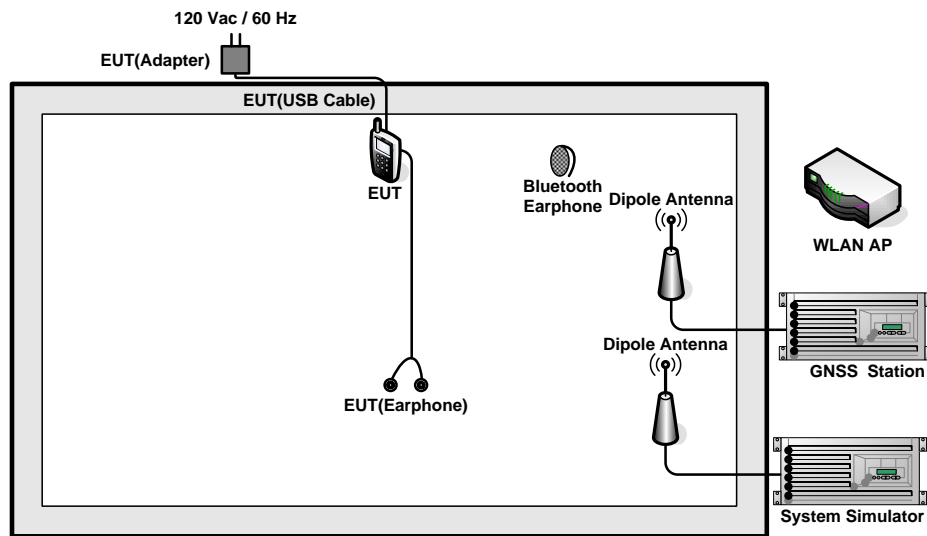

<Fig.2>

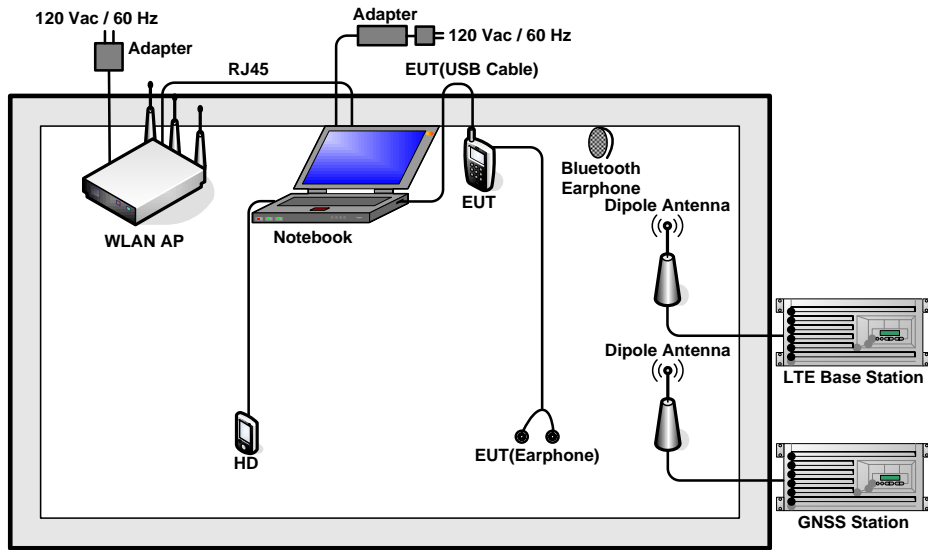

<Fig.3>

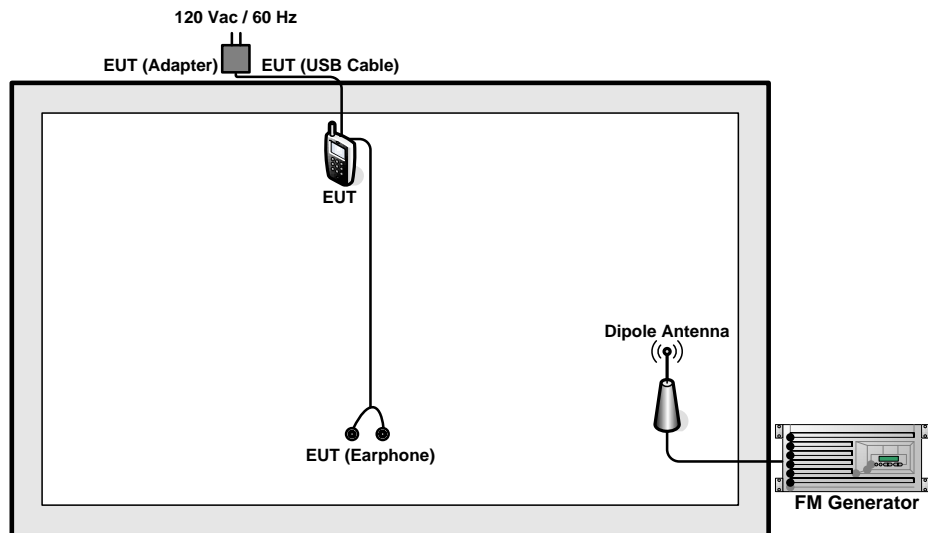

<Fig.4>



2.3. Support Unit used in test configuration and system

Item	Equipment	Trade Name	Model Name	FCC ID	Data Cable	Power Cord
1.	LTE Base Station	Anritsu	MT8820C	N/A	N/A	Unshielded,1.8m
2.	System Simulator	R&S	CMU200	N/A	N/A	Unshielded,1.8m
3.	GNSS Station	ADIVIC	MP9000	N/A	N/A	Unshielded,1.8m
4.	GNSS Station	RACELOGIC	RLLS03-2RP	N/A	N/A	Unshielded,1.8 m
5.	FM Generator	R&S	SMBV100A	N/A	N/A	Unshielded, 1.8 m
6.	WLAN AP	D-Link	DIR-855	KA2DIR855A2	N/A	Unshielded,1.8m
7.	WLAN AP	TP-LINK	TL-WDR5600	N/A	N/A	Unshielded, 1.8 m
8.	Notebook	Lenovo	G480	N/A	N/A	AC I/P: Unshielded, 1.8 m DC O/P: Shielded, 1.8 m
9.	Notebook	Lenovo	Y510P	N/A	N/A	shielded cable DC O/P 1.8m , Unshielded AC I/P cable 1.8m
10.	Bluetooth Earphone	Lenovo	LBH308	N/A	N/A	N/A
11.	SD Card	Kingston	8GB	N/A	N/A	N/A
12.	SD Card	SanDisk	Uitra	N/A	N/A	N/A
13.	Hard Disk	Lenovo	F310	DoC	Shielded, 1.2m	N/A



2.4. EUT Operation Test Setup

The EUT was in GSM or WCDMA or LTE idle mode during the testing. The EUT was synchronized to the BCCH, and is in continuous receiving mode by setting system simulator's paging reorganization.

At the same time, the EUT was attached to the Bluetooth earphone or WLAN AP, and the following programs installed in the EUT were programmed during the test.

1. Data application is transferred between Notebook and EUT via USB cable.
2. Turn on GNSS function to make the EUT receive continuous signals from GNSS station.
3. Turn on FM function to make the EUT receive continuous signals from FM Generator.
4. Execute "Video player" to play MPEG4 files.
5. Turn on camera to capture images.
6. Turn on NFC function.

3. Test Result

3.1. Test of AC Conducted Emission Measurement

3.1.1 Limits of AC Conducted Emission

For equipment that is designed to be connected to the public utility (AC) power line, the radio frequency voltage that is conducted back onto the AC power line on any frequency or frequencies within the band 150 kHz to 30 MHz shall not exceed the limits in the following table.

Frequency of emission (MHz)	Conducted limit (dBuV)	
	Quasi-peak	Average
0.15-0.5	66 to 56*	56 to 46*
0.5-5	56	46
5-30	60	50

*Decreases with the logarithm of the frequency.

3.1.2 Measuring Instruments

The measuring equipment is listed in the section 4 of this test report.

3.1.3 Test Procedure

1. The EUT was placed 0.4 meter from the conducting wall of the shielding room was kept at least 80 centimeters from any other grounded conducting surface.
2. Connect EUT to the power mains through a line impedance stabilization network (LISN).
3. All the support units are connecting to the other LISN.
4. The LISN provides 50 ohm coupling impedance for the measuring instrument.
5. The FCC states that a 50 ohm, 50 microhenry LISN should be used.
6. Both sides of AC line were checked for maximum conducted interference.
7. The frequency range from 150 kHz to 30 MHz was searched.
8. Set the test-receiver system to Peak Detect Function and specified bandwidth (IF Bandwidth = 9kHz) with Maximum Hold Mode. Then measurement is also conducted by Average Detector and Quasi-Peak Detector Function respectively.

3.1.4 Test Setup

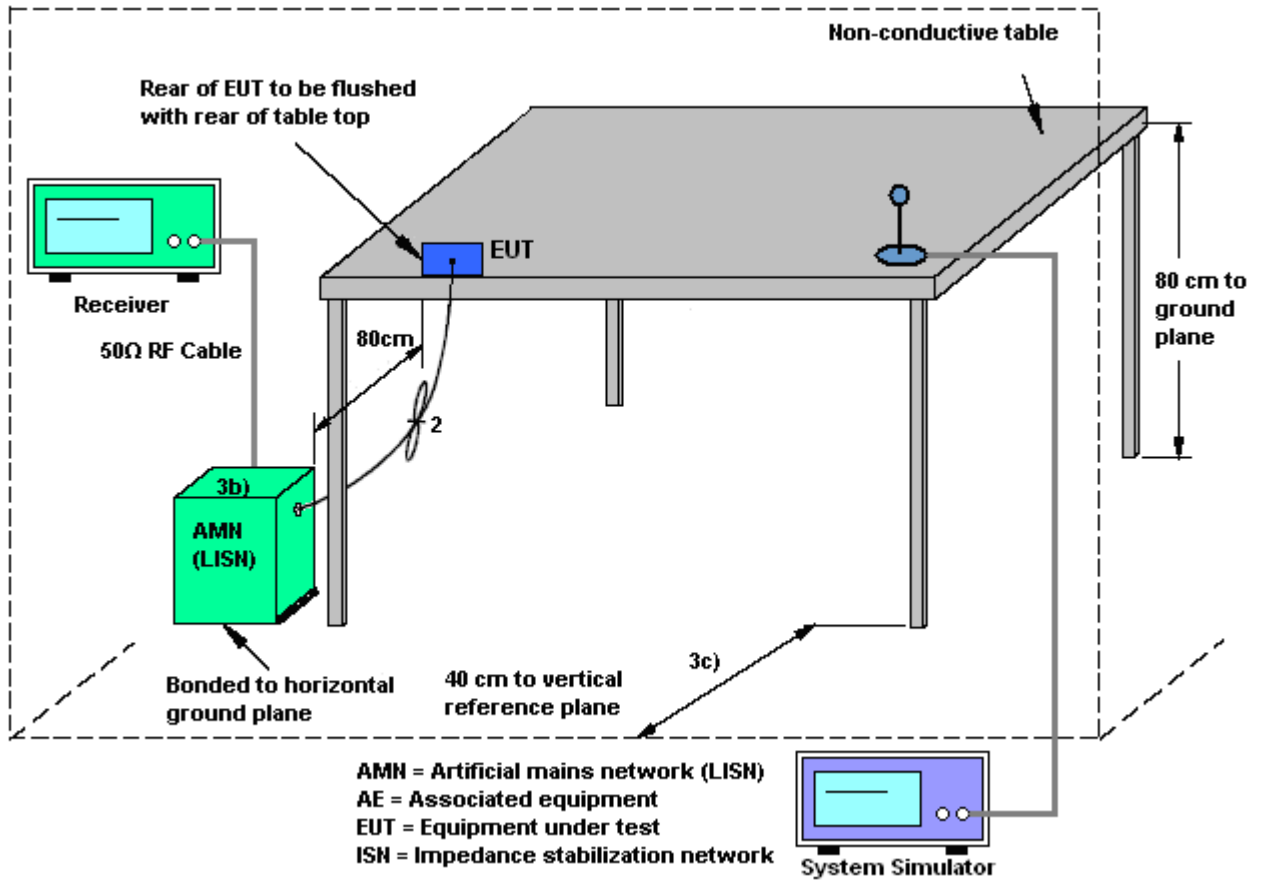



3.1.5 Test Result of AC Conducted Emission

Test Mode :	Mode 5	Temperature :	22~24°C
Test Engineer :	Amos Zhang	Relative Humidity :	41~44%
Test Voltage :	120Vac / 60Hz	Phase :	Line
Function Type :	WCDMA Band II Idle + Bluetooth Idle + WLAN Idle (2.4G) + USB Cable (Charging from Adapter1) + Earphone 1 + Battery + NFC On + SIM 2		

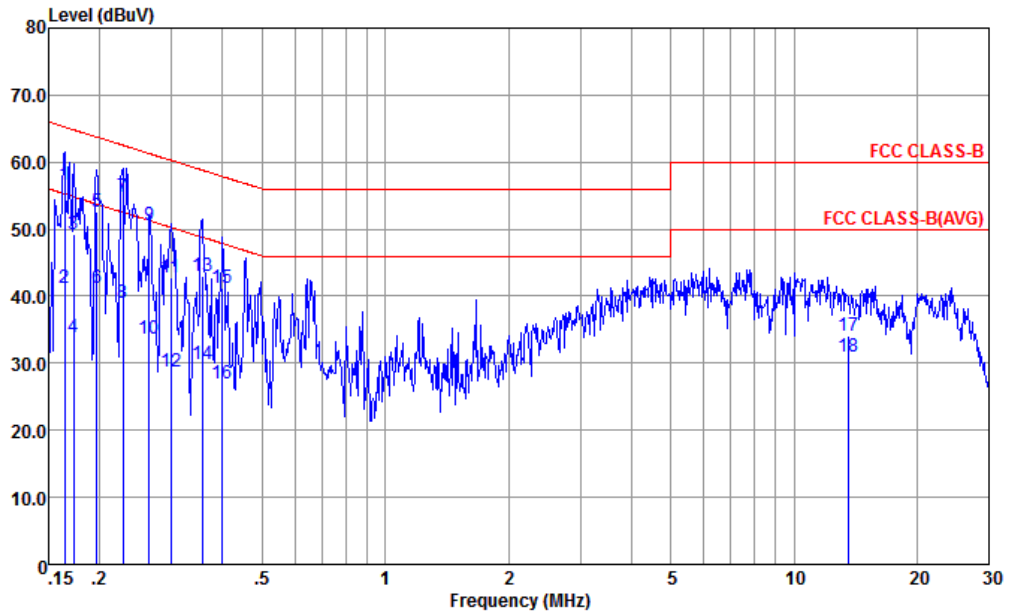

Site : CO01-KS
 Condition : FCC CLASS-B LISN-L-171013-060103 LINE
 Project : (FC) 7D2702-05

: 351855090018278/351855090018286 #2

	Freq	Level	Over Limit	Limit Line	Read Level	LISN Factor	Cable Loss	Remark
	MHz	dBuV	dB	dBuV	dBuV	dB	dB	
1	0.164	56.64	-8.61	65.25	45.90	0.17	10.57	QP
2	0.164	41.24	-14.01	55.25	30.50	0.17	10.57	Average
3	0.173	49.32	-15.49	64.81	38.60	0.18	10.54	QP
4	0.173	33.92	-20.89	54.81	23.20	0.18	10.54	Average
5	0.197	52.57	-11.19	63.76	41.90	0.20	10.47	QP
6	0.197	41.27	-12.49	53.76	30.60	0.20	10.47	Average
7 *	0.228	54.85	-7.67	62.52	44.19	0.21	10.45	QP
8	0.228	38.95	-13.57	52.52	28.29	0.21	10.45	Average
9	0.264	50.55	-10.74	61.29	39.89	0.22	10.44	QP
10	0.264	33.55	-17.74	51.29	22.89	0.22	10.44	Average
11	0.299	42.85	-17.43	60.28	32.19	0.23	10.43	QP
12	0.299	28.85	-21.43	50.28	18.19	0.23	10.43	Average
13	0.356	42.95	-15.88	58.83	32.29	0.24	10.42	QP
14	0.356	29.85	-18.98	48.83	19.19	0.24	10.42	Average
15	0.400	41.25	-16.61	57.86	30.59	0.25	10.41	QP
16	0.400	26.85	-21.01	47.86	16.19	0.25	10.41	Average
17	13.560	34.18	-25.82	60.00	23.51	0.28	10.39	QP
18	13.560	30.98	-19.02	50.00	20.31	0.28	10.39	Average



Test Mode :	Mode 5	Temperature :	22~24°C
Test Engineer :	Amos Zhang	Relative Humidity :	41~44%
Test Voltage :	120Vac / 60Hz	Phase :	Neutral
Function Type :	WCDMA Band II Idle + Bluetooth Idle + WLAN Idle (2.4G) + USB Cable (Charging from Adapter1) + Earphone 1 + Battery + NFC On + SIM 2		

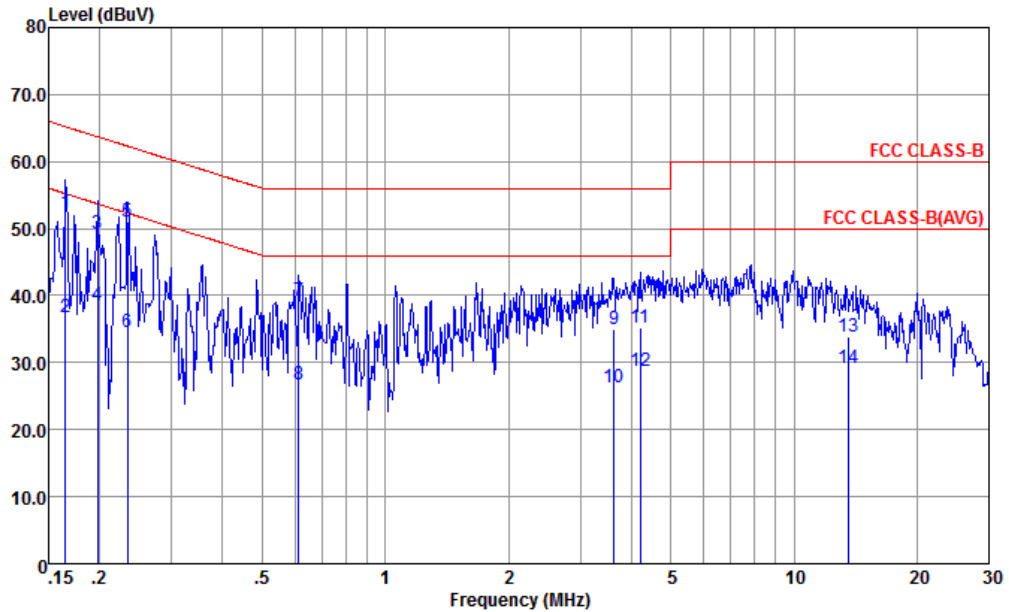

Site : CO01-KS
 Condition : FCC CLASS-B LISN-N-171013-060103 NEUTRAL
 Project : (FC) 7D2702-05

: 351855090018278/351855090018286 #2

	Freq	Level	Over Limit	Read Line	LISN Level	Cable Factor	Cable Loss	Remark
	MHz	dBuV	dB	dBuV	dBuV	dB	dB	
1	0.165	52.34	-12.87	65.21	41.50	0.28	10.56	QP
2	0.165	36.74	-18.47	55.21	25.90	0.28	10.56	Average
3	0.198	49.34	-14.37	63.71	38.60	0.28	10.46	QP
4	0.198	38.64	-15.07	53.71	27.90	0.28	10.46	Average
5 *	0.234	50.93	-11.37	62.30	40.21	0.28	10.44	QP
6	0.234	34.53	-17.77	52.30	23.81	0.28	10.44	Average
7	0.614	39.11	-16.89	56.00	28.59	0.30	10.22	QP
8	0.614	26.71	-19.29	46.00	16.19	0.30	10.22	Average
9	3.623	35.01	-20.99	56.00	24.51	0.33	10.17	QP
10	3.623	26.41	-19.59	46.00	15.91	0.33	10.17	Average
11	4.202	35.12	-20.88	56.00	24.60	0.34	10.18	QP
12	4.202	28.72	-17.28	46.00	18.20	0.34	10.18	Average
13	13.560	33.93	-26.07	60.00	23.31	0.23	10.39	QP
14	13.560	29.13	-20.87	50.00	18.51	0.23	10.39	Average



Test Mode :	Mode 7	Temperature :	22~24°C
Test Engineer :	Amos Zhang	Relative Humidity :	41~44%
Test Voltage :	120Vac / 60Hz	Phase :	Line
Function Type :	LTE Band 7 Idle + Bluetooth Idle + WLAN Idle (2.4G) + USB Cable (Data Link with Notebook) + Earphone 1 + Battery + GNSS Rx + SIM 1		

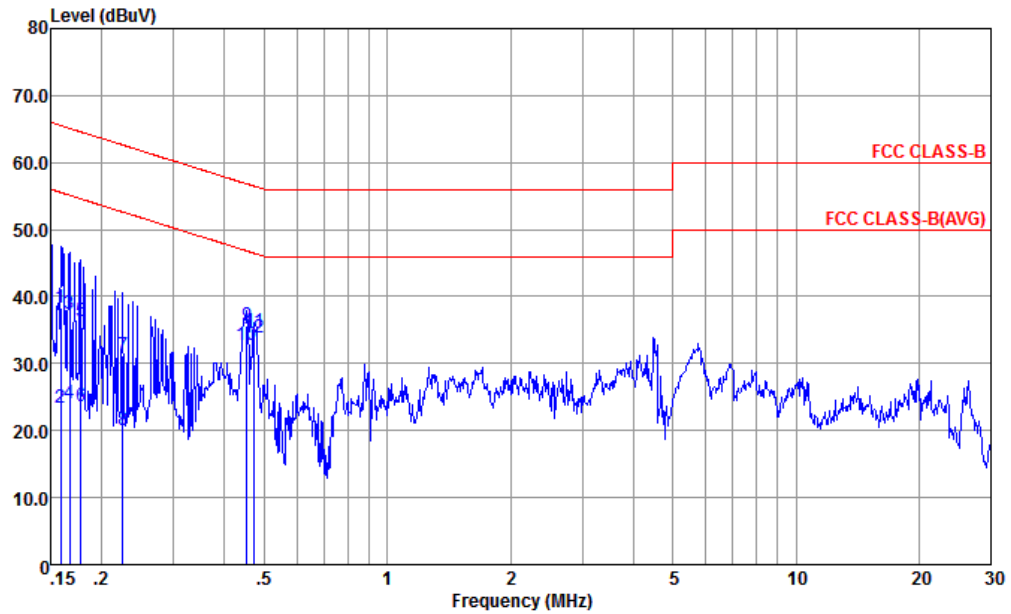

Site : CO01-KS
 Condition : FCC CLASS-B LISN-L-161017-060103 LINE
 Project : (FC) 7D2702-05

: 351855090018278/351855090018286 #2

	Freq	Level	Over Limit	Limit Line	Read Level	LISN Factor	Cable Loss	Remark
	MHz	dBuV	dB	dBuV	dBuV	dB	dB	
1	0.159	38.28	-27.24	65.52	27.41	0.49	10.38	QP
2	0.159	23.38	-32.14	55.52	12.51	0.49	10.38	Average
3	0.167	37.42	-27.70	65.12	26.60	0.45	10.37	QP
4	0.167	24.12	-31.00	55.12	13.30	0.45	10.37	Average
5	0.178	36.34	-28.25	64.59	25.60	0.38	10.36	QP
6	0.178	23.54	-31.05	54.59	12.80	0.38	10.36	Average
7	0.226	31.18	-31.43	62.61	20.60	0.27	10.31	QP
8	0.226	20.08	-32.53	52.61	9.50	0.27	10.31	Average
9	0.454	35.66	-21.14	56.80	25.20	0.27	10.19	QP
10	0.454	32.76	-14.04	46.80	22.30	0.27	10.19	Average
11	0.474	34.76	-21.69	56.45	24.30	0.27	10.19	QP
12 *	0.474	33.86	-12.59	46.45	23.40	0.27	10.19	Average



Test Mode :	Mode 7	Temperature :	22~24°C
Test Engineer :	Amos Zhang	Relative Humidity :	41~44%
Test Voltage :	120Vac / 60Hz	Phase :	Neutral
Function Type :	LTE Band 7 Idle + Bluetooth Idle + WLAN Idle (2.4G) + USB Cable (Data Link with Notebook) + Earphone 1 + Battery + GNSS Rx + SIM 1		

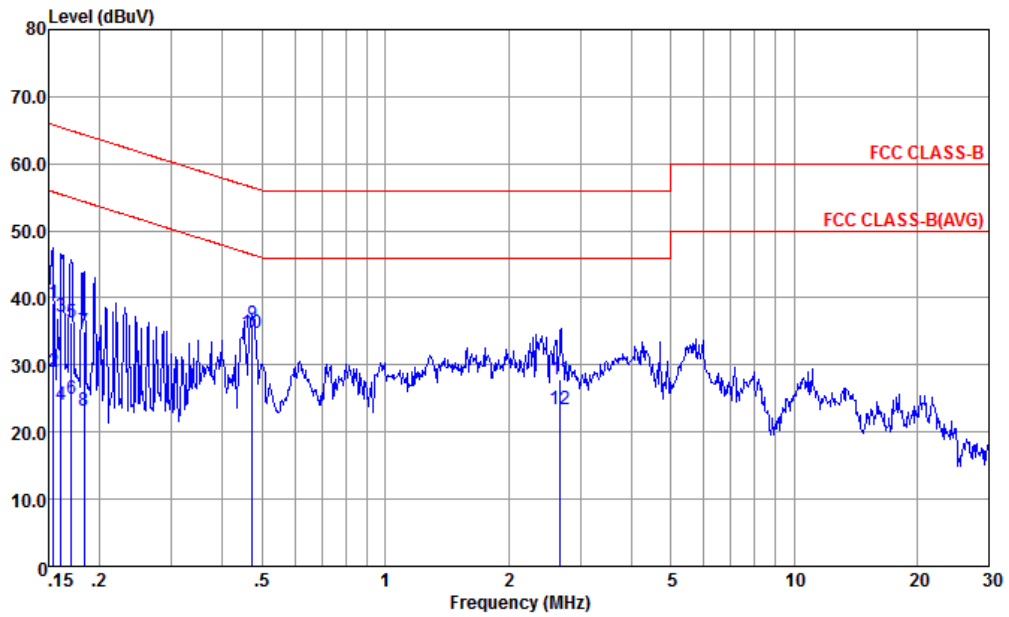

Site : CO01-KS
 Condition : FCC CLASS-B LISN-N-161017-060103 NEUTRAL
 Project : (FC) 7D2702-05

: 351855090018278/351855090018286 #2

	Freq	Level	Over Limit	Limit Line	Read Level	LISN Factor	Cable Loss	Remark
	MHz	dBuV	dB	dBuV	dBuV	dB	dB	
1	0.154	39.23	-26.55	65.78	28.50	0.34	10.39	QP
2	0.154	29.03	-26.75	55.78	18.30	0.34	10.39	Average
3	0.161	37.32	-28.11	65.43	26.60	0.34	10.38	QP
4	0.161	24.02	-31.41	55.43	13.30	0.34	10.38	Average
5	0.170	36.30	-28.64	64.94	25.59	0.34	10.37	QP
6	0.170	24.90	-30.04	54.94	14.19	0.34	10.37	Average
7	0.183	34.88	-29.45	64.33	24.20	0.33	10.35	QP
8	0.183	23.28	-31.05	54.33	12.60	0.33	10.35	Average
9	0.474	36.07	-20.38	56.45	25.50	0.38	10.19	QP
10 *	0.474	34.67	-11.78	46.45	24.10	0.38	10.19	Average
11	2.678	27.91	-28.09	56.00	17.30	0.40	10.21	QP
12	2.678	23.51	-22.49	46.00	12.90	0.40	10.21	Average

3.2. Test of Radiated Emission Measurement

3.2.1. Limit of Radiated Emission

The emissions from an unintentional radiator shall not exceed the field strength levels specified in the following table:

Frequency (MHz)	Field Strength (microvolts/meter)	Measurement Distance (meters)
30 – 88	100	3
88 – 216	150	3
216 - 960	200	3
Above 960	500	3

3.2.2. Measuring Instruments

The measuring equipment is listed in the section 4 of this test report.

3.2.3. Test Procedures

1. The EUT was placed on a turntable with 0.8 meter above ground.
2. The EUT was set 3 meters from the interference receiving antenna, which was mounted on the top of a variable height antenna tower.
3. The table was rotated 360 degrees to determine the position of the highest radiation.
4. The antenna is a Bi-Log antenna and its height is adjusted between one to four meters above ground to find the maximum value of the field strength for both horizontal polarization and vertical polarization of the antenna.
5. For each suspected emission, the EUT was arranged to its worst case and then tune the antenna tower (from 1 m to 4 m) and turntable (from 0 degree to 360 degrees) to find the maximum reading.
6. Set the test-receiver system to Peak Detect Function and specified bandwidth with Maximum Hold Mode (RBW=120kHz/VBW=300kHz for frequency below 1GHz; RBW=1MHz VBW=3MHz (Peak), RBW=1MHz/VBW=10Hz (Average) for frequency above 1GHz).
7. If the emission level of the EUT in peak mode was 3 dB lower than the limit specified, peak values of EUT will be reported. Otherwise, the emission will be repeated by using the quasi-peak method and reported.
8. Emission level (dB μ V/m) = 20 log Emission level (μ V/m)
9. Corrected Reading: Antenna Factor + Cable Loss + Read Level - Preamp Factor = Level

3.2.4. Test Setup of Radiated Emission

For radiated emissions from 30MHz to 1GHz

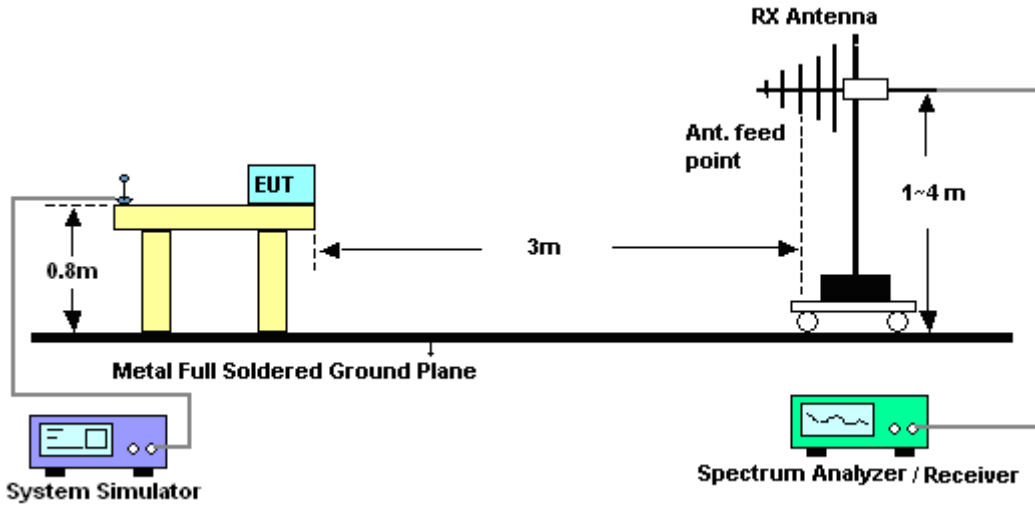

For radiated emissions above 1GHz

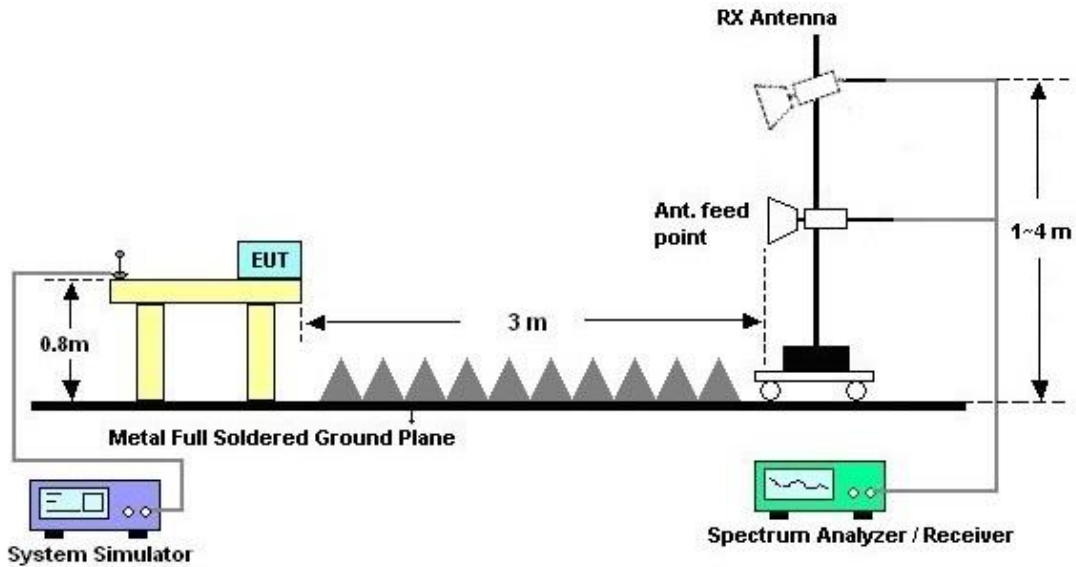



3.2.5. Test Result of Radiated Emission

Test Mode :	Mode 4	Temperature :	21~22°C
Test Engineer :	Maker Qi	Relative Humidity :	41~42%
Test Distance :	3m	Polarization :	Horizontal
Function Type :	WCDMA Band II Idle + Bluetooth Idle + WLAN Idle (2.4G) + USB Cable (Charging from Adapter1) + Earphone 1 + Battery + GNSS Rx		

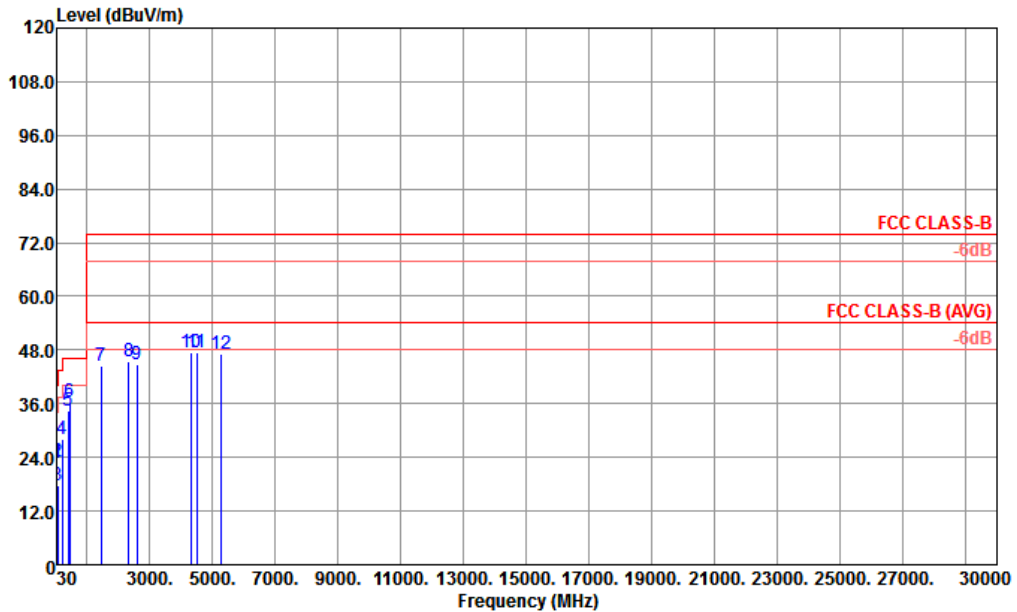

Site : 03CH02-KS
 Condition : FCC CLASS-B 3m LF 47610 HORIZONTAL
 Project : (FC)7D2702-05
 IMEI : 351855090018294 351855090018302 #6

	Freq	Level	Over	Limit	ReadAntenna	Cable	Preamp	A/Pos	T/Pos	Remark	
	MHz	dBuV/m	dB	dBuV/m	dBuV	dB/m	dB	dB	cm	deg	
1	30.27	22.84	-17.16	40.00	29.30	25.00	0.57	32.03	---	---	Peak
2	44.58	23.21	-16.79	40.00	38.36	16.30	0.66	32.11	---	---	Peak
3	70.50	17.86	-22.14	40.00	36.67	12.37	0.85	32.03	---	---	Peak
4	206.58	28.21	-15.29	43.50	43.03	15.34	1.49	31.65	---	---	Peak
5	404.30	34.37	-11.63	46.00	41.17	21.81	2.08	30.69	---	---	Peak
6	440.70	36.36	-9.64	46.00	42.18	22.59	2.16	30.57	100	0	Peak
7	1438.00	44.49	-29.51	74.00	46.55	28.75	3.95	34.76	---	---	Peak
8	2328.00	45.47	-28.53	74.00	40.85	31.19	5.07	31.64	---	---	Peak
9	2580.00	44.88	-29.12	74.00	38.55	31.62	5.34	30.63	---	---	Peak
10	4320.00	47.63	-26.37	74.00	34.94	35.61	7.21	30.13	---	---	Peak
11	4494.00	47.44	-26.56	74.00	34.30	35.90	7.39	30.15	---	---	Peak
12	5268.00	47.25	-26.75	74.00	38.74	35.30	7.81	34.60	---	---	Peak



Test Mode :	Mode 4	Temperature :	21~22°C
Test Engineer :	Maker Qi	Relative Humidity :	41~42%
Test Distance :	3m	Polarization :	Vertical
Function Type :	WCDMA Band II Idle + Bluetooth Idle + WLAN Idle (2.4G) + USB Cable (Charging from Adapter1) + Earphone 1 + Battery + GNSS Rx		

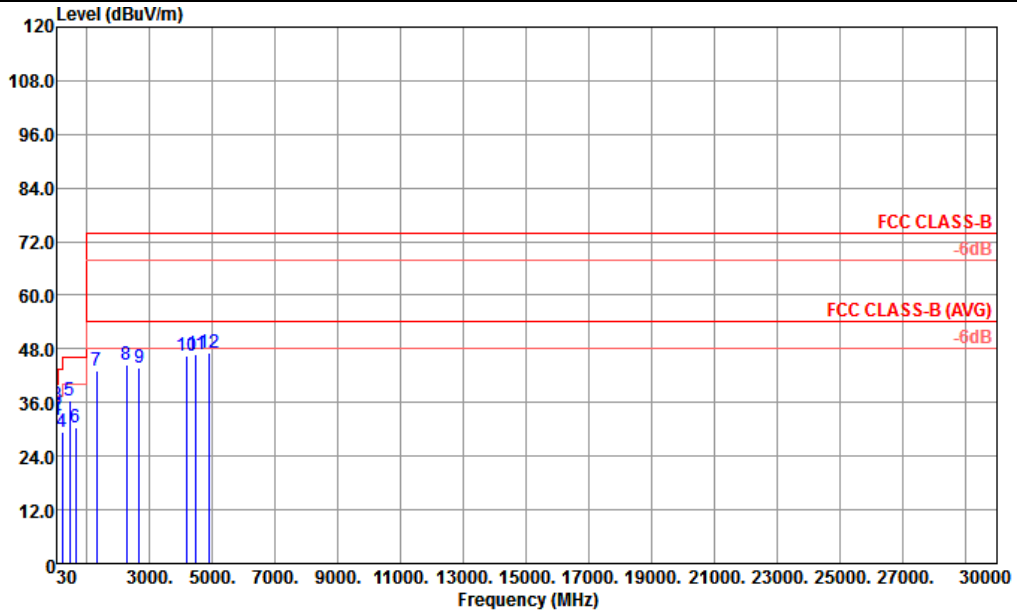

Site : 03CH02-KS
 Condition : FCC CLASS-B 3m LF 47610 VERTICAL
 Project : (FC)7D2702-05
 IMEI : 351855090018294 351855090018302 #6

	Freq	Level	Over Limit	Limit Line	ReadAntenna Level	Cable Preamp	A/Pos	T/Pos	Remark		
	MHz	dBuV/m	dB	dBuV/m	dBuV	dB/m	dB	dB	cm	deg	
1	33.78	32.07	-7.93	40.00	40.72	22.76	0.63	32.04	---	---	Peak
2	39.99	32.99	-7.01	40.00	45.19	19.20	0.64	32.04	---	---	Peak
3 !	44.85	35.35	-4.65	40.00	50.50	16.30	0.66	32.11	100	0	QP
4	200.91	29.30	-14.20	43.50	44.13	15.39	1.45	31.67	---	---	Peak
5	437.90	36.32	-9.68	46.00	42.20	22.55	2.15	30.58	---	---	Peak
6	638.10	30.32	-15.68	46.00	32.14	24.91	2.67	29.40	---	---	Peak
7	1312.00	43.16	-30.84	74.00	45.88	28.50	3.78	35.00	---	---	Peak
8	2262.00	44.44	-29.56	74.00	40.16	31.08	5.02	31.82	---	---	Peak
9	2654.00	43.85	-30.15	74.00	37.05	31.74	5.48	30.42	---	---	Peak
10	4185.00	46.37	-27.63	74.00	33.77	35.40	7.31	30.11	---	---	Peak
11	4467.00	46.85	-27.15	74.00	33.89	35.85	7.26	30.15	---	---	Peak
12	4896.00	47.01	-26.99	74.00	36.73	35.59	7.77	33.08	---	---	Peak



Test Mode :	Mode 7	Temperature :	21~22°C
Test Engineer :	Maker Qi	Relative Humidity :	41~42%
Test Distance :	3m	Polarization :	Horizontal
Function Type :	LTE Band 7 Idle + Bluetooth Idle + WLAN Idle (2.4G) + USB Cable (Data Link with Notebook) + Earphone 1 + Battery + GNSS Rx + SIM 1		

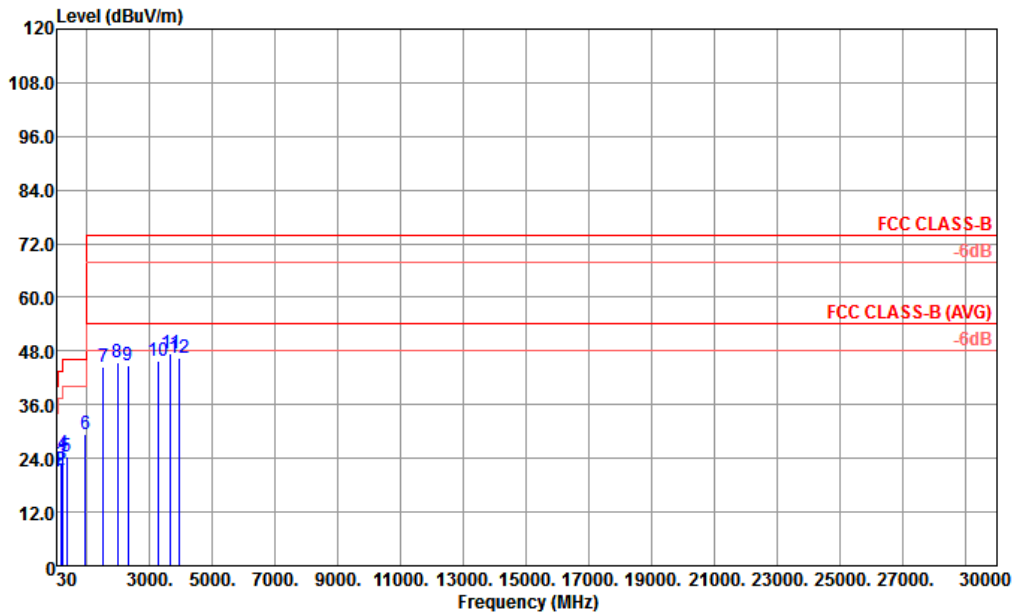

Site : 03CH02-KS
 Condition : FCC CLASS-B 3m LF 47610 HORIZONTAL
 Project : (FC)7D2702-05
 TMFT : 351855090018294 351855090018302 #6

	Freq	Level	Over	Limit	ReadAntenna	Cable	Preamp	A/Pos	T/Pos	Remark	
	MHz	dBuV/m	dB	dBuV/m	dBuV	dB/m	dB	dB	cm	deg	
1	30.00	21.00	-19.00	40.00	27.46	25.00	0.57	32.03	---	---	Peak
2	165.81	21.55	-21.95	43.50	36.16	15.86	1.32	31.79	---	---	Peak
3	194.43	22.70	-20.80	43.50	37.77	15.20	1.42	31.69	---	---	Peak
4	242.76	24.92	-21.08	46.00	37.12	17.67	1.70	31.57	---	---	Peak
5	344.80	24.40	-21.60	46.00	33.22	20.19	1.91	30.92	---	---	Peak
6	950.30	29.28	-16.72	46.00	26.30	26.91	3.20	27.13	100	0	Peak
7	1508.00	44.47	-29.53	74.00	46.29	28.85	4.05	34.72	---	---	Peak
8	1982.00	45.36	-28.64	74.00	43.96	30.19	4.61	33.40	---	---	Peak
9	2306.00	44.86	-29.14	74.00	40.36	31.16	5.04	31.70	---	---	Peak
10	3258.00	45.87	-28.13	74.00	36.23	33.19	6.23	29.78	---	---	Peak
11	3666.00	47.47	-26.53	74.00	36.66	34.14	6.51	29.84	---	---	Peak
12	3933.00	46.35	-27.65	74.00	34.77	35.01	6.68	30.11	---	---	Peak



Test Mode :	Mode 7	Temperature :	21~22°C
Test Engineer :	Maker Qi	Relative Humidity :	41~42%
Test Distance :	3m	Polarization :	Vertical
Function Type :	LTE Band 7 Idle + Bluetooth Idle + WLAN Idle (2.4G) + USB Cable (Data Link with Notebook) + Earphone 1 + Battery + GNSS Rx + SIM 1		

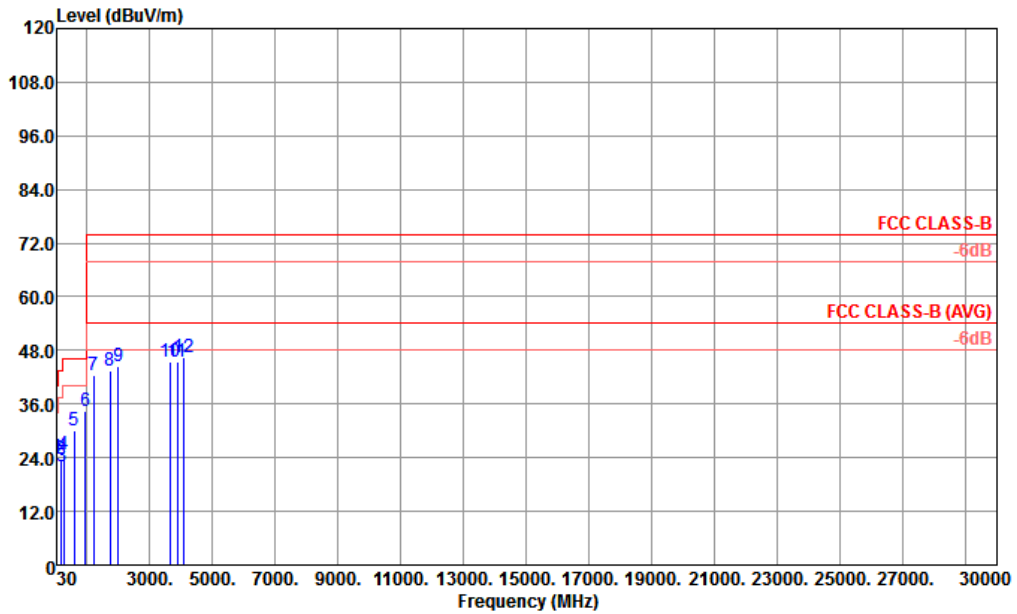

Site : 03CH02-KS
 Condition : FCC CLASS-B 3m LF 47610 VERTICAL
 Project : (FC)7D2702-05
 IMEI : 351855090018294 351855090018302 #6

	Freq	Level	Over	Limit	ReadAntenna	Cable	Preamp	A/Pos	T/Pos	Remark	
	MHz	dBuV/m	dB	dBuV/m	dBuV	dB/m	dB	dB	cm	deg	
1	42.69	24.01	-15.99	40.00	37.98	17.46	0.65	32.08	---	---	Peak
2	153.12	23.70	-19.80	43.50	37.88	16.38	1.27	31.83	---	---	Peak
3	194.43	22.05	-21.45	43.50	37.12	15.20	1.42	31.69	---	---	Peak
4	255.45	24.87	-21.13	46.00	35.51	19.10	1.77	31.51	---	---	Peak
5	597.50	30.14	-15.86	46.00	32.58	24.62	2.62	29.68	---	---	Peak
6	949.60	34.38	-11.62	46.00	31.42	26.90	3.20	27.14	100	0	Peak
7	1206.00	42.58	-31.42	74.00	45.86	28.30	3.65	35.23	---	---	Peak
8	1734.00	43.55	-30.45	74.00	44.25	29.20	4.38	34.28	---	---	Peak
9	1998.00	44.50	-29.50	74.00	42.97	30.30	4.63	33.40	---	---	Peak
10	3645.00	45.37	-28.63	74.00	34.60	34.03	6.49	29.75	---	---	Peak
11	3870.00	45.36	-28.64	74.00	33.91	34.90	6.66	30.11	---	---	Peak
12	4083.00	46.55	-27.45	74.00	34.49	35.23	6.94	30.11	---	---	Peak



4. List of Measuring Equipment

Instrument	Manufacturer	Model No.	Serial No.	Characteristics	Calibration Date	Test Date	Due Date	Remark
EMI Receiver	R&S	ESCI7	100768	9kHz~7GHz;	Apr. 20, 2017	Feb. 07, 2018	Apr. 19, 2018	Conduction (CO01-KS)
AC LISN	MessTec	AN3016	060103	9kHz~30MHz	Oct. 13, 2017	Feb. 07, 2018	Oct. 12, 2018	Conduction (CO01-KS)
AC LISN (for auxiliary equipment)	MessTec	AN3016	060105	9kHz~30MHz	Oct. 13, 2017	Feb. 07, 2018	Oct. 12, 2018	Conduction (CO01-KS)
AC Power Source	Chroma	61602	ABP000000 811	AC 0V~300V, 45Hz~1000Hz	Oct. 12, 2017	Feb. 07, 2018	Oct. 11, 2018	Conduction (CO01-KS)
EMI Test Receiver	R&S	ESR7	101403	9kHz~7GHz; Max 30dBm	Aug. 08, 2017	Feb. 05, 2018~ Feb. 09, 2018	Aug. 07, 2018	Radiation (03CH02-KS)
EXA Spectrum Analyzer	Keysight	N9010A	MY551502 08	10Hz~44GHz, MAX 30dB	Apr. 18, 2017	Feb. 05, 2018~ Feb. 09, 2018	Apr. 17, 2018	Radiation (03CH02-KS)
Bilog Antenna	TeseQ	CBL6112D	23182	30MHz~2GHz	Nov. 29, 2017	Feb. 05, 2018~ Feb. 09, 2018	Nov. 28, 2018	Radiation (03CH02-KS)
Double Ridge Horn Antenna	ETS-Lindgren	3117	75957	1GHz~18GHz	Oct. 21, 2017	Feb. 05, 2018~ Feb. 09, 2018	Oct. 20, 2018	Radiation (03CH02-KS)
SHF-EHF Horn	Schwarzbeck	BBHA 9170	BBHA1702 49	15GHz~40GHz	Feb. 15, 2017	Feb. 05, 2018~ Feb. 09, 2018	Feb. 14, 2018	Radiation (03CH02-KS)
Amplifier	SONOMA	310N	187289	9kHz~1GHz	Aug. 07, 2017	Feb. 05, 2018~ Feb. 09, 2018	Aug. 06, 2018	Radiation (03CH02-KS)
Amplifier	Agilent	8449B	3008A0238 4	1-26.5GHz Gain 30dB	Oct. 12, 2017	Feb. 05, 2018~ Feb. 09, 2018	Oct. 11, 2018	Radiation (03CH02-KS)
Amplifier	MITEQ	TTA1840-35-HG	1887435	18GHz~40GHz	Oct. 12, 2017	Feb. 05, 2018~ Feb. 09, 2018	Oct. 11, 2018	Radiation (03CH02-KS)
AC Power Source	Chroma	61601	616010002 473	N/A	NCR	Feb. 05, 2018~ Feb. 09, 2018	NCR	Radiation (03CH02-KS)
Turn Table	MF	MF7802	N/A	0~360 degree	NCR	Feb. 05, 2018~ Feb. 09, 2018	NCR	Radiation (03CH02-KS)
Antenna Mast	MF	MF7802	N/A	1 m~4 m	NCR	Feb. 05, 2018~ Feb. 09, 2018	NCR	Radiation (03CH02-KS)

NCR: No Calibration Required



5. Uncertainty of Evaluation

Uncertainty of Conducted Emission Measurement (150 kHz ~ 30 MHz)

Measuring Uncertainty for a Level of Confidence of 95% ($U = 2Uc(y)$)	2.3dB
---	-------

Uncertainty of Radiated Emission Measurement (30 MHz ~ 1000 MHz)

Measuring Uncertainty for a Level of Confidence of 95% ($U = 2Uc(y)$)	4.5dB
---	-------

Uncertainty of Radiated Emission Measurement (1GHz ~ 18GHz)

Measuring Uncertainty for a Level of Confidence of 95% ($U = 2Uc(y)$)	4.2dB
---	-------

Uncertainty of Radiated Emission Measurement (18GHz ~ 40GHz)

Measuring Uncertainty for a Level of Confidence of 95% ($U = 2Uc(y)$)	4.7dB
---	-------