



FCC RF Test Report

APPLICANT : Motorola Mobility LLC
EQUIPMENT : Mobile Cellular Phone
BRAND NAME : Motorola
MODEL NAME : XT1926-5
FCC ID : IHDT56WL3
STANDARD : FCC Part 15 Subpart C §15.225
CLASSIFICATION : (DXX) Low Power Communication Device Transmitter

The product was received on Dec. 28, 2017 and testing was completed on Feb. 01, 2018. We, SPORTON INTERNATIONAL INC., would like to declare that the tested sample has been evaluated in accordance with the test procedures and has been in compliance with the applicable technical standards.

The test results in this report apply exclusively to the tested model / sample. Without written approval of SPORTON INTERNATIONAL INC., the test report shall not be reproduced except in full.

Reviewed by: Joseph Lin / Supervisor

Approved by: Jones Tsai / Manager



SPORTON INTERNATIONAL INC.

No. 52, Hwa Ya 1st Rd., Hwa Ya Technology Park, Kwei-Shan District, Tao Yuan City, Taiwan, R.O.C.



TABLE OF CONTENTS

TABLE OF CONTENTS2

REVISION HISTORY3

SUMMARY OF THE TEST RESULT4

1. GENERAL INFORMATION.....5

 1.1 Applicant..... 5

 1.2 Manufacturer 5

 1.3 Product Feature of Equipment Under Test 5

 1.4 Product Specification of Equipment Under Test 5

 1.5 Re-use of Measured Data 6

 1.6 Specification of Accessory..... 7

 1.7 Modification of EUT 8

 1.8 Testing Location 8

 1.9 Applicable Standards..... 8

2. TEST CONFIGURATION OF EQUIPMENT UNDER TEST9

 2.1 Descriptions of Test Mode 9

 2.2 Connection Diagram of Test System 9

 2.3 Table for Supporting Units 10

 2.4 EUT Operation Test Setup 10

3. TEST RESULTS.....11

 3.1 Field Strength of Fundamental Emissions and Mask Measurement..... 11

 3.2 Radiated Emissions Measurement 13

4. LIST OF MEASURING EQUIPMENT16

APPENDIX A. TEST RESULTS OF RADIATED TEST ITEMS

 A1. Test Result of Field Strength of Fundamental Emissions

 A2. Results of Radiated Emissions (9 kHz~30MHz)

 A3. Results of Radiated Emissions (30MHz~1GHz)

APPENDIX B. SETUP PHOTOGRAPHS

APPENDIX C. REFERENCE REPORT



SUMMARY OF THE TEST RESULT

Applied Standard: 47 CFR FCC Part 15 Subpart C				
Part	FCC Rule	Description of Test	Result	Remark
3.1	15.225(a)(b)(c)	Field Strength of Fundamental Emissions	Complies	Max Level 56.74 dBuV/m at 13.560 MHz
3.2	15.225(d) 15.209	Radiated Emissions	Complies	Under limit 6.84 dB at 30.000 MHz

Test Items	Uncertainty	Remark
Radiated Emissions (30MHz~1000MHz)	±5.1dB	Confidence levels of 95%



1. GENERAL INFORMATION

1.1 Applicant

Motorola Mobility LLC
222 W, Merchandise Mart Plaza, Chicago IL 60654 USA

1.2 Manufacturer

Motorola Mobility LLC
222 W, Merchandise Mart Plaza, Chicago IL 60654 USA

1.3 Product Feature of Equipment Under Test

Product Feature	
Equipment	Mobile Cellular Phone
Brand Name	Motorola
Model Name	XT1926-5
FCC ID	IHDT56WL3
EUT supports Radios application	GSM/GPRS/EGPRS/WCDMA/HSPA/DC-HSDPA/HSPA+(16QAM uplink is not supported)/LTE/NFC WLAN 2.4GHz 802.11b/g/n HT20 WLAN 5GHz 802.11a/n HT20/HT40 WLAN 5GHz 802.11ac VHT20/VHT40/VHT80 Bluetooth v3.0+EDR/ Bluetooth v4.0 LE/ Bluetooth v4.1 LE/ Bluetooth v4.2 LE/ Bluetooth v5.0 LE
IMEI Code	Radiation: 351855090018252/ 351855090018260
HW Version	DVT1B
SW Version	evert_n-userdebug 8.0.0 OPW27.88 1825 intcfg,test-keys
EUT Stage	Identical Prototype

Remark: The above EUT's information was declared by manufacturer. Please refer to the specifications or user's manual for more detailed description.

1.4 Product Specification of Equipment Under Test

Standards-related Product Specification	
Tx/Rx Frequency Range	13.553 ~ 13.567MHz
Channel Number	1
Antenna Type	Loop Antenna
Type of Modulation	ASK

Remark: The above EUT's information was declared by manufacturer. Please refer to the specifications or user's manual for more detailed description.



1.5 Re-use of Measured Data

1.5.1 Introduction Section

This application re-uses data collected on a similar device. The subject device of this application (Model: XT1926-5, FCC ID: IHDT56WL3) is electrically identical to the reference device (Model: XT1926-6, XT1926-7, FCC ID: IHDT56WL4) for the portions of the circuitry corresponding to the data being re-used, as treated by KDB Publication 178919 D01.

1.5.2 Difference Section

For details concerning the similarity with respect to component placement, mechanical/electrical design etc., please refer to the Product Equality Declaration.

The re-used RF data includes the following bands provided in Appendix C (Sporton RF Report No. FR7D2702D for the reference device Model: XT1926-6, XT1926-7, FCC ID: IHDT56WL4):

1.5.3 Spot Check Verification Data Section

In order to confirm hardware similarity of the subject device with the reference device, spot check measurements were performed on the subject device for Frequency Stability, the test result were consistent with FCC ID: IHDT56WL4.

Assertions concerning the similarity of these devices are based on representations by the applicant. The applicant accepts full responsibility for the validity of the similarity claim, and for the determination that verification test data are sufficient to support it.

1.5.4 Reference detail Section:

Equipment Class	Reference FCC ID	Folder Test	Report Title/Section
DSS	IHDT56WL4	Part15C(FR7D2702A)	All sections (except RSE) applicable
DTS (BLE)	IHDT56WL4	Part15C(FR7D2702B)	All sections (except RSE) applicable
DTS (WLAN)	IHDT56WL4	Part15C(FR7D2702C)	All sections (except RSE) applicable
DXX	IHDT56WL4	Part15C(FR7D2702D)	All sections (except RSE) applicable



1.6 Specification of Accessory

Specification of Accessory			
AC Adapter 1(US)	Brand Name	Motorola (Salom)	Model Name SC-22
	Power Rating	I/P: 100-240 Vac, 500mA, O/P: 5Vdc,3000mA or 9Vdc,1600mA or 12Vdc,1200mA	
AC Adapter 1(EU)	Brand Name	Motorola (Salom)	Model Name SC-23
	Power Rating	I/P: 100-240 Vac, 500mA, O/P: 5Vdc,3000mA or 9Vdc,1600mA or 12Vdc,1200mA	
AC Adapter 1(UK)	Brand Name	Motorola (Salom)	Model Name SC-24
	Power Rating	I/P: 100-240 Vac, 500mA, O/P: 5Vdc,3000mA or 9Vdc,1600mA or 12Vdc,1200mA	
AC Adapter 1(IN)	Brand Name	Motorola (Salom)	Model Name SC-25
	Power Rating	I/P: 100-240 Vac, 500mA, O/P: 5Vdc,3000mA or 9Vdc,1600mA or 12Vdc,1200mA	
AC Adapter 1(AU)	Brand Name	Motorola (Salom)	Model Name SC-26
	Power Rating	I/P: 100-240 Vac, 500mA, O/P: 5Vdc,3000mA or 9Vdc,1600mA or 12Vdc,1200mA	
AC Adapter 1 (Indonesia)	Brand Name	Motorola (Salom)	Model Name SC-23
	Power Rating	I/P: 100-240 Vac, 500mA, O/P: 5Vdc,3000mA or 9Vdc,1600mA or 12Vdc,1200mA	
AC Adapter 2(US)	Brand Name	Motorola (Chenyang)	Model Name SC-22
	Power Rating	I/P: 100-240 Vac, 500mA, O/P: 5Vdc,3000mA or 9Vdc,1600mA or 12Vdc,1200mA	
AC Adapter 2(EU)	Brand Name	Motorola (Chenyang)	Model Name SC-23
	Power Rating	I/P: 100-240 Vac, 500mA, O/P: 5Vdc,3000mA or 9Vdc,1600mA or 12Vdc,1200mA	
AC Adapter 2(UK)	Brand Name	Motorola (Chenyang)	Model Name SC-24
	Power Rating	I/P: 100-240 Vac, 500mA, O/P: 5Vdc,3000mA or 9Vdc,1600mA or 12Vdc,1200mA	
AC Adapter 2(IN)	Brand Name	Motorola (Chenyang)	Model Name SC-25
	Power Rating	I/P: 100-240 Vac, 500mA, O/P: 5Vdc,3000mA or 9Vdc,1600mA or 12Vdc,1200mA	
AC Adapter 2(AU)	Brand Name	Motorola (Chenyang)	Model Name SC-26
	Power Rating	I/P: 100-240 Vac, 500mA, O/P: 5Vdc,3000mA or 9Vdc,1600mA or 12Vdc,1200mA	
Battery	Brand Name	Motorola (ATL)	Model Name JT40
	Power Rating	3.8Vdc,3200mAh	Type Li-ion Polymer
Earphone 1	Brand Name	Motorola (Jiahe)	Model Name LS-118M-12
	Signal Line Type	1.2 meter, non-shielded cable, without ferrite core	
Earphone 2	Brand Name	Motorola (Lianyun)	Model Name TS910A-38AMS01WHR-M
	Signal Line Type	1.2 meter, non-shielded cable, without ferrite core	
USB Cable	Brand Name	Motorola (Liqi)	Model Name L32B-053000100-ALL
	Signal Line Type	1.0 meter, shielded cable, without ferrite core	



1.7 Modification of EUT

No modifications are made to the EUT during all test items.

1.8 Testing Location

SPORTON INTERNATIONAL INC. is accredited to ISO 17025 by Taiwan Accreditation Foundation (TAF code : 1190) and the FCC designation No. TW1190 under the FCC-recognized accredited testing laboratories by Mutual Recognition Agreement (MRA) in FCC Test.

Test Site	SPORTON INTERNATIONAL INC.	
Test Site Location	No.52, Huaya 1st Rd., Guishan Dist. Taoyuan City Taiwan Tel: 886-3-327-3456 FAX: +886-3-327-0978	
Test Site No.	Sporton Site No.	FCC Test Firm Registration No.
	03CH07-HY	553509
Test Engineer	Stan Hsieh	

Note: The test site complies with ANSI C63.4 2014 requirement.

1.9 Applicable Standards

According to the specifications of the manufacturer, the EUT must comply with the requirements of the following standards:

- ♦ FCC Part 15 Subpart C §15.225
- ♦ ANSI C63.10-2013

2. TEST CONFIGURATION OF EQUIPMENT UNDER TEST

2.1 Descriptions of Test Mode

Investigation has been done on all the possible configurations for searching the worst cases.

The following table is a list of the test modes shown in this test report.

Test Items	
Radiated Emissions 9kHz~30MHz	Radiated Emissions 30MHz~1GHz

The EUT pre-scanned in four NFC type, A, B, F, V. The worst type (type F) was recorded in this report. Pre-scanned tests, X, Y, Z in three orthogonal panels to determine the final configuration (Y plane as worst plane) from all possible combinations.

2.2 Connection Diagram of Test System

< For Fundamental Emissions and Mask and Radiated Emissions Measurement >

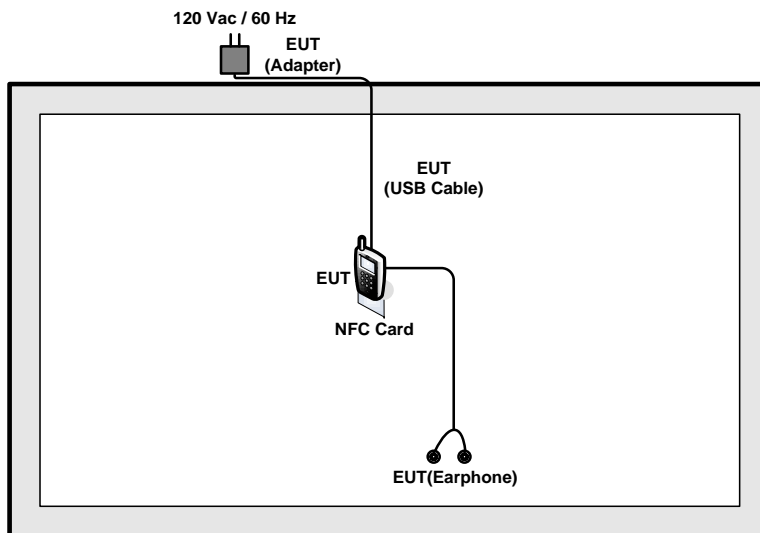



2.3 Table for Supporting Units

Support Unit	Manufacturer	Model	FCC ID
NFC Card	N/A	N/A	N/A

2.4 EUT Operation Test Setup

The EUT was programmed to be in continuously transmitting mode.

The ancillary equipment, NFC card, is used to make the EUT (NFC) continuously transmit at 13.56MHz and is placed around 3 cm gap to the EUT.



3. TEST RESULTS

3.1 Field Strength of Fundamental Emissions and Mask Measurement

3.1.1 Limit

Rules and specifications	FCC CFR 47 Part 15 section 15.225			
Description	Compliance with the spectrum mask is tested with RBW set to 9kHz.			
Freq. of Emission (MHz)	Field Strength (μV/m) at 30m	Field Strength (dBμV/m) at 30m	Field Strength (dBμV/m) at 10m	Field Strength (dBμV/m) at 3m
1.705~13.110	30	29.5	48.58	69.5
13.110~13.410	106	40.5	59.58	80.5
13.410~13.553	334	50.5	69.58	90.5
13.553~13.567	15848	84.0	103.08	124.0
13.567~13.710	334	50.5	69.58	90.5
13.710~14.010	106	40.5	59.58	80.5
14.010~30.000	30	29.5	48.58	69.5

3.1.2 Measuring Instruments

See list of measuring instruments of this test report.

3.1.3 Test Procedures

1. Configure the EUT according to ANSI C63.10. The EUT was placed on the top of the turntable 0.8 meter above ground. The phase center of the loop receiving antenna mounted antenna tower was placed 3 meters far away from the turntable.
2. Power on the EUT and all the supporting units. The turntable was rotated by 360 degrees to determine the position of the highest radiation.
3. The height of the receiving antenna was fixed at one meter above ground to find the maximum emissions field strength.
4. For Fundamental emissions, use the receiver to measure QP reading.

5. When the radiated emissions limits are expressed in terms of the average value of the emissions, and pulsed operation is employed, the measurement field strength shall be determined by averaging over one complete pulse train, including blanking intervals, as long as the pulse train does not exceed 0.1 seconds. As an alternative (provided the transmitter operates for longer than 0.1 seconds) or in cases where the pulse train exceeds 0.1 seconds, the measured field strength shall be determined from the average absolute voltage during a 0.1 second interval during which the field strength is at its maximum value.
6. Compliance with the spectrum mask is tested with RBW set to 9kHz.
Note: Emission level (dB μ V/m) = 20 log Emission level (μ V/m).

3.1.4 Test Setup

For radiated emissions below 30MHz

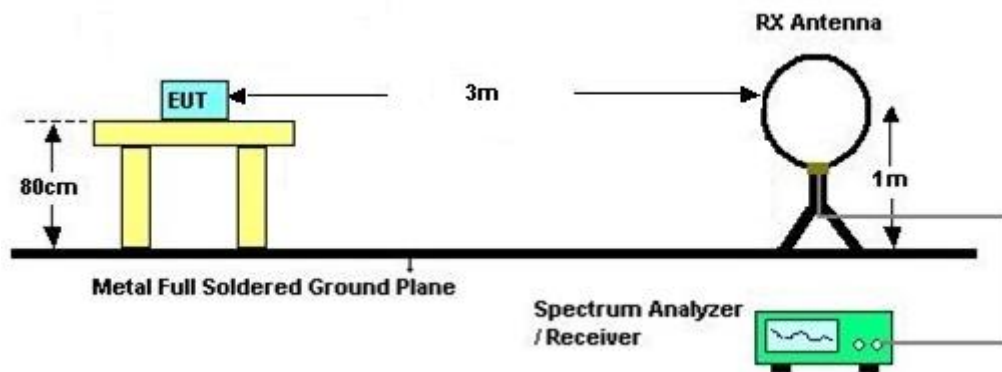

3.1.5 Test Result of Field Strength of Fundamental Emissions and Mask

Please refer to Appendix A.



3.2 Radiated Emissions Measurement

3.2.1 Limit

The field strength of any emissions which appear outside of 13.110 ~14.010MHz band shall not exceed the general radiated emissions limits.

Frequencies (MHz)	Field Strength (µV/m)	Measurement Distance (meters)
0.009~0.490	2400/F(kHz)	300
0.490~1.705	24000/F(kHz)	30
1.705~30.0	30	30
30~88	100	3
88~216	150	3
216~960	200	3
Above 960	500	3

3.2.2 Measuring Instruments

See list of measuring instruments of this test report.

3.2.3 Measuring Instrument Setting

The following table is the setting of receiver.

Receiver Parameter	Setting
Attenuation	Auto
Frequency Range: 9kHz~150kHz	RBW 200Hz for QP
Frequency Range: 150kHz~30MHz	RBW 9kHz for QP
Frequency Range: 30MHz~1000MHz	RBW 120kHz for Peak

Note: The emission limits shown in the above table are based on measurements employing a CISPR quasi-peak detector except for the frequency bands 9-90 kHz, 110-490 kHz. Radiated emission limits in these two bands are based on measurements employing an average detector.



3.2.4 Test Procedures

1. Configure the EUT according to ANSI C63.10. The EUT was placed on the top of the turntable 0.8 meter above ground. The phase center of the receiving antenna mounted on the top of a height-variable antenna tower was placed 3 meters far away from the turntable.
2. Power on the EUT and all the supporting units. The turntable was rotated by 360 degrees to determine the position of the highest radiation.
3. The height of the broadband receiving antenna was varied between one meter and four meters above ground to find the maximum emissions field strength of both horizontal and vertical polarization.
4. For each suspected emissions, the antenna tower was scan (from 1 M to 4 M) and then the turntable was rotated (from 0 degree to 360 degrees) to find the maximum reading.
5. Set the test-receiver system to Peak or CISPR quasi-peak Detect Function with specified bandwidth under Maximum Hold Mode.
6. When the radiated emissions limits are expressed in terms of the average value of the emissions, and pulsed operation is employed, the measurement field strength shall be determined by averaging over one complete pulse train, including blanking intervals, as long as the pulse train does not exceed 0.1 seconds. As an alternative (provided the transmitter operates for longer than 0.1 seconds) or in cases where the pulse train exceeds 0.1 seconds, the measured field strength shall be determined from the average absolute voltage during a 0.1 second interval during which the field strength is at its maximum value.
7. In case the emission is lower than 30MHz, loop antenna has to be used for measurement and the recorded data should be QP measured by receiver. Antenna Requirements

3.2.5 Test Setup

For radiated emissions above 30MHz

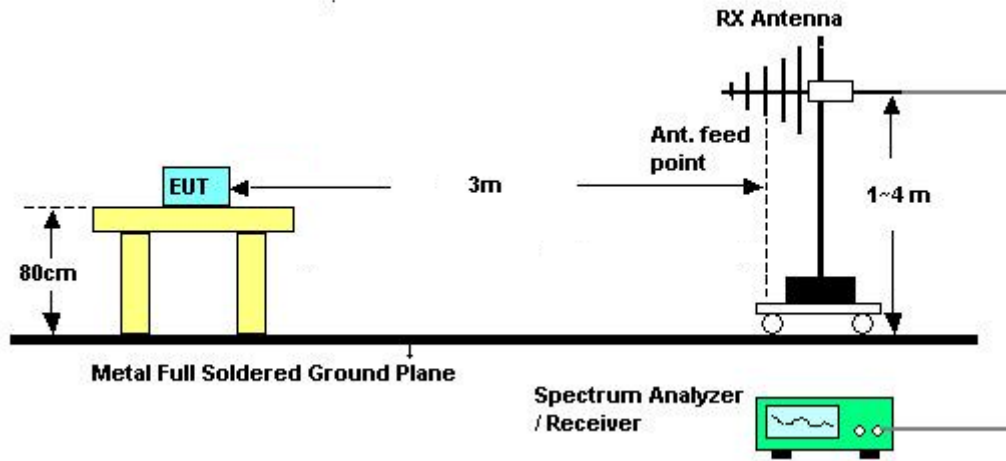

3.2.6 Test Result of Radiated Emissions Measurement

Please refer to Appendix A.



4. LIST OF MEASURING EQUIPMENT

Instrument	Manufacturer	Model No.	Serial No.	Characteristics	Calibration Date	Test Date	Due Date	Remark
EMI Test Receiver	Rohde & Schwarz	ESU26	100472	20Hz~26.5GHz	Jan. 04, 2018	Feb. 01, 2018	Jan. 03, 2019	Radiation (03CH07-HY)
Bilog Antenna	TESEQ	CBL 6111D&0080 0N1D01N-06	35419&03	30MHz to 1GHz	Dec. 18, 2017	Feb. 01, 2018	Dec. 17, 2018	Radiation (03CH07-HY)
Loop Antenna	Rohde & Schwarz	HFH2-Z2	100315	9 kHz~30 MHz	Nov. 10, 2017	Feb. 01, 2018	Nov. 09, 2018	Radiation (03CH07-HY)
Preamplifier	COM-POWER	PA-103A	161241	10MHz-1GHz	Mar. 14, 2017	Feb. 01, 2018	Mar. 13, 2018	Radiation (03CH07-HY)
Spectrum Analyzer	Agilent	N9010A	MY5347011 8	10Hz~44GHz	Apr. 17, 2017	Feb. 01, 2018	Apr. 16, 2018	Radiation (03CH07-HY)
Controller	ChainTek	Chaintek 3000	N/A	Control Turn table	NCR	Feb. 01, 2018	NCR	Radiation (03CH07-HY)
Antenna Mast	Max-Full	MFA520BS	N/A	1m~4m	NCR	Feb. 01, 2018	NCR	Radiation (03CH07-HY)
Turn Table	ChainTek	Chaintek 3000	N/A	0~360 Degree	NCR	Feb. 01, 2018	NCR	Radiation (03CH07-HY)

NCR: No Calibration Required



Appendix A. Test Results of Radiated Test Items

A1. Test Result of Field Strength of Fundamental Emissions

Test Mode :	NFC Tx	Test Frequency (MHz)	13.56																																
<p>Level (dBuV/m) vs Frequency (MHz) plot. Date: 2018-02-01. Site: :03CH07-HY. The red line represents the limit, and the blue line represents the measured signal. A peak is observed at 13.56 MHz.</p>																																			
<table border="1"> <thead> <tr> <th>Over</th> <th>Limit</th> <th>ReadAntenna</th> <th>Cable</th> <th>A/Pos</th> <th>T/Pos</th> <th>Remark</th> </tr> <tr> <th>Freq</th> <th>Level</th> <th>Line</th> <th>Level</th> <th>Loss</th> <th></th> <th></th> </tr> <tr> <th>MHz</th> <th>dBuV/m</th> <th>dB</th> <th>dBuV/m</th> <th>dB</th> <th>cm</th> <th>deg</th> </tr> </thead> <tbody> <tr> <td>1</td> <td>13.56</td> <td>56.74</td> <td>-67.26</td> <td>124.00</td> <td>36.11</td> <td>19.91</td> <td>0.72</td> <td>100</td> <td>0</td> <td>QP</td> </tr> </tbody> </table>				Over	Limit	ReadAntenna	Cable	A/Pos	T/Pos	Remark	Freq	Level	Line	Level	Loss			MHz	dBuV/m	dB	dBuV/m	dB	cm	deg	1	13.56	56.74	-67.26	124.00	36.11	19.91	0.72	100	0	QP
Over	Limit	ReadAntenna	Cable	A/Pos	T/Pos	Remark																													
Freq	Level	Line	Level	Loss																															
MHz	dBuV/m	dB	dBuV/m	dB	cm	deg																													
1	13.56	56.74	-67.26	124.00	36.11	19.91	0.72	100	0	QP																									
<p>Level (dBuV/m) vs Frequency (MHz) plot. Date: 2018-02-01. Site: :03CH07-HY. The red line represents the limit, and the blue line represents the measured signal. A peak is observed at 13.56 MHz.</p>																																			
<table border="1"> <thead> <tr> <th>Over</th> <th>Limit</th> <th>ReadAntenna</th> <th>Cable</th> <th>A/Pos</th> <th>T/Pos</th> <th>Remark</th> </tr> <tr> <th>Freq</th> <th>Level</th> <th>Line</th> <th>Level</th> <th>Loss</th> <th></th> <th></th> </tr> <tr> <th>MHz</th> <th>dBuV/m</th> <th>dB</th> <th>dBuV/m</th> <th>dB</th> <th>cm</th> <th>deg</th> </tr> </thead> <tbody> <tr> <td>1</td> <td>13.56</td> <td>53.65</td> <td>-70.35</td> <td>124.00</td> <td>33.02</td> <td>19.91</td> <td>0.72</td> <td>100</td> <td>282</td> <td>QP</td> </tr> </tbody> </table>				Over	Limit	ReadAntenna	Cable	A/Pos	T/Pos	Remark	Freq	Level	Line	Level	Loss			MHz	dBuV/m	dB	dBuV/m	dB	cm	deg	1	13.56	53.65	-70.35	124.00	33.02	19.91	0.72	100	282	QP
Over	Limit	ReadAntenna	Cable	A/Pos	T/Pos	Remark																													
Freq	Level	Line	Level	Loss																															
MHz	dBuV/m	dB	dBuV/m	dB	cm	deg																													
1	13.56	53.65	-70.35	124.00	33.02	19.91	0.72	100	282	QP																									



A2.Results of Radiated Spurious Emissions (9 kHz~30MHz)

Test Mode :	NFC Tx	Polarization :	Horizontal
--------------------	--------	-----------------------	------------

Frequency (MHz)	Level (dBμV/m)	Over Limit (dB)	Limit Line (dBμV/m)	Read Level (dBμV)	Antenna Factor (dB)	Cable Loss (dB)	Ant Pos (cm)	Table Pos (deg)	Remark
0.02405	52.31	-67.67	119.98	31.43	20.16	0.72	-	-	Average
0.07437	50.11	-60.07	110.18	29.29	20.1	0.72	-	-	Average
0.09882	48.6	-59.11	107.71	27.79	20.09	0.72	-	-	QP
0.11248	38.82	-67.76	106.58	18.01	20.09	0.72	-	-	Average
0.15238	52.56	-51.39	103.95	31.78	20.06	0.72	-	-	Average
0.51253	39.71	-33.7	73.41	19	19.99	0.72	-	-	QP
8.736	37.08	-32.42	69.5	16.39	19.97	0.72	-	-	QP
19.33	37.84	-31.66	69.5	16.97	20.15	0.72	100	0	QP
25.93	37.68	-31.82	69.5	15.5	20.47	1.71	-	-	QP

Test Mode :	NFC Tx	Polarization :	Vertical
--------------------	--------	-----------------------	----------

Frequency (MHz)	Level (dBμV/m)	Over Limit (dB)	Limit Line (dBμV/m)	Read Level (dBμV)	Antenna Factor (dB)	Cable Loss (dB)	Ant Pos (cm)	Table Pos (deg)	Remark
0.01313	52.57	-72.67	125.24	31.22	20.63	0.72	-	-	Average
0.07533	49.11	-60.96	110.07	28.29	20.1	0.72	-	-	Average
0.0989	42.4	-65.3	107.7	21.59	20.09	0.72	-	-	QP
0.12328	37.25	-68.54	105.79	16.46	20.07	0.72	-	-	Average
0.15034	49.95	-54.11	104.06	29.17	20.06	0.72	-	-	Average
6.979	39.5	-30	69.5	18.82	19.96	0.72	100	0	QP
9.744	37.43	-32.07	69.5	16.76	19.95	0.72	-	-	QP
23.794	37.69	-31.81	69.5	15.49	20.49	1.71	-	-	QP
26.075	37.92	-31.58	69.5	15.74	20.47	1.71	-	-	QP

Note:

1. The amplitude of spurious emissions which are attenuated by more than 20dB below the permissible value has no need to be reported.
2. Distance extrapolation factor = 40 log (specific distance / test distance) (dB);
3. Limit line = specific limits (dBμV) + distance extrapolation factor.



A3.Results of Radiated Spurious Emissions (30MHz~1GHz)

Test Mode :	NFC Tx	Polarization :	Horizontal
-------------	--------	----------------	------------

Frequency (MHz)	Level (dBμV/m)	Over Limit (dB)	Limit Line (dBμV/m)	Read Level (dBμV)	Antenna Factor (dB)	Cable Loss (dB)	Preamp Factor (dB)	Ant Pos (cm)	Table Pos (deg)	Remark
30	33.16	-6.84	40	38.03	24.6	1.71	31.35	100	0	Peak
44.85	26.23	-13.77	40	39.26	16.71	1.71	31.55	-	-	Peak
77.79	21.76	-18.24	40	38.1	13.01	2.11	31.58	-	-	Peak
739.6	33.71	-12.29	46	30.65	27.68	4.81	30.64	-	-	Peak
860	34.52	-11.48	46	29.77	29.03	5.2	30.55	-	-	Peak
944	35.95	-10.05	46	29.84	30.03	5.4	30.52	-	-	Peak

Test Mode :	NFC Tx	Polarization :	Vertical
-------------	--------	----------------	----------

Frequency (MHz)	Level (dBμV/m)	Over Limit (dB)	Limit Line (dBμV/m)	Read Level (dBμV)	Antenna Factor (dB)	Cable Loss (dB)	Preamp Factor (dB)	Ant Pos (cm)	Table Pos (deg)	Remark
30	28.14	-11.86	40	33.01	24.6	1.71	31.35	-	-	Peak
40.8	25.4	-14.6	40	36.25	18.81	1.71	31.49	-	-	Peak
78.87	23.68	-16.32	40	39.93	13.1	2.11	31.58	-	-	Peak
790.7	34.32	-11.68	46	30.39	27.97	4.98	30.6	-	-	Peak
877.5	34.91	-11.09	46	30.23	28.91	5.27	30.54	-	-	Peak
954.5	36.59	-9.41	46	29.81	30.59	5.4	30.51	100	0	Peak

Note:

1. The amplitude of spurious emissions which are attenuated by more than 20dB below the permissible value has no need to be reported.
2. Emission level (dBμV/m) = 20 log Emission level (μV/m).
3. Corrected Reading: Antenna Factor + Cable Loss + Read Level - Preamp Factor= Level.



Appendix C. Reference Report

Please refer to Sporton report number FR7D2702D which is issued separately.