



# FCC RF Test Report

APPLICANT : Motorola Mobility LLC  
EQUIPMENT : Mobile Cellular Phone  
BRAND NAME : Motorola  
MODEL NAME : XT1926-5  
FCC ID : IHDT56WL3  
STANDARD : FCC Part 15 Subpart C §15.247  
CLASSIFICATION : (DSS) Spread Spectrum Transmitter

The product was received on Dec. 28, 2017 and testing was completed on Feb. 13, 2018. We, SPORTON INTERNATIONAL INC., would like to declare that the tested sample has been evaluated in accordance with the test procedures and has been in compliance with the applicable technical standards.

The test results in this report apply exclusively to the tested model / sample. Without written approval of SPORTON INTERNATIONAL INC., the test report shall not be reproduced except in full.

Reviewed by: Joseph Lin / Supervisor

Approved by: Jones Tsai / Manager



**SPORTON INTERNATIONAL INC.**

No. 52, Hwa Ya 1<sup>st</sup> Rd., Hwa Ya Technology Park, Kwei-Shan District, Tao Yuan City, Taiwan, R.O.C.



# TABLE OF CONTENTS

**1 GENERAL DESCRIPTION..... 5**

1.1 Applicant ..... 5

1.2 Manufacturer..... 5

1.3 Product Feature of Equipment Under Test..... 5

1.4 Product Specification of Equipment Under Test..... 5

1.5 Modification of EUT ..... 6

1.6 Re-use of Measured Data ..... 6

1.7 Specification of Accessory..... 1

1.8 Testing Location ..... 2

1.9 Applicable Standards..... 2

**2 TEST CONFIGURATION OF EQUIPMENT UNDER TEST..... 3**

2.1 Test Mode..... 3

2.2 Connection Diagram of Test System..... 4

2.3 Support Unit used in test configuration and system ..... 4

2.4 EUT Operation Test Setup ..... 4

**3 TEST RESULT ..... 5**

3.1 Radiated Band Edges and Spurious Emission Measurement ..... 5

**4 LIST OF MEASURING EQUIPMENT..... 11**

**5 UNCERTAINTY OF EVALUATION..... 12**

**APPENDIX A. RADIATED SPURIOUS EMISSION**

**APPENDIX B. SETUP PHOTOGRAPHS**

**APPENDIX C. REFERENCE REPORT**





### SUMMARY OF TEST RESULT

Report Section	FCC Rule	Description	Limit	Result	Remark
3.1	15.247(d)	Radiated Band Edges and Radiated Spurious Emission	15.209(a) & 15.247(d)	Pass	Under limit 9.25 dB at 34.590 MHz



# 1 General Description

## 1.1 Applicant

**Motorola Mobility LLC**  
222 W,Merchandise Mart Plaza, Chicago IL 60654 USA

## 1.2 Manufacturer

**Motorola Mobility LLC**  
222 W,Merchandise Mart Plaza, Chicago IL 60654 USA

## 1.3 Product Feature of Equipment Under Test

Product Feature	
<b>Equipment</b>	Mobile Cellular Phone
<b>Brand Name</b>	Motorola
<b>Model Name</b>	XT1926-5
<b>FCC ID</b>	IHDT56WL3
<b>EUT supports Radios application</b>	GSM/GPRS/EGPRS/WCDMA/HSPA/DC-HSDPA/ HSPA+(16QAM uplink is not supported)/LTE/NFC WLAN 2.4GHz 802.11b/g/n HT20 WLAN 5GHz 802.11a/n HT20/HT40 WLAN 5GHz 802.11ac VHT20/VHT40/VHT80 Bluetooth v3.0+EDR/ Bluetooth v4.0 LE/ Bluetooth v4.1 LE/ Bluetooth v4.2 LE/ Bluetooth v5.0 LE
<b>IMEI Code</b>	Radiation: 351855090018252/ 351855090018260
<b>HW Version</b>	DVT1B
<b>SW Version</b>	evert_n-userdebug 8.0.0 OPW27.88 1825 intcfg,test-keys
<b>EUT Stage</b>	Identical Prototype

**Remark:** The above EUT's information was declared by manufacturer. Please refer to the specifications or user's manual for more detailed description.

## 1.4 Product Specification of Equipment Under Test

Standards-related Product Specification	
<b>Tx/Rx Frequency Range</b>	2402 MHz ~ 2480 MHz
<b>Number of Channels</b>	79
<b>Carrier Frequency of Each Channel</b>	2402+n*1 MHz; n=0~78
<b>Antenna Type / Gain</b>	PIFA Antenna with gain -2.8 dBi
<b>Type of Modulation</b>	Bluetooth BR (1Mbps) : GFSK Bluetooth EDR (2Mbps) : $\pi/4$ -DQPSK Bluetooth EDR (3Mbps) : 8-DPSK



### 1.5 Modification of EUT

No modifications are made to the EUT during all test items.

### 1.6 Re-use of Measured Data

#### 1.6.1 Introduction Section

This application re-uses data collected on a similar device. The subject device of this application (Model: XT1926-5, FCC ID: IHDT56WL3) is electrically identical to the reference device (Model: XT1926-6, XT1926-7, FCC ID: IHDT56WL4) for the portions of the circuitry corresponding to the data being re-used, as treated by KDB Publication 178919 D01.

#### 1.6.2 Difference Section

For details concerning the similarity with respect to component placement, mechanical/electrical design etc., please refer to the Product Equality Declaration.

The re-used RF data includes the following bands provided in Appendix C (Sporton RF Report No. FR7D2702A for the reference device Model: XT1926-6, XT1926-7, FCC ID: IHDT56WL4):

#### 1.6.3 Spot Check Verification Data Section

In order to confirm hardware similarity of the subject device with the reference device, spot check measurements were performed on the subject device for conducted power and conducted spurious emission, the test result were consistent with FCC ID: IHDT56WL4 and radiation spurious emission to full re-test.

Assertions concerning the similarity of these devices are based on representations by the applicant. The applicant accepts full responsibility for the validity of the similarity claim, and for the determination that verification test data are sufficient to support it.

#### 1.6.4 Reference detail Section:

Equipment Class	Reference FCC ID	Folder Test	Report Title/Section
DSS	IHDT56WL4	Part15C(FR7D2702A)	All sections (except RSE) applicable
DTS (BLE)	IHDT56WL4	Part15C(FR7D2702B)	All sections (except RSE) applicable
DTS (WLAN)	IHDT56WL4	Part15C(FR7D2702C)	All sections (except RSE) applicable
DXX	IHDT56WL4	Part15C(FR7D2702D)	All sections (except RSE) applicable



### 1.7 Specification of Accessory

Specification of Accessory			
AC Adapter 1(US)	Brand Name	Motorola (Salom)	Model Name SC-22
	Power Rating	I/P: 100-240 Vac, 500mA, O/P: 5Vdc,3000mA or 9Vdc,1600mA or 12Vdc,1200mA	
AC Adapter 1(EU)	Brand Name	Motorola (Salom)	Model Name SC-23
	Power Rating	I/P: 100-240 Vac, 500mA, O/P: 5Vdc,3000mA or 9Vdc,1600mA or 12Vdc,1200mA	
AC Adapter 1(UK)	Brand Name	Motorola (Salom)	Model Name SC-24
	Power Rating	I/P: 100-240 Vac, 500mA, O/P: 5Vdc,3000mA or 9Vdc,1600mA or 12Vdc,1200mA	
AC Adapter 1(IN)	Brand Name	Motorola (Salom)	Model Name SC-25
	Power Rating	I/P: 100-240 Vac, 500mA, O/P: 5Vdc,3000mA or 9Vdc,1600mA or 12Vdc,1200mA	
AC Adapter 1(AU)	Brand Name	Motorola (Salom)	Model Name SC-26
	Power Rating	I/P: 100-240 Vac, 500mA, O/P: 5Vdc,3000mA or 9Vdc,1600mA or 12Vdc,1200mA	
AC Adapter 1 (Indonesia)	Brand Name	Motorola (Salom)	Model Name SC-23
	Power Rating	I/P: 100-240 Vac, 500mA, O/P: 5Vdc,3000mA or 9Vdc,1600mA or 12Vdc,1200mA	
AC Adapter 2(US)	Brand Name	Motorola (Chenyang)	Model Name SC-22
	Power Rating	I/P: 100-240 Vac, 500mA, O/P: 5Vdc,3000mA or 9Vdc,1600mA or 12Vdc,1200mA	
AC Adapter 2(EU)	Brand Name	Motorola (Chenyang)	Model Name SC-23
	Power Rating	I/P: 100-240 Vac, 500mA, O/P: 5Vdc,3000mA or 9Vdc,1600mA or 12Vdc,1200mA	
AC Adapter 2(UK)	Brand Name	Motorola (Chenyang)	Model Name SC-24
	Power Rating	I/P: 100-240 Vac, 500mA, O/P: 5Vdc,3000mA or 9Vdc,1600mA or 12Vdc,1200mA	
AC Adapter 2(IN)	Brand Name	Motorola (Chenyang)	Model Name SC-25
	Power Rating	I/P: 100-240 Vac, 500mA, O/P: 5Vdc,3000mA or 9Vdc,1600mA or 12Vdc,1200mA	
AC Adapter 2(AU)	Brand Name	Motorola (Chenyang)	Model Name SC-26
	Power Rating	I/P: 100-240 Vac, 500mA, O/P: 5Vdc,3000mA or 9Vdc,1600mA or 12Vdc,1200mA	
Battery	Brand Name	Motorola (ATL)	Model Name JT40
	Power Rating	3.8Vdc,3200mAh	Type Li-ion Polymer
Earphone 1	Brand Name	Motorola (Jiahe)	Model Name LS-118M-12
	Signal Line Type	1.2 meter, non-shielded cable, without ferrite core	
Earphone 2	Brand Name	Motorola (Lianyun)	Model Name TS910A-38AMS01WHR-M
	Signal Line Type	1.2 meter, non-shielded cable, without ferrite core	
USB Cable	Brand Name	Motorola (Liqi)	Model Name L32B-053000100-ALL
	Signal Line Type	1.0 meter, shielded cable, without ferrite core	



### 1.8 Testing Location

SPORTON INTERNATIONAL INC. is accredited to ISO 17025 by Taiwan Accreditation Foundation (TAF code : 1190) and the FCC designation No. TW1007 under the FCC-recognized accredited testing laboratories by Mutual Recognition Agreement (MRA) in FCC Test.

<b>Test Site</b>	SPORTON INTERNATIONAL INC.	
<b>Test Site Location</b>	No.58, Aly. 75, Ln. 564 Wenhua 3rd Rd. Guishan Dist. Taoyuan City Taiwan TEL: +886-3-327-3456 FAX: +886-3-328-4978	
<b>Test Site No.</b>	<b>Sporton Site No.</b>	<b>FCC Test Firm Registration No.</b>
	03CH12-HY	214511

**Note:** The test site complies with ANSI C63.4 2014 requirement.

### 1.9 Applicable Standards

According to the specifications of the manufacturer, the EUT must comply with the requirements of the following standards:

- ♦ FCC Part 15 Subpart C §15.247
- ♦ ANSI C63.10-2013

**Remark:**

1. All test items were verified and recorded according to the standards and without any deviation during the test.
2. This EUT has also been tested and complied with the requirements of FCC Part 15, Subpart B, recorded in a separate test report.



## 2 Test Configuration of Equipment Under Test

### 2.1 Test Mode

The following summary table is showing all test modes to demonstrate in compliance with the standard.

Summary table of Test Cases			
Test Item	Data Rate / Modulation		
	Bluetooth BR 1Mbps GFSK	Bluetooth EDR 2Mbps $\pi/4$ -DQPSK	Bluetooth EDR 3Mbps 8-DPSK
Radiated Test Cases	Bluetooth EDR 3Mbps 8-DPSK		
	Mode 1: CH00_2402 MHz		
	Mode 2: CH39_2441 MHz		
	Mode 3: CH78_2480 MHz		

## 2.2 Connection Diagram of Test System

<Bluetooth Tx Mode>

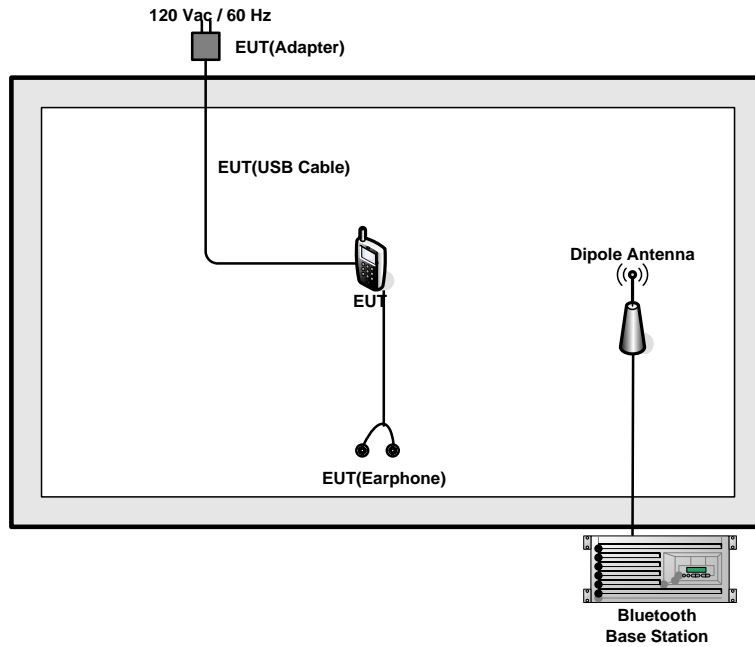

## 2.3 Support Unit used in test configuration and system

Item	Equipment	Trade Name	Model Name	FCC ID	Data Cable	Power Cord
1.	BT Base Station	R&S	CBT	N/A	N/A	Unshielded, 1.8 m

## 2.4 EUT Operation Test Setup

For Bluetooth function, the engineering test program was provided and enabled to make EUT connect with Bluetooth base station to continuous transmit/receive.



### 3 Test Result

#### 3.1 Radiated Band Edges and Spurious Emission Measurement

##### 3.1.1 Limit of Radiated Band Edges and Spurious Emission

In any 100 kHz bandwidth outside the intentional radiator frequency band, all harmonics/spurious must be at least 20 dB below the highest emission level within the authorized band. In addition, radiated emissions which fall in the restricted bands must also comply with the limits as below.

Frequency (MHz)	Field Strength (microvolts/meter)	Measurement Distance (meters)
0.009 – 0.490	2400/F(kHz)	300
0.490 – 1.705	24000/F(kHz)	30
1.705 – 30.0	30	30
30 – 88	100	3
88 – 216	150	3
216 - 960	200	3
Above 960	500	3

##### 3.1.2 Measuring Instruments

The measuring equipment is listed in the section 4 of this test report.



### 3.1.3 Test Procedures

1. The EUT was placed on a turntable with 0.8 meter for frequency below 1GHz and 1.5 meter for frequency above 1GHz respectively above ground.
2. The EUT was set 3 meters from the interference receiving antenna, which was mounted on the top of a variable height antenna tower.
3. For each suspected emission, the EUT was arranged to its worst case and then tune the Antenna tower (from 1 m to 4 m) and turntable (from 0 degree to 360 degrees) to find the maximum reading. A pre-amp and a high pass filter are used for the test in order to get better signal level to comply with the guidelines.
4. Set to the maximum power setting and enable the EUT transmit continuously.
5. Use the following spectrum analyzer settings:
  - (1) Span shall wide enough to fully capture the emission being measured;
  - (2) Set RBW=100 kHz for  $f < 1 \text{ GHz}$ , RBW=1MHz for  $f > 1\text{GHz}$  ; VBW  $\geq$  RBW; Sweep = auto; Detector function = peak; Trace = max hold for peak
  - (3) For average measurement: use duty cycle correction factor method per 15.35(c).  
Duty cycle = On time/100 milliseconds  
On time =  $N_1 * L_1 + N_2 * L_2 + \dots + N_{n-1} * L_{n-1} + N_n * L_n$   
Where  $N_1$  is number of type 1 pulses,  $L_1$  is length of type 1 pulses, etc.  
Average Emission Level = Peak Emission Level +  $20 * \log(\text{Duty cycle})$
6. Corrected Reading: Antenna Factor + Cable Loss + Read Level - Preamp Factor = Level

Note: The average levels were calculated from the peak level corrected with duty cycle correction factor (-24.75dB) derived from  $20 \log(\text{dwell time}/100\text{ms})$ . This correction is only for signals that hop with the fundamental signal, such as band-edge and harmonic. Other spurious signals that are independent of the hopping signal would not use this correction.

### 3.1.4 Test Setup

For radiated emissions below 30MHz

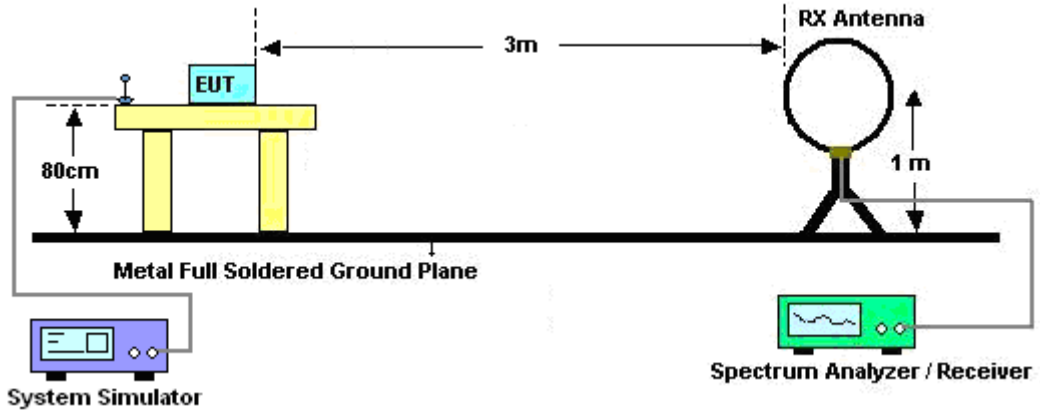

For radiated emissions from 30MHz to 1GHz

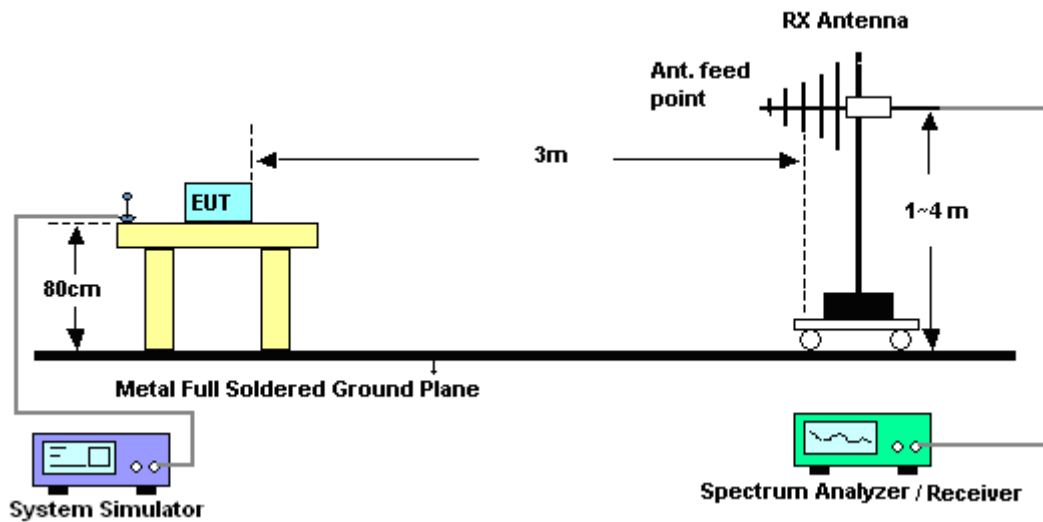

For radiated emissions above 1GHz

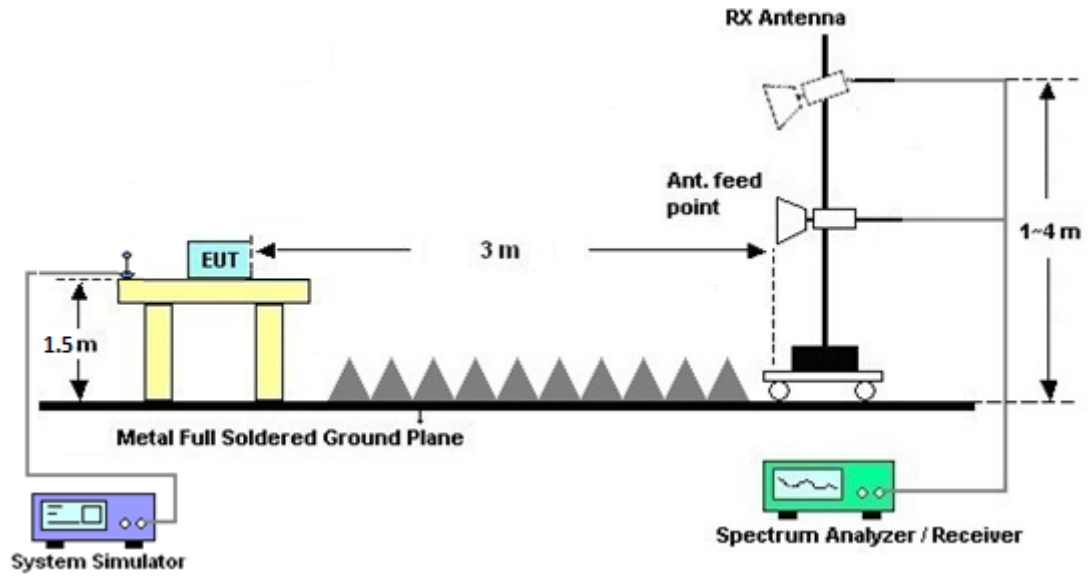

### 3.1.5 Test Results of Radiated Spurious Emissions (9 kHz ~ 30 MHz)

The low frequency, which started from 9 kHz to 30MHz, was pre-scanned and the result which was 20dB lower than the limit line was not reported.



### 3.1.6 Duty cycle correction factor for average measurement

#### DH5 on time (One Pulse) Plot on Channel 39

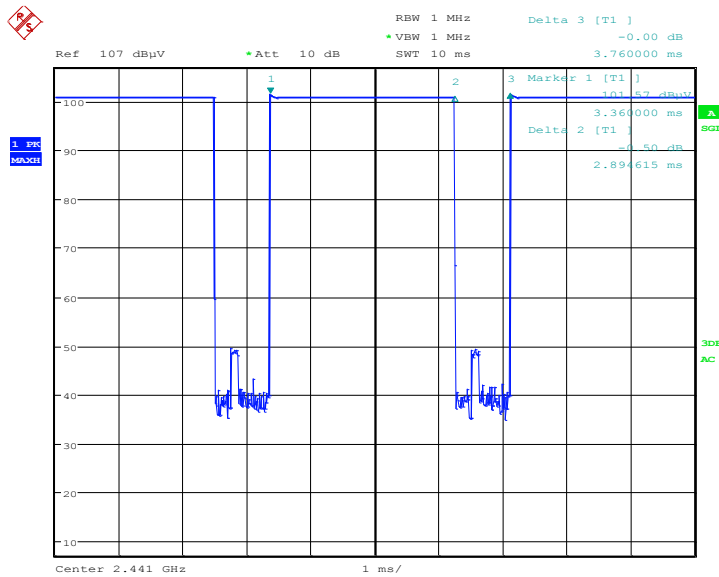

#### DH5 on time (Count Pulses) Plot on Channel 39

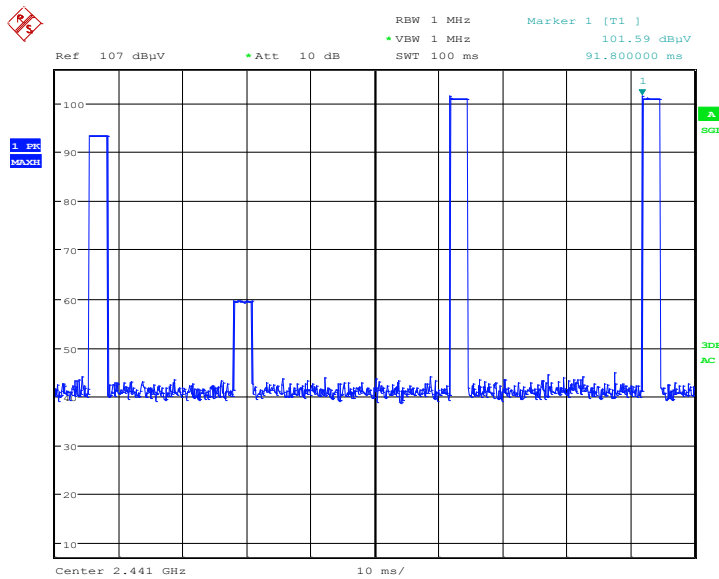

**Note:**

1. Worst case Duty cycle = on time/100 milliseconds = 2 \* 2.89 / 100 = 5.79 %
2. Worst case Duty cycle correction factor = 20\*log(Duty cycle) = -24.75 dB
3. DH5 has the highest duty cycle worst case and is reported.



**Duty Cycle Correction Factor Consideration for AFH mode:**

Bluetooth normal hopping rate is 1600Hz and reduced to 800Hz in AFH mode; due to the reduced number of hopping frequencies, with the same packet configuration the dwell time in each channel frequency within 100msec period is longer in AFH mode than normal mode.

In AFH mode, the minimum hopping frequencies are 20, to get the longest dwell time DH5 packet is observed; the period to have DH5 packet completing one hopping sequence is

$$2.89 \text{ ms} \times 20 \text{ channels} = 57.9 \text{ ms}$$

There cannot be 2 complete hopping sequences within 100ms period, considering the random hopping behavior, maximum 2 hops can be possibly observed within the period.  $[100\text{ms} / 57.9\text{ms}] = 2 \text{ hops}$

Thus, the maximum possible ON time:

$$2.89 \text{ ms} \times 2 = 5.79 \text{ ms}$$

Worst case Duty Cycle Correction factor, which is derived from the maximum possible ON time,

$$20 \times \log(5.79 \text{ ms}/100\text{ms}) = -24.75 \text{ dB}$$

**3.1.7 Test Result of Radiated Spurious at Band Edges**

Please refer to Appendix A.

**3.1.8 Test Result of Radiated Spurious Emission (30MHz ~ 10<sup>th</sup> Harmonic)**

Please refer to Appendix A.



## 4 List of Measuring Equipment

Instrument	Manufacturer	Model No.	Serial No.	Characteristics	Calibration Date	Test Date	Due Date	Remark
Amplifier	MITEQ	TTA1840-35-HG	1871923	18GHz~40GHz, VSWR : 2.5:1 max	Jul. 18, 2017	Feb. 09, 2018~ Feb. 13, 2018	Jul. 17, 2018	Radiation (03CH12-HY)
Bilog Antenna	TESEQ	CBL 6111D&N-6-06	35414&AT-N0602	30MHz~1GHz	Oct. 14, 2017	Feb. 09, 2018~ Feb. 13, 2018	Oct. 13, 2018	Radiation (03CH12-HY)
Loop Antenna	Rohde & Schwarz	HFH2-Z2	100488	9 kHz~30 MHz	Nov. 23, 2017	Feb. 09, 2018~ Feb. 13, 2018	Nov. 22, 2018	Radiation (03CH12-HY)
EMI Test Receiver	Rohde & Schwarz	ESU26	100390	20Hz~26.5GHz	Dec. 25, 2017	Feb. 09, 2018~ Feb. 13, 2018	Dec. 24, 2018	Radiation (03CH12-HY)
Horn Antenna	SCHWARZBECK	BBHA 9120D	9120D-1328	1GHz ~ 18GHz	Oct. 20, 2017	Feb. 09, 2018~ Feb. 13, 2018	Oct. 19, 2018	Radiation (03CH12-HY)
Hygrometer	TECPEL	DTM-303B	TP140349	N/A	Oct. 12, 2017	Feb. 09, 2018~ Feb. 13, 2018	Oct. 11, 2018	Radiation (03CH12-HY)
Preamplifier	COM-POWER	PA-103	161075	10MHz~1GHz	Mar. 23, 2017	Feb. 09, 2018~ Feb. 13, 2018	Mar. 22, 2018	Radiation (03CH12-HY)
Preamplifier	Keysight	83017A	MY53270148	1GHz~26.5GHz	Jan. 15, 2018	Feb. 09, 2018~ Feb. 13, 2018	Jan. 14, 2019	Radiation (03CH12-HY)
Filter	Wainwright	WLKS1200-12SS	SN2	1.2G Low Pass	Mar. 24, 2017	Feb. 09, 2018~ Feb. 13, 2018	Mar. 23, 2018	Radiation (03CH12-HY)
Controller	EMEC	EM1000	N/A	Control Turn table & Ant Mast	NCR	Feb. 09, 2018~ Feb. 13, 2018	NCR	Radiation (03CH12-HY)
Antenna Mast	EMEC	AM-BS-4500-B	N/A	1m~4m	NCR	Feb. 09, 2018~ Feb. 13, 2018	NCR	Radiation (03CH12-HY)
Turn Table	EMEC	TT2000	N/A	0~360 Degree	NCR	Feb. 09, 2018~ Feb. 13, 2018	NCR	Radiation (03CH12-HY)
SHF-EHF Horn Antenna	SCHWARZBECK	BBHA 9170	BBHA9170576	18GHz ~ 40GHz	Apr. 27, 2017	Feb. 09, 2018~ Feb. 13, 2018	Apr. 26, 2018	Radiation (03CH12-HY)
Spectrum Analyzer	Keysight	N9010A	MY55370526	10Hz~44GHz	Mar. 15, 2017	Feb. 09, 2018~ Feb. 13, 2018	Mar. 14, 2018	Radiation (03CH12-HY)

NCR: No Calibration Required



## 5 Uncertainty of Evaluation

### Uncertainty of Radiated Emission Measurement (30 MHz ~ 1000 MHz)

Measuring Uncertainty for a Level of Confidence of 95% ( $U = 2Uc(y)$ )	5.1dB
---	-------

### Uncertainty of Radiated Emission Measurement (1000 MHz ~ 18000 MHz)

Measuring Uncertainty for a Level of Confidence of 95% ( $U = 2Uc(y)$ )	5.2dB
---	-------

### Uncertainty of Radiated Emission Measurement (18000 MHz ~ 40000 MHz)

Measuring Uncertainty for a Level of Confidence of 95% ( $U = 2Uc(y)$ )	4.7dB
---	-------



## Appendix A. Radiated Spurious Emission

### 2.4GHz 2400~2483.5MHz

#### BT (Band Edge @ 3m)

BT	Note	Frequency	Level	Over Limit	Limit Line	Read Level	Antenna Factor	Path Loss	Preamp Factor	Ant Pos	Table Pos	Peak Avg.	Pol.
		( MHz )	( dBμV/m )	( dB )	( dBμV/m )	( dBμV )	( dB/m )	( dB )	( dB )	( cm )	( deg )	( P/A )	( H/V )
BT CH00 2402MHz		2311.68	43.8	-30.2	74	44.48	26.94	3.97	31.59	143	264	P	H
		2311.68	19.05	-34.95	54	-	-	-	-	-	-	A	H
	*	2402	103.31	-	-	103.69	27.15	4.04	31.57	143	264	P	H
	*	2402	78.56	-	-	-	-	-	-	-	-	A	H
		2338.77	44.27	-29.73	74	44.84	27.03	3.98	31.58	393	121	P	V
		2338.77	19.52	-34.48	54	-	-	-	-	-	-	A	V
	*	2402	101.18	-	-	101.56	27.15	4.04	31.57	393	121	P	V
	*	2402	76.43	-	-	-	-	-	-	-	-	A	V
BT CH 39 2441MHz		2318.4	43.95	-30.05	74	44.58	26.99	3.97	31.59	138	262	P	H
		2318.4	19.2	-34.8	54	-	-	-	-	-	-	A	H
	*	2441	103.51	-	-	103.72	27.28	4.07	31.56	138	262	P	H
	*	2441	78.76	-	-	-	-	-	-	-	-	A	H
		2497.48	44.12	-29.88	74	44.16	27.4	4.11	31.55	138	262	P	H
		2497.48	19.37	-34.63	54	-	-	-	-	-	-	A	H
		2377.2	43.66	-30.34	74	44.1	27.11	4.03	31.58	380	117	P	V
		2377.2	18.91	-35.09	54	-	-	-	-	-	-	A	V
	*	2441	101.44	-	-	101.65	27.28	4.07	31.56	380	117	P	V
	*	2441	76.69	-	-	-	-	-	-	-	-	A	V
		2488.31	43.97	-30.03	74	44.02	27.4	4.11	31.56	380	117	P	V
		2488.31	19.22	-34.78	54	-	-	-	-	-	-	A	V



BT CH 78 2480MHz	*	2480	105.52	-	-	105.63	27.36	4.09	31.56	111	263	P	H
	*	2480	80.77	-	-	-	-	-	-	-	-	A	H
		2483.52	55.25	-18.75	74	55.34	27.36	4.11	31.56	111	263	P	H
		2483.52	30.5	-23.5	54	-	-	-	-	-	-	A	H
	*	2480	103.03	-	-	103.14	27.36	4.09	31.56	370	120	P	V
	*	2480	78.28	-	-	-	-	-	-	-	-	A	V
		2483.72	51.47	-22.53	74	51.56	27.36	4.11	31.56	370	120	P	V
		2483.72	26.72	-27.28	54	-	-	-	-	-	-	A	V
<b>Remark</b>	<ol style="list-style-type: none"> <li>1. No other spurious found.</li> <li>2. All results are PASS against Peak and Average limit line.</li> </ol>												



**2.4GHz 2400~2483.5MHz**  
**BT (Harmonic @ 3m)**

BT	Note	Frequency ( MHz )	Level ( dBµV/m )	Over Limit ( dB )	Limit Line ( dBµV/m )	Read Level ( dBµV )	Antenna Factor ( dB/m )	Path Loss ( dB )	Preamp Factor ( dB )	Ant Pos ( cm )	Table Pos ( deg )	Peak Avg. ( P/A )	Pol. ( H/V )
BT CH 00 2402MHz		4804	39.3	-34.7	74	66.03	31.32	6.7	64.75	100	0	P	H
		4804	14.55	-39.45	54	-	-	-	-	-	-	A	H
		4804	38.71	-35.29	74	65.44	31.32	6.7	64.75	100	0	P	V
		4804	13.96	-40.04	54	-	-	-	-	-	-	A	V
BT CH 39 2441MHz		4882	39.57	-34.43	74	66.08	31.46	6.73	64.7	100	0	P	H
		4882	14.82	-39.18	54	-	-	-	-	-	-	A	H
		7323	44.22	-29.78	74	64.84	36.15	8.06	64.83	100	0	P	H
		7323	19.47	-34.53	54	-	-	-	-	-	-	A	H
		4882	39.32	-34.68	74	65.83	31.46	6.73	64.7	100	0	P	V
		4882	14.57	-39.43	54	-	-	-	-	-	-	A	V
		7323	44.31	-29.69	74	64.93	36.15	8.06	64.83	100	0	P	V
		7323	19.56	-34.44	54	-	-	-	-	-	-	A	V
BT CH 78 2480MHz		4960	39.26	-34.74	74	65.51	31.63	6.75	64.63	100	0	P	H
		4960	14.51	-39.49	54	-	-	-	-	-	-	A	H
		7440	44.03	-29.97	74	64.37	36.47	8.07	64.88	100	0	P	H
		7440	19.28	-34.72	54	-	-	-	-	-	-	A	H
		4960	39.93	-34.07	74	66.18	31.63	6.75	64.63	100	0	P	V
		4960	15.18	-38.82	54	-	-	-	-	-	-	A	V
		7440	44.07	-29.93	74	64.41	36.47	8.07	64.88	100	0	P	V
		7440	19.32	-34.68	54	-	-	-	-	-	-	A	V
<b>Remark</b>	1. No other spurious found. 2. All results are PASS against Peak and Average limit line.												



Emission below 1GHz

2.4GHz BT (LF)

BT	Note	Frequency	Level	Over	Limit	Read	Antenna	Path	Preamp	Ant	Table	Peak	Pol.
		( MHz )	( dBμV/m )	( dB )	( dBμV/m )	( dBμV )	( dB/m )	( dB )	( dB )	( cm )	( deg )	( P/A )	( H/V )
2.4GHz BT LF		101.82	19.42	-24.08	43.5	32.99	15.98	0.85	30.4	-	-	P	H
		178.5	26.13	-17.37	43.5	40.34	14.83	1.26	30.3	-	-	P	H
		290.82	21.77	-24.23	46	31.54	18.88	1.5	30.15	-	-	P	H
		568.1	27.86	-18.14	46	29.73	25.8	2.03	29.7	-	-	P	H
		934.2	33.86	-12.14	46	30.42	29.84	2.69	29.09	100	0	P	H
		967.1	35.08	-18.92	54	30.26	31.11	2.74	29.03	-	-	P	H
		34.59	30.75	-9.25	40	38.71	21.84	0.45	30.25	100	0	P	V
		184.44	21.67	-21.83	43.5	36.04	14.62	1.3	30.29	-	-	P	V
		293.52	20.72	-25.28	46	30.42	18.95	1.5	30.15	-	-	P	V
		437.2	26.59	-19.41	46	31.99	22.75	1.76	29.91	-	-	P	V
		874	31.95	-14.05	46	29.54	29.09	2.53	29.21	-	-	P	V
		968.5	34.56	-19.44	54	29.73	31.11	2.74	29.02	-	-	P	V
Remark	1. No other spurious found. 2. All results are PASS against limit line.												



**Note symbol**

*	<b>Fundamental Frequency</b> which can be ignored. However, the level of any unwanted emissions shall not exceed the level of the fundamental frequency.
!	Test result is <b>over limit</b> line.
P/A	<b>Peak</b> or <b>Average</b>
H/V	<b>Horizontal</b> or <b>Vertical</b>



A calculation example for radiated spurious emission is shown as below:

BT	Note	Frequency	Level	Over	Limit	Read	Antenna	Path	Preamp	Ant	Table	Peak	Pol.
		( MHz )	( dBμV/m )	( dB )	( dBμV/m )	( dBμV )	( dB/m )	( dB )	( dB )	( cm )	( deg )	( P/A )	( H/V )
BT CH 00 2402MHz		2390	55.45	-18.55	74	54.51	32.22	4.58	35.86	103	308	P	H
		2390	43.54	-10.46	54	42.6	32.22	4.58	35.86	103	308	A	H

1. Path Loss(dB) = Cable loss(dB) + Filter loss(dB) + Attenuator loss(dB)
2. Level(dBμV/m) =  
Antenna Factor(dB/m) + Path Loss(dB) + Read Level(dBμV) - Preamp Factor(dB)
3. Over Limit(dB) = Level(dBμV/m) – Limit Line(dBμV/m)

**For Peak Limit @ 2390MHz:**

1. Level(dBμV/m)  
= Antenna Factor(dB/m) + Path Loss(dB) + Read Level(dBμV) - Preamp Factor(dB)  
= 32.22(dB/m) + 4.58(dB) + 54.51(dBμV) – 35.86 (dB)  
= 55.45 (dBμV/m)
2. Over Limit(dB)  
= Level(dBμV/m) – Limit Line(dBμV/m)  
= 55.45(dBμV/m) – 74(dBμV/m)  
= -18.55(dB)

**For Average Limit @ 2390MHz:**

1. Level(dBμV/m)  
= Antenna Factor(dB/m) + Path Loss(dB) + Read Level(dBμV) - Preamp Factor(dB)  
= 32.22(dB/m) + 4.58(dB) + 42.6(dBμV) – 35.86 (dB)  
= 43.54 (dBμV/m)
2. Over Limit(dB)  
= Level(dBμV/m) – Limit Line(dBμV/m)  
= 43.54(dBμV/m) – 54(dBμV/m)  
= -10.46(dB)

**Both peak and average measured complies with the limit line, so test result is “PASS”.**



## **Appendix C. Reference Report**

Please refer to Sporton report number FR7D2702A which is issued separately.