



FCC RF Test Report

APPLICANT : Motorola Mobility LLC
EQUIPMENT : Mobile Cellular Phone
BRAND NAME : Motorola
MODEL NAME : 10873
FCC ID : IHDT56WK2
STANDARD : 47 CFR Part 2, 22(H), 24(E), 27(L), 27(M)
CLASSIFICATION : PCS Licensed Transmitter Held to Ear (PCE)

The product was received on Jun. 17, 2017 and completely tested on Aug. 03, 2017. We, Sporton International (Kunshan) Inc., would like to declare that the tested sample has been evaluated in accordance with the test procedures given in ANSI / TIA / EIA-603-D-2010 and the testing has shown the tested sample to be in compliance with the applicable technical standards.

The test results in this report apply exclusively to the tested model / sample. Without written approval of Sporton International (Kunshan) Inc., the test report shall not be reproduced except in full.



Approved by: James Huang / Manager

Sporton International (Kunshan) Inc.
No.3-2 Ping-Xiang Rd, Kunshan Development Zone Kunshan City Jiangsu Province 215335
China



TABLE OF CONTENTS

REVISION HISTORY...3
SUMMARY OF TEST RESULT...4
1 GENERAL DESCRIPTION...5
1.1 Applicant...5
1.2 Manufacturer...5
1.3 Product Feature of Equipment Under Test...5
1.4 Product Specification of Equipment Under Test...6
1.5 Specification of Accessory...7
1.6 Modification of EUT...7
1.7 Re-use of Measured Data...8
1.8 Maximum EIRP Power, Frequency Tolerance, and Emission Designator...9
1.9 Testing Location...11
1.10 Applicable Standards...11
2 TEST CONFIGURATION OF EQUIPMENT UNDER TEST...12
2.1 Test Mode...12
2.2 Connection Diagram of Test System...14
2.3 Support Unit used in test configuration and system...14
2.4 Measurement Results Explanation Example...14
2.5 Frequency List of Low/Middle/High Channels...15
3 CONDUCTED TEST ITEMS...17
3.1 Measuring Instruments...17
3.2 Test Setup...17
3.3 Test Result of Conducted Test...17
3.4 Conducted Output Power and EIRP...18
3.5 Peak-to-Average Ratio...19
3.6 Occupied Bandwidth...20
3.7 Conducted Band Edge...21
3.8 Conducted Spurious Emission...23
3.9 Frequency Stability...24
4 RADIATED TEST ITEMS...25
4.1 Measuring Instruments...25
4.2 Test Setup...25
4.3 Test Result of Radiated Test...25
4.4 Radiated Spurious Emission...26
5 LIST OF MEASURING EQUIPMENT...27
6 UNCERTAINTY OF EVALUATION...28
APPENDIX A. TEST RESULTS OF CONDUCTED TEST
APPENDIX B. TEST RESULTS OF RADIATED TEST
APPENDIX C. TEST SETUP PHOTOGRAPHS
APPENDIX D. REFERENCE REPORT



SUMMARY OF TEST RESULT

Report Section	FCC Rule	Description	Limit	Result	Remark
3.4	§2.1046	Conducted Output Power	Reporting Only	PASS	-
	§24.232(c) §27.50(h)(2)	Equivalent Isotropic Radiated Power (Band 2) (Band 41)	EIRP < 2Watt	PASS	-
	§27.50(d)(4)	Equivalent Isotropic Radiated Power (Band 4)	EIRP < 1Watt	PASS	-
3.5	§24.232(d)	Peak-to-Average Ratio	<13 dB	PASS	-
3.6	§2.1049	Occupied Bandwidth	Reporting Only	PASS	-
3.7	§2.1051 §22.917(a) §24.238(a)	Conducted Band Edge Measurement (Band 2) (Band 4))	< 43+10log ₁₀ (P[Watts])	PASS	-
	§27.53(m)(4)	Conducted Band Edge Measurement (Band 41)	§27.53(m)(4)		
3.8	§2.1051 §22.917(a) §24.238(a)	Conducted Spurious Emission (Band 2) (Band 4)	< 43+10log ₁₀ (P[Watts])	PASS	-
	§2.1051 §27.53(m)(4)	Conducted Spurious Emission (Band 41)	< 55+10log ₁₀ (P[Watts])		
3.9	§2.1055 §24.235 §27.54	Frequency Stability Temperature & Voltage	Within Authorized Band	PASS	-
4.4	§2.1053 §22.917(a) §24.238(a) §27.53(h)	Radiated Spurious Emission (Band 2) (Band 4)	< 43+10log ₁₀ (P[Watts])	PASS	Under limit 24.35 dB at 5193.000 MHz
	§2.1053 §27.53(m)(4)	Radiated Spurious Emission (Band 41)	< 55+10log ₁₀ (P[Watts])		



1 General Description

1.1 Applicant

Motorola Mobility LLC
222 W, Merchandise Mart Plaza, Chicago IL 60654 USA

1.2 Manufacturer

Motorola Mobility LLC
222 W, Merchandise Mart Plaza, Chicago IL 60654 USA

1.3 Product Feature of Equipment Under Test

Product Feature	
Equipment	Mobile Cellular Phone
Brand Name	Motorola
Model Name	10873
FCC ID	IHDT56WK2
EUT supports Radios application	GSM/GPRS/EGPRS/WCDMA/HSPA/ HSPA+(16QAM uplink is not supported)/DC-HSDPA/LTE/NFC WLAN2.4GHz 802.11b/g/n HT20/HT40 WLAN5GHz 802.11a/n HT20/HT40/ WLAN5GHz 802.11ac VHT20/VHT40/VHT80 Bluetooth v3.0 + EDR/Bluetooth v4.0 LE Bluetooth v4.1 LE/ Bluetooth v4.2 LE/ Bluetooth v5.0 LE
IMEI Code	Conudcted: 351899080032337/351899080032345 Radiation: 351899080031891/351899080031909
HW Version	DVT2
SW Version	NPW26.75
EUT Stage	Identical Prototype



1.4 Product Specification of Equipment Under Test

Standards-related Product Specification	
Tx Frequency	LTE Band 2 : 1850.7 MHz ~ 1909.3 MHz LTE Band 4 : 1710.7 MHz ~ 1754.3 MHz LTE Band 5 : 824.7 MHz ~ 848.3 MHz LTE Band 7 : 2502.5 MHz ~ 2567.5 MHz LTE Band 26 : 824.7MHz ~ 848.3 MHz LTE Band 38 : 2572.5MHz ~ 2617.5MHz LTE Band 41 : 2498.5 MHz ~ 2687.5 MHz
Rx Frequency	LTE Band 2 : 1930.7 MHz ~ 1989.3 MHz LTE Band 4 : 2110.7 MHz ~ 2154.3 MHz LTE Band 5 : 869.7 MHz ~ 893.3 MHz LTE Band 7 : 2622.5MHz ~ 2687.5 MHz LTE Band 26 : 869.7MHz ~ 893.3MHz LTE Band 38 : 2572.5MHz ~ 2617.5MHz LTE Band 41 : 2498.5 MHz ~ 2687.5 MHz
Bandwidth	LTE Band 2 : 1.4MHz / 3MHz / 5MHz / 10MHz / 15MHz / 20MHz LTE Band 4 : 1.4MHz / 3MHz / 5MHz / 10MHz / 15MHz / 20MHz LTE Band 5 : 1.4MHz / 3MHz / 5MHz / 10MHz LTE Band 7 : 5MHz / 10MHz / 15MHz / 20MHz LTE Band 26 : 1.4MHz / 3MHz / 5MHz / 10MHz / 15MHz LTE Band 38 : 5MHz / 10MHz / 15MHz / 20MHz LTE Band 41 : 5MHz / 10MHz / 15MHz / 20MHz
Maximum Output Power to Antenna	LTE Band 2 : 23.05 dBm LTE Band 4 : 23.12 dBm LTE Band 41 : 23.34 dBm
Antenna Gain	LTE Band 2 : -1.60 dBi LTE Band 4 : -0.90 dBi LTE Band 41 : 2.80 dBi
Type of Modulation	QPSK / 16QAM / 64QAM

1.5 Specification of Accessory

Specification of Accessory				
AC Adapter 1 (US)	Brand Name	Motorola (Salom)	Model Name	SC-22
	Power Rating	I/P: 100 - 240 Vac, 500 mA, O/P: 5/9/12 Vdc, 3000/1600/1200 mA		
AC Adapter 2 (US)	Brand Name	Motorola (Chenyang)	Model Name	SC-22
	Power Rating	I/P: 100 - 240 Vac, 500 mA, O/P: 5/9/12 Vdc, 3000/1600/1200 mA		
AC Adapter 3 (US)	Brand Name	Motorola (LiteOn)	Model Name	SC-22
	Power Rating	I/P: 100 - 240 Vac, 500 mA, O/P: 5/9/12 Vdc, 3000/1600/1200 mA		
Battery	Brand Name	Motorola (Sunwoda)	Model Name	HX40
	Power Rating	3.8Vdc, 2810mAh	Type	Li-ion
Earphone	Brand Name	Motorola (Cosonic)	Model Name	SH38C16617
	Signal Line Type	1.10 meter, non-shielded cable, without ferrite core		
USB Cable 1	Brand Name	Motorola (Saibao)	Model Name	SKN6473A
	Signal Line Type	1.10 meter, shielded cable, without ferrite core		
USB Cable 2	Brand Name	Motorola (Foxlink)	Model Name	SKN6473A
	Signal Line Type	1.10 meter, shielded cable, without ferrite core		
USB Cable 3	Brand Name	Motorola (Cabletech)	Model Name	SKN6473A
	Signal Line Type	1.10 meter, shielded cable, without ferrite core		

1.6 Modification of EUT

No modifications are made to the EUT during all test items.



1.7 Re-use of Measured Data

1.7.1 Introduction Section

This application re-uses data collected on a similar device. The subject device of this application (Model: 10873, FCC ID: IHDT56WK2) is electrically identical to the reference device (Model: 10647, FCC ID: IHDT56WK1) for the portions of the circuitry corresponding to the data being re-used, as treated by KDB Publication 178919 D01.

1.7.2 Difference Section

For details concerning the similarity with respect to component placement, mechanical/electrical design etc., some difference of population/depopulation to enable support of different cellular bands, please refer to the Operational Description.

The re-used RF data includes the following bands provided in Appendix D (Sporton RF Report No. FG761702-01A for the reference device Model: 10647, FCC ID: IHDT56WK1):

1.7.3 Spot Check Verification Data Section

In order to confirm hardware similarity of the subject device with the reference device, spot check measurements were performed on the subject device for radiated spurious emission, the test result were consistent with FCC ID: IHDT56WK1 and LTE Band 2/4/41 to re-test.

Assertions concerning the similarity of these devices are based on representations by the applicant. The applicant accepts full responsibility for the validity of the similarity claim, and for the determination that verification test data are sufficient to support it.

1.7.4 Reference detail Section:

Equipment Class	Reference FCC ID	Folder Test/RF Exposure	Report Title/Section
PCE (2G)	IHDT56WK1	Part22H.24E.27L (FG761702-01A)	GSM850, PCS1900, WCDMA Band V
PCE (LTE)	IHDT56WK1	Part22H.24E.27L.27M.27H (FG761702-01B)	LTE band 5/7/26/38



1.8 Maximum EIRP Power, Frequency Tolerance, and Emission Designator

LTE Band 2		QPSK			16QAM		
BW (MHz)	Frequency Range (MHz)	Emission Designator (99%OBW)	Frequency Tolerance (ppm)	Maximum EIRP(W)	Emission Designator (99%OBW)	Frequency Tolerance (ppm)	Maximum EIRP(W)
1.4	1850.7 ~ 1909.3	1M10G7D	-	0.1355	1M09W7D	-	0.1148
3	1851.5 ~ 1908.5	2M74G7D	-	0.1377	2M75W7D	-	0.1169
5	1852.5 ~ 1907.5	4M49G7D	-	0.1368	4M51W7D	-	0.1169
10	1855.0 ~ 1905.0	9M09G7D	0.0029	0.1368	9M05W7D	-	0.1161
15	1857.5 ~ 1902.5	13M4G7D	-	0.1396	13M6W7D	-	0.1202
20	1860.0 ~ 1900.0	18M4G7D	-	0.1374	18M4W7D	-	0.1189
LTE Band 2		64QAM					
BW (MHz)	Frequency Range (MHz)	Emission Designator (99%OBW)		Frequency Tolerance (ppm)	Maximum EIRP(W)		
1.4	1850.7 ~ 1909.3	1M09W7D		-	0.1119		
3	1851.5 ~ 1908.5	2M75W7D		-	0.1130		
5	1852.5 ~ 1907.5	4M50W7D		-	0.1117		
10	1855.0 ~ 1905.0	9M09W7D		-	0.1135		
15	1857.5 ~ 1902.5	13M5W7D		-	0.1161		
20	1860.0 ~ 1900.0	18M4W7D		-	0.1143		
LTE Band 4		QPSK			16QAM		
BW (MHz)	Frequency Range (MHz)	Emission Designator (99%OBW)	Frequency Tolerance (ppm)	Maximum EIRP(W)	Emission Designator (99%OBW)	Frequency Tolerance (ppm)	Maximum EIRP(W)
1.4	1710.7 ~ 1754.3	1M09G7D	-	0.1600	1M09W7D	-	0.1355
3	1711.5 ~ 1753.5	2M72G7D	-	0.1626	2M73W7D	-	0.1384
5	1712.5 ~ 1752.5	4M52G7D	-	0.1618	4M50W7D	-	0.1371
10	1715.0 ~ 1750.0	9M07G7D	0.0032	0.1637	9M05W7D	-	0.1406
15	1717.5 ~ 1747.5	13M4G7D	-	0.1641	13M5W7D	-	0.1409
20	1720.0 ~ 1745.0	18M4G7D	-	0.1667	18M5W7D	-	0.1413



LTE Band 4		64QAM					
BW (MHz)	Frequency Range (MHz)	Emission Designator (99%OBW)	Frequency Tolerance (ppm)	Maximum EIRP(W)			
1.4	1710.7 ~ 1754.3	1M09W7D	-	0.1321			
3	1711.5 ~ 1753.5	2M74W7D	-	0.1334			
5	1712.5 ~ 1752.5	4M50W7D	-	0.1330			
10	1715.0 ~ 1750.0	9M07W7D	-	0.1355			
15	1717.5 ~ 1747.5	13M5W7D	-	0.1355			
20	1720.0 ~ 1745.0	18M4W7D	-	0.1380			
LTE Band 41		QPSK			16QAM		
BW (MHz)	Frequency Range (MHz)	Emission Designator (99%OBW)	Frequency Tolerance (ppm)	Maximum EIRP(W)	Emission Designator (99%OBW)	Frequency Tolerance (ppm)	Maximum EIRP(W)
5	2498.5 ~ 2687.5	4M50G7D	-	0.4027	4M52W7D	-	0.3311
10	2501.0 ~ 2685.0	9M11G7D	0.0025	0.4093	9M05W7D	-	0.3319
15	2503.5 ~ 2682.5	13M5G7D	-	0.4046	13M5W7D	-	0.3281
20	2506.0 ~ 2680.0	18M3G7D	-	0.4111	18M3W7D	-	0.3319
LTE Band 41		64QAM					
BW (MHz)	Frequency Range (MHz)	Emission Designator (99%OBW)	Frequency Tolerance (ppm)	Maximum EIRP(W)			
5	2498.5 ~ 2687.5	4M50W7D	-	0.3090			
10	2501.0 ~ 2685.0	9M01W7D	-	0.3105			
15	2503.5 ~ 2682.5	13M5W7D	-	0.3090			
20	2506.0 ~ 2680.0	18M5W7D	-	0.3133			



1.9 Testing Location

Sporton Lab is accredited to ISO 17025 by National Voluntary Laboratory Accreditation Program (NVLAP code: 600155-0) and the FCC designation No is CN5013.

Test Site	Sporton International (Kunshan) Inc.		
Test Site Location	No.3-2 Ping-Xiang Rd, Kunshan Development Zone Kunshan City Jiangsu Province 215335 China TEL : +86-512-57900158 FAX : +86-512-57900958		
Test Site No.	Sporton Site No.		FCC Test Firm Registration No.
	TH01-KS	03CH03-KS	630927

Note: The test site complies with ANSI C63.4 2014 requirement.

1.10 Applicable Standards

According to the specifications of the manufacturer, the EUT must comply with the requirements of the following standards:

- ♦ 47 CFR Part 2, 22(H), 24(E), 27(L), 27(M)
- ♦ ANSI / TIA / EIA-603-D-2010
- ♦ FCC KDB 971168 D01 Power Meas. License Digital Systems v02r02
- ♦ FCC KDB 412172 D01 Determining ERP and EIRP v01r01

Remark:

1. All test items were verified and recorded according to the standards and without any deviation during the test.
2. This EUT has also been tested and complied with the requirements of FCC Part 15, Subpart B, recorded in a separate test report.



2 Test Configuration of Equipment Under Test

2.1 Test Mode

Antenna port conducted and radiated test items listed below are performed according to KDB 971168 D01 Power Meas. License Digital Systems v02r02 with maximum output power.

Radiated measurements are performed by rotating the EUT in three different orthogonal test planes to find the maximum emission.

Test Items	Band	Bandwidth (MHz)						Modulation			RB #			Test Channel		
		1.4	3	5	10	15	20	QPSK	16QAM	64QAM	1	Half	Full	L	M	H
Max. Output Power	2	Y	Y	Y	Y	Y	Y	Y	Y	Y	Y	Y	Y	Y	Y	Y
	4	Y	Y	Y	Y	Y	Y	Y	Y	Y	Y	Y	Y	Y	Y	Y
	41	-	-	Y	Y	Y	Y	Y	Y	Y	Y	Y	Y	Y	Y	Y
Peak-to-Average Ratio	2						Y	Y	Y	Y	Y		Y	Y	Y	Y
	4						Y	Y	Y	Y	Y		Y	Y	Y	Y
	41	-	-				Y	Y	Y	Y	Y		Y	Y	Y	Y
26dB and 99% Bandwidth	2	Y	Y	Y	Y	Y	Y	Y	Y	Y			Y	Y	Y	Y
	4	Y	Y	Y	Y	Y	Y	Y	Y	Y			Y	Y	Y	Y
	41	-	-	Y	Y	Y	Y	Y	Y	Y			Y	Y	Y	Y
Conducted Band Edge	2	Y	Y	Y	Y	Y	Y	Y	Y	Y	Y		Y	Y		Y
	4	Y	Y	Y	Y	Y	Y	Y	Y	Y	Y		Y	Y		Y
	41	-	-	Y	Y	Y	Y	Y	Y	Y	Y		Y	Y		Y
Conducted Spurious Emission	2	Y	Y	Y	Y	Y	Y	Y	Y	Y	Y			Y	Y	Y
	4	Y	Y	Y	Y	Y	Y	Y	Y	Y	Y			Y	Y	Y
	41	-	-	Y	Y	Y	Y	Y	Y	Y	Y			Y	Y	Y
Frequency Stability	2				Y			Y					Y		Y	
	4				Y			Y					Y		Y	
	41	-	-		Y			Y					Y		Y	



Test Items	Band	Bandwidth (MHz)						Modulation			RB #			Test Channel		
		1.4	3	5	10	15	20	QPSK	16QAM	64QAM	1	Half	Full	L	M	H
E.I.R.P.	2	v	v	v	v	v	v	v	v	v	v			v	v	v
	4	v	v	v	v	v	v	v	v	v	v			v	v	v
	41	-	-	v	v	v	v	v	v	v	v			v	v	v
Radiated Spurious Emission	2	v	v	v	v	v	v	-			-				v	
	4	v	v	v	v	v	v	-			-				v	
	41	-	-	v	v	v	v	v			v				v	
Note	<p>1. The mark "v" means that this configuration is chosen for testing</p> <p>2. The mark "-" means that this bandwidth is not supported.</p> <p>3. The device is investigated from 30MHz to 10 times of fundamental signal for radiated spurious emission test under different RB size/offset and modulations in exploratory test. Subsequently, only the worst case emissions are reported.</p>															

2.2 Connection Diagram of Test System

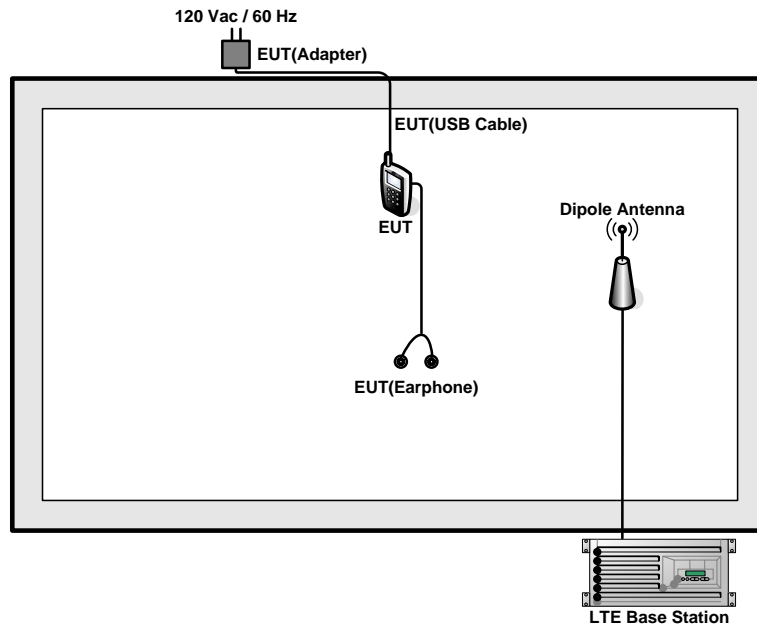

2.3 Support Unit used in test configuration and system

Item	Equipment	Trade Name	Model No.	FCC ID	Data Cable	Power Cord
1.	LTE Base Station	Anritsu	MT8820C	N/A	N/A	Unshielded, 1.8 m
2.	DC Power Supply	GW	GPS-3030D	N/A	N/A	Unshielded, 1.8 m

2.4 Measurement Results Explanation Example

For all conducted test items:

The offset level is set in the spectrum analyzer to compensate the RF cable loss between EUT conducted output port and spectrum analyzer. With the offset compensation, the spectrum analyzer reading level is exactly the EUT RF output level.

The spectrum analyzer offset is derived from RF cable loss.

Offset = RF cable loss.

Following shows an offset computation example with cable loss 5.1 dB.

Example :

$$\begin{aligned} \text{Offset(dB)} &= \text{RF cable loss(dB)}. \\ &= 5.1 \text{ (dB)} \end{aligned}$$



2.5 Frequency List of Low/Middle/High Channels

LTE Band 2 Channel and Frequency List				
BW [MHz]	Channel/Frequency(MHz)	Lowest	Middle	Highest
20	Channel	18700	18900	19100
	Frequency	1860	1880	1900
15	Channel	18675	18900	19125
	Frequency	1857.5	1880	1902.5
10	Channel	18650	18900	19150
	Frequency	1855	1880	1905
5	Channel	18625	18900	19175
	Frequency	1852.5	1880	1907.5
3	Channel	18615	18900	19185
	Frequency	1851.5	1880	1908.5
1.4	Channel	18607	18900	19193
	Frequency	1850.7	1880	1909.3

LTE Band 4 Channel and Frequency List				
BW [MHz]	Channel/Frequency(MHz)	Lowest	Middle	Highest
20	Channel	20050	20175	20300
	Frequency	1720	1732.5	1745
15	Channel	20025	20175	20325
	Frequency	1717.5	1732.5	1747.5
10	Channel	20000	20175	20350
	Frequency	1715	1732.5	1750
5	Channel	19975	20175	20375
	Frequency	1712.5	1732.5	1752.5
3	Channel	19965	20175	20385
	Frequency	1711.5	1732.5	1753.5
1.4	Channel	19957	20175	20393
	Frequency	1710.7	1732.5	1754.3



LTE Band 41 Channel and Frequency List				
BW [MHz]	Channel/Frequency(MHz)	Lowest	Middle	Highest
20	Channel	39750	40620	41490
	Frequency	2506	2593	2680
15	Channel	39725	40620	41515
	Frequency	2503.5	2593	2682.5
10	Channel	39700	40620	41540
	Frequency	2501	2593	2685
5	Channel	39675	40620	41565
	Frequency	2498.5	2593	2687.5

3 Conducted Test Items

3.1 Measuring Instruments

See list of measuring instruments of this test report.

3.2 Test Setup

3.2.1 Conducted Output Power

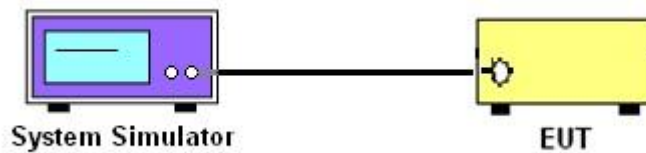

3.2.2 Peak-to-Average Ratio, Occupied Bandwidth ,Conducted Band-Edge and Conducted Spurious Emission

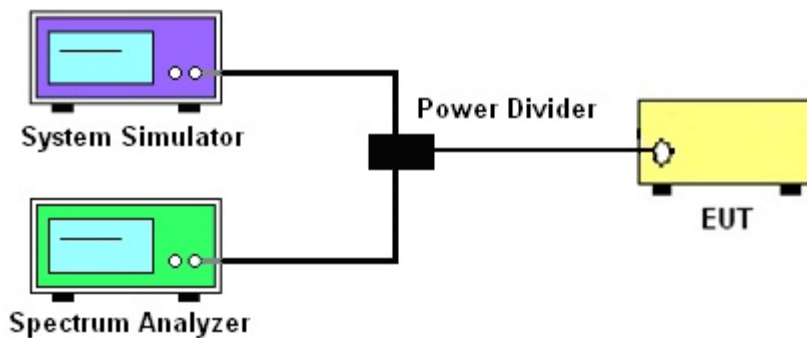

3.2.3 Frequency Stability

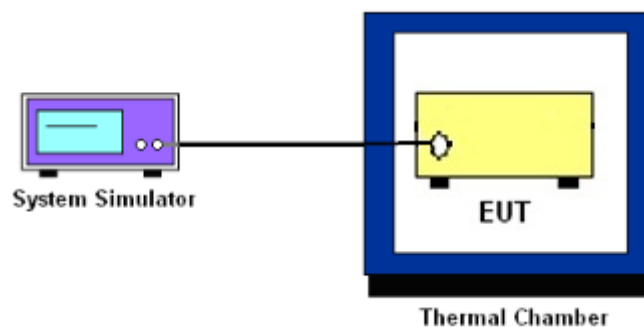

3.3 Test Result of Conducted Test

Please refer to Appendix A.



3.4 Conducted Output Power and EIRP

3.4.1 Description of the Conducted Output Power Measurement and EIRP Measurement

A system simulator was used to establish communication with the EUT. Its parameters were set to force the EUT transmitting at maximum output power. The measured power in the radio frequency on the transmitter output terminals shall be reported.

The EIRP of mobile transmitters must not exceed 2 Watts for LTE Band 2 and Band 41.

The EIRP of mobile transmitters must not exceed 1 Watts for LTE Band 4.

According to KDB 412172 D01 Power Approach,

$EIRP = P_T + G_T - L_C$, $ERP = EIRP - 2.15$, where

P_T = transmitter output power in dBm

G_T = gain of the transmitting antenna in dBi

L_C = signal attenuation in the connecting cable between the transmitter and antenna in dB

3.4.2 Test Procedures

1. The transmitter output port was connected to the system simulator.
2. Set EUT at maximum power through the system simulator.
3. Select lowest, middle, and highest channels for each band and different modulation.
4. Measure and record the power level from the system simulator.



3.5 Peak-to-Average Ratio

3.5.1 Description of the PAR Measurement

Power Complementary Cumulative Distribution Function (CCDF) curves provide a means for characterizing the power peaks of a digitally modulated signal on a statistical basis. A CCDF curve depicts the probability of the peak signal amplitude exceeding the average power level. Most contemporary measurement instrumentation include the capability to produce CCDF curves for an input signal provided that the instrument's resolution bandwidth can be set wide enough to accommodate the entire input signal bandwidth. In measuring transmissions in this band using an average power technique, the peak-to-average ratio (PAR) of the transmission may not exceed 13 dB.

3.5.2 Test Procedures

1. The testing follows FCC KDB 971168 v02r02 Section 5.7.1.
2. The EUT was connected to spectrum and system simulator via a power divider.
3. Set the CCDF (Complementary Cumulative Distribution Function) option in spectrum analyzer.
4. The highest RF powers were measured and recorded the maximum PAPR level associated with a probability of 0.1 %.
5. Record the deviation as Peak to Average Ratio.



3.6 Occupied Bandwidth

3.6.1 Description of Occupied Bandwidth Measurement

The occupied bandwidth is the width of a frequency band such that, below the lower and above the upper frequency limits, the mean powers emitted are each equal to a specified percentage 0.5% of the total mean transmitted power.

The 26 dB emission bandwidth is defined as the frequency range between two points, one above and one below the carrier frequency, at which the spectral density of the emission is attenuated 26 dB below the maximum in-band spectral density of the modulated signal. Spectral density (power per unit bandwidth) is to be measured with a detector of resolution bandwidth equal to approximately 1.0% of the emission bandwidth.

3.6.2 Test Procedures

1. The testing follows FCC KDB 971168 v02r02 Section 4.1 and 4.2.
2. The EUT was connected to spectrum analyzer and system simulator via a power divider.
3. The spectrum analyzer center frequency is set to the nominal EUT channel center frequency. The span range for the spectrum analyzer shall be between two and five times the anticipated OBW.
4. The nominal resolution bandwidth (RBW) shall be in the range of 1 to 5 % of the anticipated OBW, and the VBW shall be at least 3 times the RBW.
5. Set the detection mode to peak, and the trace mode to max hold.
6. Determine the reference value: Set the EUT to transmit a modulated signal. Allow the trace to stabilize. Set the spectrum analyzer marker to the highest level of the displayed trace.
(this is the reference value)
7. Determine the “-26 dB down amplitude” as equal to (Reference Value – X).
8. Place two markers, one at the lowest and the other at the highest frequency of the envelope of the spectral display such that each marker is at or slightly below the “-X dB down amplitude” determined in step 6. If a marker is below this “-X dB down amplitude” value it shall be placed as close as possible to this value. The OBW is the positive frequency difference between the two markers.
9. Use the 99 % power bandwidth function of the spectrum analyzer and report the measured bandwidth.



3.7 Conducted Band Edge

3.7.1 Description of Conducted Band Edge Measurement

24.238 (a)

For operations in the 1850-1910 and 1930-1990 MHz band, the FCC limit is $43 + 10\log_{10}(P[\text{Watts}])$ dB below the transmitter power $P(\text{Watts})$ in a 1MHz bandwidth. However, in the 1 MHz bands immediately outside and adjacent to the frequency block a resolution bandwidth of at least one percent of the emission bandwidth of the fundamental emission of the transmitter may be employed.

27.53 (h)

For operations in the 1710 – 1755 MHz and 1710 – 1780 MHz band, the FCC limit is $43 + 10\log_{10}(P[\text{Watts}])$ dB below the transmitter power $P(\text{Watts})$ in a 1 MHz bandwidth. However, in the 1MHz bands immediately outside and adjacent to the licensee's frequency block, a resolution bandwidth of at least one percent of the emission bandwidth of the fundamental emission of the transmitter may be employed.

27.53(m)(4)

For mobile digital stations, the attenuation factor shall be not less than $40 + 10 \log (P)$ dB on all frequencies between the channel edge and 5 megahertz from the channel edge, $43 + 10 \log (P)$ dB on all frequencies between 5 megahertz and X megahertz from the channel edge, and $55 + 10 \log (P)$ dB on all frequencies more than X megahertz from the channel edge, where X is the greater of 6 megahertz or the actual emission bandwidth as defined in paragraph (m)(6) of this section. In addition, the attenuation factor shall not be less that $43 + 10 \log (P)$ dB on all frequencies between 2490.5 MHz and 2496 MHz and $55 + 10 \log (P)$ dB at or below 2490.5 MHz. Mobile Satellite Service licensees operating on frequencies below 2495 MHz may also submit a documented interference complaint against BRS licensees operating on channel BRS Channel 1 on the same terms and conditions as adjacent channel BRS or EBS licensees.



3.7.2 Test Procedures

1. The testing follows FCC KDB 971168 v02r02 Section 6.0.
2. The EUT was connected to spectrum analyzer and system simulator via a power divider.
3. The band edges of low and high channels for the highest RF powers were measured.
4. Set RBW \geq 1% EBW in the 1MHz band immediately outside and adjacent to the band edge.
5. Beyond the 1 MHz band from the band edge, RBW=1MHz was used.
6. Set spectrum analyzer with RMS detector.
7. Offset has included the duty factor for LTE Band 41. Duty factor = $10 \log (1/x)$, where x is the measured duty cycle.
8. The RF fundamental frequency should be excluded against the limit line in the operating frequency band.
9. Checked that all the results comply with the emission limit line.

Example:

The limit line is derived from $43 + 10\log(P)$ dB below the transmitter power P(Watts)

$$= P(W) - [43 + 10\log(P)] \text{ (dB)}$$

$$= [30 + 10\log(P)] \text{ (dBm)} - [43 + 10\log(P)] \text{ (dB)} = -13\text{dBm}.$$

10. For LTE Band 41, the other 40 dB, and 55 dB have additionally applied same calculation above.



3.8 Conducted Spurious Emission

3.8.1 Description of Conducted Spurious Emission Measurement

The power of any emission outside of the authorized operating frequency ranges must be lower than the transmitter power (P) by a factor of at least $43 + 10 \log (P)$ dB.

For Band 41:

The power of any emission outside of the authorized operating frequency ranges must be lower than the transmitter power (P) by a factor of at least $55 + 10 \log (P)$ dB.

It is measured by means of a calibrated spectrum analyzer and scanned from 30 MHz up to a frequency including its 10th harmonic.

3.8.2 Test Procedures

1. The testing follows FCC KDB 971168 v02r02 Section 6.0.
2. The EUT was connected to spectrum analyzer and system simulator via a power divider.
3. The RF output of EUT was connected to the spectrum analyzer by RF cable and attenuator. The path loss was compensated to the results for each measurement.
4. The middle channel for the highest RF power within the transmitting frequency was measured.
5. The conducted spurious emission for the whole frequency range was taken.
6. Make the measurement with the spectrum analyzer's RBW = 1MHz, VBW = 3MHz.
7. Set spectrum analyzer with RMS detector.
8. Taking the record of maximum spurious emission.
9. Offset has included the duty factor for LTE Band 41. Duty factor = $10 \log (1/x)$, where x is the measured duty cycle.
10. The RF fundamental frequency should be excluded against the limit line in the operating frequency band.
11. The limit line is derived from $43 + 10 \log (P)$ dB below the transmitter power P(Watts)
= $P(W) - [43 + 10 \log (P)]$ (dB)
= $[30 + 10 \log (P)]$ (dBm) - $[43 + 10 \log (P)]$ (dB)
= -13dBm.
12. For Band 41
The limit line is derived from $55 + 10 \log (P)$ dB below the transmitter power P(Watts)
= $P(W) - [55 + 10 \log (P)]$ (dB)
= $[30 + 10 \log (P)]$ (dBm) - $[55 + 10 \log (P)]$ (dB)
= -25dBm.



3.9 Frequency Stability

3.9.1 Description of Frequency Stability Measurement

The frequency stability shall be measured by variation of ambient temperature and variation of primary supply voltage to ensure that the fundamental emission stays within the authorized frequency block. The frequency stability of the transmitter shall be maintained within $\pm 0.00025\%$ ($\pm 2.5\text{ppm}$) of the center frequency.

3.9.2 Test Procedures for Temperature Variation

1. The testing follows FCC KDB 971168 v02r02 Section 9.0.
2. The EUT was set up in the thermal chamber and connected with the system simulator.
3. With power OFF, the temperature was decreased to -30°C and the EUT was stabilized before testing. Power was applied and the maximum change in frequency was recorded within one minute.
4. With power OFF, the temperature was raised in 10°C step up to 50°C . The EUT was stabilized at each step for at least half an hour. Power was applied and the maximum frequency change was recorded within one minute.

3.9.3 Test Procedures for Voltage Variation

1. The testing follows FCC KDB 971168 v02r02 Section 9.0.
2. The EUT was placed in a temperature chamber at $20\pm 5^{\circ}\text{C}$ and connected with the system simulator.
3. The power supply voltage to the EUT was varied from 85% to 115% of the nominal value measured at the input to the EUT.
4. The variation in frequency was measured for the worst case.

4 Radiated Test Items

4.1 Measuring Instruments

See list of measuring instruments of this test report.

4.2 Test Setup

4.2.1 For radiated test from 30MHz to 1GHz

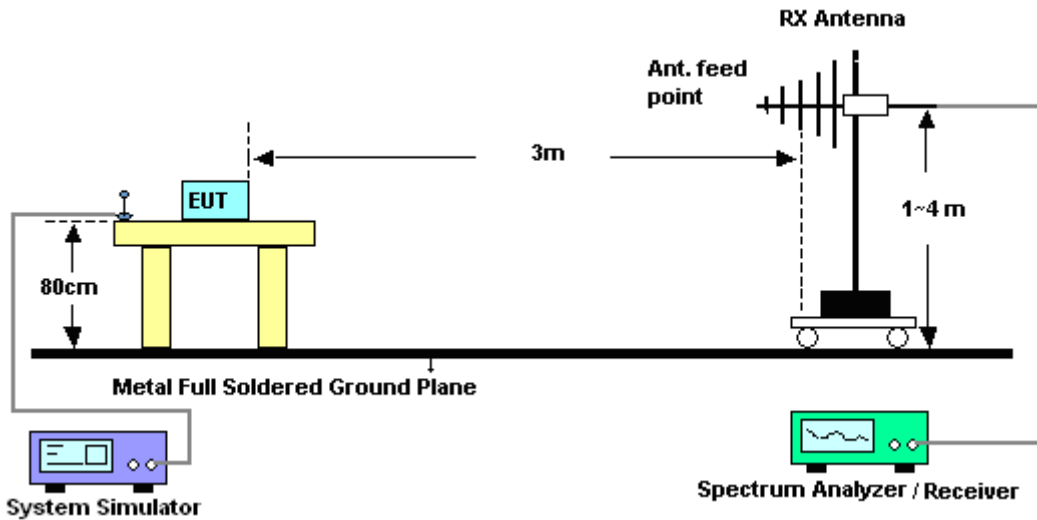

4.2.2 For radiated test above 1GHz

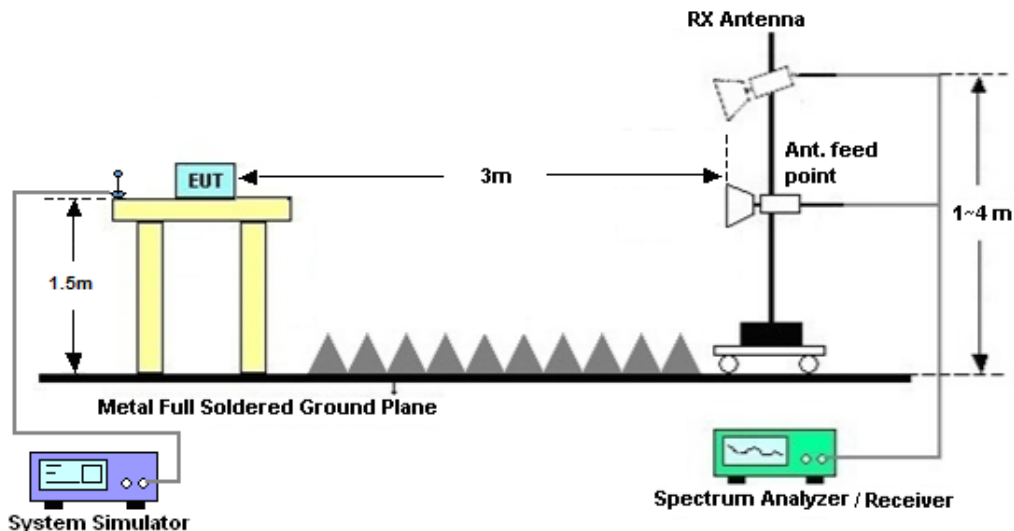

4.3 Test Result of Radiated Test

Please refer to Appendix B.



4.4 Radiated Spurious Emission

4.4.1 Description of Radiated Spurious Emission

The radiated spurious emission was measured by substitution method according to ANSI / TIA / EIA-603-D-2010. The power of any emission outside of the authorized operating frequency ranges must be attenuated below the transmitter power (P) by a factor of at least $43 + 10 \log (P)$ dB.

For Band 41

The power of any emission outside of the authorized operating frequency ranges must be attenuated below the transmitter power (P) by a factor of at least $55 + 10 \log (P)$ dB.

The spectrum is scanned from 30 MHz up to a frequency including its 10th harmonic.

4.4.2 Test Procedures

1. The testing follows FCC KDB 971168 v02r02 Section 5.8 and ANSI / TIA-603-D-2010 Section 2.2.12.
2. The EUT was placed on a turntable with 0.8 meter height for frequency below 1GHz and 1.5 meter height for frequency above 1GHz respectively above ground.
3. The EUT was set 3 meters from the receiving antenna mounted on the antenna tower.
4. The table was rotated 360 degrees to determine the position of the highest spurious emission.
5. The height of the receiving antenna is varied between 1m to 4m to search the maximum spurious emission for both horizontal and vertical polarizations.
6. During the measurement, the system simulator parameters were set to force the EUT transmitting at maximum output power.
7. Make the measurement with the spectrum analyzer's RBW = 1MHz, VBW = 3MHz, taking the record of maximum spurious emission.
8. A horn antenna was substituted in place of the EUT and was driven by a signal generator.
9. Tune the output power of signal generator to the same emission level with EUT maximum spurious emission.
10. $EIRP \text{ (dBm)} = S.G. \text{ Power} - Tx \text{ Cable Loss} + Tx \text{ Antenna Gain}$
11. $ERP \text{ (dBm)} = EIRP - 2.15$
12. The RF fundamental frequency should be excluded against the limit line in the operating frequency band.

The limit line is derived from $43 + 10\log(P)$ dB below the transmitter power P(Watts)
 $= P(W) - [43 + 10\log(P)] \text{ (dB)}$
 $= [30 + 10\log(P)] \text{ (dBm)} - [43 + 10\log(P)] \text{ (dB)}$
 $= -13\text{dBm}.$

13. For Band 41:

The limit line is derived from $55 + 10\log(P)$ dB below the transmitter power P(Watts)
 $EIRP \text{ (dBm)} = S.G. \text{ Power} - Tx \text{ Cable Loss} + Tx \text{ Antenna Gain}$
 $ERP \text{ (dBm)} = EIRP - 2.15$



5 List of Measuring Equipment

Instrument	Manufacturer	Model No.	Serial No.	Characteristics	Calibration Date	Test Date	Due Date	Remark
Spectrum Analyzer	R&S	FSV40	101040	10Hz~40GHz	Aug. 09, 2016	Jun. 28, 2017~ Jun. 29, 2017	Aug. 08, 2017	Conducted (TH01-KS)
Thermal Chamber	Ten Billion	TTC-B3S	TBN-960502	-40~+150°C	Oct. 13, 2016	Jun. 28, 2017~ Jun. 29, 2017	Oct. 12, 2017	Conducted (TH01-KS)
Radio communication	Anritsu	MT8820C	6201300652	2G/3G/LTE Band	Aug. 08, 2016	Jun. 28, 2017~ Jun. 29, 2017	Aug. 07, 2017	Conducted (TH01-KS)
EXA Spectrum Analyzer	Keysight	N9010A	MY55150244	10Hz-44GHz	Apr. 18, 2017	Aug. 03, 2017	Apr. 17, 2018	Radiation (03CH03-KS)
Bilog Antenna	TeseQ	CBL6112D	35406	25MHz-2GHz	Apr. 22, 2017	Aug. 03, 2017	Apr. 21, 2018	Radiation (03CH03-KS)
Horn Antenna	Schwarzbeck	BBHA9120D	9120D-1356	1GHz~18GHz	Apr. 22, 2017	Aug. 03, 2017	Apr. 21, 2018	Radiation (03CH03-KS)
SHF-EHF Horn	com-power	AH-840	101070	18GHz ~40GHz	Oct. 19, 2016	Aug. 03, 2017	Oct. 18, 2017	Radiation (03CH03-KS)
Amplifier	com-power	PA-103A	161069	1MHz ~1000MHz / 32 dB	Apr. 18, 2017	Aug. 03, 2017	Apr. 17, 2018	Radiation (03CH03-KS)
Amplifier	MITEQ	TTA1840-35 -HG	1887435	18~40GHz	Oct. 13, 2016	Aug. 03, 2017	Oct. 12, 2017	Radiation (03CH03-KS)
Amplifier	Agilent	8449B	3008A02370	1GHz~26.5GHz	Oct. 13, 2016	Aug. 03, 2017	Oct. 12, 2017	Radiation (03CH03-KS)
AC Power Source	Chroma	61601	F104090004	N/A	NCR	Aug. 03, 2017	NCR	Radiation (03CH03-KS)
Turn Table	ChamPro	EM 1000-T	060762-T	0~360 degree	NCR	Aug. 03, 2017	NCR	Radiation (03CH03-KS)
Antenna Mast	ChamPro	EM 1000-A	060762-A	1 m~4 m	NCR	Aug. 03, 2017	NCR	Radiation (03CH03-KS)

NCR: No Calibration Required



6 Uncertainty of Evaluation

Uncertainty of Radiated Emission Measurement (30 MHz ~ 1000 MHz)

Measuring Uncertainty for a Level of Confidence of 95% ($U = 2Uc(y)$)	2.8 dB
---	--------

Uncertainty of Radiated Emission Measurement (1GHz ~ 40GHz)

Measuring Uncertainty for a Level of Confidence of 95% ($U = 2Uc(y)$)	3.3 dB
---	--------



Appendix A. Test Results of Conducted Test

Conducted Output Power(Average power)

LTE Band 2 Maximum Average Power [dBm]						
BW [MHz]	RB Size	RB Offset	Mod	Lowest	Middle	Highest
20	1	0	QPSK	22.84	22.96	22.98
20	1	49		22.74	22.92	22.78
20	1	99		22.73	22.86	22.78
20	50	0		21.84	22.08	21.92
20	50	24		21.79	22.02	21.89
20	50	50		21.8	21.94	21.87
20	100	0		21.75	22.03	21.9
20	1	0	16-QAM	22.13	22.35	22.33
20	1	49		22.13	22.27	22.07
20	1	99		22.07	22.22	22.08
20	50	0		20.79	21.04	20.92
20	50	24		20.82	21.01	20.88
20	50	50		20.77	20.94	20.84
20	100	0		20.68	20.98	20.87
20	1	0	64QAM	22.05	22.09	22.18
20	1	49		21.88	22.09	21.93
20	1	99		21.91	22.08	21.93
20	50	0		20.73	21.04	20.89
20	50	24		20.82	20.94	20.86
20	50	50		20.77	20.94	20.8
20	100	0		20.69	20.97	20.88
15	1	0	QPSK	22.78	23.05	23.02
15	1	37		22.63	22.88	22.85
15	1	74		22.78	22.9	22.88
15	36	0		21.75	22.03	22.04
15	36	20		21.73	21.96	21.96
15	36	39		21.81	21.97	21.95
15	75	0		21.71	22.01	21.98



15	1	0	16-QAM	22.13	22.4	22.37
15	1	37		21.98	22.26	22.22
15	1	74		22.08	22.27	22.18
15	36	0		20.77	21.01	21
15	36	20		20.71	20.96	20.94
15	36	39		20.78	20.93	20.91
15	75	0		20.67	20.92	20.93
15	1	0	64QAM	22.01	22.25	22.19
15	1	37		21.85	22.09	22.06
15	1	74		21.89	22.09	22.07
15	36	0		20.73	20.99	20.99
15	36	20		20.71	20.95	20.93
15	36	39		20.77	20.94	20.9
15	75	0		20.67	20.94	20.93



LTE Band 2 Maximum Average Power [dBm]						
BW [MHz]	RB Size	RB Offset	Mod	Lowest	Middle	Highest
10	1	0	QPSK	22.7	22.96	22.93
10	1	25		22.67	22.89	22.86
10	1	49		22.72	22.9	22.88
10	25	0		21.71	21.98	21.94
10	25	12		21.72	21.97	21.93
10	25	25		21.67	21.91	21.88
10	50	0		21.7	21.98	21.95
10	1	0	16-QAM	21.98	22.24	22.25
10	1	25		21.95	22.2	22.19
10	1	49		21.99	22.2	22.18
10	25	0		20.7	20.94	20.89
10	25	12		20.68	20.97	20.92
10	25	25		20.66	20.92	20.88
10	50	0		20.7	20.95	20.92
10	1	0	64QAM	21.92	22.14	22.15
10	1	25		21.83	22.04	22.04
10	1	49		21.86	22.02	22.01
10	25	0		20.7	20.96	20.9
10	25	12		20.71	20.99	20.95
10	25	25		20.65	20.92	20.88
10	50	0		20.66	20.93	20.9
5	1	0	QPSK	22.66	22.96	22.94
5	1	12		22.63	22.89	22.87
5	1	24		22.64	22.89	22.85
5	12	0		21.68	21.94	21.89
5	12	7		21.71	21.97	21.91
5	12	13		21.63	21.91	21.89
5	25	0		21.66	21.93	21.89
5	1	0	16-QAM	21.97	22.28	22.21
5	1	12		21.97	22.22	22.15
5	1	24		21.96	22.21	22.19
5	12	0		20.68	20.93	20.89
5	12	7		20.71	20.99	20.9



5	12	13	64QAM	20.68	20.96	20.89
5	25	0		20.66	20.89	20.89
5	1	0		21.89	22.08	22.08
5	1	12		21.79	22.06	22.08
5	1	24		21.76	22.08	22.01
5	12	0		20.69	20.95	20.88
5	12	7		20.69	20.93	20.88
5	12	13		20.66	20.91	20.87
5	25	0		20.65	20.92	20.88



LTE Band 2 Maximum Average Power [dBm]						
BW [MHz]	RB Size	RB Offset	Mod	Lowest	Middle	Highest
3	1	0	QPSK	22.63	22.86	22.85
3	1	8		22.71	22.99	22.91
3	1	14		22.68	22.86	22.82
3	8	0		21.65	21.9	21.85
3	8	4		21.69	21.94	21.9
3	8	7		21.61	21.92	21.83
3	15	0		21.64	21.92	21.85
3	1	0	16-QAM	21.91	22.19	22.13
3	1	8		21.97	22.25	22.28
3	1	14		21.92	22.21	22.12
3	8	0		20.72	20.96	20.9
3	8	4		20.74	21.02	20.94
3	8	7		20.68	20.95	20.9
3	15	0		20.65	20.91	20.86
3	1	0	64QAM	21.8	22	22
3	1	8		21.9	22.13	22.13
3	1	14		21.74	21.96	22.03
3	8	0		20.65	20.92	20.87
3	8	4		20.69	20.91	20.89
3	8	7		20.63	20.9	20.86
3	15	0		20.65	20.89	20.85
1.4	1	0	QPSK	22.58	22.82	22.75
1.4	1	3		22.64	22.87	22.82
1.4	1	5		22.55	22.79	22.75
1.4	3	0		22.63	22.85	22.84
1.4	3	1		22.68	22.92	22.87
1.4	3	3		22.68	22.92	22.88
1.4	6	0		21.57	21.84	21.77
1.4	1	0	16-QAM	21.83	22.16	22.08
1.4	1	3		21.9	22.2	22.15
1.4	1	5		21.86	22.14	22.06
1.4	3	0		21.64	21.88	21.85
1.4	3	1		21.69	21.93	21.89



1.4	3	3	64QAM	21.67	21.95	21.86
1.4	6	0		20.67	20.93	20.86
1.4	1	0		21.76	21.99	21.98
1.4	1	3		21.77	22.09	22.05
1.4	1	5		21.7	21.91	21.97
1.4	3	0		21.69	21.86	21.87
1.4	3	1		21.7	21.9	21.87
1.4	3	3		21.7	21.89	21.89
1.4	6	0		20.59	20.83	20.79



LTE Band 4 Maximum Average Power [dBm]						
BW [MHz]	RB Size	RB Offset	Mod	Lowest	Middle	Highest
20	1	0	QPSK	23.04	23.1	23.12
20	1	49		22.78	22.86	22.94
20	1	99		22.84	22.78	22.86
20	50	0		21.98	22.03	22.06
20	50	24		21.93	21.95	22.04
20	50	50		21.94	21.91	21.99
20	100	0		21.91	21.99	22.08
20	1	0	16-QAM	22.34	22.4	22.4
20	1	49		22.12	22.17	22.3
20	1	99		22.17	22.09	22.17
20	50	0		21	21.08	21.06
20	50	24		20.89	20.98	21.08
20	50	50		20.94	20.92	20.99
20	100	0		20.93	20.97	21.06
20	1	0	64QAM	22.24	22.3	22.24
20	1	49		21.96	22.06	22.12
20	1	99		22	21.94	22.03
20	50	0		20.98	21.06	21.01
20	50	24		20.89	20.98	21.07
20	50	50		20.93	20.92	20.98
20	100	0		20.92	20.97	21.08
15	1	0	QPSK	22.98	23.05	23.05
15	1	37		22.78	22.87	22.93
15	1	74		22.88	22.84	22.92
15	36	0		21.93	22.02	22.07
15	36	20		21.87	21.98	22.06
15	36	39		21.98	21.9	21.96
15	75	0		21.91	21.98	22.03
15	1	0	16-QAM	22.28	22.39	22.35
15	1	37		22.1	22.21	22.25
15	1	74		22.18	22.18	22.2
15	36	0		20.96	21.04	21.08



15	36	20		20.92	20.99	21
15	36	39		20.95	20.89	20.99
15	75	0		20.88	20.98	21.04
15	1	0	64QAM	22.2	22.22	22.19
15	1	37		22.03	22.05	22.08
15	1	74		22.1	22.01	22.07
15	36	0		20.95	20.98	21.08
15	36	20		20.92	20.98	21.02
15	36	39		20.97	20.89	20.99
15	75	0		20.88	20.96	21.04



LTE Band 4 Maximum Average Power [dBm]						
BW [MHz]	RB Size	RB Offset	Mod	Lowest	Middle	Highest
10	1	0	QPSK	22.85	22.98	23.04
10	1	25		22.75	22.86	22.95
10	1	49		22.7	22.82	22.88
10	25	0		21.81	21.99	22.05
10	25	12		21.78	21.94	22.01
10	25	25		21.74	21.9	21.98
10	50	0		21.78	21.92	22.02
10	1	0	16-QAM	22.13	22.3	22.38
10	1	25		22.01	22.17	22.28
10	1	49		21.98	22.14	22.22
10	25	0		20.82	20.98	21.03
10	25	12		20.79	20.97	20.99
10	25	25		20.75	20.92	20.95
10	50	0		20.8	20.94	21.01
10	1	0	64QAM	21.99	22.13	22.22
10	1	25		21.92	22.01	22.13
10	1	49		21.83	22	22.07
10	25	0		20.81	20.97	21.04
10	25	12		20.8	20.98	20.99
10	25	25		20.74	20.93	20.95
10	50	0		20.77	20.94	21.01
5	1	0	QPSK	22.81	22.9	22.99
5	1	12		22.74	22.85	22.93
5	1	24		22.68	22.86	22.9
5	12	0		21.76	21.9	21.97
5	12	7		21.8	21.95	21.96
5	12	13		21.75	21.88	21.97
5	25	0		21.75	21.9	21.99
5	1	0	16-QAM	22.05	22.27	22.24
5	1	12		22.03	22.23	22.25
5	1	24		21.98	22.13	22.25
5	12	0		20.76	20.92	20.99
5	12	7		20.78	20.97	21



5	12	13	64QAM	20.75	20.93	20.94
5	25	0		20.78	20.93	20.95
5	1	0		21.97	22.09	22.14
5	1	12		21.9	22.02	22.07
5	1	24		21.9	22	22.05
5	12	0		20.77	20.92	21
5	12	7		20.76	20.97	20.97
5	12	13		20.75	20.91	20.93
5	25	0		20.77	20.93	20.93



LTE Band 4 Maximum Average Power [dBm]						
BW [MHz]	RB Size	RB Offset	Mod	Lowest	Middle	Highest
3	1	0	QPSK	22.73	22.89	22.94
3	1	8		22.84	22.97	23.01
3	1	14		22.71	22.85	22.88
3	8	0		21.76	21.92	21.93
3	8	4		21.75	21.93	21.98
3	8	7		21.77	21.88	21.95
3	15	0		21.75	21.93	21.95
3	1	0	16-QAM	22.01	22.19	22.19
3	1	8		22.07	22.28	22.31
3	1	14		21.96	22.12	22.19
3	8	0		20.83	20.99	21.01
3	8	4		20.83	21	21.01
3	8	7		20.8	20.94	20.97
3	15	0		20.8	20.91	20.95
3	1	0	64QAM	21.93	22.03	22.08
3	1	8		22	22.13	22.15
3	1	14		21.85	21.97	22
3	8	0		20.76	20.95	20.97
3	8	4		20.81	20.96	20.98
3	8	7		20.73	20.89	20.94
3	15	0		20.77	20.87	20.91
1.4	1	0	QPSK	22.63	22.79	22.85
1.4	1	3		22.73	22.84	22.91
1.4	1	5		22.62	22.78	22.81
1.4	3	0		22.71	22.82	22.87
1.4	3	1		22.76	22.88	22.92
1.4	3	3		22.77	22.91	22.94
1.4	6	0		21.66	21.84	21.88
1.4	1	0	16-QAM	21.94	22.11	22.18
1.4	1	3		22.01	22.17	22.22
1.4	1	5		21.93	22.09	22.17
1.4	3	0		21.72	21.85	21.92
1.4	3	1		21.77	21.9	21.95



1.4	3	3	64QAM	21.77	21.91	21.95
1.4	6	0		20.77	20.91	20.95
1.4	1	0		21.8	22.01	22
1.4	1	3		21.88	22.05	22.11
1.4	1	5		21.78	21.96	22
1.4	3	0		21.73	21.89	21.96
1.4	3	1		21.78	21.91	21.98
1.4	3	3		21.78	21.94	21.97
1.4	6	0		20.7	20.81	20.89



LTE Band 41 Maximum Average Power [dBm]						
BW [MHz]	RB Size	RB Offset	Mod	Lowest	Middle	Highest
20	1	0	QPSK	23.03	23.03	23.34
20	1	49		22.97	22.99	23.3
20	1	99		23.03	23.01	23.26
20	50	0		22.09	22.2	22.37
20	50	24		22.05	22.11	22.33
20	50	50		22.07	22.11	22.35
20	100	0		22.07	22.04	22.39
20	1	0	16-QAM	22.1	22.11	22.41
20	1	49		22.04	22.16	22.38
20	1	99		22.02	22.05	22.3
20	50	0		21.07	21.13	21.42
20	50	24		21.12	21.16	21.38
20	50	50		21.09	21.1	21.33
20	100	0		21.05	21.08	21.31
20	1	0	64QAM	22	21.92	22.16
20	1	49		21.95	21.9	22.06
20	1	99		21.92	21.86	22.07
20	50	0		21.04	21.11	21.32
20	50	24		21.04	21.13	21.34
20	50	50		21.03	21.07	21.28
20	100	0		21.13	21.13	21.44
15	1	0	QPSK	22.99	22.99	23.25
15	1	37		22.91	22.97	23.26
15	1	74		23.01	23.11	23.27
15	36	0		22.05	22.04	22.31
15	36	20		22.11	22.11	22.29
15	36	39		21.97	22.07	22.21
15	75	0		22.02	22.08	22.31
15	1	0	16-QAM	22.07	22.13	22.36
15	1	37		22.04	22.08	22.33
15	1	74		22.07	22.17	22.29
15	36	0		20.98	21.05	21.29



15	36	20		21.06	21.11	21.29
15	36	39		21.02	21.06	21.3
15	75	0		21.07	21.16	21.34
15	1	0	64QAM	22.01	21.97	22.1
15	1	37		21.94	21.83	22.03
15	1	74		22.01	21.82	22.05
15	36	0		21.04	21.09	21.38
15	36	20		21.08	21.1	21.27
15	36	39		21.06	21.11	21.33
15	75	0		21.08	21.12	21.34



LTE Band 41 Maximum Average Power [dBm]						
BW [MHz]	RB Size	RB Offset	Mod	Lowest	Middle	Highest
10	1	0	QPSK	22.97	23.02	23.26
10	1	25		22.97	23.01	23.29
10	1	49		23.02	23.03	23.32
10	25	0		22.01	22.08	22.34
10	25	12		22.04	22.11	22.35
10	25	25		22.03	22.12	22.33
10	50	0		22.03	22.12	22.36
10	1	0	16-QAM	22.08	22.15	22.41
10	1	25		22.05	22.08	22.29
10	1	49		22.03	22.15	22.32
10	25	0		21.05	21.13	21.3
10	25	12		21.04	21.12	21.39
10	25	25		21	21.09	21.39
10	50	0		21.06	21.12	21.33
10	1	0	64QAM	21.88	21.86	22.11
10	1	25		21.91	21.84	22.1
10	1	49		21.84	21.88	22.12
10	25	0		20.97	21.05	21.37
10	25	12		21.03	21.02	21.33
10	25	25		20.99	21.07	21.33
10	50	0		21.01	21.02	21.29
5	1	0	QPSK	22.96	23.01	23.24
5	1	12		22.95	23	23.2
5	1	24		22.92	22.99	23.25
5	12	0		21.97	22.06	22.26
5	12	7		22.03	22.06	22.31
5	12	13		22.02	22.12	22.32
5	25	0		21.95	22.11	22.27
5	1	0	16-QAM	22.01	22.09	22.33
5	1	12		22.02	22	22.3
5	1	24		22.01	22.06	22.4
5	12	0		20.96	21.03	21.24
5	12	7		21.02	21.08	21.3



5	12	13	64QAM	20.96	21.06	21.29
5	25	0		21.02	21.17	21.37
5	1	0		21.77	21.86	21.99
5	1	12		21.9	21.89	22.1
5	1	24		21.97	21.88	22.06
5	12	0		20.94	21.04	21.28
5	12	7		21	21.09	21.32
5	12	13		20.96	21.08	21.25
5	25	0		20.99	21.07	21.15



EIRP

LTE Band 2 (G _T - L _C = -1.60 dB) QPSK									
Bandwidth	1.4M			3M			5M		
Channel	18607	18900	19193	18615	18900	19185	18625	18900	19175
	(Low)	(Mid)	(High)	(Low)	(Mid)	(High)	(Low)	(Mid)	(High)
Frequency	1850.7	1880	1909.3	1851.5	1880	1908.5	1852.5	1880	1907.5
(MHz)									
Conducted Power (dBm)	22.68	22.92	22.88	22.71	22.99	22.91	22.66	22.96	22.94
Conducted Power (Watts)	0.1854	0.1959	0.1941	0.1866	0.1991	0.1954	0.1845	0.1977	0.1968
EIRP(dBm)	21.08	21.32	21.28	21.11	21.39	21.31	21.06	21.36	21.34
EIRP(Watts)	0.1282	0.1355	0.1343	0.1291	0.1377	0.1352	0.1276	0.1368	0.1361

LTE Band 2 (G _T - L _C = -1.60 dB) QPSK									
Bandwidth	10M			15M			20M		
Channel	18650	18900	19150	18675	18900	19125	18650	18900	19100
	(Low)	(Mid)	(High)	(Low)	(Mid)	(High)	(Low)	(Mid)	(High)
Frequency	1855	1880	1905	1857.5	1880	1902.5	1860	1880	1900
(MHz)									
Conducted Power (dBm)	22.70	22.96	22.93	22.78	23.05	23.02	22.84	22.96	22.98
Conducted Power (Watts)	0.1862	0.1977	0.1963	0.1897	0.2018	0.2004	0.1923	0.1977	0.1986
EIRP(dBm)	21.10	21.36	21.33	21.18	21.45	21.42	21.24	21.36	21.38
EIRP(Watts)	0.1288	0.1368	0.1358	0.1312	0.1396	0.1387	0.1330	0.1368	0.1374



LTE Band 2 ($G_T - L_C = -1.60$ dB) 16QAM									
Bandwidth	1.4M			3M			5M		
Channel	18607	18900	19193	18615	18900	19185	18625	18900	19175
	(Low)	(Mid)	(High)	(Low)	(Mid)	(High)	(Low)	(Mid)	(High)
Frequency (MHz)	1850.7	1880	1909.3	1851.5	1880	1908.5	1852.5	1880	1907.5
Conducted Power (dBm)	21.90	22.20	22.15	21.97	22.25	22.28	21.97	22.28	22.21
Conducted Power (Watts)	0.1549	0.1660	0.1641	0.1574	0.1679	0.1690	0.1574	0.1690	0.1663
EIRP(dBm)	20.30	20.60	20.55	20.37	20.65	20.68	20.37	20.68	20.61
EIRP(Watts)	0.1072	0.1148	0.1135	0.1089	0.1161	0.1169	0.1089	0.1169	0.1151

LTE Band 2 ($G_T - L_C = -1.60$ dB) 16QAM									
Bandwidth	10M			15M			20M		
Channel	18650	18900	19150	18675	18900	19125	18650	18900	19100
	(Low)	(Mid)	(High)	(Low)	(Mid)	(High)	(Low)	(Mid)	(High)
Frequency (MHz)	1855	1880	1905	1857.5	1880	1902.5	1860	1880	1900
Conducted Power (dBm)	21.98	22.24	22.25	22.13	22.40	22.37	22.13	22.35	22.33
Conducted Power (Watts)	0.1578	0.1675	0.1679	0.1633	0.1738	0.1726	0.1633	0.1718	0.1710
EIRP(dBm)	20.38	20.64	20.65	20.53	20.80	20.77	20.53	20.75	20.73
EIRP(Watts)	0.1091	0.1159	0.1161	0.1130	0.1202	0.1194	0.1130	0.1189	0.1183



LTE Band 2 ($G_T - L_C = -1.60$ dB) 64QAM									
Bandwidth	1.4M			3M			5M		
Channel	18607	18900	19193	18615	18900	19185	18625	18900	19175
	(Low)	(Mid)	(High)	(Low)	(Mid)	(High)	(Low)	(Mid)	(High)
Frequency	1850.7	1880	1909.3	1851.5	1880	1908.5	1852.5	1880	1907.5
(MHz)									
Conducted Power (dBm)	21.77	22.09	22.05	21.90	22.13	22.13	21.89	22.08	22.08
Conducted Power (Watts)	0.1503	0.1618	0.1603	0.1549	0.1633	0.1633	0.1545	0.1614	0.1614
EIRP(dBm)	20.17	20.49	20.45	20.30	20.53	20.53	20.29	20.48	20.48
EIRP(Watts)	0.1040	0.1119	0.1109	0.1072	0.1130	0.1130	0.1069	0.1117	0.1117

LTE Band 2 ($G_T - L_C = -1.60$ dB) 64QAM									
Bandwidth	10M			15M			20M		
Channel	18650	18900	19150	18675	18900	19125	18650	18900	19100
	(Low)	(Mid)	(High)	(Low)	(Mid)	(High)	(Low)	(Mid)	(High)
Frequency	1855	1880	1905	1857.5	1880	1902.5	1860	1880	1900
(MHz)									
Conducted Power (dBm)	21.92	22.14	22.15	22.01	22.25	22.19	22.05	22.09	22.18
Conducted Power (Watts)	0.1556	0.1637	0.1641	0.1589	0.1679	0.1656	0.1603	0.1618	0.1652
EIRP(dBm)	20.32	20.54	20.55	20.41	20.65	20.59	20.45	20.49	20.58
EIRP(Watts)	0.1076	0.1132	0.1135	0.1099	0.1161	0.1146	0.1109	0.1119	0.1143



LTE Band 4 (G _T - L _C = -0.90 dB) QPSK									
Bandwidth	1.4M			3M			5M		
Channel	19957	20175	20393	19965	20175	20385	19975	20175	20375
	(Low)	(Mid)	(High)	(Low)	(Mid)	(High)	(Low)	(Mid)	(High)
Frequency	1710.7	1732.5	1754.3	1711.5	1732.5	1753.5	1712.5	1732.5	1752.5
(MHz)									
Conducted Power (dBm)	22.77	22.91	22.94	22.84	22.97	23.01	22.81	22.90	22.99
Conducted Power (Watts)	0.1892	0.1954	0.1968	0.1923	0.1982	0.2000	0.1910	0.1950	0.1991
EIRP(dBm)	21.87	22.01	22.04	21.94	22.07	22.11	21.91	22.00	22.09
EIRP(Watts)	0.1538	0.1589	0.1600	0.1563	0.1611	0.1626	0.1552	0.1585	0.1618

LTE Band 4 (G _T - L _C = -0.90 dB) QPSK									
Bandwidth	10M			15M			20M		
Channel	20000	20175	20350	20025	20175	20325	20050	20175	20300
	(Low)	(Mid)	(High)	(Low)	(Mid)	(High)	(Low)	(Mid)	(High)
Frequency	1715	1732.5	1750	1717.5	1732.5	1747.5	1720	1732.5	1745
(MHz)									
Conducted Power (dBm)	22.85	22.98	23.04	22.98	23.05	23.05	23.04	23.10	23.12
Conducted Power (Watts)	0.1928	0.1986	0.2014	0.1986	0.2018	0.2018	0.2014	0.2042	0.2051
EIRP(dBm)	21.95	22.08	22.14	22.08	22.15	22.15	22.14	22.20	22.22
EIRP(Watts)	0.1567	0.1614	0.1637	0.1614	0.1641	0.1641	0.1637	0.1660	0.1667



LTE Band 4 (G _T - L _C = -0.90 dB) 16QAM									
Bandwidth	1.4M			3M			5M		
Channel	19957	20175	20393	19965	20175	20385	19975	20175	20375
	(Low)	(Mid)	(High)	(Low)	(Mid)	(High)	(Low)	(Mid)	(High)
Frequency (MHz)	1710.7	1732.5	1754.3	1711.5	1732.5	1753.5	1712.5	1732.5	1752.5
Conducted Power (dBm)	22.01	22.17	22.22	22.07	22.28	22.31	22.05	22.27	22.27
Conducted Power (Watts)	0.1589	0.1648	0.1667	0.1611	0.1690	0.1702	0.1603	0.1687	0.1687
EIRP(dBm)	21.11	21.27	21.32	21.17	21.38	21.41	21.15	21.37	21.34
EIRP(Watts)	0.1291	0.1340	0.1355	0.1309	0.1374	0.1384	0.1303	0.1371	0.1361

LTE Band 4 (G _T - L _C = -0.90 dB) 16QAM									
Bandwidth	10M			15M			20M		
Channel	20000	20175	20350	20025	20175	20325	20050	20175	20300
	(Low)	(Mid)	(High)	(Low)	(Mid)	(High)	(Low)	(Mid)	(High)
Frequency (MHz)	1715	1732.5	1750	1717.5	1732.5	1747.5	1720	1732.5	1745
Conducted Power (dBm)	22.13	22.30	22.38	22.28	22.39	22.35	22.34	22.40	22.40
Conducted Power (Watts)	0.1633	0.1698	0.1730	0.1690	0.1734	0.1718	0.1714	0.1738	0.1738
EIRP(dBm)	21.23	21.40	21.48	21.38	21.49	21.45	21.44	21.50	21.50
EIRP(Watts)	0.1327	0.1380	0.1406	0.1374	0.1409	0.1396	0.1393	0.1413	0.1413



LTE Band 4 (G _T - L _C = -0.90 dB) 64QAM									
Bandwidth	1.4M			3M			5M		
Channel	19957	20175	20393	19965	20175	20385	19975	20175	20375
	(Low)	(Mid)	(High)	(Low)	(Mid)	(High)	(Low)	(Mid)	(High)
Frequency	1710.7	1732.5	1754.3	1711.5	1732.5	1753.5	1712.5	1732.5	1752.5
(MHz)									
Conducted Power (dBm)	21.88	22.05	22.11	22.00	22.13	22.15	21.97	22.09	22.14
Conducted Power (Watts)	0.1542	0.1603	0.1626	0.1585	0.1633	0.1641	0.1574	0.1618	0.1637
EIRP(dBm)	20.98	21.15	21.21	21.10	21.23	21.25	21.07	21.19	21.24
EIRP(Watts)	0.1253	0.1303	0.1321	0.1288	0.1327	0.1334	0.1279	0.1315	0.1330

LTE Band 4 (G _T - L _C = -0.90 dB) 64QAM									
Bandwidth	10M			15M			20M		
Channel	20000	20175	20350	20025	20175	20325	20050	20175	20300
	(Low)	(Mid)	(High)	(Low)	(Mid)	(High)	(Low)	(Mid)	(High)
Frequency	1715	1732.5	1750	1717.5	1732.5	1747.5	1720	1732.5	1745
(MHz)									
Conducted Power (dBm)	21.99	22.13	22.22	22.20	22.22	22.19	22.24	22.30	22.24
Conducted Power (Watts)	0.1581	0.1633	0.1667	0.1660	0.1667	0.1656	0.1675	0.1698	0.1675
EIRP(dBm)	21.09	21.23	21.32	21.30	21.32	21.29	21.34	21.40	21.34
EIRP(Watts)	0.1285	0.1327	0.1355	0.1349	0.1355	0.1346	0.1361	0.1380	0.1361



LTE Band 41 (G _T - L _C =2.80 dB) QPSK									
Bandwidth	5M			10M			15M		
Channel	39675	40620	41565	39700	40620	41540	39725	40620	41515
	(Low)	(Mid)	(High)	(Low)	(Mid)	(High)	(Low)	(Mid)	(High)
Frequency (MHz)	2498.5	2593	2687.5	2501	2593	2685	2503.5	2593	2682.5
Conducted Power (dBm)	22.92	22.99	23.25	23.02	23.03	23.32	23.01	23.11	23.27
Conducted Power (Watts)	0.1959	0.1991	0.2113	0.2004	0.2009	0.2148	0.2000	0.2046	0.2123
EIRP(dBm)	25.72	25.79	26.05	25.82	25.83	26.12	25.81	25.91	26.07
EIRP(Watts)	0.3733	0.3793	0.4027	0.3819	0.3828	0.4093	0.3811	0.3899	0.4046

LTE Band 41 (G _T - L _C =2.80 dB) QPSK			
Bandwidth	20M		
Channel	39750	40620	41490
	(Low)	(Mid)	(High)
Frequency (MHz)	2506	2593	2680
Conducted Power (dBm)	23.03	23.03	23.34
Conducted Power (Watts)	0.2009	0.2009	0.2158
EIRP(dBm)	25.83	25.83	26.14
EIRP(Watts)	0.3828	0.3828	0.4111



LTE Band 41 (G _T - L _C = 2.80 dB) 16QAM									
Bandwidth	5M			10M			15M		
Channel	39675	40620	41565	39700	40620	41540	39725	40620	41515
	(Low)	(Mid)	(High)	(Low)	(Mid)	(High)	(Low)	(Mid)	(High)
Frequency (MHz)	2498.5	2593	2687.5	2501	2593	2685	2503.5	2593	2682.5
Conducted Power (dBm)	22.01	22.06	22.40	22.08	22.15	22.41	22.07	22.13	22.36
Conducted Power (Watts)	0.1589	0.1607	0.1738	0.1614	0.1641	0.1742	0.1611	0.1633	0.1722
EIRP(dBm)	24.81	24.86	25.20	24.88	24.95	25.21	24.87	24.93	25.16
EIRP(Watts)	0.3027	0.3062	0.3311	0.3076	0.3126	0.3319	0.3069	0.3112	0.3281

LTE Band 41 (G _T - L _C = 2.80 dB) 16QAM			
Bandwidth	20M		
Channel	39750	40620	41490
	(Low)	(Mid)	(High)
Frequency (MHz)	2506	2593	2680
Conducted Power (dBm)	22.10	22.11	22.41
Conducted Power (Watts)	0.1622	0.1626	0.1742
EIRP(dBm)	24.90	24.91	25.21
EIRP(Watts)	0.3090	0.3097	0.3319



LTE Band 41 (G _T - L _C =2.80 dB) 64QAM									
Bandwidth	5M			10M			15M		
Channel	39675	40620	41565	39700	40620	41540	39725	40620	41515
	(Low)	(Mid)	(High)	(Low)	(Mid)	(High)	(Low)	(Mid)	(High)
Frequency	2498.5	2593	2687.5	2501	2593	2685	2503.5	2593	2682.5
(MHz)									
Conducted Power (dBm)	21.90	21.89	22.10	21.84	21.88	22.12	22.01	21.97	22.10
Conducted Power (Watts)	0.1549	0.1545	0.1622	0.1528	0.1542	0.1629	0.1589	0.1574	0.1622
EIRP(dBm)	24.70	24.69	24.90	24.64	24.68	24.92	24.81	24.77	24.90
EIRP(Watts)	0.2951	0.2944	0.3090	0.2911	0.2938	0.3105	0.3027	0.2999	0.3090

LTE Band 41 (G _T - L _C =2.80 dB) 64QAM			
Bandwidth	20M		
Channel	39750	40620	41490
	(Low)	(Mid)	(High)
Frequency	2506	2593	2680
(MHz)			
Conducted Power (dBm)	22.00	21.92	22.16
Conducted Power (Watts)	0.1585	0.1556	0.1644
EIRP(dBm)	24.80	24.72	24.96
EIRP(Watts)	0.3020	0.2965	0.3133



Peak-to-Average Ratio

Mode	LTE Band 2 / 20MHz				
Mod.	QPSK		16QAM		Limit: 13dB
RB Size	1RB	Full RB	1RB	Full RB	Result
Lowest CH	4.99	5.07	5.59	5.86	PASS
Middle CH	5.19	5.10	5.83	6.00	
Highest CH	5.16	5.01	5.77	5.91	
Mode	LTE Band 2 / 20MHz				
Mod.	64QAM				Limit: 13dB
RB Size	1RB	Full RB			Result
Lowest CH	5.36	5.91			PASS
Middle CH	5.65	6.03			
Highest CH	5.74	5.94			

Mode	LTE Band 4 / 20MHz				
Mod.	QPSK		16QAM		Limit: 13dB
RB Size	1RB	Full RB	1RB	Full RB	Result
Lowest CH	5.42	5.59	6.26	6.52	PASS
Middle CH	5.36	5.22	6.14	6.29	
Highest CH	4.81	5.25	5.83	6.23	
Mod.	64QAM		Limit: 13dB		
RB Size	1RB	Full RB	Result		
Lowest CH	6.03	6.46	PASS		
Middle CH	6.09	6.20			
Highest CH	5.51	6.26			

Mode	LTE Band 41 / 20MHz				
Mod.	QPSK		16QAM		Limit: 13dB
RB Size	1RB	Full RB	1RB	Full RB	Result
Lowest CH	4.52	6.20	5.88	6.17	PASS
Middle CH	4.99	5.30	5.88	6.12	
Highest CH	6.26	5.88	5.59	6.26	
Mod.	64QAM		Limit: 13dB		
RB Size	1RB	Full RB	Result		
Lowest CH	5.74	6.12	PASS		
Middle CH	6.14	6.14			
Highest CH	6.35	6.41			



LTE Band 2 / 20MHz / QPSK

Lowest Channel / 1RB

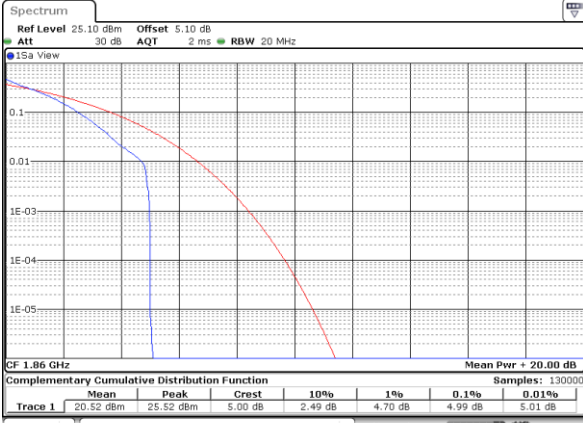

Date: 28 JUN 2017 20:27:42

Lowest Channel / Full RB

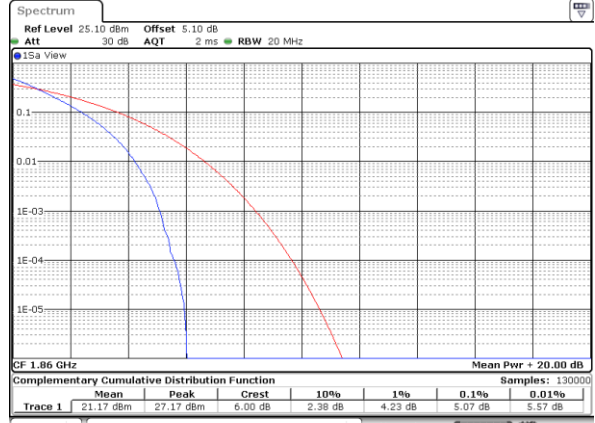

Date: 28 JUN 2017 20:28:59

Middle Channel / 1RB

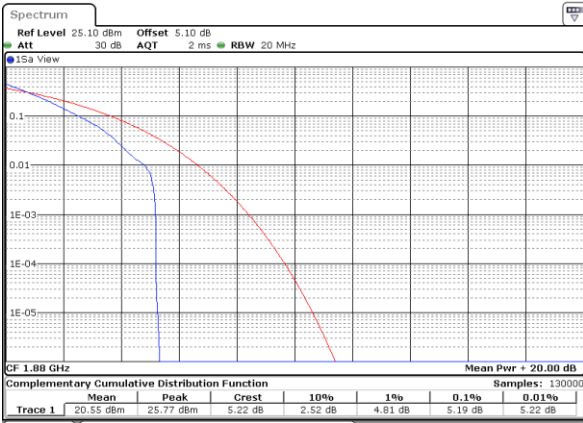

Date: 28 JUN 2017 20:29:24

Middle Channel / Full RB

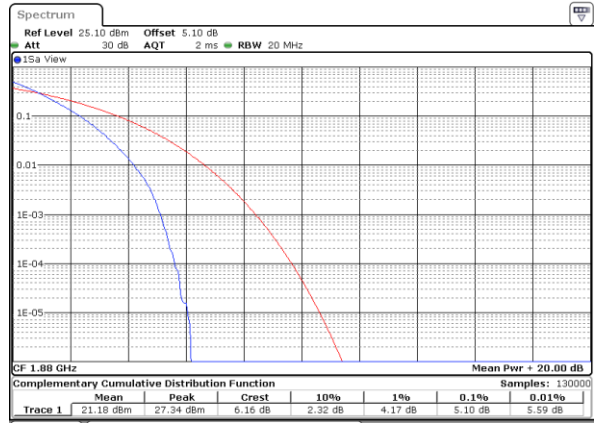

Date: 28 JUN 2017 20:30:31

Highest Channel / 1RB

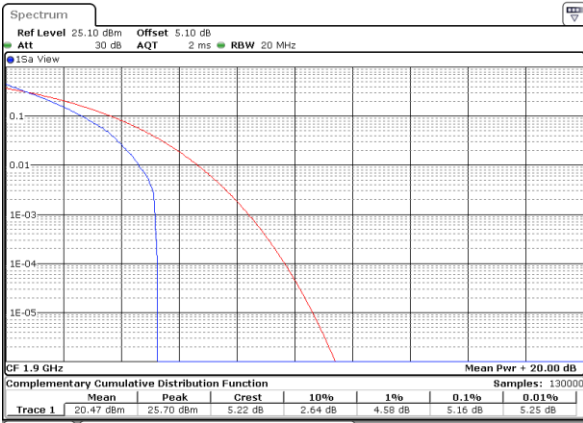

Date: 28 JUN 2017 20:30:48

Highest Channel / Full RB

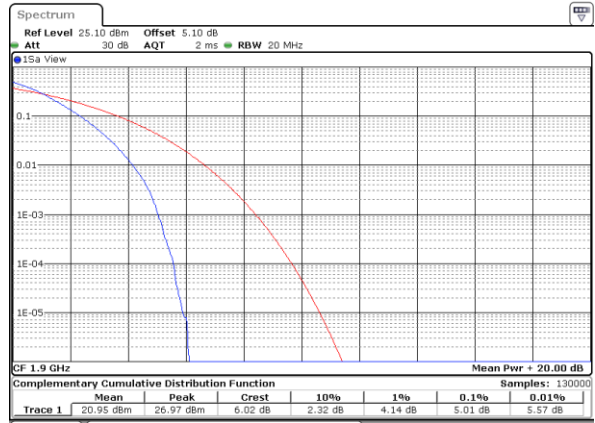

Date: 28 JUN 2017 20:32:03



LTE Band 2 / 20MHz / 16QAM

Lowest Channel / 1RB

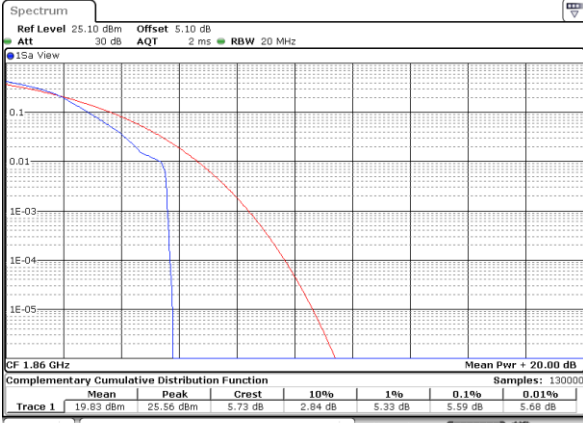

Date: 28 JUN 2017 20:27:56

Lowest Channel / Full RB

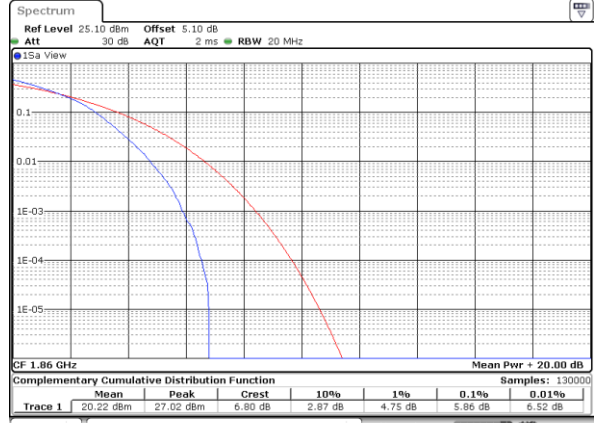

Date: 28 JUN 2017 20:28:37

Middle Channel / 1RB

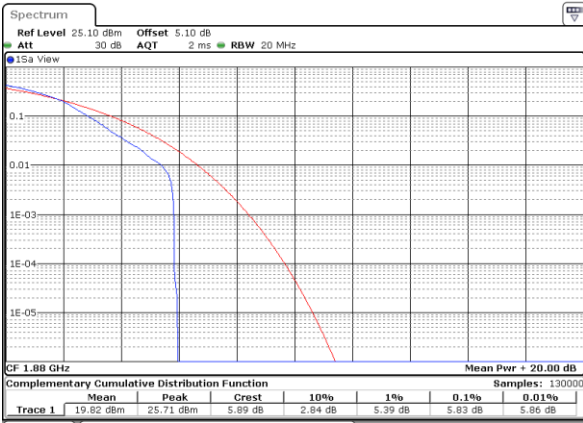

Date: 28 JUN 2017 20:29:38

Middle Channel / Full RB

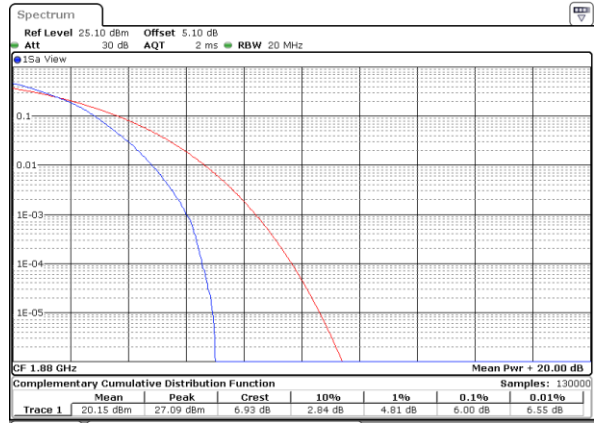

Date: 28 JUN 2017 20:30:18

Highest Channel / 1RB

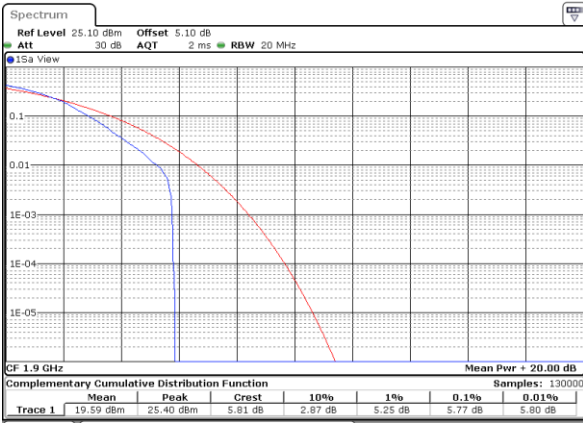

Date: 28 JUN 2017 20:31:00

Highest Channel / Full RB

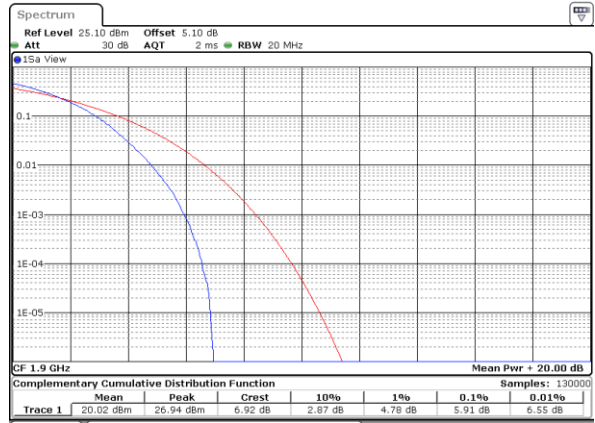

Date: 28 JUN 2017 20:31:41



LTE Band 2 / 20MHz / 64QAM

Lowest Channel / 1RB

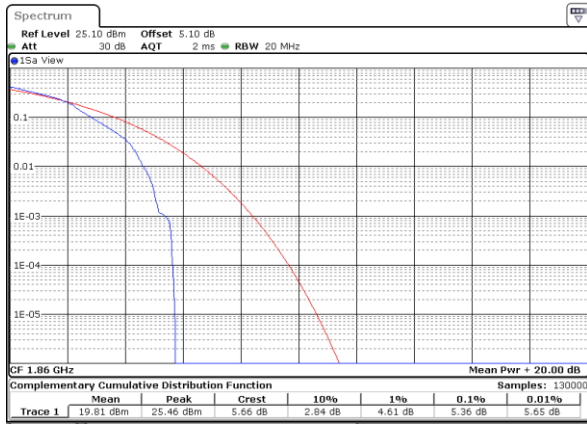

Date: 28 JUN 2017 20:28:08

Lowest Channel / Full RB

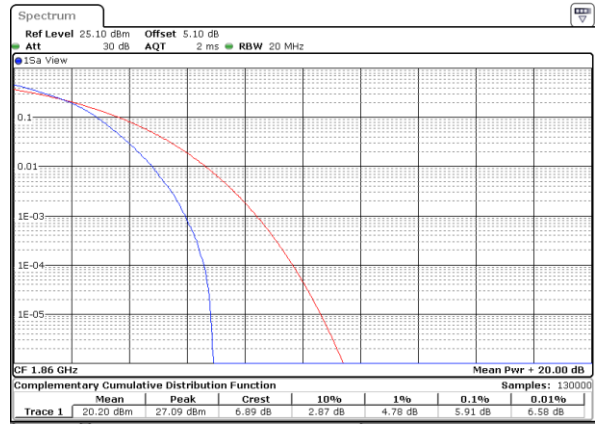

Date: 28 JUN 2017 20:28:23

Middle Channel / 1RB

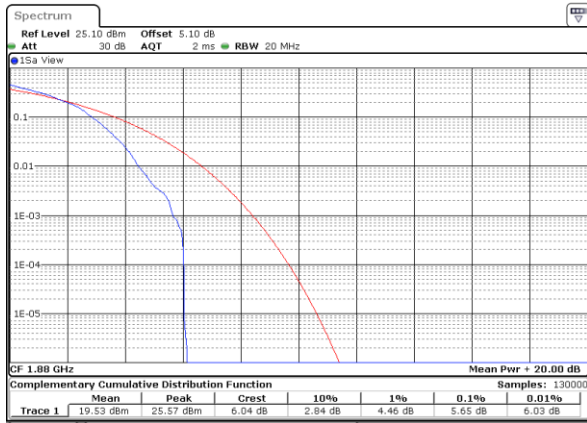

Date: 28 JUN 2017 20:29:50

Middle Channel / Full RB

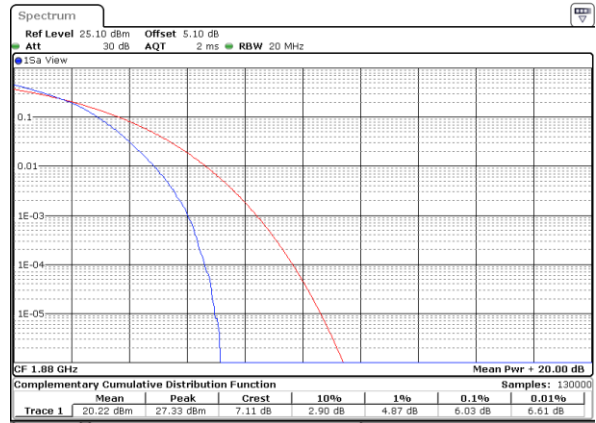

Date: 28 JUN 2017 20:30:03

Highest Channel / 1RB

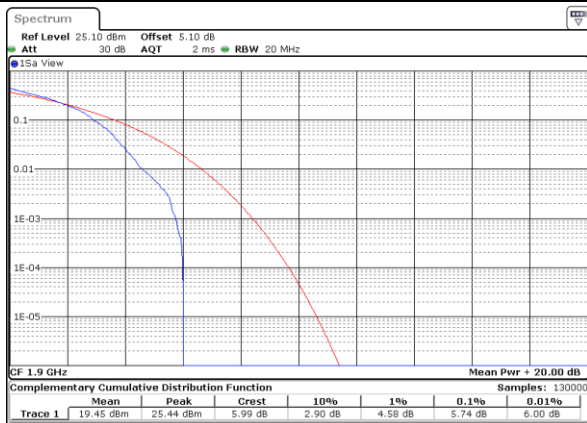

Date: 28 JUN 2017 20:31:12

Highest Channel / Full RB



Date: 28 JUN 2017 20:31:29



LTE Band 4 / 20MHz / QPSK

Lowest Channel / 1RB

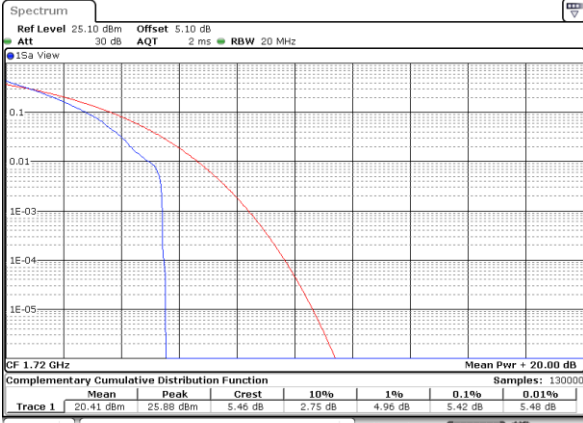

Date: 28 JUN 2017 14:45:14

Lowest Channel / Full RB

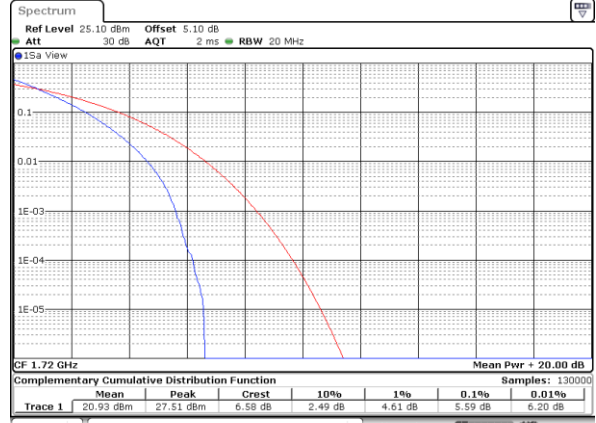

Date: 28 JUN 2017 14:45:59

Middle Channel / 1RB

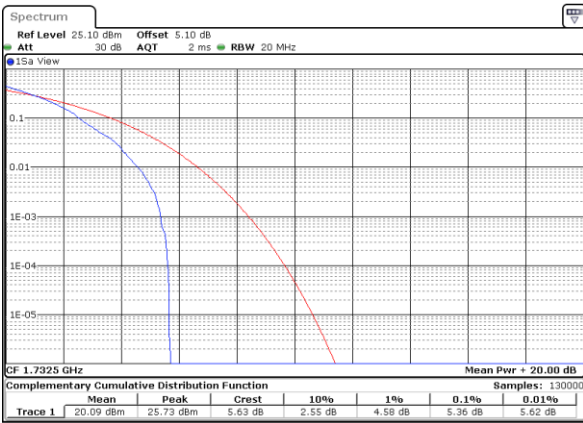

Date: 28 JUN 2017 14:46:55

Middle Channel / Full RB

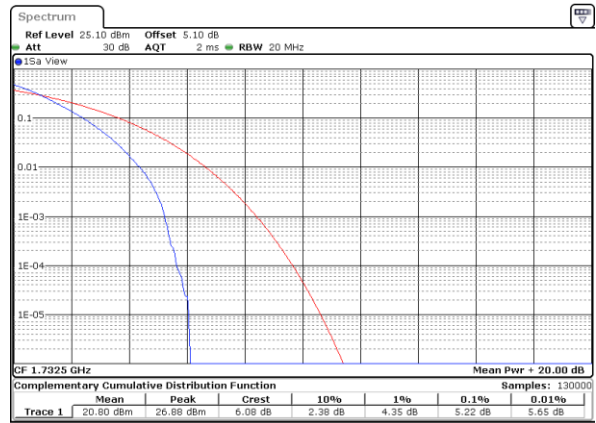

Date: 28 JUN 2017 14:46:07

Highest Channel / 1RB

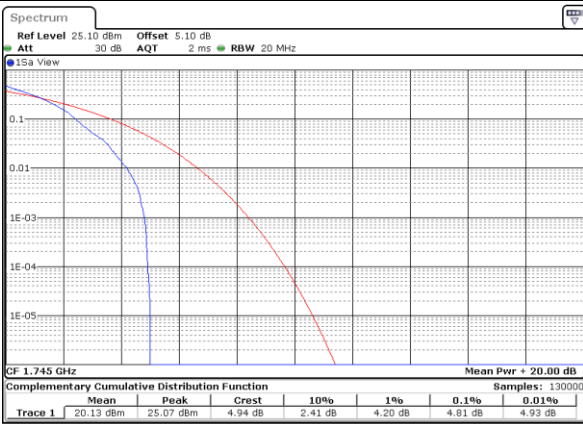

Date: 28 JUN 2017 14:47:08

Highest Channel / Full RB



Date: 28 JUN 2017 14:52:00



LTE Band 4 / 20MHz / 16QAM

Lowest Channel / 1RB

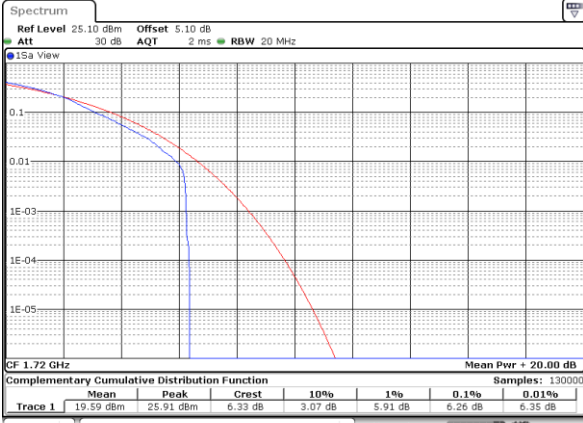

Date: 28 JUN 2017 14:45:22

Lowest Channel / Full RB

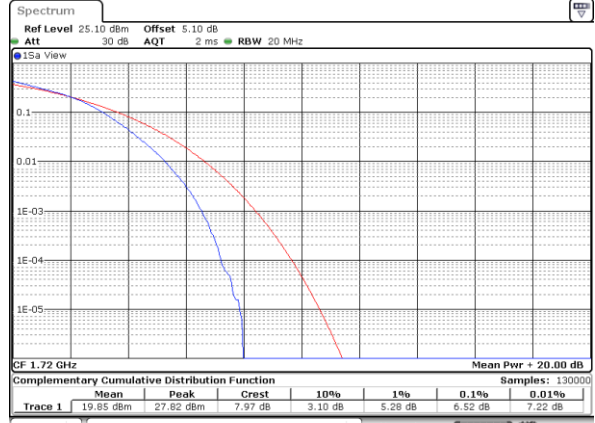

Date: 28 JUN 2017 14:48:58

Middle Channel / 1RB

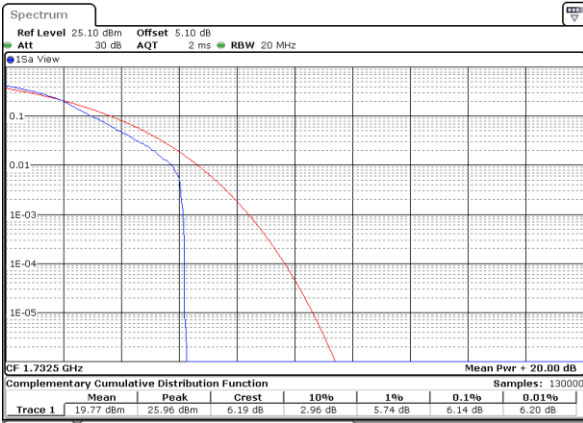

Date: 28 JUN 2017 14:46:43

Middle Channel / Full RB

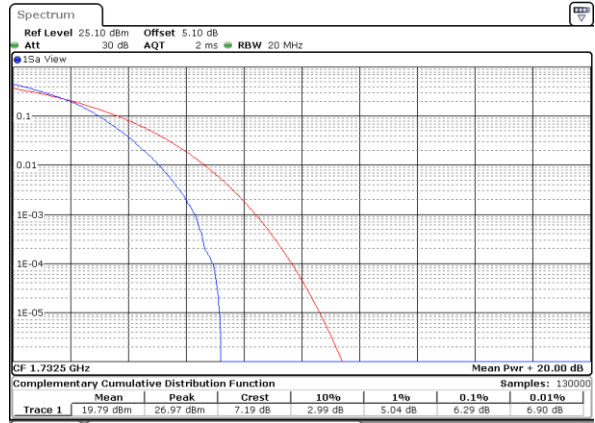

Date: 28 JUN 2017 14:46:16

Highest Channel / 1RB

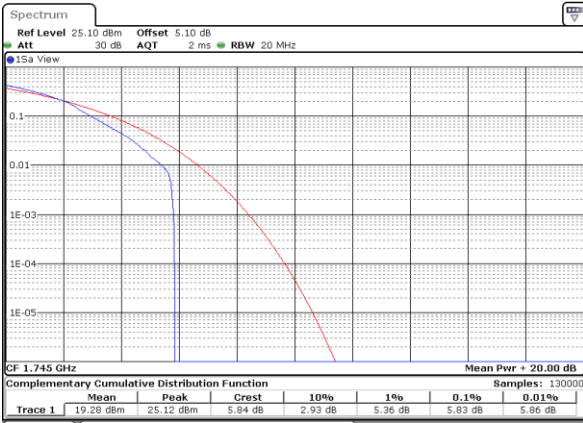

Date: 28 JUN 2017 14:50:10

Highest Channel / Full RB

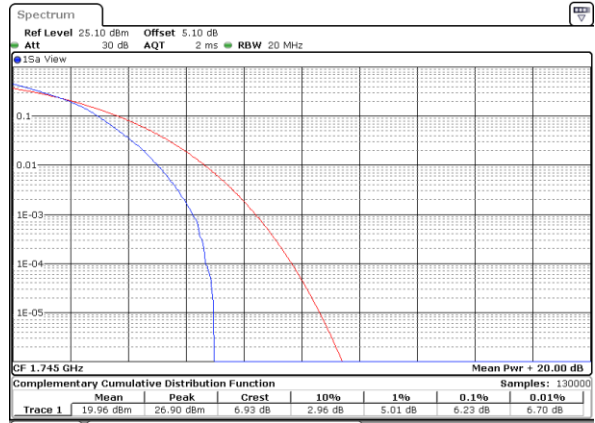

Date: 28 JUN 2017 14:51:16



LTE Band 4 / 20MHz / 64QAM

Lowest Channel / 1RB

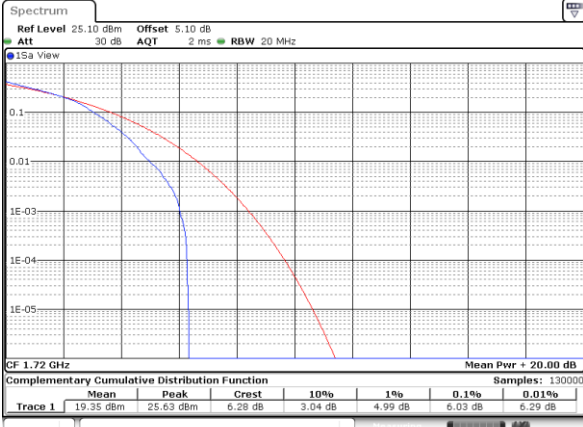

Date: 28 JUN 2017 14:45:31

Lowest Channel / Full RB

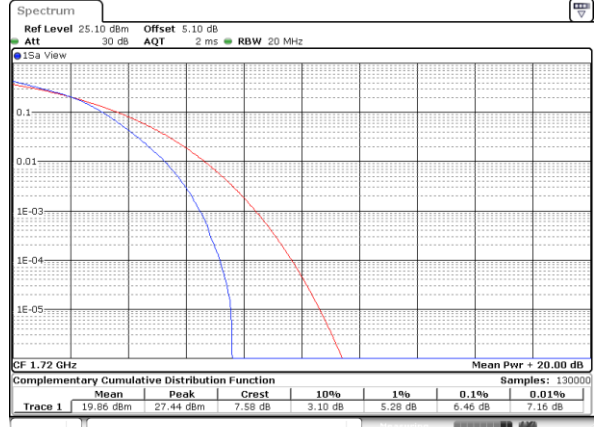

Date: 28 JUN 2017 14:49:22

Middle Channel / 1RB

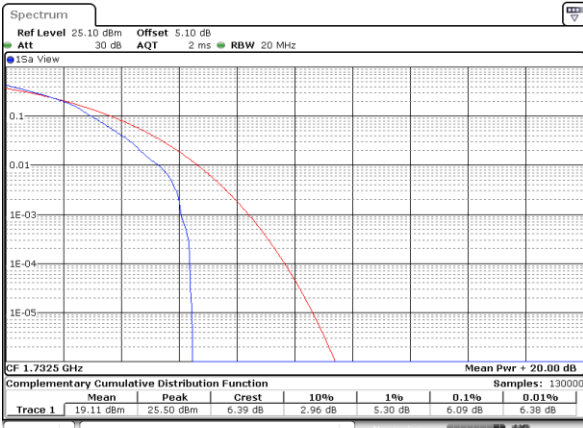

Date: 28 JUN 2017 14:46:34

Middle Channel / Full RB

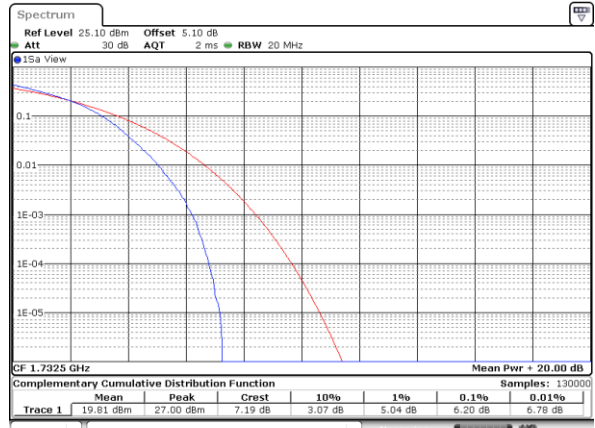

Date: 28 JUN 2017 14:46:25

Highest Channel / 1RB

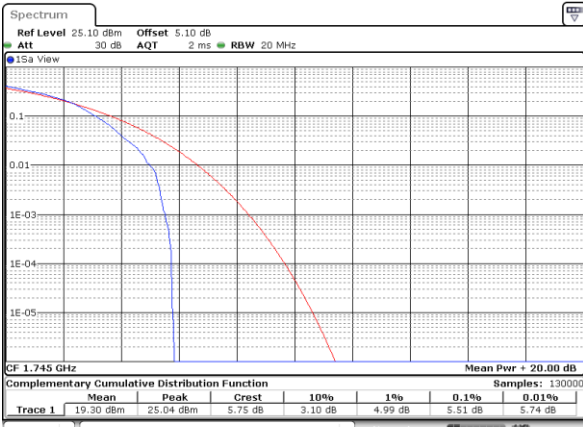

Date: 28 JUN 2017 14:50:42

Highest Channel / Full RB

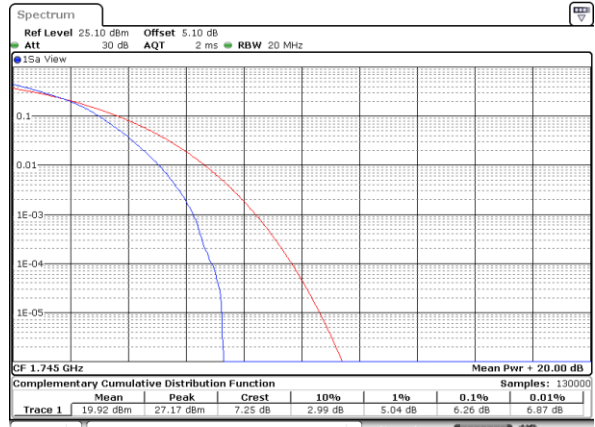

Date: 28 JUN 2017 14:47:47



LTE Band 41 / 20MHz / QPSK

Lowest Channel / 1RB

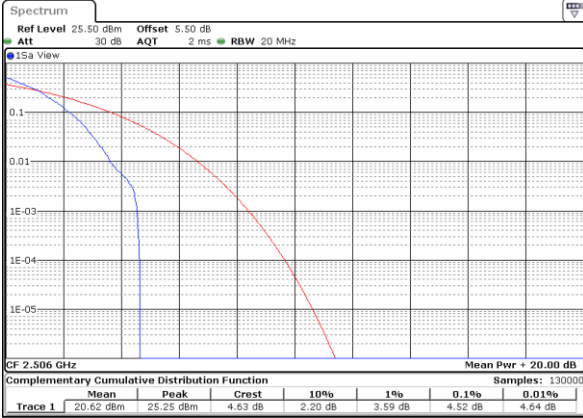

Date: 28 JUN 2017 21:53:51

Lowest Channel / Full RB

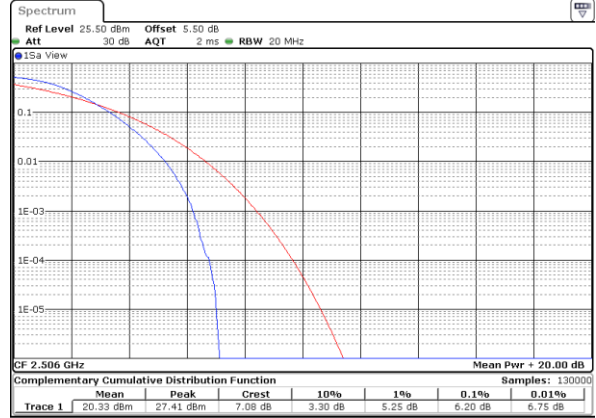

Date: 28 JUN 2017 21:54:58

Middle Channel / 1RB

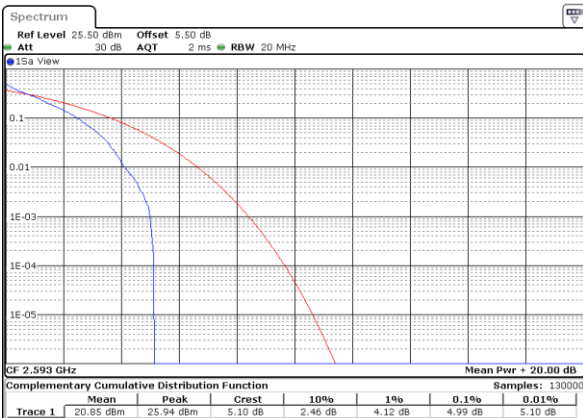

Date: 28 JUN 2017 21:57:49

Middle Channel / Full RB

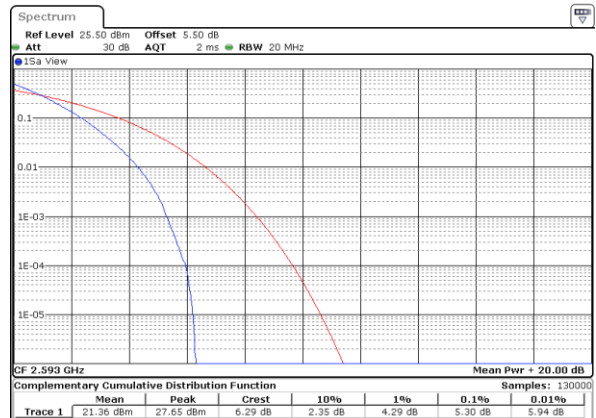

Date: 28 JUN 2017 21:56:08

Highest Channel / 1RB

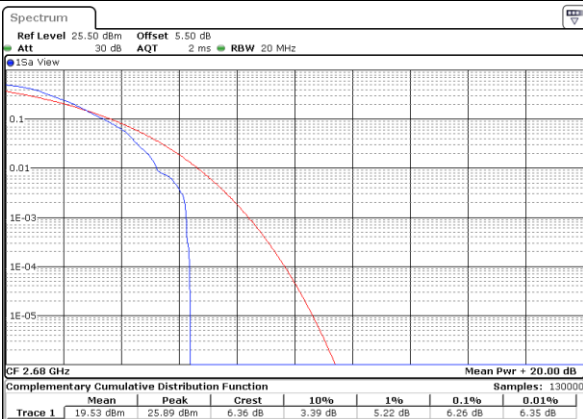

Date: 28 JUN 2017 21:58:16

Highest Channel / Full RB

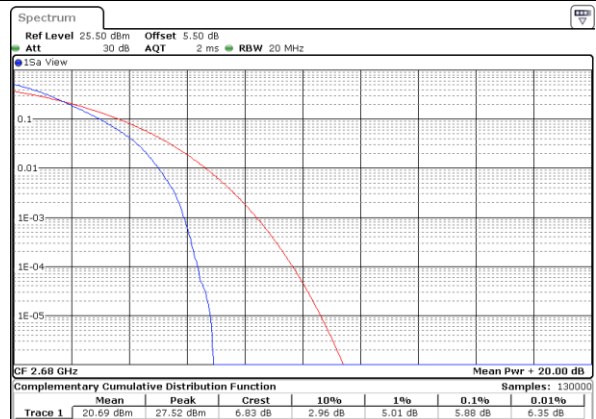

Date: 28 JUN 2017 21:59:20



LTE Band 41 / 20MHz / 16QAM

Lowest Channel / 1RB

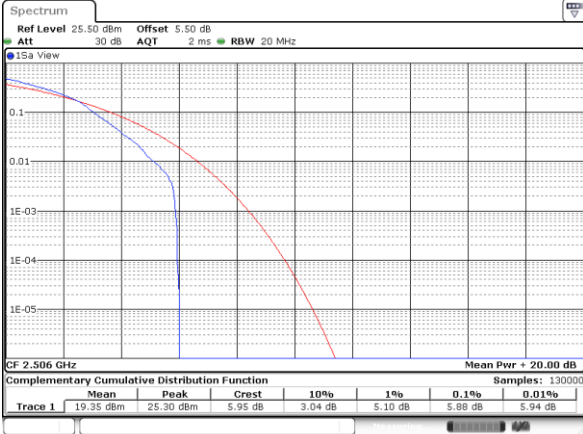

Date: 28 JUN 2017 21:54:05

Lowest Channel / Full RB

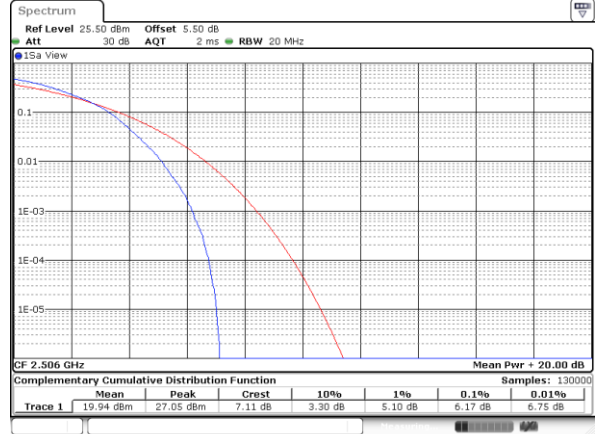

Date: 28 JUN 2017 21:55:17

Middle Channel / 1RB

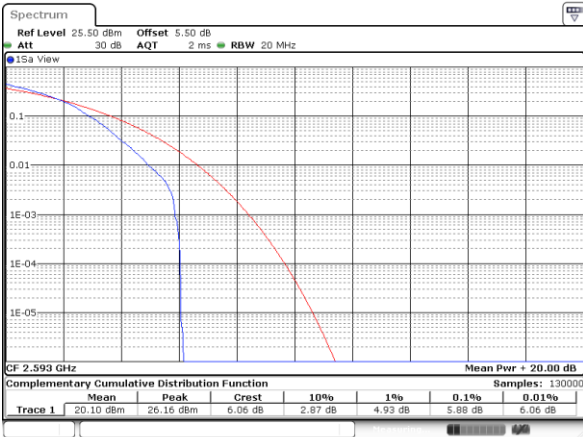

Date: 28 JUN 2017 21:57:31

Middle Channel / Full RB

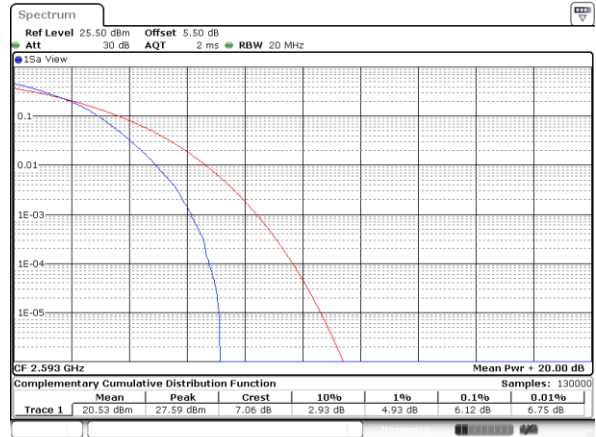

Date: 28 JUN 2017 21:56:32

Highest Channel / 1RB

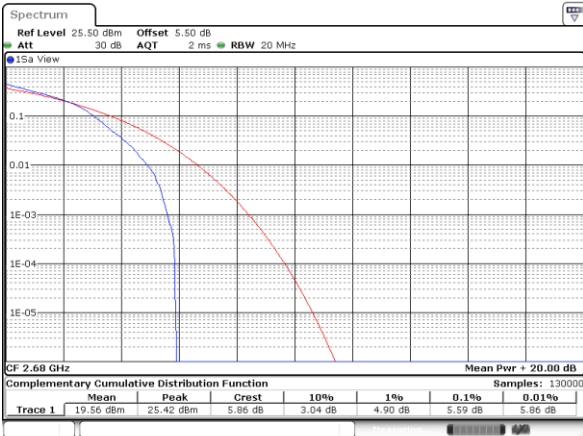

Date: 28 JUN 2017 21:58:33

Highest Channel / Full RB

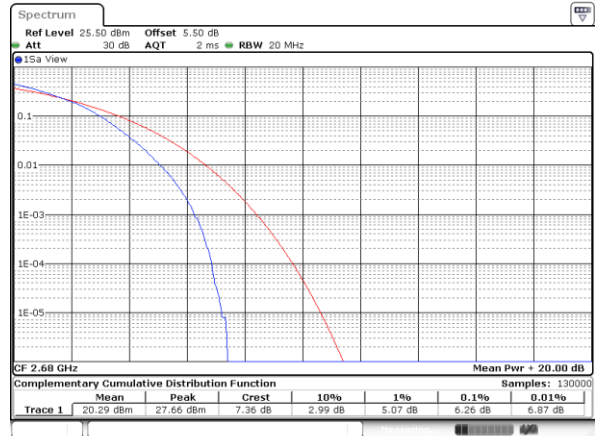

Date: 28 JUN 2017 22:00:09



LTE Band 41 / 20MHz / 64QAM

Lowest Channel / 1RB

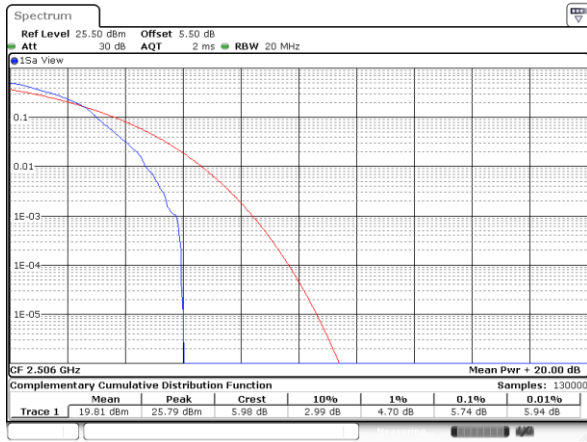

Date: 28 JUN 2017 21:54:31

Lowest Channel / Full RB

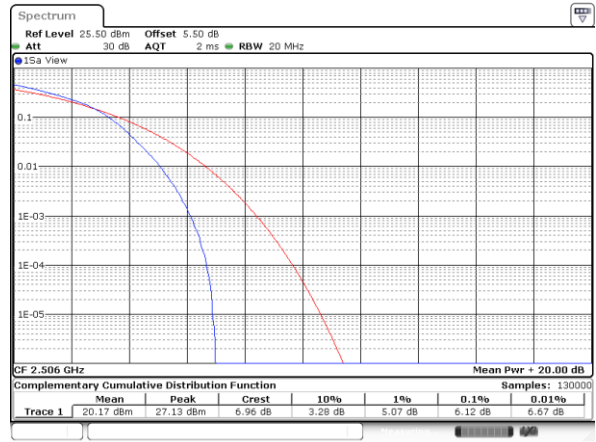

Date: 28 JUN 2017 21:55:38

Middle Channel / 1RB



Date: 28 JUN 2017 21:57:06

Middle Channel / Full RB



Date: 28 JUN 2017 21:56:49

Highest Channel / 1RB



Date: 28 JUN 2017 21:58:46

Highest Channel / Full RB

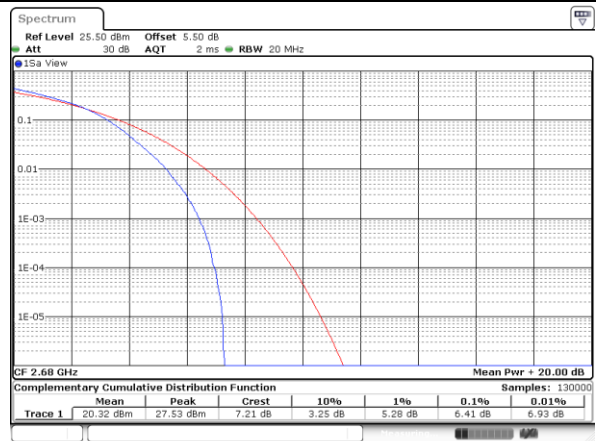

Date: 28 JUN 2017 22:00:36



26dB Bandwidth

Mode	LTE Band 2 : 26dB BW(MHz)											
BW	1.4MHz		3MHz		5MHz		10MHz		15MHz		20MHz	
Mod.	QPSK	16QAM	QPSK	16QAM	QPSK	16QAM	QPSK	16QAM	QPSK	16QAM	QPSK	16QAM
Lowest CH	1.228	1.236	3.039	3.003	4.935	4.865	9.99	9.79	14.535	14.386	20.18	20.26
Middle CH	1.225	1.225	2.997	2.991	4.975	4.875	9.67	9.75	14.446	14.296	20.10	20.10
Highest CH	1.225	1.234	3.039	2.985	4.925	4.935	9.89	9.83	14.296	14.416	20.30	20.18
BW	1.4MHz	3MHz	5MHz	10MHz	15MHz	20MHz						
Mod.	64QAM	64QAM	64QAM	64QAM	64QAM	64QAM						
Lowest CH	1.228	2.997	4.875	9.73	14.505	20.14						
Middle CH	1.222	3.093	4.935	9.79	14.386	20.26						
Highest CH	1.234	3.003	4.905	9.71	14.296	20.22						

Mode	LTE Band 4 : 26dB BW(MHz)											
BW	1.4MHz		3MHz		5MHz		10MHz		15MHz		20MHz	
Mod.	QPSK	16QAM	QPSK	16QAM	QPSK	16QAM	QPSK	16QAM	QPSK	16QAM	QPSK	16QAM
Lowest CH	1.236	1.228	3.039	3.003	4.905	4.965	9.77	9.83	14.655	14.236	20.26	20.22
Middle CH	1.214	1.231	3.039	3.021	4.925	4.885	9.69	9.77	14.296	14.386	20.18	20.10
Highest CH	1.228	1.228	3.003	3.021	4.955	4.905	9.75	9.71	14.416	14.266	20.06	20.18
BW	1.4MHz	3MHz	5MHz	10MHz	15MHz	20MHz						
Mod.	64QAM	64QAM	64QAM	64QAM	64QAM	64QAM						
Lowest CH	1.220	3.003	4.885	9.77	14.176	20.14						
Middle CH	1.234	3.033	4.825	9.85	14.446	20.14						
Highest CH	1.239	3.003	4.895	9.95	14.146	20.14						

Mode	LTE Band 41 : 26dB BW(MHz)											
BW	5MHz		10MHz		15MHz		20MHz		5MHz	10MHz	15MHz	20MHz
Mod.	QPSK	16QAM	QPSK	16QAM	QPSK	16QAM	QPSK	16QAM	64QAM	64QAM	64QAM	64QAM
Lowest CH	4.945	4.935	9.67	9.89	14.266	14.386	20.02	20.06	4.905	9.67	14.146	20.06
Middle CH	4.845	4.885	9.69	9.75	14.326	14.296	20.10	20.18	4.875	9.75	14.296	20.26
Highest CH	4.895	4.955	9.71	9.93	14.416	14.356	20.02	20.10	4.905	9.77	14.446	20.14



LTE Band 2

Lowest Channel / 1.4MHz / QPSK

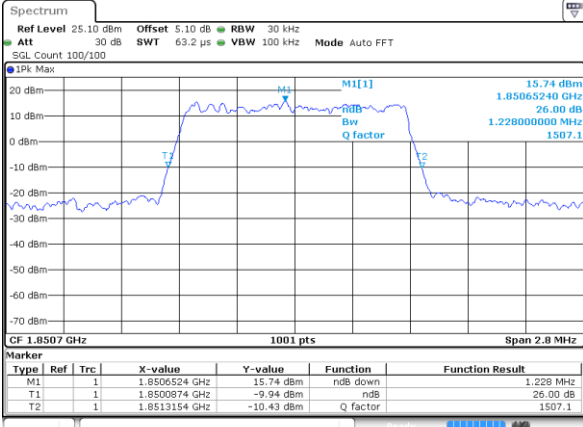

Date: 28 JUN 2017 17:45:17

Lowest Channel / 1.4MHz / 16QAM

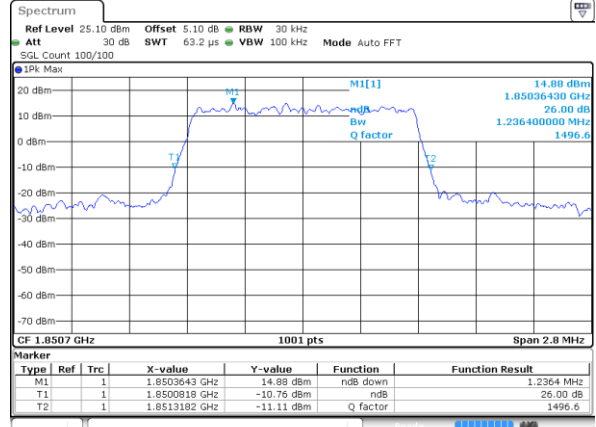

Date: 28 JUN 2017 17:45:27

Middle Channel / 1.4MHz / QPSK

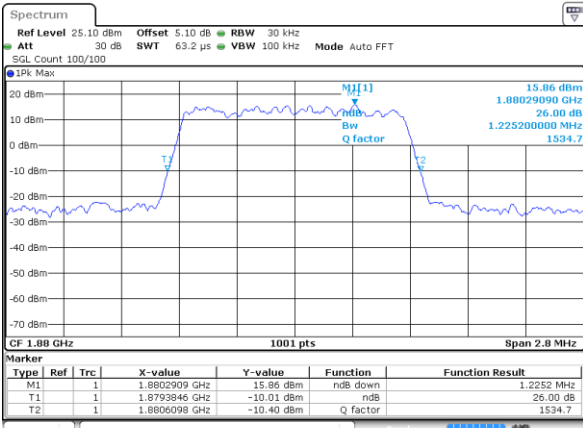

Date: 28 JUN 2017 17:52:15

Middle Channel / 1.4MHz / 16QAM

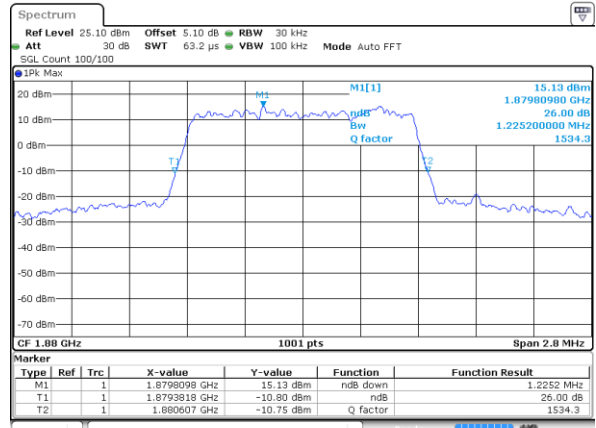

Date: 28 JUN 2017 17:52:25

Highest Channel / 1.4MHz / QPSK

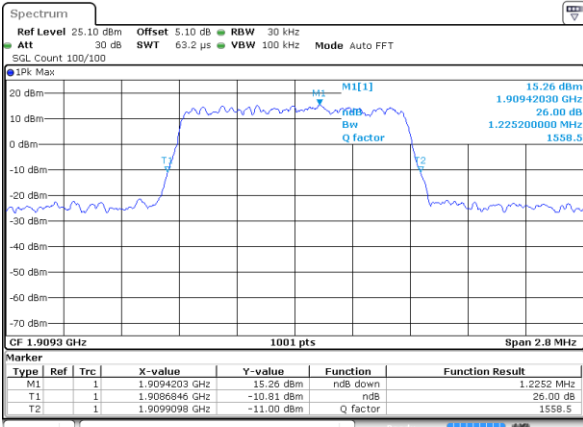

Date: 28 JUN 2017 17:54:44

Highest Channel / 1.4MHz / 16QAM

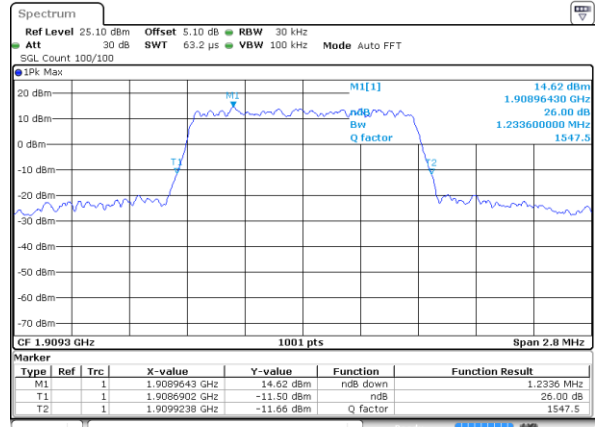

Date: 28 JUN 2017 17:54:54



LTE Band 2

Lowest Channel / 3MHz / QPSK

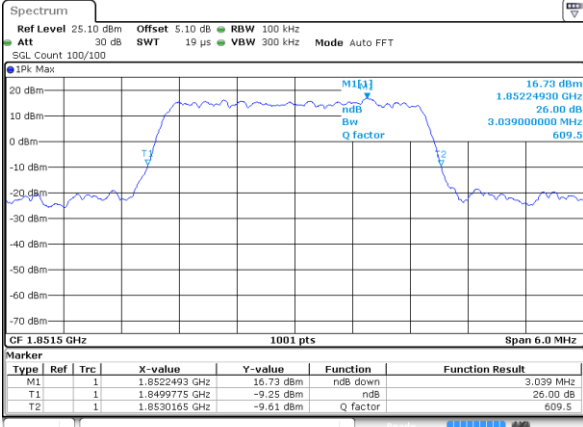

Date: 28 JUN 2017 18 01 42

Lowest Channel / 3MHz / 16QAM

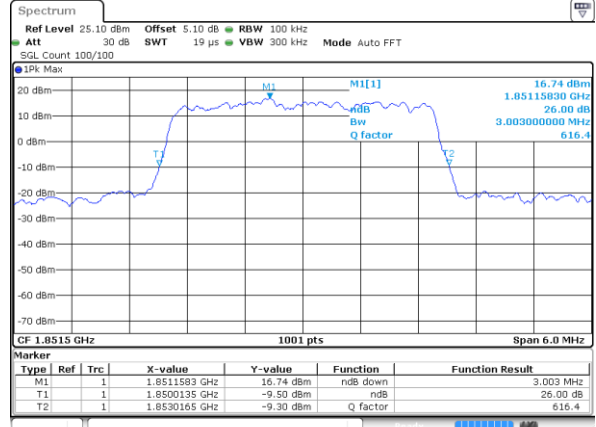

Date: 28 JUN 2017 18 01 52

Middle Channel / 3MHz / QPSK

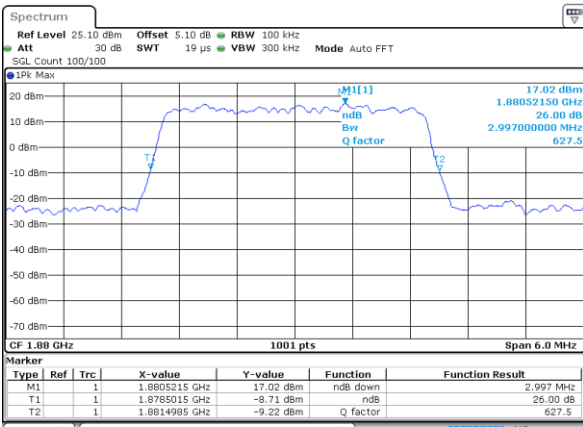

Date: 28 JUN 2017 18 08 41

Middle Channel / 3MHz / 16QAM

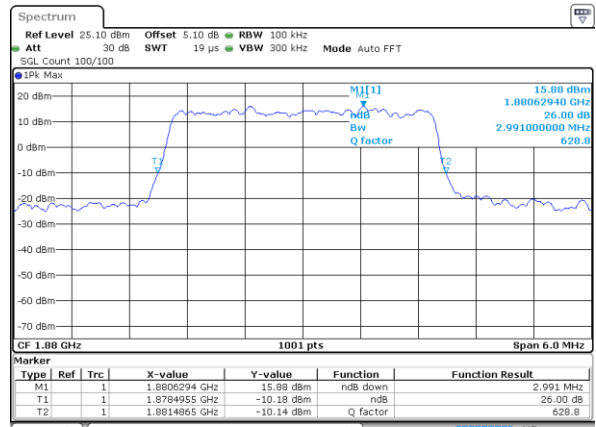

Date: 28 JUN 2017 18 08 50

Highest Channel / 3MHz / QPSK

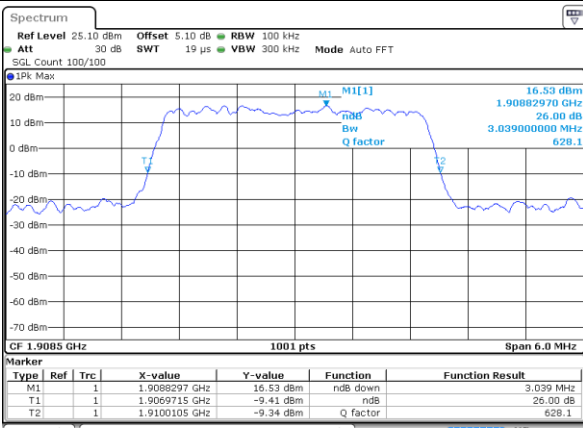

Date: 28 JUN 2017 18 11 09

Highest Channel / 3MHz / 16QAM

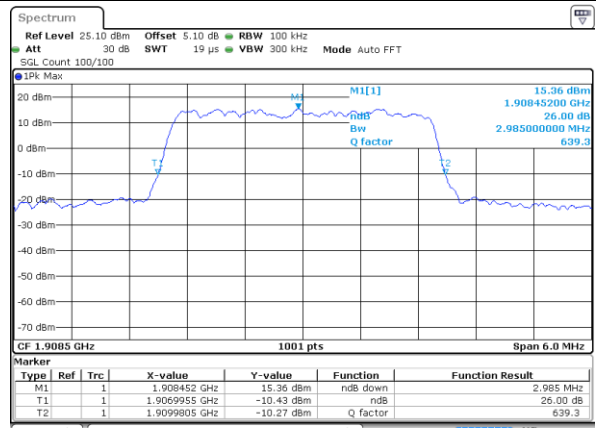

Date: 28 JUN 2017 18 11 19



LTE Band 2

Lowest Channel / 5MHz / QPSK

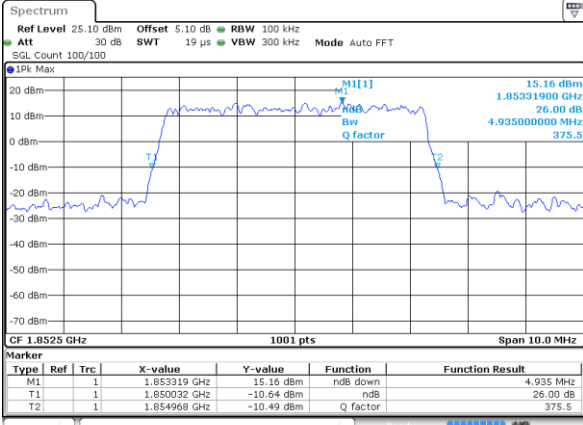

Date: 28 JUN 2017 18:18:08

Lowest Channel / 5MHz / 16QAM

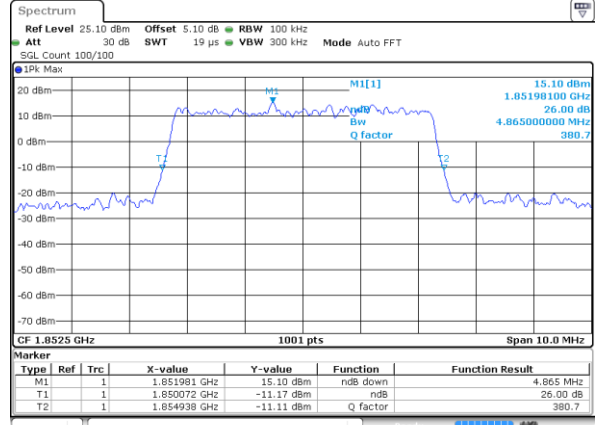

Date: 28 JUN 2017 18:18:18

Middle Channel / 5MHz / QPSK

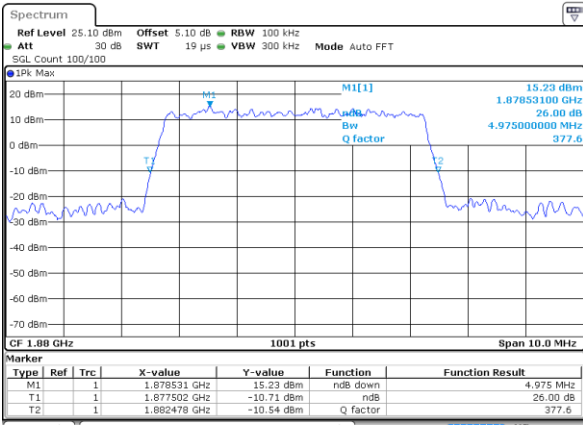

Date: 28 JUN 2017 18:25:06

Middle Channel / 5MHz / 16QAM

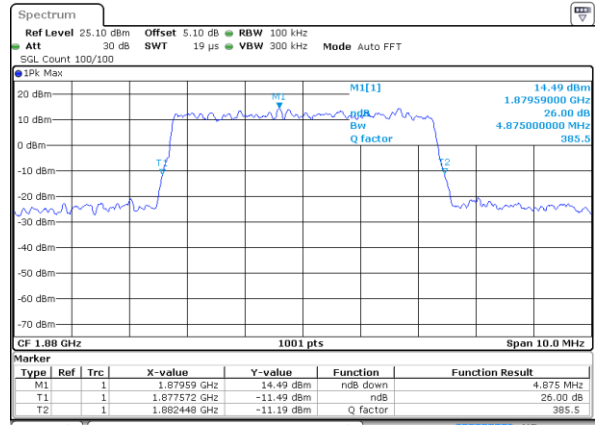

Date: 28 JUN 2017 18:25:16

Highest Channel / 5MHz / QPSK

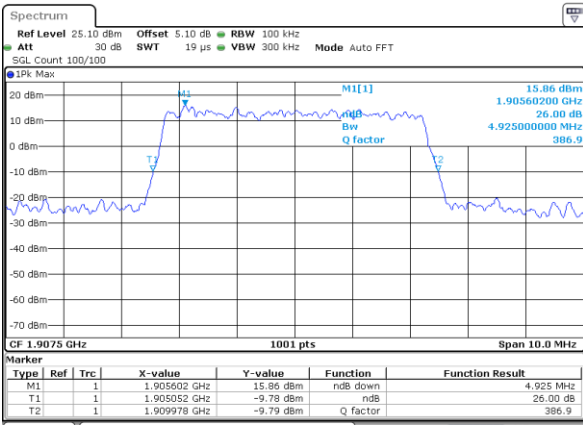

Date: 28 JUN 2017 18:27:35

Highest Channel / 5MHz / 16QAM

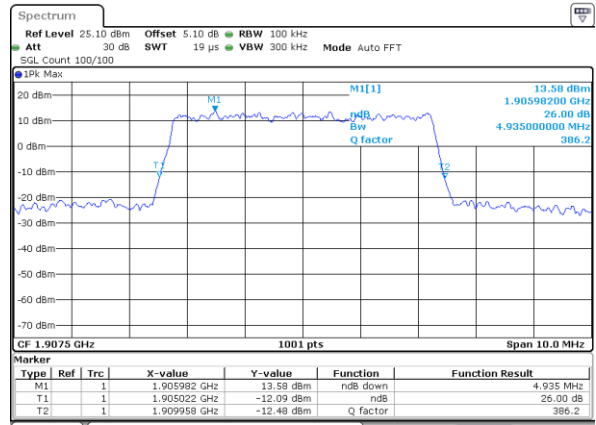

Date: 28 JUN 2017 18:27:45



LTE Band 2

Lowest Channel / 10MHz / QPSK

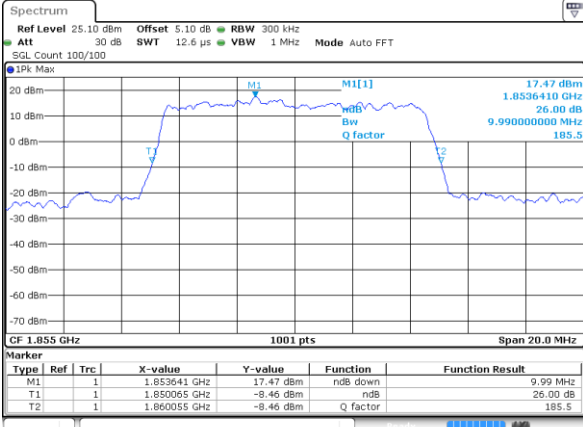

Date: 28 JUN 2017 18:34:33

Lowest Channel / 10MHz / 16QAM

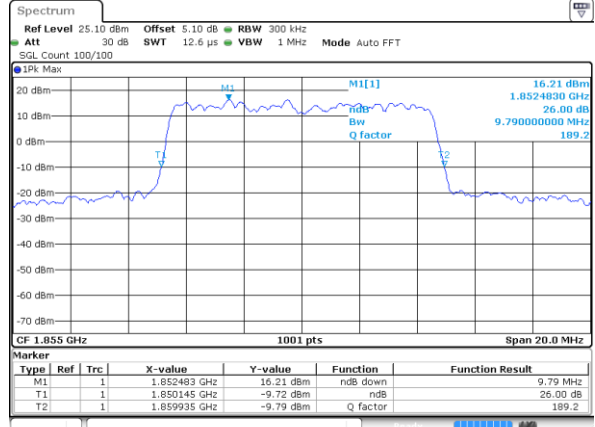

Date: 28 JUN 2017 18:34:43

Middle Channel / 10MHz / QPSK

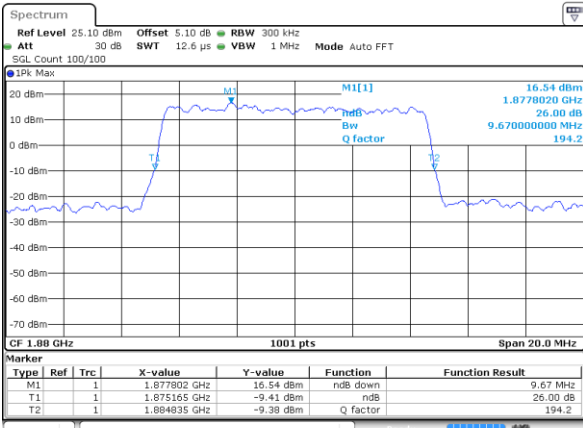

Date: 28 JUN 2017 18:41:31

Middle Channel / 10MHz / 16QAM

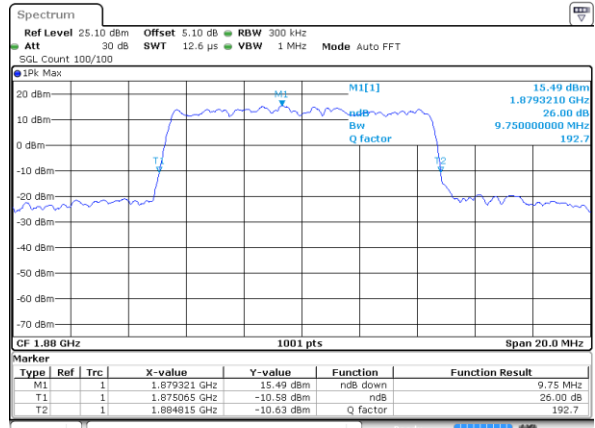

Date: 28 JUN 2017 18:41:41

Highest Channel / 10MHz / QPSK

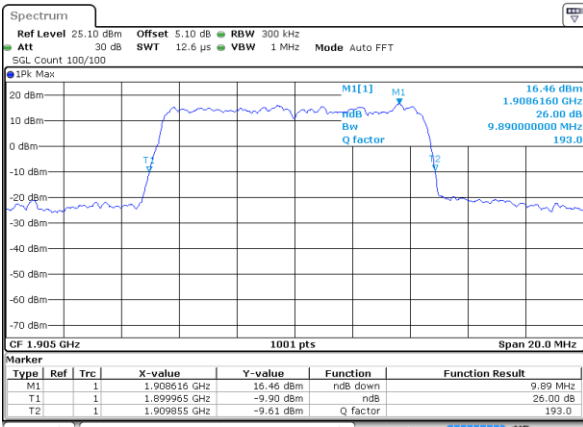

Date: 28 JUN 2017 18:44:00

Highest Channel / 10MHz / 16QAM

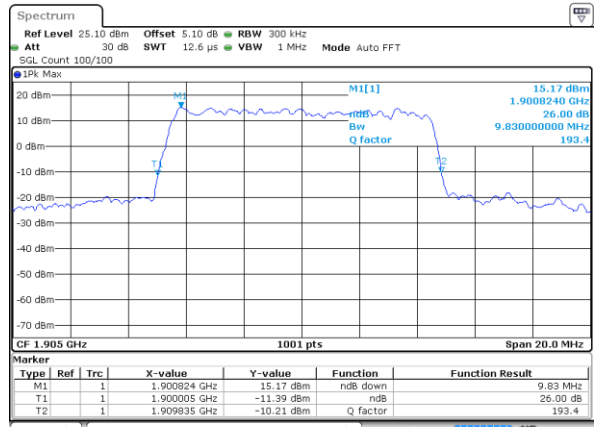

Date: 28 JUN 2017 18:44:10



LTE Band 2

Lowest Channel / 15MHz / QPSK

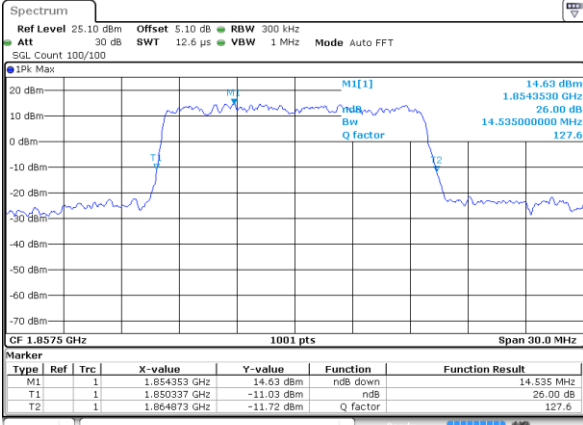

Date: 28 JUN 2017 18:50:58

Lowest Channel / 15MHz / 16QAM

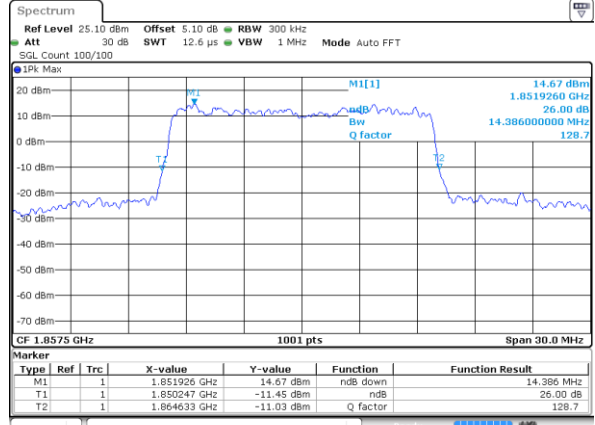

Date: 28 JUN 2017 18:51:08

Middle Channel / 15MHz / QPSK

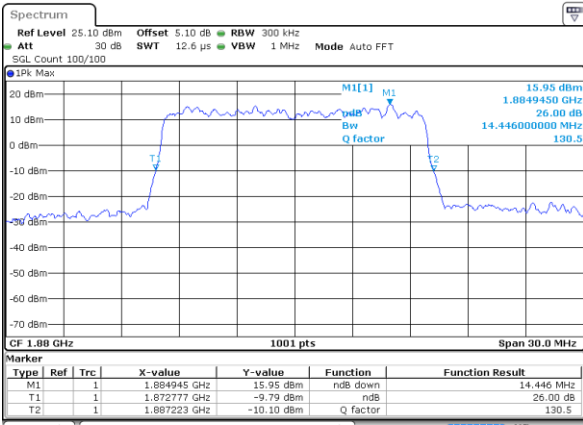

Date: 28 JUN 2017 18:57:57

Middle Channel / 15MHz / 16QAM

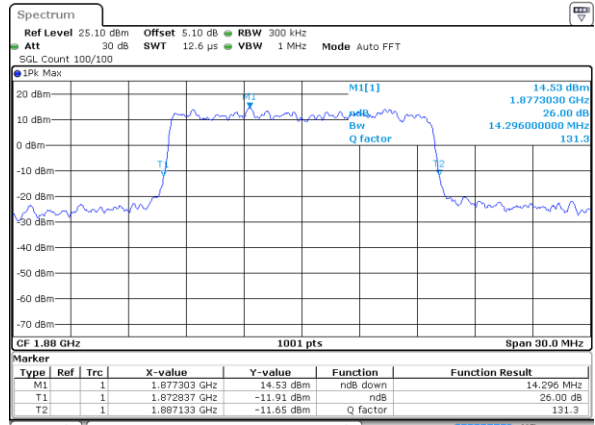

Date: 28 JUN 2017 18:58:06

Highest Channel / 15MHz / QPSK

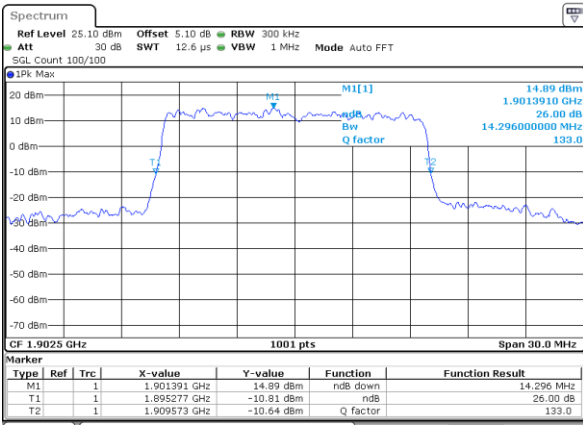

Date: 28 JUN 2017 19:00:25

Highest Channel / 15MHz / 16QAM

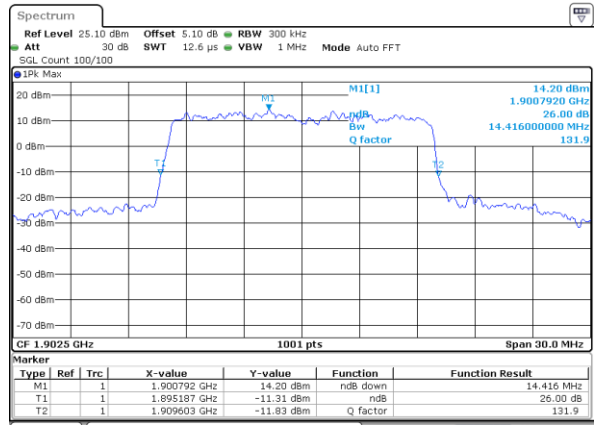

Date: 28 JUN 2017 19:00:35



LTE Band 2

Lowest Channel / 20MHz / QPSK

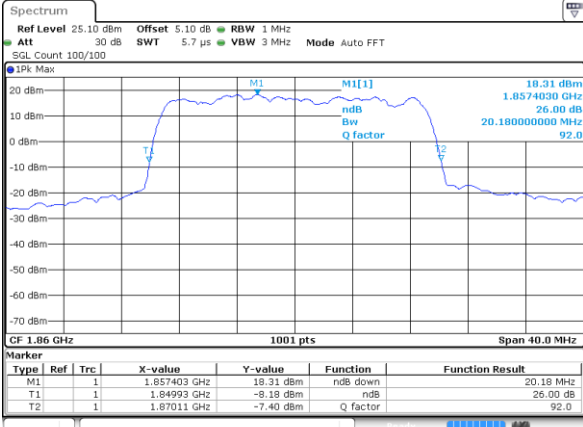

Date: 28 JUN 2017 19:07:24

Lowest Channel / 20MHz / 16QAM

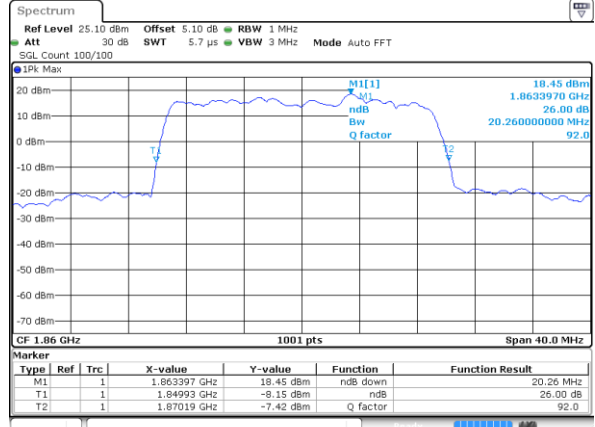

Date: 28 JUN 2017 19:07:33

Middle Channel / 20MHz / QPSK

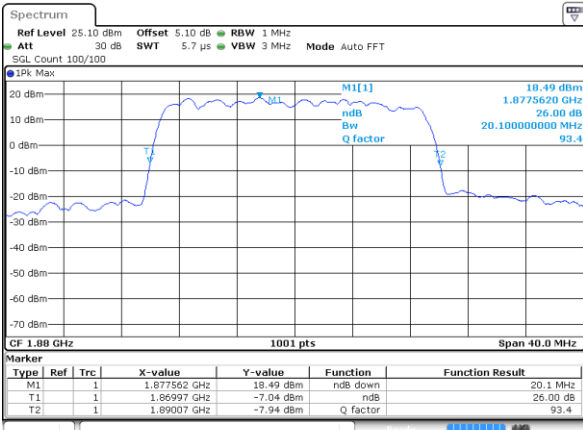

Date: 28 JUN 2017 19:14:22

Middle Channel / 20MHz / 16QAM

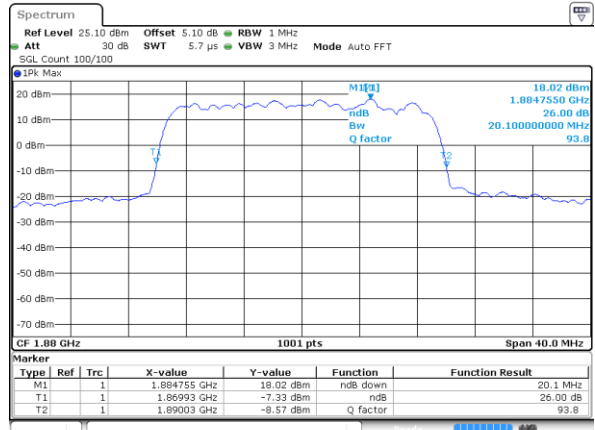

Date: 28 JUN 2017 19:14:32

Highest Channel / 20MHz / QPSK

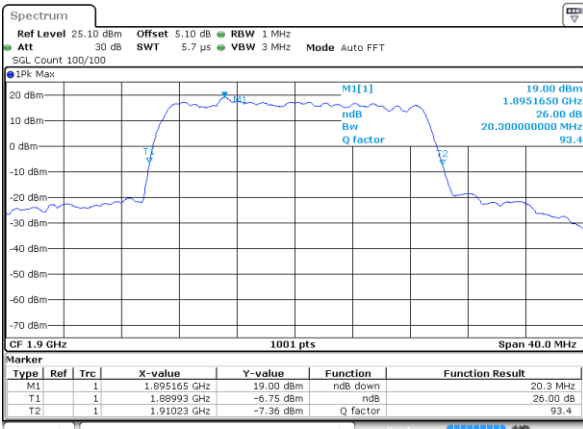

Date: 28 JUN 2017 19:16:51

Highest Channel / 20MHz / 16QAM

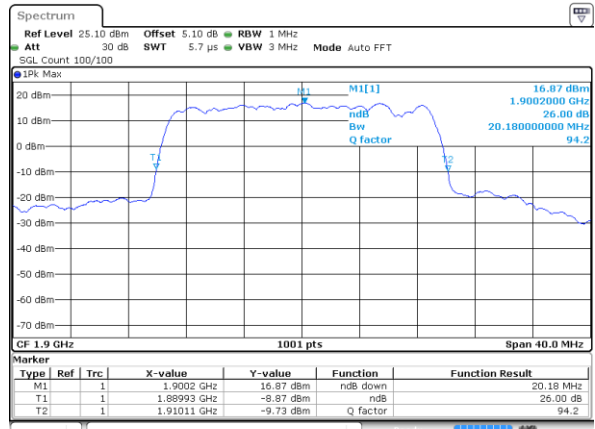

Date: 28 JUN 2017 19:17:01



LTE Band 2

Lowest Channel / 1.4MHz / 64QAM

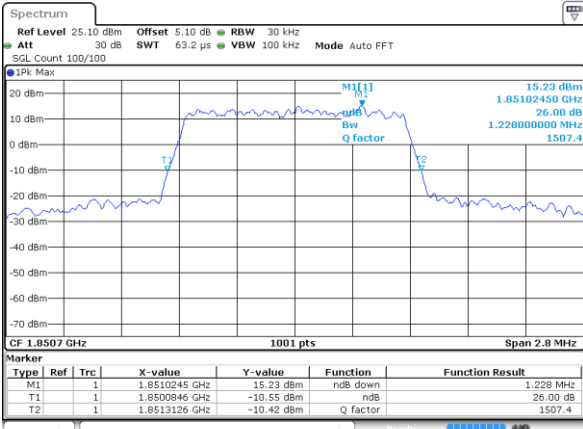

Date: 28 JUN 2017 19:27:07

Lowest Channel / 3MHz / 64QAM

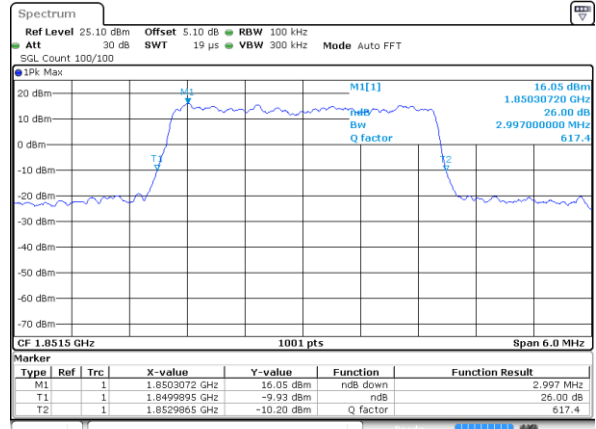

Date: 28 JUN 2017 19:37:56

Middle Channel / 1.4MHz / 64QAM

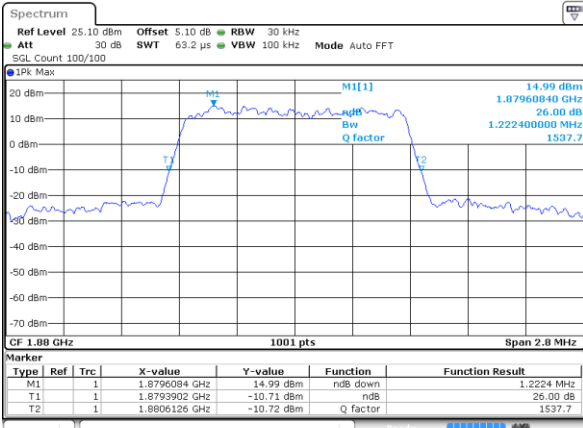

Date: 28 JUN 2017 19:27:45

Middle Channel / 3MHz / 64QAM

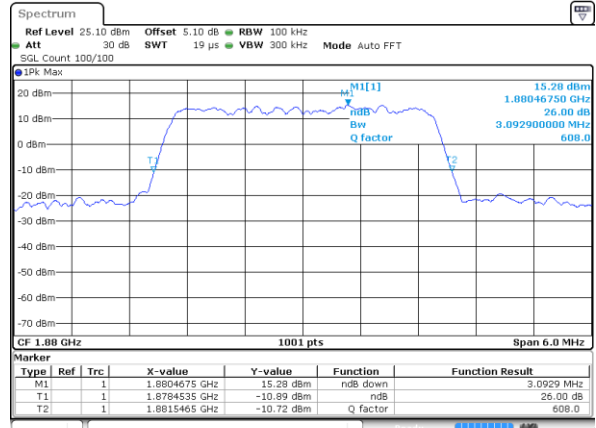

Date: 28 JUN 2017 19:38:23

Highest Channel / 1.4MHz / 64QAM

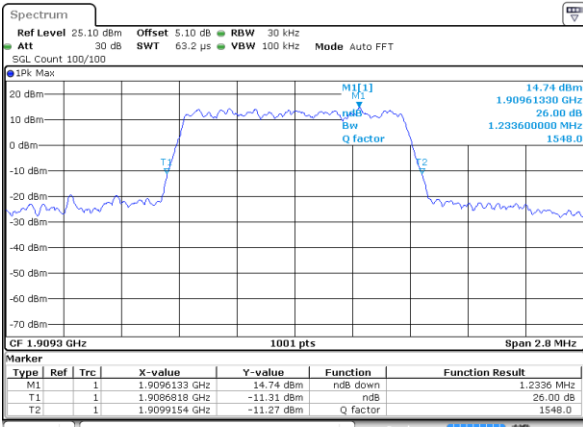

Date: 28 JUN 2017 19:28:13

Highest Channel / 3MHz / 64QAM

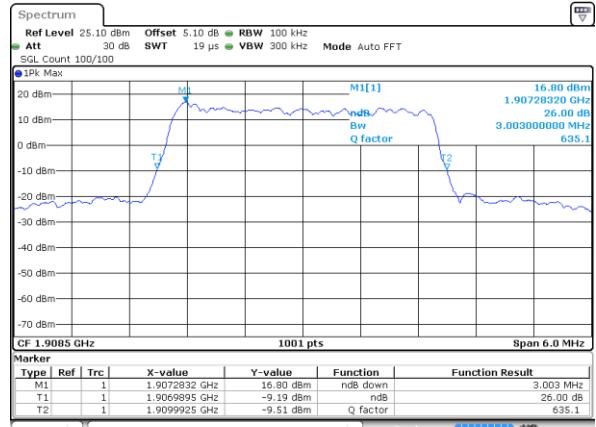

Date: 28 JUN 2017 19:38:45



LTE Band 2

Lowest Channel / 5MHz / 64QAM

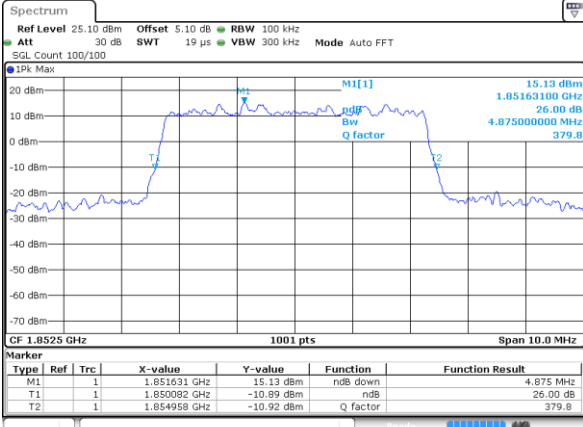

Date: 28 JUN 2017 19:45:05

Lowest Channel / 10MHz / 64QAM

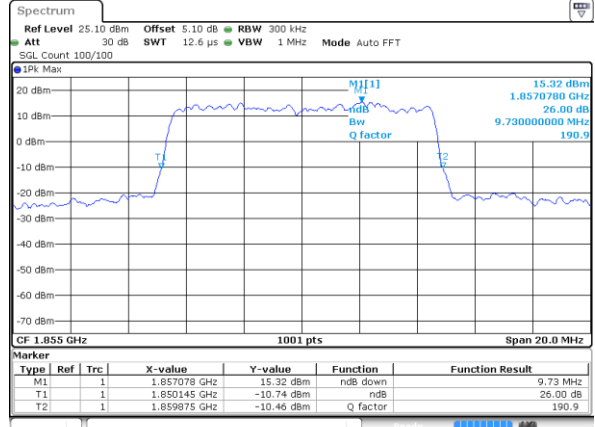

Date: 28 JUN 2017 19:59:42

Middle Channel / 5MHz / 64QAM

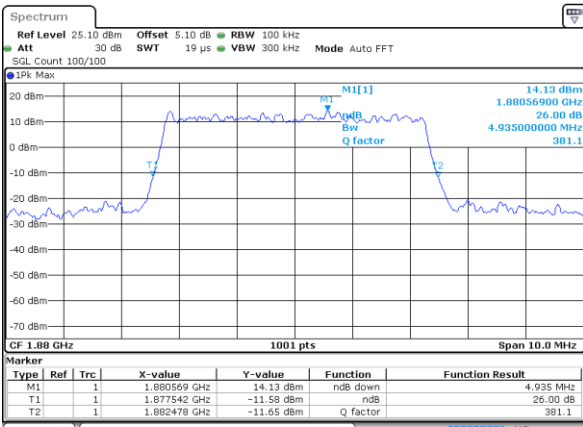

Date: 28 JUN 2017 19:45:27

Middle Channel / 10MHz / 64QAM

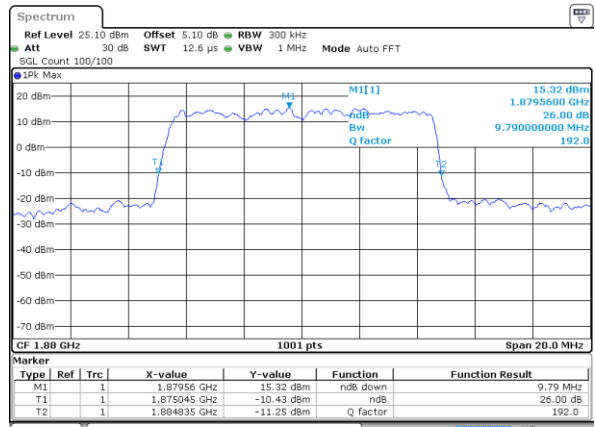

Date: 28 JUN 2017 20:00:07

Highest Channel / 5MHz / 64QAM

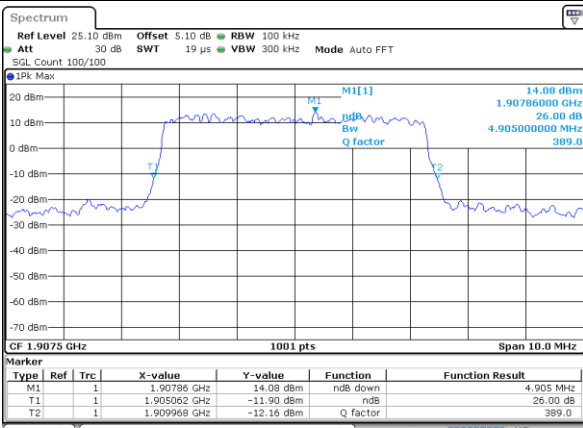

Date: 28 JUN 2017 19:45:58

Highest Channel / 10MHz / 64QAM

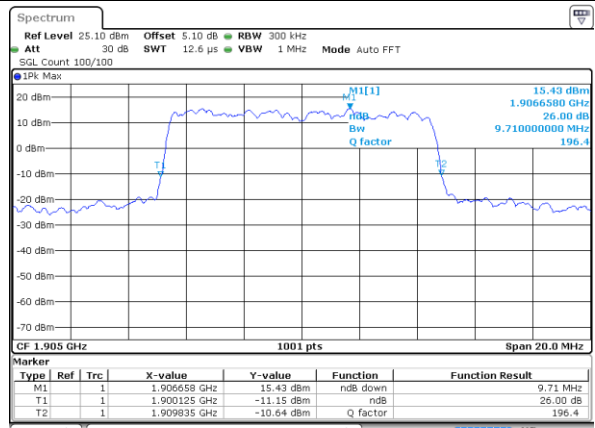

Date: 28 JUN 2017 20:00:28