



FCC RF Test Report

APPLICANT : Motorola Mobility LLC
EQUIPMENT : Mobile Cellular Phone
BRAND NAME : Motorola
MODEL NAME : 10711, 10712
FCC ID : IHDT56WD2
STANDARD : FCC 47 CFR Part 2, 22(H), 24(E), 27(L)
CLASSIFICATION : PCS Licensed Transmitter Held to Ear (PCE)

The product was received on Feb. 13, 2017 and testing was completed on Mar. 14, 2017. We, Sporton International (KunShan) INC., would like to declare that the tested sample has been evaluated in accordance with the test procedures given in ANSI / TIA / EIA-603-D-2010 and has been in compliance with the applicable technical standards.

The test results in this report apply exclusively to the tested model / sample. Without written approval of Sporton International (KunShan) INC., the test report shall not be reproduced except in full.

Prepared by: James Huang / Manager



Approved by: Jones Tsai / Manager

Sporton International (KunShan) INC.

No.3-2, Pingxiang Road, Kunshan Development Zone, Jiangsu, China



TABLE OF CONTENTS

REVISION HISTORY.....4

SUMMARY OF TEST RESULT 5

1 GENERAL DESCRIPTION6

1.1 Applicant..... 6

1.2 Manufacturer 6

1.3 Product Feature of Equipment Under Test 6

1.4 Product Specification of Equipment Under Test 7

1.5 Specification of Accessory 8

1.6 Modification of EUT 8

1.7 Re-use of Measured Data 9

1.8 Maximum EIRP Power, Frequency Tolerance, and Emission Designator..... 10

1.9 Testing Location 11

1.10 Applicable Standards 11

2 TEST CONFIGURATION OF EQUIPMENT UNDER TEST 12

2.1 Test Mode..... 12

2.2 Connection Diagram of Test System 13

2.3 Support Unit used in test configuration 13

2.4 Measurement Results Explanation Example 13

3 CONDUCTED TEST RESULT..... 14

3.1 Measuring Instruments..... 14

3.2 Test Setup 14

3.3 Test Result of Conducted Test..... 14

3.4 Conducted Output Power and EIRP 15

3.5 Peak-to-Average Ratio 16

3.6 99% Occupied Bandwidth and 26dB Bandwidth Measurement..... 17

3.7 Conducted Band Edge 18

3.8 Conducted Spurious Emission 19

3.9 Frequency Stability..... 20

4 RADIATED TEST ITEMS 21

4.1 Measuring Instruments..... 21

4.2 Test Setup 21

4.3 Test Result of Radiated Test..... 21

4.4 Field Strength of Spurious Radiation Measurement 22

5 LIST OF MEASURING EQUIPMENT 23

6 UNCERTAINTY OF EVALUATION 24

APPENDIX A. TEST RESULTS OF CONDUCTED TEST

APPENDIX B. TEST RESULTS OF RADIATED TEST

APPENDIX C. TEST SETUP PHOTOGRAPHS



APPENDIX D. REFERENCE REPORT



SUMMARY OF TEST RESULT

Report Section	FCC Rule	Description	Limit	Result	Remark
3.4	§2.1046	Conducted Output Power	Reporting Only	PASS	-
	§27.50(d)(4)	Equivalent Isotropic Radiated Power	< 1 Watts	PASS	-
3.5	N/A	Peak-to-Average Ratio	Reporting Only	PASS	-
3.6	§2.1049 §27.53(g)	Occupied Bandwidth	Reporting Only	PASS	-
3.7	§2.1051 §27.53(h)	Band Edge Measurement	< 43+10log10(P[Watts])	PASS	-
3.8	§2.1051 §27.53(h)	Conducted Emission	< 43+10log10(P[Watts])	PASS	-
3.9	§2.1055 §27.54	Frequency Stability for Temperature & Voltage	Within Authorized Band	PASS	-
4.4	§2.1053 §27.53(h)	Field Strength of Spurious Radiation	< 43+10log10(P[Watts])	PASS	Under limit 46.05 dB at 5197.800 MHz



1 General Description

1.1 Applicant

Motorola Mobility LLC
222 W, Merchandise Mart Plaza, Chicago IL 60654 USA

1.2 Manufacturer

Motorola Mobility LLC
222 W, Merchandise Mart Plaza, Chicago IL 60654 USA

1.3 Product Feature of Equipment Under Test

Product Feature	
Equipment	Mobile Cellular Phone
Brand Name	Motorola
Model Name	10711, 10712
FCC ID	IHDT56WD2
EUT supports Radios application	GSM/GPRS/EGPRS/WCDMA/HSPA/HSPA+/ DC-HSDPA/LTE/ WLAN2.4GHz 802.11b/g/n HT20/ Bluetooth v3.0+EDR/ Bluetooth v4.0 LE/Bluetooth v4.1 LE/Bluetooth v4.2 LE
IMEI Code	Conducted: 355635080022837/355635080031481 Radiation: 355636080002977/355636080002927
HW Version	B4-3
SW Version	nicklaus_oem_userdebug_7.0_NMA25.11_122_intcfg-test-keys_oem
EUT Stage	Identical Prototype

Remark:

1. The above EUT's information was declared by manufacturer. Please refer to the specifications or user's manual for more detailed description.
2. There are two types of EUT sample 1 and sample 2, the differences between two samples are only for SIM slot, sample 1 is dual SIM slot, sample 2 is single SIM slot. According to the difference, the sample 1 to perform full test.
3. After pre-scan two SIM cards power, we found test result of the SIM1 was the worse, so we chose dual SIM1 card to perform all tests.



1.4 Product Specification of Equipment Under Test

Standards-related Product Specification	
Tx Frequency	GSM/GPRS/EDGE: 850: 824.2 MHz ~ 848.8 MHz 1900: 1850.2 MHz ~ 1909.8MHz WCDMA: Band V: 826.4 MHz ~ 846.6 MHz Band II: 1852.4 MHz ~ 1907.6 MHz Band IV: 1712.4 MHz ~ 1752.6 MHz
Rx Frequency	GSM/GPRS/EDGE: 850: 869.2 MHz ~ 893.8 MHz 1900: 1930.2 MHz ~ 1989.8 MHz WCDMA: Band V: 871.4 MHz ~ 891.6 MHz Band II: 1932.4 MHz ~ 1987.6 MHz Band IV: 2112.4 MHz ~ 2152.6 MHz
Maximum Output Power to Antenna	Band IV: 22.91 dBm
Antenna Type	LDS Antenna
Antenna Gain	AWS Band: -2.40 dBi
Type of Modulation	GSM: GMSK GPRS: GMSK EDGE: GMSK / 8PSK WCDMA : BPSK (Uplink) HSDPA/DC-HSDPA : QPSK (Uplink) HSUPA : QPSK (Uplink) HSPA+ : 16QAM DC-HSDPA : 64QAM

1.5 Specification of Accessory

Specification of Accessory				
AC Adapter (EU)	Brand Name	Motorola (AcBel)	Model Name	C-P36 SPN5944A
	Power Rating	I/P: 100 - 240 Vac, 0.3 A, O/P: 5.2 Vdc, 2.0 A		
AC Adapter (UK)	Brand Name	Motorola (AcBel)	Model Name	C-P37 SPN5940A
	Power Rating	I/P: 100 - 240 Vac, 0.3 A, O/P: 5.2 Vdc, 2.0 A		
AC Adapter (US)	Brand Name	Motorola (AcBel)	Model Name	C-P35 SPN5945A
	Power Rating	I/P: 100 - 240 Vac, 0.3 A, O/P: 5.2 Vdc, 2.0 A		
AC Adapter (IN)	Brand Name	Motorola (AcBel)	Model Name	C-P49 SPN5946A
	Power Rating	I/P: 100 - 240 Vac, 0.3 A, O/P: 5.2 Vdc, 2.0 A		
AC Adapter (AR)	Brand Name	Motorola (AcBel)	Model Name	C-P47 SPN5942A
	Power Rating	I/P: 100 - 240 Vac, 0.5 A, O/P: 5.2 Vdc, 2.0 A		
Battery	Brand Name	Motorola (Amperex)	Model Name	HE50
	Power Rating	0.38 Vdc, 5000 mAh	Type	Li-ion
USB Cable	Brand Name	Motorola (Li Qi)	Model Name	LQ-035050
	Signal Line Type	1.0m shielded cable without core		
Earphone 1	Brand Name	Motorola (Tenji)	Model Name	TJ-101814
	Signal Line Type	1.2m unshielded cable without core		
Earphone 2	Brand Name	Motorola(Cosonic)	Model Name	SH38C16617
	Signal Line Type	1.1m unshielded cable without core		

1.6 Modification of EUT

No modifications are made to the EUT during all test items.



1.7 Re-use of Measured Data

1.7.1 Introduction Section

This application re-uses data collected on a similar device. The subject device of this application (Model: 10711, 10712, FCC ID: IHDT56WD2) is electrically identical to the reference device (Model: 10710, FCC ID: IHDT56WD3) for the portions of the circuitry corresponding to the data being re-used, as treated by KDB Publication 178919 D01.

1.7.2 Difference Section

For details concerning the similarity with respect to component placement, mechanical/electrical design etc., please refer to the product equality declaration as Appendix D.

The re-used RF data includes the following bands provided in Appendix E (Sporton RF Report No. FG721309A for the reference device Model: Model: 10710, FCC ID: IHDT56WD3):

1.7.3 Spot Check Verification Data Section

In order to confirm hardware similarity of the subject device with the reference device, spot check measurements were performed on the subject device for radiated spurious emission, Conducted Band-edge and Conducted spurious emission, the test result were consistent with FCC ID: IHDT56WD3. And adding a new band of WCDMA Band IV to perform full test.

Assertions concerning the similarity of these devices are based on representations by the applicant. The applicant accepts full responsibility for the validity of the similarity claim, and for the determination that verification test data are sufficient to support it.

1.7.4 Reference detail Section:

Equipment Class	Reference FCC ID	Folder Test/RF Exposure	Report Title/Section
PCE	IHDT56WD3	Part22H.24E (FG721309A)	All sections applicable



1.8 Maximum EIRP Power, Frequency Tolerance, and Emission Designator

FCC Rule	System	Type of Modulation	Maximum EIRP (W)	Frequency Tolerance (ppm)	Emission Designator
Part 27L	WCDMA Band IV RMC 12.2Kbps	BPSK	0.1125	0.0202 ppm	4M21F9W



1.9 Testing Location

Test Site	Sporton International (KunShan) INC.		
Test Site Location	No.3-2, Pingxiang Road, Kunshan Development Zone, Jiangsu, China TEL: +86-0512-5790-0158 FAX: +86-0512-5790-0958		
Test Site No.	Sporton Site No.		FCC Registration No.
	TH01-KS	03CH03-KS	306251

1.10 Applicable Standards

According to the specifications of the manufacturer, the EUT must comply with the requirements of the following standards:

- 47 CFR Part 2, 22(H), 24(E), 27(L)
- ANSI / TIA / EIA-603-D-2010
- FCC KDB 971168 D01 Power Meas. License Digital Systems v02r02
- FCC KDB 412172 D01 Determining ERP and EIRP v01r01

Remark:

1. All test items were verified and recorded according to the standards and without any deviation during the test.
2. This EUT has also been tested and complied with the requirements of FCC Part 15, Subpart B, recorded in a separate test report.



2 Test Configuration of Equipment Under Test

2.1 Test Mode

Antenna port conducted and radiated test items were performed according to KDB 971168 D01 Power Meas. License Digital Systems v02r02 with maximum output power.

Radiated measurements were performed with rotating EUT in different three orthogonal test planes to find the maximum emission.

Radiated emissions were investigated as following frequency range:

1. 30 MHz to 10th harmonic MHz for WCDMA Band IV.

All modes and data rates and positions were investigated.

Test modes are chosen to be reported as the worst case configuration below:

Test Modes		
Band	Radiated TCs	Conducted TCs
WCDMA Band IV	■ RMC 12.2Kbps Link	■ RMC 12.2Kbps Link

2.2 Connection Diagram of Test System

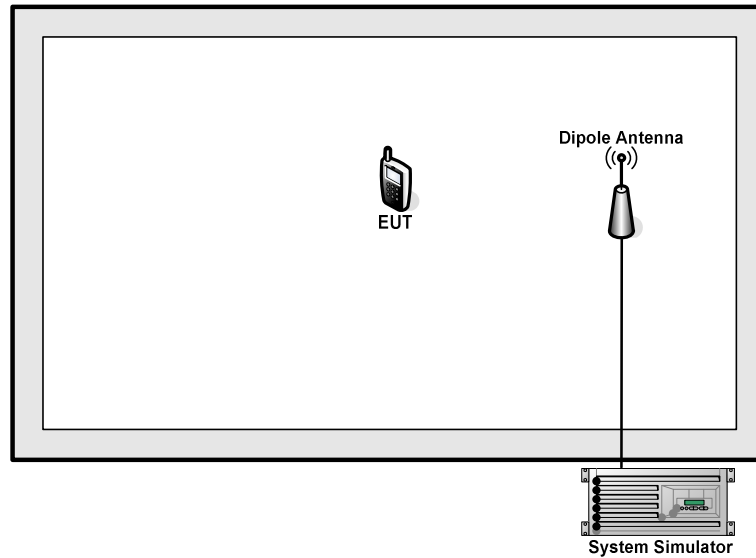

2.3 Support Unit used in test configuration

Item	Equipment	Trade Name	Model No.	FCC ID	Data Cable	Power Cord
1.	System Simulator	Anritsu	MT8820C	N/A	N/A	Unshielded, 1.8 m
2.	DC Power Supply	GW INSTRON	GPS-3030D	N/A	N/A	Unshielded, 1.8 m

2.4 Measurement Results Explanation Example

For all conducted test items:

The offset level is set in the spectrum analyzer to compensate the RF cable loss and attenuator factor between RF conducted output port and spectrum analyzer. With the offset compensation, the spectrum analyzer reading level will be exactly the RF output level.

The spectrum analyzer offset is derived from RF cable loss and attenuator factor.

Offset = RF cable loss + attenuator factor.

The following shows an offset computation example with RF cable loss 5.3 dB and a 10dB attenuator.

Example :

$$\begin{aligned} \text{Offset(dB)} &= \text{RF cable loss(dB)} + \text{attenuator factor(dB)}. \\ &= 5.3 + 10 = 15.3 \text{ (dB)} \end{aligned}$$

3 Conducted Test Result

3.1 Measuring Instruments

See list of measuring instruments of this test report.

3.2 Test Setup

3.2.1 Conducted Output Power



3.2.2 Peak-to-Average Ratio, Occupied Bandwidth, Conducted Band-Edge and Conducted Spurious Emission

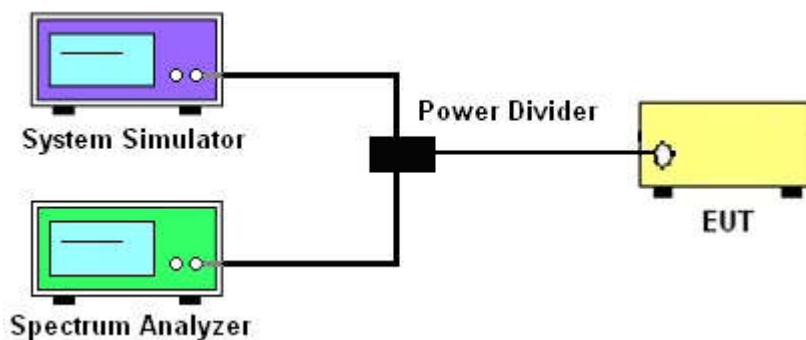

3.2.3 Frequency Stability

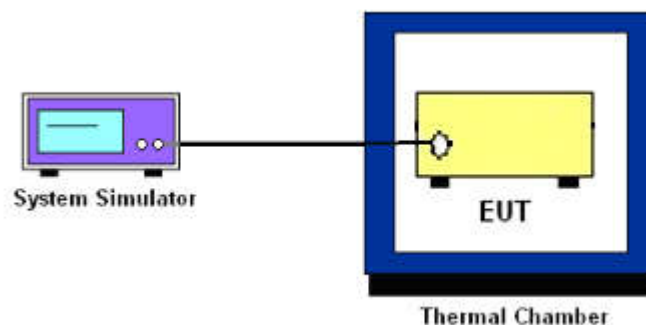

3.3 Test Result of Conducted Test

Please refer to Appendix A.



3.4 Conducted Output Power and EIRP

3.4.1 Description of the Conducted Output Power and EIRP

A system simulator was used to establish communication with the EUT. Its parameters were set to enforce EUT transmitting at the maximum power. The measured power in the radio frequency on the transmitter output terminals shall be reported.

The EIRP of mobile transmitters must not exceed 1 Watts for WCDMA Band IV.

According to KDB 412172 D01 Power Approach,

$EIRP = P_T + G_T - L_C$, $ERP = EIRP - 2.15$, where

P_T = transmitter output power in dBm

G_T = gain of the transmitting antenna in dBi

L_C = signal attenuation in the connecting cable between the transmitter and antenna in dB

3.4.2 Test Procedures

1. The transmitter output port was connected to the system simulator.
2. Set EUT at maximum power through system simulator.
3. Select lowest, middle, and highest channels for each band and different modulation.
4. Measure the maximum burst average power for WCDMA.



3.5 Peak-to-Average Ratio

3.5.1 Description of the PAR Measurement

The peak-to-average ratio (PAR) of the transmission may not exceed 13 dB.

3.5.2 Test Procedures

1. The testing follows FCC KDB 971168 D01 v02r02 Section 5.7.1.
2. The EUT was connected to spectrum analyzer and system simulator via a power divider.
3. Set EUT to transmit at maximum output power.
4. When the duty cycle is less than 98%, then signal gating will be implemented on the spectrum analyzer by triggering from the system simulator.
5. Set the CCDF (Complementary Cumulative Distribution Function) option of the spectrum analyzer.
Record the maximum PAPR level associated with a probability of 0.1%.



3.6 99% Occupied Bandwidth and 26dB Bandwidth Measurement

3.6.1 Description of 99% Occupied Bandwidth and 26dB Bandwidth Measurement

The occupied bandwidth is the width of a frequency band such that, below the lower and above the upper frequency limits, the mean powers emitted are each equal to a specified percentage 0.5% of the total mean transmitted power.

The 26 dB emission bandwidth is defined as the frequency range between two points, one above and one below the carrier frequency, at which the spectral density of the emission is attenuated 26 dB below the maximum in-band spectral density of the modulated signal. Spectral density (power per unit bandwidth) is to be measured with a detector of resolution bandwidth equal to approximately 1.0% of the emission bandwidth.

3.6.2 Test Procedures

1. The testing follows FCC KDB 971168 v02r02 Section 4.2.
2. The EUT was connected to spectrum analyzer and system simulator via a power divider.
3. The spectrum analyzer center frequency is set to the nominal EUT channel center frequency. The span range for the spectrum analyzer shall be between two and five times the anticipated OBW.
4. The nominal resolution bandwidth (RBW) shall be in the range of 1 to 5 % of the anticipated OBW, and the VBW shall be at least 3 times the RBW.
5. Set the detection mode to peak, and the trace mode to max hold.
6. Determine the reference value: Set the EUT to transmit a modulated signal. Allow the trace to stabilize. Set the spectrum analyzer marker to the highest level of the displayed trace.
(this is the reference value)
7. Determine the “-26 dB down amplitude” as equal to (Reference Value – X).
8. Place two markers, one at the lowest and the other at the highest frequency of the envelope of the spectral display such that each marker is at or slightly below the “-X dB down amplitude” determined in step 6. If a marker is below this “-X dB down amplitude” value it shall be placed as close as possible to this value. The OBW is the positive frequency difference between the two markers.
9. Use the 99 % power bandwidth function of the spectrum analyzer and report the measured bandwidth.



3.7 Conducted Band Edge

3.7.1 Description of Conducted Band Edge Measurement

The power of any emission outside of the authorized operating frequency ranges must be lower than the transmitter power (P) by a factor of at least $43 + 10 \log (P)$ dB.

3.7.2 Test Procedures

1. The testing follows FCC KDB 971168 D01 v02r02 Section 6.0.
2. The EUT was connected to the spectrum analyzer and system simulator via a power divider.
3. The RF output of EUT was connected to the spectrum analyzer by an RF cable and attenuator. The path loss was compensated to the results for each measurement.
4. The band edges of low and high channels for the highest RF powers were measured.
5. The RF fundamental frequency should be excluded against the limit line in the operating frequency band.
6. The limit line is derived from $43 + 10\log(P)$ dB below the transmitter power P(Watts)
 $= P(W) - [43 + 10\log(P)]$ (dB)
 $= [30 + 10\log(P)]$ (dBm) - $[43 + 10\log(P)]$ (dB)
 $= -13\text{dBm}$.



3.8 Conducted Spurious Emission

3.8.1 Description of Conducted Spurious Emission Measurement

The power of any emission outside of the authorized operating frequency ranges must be lower than the transmitter power (P) by a factor of at least $43 + 10 \log (P)$ dB.

It is measured by means of a calibrated spectrum analyzer and scanned from 9kHz up to a frequency including its 10th harmonic.

3.8.2 Test Procedures

1. The testing follows FCC KDB 971168 D01 v02r02 Section 6.0.
2. The EUT was connected to the spectrum analyzer and system simulator via a power divider.
3. The RF output of EUT was connected to the spectrum analyzer by an RF cable and attenuator. The path loss was compensated to the results for each measurement.
4. The middle channel for the highest RF power within the transmitting frequency was measured.
5. The conducted spurious emission for the whole frequency range was taken.
6. The RF fundamental frequency should be excluded against the limit line in the operating frequency band.
7. The limit line is derived from $43 + 10\log(P)$ dB below the transmitter power P(Watts)
= $P(W) - [43 + 10\log(P)]$ (dB)
= $[30 + 10\log(P)]$ (dBm) - $[43 + 10\log(P)]$ (dB)
= -13dBm.



3.9 Frequency Stability

3.9.1 Description of Frequency Stability Measurement

The frequency stability shall be measured by variation of ambient temperature and variation of primary supply voltage to ensure that the fundamental emission stays within the authorized frequency block. The frequency stability of the transmitter shall be maintained within $\pm 0.00025\%$ ($\pm 2.5\text{ppm}$) of the center frequency.

3.9.2 Test Procedures for Temperature Variation

1. The testing follows FCC KDB 971168 D01 v02r02 Section 9.0.
2. The EUT was set up in the thermal chamber and connected with the system simulator.
3. With power OFF, the temperature was decreased to -30°C and the EUT was stabilized before testing. Power was applied and the maximum change in frequency was recorded within one minute.
4. With power OFF, the temperature was raised in 10°C steps up to 50°C . The EUT was stabilized at each step for at least half an hour. Power was applied and the maximum frequency change was recorded within one minute.

3.9.3 Test Procedures for Voltage Variation

1. The testing follows FCC KDB 971168 D01 v02r02 Section 9.0.
2. The EUT was placed in a temperature chamber at $20\pm 5^{\circ}\text{C}$ and connected with the system simulator.
3. The power supply voltage to the EUT was varied from 85% to 115% of the nominal value measured at the input to the EUT.
4. The variation in frequency was measured for the worst case.

4 Radiated Test Items

4.1 Measuring Instruments

See list of measuring instruments of this test report.

4.2 Test Setup

4.2.1 For radiated test from 30MHz to 1GHz

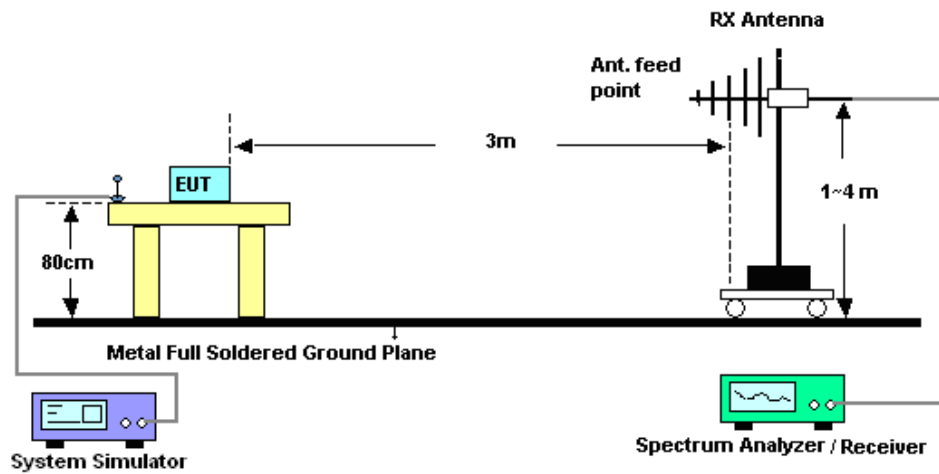

4.2.2 For radiated test above 1GHz

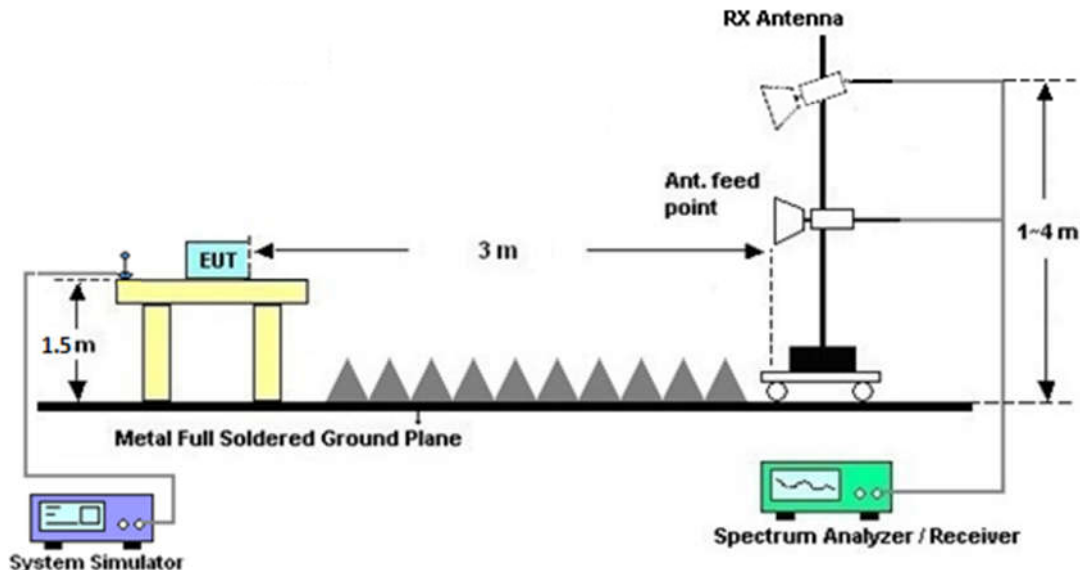

4.3 Test Result of Radiated Test

Please refer to Appendix B.



4.4 Field Strength of Spurious Radiation Measurement

4.4.1 Description of Field Strength of Spurious Radiated Measurement

The power of any emission outside of the authorized operating frequency ranges must be attenuated below the transmitter power (P) by a factor of at least $43 + 10 \log (P)$ dB. The spectrum is scanned from 30 MHz up to a frequency including its 10th harmonic.

4.4.2 Test Procedures

1. The testing follows FCC KDB 971168 D01 v02r02 Section 5.8 and ANSI / TIA-603-D-2010 Section 2.2.12.
2. The EUT was placed on a rotatable wooden table 0.8 meters for frequency below 1GHz and 1.5 meter for frequency above 1GHz above the ground.
3. The EUT was set 3 meters from the receiving antenna, which was mounted on the antenna tower.
4. The table was rotated 360 degrees to determine the position of the highest spurious emission.
5. The height of the receiving antenna is varied between one meter and four meters to search for the maximum spurious emission for both horizontal and vertical polarizations.
6. Make the measurement with the spectrum analyzer's RBW = 1MHz, VBW = 3MHz, taking record of maximum spurious emission.
7. A horn antenna was substituted in place of the EUT and was driven by a signal generator.
8. Tune the output power of signal generator to the same emission level with EUT maximum spurious emission.
9. Taking the record of output power at antenna port.
10. Repeat step 7 to step 8 for another polarization.
11. $EIRP \text{ (dBm)} = S.G. \text{ Power} - Tx \text{ Cable Loss} + Tx \text{ Antenna Gain}$
12. $ERP \text{ (dBm)} = EIRP - 2.15$
13. The RF fundamental frequency should be excluded against the limit line in the operating frequency band.
14. The limit line is derived from $43 + 10\log(P)$ dB below the transmitter power P(Watts)
 $= P(W) - [43 + 10\log(P)] \text{ (dB)}$
 $= [30 + 10\log(P)] \text{ (dBm)} - [43 + 10\log(P)] \text{ (dB)}$
 $= -13\text{dBm}.$



5 List of Measuring Equipment

Instrument	Manufacturer	Model No.	Serial No.	Characteristics	Calibration Date	Test Date	Due Date	Remark
Spectrum Analyzer	R&S	FSV40	101040	10Hz~40GHz	Aug. 09, 2016	Mar. 14, 2017	Aug. 08, 2017	Conducted (TH01-KS)
Thermal Chamber	Ten Billion	TTC-B3S	TBN-960502	-40~+150°C	Oct. 13, 2016	Mar. 14, 2017	Oct. 12, 2017	Conducted (TH01-KS)
Radio communication	Anritsu	MT8820C	6201300652	2G/3G/LTE Band	Aug. 08, 2016	Mar. 14, 2017	Aug. 07, 2017	Conducted (TH01-KS)
EXA Spectrum Analyzer	Keysight	N9010A	MY55150244	10Hz~44GHz	Apr. 22, 2016	Mar. 03, 2017	Apr. 21, 2017	Radiation (03CH03-KS)
Bilog Antenna	TeseQ	CBL6112D	35406	25MHz~2GHz	Apr. 16, 2016	Mar. 03, 2017	Apr. 15, 2017	Radiation (03CH03-KS)
Horn Antenna	Schwarzbeck	BBHA9120D	9120D-1356	1GHz~18GHz	Apr. 16, 2016	Mar. 03, 2017	Apr. 15, 2017	Radiation (03CH03-KS)
SHF-EHF Horn	Schwarzbeck	BBHA 9170	BBHA170249	15GHz~40GHz	Feb. 15, 2017	Mar. 03, 2017	Feb. 14, 2018	Radiation (03CH03-KS)
Amplifier	SONOMA	310N	187289	9kHz~1GHz	Aug. 09, 2016	Mar. 03, 2017	Aug. 08, 2017	Radiation (03CH03-KS)
High Gain Amplifier	MITEQ	AMF-7D-00 101800-30-1 0P	1943529	1GHz~18GHz	Jan. 19, 2017	Mar. 03, 2017	Jan. 18, 2018	Radiation (03CH03-KS)
Amplifier	Agilent	8449B	3008A02370	1GHz~26.5GHz	Oct. 13, 2016	Mar. 03, 2017	Oct. 12, 2017	Radiation (03CH03-KS)
AC Power Source	Chroma	61601	F104090004	N/A	NCR	Mar. 03, 2017	NCR	Radiation (03CH03-KS)
Turn Table	ChamPro	EM 1000-T	060762-T	0~360 degree	NCR	Mar. 03, 2017	NCR	Radiation (03CH03-KS)
Antenna Mast	ChamPro	EM 1000-A	060762-A	1 m~4 m	NCR	Mar. 03, 2017	NCR	Radiation (03CH03-KS)

NCR: No Calibration Required



6 Uncertainty of Evaluation

Uncertainty of Radiated Emission Measurement (25 MHz ~ 1000 MHz)

Measuring Uncertainty for a Level of Confidence of 95% ($U = 2Uc(y)$)	2.8dB
---	-------

Uncertainty of Radiated Emission Measurement (1 GHz ~ 40 GHz)

Measuring Uncertainty for a Level of Confidence of 95% ($U = 2Uc(y)$)	3.3dB
---	-------



Appendix A. Test Results of Conducted Test

Conducted Output Power(Average power)

Conducted Power (*Unit: dBm)			
Band	WCDMA Band IV		
Channel	1312	1413	1513
Frequency	1712.4	1732.6	1752.6
AMR 12.2Kbps	22.89	22.85	22.85
RMC 12.2Kbps	22.91	22.86	22.88
HSDPA Subtest-1	21.79	21.82	21.81
HSDPA Subtest-2	21.78	21.88	21.86
HSDPA Subtest-3	21.37	21.39	21.38
HSDPA Subtest-4	21.34	21.40	21.36
DC-HSDPA Subtest-1	21.19	21.23	21.15
DC-HSDPA Subtest-2	21.15	21.20	21.16
DC-HSDPA Subtest-3	20.86	20.83	20.79
DC-HSDPA Subtest-4	20.79	20.83	20.82
HSUPA Subtest-1	19.78	19.86	19.78
HSUPA Subtest-2	19.79	19.83	19.82
HSUPA Subtest-3	20.83	20.88	20.82
HSUPA Subtest-4	19.26	19.34	19.27
HSUPA Subtest-5	21.80	21.80	21.80
HSPA+ (16QAM) Subtest-1	20.01	20.23	19.95



EIRP

WCDMA Band IV ($G_T - L_C = -2.40\text{dB}$)			
Channel	1312	1413	1513
	(Low)	(Mid)	(High)
Frequency	1712.4	1732.6	1752.6
(MHz)			
Conducted Power (dBm)	22.91	22.86	22.88
Conducted Power (Watts)	0.1954	0.1932	0.1941
EIRP(dBm)	20.51	20.46	20.48
EIRP(Watts)	0.1125	0.1112	0.1117



Peak-to-Average Ratio

Mode	WCDMA Band IV(dB)	Limit: 13dB
Mod.	RMC 12.2Kbps	Result
Lowest CH	2.90	PASS
Middle CH	2.93	
Highest CH	2.96	



WCDMA Band IV (RMC 12.2Kbps)

Lowest Channel

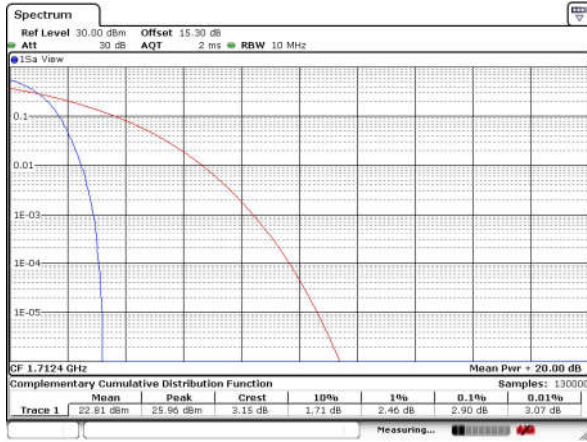

Date: 14.MAR.2017 04:42:34

Middle Channel

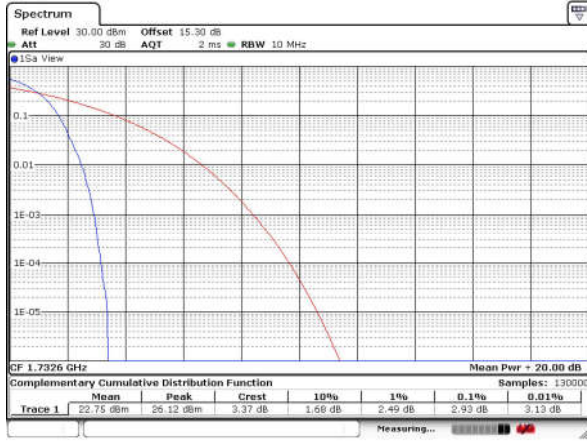

Date: 14.MAR.2017 04:42:50

Highest Channel

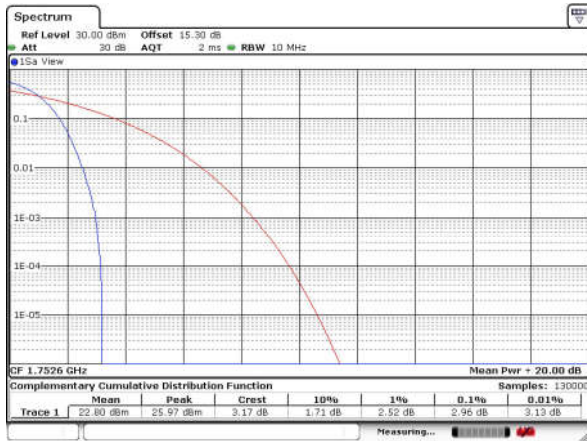

Date: 14.MAR.2017 04:43:02



26dB Bandwidth

Mode	WCDMA Band IV
Mod.	RMC 12.2Kbps
Lowest CH	4.85
Middle CH	4.86
Highest CH	4.86



WCDMA Band IV (RMC 12.2Kbps)

Lowest Channel

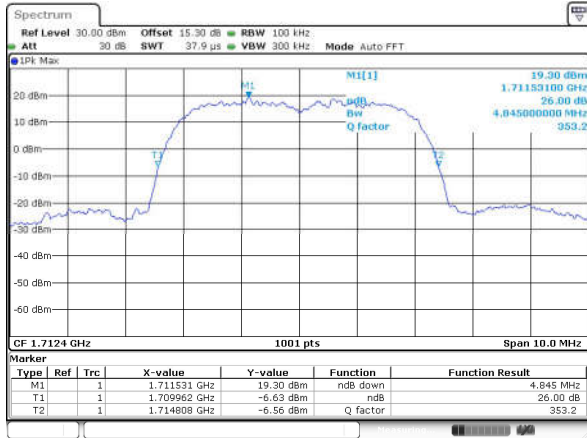

Date: 14 MAR 2017 04:40:10

Middle Channel

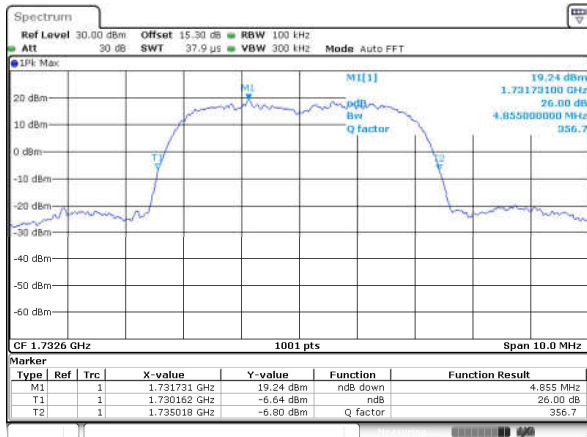

Date: 14 MAR 2017 04:40:45

Highest Channel

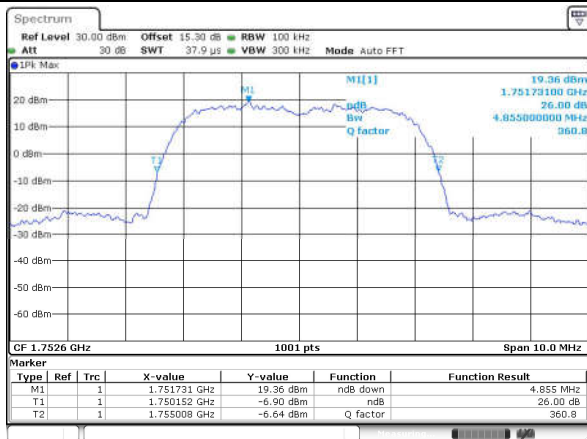

Date: 14 MAR 2017 04:41:22



Occupied Bandwidth

Mode	WCDMA Band IV
Mod.	RMC 12.2Kbps
Lowest CH	4.20
Middle CH	4.21
Highest CH	4.19



WCDMA Band IV (RMC 12.2Kbps)

Lowest Channel

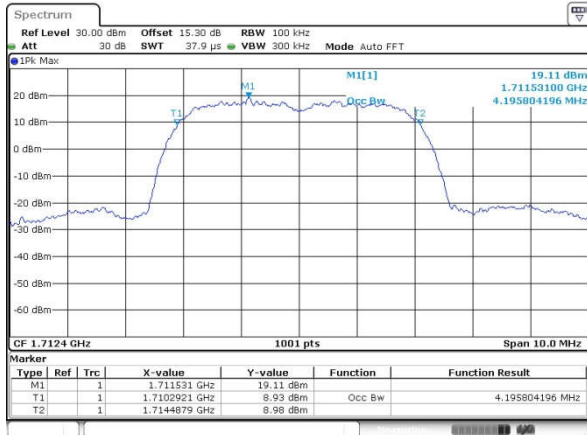

Date: 14 MAR 2017 04:56:13

Middle Channel

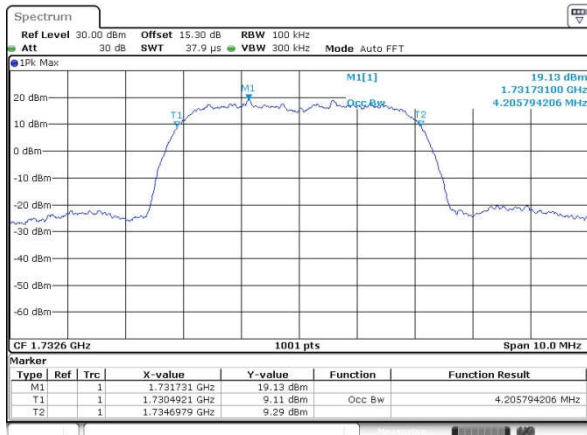

Date: 14 MAR 2017 04:56:49

Highest Channel

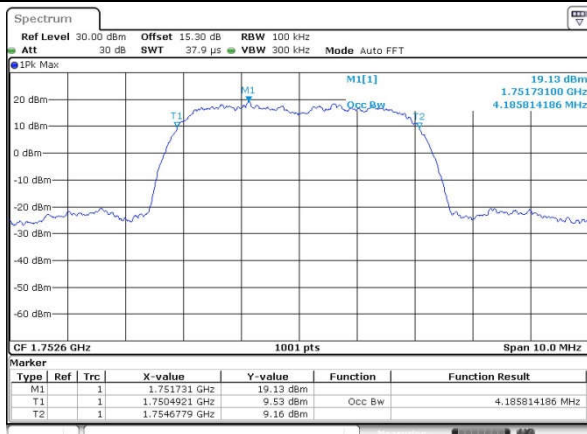

Date: 14 MAR 2017 04:57:22



Conducted Band Edge

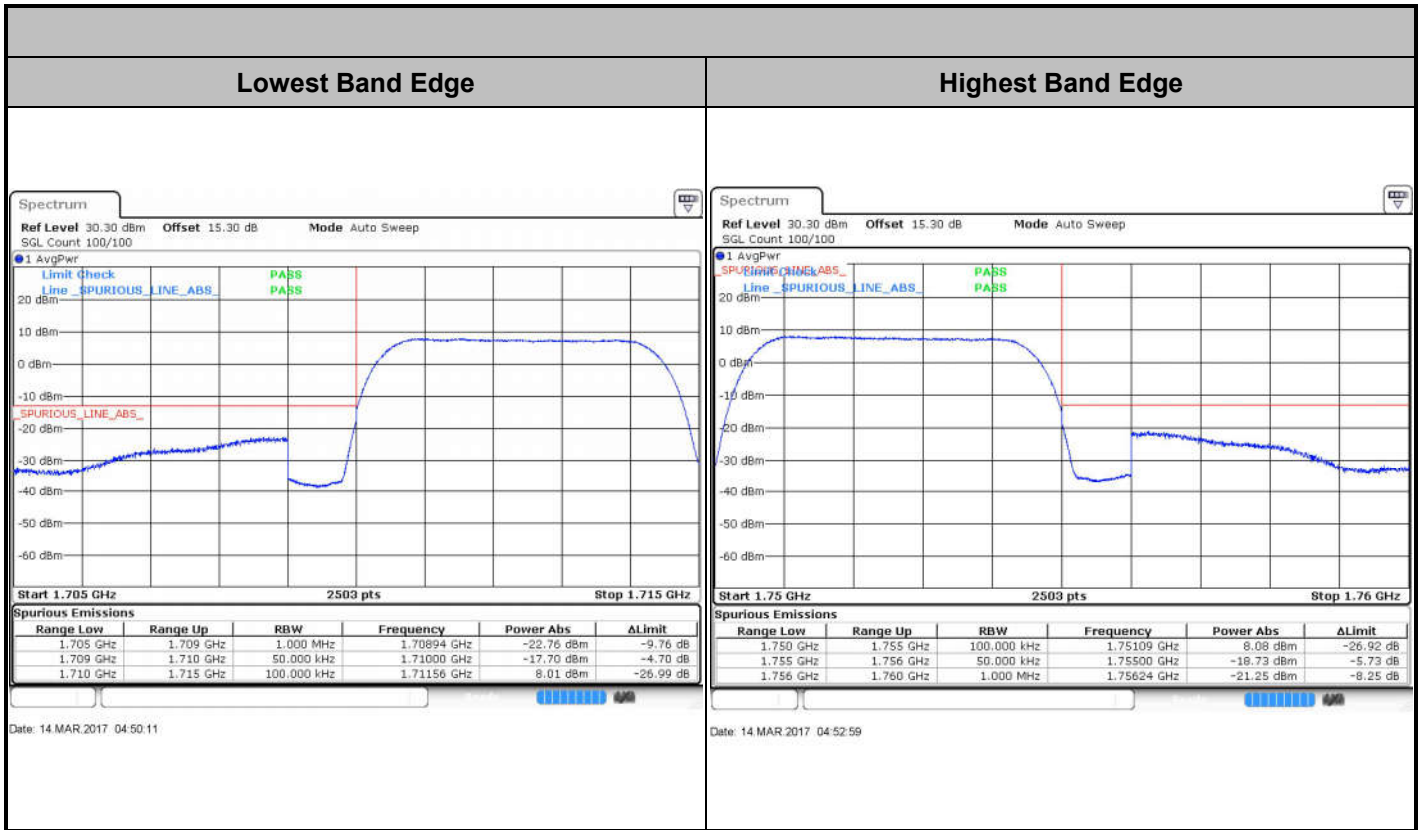



Conducted Spurious Emission

Note: Below 1MHz fail points are Spectrum Analyzer signal which can be ignored.

WCDMA Band IV (RMC 12.2Kbps)																																																	
Lowest Channel																																																	
<p>Ref Level 30.00 dBm Offset 15.30 dB Mode Auto Sweep SQL Count 10/10</p> <p>Limit Check: FAIL SPURIOUS_LINE_ABS: FAIL</p> <p>Start 9.0 kHz 50007 pts Stop 18.0 GHz</p> <table border="1"> <thead> <tr> <th>Range Low</th> <th>Range Up</th> <th>RBW</th> <th>Frequency</th> <th>Power Abs</th> <th>ΔLimit</th> </tr> </thead> <tbody> <tr><td>9.000 MHz</td><td>30.000 MHz</td><td>1.000 MHz</td><td>10.49493 MHz*</td><td>-13.53 dBm*</td><td>-26.52 dB*</td></tr> <tr><td>30.000 MHz</td><td>1.000 GHz</td><td>1.000 MHz</td><td>636.10941 MHz</td><td>-36.70 dBm</td><td>-23.70 dB</td></tr> <tr><td>1.000 GHz</td><td>1.705 GHz</td><td>1.000 MHz</td><td>1.70482 GHz</td><td>-25.75 dBm</td><td>-12.75 dB</td></tr> <tr><td>1.760 GHz</td><td>3.000 GHz</td><td>1.000 MHz</td><td>2.91143 GHz</td><td>-36.67 dBm</td><td>-23.67 dB</td></tr> <tr><td>3.000 GHz</td><td>7.000 GHz</td><td>1.000 MHz</td><td>6.91626 GHz</td><td>-31.98 dBm</td><td>-19.98 dB</td></tr> <tr><td>7.000 GHz</td><td>13.600 GHz</td><td>1.000 MHz</td><td>11.90557 GHz</td><td>-34.07 dBm</td><td>-21.07 dB</td></tr> <tr><td>13.600 GHz</td><td>18.000 GHz</td><td>1.000 MHz</td><td>16.87259 GHz</td><td>-31.87 dBm</td><td>-19.87 dB</td></tr> </tbody> </table> <p>Date: 14 MAR 2017 04:58:28</p>	Range Low	Range Up	RBW	Frequency	Power Abs	ΔLimit	9.000 MHz	30.000 MHz	1.000 MHz	10.49493 MHz*	-13.53 dBm*	-26.52 dB*	30.000 MHz	1.000 GHz	1.000 MHz	636.10941 MHz	-36.70 dBm	-23.70 dB	1.000 GHz	1.705 GHz	1.000 MHz	1.70482 GHz	-25.75 dBm	-12.75 dB	1.760 GHz	3.000 GHz	1.000 MHz	2.91143 GHz	-36.67 dBm	-23.67 dB	3.000 GHz	7.000 GHz	1.000 MHz	6.91626 GHz	-31.98 dBm	-19.98 dB	7.000 GHz	13.600 GHz	1.000 MHz	11.90557 GHz	-34.07 dBm	-21.07 dB	13.600 GHz	18.000 GHz	1.000 MHz	16.87259 GHz	-31.87 dBm	-19.87 dB	
Range Low	Range Up	RBW	Frequency	Power Abs	ΔLimit																																												
9.000 MHz	30.000 MHz	1.000 MHz	10.49493 MHz*	-13.53 dBm*	-26.52 dB*																																												
30.000 MHz	1.000 GHz	1.000 MHz	636.10941 MHz	-36.70 dBm	-23.70 dB																																												
1.000 GHz	1.705 GHz	1.000 MHz	1.70482 GHz	-25.75 dBm	-12.75 dB																																												
1.760 GHz	3.000 GHz	1.000 MHz	2.91143 GHz	-36.67 dBm	-23.67 dB																																												
3.000 GHz	7.000 GHz	1.000 MHz	6.91626 GHz	-31.98 dBm	-19.98 dB																																												
7.000 GHz	13.600 GHz	1.000 MHz	11.90557 GHz	-34.07 dBm	-21.07 dB																																												
13.600 GHz	18.000 GHz	1.000 MHz	16.87259 GHz	-31.87 dBm	-19.87 dB																																												
Middle Channel																																																	
<p>Ref Level 30.00 dBm Offset 15.30 dB Mode Auto Sweep SQL Count 10/10</p> <p>Limit Check: FAIL SPURIOUS_LINE_ABS: FAIL</p> <p>Start 9.0 kHz 50007 pts Stop 18.0 GHz</p> <table border="1"> <thead> <tr> <th>Range Low</th> <th>Range Up</th> <th>RBW</th> <th>Frequency</th> <th>Power Abs</th> <th>ΔLimit</th> </tr> </thead> <tbody> <tr><td>9.000 MHz</td><td>30.000 MHz</td><td>1.000 MHz</td><td>76.44603 MHz*</td><td>11.29 dBm*</td><td>24.29 dB*</td></tr> <tr><td>30.000 MHz</td><td>1.000 GHz</td><td>1.000 MHz</td><td>976.49926 MHz</td><td>-35.90 dBm</td><td>-22.90 dB</td></tr> <tr><td>1.000 GHz</td><td>1.705 GHz</td><td>1.000 MHz</td><td>1.28415 GHz</td><td>-37.94 dBm</td><td>-24.94 dB</td></tr> <tr><td>1.760 GHz</td><td>3.000 GHz</td><td>1.000 MHz</td><td>2.89265 GHz</td><td>-36.08 dBm</td><td>-23.08 dB</td></tr> <tr><td>3.000 GHz</td><td>7.000 GHz</td><td>1.000 MHz</td><td>6.60280 GHz</td><td>-31.85 dBm</td><td>-19.85 dB</td></tr> <tr><td>7.000 GHz</td><td>13.600 GHz</td><td>1.000 MHz</td><td>13.53047 GHz</td><td>-34.29 dBm</td><td>-21.29 dB</td></tr> <tr><td>13.600 GHz</td><td>18.000 GHz</td><td>1.000 MHz</td><td>16.56303 GHz</td><td>-31.85 dBm</td><td>-19.85 dB</td></tr> </tbody> </table> <p>Date: 14 MAR 2017 04:45:58</p>	Range Low	Range Up	RBW	Frequency	Power Abs	ΔLimit	9.000 MHz	30.000 MHz	1.000 MHz	76.44603 MHz*	11.29 dBm*	24.29 dB*	30.000 MHz	1.000 GHz	1.000 MHz	976.49926 MHz	-35.90 dBm	-22.90 dB	1.000 GHz	1.705 GHz	1.000 MHz	1.28415 GHz	-37.94 dBm	-24.94 dB	1.760 GHz	3.000 GHz	1.000 MHz	2.89265 GHz	-36.08 dBm	-23.08 dB	3.000 GHz	7.000 GHz	1.000 MHz	6.60280 GHz	-31.85 dBm	-19.85 dB	7.000 GHz	13.600 GHz	1.000 MHz	13.53047 GHz	-34.29 dBm	-21.29 dB	13.600 GHz	18.000 GHz	1.000 MHz	16.56303 GHz	-31.85 dBm	-19.85 dB	
Range Low	Range Up	RBW	Frequency	Power Abs	ΔLimit																																												
9.000 MHz	30.000 MHz	1.000 MHz	76.44603 MHz*	11.29 dBm*	24.29 dB*																																												
30.000 MHz	1.000 GHz	1.000 MHz	976.49926 MHz	-35.90 dBm	-22.90 dB																																												
1.000 GHz	1.705 GHz	1.000 MHz	1.28415 GHz	-37.94 dBm	-24.94 dB																																												
1.760 GHz	3.000 GHz	1.000 MHz	2.89265 GHz	-36.08 dBm	-23.08 dB																																												
3.000 GHz	7.000 GHz	1.000 MHz	6.60280 GHz	-31.85 dBm	-19.85 dB																																												
7.000 GHz	13.600 GHz	1.000 MHz	13.53047 GHz	-34.29 dBm	-21.29 dB																																												
13.600 GHz	18.000 GHz	1.000 MHz	16.56303 GHz	-31.85 dBm	-19.85 dB																																												
Highest Channel																																																	
<p>Ref Level 30.00 dBm Offset 15.30 dB Mode Auto Sweep SQL Count 10/10</p> <p>Limit Check: FAIL SPURIOUS_LINE_ABS: FAIL</p> <p>Start 9.0 kHz 50007 pts Stop 18.0 GHz</p> <table border="1"> <thead> <tr> <th>Range Low</th> <th>Range Up</th> <th>RBW</th> <th>Frequency</th> <th>Power Abs</th> <th>ΔLimit</th> </tr> </thead> <tbody> <tr><td>9.000 MHz</td><td>30.000 MHz</td><td>1.000 MHz</td><td>48.47003 MHz*</td><td>11.32 dBm*</td><td>24.32 dB*</td></tr> <tr><td>30.000 MHz</td><td>1.000 GHz</td><td>1.000 MHz</td><td>460.70715 MHz</td><td>-36.72 dBm</td><td>-23.72 dB</td></tr> <tr><td>1.000 GHz</td><td>1.705 GHz</td><td>1.000 MHz</td><td>1.45961 GHz</td><td>-37.02 dBm</td><td>-24.02 dB</td></tr> <tr><td>1.760 GHz</td><td>3.000 GHz</td><td>1.000 MHz</td><td>1.76008 GHz</td><td>-26.95 dBm</td><td>-13.95 dB</td></tr> <tr><td>3.000 GHz</td><td>7.000 GHz</td><td>1.000 MHz</td><td>6.71829 GHz</td><td>-32.12 dBm</td><td>-19.12 dB</td></tr> <tr><td>7.000 GHz</td><td>13.600 GHz</td><td>1.000 MHz</td><td>10.54230 GHz</td><td>-34.65 dBm</td><td>-21.65 dB</td></tr> <tr><td>13.600 GHz</td><td>18.000 GHz</td><td>1.000 MHz</td><td>15.13785 GHz</td><td>-32.24 dBm</td><td>-19.24 dB</td></tr> </tbody> </table> <p>Date: 14 MAR 2017 04:47:18</p>	Range Low	Range Up	RBW	Frequency	Power Abs	ΔLimit	9.000 MHz	30.000 MHz	1.000 MHz	48.47003 MHz*	11.32 dBm*	24.32 dB*	30.000 MHz	1.000 GHz	1.000 MHz	460.70715 MHz	-36.72 dBm	-23.72 dB	1.000 GHz	1.705 GHz	1.000 MHz	1.45961 GHz	-37.02 dBm	-24.02 dB	1.760 GHz	3.000 GHz	1.000 MHz	1.76008 GHz	-26.95 dBm	-13.95 dB	3.000 GHz	7.000 GHz	1.000 MHz	6.71829 GHz	-32.12 dBm	-19.12 dB	7.000 GHz	13.600 GHz	1.000 MHz	10.54230 GHz	-34.65 dBm	-21.65 dB	13.600 GHz	18.000 GHz	1.000 MHz	15.13785 GHz	-32.24 dBm	-19.24 dB	
Range Low	Range Up	RBW	Frequency	Power Abs	ΔLimit																																												
9.000 MHz	30.000 MHz	1.000 MHz	48.47003 MHz*	11.32 dBm*	24.32 dB*																																												
30.000 MHz	1.000 GHz	1.000 MHz	460.70715 MHz	-36.72 dBm	-23.72 dB																																												
1.000 GHz	1.705 GHz	1.000 MHz	1.45961 GHz	-37.02 dBm	-24.02 dB																																												
1.760 GHz	3.000 GHz	1.000 MHz	1.76008 GHz	-26.95 dBm	-13.95 dB																																												
3.000 GHz	7.000 GHz	1.000 MHz	6.71829 GHz	-32.12 dBm	-19.12 dB																																												
7.000 GHz	13.600 GHz	1.000 MHz	10.54230 GHz	-34.65 dBm	-21.65 dB																																												
13.600 GHz	18.000 GHz	1.000 MHz	15.13785 GHz	-32.24 dBm	-19.24 dB																																												



Frequency Stability

Test Conditions	Middle Channel	WCDMA Band IV (RMC 12.2Kbps)	Limit Note 2.
Temperature (°C)	Voltage (Volt)	Deviation (ppm)	Result
50	Normal Voltage	0.0202	PASS
40	Normal Voltage	0.0006	
30	Normal Voltage	0.0156	
20(Ref.)	Normal Voltage	0.0000	
10	Normal Voltage	0.0035	
0	Normal Voltage	0.0196	
-10	Normal Voltage	0.0012	
-20	Normal Voltage	0.0133	
-30	Normal Voltage	0.0017	
20	Maximum Voltage	0.0144	
20	Normal Voltage	0.0006	
20	Battery End Point	0.0127	

Note:

1. Normal Voltage = 3.82V. ; Battery End Point (BEP) = 3.65 V. ; Maximum Voltage =4.4V
2. The frequency fundamental emissions stay within the authorized frequency block based on the frequency deviation measured is small.



Appendix B. Test Results of Radiated Test

Radiated Spurious Emission

WCDMA Band IV (RMC 12.2Kbps)									
Channel	Frequency (MHz)	EIRP (dBm)	Limit (dBm)	Over Limit (dB)	SPA Reading (dBm)	S.G. Power (dBm)	TX Cable loss (dB)	TX Antenna Gain (dBi)	Polarization (H/V)
Middle	3465	-60.43	-13	-47.43	-67.22	-65.32	1.81	6.70	H
	5197.8	-60.12	-13	-47.12	-72.80	-67.02	2.23	9.13	H
	6930	-59.39	-13	-46.39	-74.57	-67.45	2.60	10.66	H
	3462	-59.51	-13	-46.51	-64.71	-64.40	1.81	6.70	V
	5197.8	-59.05	-13	-46.05	-72.6	-65.95	2.23	9.13	V
	6930	-59.44	-13	-46.44	-74.49	-67.50	2.6	10.66	V

Remark: Spurious emissions within 30-1000MHz were found more than 20dB below limit line.



Appendix D. Reference Report

Please refer to Sporton report number FG721309A which is issued separately.