



FCC RF Test Report

APPLICANT : Motorola Mobility, LLC
EQUIPMENT : Mobile Cellular Phone
BRAND NAME : Motorola
MODEL NAME : 10721, 12822
FCC ID : IHDT56WB3
STANDARD : 47 CFR Part 2, 22(H), 24(E), 27
CLASSIFICATION : PCS Licensed Transmitter Held to Ear (PCE)

The product was received on Mar. 31, 2017 and completely tested on May 31, 2017. We, SPORTON INTERNATIONAL INC., would like to declare that the tested sample has been evaluated in accordance with the test procedures given in ANSI / TIA / EIA-603-D-2010 and the testing has shown the tested sample to be in compliance with the applicable technical standards.

The test results in this report apply exclusively to the tested model / sample. Without written approval of SPORTON INTERNATIONAL INC., the test report shall not be reproduced except in full.

Reviewed by: Joseph Lin / Supervisor

Approved by: Jones Tsai / Manager



Testing Laboratory
1190

SPORTON INTERNATIONAL INC.

No. 52, Hwa Ya 1st Rd., Hwa Ya Technology Park, Kwei-Shan District, Tao Yuan City, Taiwan, R.O.C.

SPORTON INTERNATIONAL INC.

TEL : 886-3-327-3456

FAX : 886-3-328-4978

FCC ID : IHDT56WB3

Page Number : 1 of 34

Report Issued Date : Jun. 01, 2017

Report Version : Rev. 01

Report Template No.: BU5-FGLTE Version 1.6



TABLE OF CONTENTS

REVISION HISTORY.....3
SUMMARY OF TEST RESULT4
1 GENERAL DESCRIPTION5
1.1 Applicant5
1.2 Manufacturer5
1.3 Product Feature of Equipment Under Test.....5
1.4 Product Specification of Equipment Under Test.....7
1.5 Modification of EUT7
1.6 Emission Designator8
1.7 Testing Location11
1.8 Applicable Standards.....11
2 TEST CONFIGURATION OF EQUIPMENT UNDER TEST12
2.1 Test Mode12
2.2 Connection Diagram of Test System17
2.3 Support Unit used in test configuration and system17
2.4 Measurement Results Explanation Example17
2.5 Frequency List of Low/Middle/High Channels18
3 CONDUCTED TEST ITEMS23
3.1 Measuring Instruments23
3.2 Test Setup23
3.3 Test Result of Conducted Test23
3.4 Conducted Output Power and ERP/EIRP24
3.5 Peak-to-Average Ratio25
3.6 Occupied Bandwidth26
3.7 Conducted Band Edge27
3.8 Conducted Spurious Emission29
3.9 Frequency Stability30
4 RADIATED TEST ITEMS31
4.1 Measuring Instruments31
4.2 Test Setup31
4.3 Test Result of Radiated Test31
4.4 Radiated Spurious Emission32
5 LIST OF MEASURING EQUIPMENT33
6 UNCERTAINTY OF EVALUATION34
APPENDIX A. TEST RESULTS OF CONDUCTED TEST
APPENDIX B. TEST RESULTS OF ERP/EIRP AND RADIATED TEST



SUMMARY OF TEST RESULT

Report Section	FCC Rule	Description	Limit	Result	Remark
3.4	§2.1046	Conducted Output Power	Reporting Only	PASS	-
	§27.50(b)(10) §22.913(a)(2)	Effective Radiated Power (Band 5) (Band 26)	ERP < 7 Watt		
	§27.50(c)(10)	Effective Radiated Power (Band 12) (Band 17)	ERP < 3 Watt		
	§24.232(c) §27.50(h)(2)	Equivalent Isotropic Radiated Power (Band 2) (Band 7) (Band 38) (Band 41)	EIRP < 2Watt		
	§27.50(d)(4)	Equivalent Isotropic Radiated Power (Band 4)	EIRP < 1Watt		
3.5	§24.232(d)	Peak-to-Average Ratio	<13 dB	PASS	-
3.6	§2.1049	Occupied Bandwidth	Reporting Only	PASS	-
3.7	§2.1051 §22.917(a) §24.238(a) §27.53(g) §27.53(h)	Conducted Band Edge Measurement (Band 2) (Band 4) (Band 5) (Band 12) (Band 17) (Band 26)	< 43+10log ₁₀ (P[Watts])	PASS	-
	§27.53(m)(4)	Conducted Band Edge Measurement (Band 7) (Band 38) (Band 41)	§27.53(m)(4)		
3.8	§2.1051 §22.917(a) §24.238(a) §27.53(g) §27.53(h)	Conducted Spurious Emission (Band 2) (Band 4) (Band 5) (Band 12) (Band 17) (Band 26)	< 43+10log ₁₀ (P[Watts])	PASS	-
	§2.1051 §27.53(m)(4)	Conducted Spurious Emission (Band 7) (Band 38) (Band 41)	< 55+10log ₁₀ (P[Watts])		
3.9	§2.1055 §22.355	Frequency Stability Temperature & Voltage	< 2.5 ppm for Part 22	PASS	-
	§2.1055 §24.235 §27.54		Within Authorized Band		
4.4	§2.1053 §22.917(a) §24.238(a) §27.53(g) §27.53(h)	Radiated Spurious Emission (Band 2) (Band 4) (Band 5) (Band 12) (Band 17) (Band 26)	< 43+10log ₁₀ (P[Watts])	PASS	Under limit 16.06 dB at 5298.000 MHz
	§2.1053 §27.53(m)(4)	Radiated Spurious Emission (Band 7) (Band 38) (Band 41)	< 55+10log ₁₀ (P[Watts])		



1 General Description

1.1 Applicant

Motorola Mobility, LLC

222 W Merchandise Mart Plaza, Suite 1800, Chicago, IL 60654, United States

1.2 Manufacturer

Motorola Mobility, LLC

222 W Merchandise Mart Plaza, Suite 1800, Chicago, IL 60654, United States

1.3 Product Feature of Equipment Under Test

Product Feature	
Equipment	Mobile Cellular Phone
Brand Name	Motorola
Model Name	10721, 12822
FCC ID	IHDT56WB3
IMEI Code	IMEI 1: 353312080018213 for Radiation) IMEI 2: 353312080018221
	IMEI 1: 353312080018239 for Conducted) IMEI 2: 353312080018247
EUT supports Radios application	CDMA/EV-DO/GSM/EGPRS/WCDMA/HSPA/LTE/NFC WLAN 11b/g/n HT20 WLAN 11a/n HT20/HT40 WLAN 11ac VHT20/VHT40/VHT80 Bluetooth BR/EDR/LE
HW Version	DVT2
EUT Stage	Identical Prototype

Remark: The above EUT's information was declared by manufacturer. Please refer to the specifications or user's manual for more detailed description.



Accessory List	
AC Adapter 1	Brand Name : Motorola
	Model Name : SPN5970A
AC Adapter 2	Brand Name : Motorola
	Model Name : SPN5993A
AC Adapter 3	Brand Name : Motorola
	Model Name : SPN5978A
Battery 1	Brand Name : Motorola
	Model Name : SNN5986A
Battery 2	Brand Name : Motorola
	Model Name : SNN5897A
Earphone	Brand Name : Motorola
	Model Name : SH38C16618
USB Cable	Brand Name : Motorola
	Model Name : SKN6473A
USB-C Data Cable	Brand Name : Motorola
	Model Name : SKN6474A



1.4 Product Specification of Equipment Under Test

Standards-related Product Specification	
Tx Frequency	LTE Band 2 : 1850.7 MHz ~ 1909.3 MHz LTE Band 4 : 1710.7 MHz ~ 1754.3 MHz LTE Band 5 : 824.7 MHz ~ 848.3 MHz LTE Band 7 : 2502.5 MHz ~ 2567.5 MHz LTE Band 12 : 699.7 MHz ~ 715.3 MHz LTE Band 17 : 706.5 MHz ~ 713.5 MHz LTE Band 26 : 814.7 MHz ~ 848.3 MHz LTE Band 38 : 2572.5MHz ~ 2617.5MHz LTE Band 41 : 2547.5 MHz ~ 2652.5 MHz
Rx Frequency	LTE Band 2 : 1930.7 MHz ~ 1989.3 MHz LTE Band 4 : 2110.7 MHz ~ 2154.3 MHz LTE Band 5 : 869.7 MHz ~ 893.3 MHz LTE Band 7 : 2622.5MHz ~ 2687.5 MHz LTE Band 12 : 729.7 MHz ~ 745.3 MHz LTE Band 17 : 736.5 MHz ~ 743.5 MHz LTE Band 26 : 859.7 MHz ~ 893.3 MHz LTE Band 38 : 2572.5MHz ~ 2617.5MHz LTE Band 41 : 2547.5 MHz ~ 2652.5 MHz
Bandwidth	LTE Band 2 : 1.4MHz / 3MHz / 5MHz / 10MHz / 15MHz / 20MHz LTE Band 4 : 1.4MHz / 3MHz / 5MHz / 10MHz / 15MHz / 20MHz LTE Band 5 : 1.4MHz / 3MHz / 5MHz / 10MHz LTE Band 7 : 5MHz / 10MHz / 15MHz / 20MHz LTE Band 12 : 1.4MHz / 3MHz / 5MHz / 10MHz LTE Band 17 : 5MHz / 10MHz LTE Band 26 : 1.4MHz / 3MHz / 5MHz / 10MHz / 15MHz LTE Band 38 : 5MHz / 10MHz / 15MHz / 20MHz LTE Band 41 : 5MHz / 10MHz / 15MHz / 20MHz
Maximum Output Power to Antenna	LTE Band 2 : 22.76 dBm LTE Band 4 : 22.80 dBm LTE Band 5 : 23.15 dBm LTE Band 7 : 22.89 dBm LTE Band 12 : 22.95 dBm LTE Band 17 : 22.84 dBm LTE Band 26 : 23.32 dBm LTE Band 38 : 22.86 dBm LTE Band 41 : 22.83 dBm
Antenna Type	Fixed Internal Antenna
Type of Modulation	QPSK / 16QAM / 64QAM
Remark : LTE TDD B41 in this device is not a 3GPP compliant band. Regarding LTE TDD B41, the device capability is limited in a narrower frequency range (2545MHz~2655MHz) than is specified in 3GPP 34.121. The detailed implementation is illustrated in the operational description.	

1.5 Modification of EUT

No modifications are made to the EUT during all test items.



1.6 Emission Designator

LTE Band 2		QPSK			16QAM			64QAM		
BW (MHz)	Frequency Range (MHz)	Emission Designator (99%OBW)	Frequency Tolerance (ppm)	Maximum EIRP(W)	Emission Designator (99%OBW)	Frequency Tolerance (ppm)	Maximum EIRP(W)	Emission Designator (99%OBW)	Frequency Tolerance (ppm)	Maximum EIRP(W)
1.4	1850.7 ~ 1909.3	1M09G7D	-	0.1986	1M09W7D	-	0.1675	1M09W7D	-	0.1626
3	1851.5 ~ 1908.5	2M73G7D	-	0.1928	2M73W7D	-	0.1596	2M73W7D	-	0.1589
5	1852.5 ~ 1907.5	4M51G7D	-	0.1919	4M50W7D	-	0.1629	4M48W7D	-	0.1622
10	1855.0 ~ 1905.0	9M05G7D	0.0089	0.1959	8M99W7D	-	0.1644	9M01W7D	-	0.1611
15	1857.5 ~ 1902.5	13M5G7D	-	0.1963	13M5W7D	-	0.1644	13M5W7D	-	0.1633
20	1860.0 ~ 1900.0	18M4G7D	-	0.2023	18M5W7D	-	0.1690	18M4W7D	-	0.1675
LTE Band 4		QPSK			16QAM			64QAM		
BW (MHz)	Frequency Range (MHz)	Emission Designator (99%OBW)	Frequency Tolerance (ppm)	Maximum EIRP(W)	Emission Designator (99%OBW)	Frequency Tolerance (ppm)	Maximum EIRP(W)	Emission Designator (99%OBW)	Frequency Tolerance (ppm)	Maximum EIRP(W)
1.4	1710.7 ~ 1754.3	1M09G7D	-	0.1986	1M09W7D	-	0.1675	1M09W7D	-	0.1629
3	1711.5 ~ 1753.5	2M72G7D	-	0.1986	2M73W7D	-	0.1675	2M73W7D	-	0.1626
5	1712.5 ~ 1752.5	4M50G7D	-	0.1991	4M49W7D	-	0.1683	4M51W7D	-	0.1652
10	1715.0 ~ 1750.0	9M05G7D	0.0101	0.2037	9M03W7D	-	0.1698	9M05W7D	-	0.1660
15	1717.5 ~ 1747.5	13M5G7D	-	0.1995	13M5W7D	-	0.1698	13M5W7D	-	0.1663
20	1720.0 ~ 1745.0	18M4G7D	-	0.2042	18M4W7D	-	0.1714	18M5W7D	-	0.1679
LTE Band 5		QPSK			16QAM			64QAM		
BW (MHz)	Frequency Range (MHz)	Emission Designator (99%OBW)	Frequency Tolerance (ppm)	Maximum ERP(W)	Emission Designator (99%OBW)	Frequency Tolerance (ppm)	Maximum ERP(W)	Emission Designator (99%OBW)	Frequency Tolerance (ppm)	Maximum EIRP(W)
1.4	824.7 ~ 848.3	1M09G7D	-	0.1109	1M09W7D	-	0.0912	1M09W7D	-	0.0729
3	825.5 ~ 847.5	2M72G7D	-	0.1114	2M73W7D	-	0.0914	2M73W7D	-	0.0731
5	826.5 ~ 846.5	4M51G7D	-	0.1119	4M52W7D	-	0.0923	4M51W7D	-	0.0736
10	829.0 ~ 844.0	9M03G7D	0.0075	0.1122	9M03W7D	-	0.0925	9M07W7D	-	0.0743
LTE Band 7		QPSK			16QAM			64QAM		
BW (MHz)	Frequency Range (MHz)	Emission Designator (99%OBW)	Frequency Tolerance (ppm)	Maximum EIRP(W)	Emission Designator (99%OBW)	Frequency Tolerance (ppm)	Maximum EIRP(W)	Emission Designator (99%OBW)	Frequency Tolerance (ppm)	Maximum EIRP(W)
5	2502.5 ~ 2567.5	4M51G7D	-	0.1535	4M50W7D	-	0.1297	4M49W7D	-	0.1007
10	2505.0 ~ 2565.0	9M01G7D	0.0078	0.1545	9M05W7D	-	0.1306	9M05W7D	-	0.1014
15	2507.5 ~ 2562.5	13M5G7D	-	0.1567	13M4W7D	-	0.1330	13M5W7D	-	0.1047
20	2510.0 ~ 2560.0	18M4G7D	-	0.1581	18M4W7D	-	0.1327	18M3W7D	-	0.1045



LTE Band 12		QPSK			16QAM			64QAM		
BW (MHz)	Frequency Range (MHz)	Emission Designator (99%OBW)	Frequency Tolerance (ppm)	Maximum ERP(W)	Emission Designator (99%OBW)	Frequency Tolerance (ppm)	Maximum ERP(W)	Emission Designator (99%OBW)	Frequency Tolerance (ppm)	Maximum EIRP(W)
1.4	699.7 ~ 715.3	1M09G7D	-	0.1067	1M10W7D	-	0.0895	1M09W7D	-	0.0693
3	700.5 ~ 714.5	2M73G7D	-	0.1042	2M73W7D	-	0.0877	2M71W7D	-	0.0695
5	701.5 ~ 713.5	4M51G7D	-	0.1054	4M51W7D	-	0.0910	4M49W7D	-	0.0705
10	704.0 ~ 711.0	9M05G7D	0.0105	0.1072	9M01W7D	-	0.0887	9M03W7D	-	0.0708
LTE Band 17		QPSK			16QAM			64QAM		
BW (MHz)	Frequency Range (MHz)	Emission Designator (99%OBW)	Frequency Tolerance (ppm)	Maximum ERP(W)	Emission Designator (99%OBW)	Frequency Tolerance (ppm)	Maximum ERP(W)	Emission Designator (99%OBW)	Frequency Tolerance (ppm)	Maximum EIRP(W)
5	706.5 ~ 713.5	4M49G7D	-	0.1042	4M50W7D	-	0.0877	4M51W7D	-	0.0697
10	709.0 ~ 711.0	9M05G7D	0.0096	0.1045	9M01W7D	-	0.0871	8M99W7D	-	0.0695
LTE Band 26		QPSK			16QAM			64QAM		
BW (MHz)	Frequency Range (MHz)	Emission Designator (99%OBW)	Frequency Tolerance (ppm)	Maximum EIRP(W)	Emission Designator (99%OBW)	Frequency Tolerance (ppm)	Maximum EIRP(W)	Emission Designator (99%OBW)	Frequency Tolerance (ppm)	Maximum EIRP(W)
1.4	824.7 ~ 848.3	1M10G7D	-	0.1164	1M10W7D	-	0.0966	1M09W7D	-	0.0748
3	825.5 ~ 847.5	2M73G7D	-	0.1159	2M73W7D	-	0.0968	2M72W7D	-	0.0733
5	826.5 ~ 846.5	4M49G7D	-	0.1140	4M51W7D	-	0.0971	4M49W7D	-	0.0750
10	829.0 ~ 844.0	9M09G7D	0.0090	0.1132	9M01W7D	-	0.0946	9M03W7D	-	0.0753
15	831.5 ~ 841.5	13M5G7D	-	0.1167	13M5W7D	-	0.0955	13M5W7D	-	0.0759
LTE Band 38		QPSK			16QAM			64QAM		
BW (MHz)	Frequency Range (MHz)	Emission Designator (99%OBW)	Frequency Tolerance (ppm)	Maximum EIRP(W)	Emission Designator (99%OBW)	Frequency Tolerance (ppm)	Maximum EIRP(W)	Emission Designator (99%OBW)	Frequency Tolerance (ppm)	Maximum EIRP(W)
5	2572.5 ~ 2617.5	4M50G7D	-	0.1531	4M50W7D	-	0.1236	4M50W7D	-	0.1002
10	2575.0 ~ 2615.0	9M03G7D	0.0099	0.1535	9M03W7D	-	0.1247	9M01W7D	-	0.0993
15	2577.5 ~ 2612.5	13M4G7D	-	0.1567	13M5W7D	-	0.1259	13M4W7D	-	0.0989
20	2580.0 ~ 2610.0	18M4G7D	-	0.1570	18M4W7D	-	0.1259	18M3W7D	-	0.1000
LTE Band 41		QPSK			16QAM			64QAM		
BW (MHz)	Frequency Range (MHz)	Emission Designator (99%OBW)	Frequency Tolerance (ppm)	Maximum EIRP(W)	Emission Designator (99%OBW)	Frequency Tolerance (ppm)	Maximum EIRP(W)	Emission Designator (99%OBW)	Frequency Tolerance (ppm)	Maximum EIRP(W)
5	2547.5 ~ 2652.5	4M48G7D	-	0.1507	4M51W7D	-	0.1213	4M50W7D	-	0.0920
10	2550.0 ~ 2650.0	9M09G7D	0.0095	0.1517	9M05W7D	-	0.1236	9M03W7D	-	0.0918
15	2552.5 ~ 2647.5	13M5G7D	-	0.1531	13M5W7D	-	0.1242	13M5W7D	-	0.0935
20	2555.0 ~ 2645.0	18M3G7D	-	0.1560	18M4W7D	-	0.1250	18M4W7D	-	0.0929



LTE Band 38_CA			QPSK		16QAM		64QAM	
CA Combination BW (MHz) PCC/SCC	Primary Component Carrier Frequency Range (MHz)	Secondary Component Carrier Frequency Range (MHz)	Emission Designator (99%OBW)	Maximum EIRP(W)	Emission Designator (99%OBW)	Maximum EIRP(W)	Emission Designator (99%OBW)	Maximum EIRP(W)
15 + 15	2577.5 ~ 2597.5	2592.5 ~ 2612.5	28M8G7D	0.2028	29M0W7D	0.1611	28M7W7D	0.0979
20 + 20	2580.0 ~ 2590.2	2599.8 ~ 2610.0	38M0G7D	0.1928	37M6W7D	0.1687	37M6W7D	0.1288
LTE Band 41_CA			QPSK		16QAM		64QAM	
CA Combination BW (MHz) PCC/SCC	Primary Component Carrier Frequency Range (MHz)	Secondary Component Carrier Frequency Range (MHz)	Emission Designator (99%OBW)	Maximum EIRP(W)	Emission Designator (99%OBW)	Maximum EIRP(W)	Emission Designator (99%OBW)	Maximum EIRP(W)
5 + 20	2547.5 ~ 2633.3	2559.2 ~ 2645.0	23M3G7D	0.2065	23M2W7D	0.1589	23M4W7D	0.0935
20 + 5	2555.0 ~ 2640.8	2566.7 ~ 2652.5	23M3G7D	0.1832	23M6W7D	0.1483	23M5W7D	0.0873
10 + 20	2550.0 ~ 2630.6	2564.4 ~ 2645.0	28M0G7D	0.1871	28M2W7D	0.1462	28M3W7D	0.0861
20 + 10	2555.0 ~ 2635.6	2569.4 ~ 2650.0	28M1G7D	0.1995	28M1W7D	0.1581	28M1W7D	0.0920
15 + 15	2552.5 ~ 2632.5	2567.5 ~ 2647.5	28M7G7D	0.1841	28M6W7D	0.1496	28M6W7D	0.0824
20 + 15	2555.0 ~ 2630.4	2572.1 ~ 2647.5	33M9G7D	0.1968	33M0W7D	0.1531	33M5W7D	0.0893
15 + 20	2552.5 ~ 2627.9	2567.5 ~ 2645.0	32M7G7D	0.2065	32M7W7D	0.1652	32M9W7D	0.0944
20 + 20	2555.0 ~ 2625.2	2574.8 ~ 2645.0	37M7G7D	0.2000	37M7W7D	0.1578	38M0W7D	0.1062



1.7 Testing Location

Sporton Lab is accredited to ISO 17025 by Taiwan Accreditation Foundation (TAF code : 1190) and the FCC designation No. TW1190 under the FCC 2.948(e) by Mutual Recognition Agreement (MRA) in FCC Test.

Test Site	SPORTON INTERNATIONAL INC.
Test Site Location	No. 52, Hwa Ya 1 st Rd., Hwa Ya Technology Park, Kwei-Shan District, Tao Yuan City, Taiwan, R.O.C. TEL: +886-3-327-3456 FAX: +886-3-328-4978
Test Site No.	Sporton Site No.
	TH05-HY; 03CH07-HY

1.8 Applicable Standards

According to the specifications of the manufacturer, the EUT must comply with the requirements of the following standards:

- ♦ 47 CFR Part 2, 22(H), 24(E), 27
- ♦ ANSI / TIA / EIA-603-D-2010
- ♦ FCC KDB 971168 D01 Power Meas. License Digital Systems v02r02
- ♦ FCC KDB 412172 D01 Determining ERP and EIRP v01r01

Remark:

1. All test items were verified and recorded according to the standards and without any deviation during the test.
2. This EUT has also been tested and complied with the requirements of FCC Part 15, Subpart B, recorded in a separate test report.



2 Test Configuration of Equipment Under Test

2.1 Test Mode

Antenna port conducted and radiated test items listed below are performed according to KDB 971168 D01 Power Meas. License Digital Systems v02r02 with maximum output power.

Radiated measurements are performed by rotating the EUT in three different orthogonal test planes to find the maximum emission.

Test Items	Band	Bandwidth (MHz)						Modulation			RB #			Test Channel		
		1.4	3	5	10	15	20	QPSK	16QAM	64QAM	1	Half	Full	L	M	H
Max. Output Power	2	Y	Y	Y	Y	Y	Y	Y	Y	Y	Y	Y	Y	Y	Y	Y
	4	Y	Y	Y	Y	Y	Y	Y	Y	Y	Y	Y	Y	Y	Y	Y
	5	Y	Y	Y	Y	-	-	Y	Y	Y	Y	Y	Y	Y	Y	Y
	7	-	-	Y	Y	Y	Y	Y	Y	Y	Y	Y	Y	Y	Y	Y
	12	Y	Y	Y	Y	-	-	Y	Y	Y	Y	Y	Y	Y	Y	Y
	17	-	-	Y	Y	-	-	Y	Y	Y	Y	Y	Y	Y	Y	Y
	26	Y	Y	Y	Y	Y	-	Y	Y	Y	Y	Y	Y	Y	Y	Y
	38	-	-	Y	Y	Y	Y	Y	Y	Y	Y	Y	Y	Y	Y	Y
	41	-	-	Y	Y	Y	Y	Y	Y	Y	Y	Y	Y	Y	Y	Y
Peak-to-Average Ratio	2						Y	Y	Y	Y	Y		Y	Y	Y	Y
	4						Y	Y	Y	Y	Y		Y	Y	Y	Y
	5				Y	-	-	Y	Y	Y	Y		Y	Y	Y	Y
	7	-	-				Y	Y	Y	Y	Y		Y	Y	Y	Y
	12				Y	-	-	Y	Y	Y	Y		Y	Y	Y	Y
	17	-	-		Y	-	-	Y	Y	Y	Y		Y	Y	Y	Y
	26					Y	-	Y	Y	Y	Y		Y	Y	Y	Y
	38	-	-				Y	Y	Y	Y	Y		Y	Y	Y	Y
	41	-	-				Y	Y	Y	Y	Y		Y	Y	Y	Y



Test Items	Band	Bandwidth (MHz)						Modulation			RB #			Test Channel		
		1.4	3	5	10	15	20	QPSK	16QAM	64QAM	1	Half	Full	L	M	H
26dB and 99% Bandwidth	2	✓	✓	✓	✓	✓	✓	✓	✓	✓			✓	✓	✓	✓
	4	✓	✓	✓	✓	✓	✓	✓	✓	✓			✓	✓	✓	✓
	5	✓	✓	✓	✓	-	-	✓	✓	✓			✓	✓	✓	✓
	7	-	-	✓	✓	✓	✓	✓	✓	✓			✓	✓	✓	✓
	12	✓	✓	✓	✓	-	-	✓	✓	✓			✓	✓	✓	✓
	17	-	-	✓	✓	-	-	✓	✓	✓			✓	✓	✓	✓
	26	✓	✓	✓	✓	✓	-	✓	✓	✓			✓	✓	✓	✓
	38	-	-	✓	✓	✓	✓	✓	✓	✓			✓	✓	✓	✓
	41	-	-	✓	✓	✓	✓	✓	✓	✓			✓	✓	✓	✓
Conducted Band Edge	2	✓	✓	✓	✓	✓	✓	✓	✓	✓	✓		✓	✓		✓
	4	✓	✓	✓	✓	✓	✓	✓	✓	✓	✓		✓	✓		✓
	5	✓	✓	✓	✓	-	-	✓	✓	✓	✓		✓	✓		✓
	7	-	-	✓	✓	✓	✓	✓	✓	✓	✓		✓	✓		✓
	12	✓	✓	✓	✓	-	-	✓	✓	✓	✓		✓	✓		✓
	17	-	-	✓	✓	-	-	✓	✓	✓	✓		✓	✓		✓
	26	✓	✓	✓	✓	✓	-	✓	✓	✓	✓		✓	✓		✓
	38	-	-	✓	✓	✓	✓	✓	✓	✓	✓		✓	✓		✓
	41	-	-	✓	✓	✓	✓	✓	✓	✓	✓		✓	✓		✓
Conducted Spurious Emission	2	✓	✓	✓	✓	✓	✓	✓	✓	✓	✓			✓	✓	✓
	4	✓	✓	✓	✓	✓	✓	✓	✓	✓	✓			✓	✓	✓
	5	✓	✓	✓	✓	-	-	✓	✓	✓	✓			✓	✓	✓
	7	-	-	✓	✓	✓	✓	✓	✓	✓	✓			✓	✓	✓
	12	✓	✓	✓	✓	-	-	✓	✓	✓	✓			✓	✓	✓
	17	-	-	✓	✓	-	-	✓	✓	✓	✓			✓	✓	✓
	26	✓	✓	✓	✓	✓	-	✓	✓	✓	✓			✓	✓	✓
	38	-	-	✓	✓	✓	✓	✓	✓	✓	✓			✓	✓	✓
	41	-	-	✓	✓	✓	✓	✓	✓	✓	✓			✓	✓	✓



Test Items	Band	Bandwidth (MHz)						Modulation			RB #			Test Channel			
		1.4	3	5	10	15	20	QPSK	16QAM	64QAM	1	Half	Full	L	M	H	
Frequency Stability	2				v			v						v		v	
	4				v			v						v		v	
	5				v	-	-	v						v		v	
	7	-	-		v			v						v		v	
	12				v	-	-	v						v		v	
	17	-	-		v	-	-	v						v		v	
	26				v		-	v						v		v	
	38	-	-		v			v						v		v	
	41	-	-		v			v						v		v	
E.R.P./ E.I.R.P.	2	v	v	v	v	v	v	v	v	v	v	v			v	v	v
	4	v	v	v	v	v	v	v	v	v	v	v			v	v	v
	5	v	v	v	v	-	-	v	v	v	v	v			v	v	v
	7	-	-	v	v	v	v	v	v	v	v	v			v	v	v
	12	v	v	v	v	v	v	v	v	v	v	v			v	v	v
	17	-	-	v	v	-	-	v	v	v	v	v			v	v	v
	26	v	v	v	v	v	-	v	v	v	v	v			v	v	v
	38	-	-	v	v	v	v	v	v	v	v	v			v	v	v
	41	-	-	v	v	v	v	v	v	v	v	v			v	v	v



Test Items	Band	Bandwidth (MHz)						Modulation			RB #			Test Channel		
		1.4	3	5	10	15	20	QPSK	16QAM	64QAM	1	Half	Full	L	M	H
Radiated Spurious Emission	2	√	√	√	√	√	√	√			√			√	√	√
	4	√	√	√	√	√	√	√			√			√	√	√
	5	√	√	√	√	-	-	√			√			√	√	√
	7	-	-	√	√	√	√	√			√			√	√	√
	12	√	√	√	√	-	-	√			√			√	√	√
	17	-	-	√	√	-	-	√			√			√	√	√
	26	√	√	√	√	√	-	√			√			√	√	√
	38	-	-	√	√	√	√	√						√	√	√
	41	-	-	√	√	√	√	√			√			√	√	√
Note	<ol style="list-style-type: none"> The mark "√" means that this configuration is chosen for testing The mark "-" means that this bandwidth is not supported. The device is investigated from 30MHz to 10 times of fundamental signal for radiated spurious emission test under different RB size/offset and modulations in exploratory test. Subsequently, only the worst case emissions are reported. All the radiated test cases were performance with Adapter 1 and Battery 2. 															



Test Items	Band	Bandwidth (MHz)								Modulation			RB #			Test Channel		
		20+20	20+15	15+20	20+10	10+20	20+5	5+20	15+15	QPSK	16QAM	64QAM	1	Half	Full	L	M	H
Max. Output Power	38_CA	√							√	√	√	√	√	√	√	√	√	√
	41_CA	√	√	√	√	√	√	√	√	√	√	√	√	√	√	√	√	√
26dB and 99% Bandwidth	38_CA	√							√	√	√	√			√	√	√	√
	41_CA	√	√	√	√	√	√	√	√	√	√	√			√	√	√	√
Conducted Band Edge	38_CA	√							√	√	√	√	√		√	√		√
	41_CA	√	√	√	√	√	√	√	√	√	√	√	√		√	√		√
Conducted Spurious Emission	38_CA	√							√	√	√	√	√			√	√	√
	41_CA	√	√	√	√	√	√	√	√	√	√	√	√			√	√	√
E.I.R.P.	38_CA	√							√	√	√	√	√			√	√	√
	41_CA	√	√	√	√	√	√	√	√	√	√	√	√			√	√	√
Radiated Spurious Emission	38_CA	√							√	√			√			√	√	√
	41_CA	√	√	√	√	√	√	√	√	√			√			√	√	√
Note	<ol style="list-style-type: none"> The mark “√ “ means that this configuration is chosen for testing The mark “-“ means that this bandwidth is not supported. The device is investigated from 30MHz to 10 times of fundamental signal for radiated spurious emission test under different RB size/offset and modulations in exploratory test. Subsequently, only the worst case emissions are reported. All the radiated test cases were performance with Adapter 1 and Battery 2. 																	

2.2 Connection Diagram of Test System

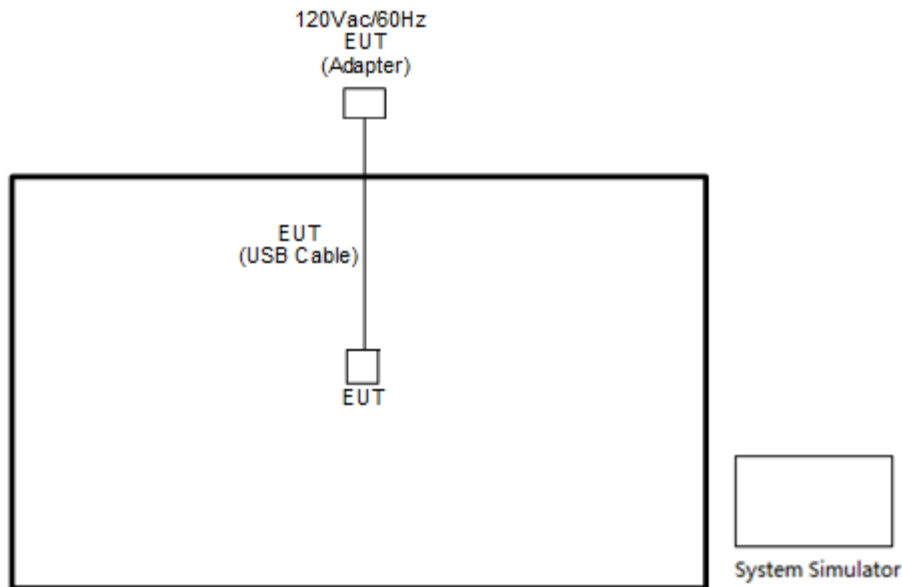

2.3 Support Unit used in test configuration and system

Item	Equipment	Trade Name	Model No.	FCC ID	Data Cable	Power Cord
1.	LTE Base Station	Anritsu	MT8820C	N/A	N/A	Unshielded, 1.8 m

2.4 Measurement Results Explanation Example

For all conducted test items:

The offset level is set in the spectrum analyzer to compensate the RF cable loss and attenuator factor between EUT conducted output port and spectrum analyzer. With the offset compensation, the spectrum analyzer reading level is exactly the EUT RF output level.

The spectrum analyzer offset is derived from RF cable loss and attenuator factor.

Offset = RF cable loss + attenuator factor.

Following shows an offset computation example with cable loss 4.2 dB and 10dB attenuator.

Example :

$$\begin{aligned} \text{Offset(dB)} &= \text{RF cable loss(dB)} + \text{attenuator factor(dB)}. \\ &= 4.2 + 10 = 14.2 \text{ (dB)} \end{aligned}$$



2.5 Frequency List of Low/Middle/High Channels

LTE Band 2 Channel and Frequency List				
BW [MHz]	Channel/Frequency(MHz)	Lowest	Middle	Highest
20	Channel	18700	18900	19100
	Frequency	1860	1880	1900
15	Channel	18675	18900	19125
	Frequency	1857.5	1880	1902.5
10	Channel	18650	18900	19150
	Frequency	1855	1880	1905
5	Channel	18625	18900	19175
	Frequency	1852.5	1880	1907.5
3	Channel	18615	18900	19185
	Frequency	1851.5	1880	1908.5
1.4	Channel	18607	18900	19193
	Frequency	1850.7	1880	1909.3

LTE Band 4 Channel and Frequency List				
BW [MHz]	Channel/Frequency(MHz)	Lowest	Middle	Highest
20	Channel	20050	20175	20300
	Frequency	1720	1732.5	1745
15	Channel	20025	20175	20325
	Frequency	1717.5	1732.5	1747.5
10	Channel	20000	20175	20350
	Frequency	1715	1732.5	1750
5	Channel	19975	20175	20375
	Frequency	1712.5	1732.5	1752.5
3	Channel	19965	20175	20385
	Frequency	1711.5	1732.5	1753.5
1.4	Channel	19957	20175	20393
	Frequency	1710.7	1732.5	1754.3



LTE Band 5 Channel and Frequency List				
BW [MHz]	Channel/Frequency(MHz)	Lowest	Middle	Highest
10	Channel	20450	20525	20600
	Frequency	829	836.5	844
5	Channel	20425	20525	20625
	Frequency	826.5	836.5	846.5
3	Channel	20415	20525	20635
	Frequency	825.5	836.5	847.5
1.4	Channel	20407	20525	20643
	Frequency	824.7	836.5	848.3

LTE Band 7 Channel and Frequency List				
BW [MHz]	Channel/Frequency(MHz)	Lowest	Middle	Highest
20	Channel	20850	21100	21350
	Frequency	2510	2535	2560
15	Channel	20825	21100	21375
	Frequency	2507.5	2535	2562.5
10	Channel	20800	21100	21400
	Frequency	2505	2535	2565
5	Channel	20775	21100	21425
	Frequency	2502.5	2535	2567.5

LTE Band 12 Channel and Frequency List				
BW [MHz]	Channel/Frequency(MHz)	Lowest	Middle	Highest
10	Channel	23060	23095	23130
	Frequency	704	707.5	711
5	Channel	23035	23095	23155
	Frequency	701.5	707.5	713.5
3	Channel	23025	23095	23165
	Frequency	700.5	707.5	714.5
1.4	Channel	23017	23095	23173
	Frequency	699.7	707.5	715.3



LTE Band 17 Channel and Frequency List				
BW [MHz]	Channel/Frequency(MHz)	Lowest	Middle	Highest
10	Channel	23780	23790	23800
	Frequency	709	710	711
5	Channel	23755	23790	23825
	Frequency	706.5	710	713.5

LTE Band 26 Channel and Frequency List				
BW [MHz]	Channel/Frequency(MHz)	Lowest	Middle	Highest
15	Channel	26865	26915	26965
	Frequency	831.5	836.5	841.5
10	Channel	26840	26915	26990
	Frequency	829	836.5	844
5	Channel	26815	26915	27015
	Frequency	826.5	836.5	846.5
3	Channel	26805	26915	27025
	Frequency	825.5	836.5	847.5
1.4	Channel	26797	26915	27033
	Frequency	824.7	836.5	848.3

LTE Band 38 Channel and Frequency List				
BW [MHz]	Channel/Frequency(MHz)	Lowest	Middle	Highest
20	Channel	37850	38000	38150
	Frequency	2580	2595	2610
15	Channel	37825	38000	38175
	Frequency	2577.5	2595	2612.5
10	Channel	37800	38000	38200
	Frequency	2575	2595	2615
5	Channel	37775	38000	38225
	Frequency	2572.5	2595	2617.5



LTE Band 41 Channel and Frequency List				
BW [MHz]	Channel/Frequency(MHz)	Lowest	Middle	Highest
20	Channel	39750	40620	41490
	Frequency	2506.0	2593.0	2680.0
15	Channel	39725	40620	41515
	Frequency	2503.5	2593.0	2682.5
10	Channel	39700	40620	41540
	Frequency	2501	2593	2685
5	Channel	39675	40620	41565
	Frequency	2498.5	2593.0	2687.5

LTE Band 38 Channel and Frequency List					
BW [MHz]	Channel/Frequency(MHz)	Lowest	Middle	Highest	
20 + 20	PCC	Channel	2580.0	2585.1	2590.2
		Frequency	37850	37901	37952
	SCC	Channel	2599.8	2604.9	2610.0
		Frequency	38048	38099	38150
15+ 15	PCC	Channel	2577.5	2587.5	2597.5
		Frequency	37825	37925	38025
	SCC	Channel	2592.5	2602.5	2612.5
		Frequency	37975	38075	38175



2.5.1

LTE Band 41 Channel and Frequency List					
BW [MHz]	Channel/Frequency(MHz)		Lowest	Middle	Highest
20 + 20	PCC	Channel	2555.0	2590.1	2625.2
		Frequency	40240	40591	40942
	SCC	Channel	2574.8	2609.9	2645.0
		Frequency	40438	40789	41140
20 + 15	PCC	Channel	2555.0	2592.6	2630.4
		Frequency	40240	40616	40994
	SCC	Channel	2572.1	2609.7	2647.5
		Frequency	40411	40787	41165
15 + 20	PCC	Channel	2552.5	2590.3	2627.9
		Frequency	40215	40593	40969
	SCC	Channel	2567.5	2607.4	2645.0
		Frequency	40386	40764	41140
20 + 10	PCC	Channel	2555.0	2595.1	2635.6
		Frequency	40240	40641	41046
	SCC	Channel	2569.4	2609.5	2650.0
		Frequency	40384	40785	41190
10 + 20	PCC	Channel	2550.0	2590.6	2630.6
		Frequency	40190	40596	40996
	SCC	Channel	2564.4	2605.0	2645.0
		Frequency	40334	40740	41140
20 + 5	PCC	Channel	2555.0	2597.5	2640.8
		Frequency	40240	40665	41098
	SCC	Channel	2566.7	2609.2	2652.5
		Frequency	40357	40782	41215
5 + 20	PCC	Channel	2547.5	2590.8	2633.3
		Frequency	40165	40598	41023
	SCC	Channel	2559.2	2602.5	2645.0
		Frequency	40282	40715	41140
15+ 15	PCC	Channel	2552.5	2592.5	2632.5
		Frequency	40215	40615	41015
	SCC	Channel	2567.5	2607.5	2647.5
		Frequency	40365	40765	41165

3 Conducted Test Items

3.1 Measuring Instruments

See list of measuring instruments of this test report.

3.2 Test Setup

3.2.1 Conducted Output Power

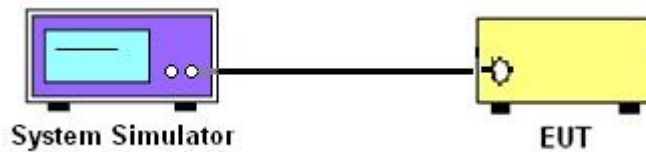

3.2.2 Peak-to-Average Ratio, Occupied Bandwidth ,Conducted Band-Edge and Conducted Spurious Emission

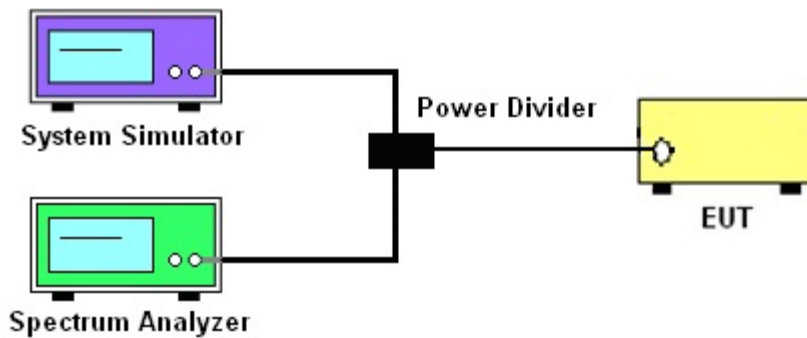

3.2.3 Frequency Stability

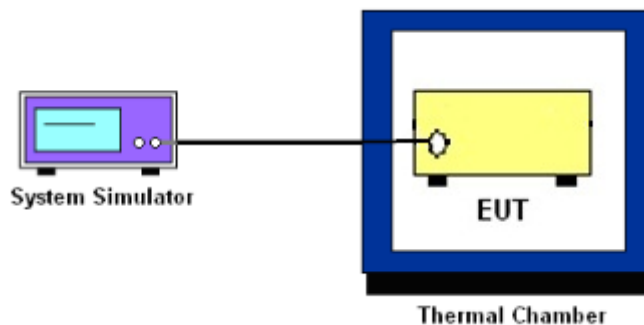

3.3 Test Result of Conducted Test

Please refer to Appendix A.



3.4 Conducted Output Power and ERP/EIRP

3.4.1 Description of the Conducted Output Power Measurement and ERP/EIRP Measurement

A system simulator was used to establish communication with the EUT. Its parameters were set to force the EUT transmitting at maximum output power. The measured power in the radio frequency on the transmitter output terminals shall be reported.

The ERP of mobile transmitters must not exceed 7 Watts for LTE Band 5 and Band 26.

The ERP of mobile transmitters must not exceed 3 Watts for LTE Band 12 and Band 17.

The EIRP of mobile transmitters must not exceed 2 Watts for LTE Band 2, Band 7, Band 38 and Band 41.

The EIRP of mobile transmitters must not exceed 1 Watts for LTE Band 4.

According to KDB 412172 D01 Power Approach,

$EIRP = P_T + G_T - L_C$, $ERP = EIRP - 2.15$, where

P_T = transmitter output power in dBm

G_T = gain of the transmitting antenna in dBi

L_C = signal attenuation in the connecting cable between the transmitter and antenna in dB

3.4.2 Test Procedures

1. The transmitter output port was connected to the system simulator.
2. Set EUT at maximum power through the system simulator.
3. Select lowest, middle, and highest channels for each band and different modulation.
4. Measure and record the power level from the system simulator.



3.5 Peak-to-Average Ratio

3.5.1 Description of the PAR Measurement

Power Complementary Cumulative Distribution Function (CCDF) curves provide a means for characterizing the power peaks of a digitally modulated signal on a statistical basis. A CCDF curve depicts the probability of the peak signal amplitude exceeding the average power level. Most contemporary measurement instrumentation include the capability to produce CCDF curves for an input signal provided that the instrument's resolution bandwidth can be set wide enough to accommodate the entire input signal bandwidth. In measuring transmissions in this band using an average power technique, the peak-to-average ratio (PAR) of the transmission may not exceed 13 dB.

3.5.2 Test Procedures

1. The testing follows FCC KDB 971168 v02r02 Section 5.7.1.
2. The EUT was connected to spectrum and system simulator via a power divider.
3. Set the CCDF (Complementary Cumulative Distribution Function) option in spectrum analyzer.
4. The highest RF powers were measured and recorded the maximum PAPR level associated with a probability of 0.1 %.
5. Record the deviation as Peak to Average Ratio.



3.6 Occupied Bandwidth

3.6.1 Description of Occupied Bandwidth Measurement

The occupied bandwidth is the width of a frequency band such that, below the lower and above the upper frequency limits, the mean powers emitted are each equal to a specified percentage 0.5% of the total mean transmitted power.

The 26 dB emission bandwidth is defined as the frequency range between two points, one above and one below the carrier frequency, at which the spectral density of the emission is attenuated 26 dB below the maximum in-band spectral density of the modulated signal. Spectral density (power per unit bandwidth) is to be measured with a detector of resolution bandwidth equal to approximately 1.0% of the emission bandwidth.

3.6.2 Test Procedures

1. The testing follows FCC KDB 971168 v02r02 Section 4.2.
2. The EUT was connected to spectrum analyzer and system simulator via a power divider.
3. The spectrum analyzer center frequency is set to the nominal EUT channel center frequency. The span range for the spectrum analyzer shall be between two and five times the anticipated OBW.
4. The nominal resolution bandwidth (RBW) shall be in the range of 1 to 5 % of the anticipated OBW, and the VBW shall be at least 3 times the RBW.
5. Set the detection mode to peak, and the trace mode to max hold.
6. Determine the reference value: Set the EUT to transmit a modulated signal. Allow the trace to stabilize. Set the spectrum analyzer marker to the highest level of the displayed trace.
(this is the reference value)
7. Determine the “-26 dB down amplitude” as equal to (Reference Value – X).
8. Place two markers, one at the lowest and the other at the highest frequency of the envelope of the spectral display such that each marker is at or slightly below the “-X dB down amplitude” determined in step 6. If a marker is below this “-X dB down amplitude” value it shall be placed as close as possible to this value. The OBW is the positive frequency difference between the two markers.
9. Use the 99 % power bandwidth function of the spectrum analyzer and report the measured bandwidth.



3.7 Conducted Band Edge

3.7.1 Description of Conducted Band Edge Measurement

22.917(a)

For operations in the 824 – 849 MHz band, the FCC limit is $43 + 10\log_{10}(P[\text{Watts}])$ dB below the transmitter power $P(\text{Watts})$ in a 100kHz bandwidth. However, in the 1MHz bands immediately outside and adjacent to the licensee's frequency block, a resolution bandwidth of at least one percent of the emission bandwidth of the fundamental emission of the transmitter may be employed.

24.238 (a)

For operations in the 1850-1910 and 1930-1990 MHz band, the FCC limit is $43 + 10\log_{10}(P[\text{Watts}])$ dB below the transmitter power $P(\text{Watts})$ in a 1MHz bandwidth. However, in the 1 MHz bands immediately outside and adjacent to the frequency block a resolution bandwidth of at least one percent of the emission bandwidth of the fundamental emission of the transmitter may be employed.

27.53 (g)

For operations in the 698 -746 MHz band, the FCC limit is $43 + 10\log_{10}(P[\text{Watts}])$ dB below the transmitter power $P(\text{Watts})$ in a 100 kHz bandwidth. However, in the 100 kilohertz bands immediately outside and adjacent to a licensee's frequency block, a resolution bandwidth of at least 30 kHz may be employed.

27.53 (h)

For operations in the 1710 – 1755 MHz band, the FCC limit is $43 + 10\log_{10}(P[\text{Watts}])$ dB below the transmitter power $P(\text{Watts})$ in a 1 MHz bandwidth. However, in the 1MHz bands immediately outside and adjacent to the licensee's frequency block, a resolution bandwidth of at least one percent of the emission bandwidth of the fundamental emission of the transmitter may be employed.



27.53(m)(4)

For mobile digital stations, the attenuation factor shall be not less than $40 + 10 \log (P)$ dB on all frequencies between the channel edge and 5 megahertz from the channel edge, $43 + 10 \log (P)$ dB on all frequencies between 5 megahertz and X megahertz from the channel edge, and $55 + 10 \log (P)$ dB on all frequencies more than X megahertz from the channel edge, where X is the greater of 6 megahertz or the actual emission bandwidth as defined in paragraph (m)(6) of this section. In addition, the attenuation factor shall not be less that $43 + 10 \log (P)$ dB on all frequencies between 2490.5 MHz and 2496 MHz and $55 + 10 \log (P)$ dB at or below 2490.5 MHz. Mobile Satellite Service licensees operating on frequencies below 2495 MHz may also submit a documented interference complaint against BRS licensees operating on channel BRS Channel 1 on the same terms and conditions as adjacent channel BRS or EBS licensees.

3.7.2 Test Procedures

1. The testing follows FCC KDB 971168 v02r02 Section 6.0.
2. The EUT was connected to spectrum analyzer and system simulator via a power divider.
3. The band edges of low and high channels for the highest RF powers were measured.
4. Set RBW \geq 1% EBW in the 1MHz band immediately outside and adjacent to the band edge.
5. Beyond the 1 MHz band from the band edge, RBW=1MHz was used.
6. Set spectrum analyzer with RMS detector.
7. The RF fundamental frequency should be excluded against the limit line in the operating frequency band.
8. Checked that all the results comply with the emission limit line.
The limit line is derived from $43 + 10\log(P)$ dB below the transmitter power P(Watts)
9. For LTE Band 7, 38, 41, the other 40 dB, and 55 dB have additionally applied same calculation above.



3.8 Conducted Spurious Emission

3.8.1 Description of Conducted Spurious Emission Measurement

The power of any emission outside of the authorized operating frequency ranges must be lower than the transmitter power (P) by a factor of at least $43 + 10 \log (P)$ dB.

For Band 7, 38, 41:

The power of any emission outside of the authorized operating frequency ranges must be lower than the transmitter power (P) by a factor of at least $55 + 10 \log (P)$ dB.

It is measured by means of a calibrated spectrum analyzer and scanned from 30 MHz up to a frequency including its 10th harmonic.

3.8.2 Test Procedures

1. The testing follows FCC KDB 971168 v02r02 Section 6.0.
2. The EUT was connected to spectrum analyzer and system simulator via a power divider.
3. The RF output of EUT was connected to the spectrum analyzer by RF cable and attenuator. The path loss was compensated to the results for each measurement.
4. The middle channel for the highest RF power within the transmitting frequency was measured.
5. The conducted spurious emission for the whole frequency range was taken.
6. Make the measurement with the spectrum analyzer's RBW = 1MHz, VBW = 3MHz.
7. Set spectrum analyzer with RMS detector.
8. Taking the record of maximum spurious emission.
9. The RF fundamental frequency should be excluded against the limit line in the operating frequency band.
10. The limit line is derived from $43 + 10\log(P)$ dB below the transmitter power P(Watts)
11. For Band 7, 38, 41
The limit line is derived from $55 + 10\log(P)$ dB below the transmitter power P(Watts)



3.9 Frequency Stability

3.9.1 Description of Frequency Stability Measurement

The frequency stability shall be measured by variation of ambient temperature and variation of primary supply voltage to ensure that the fundamental emission stays within the authorized frequency block. The frequency stability of the transmitter shall be maintained within $\pm 0.00025\%$ ($\pm 2.5\text{ppm}$) of the center frequency.

3.9.2 Test Procedures for Temperature Variation

1. The testing follows FCC KDB 971168 v02r02 Section 9.0.
2. The EUT was set up in the thermal chamber and connected with the system simulator.
3. With power OFF, the temperature was decreased to -30°C and the EUT was stabilized before testing. Power was applied and the maximum change in frequency was recorded within one minute.
4. With power OFF, the temperature was raised in 10°C step up to 50°C . The EUT was stabilized at each step for at least half an hour. Power was applied and the maximum frequency change was recorded within one minute.

3.9.3 Test Procedures for Voltage Variation

1. The testing follows FCC KDB 971168 v02r02 Section 9.0.
2. The EUT was placed in a temperature chamber at $20\pm 5^{\circ}\text{C}$ and connected with the system simulator.
3. The power supply voltage to the EUT was varied from 85% to 115% of the nominal value measured at the input to the EUT.
4. The variation in frequency was measured for the worst case.

4 Radiated Test Items

4.1 Measuring Instruments

See list of measuring instruments of this test report.

4.2 Test Setup

4.2.1 For radiated test from 30MHz to 1GHz

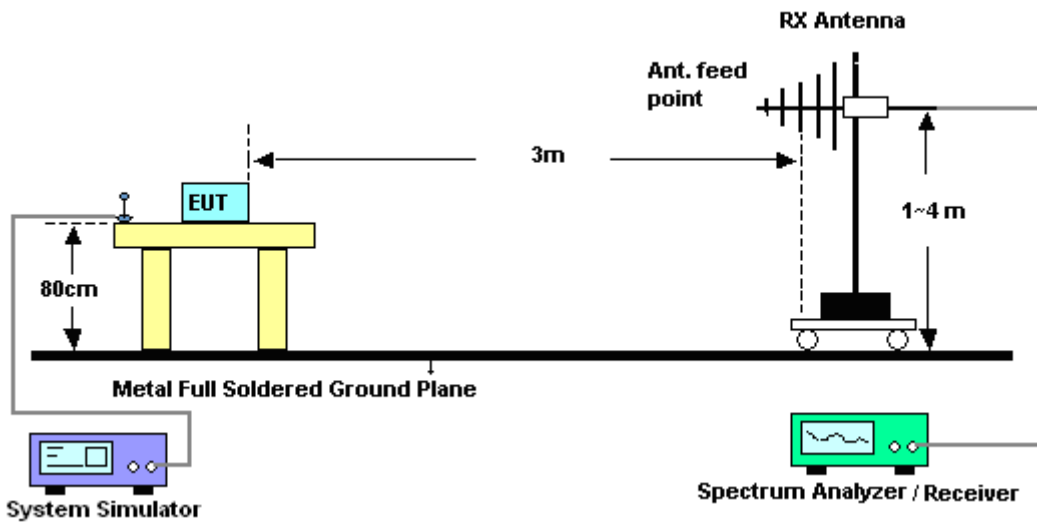

4.2.2 For radiated test above 1GHz

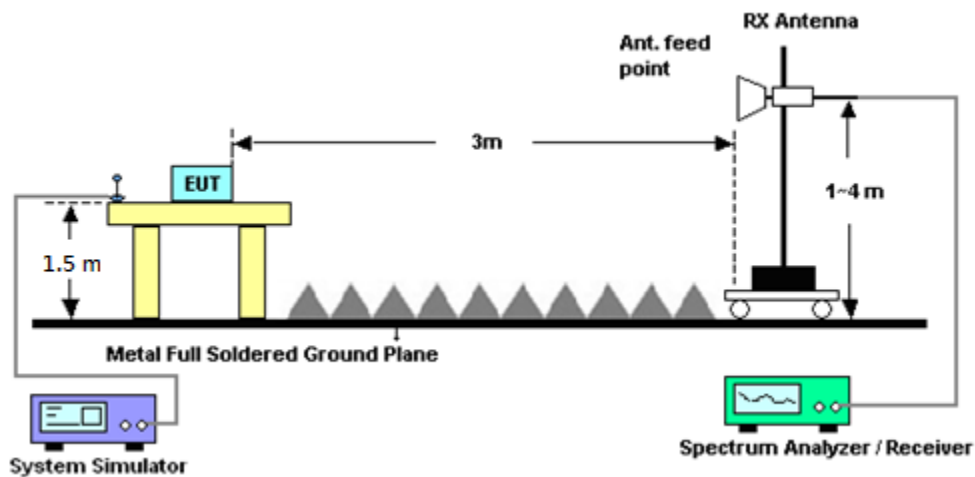

4.3 Test Result of Radiated Test

Please refer to Appendix B.



4.4 Radiated Spurious Emission

4.4.1 Description of Radiated Spurious Emission

The radiated spurious emission was measured by substitution method according to ANSI / TIA / EIA-603-D-2010. The power of any emission outside of the authorized operating frequency ranges must be attenuated below the transmitter power (P) by a factor of at least $43 + 10 \log (P)$ dB.

For Band 7, 38, 41

The power of any emission outside of the authorized operating frequency ranges must be attenuated below the transmitter power (P) by a factor of at least $55 + 10 \log (P)$ dB.

For LTE Band 12,17

For operations in the 746-758 MHz, 775-788 MHz, and 805-806 MHz bands, emissions in the band 1559-1610 MHz shall be limited to -70 dBW/MHz equivalent isotropically radiated power (EIRP) for wideband signals, and -80 dBW EIRP for discrete emissions of less than 700 Hz bandwidth.

The spectrum is scanned from 30 MHz up to a frequency including its 10th harmonic.

4.4.2 Test Procedures

1. The testing follows FCC KDB 971168 v02r02 Section 5.8 and ANSI / TIA-603-D-2010 Section 2.2.12.
2. The EUT was placed on a turntable with 0.8 meter for frequency below 1GHz and 1.5 meter for frequency above 1GHz respectively above ground.
3. The EUT was set 3 meters from the receiving antenna, which was mounted on the antenna tower.
4. The table was rotated 360 degrees to determine the position of the highest spurious emission.
5. The height of the receiving antenna is varied between one meter and four meters to search the maximum spurious emission for both horizontal and vertical polarizations.
6. Make the measurement with the spectrum analyzer's RBW = 1MHz, VBW = 3MHz, taking the record of maximum spurious emission.
7. A horn antenna was substituted in place of the EUT and was driven by a signal generator.
8. Tune the output power of signal generator to the same emission level with EUT maximum spurious emission.
9. Taking the record of output power at antenna port.
10. Repeat step 7 to step 8 for another polarization.
11. The RF fundamental frequency should be excluded against the limit line in the operating frequency band.

The limit line is derived from $43 + 10\log(P)$ dB below the transmitter power P(Watts)

12. For Band 7, 38, 41:

The limit line is derived from $55 + 10\log(P)$ dB below the transmitter power P(Watts)

EIRP (dBm) = S.G. Power – Tx Cable Loss + Tx Antenna Gain

ERP (dBm) = EIRP - 2.15



5 List of Measuring Equipment

Instrument	Manufacturer	Model No.	Serial No.	Characteristics	Calibration Date	Test Date	Due Date	Remark
LTE Base Station	Anritsu	MT8820C	6201432821	GSM/GPRS /WCDMA/LTE	Oct. 11, 2016	May 02, 2017~ May 31, 2017	Oct. 10, 2017	Conducted (TH05-HY)
Spectrum Analyzer	Rohde & Schwarz	FSV40	101397	10Hz~40GHz	Nov. 04, 2016	May 02, 2017~ May 31, 2017	Nov. 03, 2017	Conducted (TH05-HY)
Temperature Chamber	ESPEC	SH-641	92013720	-30 度~70 度	Sep. 01, 2016	May 02, 2017~ May 31, 2017	Aug. 31, 2017	Conducted (TH05-HY)
Programmable Power Supply	GW Instek	PSS-2005	EL890001	1V~20V 0.5A~5A	Oct. 03, 2016	May 02, 2017~ May 31, 2017	Oct. 02, 2017	Conducted (TH05-HY)
Bilog Antenna	TESEQ	CBL 6111D&008	35419&03	30MHz to 1GHz	Jan. 07, 2017	May 17, 2017~ May 25, 2017	Jan. 06, 2018	Radiation (03CH07-HY)
Double Ridge Horn Antenna	ESCO	3117	00075962	1GHz ~ 18GHz	Aug. 19, 2016	May 17, 2017~ May 25, 2017	Aug. 18, 2017	Radiation (03CH07-HY)
EMI Test Receiver	Keysight	N9038A(MXE)	MY54130085	20Hz ~ 8.4GHz	Oct. 26, 2016	May 17, 2017~ May 25, 2017	Oct. 25, 2017	Radiation (03CH07-HY)
Loop Antenna	Rohde & Schwarz	HFH2-Z2	100315	9 kHz~30 MHz	May 15, 2017	May 17, 2017~ May 25, 2017	May 14, 2019	Radiation (03CH07-HY)
Preamplifier	MITEQ	AMF-7D-00 101800-30-1	1590075	1GHz ~ 18GHz	Apr. 25, 2017	May 17, 2017~ May 25, 2017	Apr. 24, 2018	Radiation (03CH07-HY)
Preamplifier	COM-POWER	PA-103A	161241	10MHz-1GHz	Mar. 14, 2017	May 17, 2017~ May 25, 2017	Mar. 13, 2018	Radiation (03CH07-HY)
Spectrum Analyzer	Agilent	N9010A	MY53470118	10Hz~44GHz	Apr. 17, 2017	May 17, 2017~ May 25, 2017	Apr. 16, 2018	Radiation (03CH07-HY)
Antenna Mast	Max-Full	MFA520BS	N/A	1m~4m	N/A	May 17, 2017~ May 25, 2017	N/A	Radiation (03CH07-HY)
Turn Table	ChainTek	Chaintek 3000	N/A	0~360 Degree	N/A	May 17, 2017~ May 25, 2017	N/A	Radiation (03CH07-HY)
Preamplifier	MITEQ	JS44-18004 000-33-8P	1840917	18GHz ~ 40GHz	Jun. 14, 2016	May 17, 2017~ May 25, 2017	Jun. 13, 2017	Radiation (03CH07-HY)
SHF-EHF Horn Antenna	SCHWARZBECK	BBHA 9170	BBHA9170576	18GHz ~ 40GHz	Apr. 27, 2017	May 17, 2017~ May 25, 2017	Apr. 26, 2018	Radiation (03CH07-HY)
Signal Generator	Anritsu	MG3694C	163401	0.1Hz~40GHz	Jan. 04, 2017	May 17, 2017~ May 25, 2017	Jan. 03, 2018	Radiation (03CH07-HY)



6 Uncertainty of Evaluation

Uncertainty of Radiated Emission Measurement (30 MHz ~ 1000 MHz)

Measuring Uncertainty for a Level of Confidence of 95% ($U = 2Uc(y)$)	3.05
---	------

Uncertainty of Radiated Emission Measurement (1 GHz ~ 18 GHz)

Measuring Uncertainty for a Level of Confidence of 95% ($U = 2Uc(y)$)	3.44
---	------

Uncertainty of Radiated Emission Measurement (18 GHz ~ 40 GHz)

Measuring Uncertainty for a Level of Confidence of 95% ($U = 2Uc(y)$)	3.95
---	------



Appendix A. Test Results of Conducted Test

Conducted Output Power(Average power)

LTE Band 2 Maximum Average Power [dBm]						
BW [MHz]	RB Size	RB Offset	Mod	Lowest	Middle	Highest
20	1	0	QPSK	22.48	22.61	22.76
20	1	49		22.15	22.30	22.52
20	1	99		22.30	22.43	22.53
20	50	0		21.37	21.47	21.73
20	50	24		21.33	21.42	21.66
20	50	50		21.29	21.41	21.68
20	100	0		21.33	21.46	21.67
20	1	0	16-QAM	21.78	21.88	21.98
20	1	49		21.42	21.60	21.78
20	1	99		21.56	21.66	21.75
20	50	0		20.39	20.53	20.72
20	50	24		20.32	20.46	20.67
20	50	50		20.29	20.42	20.67
20	100	0		20.33	20.46	20.70
20	1	0	64-QAM	21.74	21.82	21.94
20	1	49		21.36	21.53	21.72
20	1	99		21.51	21.60	21.71
20	50	0		20.35	20.46	20.70
20	50	24		20.31	20.43	20.68
20	50	50		20.28	20.38	20.64
20	100	0		20.33	20.40	20.66
15	1	0	QPSK	22.27	22.43	22.63
15	1	37		22.09	22.29	22.50
15	1	74		22.11	22.29	22.53
15	36	0		21.29	21.44	21.68
15	36	20		21.26	21.43	21.66
15	36	39		21.23	21.38	21.65
15	75	0		21.29	21.43	21.67
15	1	0	16-QAM	21.56	21.70	21.86
15	1	37		21.40	21.63	21.83
15	1	74		21.39	21.56	21.73
15	36	0		20.31	20.47	20.71
15	36	20		20.29	20.43	20.69
15	36	39		20.23	20.39	20.66
15	75	0		20.29	20.42	20.70
15	1	0	64-QAM	21.50	21.67	21.83
15	1	37		21.34	21.54	21.74
15	1	74		21.34	21.52	21.74
15	36	0		20.32	20.44	20.71
15	36	20		20.28	20.42	20.66
15	36	39		20.25	20.39	20.63
15	75	0		20.26	20.40	20.64



LTE Band 2 Maximum Average Power [dBm]						
BW [MHz]	RB Size	RB Offset	Mod	Lowest	Middle	Highest
10	1	0	QPSK	22.40	22.57	22.62
10	1	25		22.13	22.27	22.54
10	1	49		22.28	22.48	22.55
10	25	0		21.24	21.42	21.65
10	25	12		21.21	21.37	21.64
10	25	25		21.21	21.36	21.65
10	50	0		21.24	21.41	21.68
10	1	0	16-QAM	21.69	21.85	21.86
10	1	25		21.38	21.60	21.82
10	1	49		21.51	21.78	21.72
10	25	0		20.27	20.44	20.68
10	25	12		20.26	20.44	20.68
10	25	25		20.20	20.42	20.67
10	50	0		20.25	20.43	20.69
10	1	0	64-QAM	21.60	21.77	21.77
10	1	25		21.33	21.51	21.76
10	1	49		21.46	21.66	21.65
10	25	0		20.25	20.40	20.64
10	25	12		20.22	20.40	20.65
10	25	25		20.20	20.36	20.64
10	50	0		20.25	20.40	20.67
5	1	0	QPSK	22.09	22.27	22.53
5	1	12		22.02	22.20	22.49
5	1	24		22.06	22.25	22.53
5	12	0		21.14	21.36	21.63
5	12	7		21.15	21.34	21.62
5	12	13		21.12	21.32	21.59
5	25	0		21.12	21.30	21.61
5	1	0	16-QAM	21.39	21.58	21.82
5	1	12		21.34	21.55	21.75
5	1	24		21.36	21.55	21.66
5	12	0		20.17	20.38	20.65
5	12	7		20.18	20.39	20.66
5	12	13		20.14	20.33	20.60
5	25	0		20.16	20.34	20.63
5	1	0	64-QAM	21.35	21.51	21.80
5	1	12		21.26	21.45	21.70
5	1	24		21.28	21.44	21.67
5	12	0		20.15	20.36	20.61
5	12	7		20.17	20.37	20.66
5	12	13		20.16	20.36	20.64
5	25	0		20.13	20.32	20.60



LTE Band 2 Maximum Average Power [dBm]						
BW [MHz]	RB Size	RB Offset	Mod	Lowest	Middle	Highest
3	1	0	QPSK	22.06	22.26	22.54
3	1	8		22.05	22.24	22.54
3	1	14		22.04	22.25	22.55
3	8	0		21.14	21.34	21.62
3	8	4		21.13	21.35	21.65
3	8	7		21.10	21.31	21.65
3	15	0		21.11	21.32	21.60
3	1	0	16-QAM	21.32	21.57	21.73
3	1	8		21.33	21.57	21.69
3	1	14		21.31	21.55	21.62
3	8	0		20.21	20.40	20.69
3	8	4		20.24	20.44	20.70
3	8	7		20.20	20.39	20.68
3	15	0		20.17	20.36	20.65
3	1	0	64-QAM	21.29	21.50	21.71
3	1	8		21.28	21.48	21.64
3	1	14		21.27	21.45	21.68
3	8	0		20.15	20.36	20.61
3	8	4		20.17	20.37	20.66
3	8	7		20.12	20.34	20.63
3	15	0		20.13	20.32	20.63
1.4	1	0	QPSK	22.41	22.50	22.68
1.4	1	3		22.41	22.46	22.65
1.4	1	5		22.38	22.47	22.63
1.4	3	0		22.05	22.03	22.21
1.4	3	1		22.08	22.06	22.21
1.4	3	3		22.07	22.01	22.20
1.4	6	0		21.45	21.53	21.67
1.4	1	0	16-QAM	21.74	21.80	21.94
1.4	1	3		21.73	21.77	21.93
1.4	1	5		21.63	21.75	21.90
1.4	3	0		21.20	21.27	21.44
1.4	3	1		21.33	21.29	21.50
1.4	3	3		21.31	21.28	21.45
1.4	6	0		20.57	20.55	20.73
1.4	1	0	64-QAM	21.67	21.65	21.81
1.4	1	3		21.68	21.67	21.81
1.4	1	5		21.66	21.65	21.81
1.4	3	0		20.62	20.56	20.75
1.4	3	1		20.64	20.59	20.78
1.4	3	3		20.60	20.54	20.73
1.4	6	0		20.59	20.52	20.73



LTE Band 4 Maximum Average Power [dBm]						
BW [MHz]	RB Size	RB Offset	Mod	Lowest	Middle	Highest
20	1	0	QPSK	22.67	22.71	22.80
20	1	49		22.48	22.51	22.66
20	1	99		22.36	22.48	22.62
20	50	0		21.63	21.65	21.74
20	50	24		21.61	21.61	21.78
20	50	50		21.40	21.55	21.71
20	100	0		21.60	21.62	21.77
20	1	0	16-QAM	21.89	21.98	22.04
20	1	49		21.79	21.79	21.87
20	1	99		21.67	21.69	21.90
20	50	0		20.62	20.71	20.73
20	50	24		20.60	20.62	20.79
20	50	50		20.41	20.55	20.71
20	100	0		20.61	20.59	20.77
20	1	0	64-QAM	21.83	21.89	21.95
20	1	49		21.65	21.71	21.81
20	1	99		21.56	21.62	21.81
20	50	0		20.65	20.67	20.74
20	50	24		20.62	20.62	20.80
20	50	50		20.42	20.58	20.74
20	100	0		20.56	20.62	20.80
15	1	0	QPSK	22.61	22.70	22.69
15	1	37		22.46	22.51	22.64
15	1	74		22.40	22.50	22.64
15	36	0		21.61	21.63	21.81
15	36	20		21.59	21.60	21.75
15	36	39		21.39	21.55	21.71
15	75	0		21.57	21.62	21.77
15	1	0	16-QAM	21.89	21.99	22.00
15	1	37		21.77	21.81	21.92
15	1	74		21.70	21.76	21.95
15	36	0		20.60	20.65	20.81
15	36	20		20.58	20.59	20.75
15	36	39		20.38	20.53	20.70
15	75	0		20.57	20.59	20.77
15	1	0	64-QAM	21.82	21.91	21.91
15	1	37		21.64	21.69	21.82
15	1	74		21.57	21.69	21.84
15	36	0		20.65	20.66	20.84
15	36	20		20.59	20.62	20.79
15	36	39		20.43	20.57	20.73
15	75	0		20.56	20.60	20.78



LTE Band 4 Maximum Average Power [dBm]						
BW [MHz]	RB Size	RB Offset	Mod	Lowest	Middle	Highest
10	1	0	QPSK	22.52	22.59	22.79
10	1	25		22.44	22.50	22.68
10	1	49		22.43	22.47	22.64
10	25	0		21.54	21.59	21.79
10	25	12		21.56	21.59	21.74
10	25	25		21.51	21.54	21.72
10	50	0		21.52	21.55	21.74
10	1	0	16-QAM	21.78	21.87	22.00
10	1	25		21.73	21.81	21.91
10	1	49		21.72	21.73	21.93
10	25	0		20.53	20.58	20.77
10	25	12		20.54	20.57	20.78
10	25	25		20.49	20.52	20.72
10	50	0		20.52	20.59	20.73
10	1	0	64-QAM	21.67	21.78	21.90
10	1	25		21.64	21.70	21.87
10	1	49		21.61	21.66	21.83
10	25	0		20.54	20.61	20.79
10	25	12		20.54	20.59	20.78
10	25	25		20.50	20.55	20.74
10	50	0		20.54	20.58	20.76
5	1	0	QPSK	22.56	22.50	22.69
5	1	12		22.49	22.47	22.62
5	1	24		22.52	22.46	22.65
5	12	0		21.56	21.55	21.70
5	12	7		21.55	21.52	21.73
5	12	13		21.53	21.51	21.67
5	25	0		21.58	21.51	21.67
5	1	0	16-QAM	21.81	21.82	21.96
5	1	12		21.78	21.78	21.93
5	1	24		21.79	21.74	21.91
5	12	0		20.58	20.55	20.72
5	12	7		20.59	20.57	20.70
5	12	13		20.51	20.51	20.70
5	25	0		20.57	20.53	20.72
5	1	0	64-QAM	21.68	21.73	21.88
5	1	12		21.69	21.66	21.82
5	1	24		21.69	21.62	21.81
5	12	0		20.60	20.56	20.77
5	12	7		20.64	20.57	20.75
5	12	13		20.59	20.55	20.75
5	25	0		20.57	20.50	20.73



LTE Band 4 Maximum Average Power [dBm]						
BW [MHz]	RB Size	RB Offset	Mod	Lowest	Middle	Highest
3	1	0	QPSK	22.41	22.50	22.68
3	1	8		22.41	22.46	22.65
3	1	14		22.38	22.47	22.63
3	8	0		21.45	21.53	21.71
3	8	4		21.48	21.56	21.71
3	8	7		21.47	21.51	21.70
3	15	0		21.45	21.53	21.67
3	1	0	16-QAM	21.74	21.80	21.94
3	1	8		21.73	21.77	21.93
3	1	14		21.63	21.75	21.90
3	8	0		20.50	20.57	20.74
3	8	4		20.63	20.59	20.80
3	8	7		20.61	20.58	20.75
3	15	0		20.57	20.55	20.73
3	1	0	64-QAM	21.67	21.65	21.81
3	1	8		21.68	21.67	21.81
3	1	14		21.66	21.65	21.81
3	8	0		20.62	20.56	20.75
3	8	4		20.64	20.59	20.78
3	8	7		20.60	20.54	20.73
3	15	0		20.59	20.52	20.73
1.4	1	0	QPSK	22.41	22.42	22.59
1.4	1	3		22.49	22.48	22.66
1.4	1	5		22.40	22.41	22.57
1.4	3	0		22.36	22.46	22.64
1.4	3	1		22.41	22.53	22.68
1.4	3	3		22.37	22.43	22.65
1.4	6	0		21.38	21.46	21.63
1.4	1	0	16-QAM	21.70	21.72	21.87
1.4	1	3		21.76	21.79	21.94
1.4	1	5		21.68	21.71	21.84
1.4	3	0		21.47	21.50	21.67
1.4	3	1		21.53	21.52	21.72
1.4	3	3		21.48	21.48	21.64
1.4	6	0		20.54	20.53	20.73
1.4	1	0	64-QAM	21.60	21.60	21.79
1.4	1	3		21.65	21.68	21.82
1.4	1	5		21.61	21.59	21.77
1.4	3	0		21.59	21.60	21.76
1.4	3	1		21.62	21.63	21.79
1.4	3	3		21.60	21.59	21.76
1.4	6	0		20.47	20.44	20.65



LTE Band 5 Maximum Average Power [dBm]						
BW [MHz]	RB Size	RB Offset	Mod	Lowest	Middle	Highest
10	1	0	QPSK	23.15	23.02	22.97
10	1	25		23.04	22.93	22.78
10	1	49		23.04	22.86	22.68
10	25	0		22.14	22.03	21.96
10	25	12		22.13	21.98	21.85
10	25	25		22.13	21.94	21.79
10	50	0		22.09	21.99	21.81
10	1	0	16-QAM	22.31	22.26	22.23
10	1	25		22.26	22.18	22.01
10	1	49		22.29	22.12	21.88
10	25	0		21.13	21.05	20.98
10	25	12		21.12	21.03	20.87
10	25	25		21.13	20.95	20.78
10	50	0		21.10	21.02	20.86
10	1	0	64-QAM	21.36	21.28	21.27
10	1	25		21.27	21.25	21.06
10	1	49		21.31	21.15	20.97
10	25	0		20.22	20.15	20.09
10	25	12		20.21	20.15	19.99
10	25	25		20.26	20.05	19.90
10	50	0		20.21	20.11	19.94
5	1	0	QPSK	23.14	23.00	22.90
5	1	12		23.08	22.93	22.87
5	1	24		23.04	22.92	22.81
5	12	0		22.12	22.02	21.91
5	12	7		22.14	22.02	21.90
5	12	13		22.09	21.95	21.90
5	25	0		22.12	21.96	21.90
5	1	0	16-QAM	22.30	22.20	22.13
5	1	12		22.25	22.19	22.10
5	1	24		22.21	22.18	22.01
5	12	0		21.16	21.05	20.93
5	12	7		21.13	21.04	20.93
5	12	13		21.10	20.97	20.88
5	25	0		21.12	20.98	20.90
5	1	0	64-QAM	21.32	21.32	21.13
5	1	12		21.26	21.24	21.07
5	1	24		21.20	21.25	21.03
5	12	0		20.24	20.19	20.01
5	12	7		20.24	20.19	20.02
5	12	13		20.19	20.17	19.99
5	25	0		20.18	20.15	19.94



LTE Band 5 Maximum Average Power [dBm]						
BW [MHz]	RB Size	RB Offset	Mod	Lowest	Middle	Highest
3	1	0	QPSK	23.12	22.96	22.89
3	1	8		23.06	22.92	22.85
3	1	14		23.08	22.92	22.84
3	8	0		22.15	21.98	21.84
3	8	4		22.14	21.98	21.81
3	8	7		22.12	21.99	21.86
3	15	0		22.10	21.94	21.77
3	1	0	16-QAM	22.25	22.21	21.99
3	1	8		22.26	22.19	21.95
3	1	14		22.21	22.18	21.89
3	8	0		21.18	21.04	20.84
3	8	4		21.20	21.04	20.88
3	8	7		21.19	21.05	20.87
3	15	0		21.14	20.98	20.91
3	1	0	64-QAM	21.29	21.20	21.13
3	1	8		21.27	21.18	21.09
3	1	14		21.25	21.17	21.05
3	8	0		20.23	20.11	19.98
3	8	4		20.25	20.09	19.99
3	8	7		20.19	20.09	19.97
3	15	0		20.18	20.05	19.95
1.4	1	0	QPSK	23.02	22.88	22.76
1.4	1	3		23.07	22.95	22.80
1.4	1	5		22.97	22.83	22.73
1.4	3	0		23.05	22.93	22.81
1.4	3	1		23.10	22.99	22.86
1.4	3	3		23.07	22.91	22.80
1.4	6	0		22.05	21.92	21.80
1.4	1	0	16-QAM	22.23	22.16	21.99
1.4	1	3		22.25	22.18	22.06
1.4	1	5		22.16	22.13	21.97
1.4	3	0		22.05	21.93	21.83
1.4	3	1		22.11	21.97	21.87
1.4	3	3		22.06	21.92	21.80
1.4	6	0		21.12	20.99	20.89
1.4	1	0	64-QAM	21.25	21.22	21.04
1.4	1	3		21.28	21.27	21.07
1.4	1	5		21.23	21.20	20.98
1.4	3	0		21.20	21.15	20.96
1.4	3	1		21.25	21.20	21.02
1.4	3	3		21.19	21.17	20.98
1.4	6	0		20.10	20.06	19.86



LTE Band 7 Maximum Average Power [dBm]						
BW [MHz]	RB Size	RB Offset	Mod	Lowest	Middle	Highest
20	1	0	QPSK	22.85	22.89	22.73
20	1	49		22.69	22.72	22.59
20	1	99		22.70	22.68	22.66
20	50	0		21.88	21.79	21.77
20	50	24		21.79	21.80	21.69
20	50	50		21.81	21.81	21.69
20	100	0		21.78	21.82	21.65
20	1	0	16-QAM	22.13	22.13	22.01
20	1	49		21.95	21.99	21.87
20	1	99		21.96	21.95	21.93
20	50	0		20.88	20.81	20.78
20	50	24		20.80	20.85	20.68
20	50	50		20.80	20.81	20.67
20	100	0		20.78	20.80	20.65
20	1	0	64-QAM	21.02	21.09	20.93
20	1	49		20.87	20.91	20.79
20	1	99		20.86	20.90	20.85
20	50	0		19.89	19.81	19.77
20	50	24		19.81	19.83	19.69
20	50	50		19.80	19.84	19.70
20	100	0		19.78	19.80	19.70
15	1	0	QPSK	22.80	22.85	22.75
15	1	37		22.66	22.70	22.58
15	1	74		22.73	22.75	22.64
15	36	0		21.85	21.78	21.69
15	36	20		21.80	21.81	21.69
15	36	39		21.77	21.79	21.70
15	75	0		21.78	21.82	21.66
15	1	0	16-QAM	22.09	22.14	22.00
15	1	37		21.94	22.00	21.88
15	1	74		22.00	22.04	21.92
15	36	0		20.86	20.81	20.66
15	36	20		20.79	20.81	20.71
15	36	39		20.77	20.80	20.70
15	75	0		20.75	20.80	20.68
15	1	0	64-QAM	21.03	21.10	20.95
15	1	37		20.88	20.91	20.81
15	1	74		20.92	20.98	20.86
15	36	0		19.86	19.83	19.71
15	36	20		19.79	19.86	19.73
15	36	39		19.81	19.84	19.69
15	75	0		19.76	19.80	19.67



LTE Band 7 Maximum Average Power [dBm]						
BW [MHz]	RB Size	RB Offset	Mod	Lowest	Middle	Highest
10	1	0	QPSK	22.79	22.75	22.67
10	1	25		22.79	22.76	22.65
10	1	49		22.68	22.75	22.66
10	25	0		21.80	21.79	21.68
10	25	12		21.84	21.82	21.69
10	25	25		21.73	21.79	21.68
10	50	0		21.84	21.80	21.66
10	1	0	16-QAM	22.06	22.02	21.91
10	1	25		22.04	22.01	21.91
10	1	49		21.94	22.01	21.92
10	25	0		20.82	20.77	20.66
10	25	12		20.85	20.80	20.67
10	25	25		20.71	20.78	20.67
10	50	0		20.83	20.79	20.67
10	1	0	64-QAM	20.93	20.90	20.81
10	1	25		20.96	20.92	20.81
10	1	49		20.86	20.92	20.82
10	25	0		19.82	19.78	19.68
10	25	12		19.84	19.82	19.70
10	25	25		19.72	19.78	19.69
10	50	0		19.83	19.81	19.71
5	1	0	QPSK	22.76	22.73	22.66
5	1	12		22.76	22.76	22.66
5	1	24		22.76	22.76	22.66
5	12	0		21.81	21.77	21.68
5	12	7		21.81	21.81	21.73
5	12	13		21.82	21.77	21.66
5	25	0		21.77	21.78	21.69
5	1	0	16-QAM	22.02	21.98	21.89
5	1	12		22.03	22.02	21.91
5	1	24		21.99	21.98	21.89
5	12	0		20.83	20.78	20.71
5	12	7		20.86	20.82	20.70
5	12	13		20.80	20.77	20.69
5	25	0		20.81	20.77	20.67
5	1	0	64-QAM	20.92	20.92	20.83
5	1	12		20.93	20.92	20.82
5	1	24		20.91	20.91	20.82
5	12	0		19.81	19.80	19.70
5	12	7		19.89	19.87	19.76
5	12	13		19.82	19.81	19.73
5	25	0		19.80	19.80	19.68



LTE Band 12 Maximum Average Power [dBm]						
BW [MHz]	RB Size	RB Offset	Mod	Lowest	Middle	Highest
10	1	0	QPSK	22.95	22.74	22.79
10	1	25		22.87	22.81	22.79
10	1	49		22.81	22.76	22.80
10	25	0		21.85	21.86	21.83
10	25	12		21.93	21.88	21.85
10	25	25		21.90	21.87	21.94
10	50	0		21.92	21.87	21.82
10	1	0	16-QAM	22.03	22.00	22.03
10	1	25		22.13	22.02	22.02
10	1	49		22.02	22.03	22.10
10	25	0		20.85	20.90	20.83
10	25	12		20.95	20.91	20.84
10	25	25		20.89	20.85	20.88
10	50	0		20.93	20.89	20.83
10	1	0	64-QAM	21.04	21.00	21.07
10	1	25		21.15	21.09	21.03
10	1	49		21.07	21.04	21.09
10	25	0		19.94	19.99	19.94
10	25	12		20.04	20.00	19.96
10	25	25		20.00	19.95	19.99
10	50	0		20.01	20.00	19.93
5	1	0	QPSK	22.79	22.81	22.76
5	1	12		22.76	22.81	22.82
5	1	24		22.88	22.82	22.83
5	12	0		21.96	21.88	21.92
5	12	7		21.97	21.89	21.89
5	12	13		21.95	21.84	21.86
5	25	0		21.92	21.84	21.87
5	1	0	16-QAM	22.15	22.08	22.01
5	1	12		22.17	22.05	22.10
5	1	24		22.24	21.99	22.07
5	12	0		20.95	20.90	20.93
5	12	7		21.00	20.91	20.91
5	12	13		20.96	20.86	20.92
5	25	0		20.92	20.87	20.88
5	1	0	64-QAM	21.03	21.08	21.02
5	1	12		21.00	21.07	21.05
5	1	24		21.13	21.03	21.07
5	12	0		19.97	19.94	20.02
5	12	7		19.96	19.98	20.01
5	12	13		19.95	19.93	19.97
5	25	0		19.89	19.92	19.93



LTE Band 12 Maximum Average Power [dBm]						
BW [MHz]	RB Size	RB Offset	Mod	Lowest	Middle	Highest
3	1	0	QPSK	22.78	22.82	22.83
3	1	8		22.76	22.80	22.79
3	1	14		22.77	22.80	22.78
3	8	0		21.86	21.85	21.85
3	8	4		21.86	21.85	21.89
3	8	7		21.82	21.84	21.84
3	15	0		21.84	21.84	21.88
3	1	0	16-QAM	22.06	22.06	22.06
3	1	8		22.04	22.03	22.08
3	1	14		22.05	21.98	22.03
3	8	0		20.91	20.89	20.91
3	8	4		20.91	20.91	20.94
3	8	7		20.87	20.91	20.90
3	15	0		20.88	20.85	20.89
3	1	0	64-QAM	21.02	21.05	21.04
3	1	8		21.02	21.07	21.05
3	1	14		21.02	21.02	21.05
3	8	0		19.91	19.92	19.97
3	8	4		19.96	19.96	19.96
3	8	7		19.92	19.93	19.93
3	15	0		19.94	19.91	19.92
1.4	1	0	QPSK	22.82	22.72	22.73
1.4	1	3		22.90	22.77	22.76
1.4	1	5		22.81	22.70	22.69
1.4	3	0		22.85	22.78	22.76
1.4	3	1		22.93	22.83	22.84
1.4	3	3		22.85	22.78	22.77
1.4	6	0		21.85	21.77	21.78
1.4	1	0	16-QAM	22.06	21.94	22.01
1.4	1	3		22.17	22.01	22.06
1.4	1	5		22.08	21.93	21.99
1.4	3	0		21.89	21.79	21.81
1.4	3	1		21.91	21.83	21.84
1.4	3	3		21.90	21.75	21.76
1.4	6	0		20.92	20.84	20.84
1.4	1	0	64-QAM	20.98	21.02	21.01
1.4	1	3		21.01	21.06	21.03
1.4	1	5		20.98	20.96	20.98
1.4	3	0		20.91	20.95	20.95
1.4	3	1		20.98	20.97	20.99
1.4	3	3		20.95	20.91	20.94
1.4	6	0		19.82	19.85	19.82



LTE Band 17 Maximum Average Power [dBm]						
BW [MHz]	RB Size	RB Offset	Mod	Lowest	Middle	Highest
10	1	0	QPSK	22.70	22.70	22.84
10	1	25		22.82	22.79	22.78
10	1	49		22.77	22.75	22.70
10	25	0		21.90	21.88	21.87
10	25	12		21.93	21.89	21.90
10	25	25		21.89	21.87	21.84
10	50	0		21.89	21.86	21.86
10	1	0	16-QAM	22.01	21.98	22.02
10	1	25		22.02	22.02	22.03
10	1	49		22.05	22.03	22.00
10	25	0		20.91	20.88	20.89
10	25	12		20.93	20.89	20.90
10	25	25		20.87	20.85	20.83
10	50	0		20.91	20.88	20.86
10	1	0	64-QAM	20.99	20.95	21.07
10	1	25		21.02	21.01	21.02
10	1	49		21.01	20.99	20.98
10	25	0		19.96	19.96	19.93
10	25	12		19.99	19.97	19.96
10	25	25		19.95	19.90	19.90
10	50	0		19.97	19.97	19.94
5	1	0	QPSK	22.72	22.80	22.79
5	1	12		22.83	22.79	22.74
5	1	24		22.83	22.77	22.72
5	12	0		21.82	21.87	21.81
5	12	7		21.92	21.90	21.84
5	12	13		21.92	21.84	21.81
5	25	0		21.87	21.89	21.85
5	1	0	16-QAM	22.04	22.03	22.03
5	1	12		22.08	22.00	22.02
5	1	24		22.02	22.05	21.98
5	12	0		20.85	20.89	20.82
5	12	7		20.97	20.86	20.88
5	12	13		20.93	20.85	20.83
5	25	0		20.93	20.86	20.84
5	1	0	64-QAM	21.00	21.06	21.02
5	1	12		21.08	20.99	20.98
5	1	24		21.03	21.01	20.99
5	12	0		19.89	19.96	19.95
5	12	7		20.02	20.01	19.94
5	12	13		19.98	19.97	19.89
5	25	0		19.97	19.94	19.90



LTE Band 26 Maximum Average Power [dBm]						
BW [MHz]	RB Size	RB Offset	Mod	Lowest	Middle	Highest
15	1	0	QPSK	23.32	23.17	23.09
15	1	37		23.08	23.06	22.98
15	1	74		23.03	22.95	22.81
15	36	0		22.21	22.20	22.09
15	36	20		22.21	22.19	22.09
15	36	39		22.18	22.04	21.97
15	75	0		22.15	22.14	22.04
15	1	0	16-QAM	22.45	22.41	22.36
15	1	37		22.39	22.33	22.25
15	1	74		22.30	22.22	22.09
15	36	0		21.23	21.20	21.10
15	36	20		21.21	21.20	21.09
15	36	39		21.22	21.04	20.98
15	75	0		21.17	21.15	21.05
15	1	0	64-QAM	21.45	21.40	21.35
15	1	37		21.35	21.31	21.26
15	1	74		21.27	21.19	21.10
15	36	0		20.31	20.31	20.18
15	36	20		20.26	20.26	20.14
15	36	39		20.29	20.13	20.06
15	75	0		20.21	20.20	20.10
10	1	0	QPSK	23.19	23.17	23.04
10	1	25		23.15	23.07	22.95
10	1	49		23.14	23.00	22.86
10	25	0		22.20	22.15	22.04
10	25	12		22.16	22.14	22.03
10	25	25		22.14	22.06	21.97
10	50	0		22.15	22.14	22.01
10	1	0	16-QAM	22.41	22.34	22.29
10	1	25		22.36	22.30	22.18
10	1	49		22.36	22.24	22.07
10	25	0		21.19	21.16	21.04
10	25	12		21.21	21.17	21.05
10	25	25		21.13	21.09	20.95
10	50	0		21.18	21.11	21.02
10	1	0	64-QAM	21.42	21.33	21.26
10	1	25		21.35	21.29	21.18
10	1	49		21.33	21.22	21.08
10	25	0		20.26	20.21	20.13
10	25	12		20.27	20.22	20.12
10	25	25		20.23	20.12	20.03
10	50	0		20.24	20.22	20.11



LTE Band 26 Maximum Average Power [dBm]						
BW [MHz]	RB Size	RB Offset	Mod	Lowest	Middle	Highest
5	1	0	QPSK	23.22	23.14	22.97
5	1	12		23.16	23.09	22.95
5	1	24		23.15	23.05	22.90
5	12	0		22.32	22.15	21.98
5	12	7		22.28	22.13	21.97
5	12	13		22.30	22.12	21.94
5	25	0		22.28	22.10	21.98
5	1	0	16-QAM	22.52	22.32	22.19
5	1	12		22.50	22.30	22.18
5	1	24		22.47	22.28	22.09
5	12	0		21.35	21.16	20.99
5	12	7		21.33	21.18	21.00
5	12	13		21.29	21.10	20.94
5	25	0		21.31	21.14	20.97
5	1	0	64-QAM	21.40	21.27	21.17
5	1	12		21.36	21.26	21.15
5	1	24		21.39	21.25	21.12
5	12	0		20.29	20.24	20.05
5	12	7		20.32	20.23	20.07
5	12	13		20.30	20.20	20.05
5	25	0		20.27	20.18	20.02
3	1	0	QPSK	23.29	23.10	22.95
3	1	8		23.28	23.07	22.91
3	1	14		23.26	23.06	22.89
3	8	0		22.29	22.10	21.94
3	8	4		22.31	22.11	21.97
3	8	7		22.32	22.12	21.95
3	15	0		22.30	22.07	21.94
3	1	0	16-QAM	22.51	22.29	22.20
3	1	8		22.50	22.29	22.16
3	1	14		22.48	22.28	22.10
3	8	0		21.34	21.17	21.00
3	8	4		21.36	21.18	21.03
3	8	7		21.33	21.15	21.01
3	15	0		21.34	21.12	20.98
3	1	0	64-QAM	21.30	21.17	21.07
3	1	8		21.26	21.16	21.05
3	1	14		21.29	21.15	21.02
3	8	0		20.19	20.14	19.95
3	8	4		20.22	20.13	19.97
3	8	7		20.20	20.10	19.95
3	15	0		20.17	20.08	19.92



LTE Band 26 Maximum Average Power [dBm]						
BW [MHz]	RB Size	RB Offset	Mod	Lowest	Middle	Highest
1.4	1	0	QPSK	23.20	23.01	22.82
1.4	1	3		23.27	23.06	22.88
1.4	1	5		23.20	22.98	22.82
1.4	3	0		23.27	23.05	22.90
1.4	3	1		23.31	23.11	22.93
1.4	3	3		23.26	23.06	22.90
1.4	6	0		22.25	22.03	21.88
1.4	1	0	16-QAM	22.45	22.24	22.08
1.4	1	3		22.50	22.29	22.11
1.4	1	5		22.44	22.21	22.00
1.4	3	0		22.26	22.05	21.91
1.4	3	1		22.29	22.11	21.96
1.4	3	3		22.24	22.04	21.88
1.4	6	0		21.29	21.11	20.94
1.4	1	0	64-QAM	21.35	21.23	21.11
1.4	1	3		21.39	21.31	21.14
1.4	1	5		21.31	21.24	21.07
1.4	3	0		21.31	21.21	21.08
1.4	3	1		21.34	21.25	21.10
1.4	3	3		21.32	21.20	21.03
1.4	6	0		20.19	20.09	19.93



LTE Band 38 Maximum Average Power [dBm]						
BW [MHz]	RB Size	RB Offset	Mod	Lowest	Middle	Highest
20	1	0	QPSK	22.74	22.86	22.79
20	1	49		22.67	22.78	22.55
20	1	99		22.62	22.63	22.52
20	50	0		21.73	21.79	21.62
20	50	24		21.67	21.70	21.52
20	50	50		21.57	21.65	21.57
20	100	0		21.72	21.76	21.60
20	1	0	16-QAM	21.84	21.89	21.90
20	1	49		21.77	21.84	21.65
20	1	99		21.68	21.66	21.59
20	50	0		20.74	20.82	20.66
20	50	24		20.71	20.76	20.57
20	50	50		20.64	20.68	20.65
20	100	0		20.67	20.79	20.59
20	1	0	64-QAM	20.90	20.82	20.79
20	1	49		20.73	20.68	20.56
20	1	99		20.64	20.58	20.60
20	50	0		19.80	20.01	19.61
20	50	24		19.71	19.74	19.53
20	50	50		19.82	19.67	19.72
20	100	0		19.71	19.93	19.48
15	1	0	QPSK	22.85	22.84	22.73
15	1	37		22.76	22.77	22.57
15	1	74		22.71	22.73	22.54
15	36	0		21.76	21.72	21.64
15	36	20		21.76	21.68	21.58
15	36	39		21.68	21.58	21.56
15	75	0		21.72	21.73	21.61
15	1	0	16-QAM	21.87	21.90	21.80
15	1	37		21.81	21.82	21.67
15	1	74		21.78	21.72	21.63
15	36	0		20.74	20.74	20.66
15	36	20		20.75	20.69	20.60
15	36	39		20.69	20.55	20.57
15	75	0		20.76	20.82	20.60
15	1	0	64-QAM	20.85	20.79	20.81
15	1	37		20.75	20.74	20.73
15	1	74		20.75	20.69	20.76
15	36	0		19.87	19.87	19.83
15	36	20		19.71	19.68	19.63
15	36	39		19.62	19.63	19.75
15	75	0		19.91	19.88	19.63



LTE Band 38 Maximum Average Power [dBm]						
BW [MHz]	RB Size	RB Offset	Mod	Lowest	Middle	Highest
10	1	0	QPSK	22.72	22.75	22.59
10	1	25		22.68	22.70	22.59
10	1	49		22.76	22.66	22.53
10	25	0		21.71	21.71	21.56
10	25	12		21.68	21.66	21.62
10	25	25		21.69	21.49	21.48
10	50	0		21.75	21.66	21.57
10	1	0	16-QAM	21.86	21.80	21.72
10	1	25		21.77	21.84	21.69
10	1	49		21.80	21.69	21.59
10	25	0		20.73	20.67	20.62
10	25	12		20.71	20.71	20.62
10	25	25		20.72	20.64	20.57
10	50	0		20.76	20.71	20.61
10	1	0	64-QAM	20.85	20.85	20.76
10	1	25		20.87	20.83	20.71
10	1	49		20.82	20.74	20.68
10	25	0		19.77	19.87	19.69
10	25	12		19.77	19.77	19.74
10	25	25		19.82	19.63	19.64
10	50	0		19.82	19.73	19.71
5	1	0	QPSK	22.68	22.75	22.61
5	1	12		22.68	22.72	22.51
5	1	24		22.65	22.56	22.47
5	12	0		21.68	21.70	21.59
5	12	7		21.67	21.73	21.53
5	12	13		21.66	21.69	21.49
5	25	0		21.65	21.68	21.50
5	1	0	16-QAM	21.75	21.82	21.65
5	1	12		21.78	21.81	21.60
5	1	24		21.76	21.70	21.58
5	12	0		20.68	20.71	20.58
5	12	7		20.71	20.71	20.54
5	12	13		20.70	20.62	20.49
5	25	0		20.70	20.74	20.51
5	1	0	64-QAM	20.78	20.82	20.86
5	1	12		20.87	20.83	20.67
5	1	24		20.91	20.72	20.79
5	12	0		19.92	19.91	19.70
5	12	7		19.90	19.80	19.69
5	12	13		19.70	19.79	19.76
5	25	0		19.78	19.88	19.75



LTE Band 41 Maximum Average Power [dBm]						
BW [MHz]	RB Size	RB Offset	Mod	Lowest	Middle	Highest
20	1	0	QPSK	22.72	22.83	22.69
20	1	49		22.65	22.77	22.60
20	1	99		22.62	22.65	22.53
20	50	0		21.73	21.69	21.58
20	50	24		21.75	21.71	21.43
20	50	50		21.61	21.65	21.47
20	100	0		21.76	21.63	21.39
20	1	0	16-QAM	21.87	21.82	21.68
20	1	49		21.78	21.80	21.54
20	1	99		21.73	21.75	21.56
20	50	0		20.79	20.75	20.58
20	50	24		20.79	20.66	20.43
20	50	50		20.67	20.53	20.52
20	100	0		20.77	20.75	20.47
20	1	0	64-QAM	20.58	20.55	20.41
20	1	49		20.50	20.49	20.34
20	1	99		20.43	20.47	20.35
20	50	0		19.75	19.73	19.62
20	50	24		19.80	19.82	19.51
20	50	50		19.67	19.63	19.58
20	100	0		19.79	19.68	19.57
15	1	0	QPSK	22.69	22.75	22.63
15	1	37		22.65	22.64	22.53
15	1	74		22.60	22.73	22.50
15	36	0		21.69	21.61	21.41
15	36	20		21.73	21.71	21.38
15	36	39		21.72	21.53	21.28
15	75	0		21.68	21.63	21.47
15	1	0	16-QAM	21.84	21.82	21.73
15	1	37		21.75	21.83	21.61
15	1	74		21.67	21.76	21.61
15	36	0		20.67	20.70	20.51
15	36	20		20.73	20.67	20.43
15	36	39		20.70	20.61	20.34
15	75	0		20.77	20.63	20.47
15	1	0	64-QAM	20.51	20.61	20.47
15	1	37		20.46	20.51	20.33
15	1	74		20.45	20.51	20.37
15	36	0		19.73	19.70	19.52
15	36	20		19.74	19.68	19.45
15	36	39		19.74	19.66	19.34
15	75	0		19.74	19.70	19.45



LTE Band 41 Maximum Average Power [dBm]						
BW [MHz]	RB Size	RB Offset	Mod	Lowest	Middle	Highest
10	1	0	QPSK	22.64	22.62	22.67
10	1	25		22.62	22.69	22.71
10	1	49		22.69	22.64	22.60
10	25	0		21.62	21.68	21.47
10	25	12		21.67	21.69	21.48
10	25	25		21.66	21.59	21.39
10	50	0		21.66	21.68	21.48
10	1	0	16-QAM	21.75	21.82	21.67
10	1	25		21.72	21.80	21.68
10	1	49		21.73	21.73	21.59
10	25	0		20.66	20.61	20.52
10	25	12		20.68	20.68	20.49
10	25	25		20.66	20.54	20.48
10	50	0		20.73	20.65	20.56
10	1	0	64-QAM	20.47	20.51	20.39
10	1	25		20.47	20.53	20.37
10	1	49		20.45	20.39	20.35
10	25	0		19.74	19.65	19.55
10	25	12		19.77	19.67	19.66
10	25	25		19.71	19.60	19.57
10	50	0		19.70	19.66	19.64
5	1	0	QPSK	22.63	22.68	22.68
5	1	12		22.63	22.66	22.57
5	1	24		22.61	22.66	22.60
5	12	0		21.70	21.70	21.38
5	12	7		21.68	21.61	21.45
5	12	13		21.67	21.59	21.44
5	25	0		21.64	21.58	21.42
5	1	0	16-QAM	21.72	21.70	21.63
5	1	12		21.71	21.74	21.58
5	1	24		21.73	21.68	21.59
5	12	0		20.68	20.71	20.35
5	12	7		20.71	20.64	20.43
5	12	13		20.65	20.57	20.37
5	25	0		20.70	20.69	20.43
5	1	0	64-QAM	20.43	20.47	20.39
5	1	12		20.45	20.49	20.33
5	1	24		20.47	20.54	20.35
5	12	0		19.67	19.62	19.47
5	12	7		19.75	19.77	19.53
5	12	13		19.72	19.61	19.53
5	25	0		19.69	19.75	19.54



LTE Band 38_CA Maximum Average Power [dBm]									
BW [MHz]	PCC		SCC		Mod	Lowest	Middle	Highest	
	RB Size	RB Offset	RB Size	RB Offset					
20+20	0	0	1	99	QPSK	22.39	22.40	22.55	
20+20	1	0	0	0		23.27	23.18	22.99	
20+20	100	0	0	0		22.18	22.10	22.04	
20+20	100	0	100	0		21.62	21.86	21.86	
20+20	1	0	1	99		15.46	15.33	15.37	
20+20	1	0	1	0		19.34	19.43	19.03	
20+20	1	99	1	0		23.67	23.75	23.35	
20+20	100	0	1	99		19.57	19.39	19.27	
20+20	0	0	1	99		22.57	22.02	22.00	
20+20	1	0	0	0	16-QAM	22.75	22.67	22.60	
20+20	100	0	0	0		21.25	21.11	21.20	
20+20	100	0	100	0		20.95	20.54	20.57	
20+20	1	0	1	99		15.48	15.49	15.49	
20+20	1	0	1	0		19.47	19.47	19.37	
20+20	1	99	1	0		22.76	22.75	23.17	
20+20	100	0	1	99		19.63	19.46	19.34	
20+20	0	0	1	99		22.00	20.67	20.81	
20+20	1	0	0	0		21.36	21.34	21.39	
20+20	100	0	0	0	64-QAM	20.26	20.08	20.18	
20+20	100	0	100	0		20.93	20.87	20.88	
20+20	1	0	1	99		15.49	15.50	15.47	
20+20	1	0	1	0		19.44	19.50	19.27	
20+20	1	99	1	0		20.76	20.61	20.61	
20+20	100	0	1	99		19.64	19.23	19.34	
15+15	1	74	1	0		QPSK	23.97	23.30	23.76
15+15	1	74	1	0		16-QAM	22.97	22.96	22.95
15+15	1	74	1	0		64-QAM	20.81	20.80	20.66



LTE Band 41_CA Maximum Average Power [dBm]								
BW [MHz]	PCC		SCC		Mod	Lowest	Middle	Highest
	RB Size	RB Offset	RB Size	RB Offset				
20+20	0	0	1	99	QPSK	22.20	23.00	22.05
20+20	1	0	0	0		22.42	23.22	22.74
20+20	100	0	0	0		21.71	22.51	21.70
20+20	100	0	100	0		21.36	21.92	21.33
20+20	1	0	1	99		14.63	15.43	14.73
20+20	1	0	1	0		18.84	19.42	18.85
20+20	1	99	1	0		23.18	23.91	23.14
20+20	100	0	1	99		19.68	20.48	19.45
20+20	0	0	1	99	16-QAM	21.41	22.21	21.40
20+20	1	0	0	0		21.68	22.48	21.87
20+20	100	0	0	0		20.73	21.53	20.69
20+20	100	0	100	0		20.28	20.96	20.36
20+20	1	0	1	99		14.81	15.42	15.02
20+20	1	0	1	0		18.75	19.43	19.02
20+20	1	99	1	0		22.24	22.88	22.18
20+20	100	0	1	99		19.91	20.48	19.72
20+20	0	0	1	99	64-QAM	20.02	20.82	20.10
20+20	1	0	0	0		20.36	21.16	20.59
20+20	100	0	0	0		19.63	20.43	19.78
20+20	100	0	100	0		20.34	20.96	20.36
20+20	1	0	1	99		14.33	15.13	14.41
20+20	1	0	1	0		18.51	19.31	18.66
20+20	1	99	1	0		19.79	20.35	19.84
20+20	100	0	1	99		19.40	20.20	19.51
20+15	1	99	1	0	QPSK	22.98	23.84	22.97
20+15	1	99	1	0	16-QAM	22.23	22.75	22.11
20+15	1	99	1	0	64-QAM	20.02	20.41	20.01
15+20	1	74	1	0	QPSK	22.75	24.05	22.90
15+20	1	74	1	0	16-QAM	22.11	23.08	22.10
15+20	1	74	1	0	64-QAM	19.96	20.65	19.99
20+10	1	99	1	0	QPSK	22.87	23.90	22.92
20+10	1	99	1	0	16-QAM	22.21	22.89	22.09
20+10	1	99	1	0	64-QAM	20.01	20.54	19.95
10+20	1	49	1	0	QPSK	22.84	23.62	22.91
10+20	1	49	1	0	16-QAM	22.24	22.55	22.01
10+20	1	49	1	0	64-QAM	20.01	20.25	19.98
20+5	1	99	1	0	QPSK	22.84	23.53	22.86
20+5	1	99	1	0	16-QAM	22.19	22.61	22.10
20+5	1	99	1	0	64-QAM	20.06	20.31	20.08
5+20	1	24	1	0	QPSK	22.97	24.05	22.91
5+20	1	24	1	0	16-QAM	22.21	22.91	22.04
5+20	1	24	1	0	64-QAM	20.05	20.61	19.95
15+15	1	74	1	0	QPSK	22.94	23.55	22.85
15+15	1	74	1	0	16-QAM	22.21	22.65	22.19
15+15	1	74	1	0	64-QAM	20.01	20.01	20.06



LTE Band 2

Peak-to-Average Ratio

Mode	LTE Band 2 / 20MHz				
Mod.	QPSK		16QAM		Limit: 13dB
RB Size	1RB	Full RB	1RB	Full RB	Result
Lowest CH	3.94	4.7	4.78	5.65	PASS
Middle CH	3.86	4.93	4.55	6	
Highest CH	3.62	4.81	4.35	5.74	
Mod.	-		64QAM		Limit: 13dB
RB Size	1RB	Full RB	1RB	Full RB	Result
Lowest CH	-	-	4.64	5.77	PASS
Middle CH	-	-	4.84	6.06	
Highest CH	-	-	4.43	5.8	



LTE Band 2 / 20MHz / QPSK

Lowest Channel / 1RB

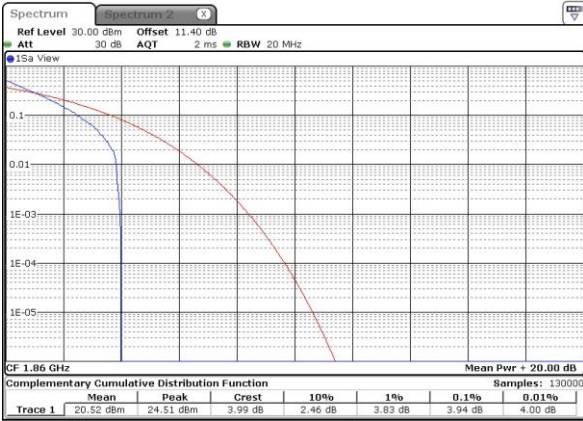

Date: 8 MAY 2017 23:48:21

Lowest Channel / Full RB

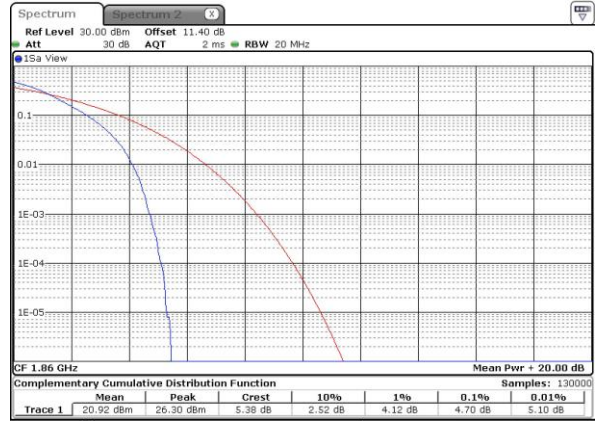

Date: 8 MAY 2017 23:48:32

Middle Channel / 1RB

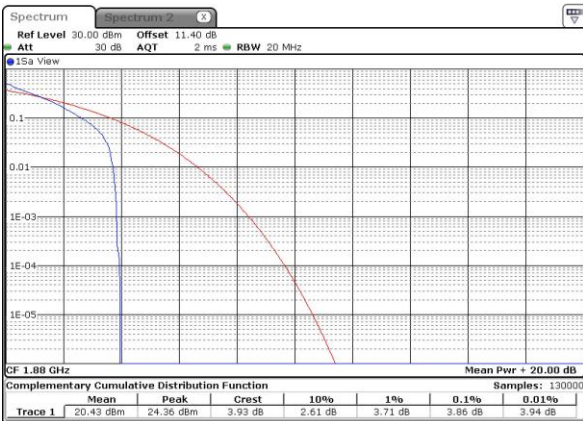

Date: 8 MAY 2017 23:48:44

Middle Channel / Full RB

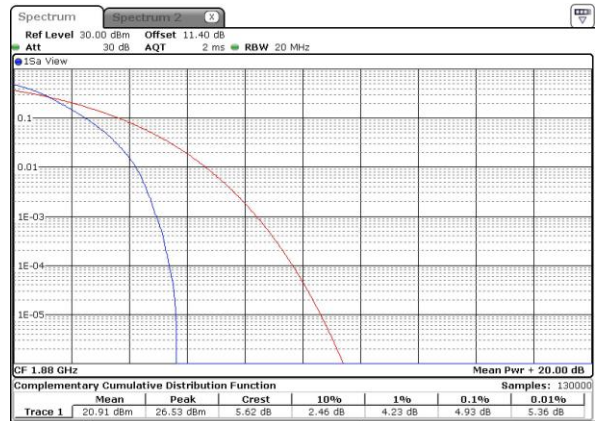

Date: 8 MAY 2017 23:48:54

Highest Channel / 1RB

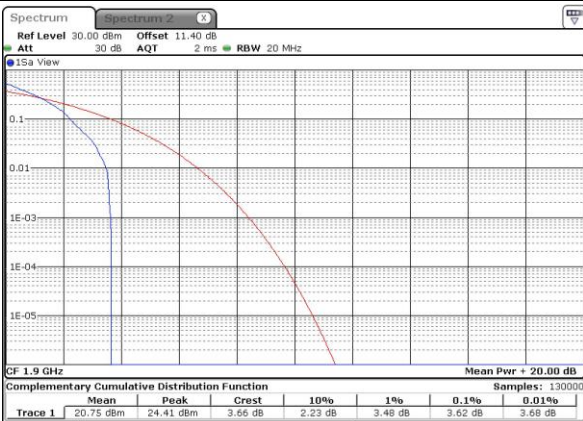

Date: 8 MAY 2017 23:49:04

Highest Channel / Full RB

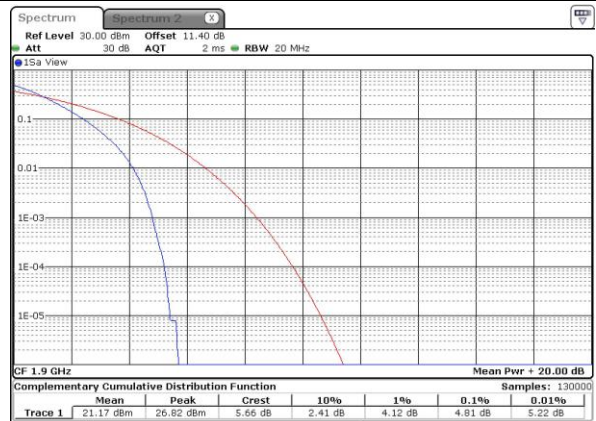

Date: 8 MAY 2017 23:49:14



LTE Band 2 / 20MHz / 16QAM

Lowest Channel / 1RB

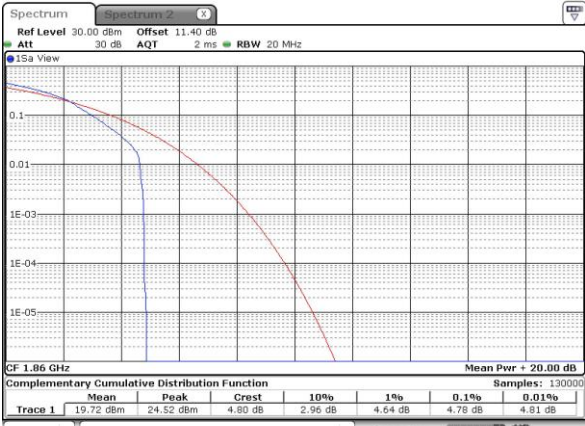

Date: 8 MAY 2017 23:46:40

Lowest Channel / Full RB

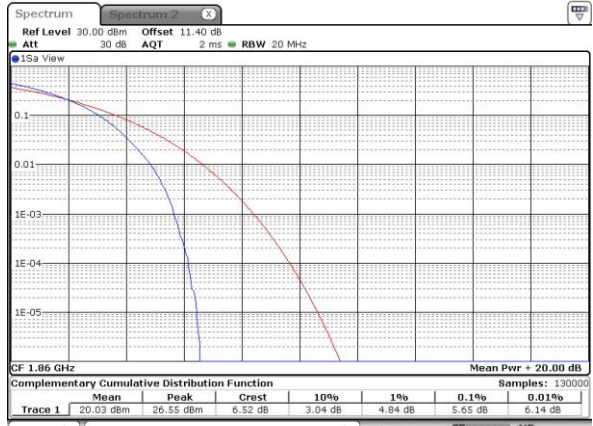

Date: 8 MAY 2017 23:47:09

Middle Channel / 1RB



Date: 8 MAY 2017 23:47:26

Middle Channel / Full RB

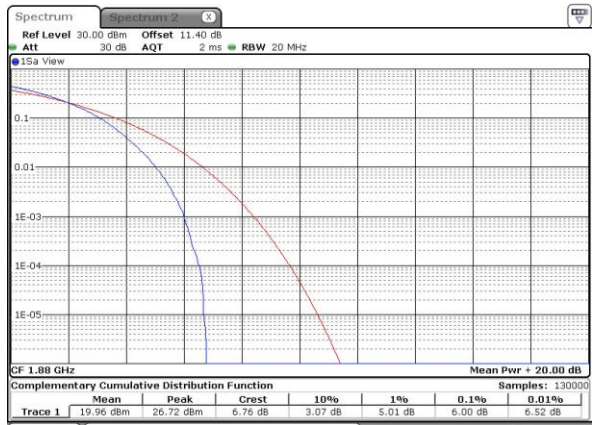

Date: 8 MAY 2017 23:47:39

Highest Channel / 1RB



Date: 8 MAY 2017 23:47:52

Highest Channel / Full RB

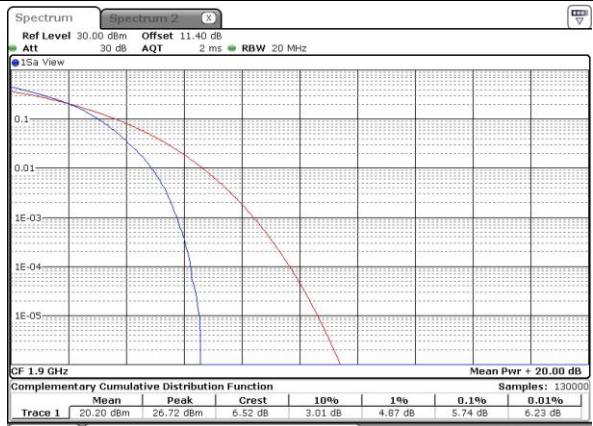

Date: 8 MAY 2017 23:48:07



LTE Band 2 / 20MHz / 64QAM

Lowest Channel / 1RB

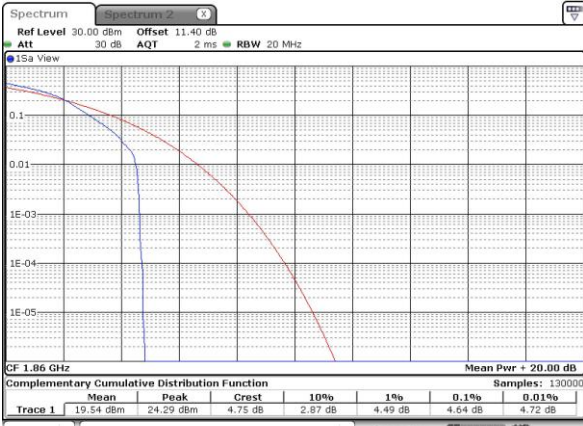

Date: 14.MAY.2017 09:05:59

Lowest Channel / Full RB

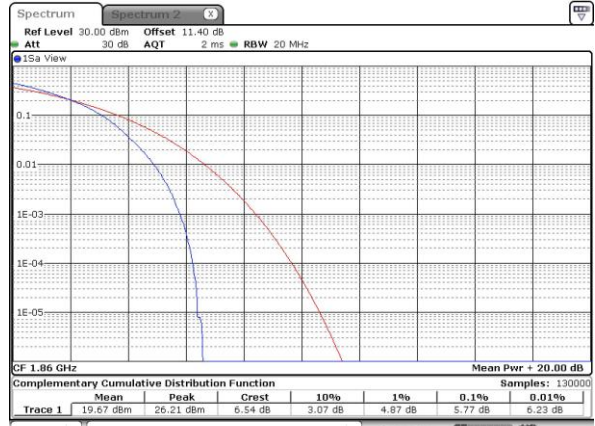

Date: 14.MAY.2017 09:06:10

Middle Channel / 1RB

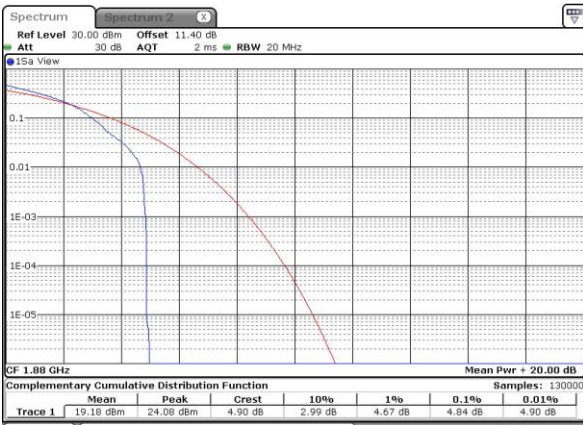

Date: 14.MAY.2017 09:06:21

Middle Channel / Full RB



Date: 14.MAY.2017 09:06:31

Highest Channel / 1RB

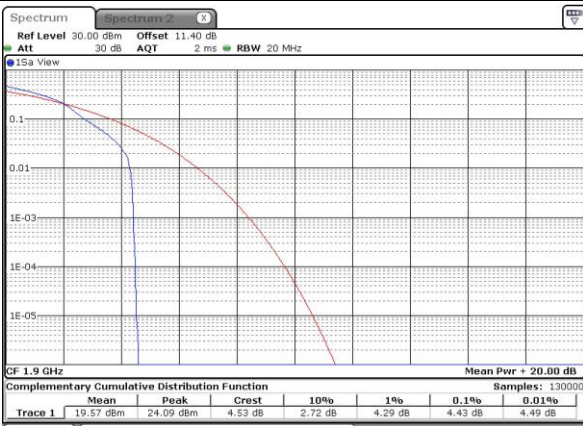

Date: 14.MAY.2017 09:06:41

Highest Channel / Full RB

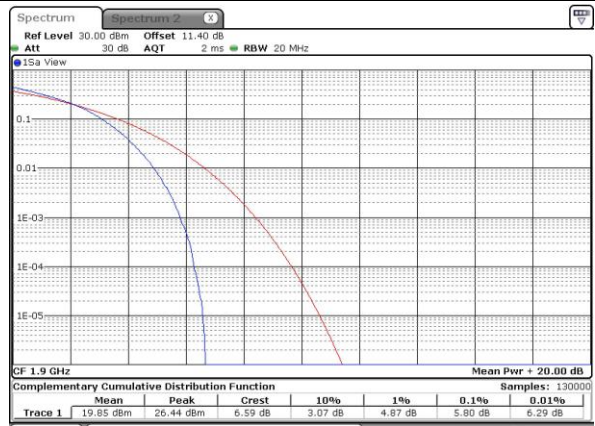

Date: 14.MAY.2017 09:06:50



26dB Bandwidth

Mode	LTE Band 2 : 26dB BW(MHz)											
BW	1.4MHz		3MHz		5MHz		10MHz		15MHz		20MHz	
Mod.	QPSK	16QAM	QPSK	16QAM	QPSK	16QAM	QPSK	16QAM	QPSK	16QAM	QPSK	16QAM
Lowest CH	1.23	1.22	3.04	3.00	4.89	4.93	9.79	9.71	14.21	14.66	20.10	20.18
Middle CH	1.22	1.23	3.02	3.04	4.87	4.97	9.75	9.69	14.36	14.42	20.18	20.10
Highest CH	1.23	1.22	2.96	3.07	4.93	4.87	9.79	9.83	14.36	14.24	20.22	20.38
BW	1.4MHz		3MHz		5MHz		10MHz		15MHz		20MHz	
Mod.	-	64QAM	-	64QAM	-	64QAM	-	64QAM	-	64QAM	-	64QAM
Lowest CH	-	1.23	-	3.05	-	4.88	-	9.65	-	14.42	-	20.14
Middle CH	-	1.22	-	2.93	-	4.81	-	9.75	-	14.39	-	20.30
Highest CH	-	1.23	-	3.06	-	4.91	-	9.83	-	14.42	-	20.26



LTE Band 2

Lowest Channel / 1.4MHz / QPSK

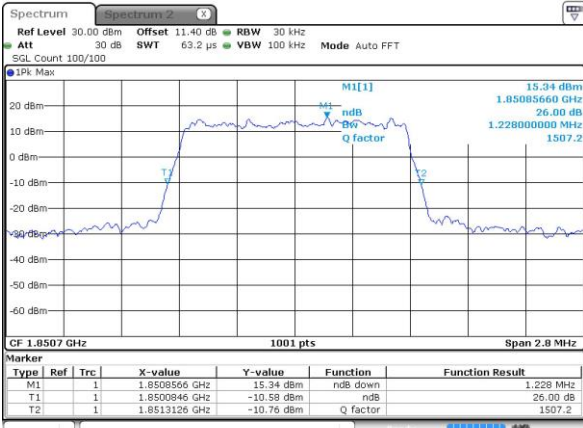

Date: 8 MAY 2017 23:29:10

Lowest Channel / 1.4MHz / 16QAM

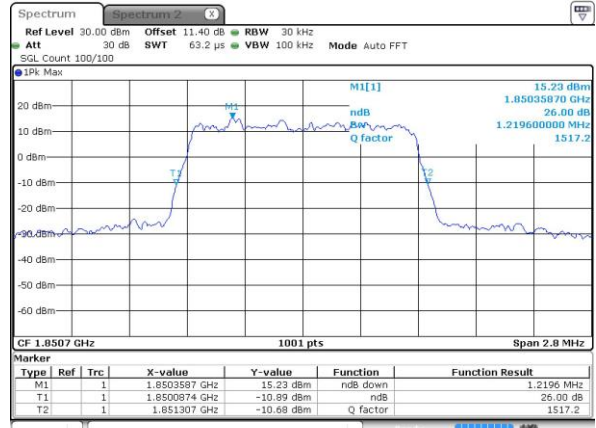

Date: 8 MAY 2017 23:29:20

Middle Channel / 1.4MHz / QPSK

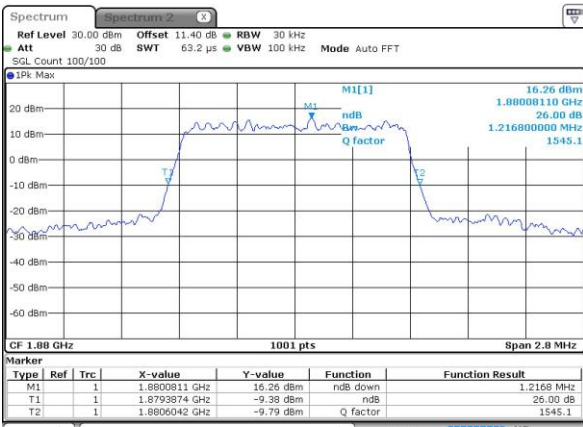

Date: 8 MAY 2017 23:36:17

Middle Channel / 1.4MHz / 16QAM

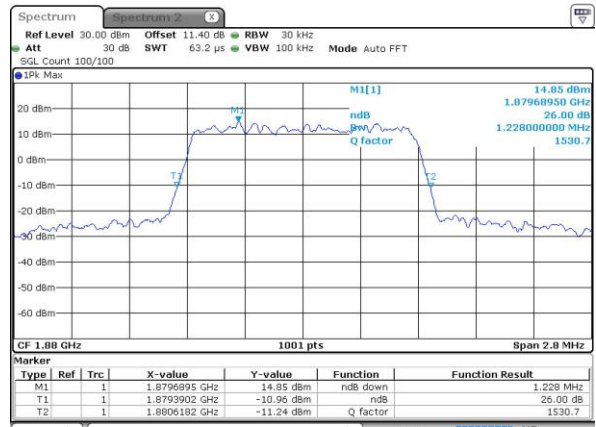

Date: 8 MAY 2017 23:36:27

Highest Channel / 1.4MHz / QPSK

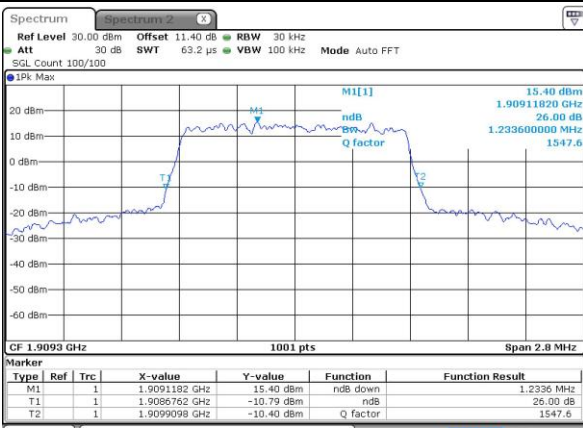

Date: 8 MAY 2017 23:38:48

Highest Channel / 1.4MHz / 16QAM

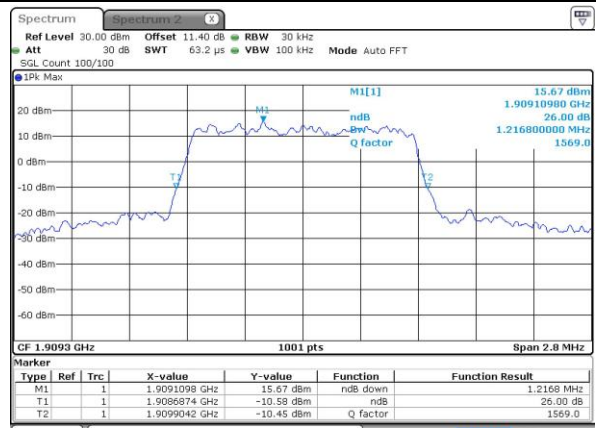

Date: 8 MAY 2017 23:38:58



LTE Band 2

Lowest Channel / 3MHz / QPSK

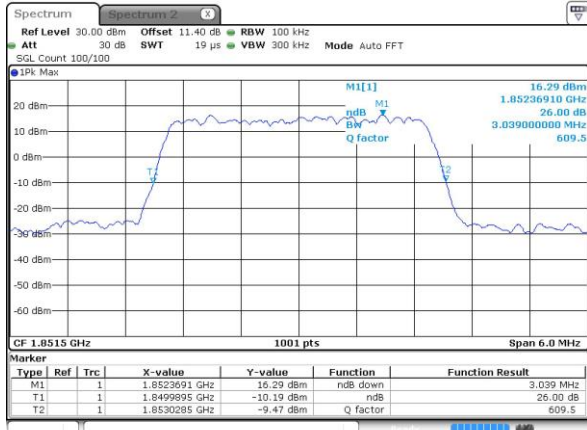

Date: 8 MAY 2017 22:01:50

Lowest Channel / 3MHz / 16QAM

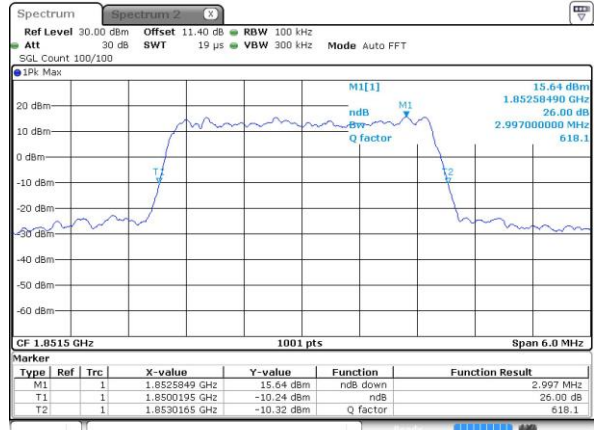

Date: 8 MAY 2017 22:02:01

Middle Channel / 3MHz / QPSK

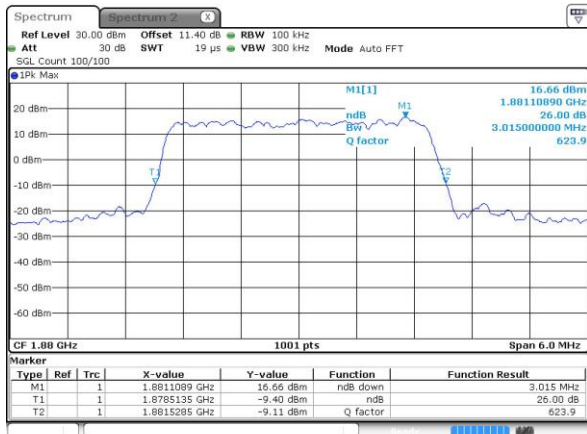

Date: 8 MAY 2017 22:08:57

Middle Channel / 3MHz / 16QAM

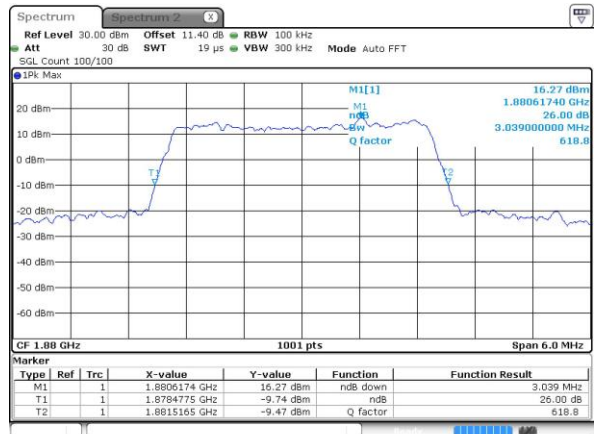

Date: 8 MAY 2017 22:08:06

Highest Channel / 3MHz / QPSK

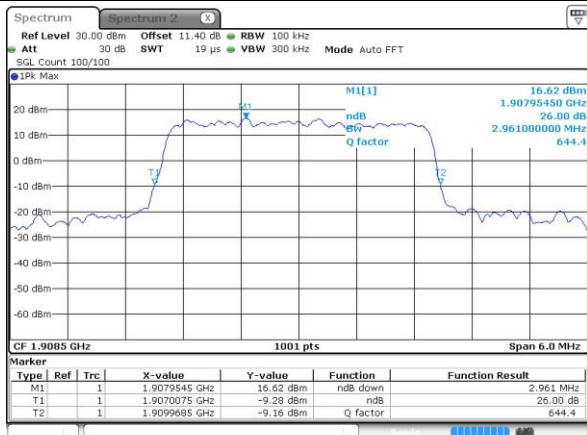

Date: 8 MAY 2017 22:11:28

Highest Channel / 3MHz / 16QAM

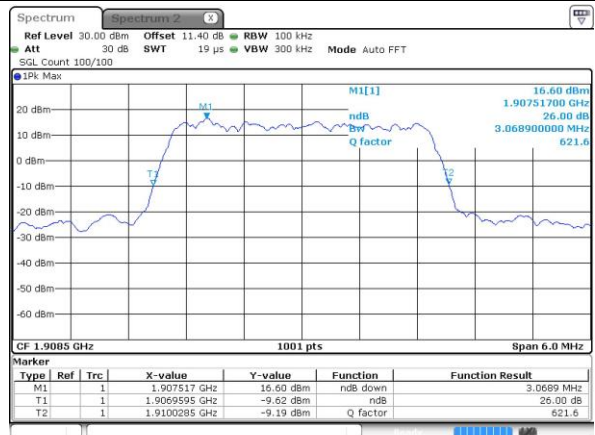

Date: 8 MAY 2017 22:11:38



LTE Band 2

Lowest Channel / 5MHz / QPSK

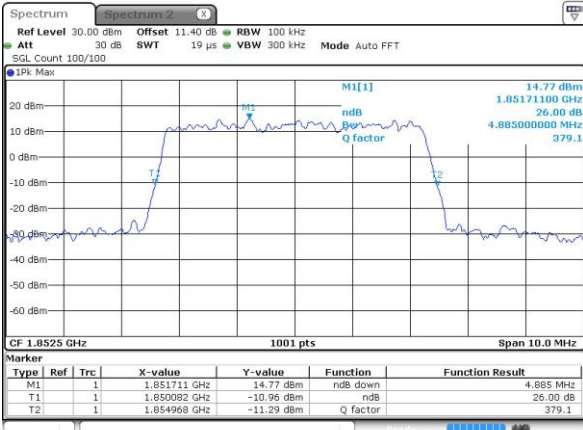

Date: 8 MAY 2017 22:18:35

Lowest Channel / 5MHz / 16QAM

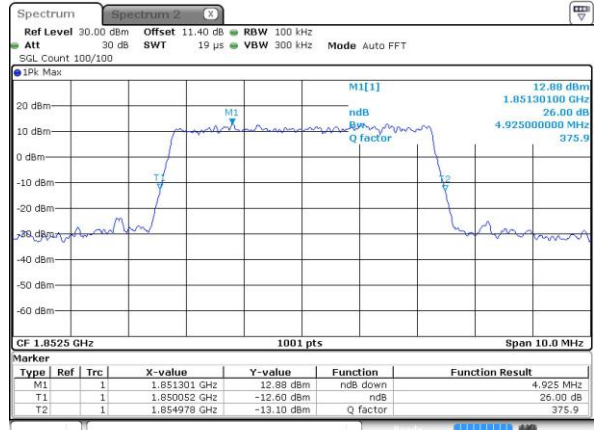

Date: 8 MAY 2017 22:18:46

Middle Channel / 5MHz / QPSK

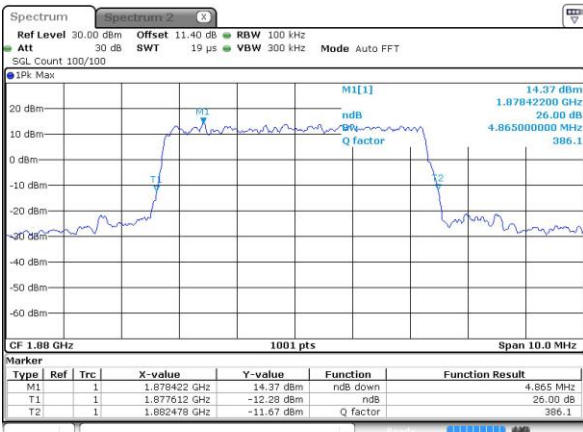

Date: 8 MAY 2017 22:25:42

Middle Channel / 5MHz / 16QAM

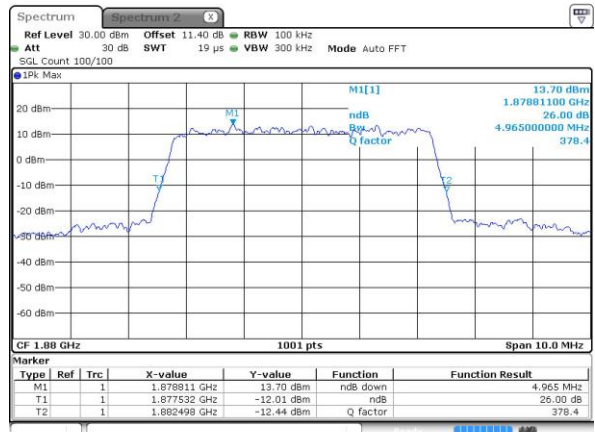

Date: 8 MAY 2017 22:25:53

Highest Channel / 5MHz / QPSK



Date: 8 MAY 2017 22:28:13

Highest Channel / 5MHz / 16QAM

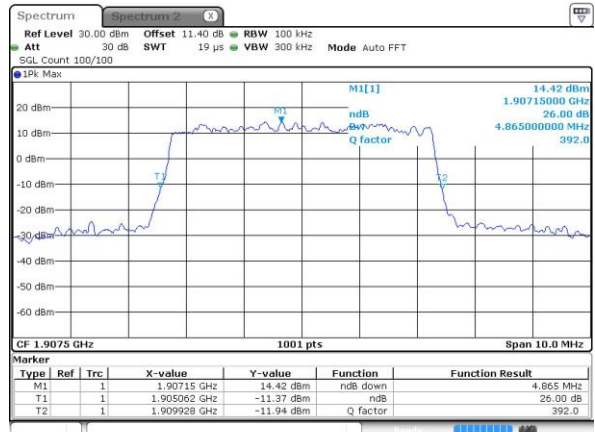

Date: 8 MAY 2017 22:28:23



LTE Band 2

Lowest Channel / 10MHz / QPSK

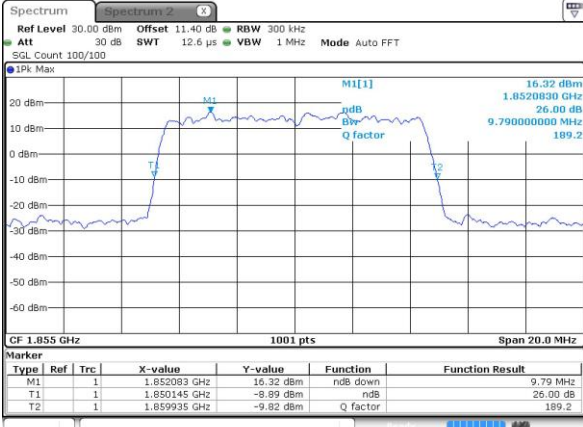

Date: 8 MAY 2017 22:35:20

Lowest Channel / 10MHz / 16QAM

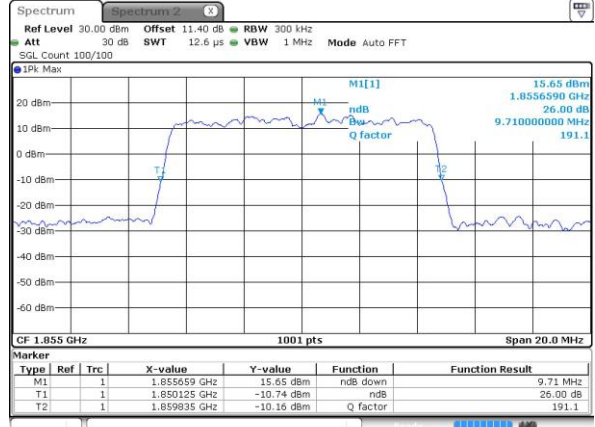

Date: 8 MAY 2017 22:35:30

Middle Channel / 10MHz / QPSK

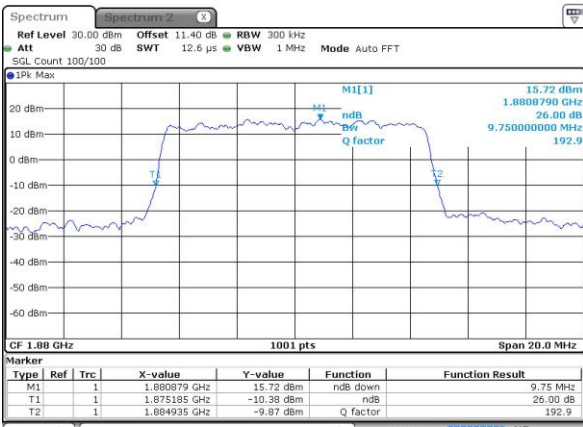

Date: 8 MAY 2017 22:42:27

Middle Channel / 10MHz / 16QAM

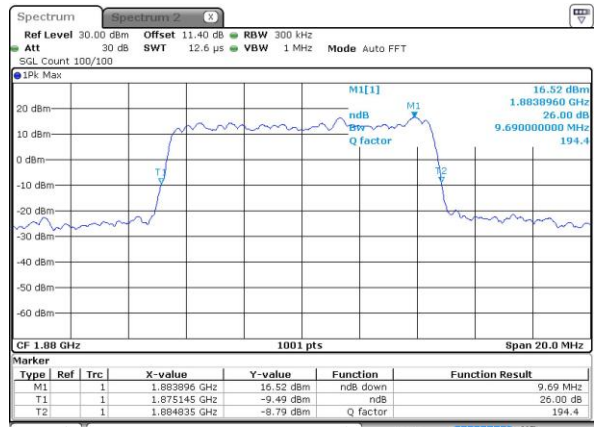

Date: 8 MAY 2017 22:42:38

Highest Channel / 10MHz / QPSK

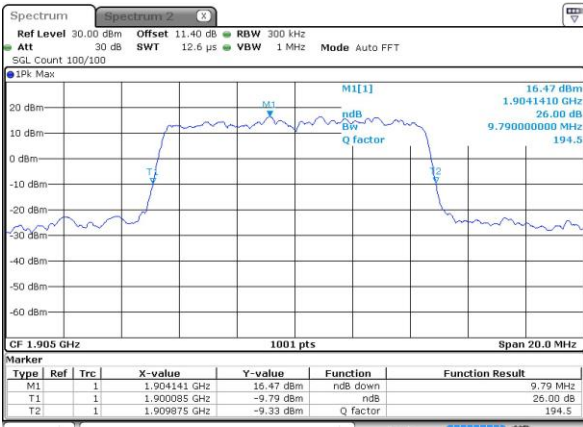

Date: 8 MAY 2017 22:44:58

Highest Channel / 10MHz / 16QAM

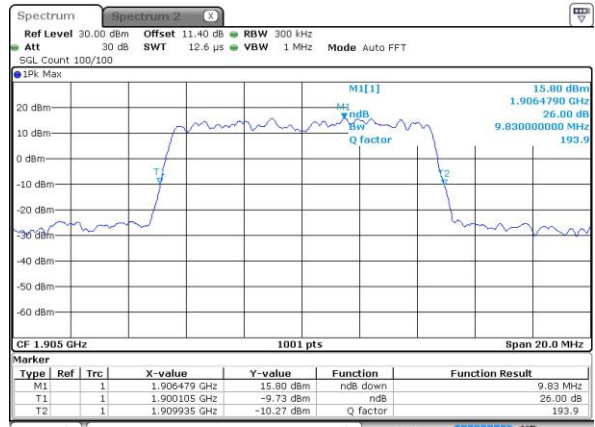

Date: 8 MAY 2017 22:45:08



LTE Band 2

Lowest Channel / 15MHz / QPSK

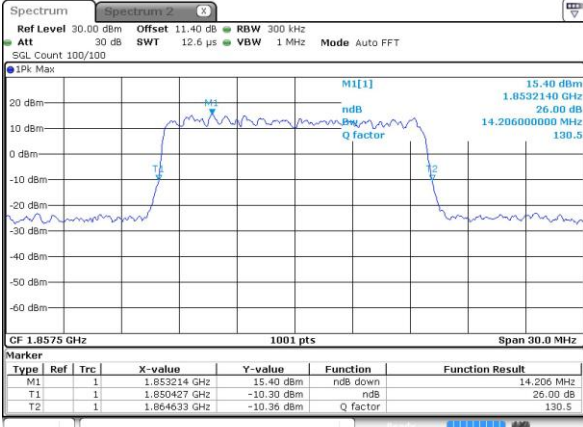

Date: 8 MAY 2017 22:52:05

Lowest Channel / 15MHz / 16QAM

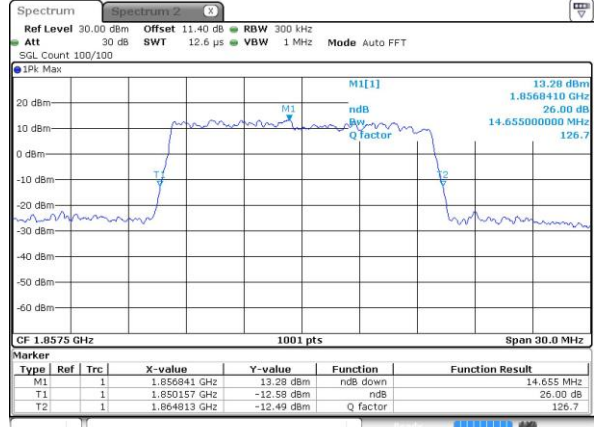

Date: 8 MAY 2017 22:52:15

Middle Channel / 15MHz / QPSK

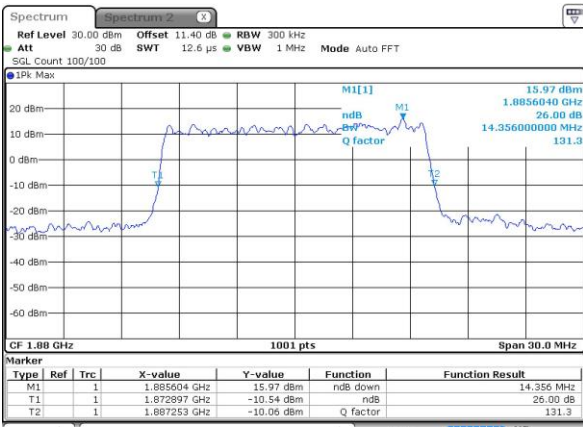

Date: 8 MAY 2017 22:59:12

Middle Channel / 15MHz / 16QAM

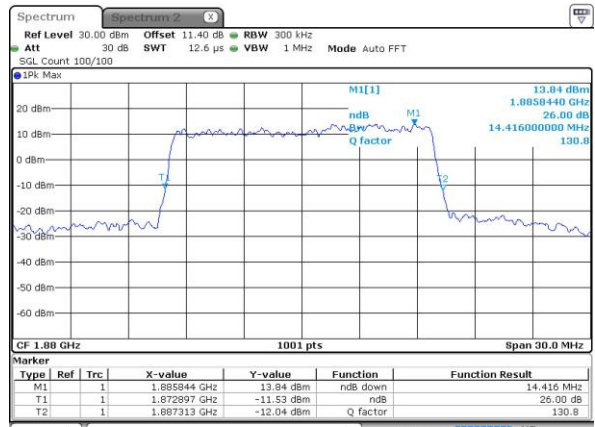

Date: 8 MAY 2017 22:59:22

Highest Channel / 15MHz / QPSK

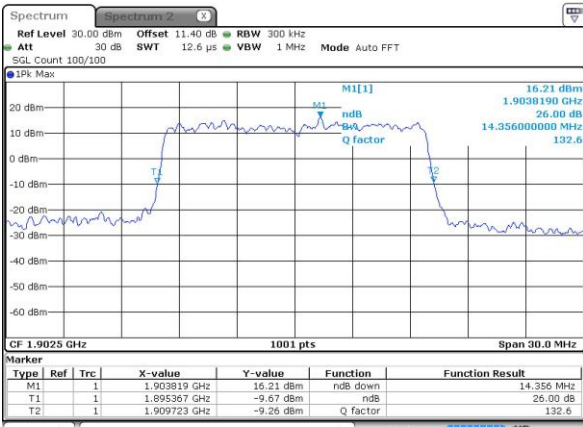

Date: 8 MAY 2017 23:01:43

Highest Channel / 15MHz / 16QAM

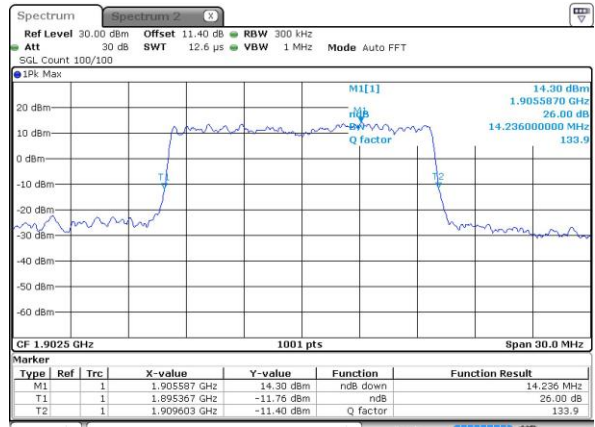

Date: 8 MAY 2017 23:01:53



LTE Band 2

Lowest Channel / 20MHz / QPSK

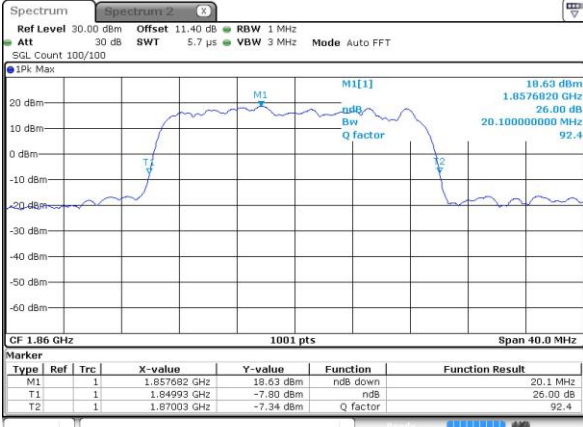

Date: 8 MAY 2017 23:08:50

Lowest Channel / 20MHz / 16QAM

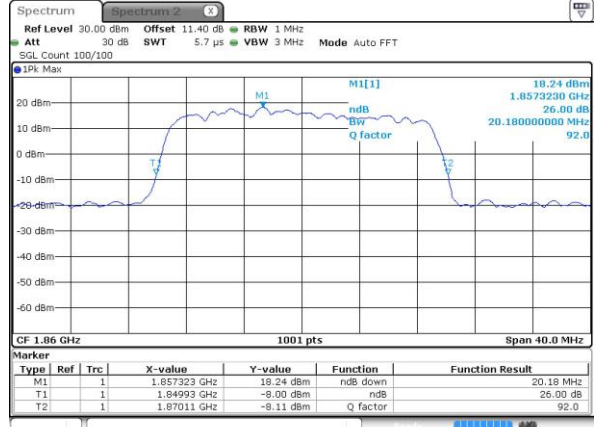

Date: 8 MAY 2017 23:09:00

Middle Channel / 20MHz / QPSK

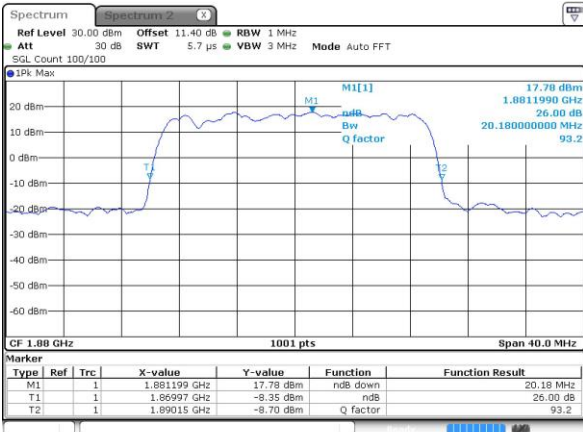

Date: 8 MAY 2017 23:15:57

Middle Channel / 20MHz / 16QAM

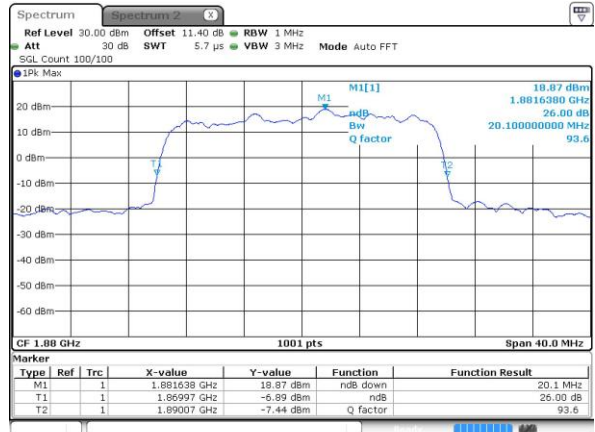

Date: 8 MAY 2017 23:16:07

Highest Channel / 20MHz / QPSK



Date: 8 MAY 2017 23:18:27

Highest Channel / 20MHz / 16QAM

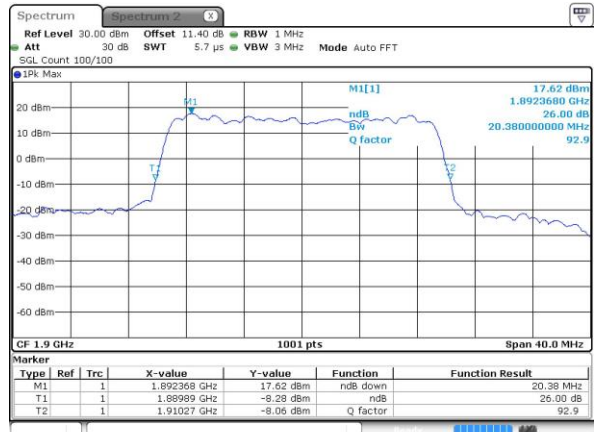

Date: 8 MAY 2017 23:18:38



LTE Band 2

Lowest Channel / 1.4MHz / 64QAM

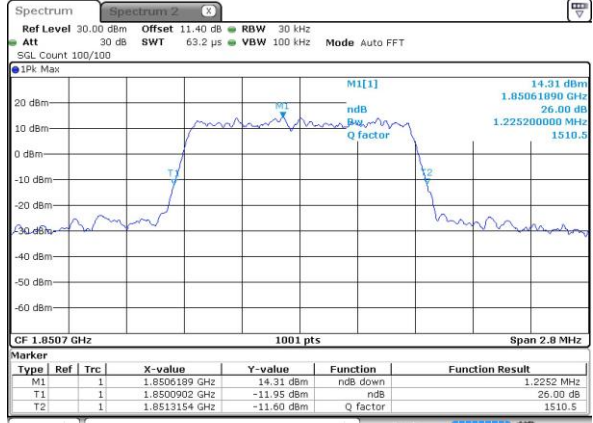

Date: 14.MAY.2017 08:58:18

Middle Channel / 1.4MHz / 64QAM

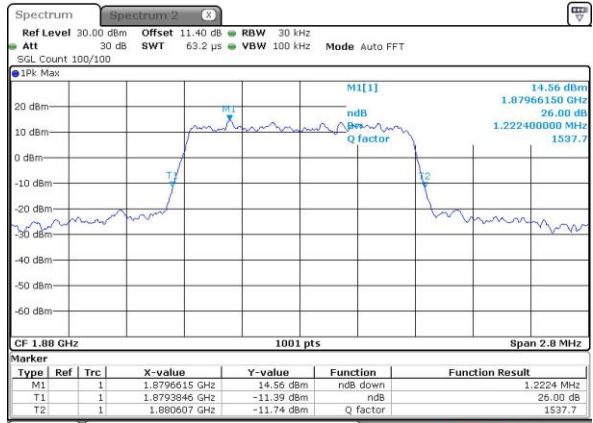

Date: 14.MAY.2017 08:59:52

Highest Channel / 1.4MHz / 64QAM

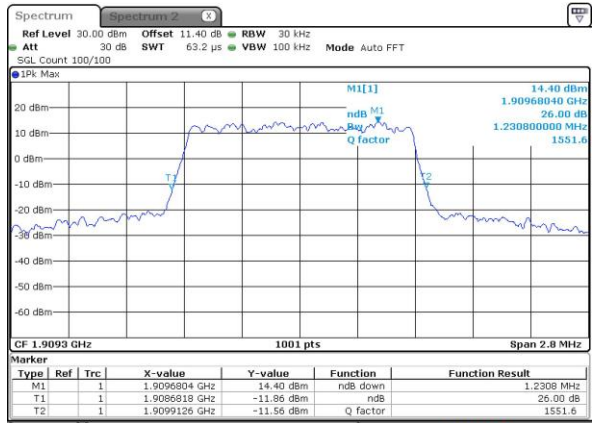

Date: 14.MAY.2017 09:01:07



LTE Band 2

Lowest Channel / 3MHz / 64QAM

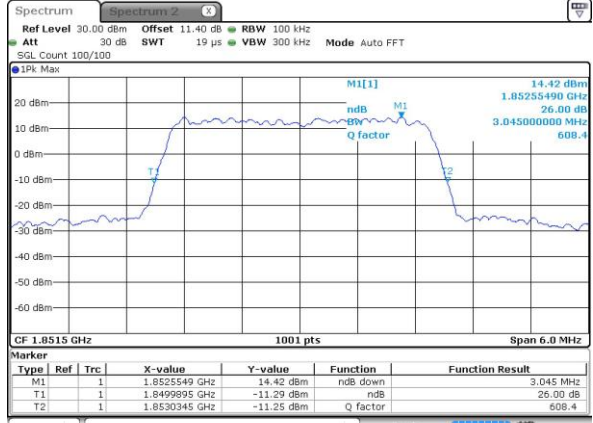

Date: 14.MAY.2017 08:12:59

Middle Channel / 3MHz / 64QAM

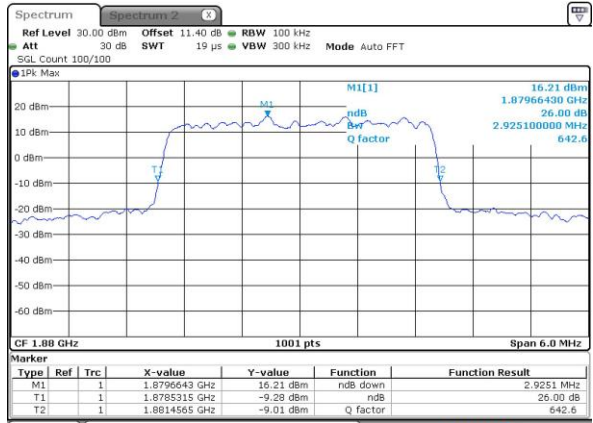

Date: 14.MAY.2017 08:16:33

Highest Channel / 3MHz / 64QAM

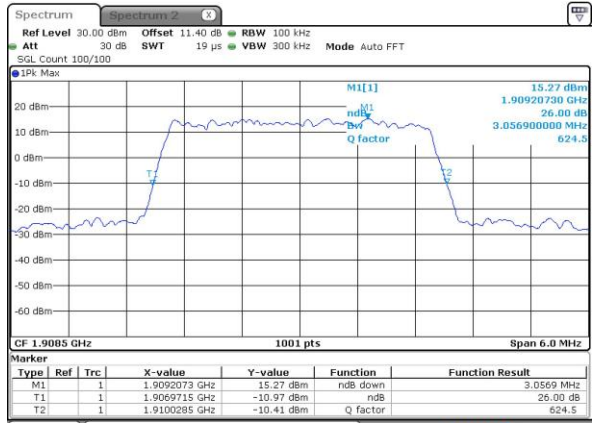

Date: 14.MAY.2017 08:17:48



LTE Band 2

Lowest Channel / 5MHz / 64QAM

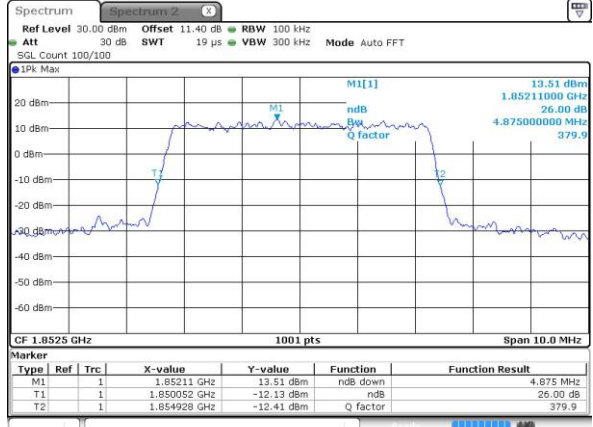

Date: 14.MAY.2017 08:21:22

Middle Channel / 5MHz / 64QAM

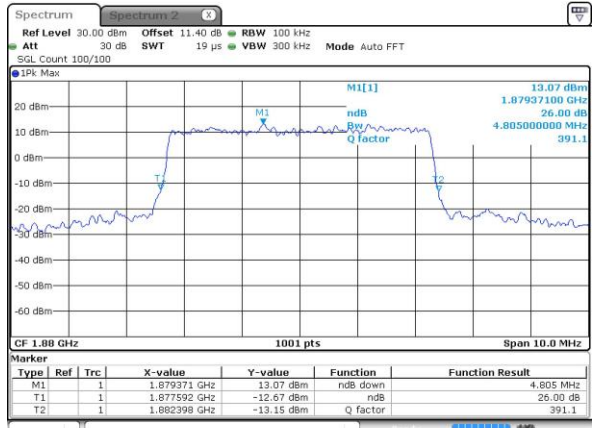

Date: 14.MAY.2017 08:24:55

Highest Channel / 5MHz / 64QAM

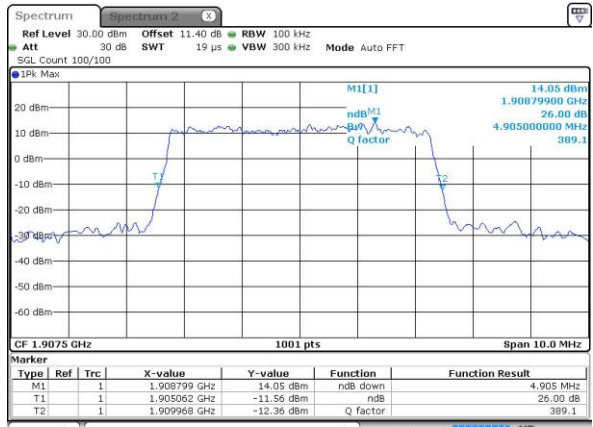

Date: 14.MAY.2017 08:28:11



LTE Band 2

Lowest Channel / 10MHz / 64QAM

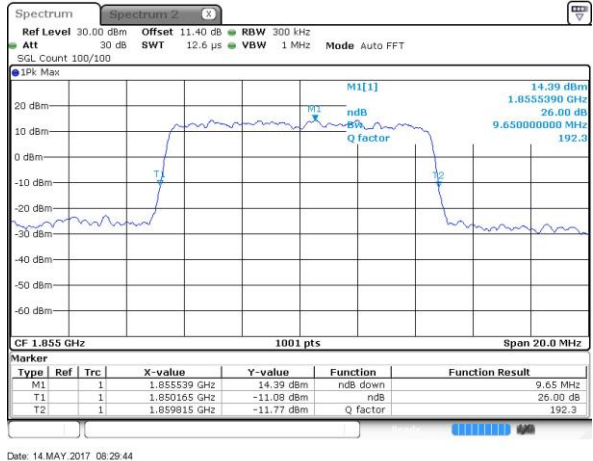

Date: 14.MAY.2017 08:29:44

Middle Channel / 10MHz / 64QAM

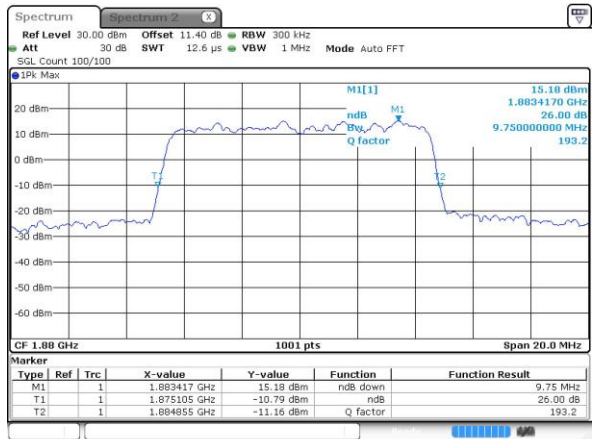

Date: 14.MAY.2017 08:33:18

Highest Channel / 10MHz / 64QAM



Date: 14.MAY.2017 08:34:33



LTE Band 2

Lowest Channel / 15MHz / 64QAM

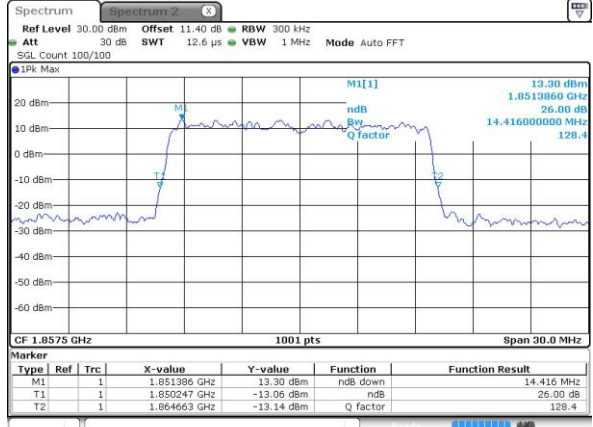

Middle Channel / 15MHz / 64QAM

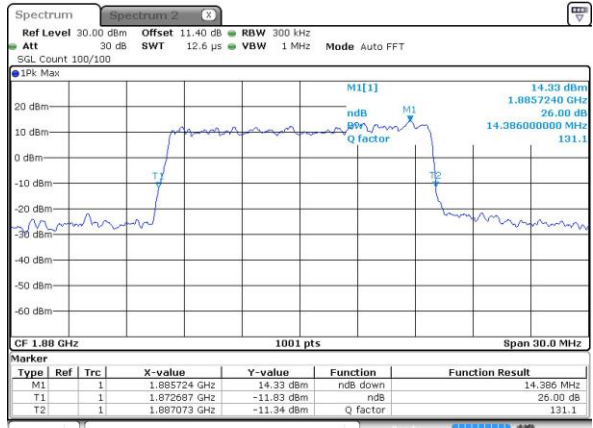

Highest Channel / 15MHz / 64QAM

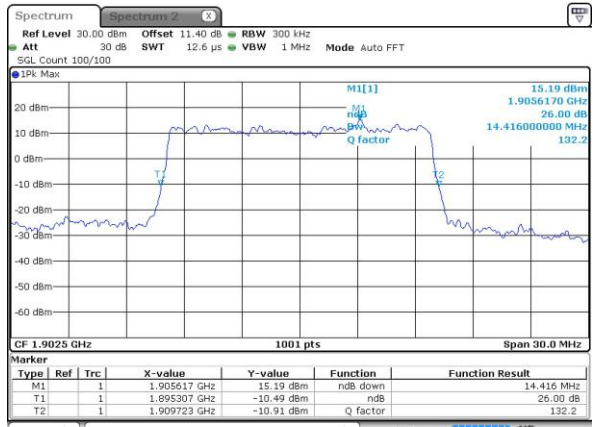



LTE Band 2

Lowest Channel / 20MHz / 64QAM

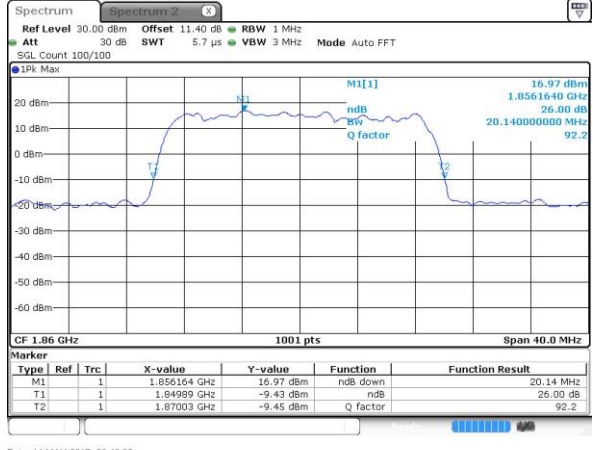

Date: 14.MAY.2017 08:46:30

Middle Channel / 20MHz / 64QAM

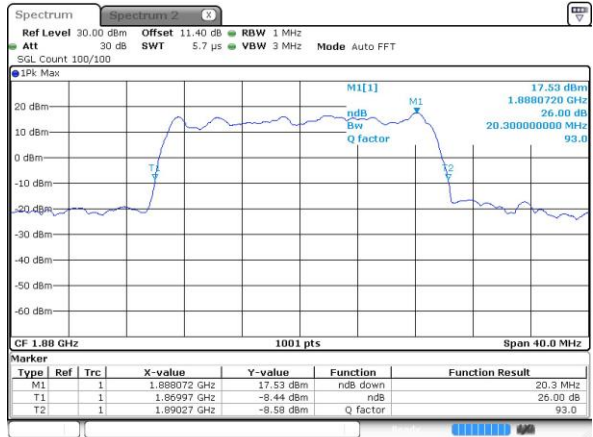

Date: 14.MAY.2017 08:50:03

Highest Channel / 20MHz / 64QAM

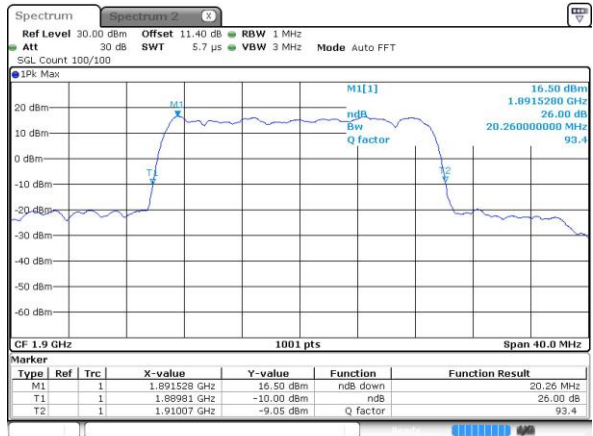

Date: 14.MAY.2017 08:51:19



Occupied Bandwidth

Mode	LTE Band 2 : 99%OBW(MHz)											
BW	1.4MHz		3MHz		5MHz		10MHz		15MHz		20MHz	
Mod.	QPSK	16QAM	QPSK	16QAM	QPSK	16QAM	QPSK	16QAM	QPSK	16QAM	QPSK	16QAM
Lowest CH	1.09	1.08	2.72	2.7	4.49	4.5	8.93	8.99	13.46	13.49	18.18	18.3
Middle CH	1.09	1.09	2.73	2.73	4.51	4.49	9.05	8.99	13.37	13.46	18.42	18.3
Highest CH	1.09	1.09	2.73	2.72	4.47	4.5	8.97	8.95	13.34	13.49	18.38	18.5
BW	1.4MHz		3MHz		5MHz		10MHz		15MHz		20MHz	
Mod.	-	64QAM	-	64QAM	-	64QAM	-	64QAM	-	64QAM	-	64QAM
Lowest CH	-	1.09	-	2.69	-	4.48	-	9.01	-	13.4	-	18.06
Middle CH	-	1.09	-	2.73	-	4.48	-	8.97	-	13.52	-	18.38
Highest CH	-	1.09	-	2.73	-	4.48	-	8.97	-	13.43	-	18.38



LTE Band 2

Lowest Channel / 1.4MHz / QPSK

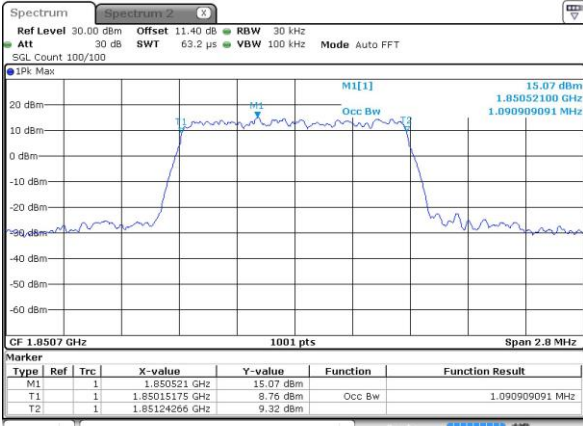

Lowest Channel / 1.4MHz / 16QAM

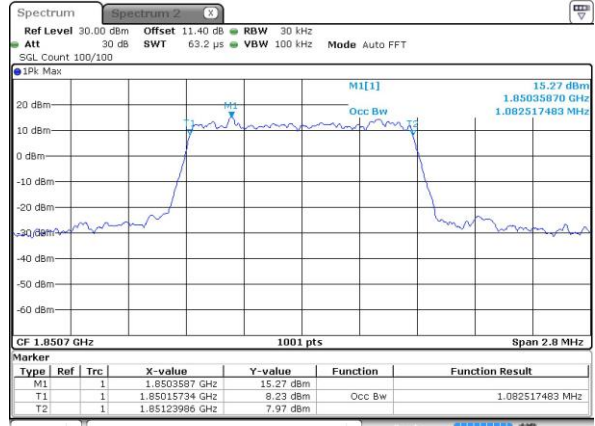

Middle Channel / 1.4MHz / QPSK

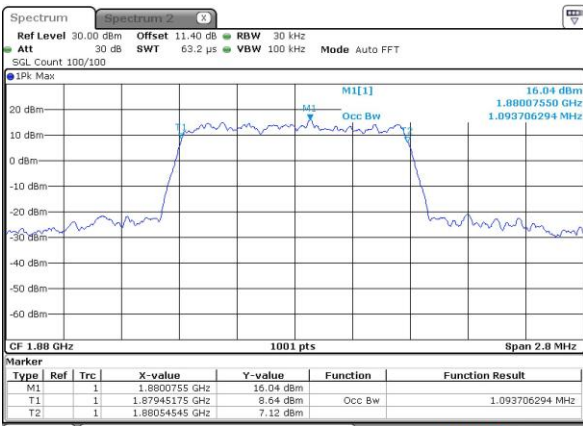

Middle Channel / 1.4MHz / 16QAM

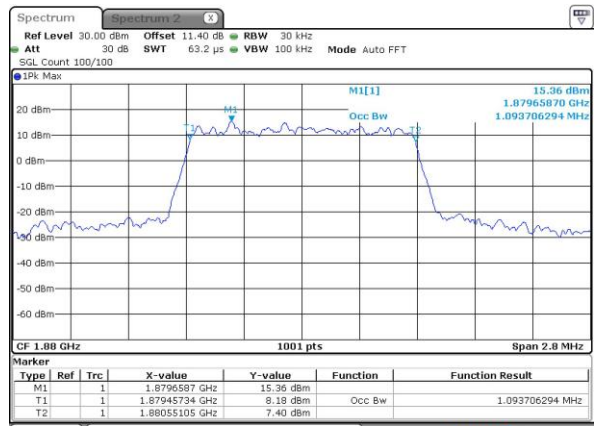

Highest Channel / 1.4MHz / QPSK

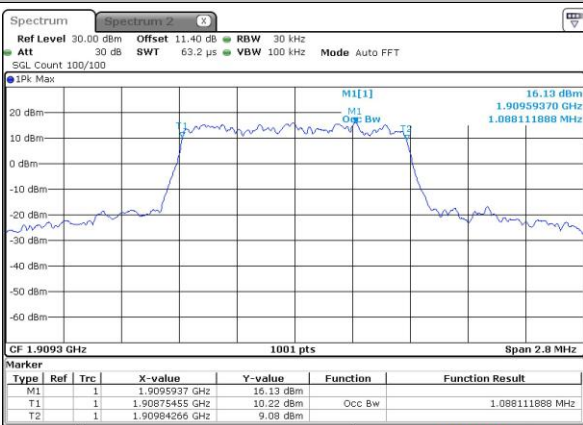

Highest Channel / 1.4MHz / 16QAM

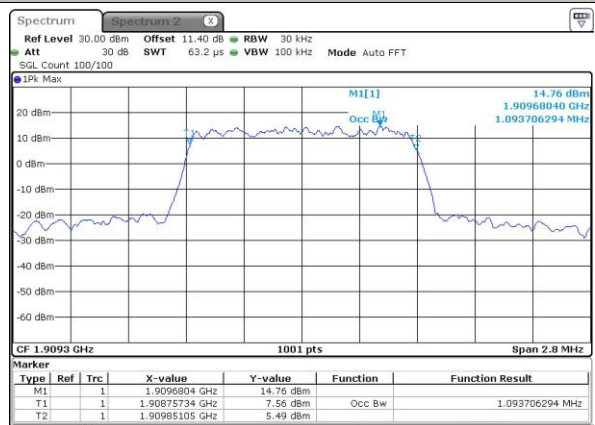



LTE Band 2

Lowest Channel / 3MHz / QPSK

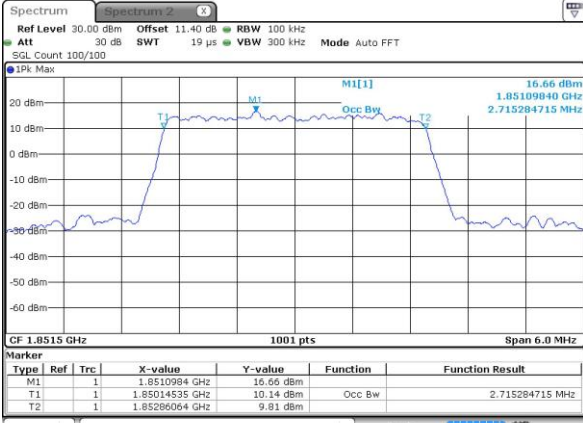

Date: 8 MAY 2017 22:01:29

Lowest Channel / 3MHz / 16QAM

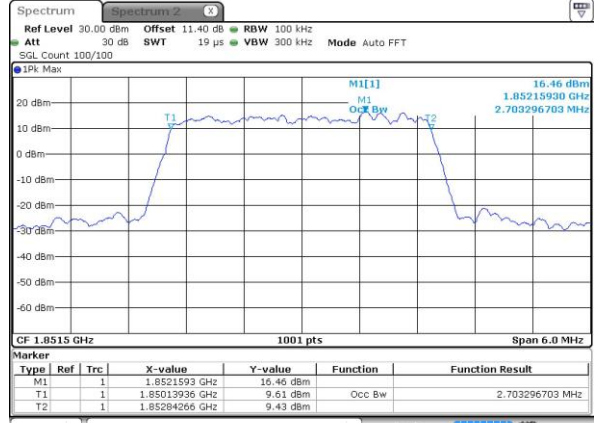

Date: 8 MAY 2017 22:01:40

Middle Channel / 3MHz / QPSK

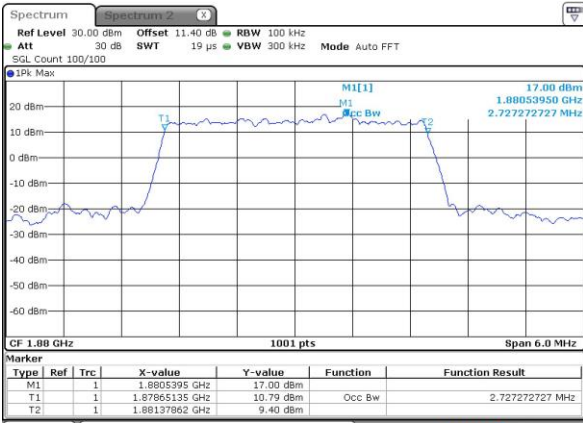

Date: 8 MAY 2017 22:08:37

Middle Channel / 3MHz / 16QAM

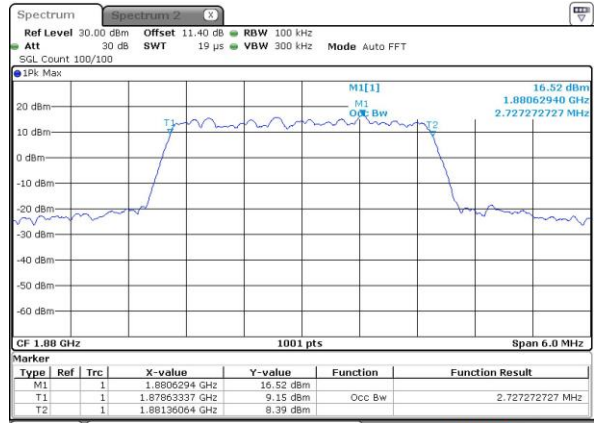

Date: 8 MAY 2017 22:08:47

Highest Channel / 3MHz / QPSK

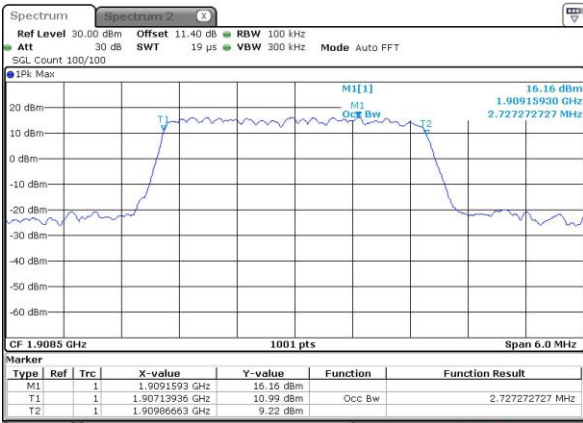

Date: 8 MAY 2017 22:11:07

Highest Channel / 3MHz / 16QAM

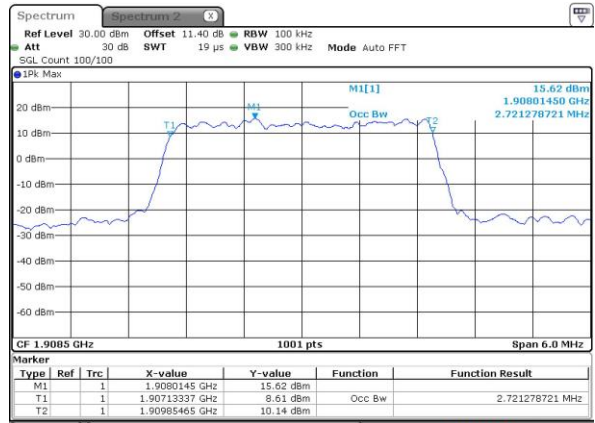

Date: 8 MAY 2017 22:11:18



LTE Band 2

Lowest Channel / 5MHz / QPSK

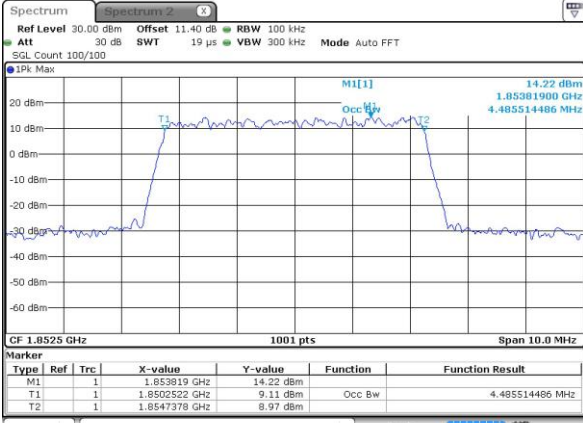

Date: 8 MAY 2017 22:18:14

Lowest Channel / 5MHz / 16QAM

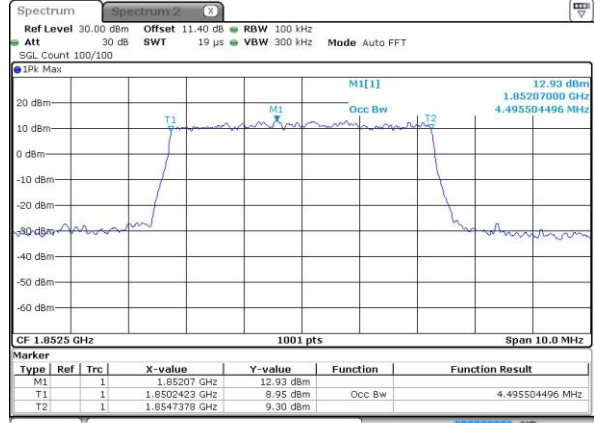

Date: 8 MAY 2017 22:18:25

Middle Channel / 5MHz / QPSK

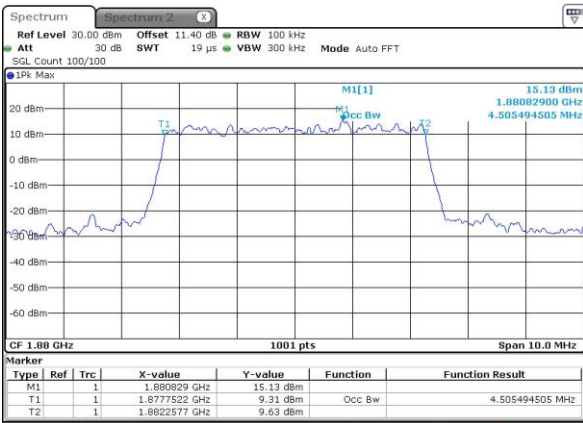

Date: 8 MAY 2017 22:25:22

Middle Channel / 5MHz / 16QAM

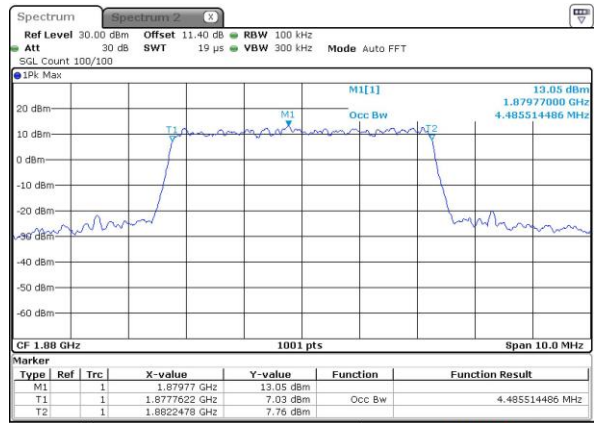

Date: 8 MAY 2017 22:25:32

Highest Channel / 5MHz / QPSK

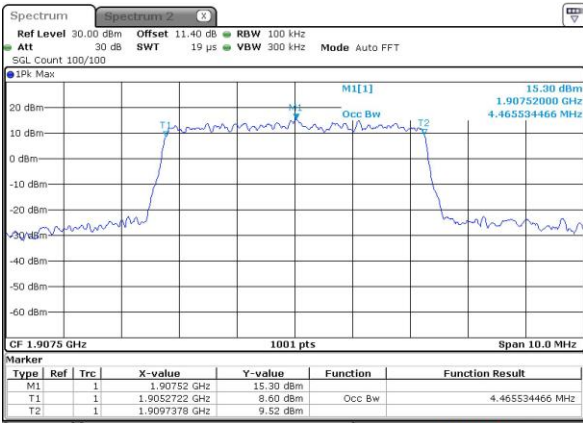

Date: 8 MAY 2017 22:27:52

Highest Channel / 5MHz / 16QAM

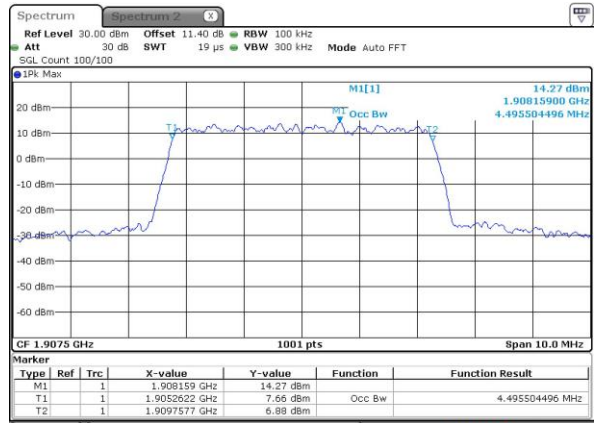

Date: 8 MAY 2017 22:28:03