



FCC RF Test Report

APPLICANT : Motorola Mobility, LLC
EQUIPMENT : Mobile Cellular Phone
BRAND NAME : Motorola
MODEL NAME : 5892
FCC ID : IHDT56VC1
STANDARD : FCC Part 15 Subpart E §15.407
CLASSIFICATION : (NII) Unlicensed National Information Infrastructure

The product was received on Jul. 25, 2016 and testing was completed on Jul. 29, 2016. We, SPORTON INTERNATIONAL INC., would like to declare that the tested sample has been evaluated in accordance with the test procedures and has been in compliance with the applicable technical standards.

The test results in this report apply exclusively to the tested model / sample. Without written approval of SPORTON INTERNATIONAL INC., the test report shall not be reproduced except in full.

Reviewed by: Joseph Lin / Supervisor

Approved by: Jones Tsai / Manager



SPORTON INTERNATIONAL INC.

No. 52, Hwa Ya 1st Rd., Hwa Ya Technology Park, Kwei-Shan District, Tao Yuan City, Taiwan, R.O.C.

SPORTON INTERNATIONAL INC.

TEL : 886-3-327-3456

FAX : 886-3-328-4978

FCC ID : IHDT56VC1

Page Number : 1 of 22

Report Issued Date : Aug. 04, 2016

Report Version : Rev. 01

Report Template No.: BU5-FR15EWLB4 Version 1.4



TABLE OF CONTENTS

REVISION HISTORY..... 3

SUMMARY OF TEST RESULT 4

1 GENERAL DESCRIPTION 5

 1.1 Applicant 5

 1.2 Manufacturer..... 5

 1.3 Product Feature of Equipment Under Test..... 5

 1.4 Product Specification of Equipment Under Test..... 6

 1.5 Modification of EUT 6

 1.6 Testing Location 6

 1.7 Applicable Standards..... 7

2 TEST CONFIGURATION OF EQUIPMENT UNDER TEST 8

 2.1 Carrier Frequency and Channel 8

 2.2 Test Mode..... 8

 2.3 Connection Diagram of Test System..... 9

 2.4 Support Unit used in test configuration and system 11

 2.5 EUT Operation Test Setup 11

3 TEST RESULT..... 12

 3.1 Unwanted Emissions Measurement..... 12

 3.2 AC Conducted Emission Measurement..... 17

4 LIST OF MEASURING EQUIPMENT 21

5 UNCERTAINTY OF EVALUATION..... 22

APPENDIX A. RADIATED SPURIOUS EMISSION

APPENDIX B. RADIATED SPURIOUS EMISSION PLOTS

APPENDIX C. DUTY CYCLE PLOTS

APPENDIX D. ORIGINAL REPORT



SUMMARY OF TEST RESULT

Report Section	FCC Rule	Description	Limit	Result	Remark
3.1	15.407(b)	Unwanted Emissions	15.407(b)(4)(i) & 15.209(a)	Pass	Under limit 7.97 dB at 40.800 MHz
3.2	15.207	AC Conducted Emission	15.207(a)	Pass	Under limit 1.40 dB at 0.270 MHz



1 General Description

1.1 Applicant

Motorola Mobility, LLC

222 W Merchandise Mart Plaza, Suite 1800, Chicago, IL 60654, United States

1.2 Manufacturer

Motorola Mobility, LLC

222 W Merchandise Mart Plaza, Suite 1800, Chicago, IL 60654, United States

1.3 Product Feature of Equipment Under Test

Product Feature	
Equipment	Mobile Cellular Phone
Brand Name	Motorola
Model Name	5892
FCC ID	IHDT56VC1
IMEI Code	354130070011751 (for Radiation) 354130070011991 (for Conduction)
EUT supports Radios application	CDMA/EV-DO/GSM/EGPRS/WCDMA/HSPA/LTE/NFC WLAN 11b/g/n HT20 WLAN 11a/n HT20/HT40 Bluetooth v3.0 EDR Bluetooth v4.0 LE
HW Version	DVT2
EUT Stage	Identical Prototype

Remark: The above EUT's information was declared by manufacturer. Please refer to the specifications or user's manual for more detailed description.

Accessory List	
WPC Cover	Brand Name : INCIPIO
	Model Name : MT-043-CASE



1.4 Product Specification of Equipment Under Test

Standards-related Product Specification		
Tx/Rx Channel Frequency Range	5745 MHz ~ 5825 MHz	
Type of Modulation	802.11a/n : OFDM (BPSK / QPSK / 16QAM / 64QAM)	
Antenna Type	ILA Antenna (The antenna peak gain of EUT is less than 6 dBi)	
Antenna Function Description		
	802.11 a/n MIMO	Ant.1 V
		Ant.2 V

1.5 Modification of EUT

No modifications are made to the EUT during all test items.

1.6 Testing Location

Sporton Lab is accredited to ISO 17025 by Taiwan Accreditation Foundation (TAF code : 1190) and the FCC designation No. TW1022 under the FCC 2.948(e) by Mutual Recognition Agreement (MRA) in FCC Test.

Test Site	SPORTON INTERNATIONAL INC.
Test Site Location	No. 52, Hwa Ya 1 st Rd., Hwa Ya Technology Park, Kwei-Shan District, Tao Yuan City, Taiwan, R.O.C. TEL: +886-3-327-3456 FAX: +886-3-328-4978
Test Site No.	Sporton Site No.
	CO05-HY

Note: The test site complies with ANSI C63.4 2014 requirement.

Test Site	SPORTON INTERNATIONAL INC.
Test Site Location	No.58, Aly. 75, Ln. 564, Wenhua 3rd Rd. Guishan Dist, Taoyuan City, Taiwan (R.O.C.) TEL: +886-3-327-0868 FAX: +886-3-327-0855
Test Site No.	Sporton Site No.
	03CH11-HY

Note: The test site complies with ANSI C63.4 2014 requirement.



1.7 Applicable Standards

According to the specifications of the manufacturer, the EUT must comply with the requirements of the following standards:

- ♦ FCC Part 15 Subpart E
- ♦ FCC KDB 789033 D02 General UNII Test Procedures New Rules v01r02
- ♦ FCC KDB 662911 D01 Multiple Transmitter Output v02r01.
- ♦ KDB 648474 D03 Handset Wireless Chargers Battery Covers v01r04
- ♦ ANSI C63.10-2013

Remark:

1. All test items were verified and recorded according to the standards and without any deviation during the test.
2. This EUT has also been tested and complied with the requirements of FCC Part 15, Subpart B, recorded in a separate test report.



2 Test Configuration of Equipment Under Test

The EUT has been associated with peripherals and configuration operated in a manner tended to maximize its emission characteristics in a typical application. Frequency range investigated: conducted emission (150 kHz to 30 MHz) and radiated emission (9 kHz to the 10th harmonic of the highest fundamental frequency or to 40 GHz, whichever is lower).

2.1 Carrier Frequency and Channel

Frequency Band	Channel	Freq. (MHz)	Channel	Freq. (MHz)
5725-5850 MHz Band 4 (U-NII-3)	149	5745	159	5795
	151	5755	161	5805
	153	5765	165	5825
	157	5785		

Note: The above Frequency and Channel in boldface were 802.11n HT40.

2.2 Test Mode

Final test mode of conducted test items and radiated spurious emissions are considering the modulation and worse data rates as below table.

Modulation	Data Rate
802.11n HT40	MCS0

AC Conducted Emission	Mode 1 : GSM1900 Idle + Bluetooth Link + WLAN (5GHz) Link + Camera + WPC Back Cover + WPC Charging Pad + USB Cable (Charging from Adapter) Mode 2 : WCDMA Band V Idle + Bluetooth Link + WLAN (5GHz) Link + MPEG4 + WPC Back Cover + PMA Charging Pad + Adapter
--------------------------------------	--

Ch. #		Band IV : 5725-5850 MHz	
		802.11n HT40	
L	Low	-	
M	Middle	-	
H	High	159	

2.3 Connection Diagram of Test System

<WLAN Tx with PMA Charging Mode>

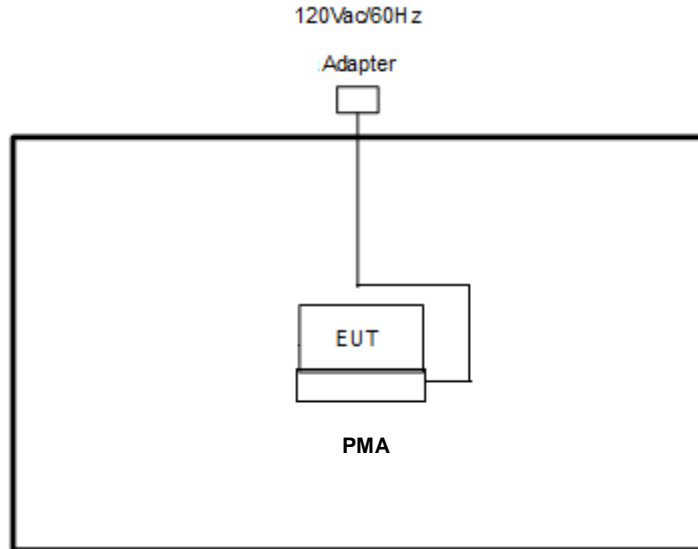

<AC Conducted Emission with WPC Charging Mode>

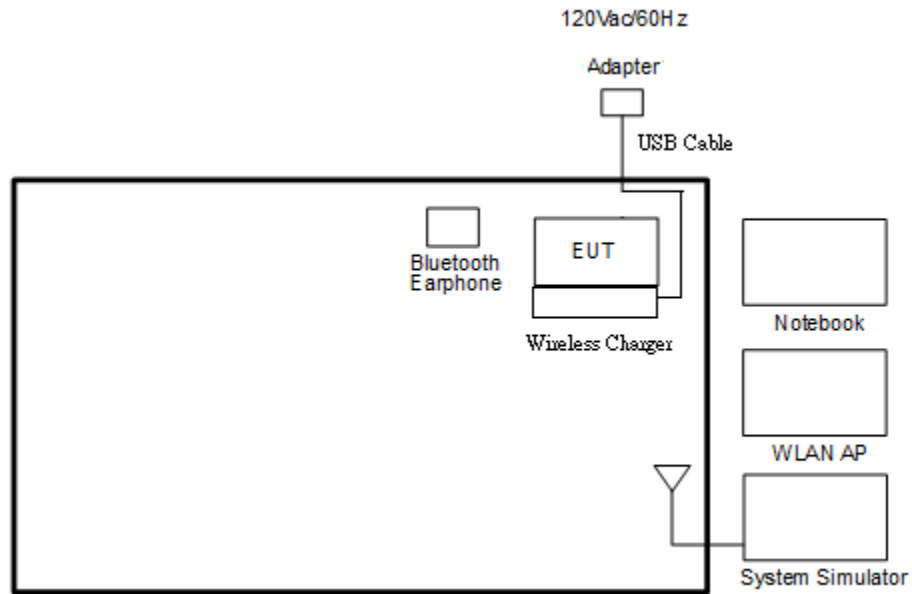

<AC Conducted Emission with PMA Charging Mode>

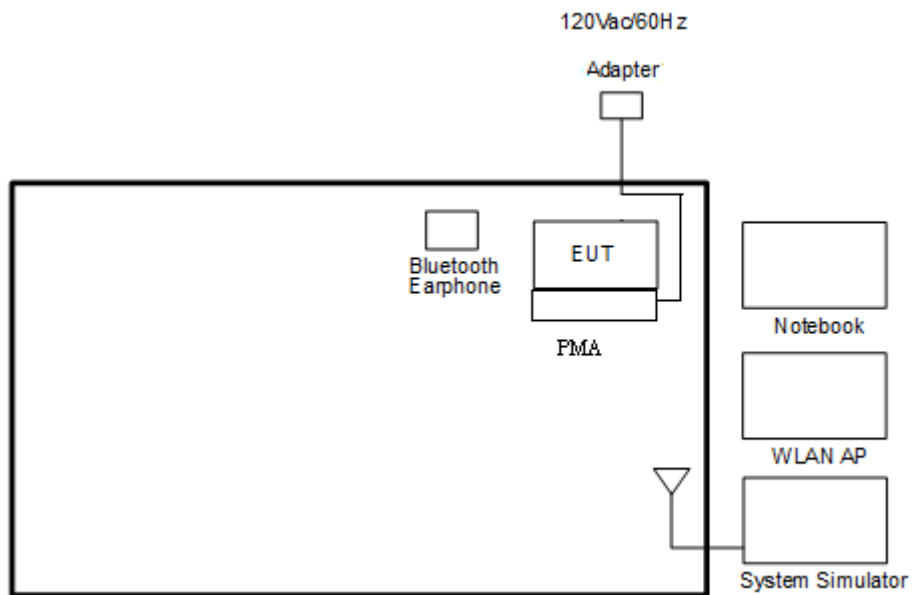



2.4 Support Unit used in test configuration and system

Item	Equipment	Trade Name	Model Name	FCC ID	Data Cable	Power Cord
1.	System Simulator	Anritsu	MT8820C	N/A	N/A	Unshielded, 1.8 m
2.	WLAN AP	D-Link	DIR-628	KA2DIR628A2	N/A	Unshielded, 1.8 m
3.	Bluetooth Earphone	Sony Ericsson	MW600	PY7DDA-2029	N/A	N/A
4.	Notebook	DELL	Latitude E6320	FCC DoC/ Contains FCC ID: QDS-BRCM1054	N/A	AC I/P: Unshielded, 1.2 m DC O/P: Shielded, 1.8 m
5.	SD Card	SanDisk	MicroSD HC	FCC DoC	N/A	N/A
6.	Wireless Charger	LG	WCD-100	FCC DoC	N/A	N/A
7.	PMA	DURACELL	M-018B-518A	FCC DoC	N/A	N/A
8.	USB Cable	Motorola	SKN6461A	N/A	Unshielded, 1.0 m	N/A
9.	Adapter	Motorola	SPN5865A	N/A	N/A	N/A

2.5 EUT Operation Test Setup

For WLAN function, programmed RF utility, "QRCT" installed in the notebook make the EUT provide functions like channel selection and power level for continuous transmitting and receiving signals.



3 Test Result

3.1 Unwanted Emissions Measurement

This section as specified in FCC Part 15.407(b) is to measure unwanted emissions through radiated measurement for band edge spurious emissions and out of band emissions measurement. The unwanted emissions shall comply with 15.407(b)(1) to (6), and restricted bands per FCC Part15.205.

3.1.1 Limit of Unwanted Emissions

- (1) For transmitters operating in the 5.725-5.85 GHz band:
 15.407(b)(4)(i) All emissions shall be limited to a level of -27 dBm/MHz at 75 MHz or more above or below the band edge increasing linearly to 10 dBm/MHz at 25 MHz above or below the band edge, and from 25 MHz above or below the band edge increasing linearly to a level of 15.6 dBm/MHz at 5 MHz above or below the band edge, and from 5 MHz above or below the band edge increasing linearly to a level of 27 dBm/MHz at the band edge..
- (2) Unwanted spurious emissions fallen in restricted bands per FCC Part15.205 shall comply with the general field strength limits set forth in § 15.209 as below table,

Frequency (MHz)	Field Strength (microvolts/meter)	Measurement Distance (meters)
0.009 – 0.490	2400/F(kHz)	300
0.490 – 1.705	24000/F(kHz)	30
1.705 – 30.0	30	30
30 – 88	100	3
88 – 216	150	3
216 - 960	200	3
Above 960	500	3

Note: The following formula is used to convert the EIRP to field strength.

$$E = \frac{1000000\sqrt{30P}}{3} \text{ } \mu\text{V/m, where P is the eirp (Watts)}$$

EIRP (dBm)	Field Strength at 3m (dBµV/m)
-17	78.3
- 27	68.3

- (3) KDB 789033 D02 General UNII Test Procedures New Rules v01r02 G)2)c) As specified in 15.407(b), emissions above 1000 MHz that are outside of the restricted bands are subject to a peak emission limit of -27 dBm/MHz (or -17 dBm/MHz as specified in 15.407(b)(4)). However, an out-of-band emission that complies with both the average and peak limits of 15.209 is not required to satisfy the -27 dBm/MHz or -17 dBm/MHz peak emission limit.



3.1.2 Measuring Instruments

The measuring equipment is listed in the section 4 of this test report.

3.1.3 Test Procedures

1. The testing follows FCC KDB 789033 D02 General UNII Test Procedures New Rules v01r02. Section G) Unwanted emissions measurement.

(1) Procedure for Unwanted Emissions Measurements Below 1000MHz

- RBW = 120 kHz
- VBW = 300 kHz
- Detector = Peak
- Trace mode = max hold

(2) Procedure for Peak Unwanted Emissions Measurements Above 1000 MHz

- RBW = 1 MHz
- VBW \geq 3 MHz
- Detector = Peak
- Sweep time = auto
- Trace mode = max hold

(3) Procedures for Average Unwanted Emissions Measurements Above 1000MHz

- RBW = 1 MHz
- VBW = 10 Hz, when duty cycle is no less than 98 percent.
- VBW \geq 1/T, when duty cycle is less than 98 percent where T is the minimum transmission duration over which the transmitter is on and is transmitting at its maximum power control level for the tested mode of operation.

2. The EUT was placed on a turntable with 0.8 meter for frequency below 1GHz and 1.5 meter for frequency above 1GHz respectively above ground.
3. The EUT was set 3 meters from the interference receiving antenna which was mounted on the top of a variable height antenna tower.
4. The antenna is a broadband antenna and its height is adjusted between one meter and four meters above ground to find the maximum value of the field strength for both horizontal polarization and vertical polarization of the antenna.
5. For each suspected emission, the EUT was arranged to its worst case and then adjust the antenna tower (from 1 m to 4 m) and turntable (from 0 degree to 360 degrees) to find the maximum reading.
6. For testing below 1GHz, if the emission level of the EUT in peak mode was 3 dB lower than the limit specified, then peak values of EUT will be reported, otherwise, the emissions will be repeated one by one using the CISPR quasi-peak method and reported.
7. For testing above 1GHz, the emission level of the EUT in peak mode was 20dB lower than average limit (that means the emission level in average mode also complies with the limit in average mode), then peak values of EUT will be reported, otherwise, the emissions will be measured in average mode again and reported.

3.1.4 Test Setup

For radiated emissions below 30MHz

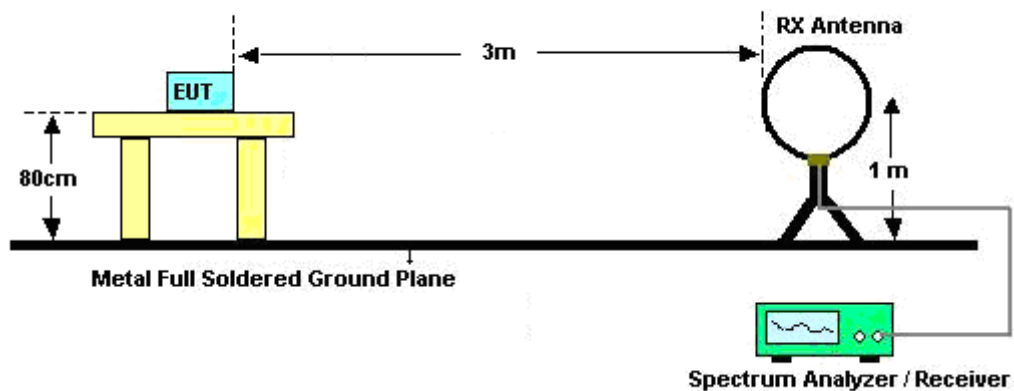

For radiated emissions from 30MHz to 1GHz

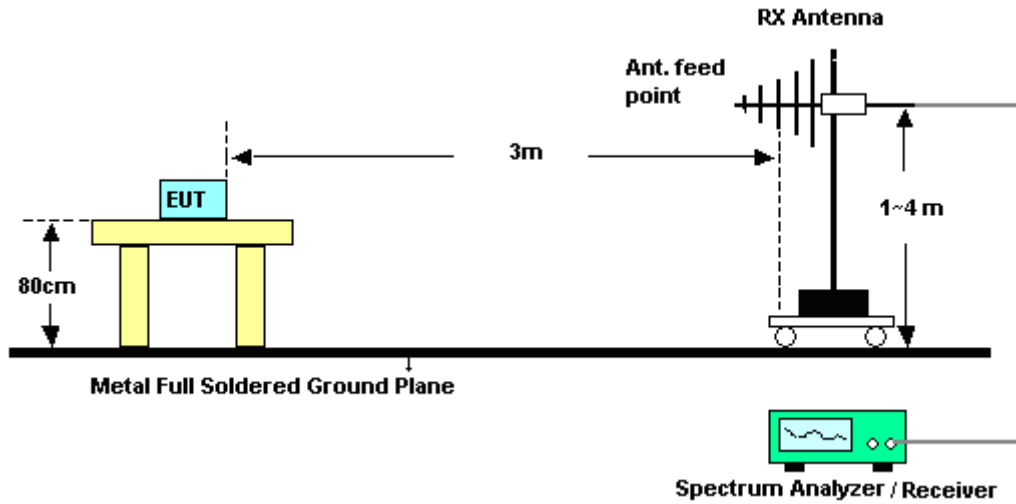

For radiated emissions above 1GHz

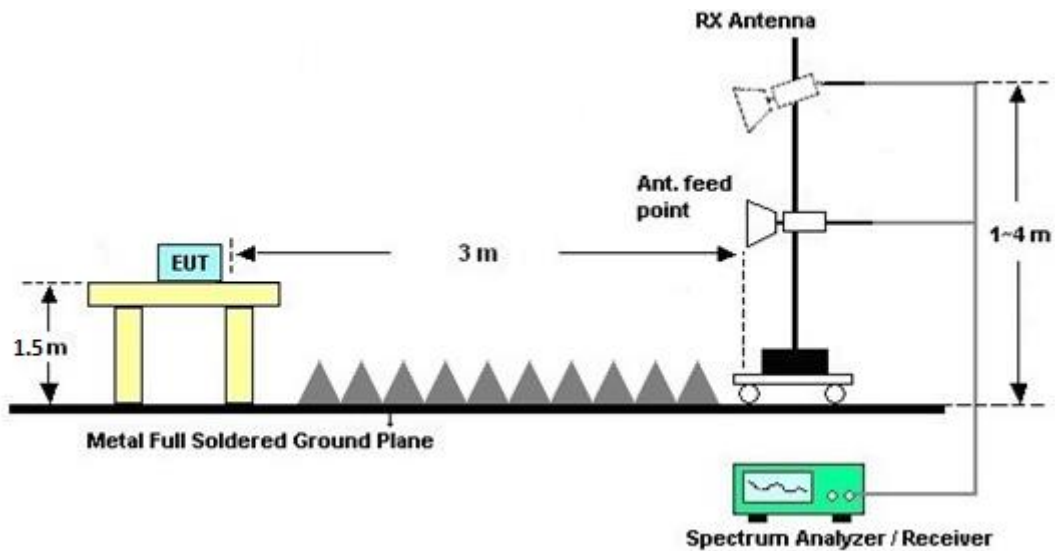



3.1.5 Test Results of Radiated Emissions (9 kHz ~ 30 MHz)

The low frequency, which started from 9 kHz to 30MHz, was pre-scanned and the result which was 20dB lower than the limit line per 15.31(o) was not reported.

3.1.6 Test Result of Radiated Band Edges

Please refer to Appendix A and B

3.1.7 Duty Cycle

Please refer to Appendix C.

3.1.8 Test Result of Unwanted Radiated Emission (30MHz ~ 10th Harmonic)

Please refer to Appendix A and B



3.2 AC Conducted Emission Measurement

3.2.1 Limit of AC Conducted Emission

For equipment that is designed to be connected to the public utility (AC) power line, the radio frequency voltage that is conducted back onto the AC power line on any frequency or frequencies within the band 150 kHz to 30 MHz shall not exceed the limits in the following table.

Frequency of emission (MHz)	Conducted limit (dB μ V)	
	Quasi-peak	Average
0.15-0.5	66 to 56*	56 to 46*
0.5-5	56	46
5-30	60	50

*Decreases with the logarithm of the frequency.

3.2.2 Measuring Instruments

The measuring equipment is listed in the section 4 of this test report.

3.2.3 Test Procedures

1. The EUT was placed 0.4 meter from the conducting wall of the shielding room was kept at least 80 centimeters from any other grounded conducting surface.
2. Connect EUT to the power mains through a line impedance stabilization network (LISN).
3. All the support units are connecting to the other LISN.
4. The LISN provides 50 ohm coupling impedance for the measuring instrument.
5. The FCC states that a 50 ohm, 50 microhenry LISN should be used.
6. Both sides of AC line were checked for maximum conducted interference.
7. The frequency range from 150 kHz to 30 MHz was searched.
8. Set the test-receiver system to Peak Detect Function and specified bandwidth with Maximum Hold Mode.

3.2.4 Test Setup

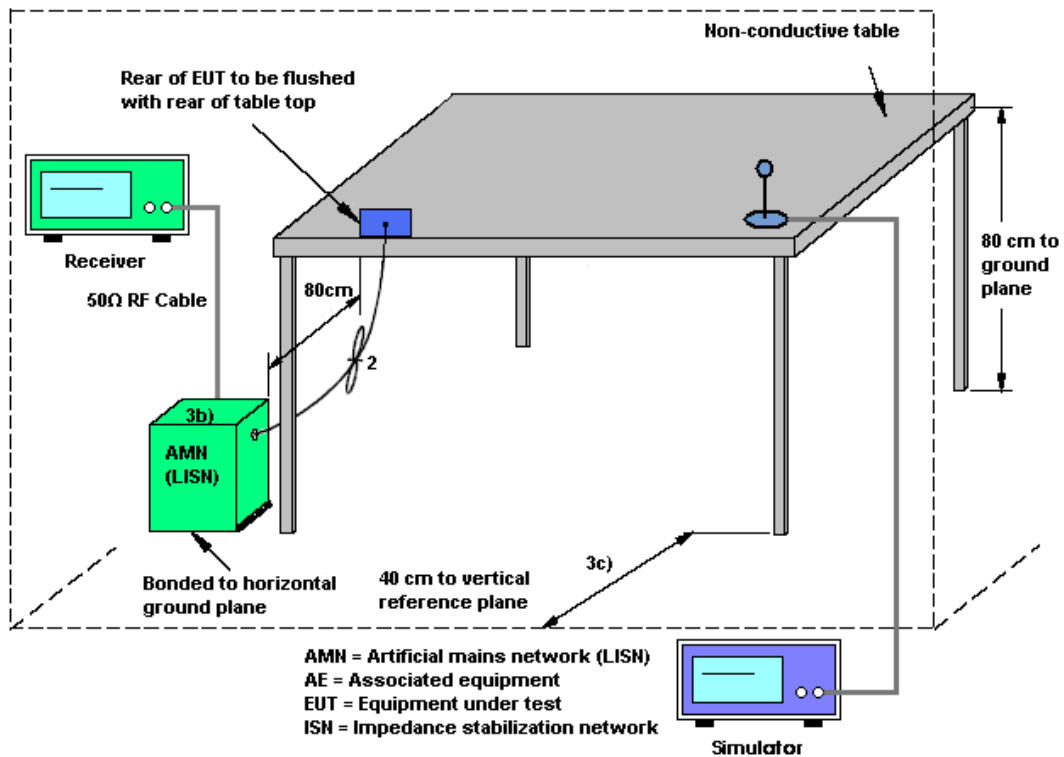



3.2.5 Test Result of AC Conducted Emission

Test Mode :	Mode 2	Temperature :	22~23°C
Test Engineer :	Arthur Hsieh and Kai-Chun Chu	Relative Humidity :	51~52%
Test Voltage :	120Vac / 60Hz	Phase :	Line
Function Type :	WCDMA Band V Idle + Bluetooth Link + WLAN (5GHz) Link + MPEG4 + WPC Back Cover + PMA Charging Pad + Adapter		

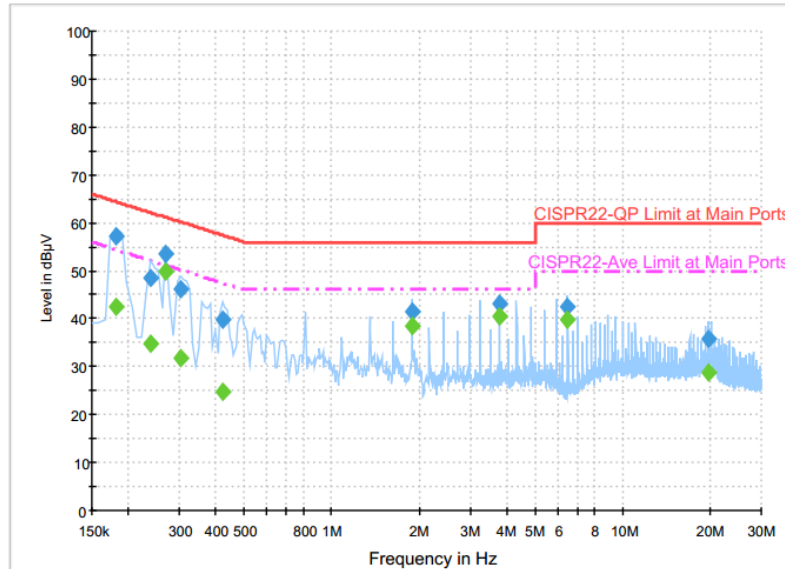

Final Result : QuasiPeak

Frequency (MHz)	QuasiPeak (dBµV)	Filter	Line	Corr. (dB)	Margin (dB)	Limit (dBµV)
0.182000	57.1	Off	L1	19.6	7.3	64.4
0.238000	48.4	Off	L1	19.6	13.8	62.2
0.270000	53.4	Off	L1	19.6	7.7	61.1
0.302000	46.0	Off	L1	19.6	14.2	60.2
0.422000	39.8	Off	L1	19.6	17.6	57.4
1.894000	41.6	Off	L1	19.7	14.4	56.0
3.790000	43.2	Off	L1	19.8	12.8	56.0
6.494000	42.6	Off	L1	20.0	17.4	60.0
19.750000	35.7	Off	L1	20.7	24.3	60.0

Final Result : Average

Frequency (MHz)	Average (dBµV)	Filter	Line	Corr. (dB)	Margin (dB)	Limit (dBµV)
0.182000	42.4	Off	L1	19.6	12.0	54.4
0.238000	34.9	Off	L1	19.6	17.3	52.2
0.270000	49.7	Off	L1	19.6	1.4	51.1
0.302000	31.8	Off	L1	19.6	18.4	50.2
0.422000	24.6	Off	L1	19.6	22.8	47.4
1.894000	38.6	Off	L1	19.7	7.4	46.0
3.790000	40.5	Off	L1	19.8	5.5	46.0
6.494000	39.9	Off	L1	20.0	10.1	50.0
19.750000	28.9	Off	L1	20.7	21.1	50.0



Test Mode :	Mode 2	Temperature :	22~23°C
Test Engineer :	Arthur Hsieh and Kai-Chun Chu	Relative Humidity :	51~52%
Test Voltage :	120Vac / 60Hz	Phase :	Neutral
Function Type :	WCDMA Band V Idle + Bluetooth Link + WLAN (5GHz) Link + MPEG4 + WPC Back Cover + PMA Charging Pad + Adapter		

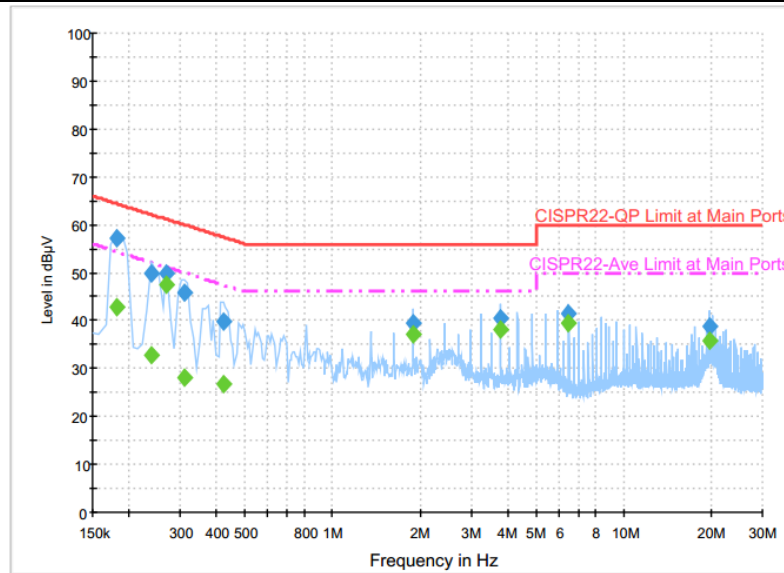

Final Result : QuasiPeak

Frequency (MHz)	QuasiPeak (dBµV)	Filter	Line	Corr. (dB)	Margin (dB)	Limit (dBµV)
0.182000	57.1	Off	N	19.6	7.3	64.4
0.238000	49.9	Off	N	19.6	12.3	62.2
0.270000	49.9	Off	N	19.6	11.2	61.1
0.310000	45.7	Off	N	19.6	14.3	60.0
0.422000	39.9	Off	N	19.6	17.5	57.4
1.894000	39.4	Off	N	19.7	16.6	56.0
3.790000	40.6	Off	N	19.7	15.4	56.0
6.494000	41.6	Off	N	19.9	18.4	60.0
19.758000	38.7	Off	N	20.8	21.3	60.0

Final Result : Average

Frequency (MHz)	Average (dBµV)	Filter	Line	Corr. (dB)	Margin (dB)	Limit (dBµV)
0.182000	42.8	Off	N	19.6	11.6	54.4
0.238000	32.7	Off	N	19.6	19.5	52.2
0.270000	47.5	Off	N	19.6	3.6	51.1
0.310000	28.0	Off	N	19.6	22.0	50.0
0.422000	26.9	Off	N	19.6	20.5	47.4
1.894000	37.1	Off	N	19.7	8.9	46.0
3.790000	38.2	Off	N	19.7	7.8	46.0
6.494000	39.4	Off	N	19.9	10.6	50.0
19.758000	35.7	Off	N	20.8	14.3	50.0



4 List of Measuring Equipment

Instrument	Manufacturer	Model No.	Serial No.	Characteristics	Calibration Date	Test Date	Due Date	Remark
AC Power Source	ChainTek	APC-1000W	N/A	N/A	N/A	Jul. 29, 2016	N/A	Conduction (CO05-HY)
EMI Test Receiver	Rohde & Schwarz	ESCI 7	100724	9kHz~7GHz	Aug. 26, 2015	Jul. 29, 2016	Aug. 25, 2016	Conduction (CO05-HY)
LISN	Rohde & Schwarz	ENV216	100080	9kHz~30MHz	Dec. 02, 2015	Jul. 29, 2016	Dec. 01, 2016	Conduction (CO05-HY)
Loop Antenna	Rohde & Schwarz	HFH2-Z2	100315	9 kHz~30 MHz	Sep. 02, 2015	Jul. 28, 2016 ~ Jul. 29, 2016	Sep. 01, 2016	Radiation (03CH11-HY)
Amplifier	SONOMA	310N	187312	9kHz~1GHz	Nov. 20, 2015	Jul. 28, 2016 ~ Jul. 29, 2016	Nov. 19, 2016	Radiation (03CH11-HY)
Bilog Antenna	TESEQ	CBL 6111D	35414	30MHz~1GHz	Nov. 17, 2015	Jul. 28, 2016 ~ Jul. 29, 2016	Nov. 16, 2016	Radiation (03CH11-HY)
Horn Antenna	SCHWARZBECK	BBHA 9120 D	9120D-1326	1GHz ~ 18GHz	Oct. 08, 2015	Jul. 28, 2016 ~ Jul. 29, 2016	Oct. 07, 2016	Radiation (03CH11-HY)
Preamplifier	Keysight	83017A	MY53270080	1GHz~26.5GHz	Nov. 19, 2015	Jul. 28, 2016 ~ Jul. 29, 2016	Nov. 18, 2016	Radiation (03CH11-HY)
Preamplifier	MITEQ	AMF-7D-0010 1800-30-10P	1902247	1GHz~18GHz	Jun. 22, 2016	Jul. 28, 2016 ~ Jul. 29, 2016	Jun. 21, 2017	Radiation (03CH11-HY)
Spectrum Analyzer	Keysight	N9010A	MY54200486	10Hz ~ 44GHZ	Sep. 24, 2015	Jul. 28, 2016 ~ Jul. 29, 2016	Sep. 23, 2016	Radiation (03CH11-HY)
Antenna Mast	EMEC	AM-BS-4500-B	N/A	1~4m	N/A	Jul. 28, 2016 ~ Jul. 29, 2016	N/A	Radiation (03CH11-HY)
Turn Table	EMEC	TT 2000	N/A	0~360 Degree	N/A	Jul. 28, 2016 ~ Jul. 29, 2016	N/A	Radiation (03CH11-HY)
SHF-EHF Horn Antenna	SCHWARZBECK	BBHA 9170	BBHA917058 4	18GHz- 40GHz	Nov. 02, 2015	Jul. 28, 2016 ~ Jul. 29, 2016	Nov. 01, 2016	Radiation (03CH11-HY)
Preamplifier	MITEQ	TTA0204	1872107	2GHz~40GHz	Feb. 15, 2016	Jul. 28, 2016 ~ Jul. 29, 2016	Feb. 14, 2017	Radiation (03CH11-HY)



5 Uncertainty of Evaluation

Uncertainty of Conducted Emission Measurement (150kHz ~ 30MHz)

Measuring Uncertainty for a Level of Confidence of 95% ($U = 2Uc(y)$)	2.26
---	------

Uncertainty of Radiated Emission Measurement (30 MHz ~ 1000 MHz)

Measuring Uncertainty for a Level of Confidence of 95% ($U = 2Uc(y)$)	3.37
---	------



Appendix A. Radiated Spurious Emission

Test Engineer :	J.C. Liang, Jacky Hung and Ken Wu	Temperature :	20~23°C
		Relative Humidity :	50~54%

Band 4 - 5725~5850MHz

WIFI 802.11n HT40 (Band Edge @ 3m)

<PMA Charging Mode>

WIFI Ant.	Note	Frequency	Level	Over Limit	Limit Line	Read Level	Antenna Factor	Cable Loss	Preamp Factor	Ant Pos	Table Pos	Peak Avg.	Pol.
1+2		(MHz)	(dBμV/m)	(dB)	(dBμV/m)	(dBμV)	(dB/m)	(dB)	(dB)	(cm)	(deg)	(P/A)	(H/V)
802.11n HT40 CH 159 5795MHz		5638.2	48.73	-19.57	68.3	39.39	32.19	10.69	33.54	391	137	P	H
		5676.6	50.17	-37.85	88.02	40.81	32.24	10.67	33.55	391	137	P	H
		5718.2	47.4	-63	110.4	38.01	32.31	10.65	33.57	391	137	P	H
		5722.2	50.05	-65.87	115.92	40.66	32.31	10.65	33.57	391	137	P	H
		5795	95.9	-26.4	122.3	86.47	32.41	10.61	33.59	391	137	P	H
		5795	87.31	-	-	77.88	32.41	10.61	33.59	391	137	A	H
		5851	56.03	-63.99	120.02	46.38	32.48	10.78	33.61	391	137	P	H
		5866.2	50.38	-57.38	107.76	40.55	32.51	10.94	33.62	391	137	P	H
		5876.2	49.62	-54.79	104.41	39.77	32.53	10.94	33.62	391	137	P	H
		5945.8	48.68	-19.62	68.3	38.43	32.63	11.27	33.65	391	137	P	H
		5637.6	48.55	-19.75	68.3	39.21	32.19	10.69	33.54	400	38	P	V
		5687.8	49.32	-46.98	96.3	39.94	32.27	10.67	33.56	400	38	P	V
		5700.8	49.47	-56.05	105.52	40.09	32.29	10.65	33.56	400	38	P	V
		5724.6	51.12	-70.27	121.39	41.73	32.31	10.65	33.57	400	38	P	V
		5795	100.1	-22.2	122.3	90.67	32.41	10.61	33.59	400	38	P	V
		5795	91.42	-	-	81.99	32.41	10.61	33.59	400	38	A	V
		5852.8	52.68	-63.24	115.92	43.03	32.48	10.78	33.61	400	38	P	V
		5867.2	51.9	-55.58	107.48	42.07	32.51	10.94	33.62	400	38	P	V
	5875.8	50.85	-53.86	104.71	41	32.53	10.94	33.62	400	38	P	V	
	5948.6	48.26	-20.04	68.3	38.01	32.63	11.27	33.65	400	38	P	V	

Remark	1. No other spurious found.
	2. All results are PASS against Peak and Average limit line.



Band 4 5725~5850MHz
WIFI 802.11n HT40 (Harmonic @ 3m)

Table with 14 columns: WIFI Ant. 1+2, Note, Frequency (MHz), Level (dBµV/m), Over Limit (dB), Limit Line (dBµV/m), Read Level (dBµV), Antenna Factor (dB/m), Cable Loss (dB), Preamp Factor (dB), Ant Pos (cm), Table Pos (deg), Peak Avg. (P/A), Pol. (H/V). Rows include data for 802.11n HT40 CH 159 5795MHz and a Remark section.



Note symbol

*	Fundamental Frequency which can be ignored. However, the level of any unwanted emissions shall not exceed the level of the fundamental frequency.
!	Test result is over limit line.
P/A	Peak or Average
H/V	Horizontal or Vertical



A calculation example for radiated spurious emission is shown as below:

WIFI	Note	Frequency	Level	Over	Limit	Read	Antenna	Cable	Preamp	Ant	Table	Peak	Pol.
Ant.				Limit	Line	Level	Factor	Loss	Factor	Pos	Pos	Avg.	
1+2		(MHz)	(dBμV/m)	(dB)	(dBμV/m)	(dBμV)	(dB/m)	(dB)	(dB)	(cm)	(deg)	(P/A)	(H/V)
802.11b		2390	55.45	-18.55	74	54.51	32.22	4.58	35.86	103	308	P	H
CH 01													
2412MHz		2390	43.54	-10.46	54	42.6	32.22	4.58	35.86	103	308	A	H

- Level(dBμV/m) =
Antenna Factor(dB/m) + Cable Loss(dB) + Read Level(dBμV) - Preamp Factor(dB)
- Over Limit(dB) = Level(dBμV/m) – Limit Line(dBμV/m)

For Peak Limit @ 2390MHz:

- Level(dBμV/m)
= Antenna Factor(dB/m) + Cable Loss(dB) + Read Level(dBμV) - Preamp Factor(dB)
= 32.22(dB/m) + 4.58(dB) + 54.51(dBμV) – 35.86 (dB)
= 55.45 (dBμV/m)
- Over Limit(dB)
= Level(dBμV/m) – Limit Line(dBμV/m)
= 55.45(dBμV/m) – 74(dBμV/m)
= -18.55(dB)

For Average Limit @ 2390MHz:

- Level(dBμV/m)
= Antenna Factor(dB/m) + Cable Loss(dB) + Read Level(dBμV) - Preamp Factor(dB)
= 32.22(dB/m) + 4.58(dB) + 42.6(dBμV) – 35.86 (dB)
= 43.54 (dBμV/m)
- Over Limit(dB)
= Level(dBμV/m) – Limit Line(dBμV/m)
= 43.54(dBμV/m) – 54(dBμV/m)
= -10.46(dB)

Both peak and average measured complies with the limit line, so test result is “PASS”.



Appendix B. Radiated Spurious Emission Plots

Test Engineer :	J.C. Liang, Jacky Hung and Ken Wu	Temperature :	20~23°C
		Relative Humidity :	50~54%



Band 4 - 5725~5850MHz

WIFI 802.11n HT40 (Band Edge @ 3m)

<PMA Charging Mode>

WIFI	Band 4 5725~5850MHz Band Edge @ 3m	
ANT	802.11n HT40 CH159 5795MHz	
1+2	Horizontal	Fundamental
Peak	<p>Site : 03CH11-HY Condition : PEAK_BE(B4)_16-24 3m HORN 9120D-HF HORIZONTAL RBW:1000.000KHz VBW:3000.000KHz SWT:Auto Detector : Peak Project : 651612-13 Mode : 2 : WPC cover + PMA</p>	<p>Site : 03CH11-HY Condition : PEAK(UNB) 3m HORN 9120D-HF HORIZONTAL RBW:1000.000KHz VBW:3000.000KHz SWT:Auto Detector : Peak Project : 651612-13 Mode : 2 : WPC cover + PMA</p>
Peak	<p>Site : 03CH11-HY Condition : PEAK_BE(B4)_16-24 3m HORN 9120D-HF HORIZONTAL RBW:1000.000KHz VBW:3000.000KHz SWT:Auto Detector : Peak Project : 651612-13 Mode : 2 : WPC cover + PMA</p>	Left blank



WIFI	Band 4 5725~5850MHz Band Edge @ 3m	
ANT	802.11n HT40 CH159 5795MHz	
1+2	Vertical	Fundamental
Peak	<p>Date: 2016-07-28</p> <p>Site : 03CH11-HY Condition : PEAK_BE(B4)_16-24 3m HORN 9120D-HF VERTICAL RBW:1000.000KHz VBW:3000.000KHz SWT:Auto Detector : Peak Project : 651612-13 Mode : 2 WPC cover + PMA</p>	<p>Date: 2016-07-28</p> <p>Site : 03CH11-HY Condition : PEAK(UM) 3m HORN 9120D-HF VERTICAL RBW:1000.000KHz VBW:3000.000KHz SWT:Auto Detector : Peak Project : 651612-13 Mode : 2 WPC cover + PMA</p>
Peak	<p>Date: 2016-07-28</p> <p>Site : 03CH11-HY Condition : PEAK_BE(B4)_16-24 3m HORN 9120D-HF VERTICAL RBW:1000.000KHz VBW:3000.000KHz SWT:Auto Detector : Peak Project : 651612-13 Mode : 2 WPC cover + PMA</p>	Left blank



Band 4 - 5725~5850MHz
WIFI 802.11n HT40 (Harmonic @ 3m)

Table with 2 main columns: Horizontal and Vertical. Each column contains a graph of Level (dBuV/m) vs Frequency (MHz) with peak and average values. Includes metadata like Site, Condition, Detector, Project, and Mode.



Emission below 1GHz
5GHz WIFI 802.11n HT40 (LF)

Table with 2 columns: Horizontal and Vertical. Each column contains a spectral plot of Level (dBuV/m) vs Frequency (MHz) from 50 to 1000 MHz. The plots show a blue signal line and a red QP limit line. Metadata for both plots includes Site: 03CH11-HY, Condition: QP 3m BI-LOG 6111D-LF_ETC, Detector: Peak, Project: 651612-13, and Mode: 2.



Appendix C. Duty Cycle Plots

Antenna	Band	Duty Cycle(%)	T(us)	1/T(kHz)	VBW Setting
1+2	802.11a	86.984	1370	0.730	1kHz
1+2	5GHz 802.11n HT20	86.486	1280	0.781	1kHz
1+2	5GHz 802.11n HT40	75.598	632	1.582	3kHz

802.11a

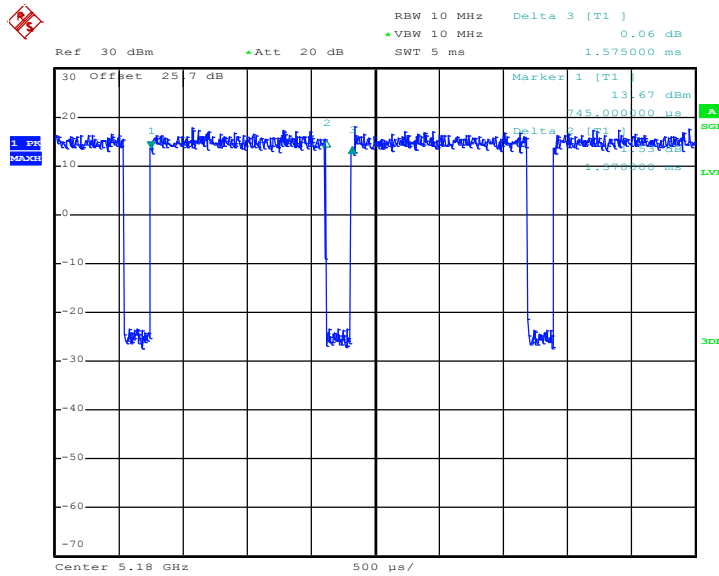

Date: 22.MAY.2016 09:02:32



802.11n HT20

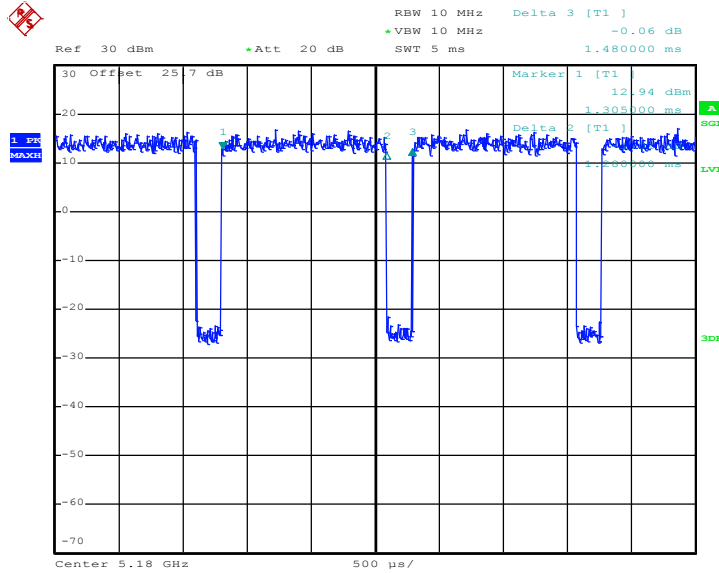

Date: 22.MAY.2016 09:08:23

802.11n HT40

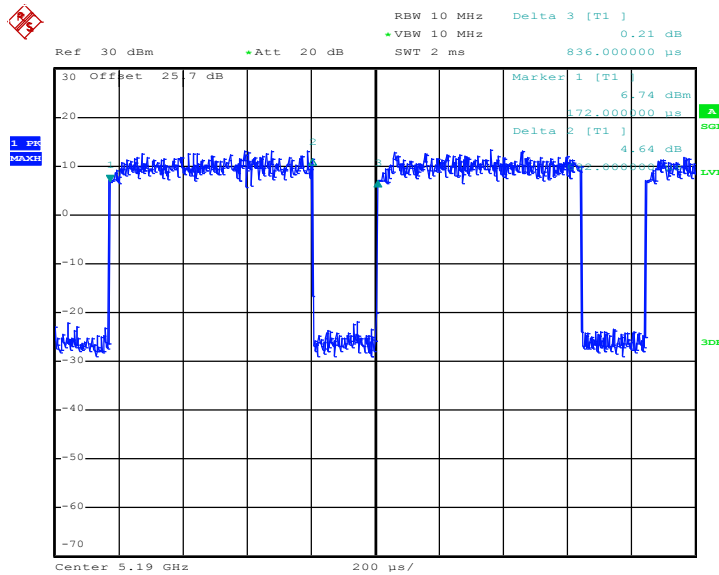

Date: 22.MAY.2016 09:23:04



Appendix D. Original Report

Please refer to Sporton report number FR651612E as below.



FCC RF Test Report

APPLICANT : Motorola Mobility, LLC
EQUIPMENT : Mobile Cellular Phone
BRAND NAME : Motorola
MODEL NAME : 5892
FCC ID : IHDT56VC1
STANDARD : FCC Part 15 Subpart E §15.407
CLASSIFICATION : (NII) Unlicensed National Information Infrastructure

The product was received on May 16, 2016 and testing was completed on Jun. 22, 2016. We, SPORTON INTERNATIONAL INC., would like to declare that the tested sample has been evaluated in accordance with the test procedures and has been in compliance with the applicable technical standards.

The test results in this report apply exclusively to the tested model / sample. Without written approval of SPORTON INTERNATIONAL INC., the test report shall not be reproduced except in full.

Reviewed by: Joseph Lin / Supervisor

Approved by: Jones Tsai / Manager



SPORTON INTERNATIONAL INC.

No. 52, Hwa Ya 1st Rd., Hwa Ya Technology Park, Kwei-Shan District, Tao Yuan City, Taiwan, R.O.C.

SPORTON INTERNATIONAL INC.

TEL : 886-3-327-3456

FAX : 886-3-328-4978

FCC ID : IHDT56VC1

Page Number : 1 of 33

Report Issued Date : Jun. 28, 2016

Report Version : Rev. 01

Report Template No.: BU5-FR15EWLB4 AC MA Version 1.2



TABLE OF CONTENTS

REVISION HISTORY 3

SUMMARY OF TEST RESULT 4

1 GENERAL DESCRIPTION 5

 1.1 Applicant 5

 1.2 Manufacturer 5

 1.3 Product Feature of Equipment Under Test 5

 1.4 Product Specification of Equipment Under Test 6

 1.5 Modification of EUT 6

 1.6 Testing Location 7

 1.7 Applicable Standards 8

2 TEST CONFIGURATION OF EQUIPMENT UNDER TEST 9

 2.1 Carrier Frequency and Channel 9

 2.2 Pre-Scanned RF Power 10

 2.3 Test Mode 11

 2.4 Connection Diagram of Test System 12

 2.5 Support Unit used in test configuration and system 13

 2.6 EUT Operation Test Setup 13

 2.7 Measurement Results Explanation Example 13

3 TEST RESULT 14

 3.1 6dB and 26dB and 99% Occupied Bandwidth Measurement 14

 3.2 Maximum Conducted Output Power Measurement 17

 3.3 Power Spectral Density Measurement 18

 3.4 Unwanted Emissions Measurement 20

 3.5 AC Conducted Emission Measurement 25

 3.6 Frequency Stability Measurement 29

 3.7 Automatically Discontinue Transmission 30

 3.8 Antenna Requirements 31

4 LIST OF MEASURING EQUIPMENT 32

5 UNCERTAINTY OF EVALUATION 33

APPENDIX A. CONDUCTED TEST RESULTS

APPENDIX B. RADIATED SPURIOUS EMISSION

APPENDIX C. RADIATED SPURIOUS EMISSION PLOTS

APPENDIX D. DUTY CYCLE PLOTS



SUMMARY OF TEST RESULT

Report Section	FCC Rule	Description	Limit	Result	Remark
3.1	15.403(i)	6dB, 26dB and 99% Occupied Bandwidth	> 500kHz	Pass	-
3.2	15.407(a)	Maximum Conducted Output Power	≤ 30 dBm	Pass	-
3.3	15.407(a)	Power Spectral Density	≤ 30 dBm/500kHz	Pass	-
3.4	15.407(b)	Unwanted Emissions	15.407(b)(4)(i) ≤ -17, -27 dBm/MHz &15.209(a)	Pass	Under limit 3.23 dB at 34.590 MHz
3.5	15.207	AC Conducted Emission	15.207(a)	Pass	Under limit 20.60 dB at 0.158 MHz
3.6	15.407(g)	Frequency Stability	Within Operation Band	Pass	-
3.7	15.407(c)	Automatically Discontinue Transmission	Discontinue Transmission	Pass	-
3.8	15.203 & 15.407(a)	Antenna Requirement	N/A	Pass	-



1 General Description

1.1 Applicant

Motorola Mobility, LLC

222 W Merchandise Mart Plaza, Suite 1800, Chicago, IL 60654, United States

1.2 Manufacturer

Motorola Mobility, LLC

222 W Merchandise Mart Plaza, Suite 1800, Chicago, IL 60654, United States

1.3 Product Feature of Equipment Under Test

Product Feature	
Equipment	Mobile Cellular Phone
Brand Name	Motorola
Model Name	5892
FCC ID	IHDT56VC1
IMEI Code	354130070011751 (for Radiation) 354130070013450 (for Conduction)
EUT supports Radios application	CDMA/EV-DO/GSM/EGPRS/WCDMA/HSPA/LTE/NFC WLAN 11b/g/n HT20 WLAN 11a/n HT20/HT40 Bluetooth v3.0 EDR Bluetooth v4.0 LE
EUT Stage	Identical Prototype

Remark: The above EUT's information was declared by manufacturer. Please refer to the specifications or user's manual for more detailed description.

Accessory List	
AC Adapter	Brand Name : Motorola
	Model Name : SPN5913A
Battery 1	Brand Name : Motorola
	Model Name : SNN5974A
Battery 2	Brand Name : Motorola
	Model Name : SNN5975A
Earphone	Brand Name : Motorola
	Model Name : SJYN1181B
USB Cable	Brand Name : Motorola
	Model Name : SKN6473A



1.4 Product Specification of Equipment Under Test

Standards-related Product Specification	
Tx/Rx Channel Frequency Range	5745 MHz ~ 5825 MHz
Maximum Output Power	802.11a : 16.34 dBm / 0.0431 W 802.11n HT20 : 15.32 dBm / 0.0340 W 802.11n HT40 : 14.93 dBm / 0.0311 W
99% Occupied Bandwidth	802.11a : 19.25 MHz 802.11n HT20 : 19.50 MHz 802.11n HT40 : 37.10 MHz
Type of Modulation	802.11a/n : OFDM (BPSK / QPSK / 16QAM / 64QAM)
Antenna Type	ILA Antenna (The antenna peak gain of EUT is less than 6 dBi)

1.5 Modification of EUT

No modifications are made to the EUT during all test items.



1.6 Testing Location

Sporton Lab is accredited to ISO 17025 by Taiwan Accreditation Foundation (TAF code : 1190) and the FCC designation No. TW1022 under the FCC 2.948(e) by Mutual Recognition Agreement (MRA) in FCC Test.

Test Site	SPORTON INTERNATIONAL INC.	
Test Site Location	No. 52, Hwa Ya 1 st Rd., Hwa Ya Technology Park, Kwei-Shan District, Tao Yuan City, Taiwan, R.O.C. TEL: +886-3-327-3456 FAX: +886-3-328-4978	
Test Site No.	Sporton Site No.	
	TH05-HY	CO05-HY

Note: The test site complies with ANSI C63.4 2014 requirement.

Test Site	SPORTON INTERNATIONAL INC.	
Test Site Location	No.58, Aly. 75, Ln. 564, Wenhua 3rd Rd. Guishan Dist, Taoyuan City, Taiwan (R.O.C.) TEL: +886-3-327-0868 FAX: +886-3-327-0855	
Test Site No.	Sporton Site No.	
	03CH11-HY	

Note: The test site complies with ANSI C63.4 2014 requirement.



1.7 Applicable Standards

According to the specifications of the manufacturer, the EUT must comply with the requirements of the following standards:

- ♦ FCC Part 15 Subpart E
- ♦ FCC KDB 789033 D02 General UNII Test Procedures New Rules v01r02
- ♦ ANSI C63.10-2013

Remark:

1. All test items were verified and recorded according to the standards and without any deviation during the test.
2. This EUT has also been tested and complied with the requirements of FCC Part 15, Subpart B, recorded in a separate test report.



2 Test Configuration of Equipment Under Test

The EUT has been associated with peripherals and configuration operated in a manner tended to maximize its emission characteristics in a typical application. Frequency range investigated: conducted emission (150 kHz to 30 MHz) and radiated emission (9 kHz to the 10th harmonic of the highest fundamental frequency or to 40 GHz, whichever is lower). For radiated measurement, pre-scanned in three orthogonal panels, X, Y, Z. The worst cases (X plane) were recorded in this report.

The final configuration from all the combinations and the worst-case data rates were investigated by measuring the maximum power across all the data rates and modulation modes under section 2.2.

Based on the worst configuration found above, the RF power setting is set individually to meet FCC compliance limit for the final conducted and radiated tests shown in section 2.3.

2.1 Carrier Frequency and Channel

Frequency Band	Channel	Freq. (MHz)	Channel	Freq. (MHz)
5725-5850 MHz Band 4 (U-NII-3)	149	5745	157	5785
	151	5755	159	5795
	153	5765	161	5805
	155	5775	165	5825

Note: The above Frequency and Channel in boldface were 802.11n HT40.



2.2 Pre-Scanned RF Power

Preliminary tests were performed in different data rate and data rate associated with the highest power were chosen for full test in the following tables. Final Output Power equals to Measured Output Power adds the duty factor.

Channel	Frequency	5GHz 802.11a Average Power (dBm)							
		Data Rate							
		6 Mbps	9 Mbps	12 Mbps	18 Mbps	24 Mbps	36 Mbps	48 Mbps	54 Mbps
CH 149	5745 MHz	15.80	15.42	15.44	15.48	15.48	14.77	13.72	13.12
CH 157	5785 MHz	16.22	15.71	15.65	15.67	15.71	14.73	13.88	13.31
CH 165	5825 MHz	16.34	15.84	15.97	15.87	15.98	15.22	14.31	13.57

Channel	Frequency	5GHz 802.11n HT20 Average Power (dBm)							
		Data Rate							
		MCS0	MCS1	MCS2	MCS3	MCS4	MCS5	MCS6	MCS7
CH 149	5745 MHz	14.78	14.77	14.68	14.71	14.75	13.93	13.27	12.37
CH 157	5785 MHz	15.12	15.06	15.07	15.09	15.09	14.51	13.72	12.77
CH 165	5825 MHz	15.32	15.28	15.27	15.30	15.31	14.80	13.99	12.97

Channel	Frequency	5GHz 802.11n HT40 Average Power (dBm)							
		Data Rate							
		MCS0	MCS1	MCS2	MCS3	MCS4	MCS5	MCS6	MCS7
CH 151	5755 MHz	14.58	14.41	14.53	14.57	13.82	13.81	12.91	12.25
CH 159	5795 MHz	14.93	14.86	14.91	14.84	14.13	14.06	13.15	12.20



2.3 Test Mode

Final test mode of conducted test items and radiated spurious emissions are considering the modulation and worse data rates from the power table described in section 2.2.

Modulation	Data Rate
802.11a	6 Mbps
802.11n HT20	MCS0
802.11n HT40	MCS0

AC Conducted Emission	Mode 1 : GSM850 Idle + Bluetooth Link + WLAN (5GHz) Link + Earphone + MP3 + Adapter
--------------------------------------	---

Ch. #		Band IV : 5725-5850 MHz		
		802.11a	802.11n HT20	802.11n HT40
L	Low	149	149	151
M	Middle	157	157	-
H	High	165	165	159

2.4 Connection Diagram of Test System

<WLAN Tx Mode>

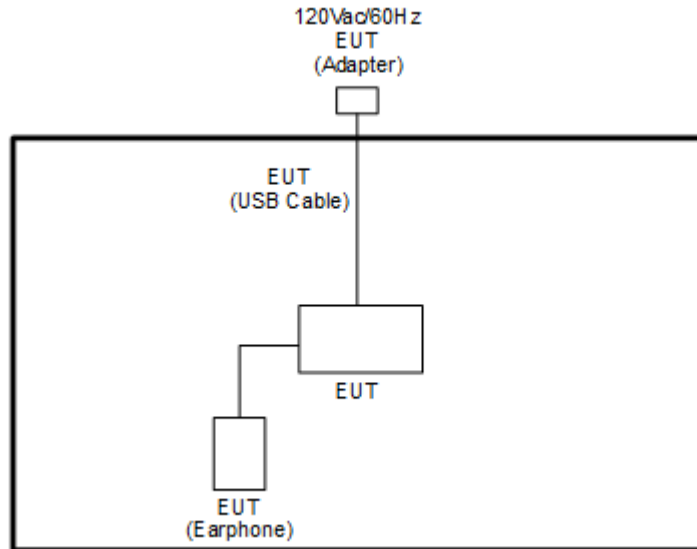

<AC Conducted Emission Mode>

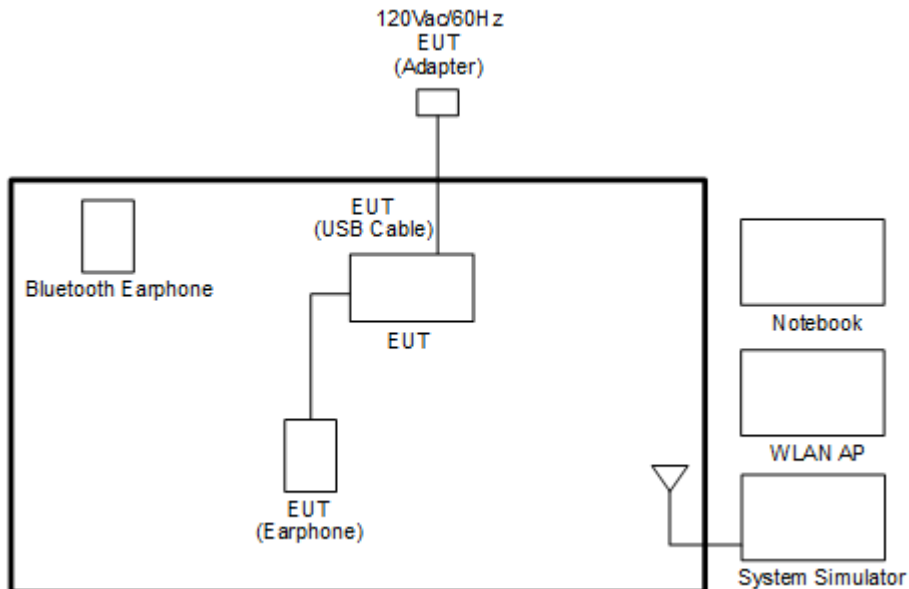



2.5 Support Unit used in test configuration and system

Item	Equipment	Trade Name	Model Name	FCC ID	Data Cable	Power Cord
1.	System Simulator	Anritsu	MT8820C	N/A	N/A	Unshielded, 1.8 m
2.	WLAN AP	D-Link	DIR-865L	KA2IR865LA1	N/A	Unshielded, 1.8 m
3.	Notebook	DELL	Latitude E6320	FCC DoC/ Contains FCC ID: QDS-BRCM1054	N/A	AC I/P: Unshielded, 1.2 m DC O/P: Shielded, 1.8 m
4.	Bluetooth Earphone	Sony Ericsson	MW600	PY7DDA-2029	N/A	N/A
5.	SD Card	SanDisk	MicroSD HC	FCC DoC	N/A	N/A

2.6 EUT Operation Test Setup

For WLAN function, programmed RF utility, “QRCT” installed in the notebook make the EUT provide functions like channel selection and power level for continuous transmitting and receiving signals.

2.7 Measurement Results Explanation Example

For all conducted test items:

The offset level is set in the spectrum analyzer to compensate the RF cable loss and attenuator factor between EUT conducted output port and spectrum analyzer. With the offset compensation, the spectrum analyzer reading level is exactly the EUT RF output level.

Example :

The spectrum analyzer offset is derived from RF cable loss and attenuator factor.

Offset = RF cable loss + attenuator factor.

Following shows an offset computation example with cable loss 4.2 dB and 10dB attenuator.

$$\begin{aligned}
 \text{Offset(dB)} &= \text{RF cable loss(dB)} + \text{attenuator factor(dB)}. \\
 &= 4.2 + 10 = 14.2 \text{ (dB)}
 \end{aligned}$$

3 Test Result

3.1 6dB and 26dB and 99% Occupied Bandwidth Measurement

3.1.1 Description of 6dB and 26dB and 99% Occupied Bandwidth

The minimum 6 dB bandwidth shall be at least 500 kHz.

26dB and 99% Occupied bandwidth are reporting only.

3.1.2 Measuring Instruments

The measuring equipment is listed in the section 4 of this test report.

3.1.3 Test Procedures

1. The testing follows FCC KDB 789033 D02 General UNII Test Procedures New Rules v01r02.
Section C) Emission bandwidth for the band 5.725-5.85GHz
2. Set RBW = 100kHz.
3. Set the VBW $\geq 3 \times$ RBW.
4. Detector = Peak.
5. Trace mode = max hold
6. Measure the maximum width of the emission that is 6 dB down from the peak of the emission.
7. Measure and record the results in the test report.

3.1.4 Test Setup

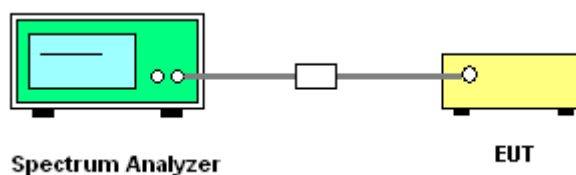



3.1.5 Test Result of 6dB Bandwidth

Please refer to Appendix A.

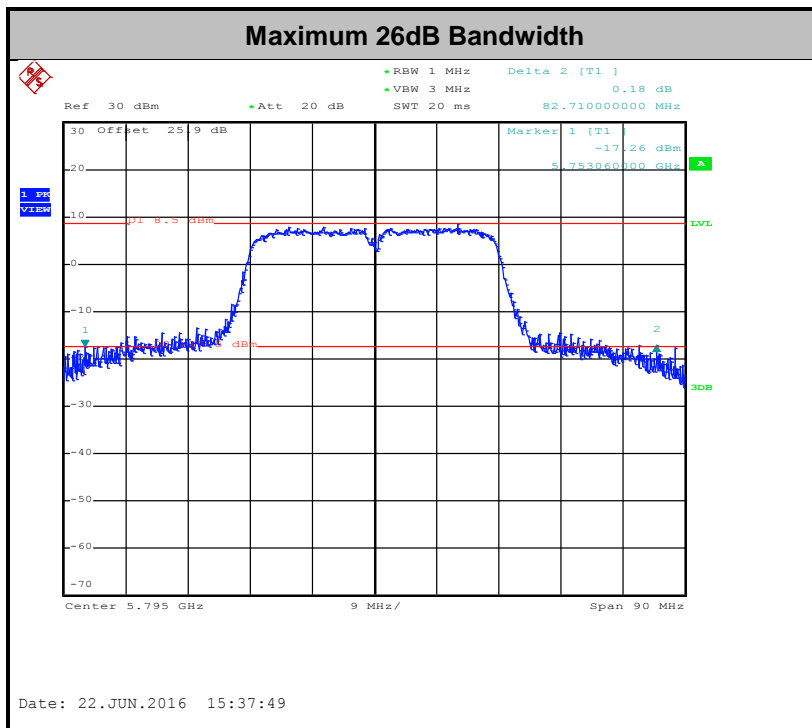
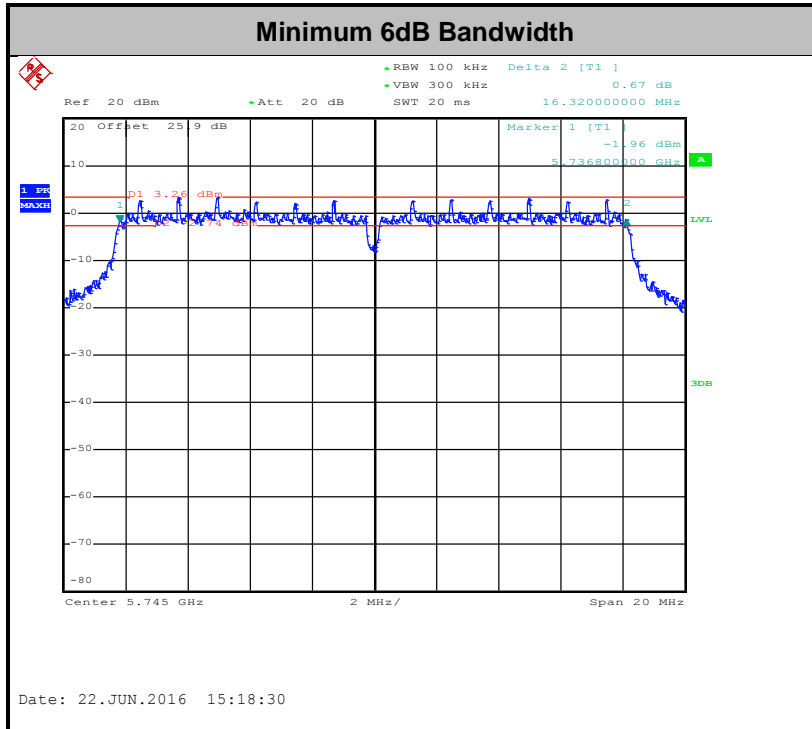

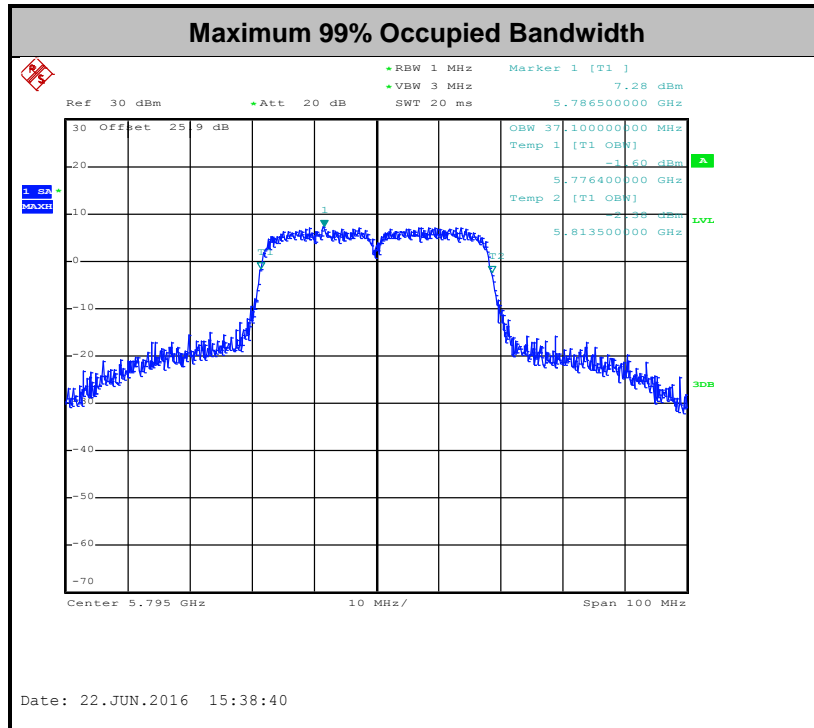

Note: The occupied channel bandwidth is maintained within the band of operation for all of the modulations.

3.2 Maximum Conducted Output Power Measurement

3.2.1 Limit of Maximum Conducted Output Power

For the band 5.725–5.85 GHz, the maximum conducted output power over the frequency band of operation shall not exceed 1 W.

If transmitting antennas of directional gain greater than 6 dBi are used, the peak output power shall be reduced by the amount in dB that the directional gain of the antenna exceeds 6 dBi.

3.2.2 Measuring Instruments

The measuring equipment is listed in the section 4 of this test report.

3.2.3 Test Procedures

The testing follows Method PM of FCC KDB 789033 D02 General UNII Test Procedures New Rules v01r02.

Method PM (Measurement using an RF average power meter):

1. Measurement is performed using a wideband RF power meter.
2. The EUT is configured to transmit continuously with a consistent duty cycle at its maximum power control level.
3. Measure the average power of the transmitter, and the average power is corrected with duty factor, $10 \log(1/x)$, where x is the duty cycle.

3.2.4 Test Setup

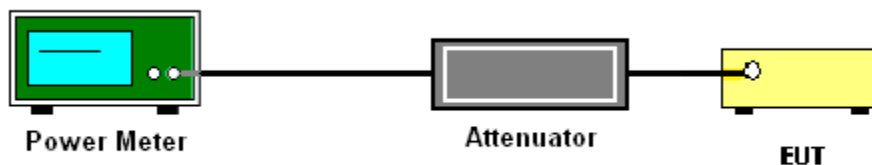

3.2.5 Test Result of Maximum Conducted Output Power

Please refer to Appendix A.



3.3 Power Spectral Density Measurement

3.3.1 Limit of Power Spectral Density

For the band 5.725–5.85 GHz, the maximum power spectral density shall not exceed 30 dBm in any 500-kHz band.

If transmitting antennas of directional gain greater than 6 dBi are used, the peak output power shall be reduced by the amount in dB that the directional gain of the antenna exceeds 6 dBi.

3.3.2 Measuring Instruments

The measuring equipment is listed in the section 4 of this test report.

3.3.3 Test Procedures

The testing follows FCC KDB 789033 D02 General UNII Test Procedures New Rules v01r02. Section F) Maximum power spectral density.

Method SA-2

(trace averaging across on and off times of the EUT transmissions, followed by duty cycle correction).

1. The testing follows Method SA-2 of FCC KDB 789033 D02 General UNII Test Procedures New Rules v01r02.
 - Measure the duty cycle.
 - Set span to encompass the entire emission bandwidth (EBW) of the signal.
 - Set RBW = 300 kHz.
 - Set VBW \geq 1 MHz.
 - Number of points in sweep \geq 2 Span / RBW.
 - Sweep time = auto.
 - Detector = RMS
 - Trace average at least 100 traces in power averaging mode.
 - Add $10 \log(500\text{kHz}/\text{RBW})$ to the test result.
 - Add $10 \log(1/x)$, where x is the duty cycle, to the measured power in order to compute the average power during the actual transmission times. For example, add $10 \log(1/0.25) = 6$ dB if the duty cycle is 25 percent.
2. The RF output of EUT was connected to the spectrum analyzer by a low loss cable.
3. Each plot has already offset with cable loss, and attenuator loss. Measure the PPSD and record it.



3.4 Unwanted Emissions Measurement

This section as specified in FCC Part 15.407(b) is to measure unwanted emissions through radiated measurement for band edge spurious emissions and out of band emissions measurement. The unwanted emissions shall comply with 15.407(b)(1) to (6), and restricted bands per FCC Part15.205.

3.4.1 Limit of Unwanted Emissions

- (1) For transmitters operating in the 5.725-5.85 GHz band:
15.407(b)(4)(i) All emissions shall be limited to a level of -27 dBm/MHz at 75 MHz or more above or below the band edge increasing linearly to 10 dBm/MHz at 25 MHz above or below the band edge, and from 25 MHz above or below the band edge increasing linearly to a level of 15.6 dBm/MHz at 5 MHz above or below the band edge, and from 5 MHz above or below the band edge increasing linearly to a level of 27 dBm/MHz at the band edge.
- (2) For transmitters operating in the 5725-5850 MHz band:
all emissions within the frequency range from the band edge to 10 MHz above or below the band edge shall not exceed an EIRP of -17 dBm/MHz (78.3dBµV/m); for frequencies 10 MHz or greater above or below the band edge, emissions shall not exceed an EIRP of -27 dBm/MHz (68.3dBµV/m).
- (3) Unwanted spurious emissions fallen in restricted bands per FCC Part15.205 shall comply with the general field strength limits set forth in § 15.209 as below table,

Frequency (MHz)	Field Strength (microvolts/meter)	Measurement Distance (meters)
0.009 – 0.490	2400/F(kHz)	300
0.490 – 1.705	24000/F(kHz)	30
1.705 – 30.0	30	30
30 – 88	100	3
88 – 216	150	3
216 - 960	200	3
Above 960	500	3

Note: The following formula is used to convert the EIRP to field strength.

$$E = \frac{1000000\sqrt{30P}}{3} \mu\text{V/m, where P is the eirp (Watts)}$$



EIRP (dBm)	Field Strength at 3m (dBµV/m)
-17	78.3
- 27	68.3

(4) KDB 789033 D02 General UNII Test Procedures New Rules v01r02 G)2)c) As specified in 15.407(b), emissions above 1000 MHz that are outside of the restricted bands are subject to a peak emission limit of -27 dBm/MHz (or -17 dBm/MHz as specified in 15.407(b)(4)). However, an out-of-band emission that complies with both the average and peak limits of 15.209 is not required to satisfy the -27 dBm/MHz or -17 dBm/MHz peak emission limit.

3.4.2 Measuring Instruments

The measuring equipment is listed in the section 4 of this test report.

3.4.3 Test Procedures

1. The testing follows FCC KDB 789033 D02 General UNII Test Procedures New Rules v01r02. Section G) Unwanted emissions measurement.

(1) Procedure for Unwanted Emissions Measurements Below 1000MHz

- RBW = 120 kHz
- VBW = 300 kHz
- Detector = Peak
- Trace mode = max hold

(2) Procedure for Peak Unwanted Emissions Measurements Above 1000 MHz

- RBW = 1 MHz
- VBW ≥ 3 MHz
- Detector = Peak
- Sweep time = auto
- Trace mode = max hold

(3) Procedures for Average Unwanted Emissions Measurements Above 1000MHz

- RBW = 1 MHz
- VBW = 10 Hz, when duty cycle is no less than 98 percent.
- VBW ≥ 1/T, when duty cycle is less than 98 percent where T is the minimum transmission duration over which the transmitter is on and is transmitting at its maximum power control level for the tested mode of operation.

2. The EUT was placed on a turntable with 0.8 meter for frequency below 1GHz and 1.5 meter for frequency above 1GHz respectively above ground.
3. The EUT was set 3 meters from the interference receiving antenna which was mounted on the top of a variable height antenna tower.
4. The antenna is a broadband antenna and its height is adjusted between one meter and four meters above ground to find the maximum value of the field strength for both horizontal polarization and vertical polarization of the antenna.
5. For each suspected emission, the EUT was arranged to its worst case and then adjust the antenna tower (from 1 m to 4 m) and turntable (from 0 degree to 360 degrees) to find the maximum reading.
6. For testing below 1GHz, if the emission level of the EUT in peak mode was 3 dB lower than the limit specified, then peak values of EUT will be reported, otherwise, the emissions will be repeated one by one using the CISPR quasi-peak method and reported.
7. For testing above 1GHz, the emission level of the EUT in peak mode was 20dB lower than average limit (that means the emission level in average mode also complies with the limit in average mode), then peak values of EUT will be reported, otherwise, the emissions will be measured in average mode again and reported.

3.4.4 Test Setup

For radiated emissions below 30MHz

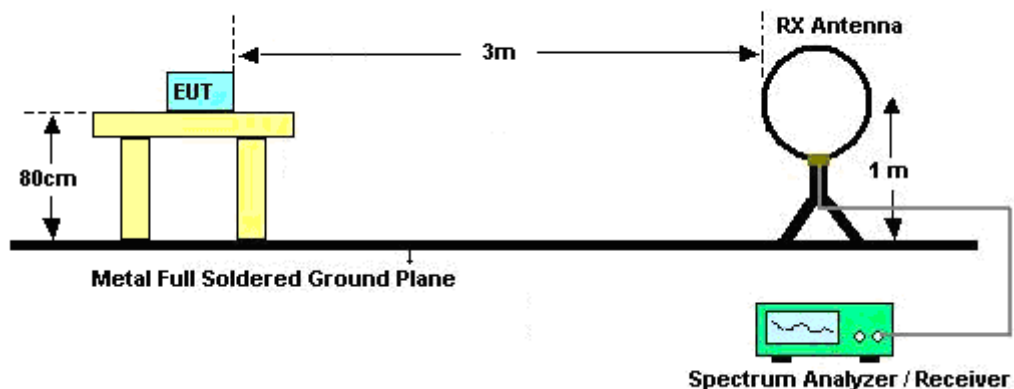

For radiated emissions from 30MHz to 1GHz

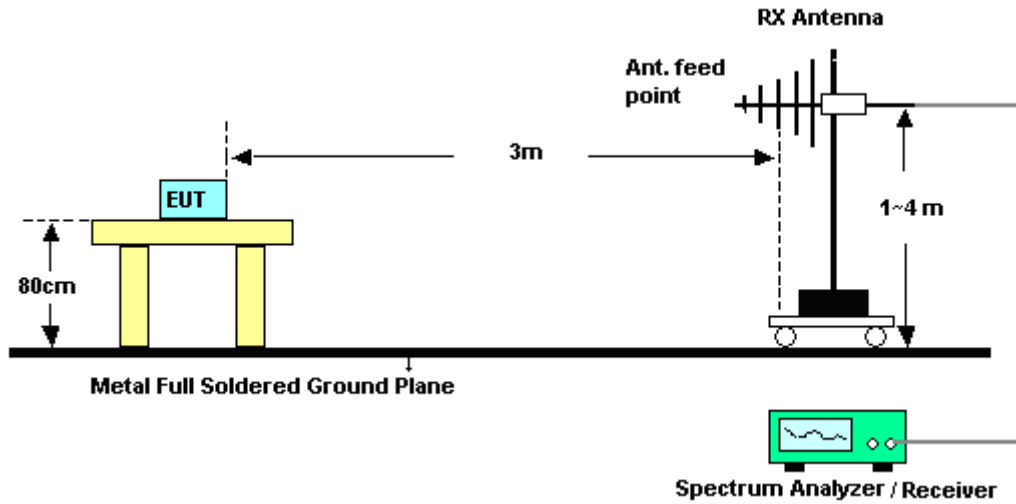

For radiated emissions above 1GHz

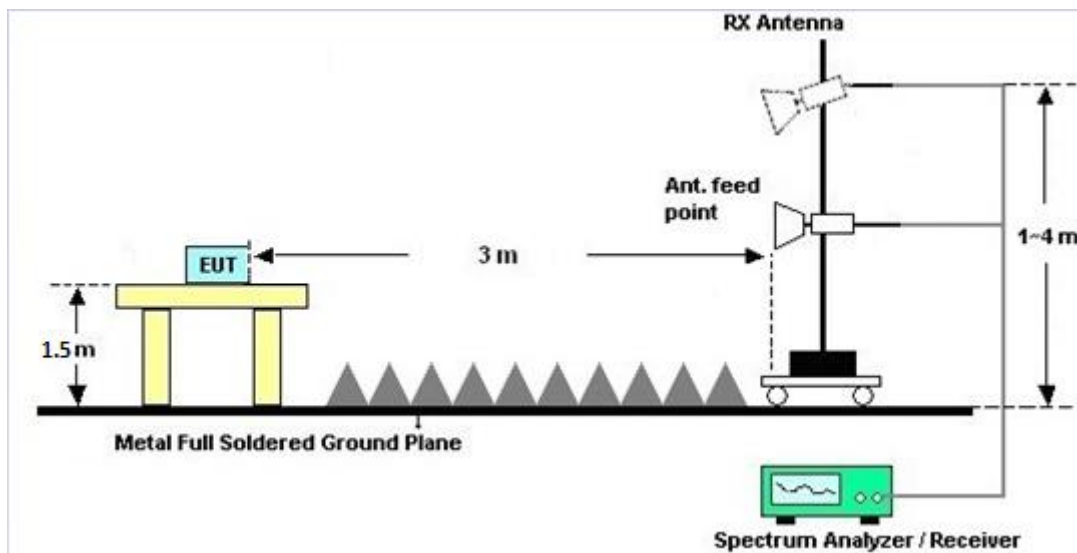



3.4.5 Test Results of Radiated Emissions (9 kHz ~ 30 MHz)

The low frequency, which started from 9 kHz to 30MHz, was pre-scanned and the result which was 20dB lower than the limit line per 15.31(o) was not reported.

3.4.6 Test Result of Radiated Band Edges

Please refer to Appendix B and C.

3.4.7 Duty Cycle

Please refer to Appendix D.

3.4.8 Test Result of Unwanted Radiated Emission (30MHz ~ 10th Harmonic)

Please refer to Appendix B and C.



3.5 AC Conducted Emission Measurement

3.5.1 Limit of AC Conducted Emission

For equipment that is designed to be connected to the public utility (AC) power line, the radio frequency voltage that is conducted back onto the AC power line on any frequency or frequencies within the band 150 kHz to 30 MHz shall not exceed the limits in the following table.

Frequency of emission (MHz)	Conducted limit (dB μ V)	
	Quasi-peak	Average
0.15-0.5	66 to 56*	56 to 46*
0.5-5	56	46
5-30	60	50

*Decreases with the logarithm of the frequency.

3.5.2 Measuring Instruments

The measuring equipment is listed in the section 4 of this test report.

3.5.3 Test Procedures

1. The EUT was placed 0.4 meter from the conducting wall of the shielding room was kept at least 80 centimeters from any other grounded conducting surface.
2. Connect EUT to the power mains through a line impedance stabilization network (LISN).
3. All the support units are connecting to the other LISN.
4. The LISN provides 50 ohm coupling impedance for the measuring instrument.
5. The FCC states that a 50 ohm, 50 microhenry LISN should be used.
6. Both sides of AC line were checked for maximum conducted interference.
7. The frequency range from 150 kHz to 30 MHz was searched.
8. Set the test-receiver system to Peak Detect Function and specified bandwidth with Maximum Hold Mode.

3.5.4 Test Setup

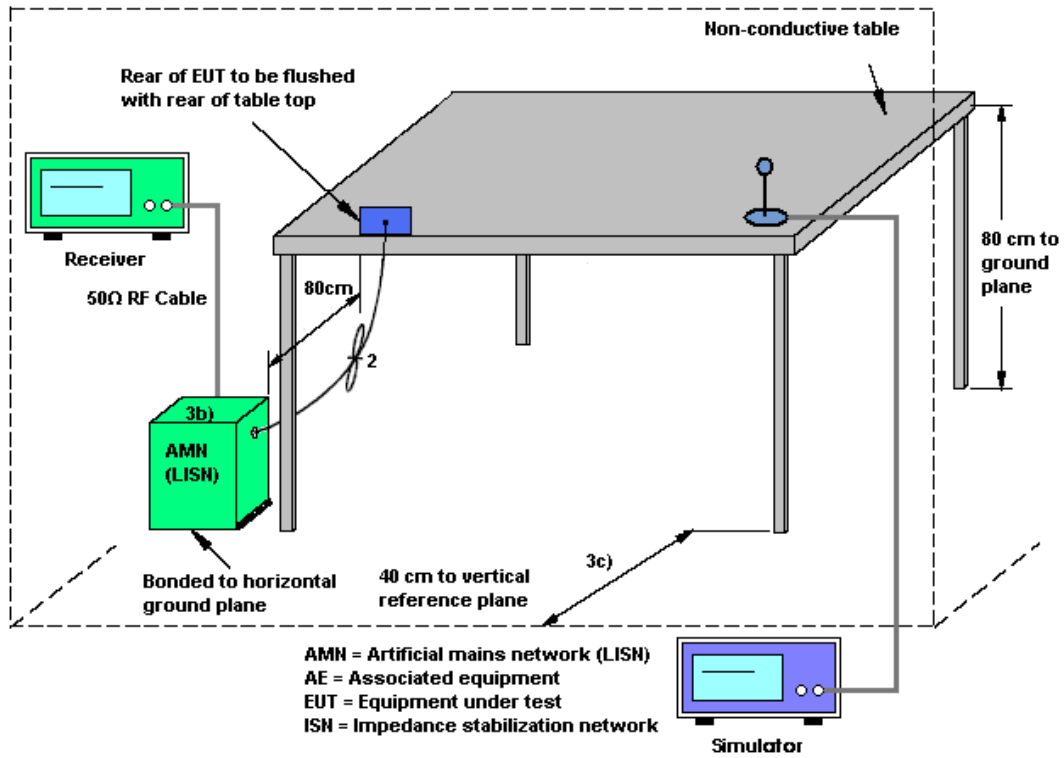



3.5.5 Test Result of AC Conducted Emission

Test Mode :	Mode 1	Temperature :	25~26°C
Test Engineer :	Kai-Chun Chu	Relative Humidity :	51~52%
Test Voltage :	120Vac / 60Hz	Phase :	Line
Function Type :	GSM850 Idle + Bluetooth Link + WLAN (5GHz) Link + Earphone + MP3 + Adapter		

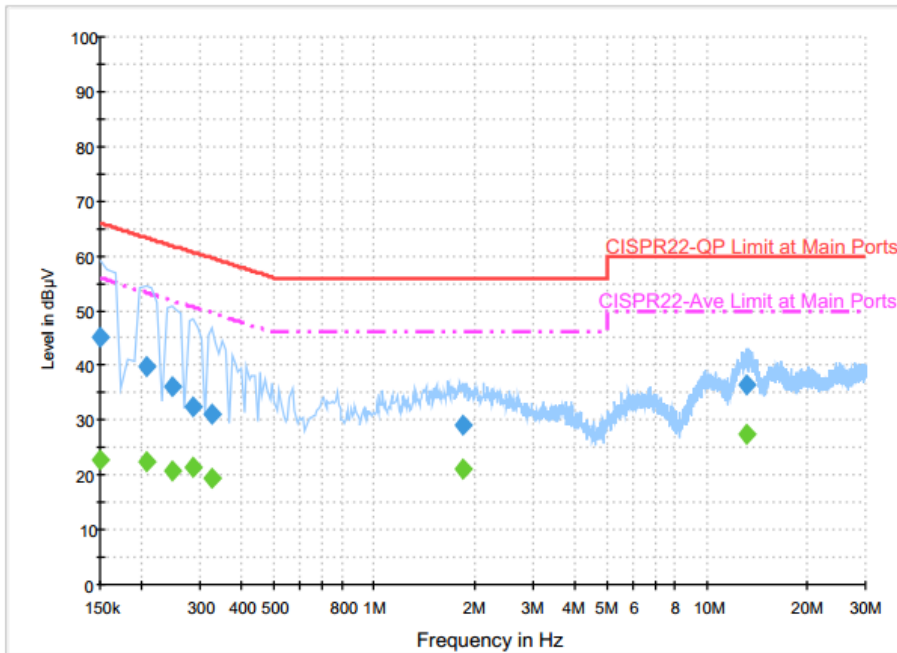

Final Result : QuasiPeak

Frequency (MHz)	QuasiPeak (dBµV)	Filter	Line	Corr. (dB)	Margin (dB)	Limit (dBµV)
0.150000	45.3	Off	L1	19.6	20.7	66.0
0.206000	39.6	Off	L1	19.6	23.8	63.4
0.246000	36.1	Off	L1	19.6	25.8	61.9
0.286000	32.4	Off	L1	19.6	28.2	60.6
0.326000	31.3	Off	L1	19.6	28.3	59.6
1.854000	29.2	Off	L1	19.7	26.8	56.0
13.254000	36.6	Off	L1	20.3	23.4	60.0

Final Result : Average

Frequency (MHz)	Average (dBµV)	Filter	Line	Corr. (dB)	Margin (dB)	Limit (dBµV)
0.150000	22.7	Off	L1	19.6	33.3	56.0
0.206000	22.6	Off	L1	19.6	30.8	53.4
0.246000	20.9	Off	L1	19.6	31.0	51.9
0.286000	21.5	Off	L1	19.6	29.1	50.6
0.326000	19.4	Off	L1	19.6	30.2	49.6
1.854000	21.1	Off	L1	19.7	24.9	46.0
13.254000	27.5	Off	L1	20.3	22.5	50.0



Test Mode :	Mode 1	Temperature :	25~26°C
Test Engineer :	Kai-Chun Chu	Relative Humidity :	51~52%
Test Voltage :	120Vac / 60Hz	Phase :	Neutral
Function Type :	GSM850 Idle + Bluetooth Link + WLAN (5GHz) Link + Earphone + MP3 + Adapter		

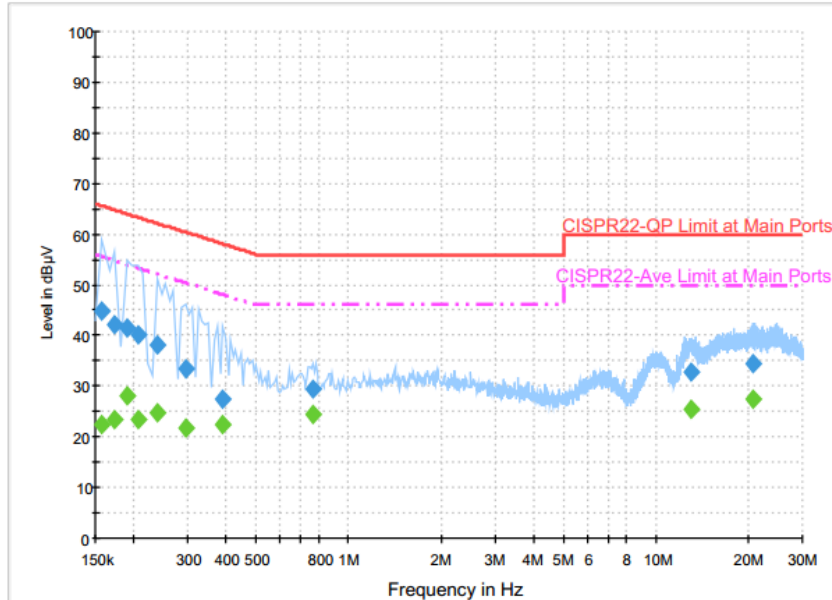

Final Result : QuasiPeak

Frequency (MHz)	QuasiPeak (dBµV)	Filter	Line	Corr. (dB)	Margin (dB)	Limit (dBµV)
0.158000	45.0	Off	N	19.6	20.6	65.6
0.174000	42.2	Off	N	19.6	22.6	64.8
0.190000	41.6	Off	N	19.6	22.4	64.0
0.206000	40.1	Off	N	19.6	23.3	63.4
0.238000	38.0	Off	N	19.6	24.2	62.2
0.294000	33.5	Off	N	19.6	26.9	60.4
0.390000	27.5	Off	N	19.6	30.6	58.1
0.766000	29.3	Off	N	19.6	26.7	56.0
13.102000	32.8	Off	N	20.3	27.2	60.0
20.798000	34.5	Off	N	20.8	25.5	60.0

Final Result : Average

Frequency (MHz)	Average (dBµV)	Filter	Line	Corr. (dB)	Margin (dB)	Limit (dBµV)
0.158000	22.4	Off	N	19.6	33.2	55.6
0.174000	23.5	Off	N	19.6	31.3	54.8
0.190000	28.0	Off	N	19.6	26.0	54.0
0.206000	23.5	Off	N	19.6	29.9	53.4
0.238000	24.9	Off	N	19.6	27.3	52.2
0.294000	21.9	Off	N	19.6	28.5	50.4
0.390000	22.4	Off	N	19.6	25.7	48.1
0.766000	24.4	Off	N	19.6	21.6	46.0
13.102000	25.5	Off	N	20.3	24.5	50.0
20.798000	27.3	Off	N	20.8	22.7	50.0

3.6 Frequency Stability Measurement

3.6.1 Limit of Frequency Stability

Manufacturers of U-NII devices are responsible for ensuring frequency stability such that an emission is maintained within the band of operation under all conditions of normal operation as specified in the user's manual.

3.6.2 Measuring Instruments

The measuring equipment is listed in the section 4 of this test report.

3.6.3 Test Procedures

1. To ensure emission at the band edge is maintained within the authorized band, those values shall be measured by radiation emissions at upper and lower frequency points, and finally compensated by frequency deviation as procedures below.
2. The EUT was operated at the maximum output power, and connected to the spectrum analyzer, which is set to maximum hold function and peak detector. The peak value of the power envelope was measured and noted. The upper and lower frequency points were respectively measured relatively 10dB lower than the measured peak value.
3. The frequency deviation was calculated by adding the upper frequency point and the lower frequency point divided by two. Those detailed values of frequency deviation are provided in table below.

3.6.4 Test Setup

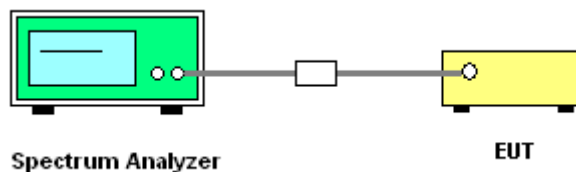

3.6.5 Test Result of Frequency Stability

Please refer to Appendix A.



3.7 Automatically Discontinue Transmission

3.7.1 Limit of Automatically Discontinue Transmission

The device shall automatically discontinue transmission in case of either absence of information to transmit or operational failure. These provisions are not intended to preclude the transmission of control or signaling information or the use of repetitive codes used by certain digital technologies to complete frame or burst intervals. Applicants shall include in their application for equipment authorization to describe how this requirement is met.

3.7.2 Measuring Instruments

The measuring equipment is listed in the section 4 of this test report.

3.7.3 Test Result of Automatically Discontinue Transmission

While the EUT is not transmitting any information, the EUT can automatically discontinue transmission and become standby mode for power saving. The EUT can detect the controlling signal of ACK message transmitting from remote device and verify whether it shall resend or discontinue transmission.



3.8 Antenna Requirements

3.8.1 Standard Applicable

According to FCC 47 CFR Section 15.407(a)(1)(2) ,if transmitting antenna directional gain is greater than 6 dBi, both the peak transmit power and the peak power spectral density shall be reduced by the amount in dB that the directional gain of the antenna exceeds 6 dBi.

3.8.2 Antenna Anti-Replacement Construction

An embedded-in antenna design is used.

3.8.3 Antenna Gain

The antenna gain is less than 6 dBi. Therefore, it is not necessary to reduce maximum peak output power limit.



4 List of Measuring Equipment

Instrument	Manufacturer	Model No.	Serial No.	Characteristics	Calibration Date	Test Date	Due Date	Remark
Power Meter	Anritsu	ML2495A	1132003	300MHz~40GHz	Aug. 12, 2015	May 22, 2016 ~ Jun. 22, 2016	Aug. 11, 2016	Conducted (TH05-HY)
Power Sensor	Anritsu	MA2411B	1126017	300MHz~40GHz	Aug. 12, 2015	May 22, 2016 ~ Jun. 22, 2016	Aug. 11, 2016	Conducted (TH05-HY)
Spectrum Analyzer	Rohde & Schwarz	FSP30	101067	9kHz ~ 30GHz	Nov. 13, 2015	May 22, 2016 ~ Jun. 22, 2016	Nov. 12, 2016	Conducted (TH05-HY)
Temperature Chamber	ESPEC	SH-641	92013720	-40°C ~90°C	Sep. 08, 2015	May 22, 2016 ~ Jun. 22, 2016	Sep. 07, 2016	Conducted (TH05-HY)
Loop Antenna	Rohde & Schwarz	HFH2-Z2	100315	9 kHz~30 MHz	Sep. 02, 2015	Jun. 16, 2016 ~ Jun. 18, 2016	Sep. 01, 2016	Radiation (03CH11-HY)
Amplifier	SONOMA	310N	187312	9kHz~1GHz	Nov. 20, 2015	Jun. 16, 2016 ~ Jun. 18, 2016	Nov. 19, 2016	Radiation (03CH11-HY)
Bilog Antenna	TESEQ	CBL 6111D	35414	30MHz~1GHz	Nov. 17, 2015	Jun. 16, 2016 ~ Jun. 18, 2016	Nov. 16, 2016	Radiation (03CH11-HY)
Horn Antenna	SCHWARZBECK	BBHA 9120 D	9120D-1326	1GHz ~ 18GHz	Oct. 08, 2015	Jun. 16, 2016 ~ Jun. 18, 2016	Oct. 07, 2016	Radiation (03CH11-HY)
Preamplifier	Keysight	83017A	MY53270080	1GHz~26.5GHz	Nov. 19, 2015	Jun. 16, 2016 ~ Jun. 18, 2016	Nov. 18, 2016	Radiation (03CH11-HY)
Preamplifier	MITEQ	AMF-7D-0010 1800-30-10P	1902247	1GHz~18GHz	Jul. 01, 2015	Jun. 16, 2016 ~ Jun. 18, 2016	Jun. 30, 2016	Radiation (03CH11-HY)
Spectrum Analyzer	Keysight	N9010A	MY54200486	10Hz ~ 44GHZ	Sep. 24, 2015	Jun. 16, 2016 ~ Jun. 18, 2016	Sep. 23, 2016	Radiation (03CH11-HY)
Antenna Mast	EMEC	AM-BS-4500-B	N/A	1~4m	N/A	Jun. 16, 2016 ~ Jun. 18, 2016	N/A	Radiation (03CH11-HY)
Turn Table	EMEC	TT 2000	N/A	0~360 Degree	N/A	Jun. 16, 2016 ~ Jun. 18, 2016	N/A	Radiation (03CH11-HY)
SHF-EHF Horn Antenna	SCHWARZBECK	BBHA 9170	BBHA917058 4	18GHz- 40GHz	Nov. 02, 2015	Jun. 16, 2016 ~ Jun. 18, 2016	Nov. 01, 2016	Radiation (03CH11-HY)
Preamplifier	MITEQ	TTA0204	1872107	2GHz~40GHz	Feb. 15, 2016	Jun. 16, 2016 ~ Jun. 18, 2016	Feb. 14, 2017	Radiation (03CH11-HY)
AC Power Source	ChainTek	APC-1000W	N/A	N/A	N/A	May 28, 2016	N/A	Conduction (CO05-HY)
EMI Test Receiver	Rohde & Schwarz	ESCI 7	100724	9kHz~7GHz	Aug. 26, 2015	May 28, 2016	Aug. 25, 2016	Conduction (CO05-HY)
LISN	Rohde & Schwarz	ENV216	100080	9kHz~30MHz	Dec. 02, 2015	May 28, 2016	Dec. 01, 2016	Conduction (CO05-HY)



5 Uncertainty of Evaluation

Uncertainty of Conducted Emission Measurement (150kHz ~ 30MHz)

Measuring Uncertainty for a Level of Confidence of 95% ($U = 2Uc(y)$)	2.26
---	------

Uncertainty of Radiated Emission Measurement (30 MHz ~ 1000 MHz)

Measuring Uncertainty for a Level of Confidence of 95% ($U = 2Uc(y)$)	4.9
---	-----



Appendix A. Conducted Test Results

Test Engineer:	Kenny Chen	Temperature:	21~25	°C
Test Date:	2016/05/22~2016/06/22	Relative Humidity:	51~54	%

TEST RESULTS DATA
6dB and 26dB EBW and 99% OBW

Band IV									
Mod.	Data Rate	NTX	CH.	Freq. (MHz)	99% Bandwidth (MHz)	26 dB Bandwidth (MHz)	6 dB Bandwidth (MHz)	6dB Bandwidth min. Limit (MHz)	Pass/Fail
11a	6M bps	1	149	5745	18.85	44.2	16.32	0.5	Pass
11a	6Mbps	1	157	5785	19.25	42.85	16.32	0.5	Pass
11a	6Mbps	1	165	5825	19	44.55	16.32	0.5	Pass
HT20	MCS 0	1	149	5745	19.35	43.6	17.56	0.5	Pass
HT20	MCS 0	1	157	5785	19.4	45.8	17.56	0.5	Pass
HT20	MCS 0	1	165	5825	19.5	46.55	17.56	0.5	Pass
HT40	MCS 0	1	151	5755	36.7	77.4	35.12	0.5	Pass
HT40	MCS 0	1	159	5795	37.1	82.71	35.12	0.5	Pass

TEST RESULTS DATA
Average Power Table

Band IV										
Mod.	Data Rate	NTX	CH.	Freq. (MHz)	Duty Factor (dB)	Average Conducted Power (dBm)	FCC Conducted Power Limit (dBm)	DG (dBi)		Pass/Fail
11a	6M bps	1	149	5745	0.61	15.80	30.00	0.00		Pass
11a	6Mbps	1	157	5785	0.61	16.22	30.00	0.00		Pass
11a	6Mbps	1	165	5825	0.61	16.34	30.00	0.00		Pass
HT20	MCS 0	1	149	5745	0.63	14.78	30.00	0.00		Pass
HT20	MCS 0	1	157	5785	0.63	15.12	30.00	0.00		Pass
HT20	MCS 0	1	165	5825	0.63	15.32	30.00	0.00		Pass
HT40	MCS 0	1	151	5755	1.21	14.58	30.00	0.00		Pass
HT40	MCS 0	1	159	5795	1.21	14.93	30.00	0.00		Pass

TEST RESULTS DATA
Power Spectral Density

Band IV										
Mod.	Data Rate	NTX	CH.	Freq. (MHz)	Duty Factor (dB)	10log (500kHz /RBW) Factor (dB)	Average Power Density (dBm/500kHz)	Average PSD Limit (dBm/500kHz)	DG (dBi)	Pass/Fail
11a	6M bps	1	149	5745	0.61	2.22	4.89	30.00	0.00	Pass
11a	6Mbps	1	157	5785	0.61	2.22	5.18	30.00	0.00	Pass
11a	6Mbps	1	165	5825	0.61	2.22	5.84	30.00	0.00	Pass
HT20	MCS 0	1	149	5745	0.63	2.22	3.93	30.00	0.00	Pass
HT20	MCS 0	1	157	5785	0.63	2.22	4.06	30.00	0.00	Pass
HT20	MCS 0	1	165	5825	0.63	2.22	4.83	30.00	0.00	Pass
HT40	MCS 0	1	151	5755	1.21	2.22	1.28	30.00	0.00	Pass
HT40	MCS 0	1	159	5795	1.21	2.22	1.51	30.00	0.00	Pass

TEST RESULTS DATA
Frequency Stability

Band IV										
Mod.	Data Rate	NTX	CH.	Freq. (MHz)	Center Frequency (MHz)	Frequency Deviation (MHz)	Frequency Stability (ppm)	Temperature (°C)	Voltage (V)	Note
11a	6M bps	1	149	5745	5745.000	0.000	0.00	20	3.4	
11a	6M bps	1	149	5745	5744.950	-0.050	-8.70	20	4.35	
11a	6M bps	1	149	5745	5745.000	0.000	0.00	20	3.9	
11a	6M bps	1	149	5745	5745.000	0.000	0.00	-30	3.9	
11a	6M bps	1	149	5745	5745.000	0.000	0.00	50	3.9	



Appendix B. Radiated Spurious Emission

Test Engineer :	J.C. Liang, Jacky Su, Ken Wu, and Bill Chang	Temperature :	20~23°C
		Relative Humidity :	50~54%

Band 4 - 5725~5850MHz

WIFI 802.11a (Band Edge @ 3m)

WIFI Ant.	Note	Frequency (MHz)	Level (dBμV/m)	Over Limit (dB)	Limit Line (dBμV/m)	Read Level (dBμV)	Antenna Factor (dB/m)	Cable Loss (dB)	Preamp Factor (dB)	Ant Pos (cm)	Table Pos (deg)	Peak Avg. (P/A)	Pol. (H/V)	
802.11a CH 149 5745MHz		5645	48.96	-19.34	68.3	39.62	32.19	10.69	33.54	311	114	P	H	
		5651.6	47.55	-21.94	69.49	38.18	32.22	10.69	33.54	311	114	P	H	
		5719.8	58.74	-52.1	110.84	49.35	32.31	10.65	33.57	311	114	P	H	
		5723.6	70.15	-48.96	119.11	60.76	32.31	10.65	33.57	311	114	P	H	
		5745	98.9	-	-	89.5	32.34	10.63	33.57	311	114	P	H	
		5745	89.93	-	-	80.53	32.34	10.63	33.57	311	114	A	H	
														H
														H
			5631.4	48.41	-19.89	68.3	39.09	32.17	10.69	33.54	303	46	P	V
			5652	47.7	-22.09	69.79	38.33	32.22	10.69	33.54	303	46	P	V
			5717.6	63.24	-46.99	110.23	53.85	32.31	10.65	33.57	303	46	P	V
			5724.4	70.24	-50.69	120.93	60.85	32.31	10.65	33.57	303	46	P	V
			5745	105.2	-	-	95.8	32.34	10.63	33.57	303	46	P	V
			5745	96.62	-	-	87.22	32.34	10.63	33.57	303	46	A	V
													V	
													V	



WIFI Ant. 1	Note	Frequency (MHz)	Level (dBμV/m)	Over Limit (dB)	Limit Line (dBμV/m)	Read Level (dBμV)	Antenna Factor (dB/m)	Cable Loss (dB)	Preamp Factor (dB)	Ant Pos (cm)	Table Pos (deg)	Peak Avg. (P/A)	Pol. (H/V)
		5604.2	48.49	-19.81	68.3	39.17	32.14	10.71	33.53	284	113	P	H
		5652.4	49.41	-20.67	70.08	40.04	32.22	10.69	33.54	284	113	P	H
		5701	48.5	-57.08	105.58	39.12	32.29	10.65	33.56	284	113	P	H
		5720.4	46.13	-65.68	111.81	36.74	32.31	10.65	33.57	284	113	P	H
		5785	100.06	-	-	90.65	32.39	10.61	33.59	284	113	P	H
		5785	91.51	-	-	82.1	32.39	10.61	33.59	284	113	A	H
		5854.4	48.45	-63.82	112.27	38.77	32.51	10.78	33.61	284	113	P	H
		5872.2	49.11	-56.97	106.08	39.26	32.53	10.94	33.62	284	113	P	H
		5922.8	46.62	-23.3	69.92	36.55	32.6	11.11	33.64	284	113	P	H
		5946.8	48.68	-19.62	68.3	38.43	32.63	11.27	33.65	284	113	P	H
													H
													H
802.11a													
CH 157													
5785MHz		5641.8	48.08	-20.22	68.3	38.74	32.19	10.69	33.54	289	52	P	V
		5650.2	46.72	-21.73	68.45	37.35	32.22	10.69	33.54	289	52	P	V
		5702.2	46.84	-59.08	105.92	37.46	32.29	10.65	33.56	289	52	P	V
		5723	47.37	-70.37	117.74	37.98	32.31	10.65	33.57	289	52	P	V
		5785	106.81	-	-	97.4	32.39	10.61	33.59	289	52	P	V
		5785	97.81	-	-	88.4	32.39	10.61	33.59	289	52	A	V
		5853.4	50.41	-64.14	114.55	40.76	32.48	10.78	33.61	289	52	P	V
		5874.6	48.77	-56.64	105.41	38.92	32.53	10.94	33.62	289	52	P	V
		5923.6	49.39	-19.94	69.33	39.32	32.6	11.11	33.64	289	52	P	V
		5930.6	49.29	-19.01	68.3	39.22	32.6	11.11	33.64	289	52	P	V
													V
													V



WiFi Ant. 1	Note	Frequency (MHz)	Level (dBμV/m)	Over Limit (dB)	Limit Line (dBμV/m)	Read Level (dBμV)	Antenna Factor (dB/m)	Cable Loss (dB)	Preamp Factor (dB)	Ant Pos (cm)	Table Pos (deg)	Peak Avg. (P/A)	Pol. (H/V)	
802.11a CH 165 5825MHz		5825	101.13	-	-	91.49	32.46	10.78	33.6	279	114	P	H	
		5825	92.73	-	-	83.09	32.46	10.78	33.6	279	114	A	H	
		5851.6	59.39	-59.26	118.65	49.74	32.48	10.78	33.61	279	114	P	H	
		5855	58	-52.9	110.9	48.32	32.51	10.78	33.61	279	114	P	H	
		5922.4	49.48	-20.74	70.22	39.41	32.6	11.11	33.64	279	114	P	H	
		5939.4	48.03	-20.27	68.3	37.94	32.63	11.11	33.65	279	114	P	H	
														H
														H
			5825	108.33	-	-	98.69	32.46	10.78	33.6	281	55	P	V
			5825	99.01	-	-	89.37	32.46	10.78	33.6	281	55	A	V
			5850.6	67.1	-53.83	120.93	57.45	32.48	10.78	33.61	281	55	P	V
			5855.6	63.17	-47.56	110.73	53.49	32.51	10.78	33.61	281	55	P	V
			5923.4	48.62	-20.86	69.48	38.55	32.6	11.11	33.64	281	55	P	V
			5934.4	48.83	-19.47	68.3	38.77	32.6	11.11	33.65	281	55	P	V
														V
														V
													V	
Remark	1. No other spurious found. 2. All results are PASS against Peak and Average limit line.													



Band 4 5725~5850MHz

WIFI 802.11a (Harmonic @ 3m)

WIFI Ant. 1	Note	Frequency (MHz)	Level (dBμV/m)	Over Limit (dB)	Limit Line (dBμV/m)	Read Level (dBμV)	Antenna Factor (dB/m)	Cable Loss (dB)	Preamp Factor (dB)	Ant Pos (cm)	Table Pos (deg)	Peak Avg. (P/A)	Pol. (H/V)
802.11a CH 149 5745MHz		11490	42.11	-31.89	74	52.35	39.91	15.59	65.74	100	0	P	H
		17235	41.88	-26.42	68.3	46.36	41	18.6	64.08	100	0	P	H
													H
													H
		11490	43.38	-30.62	74	53.62	39.91	15.59	65.74	100	0	P	V
		17235	42.31	-25.99	68.3	46.79	41	18.6	64.08	100	0	P	V
													V
													V
802.11a CH 157 5785MHz		11570	41.48	-32.52	74	51.74	39.76	15.64	65.66	100	0	P	H
		17355	42.66	-25.64	68.3	46.88	41.35	18.65	64.22	100	0	P	H
													H
													H
		11570	42.21	-31.79	74	52.47	39.76	15.64	65.66	100	0	P	V
		17355	40.83	-27.47	68.3	45.05	41.35	18.65	64.22	100	0	P	V
													V
													V
802.11a CH 165 5825MHz		11650	41.85	-32.15	74	52.16	39.62	15.69	65.62	100	0	P	H
		17475	41	-27.3	68.3	44.96	41.7	18.7	64.36	100	0	P	H
													H
													H
		11650	43.54	-30.46	74	53.85	39.62	15.69	65.62	100	0	P	V
		17475	41.52	-26.78	68.3	45.48	41.7	18.7	64.36	100	0	P	V
													V
													V
Remark	1. No other spurious found. 2. All results are PASS against Peak and Average limit line.												



Band 4 5725~5850MHz
WIFI 802.11n HT20 (Band Edge @ 3m)

WIFI Ant. 1	Note	Frequency (MHz)	Level (dBμV/m)	Over Limit (dB)	Limit Line (dBμV/m)	Read Level (dBμV)	Antenna Factor (dB/m)	Cable Loss (dB)	Preamp Factor (dB)	Ant Pos (cm)	Table Pos (deg)	Peak Avg. (P/A)	Pol. (H/V)	
802.11n HT20 CH 149 5745MHz		5648.6	48.58	-19.72	68.3	39.24	32.19	10.69	33.54	369	119	P	H	
		5675.2	47.7	-39.29	86.99	38.34	32.24	10.67	33.55	369	119	P	H	
		5719	52.63	-57.99	110.62	43.24	32.31	10.65	33.57	369	119	P	H	
		5724	62.17	-57.85	120.02	52.78	32.31	10.65	33.57	369	119	P	H	
		5752	97.76	-	-	88.34	32.36	10.63	33.57	369	119	P	H	
		5752	89.96	-	-	80.54	32.36	10.63	33.57	369	119	A	H	
														H
														H
			5628.6	48.5	-19.8	68.3	39.18	32.17	10.69	33.54	303	55	P	V
			5690.2	50.75	-47.32	98.07	41.37	32.27	10.67	33.56	303	55	P	V
			5718.6	60.28	-50.23	110.51	50.89	32.31	10.65	33.57	303	55	P	V
			5724.6	66.46	-54.93	121.39	57.07	32.31	10.65	33.57	303	55	P	V
			5752	104.73	-	-	95.31	32.36	10.63	33.57	303	55	P	V
			5752	96.29	-	-	86.87	32.36	10.63	33.57	303	55	A	V
													V	
													V	



WIFI Ant. 1	Note	Frequency (MHz)	Level (dBμV/m)	Over Limit (dB)	Limit Line (dBμV/m)	Read Level (dBμV)	Antenna Factor (dB/m)	Cable Loss (dB)	Preamp Factor (dB)	Ant Pos (cm)	Table Pos (deg)	Peak Avg. (P/A)	Pol. (H/V)
		5603.2	49.3	-19	68.3	39.98	32.14	10.71	33.53	345	117	P	H
		5688.6	48.63	-48.26	96.89	39.25	32.27	10.67	33.56	345	117	P	H
		5712	46.63	-62.03	108.66	37.26	32.29	10.65	33.57	345	117	P	H
		5721	47.3	-65.88	113.18	37.91	32.31	10.65	33.57	345	117	P	H
		5785	96.44	-	-	87.03	32.39	10.61	33.59	345	117	P	H
		5785	88.39	-	-	78.98	32.39	10.61	33.59	345	117	A	H
		5850.4	48.02	-73.37	121.39	38.37	32.48	10.78	33.61	345	117	P	H
		5862.4	49.05	-59.78	108.83	39.22	32.51	10.94	33.62	345	117	P	H
		5881.6	48.62	-51.78	100.4	38.77	32.53	10.94	33.62	345	117	P	H
		5948.8	49.02	-19.28	68.3	38.77	32.63	11.27	33.65	345	117	P	H
													H
													H
802.11n													
HT20													
CH 157		5646.8	48.26	-20.04	68.3	38.92	32.19	10.69	33.54	350	50	P	V
5785MHz		5682.2	48.27	-43.9	92.17	38.92	32.24	10.67	33.56	350	50	P	V
		5704.6	48.4	-58.19	106.59	39.02	32.29	10.65	33.56	350	50	P	V
		5725	48.41	-73.89	122.3	39.02	32.31	10.65	33.57	350	50	P	V
		5785	102.43	-	-	93.02	32.39	10.61	33.59	350	50	P	V
		5785	94.08	-	-	84.67	32.39	10.61	33.59	350	50	A	V
		5854.6	48.25	-63.56	111.81	38.57	32.51	10.78	33.61	350	50	P	V
		5863.2	48.23	-60.37	108.6	38.4	32.51	10.94	33.62	350	50	P	V
		5887.4	48.87	-47.22	96.09	39.03	32.53	10.94	33.63	350	50	P	V
		5944.8	49.44	-18.86	68.3	39.19	32.63	11.27	33.65	350	50	P	V
													V
													V



WIFI Ant. 1	Note	Frequency (MHz)	Level (dBμV/m)	Over Limit (dB)	Limit Line (dBμV/m)	Read Level (dBμV)	Antenna Factor (dB/m)	Cable Loss (dB)	Preamp Factor (dB)	Ant Pos (cm)	Table Pos (deg)	Peak Avg. (P/A)	Pol. (H/V)	
802.11n HT20 CH 165 5825MHz		5825	98.02	-	-	88.38	32.46	10.78	33.6	308	118	P	H	
		5825	89.74	-	-	80.1	32.46	10.78	33.6	308	118	A	H	
		5850.4	61.21	-60.18	121.39	51.56	32.48	10.78	33.61	308	118	P	H	
		5858.6	52.86	-57.03	109.89	43.19	32.51	10.78	33.62	308	118	P	H	
		5902.8	50.15	-34.54	84.69	40.11	32.56	11.11	33.63	308	118	P	H	
		5942.2	48.61	-19.69	68.3	38.36	32.63	11.27	33.65	308	118	P	H	
														H
														H
			5825	104.46	-	-	94.82	32.46	10.78	33.6	284	52	P	V
			5825	96.13	-	-	86.49	32.46	10.78	33.6	284	52	A	V
			5850	62.85	-59.45	122.3	53.2	32.48	10.78	33.61	284	52	P	V
			5855.6	60.29	-50.44	110.73	50.61	32.51	10.78	33.61	284	52	P	V
			5879.4	52.06	-49.97	102.03	42.21	32.53	10.94	33.62	284	52	P	V
			5938.2	48.34	-19.96	68.3	38.28	32.6	11.11	33.65	284	52	P	V
														V
													V	
Remark	1. No other spurious found. 2. All results are PASS against Peak and Average limit line.													



Band 4 5725~5850MHz
WIFI 802.11n HT20 (Harmonic @ 3m)

WIFI Ant. 1	Note	Frequency (MHz)	Level (dBμV/m)	Over Limit (dB)	Limit Line (dBμV/m)	Read Level (dBμV)	Antenna Factor (dB/m)	Cable Loss (dB)	Preamp Factor (dB)	Ant Pos (cm)	Table Pos (deg)	Peak Avg. (P/A)	Pol. (H/V)	
802.11n HT20 CH 149 5745MHz		11490	42.36	-31.64	74	52.6	39.91	15.59	65.74	100	0	P	H	
		17235	41.84	-26.46	68.3	46.32	41	18.6	64.08	100	0	P	H	
													H	
													H	
			11490	43.24	-30.76	74	53.48	39.91	15.59	65.74	100	0	P	V
			17235	42.79	-25.51	68.3	47.27	41	18.6	64.08	100	0	P	V
														V
802.11n HT20 CH 157 5785MHz		11570	41.51	-32.49	74	51.77	39.76	15.64	65.66	100	0	P	H	
		17355	40.83	-27.47	68.3	45.05	41.35	18.65	64.22	100	0	P	H	
													H	
													H	
			11570	43.47	-30.53	74	53.73	39.76	15.64	65.66	100	0	P	V
			17355	41.95	-26.35	68.3	46.17	41.35	18.65	64.22	100	0	P	V
														V
802.11n HT20 CH 165 5825MHz		11650	41.51	-32.49	74	51.82	39.62	15.69	65.62	100	0	P	H	
		17475	41.43	-26.87	68.3	45.39	41.7	18.7	64.36	100	0	P	H	
													H	
													H	
			11650	43.05	-30.95	74	53.36	39.62	15.69	65.62	100	0	P	V
			17475	42.44	-25.86	68.3	46.4	41.7	18.7	64.36	100	0	P	V
														V
Remark	1. No other spurious found.													
	2. All results are PASS against Peak and Average limit line.													



Band 4 5725~5850MHz
WIFI 802.11n HT40 (Band Edge @ 3m)

WIFI Ant. 1	Note	Frequency (MHz)	Level (dBμV/m)	Over Limit (dB)	Limit Line (dBμV/m)	Read Level (dBμV)	Antenna Factor (dB/m)	Cable Loss (dB)	Preamp Factor (dB)	Ant Pos (cm)	Table Pos (deg)	Peak Avg. (P/A)	Pol. (H/V)
		5611	48.6	-19.7	68.3	39.28	32.14	10.71	33.53	389	114	P	H
		5693.2	49.6	-50.69	100.29	40.22	32.27	10.67	33.56	389	114	P	H
		5719.6	59.88	-50.91	110.79	50.49	32.31	10.65	33.57	389	114	P	H
		5724.6	63.77	-57.62	121.39	54.38	32.31	10.65	33.57	389	114	P	H
		5755	93.47	-	-	84.05	32.36	10.63	33.57	389	114	P	H
		5755	85.13	-	-	75.71	32.36	10.63	33.57	389	114	A	H
		5852	47.09	-70.65	117.74	37.44	32.48	10.78	33.61	389	114	P	H
		5865.2	48.41	-59.63	108.04	38.58	32.51	10.94	33.62	389	114	P	H
		5919.2	50.45	-22.13	72.58	40.4	32.58	11.11	33.64	389	114	P	H
		5948.4	48.99	-19.31	68.3	38.74	32.63	11.27	33.65	389	114	P	H
													H
													H
802.11n HT40 CH 151 5755MHz		5628.8	48.47	-19.83	68.3	39.15	32.17	10.69	33.54	292	54	P	V
		5691.6	55.26	-43.85	99.11	45.88	32.27	10.67	33.56	292	54	P	V
		5719.4	70.66	-40.07	110.73	61.27	32.31	10.65	33.57	292	54	P	V
		5720.8	74.28	-38.44	112.72	64.89	32.31	10.65	33.57	292	54	P	V
		5755	99.86	-	-	90.44	32.36	10.63	33.57	292	54	P	V
		5755	91.4	-	-	81.98	32.36	10.63	33.57	292	54	A	V
		5852.4	48.33	-68.5	116.83	38.68	32.48	10.78	33.61	292	54	P	V
		5861	50.27	-58.95	109.22	40.44	32.51	10.94	33.62	292	54	P	V
		5907	48.8	-32.78	81.58	38.74	32.58	11.11	33.63	292	54	P	V
		5926.4	48.65	-19.65	68.3	38.58	32.6	11.11	33.64	292	54	P	V
													V
													V



WIFI Ant. 1	Note	Frequency (MHz)	Level (dBμV/m)	Over Limit (dB)	Limit Line (dBμV/m)	Read Level (dBμV)	Antenna Factor (dB/m)	Cable Loss (dB)	Preamp Factor (dB)	Ant Pos (cm)	Table Pos (deg)	Peak Avg. (P/A)	Pol. (H/V)
		5634.2	49.12	-19.18	68.3	39.78	32.19	10.69	33.54	283	119	P	H
		5651.6	48.64	-20.85	69.49	39.27	32.22	10.69	33.54	283	119	P	H
		5719.4	48.86	-61.87	110.73	39.47	32.31	10.65	33.57	283	119	P	H
		5721.2	48.04	-65.6	113.64	38.65	32.31	10.65	33.57	283	119	P	H
		5795	94.16	-	-	84.73	32.41	10.61	33.59	283	119	P	H
		5795	86.38	-	-	76.95	32.41	10.61	33.59	283	119	A	H
		5854.4	49.33	-62.94	112.27	39.65	32.51	10.78	33.61	283	119	P	H
		5857.6	51.64	-58.53	110.17	41.96	32.51	10.78	33.61	283	119	P	H
		5890.2	49.39	-44.63	94.02	39.52	32.56	10.94	33.63	283	119	P	H
		5946.4	48.67	-19.63	68.3	38.42	32.63	11.27	33.65	283	119	P	H
													H
													H
802.11n													
HT40													
CH 159		5636.6	48.57	-19.73	68.3	39.23	32.19	10.69	33.54	289	48	P	V
5795MHz		5694	49.27	-51.61	100.88	39.89	32.27	10.67	33.56	289	48	P	V
		5716	49.81	-59.97	109.78	40.44	32.29	10.65	33.57	289	48	P	V
		5722.8	51.53	-65.75	117.28	42.14	32.31	10.65	33.57	289	48	P	V
		5795	101.45	-	-	92.02	32.41	10.61	33.59	289	48	P	V
		5795	92.94	-	-	83.51	32.41	10.61	33.59	289	48	A	V
		5852	55.01	-62.73	117.74	45.36	32.48	10.78	33.61	289	48	P	V
		5856.4	54.06	-56.45	110.51	44.38	32.51	10.78	33.61	289	48	P	V
		5924.8	50.66	-17.79	68.45	40.59	32.6	11.11	33.64	289	48	P	V
		5928.8	49.34	-18.96	68.3	39.27	32.6	11.11	33.64	289	48	P	V
													V
													V
Remark	1. No other spurious found. 2. All results are PASS against Peak and Average limit line.												



Band 4 5725~5850MHz
WIFI 802.11n HT40 (Harmonic @ 3m)

WIFI Ant. 1	Note	Frequency (MHz)	Level (dBμV/m)	Over Limit (dB)	Limit Line (dBμV/m)	Read Level (dBμV)	Antenna Factor (dB/m)	Cable Loss (dB)	Preamp Factor (dB)	Ant Pos (cm)	Table Pos (deg)	Peak Avg. (P/A)	Pol. (H/V)
802.11n HT40 CH 151 5755MHz		11510	42.62	-31.38	74	52.81	39.9	15.61	65.7	100	0	P	H
		17265	42.15	-26.15	68.3	46.55	41.1	18.62	64.12	100	0	P	H
													H
													H
		11510	42.75	-31.25	74	52.94	39.9	15.61	65.7	100	0	P	V
		17265	41.25	-27.05	68.3	45.65	41.1	18.62	64.12	100	0	P	V
													V
													V
802.11n HT40 CH 159 5795MHz		11590	42.32	-31.68	74	52.58	39.73	15.66	65.65	100	0	P	H
		17385	42.35	-25.95	68.3	46.5	41.45	18.66	64.26	100	0	P	H
													H
													H
		11590	43.52	-30.48	74	53.78	39.73	15.66	65.65	100	0	P	V
		17385	41.97	-26.33	68.3	46.12	41.45	18.66	64.26	100	0	P	V
													V
													V
Remark	1. No other spurious found. 2. All results are PASS against Peak and Average limit line.												



Band 4 5725~5850MHz

Emission below 1GHz

5GHz WIFI 802.11a (LF @ 3m)

WIFI Ant.	Note	Frequency	Level	Over Limit	Limit Line	Read Level	Antenna Factor	Cable Loss	Preamp Factor	Ant Pos	Table Pos	Peak Avg.	Pol.	
1		(MHz)	(dBμV/m)	(dB)	(dBμV/m)	(dBμV)	(dB/m)	(dB)	(dB)	(cm)	(deg)	(P/A)	(H/V)	
5GHz 802.11a LF		91.83	27.65	-15.85	43.5	43.12	15.14	1.17	31.78			P	H	
		132.06	39.8	-3.7	43.5	52.12	17.98	1.48	31.78	155	55	P	H	
		226.56	30.36	-15.64	46	43.46	16.69	1.98	31.77			P	H	
		485.5	25.27	-20.73	46	30.42	23.87	2.86	31.88			P	H	
		696.2	28.92	-17.08	46	30.85	26.66	3.45	32.04			P	H	
		936.3	33.74	-12.26	46	30.81	30.22	3.86	31.15			P	H	
														H
														H
														H
														H
														H
														H
			34.59	36.77	-3.23	40	44.57	23.1	0.93	31.83	125	40	P	V
			131.25	35.4	-8.1	43.5	47.71	17.99	1.48	31.78			P	V
			223.59	32.32	-13.68	46	45.64	16.48	1.98	31.78			P	V
			420.4	24.49	-21.51	46	29.87	22.76	3.68	31.82			P	V
			593.3	27.19	-18.81	46	30.48	25.58	3.16	32.03			P	V
			843.9	31.46	-14.54	46	30.56	28.83	3.77	31.7			P	V
														V
														V
													V	
													V	
													V	
													V	
Remark	1. No other spurious found. 2. All results are PASS against limit line.													



Note symbol

*	Fundamental Frequency which can be ignored. However, the level of any unwanted emissions shall not exceed the level of the fundamental frequency.
!	Test result is over limit line.
P/A	Peak or Average
H/V	Horizontal or Vertical



A calculation example for radiated spurious emission is shown as below:

WIFI	Note	Frequency	Level	Over	Limit	Read	Antenna	Cable	Preamp	Ant	Table	Peak	Pol.
Ant.				Limit	Line	Level	Factor	Loss	Factor	Pos	Pos	Avg.	
1		(MHz)	(dBμV/m)	(dB)	(dBμV/m)	(dBμV)	(dB/m)	(dB)	(dB)	(cm)	(deg)	(P/A)	(H/V)
802.11b		2390	55.45	-18.55	74	54.51	32.22	4.58	35.86	103	308	P	H
CH 01													
2412MHz		2390	43.54	-10.46	54	42.6	32.22	4.58	35.86	103	308	A	H

- Level(dBμV/m) =
Antenna Factor(dB/m) + Cable Loss(dB) + Read Level(dBμV) - Preamp Factor(dB)
- Over Limit(dB) = Level(dBμV/m) – Limit Line(dBμV/m)

For Peak Limit @ 2390MHz:

- Level(dBμV/m)
= Antenna Factor(dB/m) + Cable Loss(dB) + Read Level(dBμV) - Preamp Factor(dB)
= 32.22(dB/m) + 4.58(dB) + 54.51(dBμV) – 35.86 (dB)
= 55.45 (dBμV/m)
- Over Limit(dB)
= Level(dBμV/m) – Limit Line(dBμV/m)
= 55.45(dBμV/m) – 74(dBμV/m)
= -18.55(dB)

For Average Limit @ 2390MHz:

- Level(dBμV/m)
= Antenna Factor(dB/m) + Cable Loss(dB) + Read Level(dBμV) - Preamp Factor(dB)
= 32.22(dB/m) + 4.58(dB) + 42.6(dBμV) – 35.86 (dB)
= 43.54 (dBμV/m)
- Over Limit(dB)
= Level(dBμV/m) – Limit Line(dBμV/m)
= 43.54(dBμV/m) – 54(dBμV/m)
= -10.46(dB)

Both peak and average measured complies with the limit line, so test result is “PASS”.



Appendix C. Radiated Spurious Emission Plots

Band 4 - 5725~5850MHz
WIFI 802.11a (Band Edge @ 3m)

WIFI	Band 4 5725~5850MHz Band Edge @ 3m	
ANT	802.11a CH149 5745MHz	
1	Horizontal	Fundamental
<p>Peak</p>	<p>Date: 2016-06-16 FCC PART 15E_BAND4_N</p> <p>Site : 03CH11-HY Condition : FCC PART 15E_BAND4_N 3m HORN 91200-HF HORIZONTAL Detector : Peak Project : 651612 Mode : 26</p>	<p>Date: 2016-06-16 FCC PART 15E_BAND4_N</p> <p>Site : 03CH11-HY Condition : FCC PART 15E_BAND4_N 3m HORN 91200-HF HORIZONTAL Detector : Peak Project : 651612 Mode : 26</p>



WIFI	Band 4 5725~5850MHz Band Edge @ 3m	
ANT	802.11a CH149 5745MHz	
1	Vertical	Fundamental
Peak	<p style="font-size: small;">Date: 2016-06-16 FCC PART 15E_BAND4_N</p> <p style="font-size: x-small;">Site : 03CH11-HY Condition : FCC PART 15E_BAND4_N 3m HORN 9120D-HF VERTICAL Detector : Peak Project : 651612 Mode : Z6</p>	<p style="font-size: small;">Date: 2016-06-16 FCC PART 15E_BAND4_N</p> <p style="font-size: x-small;">Site : 03CH11-HY Condition : FCC PART 15E_BAND4_N 3m HORN 9120D-HF VERTICAL Detector : Peak Project : 651612 Mode : Z6</p>



WIFI	Band 4 5725~5850MHz Band Edge @ 3m	
ANT	802.11a CH157 5785MHz	
1	Horizontal	Fundamental
Peak	<p>Date: 2016-06-16</p> <p>Site : 03CH11-HY Condition : FCC PART 15E_BAND4_N 3m HORN 9120D-HF HORIZONTAL Detector : Peak Project : 651612 Mode : Z7</p>	<p>Date: 2016-06-16</p> <p>Site : 03CH11-HY Condition : FCC PART 15E_BAND4_N 3m HORN 9120D-HF HORIZONTAL Detector : Peak Project : 651612 Mode : Z7</p>
Peak	<p>Date: 2016-06-16</p> <p>Site : 03CH11-HY Condition : FCC PART 15E_BAND4_N 3m HORN 9120D-HF HORIZONTAL Detector : Peak Project : 651612 Mode : Z7</p>	



WIFI	Band 4 5725~5850MHz Band Edge @ 3m	
ANT	802.11a CH157 5785MHz	
1	Vertical	Fundamental
Peak	<p>Site : 03CH11-HY Condition : FCC PART 15E_BAND4_N 3m HORN 9120D-HF VERTICAL Detector : Peak Project : 651612 Mode : Z7</p>	<p>Site : 03CH11-HY Condition : FCC PART 15E_BAND4_N 3m HORN 9120D-HF VERTICAL Detector : Peak Project : 651612 Mode : Z7</p>
Peak	<p>Site : 03CH11-HY Condition : FCC PART 15E_BAND4_N 3m HORN 9120D-HF VERTICAL Detector : Peak Project : 651612 Mode : Z7</p>	



WIFI	Band 4 5725~5850MHz Band Edge @ 3m	
ANT	802.11a CH165 5825MHz	
1	Horizontal	Fundamental
Peak	<p>Site : 03CH11-HY Condition : FCC PART 15E_BAND4_N 3m HORN 9120D-HF HORIZONTAL Detector : Peak Project : 651612 Mode : Z8</p>	<p>Site : 03CH11-HY Condition : FCC PART 15E_BAND4_N 3m HORN 9120D-HF HORIZONTAL Detector : Peak Project : 651612 Mode : Z8</p>



WIFI	Band 4 5725~5850MHz Band Edge @ 3m	
ANT	802.11a CH165 5825MHz	
1	Vertical	Fundamental
Peak	<p>Date: 2016-06-16</p> <p>Site : 03CH11-HY Condition : FCC PART 15E_BAND4_N 3m HORN 9120D-HF VERTICAL Detector : Peak Project : 651612 Mode : Z8</p>	<p>Date: 2016-06-16</p> <p>Site : 03CH11-HY Condition : FCC PART 15E_BAND4_N 3m HORN 9120D-HF VERTICAL Detector : Peak Project : 651612 Mode : Z8</p>



**Band 4 5725~5850MHz
WIFI 802.11n HT20 (Band Edge @ 3m)**

WIFI	Band 4 5725~5850MHz Band Edge @ 3m	
ANT	802.11n HT20 CH149 5745MHz	
1	Horizontal	Fundamental
Peak	<p>Date: 2016-06-17</p> <p>Site : 03CH11-HY Condition : FCC PART 15E_BAND4_N 3m HORN 9120D-HF HORIZONTAL RBW:1000.000KHz VBW:3000.000KHz SWT:Auto Detector : Peak Project : 651612 Mode : 29</p>	<p>Date: 2016-06-17</p> <p>Site : 03CH11-HY Condition : FCC PART 15E_BAND4_N 3m HORN 9120D-HF HORIZONTAL RBW:1000.000KHz VBW:3000.000KHz SWT:Auto Detector : Peak Project : 651612 Mode : 29</p>

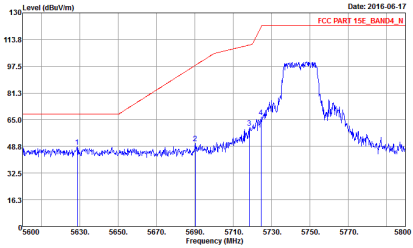
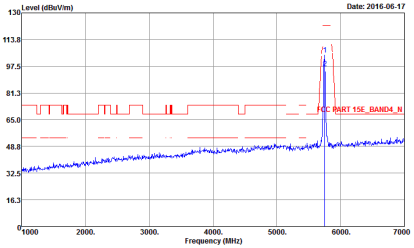

WIFI	Band 4 5725~5850MHz Band Edge @ 3m	
ANT	802.11n HT20 CH149 5745MHz	
1	Vertical	Fundamental
Peak	 <p>Date: 2016-06-17</p> <p>Site : 03CH11-HY Condition : FCC PART 15E_BAND4_N 3m HORN 9120D-HF VERTICAL Detector : Peak Project : 651612 Mode : Z9</p>	 <p>Date: 2016-06-17</p> <p>Site : 03CH11-HY Condition : FCC PART 15E_BAND4_N 3m HORN 9120D-HF VERTICAL Detector : Peak Project : 651612 Mode : Z9</p>



WIFI	Band 4 5725~5850MHz Band Edge @ 3m	
ANT	802.11n HT20 CH165 5825MHz	
1	Horizontal	Fundamental
<p>Peak</p>	<p>Site : 03CH11-HY Condition : FCC PART 15E_BAND4_N 3m HORN 9120D-HF HORIZONTAL Detector : Peak Project : 651612 Mode : 31</p>	<p>Site : 03CH11-HY Condition : FCC PART 15E_BAND4_N 3m HORN 9120D-HF HORIZONTAL Detector : Peak Project : 651612 Mode : 31</p>



WIFI	Band 4 5725~5850MHz Band Edge @ 3m	
ANT	802.11n HT20 CH165 5825MHz	
1	Vertical	Fundamental
Peak	<p>Date: 2016-06-17</p> <p>Site : 03CH11-HY Condition : FCC PART 15E_BAND4_N 3m HORN 9120D-HF VERTICAL Detector : Peak Project : 651612 Mode : 31</p>	<p>Date: 2016-06-17</p> <p>Site : 03CH11-HY Condition : FCC PART 15E_BAND4_N 3m HORN 9120D-HF VERTICAL Detector : Peak Project : 651612 Mode : 31</p>

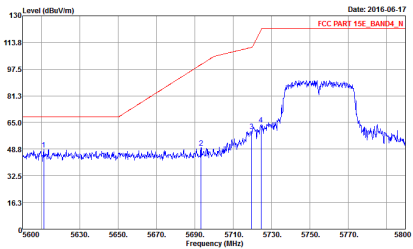
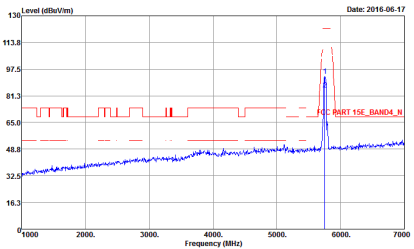
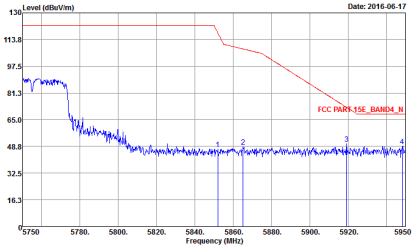

**Band 4 5725~5850MHz
WIFI 802.11n HT40 (Band Edge @ 3m)**

WIFI	Band 4 5725~5850MHz Band Edge @ 3m	
ANT	802.11n HT40 CH151 5755MHz	
1	<p align="center">Horizontal</p>  <p>Date: 2016-06-17 FCC PART 15E_BAND4_N</p> <p>Site : 03CH11-HY Condition : FCC PART 15E_BAND4_N 3m HORN 9120D-HF HORIZONTAL RBW:1000.000KHz VBW:3000.000KHz SWT:Auto Detector : Peak Project : 651612 Mode : 32</p>	<p align="center">Fundamental</p>  <p>Date: 2016-06-17 FCC PART 15E_BAND4_N</p> <p>Site : 03CH11-HY Condition : FCC PART 15E_BAND4_N 3m HORN 9120D-HF HORIZONTAL RBW:1000.000KHz VBW:3000.000KHz SWT:Auto Detector : Peak Project : 651612 Mode : 32</p>
Peak	 <p>Date: 2016-06-17 FCC PART 15E_BAND4_N</p> <p>Site : 03CH11-HY Condition : FCC PART 15E_BAND4_N 3m HORN 9120D-HF HORIZONTAL RBW:1000.000KHz VBW:3000.000KHz SWT:Auto Detector : Peak Project : 651612 Mode : 32</p>	



WIFI	Band 4 5725~5850MHz Band Edge @ 3m	
ANT	802.11n HT40 CH151 5755MHz	
1	Vertical	Fundamental
Peak	<p>Date: 2016-06-17</p> <p>Site : 03CH11-HY Condition : FCC PART 15E_BAND4_N 3m HORN 9120D-HF VERTICAL Detector : Peak Project : 651612 Mode : 32</p>	<p>Date: 2016-06-17</p> <p>Site : 03CH11-HY Condition : FCC PART 15E_BAND4_N 3m HORN 9120D-HF VERTICAL Detector : Peak Project : 651612 Mode : 32</p>
Peak	<p>Date: 2016-06-17</p> <p>Site : 03CH11-HY Condition : FCC PART 15E_BAND4_N 3m HORN 9120D-HF VERTICAL Detector : Peak Project : 651612 Mode : 32</p>	



WIFI	Band 4 5725~5850MHz Band Edge @ 3m	
ANT	802.11n HT40 CH159 5795MHz	
1	Horizontal	Fundamental
Peak	<p>Date: 2016-06-17</p> <p>Site : 03CH11-HY Condition : FCC PART 15E_BAND4_N 3m HORN 9120D-HF HORIZONTAL Detector : Peak Project : 651612 Mode : 33</p>	<p>Date: 2016-06-17</p> <p>Site : 03CH11-HY Condition : FCC PART 15E_BAND4_N 3m HORN 9120D-HF HORIZONTAL Detector : Peak Project : 651612 Mode : 33</p>
Peak	<p>Date: 2016-06-17</p> <p>Site : 03CH11-HY Condition : FCC PART 15E_BAND4_N 3m HORN 9120D-HF HORIZONTAL Detector : Peak Project : 651612 Mode : 33</p>	

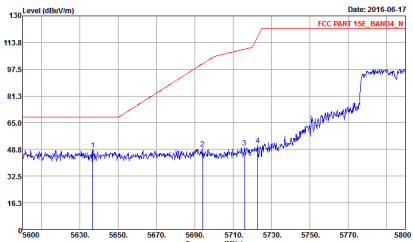
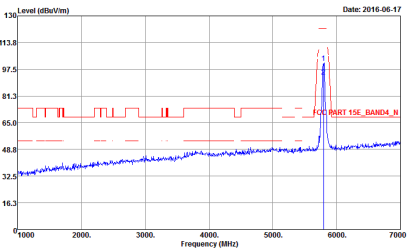
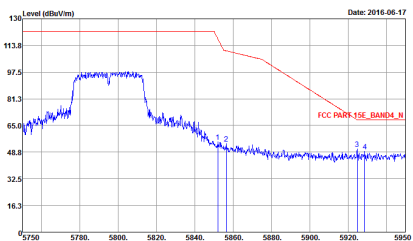

WIFI	Band 4 5725~5850MHz Band Edge @ 3m	
ANT	802.11n HT40 CH159 5795MHz	
1	Vertical	Fundamental
Peak	 <p>Date: 2016-06-17</p> <p>Site : 03CH11-HY Condition : FCC PART 15E_BAND4_N 3m HORN 9120D-HF VERTICAL Detector : Peak Project : 651612 Mode : 33</p>	 <p>Date: 2016-06-17</p> <p>Site : 03CH11-HY Condition : FCC PART 15E_BAND4_N 3m HORN 9120D-HF VERTICAL Detector : Peak Project : 651612 Mode : 33</p>
Peak	 <p>Date: 2016-06-17</p> <p>Site : 03CH11-HY Condition : FCC PART 15E_BAND4_N 3m HORN 9120D-HF VERTICAL Detector : Peak Project : 651612 Mode : 33</p>	



**Band 4 - 5725~5850MHz
WIFI 802.11a (Harmonic @ 3m)**

WIFI	Band 4 5725~5850MHz Harmonic @ 3m	
ANT	802.11a CH149 5745MHz	
1	Horizontal	Vertical
<p>Peak Avg.</p>	<p>Site : 03CH11-HY Condition : FCC PART 15E_BAND4_N 3m 9170 SHF HORM_150809 HORIZONTAL Detector : Peak Project : 651612 Mode : 26</p>	<p>Site : 03CH11-HY Condition : FCC PART 15E_BAND4_N 3m 9170 SHF HORM_150809 VERTICAL Detector : Peak Project : 651612 Mode : 26</p>

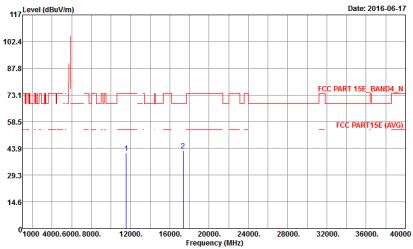
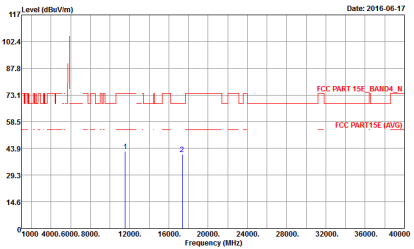

WIFI	Band 4 5725~5850MHz Harmonic @ 3m	
ANT	802.11a CH157 5785MHz	
1	Horizontal	Vertical
<p>Peak</p> <p>Avg.</p>	 <p>Date: 2016-06-17</p> <p>Site : 03CH11-HY Condition : FCC PART 15E_BAND4_N 3m 9170 SHF HORM_150809 HORIZONTAL Detector : Peak Project : 651612 Mode : 27</p>	 <p>Date: 2016-06-17</p> <p>Site : 03CH11-HY Condition : FCC PART 15E_BAND4_N 3m 9170 SHF HORM_150809 VERTICAL Detector : Peak Project : 651612 Mode : 27</p>

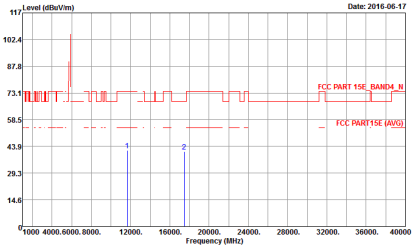
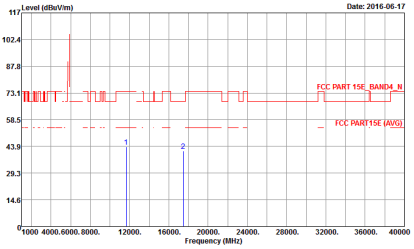

WIFI	Band 4 5725~5850MHz Harmonic @ 3m	
ANT	802.11a CH165 5825MHz	
1	Horizontal	Vertical
<p>Peak</p> <p>Avg.</p>	 <p>Site : 03CH11-HY Condition : FCC PART 15E_BAND4_N 3m 9170 SHF HORN_150809 HORIZONTAL Detector : Peak Project : 651612 Mode : 28</p>	 <p>Site : 03CH11-HY Condition : FCC PART 15E_BAND4_N 3m 9170 SHF HORN_150809 VERTICAL Detector : Peak Project : 651612 Mode : 28</p>

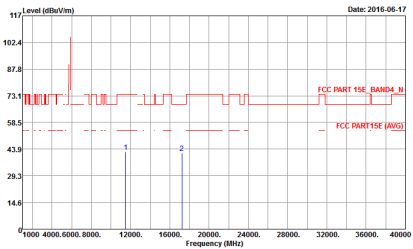
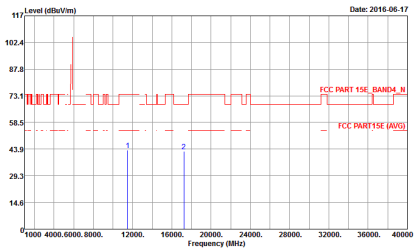

**Band 4 5725~5850MHz
WIFI 802.11n HT20 (Harmonic @ 3m)**

WIFI	Band 4 5725~5850MHz Harmonic @ 3m	
ANT	802.11n HT20 CH149 5745MHz	
1	Horizontal	Vertical
<p>Peak</p> <p>Avg.</p>	 <p>Date: 2016-06-17</p> <p>Site : 02CH11-HY Condition : FCC PART 15E_BAND4_N 3m 9170 SHF HORM_150809 HORIZONTAL Detector : Peak Project : 651612 Mode : 29</p>	 <p>Date: 2016-06-17</p> <p>Site : 02CH11-HY Condition : FCC PART 15E_BAND4_N 3m 9170 SHF HORM_150809 VERTICAL Detector : Peak Project : 651612 Mode : 29</p>

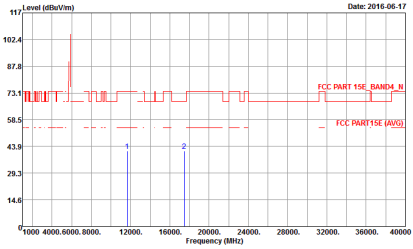
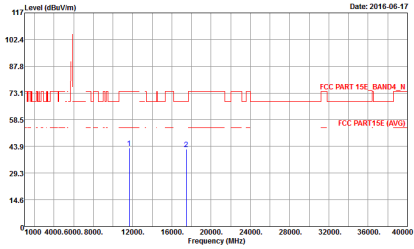

WIFI	Band 4 5725~5850MHz Harmonic @ 3m	
ANT	802.11n HT20 CH165 5825MHz	
1	Horizontal	Vertical
<p>Peak</p> <p>Avg.</p>	 <p>Site : 03CH11-HY Condition : FCC PART 15E_BAND4_N 3m 9170 SHF HORM_150809 HORIZONTAL Detector : Peak Project : 651612 Mode : 31</p>	 <p>Site : 03CH11-HY Condition : FCC PART 15E_BAND4_N 3m 9170 SHF HORM_150809 VERTICAL Detector : Peak Project : 651612 Mode : 31</p>



**Band 4 5725~5850MHz
WIFI 802.11n HT40 (Harmonic @ 3m)**

WIFI	Band 4 5725~5850MHz Harmonic @ 3m	
ANT	802.11n HT40 CH151 5755MHz	
1	Horizontal	Vertical
<p>Peak</p> <p>Avg.</p>	<p>Date: 2016-06-17</p> <p>Site : 02CH11-HY Condition : FCC.PART.15E_BAND4_N 3m 9170 SHF HORM_150809 HORIZONTAL Detector : Peak Project : 651612 Mode : 32</p>	<p>Date: 2016-06-17</p> <p>Site : 02CH11-HY Condition : FCC.PART.15E_BAND4_N 3m 9170 SHF HORM_150809 VERTICAL Detector : Peak Project : 651612 Mode : 32</p>



WIFI	Band 4 5725~5850MHz Harmonic @ 3m	
ANT	802.11n HT40 CH159 5795MHz	
1	Horizontal	Vertical
Peak Avg.	<p>Site : 03CH11-HY Condition : FCC PART 15E_BAND4_N 3m 9170 SHF HORM_150809 HORIZONTAL Detector : Peak Project : 651612 Mode : 33</p>	<p>Site : 03CH11-HY Condition : FCC PART 15E_BAND4_N 3m 9170 SHF HORM_150809 VERTICAL Detector : Peak Project : 651612 Mode : 33</p>



Band 4 5725~5850MHz

Emission below 1GHz

5GHz WIFI 802.11a (LF)

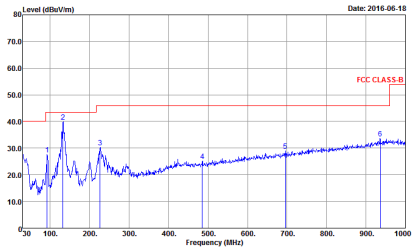
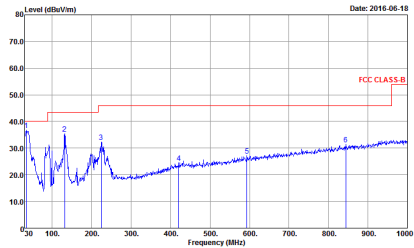
WIFI	5GHz 5725~5850MHz	
ANT	802.11a LF	
1	Horizontal	Vertical
QP / Peak	 <p>Site : 03GH11-HY Condition : FCC CLASS-B 3m BI-LO6 6111D-LF_ETC HORIZONTAL Detector : Peak Project : 651612 Mode : 35</p>	 <p>Site : 03GH11-HY Condition : FCC CLASS-B 3m BI-LO6 6111D-LF_ETC VERTICAL Detector : Peak Project : 651612 Mode : 35</p>

Appendix D. Duty Cycle Plots

Antenna	Band	Duty Cycle(%)	T(us)	1/T(kHz)	VBW Setting
1	802.11a	86.984	1370	0.729927007	1kHz
1	5GHz 802.11n HT20	86.486	1280	0.78125	1kHz
1	5GHz 802.11n HT40	75.598	632	1.582278481	3kHz

802.11a

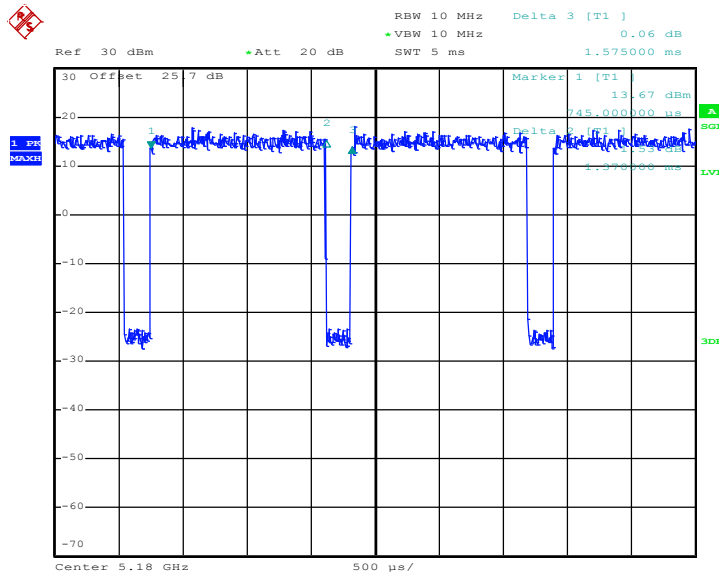

Date: 22.MAY.2016 09:02:32



802.11n HT20

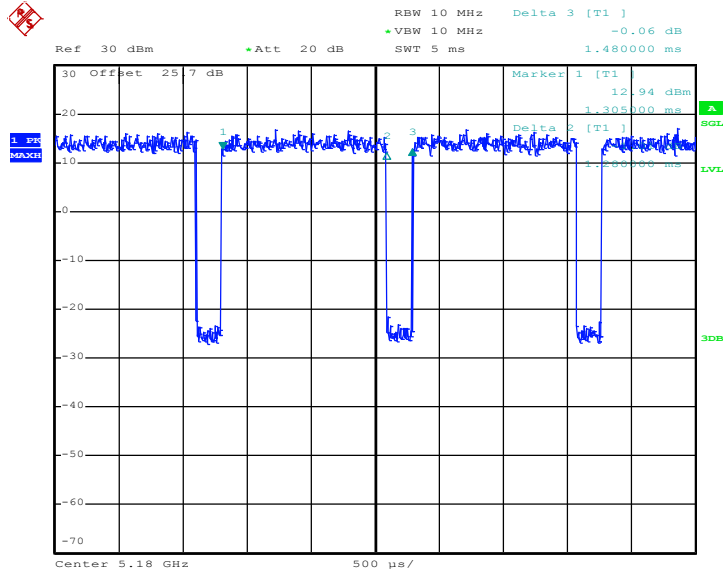

Date: 22.MAY.2016 09:08:23

802.11n HT40

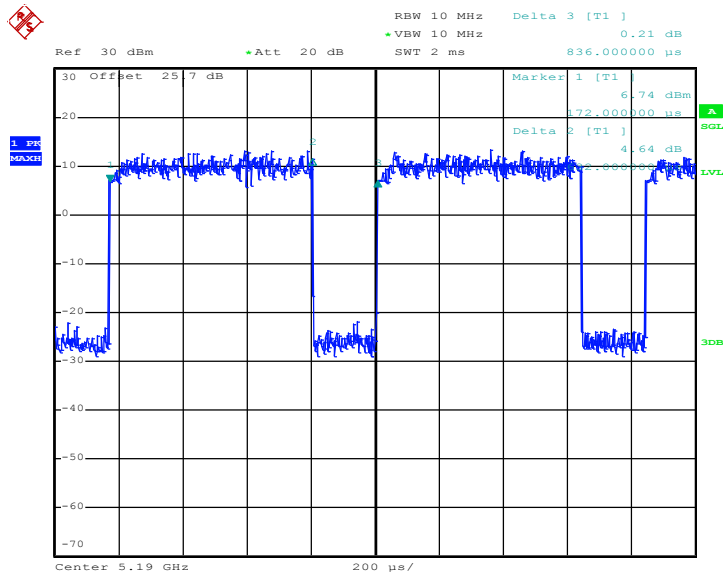

Date: 22.MAY.2016 09:23:04