



# FCC RF Test Report

**APPLICANT** : Motorola Mobility, LLC  
**EQUIPMENT** : Mobile Cellular Phone  
**BRAND NAME** : Motorola  
**MODEL NAME** : 5892  
**FCC ID** : IHDT56VC1  
**STANDARD** : FCC Part 15 Subpart E §15.407  
**CLASSIFICATION** : (NII) Unlicensed National Information Infrastructure

The product was received on Jul. 25, 2016 and testing was completed on Jul. 29, 2016. We, SPORTON INTERNATIONAL INC., would like to declare that the tested sample has been evaluated in accordance with the test procedures and has been in compliance with the applicable technical standards.

The test results in this report apply exclusively to the tested model / sample. Without written approval of SPORTON INTERNATIONAL INC., the test report shall not be reproduced except in full.

Reviewed by: Joseph Lin / Supervisor

Approved by: Jones Tsai / Manager



## SPORTON INTERNATIONAL INC.

No. 52, Hwa Ya 1<sup>st</sup> Rd., Hwa Ya Technology Park, Kwei-Shan District, Tao Yuan City, Taiwan, R.O.C.

SPORTON INTERNATIONAL INC.

TEL : 886-3-327-3456

FAX : 886-3-328-4978

FCC ID : IHDT56VC1

Page Number : 1 of 24

Report Issued Date : Aug. 04, 2016

Report Version : Rev. 01

Report Template No.: BU5-FR15EWL Version 1.4



# TABLE OF CONTENTS

**REVISION HISTORY..... 3**

**SUMMARY OF TEST RESULT ..... 4**

**1 GENERAL DESCRIPTION ..... 5**

    1.1 Applicant ..... 5

    1.2 Manufacturer..... 5

    1.3 Product Feature of Equipment Under Test..... 5

    1.4 Product Specification of Equipment Under Test..... 6

    1.5 Modification of EUT ..... 6

    1.6 Testing Location ..... 7

    1.7 Applicable Standards..... 8

**2 TEST CONFIGURATION OF EQUIPMENT UNDER TEST ..... 9**

    2.1 Carrier Frequency and Channel ..... 9

    2.2 Test Mode..... 10

    2.3 Connection Diagram of Test System..... 11

    2.4 Support Unit used in test configuration and system ..... 13

    2.5 EUT Operation Test Setup ..... 13

**3 TEST RESULT..... 14**

    3.1 Unwanted Emissions Measurement..... 14

    3.2 AC Conducted Emission Measurement..... 19

**4 LIST OF MEASURING EQUIPMENT ..... 23**

**5 UNCERTAINTY OF EVALUATION..... 24**

**APPENDIX A. RADIATED SPURIOUS EMISSION**

**APPENDIX B. RADIATED SPURIOUS EMISSION PLOTS**

**APPENDIX C. DUTY CYCLE PLOTS**

**APPENDIX D. ORIGINAL REPORT**





### SUMMARY OF TEST RESULT

Report Section	FCC Rule	Description	Limit	Result	Remark
3.1	15.407(b)	Unwanted Emissions	$\leq -17, -27$ dBm (depend on band) &15.209(a)	Pass	Under limit 1.03 dB at 5470.000 MHz
3.2	15.207	AC Conducted Emission	15.207(a)	Pass	Under limit 1.40 dB at 0.270 MHz



# 1 General Description

## 1.1 Applicant

**Motorola Mobility, LLC**

222 W Merchandise Mart Plaza, Suite 1800, Chicago, IL 60654, United States

## 1.2 Manufacturer

**Motorola Mobility, LLC**

222 W Merchandise Mart Plaza, Suite 1800, Chicago, IL 60654, United States

## 1.3 Product Feature of Equipment Under Test

Product Feature	
<b>Equipment</b>	Mobile Cellular Phone
<b>Brand Name</b>	Motorola
<b>Model Name</b>	5892
<b>FCC ID</b>	IHDT56VC1
<b>IMEI Code</b>	354130070011751 (for Radiation) 354130070011991 (for Conduction)
<b>EUT supports Radios application</b>	CDMA/EV-DO/GSM/EGPRS/WCDMA/HSPA/LTE/NFC WLAN 11b/g/n HT20 WLAN 11a/n HT20/HT40 Bluetooth v3.0 EDR Bluetooth v4.0 LE
<b>HW Version</b>	DVT2
<b>EUT Stage</b>	Identical Prototype

**Remark:** The above EUT's information was declared by manufacturer. Please refer to the specifications or user's manual for more detailed description.

Accessory List	
<b>WPC Cover</b>	Brand Name : INCIPIO
	Model Name : MT-043-CASE



### 1.4 Product Specification of Equipment Under Test

Standards-related Product Specification			
Tx/Rx Channel Frequency Range	5180 MHz ~ 5240 MHz		
	5260 MHz ~ 5320 MHz		
	5500 MHz ~ 5580 MHz		
	5660 MHz ~ 5700 MHz		
Type of Modulation	802.11a/n : OFDM (BPSK / QPSK / 16QAM / 64QAM)		
Antenna Type	ILA Antenna (The antenna peak gain of EUT is less than 6 dBi)		
Antenna Function Description		Ant.1	Ant.2
	802.11 a/n MIMO	V	V

### 1.5 Modification of EUT

No modifications are made to the EUT during all test items.



### 1.6 Testing Location

Sporton Lab is accredited to ISO 17025 by Taiwan Accreditation Foundation (TAF code : 1190) and the FCC designation No. TW1022 under the FCC 2.948(e) by Mutual Recognition Agreement (MRA) in FCC Test.

<b>Test Site</b>	SPORTON INTERNATIONAL INC.
<b>Test Site Location</b>	No. 52, Hwa Ya 1 <sup>st</sup> Rd., Hwa Ya Technology Park, Kwei-Shan District, Tao Yuan City, Taiwan, R.O.C. TEL: +886-3-327-3456 FAX: +886-3-328-4978
<b>Test Site No.</b>	<b>Sporton Site No.</b>
	CO05-HY

**Note:** The test site complies with ANSI C63.4 2014 requirement.

<b>Test Site</b>	SPORTON INTERNATIONAL INC.
<b>Test Site Location</b>	No.58, Aly. 75, Ln. 564, Wenhua 3rd Rd. Guishan Dist, Taoyuan City, Taiwan (R.O.C.) TEL: +886-3-327-0868 FAX: +886-3-327-0855
<b>Test Site No.</b>	<b>Sporton Site No.</b>
	03CH11-HY

**Note:** The test site complies with ANSI C63.4 2014 requirement.



## 1.7 Applicable Standards

According to the specifications of the manufacturer, the EUT must comply with the requirements of the following standards:

- ♦ FCC Part 15 Subpart E
- ♦ FCC KDB 789033 D02 General UNII Test Procedures New Rules v01r02
- ♦ FCC KDB 662911 D01 Multiple Transmitter Output v02r01.
- ♦ KDB 648474 D03 Handset Wireless Chargers Battery Covers v01r04
- ♦ ANSI C63.10-2013

**Remark:**

1. All test items were verified and recorded according to the standards and without any deviation during the test.
2. This EUT has also been tested and complied with the requirements of FCC Part 15, Subpart B, recorded in a separate test report.



## 2 Test Configuration of Equipment Under Test

The EUT has been associated with peripherals and configuration operated in a manner tended to maximize its emission characteristics in a typical application. Frequency range investigated: conducted emission (150 kHz to 30 MHz) and radiated emission (9 kHz to the 10th harmonic of the highest fundamental frequency or to 40 GHz, whichever is lower).

### 2.1 Carrier Frequency and Channel

Frequency Band	Channel	Freq. (MHz)	Channel	Freq. (MHz)
5150-5250 MHz Band 1 (U-NII-1)	36	5180	44	5220
	<b>38</b>	<b>5190</b>	<b>46</b>	<b>5230</b>
	40	5200	48	5240

Frequency Band	Channel	Freq. (MHz)	Channel	Freq. (MHz)
5250-5350 MHz Band 2 (U-NII-2A)	52	5260	60	5300
	<b>54</b>	<b>5270</b>	<b>62</b>	<b>5310</b>
	56	5280	64	5320

Frequency Band	Channel	Freq. (MHz)	Channel	Freq. (MHz)
5470-5600 MHz and 5650-5725 MHz Band 3 (U-NII-2C)	100	5500	116	5580
	<b>102</b>	<b>5510</b>	132	5660
	104	5520	<b>134</b>	<b>5670</b>
	108	5540	136	5680
	<b>110</b>	<b>5550</b>	140	5700
	112	5560		

**Note:** The above Frequency and Channel in boldface were 802.11n HT40.



## 2.2 Test Mode

Final test mode of conducted test items and radiated spurious emissions are considering the modulation and worse data rates as below table.

Modulation	Data Rate
802.11a	6 Mbps

Test Cases	
AC Conducted Emission	Mode 1 : GSM1900 Idle + Bluetooth Link + WLAN (5GHz) Link + Camera + WPC Back Cover + WPC Charging Pad + USB Cable (Charging from Adapter)
	Mode 2 : WCDMA Band V Idle + Bluetooth Link + WLAN (5GHz) Link + MPEG4 + WPC Back Cover + PMA Charging Pad + Adapter

Ch. #	Band III : 5470-5600 MHz and 5650-5725MHz	
	802.11a	
L	Low	100
M	Middle	-
H	High	-

## 2.3 Connection Diagram of Test System

<WLAN Tx with WPC Charging Mode>

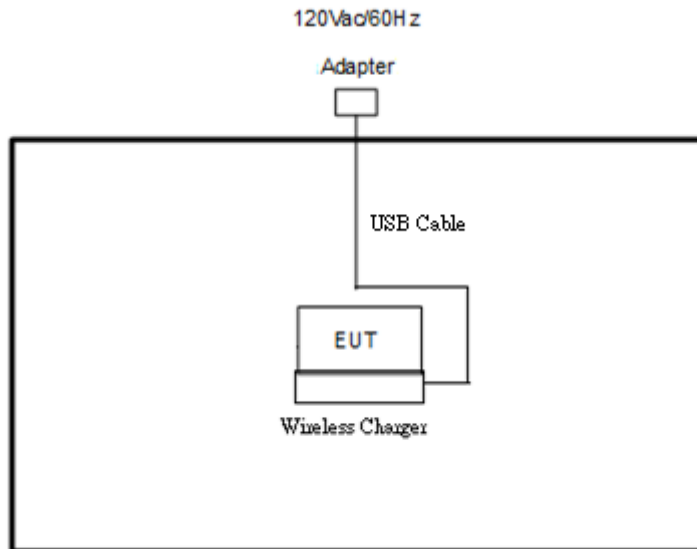

<AC Conducted Emission with WPC Charging Mode>

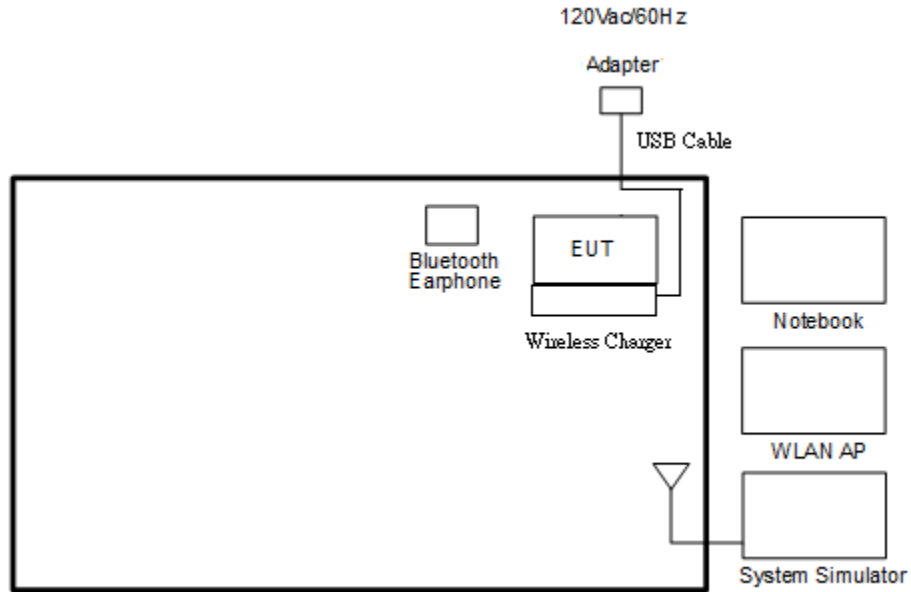

<AC Conducted Emission with PMA Charging Mode>

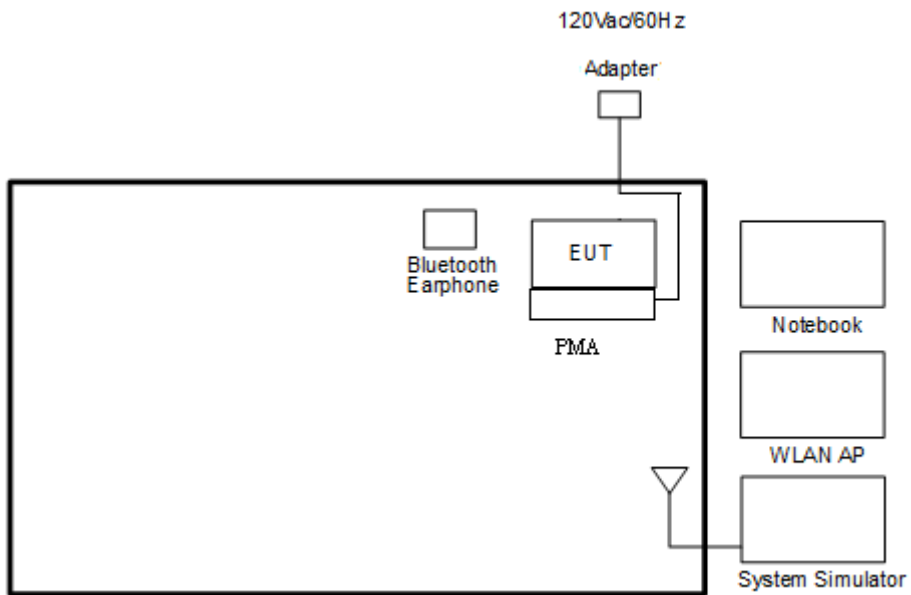



## 2.4 Support Unit used in test configuration and system

Item	Equipment	Trade Name	Model Name	FCC ID	Data Cable	Power Cord
1.	System Simulator	Anritsu	MT8820C	N/A	N/A	Unshielded, 1.8 m
2.	WLAN AP	D-Link	DIR-628	KA2DIR628A2	N/A	Unshielded, 1.8 m
3.	Bluetooth Earphone	Sony Ericsson	MW600	PY7DDA-2029	N/A	N/A
4.	Notebook	DELL	Latitude E6320	FCC DoC/ Contains FCC ID: QDS-BRCM1054	N/A	AC I/P: Unshielded, 1.2 m DC O/P: Shielded, 1.8 m
5.	SD Card	SanDisk	MicroSD HC	FCC DoC	N/A	N/A
6.	Wireless Charger	LG	WCD-100	FCC DoC	N/A	N/A
7.	PMA	DURACELL	M-018B-518A	FCC DoC	N/A	N/A
8.	USB Cable	Motorola	SKN6461A	N/A	Unshielded, 1.0 m	N/A
9.	Adapter	Motorola	SPN5865A	N/A	N/A	N/A

## 2.5 EUT Operation Test Setup

For WLAN function, programmed RF utility, "QRCT" installed in the notebook make the EUT provide functions like channel selection and power level for continuous transmitting and receiving signals.



### 3 Test Result

#### 3.1 Unwanted Emissions Measurement

This section as specified in FCC Part 15.407(b) is to measure unwanted emissions through radiated measurement for band edge spurious emissions and out of band emissions measurement. The unwanted emissions shall comply with 15.407(b)(1) to (6), and restricted bands per FCC Part15.205.

##### 3.1.1 Limit of Unwanted Emissions

(1) For transmitters operating in the 5150-5250 MHz band: all emissions outside of the 5150-5350 MHz band shall not exceed an EIRP of -27dBm/MHz.

For transmitters operating in the 5250-5350 MHz band: all emissions outside of the 5150-5350 MHz band shall not exceed an EIRP of -27 dBm/MHz. Devices operating in the 5250-5350 MHz band that generate emissions in the 5150-5250 MHz band must meet all applicable technical requirements for operation in the 5150-5250 MHz band (including indoor use) or alternatively meet an out-of-band emission EIRP limit of -27 dBm/MHz in the 5150-5250 MHz band.

For transmitters operating in the 5470-5600 MHz and 5650-5725MHz band: all emissions outside of the 5470-5600 MHz and 5650-5725MHz band shall not exceed an EIRP of -27 dBm/MHz.

(2) Unwanted spurious emissions fallen in restricted bands per FCC Part15.205 shall comply with the general field strength limits set forth in § 15.209 as below table,

Frequency (MHz)	Field Strength (microvolts/meter)	Measurement Distance (meters)
0.009 – 0.490	2400/F(kHz)	300
0.490 – 1.705	24000/F(kHz)	30
1.705 – 30.0	30	30
30 – 88	100	3
88 – 216	150	3
216 - 960	200	3
Above 960	500	3

**Note:** The following formula is used to convert the EIRP to field strength.

$$E = \frac{1000000\sqrt{30P}}{3} \mu\text{V/m, where P is the eirp (Watts)}$$

EIRP (dBm)	Field Strength at 3m (dBµV/m)
-17	78.3
- 27	68.3



- (3) KDB789033 D01 v01r02 G)2)c) As specified in 15.407(b), emissions above 1000 MHz that are outside of the restricted bands are subject to a peak emission limit of -27 dBm/MHz (or -17 dBm/MHz as specified in 15.407(b)(4)). However, an out-of-band emission that complies with both the average and peak limits of 15.209 is not required to satisfy the -27 dBm/MHz or -17 dBm/MHz peak emission limit.

### 3.1.2 Measuring Instruments

The measuring equipment is listed in the section 4 of this test report.

### 3.1.3 Test Procedures

1. The testing follows FCC KDB 789033 D02 General UNII Test Procedures New Rules v01r02. Section G) Unwanted emissions measurement.
  - (1) Procedure for Unwanted Emissions Measurements Below 1000MHz
    - RBW = 120 kHz
    - VBW = 300 kHz
    - Detector = Peak
    - Trace mode = max hold
  - (2) Procedure for Peak Unwanted Emissions Measurements Above 1000 MHz
    - RBW = 1 MHz
    - VBW  $\geq$  3 MHz
    - Detector = Peak
    - Sweep time = auto
    - Trace mode = max hold
  - (3) Procedures for Average Unwanted Emissions Measurements Above 1000MHz
    - RBW = 1 MHz
    - VBW = 10 Hz, when duty cycle is no less than 98 percent.
    - VBW  $\geq$  1/T, when duty cycle is less than 98 percent where T is the minimum transmission duration over which the transmitter is on and is transmitting at its maximum power control level for the tested mode of operation.

2. The EUT was placed on a turntable with 0.8 meter for frequency below 1GHz and 1.5 meter for frequency above 1GHz respectively above ground.
3. The EUT was set 3 meters from the interference receiving antenna which was mounted on the top of a variable height antenna tower.
4. The antenna is a broadband antenna and its height is adjusted between one meter and four meters above ground to find the maximum value of the field strength for both horizontal polarization and vertical polarization of the antenna.
5. For each suspected emission, the EUT was arranged to its worst case and then adjust the antenna tower (from 1 m to 4 m) and turntable (from 0 degree to 360 degrees) to find the maximum reading.
6. For testing below 1GHz, if the emission level of the EUT in peak mode was 3 dB lower than the limit specified, then peak values of EUT will be reported, otherwise, the emissions will be repeated one by one using the CISPR quasi-peak method and reported.
7. For testing above 1GHz, the emission level of the EUT in peak mode was 20dB lower than average limit (that means the emission level in average mode also complies with the limit in average mode), then peak values of EUT will be reported, otherwise, the emissions will be measured in average mode again and reported.

### 3.1.4 Test Setup

For radiated emissions below 30MHz

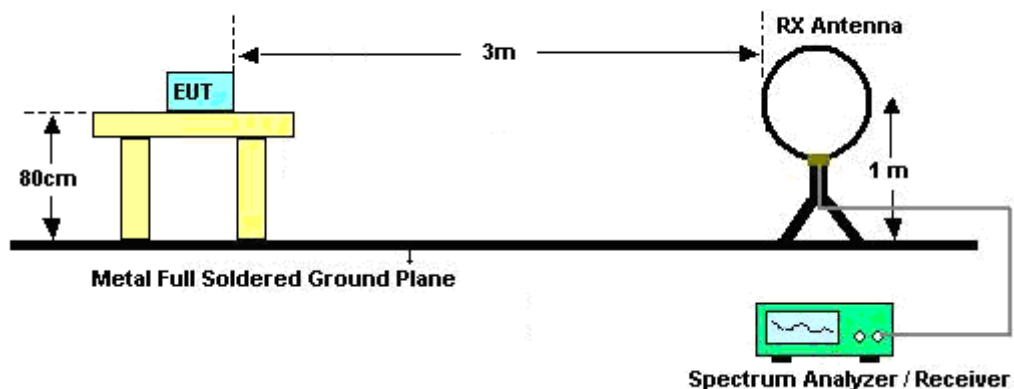

For radiated emissions from 30MHz to 1GHz

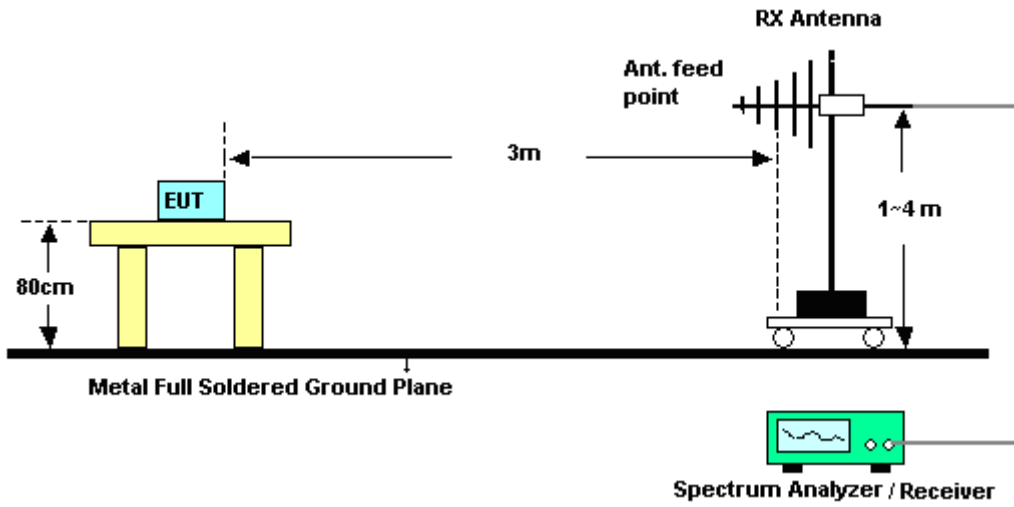

For radiated emissions above 1GHz

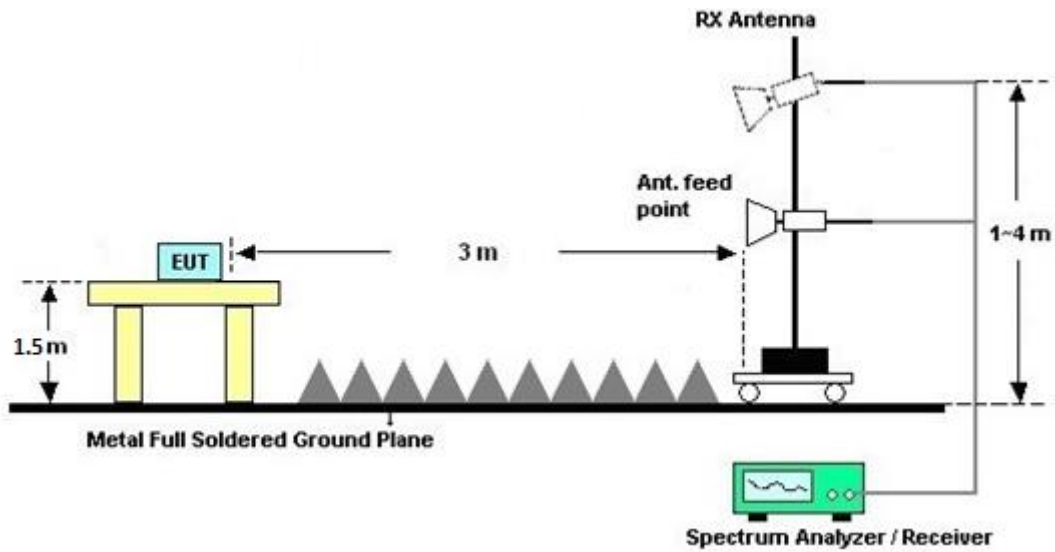



### **3.1.5 Test Results of Radiated Emissions (9 kHz ~ 30 MHz)**

The low frequency, which started from 9 kHz to 30MHz, was pre-scanned and the result which was 20dB lower than the limit line per 15.31(o) was not reported.

### **3.1.6 Test Result of Radiated Band Edges**

Please refer to Appendix A and B

### **3.1.7 Duty Cycle**

Please refer to Appendix C.

### **3.1.8 Test Result of Unwanted Radiated Emission (30MHz ~ 10th Harmonic)**

Please refer to Appendix A and B



### 3.2 AC Conducted Emission Measurement

#### 3.2.1 Limit of AC Conducted Emission

For equipment that is designed to be connected to the public utility (AC) power line, the radio frequency voltage that is conducted back onto the AC power line on any frequency or frequencies within the band 150 kHz to 30 MHz shall not exceed the limits in the following table.

Frequency of emission (MHz)	Conducted limit (dB $\mu$ V)	
	Quasi-peak	Average
0.15-0.5	66 to 56*	56 to 46*
0.5-5	56	46
5-30	60	50

\*Decreases with the logarithm of the frequency.

#### 3.2.2 Measuring Instruments

The measuring equipment is listed in the section 4 of this test report.

#### 3.2.3 Test Procedures

1. The EUT was placed 0.4 meter from the conducting wall of the shielding room was kept at least 80 centimeters from any other grounded conducting surface.
2. Connect EUT to the power mains through a line impedance stabilization network (LISN).
3. All the support units are connecting to the other LISN.
4. The LISN provides 50 ohm coupling impedance for the measuring instrument.
5. The FCC states that a 50 ohm, 50 microhenry LISN should be used.
6. Both sides of AC line were checked for maximum conducted interference.
7. The frequency range from 150 kHz to 30 MHz was searched.
8. Set the test-receiver system to Peak Detect Function and specified bandwidth with Maximum Hold Mode.

### 3.2.4 Test Setup

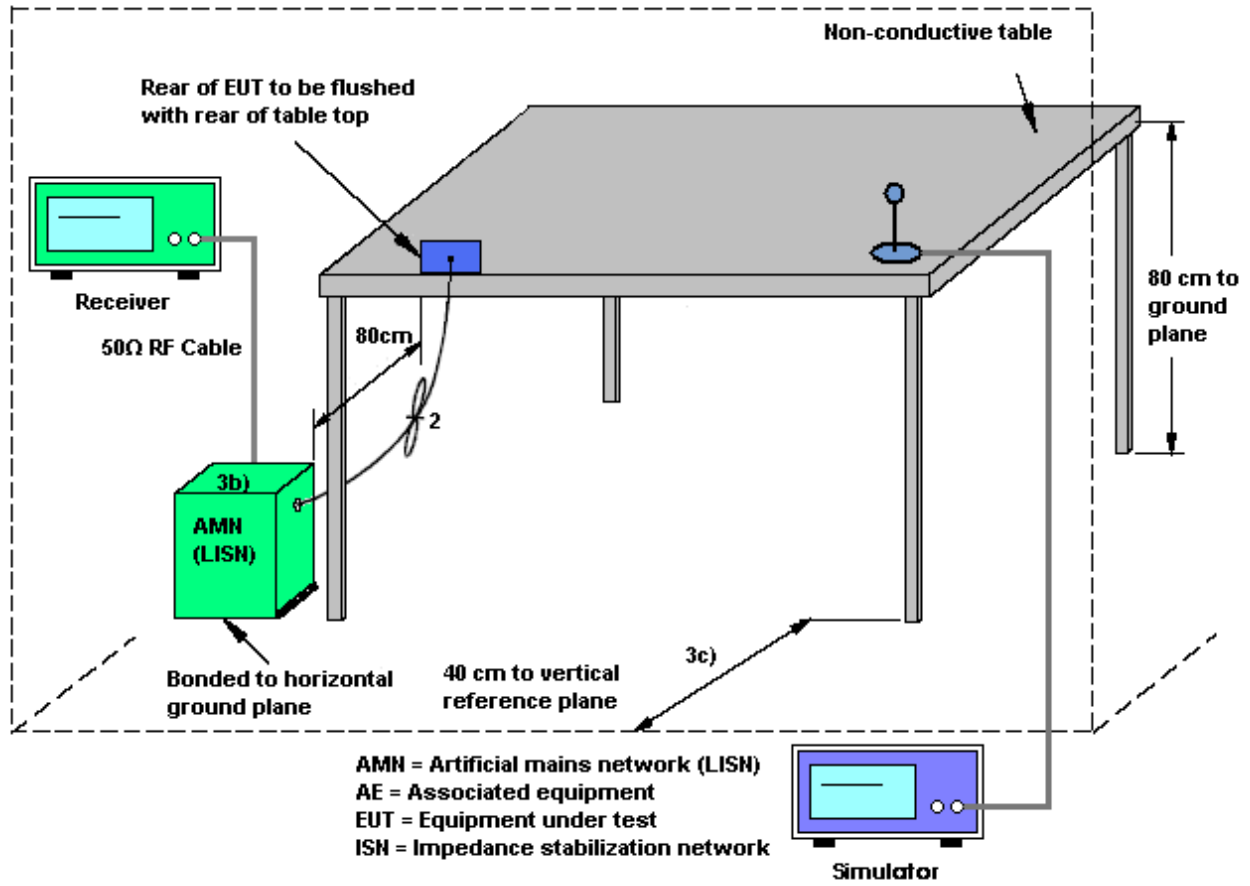



### 3.2.5 Test Result of AC Conducted Emission

Test Mode :	Mode 2	Temperature :	22~23°C
Test Engineer :	Arthur Hsieh and Kai-Chun Chu	Relative Humidity :	51~52%
Test Voltage :	120Vac / 60Hz	Phase :	Line
Function Type :	WCDMA Band V Idle + Bluetooth Link + WLAN (5GHz) Link + MPEG4 + WPC Back Cover + PMA Charging Pad + Adapter		

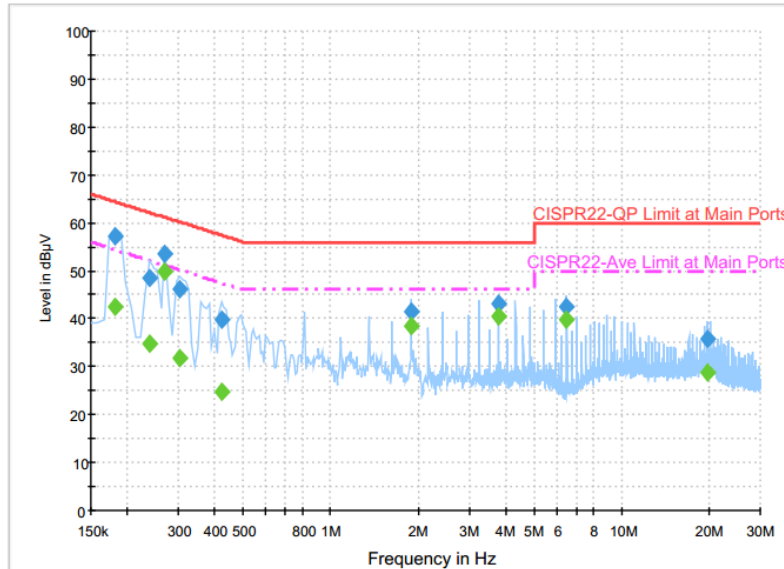

**Final Result : QuasiPeak**

Frequency (MHz)	QuasiPeak (dBµV)	Filter	Line	Corr. (dB)	Margin (dB)	Limit (dBµV)
0.182000	57.1	Off	L1	19.6	7.3	64.4
0.238000	48.4	Off	L1	19.6	13.8	62.2
0.270000	53.4	Off	L1	19.6	7.7	61.1
0.302000	46.0	Off	L1	19.6	14.2	60.2
0.422000	39.8	Off	L1	19.6	17.6	57.4
1.894000	41.6	Off	L1	19.7	14.4	56.0
3.790000	43.2	Off	L1	19.8	12.8	56.0
6.494000	42.6	Off	L1	20.0	17.4	60.0
19.750000	35.7	Off	L1	20.7	24.3	60.0

**Final Result : Average**

Frequency (MHz)	Average (dBµV)	Filter	Line	Corr. (dB)	Margin (dB)	Limit (dBµV)
0.182000	42.4	Off	L1	19.6	12.0	54.4
0.238000	34.9	Off	L1	19.6	17.3	52.2
0.270000	49.7	Off	L1	19.6	1.4	51.1
0.302000	31.8	Off	L1	19.6	18.4	50.2
0.422000	24.6	Off	L1	19.6	22.8	47.4
1.894000	38.6	Off	L1	19.7	7.4	46.0
3.790000	40.5	Off	L1	19.8	5.5	46.0
6.494000	39.9	Off	L1	20.0	10.1	50.0
19.750000	28.9	Off	L1	20.7	21.1	50.0



Test Mode :	Mode 2	Temperature :	22~23°C
Test Engineer :	Arthur Hsieh and Kai-Chun Chu	Relative Humidity :	51~52%
Test Voltage :	120Vac / 60Hz	Phase :	Neutral
Function Type :	WCDMA Band V Idle + Bluetooth Link + WLAN (5GHz) Link + MPEG4 + WPC Back Cover + PMA Charging Pad + Adapter		

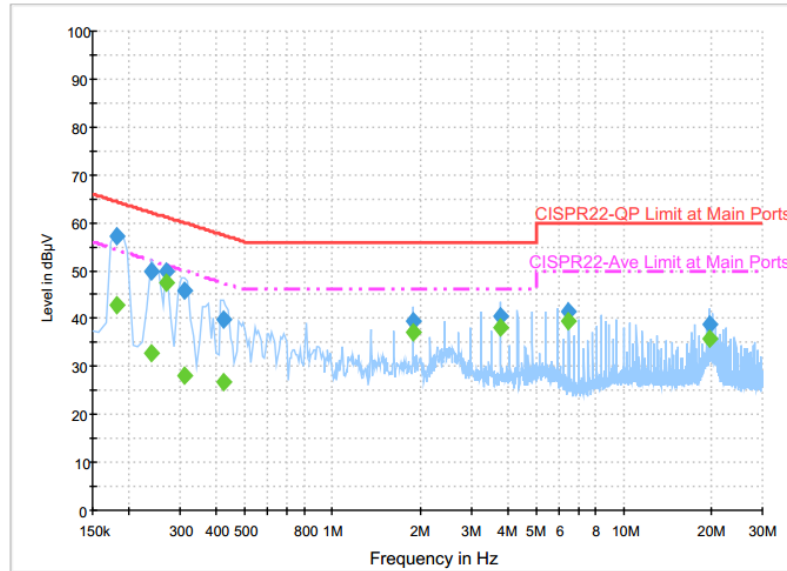

**Final Result : QuasiPeak**

Frequency (MHz)	QuasiPeak (dBµV)	Filter	Line	Corr. (dB)	Margin (dB)	Limit (dBµV)
0.182000	57.1	Off	N	19.6	7.3	64.4
0.238000	49.9	Off	N	19.6	12.3	62.2
0.270000	49.9	Off	N	19.6	11.2	61.1
0.310000	45.7	Off	N	19.6	14.3	60.0
0.422000	39.9	Off	N	19.6	17.5	57.4
1.894000	39.4	Off	N	19.7	16.6	56.0
3.790000	40.6	Off	N	19.7	15.4	56.0
6.494000	41.6	Off	N	19.9	18.4	60.0
19.758000	38.7	Off	N	20.8	21.3	60.0

**Final Result : Average**

Frequency (MHz)	Average (dBµV)	Filter	Line	Corr. (dB)	Margin (dB)	Limit (dBµV)
0.182000	42.8	Off	N	19.6	11.6	54.4
0.238000	32.7	Off	N	19.6	19.5	52.2
0.270000	47.5	Off	N	19.6	3.6	51.1
0.310000	28.0	Off	N	19.6	22.0	50.0
0.422000	26.9	Off	N	19.6	20.5	47.4
1.894000	37.1	Off	N	19.7	8.9	46.0
3.790000	38.2	Off	N	19.7	7.8	46.0
6.494000	39.4	Off	N	19.9	10.6	50.0
19.758000	35.7	Off	N	20.8	14.3	50.0



## 4 List of Measuring Equipment

Instrument	Manufacturer	Model No.	Serial No.	Characteristics	Calibration Date	Test Date	Due Date	Remark
AC Power Source	ChainTek	APC-1000W	N/A	N/A	N/A	Jul. 29, 2016	N/A	Conduction (CO05-HY)
EMI Test Receiver	Rohde & Schwarz	ESCI 7	100724	9kHz~7GHz	Aug. 26, 2015	Jul. 29, 2016	Aug. 25, 2016	Conduction (CO05-HY)
LISN	Rohde & Schwarz	ENV216	100080	9kHz~30MHz	Dec. 02, 2015	Jul. 29, 2016	Dec. 01, 2016	Conduction (CO05-HY)
Loop Antenna	Rohde & Schwarz	HFH2-Z2	100315	9 kHz~30 MHz	Sep. 02, 2015	Jul. 28, 2016 ~ Jul. 29, 2016	Sep. 01, 2016	Radiation (03CH11-HY)
Amplifier	SONOMA	310N	187312	9kHz~1GHz	Nov. 20, 2015	Jul. 28, 2016 ~ Jul. 29, 2016	Nov. 19, 2016	Radiation (03CH11-HY)
Bilog Antenna	TESEQ	CBL 6111D	35414	30MHz~1GHz	Nov. 17, 2015	Jul. 28, 2016 ~ Jul. 29, 2016	Nov. 16, 2016	Radiation (03CH11-HY)
Horn Antenna	SCHWARZBECK	BBHA 9120 D	9120D-1326	1GHz ~ 18GHz	Oct. 08, 2015	Jul. 28, 2016 ~ Jul. 29, 2016	Oct. 07, 2016	Radiation (03CH11-HY)
Preamplifier	Keysight	83017A	MY53270080	1GHz~26.5GHz	Nov. 19, 2015	Jul. 28, 2016 ~ Jul. 29, 2016	Nov. 18, 2016	Radiation (03CH11-HY)
Preamplifier	MITEQ	AMF-7D-0010 1800-30-10P	1902247	1GHz~18GHz	Jun. 22, 2016	Jul. 28, 2016 ~ Jul. 29, 2016	Jun. 21, 2017	Radiation (03CH11-HY)
Spectrum Analyzer	Keysight	N9010A	MY54200486	10Hz ~ 44GHZ	Sep. 24, 2015	Jul. 28, 2016 ~ Jul. 29, 2016	Sep. 23, 2016	Radiation (03CH11-HY)
Antenna Mast	EMEC	AM-BS-4500-B	N/A	1~4m	N/A	Jul. 28, 2016 ~ Jul. 29, 2016	N/A	Radiation (03CH11-HY)
Turn Table	EMEC	TT 2000	N/A	0~360 Degree	N/A	Jul. 28, 2016 ~ Jul. 29, 2016	N/A	Radiation (03CH11-HY)
SHF-EHF Horn Antenna	SCHWARZBECK	BBHA 9170	BBHA917058 4	18GHz- 40GHz	Nov. 02, 2015	Jul. 28, 2016 ~ Jul. 29, 2016	Nov. 01, 2016	Radiation (03CH11-HY)
Preamplifier	MITEQ	TTA0204	1872107	2GHz~40GHz	Feb. 15, 2016	Jul. 28, 2016 ~ Jul. 29, 2016	Feb. 14, 2017	Radiation (03CH11-HY)



## 5 Uncertainty of Evaluation

### Uncertainty of Conducted Emission Measurement (150kHz ~ 30MHz)

Measuring Uncertainty for a Level of Confidence of 95% ( $U = 2Uc(y)$ )	2.26
---	------

### Uncertainty of Radiated Emission Measurement (30 MHz ~ 1000 MHz)

Measuring Uncertainty for a Level of Confidence of 95% ( $U = 2Uc(y)$ )	3.37
---	------



## Appendix A. Radiated Spurious Emission

Test Engineer :	J.C. Liang, Jacky Hung and Ken Wu	Temperature :	20~23°C
		Relative Humidity :	50~54%

**Band 3 - 5470~5725MHz**  
**WIFI 802.11a (Band Edge @ 3m)**

**<WPC Charging Mode>**

WIFI Ant.	Note	Frequency	Level	Over Limit	Limit Line	Read Level	Antenna Factor	Cable Loss	Preamp Factor	Ant Pos	Table Pos	Peak Avg.	Pol.
1+2		( MHz )	( dBμV/m )	( dB )	( dBμV/m )	( dBμV )	( dB/m )	( dB )	( dB )	( cm )	( deg )	( P/A )	( H/V )
802.11a CH 100 5500MHz		5468.32	64.71	-9.29	74	55.42	31.96	10.81	33.48	297	108	P	H
		5470	52.97	-1.03	54	43.68	31.96	10.81	33.48	297	108	A	H
	*	5500	104.42	-	-	95.09	32	10.81	33.48	297	108	P	H
	*	5500	96.24	-	-	86.91	32	10.81	33.48	297	108	A	H
		5753.8	47.73	-26.27	74	38.31	32.36	10.63	33.57	297	108	P	H
		5758.175	39.39	-14.61	54	29.98	32.36	10.63	33.58	297	108	A	H
		5466.88	58.32	-15.68	74	49.03	31.96	10.81	33.48	249	206	P	V
		5469.76	48.65	-5.35	54	39.36	31.96	10.81	33.48	249	206	A	V
	*	5500	99.64	-	-	90.31	32	10.81	33.48	249	206	P	V
	*	5500	91.74	-	-	82.41	32	10.81	33.48	249	206	A	V
		5729.825	47.89	-26.11	74	38.5	32.31	10.65	33.57	249	206	P	V
		5761.325	39.25	-14.75	54	29.84	32.36	10.63	33.58	249	206	A	V
Remark	1. No other spurious found. 2. All results are PASS against Peak and Average limit line.												



Band 3 - 5470~5725MHz
WIFI 802.11a (Harmonic @ 3m)

Table with 14 columns: WIFI Ant. 1+2, Note, Frequency (MHz), Level (dBµV/m), Over Limit (dB), Limit Line (dBµV/m), Read Level (dBµV), Antenna Factor (dB/m), Cable Loss (dB), Preamp Factor (dB), Ant Pos (cm), Table Pos (deg), Peak Avg. (P/A), Pol. (H/V). Rows include data for 802.11a CH 100 5500MHz and a Remark section.



**Band 3 - 5470~5725MHz  
Emission below 1GHz  
WIFI 802.11a (LF @ 3m)**

WIFI Ant. 1+2	Note	Frequency ( MHz )	Level ( dBμV/m )	Over Limit ( dB )	Limit Line ( dBμV/m )	Read Level ( dBμV )	Antenna Factor ( dB/m )	Cable Loss ( dB )	Preamp Factor ( dB )	Ant Pos ( cm )	Table Pos ( deg )	Peak Avg. ( P/A )	Pol. ( H/V )	
802.11a LF		69.15	32.16	-7.84	40	50.43	12.35	1.17	31.79	-	-	P	H	
		97.77	37.79	-5.71	43.5	52.54	15.86	1.17	31.78	258	312	P	H	
		208.2	36.97	-6.53	43.5	50.85	16.16	1.74	31.78	-	-	P	H	
		311.9	29.78	-16.22	46	39.26	20.05	2.23	31.76	-	-	P	H	
		856.5	31.67	-14.33	46	30.61	28.94	3.77	31.65	-	-	P	H	
		969.9	33	-21	54	29.43	30.56	3.89	30.88	-	-	P	H	
														H
														H
														H
														H
														H
														H
			39.72	36.65	-3.35	40	47.24	20.3	0.93	31.82	265	314	P	V
			53.76	33.62	-6.38	40	50.49	14	0.93	31.8	-	-	P	V
			96.69	29.72	-13.78	43.5	44.59	15.74	1.17	31.78	-	-	P	V
			763.4	29.77	-16.23	46	30.25	27.86	3.62	31.96	-	-	P	V
			855.8	32.37	-13.63	46	31.32	28.93	3.77	31.65	-	-	P	V
			958	32.98	-13.02	46	29.48	30.58	3.89	30.97	-	-	P	V
														V
														V
													V	
													V	
													V	
													V	
Remark	1. No other spurious found. 2. All results are PASS against limit line.													



**Note symbol**

*	<b>Fundamental Frequency</b> which can be ignored. However, the level of any unwanted emissions shall not exceed the level of the fundamental frequency.
!	Test result is <b>over limit</b> line.
P/A	<b>Peak</b> or <b>Average</b>
H/V	<b>Horizontal</b> or <b>Vertical</b>



A calculation example for radiated spurious emission is shown as below:

WIFI	Note	Frequency	Level	Over	Limit	Read	Antenna	Cable	Preamp	Ant	Table	Peak	Pol.
Ant.				Limit	Line	Level	Factor	Loss	Factor	Pos	Pos	Avg.	
1+2		( MHz )	( dBμV/m )	( dB )	( dBμV/m )	( dBμV )	( dB/m )	( dB )	( dB )	( cm )	( deg )	( P/A )	( H/V )
802.11b		2390	55.45	-18.55	74	54.51	32.22	4.58	35.86	103	308	P	H
CH 01													
2412MHz		2390	43.54	-10.46	54	42.6	32.22	4.58	35.86	103	308	A	H

- Level(dBμV/m) =  
Antenna Factor(dB/m) + Cable Loss(dB) + Read Level(dBμV) - Preamp Factor(dB)
- Over Limit(dB) = Level(dBμV/m) – Limit Line(dBμV/m)

**For Peak Limit @ 2390MHz:**

- Level(dBμV/m)  
= Antenna Factor(dB/m) + Cable Loss(dB) + Read Level(dBμV) - Preamp Factor(dB)  
= 32.22(dB/m) + 4.58(dB) + 54.51(dBμV) – 35.86 (dB)  
= 55.45 (dBμV/m)
- Over Limit(dB)  
= Level(dBμV/m) – Limit Line(dBμV/m)  
= 55.45(dBμV/m) – 74(dBμV/m)  
= -18.55(dB)

**For Average Limit @ 2390MHz:**

- Level(dBμV/m)  
= Antenna Factor(dB/m) + Cable Loss(dB) + Read Level(dBμV) - Preamp Factor(dB)  
= 32.22(dB/m) + 4.58(dB) + 42.6(dBμV) – 35.86 (dB)  
= 43.54 (dBμV/m)
- Over Limit(dB)  
= Level(dBμV/m) – Limit Line(dBμV/m)  
= 43.54(dBμV/m) – 54(dBμV/m)  
= -10.46(dB)

Both peak and average measured complies with the limit line, so test result is “PASS”.



## Appendix B. Radiated Spurious Emission

Test Engineer :	J.C. Liang, Jacky Hung and Ken Wu	Temperature :	20~23°C
		Relative Humidity :	50~54%

### Note symbol

-L	Low channel location
-R	High channel location



**Band 3 - 5470~5725MHz**  
**WIFI 802.11a (Band Edge @ 3m)**

**<WPC Charging Mode>**

WIFI	Band 3 5470~5725MHz Band Edge @ 3m	
ANT	802.11a CH100 5500MHz	
1+2	Horizontal	Fundamental
<b>Peak</b>	<p>Site : 03CH11-HY            Condition : PEAK_BE_74 3m HORN 9120D-HF HORIZONTAL            Detector : Peak            Project : 651612-13            Mode : 1                  : WPC cover + LG</p>	<p>Site : 03CH11-HY            Condition : PEAK_74 3m HORN 9120D-HF HORIZONTAL            Detector : Peak            Project : 651612-13            Mode : 1                  : WPC cover + LG</p>
<b>Avg.</b>	<p>Site : 03CH11-HY            Condition : AV6_BE_54 3m HORN 9120D-HF HORIZONTAL            Detector : Peak            Project : 651612-13            Mode : 1                  : WPC cover + LG</p>	<b>Left blank</b>

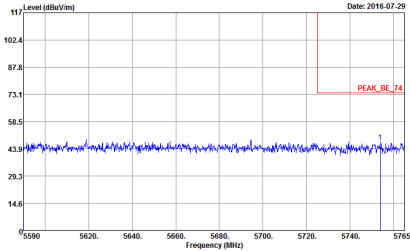
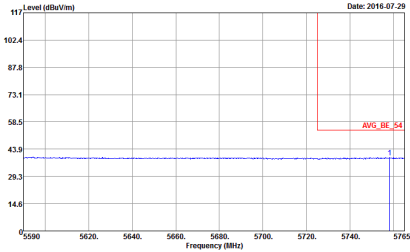

WIFI	Band 3 5470~5725MHz Band Edge @ 3m	
ANT	802.11a CH100 5500MHz	
1+2	Horizontal	Fundamental
Peak	 <p>Date: 2016-07-29</p> <p>Site : 03CH11-HY  Condition : PEAK_BE_74 3m HORN 9120D-HF HORIZONTAL  Detector : Peak  Project : 651612-13  Mode : WPC cover + L6</p>	
Avg.	 <p>Date: 2016-07-29</p> <p>Site : 03CH11-HY  Condition : AVG_BE_54 3m HORN 9120D-HF HORIZONTAL  Detector : Peak  Project : 651612-13  Mode : WPC cover + L6</p>	Left blank



WIFI	Band 3 5470~5725MHz Band Edge @ 3m	
ANT	802.11a CH100 5500MHz	
1+2	Vertical	Fundamental
<p><b>Peak</b></p>	<p>Date: 2016-07-29</p> <p>Site : 03CH11-HY            Condition : PEAK_BE_74 3m HORN 9120D-HF VERTICAL            Detector : Peak            Project : 651612-13            Mode : WPC cover + L6</p>	<p>Date: 2016-07-29</p> <p>Site : 03CH11-HY            Condition : PEAK_74 3m HORN 9120D-HF VERTICAL            Detector : Peak            Project : 651612-13            Mode : WPC cover + L6</p>
<p><b>Avg.</b></p>	<p>Date: 2016-07-29</p> <p>Site : 03CH11-HY            Condition : AVG_BE_54 3m HORN 9120D-HF VERTICAL            Detector : Peak            Project : 651612-13            Mode : WPC cover + L6</p>	<p><b>Left blank</b></p>

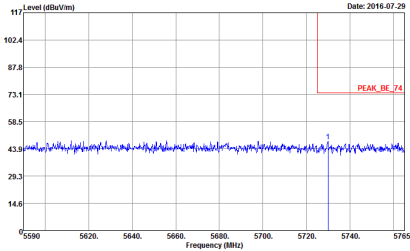
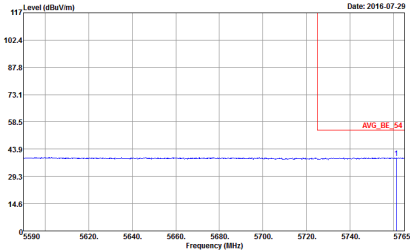

WIFI	Band 3 5470~5725MHz Band Edge @ 3m	
ANT	802.11a CH100 5500MHz	
1+2	Vertical	Fundamental
Peak	 <p>Site : 03CH11-HY  Condition : PEAK_BE_74 3m HORN 9120D-HF VERTICAL  Detector : Peak  Project : 651612-13  Mode : WPC cover + L6</p>	
Avg.	 <p>Site : 03CH11-HY  Condition : AVG_BE_54 3m HORN 9120D-HF VERTICAL  Detector : Peak  Project : 651612-13  Mode : WPC cover + L6</p>	Left blank



**Band 3 - 5470~5725MHz**

**WIFI 802.11a (Harmonic @ 3m)**

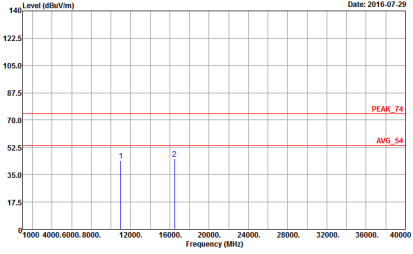
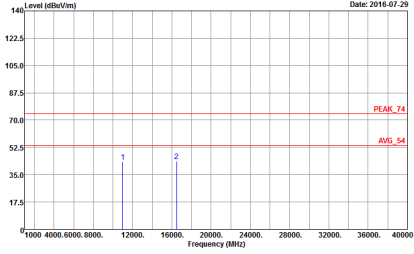
WIFI	Band 3 5470~5725MHz Harmonic @ 3m	
ANT	802.11a CH100 5500MHz	
1+2	Horizontal	Vertical
<p><b>Peak</b></p> <p><b>Avg.</b></p>	 <p>Site : 03CH11-HY            Condition : PEAK_74 3m 9170 SHF HORM_150809 HORIZONTAL            Detector : Peak            Project : 651612-13            Mode : 1            : WPC cover + LG</p>	 <p>Site : 03CH11-HY            Condition : PEAK_74 3m 9170 SHF HORM_150809 VERTICAL            Detector : Peak            Project : 651612-13            Mode : 1            : WPC cover + LG</p>



Emission below 1GHz  
5GHz WIFI 802.11a (LF)

WIFI	5GHz WIFI	
ANT	802.11a LF	
1+2	Horizontal	Vertical
QP / Peak	<p>Site : 03CH11-HY Condition : QP 3m BI-LOG 6111D-LF_ETC HORIZONTAL Detector : Peak Project : 651612-13 Mode : I : WPC cover + LG</p>	<p>Site : 03CH11-HY Condition : QP 3m BI-LOG 6111D-LF_ETC VERTICAL Detector : Peak Project : 651612-13 Mode : I : WPC cover + LG</p>

## Appendix C. Duty Cycle Plots

Antenna	Band	Duty Cycle(%)	T(us)	1/T(kHz)	VBW Setting
1+2	802.11a	86.984	1370	0.730	1kHz
1+2	5GHz 802.11n HT20	86.486	1280	0.781	1kHz
1+2	5GHz 802.11n HT40	75.598	632	1.582	3kHz

### 802.11a

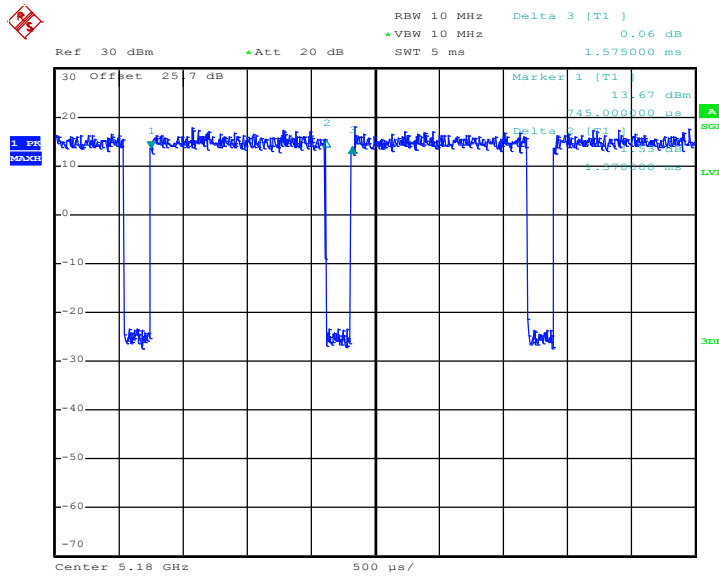

Date: 22.MAY.2016 09:02:32



### 802.11n HT20

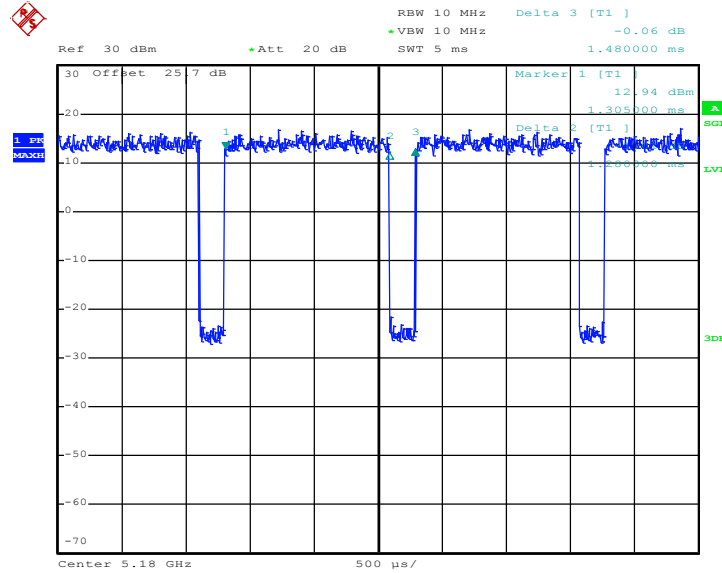

Date: 22.MAY.2016 09:08:23

### 802.11n HT40

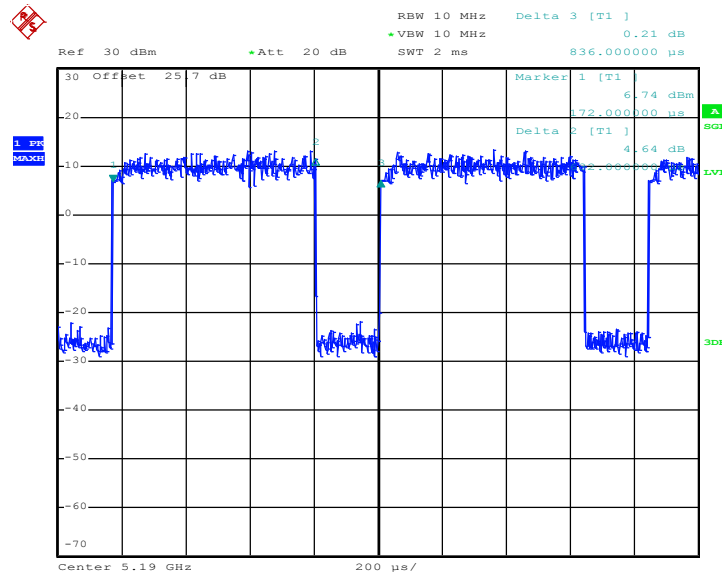

Date: 22.MAY.2016 09:23:04



## **Appendix D. Original Report**

Please refer to Sporton report number FR651612D as below.



# FCC RF Test Report

**APPLICANT** : Motorola Mobility, LLC  
**EQUIPMENT** : Mobile Cellular Phone  
**BRAND NAME** : Motorola  
**MODEL NAME** : 5892  
**FCC ID** : IHDT56VC1  
**STANDARD** : FCC Part 15 Subpart E §15.407  
**CLASSIFICATION** : (NII) Unlicensed National Information Infrastructure

The product was received on May 16, 2016 and testing was completed on Jun. 22, 2016. We, SPORTON INTERNATIONAL INC., would like to declare that the tested sample has been evaluated in accordance with the test procedures and has been in compliance with the applicable technical standards.

The test results in this report apply exclusively to the tested model / sample. Without written approval of SPORTON INTERNATIONAL INC., the test report shall not be reproduced except in full.

Reviewed by: Joseph Lin / Supervisor

Approved by: Jones Tsai / Manager



## **SPORTON INTERNATIONAL INC.**

**No. 52, Hwa Ya 1<sup>st</sup> Rd., Hwa Ya Technology Park, Kwei-Shan District, Tao Yuan City, Taiwan, R.O.C.**



# TABLE OF CONTENTS

**SUMMARY OF TEST RESULT ..... 4**

**1 GENERAL DESCRIPTION ..... 5**

1.1 Applicant ..... 5

1.2 Manufacturer ..... 5

1.3 Product Feature of Equipment Under Test ..... 5

1.4 Product Specification of Equipment Under Test ..... 6

1.5 Modification of EUT ..... 6

1.6 Testing Location ..... 7

1.7 Applicable Standards ..... 8

**2 TEST CONFIGURATION OF EQUIPMENT UNDER TEST ..... 9**

2.1 Carrier Frequency Channel ..... 9

2.2 Pre-Scanned RF Power ..... 10

2.3 Test Mode ..... 11

2.4 Connection Diagram of Test System ..... 12

2.5 Support Unit used in test configuration and system ..... 13

2.6 EUT Operation Test Setup ..... 13

2.7 Measurement Results Explanation Example ..... 13

**3 TEST RESULT ..... 14**

3.1 26dB & 99% Occupied Bandwidth Measurement ..... 14

3.2 Maximum Conducted Output Power Measurement ..... 16

3.3 Power Spectral Density Measurement ..... 18

3.4 Unwanted Radiated Emission Measurement ..... 21

3.5 AC Conducted Emission Measurement ..... 26

3.6 Frequency Stability Measurement ..... 30

3.7 Automatically Discontinue Transmission ..... 31

3.8 Antenna Requirements ..... 32

**4 LIST OF MEASURING EQUIPMENTS ..... 33**

**5 UNCERTAINTY OF EVALUATION ..... 34**

**APPENDIX A. CONDUCTED TEST RESULTS**

**APPENDIX B. RADIATED SPURIOUS EMISSION**

**APPENDIX C. RADIATED SPURIOUS EMISSION PLOTS**

**APPENDIX D. DUTY CYCLE PLOTS**



### REVISION HISTORY

REPORT NO.	VERSION	DESCRIPTION	ISSUED DATE
FR651612D	Rev. 01	Initial issue of report	Jun. 28, 2016



### SUMMARY OF TEST RESULT

Report Section	FCC Rule	Description	Limit	Result	Remark
3.1	2.1049 15.403(i)	26dB & 99% Bandwidth	-	Pass	-
3.2	15.407(a)	Maximum Conducted Output Power	≤ 24 dBm (depend on band)	Pass	-
3.3	15.407(a)	Power Spectral Density	≤ 11 dBm (depend on band)	Pass	-
3.4	15.407(b)	Unwanted Emissions	≤ -17, -27 dBm (depend on band)&15.209(a)	Pass	Under limit 0.77 dB at 5469.200 MHz
3.5	15.207	AC Conducted Emission	15.207(a)	Pass	Under limit 20.60 dB at 0.158 MHz
3.6	15.407(g)	Frequency Stability	Within Operation Band	Pass	-
3.7	15.407(c)	Automatically Discontinue Transmission	Discontinue Transmission	Pass	-
3.8	15.203 & 15.407(a)	Antenna Requirement	N/A	Pass	-



# 1 General Description

## 1.1 Applicant

**Motorola Mobility, LLC**

222 W Merchandise Mart Plaza, Suite 1800, Chicago, IL 60654, United States

## 1.2 Manufacturer

**Motorola Mobility, LLC**

222 W Merchandise Mart Plaza, Suite 1800, Chicago, IL 60654, United States

## 1.3 Product Feature of Equipment Under Test

Product Feature	
Equipment	Mobile Cellular Phone
Brand Name	Motorola
Model Name	5892
FCC ID	IHDT56VC1
IMEI Code	354130070011751 (for Radiation) 354130070013450 (for Conduction)
EUT supports Radios application	CDMA/EV-DO/GSM/EGPRS/WCDMA/HSPA/LTE/NFC WLAN 11b/g/n HT20 WLAN 11a/n HT20/HT40 Bluetooth v3.0 EDR Bluetooth v4.0 LE
EUT Stage	Identical Prototype

**Remark:** The above EUT's information was declared by manufacturer. Please refer to the specifications or user's manual for more detailed description.

Accessory List	
AC Adapter	Brand Name : Motorola
	Model Name : SPN5913A
Battery 1	Brand Name : Motorola
	Model Name : SNN5974A
Battery 2	Brand Name : Motorola
	Model Name : SNN5975A
Earphone	Brand Name : Motorola
	Model Name : SJYN1181B
USB Cable	Brand Name : Motorola
	Model Name : SKN6473A



### 1.4 Product Specification of Equipment Under Test

Standards-related Product Specification	
<b>Tx/Rx Frequency Range</b>	5180 MHz ~ 5240 MHz 5260 MHz ~ 5320 MHz 5500 MHz ~ 5580 MHz 5660 MHz ~ 5700 MHz
<b>Maximum Output Power to Antenna</b>	<b>&lt;5180 MHz ~ 5240 MHz&gt;</b> 802.11a : 15.77 dBm / 0.0378 W 802.11n HT20 : 14.58 dBm / 0.0287 W 802.11n HT40 : 13.87 dBm / 0.0244 W <b>&lt;5260 MHz ~ 5320 MHz&gt;</b> 802.11a : 16.07 dBm / 0.0405 W 802.11n HT20 : 14.70 dBm / 0.0295 W 802.11n HT40 : 14.33 dBm / 0.0271 W <b>&lt;5500 MHz ~ 5580 MHz and 5660 MHz ~ 5700 MHz &gt;</b> 802.11a : 15.88 dBm / 0.0387 W 802.11n HT20 : 14.48 dBm / 0.0281 W 802.11n HT40 : 14.90 dBm / 0.0309 W
<b>99% Occupied Bandwidth</b>	802.11a : 19.55 MHz 802.11n HT20 : 19.40 MHz 802.11n HT40 : 37.10 MHz
<b>Antenna Type</b>	ILA Antenna (The antenna peak gain of EUT is less than 6 dBi)
<b>Type of Modulation</b>	OFDM (BPSK / QPSK / 16QAM / 64QAM)

### 1.5 Modification of EUT

No modifications are made to the EUT during all test items.



### 1.6 Testing Location

Sporton Lab is accredited to ISO 17025 by Taiwan Accreditation Foundation (TAF code : 1190) and the FCC designation No. TW1022 under the FCC 2.948(e) by Mutual Recognition Agreement (MRA) in FCC Test.

<b>Test Site</b>	SPORTON INTERNATIONAL INC.	
<b>Test Site Location</b>	No. 52, Hwa Ya 1 <sup>st</sup> Rd., Hwa Ya Technology Park, Kwei-Shan District, Tao Yuan City, Taiwan, R.O.C. TEL: +886-3-327-3456 FAX: +886-3-328-4978	
<b>Test Site No.</b>	<b>Sporton Site No.</b>	
	TH05-HY	CO05-HY

**Note:** The test site complies with ANSI C63.4 2014 requirement.

<b>Test Site</b>	SPORTON INTERNATIONAL INC.	
<b>Test Site Location</b>	No.58, Aly. 75, Ln. 564, Wenhua 3rd Rd. Guishan Dist, Taoyuan City, Taiwan (R.O.C.) TEL: +886-3-327-0868 FAX: +886-3-327-0855	
<b>Test Site No.</b>	<b>Sporton Site No.</b>	
	03CH11-HY	

**Note:** The test site complies with ANSI C63.4 2014 requirement.



## 1.7 Applicable Standards

According to the specifications of the manufacturer, the EUT must comply with the requirements of the following standards:

- ♦ FCC Part 15 Subpart E
- ♦ FCC KDB 789033 D02 General UNII Test Procedures New Rules v01r02
- ♦ ANSI C63.10-2013

### **Remark:**

1. All test items were verified and recorded according to the standards and without any deviation during the test.
2. This EUT has also been tested and complied with the requirements of FCC Part 15, Subpart B, recorded in a separate test report.



## 2 Test Configuration of Equipment Under Test

The EUT has been associated with peripherals and configuration operated in a manner tended to maximize its emission characteristics in a typical application. Frequency range investigated: conducted emission (150 kHz to 30 MHz) and radiated emission (9 kHz to the 10th harmonic of the highest fundamental frequency or to 40 GHz, whichever is lower). For radiated measurement, pre-scanned in three orthogonal panels, X, Y, Z. The worst cases (X plane) were recorded in this report.

The final configuration from all the combinations and the worst-case data rates were investigated by measuring the maximum power across all the data rates and modulation modes under section 2.2.

Based on the worst configuration found above, the RF power setting is set individually to meet FCC compliance limit for the final conducted and radiated tests shown in section 2.3.

### 2.1 Carrier Frequency Channel

Frequency Band	Channel	Freq. (MHz)	Channel	Freq. (MHz)
5150-5250 MHz Band 1 (U-NII-1)	36	5180	44	5220
	<b>38</b>	<b>5190</b>	<b>46</b>	<b>5230</b>
	40	5200	48	5240

Frequency Band	Channel	Freq. (MHz)	Channel	Freq. (MHz)
5250-5350 MHz Band 2 (U-NII-2A)	52	5260	60	5300
	<b>54</b>	<b>5270</b>	<b>62</b>	<b>5310</b>
	56	5280	64	5320

Frequency Band	Channel	Freq. (MHz)	Channel	Freq. (MHz)
5470-5600 MHz and 5650-5725 MHz Band 3 (U-NII-2C)	100	5500	116	5580
	<b>102</b>	<b>5510</b>	132	5660
	104	5520	<b>134</b>	<b>5670</b>
	108	5540	136	5680
	<b>110</b>	<b>5550</b>	140	5700
	112	5560		

**Note:** The above Frequency and Channel in boldface were 802.11n HT40.



## 2.2 Pre-Scanned RF Power

Preliminary tests were performed in different data rate and data rate associated with the highest power were chosen for full test in the following tables. Final Output Power equals to Measured Output Power adds the duty factor.

Channel	Frequency	5GHz 802.11a Average Power (dBm)							
		Data Rate							
		6 Mbps	9 Mbps	12 Mbps	18 Mbps	24 Mbps	36 Mbps	48 Mbps	54 Mbps
CH 36	5180 MHz	15.77	15.32	15.26	15.26	15.29	14.49	13.39	12.50
CH 44	5220 MHz	15.49	14.81	14.82	14.90	14.89	14.02	12.99	12.32
CH 48	5240 MHz	15.65	15.35	15.22	15.18	15.26	14.46	13.42	12.60
CH 52	5260 MHz	16.07	15.24	15.27	15.23	15.38	14.47	13.48	12.69
CH 60	5300 MHz	15.69	15.00	15.02	15.06	15.10	14.28	13.27	12.44
CH 64	5320 MHz	15.65	15.14	15.14	15.08	15.20	14.44	13.42	12.69
CH 100	5500 MHz	15.72	15.36	15.40	15.37	15.39	14.59	13.46	12.67
CH 116	5580 MHz	15.88	15.53	14.55	15.57	15.56	14.84	13.73	13.00
CH 140	5700 MHz	15.61	15.14	15.07	15.16	15.17	14.35	13.21	12.39

Channel	Frequency	5GHz 802.11n HT20 Average Power (dBm)							
		Data Rate							
		MCS0	MCS1	MCS2	MCS3	MCS4	MCS5	MCS6	MCS7
CH 36	5180 MHz	14.49	14.47	14.48	14.46	14.47	13.64	12.87	11.88
CH 44	5220 MHz	14.03	13.99	13.99	13.99	13.91	13.14	12.32	11.34
CH 48	5240 MHz	14.58	14.49	14.42	14.53	14.39	13.46	12.66	11.91
CH 52	5260 MHz	14.70	14.68	14.66	14.65	14.65	13.71	12.99	11.95
CH 60	5300 MHz	14.32	14.29	14.19	14.25	14.29	13.51	12.62	11.69
CH 64	5320 MHz	14.39	14.33	14.28	14.35	14.37	13.57	12.74	11.76
CH 100	5500 MHz	14.38	14.37	14.34	14.34	14.36	13.64	12.60	11.70
CH 116	5580 MHz	14.48	14.43	14.44	14.45	14.47	13.64	12.75	11.75
CH 140	5700 MHz	14.11	14.06	14.07	14.10	14.10	13.32	12.38	11.36

Channel	Frequency	5GHz 802.11n HT40 Average Power (dBm)							
		Data Rate							
		MCS0	MCS1	MCS2	MCS3	MCS4	MCS5	MCS6	MCS7
CH 38	5190MHz	13.47	13.40	13.45	13.45	13.45	13.46	12.53	11.77
CH 46	5230MHz	13.87	13.76	13.83	13.83	13.08	13.20	12.29	11.48
CH 54	5270MHz	14.33	14.17	14.16	14.19	13.38	13.29	12.35	11.43
CH 62	5310MHz	12.52	12.49	12.48	12.49	12.49	12.47	12.50	11.91
CH 102	5510MHz	14.05	13.95	14.02	14.03	13.78	13.62	12.71	11.77
CH 110	5550MHz	14.44	14.39	14.41	14.34	13.47	13.47	12.48	11.63
CH 134	5670MHz	14.90	14.53	14.70	14.57	13.70	13.60	12.51	11.57



## 2.3 Test Mode

Final test mode of conducted test items and radiated spurious emissions are considering the modulation and worse data rates from the power table described in section 2.2.

Modulation	Data Rate
802.11a	6 Mbps
802.11n HT20	MCS0
802.11n HT40	MCS0

<b>AC Conducted Emission</b>	Mode 1 : GSM850 Idle + Bluetooth Link + WLAN (5GHz) Link + Earphone + MP3 + Adapter
--------------------------------------	---

Ch. #		Band I : 5150-5250 MHz	Band II : 5250-5350 MHz	Band III : 5470-5600 MHz and 5650-5725MHz
		802.11a	802.11a	802.11a
L	Low	36	52	100
M	Middle	44	60	116
H	High	48	64	140

Ch. #		Band I : 5150-5250 MHz	Band II : 5250-5350 MHz	Band III : 5470-5600 MHz and 5650-5725MHz
		802.11n HT20	802.11n HT20	802.11n HT20
L	Low	36	52	100
M	Middle	44	60	116
H	High	48	64	140

Ch. #		Band I : 5150-5250 MHz	Band II : 5250-5350 MHz	Band III : 5470-5600 MHz and 5650-5725MHz
		802.11n HT40	802.11n HT40	802.11n HT40
L	Low	38	54	102
M	Middle	-	-	110
H	High	46	62	134

## 2.4 Connection Diagram of Test System

<WLAN Tx Mode>

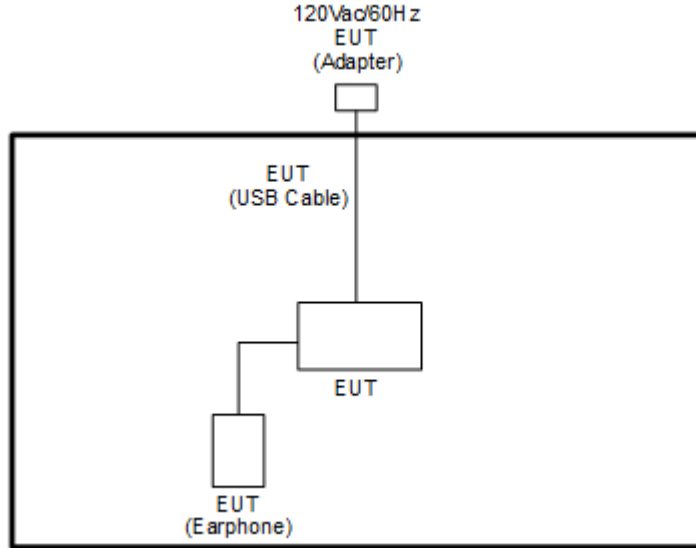

<AC Conducted Emission Mode>

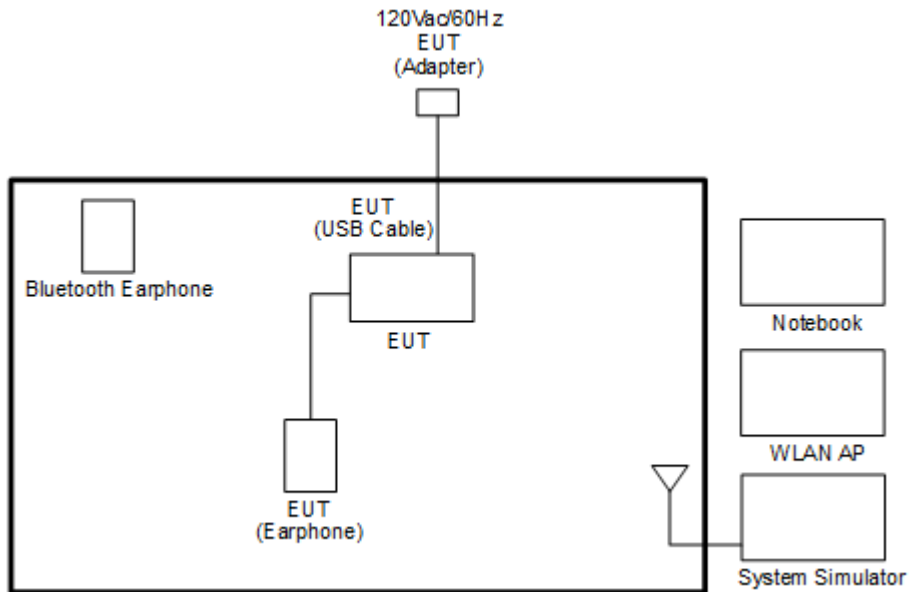



## 2.5 Support Unit used in test configuration and system

Item	Equipment	Trade Name	Model Name	FCC ID	Data Cable	Power Cord
1.	System Simulator	Anritsu	MT8820C	N/A	N/A	Unshielded, 1.8 m
2.	WLAN AP	D-Link	DIR-865L	KA2IR865LA1	N/A	Unshielded, 1.8 m
3.	Notebook	DELL	Latitude E6320	FCC DoC/ Contains FCC ID: QDS-BRCM1054	N/A	AC I/P: Unshielded, 1.2 m DC O/P: Shielded, 1.8 m
4.	Bluetooth Earphone	Sony Ericsson	MW600	PY7DDA-2029	N/A	N/A
5.	SD Card	SanDisk	MicroSD HC	FCC DoC	N/A	N/A

## 2.6 EUT Operation Test Setup

For WLAN function, programmed RF utility, "QRCT" installed in the notebook make the EUT provide functions like channel selection and power level for continuous transmitting and receiving signals.

## 2.7 Measurement Results Explanation Example

For all conducted test items:

The offset level is set in the spectrum analyzer to compensate the RF cable loss and attenuator factor between EUT conducted output port and spectrum analyzer. With the offset compensation, the spectrum analyzer reading level is exactly the EUT RF output level.

Example :

The spectrum analyzer offset is derived from RF cable loss and attenuator factor.

*Offset = RF cable loss + attenuator factor.*

Following shows an offset computation example with cable loss 4.2 dB and 10dB attenuator.

$$\begin{aligned} \text{Offset(dB)} &= \text{RF cable loss(dB)} + \text{attenuator factor(dB)}. \\ &= 4.2 + 10 = 14.2 \text{ (dB)} \end{aligned}$$

### 3 Test Result

#### 3.1 26dB & 99% Occupied Bandwidth Measurement

##### 3.1.1 Description of 26dB & 99% Occupied Bandwidth

This section is for reporting purpose only.

There is no restriction limits for bandwidth.

##### 3.1.2 Measuring Instruments

The measuring equipment is listed in the section 4 of this test report.

##### 3.1.3 Test Procedures

1. The testing follows FCC KDB 789033 D02 General UNII Test Procedures New Rules v01r02.  
Section C) Emission bandwidth
2. Set RBW = approximately 1% of the emission bandwidth.
3. Set the VBW > RBW.
4. Detector = Peak.
5. Trace mode = max hold
6. Measure the maximum width of the emission that is 26 dB down from the peak of the emission.  
Compare this with the RBW setting of the analyzer. Readjust RBW and repeat measurement as needed until the RBW/EBW ratio is approximately 1%.
7. For 99% Bandwidth Measurement, the spectrum analyzer's resolution bandwidth (RBW) is set 1MHz and set the Video bandwidth (VBW)  $\geq 3 * RBW$ .
8. Measure and record the results in the test report.

##### 3.1.4 Test Setup

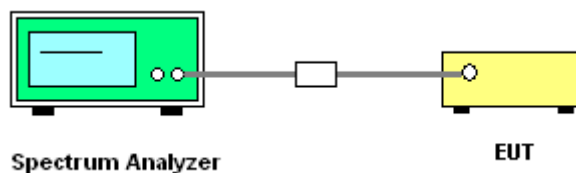



### 3.1.5 Test Result of 26dB & 99% Occupied Bandwidth Plots

Please refer to Appendix A.

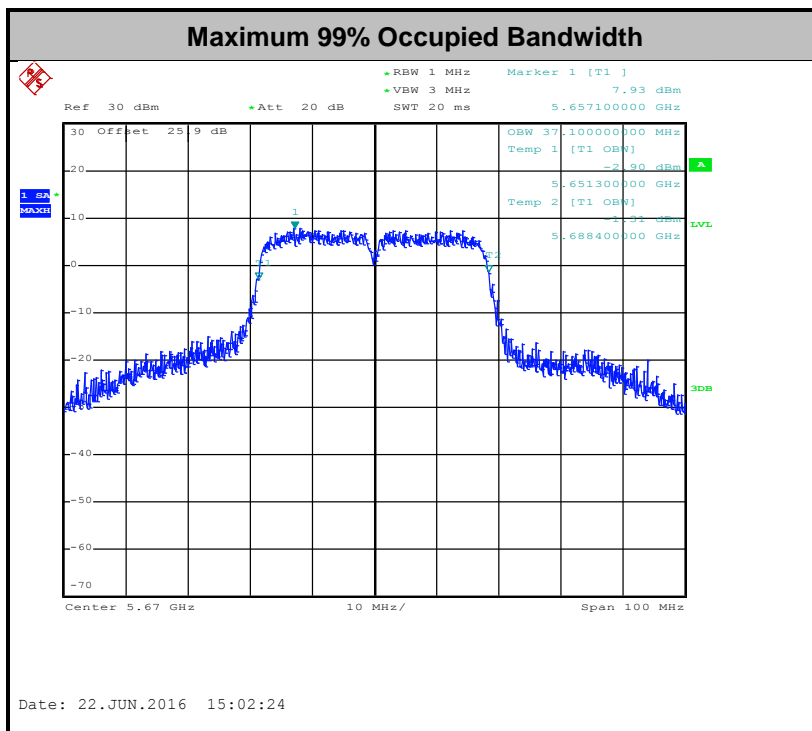
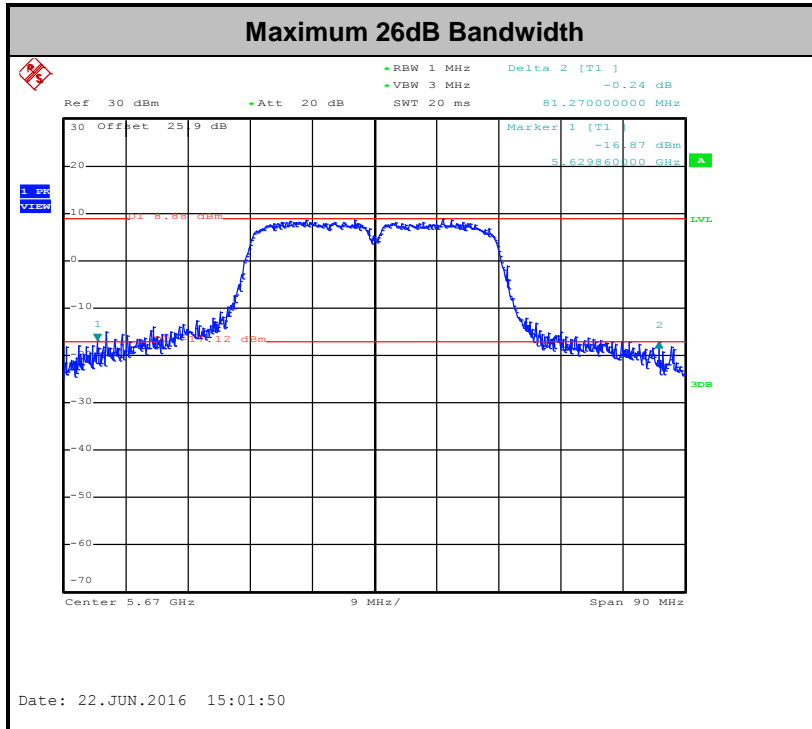



## 3.2 Maximum Conducted Output Power Measurement

### 3.2.1 Limit of Maximum Conducted Output Power

<FCC 14-30 CFR 15.407>

For mobile and portable client devices in the 5.15–5.25 GHz band, the maximum conducted output power over the frequency band of operation shall not exceed 250 mW.

For the 5.25–5.35 GHz and 5.47–5.725 GHz bands, the maximum conducted output power over the frequency bands of operation shall not exceed the lesser of 250 mW or  $11 \text{ dBm} + 10 \log B$ , where B is the 26 dB emission bandwidth in megahertz.

If transmitting antennas of directional gain greater than 6 dBi are used, the peak output power shall be reduced by the amount in dB that the directional gain of the antenna exceeds 6 dBi.

Note that U-NII-2 band, devices with a maximum e.i.r.p. greater than 500 mW shall implement TPC in order to have the capability to operate at least 6 dB below the maximum permitted e.i.r.p. of 1 W.

### 3.2.2 Measuring Instruments

The measuring equipment is listed in the section 4 of this test report.

### 3.2.3 Test Procedures

The testing follows Method PM of FCC KDB 789033 D02 General UNII Test Procedures New Rules v01r02.

Method PM (Measurement using an RF average power meter):

1. Measurement is performed using a wideband RF power meter.
2. The EUT is configured to transmit continuously with a consistent duty cycle at its maximum power control level.
3. Measure the average power of the transmitter, and the average power is corrected with duty factor,  $10 \log(1/x)$ , where  $x$  is the duty cycle.

### 3.2.4 Test Setup

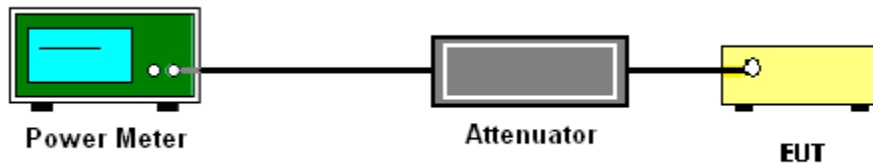

### 3.2.5 Test Result of Maximum Conducted Output Power

Please refer to Appendix A.



### **3.3 Power Spectral Density Measurement**

#### **3.3.1 Limit of Power Spectral Density**

**<FCC 14-30 CFR 15.407>**

For mobile and portable client devices in the 5.15–5.25 GHz band, the maximum power spectral density shall not exceed 11dBm in any 1 megahertz band.

For the 5.25–5.35 GHz and 5.47–5.725 GHz bands, the maximum power spectral density shall not exceed 11 dBm in any 1 megahertz band.

If transmitting antennas of directional gain greater than 6 dBi are used, the peak output power shall be reduced by the amount in dB that the directional gain of the antenna exceeds 6 dBi.

#### **3.3.2 Measuring Instruments**

The measuring equipment is listed in the section 4 of this test report.

### 3.3.3 Test Procedures

The testing follows FCC KDB 789033 D02 General UNII Test Procedures New Rules v01r02.  
Section F) Maximum power spectral density.

#### # Method SA-2 #

(trace averaging across on and off times of the EUT transmissions, followed by duty cycle correction).

1. The testing follows Method SA-2 of FCC KDB 789033 D02 General UNII Test Procedures New Rules v01r02.
  - Measure the duty cycle.
  - Set span to encompass the entire emission bandwidth (EBW) of the signal.
  - Set RBW = 1 MHz.
  - Set VBW  $\geq$  3 MHz.
  - Number of points in sweep  $\geq$  2 Span / RBW.
  - Sweep time = auto.
  - Detector = RMS
  - Trace average at least 100 traces in power averaging mode.
  - Add  $10 \log(1/x)$ , where x is the duty cycle, to the measured power in order to compute the average power during the actual transmission times. For example, add  $10 \log(1/0.25) = 6$  dB if the duty cycle is 25 percent.
2. The RF output of EUT was connected to the spectrum analyzer by a low loss cable.
3. Each plot has already offset with cable loss, and attenuator loss. Measure the PPSD and record it.

### 3.3.4 Test Setup

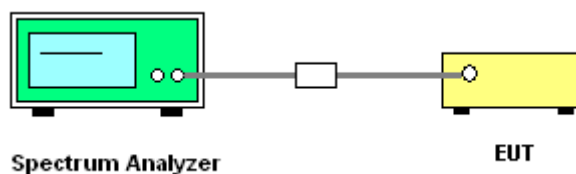



### 3.3.5 Test Result of Power Spectral Density

Please refer to Appendix A.

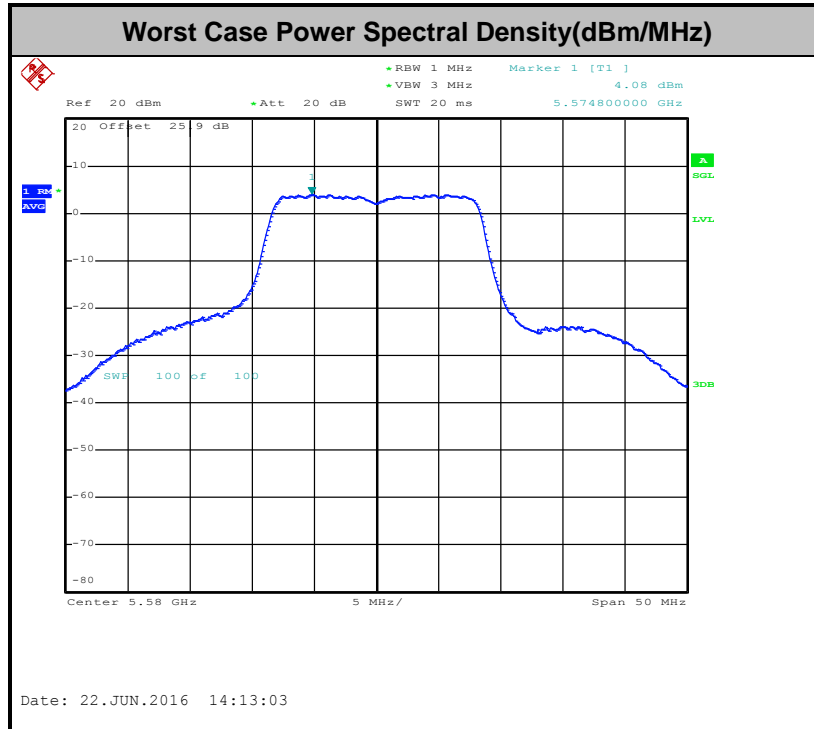

**Note:** Average Power Density (dB) = Measured value+ Duty Factor



### 3.4 Unwanted Radiated Emission Measurement

This section as specified in FCC Part 15.407(b) is to measure unwanted emissions through radiated measurement for band edge spurious emissions and out of band emissions measurement. The unwanted emissions shall comply with 15.407(b)(1) to (6), and restricted bands per FCC Part15.205.

#### 3.4.1 Limit of Unwanted Emissions

- (1) For transmitters operating in the 5150-5250 MHz band: all emissions outside of the 5150-5350 MHz band shall not exceed an EIRP of -27dBm/MHz.  
 For transmitters operating in the 5250-5350 MHz band: all emissions outside of the 5150-5350 MHz band shall not exceed an EIRP of -27 dBm/MHz. Devices operating in the 5250-5350 MHz band that generate emissions in the 5150-5250 MHz band must meet all applicable technical requirements for operation in the 5150-5250 MHz band (including indoor use) or alternatively meet an out-of-band emission EIRP limit of -27 dBm/MHz in the 5150-5250 MHz band.  
 For transmitters operating in the 5470-5600 MHz and 5650-5725MHz band: all emissions outside of the 5470-5600 MHz and 5650-5725MHz band shall not exceed an EIRP of -27 dBm/MHz.
- (2) Unwanted spurious emissions fallen in restricted bands per FCC Part15.205 shall comply with the general field strength limits set forth in § 15.209 as below table,

Frequency (MHz)	Field Strength (microvolts/meter)	Measurement Distance (meters)
0.009 – 0.490	2400/F(kHz)	300
0.490 – 1.705	24000/F(kHz)	30
1.705 – 30.0	30	30
30 – 88	100	3
88 – 216	150	3
216 - 960	200	3
Above 960	500	3

**Note:** The following formula is used to convert the EIRP to field strength.

$$E = \frac{1000000\sqrt{30P}}{3} \mu\text{V/m, where P is the eirp (Watts)}$$

EIRP (dBm)	Field Strength at 3m (dBμV/m)
-17	78.3
- 27	68.3



- (3) KDB789033 D01 v01r02 G)2)c) As specified in 15.407(b), emissions above 1000 MHz that are outside of the restricted bands are subject to a peak emission limit of -27 dBm/MHz (or -17 dBm/MHz as specified in 15.407(b)(4)). However, an out-of-band emission that complies with both the average and peak limits of 15.209 is not required to satisfy the -27 dBm/MHz or -17 dBm/MHz peak emission limit.

### **3.4.2 Measuring Instruments**

The measuring equipment is listed in the section 4 of this test report.

### **3.4.3 Test Procedures**

1. The testing follows FCC KDB 789033 D02 General UNII Test Procedures New Rules v01r02. Section G) Unwanted emissions measurement.
  - (1) Procedure for Unwanted Emissions Measurements Below 1000MHz
    - RBW = 120 kHz
    - VBW = 300 kHz
    - Detector = Peak
    - Trace mode = max hold
  - (2) Procedure for Peak Unwanted Emissions Measurements Above 1000 MHz
    - RBW = 1 MHz
    - VBW  $\geq$  3 MHz
    - Detector = Peak
    - Sweep time = auto
    - Trace mode = max hold
  - (3) Procedures for Average Unwanted Emissions Measurements Above 1000MHz
    - RBW = 1 MHz
    - VBW = 10 Hz, when duty cycle is no less than 98 percent.
    - VBW  $\geq$  1/T, when duty cycle is less than 98 percent where T is the minimum transmission duration over which the transmitter is on and is transmitting at its maximum power control level for the tested mode of operation.

2. The EUT was placed on a turntable with 0.8 meter for frequency below 1GHz and 1.5 meter for frequency above 1GHz respectively above ground.
3. The EUT was set 3 meters from the interference receiving antenna which was mounted on the top of a variable height antenna tower.
4. The antenna is a broadband antenna and its height is adjusted between one meter and four meters above ground to find the maximum value of the field strength for both horizontal polarization and vertical polarization of the antenna.
5. For each suspected emission, the EUT was arranged to its worst case and then adjust the antenna tower (from 1 m to 4 m) and turntable (from 0 degree to 360 degrees) to find the maximum reading.
6. For testing below 1GHz, if the emission level of the EUT in peak mode was 3 dB lower than the limit specified, then peak values of EUT will be reported, otherwise, the emissions will be repeated one by one using the CISPR quasi-peak method and reported.
7. For testing above 1GHz, the emission level of the EUT in peak mode was 20dB lower than average limit (that means the emission level in average mode also complies with the limit in average mode), then peak values of EUT will be reported, otherwise, the emissions will be measured in average mode again and reported.

### 3.4.4 Test Setup

For radiated emissions below 30MHz

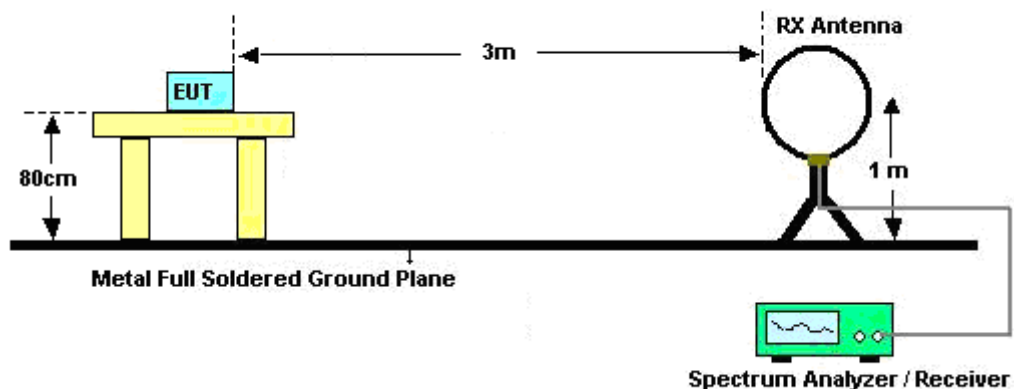

For radiated emissions from 30MHz to 1GHz

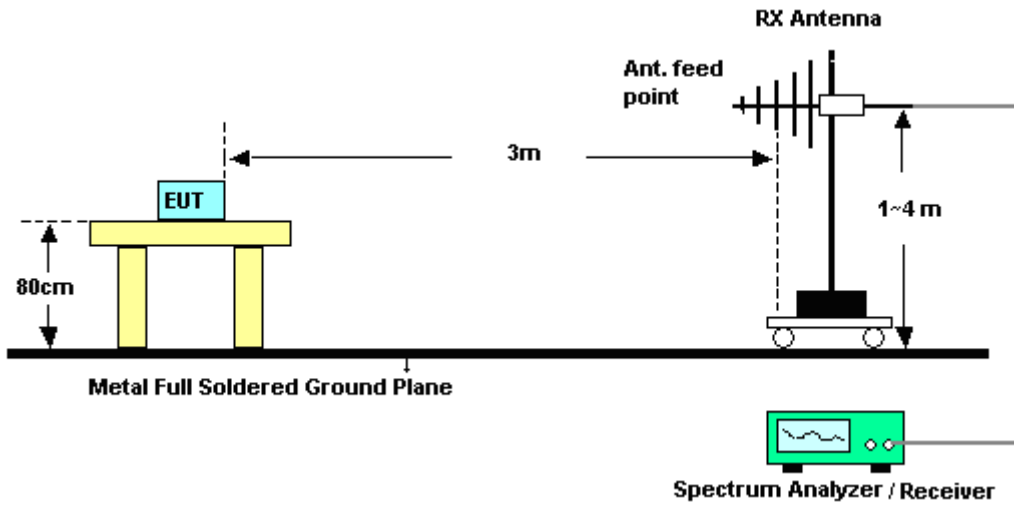

For radiated emissions above 1GHz

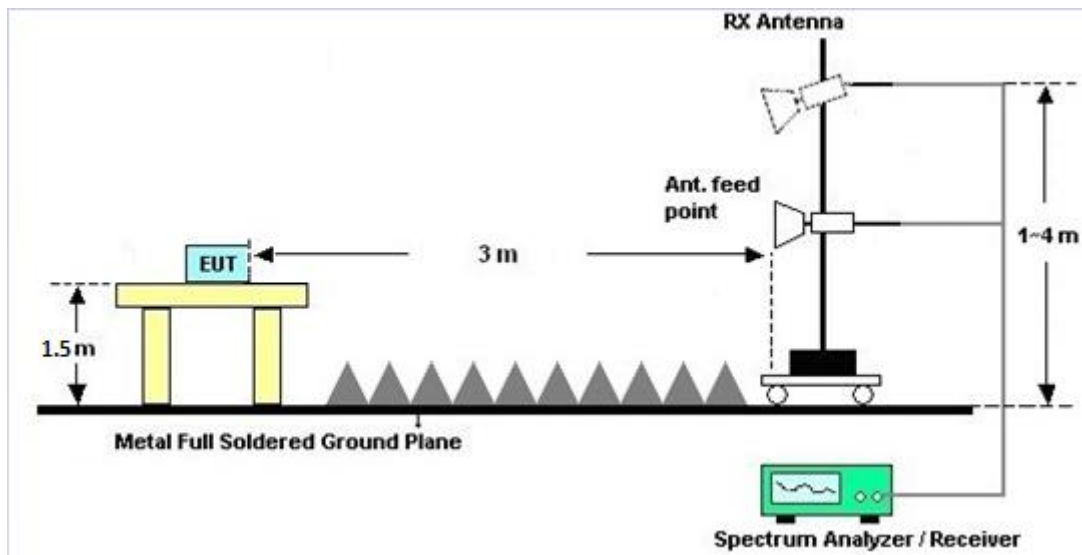



### **3.4.5 Test Results of Radiated Emissions (9 kHz ~ 30 MHz)**

The low frequency, which started from 9 kHz to 30MHz, was pre-scanned and the result which was 20dB lower than the limit line per 15.31(o) was not reported.

### **3.4.6 Test Result of Radiated Band Edges**

Please refer to Appendix B and C.

### **3.4.7 Duty Cycle**

Please refer to Appendix D.

### **3.4.8 Test Result of Unwanted Radiated Emission (30MHz ~ 10th Harmonic)**

Please refer to Appendix B and C.



### 3.5 AC Conducted Emission Measurement

#### 3.5.1 Limit of AC Conducted Emission

For equipment that is designed to be connected to the public utility (AC) power line, the radio frequency voltage that is conducted back onto the AC power line on any frequency or frequencies within the band 150 kHz to 30 MHz shall not exceed the limits in the following table.

Frequency of emission (MHz)	Conducted limit (dBµV)	
	Quasi-peak	Average
0.15-0.5	66 to 56*	56 to 46*
0.5-5	56	46
5-30	60	50

\*Decreases with the logarithm of the frequency.

#### 3.5.2 Measuring Instruments

The measuring equipment is listed in the section 4 of this test report.

#### 3.5.3 Test Procedures

1. The EUT was placed 0.4 meter from the conducting wall of the shielding room was kept at least 80 centimeters from any other grounded conducting surface.
2. Connect EUT to the power mains through a line impedance stabilization network (LISN).
3. All the support units are connecting to the other LISN.
4. The LISN provides 50 ohm coupling impedance for the measuring instrument.
5. The FCC states that a 50 ohm, 50 microhenry LISN should be used.
6. Both sides of AC line were checked for maximum conducted interference.
7. The frequency range from 150 kHz to 30 MHz was searched.
8. Set the test-receiver system to Peak Detect Function and specified bandwidth with Maximum Hold Mode.

### 3.5.4 Test Setup

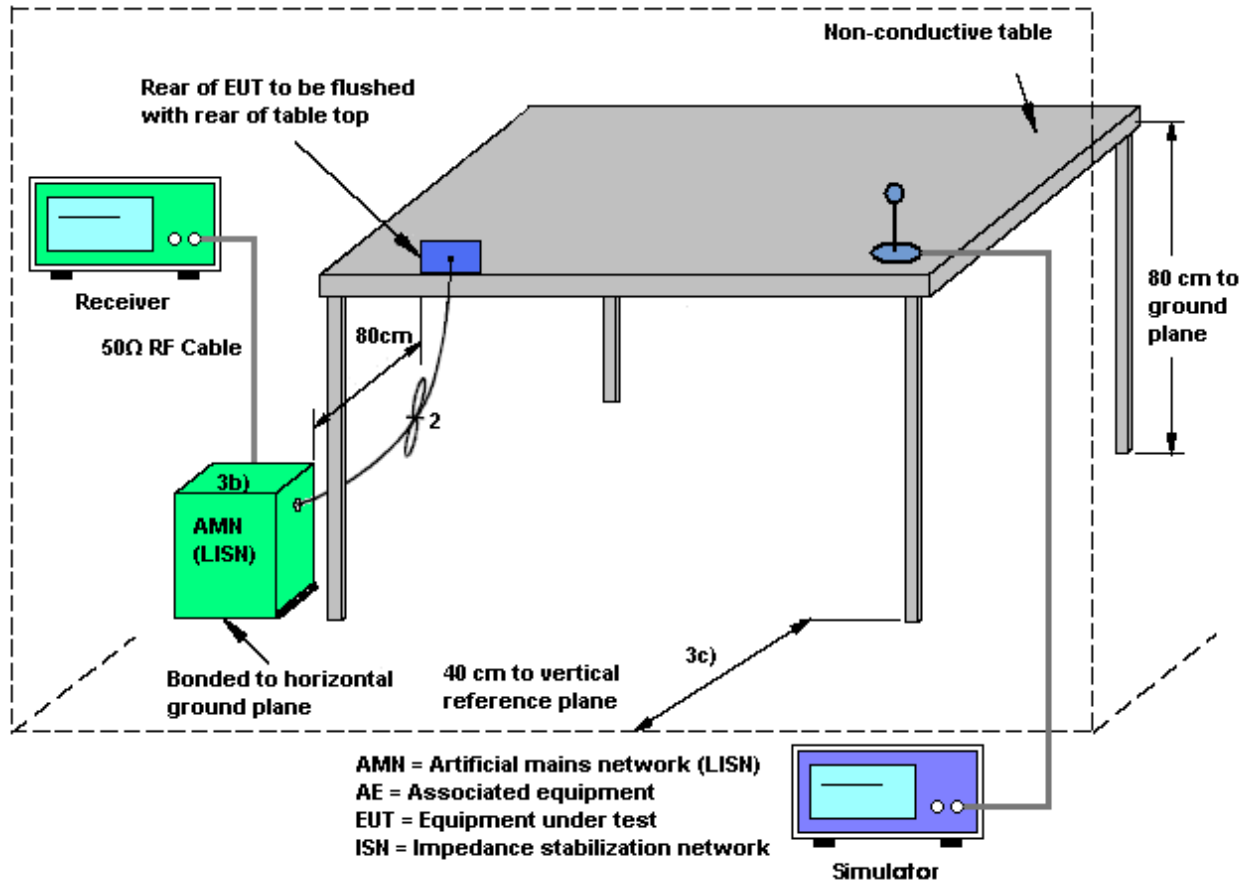



### 3.5.5 Test Result of AC Conducted Emission

Test Mode :	Mode 1	Temperature :	25~26°C
Test Engineer :	Kai-Chun Chu	Relative Humidity :	51~52%
Test Voltage :	120Vac / 60Hz	Phase :	Line
Function Type :	GSM850 Idle + Bluetooth Link + WLAN (5GHz) Link + Earphone + MP3 + Adapter		

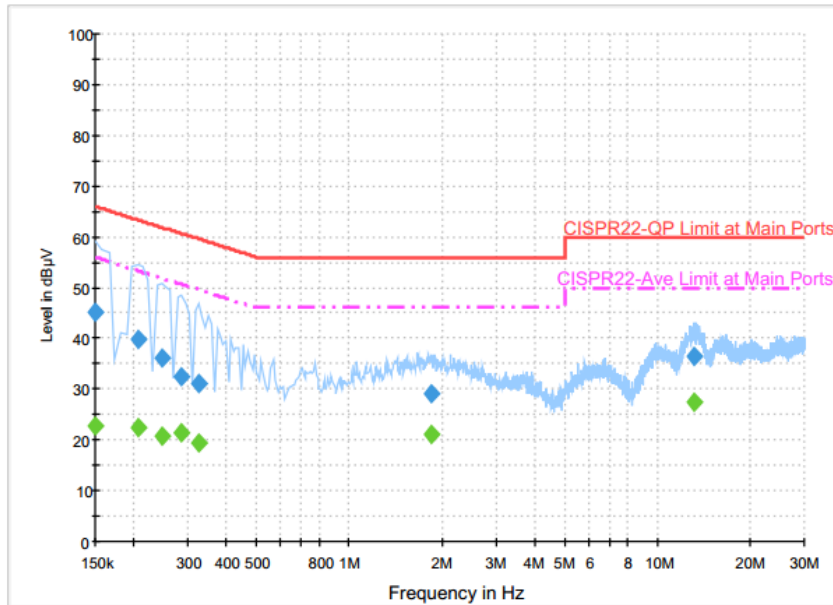

**Final Result : QuasiPeak**

Frequency (MHz)	QuasiPeak (dBµV)	Filter	Line	Corr. (dB)	Margin (dB)	Limit (dBµV)
0.150000	45.3	Off	L1	19.6	20.7	66.0
0.206000	39.6	Off	L1	19.6	23.8	63.4
0.246000	36.1	Off	L1	19.6	25.8	61.9
0.286000	32.4	Off	L1	19.6	28.2	60.6
0.326000	31.3	Off	L1	19.6	28.3	59.6
1.854000	29.2	Off	L1	19.7	26.8	56.0
13.254000	36.6	Off	L1	20.3	23.4	60.0

**Final Result : Average**

Frequency (MHz)	Average (dBµV)	Filter	Line	Corr. (dB)	Margin (dB)	Limit (dBµV)
0.150000	22.7	Off	L1	19.6	33.3	56.0
0.206000	22.6	Off	L1	19.6	30.8	53.4
0.246000	20.9	Off	L1	19.6	31.0	51.9
0.286000	21.5	Off	L1	19.6	29.1	50.6
0.326000	19.4	Off	L1	19.6	30.2	49.6
1.854000	21.1	Off	L1	19.7	24.9	46.0
13.254000	27.5	Off	L1	20.3	22.5	50.0



Test Mode :	Mode 1	Temperature :	25~26°C
Test Engineer :	Kai-Chun Chu	Relative Humidity :	51~52%
Test Voltage :	120Vac / 60Hz	Phase :	Neutral
Function Type :	GSM850 Idle + Bluetooth Link + WLAN (5GHz) Link + Earphone + MP3 + Adapter		

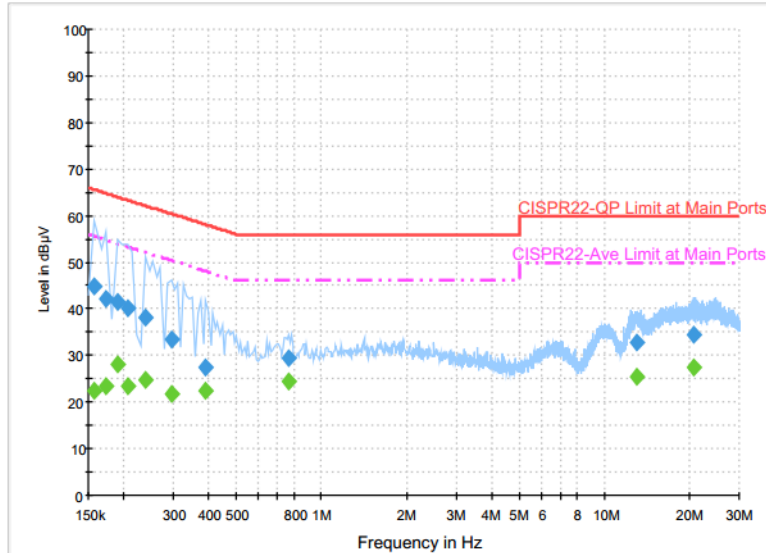

**Final Result : QuasiPeak**

Frequency (MHz)	QuasiPeak (dBµV)	Filter	Line	Corr. (dB)	Margin (dB)	Limit (dBµV)
0.158000	45.0	Off	N	19.6	20.6	65.6
0.174000	42.2	Off	N	19.6	22.6	64.8
0.190000	41.6	Off	N	19.6	22.4	64.0
0.206000	40.1	Off	N	19.6	23.3	63.4
0.238000	38.0	Off	N	19.6	24.2	62.2
0.294000	33.5	Off	N	19.6	26.9	60.4
0.390000	27.5	Off	N	19.6	30.6	58.1
0.766000	29.3	Off	N	19.6	26.7	56.0
13.102000	32.8	Off	N	20.3	27.2	60.0
20.798000	34.5	Off	N	20.8	25.5	60.0

**Final Result : Average**

Frequency (MHz)	Average (dBµV)	Filter	Line	Corr. (dB)	Margin (dB)	Limit (dBµV)
0.158000	22.4	Off	N	19.6	33.2	55.6
0.174000	23.5	Off	N	19.6	31.3	54.8
0.190000	28.0	Off	N	19.6	26.0	54.0
0.206000	23.5	Off	N	19.6	29.9	53.4
0.238000	24.9	Off	N	19.6	27.3	52.2
0.294000	21.9	Off	N	19.6	28.5	50.4
0.390000	22.4	Off	N	19.6	25.7	48.1
0.766000	24.4	Off	N	19.6	21.6	46.0
13.102000	25.5	Off	N	20.3	24.5	50.0
20.798000	27.3	Off	N	20.8	22.7	50.0

### 3.6 Frequency Stability Measurement

#### 3.6.1 Limit of Frequency Stability

Manufacturers of U-NII devices are responsible for ensuring frequency stability such that an emission is maintained within the band of operation under all conditions of normal operation as specified in the user's manual.

#### 3.6.2 Measuring Instruments

The measuring equipment is listed in the section 4 of this test report.

#### 3.6.3 Test Procedures

1. To ensure emission at the band edge is maintained within the authorized band, those values shall be measured by radiation emissions at upper and lower frequency points, and finally compensated by frequency deviation as procedures below.
2. The EUT was operated at the maximum output power, and connected to the spectrum analyzer, which is set to maximum hold function and peak detector. The peak value of the power envelope was measured and noted. The upper and lower frequency points were respectively measured relatively 10dB lower than the measured peak value.
3. The frequency deviation was calculated by adding the upper frequency point and the lower frequency point divided by two. Those detailed values of frequency deviation are provided in table below.

#### 3.6.4 Test Setup

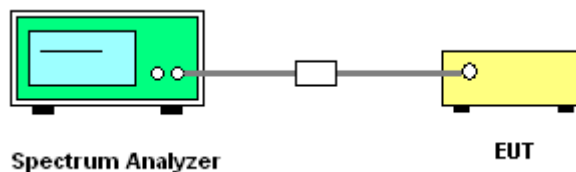

#### 3.6.5 Test Result of Frequency Stability

Please refer to Appendix A.



## **3.7 Automatically Discontinue Transmission**

### **3.7.1 Limit of Automatically Discontinue Transmission**

The device shall automatically discontinue transmission in case of either absence of information to transmit or operational failure. These provisions are not intended to preclude the transmission of control or signaling information or the use of repetitive codes used by certain digital technologies to complete frame or burst intervals. Applicants shall include in their application for equipment authorization to describe how this requirement is met.

### **3.7.2 Measuring Instruments**

The measuring equipment is listed in the section 4 of this test report.

### **3.7.3 Test Result of Automatically Discontinue Transmission**

While the EUT is not transmitting any information, the EUT can automatically discontinue transmission and become standby mode for power saving. The EUT can detect the controlling signal of ACK message transmitting from remote device and verify whether it shall resend or discontinue transmission.



## **3.8 Antenna Requirements**

### **3.8.1 Standard Applicable**

According to FCC 47 CFR Section 15.407(a)(1)(2) ,if transmitting antenna directional gain is greater than 6 dBi, both the peak transmit power and the peak power spectral density shall be reduced by the amount in dB that the directional gain of the antenna exceeds 6 dBi.

### **3.8.2 Antenna Anti-Replacement Construction**

An embedded-in antenna design is used.

### **3.8.3 Antenna Gain**

The antenna gain is less than 6 dBi. Therefore, it is not necessary to reduce maximum peak output power limit.



## 4 List of Measuring Equipments

Instrument	Manufacturer	Model No.	Serial No.	Characteristics	Calibration Date	Test Date	Due Date	Remark
Power Meter	Anritsu	ML2495A	1132003	300MHz~40GHz	Aug. 12, 2015	May 22, 2016 ~ Jun. 22, 2016	Aug. 11, 2016	Conducted (TH05-HY)
Power Sensor	Anritsu	MA2411B	1126017	300MHz~40GHz	Aug. 12, 2015	May 22, 2016 ~ Jun. 22, 2016	Aug. 11, 2016	Conducted (TH05-HY)
Spectrum Analyzer	Rohde & Schwarz	FSP30	101067	9kHz ~ 30GHz	Nov. 13, 2015	May 22, 2016 ~ Jun. 22, 2016	Nov. 12, 2016	Conducted (TH05-HY)
Temperature Chamber	ESPEC	SH-641	92013720	-40°C ~90°C	Sep. 08, 2015	May 22, 2016 ~ Jun. 22, 2016	Sep. 07, 2016	Conducted (TH05-HY)
Loop Antenna	Rohde & Schwarz	HFH2-Z2	100315	9 kHz~30 MHz	Sep. 02, 2015	Jun. 15, 2016 ~ Jun. 18, 2016	Sep. 01, 2016	Radiation (03CH11-HY)
Amplifier	SONOMA	310N	187312	9kHz~1GHz	Nov. 20, 2015	Jun. 15, 2016 ~ Jun. 18, 2016	Nov. 19, 2016	Radiation (03CH11-HY)
Bilog Antenna	TESEQ	CBL 6111D	35414	30MHz~1GHz	Nov. 17, 2015	Jun. 15, 2016 ~ Jun. 18, 2016	Nov. 16, 2016	Radiation (03CH11-HY)
Horn Antenna	SCHWARZBECK	BBHA 9120 D	9120D-1326	1GHz ~ 18GHz	Oct. 08, 2015	Jun. 15, 2016 ~ Jun. 18, 2016	Oct. 07, 2016	Radiation (03CH11-HY)
Preamplifier	Keysight	83017A	MY53270080	1GHz~26.5GHz	Nov. 19, 2015	Jun. 15, 2016 ~ Jun. 18, 2016	Nov. 18, 2016	Radiation (03CH11-HY)
Preamplifier	MITEQ	AMF-7D-0010 1800-30-10P	1902247	1GHz~18GHz	Jul. 01, 2015	Jun. 15, 2016 ~ Jun. 18, 2016	Jun. 30, 2016	Radiation (03CH11-HY)
Spectrum Analyzer	Keysight	N9010A	MY54200486	10Hz ~ 44GHZ	Sep. 24, 2015	Jun. 15, 2016 ~ Jun. 18, 2016	Sep. 23, 2016	Radiation (03CH11-HY)
Antenna Mast	EMEC	AM-BS-4500-B	N/A	1~4m	N/A	Jun. 15, 2016 ~ Jun. 18, 2016	N/A	Radiation (03CH11-HY)
Turn Table	EMEC	TT 2000	N/A	0~360 Degree	N/A	Jun. 15, 2016 ~ Jun. 18, 2016	N/A	Radiation (03CH11-HY)
SHF-EHF Horn Antenna	SCHWARZBECK	BBHA 9170	BBHA917058 4	18GHz- 40GHz	Nov. 02, 2015	Jun. 15, 2016 ~ Jun. 18, 2016	Nov. 01, 2016	Radiation (03CH11-HY)
Preamplifier	MITEQ	TTA0204	1872107	2GHz~40GHz	Feb. 15, 2016	Jun. 15, 2016 ~ Jun. 18, 2016	Feb. 14, 2017	Radiation (03CH11-HY)
AC Power Source	ChainTek	APC-1000W	N/A	N/A	N/A	May 28, 2016	N/A	Conduction (CO05-HY)
EMI Test Receiver	Rohde & Schwarz	ESCI 7	100724	9kHz~7GHz	Aug. 26, 2015	May 28, 2016	Aug. 25, 2016	Conduction (CO05-HY)
LISN	Rohde & Schwarz	ENV216	100080	9kHz~30MHz	Dec. 02, 2015	May 28, 2016	Dec. 01, 2016	Conduction (CO05-HY)



## 5 Uncertainty of Evaluation

### Uncertainty of Conducted Emission Measurement (150kHz ~ 30MHz)

Measuring Uncertainty for a Level of Confidence of 95% ( $U = 2Uc(y)$ )	2.26
---	------

### Uncertainty of Radiated Emission Measurement (30 MHz ~ 1000 MHz)

Measuring Uncertainty for a Level of Confidence of 95% ( $U = 2Uc(y)$ )	4.9
---	-----



## Appendix A. Conducted Test Results

Test Engineer:	Kenny Chen	Temperature:	21~25	°C
Test Date:	2016/5/22	Relative Humidity:	51~54	%

**TEST RESULTS DATA**  
**26dB and 99% OBW**

Band I										
Mod.	Data Rate	NTX	CH.	Freq. (MHz)	99% Bandwidth (MHz)	26 dB Bandwidth (MHz)	IC 99% Bandwidth Power Limit (dBm)	IC 99% Bandwidth EIRP Limit (dBm)		
11a	6Mbps	1	36	5180	19.05	44.10	-	22.80		
11a	6Mbps	1	44	5220	19.10	44.05	-	22.81		
11a	6Mbps	1	48	5240	19.05	43.40	-	22.80		
HT20	MCS0	1	36	5180	18.75	44.20	-	22.73		
HT20	MCS0	1	44	5220	18.40	43.15	-	22.65		
HT20	MCS0	1	48	5240	18.70	42.40	-	22.72		
HT40	MCS0	1	38	5190	36.80	78.75	-	23.01		
HT40	MCS0	1	46	5230	36.60	78.12	-	23.01		

**TEST RESULTS DATA**  
**Average Power Table**

FCC Band I										
Mod.	Data Rate	NTX	CH.	Freq. (MHz)	Duty Factor (dB)	Average Conducted Power (dBm)	FCC Conducted Power Limit (dBm)	DG (dBi)		Pass/Fail
11a	6Mbps	1	36	5180	0.61	15.77	24.00	-1.50		Pass
11a	6Mbps	1	44	5220	0.61	15.49	24.00	-1.50		Pass
11a	6Mbps	1	48	5240	0.61	15.65	24.00	-1.50		Pass
HT20	MCS0	1	36	5180	0.63	14.49	24.00	-1.50		Pass
HT20	MCS0	1	44	5220	0.63	14.03	24.00	-1.50		Pass
HT20	MCS0	1	48	5240	0.63	14.58	24.00	-1.50		Pass
HT40	MCS0	1	38	5190	1.21	13.47	24.00	-1.50		Pass
HT40	MCS0	1	46	5230	1.21	13.87	24.00	-1.50		Pass

**TEST RESULTS DATA**  
**Power Spectral Density**

FCC Band I										
Mod.	Data Rate	NTX	CH.	Freq. (MHz)	Duty Factor (dB)	Average Power Density (dBm/MHz)	Average PSD Limit (dBm/MHz)	DG (dBi)	-	Pass/Fail
11a	6Mbps	1	36	5180	0.61	4.28	11.00	-1.50		Pass
11a	6Mbps	1	44	5220	0.61	3.84	11.00	-1.50		Pass
11a	6Mbps	1	48	5240	0.61	3.89	11.00	-1.50		Pass
HT20	MCS0	1	36	5180	0.63	3.47	11.00	-1.50		Pass
HT20	MCS0	1	44	5220	0.63	2.53	11.00	-1.50		Pass
HT20	MCS0	1	48	5240	0.63	2.86	11.00	-1.50		Pass
HT40	MCS0	1	38	5190	1.21	-0.77	11.00	-1.50		Pass
HT40	MCS0	1	46	5230	1.21	-0.81	11.00	-1.50		Pass

**TEST RESULTS DATA**  
**26dB and 99% OBW**

Band II										
Mod.	Data Rate	NTX	CH.	Freq. (MHz)	99% Bandwidth (MHz)	26 dB Bandwidth (MHz)	IC 99% Bandwidth Power Limit (dBm)	IC 99% Bandwidth EIRP Limit (dBm)	FCC 26dB Bandwidth Power Limit (dBm)	Note
11a	6M bps	1	52	5260	19.15	44.55	23.82	29.82	23.98	
11a	6M bps	1	60	5300	19.55	43.85	23.91	29.91	23.98	
11a	6M bps	1	64	5320	19.30	43.55	23.86	29.86	23.98	
HT20	MCS 0	1	52	5260	18.50	43.25	23.67	29.67	23.98	
HT20	MCS 0	1	60	5300	18.50	43.05	23.67	29.67	23.98	
HT20	MCS 0	1	64	5320	19.15	45.45	23.82	29.82	23.98	
HT40	MCS 0	1	54	5270	36.50	80.46	23.98	30.00	23.98	
HT40	MCS 0	1	62	5310	36.50	68.13	23.98	30.00	23.98	

**TEST RESULTS DATA**  
**Average Power Table**

FCC Band II										
Mod.	Data Rate	NTX	CH.	Freq. (MHz)	Duty Factor (dB)	Average Conducted Power (dBm)	FCC Conducted Power Limit (dBm)	DG (dBi)	EIRP Power Limit (dBm)	Pass/Fail
11a	6M bps	1	52	5260	0.61	16.07	23.98	-1.50	26.99	Pass
11a	6M bps	1	60	5300	0.61	15.69	23.98	-1.50	26.99	Pass
11a	6M bps	1	64	5320	0.61	15.65	23.98	-1.50	26.99	Pass
HT20	MCS 0	1	52	5260	0.63	14.70	23.98	-1.50	26.99	Pass
HT20	MCS 0	1	60	5300	0.63	14.32	23.98	-1.50	26.99	Pass
HT20	MCS 0	1	64	5320	0.63	14.39	23.98	-1.50	26.99	Pass
HT40	MCS 0	1	54	5270	1.21	14.33	23.98	-1.50	26.99	Pass
HT40	MCS 0	1	62	5310	1.21	12.52	23.98	-1.50	26.99	Pass

**TEST RESULTS DATA**  
**Power Spectral Density**

Band II										
Mod.	Data Rate	NTX	CH.	Freq. (MHz)	Duty Factor (dB)	Average Power Density (dBm/MHz)	Average PSD Limit (dBm/MHz)	DG (dBi)		Pass/Fail
11a	6M bps	1	52	5260	0.61	3.84	11.00	-1.50		Pass
11a	6M bps	1	60	5300	0.61	3.49	11.00	-1.50		Pass
11a	6M bps	1	64	5320	0.61	3.56	11.00	-1.50		Pass
HT20	MCS 0	1	52	5260	0.63	2.70	11.00	-1.50		Pass
HT20	MCS 0	1	60	5300	0.63	2.53	11.00	-1.50		Pass
HT20	MCS 0	1	64	5320	0.63	2.40	11.00	-1.50		Pass
HT40	MCS 0	1	54	5270	1.21	-0.68	11.00	-1.50		Pass
HT40	MCS 0	1	62	5310	1.21	-2.27	11.00	-1.50		Pass

**TEST RESULTS DATA**  
**26dB and 99% OBW**

Band III										
Mod.	Data Rate	NTX	CH.	Freq. (MHz)	99% Bandwidth (MHz)	26 dB Bandwidth (MHz)	IC 99% Bandwidth Power Limit (dBm)	IC 99% Bandwidth EIRP Limit (dBm)	FCC 26dB Bandwidth Power Limit (dBm)	Note
11a	6M bps	1	100	5500	19.15	44.45	23.82	29.82	23.98	
11a	6M bps	1	116	5580	19.1	44.45	23.81	29.81	23.98	
11a	6M bps	1	140	5700	19.1	43.85	23.81	29.81	23.98	
HT20	MCS 0	1	100	5500	18.55	41.75	23.68	29.68	23.98	
HT20	MCS 0	1	116	5580	18.7	41.6	23.72	29.72	23.98	
HT20	MCS 0	1	140	5700	19.4	44.95	23.88	29.88	23.98	
HT40	MCS 0	1	102	5510	36.7	79.56	23.98	30.00	23.98	
HT40	MCS 0	1	110	5550	36.7	79.11	23.98	30.00	23.98	
HT40	MCS 0	1	134	5670	37.1	81.27	23.98	30.00	23.98	

**TEST RESULTS DATA**  
**Average Power Table**

FCC Band III										
Mod.	Data Rate	NTX	CH.	Freq. (MHz)	Duty Factor (dB)	Average Conducted Power (dBm)	FCC Conducted Power Limit (dBm)	DG (dBi)	EIRP Power Limit (dBm)	Pass/Fail
11a	6M bps	1	100	5500	0.61	15.72	23.98	-2.30	26.99	Pass
11a	6M bps	1	116	5580	0.61	15.88	23.98	-2.30	26.99	Pass
11a	6M bps	1	140	5700	0.61	15.61	23.98	-2.30	26.99	Pass
HT20	MCS 0	1	100	5500	15.00	14.38	23.98	-2.30	26.99	Pass
HT20	MCS 0	1	116	5580	15.00	14.48	23.98	-2.30	26.99	Pass
HT20	MCS 0	1	140	5700	15.00	14.11	23.98	-2.30	26.99	Pass
HT40	MCS 0	1	102	5510	1.21	14.05	23.98	-2.30	26.99	Pass
HT40	MCS 0	1	110	5550	1.21	14.44	23.98	-2.30	26.99	Pass
HT40	MCS 0	1	134	5670	1.21	14.90	23.98	-2.30	26.99	Pass

**TEST RESULTS DATA**  
**Power Spectral Density**

Band III										
Mod.	Data Rate	NTX	CH.	Freq. (MHz)	Duty Factor (dB)	Average Power Density (dBm/MHz)	Average PSD Limit (dBm/MHz)	DG (dBi)		Pass/Fail
11a	6M bps	1	100	5500	0.61	4.30	11.00	-2.30		Pass
11a	6M bps	1	116	5580	0.61	4.69	11.00	-2.30		Pass
11a	6M bps	1	140	5700	0.61	3.00	11.00	-2.30		Pass
HT20	MCS 0	1	100	5500	0.63	3.18	11.00	-2.30		Pass
HT20	MCS 0	1	116	5580	0.63	3.61	11.00	-2.30		Pass
HT20	MCS 0	1	140	5700	0.63	1.79	11.00	-2.30		Pass
HT40	MCS 0	1	102	5510	1.21	-0.15	11.00	-2.30		Pass
HT40	MCS 0	1	110	5550	1.21	0.17	11.00	-2.30		Pass
HT40	MCS 0	1	134	5670	1.21	-0.11	11.00	-2.30		Pass

**TEST RESULTS DATA**  
**Frequency Stability**

Band I										
Mod.	Data Rate	NTX	CH.	Freq. (MHz)	Center Frequency (MHz)	Frequency Deviation (MHz)	Frequency Stability (ppm)	Temperature (°C)	Voltage (V)	Note
11a	6Mbps	1	36	5180	5179.975	-0.025	-4.83	20	3.4	
11a	6Mbps	1	36	5180	5180.000	0.000	0.00	20	4.35	
11a	6Mbps	1	36	5180	5180.000	0.000	0.00	20	3.9	
11a	6Mbps	1	36	5180	5453.000	273.000	52702.70	-30	3.9	
11a	6Mbps	1	36	5180	5179.975	-0.025	-4.83	50	3.9	

Band II										
Mod.	Data Rate	NTX	CH.	Freq. (MHz)	Center Frequency (MHz)	Frequency Deviation (MHz)	Frequency Stability (ppm)	Temperature (°C)	Voltage (V)	Note
11a	6Mbps	1	64	5320	5319.950	-0.050	-9.40	20	3.4	
11a	6Mbps	1	64	5320	5320.000	0.000	0.00	20	4.35	
11a	6Mbps	1	64	5320	5319.950	-0.050	-9.40	20	3.9	
11a	6Mbps	1	64	5320	5319.950	-0.050	-9.40	-30	3.9	
11a	6Mbps	1	64	5320	5319.950	-0.050	-9.40	50	3.9	

Band III										
Mod.	Data Rate	NTX	CH.	Freq. (MHz)	Center Frequency (MHz)	Frequency Deviation (MHz)	Frequency Stability (ppm)	Temperature (°C)	Voltage (V)	Note
11a	6Mbps	1	100	5500	5500.000	0.000	0.00	20	3.4	
11a	6Mbps	1	100	5500	5500.000	0.000	0.00	20	4.35	
11a	6Mbps	1	100	5500	5499.950	-0.050	-9.09	20	3.9	
11a	6Mbps	1	100	5500	5500.000	0.000	0.00	-30	3.9	
11a	6Mbps	1	100	5500	5500.000	0.000	0.00	50	3.9	



## Appendix B. Radiated Spurious Emission

Test Engineer :	J.C. Liang, Jacky Su, Ken Wu, and Bill Chang	Temperature :	20~23°C
		Relative Humidity :	50~54%

### Band 1 - 5150~5250MHz

#### WIFI 802.11a (Band Edge @ 3m)

WIFI	Note	Frequency	Level	Over	Limit	Read	Antenna	Cable	Preamp	Ant	Table	Peak	Pol.	
Ant.				Limit	Line	Level	Factor	Loss	Factor	Pos	Pos	Avg.		
1		( MHz )	( dBμV/m )	( dB )	( dBμV/m )	( dBμV )	( dB/m )	( dB )	( dB )	( cm )	( deg )	( P/A )	( H/V )	
802.11a CH 36 5180MHz		5381.04	47.97	-26.03	74	38.72	31.86	10.87	33.48	100	119	P	H	
		5469.2	39.53	-14.47	54	30.24	31.96	10.81	33.48	100	119	A	H	
	*	5180	100.22	-	-	91.84	31.62	10.23	33.47	100	119	P	H	
	*	5180	92.63	-	-	84.25	31.62	10.23	33.47	100	119	A	H	
													H	
														H
			5397.84	49.39	-24.61	74	40.12	31.88	10.87	33.48	295	79	P	V
			5426.8	39.53	-14.47	54	30.27	31.9	10.84	33.48	295	79	A	V
	*		5180	105.67	-	-	97.29	31.62	10.23	33.47	295	79	P	V
	*		5180	96.8	-	-	88.42	31.62	10.23	33.47	295	79	A	V
														V
														V
802.11a CH 44 5220MHz		5366.8	48.02	-25.98	74	38.91	31.84	10.75	33.48	100	119	P	H	
		5465.04	39.59	-14.41	54	30.3	31.96	10.81	33.48	100	119	A	H	
	*	5220	100.11	-	-	91.68	31.66	10.24	33.47	100	119	P	H	
	*	5220	92.28	-	-	83.85	31.66	10.24	33.47	100	119	A	H	
			5738.92	47.91	-26.09	74	38.49	32.34	10.65	33.57	100	119	P	H
			5764.36	40.03	-13.97	54	30.62	32.36	10.63	33.58	100	119	A	H
			5464.56	48.92	-25.08	74	39.63	31.96	10.81	33.48	293	76	P	V
			5417.52	39.63	-14.37	54	30.34	31.9	10.87	33.48	293	76	A	V
	*		5220	105.71	-	-	97.28	31.66	10.24	33.47	293	76	P	V
	*		5220	97.17	-	-	88.74	31.66	10.24	33.47	293	76	A	V
			5763.48	49.78	-24.22	74	40.37	32.36	10.63	33.58	293	76	P	V
			5755.4	39.93	-14.07	54	30.51	32.36	10.63	33.57	293	76	A	V



<b>802.11a CH 48 5240MHz</b>		5406.8	48.39	-25.61	74	39.12	31.88	10.87	33.48	100	119	P	H
		5458	39.6	-14.4	54	30.3	31.94	10.84	33.48	100	119	A	H
	*	5240	99.66	-	-	91.08	31.68	10.37	33.47	100	119	P	H
	*	5240	92.07	-	-	83.49	31.68	10.37	33.47	100	119	A	H
		5746.2	48.08	-25.92	74	38.68	32.34	10.63	33.57	100	119	P	H
		5760.52	39.96	-14.04	54	30.55	32.36	10.63	33.58	100	119	A	H
		5423.12	48.33	-25.67	74	39.07	31.9	10.84	33.48	289	77	P	V
		5437.68	39.79	-14.21	54	30.51	31.92	10.84	33.48	289	77	A	V
	*	5240	105.46	-	-	96.88	31.68	10.37	33.47	289	77	P	V
	*	5240	97.38	-	-	88.8	31.68	10.37	33.47	289	77	A	V
		5763.16	48.53	-25.47	74	39.12	32.36	10.63	33.58	289	77	P	V
		5760.04	40.03	-13.97	54	30.62	32.36	10.63	33.58	289	77	A	V
Remark	<p>1. No other spurious found.</p> <p>2. All results are PASS against Peak and Average limit line.</p>												



**Band 1 5150~5250MHz**  
**WIFI 802.11a (Harmonic @ 3m)**

WIFI Ant. 1	Note	Frequency ( MHz )	Level ( dBμV/m )	Over Limit ( dB )	Limit Line ( dBμV/m )	Read Level ( dBμV )	Antenna Factor ( dB/m )	Cable Loss ( dB )	Preamp Factor ( dB )	Ant Pos ( cm )	Table Pos ( deg )	Peak Avg. ( P/A )	Pol. ( H/V )
802.11a CH 36 5180MHz		10360	41.51	-32.49	74	54.36	39.79	14.86	67.5	100	0	P	H
		15540	39.65	-34.35	74	48.55	38.6	17.89	65.39	100	0	P	H
													H
													H
		10360	42.81	-31.19	74	55.66	39.79	14.86	67.5	100	0	P	V
		15540	40.33	-33.67	74	49.23	38.6	17.89	65.39	100	0	P	V
													V
													V
802.11a CH 44 5220MHz		10440	40.14	-33.86	74	52.84	39.89	14.91	67.5	100	0	P	H
		15660	39.4	-34.6	74	48.6	38.23	17.94	65.37	100	0	P	H
													H
													H
		10440	42.25	-31.75	74	54.95	39.89	14.91	67.5	100	0	P	V
		15660	40.35	-33.65	74	49.55	38.23	17.94	65.37	100	0	P	V
													V
													V
802.11a CH 48 5240MHz		10480	40.6	-33.4	74	53.19	39.97	14.94	67.5	100	0	P	H
		15720	38.25	-35.75	74	47.61	38.03	17.97	65.36	100	0	P	H
													H
													H
		10480	41.54	-32.46	74	54.13	39.97	14.94	67.5	100	0	P	V
		15720	41.57	-32.43	74	50.93	38.03	17.97	65.36	100	0	P	V
													V
													V
Remark	1. No other spurious found. 2. All results are PASS against Peak and Average limit line.												



**Band 1 5150~5250MHz**  
**WIFI 802.11n HT20 (Band Edge @ 3m)**

WIFI Ant. 1	Note	Frequency ( MHz )	Level ( dBμV/m )	Over Limit ( dB )	Limit Line ( dBμV/m )	Read Level ( dBμV )	Antenna Factor ( dB/m )	Cable Loss ( dB )	Preamp Factor ( dB )	Ant Pos ( cm )	Table Pos ( deg )	Peak Avg. ( P/A )	Pol. ( H/V )	
802.11n HT20 CH 36 5180MHz		5149.7	50.99	-23.01	74	42.65	31.58	10.23	33.47	103	121	P	H	
		5150	44.71	-9.29	54	36.37	31.58	10.23	33.47	103	121	A	H	
	*	5180	99.84	-	-	91.46	31.62	10.23	33.47	103	121	P	H	
	*	5180	91.42	-	-	83.04	31.62	10.23	33.47	103	121	A	H	
													H	
														H
			5149.4	57.43	-16.57	74	49.09	31.58	10.23	33.47	298	77	P	V
			5149.1	48.08	-5.92	54	39.74	31.58	10.23	33.47	298	77	A	V
		*	5180	104.07	-	-	95.69	31.62	10.23	33.47	298	77	P	V
		*	5180	95.92	-	-	87.54	31.62	10.23	33.47	298	77	A	V
													V	
													V	
802.11n HT20 CH 44 5220MHz		5004.94	48.77	-25.23	74	40.63	31.42	10.19	33.47	107	119	P	H	
		5112.06	39.95	-14.05	54	31.66	31.54	10.22	33.47	107	119	A	H	
		* 5220	99.47	-	-	91.04	31.66	10.24	33.47	107	119	P	H	
		* 5220	91.34	-	-	82.91	31.66	10.24	33.47	107	119	A	H	
			5401.48	48.61	-25.39	74	39.34	31.88	10.87	33.48	107	119	P	H
			5455.44	39.42	-14.58	54	30.12	31.94	10.84	33.48	107	119	A	H
			5087.1	49.69	-24.31	74	41.45	31.5	10.21	33.47	264	81	P	V
			5117.78	40.17	-13.83	54	31.88	31.54	10.22	33.47	264	81	A	V
		*	5220	103.69	-	-	95.26	31.66	10.24	33.47	264	81	P	V
		*	5220	95.56	-	-	87.13	31.66	10.24	33.47	264	81	A	V
		5378.27	48.33	-25.67	74	39.2	31.86	10.75	33.48	264	81	P	V	
		5440.32	39.46	-14.54	54	30.18	31.92	10.84	33.48	264	81	A	V	



<b>802.11n</b>  <b>HT20</b>  <b>CH 48</b>  <b>5240MHz</b>		5010.66	49.06	-24.94	74	40.92	31.42	10.19	33.47	116	118	P	H
		5107.64	40.01	-13.99	54	31.72	31.54	10.22	33.47	116	118	A	H
	*	5240	98.57	-	-	89.99	31.68	10.37	33.47	116	118	P	H
	*	5240	91	-	-	82.42	31.68	10.37	33.47	116	118	A	H
		5439.43	48.45	-25.55	74	39.17	31.92	10.84	33.48	116	118	P	H
		5407.68	39.47	-14.53	54	30.2	31.88	10.87	33.48	116	118	A	H
		5103.48	48.76	-25.24	74	40.49	31.52	10.22	33.47	250	74	P	V
		5050.18	39.98	-14.02	54	31.79	31.46	10.2	33.47	250	74	A	V
	*	5240	103.57	-	-	94.99	31.68	10.37	33.47	250	74	P	V
	*	5240	95.79	-	-	87.21	31.68	10.37	33.47	250	74	A	V
		5406.1	48.96	-25.04	74	39.69	31.88	10.87	33.48	250	74	P	V
		5423.76	39.56	-14.44	54	30.3	31.9	10.84	33.48	250	74	A	V
<b>Remark</b>	1. No other spurious found. 2. All results are PASS against Peak and Average limit line.												



**Band 1 5150~5250MHz**  
**WIFI 802.11n HT20 (Harmonic @ 3m)**

WIFI Ant. 1	Note	Frequency ( MHz )	Level ( dBμV/m )	Over Limit ( dB )	Limit Line ( dBμV/m )	Read Level ( dBμV )	Antenna Factor ( dB/m )	Cable Loss ( dB )	Preamp Factor ( dB )	Ant Pos ( cm )	Table Pos ( deg )	Peak Avg. ( P/A )	Pol. ( H/V )	
802.11n HT20 CH 36 5180MHz		10360	43.55	-30.45	74	56.4	39.79	14.86	67.5	100	0	P	H	
		15540	40.16	-33.84	74	49.06	38.6	17.89	65.39	100	0	P	H	
													H	
													H	
			10360	45.27	-28.73	74	58.12	39.79	14.86	67.5	100	0	P	V
			15540	39.79	-34.21	74	48.69	38.6	17.89	65.39	100	0	P	V
														V
802.11n HT20 CH 44 5220MHz		10440	42.36	-31.64	74	55.06	39.89	14.91	67.5	100	0	P	H	
		15660	38.67	-35.33	74	47.87	38.23	17.94	65.37	100	0	P	H	
													H	
													H	
			10440	43.98	-30.02	74	56.68	39.89	14.91	67.5	100	0	P	V
			15660	39.41	-34.59	74	48.61	38.23	17.94	65.37	100	0	P	V
														V
802.11n HT20 CH 48 5240MHz		10480	42.3	-31.7	74	54.89	39.97	14.94	67.5	100	0	P	H	
		15720	39.68	-34.32	74	49.04	38.03	17.97	65.36	100	0	P	H	
													H	
													H	
			10480	43.14	-30.86	74	55.73	39.97	14.94	67.5	100	0	P	V
			15720	40.53	-33.47	74	49.89	38.03	17.97	65.36	100	0	P	V
														V
Remark	1. No other spurious found.													
	2. All results are PASS against Peak and Average limit line.													



**Band 1 5150~5250MHz**  
**WIFI 802.11n HT40 (Band Edge @ 3m)**

WIFI Ant. 1	Note	Frequency ( MHz )	Level ( dBμV/m )	Over Limit ( dB )	Limit Line ( dBμV/m )	Read Level ( dBμV )	Antenna Factor ( dB/m )	Cable Loss ( dB )	Preamp Factor ( dB )	Ant Pos ( cm )	Table Pos ( deg )	Peak Avg. ( P/A )	Pol. ( H/V )
802.11n HT40 CH 38 5190MHz		5146.64	56.17	-17.83	74	47.83	31.58	10.23	33.47	100	120	P	H
		5149.24	49.03	-4.97	54	40.69	31.58	10.23	33.47	100	120	A	H
	*	5190	94.89	-	-	86.5	31.62	10.24	33.47	100	120	P	H
	*	5190	86.72	-	-	78.33	31.62	10.24	33.47	100	120	A	H
		5368.08	48.04	-25.96	74	38.93	31.84	10.75	33.48	100	120	P	H
		5439.36	40.16	-13.84	54	30.88	31.92	10.84	33.48	100	120	A	H
		5146.9	59.29	-14.71	74	50.95	31.58	10.23	33.47	297	60	P	V
		5150.02	52.61	-1.39	54	44.27	31.58	10.23	33.47	297	60	A	V
	*	5190	99.29	-	-	90.9	31.62	10.24	33.47	297	60	P	V
	*	5190	91.09	-	-	82.7	31.62	10.24	33.47	297	60	A	V
		5353.2	46.9	-27.1	74	37.81	31.82	10.75	33.48	297	60	P	V
		5452.8	40.03	-13.97	54	30.73	31.94	10.84	33.48	297	60	A	V
	802.11n HT40 CH 46 5230MHz		5041.6	47.92	-26.08	74	39.73	31.46	10.2	33.47	100	118	P
		5147.42	41.05	-12.95	54	32.71	31.58	10.23	33.47	100	118	A	H
*		5230	95.86	-	-	87.28	31.68	10.37	33.47	100	118	P	H
*		5230	88.27	-	-	79.69	31.68	10.37	33.47	100	118	A	H
		5389.2	47.79	-26.21	74	38.54	31.86	10.87	33.48	100	118	P	H
		5430	40.19	-13.81	54	30.91	31.92	10.84	33.48	100	118	A	H
		5146.38	49.83	-24.17	74	41.49	31.58	10.23	33.47	296	74	P	V
		5149.5	42.47	-11.53	54	34.13	31.58	10.23	33.47	296	74	A	V
*		5230	101.97	-	-	93.39	31.68	10.37	33.47	296	74	P	V
*		5230	93.53	-	-	84.95	31.68	10.37	33.47	296	74	A	V
	5393.52	49	-25	74	39.75	31.86	10.87	33.48	296	74	P	V	
	5454.96	40.18	-13.82	54	30.88	31.94	10.84	33.48	296	74	A	V	
Remark	1. No other spurious found. 2. All results are PASS against Peak and Average limit line.												



**Band 1 5150~5250MHz**  
**WIFI 802.11n HT40 (Harmonic @ 3m)**

WIFI Ant. 1	Note	Frequency ( MHz )	Level ( dBµV/m )	Over Limit ( dB )	Limit Line ( dBµV/m )	Read Level (dBµV)	Antenna Factor ( dB/m )	Cable Loss ( dB )	Preamp Factor ( dB )	Ant Pos ( cm )	Table Pos ( deg )	Peak Avg. (P/A)	Pol. (H/V)
802.11n HT40 CH 38 5190MHz		10380	42.57	-31.43	74	55.4	39.81	14.86	67.5	100	0	P	H
		15570	40.26	-33.74	74	49.26	38.49	17.9	65.39	100	0	P	H
													H
													H
		10380	43.73	-30.27	74	56.56	39.81	14.86	67.5	100	0	P	V
		15570	39.63	-34.37	74	48.63	38.49	17.9	65.39	100	0	P	V
													V
802.11n HT40 CH 46 5230MHz		10460	42.19	-31.81	74	54.86	39.92	14.91	67.5	100	0	P	H
		15690	39.52	-34.48	74	48.79	38.13	17.96	65.36	100	0	P	H
													H
													H
		10460	43.37	-30.63	74	56.04	39.92	14.91	67.5	100	0	P	V
		15690	39.76	-34.24	74	49.03	38.13	17.96	65.36	100	0	P	V
													V
Remark	1. No other spurious found.												
	2. All results are PASS against Peak and Average limit line.												



**Band 2 - 5250~5350MHz**  
**WIFI 802.11a (Band Edge @ 3m)**

WIFI	Note	Frequency	Level	Over	Limit	Read	Antenna	Cable	Preamp	Ant	Table	Peak	Pol.
Ant.				Limit	Line	Level	Factor	Loss	Factor	Pos	Pos	Avg.	
1		( MHz )	( dBμV/m )	( dB )	( dBμV/m )	( dBμV )	( dB/m )	( dB )	( dB )	( cm )	( deg )	(P/A)	(H/V)
802.11a CH 52 5260MHz		5410.64	50	-24	74	40.73	31.88	10.87	33.48	100	119	P	H
		5452.56	39.58	-14.42	54	30.28	31.94	10.84	33.48	100	119	A	H
	*	5260	100.87	-	-	92.26	31.72	10.37	33.48	100	119	P	H
	*	5260	92.64	-	-	84.03	31.72	10.37	33.48	100	119	A	H
		5759.32	48.95	-25.05	74	39.54	32.36	10.63	33.58	100	119	P	H
		5763.32	39.97	-14.03	54	30.56	32.36	10.63	33.58	100	119	A	H
		5468.4	48.5	-25.5	74	39.21	31.96	10.81	33.48	309	74	P	V
		5463.6	39.58	-14.42	54	30.29	31.96	10.81	33.48	309	74	A	V
	*	5260	105.29	-	-	96.68	31.72	10.37	33.48	309	74	P	V
	*	5260	97.42	-	-	88.81	31.72	10.37	33.48	309	74	A	V
		5746.6	48.96	-25.04	74	39.56	32.34	10.63	33.57	309	74	P	V
		5749.64	39.99	-14.01	54	30.59	32.34	10.63	33.57	309	74	A	V
802.11a CH 60 5300MHz		5350	49.46	-24.54	74	40.37	31.82	10.75	33.48	100	118	P	H
		5352.24	40.92	-13.08	54	31.83	31.82	10.75	33.48	100	118	A	H
	*	5300	100.66	-	-	91.89	31.76	10.49	33.48	100	118	P	H
	*	5300	93.1	-	-	84.33	31.76	10.49	33.48	100	118	A	H
		5754.84	49.07	-24.93	74	39.65	32.36	10.63	33.57	100	118	P	H
		5764.6	39.98	-14.02	54	30.57	32.36	10.63	33.58	100	118	A	H
		5351.28	53.26	-20.74	74	44.17	31.82	10.75	33.48	308	74	P	V
		5352.24	45.24	-8.76	54	36.15	31.82	10.75	33.48	308	74	A	V
	*	5300	105.88	-	-	97.11	31.76	10.49	33.48	308	74	P	V
	*	5300	98.08	-	-	89.31	31.76	10.49	33.48	308	74	A	V
		5735.56	48.47	-25.53	74	39.05	32.34	10.65	33.57	308	74	P	V
		5752.76	39.94	-14.06	54	30.52	32.36	10.63	33.57	308	74	A	V



<b>802.11a</b> <b>CH 64</b> <b>5320MHz</b>		5351.76	56.62	-17.38	74	47.53	31.82	10.75	33.48	247	86	P	H
		5350	48.3	-5.7	54	39.21	31.82	10.75	33.48	247	86	A	H
	*	5320	100.19	-	-	91.27	31.78	10.62	33.48	247	86	P	H
	*	5320	92.07	-	-	83.15	31.78	10.62	33.48	247	86	A	H
		5747.96	48.27	-25.73	74	38.87	32.34	10.63	33.57	247	86	P	H
		5763.64	39.99	-14.01	54	30.58	32.36	10.63	33.58	247	86	A	H
		5352.24	62.94	-11.06	74	53.85	31.82	10.75	33.48	290	71	P	V
		5350	52.57	-1.43	54	43.48	31.82	10.75	33.48	290	71	A	V
	*	5320	105.12	-	-	96.2	31.78	10.62	33.48	290	71	P	V
	*	5320	97.24	-	-	88.32	31.78	10.62	33.48	290	71	A	V
		5747.4	47.53	-26.47	74	38.13	32.34	10.63	33.57	290	71	P	V
		5741.24	40.01	-13.99	54	30.61	32.34	10.63	33.57	290	71	A	V
<b>Remark</b>	1. No other spurious found. 2. All results are PASS against Peak and Average limit line.												



**Band 2 5250~5350MHz**  
**WIFI 802.11a (Harmonic @ 3m)**

WIFI Ant. 1	Note	Frequency ( MHz )	Level ( dBμV/m )	Over Limit ( dB )	Limit Line ( dBμV/m )	Read Level ( dBμV )	Antenna Factor ( dB/m )	Cable Loss ( dB )	Preamp Factor ( dB )	Ant Pos ( cm )	Table Pos ( deg )	Peak Avg. ( P/A )	Pol. ( H/V )
802.11a CH 52 5260MHz		10520	40.92	-33.08	74	53.43	40.01	14.96	67.48	100	0	P	H
		15780	37.95	-36.05	74	47.43	37.87	17.99	65.34	100	0	P	H
													H
													H
		10520	41.99	-32.01	74	54.5	40.01	14.96	67.48	100	0	P	V
		15780	40.03	-33.97	74	49.51	37.87	17.99	65.34	100	0	P	V
													V
													V
802.11a CH 60 5300MHz		10600	40.36	-33.64	74	52.68	40.06	15.02	67.4	100	0	P	H
		15900	39.07	-34.93	74	48.84	37.51	18.04	65.32	100	0	P	H
													H
													H
		10600	42.51	-31.49	74	54.83	40.06	15.02	67.4	100	0	P	V
		15900	42.16	-31.84	74	51.93	37.51	18.04	65.32	100	0	P	V
													V
													V
802.11a CH 64 5320MHz		10640	40.76	-33.24	74	53	40.08	15.04	67.36	100	0	P	H
		15960	39.46	-34.54	74	49.39	37.3	18.08	65.31	100	0	P	H
													H
													H
		10640	42.37	-31.63	74	54.61	40.08	15.04	67.36	100	0	P	V
		15960	40.98	-33.02	74	50.91	37.3	18.08	65.31	100	0	P	V
													V
													V
Remark	1. No other spurious found. 2. All results are PASS against Peak and Average limit line.												



**Band 2 5250~5350MHz**  
**WIFI 802.11n HT20 (Band Edge @ 3m)**

WIFI Ant. 1	Note	Frequency ( MHz )	Level ( dBμV/m )	Over Limit ( dB )	Limit Line ( dBμV/m )	Read Level ( dBμV )	Antenna Factor ( dB/m )	Cable Loss ( dB )	Preamp Factor ( dB )	Ant Pos ( cm )	Table Pos ( deg )	Peak Avg. ( P/A )	Pol. ( H/V )
802.11n HT20 CH 52 5260MHz		5142.48	48.24	-25.76	74	39.9	31.58	10.23	33.47	100	118	P	H
		5111.8	40.08	-13.92	54	31.79	31.54	10.22	33.47	100	118	A	H
	*	5260	99.16	-	-	90.55	31.72	10.37	33.48	100	118	P	H
	*	5260	91.64	-	-	83.03	31.72	10.37	33.48	100	118	A	H
		5387.07	48.79	-25.21	74	39.54	31.86	10.87	33.48	100	118	P	H
		5457.36	39.41	-14.59	54	30.11	31.94	10.84	33.48	100	118	A	H
		5006.24	48.79	-25.21	74	40.65	31.42	10.19	33.47	300	71	P	V
		5092.56	40.13	-13.87	54	31.87	31.52	10.21	33.47	300	71	A	V
	*	5260	104.11	-	-	95.5	31.72	10.37	33.48	300	71	P	V
	*	5260	96.39	-	-	87.78	31.72	10.37	33.48	300	71	A	V
		5439.98	48.74	-25.26	74	39.46	31.92	10.84	33.48	300	71	P	V
		5457.12	39.6	-14.4	54	30.3	31.94	10.84	33.48	300	71	A	V
802.11n HT20 CH 60 5300MHz		5135.98	48.41	-25.59	74	40.1	31.56	10.22	33.47	101	118	P	H
		5068.64	40.04	-13.96	54	31.82	31.48	10.21	33.47	101	118	A	H
	*	5300	99.83	-	-	91.06	31.76	10.49	33.48	101	118	P	H
	*	5300	91.79	-	-	83.02	31.76	10.49	33.48	101	118	A	H
		5352.75	48.95	-25.05	74	39.86	31.82	10.75	33.48	101	118	P	H
		5351.76	40.63	-13.37	54	31.54	31.82	10.75	33.48	101	118	A	H
		5126.88	48.38	-25.62	74	40.07	31.56	10.22	33.47	272	75	P	V
		5089.18	40.22	-13.78	54	31.96	31.52	10.21	33.47	272	75	A	V
	*	5300	104.31	-	-	95.54	31.76	10.49	33.48	272	75	P	V
	*	5300	96.25	-	-	87.48	31.76	10.49	33.48	272	75	A	V
	5350.55	51.48	-22.52	74	42.39	31.82	10.75	33.48	272	75	P	V	
	5352	44.29	-9.71	54	35.2	31.82	10.75	33.48	272	75	A	V	



<b>802.11n</b>  <b>HT20</b>  <b>CH 64</b>  <b>5320MHz</b>		5047.06	49.44	-24.56	74	41.25	31.46	10.2	33.47	103	118	P	H
		5089.18	40.03	-13.97	54	31.77	31.52	10.21	33.47	103	118	A	H
	*	5320	98.23	-	-	89.31	31.78	10.62	33.48	103	118	P	H
	*	5320	90.8	-	-	81.88	31.78	10.62	33.48	103	118	A	H
		5351.21	54.3	-19.7	74	45.21	31.82	10.75	33.48	103	118	P	H
		5350.32	43.94	-10.06	54	34.85	31.82	10.75	33.48	103	118	A	H
		5097.24	48.2	-25.8	74	39.94	31.52	10.21	33.47	306	73	P	V
		5085.8	40.18	-13.82	54	31.94	31.5	10.21	33.47	306	73	A	V
	*	5320	104.11	-	-	95.19	31.78	10.62	33.48	306	73	P	V
	*	5320	96.75	-	-	87.83	31.78	10.62	33.48	306	73	A	V
		5350.22	58.21	-15.79	74	49.12	31.82	10.75	33.48	306	73	P	V
		5350.08	50.6	-3.4	54	41.51	31.82	10.75	33.48	306	73	A	V
<b>Remark</b>	1. No other spurious found. 2. All results are PASS against Peak and Average limit line.												



**Band 2 5250~5350MHz**  
**WIFI 802.11n HT20 (Harmonic @ 3m)**

WIFI Ant. 1	Note	Frequency ( MHz )	Level ( dBμV/m )	Over Limit ( dB )	Limit Line ( dBμV/m )	Read Level ( dBμV )	Antenna Factor ( dB/m )	Cable Loss ( dB )	Preamp Factor ( dB )	Ant Pos ( cm )	Table Pos ( deg )	Peak Avg. ( P/A )	Pol. ( H/V )	
802.11n HT20 CH 52 5260MHz		10520	43.1	-30.9	74	55.61	40.01	14.96	67.48	100	0	P	H	
		15780	39.43	-34.57	74	48.91	37.87	17.99	65.34	100	0	P	H	
													H	
													H	
			10520	44.98	-29.02	74	57.49	40.01	14.96	67.48	100	0	P	V
			15780	39.8	-34.2	74	49.28	37.87	17.99	65.34	100	0	P	V
														V
802.11n HT20 CH 60 5300MHz		10600	42.88	-31.12	74	55.2	40.06	15.02	67.4	100	0	P	H	
		15900	38.35	-35.65	74	48.12	37.51	18.04	65.32	100	0	P	H	
													H	
													H	
			10600	43.74	-30.26	74	56.06	40.06	15.02	67.4	100	0	P	V
			15900	41.72	-32.28	74	51.49	37.51	18.04	65.32	100	0	P	V
														V
802.11n HT20 CH 64 5320MHz		10640	42.25	-31.75	74	54.49	40.08	15.04	67.36	100	0	P	H	
		15960	37.78	-36.22	74	47.71	37.3	18.08	65.31	100	0	P	H	
													H	
													H	
			10640	42.62	-31.38	74	54.86	40.08	15.04	67.36	100	0	P	V
			15960	41.63	-32.37	74	51.56	37.3	18.08	65.31	100	0	P	V
														V
Remark	1. No other spurious found.													
	2. All results are PASS against Peak and Average limit line.													



**Band 2 5250~5350MHz  
WIFI 802.11n HT40 (Band Edge @ 3m)**

WIFI Ant. 1	Note	Frequency ( MHz )	Level ( dBμV/m )	Over Limit ( dB )	Limit Line ( dBμV/m )	Read Level ( dBμV )	Antenna Factor ( dB/m )	Cable Loss ( dB )	Preamp Factor ( dB )	Ant Pos ( cm )	Table Pos ( deg )	Peak Avg. ( P/A )	Pol. ( H/V )
802.11n HT40 CH 54 5270MHz		5069.16	48.55	-25.45	74	40.33	31.48	10.21	33.47	100	117	P	H
		5102.7	40.72	-13.28	54	32.45	31.52	10.22	33.47	100	117	A	H
	*	5270	95.96	-	-	87.23	31.72	10.49	33.48	100	117	P	H
	*	5270	87.34	-	-	78.61	31.72	10.49	33.48	100	117	A	H
		5421.12	48.86	-25.14	74	39.6	31.9	10.84	33.48	100	117	P	H
		5350.08	40.22	-13.78	54	31.13	31.82	10.75	33.48	100	117	A	H
		5040.04	49.13	-24.87	74	40.94	31.46	10.2	33.47	296	74	P	V
		5068.64	40.87	-13.13	54	32.65	31.48	10.21	33.47	296	74	A	V
	*	5270	102.18	-	-	93.45	31.72	10.49	33.48	296	74	P	V
	*	5270	93.77	-	-	85.04	31.72	10.49	33.48	296	74	A	V
		5350.56	49.77	-24.23	74	40.68	31.82	10.75	33.48	296	74	P	V
		5350.08	42.54	-11.46	54	33.45	31.82	10.75	33.48	296	74	A	V
802.11n HT40 CH 62 5310MHz		5029.38	48.67	-25.33	74	40.5	31.44	10.2	33.47	100	117	P	H
		5025.22	40.91	-13.09	54	32.74	31.44	10.2	33.47	100	117	A	H
	*	5310	95.26	-	-	86.34	31.78	10.62	33.48	100	117	P	H
	*	5310	85.61	-	-	76.69	31.78	10.62	33.48	100	117	A	H
		5350.8	51.92	-22.08	74	42.83	31.82	10.75	33.48	100	117	P	H
		5351.04	47.92	-6.08	54	38.83	31.82	10.75	33.48	100	117	A	H
		5015.34	49.77	-24.23	74	41.63	31.42	10.19	33.47	304	70	P	V
		5046.28	40.83	-13.17	54	32.64	31.46	10.2	33.47	304	70	A	V
	*	5310	100.43	-	-	91.51	31.78	10.62	33.48	304	70	P	V
	*	5310	91.74	-	-	82.82	31.78	10.62	33.48	304	70	A	V
	5351.52	63.61	-10.39	74	54.52	31.82	10.75	33.48	304	70	P	V	
	5350.56	53.1	-0.9	54	44.01	31.82	10.75	33.48	304	70	A	V	
Remark	1. No other spurious found. 2. All results are PASS against Peak and Average limit line.												



**Band 2 5250~5350MHz**  
**WIFI 802.11n HT40 (Harmonic @ 3m)**

WIFI Ant. 1	Note	Frequency ( MHz )	Level ( dBμV/m )	Over Limit ( dB )	Limit Line ( dBμV/m )	Read Level ( dBμV )	Antenna Factor ( dB/m )	Cable Loss ( dB )	Preamp Factor ( dB )	Ant Pos ( cm )	Table Pos ( deg )	Peak Avg. ( P/A )	Pol. ( H/V )
802.11n HT40 CH 54 5270MHz		10540	41.03	-32.97	74	53.52	40.02	14.96	67.47	100	0	P	H
		15810	38.15	-35.85	74	47.71	37.77	18.01	65.34	100	0	P	H
													H
													H
		10540	42.62	-31.38	74	55.11	40.02	14.96	67.47	100	0	P	V
		15810	38.38	-35.62	74	47.94	37.77	18.01	65.34	100	0	P	V
													V
													V
802.11n HT40 CH 62 5310MHz		10620	40.64	-33.36	74	52.93	40.07	15.02	67.38	100	0	P	H
		15930	37.3	-36.7	74	47.14	37.41	18.06	65.31	100	0	P	H
													H
													H
		10620	42.42	-31.58	74	54.71	40.07	15.02	67.38	100	0	P	V
		15930	37.92	-36.08	74	47.76	37.41	18.06	65.31	100	0	P	V
													V
													V
Remark	1. No other spurious found. 2. All results are PASS against Peak and Average limit line.												



**Band 3 - 5470~5725MHz**  
**WIFI 802.11a (Band Edge @ 3m)**

WIFI	Note	Frequency	Level	Over	Limit	Read	Antenna	Cable	Preamp	Ant	Table	Peak	Pol.	
Ant.				Limit	Line	Level	Factor	Loss	Factor	Pos	Pos	Avg.		
1		( MHz )	( dBμV/m )	( dB )	( dBμV/m )	( dBμV )	( dB/m )	( dB )	( dB )	( cm )	( deg )	(P/A)	(H/V)	
802.11a CH 100 5500MHz		5456.08	52.94	-21.06	74	43.64	31.94	10.84	33.48	303	90	P	H	
		5468.56	58.03	-10.27	68.3	48.74	31.96	10.81	33.48	303	90	P	H	
		5458.48	43.45	-10.55	54	34.15	31.94	10.84	33.48	303	90	A	H	
	*	5500	100.73	-	-	91.4	32	10.81	33.48	303	90	P	H	
		5500	89.93	-	-	80.6	32	10.81	33.48	303	90	A	H	
														H
			5459	55.95	-18.05	74	46.65	31.94	10.84	33.48	300	69	P	V
			5469.2	67.53	-0.77	68.3	58.24	31.96	10.81	33.48	300	69	P	V
			5459.12	48.36	-5.64	54	39.06	31.94	10.84	33.48	300	69	A	V
	*		5501	105.81	-	-	96.53	32	10.77	33.49	300	69	P	V
			5501	95.79	-	-	86.51	32	10.77	33.49	300	69	A	V
														V
802.11a CH 116 5580MHz		5451.92	48.27	-25.73	74	38.97	31.94	10.84	33.48	288	117	P	H	
		5467.92	39.44	-14.56	54	30.15	31.96	10.81	33.48	288	117	A	H	
	*	5580	100.61	-	-	91.29	32.1	10.74	33.52	288	117	P	H	
	*	5580	91.97	-	-	82.65	32.1	10.74	33.52	288	117	A	H	
			5732.2	48.42	-25.58	74	39.03	32.31	10.65	33.57	288	117	P	H
			5740.36	39.94	-14.06	54	30.54	32.34	10.63	33.57	288	117	A	H
			5439.28	48.47	-25.53	74	39.19	31.92	10.84	33.48	339	50	P	V
			5464.56	39.49	-14.51	54	30.2	31.96	10.81	33.48	339	50	A	V
	*		5580	105.78	-	-	96.46	32.1	10.74	33.52	339	50	P	V
	*		5580	98.04	-	-	88.72	32.1	10.74	33.52	339	50	A	V
			5759.08	48.16	-25.84	74	38.75	32.36	10.63	33.58	339	50	P	V
			5764.6	39.97	-14.03	54	30.56	32.36	10.63	33.58	339	50	A	V



<b>802.11a</b> <b>CH 140</b> <b>5700MHz</b>	*	5700	99.46	-	-	90.08	32.27	10.67	33.56	394	145	P	H
		5700	91.19	-	-	81.81	32.27	10.67	33.56	394	145	A	H
		5725.96	56.24	-12.06	68.3	46.85	32.31	10.65	33.57	394	145	P	H
													H
													H
													H
	*	5700	105.08	-	-	95.7	32.27	10.67	33.56	362	51	P	V
		5700	97.55	-	-	88.17	32.27	10.67	33.56	362	51	A	V
		5725.24	64.91	-3.39	68.3	55.52	32.31	10.65	33.57	362	51	P	V
													V
													V
													V
<b>Remark</b>	1. No other spurious found. 2. All results are PASS against Peak and Average limit line.												



**Band 3 - 5470~5725MHz**  
**WIFI 802.11a (Harmonic @ 3m)**

WIFI Ant. 1	Note	Frequency ( MHz )	Level ( dBμV/m )	Over Limit ( dB )	Limit Line ( dBμV/m )	Read Level (dBμV)	Antenna Factor ( dB/m )	Cable Loss ( dB )	Preamp Factor ( dB )	Ant Pos ( cm )	Table Pos ( deg )	Peak Avg. (P/A)	Pol. (H/V)
802.11a CH 100 5500MHz		11000	42.54	-31.46	74	53.97	40.3	15.27	67	100	0	P	H
		16500	39.74	-28.56	68.3	46.55	38.9	18.29	64	100	0	P	H
													H
													H
		11000	43.76	-30.24	74	55.19	40.3	15.27	67	100	0	P	V
		16500	39.69	-28.61	68.3	46.5	38.9	18.29	64	100	0	P	V
													V
													V
802.11a CH 116 5580MHz		11160	42.11	-31.89	74	53.13	40.17	15.38	66.57	100	0	P	H
		16740	39.15	-34.85	74	45.08	39.58	18.39	63.9	100	0	P	H
													H
													H
		11160	43.06	-30.94	74	54.08	40.17	15.38	66.57	100	0	P	V
		16740	37.74	-36.26	74	43.67	39.58	18.39	63.9	100	0	P	V
													V
													V
802.11a CH 140 5700MHz		11400	42.28	-31.72	74	52.73	39.98	15.53	65.96	100	0	P	H
		17100	41.48	-26.82	68.3	46.27	40.6	18.53	63.92	100	0	P	H
													H
													H
		11400	42.98	-31.02	74	53.43	39.98	15.53	65.96	100	0	P	V
		17100	42.27	-26.03	68.3	47.06	40.6	18.53	63.92	100	0	P	V
													V
													V
Remark	1. No other spurious found. 2. All results are PASS against Peak and Average limit line.												



**Band 3 - 5470~5725MHz**  
**WIFI 802.11n HT20 (Band Edge @ 3m)**

WIFI Ant. 1	Note	Frequency ( MHz )	Level ( dBμV/m )	Over Limit ( dB )	Limit Line ( dBμV/m )	Read Level ( dBμV )	Antenna Factor ( dB/m )	Cable Loss ( dB )	Preamp Factor ( dB )	Ant Pos ( cm )	Table Pos ( deg )	Peak Avg. ( P/A )	Pol. ( H/V )	
802.11n HT20 CH 100 5500MHz		5468.08	58.53	-15.47	74	49.24	31.96	10.81	33.48	337	80	P	H	
		5469.68	48.26	-5.74	54	38.97	31.96	10.81	33.48	337	80	A	H	
	*	5500	100.28	-	-	90.95	32	10.81	33.48	337	80	P	H	
	*	5500	91.65	-	-	82.32	32	10.81	33.48	337	80	A	H	
													H	
														H
			5468.72	64.93	-9.07	74	55.64	31.96	10.81	33.48	300	69	P	V
			5470	52.55	-1.45	54	43.26	31.96	10.81	33.48	300	69	A	V
		*	5500	104.72	-	-	95.39	32	10.81	33.48	300	69	P	V
		*	5500	96.04	-	-	86.71	32	10.81	33.48	300	69	A	V
													V	
													V	
802.11n HT20 CH 116 5580MHz		5454.32	48.63	-25.37	74	39.33	31.94	10.84	33.48	392	349	P	H	
		5452.72	39.69	-14.31	54	30.39	31.94	10.84	33.48	392	349	A	H	
		* 5580	98.77	-	-	89.45	32.1	10.74	33.52	392	349	P	H	
		* 5580	90.03	-	-	80.71	32.1	10.74	33.52	392	349	A	H	
			5741.16	47.84	-26.16	74	38.44	32.34	10.63	33.57	392	349	P	H
			5764.36	40.04	-13.96	54	30.63	32.36	10.63	33.58	392	349	A	H
			5389.52	48.25	-25.75	74	39	31.86	10.87	33.48	290	56	P	V
			5448.4	39.69	-14.31	54	30.39	31.94	10.84	33.48	290	56	A	V
		*	5580	104.27	-	-	94.95	32.1	10.74	33.52	290	56	P	V
		*	5580	95.97	-	-	86.65	32.1	10.74	33.52	290	56	A	V
		5756.12	48.65	-25.35	74	39.24	32.36	10.63	33.58	290	56	P	V	
		5758.04	40.07	-13.93	54	30.66	32.36	10.63	33.58	290	56	A	V	



<b>802.11n</b>  <b>HT20</b>  <b>CH 140</b>  <b>5700MHz</b>	*	5700	98.12	-	-	88.74	32.27	10.67	33.56	260	114	P	H
		5700	88.73	-	-	79.35	32.27	10.67	33.56	260	114	A	H
		5725.08	56.37	-11.93	68.3	46.98	32.31	10.65	33.57	260	114	P	H
													H
													H
													H
	*	5700	104.78	-	-	95.4	32.27	10.67	33.56	293	51	P	V
		5700	95.78	-	-	86.4	32.27	10.67	33.56	293	51	A	V
		5725.24	63.8	-4.5	68.3	54.41	32.31	10.65	33.57	293	51	P	V
													V
												V	
												V	
<b>Remark</b>	1. No other spurious found. 2. All results are PASS against Peak and Average limit line.												



**Band 3 - 5470~5725MHz**  
**WIFI 802.11n HT20 (Harmonic @ 3m)**

WIFI Ant. 1	Note	Frequency ( MHz )	Level ( dBμV/m )	Over Limit ( dB )	Limit Line ( dBμV/m )	Read Level ( dBμV )	Antenna Factor ( dB/m )	Cable Loss ( dB )	Preamp Factor ( dB )	Ant Pos ( cm )	Table Pos ( deg )	Peak Avg. ( P/A )	Pol. ( H/V )
802.11n HT20 CH 100 5500MHz		11000	41.93	-32.07	74	53.36	40.3	15.27	67	100	0	P	H
		16500	38.21	-35.79	74	45.02	38.9	18.29	64	100	0	P	H
													H
													H
		11000	43.29	-30.71	74	54.72	40.3	15.27	67	100	0	P	V
		16500	39.8	-34.2	74	46.61	38.9	18.29	64	100	0	P	V
802.11n HT20 CH 116 5580MHz		11600	41.9	-32.1	74	52.19	39.69	15.66	65.64	100	0	P	H
		16740	38.2	-35.8	74	44.13	39.58	18.39	63.9	100	0	P	H
													H
													H
		11160	42.18	-31.82	74	53.2	40.17	15.38	66.57	100	0	P	V
		16740	38.21	-35.79	74	44.14	39.58	18.39	63.9	100	0	P	V
802.11n HT20 CH 140 5700MHz		11400	42.04	-31.96	74	52.49	39.98	15.53	65.96	100	0	P	H
		17100	40.6	-27.7	68.3	45.39	40.6	18.53	63.92	100	0	P	H
													H
													H
		11400	42.46	-31.54	74	52.91	39.98	15.53	65.96	100	0	P	V
		17100	41.93	-26.37	68.3	46.72	40.6	18.53	63.92	100	0	P	V
Remark	1. No other spurious found.												
	2. All results are PASS against Peak and Average limit line.												



**Band 3 - 5470~5725MHz**  
**WIFI 802.11n HT40 (Band Edge @ 3m)**

WIFI Ant. 1	Note	Frequency ( MHz )	Level ( dBμV/m )	Over Limit ( dB )	Limit Line ( dBμV/m )	Read Level ( dBμV )	Antenna Factor ( dB/m )	Cable Loss ( dB )	Preamp Factor ( dB )	Ant Pos ( cm )	Table Pos ( deg )	Peak Avg. ( P/A )	Pol. ( H/V )
802.11n HT40 CH 102 5510MHz		5452.4	54.12	-19.88	74	44.82	31.94	10.84	33.48	300	117	P	H
		5468.08	65.93	-2.37	68.3	56.64	31.96	10.81	33.48	300	117	P	H
		5459.67	47.85	-6.15	54	38.55	31.94	10.84	33.48	300	117	A	H
	*	5510	95.73	-	-	86.45	32	10.77	33.49	300	117	P	H
		5510	87.49	-	-	78.21	32	10.77	33.49	300	117	A	H
		5744.36	48.05	-20.25	68.3	38.65	32.34	10.63	33.57	300	117	P	H
		5458.96	61.91	-12.09	74	52.61	31.94	10.84	33.48	389	60	P	V
		5467.44	67.14	-1.16	68.3	57.85	31.96	10.81	33.48	389	60	P	V
		5460	51.87	-2.13	54	42.57	31.94	10.84	33.48	389	60	A	V
	*	5510	101.81	-	-	92.53	32	10.77	33.49	389	60	P	V
		5510	92.65	-	-	83.37	32	10.77	33.49	389	60	A	V
		5755.48	48.92	-19.38	68.3	39.5	32.36	10.63	33.57	389	60	P	V
802.11n HT40 CH 110 5550MHz		5466.16	48.9	-25.1	74	39.61	31.96	10.81	33.48	314	89	P	H
		5467.44	41.35	-12.65	54	32.06	31.96	10.81	33.48	314	89	A	H
	*	5550	96.8	-	-	87.49	32.07	10.74	33.5	314	89	P	H
	*	5550	88.28	-	-	78.97	32.07	10.74	33.5	314	89	A	H
		5753.96	48.56	-25.44	74	39.14	32.36	10.63	33.57	314	89	P	H
		5744.6	40.76	-13.24	54	31.36	32.34	10.63	33.57	314	89	A	H
		5454.16	50.45	-23.55	74	41.15	31.94	10.84	33.48	299	72	P	V
		5470	42.94	-11.06	54	33.65	31.96	10.81	33.48	299	72	A	V
	*	5550	101.12	-	-	91.81	32.07	10.74	33.5	299	72	P	V
	*	5550	92.84	-	-	83.53	32.07	10.74	33.5	299	72	A	V
	5742.44	48.14	-25.86	74	38.74	32.34	10.63	33.57	299	72	P	V	
	5750.28	40.87	-13.13	54	31.47	32.34	10.63	33.57	299	72	A	V	



<b>802.11n</b>  <b>HT40</b>  <b>CH 134</b>  <b>5670MHz</b>		5448.24	48.09	-25.91	74	38.79	31.94	10.84	33.48	300	88	P	H
		5467.76	40.23	-13.77	54	30.94	31.96	10.81	33.48	300	88	A	H
	*	5670	95.58	-	-	86.22	32.24	10.67	33.55	300	88	P	H
	*	5670	87.37	-	-	78.01	32.24	10.67	33.55	300	88	A	H
		5725.72	50.1	-23.9	74	40.71	32.31	10.65	33.57	300	88	P	H
		5727.24	42.38	-11.62	54	32.99	32.31	10.65	33.57	300	88	A	H
		5432.72	47.73	-26.27	74	38.45	31.92	10.84	33.48	383	49	P	V
		5470	40.38	-13.62	54	31.09	31.96	10.81	33.48	383	49	A	V
	*	5670	101.67	-	-	92.31	32.24	10.67	33.55	383	49	P	V
	*	5670	93.67	-	-	84.31	32.24	10.67	33.55	383	49	A	V
		5725.4	55.49	-18.51	74	46.1	32.31	10.65	33.57	383	49	P	V
		5725.64	48.5	-5.5	54	39.11	32.31	10.65	33.57	383	49	A	V
<b>Remark</b>	1. No other spurious found. 2. All results are PASS against Peak and Average limit line.												



**Band 3 - 5470~5725MHz**  
**WIFI 802.11n HT40 (Harmonic @ 3m)**

WIFI Ant. 1	Note	Frequency ( MHz )	Level ( dBμV/m )	Over Limit ( dB )	Limit Line ( dBμV/m )	Read Level ( dBμV )	Antenna Factor ( dB/m )	Cable Loss ( dB )	Preamp Factor ( dB )	Ant Pos ( cm )	Table Pos ( deg )	Peak Avg. ( P/A )	Pol. ( H/V )
802.11n HT40 CH 102 5510MHz		11020	42.07	-31.93	74	53.47	40.29	15.27	66.96	100	0	P	H
		16530	37.06	-31.24	68.3	43.74	39	18.31	63.99	100	0	P	H
													H
													H
		11020	43	-31	74	54.4	40.29	15.27	66.96	100	0	P	V
		16530	37.72	-30.58	68.3	44.4	39	18.31	63.99	100	0	P	V
802.11n HT40 CH 110 5550MHz		11100	42.35	-31.65	74	53.54	40.22	15.33	66.74	100	0	P	H
		16650	38.45	-35.55	74	44.7	39.33	18.36	63.94	100	0	P	H
													H
													H
		11100	43.31	-30.69	74	54.5	40.22	15.33	66.74	100	0	P	V
		16650	38.15	-35.85	74	44.4	39.33	18.36	63.94	100	0	P	V
802.11n HT40 CH 134 5670MHz		11340	41.73	-32.27	74	52.35	40.03	15.48	66.13	100	0	P	H
		17010	39.74	-34.26	74	44.71	40.35	18.5	63.82	100	0	P	H
													H
													H
		11340	42.02	-31.98	74	52.64	40.03	15.48	66.13	100	0	P	V
		17010	40.6	-33.4	74	45.57	40.35	18.5	63.82	100	0	P	V
Remark	1. No other spurious found.												
	2. All results are PASS against Peak and Average limit line.												



**Band 3 - 5470~5725MHz**

**Emission below 1GHz**

**WIFI 802.11a (LF @ 3m)**

WIFI Ant.	Note	Frequency	Level	Over Limit	Limit Line	Read Level	Antenna Factor	Cable Loss	Preamp Factor	Ant Pos	Table Pos	Peak Avg.	Pol.	
1		( MHz )	( dBµV/m )	( dB )	( dBµV/m )	( dBµV )	( dB/m )	( dB )	( dB )	( cm )	( deg )	( P/A )	( H/V )	
802.11a LF		90.48	29.01	-14.49	43.5	44.72	14.9	1.17	31.78			P	H	
		136.38	39.17	-4.33	43.5	51.54	17.93	1.48	31.78	165	38	P	H	
		224.13	37.37	-8.63	46	50.69	16.48	1.98	31.78			P	H	
		414.1	24.04	-21.96	46	30.61	22.66	2.58	31.81			P	H	
		583.5	26.58	-19.42	46	30.02	25.41	3.16	32.01			P	H	
		911.1	32.15	-13.85	46	30.13	29.5	3.86	31.34			P	H	
														H
														H
														H
														H
														H
														H
			39.72	34.89	-5.11	40	45.48	20.3	0.93	31.82	155	40	P	V
			90.21	32.41	-11.09	43.5	48.12	14.9	1.17	31.78			P	V
			223.59	32.94	-13.06	46	46.26	16.48	1.98	31.78			P	V
			394.5	23.09	-22.91	46	30.04	22.27	2.58	31.8			P	V
			570.2	26.25	-19.75	46	30.06	25.16	3.03	32			P	V
			950.3	32.81	-13.19	46	29.35	30.6	3.89	31.03			P	V
													V	
													V	
													V	
													V	
													V	
													V	
Remark	1. No other spurious found. 2. All results are PASS against limit line.													



**Note symbol**

*	<b>Fundamental Frequency</b> which can be ignored. However, the level of any unwanted emissions shall not exceed the level of the fundamental frequency.
!	Test result is <b>over limit</b> line.
P/A	<b>Peak</b> or <b>Average</b>
H/V	<b>Horizontal</b> or <b>Vertical</b>



A calculation example for radiated spurious emission is shown as below:

WIFI	Note	Frequency	Level	Over	Limit	Read	Antenna	Cable	Preamp	Ant	Table	Peak	Pol.
Ant.				Limit	Line	Level	Factor	Loss	Factor	Pos	Pos	Avg.	
1		( MHz )	( dBμV/m )	( dB )	( dBμV/m )	( dBμV )	( dB/m )	( dB )	( dB )	( cm )	( deg )	( P/A )	( H/V )
802.11b		2390	55.45	-18.55	74	54.51	32.22	4.58	35.86	103	308	P	H
CH 01													
2412MHz		2390	43.54	-10.46	54	42.6	32.22	4.58	35.86	103	308	A	H

- Level(dBμV/m) =  
Antenna Factor(dB/m) + Cable Loss(dB) + Read Level(dBμV) - Preamp Factor(dB)
- Over Limit(dB) = Level(dBμV/m) – Limit Line(dBμV/m)

**For Peak Limit @ 2390MHz:**

- Level(dBμV/m)  
= Antenna Factor(dB/m) + Cable Loss(dB) + Read Level(dBμV) - Preamp Factor(dB)  
= 32.22(dB/m) + 4.58(dB) + 54.51(dBμV) – 35.86 (dB)  
= 55.45 (dBμV/m)
- Over Limit(dB)  
= Level(dBμV/m) – Limit Line(dBμV/m)  
= 55.45(dBμV/m) – 74(dBμV/m)  
= -18.55(dB)

**For Average Limit @ 2390MHz:**

- Level(dBμV/m)  
= Antenna Factor(dB/m) + Cable Loss(dB) + Read Level(dBμV) - Preamp Factor(dB)  
= 32.22(dB/m) + 4.58(dB) + 42.6(dBμV) – 35.86 (dB)  
= 43.54 (dBμV/m)
- Over Limit(dB)  
= Level(dBμV/m) – Limit Line(dBμV/m)  
= 43.54(dBμV/m) – 54(dBμV/m)  
= -10.46(dB)

Both peak and average measured complies with the limit line, so test result is “PASS”.



## Appendix C. Radiated Spurious Emission

### Note symbol

-L	Low channel location
-R	High channel location



**Band 1 - 5150~5250MHz**  
**WIFI 802.11a (Band Edge @ 3m)**

WIFI	Band 1 5150~5250MHz Band Edge @ 3m	
ANT	802.11a CH36 5180MHz	
<b>1</b>	<b>Horizontal</b>	<b>Fundamental</b>
<b>Peak</b>	<p>Site : 03CH11-HY            Condition : FCC CLASS-B 3m HORN 9120D-HF HORIZONTAL            RBW:1000.000KHz VBW:3000.000KHz SWT:Auto            Detector : Peak            Project : 651612            Mode : 1</p>	<p>Site : 03CH11-HY            Condition : FCC CLASS-B 3m HORN 9120D-HF HORIZONTAL            RBW:1000.000KHz VBW:3000.000KHz SWT:Auto            Detector : Peak            Project : 651612            Mode : 1</p>
<b>Avg.</b>	<p>Site : 03CH11-HY            Condition : FCC CLASS-B (AVG) 3m HORN 9120D-HF HORIZONTAL            RBW:1000.000KHz VBW:1.000KHz SWT:Auto            Detector : Peak            Project : 651612            Mode : 1</p>	<b>Left blank</b>



WIFI	Band 1 5150~5250MHz Band Edge @ 3m	
ANT	802.11a CH36 5180MHz	
1	Vertical	Fundamental
Peak	<p>Site : 03CH11-HY            Condition : FCC CLASS-B 3m HORN 9120D-HF VERTICAL            RBW:1000.000KHz VBW:3000.000KHz SWT:Auto            Detector : Peak            Project : 651612            Mode : 1</p>	<p>Site : 03CH11-HY            Condition : FCC CLASS-B 3m HORN 9120D-HF VERTICAL            RBW:1000.000KHz VBW:3000.000KHz SWT:Auto            Detector : Peak            Project : 651612            Mode : 1</p>
Avg.	<p>Site : 03CH11-HY            Condition : FCC CLASS-B (AVG) 3m HORN 9120D-HF VERTICAL            RBW:1000.000KHz VBW:1000KHz SWT:Auto            Detector : Peak            Project : 651612            Mode : 1</p>	Left blank

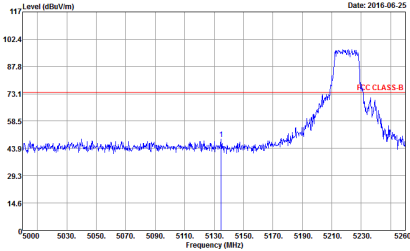
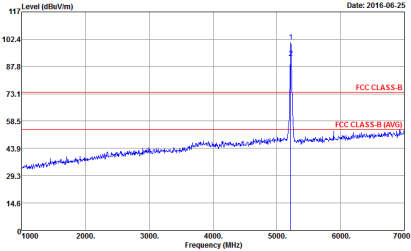
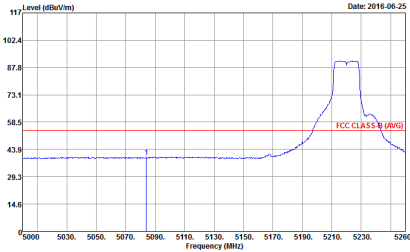

WIFI	Band 1 5150~5250MHz Band Edge @ 3m	
ANT	802.11a CH44 5220MHz - L	
1	Horizontal	Fundamental
Peak	 <p>Date: 2016-06-25</p> <p>Site : 03CH11-HY            Condition : FCC CLASS-B 3m HORN 9120D-HF HORIZONTAL            RBW:1000.000KHz VBW:3000.000KHz SWT:Auto            Detector : Peak            Project : 651612            Mode : 2</p>	 <p>Date: 2016-06-25</p> <p>Site : 03CH11-HY            Condition : FCC CLASS-B 3m HORN 9120D-HF HORIZONTAL            RBW:1000.000KHz VBW:3000.000KHz SWT:Auto            Detector : Peak            Project : 651612            Mode : 2</p>
Avg.	 <p>Date: 2016-06-25</p> <p>Site : 03CH11-HY            Condition : FCC CLASS-B (AVG) 3m HORN 9120D-HF HORIZONTAL            RBW:1000.000KHz VBW:1000KHz SWT:Auto            Detector : Peak            Project : 651612            Mode : 2</p>	Left blank

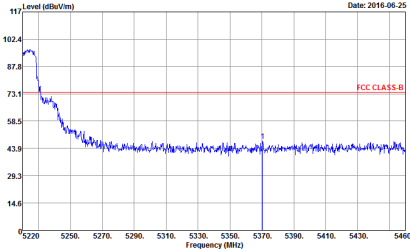
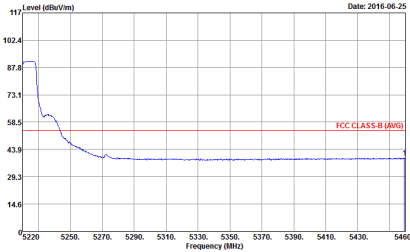

WIFI	Band 1 5150~5250MHz Band Edge @ 3m	
ANT	802.11a CH44 5220MHz - R	
1	Horizontal	Fundamental
Peak	 <p>Date: 2016-06-25</p> <p>Site : 03CH11-HY  Condition : FCC CLASS-B 3m HORN 9120D-HF HORIZONTAL  RBW:1000.000KHz VBW:3000.000KHz SWT:Auto  Detector : Peak  Project : 651612  Mode : 2</p>	Left blank
Avg.	 <p>Date: 2016-06-25</p> <p>Site : 03CH11-HY  Condition : FCC CLASS-B (AVG) 3m HORN 9120D-HF HORIZONTAL  RBW:1000.000KHz VBW:1000KHz SWT:Auto  Detector : Peak  Project : 651612  Mode : 2</p>	Left blank

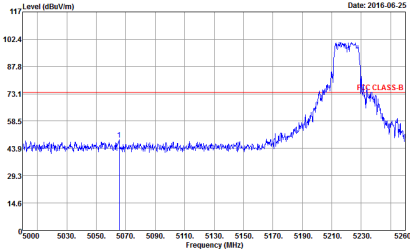
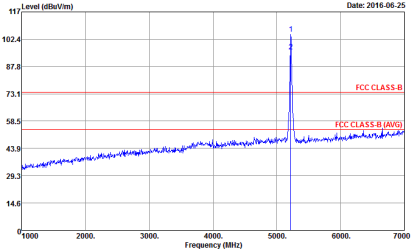
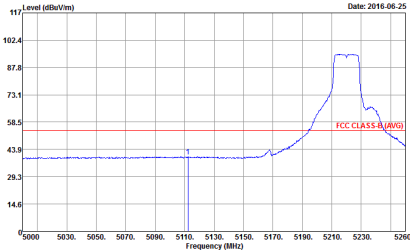

WIFI	Band 1 5150~5250MHz Band Edge @ 3m	
ANT	802.11a CH44 5220MHz - L	
1	Vertical	Fundamental
Peak	 <p>Date: 2016-06-25</p> <p>Site : 03CH11-HY            Condition : FCC CLASS-B 3m HORN 9120D-HF VERTICAL            RBW:1000.000KHz VBW:3000.000KHz SWT:Auto            Detector : Peak            Project : 651612            Mode : 2</p>	 <p>Date: 2016-06-25</p> <p>Site : 03CH11-HY            Condition : FCC CLASS-B 3m HORN 9120D-HF VERTICAL            RBW:1000.000KHz VBW:3000.000KHz SWT:Auto            Detector : Peak            Project : 651612            Mode : 2</p>
Avg.	 <p>Date: 2016-06-25</p> <p>Site : 03CH11-HY            Condition : FCC CLASS-B (AVG) 3m HORN 9120D-HF VERTICAL            RBW:1000.000KHz VBW:1000KHz SWT:Auto            Detector : Peak            Project : 651612            Mode : 2</p>	Left blank

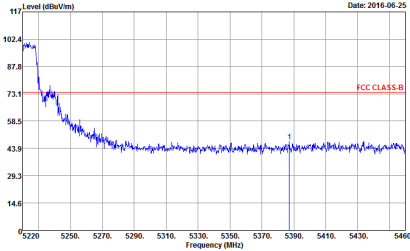
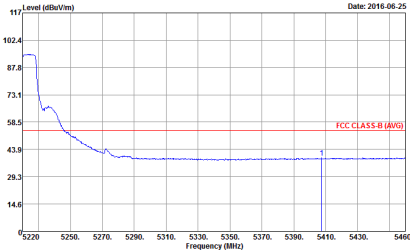

WIFI	Band 1 5150~5250MHz Band Edge @ 3m	
ANT	802.11a CH44 5220MHz - R	
1	Vertical	Fundamental
Peak	 <p>           Date: 2016-06-25            Site : 03CH11-HY            Condition : FCC CLASS-B 3m HORN 9120D-HF VERTICAL            RBW:1000.000KHz VBW:3000.000KHz SWT:Auto            Detector : Peak            Project : 651612            Mode : 2         </p>	Left blank
Avg.	 <p>           Date: 2016-06-25            Site : 03CH11-HY            Condition : FCC CLASS-B (AVG) 3m HORN 9120D-HF VERTICAL            RBW:1000.000KHz VBW:1000KHz SWT:Auto            Detector : Peak            Project : 651612            Mode : 2         </p>	Left blank

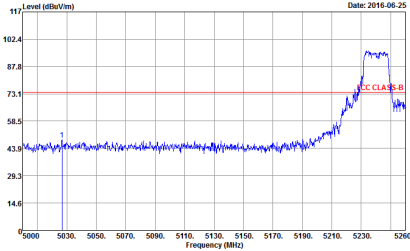
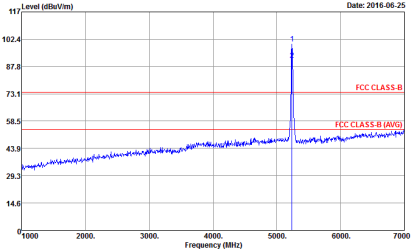
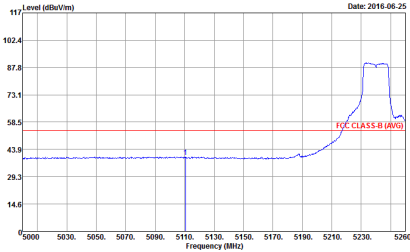

WIFI	Band 1 5150~5250MHz Band Edge @ 3m	
ANT	802.11a CH48 5240MHz - L	
1	Horizontal	Fundamental
Peak	 <p>Date: 2016-06-25</p> <p>Site : 03CH11-HY            Condition : FCC CLASS-B 3m HORN 9120D-HF HORIZONTAL            RBW:1000.000KHz VBW:3000.000KHz SWT:Auto            Detector : Peak            Project : 651612            Mode : 3</p>	 <p>Date: 2016-06-25</p> <p>Site : 03CH11-HY            Condition : FCC CLASS-B 3m HORN 9120D-HF HORIZONTAL            RBW:1000.000KHz VBW:3000.000KHz SWT:Auto            Detector : Peak            Project : 651612            Mode : 3</p>
Avg.	 <p>Date: 2016-06-25</p> <p>Site : 03CH11-HY            Condition : FCC CLASS-B (AVG) 3m HORN 9120D-HF HORIZONTAL            RBW:1000.000KHz VBW:1000KHz SWT:Auto            Detector : Peak            Project : 651612            Mode : 3</p>	Left blank

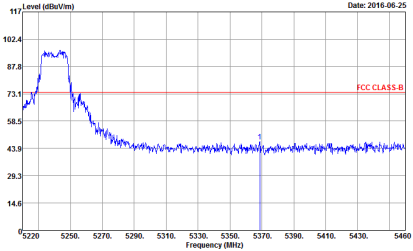
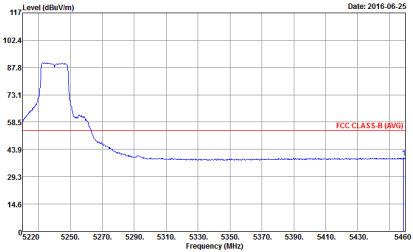

WIFI	Band 1 5150~5250MHz Band Edge @ 3m	
ANT	802.11a CH48 5240MHz - R	
1	Horizontal	Fundamental
Peak	 <p>           Site : 03CH11-HY            Condition : FCC CLASS-B 3m HORN 9120D-HF HORIZONTAL            Detector : Peak            Project : 651612            Mode : 3         </p>	Left blank
Avg.	 <p>           Site : 03CH11-HY            Condition : FCC CLASS-B (AVG) 3m HORN 9120D-HF HORIZONTAL            Detector : Peak            Project : 651612            Mode : 3         </p>	Left blank

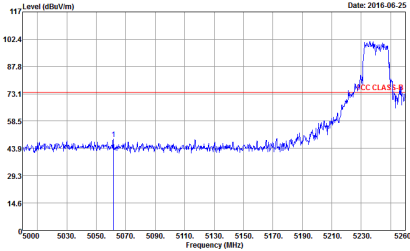
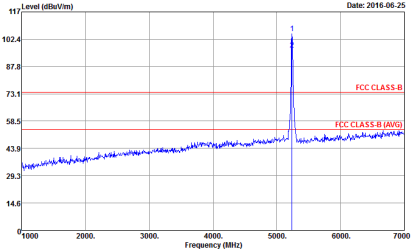
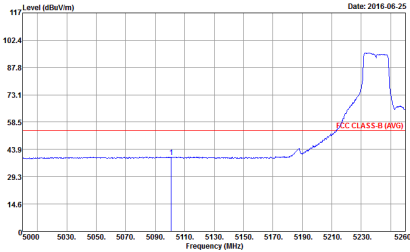

WIFI	Band 1 5150~5250MHz Band Edge @ 3m	
ANT	802.11a CH48 5240MHz - L	
1	Vertical	Fundamental
Peak	 <p>Date: 2016-06-25</p> <p>Site : 03CH11-HY            Condition : FCC CLASS-B 3m HORN 9120D-HF VERTICAL            RBW:1000.000KHz VBW:3000.000KHz SWT:Auto            Detector : Peak            Project : 651612            Mode : 3</p>	 <p>Date: 2016-06-25</p> <p>Site : 03CH11-HY            Condition : FCC CLASS-B 3m HORN 9120D-HF VERTICAL            RBW:1000.000KHz VBW:3000.000KHz SWT:Auto            Detector : Peak            Project : 651612            Mode : 3</p>
Avg.	 <p>Date: 2016-06-25</p> <p>Site : 03CH11-HY            Condition : FCC CLASS-B (AVG) 3m HORN 9120D-HF VERTICAL            RBW:1000.000KHz VBW:1000KHz SWT:Auto            Detector : Peak            Project : 651612            Mode : 3</p>	Left blank

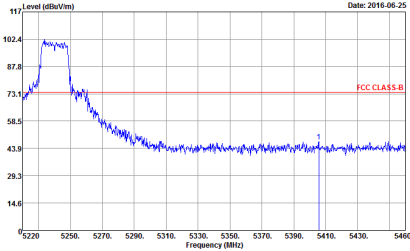
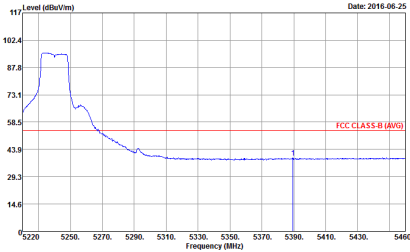

WIFI	Band 1 5150~5250MHz Band Edge @ 3m	
ANT	802.11a CH48 5240MHz - R	
1	Vertical	Fundamental
Peak	 <p>Site : 03CH11-HY            Condition : FCC CLASS-B 3m HORN 9120D-HF VERTICAL            RBW:1000.000KHz VBW:3000.000KHz SWT:Auto            Detector : Peak            Project : 651612            Mode : 3</p>	Left blank
Avg.	 <p>Site : 03CH11-HY            Condition : FCC CLASS-B (AVG) 3m HORN 9120D-HF VERTICAL            RBW:1000.000KHz VBW:1000KHz SWT:Auto            Detector : Peak            Project : 651612            Mode : 3</p>	Left blank

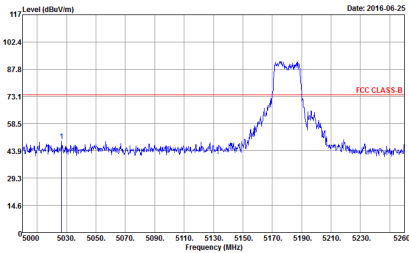
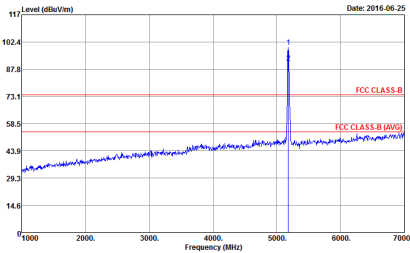
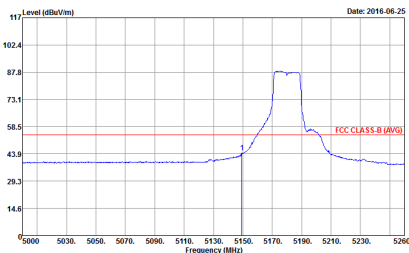

**Band 1 5150~5250MHz**  
**WIFI 802.11n HT20 (Band Edge @ 3m)**

WIFI	Band 1 5150~5250MHz Band Edge @ 3m	
ANT	802.11n HT20 CH36 5180MHz	
1	Horizontal	Fundamental
<p><b>Peak</b></p>	 <p>Site : 03CH11-HY            Condition : FCC CLASS-B 3m HORN 9120D-HF HORIZONTAL            Detector : Peak            Project : 651612            Mode : 10</p>	 <p>Site : 03CH11-HY            Condition : FCC CLASS-B 3m HORN 9120D-HF HORIZONTAL            Detector : Peak            Project : 651612            Mode : 10</p>
<p><b>Avg.</b></p>	 <p>Site : 03CH11-HY            Condition : FCC CLASS-B (AVG) 3m HORN 9120D-HF HORIZONTAL            Detector : Peak            Project : 651612            Mode : 10</p>	<p align="center">Left blank</p>

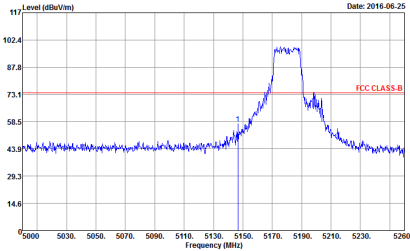
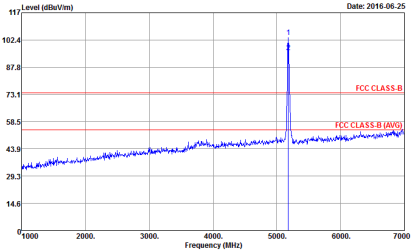
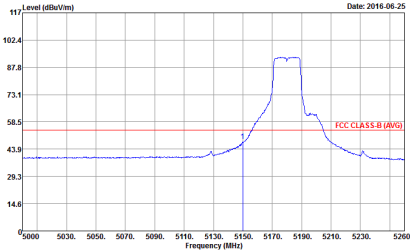

WIFI	Band 1 5150~5250MHz Band Edge @ 3m	
ANT	802.11n HT20 CH36 5180MHz	
1	Vertical	Fundamental
Peak	 <p>Date: 2016-06-25</p> <p>Site : 03CH11-HY            Condition : FCC CLASS-B 3m HORN 9120D-HF VERTICAL            RBW:1000.000KHz VBW:3000.000KHz SWT:Auto            Detector : Peak            Project : 651612            Mode : 10</p>	 <p>Date: 2016-06-25</p> <p>Site : 03CH11-HY            Condition : FCC CLASS-B 3m HORN 9120D-HF VERTICAL            RBW:1000.000KHz VBW:3000.000KHz SWT:Auto            Detector : Peak            Project : 651612            Mode : 10</p>
Avg.	 <p>Date: 2016-06-25</p> <p>Site : 03CH11-HY            Condition : FCC CLASS-B (AVG) 3m HORN 9120D-HF VERTICAL            RBW:1000.000KHz VBW:1000KHz SWT:Auto            Detector : Peak            Project : 651612            Mode : 10</p>	Left blank

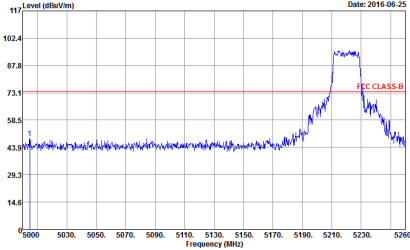
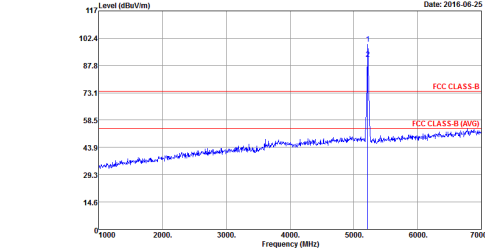
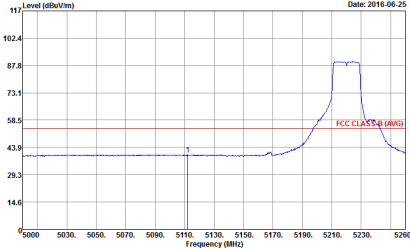

WIFI	Band 1 5150~5250MHz Band Edge @ 3m	
ANT	802.11n HT20 CH44 5220MHz - L	
1	Horizontal	Fundamental
Peak	 <p>Site : 03CH11-HY            Condition : FCC CLASS-B 3m HORN 9120D-HF HORIZONTAL            RBW:1000.000KHz VBW:3000.000KHz SWT:Auto            Detector : Peak            Project : 651612            Mode : II</p>	 <p>Site : 03CH11-HY            Condition : FCC CLASS-B 3m HORN 9120D-HF HORIZONTAL            RBW:1000.000KHz VBW:3000.000KHz SWT:Auto            Detector : Peak            Project : 651612            Mode : II</p>
Avg.	 <p>Site : 03CH11-HY            Condition : FCC CLASS-B (AVG) 3m HORN 9120D-HF HORIZONTAL            RBW:1000.000KHz VBW:1000KHz SWT:Auto            Detector : Peak            Project : 651612            Mode : II</p>	Left blank

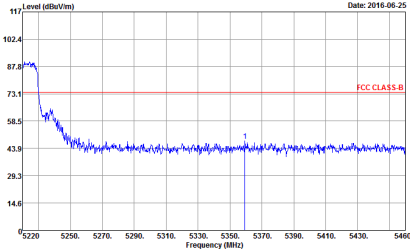
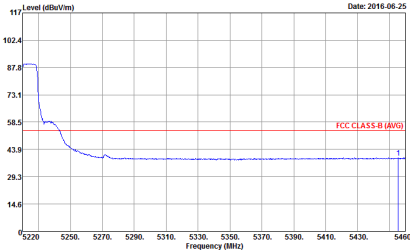

WIFI	Band 1 5150~5250MHz Band Edge @ 3m	
ANT	802.11n HT20 CH44 5220MHz - R	
1	Horizontal	Fundamental
Peak	 <p>           Site : 03CH11-HY            Condition : FCC CLASS-B 3m HORN 9120D-HF HORIZONTAL            Detector : Peak            Project : 651612            Mode : II         </p>	Left blank
Avg.	 <p>           Site : 03CH11-HY            Condition : FCC CLASS-B (AVG) 3m HORN 9120D-HF HORIZONTAL            Detector : Peak            Project : 651612            Mode : II         </p>	Left blank

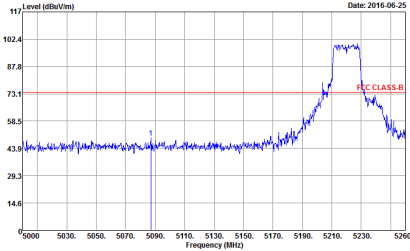
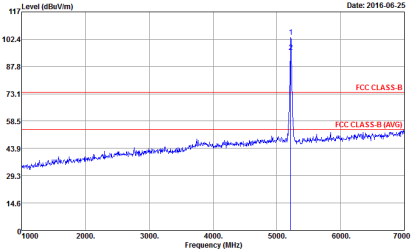
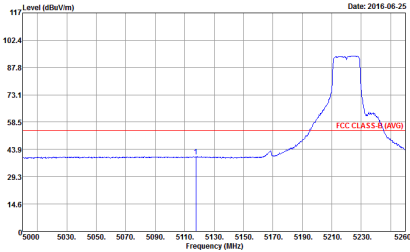

WIFI	Band 1 5150~5250MHz Band Edge @ 3m	
ANT	802.11n HT20 CH44 5220MHz - L	
1	Vertical	Fundamental
Peak	 <p>Date: 2016-06-25</p> <p>Site : 03CH11-HY  Condition : FCC CLASS-B 3m HORN 9120D-HF VERTICAL  RBW:1000.000KHz VBW:3000.000KHz SWT:Auto  Detector : Peak  Project : 651612  Mode : 11</p>	 <p>Date: 2016-06-25</p> <p>Site : 03CH11-HY  Condition : FCC CLASS-B 3m HORN 9120D-HF VERTICAL  RBW:1000.000KHz VBW:3000.000KHz SWT:Auto  Detector : Peak  Project : 651612  Mode : 11</p>
Avg.	 <p>Date: 2016-06-25</p> <p>Site : 03CH11-HY  Condition : FCC CLASS-B (AVG) 3m HORN 9120D-HF VERTICAL  RBW:1000.000KHz VBW:1000KHz SWT:Auto  Detector : Peak  Project : 651612  Mode : 11</p>	Left blank

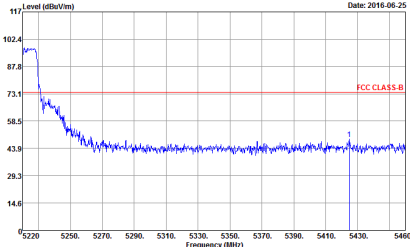
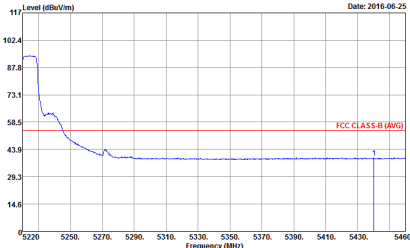

WIFI	Band 1 5150~5250MHz Band Edge @ 3m	
ANT	802.11n HT20 CH44 5220MHz - R	
1	Vertical	Fundamental
Peak	 <p>Site : 03CH11-HY            Condition : FCC CLASS-B 3m HORN 9120D-HF VERTICAL            RBW:1000.000KHz VBW:3000.000KHz SWT:Auto            Detector : Peak            Project : 651612            Mode : II</p>	Left blank
Avg.	 <p>Site : 03CH11-HY            Condition : FCC CLASS-B (AVG) 3m HORN 9120D-HF VERTICAL            RBW:1000.000KHz VBW:1000KHz SWT:Auto            Detector : Peak            Project : 651612            Mode : II</p>	Left blank

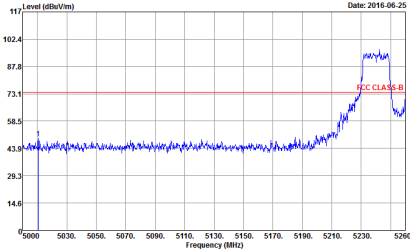
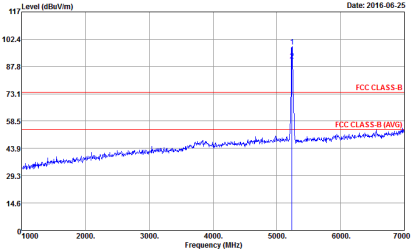
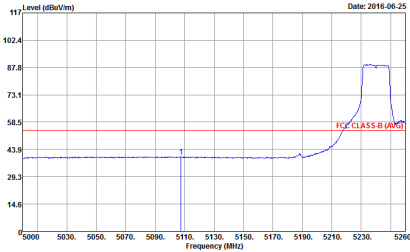

WIFI	Band 1 5150~5250MHz Band Edge @ 3m	
ANT	802.11n HT20 CH48 5240MHz - L	
1	Horizontal	Fundamental
Peak	 <p>Date: 2016-06-25</p> <p>Site : 03CH11-HY            Condition : FCC CLASS-B 3m HORN 9120D-HF HORIZONTAL            RBW:1000.000KHz VBW:3000.000KHz SWT:Auto            Detector : Peak            Project : 651612            Mode : 12</p>	 <p>Date: 2016-06-25</p> <p>Site : 03CH11-HY            Condition : FCC CLASS-B 3m HORN 9120D-HF HORIZONTAL            RBW:1000.000KHz VBW:3000.000KHz SWT:Auto            Detector : Peak            Project : 651612            Mode : 12</p>
Avg.	 <p>Date: 2016-06-25</p> <p>Site : 03CH11-HY            Condition : FCC CLASS-B (AVG) 3m HORN 9120D-HF HORIZONTAL            RBW:1000.000KHz VBW:1000KHz SWT:Auto            Detector : Peak            Project : 651612            Mode : 12</p>	Left blank

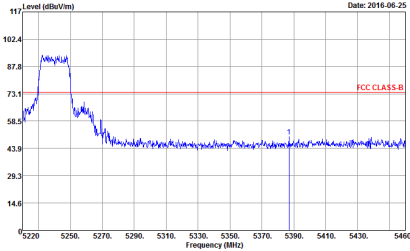
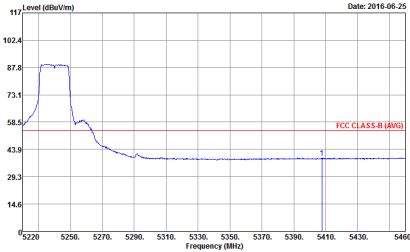

WIFI	Band 1 5150~5250MHz Band Edge @ 3m	
ANT	802.11n HT20 CH48 5240MHz - R	
1	Horizontal	Fundamental
Peak	 <p>           Site : 03CH11-HY            Condition : FCC CLASS-B 3m HORN 9120D-HF HORIZONTAL            RBW:1000.000KHz VBW:3000.000KHz SWT:Auto            Detector : Peak            Project : 651612            Mode : 12         </p>	Left blank
Avg.	 <p>           Site : 03CH11-HY            Condition : FCC CLASS-B (AVG) 3m HORN 9120D-HF HORIZONTAL            RBW:1000.000KHz VBW:1000KHz SWT:Auto            Detector : Peak            Project : 651612            Mode : 12         </p>	Left blank

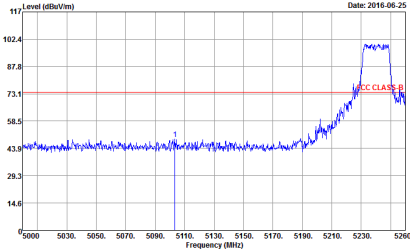
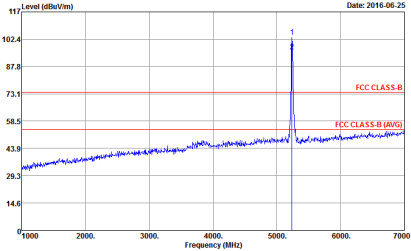
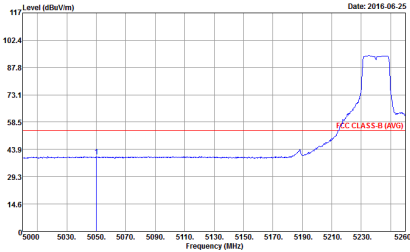

WIFI	Band 1 5150~5250MHz Band Edge @ 3m	
ANT	802.11n HT20 CH48 5240MHz - L	
1	Vertical	Fundamental
Peak	 <p>Date: 2016-06-25</p> <p>Site : 03CH11-HY            Condition : FCC CLASS-B 3m HORN 9120D-HF VERTICAL            RBW:1000.000KHz VBW:3000.000KHz SWT:Auto            Detector : Peak            Project : 651612            Mode : 12</p>	 <p>Date: 2016-06-25</p> <p>Site : 03CH11-HY            Condition : FCC CLASS-B 3m HORN 9120D-HF VERTICAL            RBW:1000.000KHz VBW:3000.000KHz SWT:Auto            Detector : Peak            Project : 651612            Mode : 12</p>
Avg.	 <p>Date: 2016-06-25</p> <p>Site : 03CH11-HY            Condition : FCC CLASS-B (AVG) 3m HORN 9120D-HF VERTICAL            RBW:1000.000KHz VBW:1000KHz SWT:Auto            Detector : Peak            Project : 651612            Mode : 12</p>	Left blank

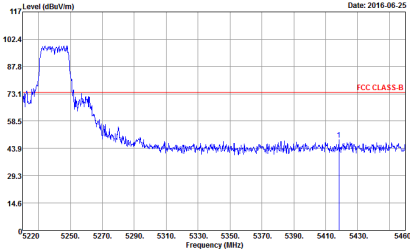
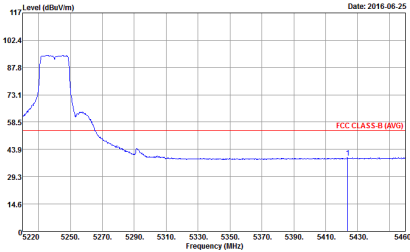

WIFI	Band 1 5150~5250MHz Band Edge @ 3m	
ANT	802.11n HT20 CH48 5240MHz - R	
1	Vertical	Fundamental
Peak	 <p>Date: 2016-06-25</p> <p>Site : 03CH11-HY  Condition : FCC CLASS-B 3m HORN 9120D-HF VERTICAL  RBW:1000.000KHz VBW:3000.000KHz SWT:Auto  Detector : Peak  Project : 651612  Mode : 12</p>	Left blank
Avg.	 <p>Date: 2016-06-25</p> <p>Site : 03CH11-HY  Condition : FCC CLASS-B (AVG) 3m HORN 9120D-HF VERTICAL  RBW:1000.000KHz VBW:1000KHz SWT:Auto  Detector : Peak  Project : 651612  Mode : 12</p>	Left blank



**Band 1 5150~5250MHz  
WIFI 802.11n HT40 (Band Edge @ 3m)**

WIFI	Band 1 5150~5250MHz Band Edge @ 3m	
ANT	802.11n HT40 CH38 5190MHz - L	
<p align="center"><b>1</b></p>	<p align="center"><b>Horizontal</b></p> <p>Site : 03CH11-HY Condition : FCC CLASS-B 3m HORN 9120D-HF HORIZONTAL Detector : Peak Project : 651612 Mode : 19 Setting : 14</p>	<p align="center"><b>Fundamental</b></p> <p>Site : 03CH11-HY Condition : FCC CLASS-B 3m HORN 9120D-HF HORIZONTAL Detector : Peak Project : 651612 Mode : 19 Setting : 14</p>
<p align="center"><b>Avg.</b></p>	<p>Site : 03CH11-HY Condition : FCC CLASS-B (AVG) 3m HORN 9120D-HF HORIZONTAL Detector : Peak Project : 651612 Mode : 19 Setting : 14</p>	<p align="center"><b>Left blank</b></p>



WIFI	Band 1 5150~5250MHz Band Edge @ 3m	
ANT	802.11n HT40 CH38 5190MHz - R	
1	Horizontal	Fundamental
Peak	<p>Site : 03CH11-HY            Condition : FCC CLASS-B 3m HORN 9120D-HF HORIZONTAL            RBW:1000.000KHz VBW:3000.000KHz SWT:Auto            Detector : Peak            Project : 651612            Mode : 19            Setting : 14</p>	Left blank
Avg.	<p>Site : 03CH11-HY            Condition : FCC CLASS-B (AVG) 3m HORN 9120D-HF HORIZONTAL            RBW:1000.000KHz VBW:3.000KHz SWT:Auto            Detector : Peak            Project : 651612            Mode : 19            Setting : 14</p>	Left blank

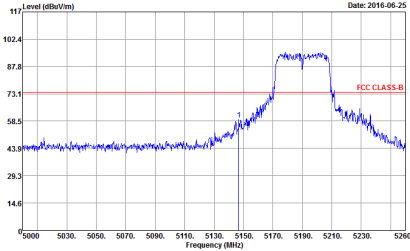
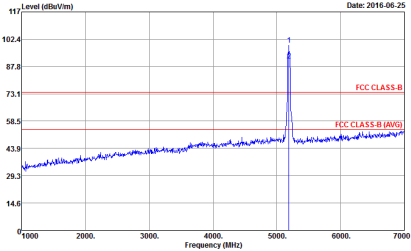
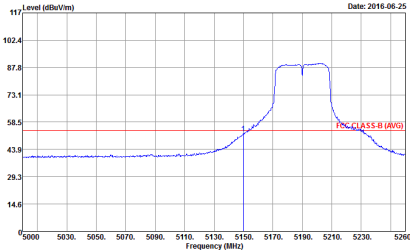

WIFI	Band 1 5150~5250MHz Band Edge @ 3m	
ANT	802.11n HT40 CH38 5190MHz - L	
1	Vertical	Fundamental
Peak	 <p>Site : 03CH11-HY            Condition : FCC CLASS-B 3m HORN 9120D-HF VERTICAL            RBW:1000.000KHz VBW:3000.000KHz SWT:Auto            Detector : Peak            Project : 651612            Mode : 19            Setting : 14</p>	 <p>Site : 03CH11-HY            Condition : FCC CLASS-B 3m HORN 9120D-HF VERTICAL            RBW:1000.000KHz VBW:3000.000KHz SWT:Auto            Detector : Peak            Project : 651612            Mode : 19            Setting : 14</p>
Avg.	 <p>Site : 03CH11-HY            Condition : FCC CLASS-B (AVG) 3m HORN 9120D-HF VERTICAL            RBW:1000.000KHz VBW:3.000KHz SWT:Auto            Detector : Peak            Project : 651612            Mode : 19            Setting : 14</p>	Left blank

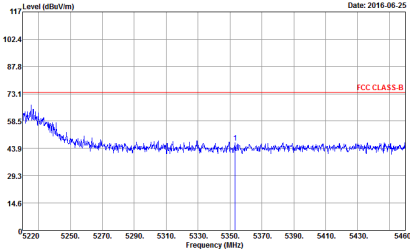
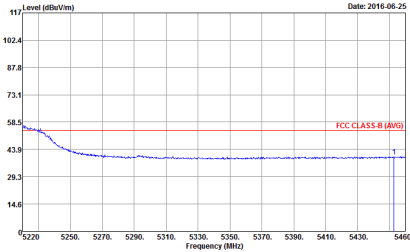

WIFI	Band 1 5150~5250MHz Band Edge @ 3m	
ANT	802.11n HT40 CH38 5190MHz - R	
1	Vertical	Fundamental
Peak	 <p>Date: 2016-06-25</p> <p>Site : 03CH11-HY  Condition : FCC CLASS-B 3m HORN 9120D-HF VERTICAL  RBW:1000.000KHz VBW:3000.000KHz SWT:Auto  Detector : Peak  Project : 651612  Mode : 19  Setting : 14</p>	Left blank
Avg.	 <p>Date: 2016-06-25</p> <p>Site : 03CH11-HY  Condition : FCC CLASS-B (AVG) 3m HORN 9120D-HF VERTICAL  RBW:1000.000KHz VBW:3.000KHz SWT:Auto  Detector : Peak  Project : 651612  Mode : 19  Setting : 14</p>	Left blank

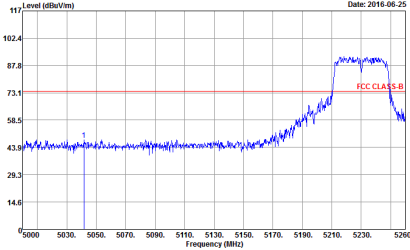
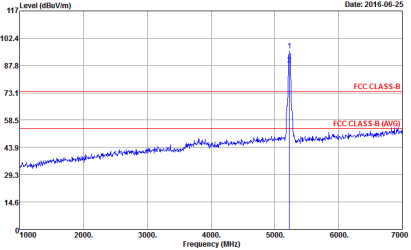
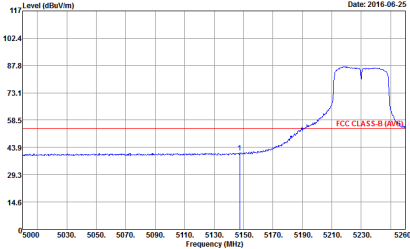

WIFI	Band 1 5150~5250MHz Band Edge @ 3m	
ANT	802.11n HT40 CH46 5230MHz - L	
1	Horizontal	Fundamental
Peak	 <p>Site : 03CH11-HY            Condition : FCC CLASS-B 3m HORN 9120D-HF HORIZONTAL            RBW:1000.000KHz VBW:3000.000KHz SWT:Auto            Detector : Peak            Project : 651612            Mode : 20</p>	 <p>Site : 03CH11-HY            Condition : FCC CLASS-B 3m HORN 9120D-HF HORIZONTAL            RBW:1000.000KHz VBW:3000.000KHz SWT:Auto            Detector : Peak            Project : 651612            Mode : 20</p>
Avg.	 <p>Site : 03CH11-HY            Condition : FCC CLASS-B (AVG) 3m HORN 9120D-HF HORIZONTAL            RBW:1000.000KHz VBW:3.000KHz SWT:Auto            Detector : Peak            Project : 651612            Mode : 20</p>	Left blank

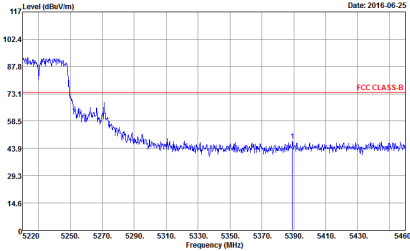
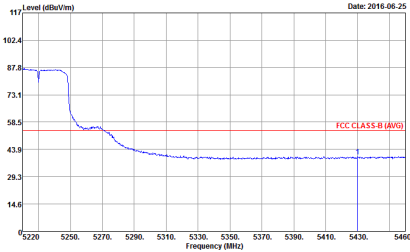

WIFI	Band 1 5150~5250MHz Band Edge @ 3m	
ANT	802.11n HT40 CH46 5230MHz - R	
1	Horizontal	Fundamental
Peak	 <p>Site : 03CH11-HY            Condition : FCC CLASS-B 3m HORN 9120D-HF HORIZONTAL            RBW:1000.000KHz VBW:3000.000KHz SWT:Auto            Detector : Peak            Project : 651612            Mode : Z0</p>	Left blank
Avg.	 <p>Site : 03CH11-HY            Condition : FCC CLASS-B (AVG) 3m HORN 9120D-HF HORIZONTAL            RBW:1000.000KHz VBW:3.000KHz SWT:Auto            Detector : Peak            Project : 651612            Mode : Z0</p>	Left blank

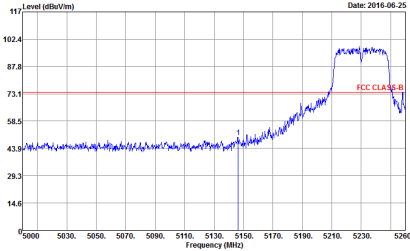
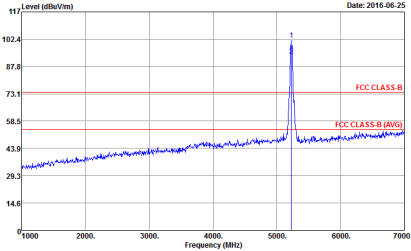
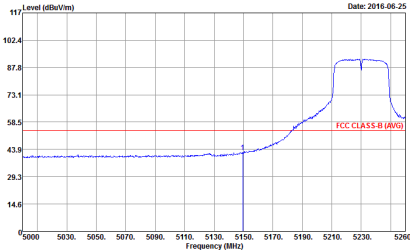

WIFI	Band 1 5150~5250MHz Band Edge @ 3m	
ANT	802.11n HT40 CH46 5230MHz - L	
1	Vertical	Fundamental
Peak	 <p>Site : 03CH11-HY            Condition : FCC CLASS-B 3m HORN 9120D-HF VERTICAL            RBW:1000.000KHz VBW:3000.000KHz SWT:Auto            Detector : Peak            Project : 651612            Mode : 20</p>	 <p>Site : 03CH11-HY            Condition : FCC CLASS-B 3m HORN 9120D-HF VERTICAL            RBW:1000.000KHz VBW:3000.000KHz SWT:Auto            Detector : Peak            Project : 651612            Mode : 20</p>
Avg.	 <p>Site : 03CH11-HY            Condition : FCC CLASS-B (AVG) 3m HORN 9120D-HF VERTICAL            RBW:1000.000KHz VBW:3.000KHz SWT:Auto            Detector : Peak            Project : 651612            Mode : 20</p>	Left blank

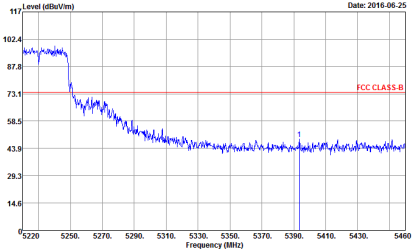
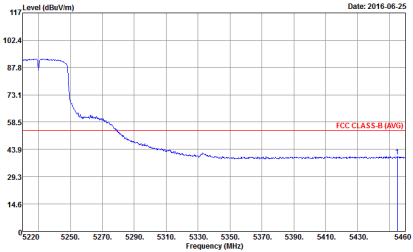

WIFI	Band 1 5150~5250MHz Band Edge @ 3m	
ANT	802.11n HT40 CH46 5230MHz - R	
1	Vertical	Fundamental
Peak	 <p>           Site : 03CH11-HY            Condition : FCC CLASS-B 3m HORN 9120D-HF VERTICAL            RBW:1000.000KHz VBW:3000.000KHz SWT:Auto            Detector : Peak            Project : 651612            Mode : Z0         </p>	Left blank
Avg.	 <p>           Site : 03CH11-HY            Condition : FCC CLASS-B (AVG) 3m HORN 9120D-HF VERTICAL            RBW:1000.000KHz VBW:3.000KHz SWT:Auto            Detector : Peak            Project : 651612            Mode : Z0         </p>	Left blank



**Band 1 - 5150~5250MHz**  
**WIFI 802.11a (Harmonic @ 3m)**

WIFI	Band 1 5150~5250MHz Harmonic @ 3m	
ANT	802.11a CH36 5180MHz	
1	Horizontal	Vertical
<p><b>Peak</b></p> <p><b>Avg.</b></p>	<p>Site : 03CH11-HY            Condition : FCC CLASS-B 3m 9170 SHF HORM_150809 HORIZONTAL            Detector : Peak            Project : 651612            Mode : 1</p>	<p>Site : 03CH11-HY            Condition : FCC CLASS-B 3m 9170 SHF HORM_150809 VERTICAL            Detector : Peak            Project : 651612            Mode : 1</p>

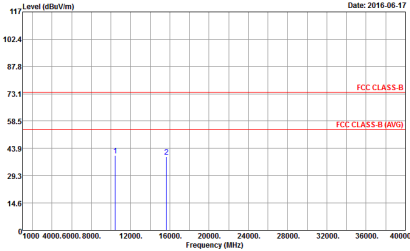
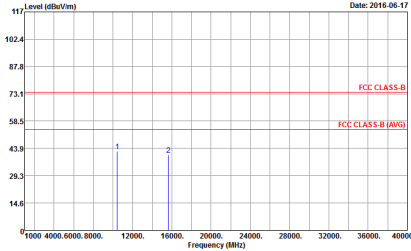

WIFI	Band 1 5150~5250MHz Harmonic @ 3m	
ANT	802.11a CH44 5220MHz	
1	Horizontal	Vertical
<p><b>Peak</b></p> <p><b>Avg.</b></p>	 <p>Date: 2016-06-17</p> <p>Site : 03CH11-HY            Condition : FCC CLASS-B 3m 9170 SHF HORN_150809 HORIZONTAL            Detector : Peak            Project : 651612            Mode : 2</p>	 <p>Date: 2016-06-17</p> <p>Site : 03CH11-HY            Condition : FCC CLASS-B 3m 9170 SHF HORN_150809 VERTICAL            Detector : Peak            Project : 651612            Mode : 2</p>

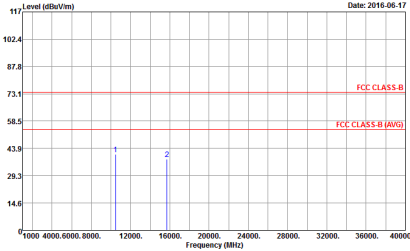
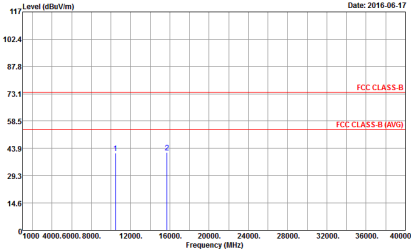

WIFI	Band 1 5150~5250MHz Harmonic @ 3m	
ANT	802.11a CH48 5240MHz	
1	Horizontal	Vertical
<p><b>Peak</b></p> <p><b>Avg.</b></p>	 <p>Date: 2016-06-17</p> <p>Site : 03CH11-HY            Condition : FCC CLASS-B 3m 9170 SHF HORN_150809 HORIZONTAL            Detector : Peak            Project : 651612            Mode : 3</p>	 <p>Date: 2016-06-17</p> <p>Site : 03CH11-HY            Condition : FCC CLASS-B 3m 9170 SHF HORN_150809 VERTICAL            Detector : Peak            Project : 651612            Mode : 3</p>



**Band 1 5150~5250MHz  
WIFI 802.11n HT20 (Harmonic @ 3m)**

WIFI	Band 1 5150~5250MHz Harmonic @ 3m	
ANT	802.11n HT20 CH36 5180MHz	
1	Horizontal	Vertical
<p><b>Peak</b> <b>Avg.</b></p>	<p>Date: 2016-06-17</p> <p>Site : 03CH11-HY Condition : FCC CLASS-B 3m 9170 SHF HORM_150809 HORIZONTAL Detector : Peak Project : 651612 Mode : 10</p>	<p>Date: 2016-06-17</p> <p>Site : 03CH11-HY Condition : FCC CLASS-B 3m 9170 SHF HORM_150809 VERTICAL Detector : Peak Project : 651612 Mode : 10</p>

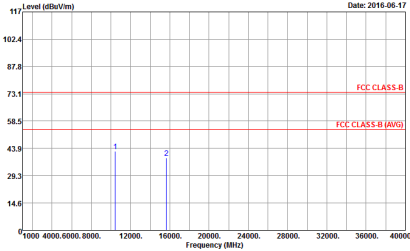
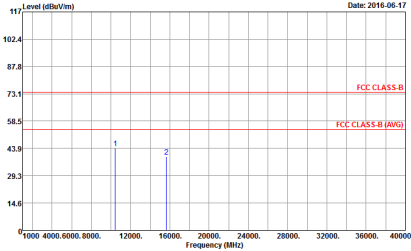

WIFI	Band 1 5150~5250MHz Harmonic @ 3m	
ANT	802.11n HT20 CH44 5220MHz	
1	Horizontal	Vertical
<p><b>Peak</b></p> <p><b>Avg.</b></p>	 <p>Date: 2016-06-17</p> <p>Site : 03CH11-HY            Condition : FCC CLASS-B 3m 9170 SHF HORN_150809 HORIZONTAL            Detector : Peak            Project : 651612            Mode : II</p>	 <p>Date: 2016-06-17</p> <p>Site : 03CH11-HY            Condition : FCC CLASS-B 3m 9170 SHF HORN_150809 VERTICAL            Detector : Peak            Project : 651612            Mode : II</p>

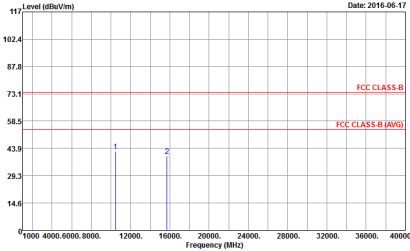
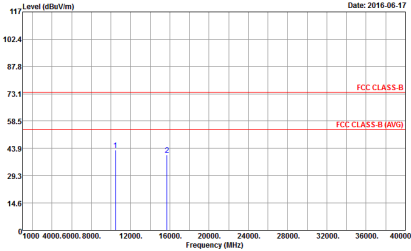

WIFI	Band 1 5150~5250MHz Harmonic @ 3m	
ANT	802.11n HT20 CH48 5240MHz	
1	Horizontal	Vertical
<p><b>Peak</b></p> <p><b>Avg.</b></p>	 <p>Site : 03CH11-HY          Condition : FCC CLASS-B 3m 9170 SHF HORM_150809 HORIZONTAL          Detector : Peak          Project : 651612          Mode : 12</p>	 <p>Site : 03CH11-HY          Condition : FCC CLASS-B 3m 9170 SHF HORM_150809 VERTICAL          Detector : Peak          Project : 651612          Mode : 12</p>

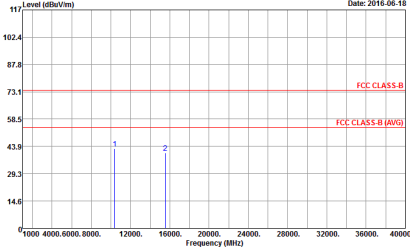
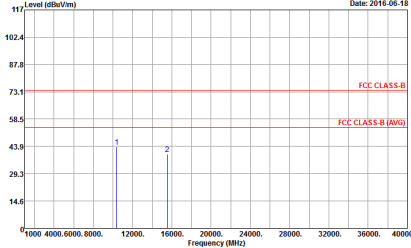

**Band 1 5150~5250MHz**  
**WIFI 802.11n HT40 (Harmonic @ 3m)**

WIFI	Band 1 5150~5250MHz Harmonic @ 3m	
ANT	802.11n HT40 CH38 5190MHz	
1	Horizontal	Vertical
<p><b>Peak</b></p> <p><b>Avg.</b></p>	 <p>Site : 03CH11-HY            Condition : FCC CLASS-B 3m 9170 SHF HORM_150809 HORIZONTAL            Detector : Peak            Project : 651612            Mode : 19</p>	 <p>Site : 03CH11-HY            Condition : FCC CLASS-B 3m 9170 SHF HORM_150809 VERTICAL            Detector : Peak            Project : 651612            Mode : 19</p>

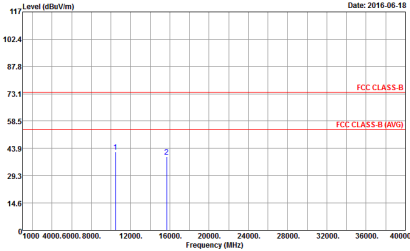
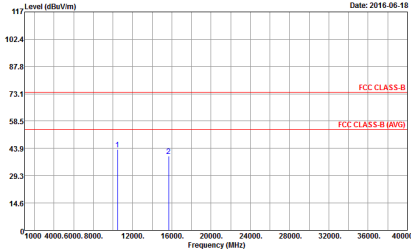

WIFI	Band 1 5150~5250MHz Harmonic @ 3m	
ANT	802.11n HT40 CH46 5230MHz	
1	Horizontal	Vertical
<p><b>Peak</b></p> <p><b>Avg.</b></p>	 <p>Site : 03CH11-HY            Condition : FCC CLASS-B 3m 9170 SHF HORN_150809 HORIZONTAL            Detector : Peak            Project : 651612            Mode : 20</p>	 <p>Site : 03CH11-HY            Condition : FCC CLASS-B 3m 9170 SHF HORN_150809 VERTICAL            Detector : Peak            Project : 651612            Mode : 20</p>



**Band 2 - 5250~5350MHz**  
**WIFI 802.11a (Band Edge @ 3m)**

WIFI	Band 2 5250~5350MHz Band Edge @ 3m	
ANT	802.11a CH52 5260MHz - L	
1	<b>Horizontal</b>	<b>Fundamental</b>
<b>Peak</b>	<p>Site : 03CH11-HY            Condition : FCC CLASS-B 3m HORN 9120D-HF HORIZONTAL            RBW:1000.000KHz VBW:3000.000KHz SWT:Auto            Detector : Peak            Project : 651612            Mode : 4</p>	<p>Site : 03CH11-HY            Condition : FCC CLASS-B 3m HORN 9120D-HF HORIZONTAL            RBW:1000.000KHz VBW:3000.000KHz SWT:Auto            Detector : Peak            Project : 651612            Mode : 4</p>
<b>Avg.</b>	<p>Site : 03CH11-HY            Condition : FCC CLASS-B (AVG) 3m HORN 9120D-HF HORIZONTAL            RBW:1000.000KHz VBW:1.000KHz SWT:Auto            Detector : Peak            Project : 651612            Mode : 4</p>	<b>Left blank</b>

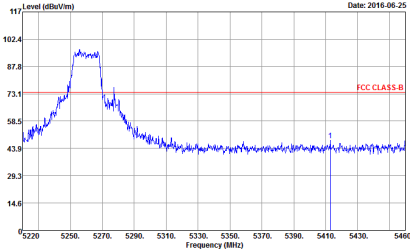
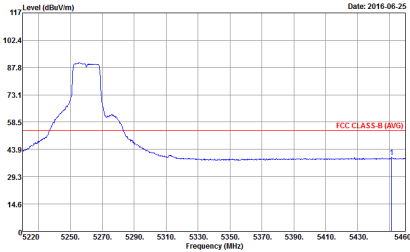

WIFI	Band 2 5250~5350MHz Band Edge @ 3m	
ANT	802.11a CH52 5260MHz - R	
1	Horizontal	Fundamental
Peak	 <p>Site : 03CH11-HY            Condition : FCC CLASS-B 3m HORN 9120D-HF HORIZONTAL            RBW:1000.000KHz VBW:3000.000KHz SWT:Auto            Detector : Peak            Project : 651612            Mode : 4</p>	Left blank
Avg.	 <p>Site : 03CH11-HY            Condition : FCC CLASS-B (AVG) 3m HORN 9120D-HF HORIZONTAL            RBW:1000.000KHz VBW:1000KHz SWT:Auto            Detector : Peak            Project : 651612            Mode : 4</p>	Left blank

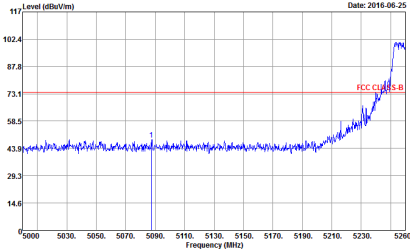
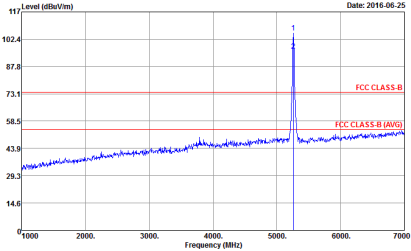
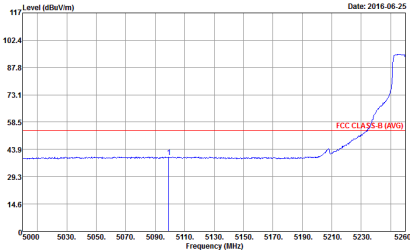

WIFI	Band 2 5250~5350MHz Band Edge @ 3m	
ANT	802.11a CH52 5260MHz - L	
1	Vertical	Fundamental
Peak	 <p>Date: 2016-06-25</p> <p>Site : 03CH11-HY            Condition : FCC CLASS-B 3m HORN 9120D-HF VERTICAL            RBW:1000.000KHz VBW:3000.000KHz SWT:Auto            Detector : Peak            Project : 651612            Mode : 4</p>	 <p>Date: 2016-06-25</p> <p>Site : 03CH11-HY            Condition : FCC CLASS-B 3m HORN 9120D-HF VERTICAL            RBW:1000.000KHz VBW:3000.000KHz SWT:Auto            Detector : Peak            Project : 651612            Mode : 4</p>
Avg.	 <p>Date: 2016-06-25</p> <p>Site : 03CH11-HY            Condition : FCC CLASS-B (AVG) 3m HORN 9120D-HF VERTICAL            RBW:1000.000KHz VBW:1000KHz SWT:Auto            Detector : Peak            Project : 651612            Mode : 4</p>	Left blank

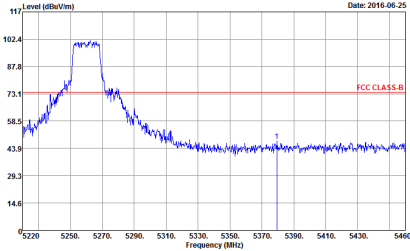
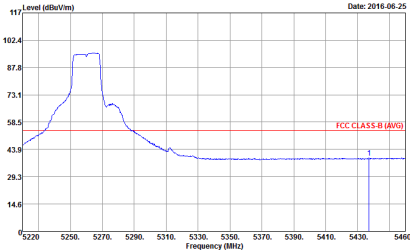

WIFI	Band 2 5250~5350MHz Band Edge @ 3m	
ANT	802.11a CH52 5260MHz - R	
1	Vertical	Fundamental
Peak	 <p>           Site : 03CH11-HY            Condition : FCC CLASS-B 3m HORN 9120D-HF VERTICAL            RBW:1000.000KHz VBW:3000.000KHz SWT:Auto            Detector : Peak            Project : 651612            Mode : 4         </p>	Left blank
Avg.	 <p>           Site : 03CH11-HY            Condition : FCC CLASS-B (AVG) 3m HORN 9120D-HF VERTICAL            RBW:1000.000KHz VBW:1000KHz SWT:Auto            Detector : Peak            Project : 651612            Mode : 4         </p>	Left blank

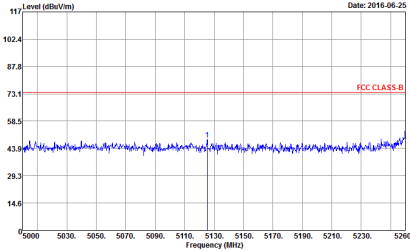
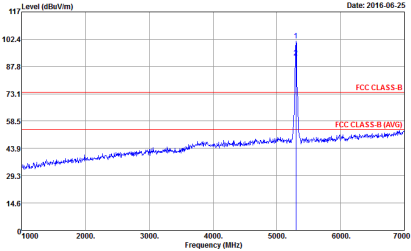
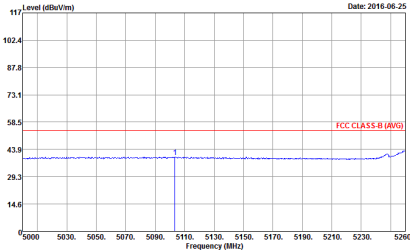

WIFI	Band 2 5250~5350MHz Band Edge @ 3m	
ANT	802.11a CH60 5300MHz - L	
1	Horizontal	Fundamental
Peak	 <p>Date: 2016-06-25</p> <p>Site : 03CH11-HY            Condition : FCC CLASS-B 3m HORN 9120D-HF HORIZONTAL            RBW:1000.000KHz VBW:3000.000KHz SWT:Auto            Detector : Peak            Project : 651612            Mode : 5</p>	 <p>Date: 2016-06-25</p> <p>Site : 03CH11-HY            Condition : FCC CLASS-B 3m HORN 9120D-HF HORIZONTAL            RBW:1000.000KHz VBW:3000.000KHz SWT:Auto            Detector : Peak            Project : 651612            Mode : 5</p>
Avg.	 <p>Date: 2016-06-25</p> <p>Site : 03CH11-HY            Condition : FCC CLASS-B (AVG) 3m HORN 9120D-HF HORIZONTAL            RBW:1000.000KHz VBW:1000KHz SWT:Auto            Detector : Peak            Project : 651612            Mode : 5</p>	Left blank

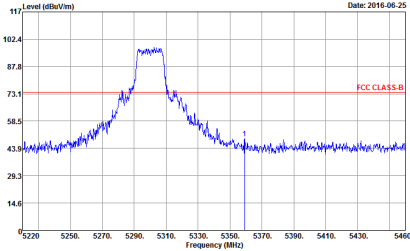
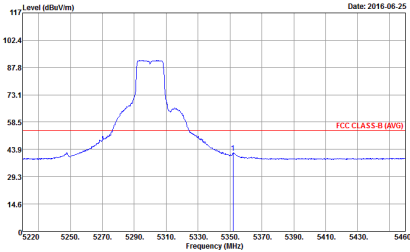

WIFI	Band 2 5250~5350MHz Band Edge @ 3m	
ANT	802.11a CH60 5300MHz - R	
1	Horizontal	Fundamental
Peak	 <p>Date: 2016-06-25</p> <p>Site : 03CH11-HY  Condition : FCC CLASS-B 3m HORN 9120D-HF HORIZONTAL  RBW:1000.000KHz VBW:3000.000KHz SWT:Auto  Detector : Peak  Project : 651612  Mode : 5</p>	Left blank
Avg.	 <p>Date: 2016-06-25</p> <p>Site : 03CH11-HY  Condition : FCC CLASS-B (AVG) 3m HORN 9120D-HF HORIZONTAL  RBW:1000.000KHz VBW:1000KHz SWT:Auto  Detector : Peak  Project : 651612  Mode : 5</p>	Left blank

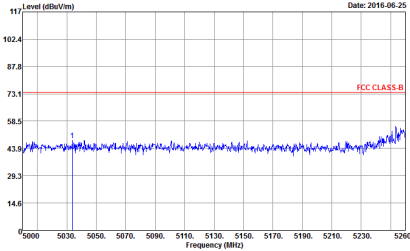
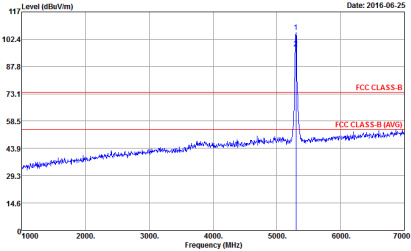
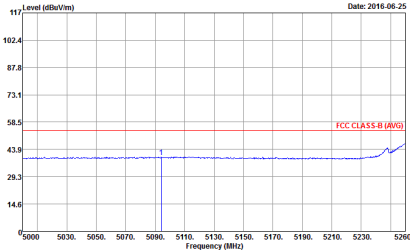

WIFI	Band 2 5250~5350MHz Band Edge @ 3m	
ANT	802.11a CH60 5300MHz - L	
1	Vertical	Fundamental
Peak	 <p>Date: 2016-06-25</p> <p>Site : 03CH11-HY            Condition : FCC CLASS-B 3m HORN 9120D-HF VERTICAL            RBW:1000.000KHz VBW:3000.000KHz SWT:Auto            Detector : Peak            Project : 651612            Mode : 5</p>	 <p>Date: 2016-06-25</p> <p>Site : 03CH11-HY            Condition : FCC CLASS-B 3m HORN 9120D-HF VERTICAL            RBW:1000.000KHz VBW:3000.000KHz SWT:Auto            Detector : Peak            Project : 651612            Mode : 5</p>
Avg.	 <p>Date: 2016-06-25</p> <p>Site : 03CH11-HY            Condition : FCC CLASS-B (AVG) 3m HORN 9120D-HF VERTICAL            RBW:1000.000KHz VBW:1000KHz SWT:Auto            Detector : Peak            Project : 651612            Mode : 5</p>	Left blank

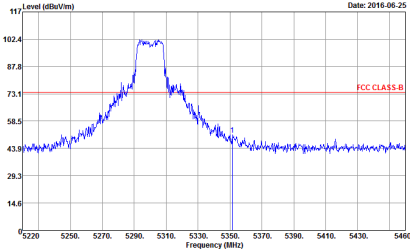
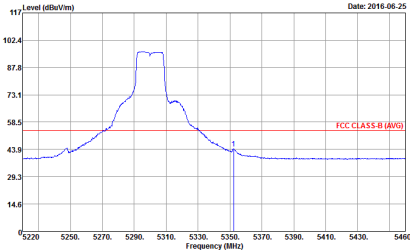

WIFI	Band 2 5250~5350MHz Band Edge @ 3m	
ANT	802.11a CH60 5300MHz - R	
1	Vertical	Fundamental
Peak	 <p>           Site : 03CH11-HY            Condition : FCC CLASS-B 3m HORN 9120D-HF VERTICAL            RBW:1000.000KHz VBW:3000.000KHz SWT:Auto            Detector : Peak            Project : 651612            Mode : 5         </p>	Left blank
Avg.	 <p>           Site : 03CH11-HY            Condition : FCC CLASS-B (AVG) 3m HORN 9120D-HF VERTICAL            RBW:1000.000KHz VBW:1000KHz SWT:Auto            Detector : Peak            Project : 651612            Mode : 5         </p>	Left blank

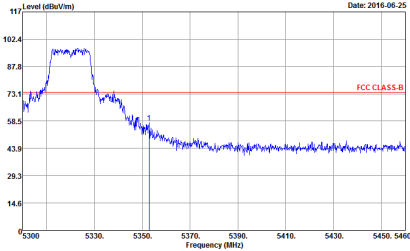
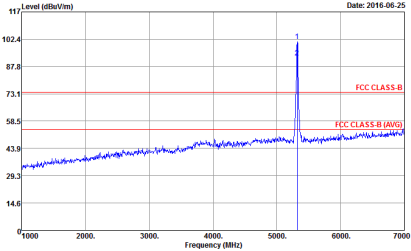
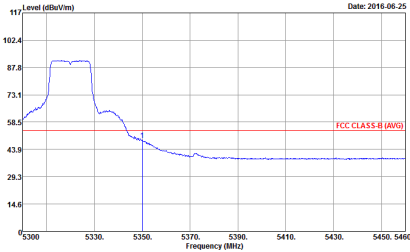

WIFI	Band 2 5250~5350MHz Band Edge @ 3m	
ANT	802.11a CH64 5320MHz	
1	Horizontal	Fundamental
Peak	 <p>Date: 2016-06-25</p> <p>Site : 03CH11-HY  Condition : FCC CLASS-B 3m HORN 9120D-HF HORIZONTAL  RBW:1000.000KHz VBW:3000.000KHz SWT:Auto  Detector : Peak  Project : 651612  Mode : 6</p>	 <p>Date: 2016-06-25</p> <p>Site : 03CH11-HY  Condition : FCC CLASS-B 3m HORN 9120D-HF HORIZONTAL  RBW:1000.000KHz VBW:3000.000KHz SWT:Auto  Detector : Peak  Project : 651612  Mode : 6</p>
Avg.	 <p>Date: 2016-06-25</p> <p>Site : 03CH11-HY  Condition : FCC CLASS-B (AVG) 3m HORN 9120D-HF HORIZONTAL  RBW:1000.000KHz VBW:1000KHz SWT:Auto  Detector : Peak  Project : 651612  Mode : 6</p>	Left blank

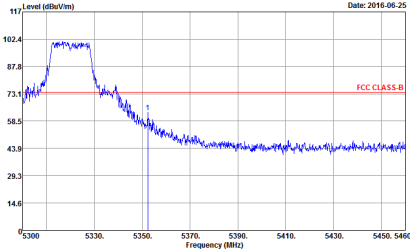
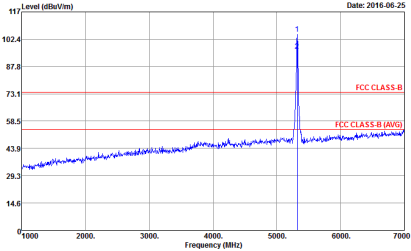
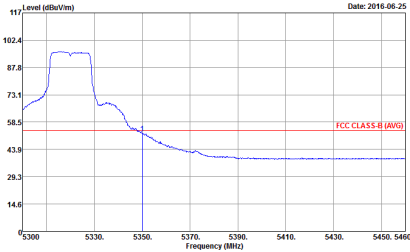

WIFI	Band 2 5250~5350MHz Band Edge @ 3m	
ANT	802.11a CH64 5320MHz	
1	Vertical	Fundamental
Peak	 <p>Date: 2016-06-25</p> <p>Site : 03CH11-HY            Condition : FCC CLASS-B 3m HORN 9120D-HF VERTICAL            RBW:1000.000KHz VBW:3000.000KHz SWT:Auto            Detector : Peak            Project : 651612            Mode : 6</p>	 <p>Date: 2016-06-25</p> <p>Site : 03CH11-HY            Condition : FCC CLASS-B 3m HORN 9120D-HF VERTICAL            RBW:1000.000KHz VBW:3000.000KHz SWT:Auto            Detector : Peak            Project : 651612            Mode : 6</p>
Avg.	 <p>Date: 2016-06-25</p> <p>Site : 03CH11-HY            Condition : FCC CLASS-B (AVG) 3m HORN 9120D-HF VERTICAL            RBW:1000.000KHz VBW:1000KHz SWT:Auto            Detector : Peak            Project : 651612            Mode : 6</p>	Left blank

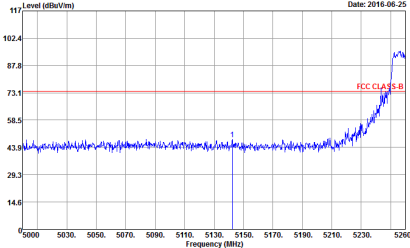
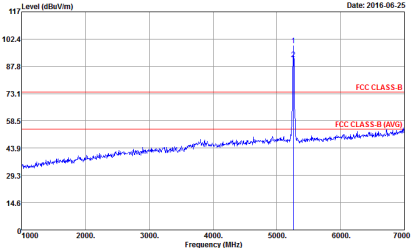
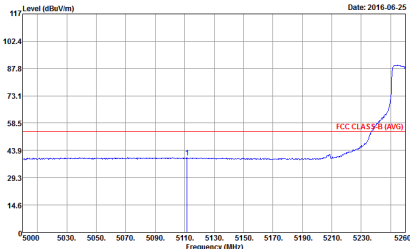

**Band 2 5250~5350MHz  
WIFI 802.11n HT20 (Band Edge @ 3m)**

WIFI	Band 2 5250~5350MHz Band Edge @ 3m	
ANT	802.11n HT20 CH52 5260MHz - L	
1	Horizontal	Fundamental
<p><b>Peak</b></p>	 <p>Date: 2016-06-25</p> <p>Site : 03CH11-HY Condition : FCC CLASS-B 3m HORN 9120D-HF HORIZONTAL RBW:1000.000KHz VBW:3000.000KHz SWT:Auto Detector : Peak Project : 651612 Mode : 13</p>	 <p>Date: 2016-06-25</p> <p>Site : 03CH11-HY Condition : FCC CLASS-B 3m HORN 9120D-HF HORIZONTAL RBW:1000.000KHz VBW:3000.000KHz SWT:Auto Detector : Peak Project : 651612 Mode : 13</p>
<p><b>Avg.</b></p>	 <p>Date: 2016-06-25</p> <p>Site : 03CH11-HY Condition : FCC CLASS-B (AVG) 3m HORN 9120D-HF HORIZONTAL RBW:1000.000KHz VBW:1.000KHz SWT:Auto Detector : Peak Project : 651612 Mode : 13</p>	<p>Left blank</p>

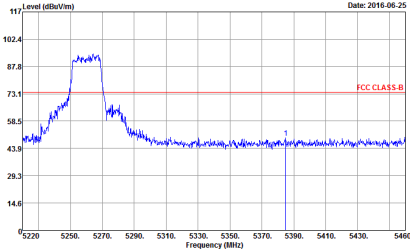
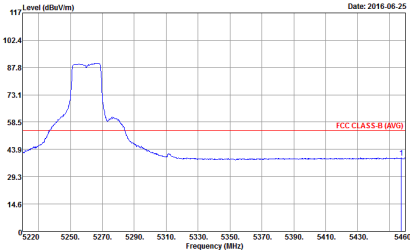

WIFI	Band 2 5250~5350MHz Band Edge @ 3m	
ANT	802.11n HT20 CH52 5260MHz - R	
1	Horizontal	Fundamental
Peak	 <p>Site : 03CH11-HY            Condition : FCC CLASS-B 3m HORN 9120D-HF HORIZONTAL            RBW:1000.000KHz VBW:3000.000KHz SWT:Auto            Detector : Peak            Project : 651612            Mode : 13</p>	Left blank
Avg.	 <p>Site : 03CH11-HY            Condition : FCC CLASS-B (AVG) 3m HORN 9120D-HF HORIZONTAL            RBW:1000.000KHz VBW:1000KHz SWT:Auto            Detector : Peak            Project : 651612            Mode : 13</p>	Left blank

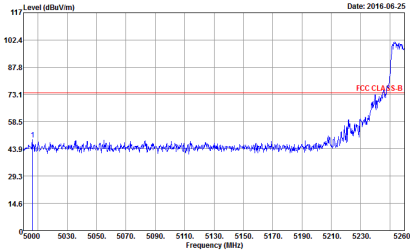
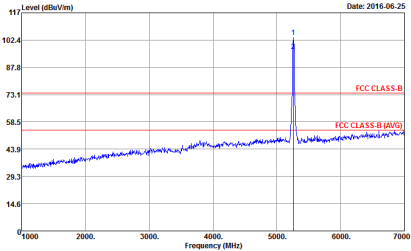
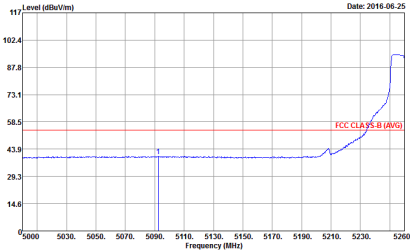

WIFI	Band 2 5250~5350MHz Band Edge @ 3m	
ANT	802.11n HT20 CH52 5260MHz - L	
1	Vertical	Fundamental
Peak	 <p>Date: 2016-06-25</p> <p>Site : 03CH11-HY            Condition : FCC CLASS-B 3m HORN 9120D-HF VERTICAL            RBW:1000.000KHz VBW:3000.000KHz SWT:Auto            Detector : Peak            Project : 651612            Mode : 13</p>	 <p>Date: 2016-06-25</p> <p>Site : 03CH11-HY            Condition : FCC CLASS-B 3m HORN 9120D-HF VERTICAL            RBW:1000.000KHz VBW:3000.000KHz SWT:Auto            Detector : Peak            Project : 651612            Mode : 13</p>
Avg.	 <p>Date: 2016-06-25</p> <p>Site : 03CH11-HY            Condition : FCC CLASS-B (AVG) 3m HORN 9120D-HF VERTICAL            RBW:1000.000KHz VBW:1000KHz SWT:Auto            Detector : Peak            Project : 651612            Mode : 13</p>	Left blank

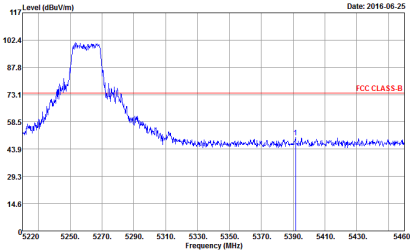
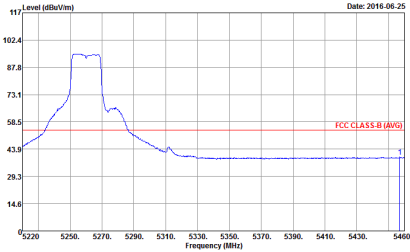

WIFI	Band 2 5250~5350MHz Band Edge @ 3m	
ANT	802.11n HT20 CH52 5260MHz - R	
1	Vertical	Fundamental
Peak	 <p>Site : 03CH11-HY            Condition : FCC CLASS-B 3m HORN 9120D-HF VERTICAL            RBW:1000.000KHz VBW:3000.000KHz SWT:Auto            Detector : Peak            Project : 651612            Mode : 13</p>	Left blank
Avg.	 <p>Site : 03CH11-HY            Condition : FCC CLASS-B (AVG) 3m HORN 9120D-HF VERTICAL            RBW:1000.000KHz VBW:1000KHz SWT:Auto            Detector : Peak            Project : 651612            Mode : 13</p>	Left blank

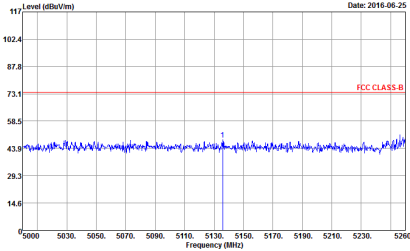
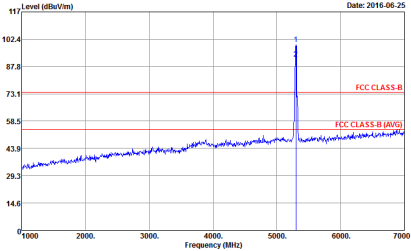
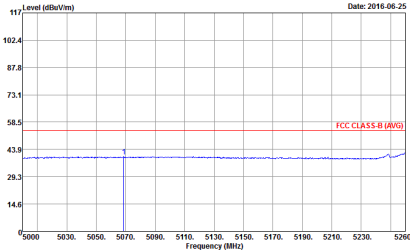

WIFI	Band 2 5250~5350MHz Band Edge @ 3m	
ANT	802.11n HT20 CH60 5300MHz - L	
1	Horizontal	Fundamental
Peak	 <p>Date: 2016-06-25</p> <p>Site : 03CH11-HY  Condition : FCC CLASS-B 3m HORN 9120D-HF HORIZONTAL  RBW:1000.000KHz VBW:3000.000KHz SWT:Auto  Detector : Peak  Project : 651612  Mode : 14</p>	 <p>Date: 2016-06-25</p> <p>Site : 03CH11-HY  Condition : FCC CLASS-B 3m HORN 9120D-HF HORIZONTAL  RBW:1000.000KHz VBW:3000.000KHz SWT:Auto  Detector : Peak  Project : 651612  Mode : 14</p>
Avg.	 <p>Date: 2016-06-25</p> <p>Site : 03CH11-HY  Condition : FCC CLASS-B (AVG) 3m HORN 9120D-HF HORIZONTAL  RBW:1000.000KHz VBW:1000KHz SWT:Auto  Detector : Peak  Project : 651612  Mode : 14</p>	Left blank



WIFI	Band 2 5250~5350MHz Band Edge @ 3m	
ANT	802.11n HT20 CH60 5300MHz - R	
1	Horizontal	Vertical
Peak	<p>Date: 2016-06-25</p> <p>Site : 03CH11-HY  Condition : FCC CLASS-B 3m HORN 9120D-HF HORIZONTAL  Detector : Peak  Project : 651612  Mode : 14</p>	Left blank
Avg.	<p>Date: 2016-06-25</p> <p>Site : 03CH11-HY  Condition : FCC CLASS-B (AVG) 3m HORN 9120D-HF HORIZONTAL  Detector : Peak  Project : 651612  Mode : 14</p>	Left blank

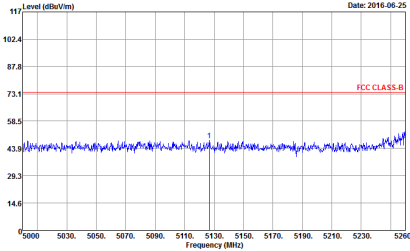
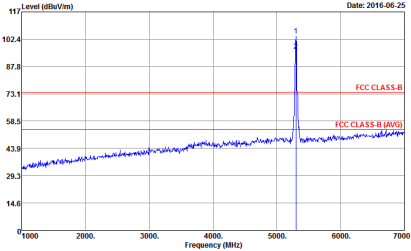
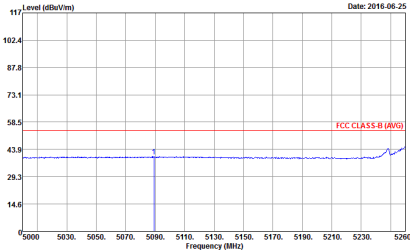

WIFI	Band 2 5250~5350MHz Band Edge @ 3m	
ANT	802.11n HT20 CH60 5300MHz - L	
1	Vertical	Fundamental
Peak	 <p>Date: 2016-06-25</p> <p>Site : 03CH11-HY            Condition : FCC CLASS-B 3m HORN 9120D-HF VERTICAL            RBW:1000.000KHz VBW:3000.000KHz SWT:Auto            Detector : Peak            Project : 651612            Mode : 14</p>	 <p>Date: 2016-06-25</p> <p>Site : 03CH11-HY            Condition : FCC CLASS-B 3m HORN 9120D-HF VERTICAL            RBW:1000.000KHz VBW:3000.000KHz SWT:Auto            Detector : Peak            Project : 651612            Mode : 14</p>
Avg.	 <p>Date: 2016-06-25</p> <p>Site : 03CH11-HY            Condition : FCC CLASS-B (AVG) 3m HORN 9120D-HF VERTICAL            RBW:1000.000KHz VBW:1000KHz SWT:Auto            Detector : Peak            Project : 651612            Mode : 14</p>	Left blank

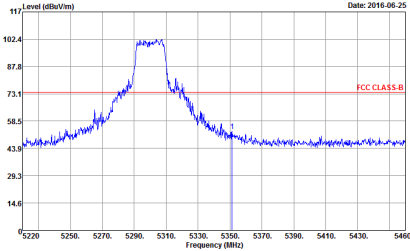
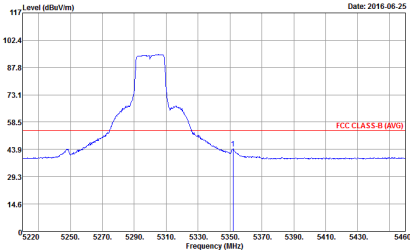

WIFI	Band 2 5250~5350MHz Band Edge @ 3m	
ANT	802.11n HT20 CH60 5300MHz - R	
1	Vertical	Fundamental
Peak	 <p>Site : 03CH11-HY  Condition : FCC CLASS-B 3m HORN 9120D-HF VERTICAL  RBW:1000.000KHz VBW:3000.000KHz SWT:Auto  Detector : Peak  Project : 651612  Mode : 14</p>	Left blank
Avg.	 <p>Site : 03CH11-HY  Condition : FCC CLASS-B (AVG) 3m HORN 9120D-HF VERTICAL  RBW:1000.000KHz VBW:1000KHz SWT:Auto  Detector : Peak  Project : 651612  Mode : 14</p>	Left blank

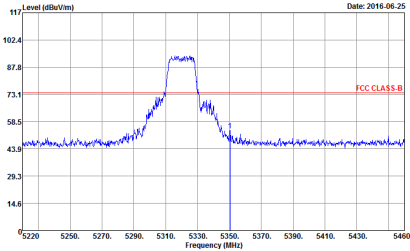
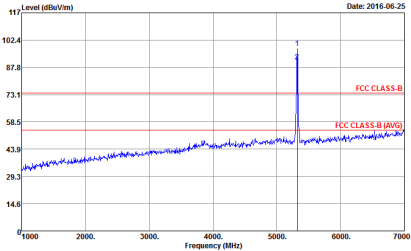
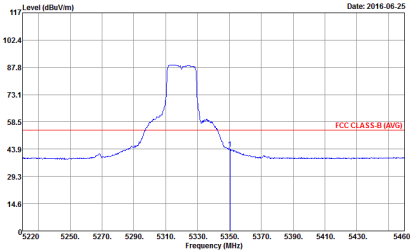

WIFI	Band 2 5250~5350MHz Band Edge @ 3m	
ANT	802.11n HT20 CH64 5320MHz	
1	Horizontal	Fundamental
Peak	 <p>Date: 2016-06-25</p> <p>Site : 03CH11-HY            Condition : FCC CLASS-B 3m HORN 9120D-HF HORIZONTAL            RBW:1000.000KHz VBW:3000.000KHz SWT:Auto            Detector : Peak            Project : 651612            Mode : 15</p>	 <p>Date: 2016-06-25</p> <p>Site : 03CH11-HY            Condition : FCC CLASS-B 3m HORN 9120D-HF HORIZONTAL            RBW:1000.000KHz VBW:3000.000KHz SWT:Auto            Detector : Peak            Project : 651612            Mode : 15</p>
Avg.	 <p>Date: 2016-06-25</p> <p>Site : 03CH11-HY            Condition : FCC CLASS-B (AVG) 3m HORN 9120D-HF HORIZONTAL            RBW:1000.000KHz VBW:1000KHz SWT:Auto            Detector : Peak            Project : 651612            Mode : 15</p>	Left blank

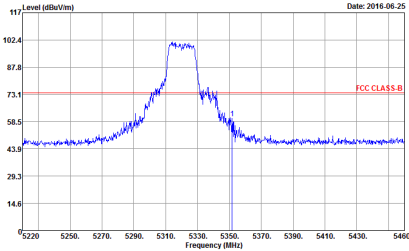
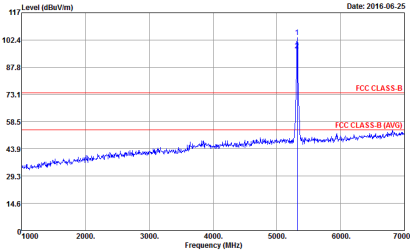
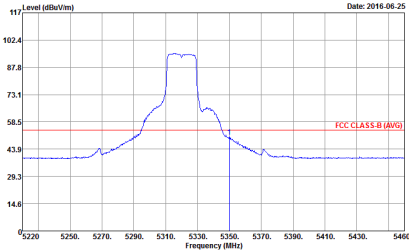

WIFI	Band 2 5250~5350MHz Band Edge @ 3m	
ANT	802.11n HT20 CH64 5320MHz	
1	Vertical	Fundamental
Peak	 <p>Site : 03CH11-HY            Condition : FCC CLASS-B 3m HORN 9120D-HF VERTICAL            RBW:1000.000KHz VBW:3000.000KHz SWT:Auto            Detector : Peak            Project : 651612            Mode : 15</p>	 <p>Site : 03CH11-HY            Condition : FCC CLASS-B 3m HORN 9120D-HF VERTICAL            RBW:1000.000KHz VBW:3000.000KHz SWT:Auto            Detector : Peak            Project : 651612            Mode : 15</p>
Avg.	 <p>Site : 03CH11-HY            Condition : FCC CLASS-B (AVG) 3m HORN 9120D-HF VERTICAL            RBW:1000.000KHz VBW:1000KHz SWT:Auto            Detector : Peak            Project : 651612            Mode : 15</p>	Left blank



**Band 2 5250~5350MHz  
WIFI 802.11n HT40 (Band Edge @ 3m)**

WIFI	Band 2 5250~5350MHz Band Edge @ 3m	
ANT	802.11n HT40 CH54 5270 - L	
1	Horizontal	Fundamental
<p><b>Peak</b></p>	<p>Date: 2016-06-25</p> <p>Site : 03CH11-HY Condition : FCC CLASS-B 3m HORN 9120D-HF HORIZONTAL RBW:1000.000KHz VBW:3000.000KHz SWT:Auto Detector : Peak Project : 651612 Mode : Z1</p>	<p>Date: 2016-06-25</p> <p>Site : 03CH11-HY Condition : FCC CLASS-B 3m HORN 9120D-HF HORIZONTAL RBW:1000.000KHz VBW:3000.000KHz SWT:Auto Detector : Peak Project : 651612 Mode : Z1</p>
<p><b>Avg.</b></p>	<p>Date: 2016-06-25</p> <p>Site : 03CH11-HY Condition : FCC CLASS-B (AVG) 3m HORN 9120D-HF HORIZONTAL RBW:1000.000KHz VBW:3.000KHz SWT:Auto Detector : Peak Project : 651612 Mode : Z1</p>	<p>Left blank</p>

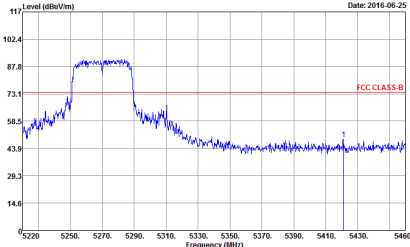
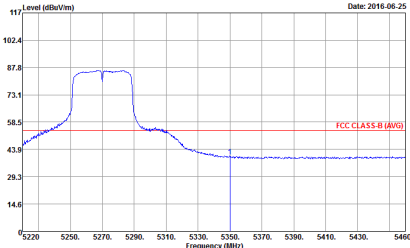

WIFI	Band 2 5250~5350MHz Band Edge @ 3m	
ANT	802.11n HT40 CH54 5270 - R	
1	Horizontal	Fundamental
Peak	 <p>Site : 03CH11-HY            Condition : FCC CLASS-B 3m HORN 9120D-HF HORIZONTAL            RBW:1000.000KHz VBW:3000.000KHz SWT:Auto            Detector : Peak            Project : 651612            Mode : Z1</p>	Left blank
Avg.	 <p>Site : 03CH11-HY            Condition : FCC CLASS-B (AVG) 3m HORN 9120D-HF HORIZONTAL            RBW:1000.000KHz VBW:3.000KHz SWT:Auto            Detector : Peak            Project : 651612            Mode : Z1</p>	Left blank

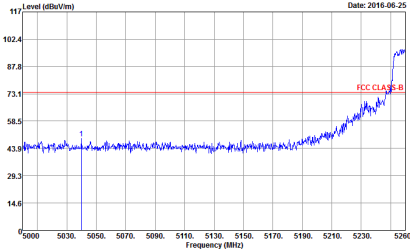
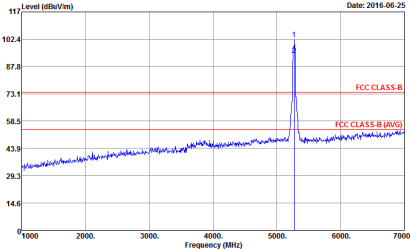
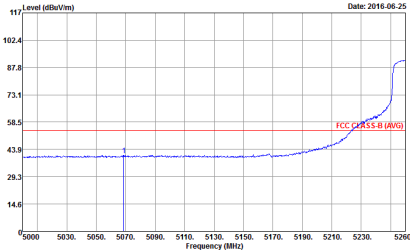

WIFI	Band 2 5250~5350MHz Band Edge @ 3m	
ANT	802.11n HT40 CH54 5270 - L	
1	Vertical	Vertical
Peak	 <p>Date: 2016-06-25</p> <p>Site : 03CH11-HY  Condition : FCC CLASS-B 3m HORN 9120D-HF VERTICAL  RBW:1000.000KHz VBW:3000.000KHz SWT:Auto  Detector : Peak  Project : 651612  Mode : Z1</p>	 <p>Date: 2016-06-25</p> <p>Site : 03CH11-HY  Condition : FCC CLASS-B 3m HORN 9120D-HF VERTICAL  RBW:1000.000KHz VBW:3000.000KHz SWT:Auto  Detector : Peak  Project : 651612  Mode : Z1</p>
Avg.	 <p>Date: 2016-06-25</p> <p>Site : 03CH11-HY  Condition : FCC CLASS-B (AVG) 3m HORN 9120D-HF VERTICAL  RBW:1000.000KHz VBW:3.000KHz SWT:Auto  Detector : Peak  Project : 651612  Mode : Z1</p>	Left blank

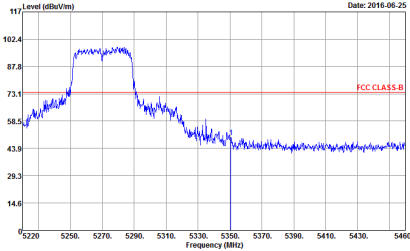
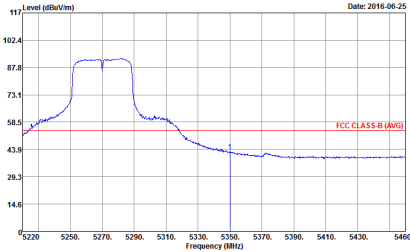

WIFI	Band 2 5250~5350MHz Band Edge @ 3m	
ANT	802.11n HT40 CH54 5270 - R	
1	Vertical	Vertical
Peak	 <p>Site : 03CH11-HY            Condition : FCC CLASS-B 3m HORN 9120D-HF VERTICAL            RBW:1000.000KHz VBW:3000.000KHz SWT:Auto            Detector : Peak            Project : 651612            Mode : Z1</p>	Left blank
Avg.	 <p>Site : 03CH11-HY            Condition : FCC CLASS-B (AVG) 3m HORN 9120D-HF VERTICAL            RBW:1000.000KHz VBW:3.000KHz SWT:Auto            Detector : Peak            Project : 651612            Mode : Z1</p>	Left blank

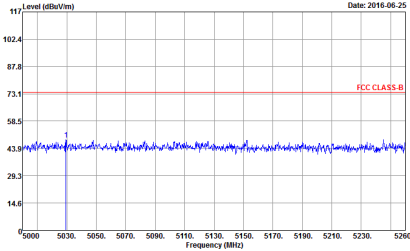
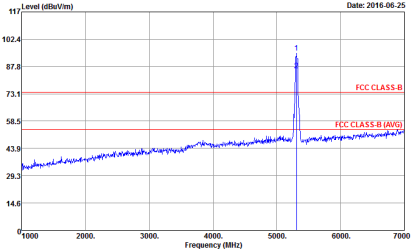
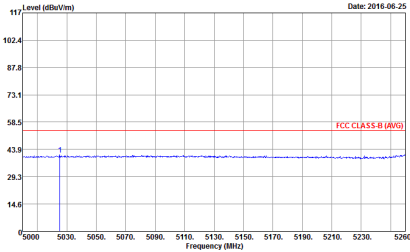

WIFI	Band 2 5250~5350MHz Band Edge @ 3m	
ANT	802.11n HT40 CH62 5310 - L	
1	Horizontal	Fundamental
Peak	 <p>Date: 2016-06-25</p> <p>Site : 03CH11-HY            Condition : FCC CLASS-B 3m HORN 9120D-HF HORIZONTAL            RBW:1000.000KHz VBW:3000.000KHz SWT:Auto            Detector : Peak            Project : 651612            Mode : 22            Setting : 13</p>	 <p>Date: 2016-06-25</p> <p>Site : 03CH11-HY            Condition : FCC CLASS-B 3m HORN 9120D-HF HORIZONTAL            RBW:1000.000KHz VBW:3000.000KHz SWT:Auto            Detector : Peak            Project : 651612            Mode : 22            Setting : 13</p>
Avg.	 <p>Date: 2016-06-25</p> <p>Site : 03CH11-HY            Condition : FCC CLASS-B (AVG) 3m HORN 9120D-HF HORIZONTAL            RBW:1000.000KHz VBW:3.000KHz SWT:Auto            Detector : Peak            Project : 651612            Mode : 22            Setting : 13</p>	Left blank

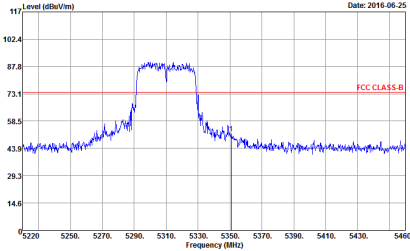
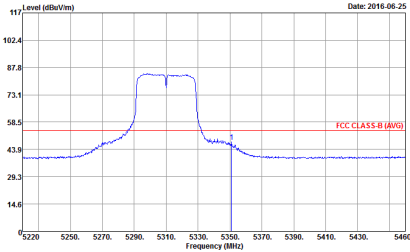

WIFI	Band 2 5250~5350MHz Band Edge @ 3m	
ANT	802.11n HT40 CH62 5310 - R	
1	Horizontal	Fundamental
Peak	 <p>Site : 03CH11-HY            Condition : FCC CLASS-B 3m HORN 9120D-HF HORIZONTAL            RBW:1000.000KHz VBW:3000.000KHz SWT:Auto            Detector : Peak            Project : 651612            Mode : 22            Setting : 13</p>	Left blank
Avg.	 <p>Site : 03CH11-HY            Condition : FCC CLASS-B (AVG) 3m HORN 9120D-HF HORIZONTAL            RBW:1000.000KHz VBW:3.000KHz SWT:Auto            Detector : Peak            Project : 651612            Mode : 22            Setting : 13</p>	Left blank

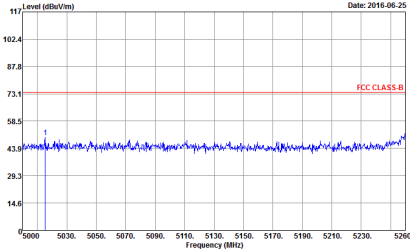
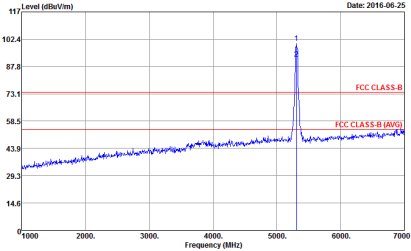
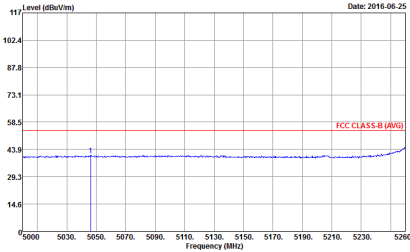

WIFI	Band 2 5250~5350MHz Band Edge @ 3m	
ANT	802.11n HT40 CH62 5310 - L	
1	Vertical	Fundamental
Peak	 <p>Date: 2016-06-25</p> <p>Site : 03CH11-HY            Condition : FCC CLASS-B 3m HORN 9120D-HF VERTICAL            RBW:1000.000KHz VBW:3000.000KHz SWT:Auto            Detector : Peak            Project : 651612            Mode : 22            Setting : 13</p>	 <p>Date: 2016-06-25</p> <p>Site : 03CH11-HY            Condition : FCC CLASS-B 3m HORN 9120D-HF VERTICAL            RBW:1000.000KHz VBW:3000.000KHz SWT:Auto            Detector : Peak            Project : 651612            Mode : 22            Setting : 13</p>
Avg.	 <p>Date: 2016-06-25</p> <p>Site : 03CH11-HY            Condition : FCC CLASS-B (AVG) 3m HORN 9120D-HF VERTICAL            RBW:1000.000KHz VBW:3.000KHz SWT:Auto            Detector : Peak            Project : 651612            Mode : 22            Setting : 13</p>	Left blank



WIFI	Band 2 5250~5350MHz Band Edge @ 3m	
ANT	802.11n HT40 CH62 5310 - R	
1	Vertical	Fundamental
Peak	<p>Site : 03CH11-HY Condition : FCC CLASS-B 3m HORN 9120D-HF VERTICAL RBW:1000.000KHz VBW:3000.000KHz SWT:Auto Detector : Peak Project : 651612 Mode : 22 Setting : 13</p>	Left blank
Avg.	<p>Site : 03CH11-HY Condition : FCC CLASS-B (AVG) 3m HORN 9120D-HF VERTICAL RBW:1000.000KHz VBW:3.000KHz SWT:Auto Detector : Peak Project : 651612 Mode : 22 Setting : 13</p>	Left blank



**Band 2 - 5250~5350MHz**  
**WIFI 802.11a (Harmonic @ 3m)**

WIFI	Band 2 5250~5350MHz Harmonic @ 3m	
ANT	802.11a CH52 5260MHz	
1	Horizontal	Vertical
<b>Peak</b> <b>Avg.</b>	<p>Site : 03CH11-HY Condition : FCC CLASS-B 3m 9170 SHF HORM_150809 HORIZONTAL Detector : Peak Project : 651612 Mode : 4</p>	<p>Site : 03CH11-HY Condition : FCC CLASS-B 3m 9170 SHF HORM_150809 VERTICAL Detector : Peak Project : 651612 Mode : 4</p>

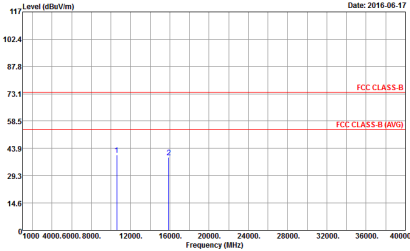
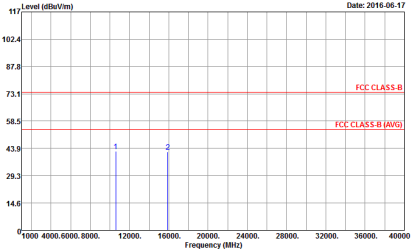

WIFI	Band 2 5250~5350MHz Harmonic @ 3m	
ANT	802.11a CH60 5300MHz	
1	Horizontal	Vertical
Peak Avg.	 <p>Site : 03CH11-HY Condition : FCC CLASS-B 3m 9170 SHF HORM_150809 HORIZONTAL Detector : Peak Project : 651612 Mode : 5</p>	 <p>Site : 03CH11-HY Condition : FCC CLASS-B 3m 9170 SHF HORM_150809 VERTICAL Detector : Peak Project : 651612 Mode : 5</p>

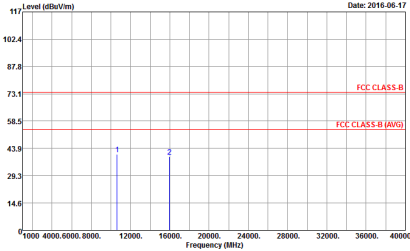
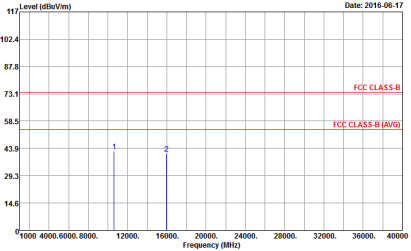

WIFI	Band 2 5250~5350MHz Harmonic @ 3m	
ANT	802.11a CH64 5320MHz	
1	Horizontal	Vertical
Peak Avg.	 <p>Site : 03CH11-HY Condition : FCC CLASS-B 3m 9170 SHF HORM_150809 HORIZONTAL Detector : Peak Project : 651612 Mode : 6</p>	 <p>Site : 03CH11-HY Condition : FCC CLASS-B 3m 9170 SHF HORM_150809 VERTICAL Detector : Peak Project : 651612 Mode : 6</p>



Band 2 5250~5350MHz  
WIFI 802.11n HT20 (Harmonic @ 3m)

WIFI	Band 2 5250~5350MHz Harmonic @ 3m	
ANT	802.11n HT20 CH52 5260MHz	
1	Horizontal	Vertical
Peak Avg.	<p>Site : 03CH11-HY Condition : FCC CLASS-B 3m 9170 SHF HORM_150809 HORIZONTAL Detector : Peak Project : 651612 Mode : 13</p>	<p>Site : 03CH11-HY Condition : FCC CLASS-B 3m 9170 SHF HORM_150809 VERTICAL Detector : Peak Project : 651612 Mode : 13</p>



WIFI	Band 2 5250~5350MHz Harmonic @ 3m	
ANT	802.11n HT20 CH60 5300MHz	
1	Horizontal	Vertical
Peak Avg.	<p>Site : 03CH11-HY Condition : FCC CLASS-B 3m 9170 SHF HORM_150809 HORIZONTAL Detector : Peak Project : 651612 Mode : 14</p>	<p>Site : 03CH11-HY Condition : FCC CLASS-B 3m 9170 SHF HORM_150809 VERTICAL Detector : Peak Project : 651612 Mode : 14</p>

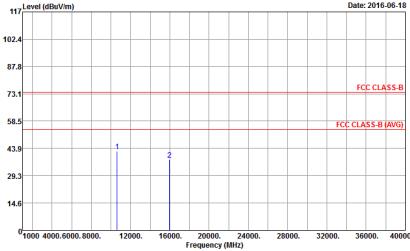
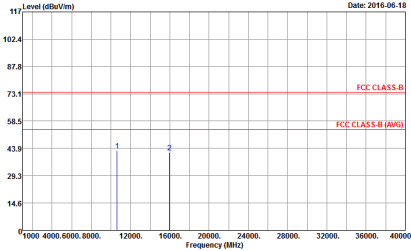

WIFI	Band 2 5250~5350MHz Harmonic @ 3m	
ANT	802.11n HT20 CH64 5320MHz	
1	Horizontal	Vertical
<p><b>Peak</b></p> <p><b>Avg.</b></p>	 <p>Site : 03CH11-HY            Condition : FCC CLASS-B 3m 9170 SHF HORN_150809 HORIZONTAL            Detector : Peak            Project : 651612            Mode : 15</p>	 <p>Site : 03CH11-HY            Condition : FCC CLASS-B 3m 9170 SHF HORN_150809 VERTICAL            Detector : Peak            Project : 651612            Mode : 15</p>

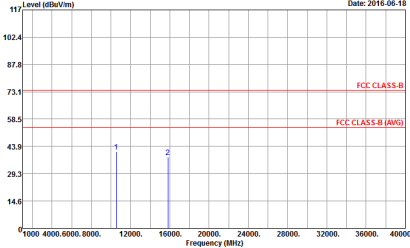
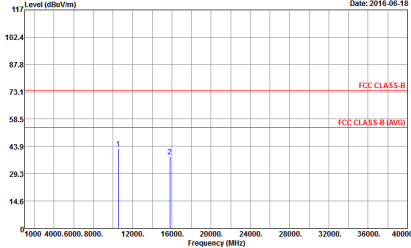

**Band 2 5250~5350MHz**  
**WIFI 802.11n HT40 (Harmonic @ 3m)**

WIFI	Band 2 5250~5350MHz Harmonic @ 3m	
ANT	802.11n HT40 CH54 5270	
1	Horizontal	Vertical
<p><b>Peak</b></p> <p><b>Avg.</b></p>	 <p>Date: 2016-06-18</p> <p>Site : 03CH11-HY            Condition : FCC CLASS-B 3m 9170 SHF HORM_150809 HORIZONTAL            Detector : Peak            Project : 651612            Mode : 21</p>	 <p>Date: 2016-06-18</p> <p>Site : 03CH11-HY            Condition : FCC CLASS-B 3m 9170 SHF HORM_150809 VERTICAL            Detector : Peak            Project : 651612            Mode : 21</p>

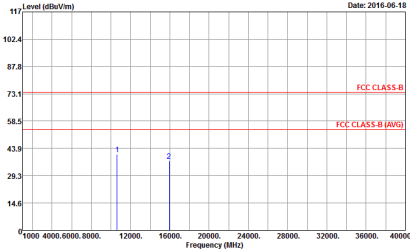
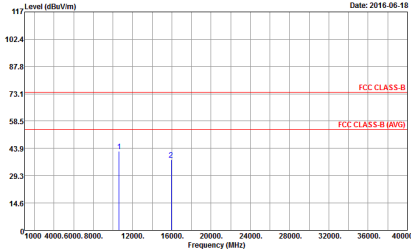

WIFI	Band 2 5250~5350MHz Harmonic @ 3m	
ANT	802.11n HT40 CH62 5310	
1	Horizontal	Vertical
<p><b>Peak</b></p> <p><b>Avg.</b></p>	 <p>Site : 03CH11-HY            Condition : FCC CLASS-B 3m 9170 SHF HORN_150809 HORIZONTAL            Detector : Peak            Project : 651612            Mode : Z2</p>	 <p>Site : 03CH11-HY            Condition : FCC CLASS-B 3m 9170 SHF HORN_150809 VERTICAL            Detector : Peak            Project : 651612            Mode : Z2</p>



**Band 3 - 5470~5725MHz**  
**WIFI 802.11a (Band Edge @ 3m)**

WIFI	Band 3 5470~5725MHz Band Edge @ 3m	
ANT	802.11a CH100 5500MHz	
<b>1</b>	<b>Horizontal</b>	<b>Fundamental</b>
<b>Peak</b>	<p>Site : 03CH11-HY            Condition : FCC PART15E 3m HORN 9120D-HF HORIZONTAL            RBW:1000.000KHz VBW:3000.000KHz SWT:Auto            Detector : Peak            Project : 651612            Mode : 7            : 68.3</p>	<p>Site : 03CH11-HY            Condition : FCC PART15E 3m HORN 9120D-HF HORIZONTAL            RBW:1000.000KHz VBW:3000.000KHz SWT:Auto            Detector : Peak            Project : 651612            Mode : 7            : 68.3</p>
<b>Avg.</b>	<p>Site : 03CH11-HY            Condition : FCC PART15E (AVG) 3m HORN 9120D-HF HORIZONTAL            RBW:1000.000KHz VBW:1000KHz SWT:Auto            Detector : Peak            Project : 651612            Mode : 7            : 68.3</p>	<b>Left blank</b>

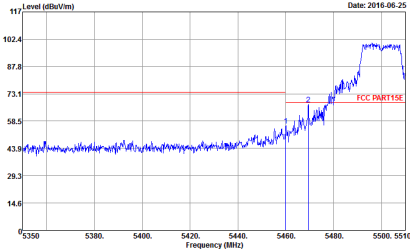
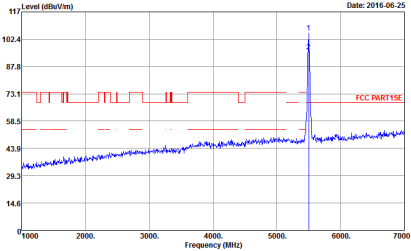
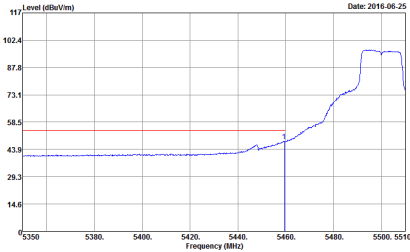

WIFI	Band 3 5470~5725MHz Band Edge @ 3m	
ANT	802.11a CH100 5500MHz	
1	Vertical	Fundamental
Peak	 <p>Date: 2016-06-25</p> <p>Site : 03CH11-HY            Condition : FCC PART15E 3m HORN 9120D-HF VERTICAL            RBW:1000.000KHz VBW:3000.000KHz SWT:Auto            Detector : Peak            Project : 651612            Mode : 7            : 68.3</p>	 <p>Date: 2016-06-25</p> <p>Site : 03CH11-HY            Condition : FCC PART15E 3m HORN 9120D-HF VERTICAL            RBW:1000.000KHz VBW:3000.000KHz SWT:Auto            Detector : Peak            Project : 651612            Mode : 7            : 68.3</p>
Avg.	 <p>Date: 2016-06-25</p> <p>Site : 03CH11-HY            Condition : FCC PART15E (AVG) 3m HORN 9120D-HF VERTICAL            RBW:1000.000KHz VBW:1000KHz SWT:Auto            Detector : Peak            Project : 651612            Mode : 7            : 68.3</p>	Left blank

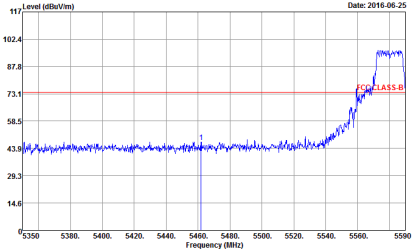
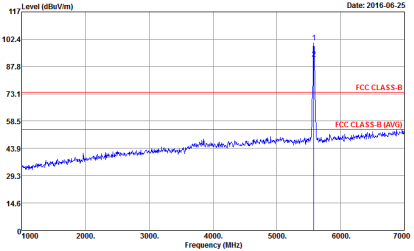
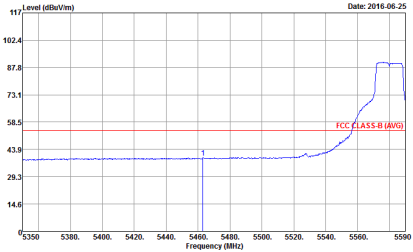

WIFI	Band 3 5470~5725MHz Band Edge @ 3m	
ANT	802.11a CH116 5580MHz - L	
1	Horizontal	Fundamental
Peak	 <p>Date: 2016-06-25</p> <p>Site : 03CH11-HY            Condition : FCC CLASS-B 3m HORN 9120D-HF HORIZONTAL            RBW:1000.000KHz VBW:3000.000KHz SWT:Auto            Detector : Peak            Project : 651612            Mode : 8</p>	 <p>Date: 2016-06-25</p> <p>Site : 03CH11-HY            Condition : FCC CLASS-B 3m HORN 9120D-HF HORIZONTAL            RBW:1000.000KHz VBW:3000.000KHz SWT:Auto            Detector : Peak            Project : 651612            Mode : 8</p>
Avg.	 <p>Date: 2016-06-25</p> <p>Site : 03CH11-HY            Condition : FCC CLASS-B (AVG) 3m HORN 9120D-HF HORIZONTAL            RBW:1000.000KHz VBW:1000KHz SWT:Auto            Detector : Peak            Project : 651612            Mode : 8</p>	Left blank



WIFI	Band 3 5470~5725MHz Band Edge @ 3m	
ANT	802.11a CH116 5580MHz - R	
1	Horizontal	Fundamental
Peak	<p>Site : 03CH11-HY            Condition : FCC CLASS-B 3m HORN 9120D-HF HORIZONTAL            RBW:1000.000KHz VBW:3000.000KHz SWT:Auto            Detector : Peak            Project : 651612            Mode : B</p>	Left blank
Avg.	<p>Site : 03CH11-HY            Condition : FCC CLASS-B (AVG) 3m HORN 9120D-HF HORIZONTAL            RBW:1000.000KHz VBW:1000KHz SWT:Auto            Detector : Peak            Project : 651612            Mode : B</p>	Left blank

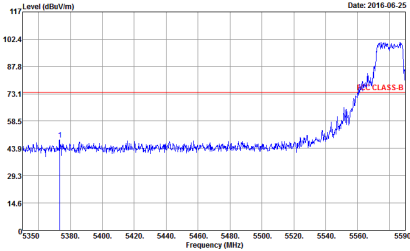
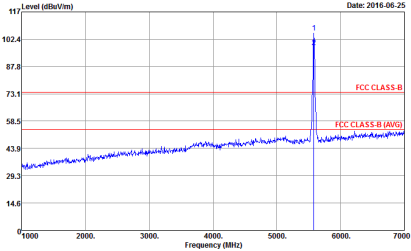
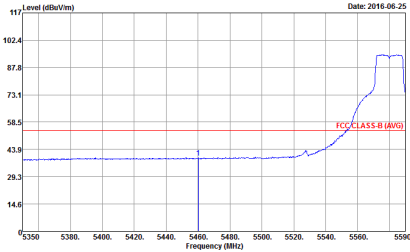

WIFI	Band 3 5470~5725MHz Band Edge @ 3m	
ANT	802.11a CH116 5580MHz - L	
1	Vertical	Fundamental
Peak	 <p>Date: 2016-06-25</p> <p>Site : 03CH11-HY            Condition : FCC CLASS-B 3m HORN 9120D-HF VERTICAL            RBW:1000.000KHz VBW:3000.000KHz SWT:Auto            Detector : Peak            Project : 651612            Mode : 8</p>	 <p>Date: 2016-06-25</p> <p>Site : 03CH11-HY            Condition : FCC CLASS-B 3m HORN 9120D-HF VERTICAL            RBW:1000.000KHz VBW:3000.000KHz SWT:Auto            Detector : Peak            Project : 651612            Mode : 8</p>
Avg.	 <p>Date: 2016-06-25</p> <p>Site : 03CH11-HY            Condition : FCC CLASS-B (AVG) 3m HORN 9120D-HF VERTICAL            RBW:1000.000KHz VBW:1000KHz SWT:Auto            Detector : Peak            Project : 651612            Mode : 8</p>	Left blank

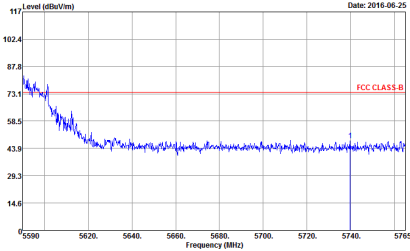
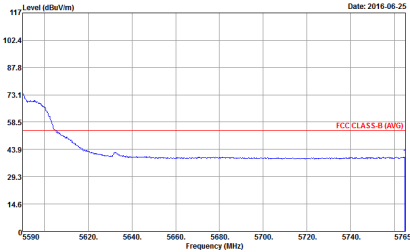

WIFI	Band 3 5470~5725MHz Band Edge @ 3m	
ANT	802.11a CH116 5580MHz - R	
1	Vertical	Fundamental
Peak	 <p>           Site : 03CH11-HY            Condition : FCC CLASS-B 3m HORN 9120D-HF VERTICAL            RBW:1000.000KHz VBW:3000.000KHz SWT:Auto            Detector : Peak            Project : 651612            Mode : B         </p>	Left blank
Avg.	 <p>           Site : 03CH11-HY            Condition : FCC CLASS-B (AVG) 3m HORN 9120D-HF VERTICAL            RBW:1000.000KHz VBW:1000KHz SWT:Auto            Detector : Peak            Project : 651612            Mode : B         </p>	Left blank



WIFI	Band 3 5470~5725MHz Band Edge @ 3m	
ANT	802.11a CH140 5700MHz	
1	<b>Horizontal</b>	<b>Fundamental</b>
Peak	<p>Site : 03CH11-1#Y Condition : FCC PART15E 3m HORN 9120D-HF HORIZONTAL RBW:1000.000KHz VBW:3000.000KHz SWT:Auto Detector : Peak Project : 651612 Mode : 19 : 68.3</p>	<p>Site : 03CH11-1#Y Condition : FCC PART15E 3m HORN 9120D-HF HORIZONTAL RBW:1000.000KHz VBW:3000.000KHz SWT:Auto Detector : Peak Project : 651612 Mode : 19 : 68.3</p>

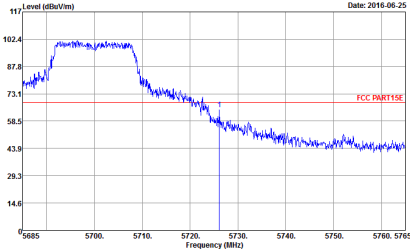
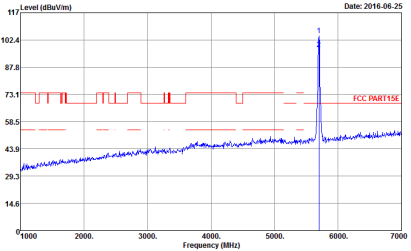

WIFI	Band 3 5470~5725MHz Band Edge @ 3m	
ANT	802.11a CH140 5700MHz	
1	Vertical	Fundamental
Peak	 <p>Date: 2016-08-25</p> <p>Site : 03CH11-#Y            Condition : FCC PART15E 3m HORN 9120D-HF VERTICAL            RBW:1000.000KHz VBW:3000.000KHz SWT:Auto            Detector : Peak            Project : 651612            Mode : 9            : 68.3</p>	 <p>Date: 2016-08-25</p> <p>Site : 03CH11-#Y            Condition : FCC PART15E 3m HORN 9120D-HF VERTICAL            RBW:1000.000KHz VBW:3000.000KHz SWT:Auto            Detector : Peak            Project : 651612            Mode : 9            : 68.3</p>

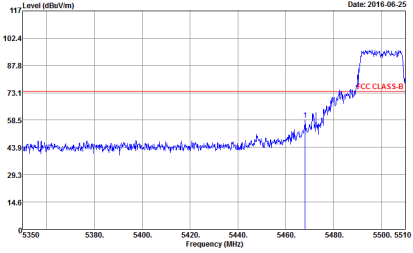
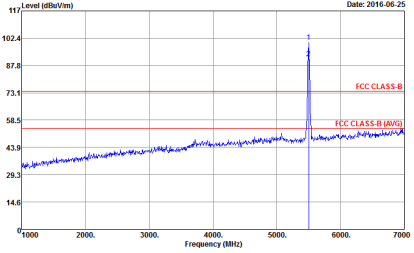
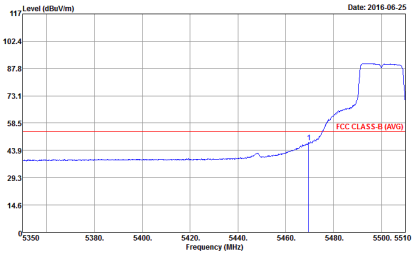

**Band 3 5470~5725MHz  
WIFI 802.11n HT20 (Band Edge @ 3m)**

WIFI	Band 3 5470~5725MHz Band Edge @ 3m	
ANT	802.11n HT20 CH100 5500MHz	
1	Horizontal	Fundamental
<p><b>Peak</b></p>	 <p>Date: 2016-06-25</p> <p>Level (dBuV/m)</p> <p>Frequency (MHz)</p> <p>FCC CLASS-B</p> <p>Site : 03CH11-HY Condition : FCC CLASS-B 3m HORN 9120D-HF HORIZONTAL RBW:1000.000KHz VBW:3000.000KHz SWT:Auto Detector : Peak Project : 651612 Mode : 16</p>	 <p>Date: 2016-06-25</p> <p>Level (dBuV/m)</p> <p>Frequency (MHz)</p> <p>FCC CLASS-B</p> <p>FCC CLASS-B (AVG)</p> <p>Site : 03CH11-HY Condition : FCC CLASS-B 3m HORN 9120D-HF HORIZONTAL RBW:1000.000KHz VBW:3000.000KHz SWT:Auto Detector : Peak Project : 651612 Mode : 16</p>
<p><b>Avg.</b></p>	 <p>Date: 2016-06-25</p> <p>Level (dBuV/m)</p> <p>Frequency (MHz)</p> <p>FCC CLASS-B (AVG)</p> <p>Site : 03CH11-HY Condition : FCC CLASS-B (AVG) 3m HORN 9120D-HF HORIZONTAL RBW:1000.000KHz VBW:1.000KHz SWT:Auto Detector : Peak Project : 651612 Mode : 16</p>	<p>Left blank</p>

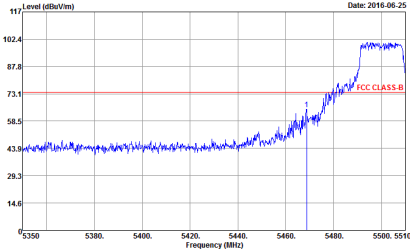
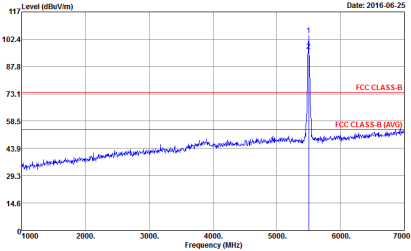
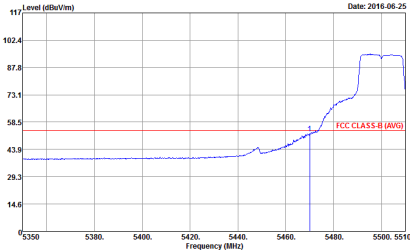

WIFI	Band 3 5470~5725MHz Band Edge @ 3m	
ANT	802.11n HT20 CH100 5500MHz	
1	Vertical	Fundamental
Peak	 <p>Date: 2016-06-25</p> <p>Site : 03CH11-HY            Condition : FCC CLASS-B 3m HORN 9120D-HF VERTICAL            RBW:1000.000KHz VBW:3000.000KHz SWT:Auto            Detector : Peak            Project : 651612            Mode : 16</p>	 <p>Date: 2016-06-25</p> <p>Site : 03CH11-HY            Condition : FCC CLASS-B 3m HORN 9120D-HF VERTICAL            RBW:1000.000KHz VBW:3000.000KHz SWT:Auto            Detector : Peak            Project : 651612            Mode : 16</p>
Avg.	 <p>Date: 2016-06-25</p> <p>Site : 03CH11-HY            Condition : FCC CLASS-B (AVG) 3m HORN 9120D-HF VERTICAL            RBW:1000.000KHz VBW:1000KHz SWT:Auto            Detector : Peak            Project : 651612            Mode : 16</p>	Left blank

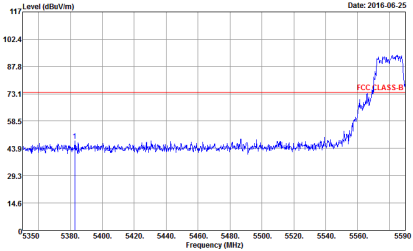
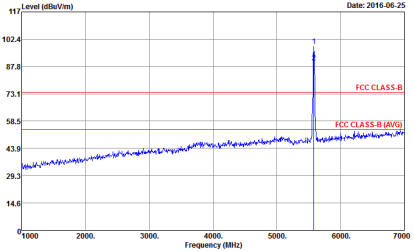
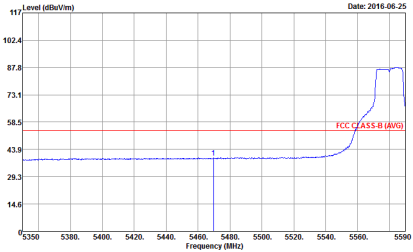

WIFI	Band 3 5470~5725MHz Band Edge @ 3m	
ANT	802.11n HT20 CH116 5580MHz - L	
1	Horizontal	Fundamental
Peak	 <p>Date: 2016-06-25</p> <p>Site : 03CH11-HY            Condition : FCC CLASS-B 3m HORN 9120D-HF HORIZONTAL            RBW:1000.000KHz VBW:3000.000KHz SWT:Auto            Detector : Peak            Project : 651612            Mode : 17</p>	 <p>Date: 2016-06-25</p> <p>Site : 03CH11-HY            Condition : FCC CLASS-B 3m HORN 9120D-HF HORIZONTAL            RBW:1000.000KHz VBW:3000.000KHz SWT:Auto            Detector : Peak            Project : 651612            Mode : 17</p>
Avg.	 <p>Date: 2016-06-25</p> <p>Site : 03CH11-HY            Condition : FCC CLASS-B (AVG) 3m HORN 9120D-HF HORIZONTAL            RBW:1000.000KHz VBW:1000KHz SWT:Auto            Detector : Peak            Project : 651612            Mode : 17</p>	Left blank



WIFI	Band 3 5470~5725MHz Band Edge @ 3m	
ANT	802.11n HT20 CH116 5580MHz - R	
1	Horizontal	Fundamental
Peak	<p>Site : 03CH11-HY Condition : FCC CLASS-B 3m HORN 9120D-HF HORIZONTAL Detector : Peak Project : 651612 Mode : 17</p>	Left blank
Avg.	<p>Site : 03CH11-HY Condition : FCC CLASS-B (AVG) 3m HORN 9120D-HF HORIZONTAL Detector : Peak Project : 651612 Mode : 17</p>	Left blank

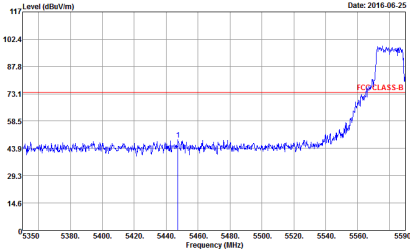
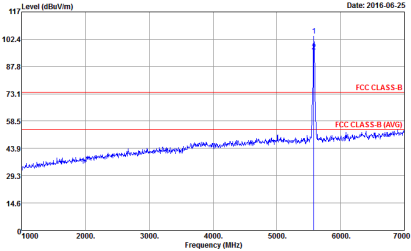
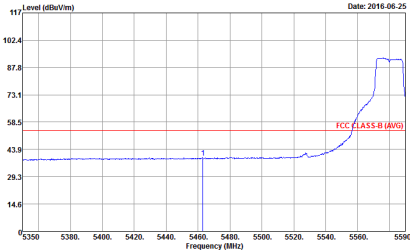

WIFI	Band 3 5470~5725MHz Band Edge @ 3m	
ANT	802.11n HT20 CH116 5580MHz - L	
1	Vertical	Fundamental
Peak	 <p>Date: 2016-06-25</p> <p>Site : 03CH11-HY            Condition : FCC CLASS-B 3m HORN 9120D-HF VERTICAL            RBW:1000.000KHz VBW:3000.000KHz SWT:Auto            Detector : Peak            Project : 651612            Mode : 17</p>	 <p>Date: 2016-06-25</p> <p>Site : 03CH11-HY            Condition : FCC CLASS-B 3m HORN 9120D-HF VERTICAL            RBW:1000.000KHz VBW:3000.000KHz SWT:Auto            Detector : Peak            Project : 651612            Mode : 17</p>
Avg.	 <p>Date: 2016-06-25</p> <p>Site : 03CH11-HY            Condition : FCC CLASS-B (AVG) 3m HORN 9120D-HF VERTICAL            RBW:1000.000KHz VBW:1000KHz SWT:Auto            Detector : Peak            Project : 651612            Mode : 17</p>	Left blank

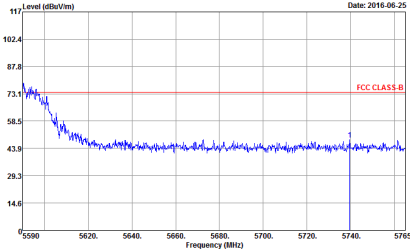
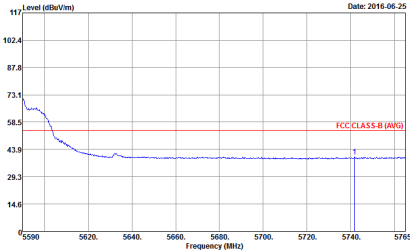

WIFI	Band 3 5470~5725MHz Band Edge @ 3m	
ANT	802.11n HT20 CH116 5580MHz - R	
1	Vertical	Fundamental
Peak	 <p>Date: 2016-06-25</p> <p>Site : 03CH11-HY            Condition : FCC CLASS-B 3m HORN 9120D-HF VERTICAL            RBW:1000.000KHz VBW:3000.000KHz SWT:Auto            Detector : Peak            Project : 651612            Mode : 17</p>	Left blank
Avg.	 <p>Date: 2016-06-25</p> <p>Site : 03CH11-HY            Condition : FCC CLASS-B (AVG) 3m HORN 9120D-HF VERTICAL            RBW:1000.000KHz VBW:1000KHz SWT:Auto            Detector : Peak            Project : 651612            Mode : 17</p>	Left blank

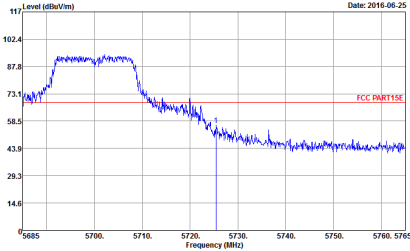
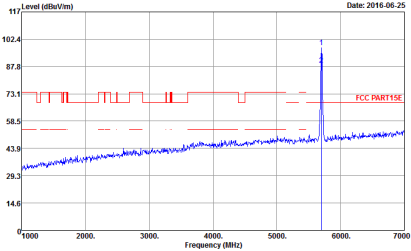

WIFI	Band 3 5470~5725MHz Band Edge @ 3m	
ANT	802.11n HT20 CH140 5700MHz	
1	Horizontal	Fundamental
Peak	 <p>Date: 2016-06-25</p> <p>Site : 03CH11-4Y            Condition : FCC PART15E 3m HORN 9120D-HF HORIZONTAL            RBW:1000.000KHz VBW:3000.000KHz SWT:Auto            Detector : Peak            Project : 651612            Mode : 1B                  : 68.3</p>	 <p>Date: 2016-06-25</p> <p>Site : 03CH11-4Y            Condition : FCC PART15E 3m HORN 9120D-HF HORIZONTAL            RBW:1000.000KHz VBW:3000.000KHz SWT:Auto            Detector : Peak            Project : 651612            Mode : 1B                  : 68.3</p>



WIFI	Band 3 5470~5725MHz Band Edge @ 3m	
ANT	802.11n HT20 CH140 5700MHz	
1	Vertical	Fundamental
<p><b>Peak.</b></p>	<p>Site : 03CH11-4Y            Condition : FCC PART15E 3m HORN 9120D-HF VERTICAL            RBW:1000.000KHz VBW:3000.000KHz SWT:Auto            Detector : Peak            Project : 651612            Mode : 18                  : 68.3</p>	<p>Site : 03CH11-4Y            Condition : FCC PART15E 3m HORN 9120D-HF VERTICAL            RBW:1000.000KHz VBW:3000.000KHz SWT:Auto            Detector : Peak            Project : 651612            Mode : 18                  : 68.3</p>

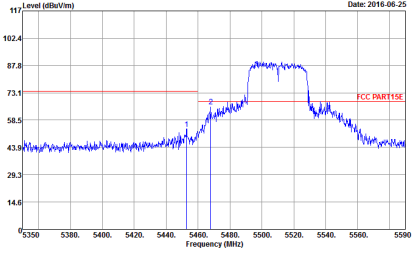
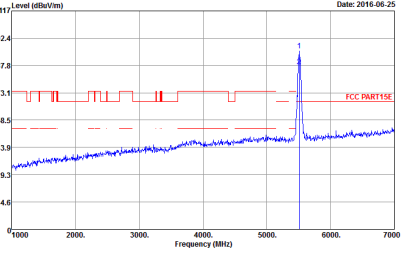
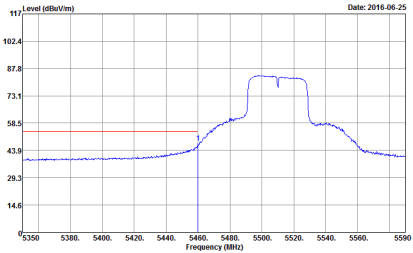

**Band 3 5470~5725MHz  
WIFI 802.11n HT40 (Band Edge @ 3m)**

WIFI	Band 3 5470~5725MHz Band Edge @ 3m	
ANT	802.11n HT40 CH102 5510MHz - L	
1	Horizontal	Fundamental
<b>Peak</b>	 <p>Site : 03CH11-HY Condition : FCC PART15E 3m HORN 9120D-HF HORIZONTAL RBW:1000.000KHz VBW:3000.000KHz SWT:Auto Detector : Peak Project : 651612 Mode : 23 Setting : 14.5 : 68.3</p>	 <p>Site : 03CH11-HY Condition : FCC PART15E 3m HORN 9120D-HF HORIZONTAL RBW:1000.000KHz VBW:3000.000KHz SWT:Auto Detector : Peak Project : 651612 Mode : 23 Setting : 14.5 : 68.3</p>
<b>Avg.</b>	 <p>Site : 03CH11-HY Condition : FCC PART15E (AVG) 3m HORN 9120D-HF HORIZONTAL RBW:1000.000KHz VBW:3.000KHz SWT:Auto Detector : Peak Project : 651612 Mode : 23 Setting : 14.5 : 68.3</p>	<b>Left blank</b>

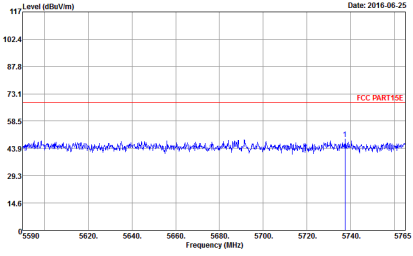

WIFI	Band 3 5470~5725MHz Band Edge @ 3m	
ANT	802.11n HT40 CH102 5510MHz - R	
1	Horizontal	Fundamental
Peak	 <p>Site : 05CH11-FY Condition : FCC PART15E 3m HORN 9120D-HF HORIZONTAL RBW:1000.000KHz VBW:3000.000KHz SWT:Auto Detector : Peak Project : 651612 Mode : 23 Setting : 14.5           : 68.3</p>	Left blank

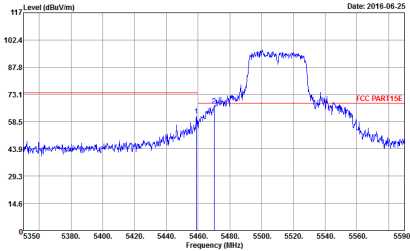
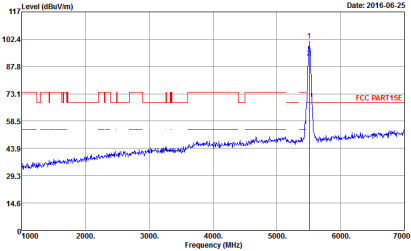
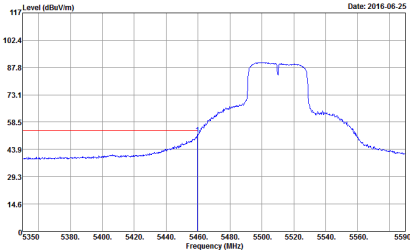

WIFI	Band 3 5470~5725MHz Band Edge @ 3m	
ANT	802.11n HT40 CH102 5510MHz - L	
1	Vertical	Fundamental
Peak	 <p>Site : 03CH11-HY            Condition : FCC PART15E 3m HORN 9120D-HF VERTICAL            RBW:1000.000KHz VBW:3000.000KHz SWT:Auto            Detector : Peak            Project : 651612            Mode : 23            Setting : 14.5                      : 68.3</p>	 <p>Site : 03CH11-HY            Condition : FCC PART15E 3m HORN 9120D-HF VERTICAL            RBW:1000.000KHz VBW:3000.000KHz SWT:Auto            Detector : Peak            Project : 651612            Mode : 23            Setting : 14.5                      : 68.3</p>
Avg.	 <p>Site : 03CH11-HY            Condition : FCC PART15E (AVG) 3m HORN 9120D-HF VERTICAL            RBW:1000.000KHz VBW:3.000KHz SWT:Auto            Detector : Peak            Project : 651612            Mode : 23            Setting : 14.5                      : 68.3</p>	Left blank



WIFI	Band 3 5470~5725MHz Band Edge @ 3m	
ANT	802.11n HT40 CH102 5510MHz - R	
1	Vertical	Fundamental
Peak	<p>Site : 03CH11-HY Condition : FCC PART 15E 3m HORN 9120D-HF VERTICAL Detector : Peak Project : 651612 Mode : 23 Setting : 14.5           : 68.3</p>	Left blank

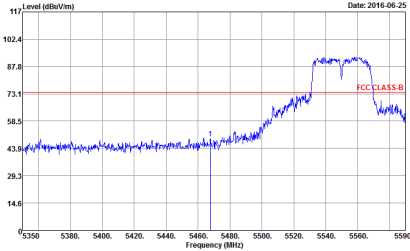
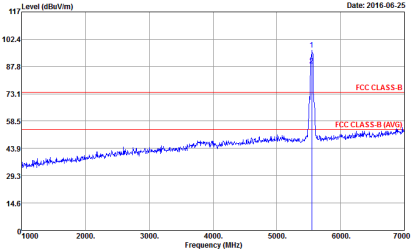
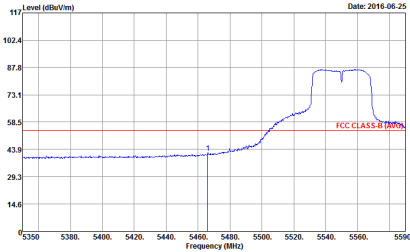

WIFI	Band 3 5470~5725MHz Band Edge @ 3m	
ANT	802.11n HT40 CH110 5550MHz - L	
1	Horizontal	Fundamental
Peak	 <p>Date: 2016-06-25</p> <p>Site : 03CH11-HY            Condition : FCC CLASS-B 3m HORN 9120D-HF HORIZONTAL            RBW:1000.000KHz VBW:3000.000KHz SWT:Auto            Detector : Peak            Project : 651612            Mode : 24</p>	 <p>Date: 2016-06-25</p> <p>Site : 03CH11-HY            Condition : FCC CLASS-B 3m HORN 9120D-HF HORIZONTAL            RBW:1000.000KHz VBW:3000.000KHz SWT:Auto            Detector : Peak            Project : 651612            Mode : 24</p>
Avg.	 <p>Date: 2016-06-25</p> <p>Site : 03CH11-HY            Condition : FCC CLASS-B (AVG) 3m HORN 9120D-HF HORIZONTAL            RBW:1000.000KHz VBW:3.000KHz SWT:Auto            Detector : Peak            Project : 651612            Mode : 24</p>	Left blank



WIFI	Band 3 5470~5725MHz Band Edge @ 3m	
ANT	802.11n HT40 CH110 5550MHz - R	
1	Horizontal	Fundamental
Peak	<p>Site : 03CH11-HY Condition : FCC CLASS-B 3m HORN 9120D-HF HORIZONTAL Detector : Peak Project : 651612 Mode : 24</p>	Left blank
Avg.	<p>Site : 03CH11-HY Condition : FCC CLASS-B (AVG) 3m HORN 9120D-HF HORIZONTAL Detector : Peak Project : 651612 Mode : 24</p>	Left blank

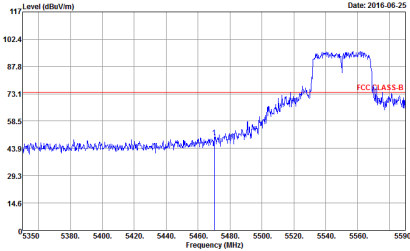
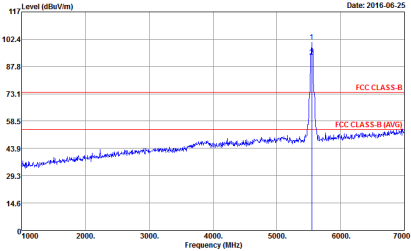
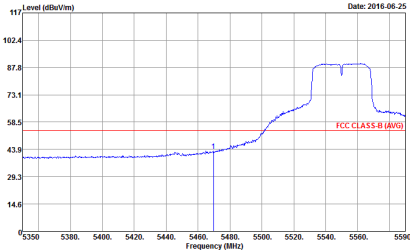

WIFI	Band 3 5470~5725MHz Band Edge @ 3m	
ANT	802.11n HT40 CH110 5550MHz - L	
1	Vertical	Fundamental
Peak	 <p>Date: 2016-06-25</p> <p>Site : 03CH11-HY            Condition : FCC CLASS-B 3m HORN 9120D-HF VERTICAL            RBW:1000.000KHz VBW:3000.000KHz SWT:Auto            Detector : Peak            Project : 651612            Mode : 24</p>	 <p>Date: 2016-06-25</p> <p>Site : 03CH11-HY            Condition : FCC CLASS-B 3m HORN 9120D-HF VERTICAL            RBW:1000.000KHz VBW:3000.000KHz SWT:Auto            Detector : Peak            Project : 651612            Mode : 24</p>
Avg.	 <p>Date: 2016-06-25</p> <p>Site : 03CH11-HY            Condition : FCC CLASS-B (AVG) 3m HORN 9120D-HF VERTICAL            RBW:1000.000KHz VBW:3.000KHz SWT:Auto            Detector : Peak            Project : 651612            Mode : 24</p>	Left blank

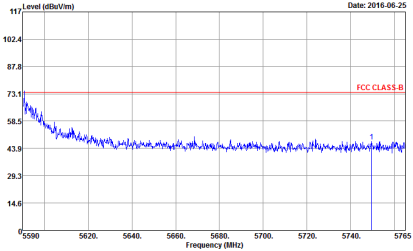
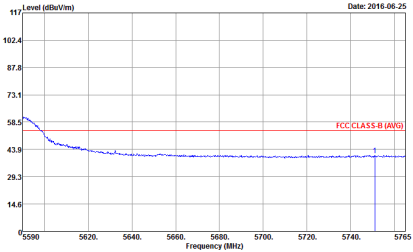

WIFI	Band 3 5470~5725MHz Band Edge @ 3m	
ANT	802.11n HT40 CH110 5550MHz - R	
1	Vertical	Fundamental
Peak	 <p>           Site : 03CH11-HY            Condition : FCC CLASS-B 3m HORN 9120D-HF VERTICAL            RBW:1000.000KHz VBW:3000.000KHz SWT:Auto            Detector : Peak            Project : 651612            Mode : 24         </p>	Left blank
Avg.	 <p>           Site : 03CH11-HY            Condition : FCC CLASS-B (AVG) 3m HORN 9120D-HF VERTICAL            RBW:1000.000KHz VBW:3.000KHz SWT:Auto            Detector : Peak            Project : 651612            Mode : 24         </p>	Left blank

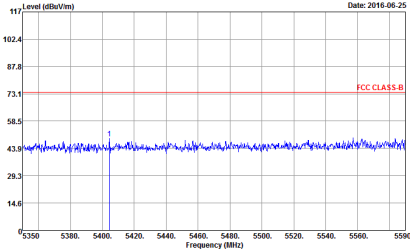
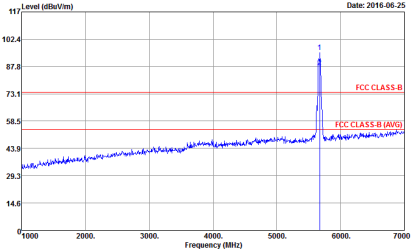
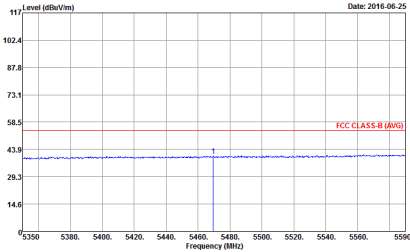

WIFI	Band 3 5470~5725MHz Band Edge @ 3m	
ANT	802.11n HT40 CH134 5670MHz - L	
1	Horizontal	Fundamental
Peak	 <p>Date: 2016-06-25</p> <p>Site : 03CH11-HY            Condition : FCC CLASS-B 3m HORN 9120D-HF HORIZONTAL            RBW:1000.000KHz VBW:3000.000KHz SWT:Auto            Detector : Peak            Project : 651612            Mode : 25</p>	 <p>Date: 2016-06-25</p> <p>Site : 03CH11-HY            Condition : FCC CLASS-B 3m HORN 9120D-HF HORIZONTAL            RBW:1000.000KHz VBW:3000.000KHz SWT:Auto            Detector : Peak            Project : 651612            Mode : 25</p>
Avg.	 <p>Date: 2016-06-25</p> <p>Site : 03CH11-HY            Condition : FCC CLASS-B (AVG) 3m HORN 9120D-HF HORIZONTAL            RBW:1000.000KHz VBW:3.000KHz SWT:Auto            Detector : Peak            Project : 651612            Mode : 25</p>	Left blank



WIFI	Band 3 5470~5725MHz Band Edge @ 3m	
ANT	802.11n HT40 CH134 5670MHz - R	
1	Horizontal	Fundamental
Peak	<p>Site : 03CH11-HY            Condition : FCC CLASS-B 3m HORN 9120D-HF HORIZONTAL            Detector : Peak            Project : 651612            Mode : 25</p>	Left blank
Avg.	<p>Site : 03CH11-HY            Condition : FCC CLASS-B (AVG) 3m HORN 9120D-HF HORIZONTAL            Detector : Peak            Project : 651612            Mode : 25</p>	Left blank

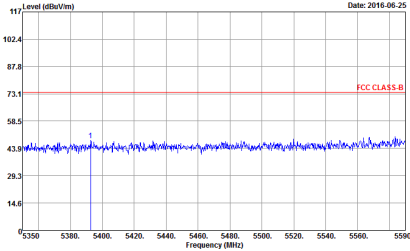
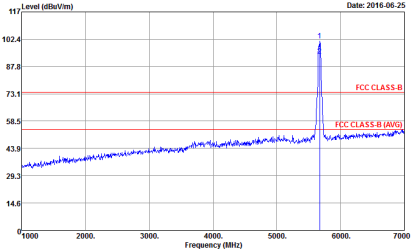
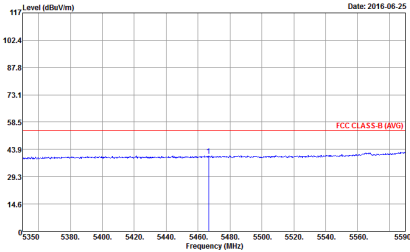

WIFI	Band 3 5470~5725MHz Band Edge @ 3m	
ANT	802.11n HT40 CH134 5670MHz - L	
1	Vertical	Fundamental
Peak	 <p>Date: 2016-06-25</p> <p>Site : 03CH11-HY            Condition : FCC CLASS-B 3m HORN 9120D-HF VERTICAL            RBW:1000.000KHz VBW:3000.000KHz SWT:Auto            Detector : Peak            Project : 651612            Mode : 25</p>	 <p>Date: 2016-06-25</p> <p>Site : 03CH11-HY            Condition : FCC CLASS-B 3m HORN 9120D-HF VERTICAL            RBW:1000.000KHz VBW:3000.000KHz SWT:Auto            Detector : Peak            Project : 651612            Mode : 25</p>
Avg.	 <p>Date: 2016-06-25</p> <p>Site : 03CH11-HY            Condition : FCC CLASS-B (AV6) 3m HORN 9120D-HF VERTICAL            RBW:1000.000KHz VBW:3.000KHz SWT:Auto            Detector : Peak            Project : 651612            Mode : 25</p>	Left blank

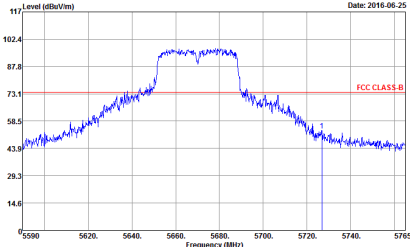
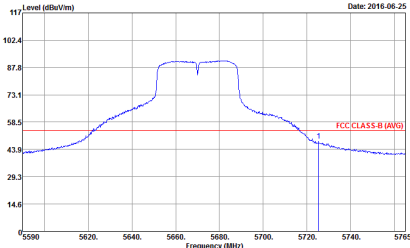

WIFI	Band 3 5470~5725MHz Band Edge @ 3m	
ANT	802.11n HT40 CH134 5670MHz - R	
1	Vertical	Fundamental
Peak	 <p>Date: 2016-06-25</p> <p>Site : 03CH11-HY  Condition : FCC CLASS-B 3m HORN 9120D-HF VERTICAL  RBW:1000.000KHz VBW:3000.000KHz SWT:Auto  Detector : Peak  Project : 651612  Mode : 25</p>	Left blank
Avg.	 <p>Date: 2016-06-25</p> <p>Site : 03CH11-HY  Condition : FCC CLASS-B (AVG) 3m HORN 9120D-HF VERTICAL  RBW:1000.000KHz VBW:3.000KHz SWT:Auto  Detector : Peak  Project : 651612  Mode : 25</p>	Left blank



Band 3 5470~5725MHz

Band 3 - 5470~5725MHz

WIFI 802.11a (Harmonic @ 3m)

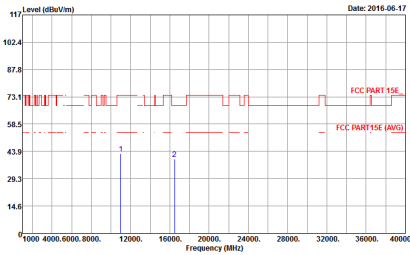
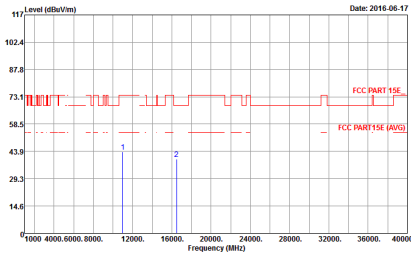
WIFI	Band 3 5470~5725MHz Harmonic @ 3m	
ANT	802.11a CH100 5500MHz	
1	Horizontal	Vertical
<p><b>Peak</b></p> <p><b>Avg.</b></p>	 <p>Site : 03CH11-HY            Condition : FCC PART 15E_3m 9170 SHF HORM_150809 HORIZONTAL            Detector : Peak            Project : 651612            Mode : 7</p>	 <p>Site : 03CH11-HY            Condition : FCC PART 15E_3m 9170 SHF HORM_150809 VERTICAL            Detector : Peak            Project : 651612            Mode : 7</p>

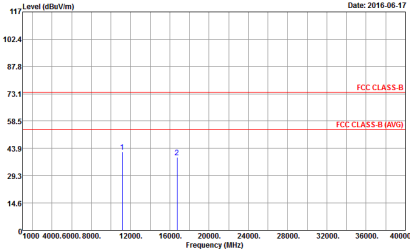
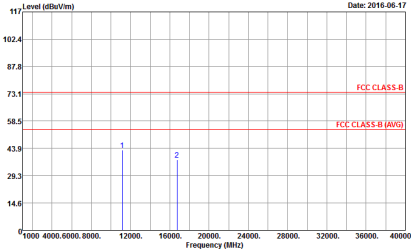

WIFI	Band 3 5470~5725MHz Harmonic @ 3m	
ANT	802.11a CH116 5580MHz	
1	Horizontal	Vertical
<p><b>Peak</b></p> <p><b>Avg.</b></p>	 <p>Date: 2016-06-17</p> <p>Site : 03CH11-HY            Condition : FCC CLASS-B 3m 9170 SHF HORM_150809 HORIZONTAL            Detector : Peak            Project : 651612            Mode : 8</p>	 <p>Date: 2016-06-17</p> <p>Site : 03CH11-HY            Condition : FCC CLASS-B 3m 9170 SHF HORM_150809 VERTICAL            Detector : Peak            Project : 651612            Mode : 8</p>



WIFI	Band 3 5470~5725MHz Harmonic @ 3m	
ANT	802.11a CH140 5700MHz	
1	Horizontal	Vertical
Peak Avg.	<p>Site : 03CH11-HY Condition : FCC PART 15E_3m 9170 SHF HORM_150809 HORIZONTAL Detector : Peak Project : 651612 Mode : 9</p>	<p>Site : 03CH11-HY Condition : FCC PART 15E_3m 9170 SHF HORM_150809 VERTICAL Detector : Peak Project : 651612 Mode : 9</p>



Band 3 5470~5725MHz
WIFI 802.11n HT20 (Harmonic @ 3m)

Table with 2 columns: Horizontal and Vertical. Each column contains a graph of Level (dBuV/m) vs Frequency (MHz) and associated test parameters like Site, Condition, Detector, Project, and Mode.

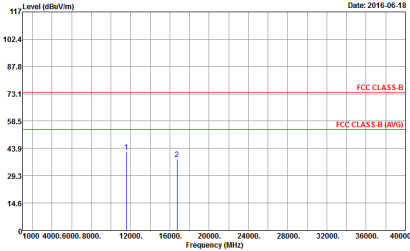
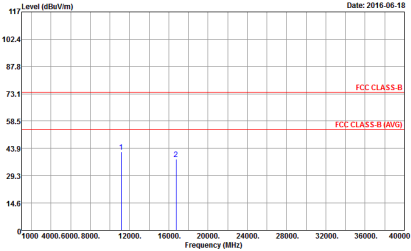

WIFI	Band 3 5470~5725MHz Harmonic @ 3m	
ANT	802.11n HT20 CH116 5580MHz	
1	Horizontal	Vertical
<p>Peak</p> <p>Avg.</p>	 <p>Site : 03CH11-HY  Condition : FCC CLASS-B 3m 9170 SHF HORM_150809 HORIZONTAL  Detector : Peak  Project : 651612  Mode : 17</p>	 <p>Site : 03CH11-HY  Condition : FCC CLASS-B 3m 9170 SHF HORM_150809 VERTICAL  Detector : Peak  Project : 651612  Mode : 17</p>



WIFI	Band 3 5470~5725MHz Harmonic @ 3m	
ANT	802.11n HT20 CH140 5700MHz	
1	Horizontal	Vertical
Peak Avg.	<p>Site : 03CH11-HY Condition : FCC PART 15E_3m 9170 SHF HORM_150809 HORIZONTAL Detector : Peak Project : 651612 Mode : 18</p>	<p>Site : 03CH11-HY Condition : FCC PART 15E_3m 9170 SHF HORM_150809 VERTICAL Detector : Peak Project : 651612 Mode : 18</p>



Band 3 5470~5725MHz
WIFI 802.11n HT40 (Harmonic @ 3m)

Table with 2 columns: Horizontal and Vertical. It contains two spectral plots showing Level (dBuV/m) vs Frequency (MHz) for FCC PART 15E. The plots include peak and average level markers and associated test parameters like Site, Condition, Detector, Project, and Mode.

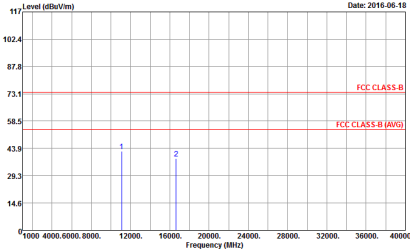
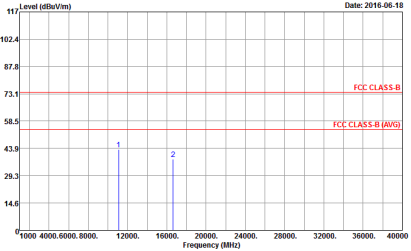

WIFI	Band 3 5470~5725MHz Harmonic @ 3m	
ANT	802.11n HT40 CH110 5550MHz	
1	Horizontal	Vertical
Peak Avg.	 <p>Site : 03CH11-HY Condition : FCC CLASS-B 3m 9170 SHF HORM_150809 HORIZONTAL Detector : Peak Project : 651612 Mode : Z4</p>	 <p>Site : 03CH11-HY Condition : FCC CLASS-B 3m 9170 SHF HORM_150809 VERTICAL Detector : Peak Project : 651612 Mode : Z4</p>



WIFI	Band 3 5470~5725MHz Harmonic @ 3m	
ANT	802.11n HT40 CH134 5670MHz	
1	Horizontal	Vertical
Peak Avg.	<p>Site : 03CH11-HY Condition : FCC CLASS-B 3m 9170 SHF HORM_150809 HORIZONTAL Detector : Peak Project : 651612 Mode : 25</p>	<p>Site : 03CH11-HY Condition : FCC CLASS-B 3m 9170 SHF HORM_150809 VERTICAL Detector : Peak Project : 651612 Mode : 25</p>



Band 3 5470~5725MHz

Emission below 1GHz

5GHz WIFI 802.11a (LF)

WIFI	5GHz WIFI	
ANT	802.11a LF	
1	Horizontal	Vertical
QP / Peak	<p>Site : 03CH11-HY Condition : FCC CLASS-B 3m BT-LO6 6111D-LF_ETC HORIZONTAL Detector : Peak Project : 651612 Mode : 34</p>	<p>Site : 03CH11-HY Condition : FCC CLASS-B 3m BT-LO6 6111D-LF_ETC VERTICAL Detector : Peak Project : 651612 Mode : 34</p>

## Appendix D. Duty Cycle Plots

Antenna	Band	Duty Cycle(%)	T(us)	1/T(kHz)	VBW Setting
1	802.11a	86.984	1370	0.729927007	1kHz
1	5GHz 802.11n HT20	86.486	1280	0.78125	1kHz
1	5GHz 802.11n HT40	75.598	632	1.582278481	3kHz

### 802.11a

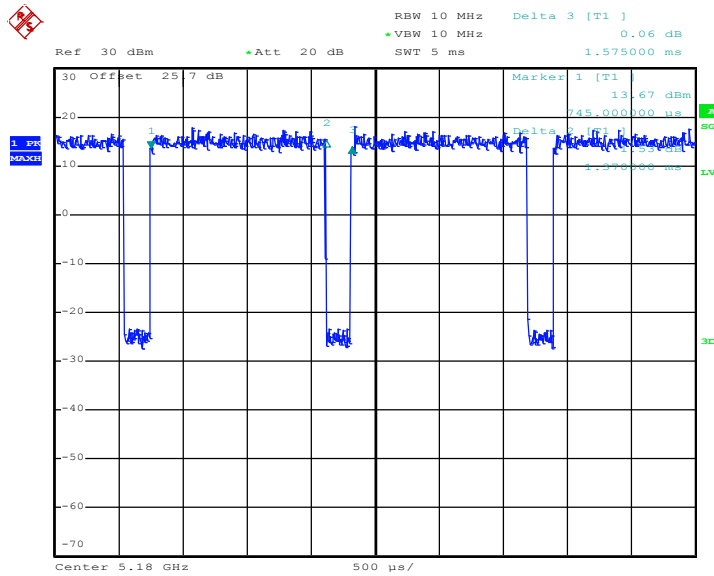

Date: 22.MAY.2016 09:02:32



### 802.11n HT20

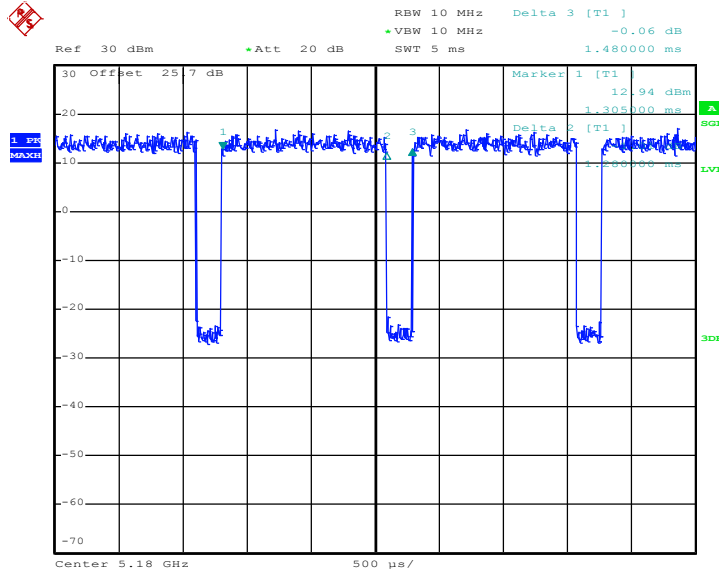

Date: 22.MAY.2016 09:08:23

### 802.11n HT40

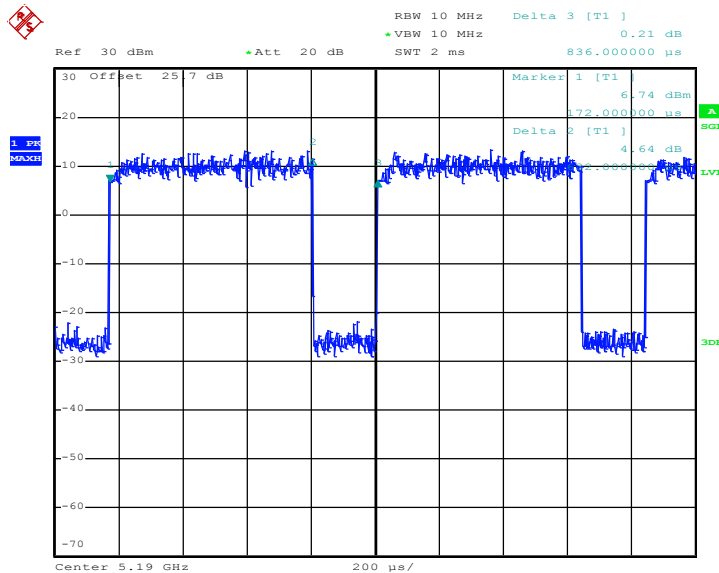

Date: 22.MAY.2016 09:23:04