



FCC RF Test Report

APPLICANT : Motorola Mobility, LLC
EQUIPMENT : Mobile Cellular Phone
BRAND NAME : Motorola
MODEL NAME : 6576
FCC ID : IHDT56VB4
STANDARD : FCC Part 15 Subpart C §15.225
CLASSIFICATION : (DXX) Low Power Communication Device Transmitter

The testing was completed on Jul. 31, 2016. We, SPORTON INTERNATIONAL INC., would like to declare that the tested sample has been evaluated in accordance with the test procedures and has been in compliance with the applicable technical standards.

The test results in this report apply exclusively to the tested model / sample. Without written approval of SPORTON INTERNATIONAL INC., the test report shall not be reproduced except in full.

Reviewed by: Joseph Lin / Supervisor

Approved by: Jones Tsai / Manager



SPORTON INTERNATIONAL INC.

No. 52, Hwa Ya 1st Rd., Hwa Ya Technology Park, Kwei-Shan District, Tao Yuan City, Taiwan, R.O.C.



Table of Contents

SUMMARY OF THE TEST RESULT4
1. GENERAL INFORMATION.....5
1.1 Applicant5
1.2 Manufacturer.....5
1.3 Feature of Equipment Under Test5
1.4 Product Details.....6
1.5 Modification of EUT.....6
1.6 Testing Location7
1.7 Applicable Standards7
1.8 Test Modes.....7
1.9 Test Configurations.....8
1.10 Table for Supporting Units10
2. CONDUCTED EMISSION TEST.....11
2.1 Measuring Instruments11
2.2 Test setup11
2.3 Test Result of Conducted Emission Test.....11
2.4 AC Power Line Conducted Emissions Measurement12
3. RADIATED TEST ITEMS.....13
3.1 Measuring Instruments13
3.2 Test Setup13
3.3 Test Result of Radiated Test Items13
3.4 Field Strength of Fundamental Emissions and Mask Measurement14
3.5 Radiated Emissions Measurement15
4. LIST OF MEASURING EQUIPMENT17
APPENDIX A. TEST RESULTS OF CONDUCTED EMISSION TEST
APPENDIX B. TEST RESULTS OF RADIATED TEST ITEMS
B.1 Test Result of Field Strength of Fundamental Emissions
B.2 Results of Radiated Emissions (9 kHz~30MHz)
B.3 Results of Radiated Emissions (30MHz~1GHz)
APPENDIX C. ORIGINAL REPORT



SUMMARY OF THE TEST RESULT

Applied Standard: 47 CFR FCC Part 15 Subpart C				
Part	FCC Rule	Description of Test	Result	Under Limit
3.1	15.207	AC Power Line Conducted Emissions	Complies	2.10 dB at 0.246MHz
3.2	15.225(a)(b)(c)	Field Strength of Fundamental Emissions	Complies	57.76 dB at 13.560 MHz
3.4	15.225(d) 15.209	Radiated Emissions	Complies	6.28 dB at 52.950 MHz
3.6	15.203	Antenna Requirements	Complies	-

Test Items	Uncertainty	Remark
AC Power Line Conducted Emissions	±2.26dB	Confidence levels of 95%
Radiated Emissions (30MHz~1000MHz)	±4.80dB	Confidence levels of 95%



1. GENERAL INFORMATION

1.1 Applicant

Motorola Mobility, LLC

222 W Merchandise Mart Plaza, Suite 1800, Chicago, IL 60654, United States

1.2 Manufacturer

Motorola Mobility, LLC

222 W Merchandise Mart Plaza, Suite 1800, Chicago, IL 60654, United States

1.3 Feature of Equipment Under Test

Product Feature	
Equipment	Mobile Cellular Phone
Brand Name	Motorola
FCC Model Name	6576
FCC ID	IHDT56VB4
IMEI Code	358180070002341 (for Radiation) 358180070002314 (for Conduction)
EUT supports Radios application	GSM/EGPRS/WCDMA/HSPA/LTE/NFC WLAN 11b/g/n HT20/VHT20 WLAN 11a/n HT20/HT40 WLAN 11ac VHT20/VHT40/VHT80 Bluetooth v3.0 EDR Bluetooth v4.2 LE
HW Version	DVT2
EUT Stage	Identical Prototype

Accessory List	
WPC Cover	Brand Name : INCIPIO
	Model Name : MT-043-CASE



1.4 Product Details

Items	Description
Tx/Rx Frequency Range	13.553 ~ 13.567MHz
Channel Number	1
Antenna Type	Fixed Internal Antenna
Type of Modulation	ASK

Remark: The above EUT's information was declared by manufacturer. Please refer to the specifications or user's manual for more detailed description.

1.5 Modification of EUT

No modifications are made to the EUT during all test items.



1.6 Testing Location

Sporton Lab is accredited to ISO 17025 by Taiwan Accreditation Foundation (TAF code : 1190) and the FCC designation No. TW1022 under the FCC 2.948(e) by Mutual Recognition Agreement (MRA) in FCC Test.

Test Site	SPORTON INTERNATIONAL INC.	
Test Site Location	No. 52, Hwa Ya 1 st Rd., Hwa Ya Technology Park, Kwei-Shan District, Tao Yuan City, Taiwan, R.O.C. TEL: +886-3-3273456 / FAX: +886-3-3284978	
Test Site No.	Sporton Site No.	
	CO05-HY	03CH07-HY
Test Engineer	Kai-Chun Chu	Derreck Chen
Temperature	22~23°C	21~22°C
Relative Humidity	48~50%	49~50%

Note: The test site complies with ANSI C63.4 2014 requirement.

1.7 Applicable Standards

According to the specifications of the manufacturer, the EUT must comply with the requirements of the following standards:

- ♦ FCC Part 15 Subpart C §15.225
- ♦ ANSI C63.10-2013

1.8 Test Modes

Investigation has been done on all the possible configurations for searching the worst cases. The following table is a list of the test modes shown in this test report.

Test Items	
AC Power Line Conducted Emissions	Field Strength of Fundamental Emissions
Radiated Emissions 9kHz~30MHz	Radiated Emissions 30MHz~1GHz
Note:	
1. The EUT was programmed to be in continuously transmitting mode.	
2. The ancillary equipment, NFC card, is used to make the EUT (NFC) continuously transmit at 13.56MHz and is placed around 3 cm gap to the EUT.	

1.9 Test Configurations

<AC Conducted Emission with WPC Charging Mode>

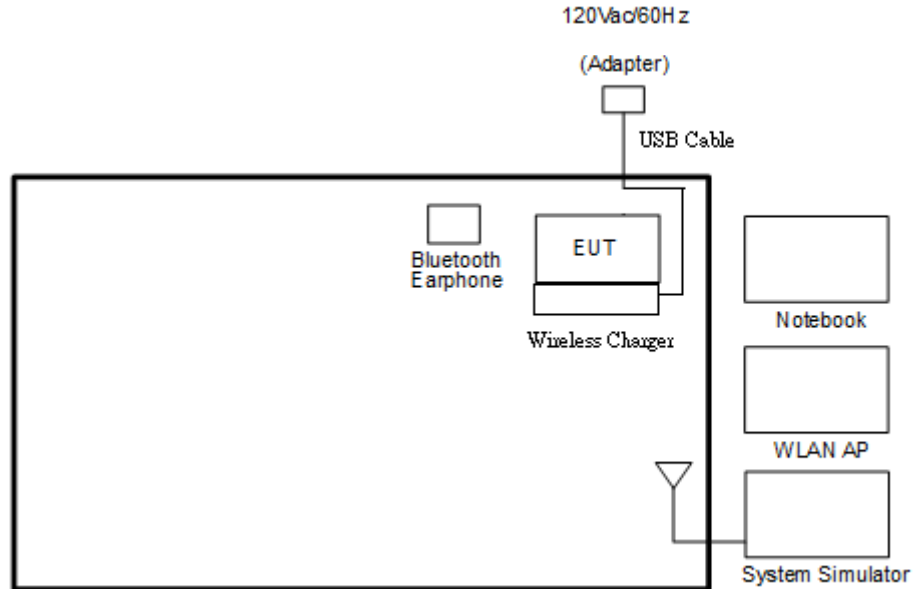

<AC Conducted Emission with PMA Charging Mode>

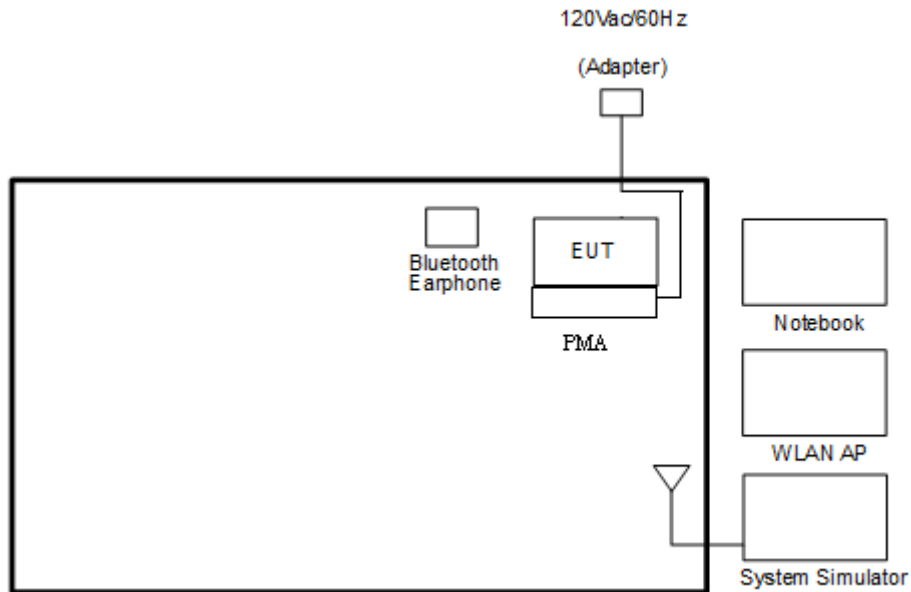

<For Fundamental Emissions and Mask and Radiated Emissions Measurement with WPC Charging Mode >

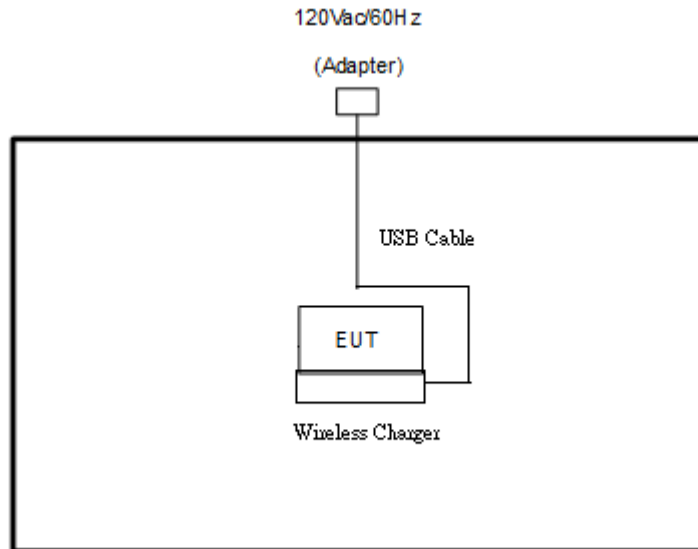

<For Fundamental Emissions and Mask and Radiated Emissions Measurement with PMA Charging Mode >

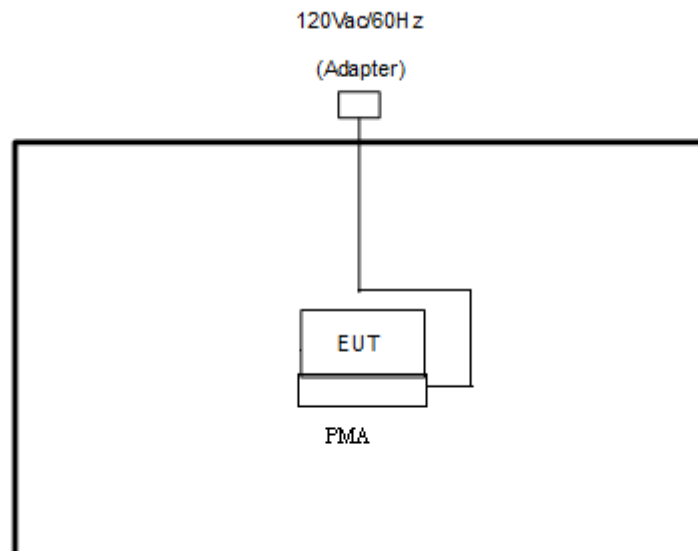



1.10 Table for Supporting Units

Support Unit	Manufacturer	Model	FCC ID
System Simulator	Anritsu	MT8820C	N/A
WLAN AP	D-Link	DIR-628	KA2DIR628A2
Bluetooth Earphone	Sony Ericsson	MW600	PY70DA2029
Notebook	DELL	Latitude E6320	FCC DoC/ Contains FCC ID: QDS-BRCM1054
SD Card	SanDisk	MicroSD HC	FCC DoC
NFC Card	Metro Taipei	Easy Card	N/A
Wireless Charger	LG	WCD-100	FCC DoC
PMA	DURACELL	M-018B-518A	FCC DoC
USB Cable	Motorola	SKN6461A	N/A
Adapter	Motorola	SPN5865A	N/A

2. CONDUCTED EMISSION TEST

2.1 Measuring Instruments

See list of measuring instruments of this test report.

2.2 Test setup

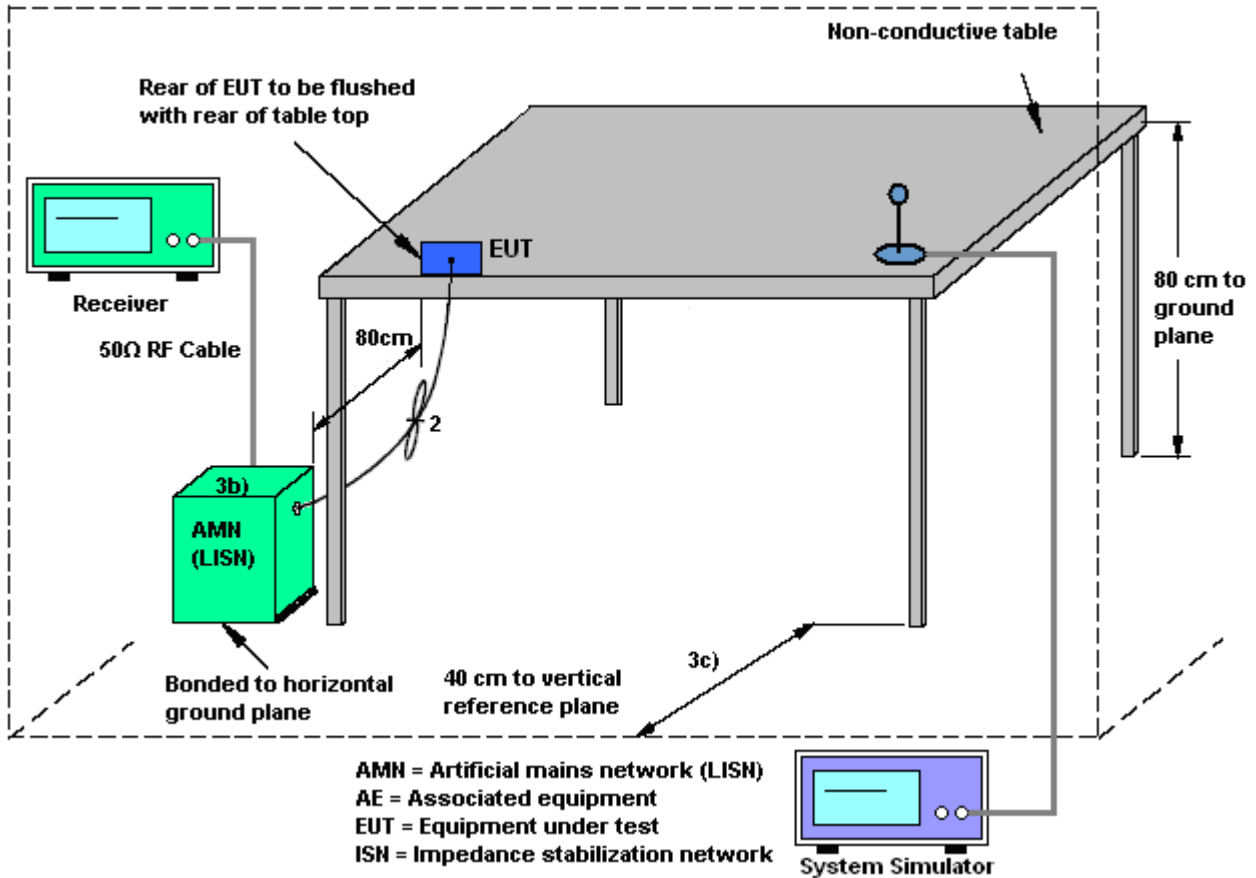

2.3 Test Result of Conducted Emission Test

Please refer to Appendix A.



2.4 AC Power Line Conducted Emissions Measurement

2.4.1 Limit

For equipment that is designed to be connected to the public utility (AC) power line, the radio frequency voltage that is conducted back onto the AC power line on any frequency or frequencies within the band 150 kHz to 30 MHz shall not exceed the limits in the following table.

Frequency of Emission (MHz)	Conducted Limit (dB μ V)	
	Quasi-Peak	Average
0.15-0.5	66 to 56*	56 to 46*
0.5-5	56	46
5-30	60	50

*Decreases with the logarithm of the frequency.

2.4.2 Test Procedures

1. The EUT was placed 0.4 meter from the conducting wall of the shielding room, and it was kept at least 80 centimeters from any other grounded conducting surface.
2. Connect EUT to the power mains through a line impedance stabilization network (LISN).
3. All the support units are connecting to the other LISN.
4. The LISN provides 50 ohm coupling impedance for the measuring instrument.
5. The FCC states that a 50 ohm, 50 microhenry LISN should be used.
6. Both sides of AC line were checked for maximum conducted interference.
7. The frequency range from 150 kHz to 30 MHz was searched.
8. Set the test-receiver system to Peak Detect Function and specified bandwidth (IF Bandwidth = 9kHz) with Maximum Hold Mode. Then measurement is also conducted by Average Detector and Quasi-Peak Detector Function respectively.

3. RADIATED TEST ITEMS

3.1 Measuring Instruments

See list of measuring instruments of this test report.

3.2 Test Setup

3.2.1 For radiated emissions below 30MHz

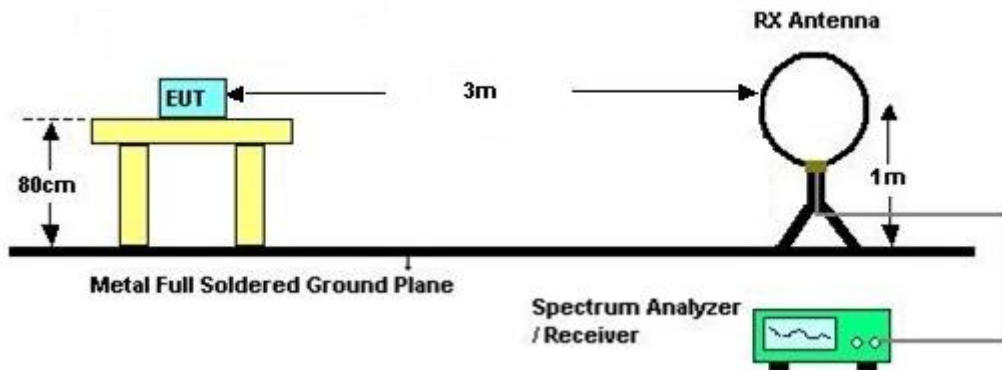

3.2.2 For radiated emissions above 30MHz

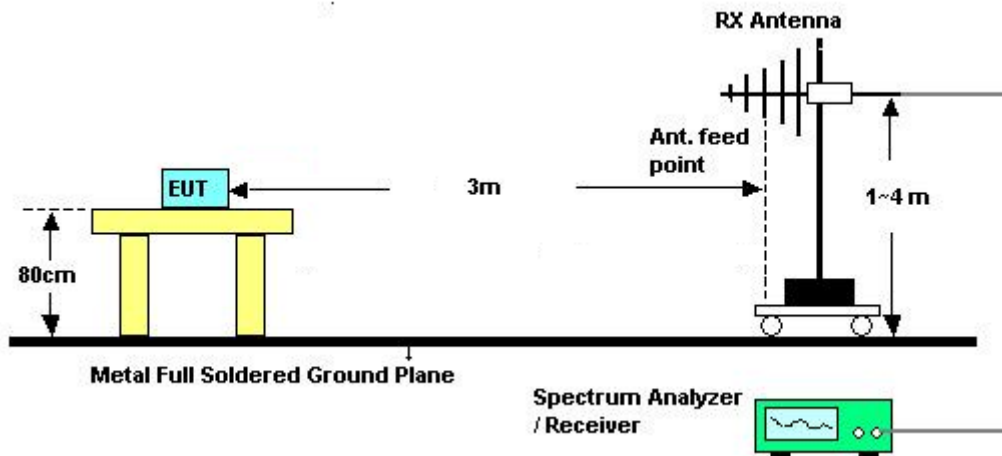

3.3 Test Result of Radiated Test Items

Please refer to Appendix B.



3.4 Field Strength of Fundamental Emissions and Mask Measurement

3.4.1 Limit

Rules and specifications	FCC CFR 47 Part 15 section 15.225 IC RSS-210 A2.6			
	Description			
Description	Compliance with the spectrum mask is tested with RBW set to 9kHz.			
Freq. of Emission (MHz)	Field Strength (µV/m) at 30m	Field Strength (dBµV/m) at 30m	Field Strength (dBµV/m) at 10m	Field Strength (dBµV/m) at 3m
1.705~13.110	30	29.5	48.58	69.5
13.110~13.410	106	40.5	59.58	80.5
13.410~13.553	334	50.5	69.58	90.5
13.553~13.567	15848	84.0	103.08	124.0
13.567~13.710	334	50.5	69.58	90.5
13.710~14.010	106	40.5	59.58	80.5
14.010~30.000	30	29.5	48.58	69.5

3.4.2 Test Procedures

1. Configure the EUT according to ANSI C63.10. The EUT was placed on the top of the turntable 0.8 meter above ground. The phase center of the loop receiving antenna mounted antenna tower was placed 3 meters far away from the turntable.
2. Power on the EUT and all the supporting units. The turntable was rotated by 360 degrees to determine the position of the highest radiation.
3. The height of the receiving antenna was fixed at one meter above ground to find the maximum emissions field strength.
4. For Fundamental emissions, use the receiver to measure QP reading.
5. When the radiated emissions limits are expressed in terms of the average value of the emissions, and pulsed operation is employed, the measurement field strength shall be determined by averaging over one complete pulse train, including blanking intervals, as long as the pulse train does not exceed 0.1 seconds. As an alternative (provided the transmitter operates for longer than 0.1 seconds) or in cases where the pulse train exceeds 0.1 seconds, the measured field strength shall be determined from the average absolute voltage during a 0.1 second interval during which the field strength is at its maximum value.
6. Compliance with the spectrum mask is tested with RBW set to 9kHz.

Note: Emission level (dBµV/m) = 20 log Emission level (µV/m).



3.5 Radiated Emissions Measurement

3.5.1 Limit

The field strength of any emissions which appear outside of 13.110 ~14.010MHz band shall not exceed the general radiated emissions limits.

Frequencies (MHz)	Field Strength (µV/m)	Measurement Distance (meters)
0.009~0.490	2400/F(kHz)	300
0.490~1.705	24000/F(kHz)	30
1.705~30.0	30	30
30~88	100	3
88~216	150	3
216~960	200	3
Above 960	500	3

3.5.2 Measuring Instrument Setting

The following table is the setting of receiver.

Receiver Parameter	Setting
Attenuation	Auto
Frequency Range: 9kHz~150kHz	RBW 200Hz for QP
Frequency Range: 150kHz~30MHz	RBW 9kHz for QP
Frequency Range: 30MHz~1000MHz	RBW 120kHz for Peak

Note: The emission limits shown in the above table are based on measurements employing a CISPR quasi-peak detector except for the frequency bands 9-90 kHz, 110-490 kHz. Radiated emission limits in these two bands are based on measurements employing an average detector.



3.5.3 Test Procedures

1. Configure the EUT according to ANSI C63.10. The EUT was placed on the top of the turntable 0.8 meter above ground. The phase center of the receiving antenna mounted on the top of a height-variable antenna tower was placed 3 meters far away from the turntable.
1. Power on the EUT and all the supporting units. The turntable was rotated by 360 degrees to determine the position of the highest radiation.
2. The height of the broadband receiving antenna was varied between one meter and four meters above ground to find the maximum emissions field strength of both horizontal and vertical polarization.
3. For each suspected emissions, the antenna tower was scan (from 1 M to 4 M) and then the turntable was rotated (from 0 degree to 360 degrees) to find the maximum reading.
4. Set the test-receiver system to Peak or CISPR quasi-peak Detect Function with specified bandwidth under Maximum Hold Mode.
5. When the radiated emissions limits are expressed in terms of the average value of the emissions, and pulsed operation is employed, the measurement field strength shall be determined by averaging over one complete pulse train, including blanking intervals, as long as the pulse train does not exceed 0.1 seconds. As an alternative (provided the transmitter operates for longer than 0.1 seconds) or in cases where the pulse train exceeds 0.1 seconds, the measured field strength shall be determined from the average absolute voltage during a 0.1 second interval during which the field strength is at its maximum value.
6. In case the emission is lower than 30MHz, loop antenna has to be used for measurement and the recorded data should be QP measured by receiver. Antenna Requirements

3.5.4 Limit

Except for special regulations, the Low-power Radio-frequency Devices must not be equipped with any jacket for installing an antenna with extension cable. An intentional radiator shall be designed to ensure that no antenna other than that furnished by the responsible party shall be used with the device. The use of a permanently attached antenna or of an antenna that uses a unique coupling to the intentional radiator shall be considered sufficient to comply with the provisions of this Section. The manufacturer may design the unit so that the user can replace a broken antenna, but the use of a standard antenna jack or electrical connector is prohibited.

3.5.5 Antenna Anti-Replacement Construction

An embedded-in antenna design is used.



4. LIST OF MEASURING EQUIPMENT

Instrument	Manufacturer	Model No.	Serial No.	Characteristics	Calibration Date	Test Date	Due Date	Remark
AC Power Source	ChainTek	APC-1000W	N/A	N/A	N/A	Jul. 29, 2016 ~ Jul. 30, 2016	N/A	Conduction (CO05-HY)
EMI Test Receiver	Rohde & Schwarz	ESCI 7	100724	9kHz~7GHz	Aug. 26, 2015	Jul. 29, 2016 ~ Jul. 30, 2016	Aug. 25, 2016	Conduction (CO05-HY)
LISN	Rohde & Schwarz	ENV216	100080	9kHz~30MHz	Dec. 02, 2015	Jul. 29, 2016 ~ Jul. 30, 2016	Dec. 01, 2016	Conduction (CO05-HY)
Bilog Antenna	TESEQ	CBL 6111D	35419	30MHz to 1GHz	Jan. 13, 2016	Jul. 30, 2016 ~ Jul. 31, 2016	Jan. 12, 2017	Radiation (03CH07-HY)
EMI Test Receiver	Keysight	N9038A(MXE)	MY54130085	20Hz ~ 8.4GHz	Nov. 04, 2015	Jul. 30, 2016 ~ Jul. 31, 2016	Nov. 03, 2016	Radiation (03CH07-HY)
Loop Antenna	Rohde & Schwarz	HFH2-Z2	100315	9 kHz~30 MHz	Sep. 02, 2015	Jul. 30, 2016 ~ Jul. 31, 2016	Sep. 01, 2016	Radiation (03CH07-HY)
Preamplifier	MITEQ	AMF-7D-0010 1800-30-10P	1590075	1GHz ~ 18GHz	Apr. 15, 2016	Jul. 30, 2016 ~ Jul. 31, 2016	Apr. 14, 2017	Radiation (03CH07-HY)
Spectrum Analyzer	Agilent	N9010A	MY53470118	10Hz~44GHz	Feb. 27, 2016	Jul. 30, 2016 ~ Jul. 31, 2016	Feb. 26, 2017	Radiation (03CH07-HY)
Antenna Mast	Max-Full	MFA520BS	N/A	1m~4m	N/A	Jul. 30, 2016 ~ Jul. 31, 2016	N/A	Radiation (03CH07-HY)
Turn Table	ChainTek	Chaintek 3000	N/A	0~360 Degree	N/A	Jul. 30, 2016 ~ Jul. 31, 2016	N/A	Radiation (03CH07-HY)
Preamplifier	COM-POWER	PA-103A	161241	10MHz~1GHz	Mar. 18, 2016	Jul. 30, 2016 ~ Jul. 31, 2016	Mar. 17, 2017	Radiation (03CH07-HY)

Appendix A. Test Results of Conducted Emission Test

<WPC Charging Mode>

Test Mode :	NFC Tx	Test Voltage :	120Vac / 60Hz
Function Type :	GSM850 Idle + Bluetooth Link + WLAN Link + NFC Tx + WPC Back Cover + WPC Charging Pad + USB Cable (Charging from Adapter)		

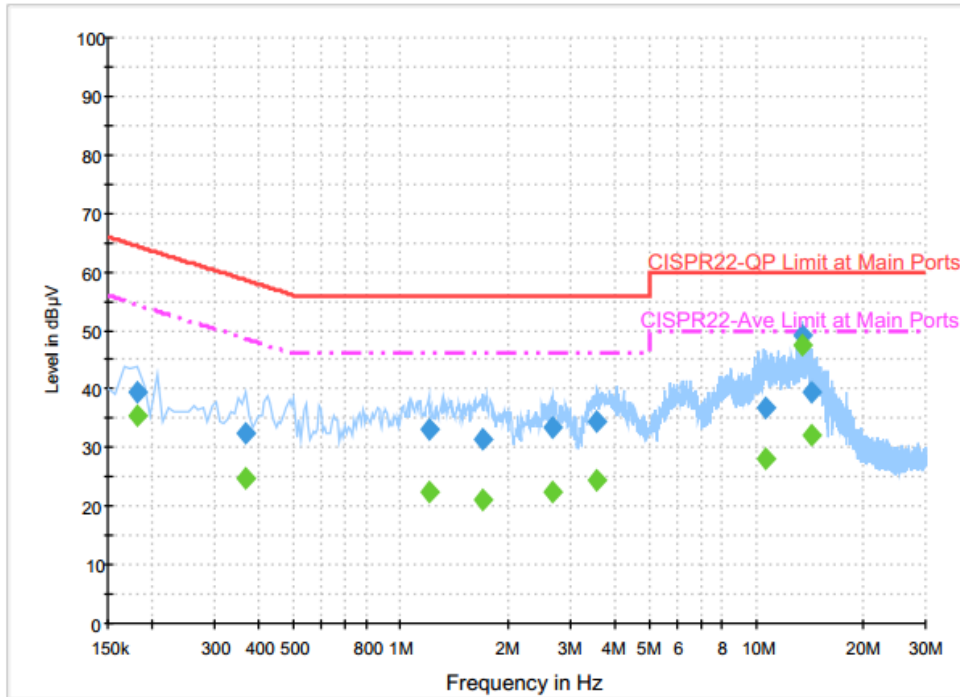

Final Result : Quasi-Peak

Frequency (MHz)	Quasi-Peak (dBµV)	Filter	Line	Corr. (dB)	Margin (dB)	Limit (dBµV)
0.182000	39.6	Off	L1	19.6	24.8	64.4
0.366000	32.3	Off	L1	19.6	26.3	58.6
1.198000	33.1	Off	L1	19.7	22.9	56.0
1.702000	31.4	Off	L1	19.7	24.6	56.0
2.662000	33.3	Off	L1	19.4	22.7	56.0
3.574000	34.6	Off	L1	19.8	21.4	56.0
10.646000	36.9	Off	L1	20.2	23.1	60.0
13.558000	49.1	Off	L1	20.3	10.9	60.0
14.310000	39.4	Off	L1	20.4	20.6	60.0



Test Mode :	NFC Tx	Test Voltage :	120Vac / 60Hz
Function Type :	GSM850 Idle + Bluetooth Link + WLAN Link + NFC Tx + WPC Back Cover + WPC Charging Pad + USB Cable (Charging from Adapter)		

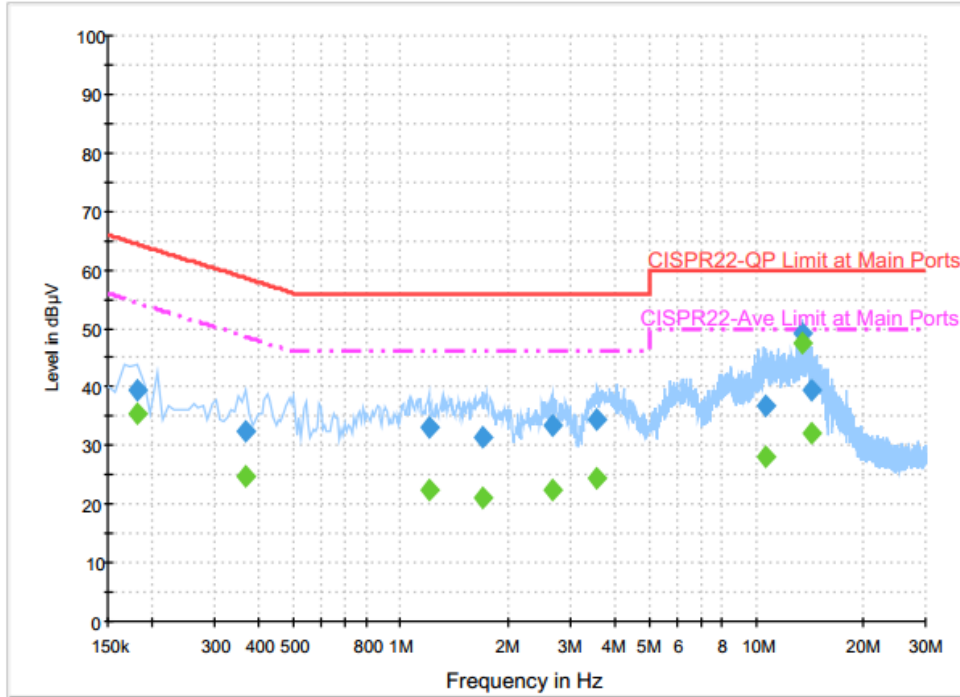

Final Result : Average

Frequency (MHz)	Average (dBµV)	Filter	Line	Corr. (dB)	Margin (dB)	Limit (dBµV)
0.182000	35.5	Off	L1	19.6	18.9	54.4
0.366000	24.9	Off	L1	19.6	23.7	48.6
1.198000	22.5	Off	L1	19.7	23.5	46.0
1.702000	21.2	Off	L1	19.7	24.8	46.0
2.662000	22.3	Off	L1	19.4	23.7	46.0
3.574000	24.4	Off	L1	19.8	21.6	46.0
10.646000	28.1	Off	L1	20.2	21.9	50.0
13.558000	47.6	Off	L1	20.3	2.4	50.0
14.310000	32.2	Off	L1	20.4	17.8	50.0



Test Mode :	NFC Tx	Test Voltage :	120Vac / 60Hz
Function Type :	GSM850 Idle + Bluetooth Link + WLAN Link + NFC Tx + WPC Back Cover + WPC Charging Pad + USB Cable (Charging from Adapter)		

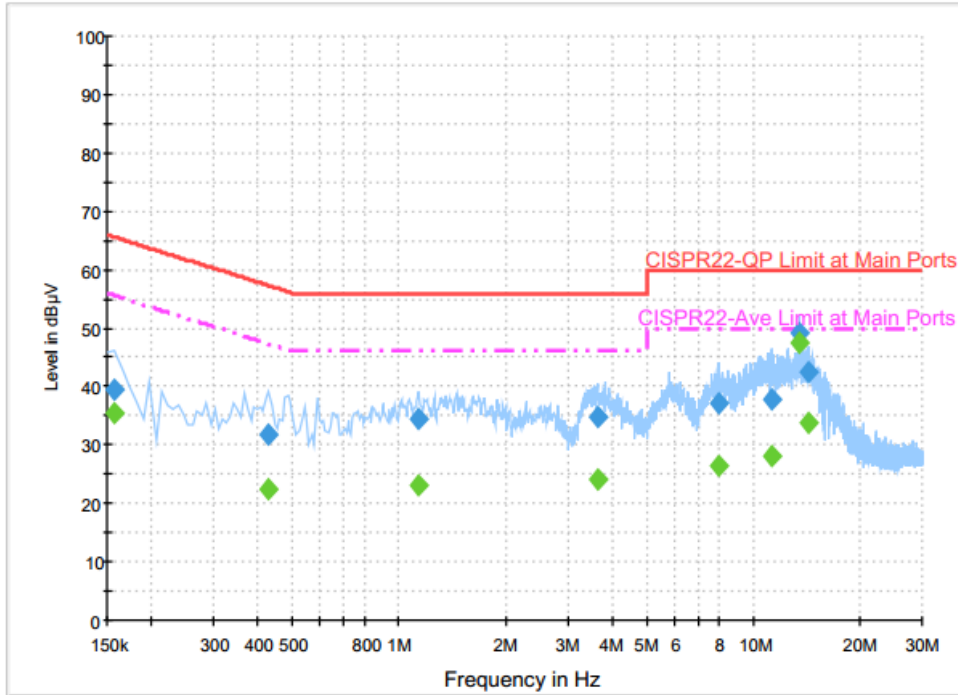

Final Result : Quasi-Peak

Frequency (MHz)	Quasi-Peak (dBµV)	Filter	Line	Corr. (dB)	Margin (dB)	Limit (dBµV)
0.158000	39.3	Off	N	19.6	26.3	65.6
0.430000	31.8	Off	N	19.6	25.5	57.3
1.142000	34.6	Off	N	19.6	21.4	56.0
3.630000	34.9	Off	N	19.7	21.1	56.0
7.982000	37.2	Off	N	20.0	22.8	60.0
11.310000	37.6	Off	N	20.2	22.4	60.0
13.558000	49.1	Off	N	20.4	10.9	60.0
14.286000	42.5	Off	N	20.4	17.5	60.0



Test Mode :	NFC Tx	Test Voltage :	120Vac / 60Hz
Function Type :	GSM850 Idle + Bluetooth Link + WLAN Link + NFC Tx + WPC Back Cover + WPC Charging Pad + USB Cable (Charging from Adapter)		

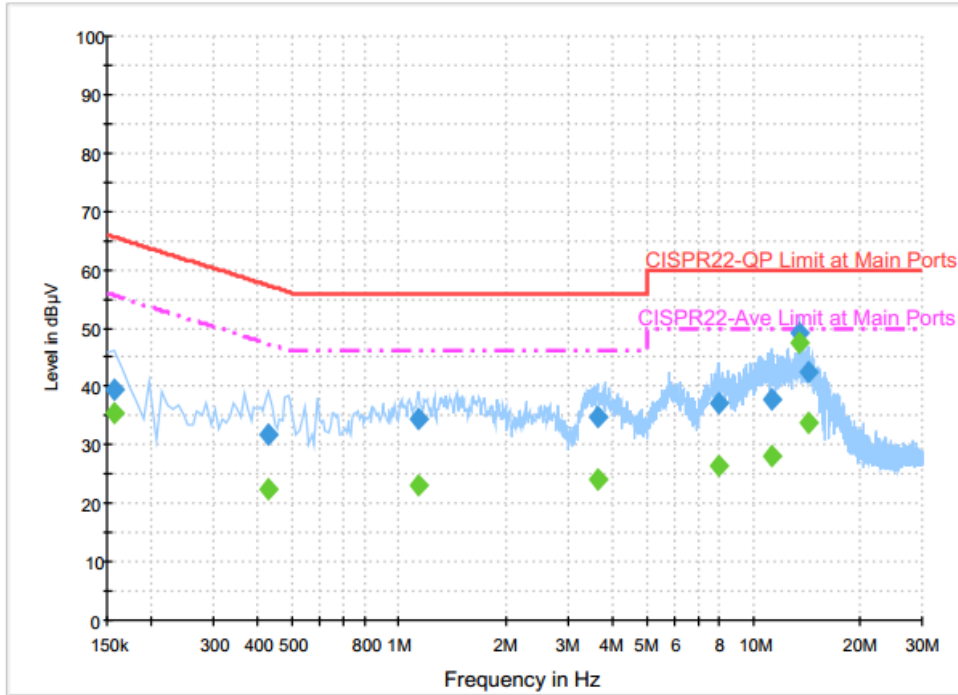

Final Result : Average

Frequency (MHz)	Average (dBµV)	Filter	Line	Corr. (dB)	Margin (dB)	Limit (dBµV)
0.158000	35.5	Off	N	19.6	20.1	55.6
0.430000	22.4	Off	N	19.6	24.9	47.3
1.142000	23.2	Off	N	19.6	22.8	46.0
3.630000	24.1	Off	N	19.7	21.9	46.0
7.982000	26.5	Off	N	20.0	23.5	50.0
11.310000	28.2	Off	N	20.2	21.8	50.0
13.558000	47.4	Off	N	20.4	2.6	50.0
14.286000	33.8	Off	N	20.4	16.2	50.0



<PMA Charging Mode>

Test Mode :	NFC Tx	Test Voltage :	120Vac / 60Hz
Function Type :	GSM850 Idle + Bluetooth Link + WLAN Link + NFC Tx + WPC Back cover + PMA Charging Pad + Adapter		

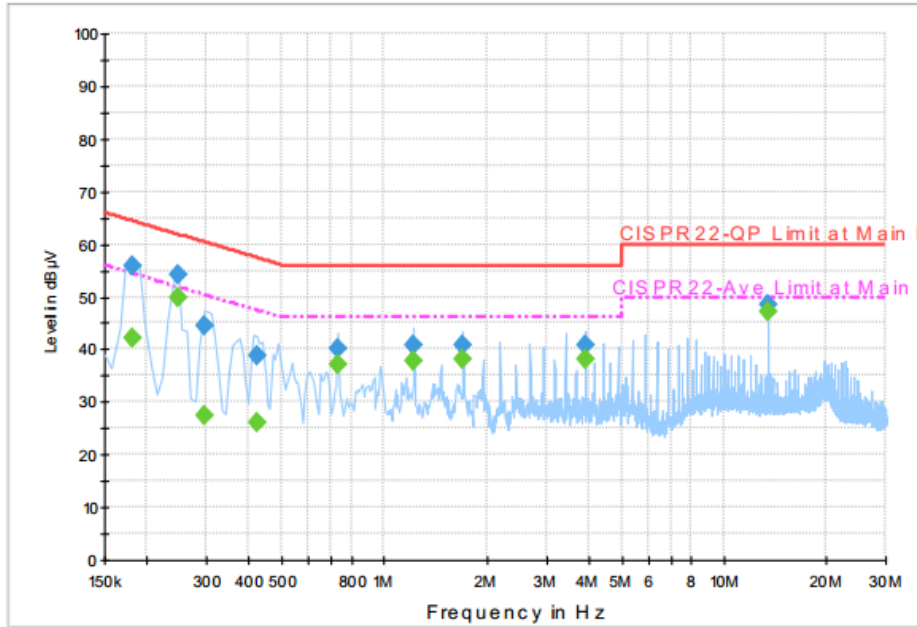

Final Result : Quasi-Peak

Frequency (MHz)	Quasi-Peak (dBµV)	Filter	Line	Corr. (dB)	Margin (dB)	Limit (dBµV)
0.182000	55.9	Off	L1	19.6	8.5	64.4
0.246000	54.1	Off	L1	19.6	7.8	61.9
0.294000	44.6	Off	L1	19.6	15.8	60.4
0.422000	38.7	Off	L1	19.6	18.7	57.4
0.734000	40.1	Off	L1	19.6	15.9	56.0
1.222000	40.6	Off	L1	19.7	15.4	56.0
1.710000	40.8	Off	L1	19.7	15.2	56.0
3.910000	40.8	Off	L1	19.8	15.2	56.0
13.558000	48.5	Off	L1	20.3	11.5	60.0



Test Mode :	NFC Tx	Test Voltage :	120Vac / 60Hz
Function Type :	GSM850 Idle + Bluetooth Link + WLAN Link + NFC Tx + WPC Back cover + PMA Charging Pad + Adapter		

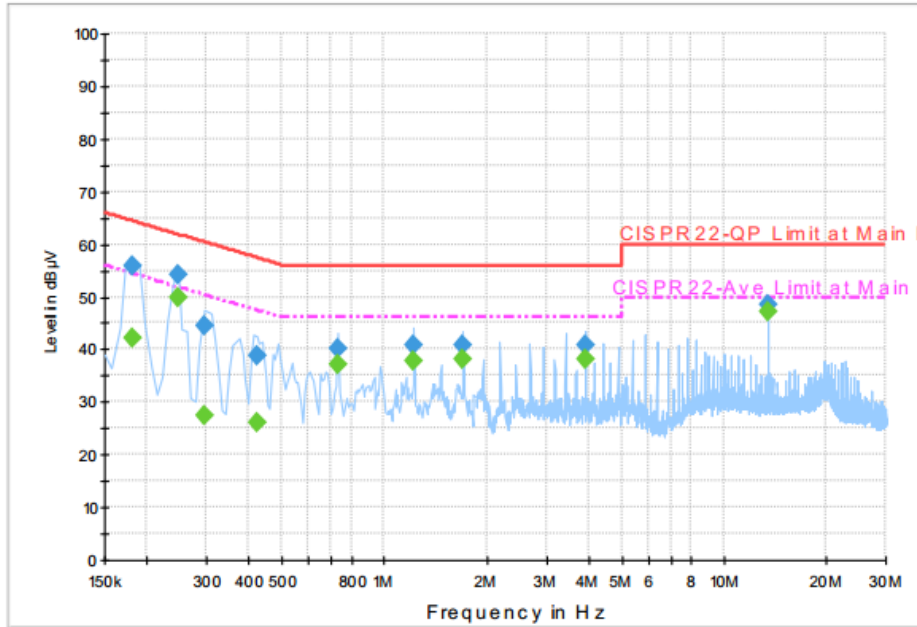

Final Result : Average

Frequency (MHz)	Average (dBµV)	Filter	Line	Corr. (dB)	Margin (dB)	Limit (dBµV)
0.182000	42.0	Off	L1	19.6	12.4	54.4
0.246000	49.8	Off	L1	19.6	2.1	51.9
0.294000	27.3	Off	L1	19.6	23.1	50.4
0.422000	25.9	Off	L1	19.6	21.5	47.4
0.734000	37.0	Off	L1	19.6	9.0	46.0
1.222000	37.8	Off	L1	19.7	8.2	46.0
1.710000	38.0	Off	L1	19.7	8.0	46.0
3.910000	38.3	Off	L1	19.8	7.7	46.0
13.558000	47.3	Off	L1	20.3	2.7	50.0



Test Mode :	NFC Tx	Test Voltage :	120Vac / 60Hz
Function Type :	GSM850 Idle + Bluetooth Link + WLAN Link + NFC Tx + WPC Back cover + PMA Charging Pad + Adapter		

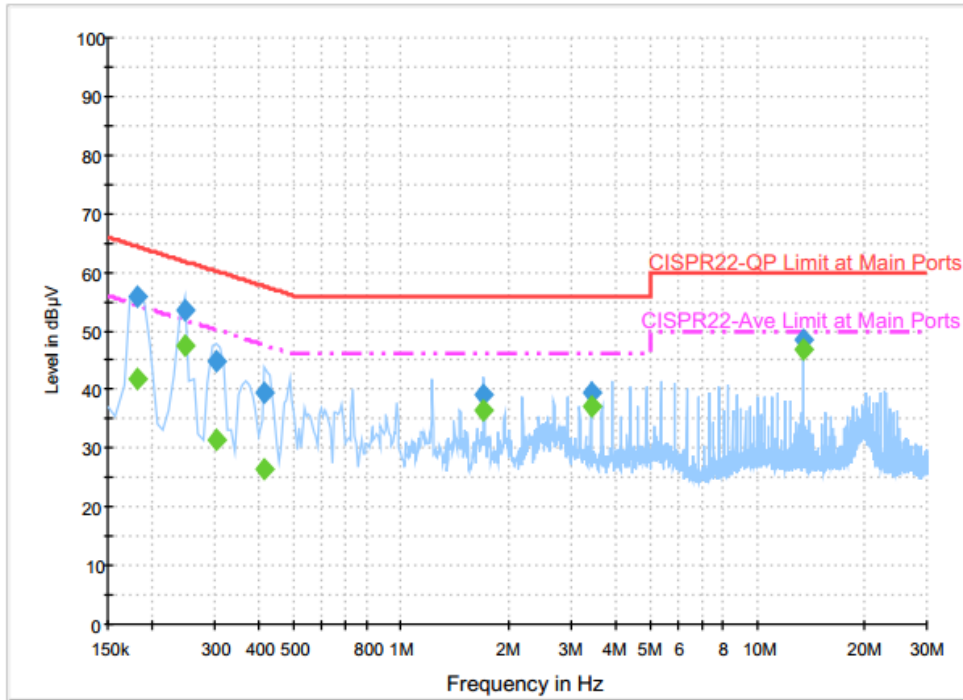

Final Result : Quasi-Peak

Frequency (MHz)	Quasi-Peak (dBµV)	Filter	Line	Corr. (dB)	Margin (dB)	Limit (dBµV)
0.182000	55.8	Off	N	19.6	8.6	64.4
0.246000	53.4	Off	N	19.6	8.5	61.9
0.302000	44.8	Off	N	19.6	15.4	60.2
0.414000	39.6	Off	N	19.6	18.0	57.6
1.710000	39.1	Off	N	19.7	16.9	56.0
3.422000	39.5	Off	N	19.7	16.5	56.0
13.558000	48.6	Off	N	20.4	11.4	60.0



Test Mode :	NFC Tx	Test Voltage :	120Vac / 60Hz
Function Type :	GSM850 Idle + Bluetooth Link + WLAN Link + NFC Tx + WPC Back cover + PMA Charging Pad + Adapter		

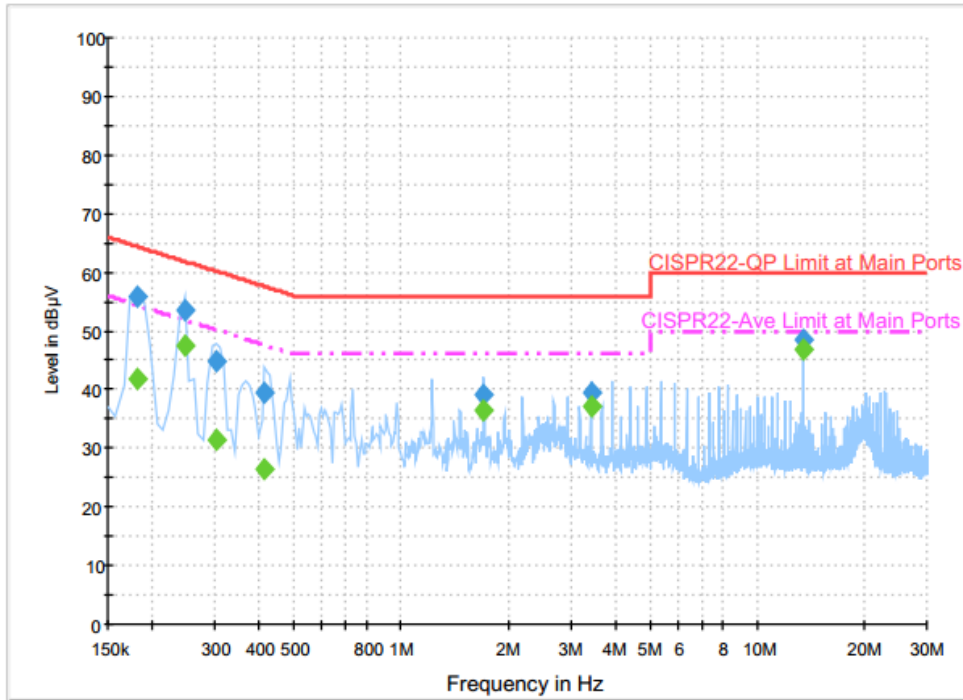

Final Result : Average

Frequency (MHz)	Average (dBµV)	Filter	Line	Corr. (dB)	Margin (dB)	Limit (dBµV)
0.182000	41.9	Off	N	19.6	12.5	54.4
0.246000	47.5	Off	N	19.6	4.4	51.9
0.302000	31.5	Off	N	19.6	18.7	50.2
0.414000	26.4	Off	N	19.6	21.2	47.6
1.710000	36.6	Off	N	19.7	9.4	46.0
3.422000	37.0	Off	N	19.7	9.0	46.0
13.558000	46.7	Off	N	20.4	3.3	50.0

(1) with antenna

Remark: 13.558MHz is the NFC RF fundamental signal.

(2) with dummy load

Remark: Only the fundamental NFC signal needs to be retested per C63.4.



Appendix B. Test Results of Radiated Test Items

B.1 Test Result of Field Strength of Fundamental Emissions

<WPC Charging Mode>

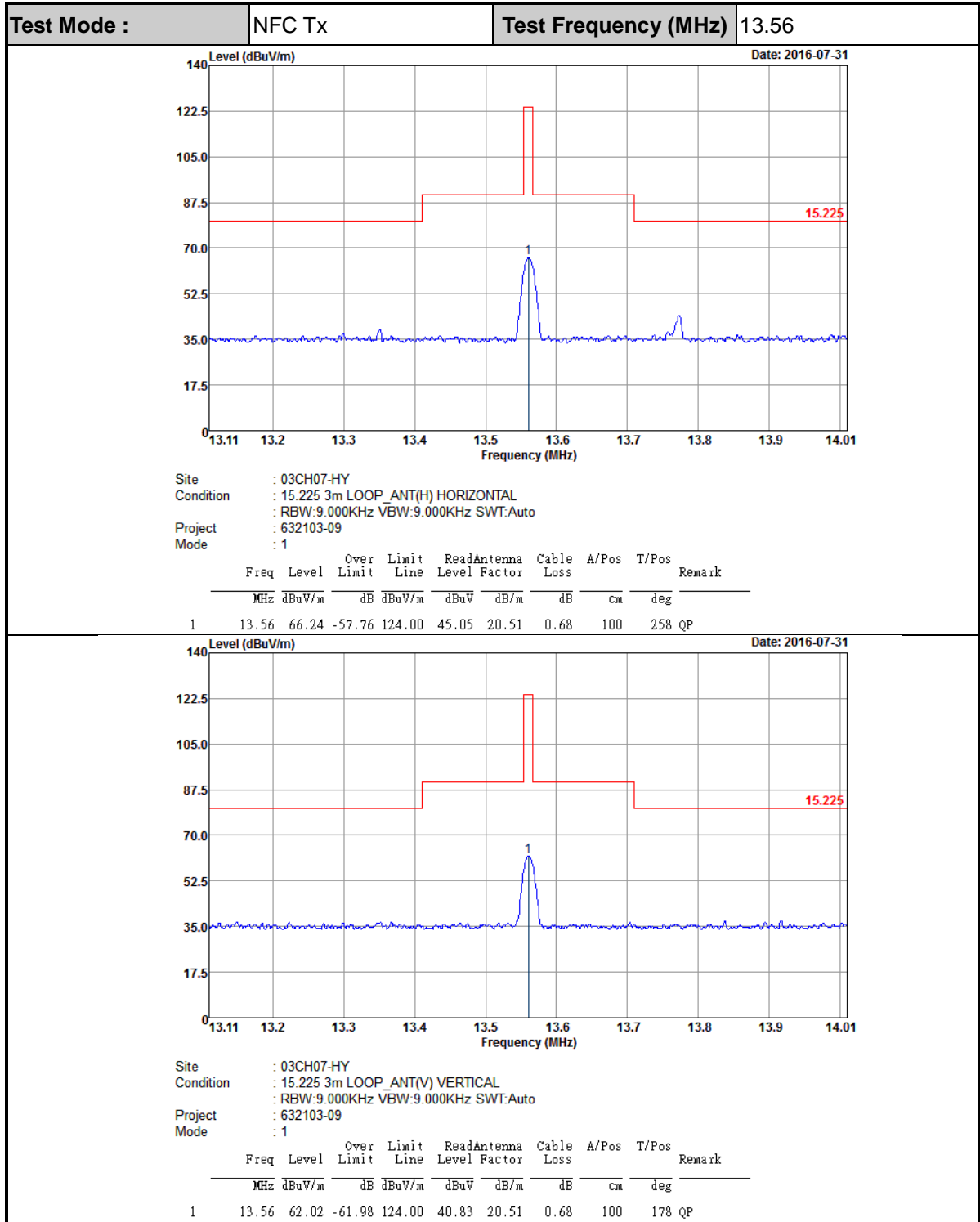

Note: All NFC's spurious emissions are below 20dB of limits.



<PMA Charging Mode>

Test Mode :	NFC Tx	Test Frequency (MHz)	13.56
-------------	--------	----------------------	-------

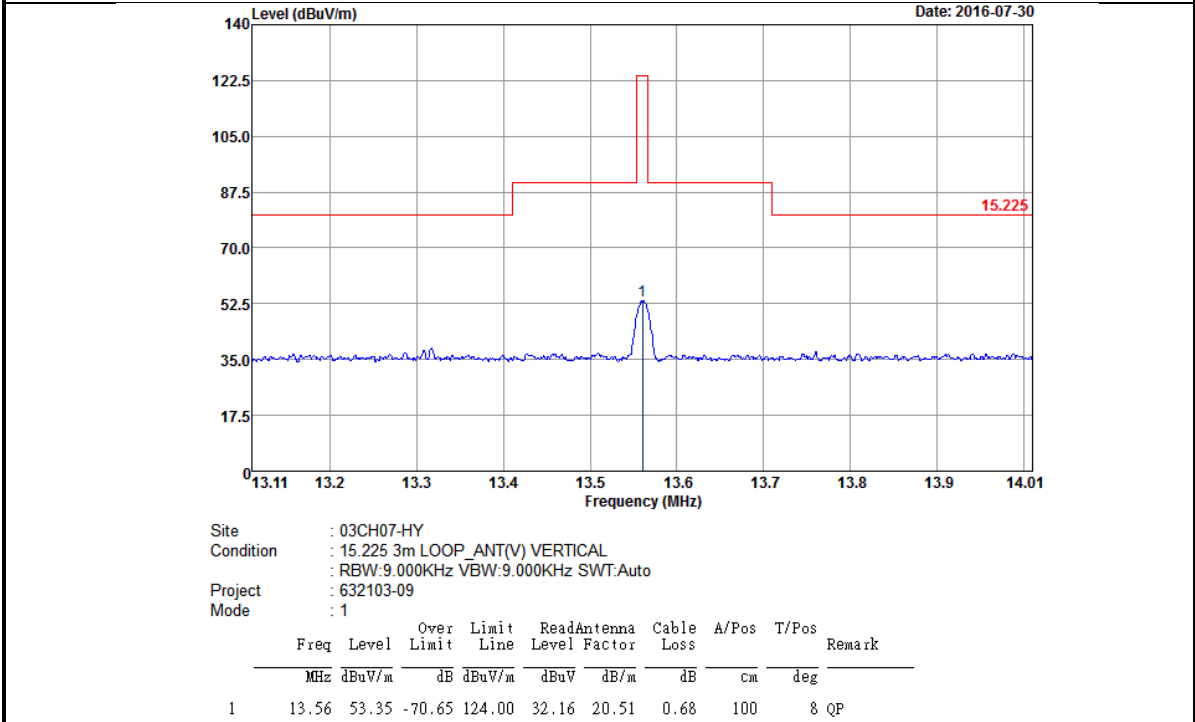
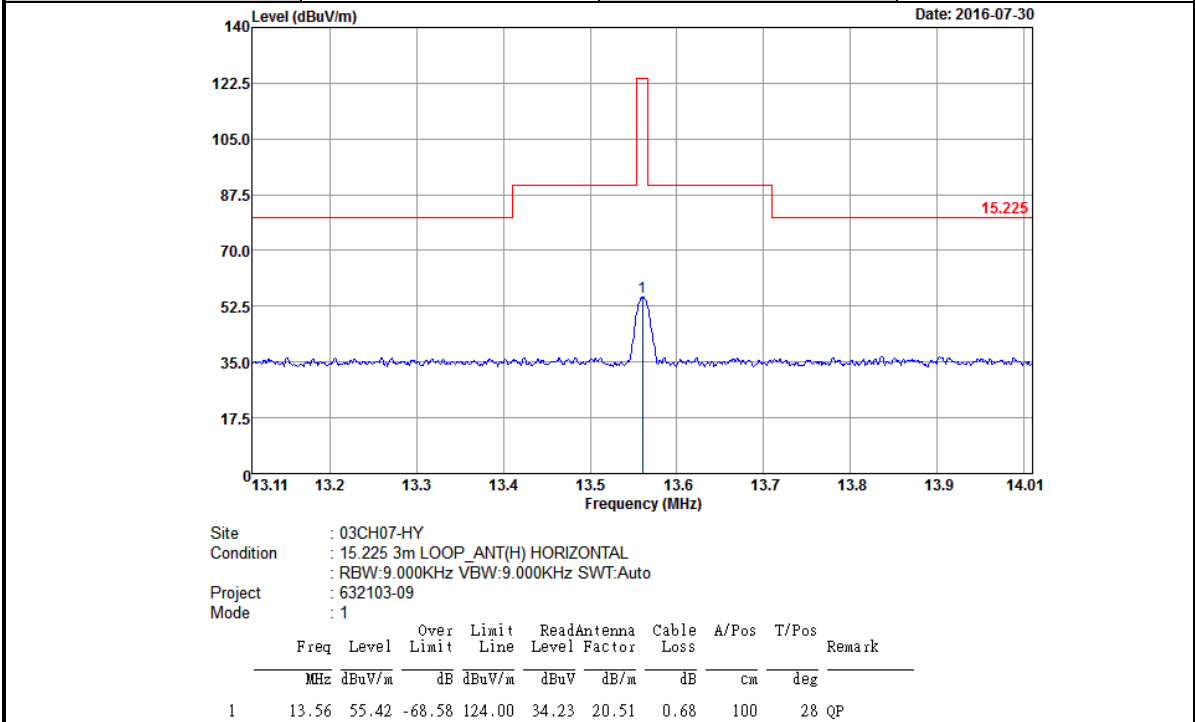

Note: All NFC's spurious emissions are below 20dB of limits.



B.2 Results of Radiated Emissions (9 kHz~30MHz)

<WPC Charging Mode>

Test Mode :	NFC Tx	Polarization :	Horizontal
--------------------	--------	-----------------------	------------

Frequency (MHz)	Level (dBµV/m)	Over Limit (dB)	Limit Line (dBµV/m)	Read Level (dBµV)	Antenna Factor (dB)	Cable Loss (dB)	Ant Pos (cm)	Table Pos (deg)	Remark
0.01313	58.39	-66.85	125.24	34.81	22.9	0.68	-	-	Average
0.06945	60.88	-49.89	110.77	41.2	19	0.68	-	-	Average
0.10162	47.63	-59.83	107.46	28.15	18.8	0.68	-	-	QP
0.129	52.76	-52.63	105.39	33.29	18.79	0.68	-	-	Average
0.17448	60.77	-42	102.77	41.33	18.76	0.68	-	-	Average
0.52755	50.87	-22.29	73.16	31.57	18.62	0.68	100	0	QP
12.664	37.28	-32.22	69.5	16.27	20.33	0.68	-	-	QP
13.56	65.34	-4.16	69.5	44.15	20.51	0.68	-	-	QP
20.689	38.72	-30.78	69.5	15.81	21.84	1.07	-	-	QP
29.48	39.3	-30.2	69.5	15.86	22.37	1.07	-	-	QP

Test Mode :	NFC Tx	Polarization :	Vertical
--------------------	--------	-----------------------	----------

Frequency (MHz)	Level (dBµV/m)	Over Limit (dB)	Limit Line (dBµV/m)	Read Level (dBµV)	Antenna Factor (dB)	Cable Loss (dB)	Ant Pos (cm)	Table Pos (deg)	Remark
0.0421	51.61	-63.51	115.12	31.73	19.2	0.68	-	-	Average
0.0645	42.37	-69.04	111.41	22.69	19	0.68	-	-	Average
0.10142	43.13	-64.35	107.48	23.65	18.8	0.68	-	-	QP
0.14248	39.1	-65.43	104.53	19.63	18.79	0.68	-	-	Average
0.1755	56.29	-46.43	102.72	36.85	18.76	0.68	-	-	Average
0.49	51.68	-22.12	73.8	32.4	18.6	0.68	100	0	QP
10.248	36.56	-32.94	69.5	16.03	19.85	0.68	-	-	QP
13.56	60.92	-8.58	69.5	39.73	20.51	0.68	-	-	QP
23.263	39.65	-29.85	69.5	16.59	21.99	1.07	-	-	QP
25.665	39.51	-29.99	69.5	16.3	22.14	1.07	-	-	QP

Note:

1. 13.56 MHz is fundamental signal which can be ignored.
2. The amplitude of spurious emissions which are attenuated by more than 20dB below the permissible value has no need to be reported.
3. Distance extrapolation factor = 40 log (specific distance / test distance) (dB);
4. Limit line = specific limits (dBµV) + distance extrapolation factor.



<PMA Charging Mode>

Test Mode :	NFC Tx	Polarization :	Horizontal
-------------	--------	----------------	------------

Frequency (MHz)	Level (dBμV/m)	Over Limit (dB)	Limit Line (dBμV/m)	Read Level (dBμV)	Antenna Factor (dB)	Cable Loss (dB)	Ant Pos (cm)	Table Pos (deg)	Remark
0.03761	52.94	-63.16	116.1	33.06	19.2	0.68	-	-	Average
0.06945	48.63	-62.14	110.77	28.95	19	0.68	-	-	Average
0.09368	47	-61.17	108.17	27.52	18.8	0.68	-	-	QP
0.129	50.5	-54.89	105.39	31.03	18.79	0.68	-	-	Average
0.25608	50.73	-48.71	99.44	31.32	18.73	0.68	-	-	Average
0.51253	51.95	-21.46	73.41	32.65	18.62	0.68	100	0	QP
9.984	34.63	-34.87	69.5	14.15	19.8	0.68	-	-	QP
13.56	54.98	-14.52	69.5	33.79	20.51	0.68	-	-	QP
22.561	38.94	-30.56	69.5	15.92	21.95	1.07	-	-	QP
25.255	39.39	-30.11	69.5	16.2	22.12	1.07	-	-	QP

Test Mode :	NFC Tx	Polarization :	Vertical
-------------	--------	----------------	----------

Frequency (MHz)	Level (dBμV/m)	Over Limit (dB)	Limit Line (dBμV/m)	Read Level (dBμV)	Antenna Factor (dB)	Cable Loss (dB)	Ant Pos (cm)	Table Pos (deg)	Remark
0.0525	48.89	-64.31	113.2	29.01	19.2	0.68	-	-	Average
0.08409	50.01	-59.1	109.11	30.53	18.8	0.68	-	-	Average
0.0908	50.69	-57.75	108.44	31.21	18.8	0.68	-	-	QP
0.12892	43.18	-62.22	105.4	23.71	18.79	0.68	-	-	Average
0.26424	48.88	-50.28	99.16	29.49	18.71	0.68	-	-	Average
0.49751	51.28	-22.39	73.67	32	18.6	0.68	100	0	QP
8.728	37.51	-31.99	69.5	17.23	19.6	0.68	-	-	QP
13.56	52.97	-16.53	69.5	31.78	20.51	0.68	-	-	QP
22.003	39.81	-29.69	69.5	16.82	21.92	1.07	-	-	QP
28.195	39.18	-30.32	69.5	15.82	22.29	1.07	-	-	QP

Note:

1. 13.56 MHz is fundamental signal which can be ignored.
2. The amplitude of spurious emissions which are attenuated by more than 20dB below the permissible value has no need to be reported.
3. Distance extrapolation factor = 40 log (specific distance / test distance) (dB);
4. Limit line = specific limits (dBμV) + distance extrapolation factor.



B.3 Results of Radiated Emissions (30MHz~1GHz)

<WPC Charging Mode>

Test Mode :	NFC Tx	Polarization :	Horizontal
-------------	--------	----------------	------------

Frequency (MHz)	Level (dBμV/m)	Over Limit (dB)	Limit Line (dBμV/m)	Read Level (dBμV)	Antenna Factor (dB)	Cable Loss (dB)	Preamp Factor (dB)	Ant Pos (cm)	Table Pos (deg)	Remark
55.38	26.44	-13.56	40	43.41	13.55	1.07	31.59	100	29	Peak
180.93	29.79	-13.71	43.5	44	15.41	1.87	31.49	-	-	Peak
261.12	24.44	-21.56	46	33.53	19.94	2.32	31.35	-	-	Peak
454	25.7	-20.3	46	30.72	23.18	2.89	31.09	-	-	Peak
729.1	29.66	-16.34	46	29.73	26.87	3.74	30.68	-	-	Peak
999.3	33.72	-20.28	54	29.96	30.3	3.98	30.52	-	-	Peak

Test Mode :	NFC Tx	Polarization :	Vertical
-------------	--------	----------------	----------

Frequency (MHz)	Level (dBμV/m)	Over Limit (dB)	Limit Line (dBμV/m)	Read Level (dBμV)	Antenna Factor (dB)	Cable Loss (dB)	Preamp Factor (dB)	Ant Pos (cm)	Table Pos (deg)	Remark
52.95	33.72	-6.28	40	50.08	14.17	1.07	31.6	100	299	Peak
92.1	29.86	-13.64	43.5	44.75	15.36	1.28	31.53	-	-	Peak
205.23	26.79	-16.71	43.5	40.23	16.16	1.87	31.47	-	-	Peak
477.1	25.88	-20.12	46	30.2	23.69	3.04	31.05	-	-	Peak
771.8	30.34	-15.66	46	29.73	27.42	3.82	30.63	-	-	Peak
972.7	34.32	-19.68	54	30.53	30.25	4.07	30.53	-	-	Peak

Note:

1. The amplitude of spurious emissions which are attenuated by more than 20dB below the permissible value has no need to be reported.
2. Emission level (dBμV/m) = 20 log Emission level (μV/m).
3. Corrected Reading: Antenna Factor + Cable Loss + Read Level - Preamp Factor= Level.



<PMA Charging Mode>

Test Mode :	NFC Tx	Polarization :	Horizontal
-------------	--------	----------------	------------

Frequency (MHz)	Level (dBµV/m)	Over Limit (dB)	Limit Line (dBµV/m)	Read Level (dBµV)	Antenna Factor (dB)	Cable Loss (dB)	Preamp Factor (dB)	Ant Pos (cm)	Table Pos (deg)	Remark
30.27	28.81	-11.19	40	33.09	26	1.07	31.35	100	277	Peak
149.07	28.88	-14.62	43.5	40.87	17.73	1.78	31.5	-	-	Peak
268.68	21.47	-24.53	46	31.03	19.46	2.32	31.34	-	-	Peak
546.4	27.69	-18.31	46	30.81	24.57	3.24	30.93	-	-	Peak
848.1	32.8	-13.2	46	30.61	28.66	4.1	30.57	-	-	Peak
934.9	33.83	-12.17	46	30.39	29.85	4.12	30.53	-	-	Peak

Test Mode :	NFC Tx	Polarization :	Vertical
-------------	--------	----------------	----------

Frequency (MHz)	Level (dBµV/m)	Over Limit (dB)	Limit Line (dBµV/m)	Read Level (dBµV)	Antenna Factor (dB)	Cable Loss (dB)	Preamp Factor (dB)	Ant Pos (cm)	Table Pos (deg)	Remark
40.8	29.77	-10.23	40	40.35	19.84	1.07	31.49	100	22	Peak
149.07	27.07	-16.43	43.5	39.06	17.73	1.78	31.5	-	-	Peak
258.96	21.86	-24.14	46	31.25	19.9	2.07	31.36	-	-	Peak
420.4	28.56	-17.44	46	34.13	22.68	2.89	31.14	-	-	Peak
812.4	31.37	-14.63	46	30.1	27.95	3.9	30.58	-	-	Peak
991.6	34.29	-19.71	54	30.55	30.28	3.98	30.52	-	-	Peak

Note:

1. The amplitude of spurious emissions which are attenuated by more than 20dB below the permissible value has no need to be reported.
2. Emission level (dBµV/m) = 20 log Emission level (µV/m).
3. Corrected Reading: Antenna Factor + Cable Loss + Read Level - Preamp Factor= Level.



Appendix C. Original Report

Please refer to Sporton report number FR632103F as below.



FCC RF Test Report

APPLICANT : Motorola Mobility, LLC
EQUIPMENT : Mobile Cellular Phone
BRAND NAME : Motorola
MODEL NAME : 6576
FCC ID : IHDT56VB4
STANDARD : FCC Part 15 Subpart C §15.225
CLASSIFICATION : (DXX) Low Power Communication Device Transmitter

This is a variant report which is only valid together with the original test report. The product was received on Mar. 21, 2016. We, SPORTON INTERNATIONAL INC., would like to declare that the tested sample has been evaluated in accordance with the test procedures and has been in compliance with the applicable technical standards.

The test results in this report apply exclusively to the tested model / sample. Without written approval of SPORTON INTERNATIONAL INC., the test report shall not be reproduced except in full.

Reviewed by: Joseph Lin / Supervisor

Approved by: Jones Tsai / Manager



SPORTON INTERNATIONAL INC.

No. 52, Hwa Ya 1st Rd., Hwa Ya Technology Park, Kwei-Shan District, Tao Yuan City, Taiwan, R.O.C.



Table of Contents

1. GENERAL INFORMATION.....4

1.1 Applicant..... 4

1.2 Manufacturer..... 4

1.3 Feature of Equipment Under Test 4

1.4 Re-use of Measured Data 5

1.4.1 Introduction Section 5

1.4.2 Difference Section 5

1.4.3 Spot Check Verification Data Section 5

1.4.4 Reference detail Section: 5

1.5 Modification of EUT 5

APPENDIX A. ORIGINAL REPORT



1. GENERAL INFORMATION

1.1 Applicant

Motorola Mobility, LLC

222 W Merchandise Mart Plaza, Suite 1800, Chicago, IL 60654, United States

1.2 Manufacturer

Motorola Mobility, LLC

222 W Merchandise Mart Plaza, Suite 1800, Chicago, IL 60654, United States

1.3 Feature of Equipment Under Test

Product Feature	
Equipment	Mobile Cellular Phone
Brand Name	Motorola
Model Name	6576
FCC ID	IHDT56VB4
EUT supports Radios application	GSM/EGPRS/WCDMA/HSPA/LTE/NFC 2.4GHz WLAN 11b/g/n HT20 WLAN 11ac VHT20 5GHz WLAN 11a/n HT20/HT40 WLAN 11ac VHT20/VHT40/VHT80 Bluetooth v3.0 EDR Bluetooth v4.2 - LE
HW Version	DVT2
EUT Stage	Identical Prototype



1.4 Re-use of Measured Data

1.4.1 Introduction Section

This application re-uses data collected on a similar device. The subject device of this application (Model 6576, FCC ID IHDT56VB4) is electrically identical to the reference device (Model 4237, FCC ID IHDT56VB1) for the portions of the circuitry corresponding to the data being re-used, as treated by KDB Publication 178919 D01.

1.4.2 Difference Section

For details concerning the similarity with respect to component placement, mechanical/electrical design etc., please refer to the Operational Description.

The re-used RF data includes the following bands provided in Appendix A (Sporton RF Report No. FR631828F for the reference device Model 4237, FCC ID IHDT56VB1):

- NFC

1.4.3 Spot Check Verification Data Section

In order to confirm hardware similarity of the subject device with the reference device, spot check measurements were performed on the subject device for radiated spurious emission, the test result were consistent with FCC ID IHDT56VB1.

Assertions concerning the similarity of these devices are based on representations by the applicant. The applicant accepts full responsibility for the validity of the similarity claim, and for the determination that verification test data are sufficient to support it.

1.4.4 Reference detail Section:

Equipment Class	Reference FCC ID	Folder Test/RF Exposure	Report Title/Section
DXX	IHDT56VB1	Part15C (FR631828F)	All sections applicable

1.5 Modification of EUT

No modifications are made to the EUT during all test items.



Appendix A. Original Report

Please refer to Sporton report number FR631828F.