



# FCC RF Test Report

APPLICANT : Motorola Mobility, LLC  
EQUIPMENT : Mobile Cellular Phone  
BRAND NAME : Motorola  
MODEL NAME : 6576  
FCC ID : IHDT56VB4  
STANDARD : FCC Part 15 Subpart C §15.247  
CLASSIFICATION : (DTS) Digital Transmission System

The product was received on Jul. 28, 2016 and testing was completed on Aug. 03, 2016. We, SPORTON INTERNATIONAL INC., would like to declare that the tested sample has been evaluated in accordance with the test procedures and has been in compliance with the applicable technical standards.

The test results in this report apply exclusively to the tested model / sample. Without written approval of SPORTON INTERNATIONAL INC., the test report shall not be reproduced except in full.

Reviewed by: Joseph Lin / Supervisor

Approved by: Jones Tsai / Manager



## SPORTON INTERNATIONAL INC.

No. 52, Hwa Ya 1<sup>st</sup> Rd., Hwa Ya Technology Park, Kwei-Shan District, Tao Yuan City, Taiwan, R.O.C.



# TABLE OF CONTENTS

**REVISION HISTORY..... 3**

**SUMMARY OF TEST RESULT ..... 4**

**1 GENERAL DESCRIPTION ..... 5**

    1.1 Applicant ..... 5

    1.2 Manufacturer ..... 5

    1.3 Product Feature of Equipment Under Test..... 5

    1.4 Product Specification of Equipment Under Test..... 6

    1.5 Modification of EUT ..... 6

    1.6 Testing Location ..... 6

    1.7 Applicable Standards..... 7

**2 TEST CONFIGURATION OF EQUIPMENT UNDER TEST ..... 8**

    2.1 Carrier Frequency Channel ..... 8

    2.2 Test Mode..... 8

    2.3 Connection Diagram of Test System..... 9

    2.4 Support Unit used in test configuration and system ..... 11

    2.5 EUT Operation Test Setup ..... 11

**3 TEST RESULT ..... 12**

    3.1 Radiated Band Edges and Spurious Emission Measurement ..... 12

    3.2 AC Conducted Emission Measurement..... 16

**4 LIST OF MEASURING EQUIPMENT ..... 20**

**5 UNCERTAINTY OF EVALUATION ..... 21**

**APPENDIX A. RADIATED TEST RESULTS**

**APPENDIX B. RADIATED SPURIOUS EMISSION PLOTS**

**APPENDIX C. DUTY CYCLE PLOTS**

**APPENDIX D. ORIGINAL REPORT**





### SUMMARY OF TEST RESULT

Report Section	FCC Rule	Description	Limit	Result	Remark
3.1	15.247(d)	Radiated Band Edges and Radiated Spurious Emission	15.209(a) & 15.247(d)	Pass	Under limit 4.35 dB at 41.070 MHz
3.2	15.207	AC Conducted Emission	15.207(a)	Pass	Under limit 2.20 dB at 0.246 MHz



# 1 General Description

## 1.1 Applicant

**Motorola Mobility, LLC**

222 W Merchandise Mart Plaza, Suite 1800, Chicago, IL 60654, United States

## 1.2 Manufacturer

**Motorola Mobility, LLC**

222 W Merchandise Mart Plaza, Suite 1800, Chicago, IL 60654, United States

## 1.3 Product Feature of Equipment Under Test

Product Feature	
<b>Equipment</b>	Mobile Cellular Phone
<b>Brand Name</b>	Motorola
<b>Model Name</b>	6576
<b>FCC ID</b>	IHDT56VB4
<b>IMEI Code</b>	358180070002207 (for Radiation) 358180070002314 (for Conduction)
<b>EUT supports Radios application</b>	CDMA/EV-DO/GSM/EGPRS/WCDMA/HSPA/LTE/NFC  2.4GHz WLAN 11b/g/n HT20 WLAN 11ac VHT20  5GHz WLAN 11a/n HT20/HT40 WLAN 11ac VHT20/VHT40/VHT80  Bluetooth v3.0 EDR Bluetooth v4.2 LE
<b>HW Version</b>	DVT2
<b>EUT Stage</b>	Identical Prototype

**Remark:** The above EUT's information was declared by manufacturer. Please refer to the specifications or user's manual for more detailed description.

Accessory List	
<b>WPC Cover</b>	Brand Name : INCIPIO
	Model Name : MT-043-CASE



### 1.4 Product Specification of Equipment Under Test

Standards-related Product Specification	
<b>Tx/Rx Channel Frequency Range</b>	2412 MHz ~ 2462 MHz
<b>Antenna Type</b>	Fixed Internal Antenna (The antenna peak gain of EUT is less than 6 dBi)
<b>Type of Modulation</b>	802.11b : DSSS (DBPSK / DQPSK / CCK) 802.11g/n : OFDM (BPSK / QPSK / 16QAM / 64QAM) 802.11ac : OFDM (BPSK / QPSK / 16QAM / 64QAM / 256QAM)

### 1.5 Modification of EUT

No modifications are made to the EUT during all test items.

### 1.6 Testing Location

Sporton Lab is accredited to ISO 17025 by Taiwan Accreditation Foundation (TAF code : 1190) and the FCC designation No. TW1022 under the FCC 2.948(e) by Mutual Recognition Agreement (MRA) in FCC Test.

<b>Test Site</b>	SPORTON INTERNATIONAL INC.
<b>Test Site Location</b>	No. 52, Hwa Ya 1 <sup>st</sup> Rd., Hwa Ya Technology Park, Kwei-Shan District, Tao Yuan City, Taiwan, R.O.C. TEL: +886-3-327-3456 FAX: +886-3-328-4978
<b>Test Site No.</b>	<b>Sporton Site No.</b> CO05-HY

**Note:** The test site complies with ANSI C63.4 2014 requirement.

<b>Test Site</b>	SPORTON INTERNATIONAL INC.
<b>Test Site Location</b>	No.58, Aly. 75, Ln. 564, Wenhua 3rd Rd. Guishan Dist, Taoyuan City, Taiwan (R.O.C.) TEL: +886-3-327-0868 FAX: +886-3-327-0855
<b>Test Site No.</b>	<b>Sporton Site No.</b> 03CH11-HY

**Note:** The test site complies with ANSI C63.4 2014 requirement.



## 1.7 Applicable Standards

According to the specifications of the manufacturer, the EUT must comply with the requirements of the following standards:

- ♦ FCC Part 15 Subpart C §15.247
- ♦ FCC KDB Publication No. 558074 D01 DTS Meas. Guidance v03r05
- ♦ FCC KDB 662911 D01 Multiple Transmitter Output v02r01.
- ♦ FCC KDB 644545 D03 Guidance for IEEE 802 11ac New Rules v01
- ♦ KDB 648474 D03 Handset Wireless Chargers Battery Covers v01r04
- ♦ ANSI C63.10-2013

### **Remark:**

1. All test items were verified and recorded according to the standards and without any deviation during the test.
2. This EUT has also been tested and complied with the requirements of FCC Part 15, Subpart B, recorded in a separate test report.



## 2 Test Configuration of Equipment Under Test

The EUT has been associated with peripherals and configuration operated in a manner tended to maximize its emission characteristics in a typical application. Frequency range investigated: conducted emission (150 kHz to 30 MHz) and radiated emission (9 kHz to the 10th harmonic of the highest fundamental frequency or to 40 GHz, whichever is lower).

### 2.1 Carrier Frequency Channel

Frequency Band	Channel	Freq. (MHz)	Channel	Freq. (MHz)
2400-2483.5 MHz	1	2412	7	2442
	2	2417	8	2447
	3	2422	9	2452
	4	2427	10	2457
	5	2432	11	2462
	6	2437	-	-

### 2.2 Test Mode

Final test mode of radiated spurious emissions are considering the modulation and worse data rates as below table.

#### MIMO Antenna

Modulation	Data Rate
802.11b	1 Mbps

Test Cases	
<b>AC Conducted Emission</b>	Mode 1 :GSM1900 Idle + Bluetooth Link + WLAN (2.4GHz) Link + Camera + WPC Back Cover + LG Charging Pad + USB Cable (Charging from Adapter) Mode 2 :WCDMA Band V Idle + Bluetooth Link + WLAN (2.4GHz) Link + MPEG4 + WPC Back Cover + PMA Charging Pad + Adapter
<b>Remark:</b> The worst case of conducted emission is mode 2; only the test data of it was reported.	

## 2.3 Connection Diagram of Test System

<WLAN Tx Mode with LG Charging Pad>

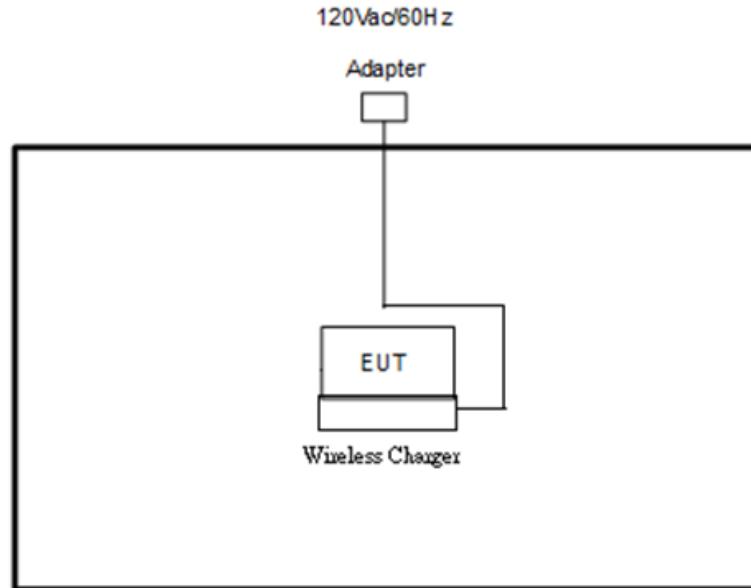

<WLAN Tx Mode with PMA Charging Pad>

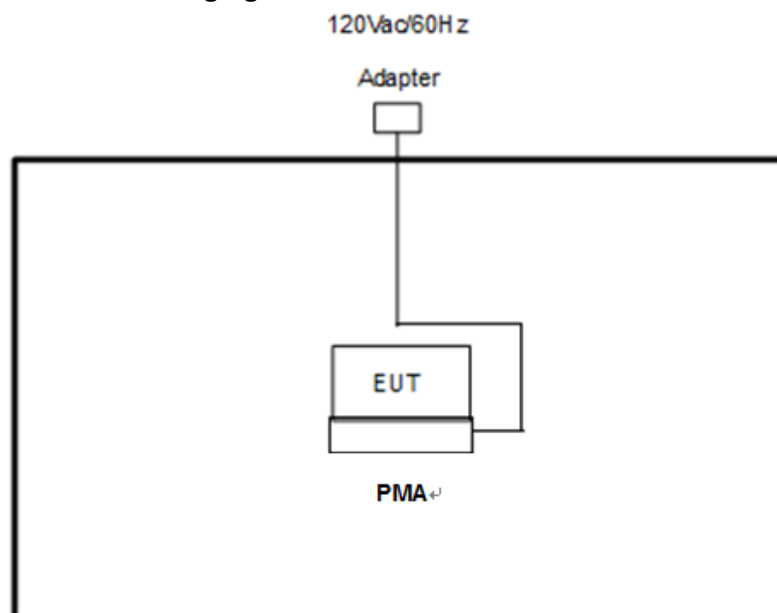

<AC Conducted Emission Mode with LG Charging Pad>

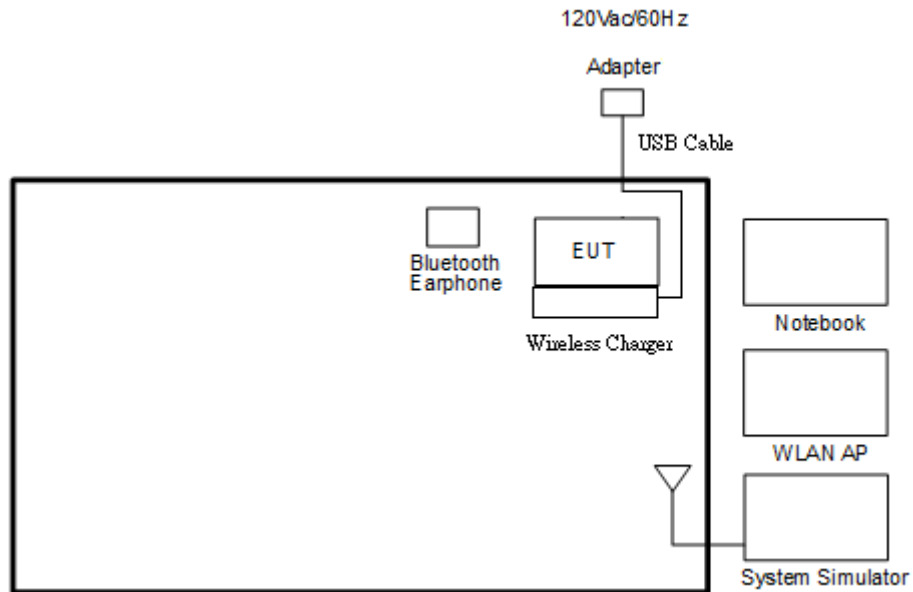

<AC Conducted Emission Mode with PMA Charging Pad>

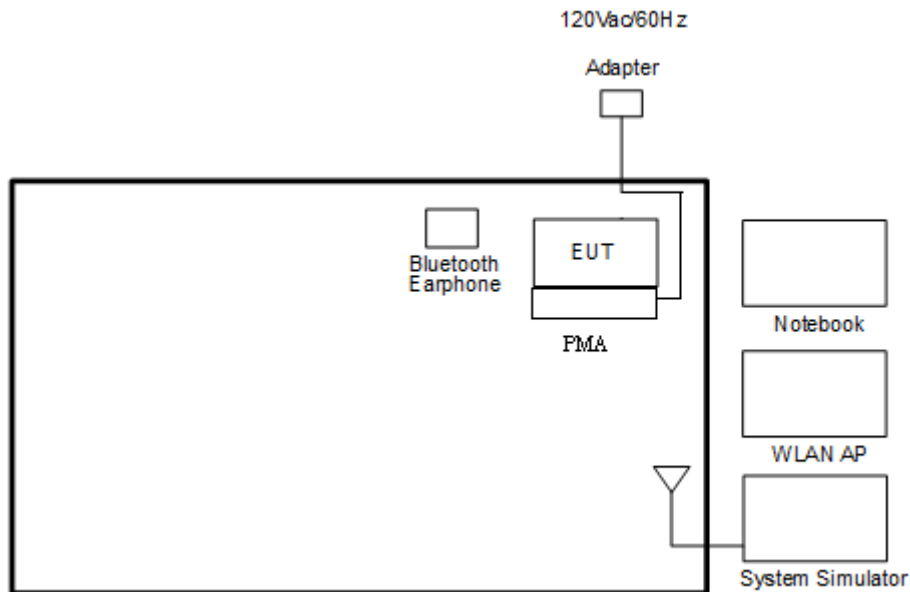



## 2.4 Support Unit used in test configuration and system

Item	Equipment	Trade Name	Model Name	FCC ID	Data Cable	Power Cord
1.	System Simulator	Anritsu	MT8820C	N/A	N/A	Unshielded, 1.8 m
2.	WLAN AP	D-Link	DIR-628	KA2DIR628A2	N/A	Unshielded, 1.8 m
3.	Notebook	DELL	Latitude E6320	FCC DoC/ Contains FCC ID: QDS-BRCM1054	N/A	AC I/P: Unshielded, 1.2 m DC O/P: Shielded, 1.8 m
4.	Bluetooth Earphone	Sony Ericsson	MW600	PY7DDA-2029	N/A	N/A
5.	SD Card	SanDisk	MicroSD HC	FCC DoC	N/A	N/A
6.	Wireless Charger	LG	WCD-100	FCC DoC	N/A	N/A
7.	PMA	DURACELL	M-018B-518A	FCC DoC	N/A	N/A

## 2.5 EUT Operation Test Setup

For WLAN function, programmed RF utility, "QRCT" installed in the notebook make the EUT provide functions like channel selection and power level for continuous transmitting and receiving signals.



### 3 Test Result

#### 3.1 Radiated Band Edges and Spurious Emission Measurement

##### 3.1.1 Limit of Radiated band edge and Spurious Emission Measurement

In any 100 kHz bandwidth outside the intentional radiator frequency band, all harmonics/spurious must be at least 20 dB below the highest emission level within the authorized band. If the output power of this device was measured by spectrum analyzer, the attenuation under this paragraph shall be 30 dB instead of 20 dB. In addition, radiated emissions which fall in the restricted bands must also comply with the FCC section 15.209 limits as below.

Frequency (MHz)	Field Strength (microvolts/meter)	Measurement Distance (meters)
0.009 – 0.490	2400/F(kHz)	300
0.490 – 1.705	24000/F(kHz)	30
1.705 – 30.0	30	30
30 – 88	100	3
88 – 216	150	3
216 - 960	200	3
Above 960	500	3

##### 3.1.2 Measuring Instruments

The measuring equipment is listed in the section 4 of this test report.



**3.1.3 Test Procedures**

1. The testing follows FCC KDB Publication No. 558074 D01 DTS Meas. Guidance v03r05.
2. The EUT was arranged to its worst case and then tune the antenna tower (from 1 m to 4 m) and turntable (from 0 degree to 360 degrees) to find the maximum reading. A pre-amp and a high pass filter are used for the test in order to get better signal level.
3. The EUT was placed on a turntable with 0.8 meter for frequency below 1GHz and 1.5 meter for frequency above 1GHz respectively above ground.
4. The EUT was set 3 meters from the interference receiving antenna, which was mounted on the top of a variable height antenna tower.
5. Corrected Reading: Antenna Factor + Cable Loss + Read Level - Preamp Factor = Level
6. For measurement below 1GHz, If the emission level of the EUT measured by the peak detector is 3 dB lower than the applicable limit, the peak emission level will be reported. Otherwise, the emission measurement will be repeated using the quasi-peak detector and reported.
7. Use the following spectrum analyzer settings:
  - (1) Span shall wide enough to fully capture the emission being measured;
  - (2) Set RBW=100 kHz for  $f < 1$  GHz; VBW  $\geq$  RBW; Sweep = auto; Detector function = peak; Trace = max hold;
  - (3) Set RBW = 1 MHz, VBW= 3MHz for  $f \geq 1$  GHz for peak measurement.  
For average measurement:
    - VBW = 10 Hz, when duty cycle is no less than 98 percent.
    - VBW  $\geq 1/T$ , when duty cycle is less than 98 percent where T is the minimum transmission duration over which the transmitter is on and is transmitting at its maximum power control level for the tested mode of operation.

### 3.1.4 Test Setup

For radiated emissions below 30MHz

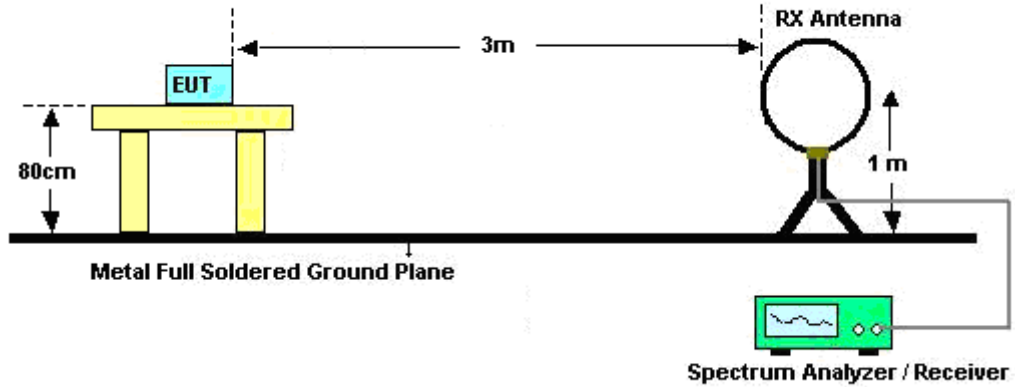

For radiated emissions from 30MHz to 1GHz

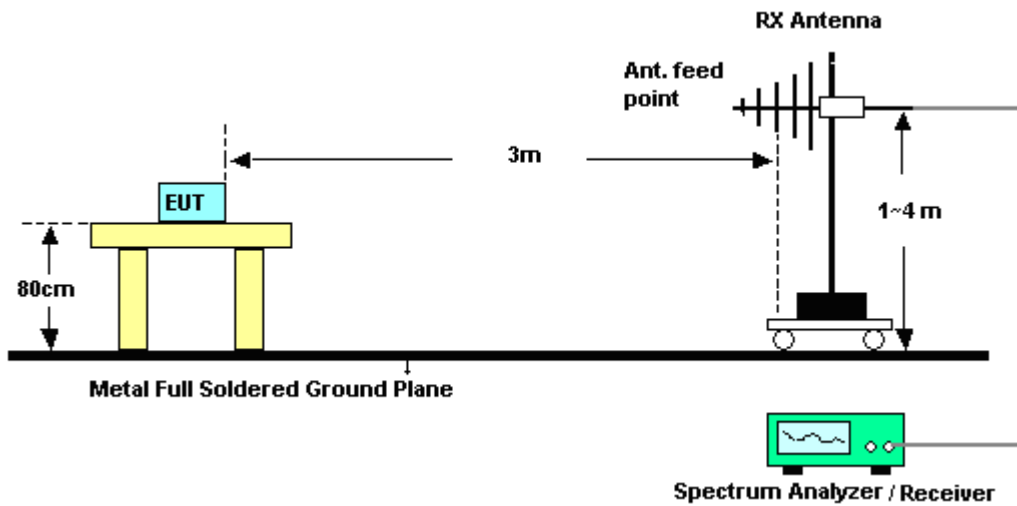

For radiated emissions above 1GHz

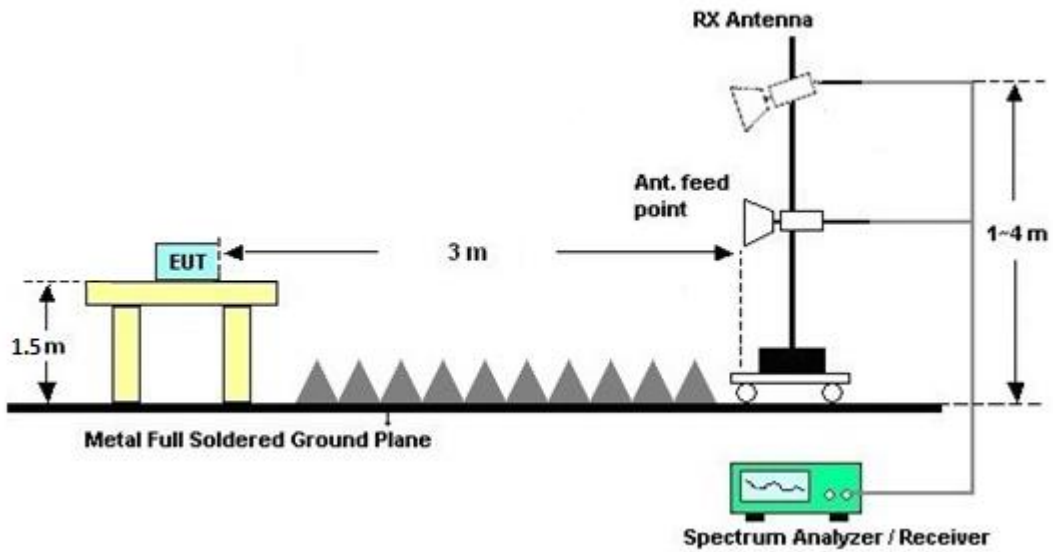

### 3.1.5 Test Results of Radiated Spurious Emissions (9kHz ~ 30MHz)

The low frequency, which started from 9 kHz to 30MHz, was pre-scanned and the result which was 20dB lower than the limit line per 15.31(o) was not reported.

### 3.1.6 Test Result of Radiated Spurious at Band Edges

Please refer to Appendix A and B.

### 3.1.7 Duty Cycle

Please refer to Appendix C.

### 3.1.8 Test Result of Radiated Spurious Emission (30MHz ~ 10<sup>th</sup> Harmonic)

Please refer to Appendix A and B.



### 3.2 AC Conducted Emission Measurement

#### 3.2.1 Limit of AC Conducted Emission

For equipment that is designed to be connected to the public utility (AC) power line, the radio frequency voltage that is conducted back onto the AC power line on any frequency or frequencies within the band 150 kHz to 30 MHz shall not exceed the limits in the following table.

Frequency of Emission (MHz)	Conducted Limit (dBµV)	
	Quasi-Peak	Average
0.15-0.5	66 to 56*	56 to 46*
0.5-5	56	46
5-30	60	50

\*Decreases with the logarithm of the frequency.

#### 3.2.2 Measuring Instruments

The measuring equipment is listed in the section 4 of this test report.

#### 3.2.3 Test Procedures

1. The EUT was placed 0.4 meter from the conducting wall of the shielding room, and it was kept at least 80 centimeters from any other grounded conducting surface.
2. Connect EUT to the power mains through a line impedance stabilization network (LISN).
3. All the support units are connecting to the other LISN.
4. The LISN provides 50 ohm coupling impedance for the measuring instrument.
5. The FCC states that a 50 ohm, 50 microhenry LISN should be used.
6. Both sides of AC line were checked for maximum conducted interference.
7. The frequency range from 150 kHz to 30 MHz was searched.
8. Set the test-receiver system to Peak Detect Function and specified bandwidth (IF bandwidth = 9kHz) with Maximum Hold Mode.

### 3.2.4 Test Setup

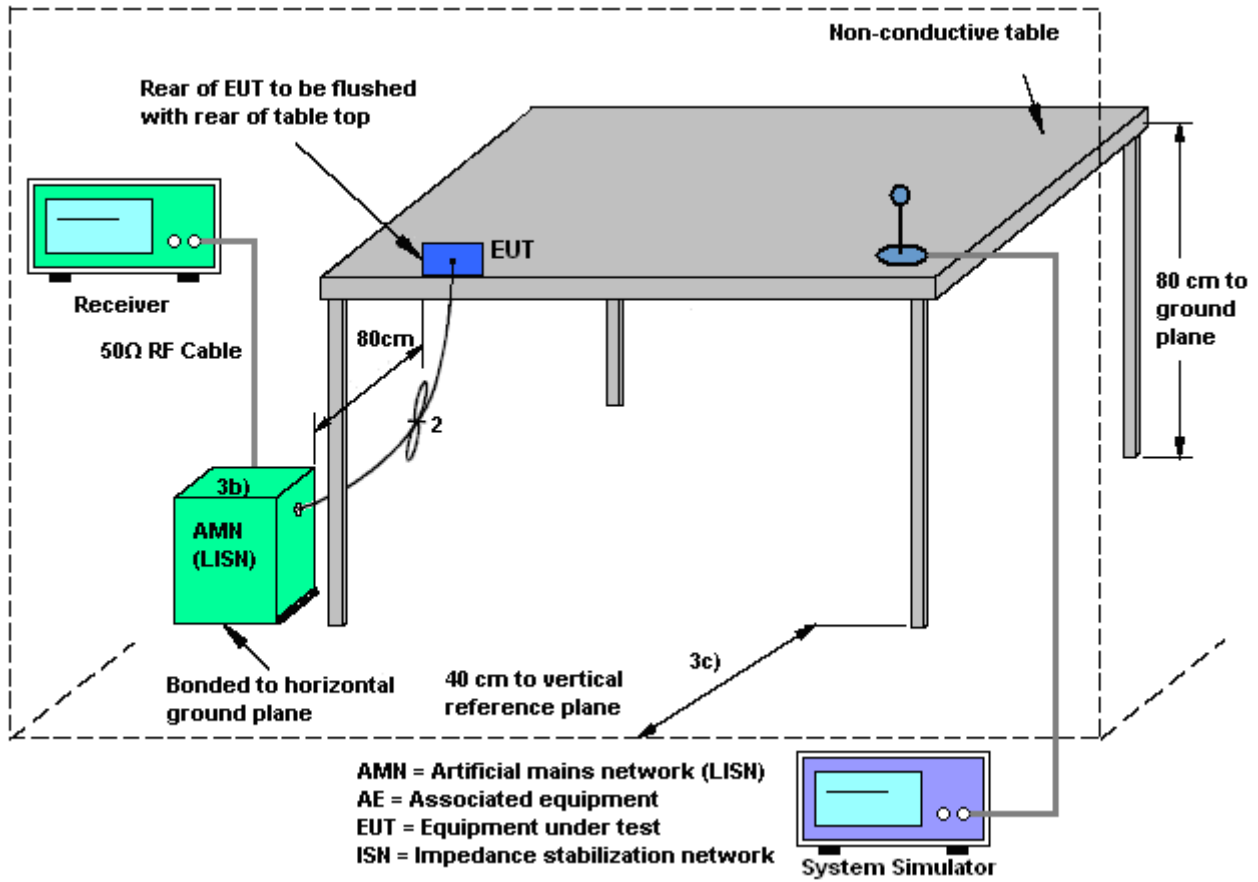



3.2.5 Test Result of AC Conducted Emission

Test Mode :	Mode 2	Temperature :	22~23°C
Test Engineer :	Kai-Chun Chu	Relative Humidity :	51~52%
Test Voltage :	120Vac / 60Hz	Phase :	Line
Function Type :	WCDMA Band V Idle + Bluetooth Link + WLAN (2.4GHz) Link + MPEG4 + WPC Back Cover + PMA Charging Pad + Adapter		

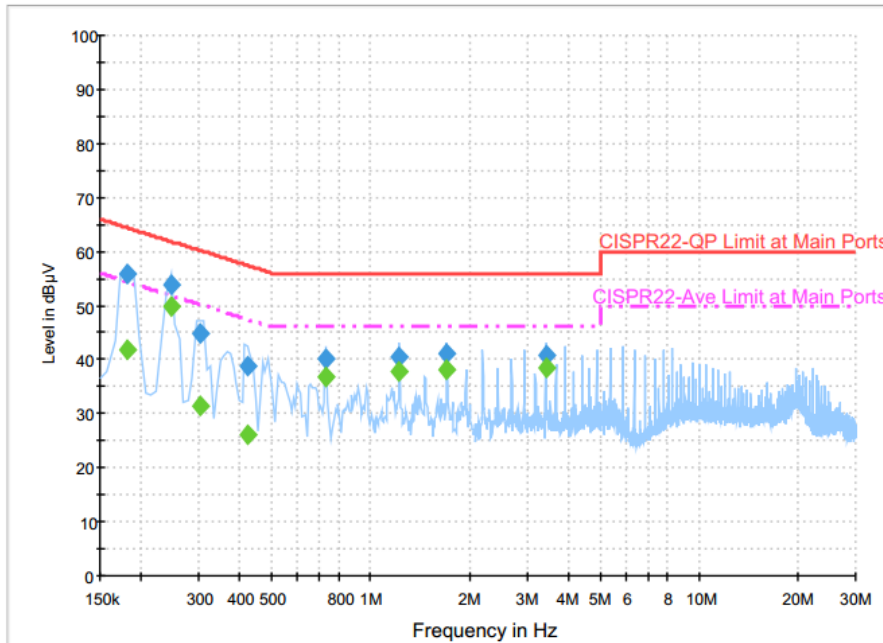

Final Result : Quasi-Peak

Frequency (MHz)	Quasi-Peak (dBµV)	Filter	Line	Corr. (dB)	Margin (dB)	Limit (dBµV)
0.182000	55.9	Off	L1	19.6	8.5	64.4
0.246000	53.9	Off	L1	19.6	8.0	61.9
0.302000	44.7	Off	L1	19.6	15.5	60.2
0.422000	38.9	Off	L1	19.6	18.5	57.4
0.734000	40.0	Off	L1	19.6	16.0	56.0
1.222000	40.5	Off	L1	19.7	15.5	56.0
1.710000	41.0	Off	L1	19.7	15.0	56.0
3.422000	41.0	Off	L1	19.7	15.0	56.0

Final Result : Average

Frequency (MHz)	Average (dBµV)	Filter	Line	Corr. (dB)	Margin (dB)	Limit (dBµV)
0.182000	41.8	Off	L1	19.6	12.6	54.4
0.246000	49.7	Off	L1	19.6	2.2	51.9
0.302000	31.5	Off	L1	19.6	18.7	50.2
0.422000	26.2	Off	L1	19.6	21.2	47.4
0.734000	36.9	Off	L1	19.6	9.1	46.0
1.222000	37.8	Off	L1	19.7	8.2	46.0
1.710000	38.2	Off	L1	19.7	7.8	46.0
3.422000	38.5	Off	L1	19.7	7.5	46.0



Test Mode :	Mode 2	Temperature :	22~23°C
Test Engineer :	Kai-Chun Chu	Relative Humidity :	51~52%
Test Voltage :	120Vac / 60Hz	Phase :	Neutral
Function Type :	WCDMA Band V Idle + Bluetooth Link + WLAN (2.4GHz) Link + MPEG4 + WPC Back Cover + PMA Charging Pad + Adapter		

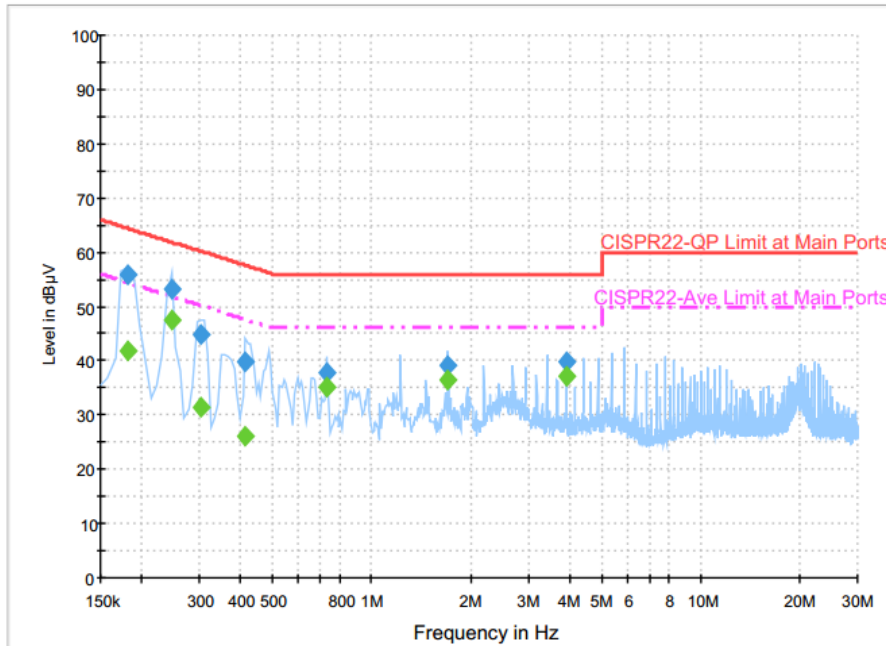

**Final Result : Quasi-Peak**

Frequency (MHz)	Quasi-Peak (dBµV)	Filter	Line	Corr. (dB)	Margin (dB)	Limit (dBµV)
0.182000	55.8	Off	N	19.6	8.6	64.4
0.246000	53.3	Off	N	19.6	8.6	61.9
0.302000	44.9	Off	N	19.6	15.3	60.2
0.414000	39.8	Off	N	19.6	17.8	57.6
0.734000	37.8	Off	N	19.6	18.2	56.0
1.710000	39.0	Off	N	19.7	17.0	56.0
3.910000	39.8	Off	N	19.8	16.2	56.0

**Final Result : Average**

Frequency (MHz)	Average (dBµV)	Filter	Line	Corr. (dB)	Margin (dB)	Limit (dBµV)
0.182000	41.9	Off	N	19.6	12.5	54.4
0.246000	47.4	Off	N	19.6	4.5	51.9
0.302000	31.3	Off	N	19.6	18.9	50.2
0.414000	26.0	Off	N	19.6	21.6	47.6
0.734000	35.0	Off	N	19.6	11.0	46.0
1.710000	36.6	Off	N	19.7	9.4	46.0
3.910000	37.3	Off	N	19.8	8.7	46.0



## 4 List of Measuring Equipment

Instrument	Manufacturer	Model No.	Serial No.	Characteristics	Calibration Date	Test Date	Due Date	Remark
AC Power Source	ChainTek	APC-1000W	N/A	N/A	N/A	Jul. 29, 2016 ~ Jul. 30, 2016	N/A	Conduction (CO05-HY)
EMI Test Receiver	Rohde & Schwarz	ESCI 7	100724	9kHz~7GHz	Aug. 26, 2015	Jul. 29, 2016 ~ Jul. 30, 2016	Aug. 25, 2016	Conduction (CO05-HY)
LISN	Rohde & Schwarz	ENV216	100080	9kHz~30MHz	Dec. 02, 2015	Jul. 29, 2016 ~ Jul. 30, 2016	Dec. 01, 2016	Conduction (CO05-HY)
Loop Antenna	Rohde & Schwarz	HFH2-Z2	100315	9 kHz~30 MHz	Sep. 02, 2015	Jul. 30, 2016 ~ Aug. 03, 2016	Sep. 01, 2016	Radiation (03CH11-HY)
Amplifier	SONOMA	310N	187312	9kHz~1GHz	Nov. 20, 2015	Jul. 30, 2016 ~ Aug. 03, 2016	Nov. 19, 2016	Radiation (03CH11-HY)
Bilog Antenna	TESEQ	CBL 6111D	35414	30MHz~1GHz	Nov. 17, 2015	Jul. 30, 2016 ~ Aug. 03, 2016	Nov. 16, 2016	Radiation (03CH11-HY)
Horn Antenna	SCHWARZBECK	BBHA 9120 D	9120D-1326	1GHz ~ 18GHz	Oct. 08, 2015	Jul. 30, 2016 ~ Aug. 03, 2016	Oct. 07, 2016	Radiation (03CH11-HY)
Preamplifier	Keysight	83017A	MY53270080	1GHz~26.5GHz	Nov. 19, 2015	Jul. 30, 2016 ~ Aug. 03, 2016	Nov. 18, 2016	Radiation (03CH11-HY)
Preamplifier	MITEQ	AMF-7D-0010 1800-30-10P	1902247	1GHz~18GHz	Jul. 22, 2016	Jul. 30, 2016 ~ Aug. 03, 2016	Jun. 21, 2017	Radiation (03CH11-HY)
Spectrum Analyzer	Keysight	N9010A	MY54200486	10Hz ~ 44GHZ	Sep. 24, 2015	Jul. 30, 2016 ~ Aug. 03, 2016	Sep. 23, 2016	Radiation (03CH11-HY)
Antenna Mast	EMEC	AM-BS-4500-B	N/A	1~4m	N/A	Jul. 30, 2016 ~ Aug. 03, 2016	N/A	Radiation (03CH11-HY)
Turn Table	EMEC	TT 2000	N/A	0~360 Degree	N/A	Jul. 30, 2016 ~ Aug. 03, 2016	N/A	Radiation (03CH11-HY)
SHF-EHF Horn Antenna	SCHWARZBECK	BBHA 9170	BBHA9170584	18GHz- 40GHz	Nov. 02, 2015	Jul. 30, 2016 ~ Aug. 03, 2016	Nov. 01, 2016	Radiation (03CH11-HY)
Preamplifier	MITEQ	TTA0204	1872107	2GHz~40GHz	Feb. 15, 2016	Jul. 30, 2016 ~ Aug. 03, 2016	Feb. 14, 2017	Radiation (03CH11-HY)



## 5 Uncertainty of Evaluation

### Uncertainty of Conducted Emission Measurement (150kHz ~ 30MHz)

Measuring Uncertainty for a Level of Confidence of 95% ( $U = 2Uc(y)$ )	2.26
---	------

### Uncertainty of Radiated Emission Measurement (30 MHz ~ 1000 MHz)

Measuring Uncertainty for a Level of Confidence of 95% ( $U = 2Uc(y)$ )	5.20
---	------



## Appendix A. Radiated Spurious Emission

Test Engineer :	J.C. Liang	Temperature :	20~23°C
		Relative Humidity :	50~54%

2.4GHz 2400~2483.5MHz

WIFI 802.11b (Band Edge @ 3m)

<WPC Back Cover + LG Charging Pad>

WIFI Ant. 1+2	Note	Frequency ( MHz )	Level ( dBμV/m )	Over Limit ( dB )	Limit Line ( dBμV/m )	Read Level ( dBμV )	Antenna Factor ( dB/m )	Cable Loss ( dB )	Preamp Factor ( dB )	Ant Pos ( cm )	Table Pos ( deg )	Peak Avg. ( P/A )	Pol. ( H/V )
802.11b CH 11 2462MHz	*	2462	105.48	-	-	105.47	27.2	6.77	33.96	254	59	P	H
		2462	94.9	-	-	94.89	27.2	6.77	33.96	254	59	A	H
		2483.72	52.13	-21.87	74	52.06	27.25	6.77	33.95	254	59	P	H
		2483.52	44.13	-9.87	54	44.06	27.25	6.77	33.95	254	59	A	H
													H
													H
	*	2462	103.87	-	-	103.86	27.2	6.77	33.96	151	118	P	V
		2462	100.78	-	-	100.77	27.2	6.77	33.96	151	118	A	V
		2487.84	52.43	-21.57	74	52.31	27.3	6.77	33.95	151	118	P	V
		2483.52	43.43	-10.57	54	43.36	27.25	6.77	33.95	151	118	A	V
Remark	1. No other spurious found. 2. All results are PASS against Peak and Average limit line.												



2.4GHz 2400~2483.5MHz

WIFI 802.11b (Band Edge @ 3m)

<WPC Back Cover + PMA Charging Pad>

WIFI Ant. 1+2	Note	Frequency ( MHz )	Level ( dBμV/m )	Over Limit ( dB )	Limit Line ( dBμV/m )	Read Level ( dBμV )	Antenna Factor ( dB/m )	Cable Loss ( dB )	Preamp Factor ( dB )	Ant Pos ( cm )	Table Pos ( deg )	Peak Avg. (P/A)	Pol. (H/V)
802.11b CH 11 2462MHz	*	2462	105.3	-	-	105.29	27.2	6.77	33.96	400	86	P	H
		2462	102.16	-	-	102.15	27.2	6.77	33.96	400	86	A	H
		2486.16	52.56	-21.44	74	52.49	27.25	6.77	33.95	400	86	P	H
		2483.52	44.31	-9.69	54	44.24	27.25	6.77	33.95	400	86	A	H
													H
													H
	*	2462	102.99	-	-	102.98	27.2	6.77	33.96	400	248	P	V
		2462	99.62	-	-	99.61	27.2	6.77	33.96	400	248	A	V
		2498.72	52.52	-21.48	74	52.39	27.3	6.77	33.94	400	248	P	V
		2483.52	44.16	-9.84	54	44.09	27.25	6.77	33.95	400	248	A	V
													V
													V
Remark	1. No other spurious found. 2. All results are PASS against Peak and Average limit line.												



2.4GHz 2400~2483.5MHz

WIFI 802.11b (Harmonic @ 3m)

<WPC Back Cover + LG Charging Pad>

WIFI Ant. 1+2	Note	Frequency ( MHz )	Level ( dBμV/m )	Over Limit ( dB )	Limit Line ( dBμV/m )	Read Level ( dBμV )	Antenna Factor ( dB/m )	Cable Loss ( dB )	Preamp Factor ( dB )	Ant Pos ( cm )	Table Pos ( deg )	Peak Avg. ( P/A )	Pol. ( H/V )
802.11b CH 11 2462MHz		4924	33.9	-40.1	74	43.26	31.29	10.39	51.04	100	0	P	H
		7386	38.42	-35.58	74	40.17	36.27	12.49	50.51	100	0	P	H
													H
													H
		4924	34.6	-39.4	74	43.96	31.29	10.39	51.04	100	0	P	V
		7386	38.06	-35.94	74	39.81	36.27	12.49	50.51	100	0	P	V
													V
													V
Remark	1. No other spurious found. 2. All results are PASS against Peak and Average limit line.												

2.4GHz 2400~2483.5MHz

WIFI 802.11b (Harmonic @ 3m)

<WPC Back Cover + PMA Charging Pad>

WIFI Ant. 1+2	Note	Frequency ( MHz )	Level ( dBμV/m )	Over Limit ( dB )	Limit Line ( dBμV/m )	Read Level ( dBμV )	Antenna Factor ( dB/m )	Cable Loss ( dB )	Preamp Factor ( dB )	Ant Pos ( cm )	Table Pos ( deg )	Peak Avg. ( P/A )	Pol. ( H/V )
802.11b CH 11 2462MHz		4924	34.05	-39.95	74	43.41	31.29	10.39	51.04	100	0	P	H
		7386	38.03	-35.97	74	39.78	36.27	12.49	50.51	100	0	P	H
													H
													H
		4924	34.85	-39.15	74	44.21	31.29	10.39	51.04	100	0	P	V
		7386	38.29	-35.71	74	40.04	36.27	12.49	50.51	100	0	P	V
													V
													V
Remark	1. No other spurious found. 2. All results are PASS against Peak and Average limit line.												







**Note symbol**

*	<b>Fundamental Frequency</b> which can be ignored. However, the level of any unwanted emissions shall not exceed the level of the fundamental frequency.
!	Test result is <b>over limit</b> line.
P/A	<b>Peak</b> or <b>Average</b>
H/V	<b>Horizontal</b> or <b>Vertical</b>



A calculation example for radiated spurious emission is shown as below:

WIFI Ant. 1+2	Note	Frequency ( MHz )	Level ( dBμV/m )	Over Limit ( dB )	Limit Line ( dBμV/m )	Read Level ( dBμV )	Antenna Factor ( dB/m )	Cable Loss ( dB )	Preamp Factor ( dB )	Ant Pos ( cm )	Table Pos ( deg )	Peak Avg. ( P/A )	Pol. ( H/V )
802.11b CH 01 2412MHz		2390	55.45	-18.55	74	54.51	32.22	4.58	35.86	103	308	P	H
		2390	43.54	-10.46	54	42.6	32.22	4.58	35.86	103	308	A	H

- Level(dBμV/m) =  
Antenna Factor(dB/m) + Cable Loss(dB) + Read Level(dBμV) - Preamp Factor(dB)
- Over Limit(dB) = Level(dBμV/m) – Limit Line(dBμV/m)

**For Peak Limit @ 2390MHz:**

- Level(dBμV/m)  
= Antenna Factor(dB/m) + Cable Loss(dB) + Read Level(dBμV) - Preamp Factor(dB)  
= 32.22(dB/m) + 4.58(dB) + 54.51(dBμV) – 35.86 (dB)  
= 55.45 (dBμV/m)
- Over Limit(dB)  
= Level(dBμV/m) – Limit Line(dBμV/m)  
= 55.45(dBμV/m) – 74(dBμV/m)  
= -18.55(dB)

**For Average Limit @ 2390MHz:**

- Level(dBμV/m)  
= Antenna Factor(dB/m) + Cable Loss(dB) + Read Level(dBμV) - Preamp Factor(dB)  
= 32.22(dB/m) + 4.58(dB) + 42.6(dBμV) – 35.86 (dB)  
= 43.54 (dBμV/m)
- Over Limit(dB)  
= Level(dBμV/m) – Limit Line(dBμV/m)  
= 43.54(dBμV/m) – 54(dBμV/m)  
= -10.46(dB)

**Both peak and average measured complies with the limit line, so test result is “PASS”.**



## Appendix B. Radiated Spurious Emission Plots

Test Engineer :	J.C. Liang	Temperature :	20~23°C
		Relative Humidity :	50~54%

### Note symbol

-L	Low channel location
-R	High channel location



**2.4GHz 2400~2483.5MHz**  
**WIFI 802.11b (Band Edge @ 3m)**  
**<WPC Back Cover + LG Charging Pad>**

WIFI	2.4GHz 2400~2483.5MHz Band Edge @ 3m	
ANT	802.11b CH11 2462MHz	
1+2	Horizontal	Fundamental
Peak	<p>Date: 2016-08-03</p> <p>Site : 03CH11-HY            Condition : PEAK_BE_74 3m HORN 9120D-HF HORIZONTAL            Detector : Peak            Project : 632103-09            Mode : 5            : WPC cover + LG</p>	<p>Date: 2016-08-03</p> <p>Site : 03CH11-HY            Condition : PEAK_74 3m HORN 9120D-HF HORIZONTAL            Detector : Peak            Project : 632103-09            Mode : 5            : WPC cover + LG</p>
Avg.	<p>Date: 2016-08-03</p> <p>Site : 03CH11-HY            Condition : AVG_BE_54 3m HORN 9120D-HF HORIZONTAL            Detector : Peak            Project : 632103-09            Mode : 5            : WPC cover + LG</p>	<p>Date: 2016-08-03</p> <p>Site : 03CH11-HY            Condition : AVG_54 3m HORN 9120D-HF HORIZONTAL            Detector : Peak            Project : 632103-09            Mode : 5            : WPC cover + LG</p>

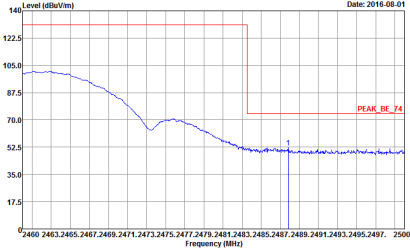
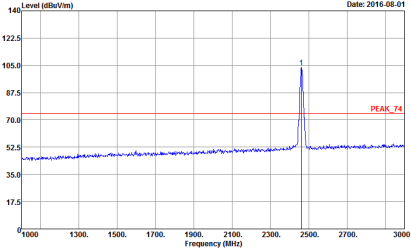
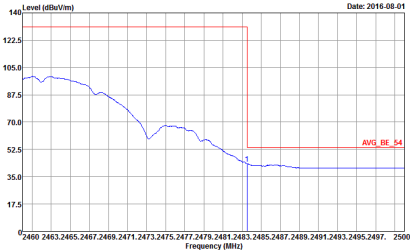
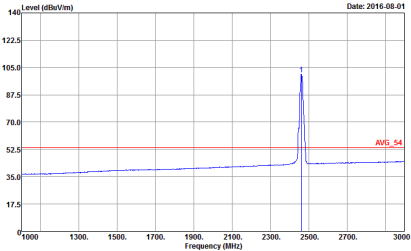

WIFI	2.4GHz 2400~2483.5MHz Fundamental @ 3m	
ANT	802.11b CH11 2462MHz	
1+2	Vertical	Fundamental
Peak	 <p>Site : 03CH11-HY            Condition : PEAK_BE_74 3m HORN 9120D-HF VERTICAL            Detector : Peak            Project : 632103-09            Mode : 5                      : WPC cover + LG</p>	 <p>Site : 03CH11-HY            Condition : PEAK_74 3m HORN 9120D-HF VERTICAL            Detector : Peak            Project : 632103-09            Mode : 5                      : WPC cover + LG</p>
Avg.	 <p>Site : 03CH11-HY            Condition : AVG_BE_54 3m HORN 9120D-HF VERTICAL            Detector : Peak            Project : 632103-09            Mode : 5                      : WPC cover + LG</p>	 <p>Site : 03CH11-HY            Condition : AVG_54 3m HORN 9120D-HF VERTICAL            Detector : Peak            Project : 632103-09            Mode : 5                      : WPC cover + LG</p>

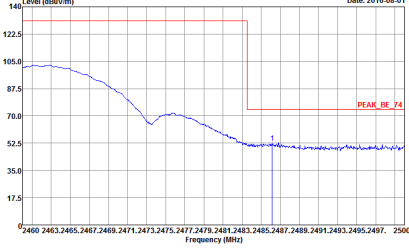
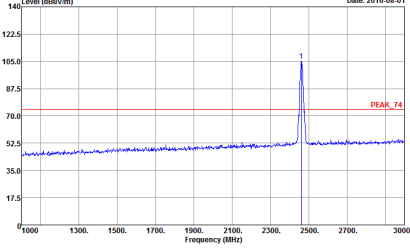
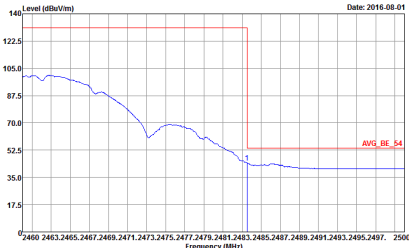
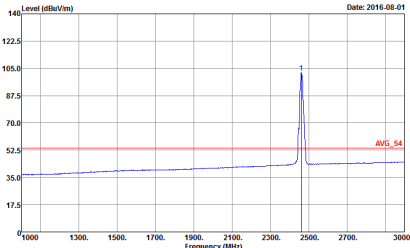

**2.4GHz 2400~2483.5MHz**  
**WIFI 802.11b (Band Edge @ 3m)**  
**<WPC Back Cover + PMA Charging Pad>**

WIFI	2.4GHz 2400~2483.5MHz Band Edge @ 3m	
ANT	802.11b CH11 2462MHz	
1+2	Horizontal	Fundamental
Peak	 <p>           Date: 2016-08-01            Level (dBuV/m)            140 122.5 105.0 87.5 70.0 52.5 35.0 17.5 0         </p> <p>           Frequency (MHz)            2460 2463.2465.2467.2469.2471.2473.2475.2477.2479.2481.2483.2485.2487.2489.2491.2493.2495.2497. 2500         </p> <p>           Site : 03CH11-HY            Condition : PEAK_BE_74 3m HORN 9120D-HF HORIZONTAL            Detector : RBW:1000.000KHz VBW:3000.000KHz SWT:Auto            Detector : Peak            Project : 632103-09            Mode : 6            : WPC cover + PMA         </p>	 <p>           Date: 2016-08-01            Level (dBuV/m)            140 122.5 105.0 87.5 70.0 52.5 35.0 17.5 0         </p> <p>           Frequency (MHz)            1000 1300 1500 1700 1900 2100 2300 2500 2700 3000         </p> <p>           Site : 03CH11-HY            Condition : PEAK_74 3m HORN 9120D-HF HORIZONTAL            Detector : RBW:1000.000KHz VBW:3000.000KHz SWT:Auto            Detector : Peak            Project : 632103-09            Mode : 6            : WPC cover + PMA         </p>
Avg.	 <p>           Date: 2016-08-01            Level (dBuV/m)            140 122.5 105.0 87.5 70.0 52.5 35.0 17.5 0         </p> <p>           Frequency (MHz)            2460 2463.2465.2467.2469.2471.2473.2475.2477.2479.2481.2483.2485.2487.2489.2491.2493.2495.2497. 2500         </p> <p>           Site : 03CH11-HY            Condition : AVG_BE_54 3m HORN 9120D-HF HORIZONTAL            Detector : RBW:1000.000KHz VBW:0.010KHz SWT:Auto            Detector : Peak            Project : 632103-09            Mode : 6            : WPC cover + PMA         </p>	 <p>           Date: 2016-08-01            Level (dBuV/m)            140 122.5 105.0 87.5 70.0 52.5 35.0 17.5 0         </p> <p>           Frequency (MHz)            1000 1300 1500 1700 1900 2100 2300 2500 2700 3000         </p> <p>           Site : 03CH11-HY            Condition : AVG_54 3m HORN 9120D-HF HORIZONTAL            Detector : RBW:1000.000KHz VBW:0.010KHz SWT:Auto            Detector : Peak            Project : 632103-09            Mode : 6            : WPC cover + PMA         </p>

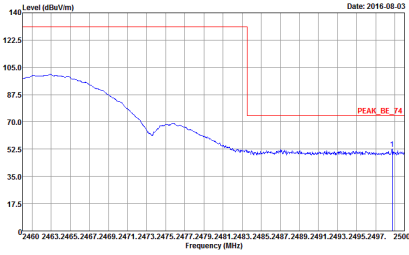
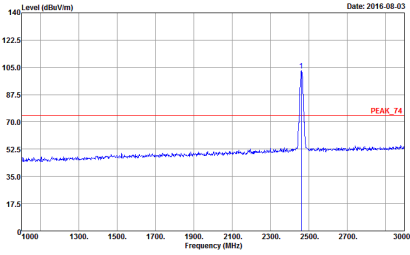
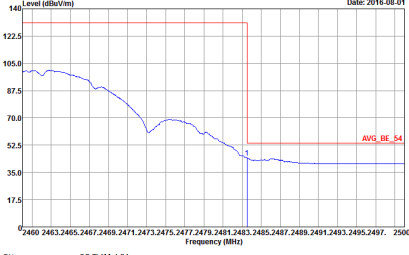
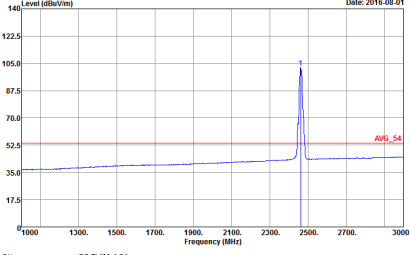

WIFI	2.4GHz 2400~2483.5MHz Fundamental @ 3m	
ANT	802.11b CH11 2462MHz	
1+2	Vertical	Fundamental
<p><b>Peak</b></p>	 <p>Site : 03CH11-HY            Condition : PEAK_BE_74 3m HORN 9120D-HF VERTICAL            RBW:1000.000KHz VBW:3000.000KHz SWT:Auto            Detector : Peak            Project : 632103-09            Mode : 6            : WPC cover + PMA</p>	 <p>Site : 03CH11-HY            Condition : PEAK_74 3m HORN 9120D-HF VERTICAL            RBW:1000.000KHz VBW:3000.000KHz SWT:Auto            Detector : Peak            Project : 632103-09            Mode : 6            : WPC cover + PMA</p>
<p><b>Avg.</b></p>	 <p>Site : 03CH11-HY            Condition : AVG_BE_54 3m HORN 9120D-HF HORIZONTAL            RBW:1000.000KHz VBW:0.010KHz SWT:Auto            Detector : Peak            Project : 632103-09            Mode : 6            : WPC cover + PMA</p>	 <p>Site : 03CH11-HY            Condition : AVG_54 3m HORN 9120D-HF HORIZONTAL            RBW:1000.000KHz VBW:0.010KHz SWT:Auto            Detector : Peak            Project : 632103-09            Mode : 6            : WPC cover + PMA</p>



**2.4GHz 2400~2483.5MHz**  
**WIFI 802.11b (Harmonic @ 3m)**  
**<WPC Back Cover + LG Charging Pad>**

<b>WIFI</b>	<b>2.4GHz 2400~2483.5MHz Harmonic @ 3m</b>	
<b>ANT</b>	<b>802.11b CH11 2462MHz</b>	
<b>1+2</b>	<b>Horizontal</b>	<b>Vertical</b>
<b>Peak</b>	<p>Site : 03CH11-HY  Condition : PEAK_74 3m 9170 SHF HORM_150809 HORIZONTAL  Detector : Peak  Project : 632103-09  Mode : 5  : WPC cover + LG</p>	<p>Site : 03CH11-HY  Condition : PEAK_74 3m 9170 SHF HORM_150809 VERTICAL  Detector : Peak  Project : 632103-09  Mode : 5  : WPC cover + LG</p>
<b>Avg.</b>		



**2.4GHz 2400~2483.5MHz**  
**WIFI 802.11b (Harmonic @ 3m)**  
**<WPC Back Cover + PMA Charging Pad>**

<b>WIFI</b>	<b>2.4GHz 2400~2483.5MHz Harmonic @ 3m</b>	
<b>ANT</b>	<b>802.11b CH11 2462MHz</b>	
<b>1+2</b>	<b>Horizontal</b>	<b>Vertical</b>
<b>Peak</b>	<p>Site : 03CH11-HY          Condition : PEAK_74 3m 9170 SHF HORM_150809 HORIZONTAL          Detector : Peak          Project : 632103-09          Mode : 6          : WPC cover + PMA</p>	<p>Site : 03CH11-HY          Condition : PEAK_74 3m 9170 SHF HORM_150809 VERTICAL          Detector : Peak          Project : 632103-09          Mode : 6          : WPC cover + PMA</p>
<b>Avg.</b>		



Emission below 1GHz
2.4GHz WIFI 802.11b (LF)
<WPC Back Cover + LG Charging Pad>

Table with 2 columns: Horizontal and Vertical. Each column contains a spectral plot of Level (dBuV/m) vs Frequency (MHz) from 30 to 1000 MHz. The plots show a blue signal line with several peaks and a red step function line. Metadata for both plots includes Site: 03CH11-HY, Condition: QP 3m BE-LOG 6111D-LF\_ETC, Detector: Peak, Project: 632103-09, Mode: 5, and WPC cover + LG.



Emission below 1GHz
2.4GHz WIFI 802.11b (LF)
<WPC Back Cover + PMA Charging Pad>

Table with 2 columns: Horizontal and Vertical. Each column contains a graph of Level (dBuV/m) vs Frequency (MHz) and associated test parameters like Site, Condition, Detector, Project, and Mode.



### Appendix C. Duty Cycle Plots

Antenna	Band	Duty Cycle(%)	T(us)	1/T(kHz)	VBW Setting
1+2	2.4GHz 802.11b for Ant 1	99.04	-	-	10Hz
1+2	2.4GHz 802.11b for Ant 2	99.05	-	-	10Hz

#### MIMO <Ant. 1+2(1)>

#### 802.11b

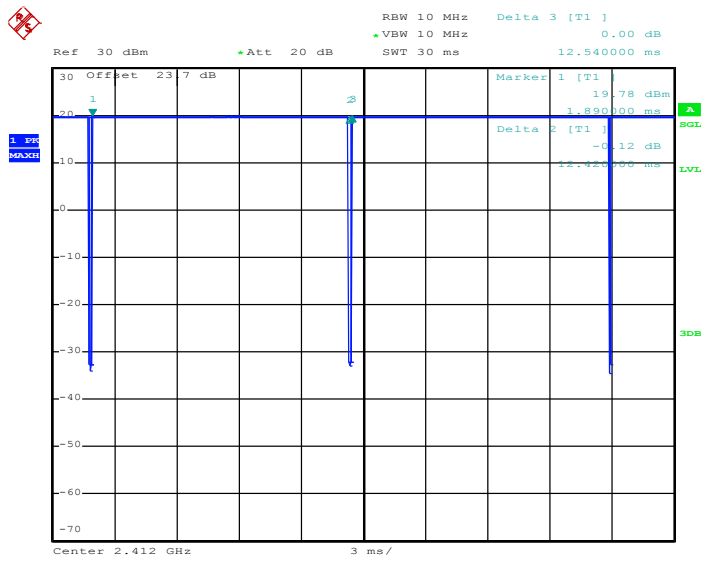

Date: 8.APR.2016 16:15:33



MIMO <Ant. 1+2(2)>

802.11b

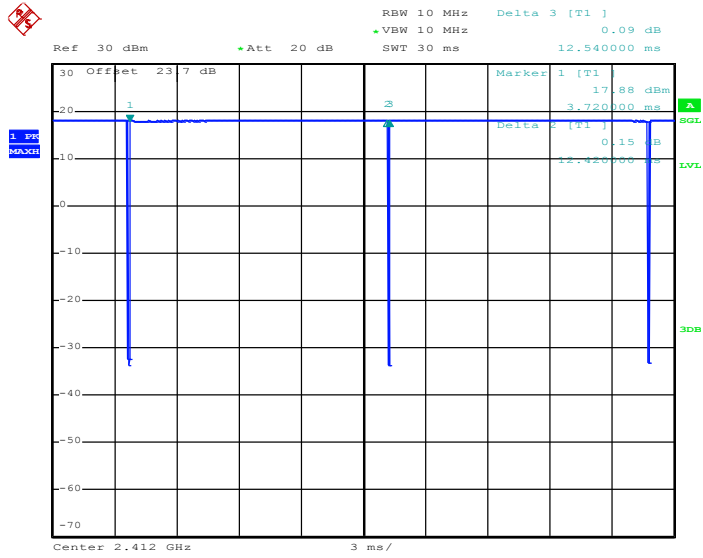

Date: 8.APR.2016 16:14:29



## **Appendix D. Original Report**

Please refer to Sporton report number FR632103C as below.



# FCC RF Test Report

APPLICANT : Motorola Mobility, LLC  
EQUIPMENT : Mobile Cellular Phone  
BRAND NAME : Motorola  
MODEL NAME : 6576  
FCC ID : IHDT56VB4  
STANDARD : FCC Part 15 Subpart C §15.247  
CLASSIFICATION : (DTS) Digital Transmission System

This is a variant report which is only valid together with the original test report. The product was received on Mar. 21, 2016. We, SPORTON INTERNATIONAL INC., would like to declare that the tested sample has been evaluated in accordance with the test procedures and has been in compliance with the applicable technical standards.

The test results in this report apply exclusively to the tested model / sample. Without written approval of SPORTON INTERNATIONAL INC., the test report shall not be reproduced except in full.

Reviewed by: Joseph Lin / Supervisor

Approved by: Jones Tsai / Manager



## SPORTON INTERNATIONAL INC.

No. 52, Hwa Ya 1<sup>st</sup> Rd., Hwa Ya Technology Park, Kwei-Shan District, Tao Yuan City, Taiwan, R.O.C.

SPORTON INTERNATIONAL INC.

TEL : 886-3-327-3456

FAX : 886-3-328-4978

FCC ID : IHDT56VB4

Page Number : 1 of 5

Report Issued Date : Jun. 16, 2016

Report Version : Rev. 01

Report Template No.: BU5-FR15CWLAC Version 1.3



# TABLE OF CONTENTS

**REVISION HISTORY** ..... 3

**1 GENERAL DESCRIPTION** ..... 4

    1.1 Applicant ..... 4

    1.2 Manufacturer ..... 4

    1.3 Product Feature of Equipment Under Test ..... 4

    1.4 Re-use of Measured Data ..... 5

    1.5 Modification of EUT ..... 5

**APPENDIX A. ORIGINAL REPORT**





# 1 General Description

## 1.1 Applicant

Motorola Mobility, LLC

222 W Merchandise Mart Plaza, Suite 1800, Chicago, IL 60654, United States

## 1.2 Manufacturer

Motorola Mobility, LLC

222 W Merchandise Mart Plaza, Suite 1800, Chicago, IL 60654, United States

## 1.3 Product Feature of Equipment Under Test

Product Feature	
Equipment	Mobile Cellular Phone
Brand Name	Motorola
Model Name	6576
FCC ID	IHDT56VB4
EUT supports Radios application	GSM/EGPRS/WCDMA/HSPA/LTE/NFC 2.4GHz WLAN 11b/g/n HT20 WLAN 11ac VHT20 5GHz WLAN 11a/n HT20/HT40 WLAN 11ac VHT20/VHT40/VHT80 Bluetooth v3.0 EDR Bluetooth v4.2 LE
HW Version	DVT2
EUT Stage	Identical Prototype

**Remark:** The above EUT's information was declared by manufacturer. Please refer to the specifications or user's manual for more detailed description.



## 1.4 Re-use of Measured Data

### 1.4.1 Introduction Section

This application re-uses data collected on a similar device. The subject device of this application (Model 6576, FCC ID IHDT56VB4) is electrically identical to the reference device (Model 4237, FCC ID IHDT56VB1) for the portions of the circuitry corresponding to the data being re-used, as treated by KDB Publication 178919 D01.

### 1.4.2 Difference Section

For details concerning the similarity with respect to component placement, mechanical/electrical design etc., please refer to the Operational Description.

The re-used RF data includes the following bands provided in Appendix A (Sporton RF Report No. FR631828C for the reference device Model 4237, FCC ID IHDT56VB1):

- 2.4GHz WLAN

### 1.4.3 Spot Check Verification Data Section

In order to confirm hardware similarity of the subject device with the reference device, spot check measurements were performed on the subject device for radiated spurious emission, the test result were consistent with FCC ID IHDT56VB1.

Assertions concerning the similarity of these devices are based on representations by the applicant. The applicant accepts full responsibility for the validity of the similarity claim, and for the determination that verification test data are sufficient to support it.

### 1.4.4 Reference detail Section:

Equipment Class	Reference FCC ID	Folder Test/RF Exposure	Report Title/Section
DTS	IHDT56VB1	Part15C (FR631828C)	All sections applicable

## 1.5 Modification of EUT

No modifications are made to the EUT during all test items.



## **Appendix A. Original Report**

Please refer to Sporton report number FR631828C.