



FCC RF Test Report

APPLICANT : Motorola Mobility, LLC
EQUIPMENT : Mobile Cellular Phone
BRAND NAME : Motorola
MODEL NAME : 4237
FCC ID : IHDT56VB1
STANDARD : FCC Part 15 Subpart E §15.407
CLASSIFICATION : (NII) Unlicensed National Information Infrastructure

This is a variant report which is only valid together with the original test report. The product was received on May 17, 2016 and testing was completed on May 22, 2016. We, SPORTON INTERNATIONAL INC., would like to declare that the tested sample has been evaluated in accordance with the test procedures and has been in compliance with the applicable technical standards.

The test results in this report apply exclusively to the tested model / sample. Without written approval of SPORTON INTERNATIONAL INC., the test report shall not be reproduced except in full.

Reviewed by: Joseph Lin / Supervisor

Approved by: Jones Tsai / Manager



Testing Laboratory
1190

SPORTON INTERNATIONAL INC.

No. 52, Hwa Ya 1st Rd., Hwa Ya Technology Park, Kwei-Shan District, Tao Yuan City, Taiwan, R.O.C.



TABLE OF CONTENTS

REVISION HISTORY..... 3

SUMMARY OF TEST RESULT 4

1 GENERAL DESCRIPTION 5

 1.1 Applicant 5

 1.2 Manufacturer..... 5

 1.3 Product Feature of Equipment Under Test..... 5

 1.4 Product Specification of Equipment Under Test..... 6

 1.5 Modification of EUT 6

 1.6 Testing Location 7

 1.7 Applicable Standards..... 7

2 TEST CONFIGURATION OF EQUIPMENT UNDER TEST 8

 2.1 Carrier Frequency and Channel 9

 2.2 Test Mode..... 10

 2.3 Connection Diagram of Test System..... 11

 2.4 Support Unit used in test configuration and system 13

 2.5 EUT Operation Test Setup 13

3 TEST RESULT..... 14

 3.1 Unwanted Emissions Measurement..... 14

 3.2 AC Conducted Emission Measurement..... 18

4 LIST OF MEASURING EQUIPMENT 22

5 UNCERTAINTY OF EVALUATION..... 23

APPENDIX A. RADIATED SPURIOUS EMISSION

APPENDIX B. RADIATED SPURIOUS EMISSION PLOTS

APPENDIX C. DUTY CYCLE PLOTS

APPENDIX D. ORIGINAL REPORT



SUMMARY OF TEST RESULT

Report Section	FCC Rule	Description	Limit	Result	Remark
3.1	15.407(b)	Unwanted Emissions	$\leq -17, -27$ dBm (depend on band) &15.209(a)	Pass	Under limit 1.08 dB at 5468.400 MHz
3.2	15.207	AC Conducted Emission	15.207(a)	Pass	Under limit 7.10 dB at 0.798 MHz



1 General Description

1.1 Applicant

Motorola Mobility, LLC

222 W Merchandise Mart Plaza, Suite 1800, Chicago, IL 60654, United States

1.2 Manufacturer

Motorola Mobility, LLC

222 W Merchandise Mart Plaza, Suite 1800, Chicago, IL 60654, United States

1.3 Product Feature of Equipment Under Test

Product Feature	
Equipment	Mobile Cellular Phone
Brand Name	Motorola
Model Name	4237
FCC ID	IHDT56VB1
IMEI Code	354107070048603 (for Radiation) 354107070049056 (for Conduction)
EUT supports Radios application	CDMA/EV-DO/GSM/EGPRS/WCDMA/HSPA/LTE/NFC WLAN 11b/g/n HT20/VHT20 WLAN 11a/n HT20/HT40 WLAN 11ac VHT20/VHT40/VHT80 Bluetooth v3.0 EDR Bluetooth v4.2 LE
HW Version	DVT2
EUT Stage	Identical Prototype

Remark: The above EUT's information was declared by manufacturer. Please refer to the specifications or user's manual for more detailed description.

Accessory List	
WPC Cover	Brand Name : INCIPIO
	Model Name : MT-043-CASE



1.4 Product Specification of Equipment Under Test

Standards-related Product Specification			
Tx/Rx Channel Frequency Range	5180 MHz ~ 5240 MHz		
	5260 MHz ~ 5320 MHz		
	5500 MHz ~ 5700 MHz		
Type of Modulation	802.11a/n : OFDM (BPSK / QPSK / 16QAM / 64QAM) 802.11ac : OFDM (BPSK / QPSK / 16QAM / 64QAM / 256QAM)		
Antenna Type	Fixed Internal Antenna type (The antenna peak gain of EUT is less than 6 dBi)		
Antenna Function Description		Ant.1	Ant.2
	802.11 a/a/n/ac SISO	V	V
	802.11 a/n/ac MIMO	V	V

1.5 Modification of EUT

No modifications are made to the EUT during all test items.



1.6 Testing Location

Sporton Lab is accredited to ISO 17025 by Taiwan Accreditation Foundation (TAF code : 1190) and the FCC designation No. TW1022 under the FCC 2.948(e) by Mutual Recognition Agreement (MRA) in FCC Test.

Test Site	SPORTON INTERNATIONAL INC.	
Test Site Location	No. 52, Hwa Ya 1 st Rd., Hwa Ya Technology Park, Kwei-Shan District, Tao Yuan City, Taiwan, R.O.C. TEL: +886-3-327-3456 FAX: +886-3-328-4978	
Test Site No.	Sporton Site No.	
	CO05-HY	03CH07-HY

Note: The test site complies with ANSI C63.4 2014 requirement.

1.7 Applicable Standards

According to the specifications of the manufacturer, the EUT must comply with the requirements of the following standards:

- ♦ FCC Part 15 Subpart E
- ♦ FCC KDB 789033 D02 General UNII Test Procedures New Rules v01r02
- ♦ FCC KDB 662911 D01 Multiple Transmitter Output v02r01.
- ♦ FCC KDB 644545 D03 Guidance for IEEE 802 11ac New Rules v01
- ♦ KDB 648474 D03 Handset Wireless Chargers Battery Covers v01r04
- ♦ ANSI C63.10-2013

Remark:

1. All test items were verified and recorded according to the standards and without any deviation during the test.
2. This EUT has also been tested and complied with the requirements of FCC Part 15, Subpart B, recorded in a separate test report.



2 Test Configuration of Equipment Under Test

The EUT has been associated with peripherals and configuration operated in a manner tended to maximize its emission characteristics in a typical application. Frequency range investigated: conducted emission (150 kHz to 30 MHz) and radiated emission (9 kHz to the 10th harmonic of the highest fundamental frequency or to 40 GHz, whichever is lower). For radiated measurement, pre-scanned in three orthogonal panels, X, Y, Z. The worst cases (X plane) were recorded in this report.

The final configuration from all the combinations and the worst-case data rates were investigated by measuring the maximum power across all the data rates and modulation modes under section 2.2.

Based on the worst configuration found above, the RF power setting is set individually to meet FCC compliance limit for the final conducted and radiated tests shown in section 2.3.



2.1 Carrier Frequency and Channel

Frequency Band	Channel	Freq. (MHz)	Channel	Freq. (MHz)
5150-5250 MHz Band 1 (U-NII-1)	36	5180	44	5220
	38	5190	46	5230
	40	5200	48	5240
	42	5210		

Frequency Band	Channel	Freq. (MHz)	Channel	Freq. (MHz)
5250-5350 MHz Band 2 (U-NII-2A)	52	5260	60	5300
	54	5270	62	5310
	56	5280	64	5320
	58	5290		

Frequency Band	Channel	Freq. (MHz)	Channel	Freq. (MHz)
5470-5600 MHz and 5650-5725 MHz Band 3 (U-NII-2C)	100	5500	120	5600
	102	5510	122	5610
	104	5520	124	5620
	106	5530	126	5630
	108	5540	128	5640
	110	5550	132	5660
	112	5560	134	5670
	114	5570	136	5680
	116	5580	140	5700
118	5590			

Frequency Band	Channel	Freq. (MHz)	Channel	Freq. (MHz)
Straddle Channel	144	5720	142	5710
	138	5690		

Note: The above Frequency and Channel in boldface were 802.11n HT40.



2.2 Test Mode

Final test mode of conducted test items and radiated spurious emissions are considering the modulation and worse data rates from the power table described in section 2.2.

MIMO Antenna

Modulation	Data Rate
802.11ac VHT20	MCS0

Test Cases	
AC Conducted Emission	Mode 1 : GSM1900 Idle + Bluetooth Link + WLAN (5GHz) Link + Camera + WPC Back Cover + WPC Charging Pad + USB Cable (Charging from Adapter)
	Mode 2 : WCDMA Band V Idle + Bluetooth Link + WLAN (5GHz) Link + MPEG4 + WPC Back Cover + PMA Charging Pad + Adapter

Ch. #	Band III : 5470-5600 MHz and 5650-5725MHz	
	802.11ac VHT20	
L	Low	100
M	Middle	-
H	High	-
Straddle		-

2.3 Connection Diagram of Test System

<WLAN Tx with WPC Charging Mode>

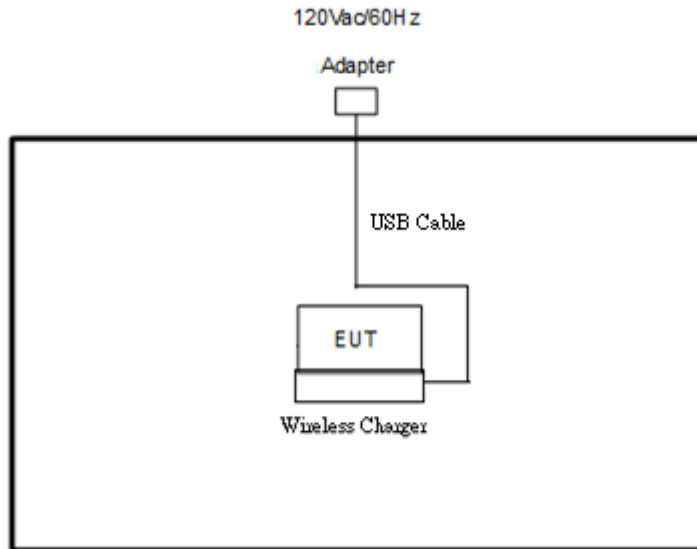

<WLAN Tx with PMA Charging Mode>

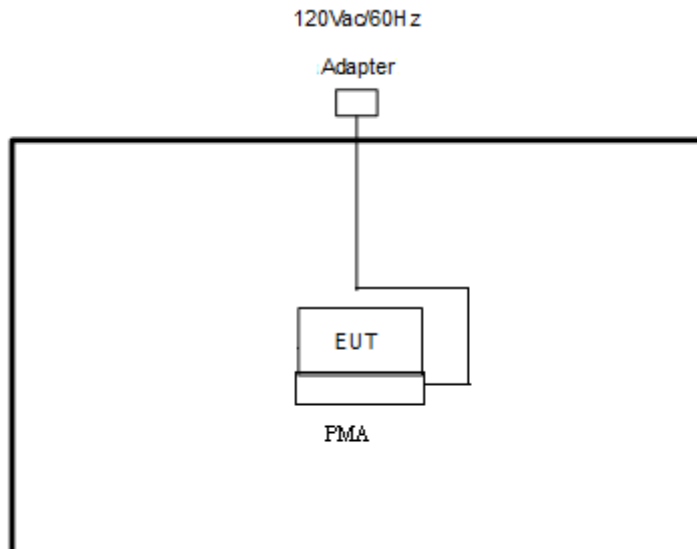

<AC Conducted Emission with WPC Charging Mode>

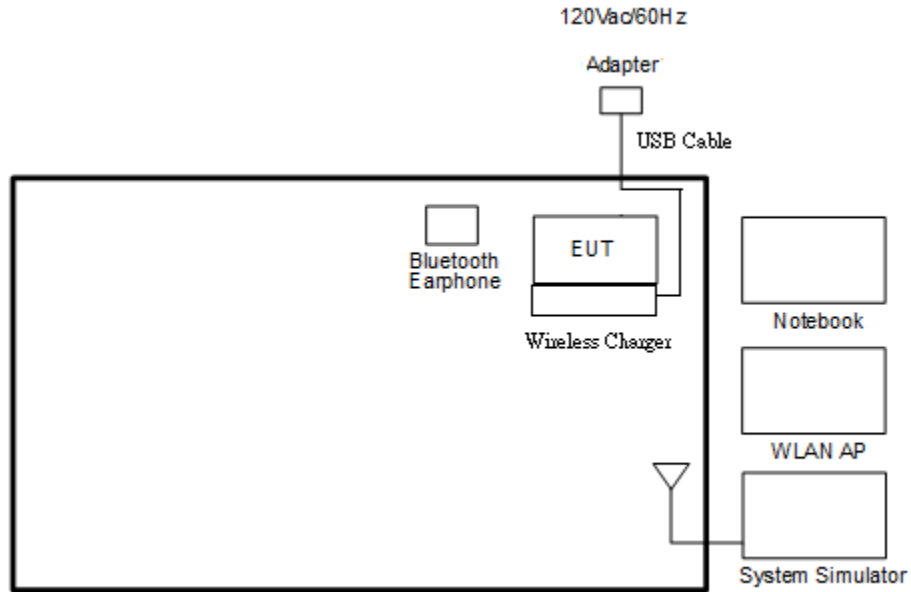

<AC Conducted Emission with PMA Charging Mode>

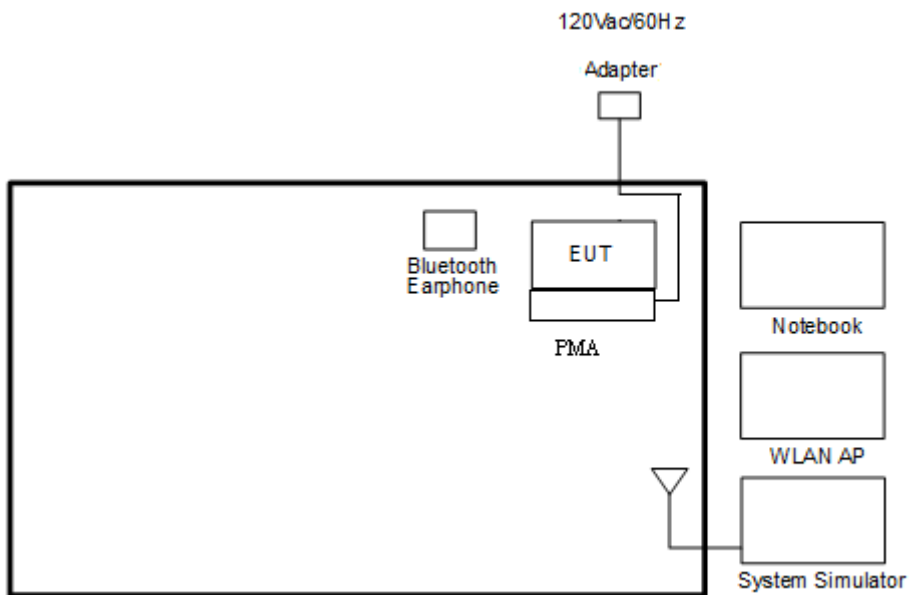



2.4 Support Unit used in test configuration and system

Item	Equipment	Trade Name	Model Name	FCC ID	Data Cable	Power Cord
1.	System Simulator	Anritsu	MT8820C	N/A	N/A	Unshielded, 1.8 m
2.	WLAN AP	D-Link	DIR-865L	KA2IR865LA1	N/A	Unshielded, 1.8 m
3.	Bluetooth Earphone	Sony Ericsson	MW600	PY7DDA-2029	N/A	N/A
4.	Notebook	DELL	Latitude E6320	FCC DoC/ Contains FCC ID: QDS-BRCM1054	N/A	AC I/P: Unshielded, 1.2 m DC O/P: Shielded, 1.8 m
5.	SD Card	SanDisk	MicroSD HC	FCC DoC	N/A	N/A
6.	Wireless Charger	LG	WCD-100	FCC DoC	N/A	N/A
7.	PMA	DURACELL	M-018B-518A	FCC DoC	N/A	N/A
8.	USB Cable	Motorola	SKN6461A	N/A	Unshielded, 1.0 m	N/A
9.	Adapter	Motorola	SPN5865A	N/A	N/A	N/A

2.5 EUT Operation Test Setup

For WLAN function, programmed RF utility, "QRCT" installed in the notebook make the EUT provide functions like channel selection and power level for continuous transmitting and receiving signals.



3 Test Result

3.1 Unwanted Emissions Measurement

This section as specified in FCC Part 15.407(b) is to measure unwanted emissions through radiated measurement for band edge spurious emissions and out of band emissions measurement. The unwanted emissions shall comply with 15.407(b)(1) to (6), and restricted bands per FCC Part15.205.

3.1.1 Limit of Unwanted Emissions

(1) For transmitters operating in the 5150-5250 MHz band: all emissions outside of the 5150-5350 MHz band shall not exceed an EIRP of -27dBm/MHz.

For transmitters operating in the 5250-5350 MHz band: all emissions outside of the 5150-5350 MHz band shall not exceed an EIRP of -27 dBm/MHz. Devices operating in the 5250-5350 MHz band that generate emissions in the 5150-5250 MHz band must meet all applicable technical requirements for operation in the 5150-5250 MHz band (including indoor use) or alternatively meet an out-of-band emission EIRP limit of -27 dBm/MHz in the 5150-5250 MHz band. For transmitters operating in the 5470-5600 MHz and 5650-5725MHz band: all emissions outside of the 5470-5600 MHz and 5650-5725MHz band shall not exceed an EIRP of -27 dBm/MHz.

(2) Unwanted spurious emissions fallen in restricted bands per FCC Part15.205 shall comply with the general field strength limits set forth in § 15.209 as below table,

Frequency (MHz)	Field Strength (microvolts/meter)	Measurement Distance (meters)
0.009 – 0.490	2400/F(kHz)	300
0.490 – 1.705	24000/F(kHz)	30
1.705 – 30.0	30	30
30 – 88	100	3
88 – 216	150	3
216 - 960	200	3
Above 960	500	3

Note: The following formula is used to convert the EIRP to field strength.

$$E = \frac{1000000\sqrt{30P}}{3} \mu\text{V/m, where P is the eirp (Watts)}$$

EIRP (dBm)	Field Strength at 3m (dBµV/m)
-17	78.3
- 27	68.3



- (3) KDB789033 D02 v01r02 G)2)c) As specified in 15.407(b), emissions above 1000 MHz that are outside of the restricted bands are subject to a peak emission limit of -27 dBm/MHz (or -17 dBm/MHz as specified in 15.407(b)(4)). However, an out-of-band emission that complies with both the average and peak limits of 15.209 is not required to satisfy the -27 dBm/MHz or -17 dBm/MHz peak emission limit.

3.1.2 Measuring Instruments

The measuring equipment is listed in the section 4 of this test report.

3.1.3 Test Procedures

1. The testing follows FCC KDB 789033 D02 General UNII Test Procedures New Rules v01r02. Section G) Unwanted emissions measurement.
 - (1) Procedure for Unwanted Emissions Measurements Below 1000MHz
 - RBW = 120 kHz
 - VBW = 300 kHz
 - Detector = Peak
 - Trace mode = max hold
 - (2) Procedure for Peak Unwanted Emissions Measurements Above 1000 MHz
 - RBW = 1 MHz
 - VBW \geq 3 MHz
 - Detector = Peak
 - Sweep time = auto
 - Trace mode = max hold
 - (3) Procedures for Average Unwanted Emissions Measurements Above 1000MHz
 - RBW = 1 MHz
 - VBW = 10 Hz, when duty cycle is no less than 98 percent.
 - VBW \geq 1/T, when duty cycle is less than 98 percent where T is the minimum transmission duration over which the transmitter is on and is transmitting at its maximum power control level for the tested mode of operation.
2. The EUT was placed on a turntable with 0.8 meter for frequency below 1GHz and 1.5 meter for frequency above 1GHz respectively above ground.
3. The EUT was set 3 meters from the interference receiving antenna which was mounted on the top of a variable height antenna tower.
4. The antenna is a broadband antenna and its height is adjusted between one meter and four meters above ground to find the maximum value of the field strength for both horizontal polarization and vertical polarization of the antenna.

5. For each suspected emission, the EUT was arranged to its worst case and then adjust the antenna tower (from 1 m to 4 m) and turntable (from 0 degree to 360 degrees) to find the maximum reading.
6. For testing below 1GHz, if the emission level of the EUT in peak mode was 3 dB lower than the limit specified, then peak values of EUT will be reported, otherwise, the emissions will be repeated one by one using the CISPR quasi-peak method and reported.
7. For testing above 1GHz, the emission level of the EUT in peak mode was 20dB lower than average limit (that means the emission level in average mode also complies with the limit in average mode), then peak values of EUT will be reported, otherwise, the emissions will be measured in average mode again and reported.

3.1.4 Test Setup

For radiated emissions below 30MHz

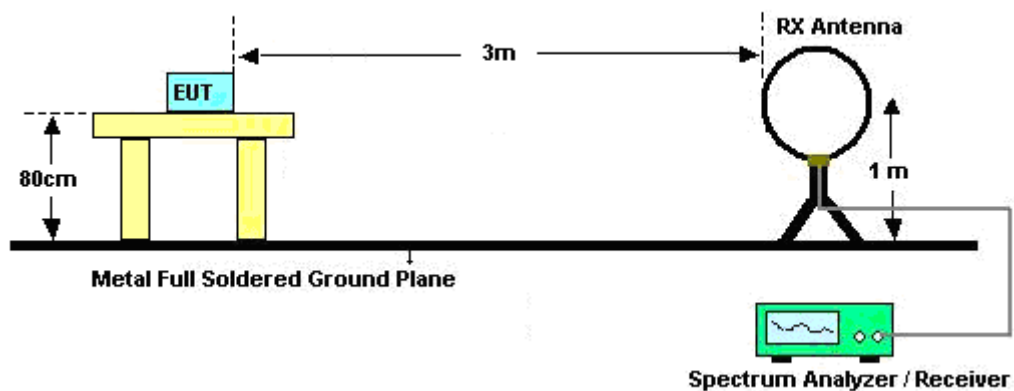

For radiated emissions from 30MHz to 1GHz

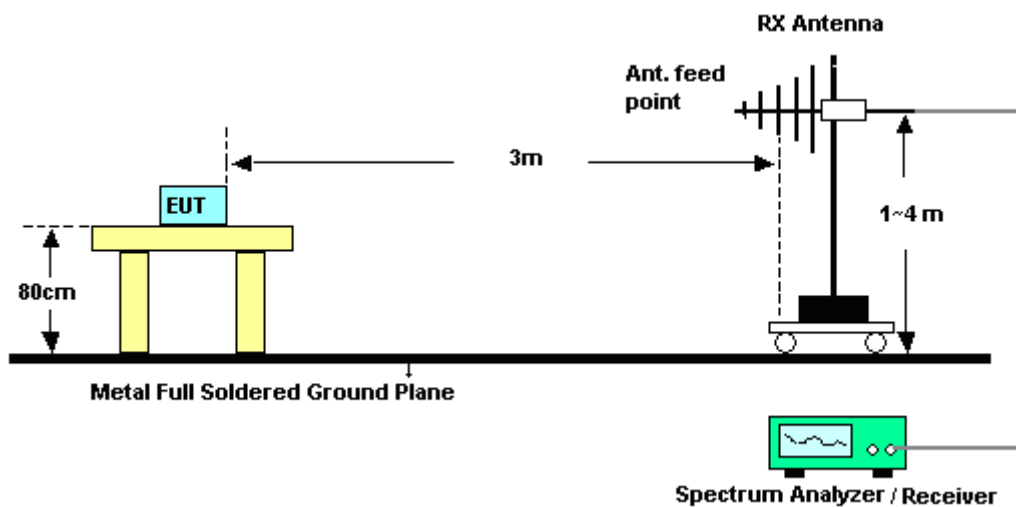

For radiated emissions above 1GHz

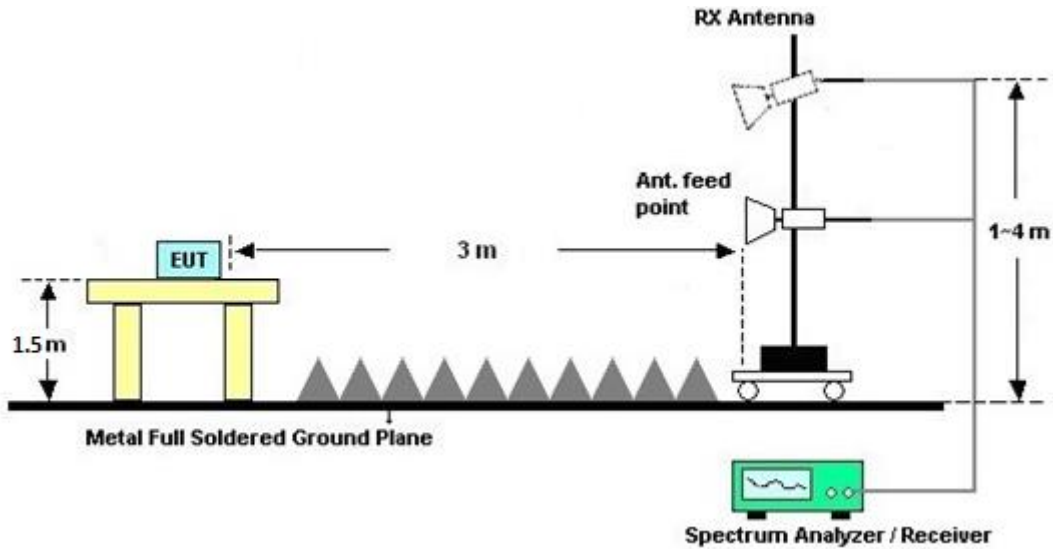

3.1.5 Test Results of Radiated Emissions (9 kHz ~ 30 MHz)

The low frequency, which started from 9 kHz to 30MHz, was pre-scanned and the result which was 20dB lower than the limit line per 15.31(o) was not reported.

3.1.6 Test Result of Radiated Band Edges

Please refer to Appendix A and B

3.1.7 Duty Cycle

Please refer to Appendix C.

3.1.8 Test Result of Unwanted Radiated Emission (30MHz ~ 10th Harmonic)

Please refer to Appendix A and B



3.2 AC Conducted Emission Measurement

3.2.1 Limit of AC Conducted Emission

For equipment that is designed to be connected to the public utility (AC) power line, the radio frequency voltage that is conducted back onto the AC power line on any frequency or frequencies within the band 150 kHz to 30 MHz shall not exceed the limits in the following table.

Frequency of emission (MHz)	Conducted limit (dB μ V)	
	Quasi-peak	Average
0.15-0.5	66 to 56*	56 to 46*
0.5-5	56	46
5-30	60	50

*Decreases with the logarithm of the frequency.

3.2.2 Measuring Instruments

The measuring equipment is listed in the section 4 of this test report.

3.2.3 Test Procedures

1. The EUT was placed 0.4 meter from the conducting wall of the shielding room was kept at least 80 centimeters from any other grounded conducting surface.
2. Connect EUT to the power mains through a line impedance stabilization network (LISN).
3. All the support units are connecting to the other LISN.
4. The LISN provides 50 ohm coupling impedance for the measuring instrument.
5. The FCC states that a 50 ohm, 50 microhenry LISN should be used.
6. Both sides of AC line were checked for maximum conducted interference.
7. The frequency range from 150 kHz to 30 MHz was searched.
8. Set the test-receiver system to Peak Detect Function and specified bandwidth with Maximum Hold Mode.

3.2.4 Test Setup

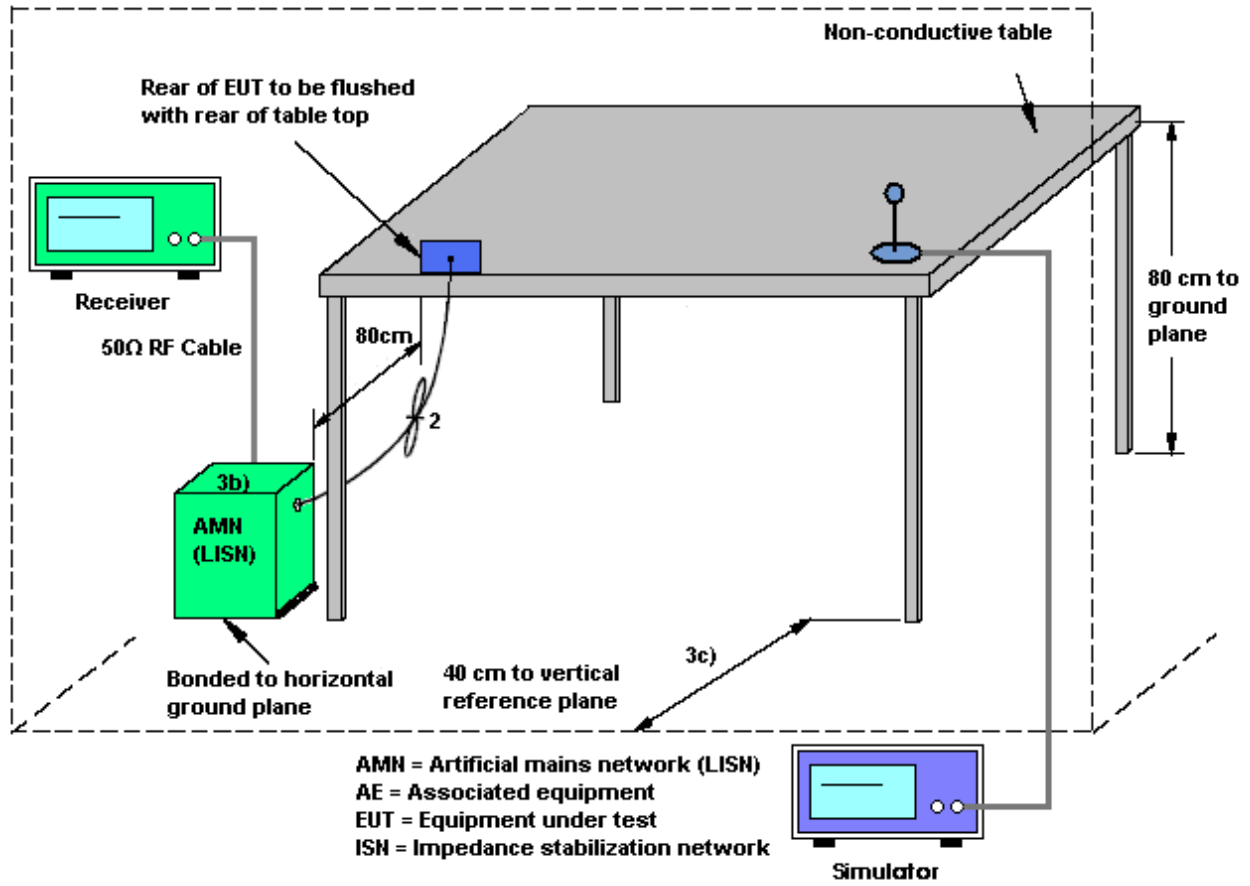



3.2.5 Test Result of AC Conducted Emission

Test Mode :	Mode 2	Temperature :	23~24°C
Test Engineer :	Kai-Chun Chu	Relative Humidity :	44~45%
Test Voltage :	120Vac / 60Hz	Phase :	Line
Function Type :	WCDMA Band V Idle + Bluetooth Link + WLAN (5GHz) Link + MPEG4 + WPC Back Cover + PMA Charging Pad + Adapter		

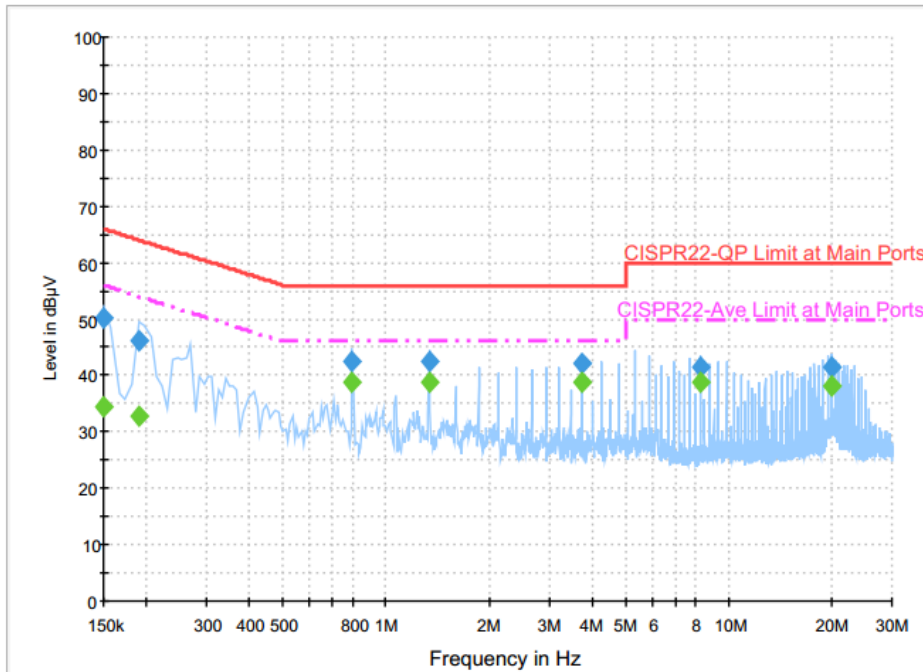

Final Result : QuasiPeak

Frequency (MHz)	QuasiPeak (dBµV)	Filter	Line	Corr. (dB)	Margin (dB)	Limit (dBµV)
0.150000	50.2	Off	L1	19.6	15.8	66.0
0.190000	46.2	Off	L1	19.6	17.8	64.0
0.798000	42.4	Off	L1	19.6	13.6	56.0
1.334000	42.3	Off	L1	19.7	13.7	56.0
3.734000	42.1	Off	L1	19.8	13.9	56.0
8.270000	41.5	Off	L1	20.0	18.5	60.0
20.006000	41.5	Off	L1	20.7	18.5	60.0

Final Result : Average

Frequency (MHz)	Average (dBµV)	Filter	Line	Corr. (dB)	Margin (dB)	Limit (dBµV)
0.150000	34.3	Off	L1	19.6	21.7	56.0
0.190000	32.7	Off	L1	19.6	21.3	54.0
0.798000	38.9	Off	L1	19.6	7.1	46.0
1.334000	38.8	Off	L1	19.7	7.2	46.0
3.734000	38.7	Off	L1	19.8	7.3	46.0
8.270000	38.8	Off	L1	20.0	11.2	50.0
20.006000	38.2	Off	L1	20.7	11.8	50.0



Test Mode :	Mode 2	Temperature :	23~24°C
Test Engineer :	Kai-Chun Chu	Relative Humidity :	44~45%
Test Voltage :	120Vac / 60Hz	Phase :	Neutral
Function Type :	WCDMA Band V Idle + Bluetooth Link + WLAN (5GHz) Link + MPEG4 + WPC Back Cover + PMA Charging Pad + Adapter		

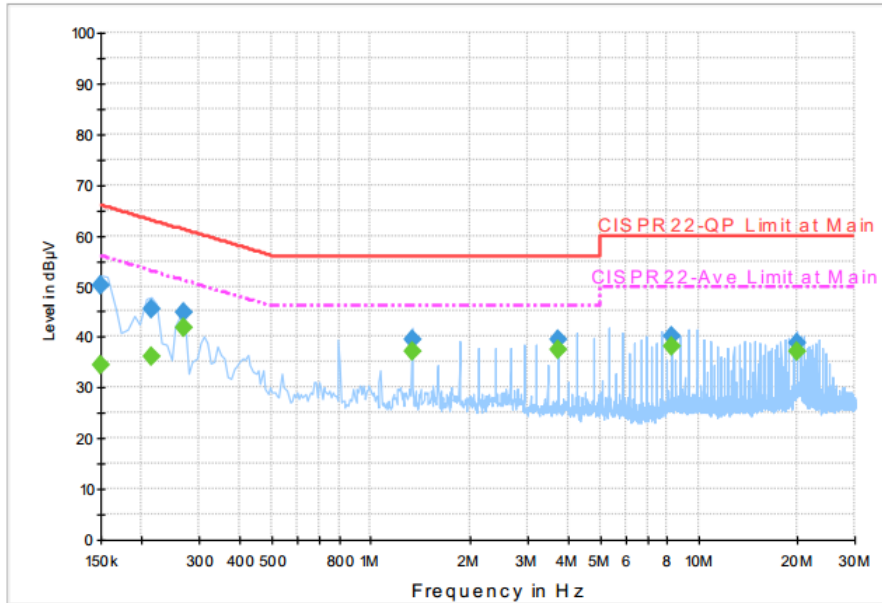

Final Result : QuasiPeak

Frequency (MHz)	QuasiPeak (dBµV)	Filter	Line	Corr. (dB)	Margin (dB)	Limit (dBµV)
0.150000	50.3	Off	N	19.6	15.7	66.0
0.214000	45.4	Off	N	19.6	17.6	63.0
0.270000	44.8	Off	N	19.6	16.3	61.1
1.334000	39.4	Off	N	19.6	16.6	56.0
3.734000	39.5	Off	N	19.7	16.5	56.0
8.270000	40.1	Off	N	20.0	19.9	60.0
20.006000	38.7	Off	N	20.8	21.3	60.0

Final Result : Average

Frequency (MHz)	Average (dBµV)	Filter	Line	Corr. (dB)	Margin (dB)	Limit (dBµV)
0.150000	34.5	Off	N	19.6	21.5	56.0
0.214000	36.1	Off	N	19.6	16.9	53.0
0.270000	41.7	Off	N	19.6	9.4	51.1
1.334000	37.3	Off	N	19.6	8.7	46.0
3.734000	37.5	Off	N	19.7	8.5	46.0
8.270000	38.2	Off	N	20.0	11.8	50.0
20.006000	37.1	Off	N	20.8	12.9	50.0



4 List of Measuring Equipment

Instrument	Manufacturer	Model No.	Serial No.	Characteristics	Calibration Date	Test Date	Due Date	Remark
AC Power Source	ChainTek	APC-1000W	N/A	N/A	N/A	May 22, 2016	N/A	Conduction (CO05-HY)
EMI Test Receiver	Rohde & Schwarz	ESCI 7	100724	9kHz~7GHz	Aug. 26, 2015	May 22, 2016	Aug. 25, 2016	Conduction (CO05-HY)
LISN	Rohde & Schwarz	ENV216	100080	9kHz~30MHz	Dec. 02, 2015	May 22, 2016	Dec. 01, 2016	Conduction (CO05-HY)
Bilog Antenna	TESEQ	CBL 6111D	35419	30MHz to 1GHz	Jan. 13, 2016	May 19, 2016 ~ May 21, 2016	Jan. 12, 2017	Radiation (03CH07-HY)
Double Ridge Horn Antenna	ESCO	3117	00075962	1GHz ~ 18GHz	Aug. 21, 2015	May 19, 2016 ~ May 21, 2016	Aug. 20, 2016	Radiation (03CH07-HY)
EMI Test Receiver	Keysight	N9038A(MXE)	MY54130085	20Hz ~ 8.4GHz	Nov. 04, 2015	May 19, 2016 ~ May 21, 2016	Nov. 03, 2016	Radiation (03CH07-HY)
Loop Antenna	Rohde & Schwarz	HFH2-Z2	100315	9 kHz~30 MHz	Sep. 02, 2015	May 19, 2016 ~ May 21, 2016	Sep. 01, 2016	Radiation (03CH07-HY)
Preamplifier	MITEQ	AMF-7D-0010 1800-30-10P	1590075	1GHz ~ 18GHz	Apr. 15, 2016	May 19, 2016 ~ May 21, 2016	Apr. 14, 2017	Radiation (03CH07-HY)
Preamplifier	COM-POWER	PA-103A	161241	10MHz-1GHz	Mar. 18, 2016	May 19, 2016 ~ May 21, 2016	Mar. 17, 2017	Radiation (03CH07-HY)
Preamplifier	Agilent	8449B	3008A02362	1GHz~ 26.5GHz	Oct. 19, 2015	May 19, 2016 ~ May 21, 2016	Oct. 18, 2016	Radiation (03CH07-HY)
Spectrum Analyzer	Agilent	N9010A	MY53470118	10Hz~44GHz	Feb. 27, 2016	May 19, 2016 ~ May 21, 2016	Feb. 26, 2017	Radiation (03CH07-HY)
Controller	ChainTek	Chaintek 3000	N/A	Control Turn table	N/A	May 19, 2016 ~ May 21, 2016	N/A	Radiation (03CH07-HY)
Controller	Max-Full	MF7802	MF78020836 8	Control Ant Mast	N/A	May 19, 2016 ~ May 21, 2016	N/A	Radiation (03CH07-HY)
Antenna Mast	Max-Full	MFA520BS	N/A	1m~4m	N/A	May 19, 2016 ~ May 21, 2016	N/A	Radiation (03CH07-HY)
Turn Table	ChainTek	Chaintek 3000	N/A	0~360 Degree	N/A	May 19, 2016 ~ May 21, 2016	N/A	Radiation (03CH07-HY)
Preamplifier	MITEQ	JS44-1800400 0-33-8P	1840917	18GHz ~ 40GHz	Jun. 02, 2015	May 19, 2016 ~ May 21, 2016	Jun. 01, 2016	Radiation (03CH07-HY)
SHF-EHF Horn Antenna	SCHWARZBECK	BBHA 9170	BBHA917058 4	18GHz- 40GHz	Nov. 02, 2015	May 19, 2016 ~ May 21, 2016	Nov. 01, 2016	Radiation (03CH07-HY)



5 Uncertainty of Evaluation

Uncertainty of Conducted Emission Measurement (150kHz ~ 30MHz)

Measuring Uncertainty for a Level of Confidence of 95% ($U = 2Uc(y)$)	2.26
---	------

Uncertainty of Radiated Emission Measurement (30 MHz ~ 1000 MHz)

Measuring Uncertainty for a Level of Confidence of 95% ($U = 2Uc(y)$)	5.60
---	------



Appendix A. Radiated Spurious Emission

Test Engineer :	Jesse Wang, James Chiu, and Kyle Chuang	Temperature :	21~23°C
		Relative Humidity :	55~58%

Band 3 - 5470~5725MHz

WIFI 802.11ac VHT20 (Band Edge @ 3m)

<PMA Charging Mode>

WIFI Ant.	Note	Frequency	Level	Over Limit	Limit Line	Read Level	Antenna Factor	Cable Loss	Preamp Factor	Ant Pos	Table Pos	Peak Avg.	Pol.	
1+2		(MHz)	(dBμV/m)	(dB)	(dBμV/m)	(dBμV)	(dB/m)	(dB)	(dB)	(cm)	(deg)	(P/A)	(H/V)	
802.11ac VHT20 CH 100 5500MHz		5458.64	58.63	-15.37	74	46.6	35.38	11.89	35.24	100	45	P	H	
		5466.64	64.83	-3.47	68.3	52.76	35.42	11.89	35.24	100	45	P	H	
		5459.89	50.99	-3.01	54	38.96	35.38	11.89	35.24	100	45	A	H	
	*	5500	105.07	-	-	92.92	35.5	11.89	35.24	100	45	P	H	
		5500	98	-	-	85.85	35.5	11.89	35.24	100	45	A	H	
														H
			5459.12	59.57	-14.43	74	47.54	35.38	11.89	35.24	273	285	P	V
			5468.4	67.22	-1.08	68.3	55.15	35.42	11.89	35.24	273	285	P	V
			5460	52.62	-1.38	54	40.59	35.38	11.89	35.24	273	285	A	V
	*	5500	105.94	-	-	93.79	35.5	11.89	35.24	273	285	P	V	
		5500	100.07	-	-	87.92	35.5	11.89	35.24	273	285	A	V	
													V	
Remark	1. No other spurious found. 2. All results are PASS against Peak and Average limit line.													



Band 3 - 5470~5725MHz

WIFI 802.11ac VHT20 (Band Edge @ 3m)

<WPC Charging Mode>

WIFI Ant.	Note	Frequency	Level	Over Limit	Limit Line	Read Level	Antenna Factor	Cable Loss	Preamp Factor	Ant Pos	Table Pos	Peak Avg.	Pol.	
1+2		(MHz)	(dBμV/m)	(dB)	(dBμV/m)	(dBμV)	(dB/m)	(dB)	(dB)	(cm)	(deg)	(P/A)	(H/V)	
802.11ac VHT20 CH 100 5500MHz		5459.8	58.26	-15.74	74	46.23	35.38	11.89	35.24	233	239	P	H	
		5468.24	62.91	-5.39	68.3	50.84	35.42	11.89	35.24	233	239	P	H	
		5460	48.12	-5.88	54	36.09	35.38	11.89	35.24	233	239	A	H	
	*	5500	100.74	-	-	88.59	35.5	11.89	35.24	233	239	P	H	
		5500	94.29	-	-	82.14	35.5	11.89	35.24	233	239	A	H	
														H
			5458.64	56.7	-17.3	74	44.67	35.38	11.89	35.24	248	1	P	V
			5470	61.78	-6.52	68.3	49.71	35.42	11.89	35.24	248	1	P	V
			5457.91	48.66	-5.34	54	36.63	35.38	11.89	35.24	248	1	A	V
	*		5500	103.76	-	-	91.61	35.5	11.89	35.24	248	1	P	V
			5500	97.51	-	-	85.36	35.5	11.89	35.24	248	1	A	V
													V	
Remark	3. No other spurious found. 4. All results are PASS against Peak and Average limit line.													



Band 3 - 5470~5725MHz
WIFI 802.11ac VHT20 (Harmonic @ 3m)

<PMA Charging Mode>

WIFI Ant. 1+2	Note	Frequency (MHz)	Level (dBμV/m)	Over Limit (dB)	Limit Line (dBμV/m)	Read Level (dBμV)	Antenna Factor (dB/m)	Cable Loss (dB)	Preamp Factor (dB)	Ant Pos (cm)	Table Pos (deg)	Peak Avg. (P/A)	Pol. (H/V)	
802.11ac VHT20 CH 100 5500MHz		11000	52.32	-21.68	74	55.65	37.9	17.17	58.4	100	177	P	H	
		11000	42.46	-11.54	54	45.79	37.9	17.17	58.4	100	177	A	H	
		16500	46.43	-21.87	68.3	40.7	41.6	20.23	56.1	100	0	P	H	
													H	
			11000	57.46	-16.54	74	60.79	37.9	17.17	58.4	133	25	P	V
			11000	47.75	-6.25	54	51.08	37.9	17.17	58.4	133	25	A	V
			16500	52.66	-15.64	68.3	46.93	41.6	20.23	56.1	100	0	P	V
													V	
Remark	1. No other spurious found. 2. All results are PASS against Peak and Average limit line.													



Band 3 - 5470~5725MHz
WIFI 802.11ac VHT20 (Harmonic @ 3m)

<WPC Charging Mode>

WIFI Ant. 1+2	Note	Frequency (MHz)	Level (dBμV/m)	Over Limit (dB)	Limit Line (dBμV/m)	Read Level (dBμV)	Antenna Factor (dB/m)	Cable Loss (dB)	Preamp Factor (dB)	Ant Pos (cm)	Table Pos (deg)	Peak Avg. (P/A)	Pol. (H/V)	
802.11ac VHT20 CH 100 5500MHz		11000	55.75	-18.25	74	59.08	37.9	17.17	58.4	100	117	P	H	
		11000	45.93	-8.07	54	49.26	37.9	17.17	58.4	100	117	A	H	
		16500	50.42	-17.88	68.3	44.69	41.6	20.23	56.1	100	0	P	H	
													H	
			11000	56.41	-17.59	74	59.74	37.9	17.17	58.4	121	165	P	V
			11000	46.55	-7.45	54	49.88	37.9	17.17	58.4	121	165	A	V
			16500	49.42	-18.88	68.3	43.69	41.6	20.23	56.1	100	0	P	V
													V	
Remark	3. No other spurious found. 4. All results are PASS against Peak and Average limit line.													



**Band 3 - 5470~5725MHz
Emission below 1GHz
WIFI 802.11ac (LF @ 3m)**

<PMA Charging Mode>

WIFI Ant. 1+2	Note	Frequency (MHz)	Level (dBμV/m)	Over Limit (dB)	Limit Line (dBμV/m)	Read Level (dBμV)	Antenna Factor (dB/m)	Cable Loss (dB)	Preamp Factor (dB)	Ant Pos (cm)	Table Pos (deg)	Peak Avg. (P/A)	Pol. (H/V)	
802.11ac LF		57.81	25.31	-14.69	40	43.21	12.62	1.07	31.59			P	H	
		177.15	26.53	-16.97	43.5	40.68	15.56	1.78	31.49			P	H	
		254.1	21.99	-24.01	46	31.89	19.4	2.07	31.37			P	H	
		706.7	29.14	-16.86	46	29.6	26.51	3.74	30.71			P	H	
		851.6	32.35	-13.65	46	30.1	28.71	4.1	30.56	100	0	P	H	
		964.3	33.77	-20.23	54	30	30.23	4.07	30.53			P	H	
														H
														H
														H
														H
														H
														H
			56.19	35.82	-4.18	40	53.1	13.24	1.07	31.59	100	0	P	V
			85.89	28.19	-11.81	40	43.83	14.62	1.28	31.54			P	V
			196.86	32.5	-11	43.5	46.26	15.85	1.87	31.48			P	V
			767.6	30.52	-15.48	46	29.96	27.37	3.82	30.63			P	V
			874	32.48	-13.52	46	30.02	28.84	4.17	30.55			P	V
			983.9	34.9	-19.1	54	31.17	30.27	3.98	30.52			P	V
														V
														V
													V	
													V	
													V	
													V	
Remark	1. No other spurious found. 2. All results are PASS against limit line.													



**Band 3 - 5470~5725MHz
Emission below 1GHz
WIFI 802.11ac (LF @ 3m)**

<WPC Charging Mode>

WIFI Ant. 1+2	Note	Frequency (MHz)	Level (dBμV/m)	Over Limit (dB)	Limit Line (dBμV/m)	Read Level (dBμV)	Antenna Factor (dB/m)	Cable Loss (dB)	Preamp Factor (dB)	Ant Pos (cm)	Table Pos (deg)	Peak Avg. (P/A)	Pol. (H/V)	
802.11ac LF		30	27.6	-12.4	40	31.88	26	1.07	31.35			P	H	
		185.25	33.1	-10.4	43.5	47.27	15.45	1.87	31.49	100	0	P	H	
		222.51	24.97	-21.03	46	37.77	16.56	2.07	31.43			P	H	
		853	32.17	-13.83	46	29.91	28.72	4.1	30.56			P	H	
		894.3	32.61	-13.39	46	30.01	28.97	4.17	30.54			P	H	
		930	33.73	-12.27	46	30.41	29.73	4.12	30.53			P	H	
														H
														H
														H
														H
														H
														H
			53.76	30.07	-9.93	40	46.42	14.17	1.07	31.59			P	V
			187.14	38.36	-5.14	43.5	52.51	15.47	1.87	31.49	100	0	P	V
			281.1	22.15	-23.85	46	31.8	19.34	2.32	31.31			P	V
			793.5	31	-15	46	30.07	27.63	3.9	30.6			P	V
			839	31.81	-14.19	46	29.8	28.48	4.1	30.57			P	V
			892.2	33.72	-12.28	46	31.14	28.95	4.17	30.54			P	V
													V	
													V	
													V	
													V	
													V	
Remark	3. No other spurious found. 4. All results are PASS against limit line.													



Note symbol

*	Fundamental Frequency which can be ignored. However, the level of any unwanted emissions shall not exceed the level of the fundamental frequency.
!	Test result is over limit line.
P/A	Peak or Average
H/V	Horizontal or Vertical



A calculation example for radiated spurious emission is shown as below:

WIFI	Note	Frequency	Level	Over	Limit	Read	Antenna	Cable	Preamp	Ant	Table	Peak	Pol.
Ant.				Limit	Line	Level	Factor	Loss	Factor	Pos	Pos	Avg.	
1+2		(MHz)	(dBμV/m)	(dB)	(dBμV/m)	(dBμV)	(dB/m)	(dB)	(dB)	(cm)	(deg)	(P/A)	(H/V)
802.11b		2390	55.45	-18.55	74	54.51	32.22	4.58	35.86	103	308	P	H
CH 01													
2412MHz		2390	43.54	-10.46	54	42.6	32.22	4.58	35.86	103	308	A	H

- 1. Level(dBμV/m) =
Antenna Factor(dB/m) + Cable Loss(dB) + Read Level(dBμV) - Preamp Factor(dB)
- 2. Over Limit(dB) = Level(dBμV/m) – Limit Line(dBμV/m)

For Peak Limit @ 2390MHz:

- 1. Level(dBμV/m)
= Antenna Factor(dB/m) + Cable Loss(dB) + Read Level(dBμV) - Preamp Factor(dB)
= 32.22(dB/m) + 4.58(dB) + 54.51(dBμV) – 35.86 (dB)
= 55.45 (dBμV/m)
- 2. Over Limit(dB)
= Level(dBμV/m) – Limit Line(dBμV/m)
= 55.45(dBμV/m) – 74(dBμV/m)
= -18.55(dB)

For Average Limit @ 2390MHz:

- 1. Level(dBμV/m)
= Antenna Factor(dB/m) + Cable Loss(dB) + Read Level(dBμV) - Preamp Factor(dB)
= 32.22(dB/m) + 4.58(dB) + 42.6(dBμV) – 35.86 (dB)
= 43.54 (dBμV/m)
- 2. Over Limit(dB)
= Level(dBμV/m) – Limit Line(dBμV/m)
= 43.54(dBμV/m) – 54(dBμV/m)
= -10.46(dB)

Both peak and average measured complies with the limit line, so test result is “PASS”.



Appendix B. Radiated Spurious Emission

Test Engineer :	Jesse Wang, James Chiu, and Kyle Chuang	Temperature :	21~23°C
		Relative Humidity :	55~58%

Note symbol

-L	Low channel location
-R	High channel location



Band 3 - 5470~5725MHz

WIFI 802.11ac VHT20 (Band Edge @ 3m)

<PMA Charging Mode>

WIFI	Band 3 5470~5725MHz Band Edge @ 3m	
ANT	802.11ac VHT20 CH100 5500MHz	
1+2	Horizontal	Vertical
Peak	<p>Site : 03CH07-HY Condition : FCC PART15E 3m HF-ANT_130829 HORIZONTAL RBW: 1000.000kHz VSW: 3000.000kHz SWT: Auto Detector : Peak Project : 640145-06 Mode : 1</p>	<p>Site : 03CH07-HY Condition : FCC PART15E 3m HF-ANT_130829 VERTICAL RBW: 1000.000kHz VSW: 3000.000kHz SWT: Auto Detector : Peak Project : 640145-06 Mode : 1</p>
Avg.	<p>Site : 03CH07-HY Condition : FCC PART15E (AVG) 3m HF-ANT_130829 HORIZONTAL RBW: 1000.000kHz VSW: 1.000kHz SWT: Auto Detector : Peak Project : 640145-06 Mode : 1</p>	<p>Site : 03CH07-HY Condition : FCC PART15E (AVG) 3m HF-ANT_130829 VERTICAL RBW: 1000.000kHz VSW: 1.000kHz SWT: Auto Detector : Peak Project : 640145-06 Mode : 1</p>



WIFI	Band 3 5470~5725MHz Fundamental @ 3m	
ANT	802.11ac VHT20 CH100 5500MHz	
1+2	Horizontal	Vertical
Peak Avg	<p>Site : 03CH07.HY Condition : FCC PART15E 3m HF-ANT_130829 HORIZONTAL Detector : Peak Project : 640145-06 Mode : 1</p>	<p>Site : 03CH07.HY Condition : FCC PART15E 3m HF-ANT_130829 VERTICAL Detector : Peak Project : 640145-06 Mode : 1</p>



Band 3 - 5470~5725MHz

WIFI 802.11ac VHT20 (Band Edge @ 3m)

<WPC Charging Mode>

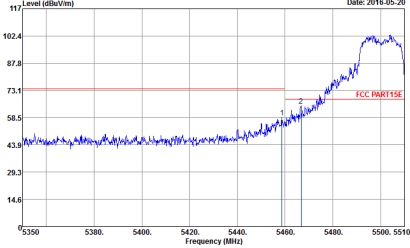
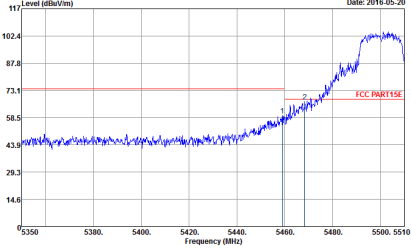
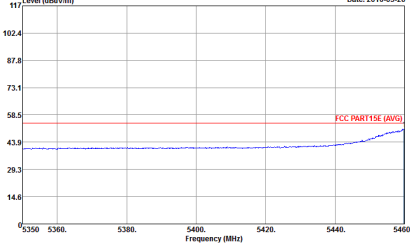
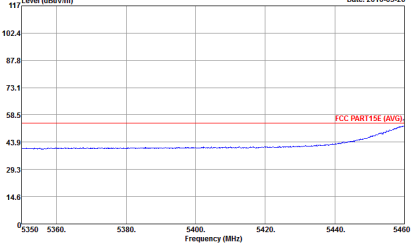
WIFI	Band 3 5470~5725MHz Band Edge @ 3m	
ANT	802.11ac VHT20 CH100 5500MHz	
1+2	Horizontal	Vertical
Peak	 <p>Site : 03CH07-HY Condition : FCC PART15E 3m HF-ANT_130829 HORIZONTAL RBW: 1000.000kHz VBW: 3000.000kHz SWT: Auto Detector : Peak Project : 640145-06 Mode : 1</p>	 <p>Site : 03CH07-HY Condition : FCC PART15E 3m HF-ANT_130829 VERTICAL RBW: 1000.000kHz VBW: 3000.000kHz SWT: Auto Detector : Peak Project : 640145-06 Mode : 1</p>
Avg.	 <p>Site : 03CH07-HY Condition : FCC PART15E (AVG) 3m HF-ANT_130829 HORIZONTAL RBW: 1000.000kHz VBW: 1.000kHz SWT: Auto Detector : Peak Project : 640145-06 Mode : 1</p>	 <p>Site : 03CH07-HY Condition : FCC PART15E (AVG) 3m HF-ANT_130829 VERTICAL RBW: 1000.000kHz VBW: 1.000kHz SWT: Auto Detector : Peak Project : 640145-06 Mode : 1</p>

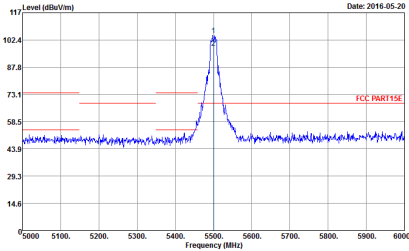
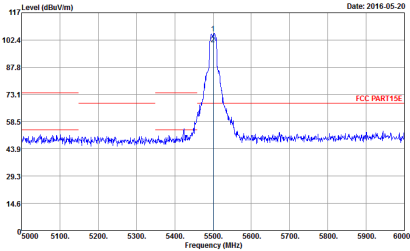

WIFI	Band 3 5470~5725MHz Fundamental @ 3m	
ANT	802.11ac VHT20 CH100 5500MHz	
1+2	Horizontal	Vertical
Peak Avg	 <p data-bbox="347 745 758 813"> Date: 2016-05-20 Site : 03CH07.HY Condition : FCC PART15E 3m HF-ANT_130829 HORIZONTAL Detector : Peak Project : 640145-06 Mode : 1 </p>	 <p data-bbox="944 745 1355 813"> Date: 2016-05-20 Site : 03CH07.HY Condition : FCC PART15E 3m HF-ANT_130829 VERTICAL Detector : Peak Project : 640145-06 Mode : 1 </p>



Band 3 - 5470~5725MHz

WIFI 802.11ac VHT20 (Harmonic @ 3m)

<PMA Charging Mode>

WIFI	Band 3 5470~5725MHz Harmonic @ 3m	
ANT	802.11ac VHT20 CH100 5500MHz	
1+2	Horizontal	Vertical
Peak Avg.	<p>Site : 03CH07.HY Condition : FCC PART 15E_BAND4 3m HF-ANT_130829 HORIZONTAL Detector : Peak Project : 640145-06 Mode : 1</p>	<p>Site : 03CH07.HY Condition : FCC PART 15E_BAND4 3m HF-ANT_130829 VERTICAL Detector : Peak Project : 640145-06 Mode : 1</p>



Band 3 - 5470~5725MHz

WIFI 802.11ac VHT20 (Harmonic @ 3m)

<WPC Charging Mode>

WIFI	Band 3 5470~5725MHz Harmonic @ 3m	
ANT	802.11ac VHT20 CH100 5500MHz	
1+2	Horizontal	Vertical
Peak Avg.	<p>Site : 03CH07-HY Condition : FCC PART 15E_BAND4 3m HF-ANT_130829 HORIZONTAL Detector : Peak Project : 640145-06 Mode : 1</p>	<p>Site : 03CH07-HY Condition : FCC PART 15E_BAND4 3m HF-ANT_130829 VERTICAL Detector : Peak Project : 640145-06 Mode : 1</p>



Emission below 1GHz
5GHz WIFI 802.11ac VHT20 (LF)

<PMA Charging Mode>

Table with 4 columns: WIFI, ANT, 1+2, and two columns for Horizontal and Vertical plots. The plots show Level (dBuV/m) vs Frequency (MHz) with FCC CLASS B limits. Includes metadata like Site, Condition, Detector, Project, and Mode.



Emission below 1GHz
5GHz WIFI 802.11ac VHT20 (LF)

<WPC Charging Mode>

WIFI	5GHz WIFI	
ANT	802.11ac VHT20 LF	
1+2	Horizontal	Vertical
QP / Peak	<p>Site : 03CH074Y Condition : FCC CLASS B 3m LF-ANT-35419(6) HORIZONTAL Detector : Peak Project : 640145-06 Mode : 2</p>	<p>Site : 03CH074Y Condition : FCC CLASS B 3m LF-ANT-35419(6) VERTICAL Detector : Peak Project : 640145-06 Mode : 2</p>



Appendix C. Duty Cycle Plots

Antenna	Band	Duty Cycle(%)	T(us)	1/T(kHz)	VBW Setting
1+2	5GHz 802.11a for Ant 1	94.95	2070	0.483091787	1kHz
1+2	5GHz 802.11a for Ant 2	94.95	2070	0.483091787	1kHz
1+2	5GHz 802.11n HT20 for Ant 1	94.94	2065	0.484261501	1kHz
1+2	5GHz 802.11n HT20 for Ant 2	94.95	2070	0.483091787	1kHz
1+2	5GHz 802.11n HT40 for Ant 1	90.48	950	1.052631579	3kHz
1+2	5GHz 802.11n HT40 for Ant 2	89.62	950	1.052631579	3kHz
1+2	5GHz 802.11ac VHT20 for Ant 1	95.09	1935	0.516795866	1kHz
1+2	5GHz 802.11ac VHT20 for Ant 2	94.63	1940	0.515463918	1kHz
1+2	5GHz 802.11ac VHT40 for Ant 1	90.52	955	1.047120419	3kHz
1+2	5GHz 802.11ac VHT40 for Ant 2	94.48	950	1.052631579	3kHz
1+2	5GHz 802.11ac VHT80 for Ant 1	82.14	460	2.173913043	3kHz
1+2	5GHz 802.11ac VHT80 for Ant 2	82.14	460	2.173913043	3kHz

MIMO <Ant. 1+2(1)>

802.11a

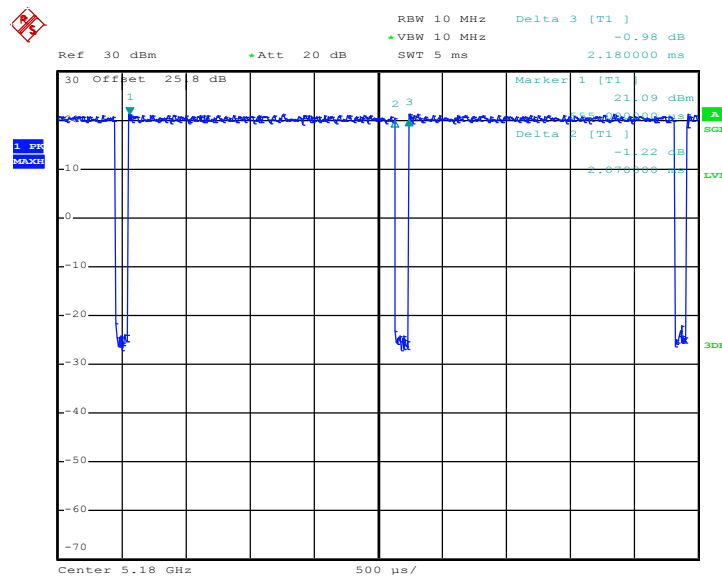



802.11n HT20

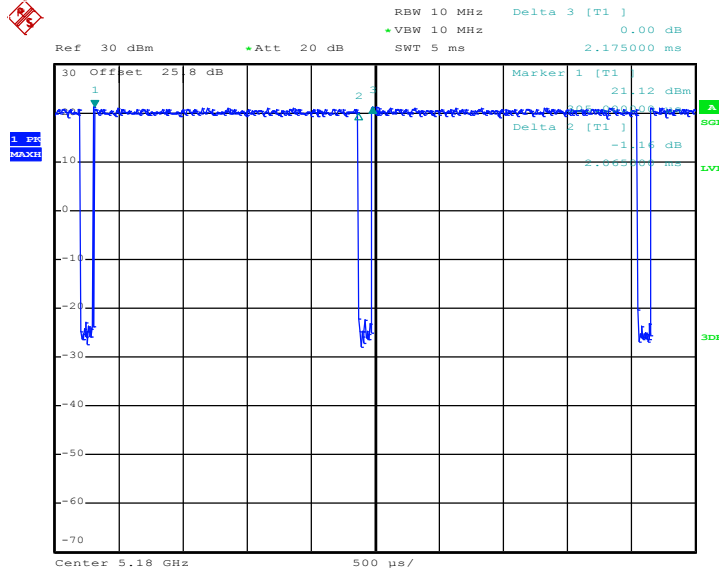

802.11n HT40

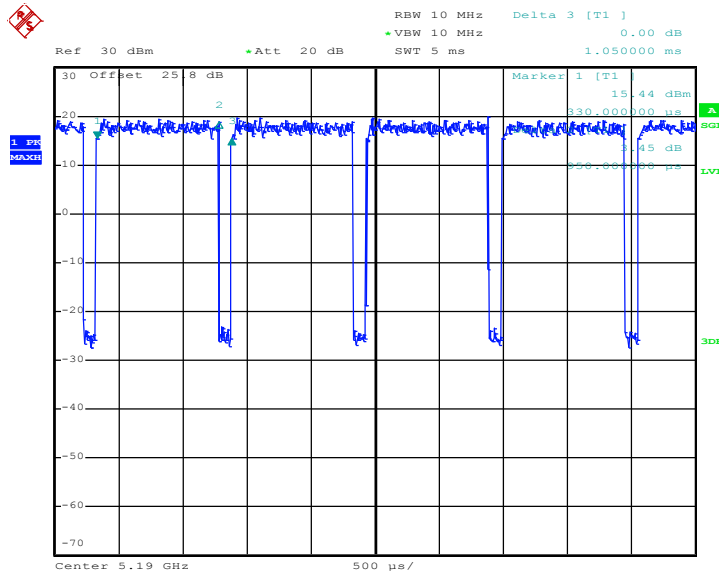



802.11ac VHT20

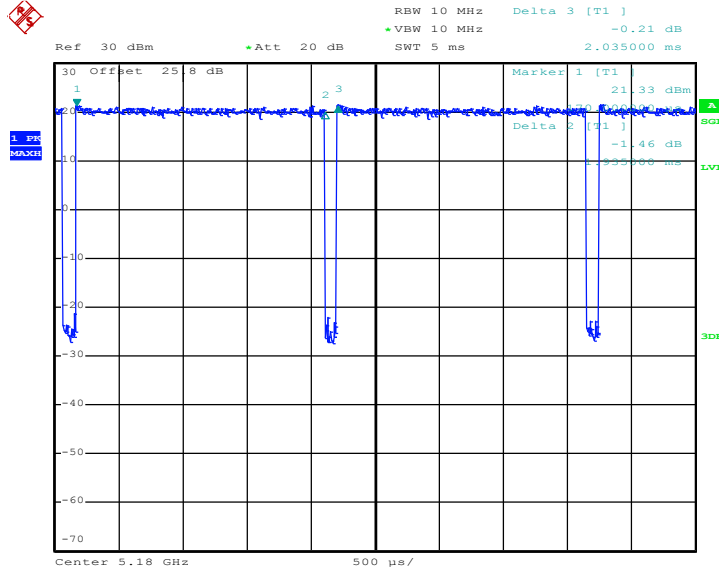

802.11ac VHT40

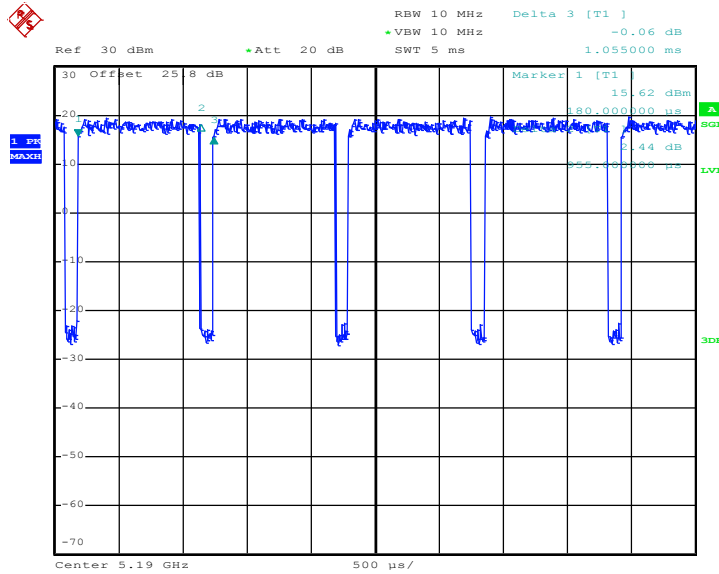



802.11ac VHT80

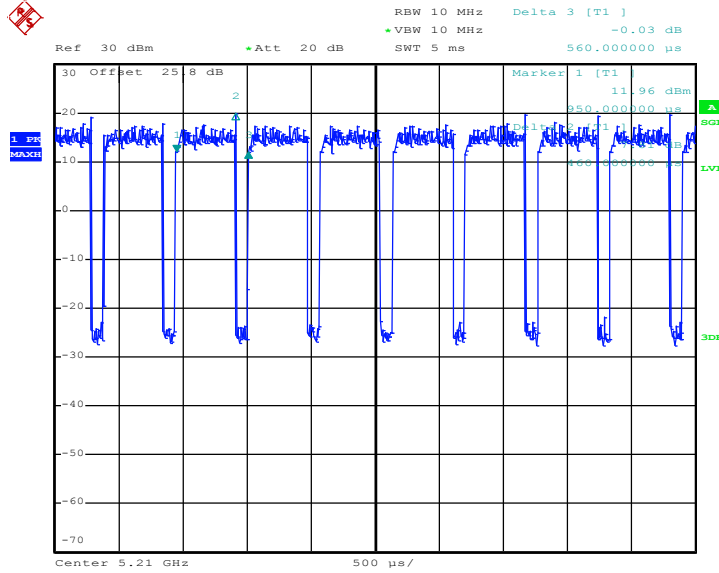



MIMO <Ant. 1+2(2)>

802.11a

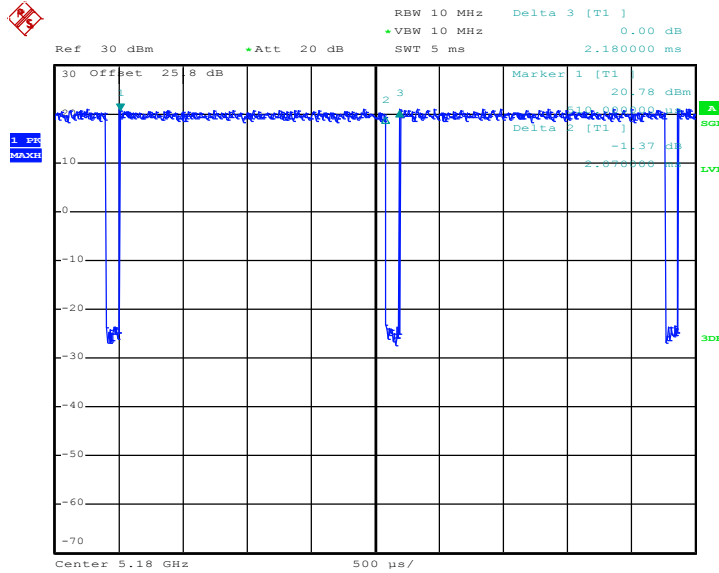

802.11n HT20

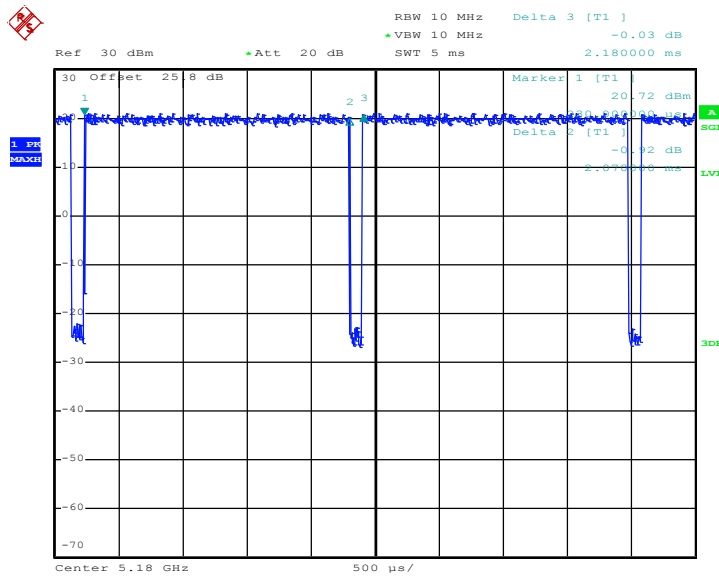



802.11n HT40

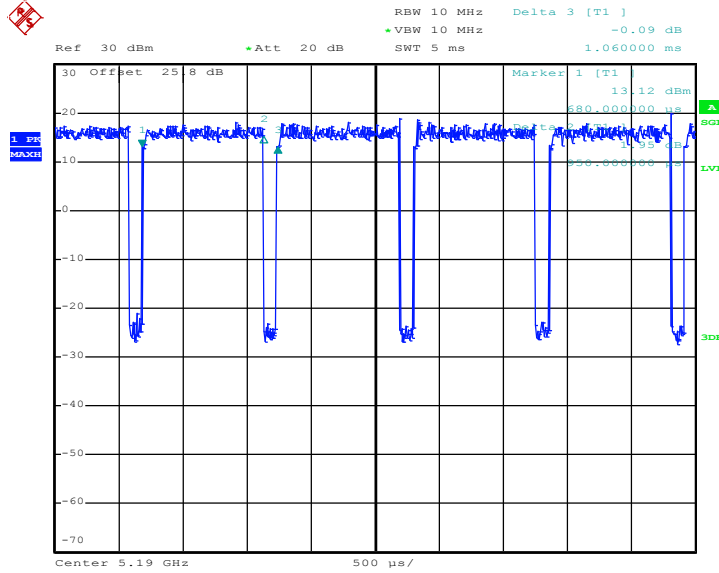

802.11ac VHT20

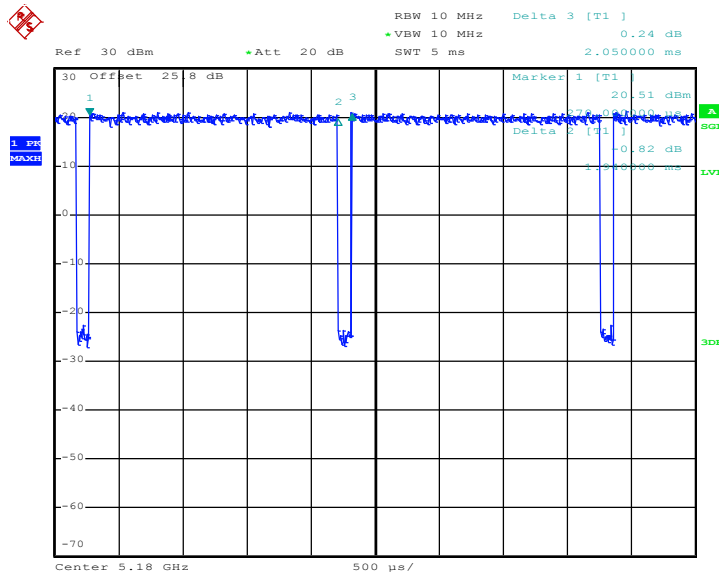



802.11ac VHT40

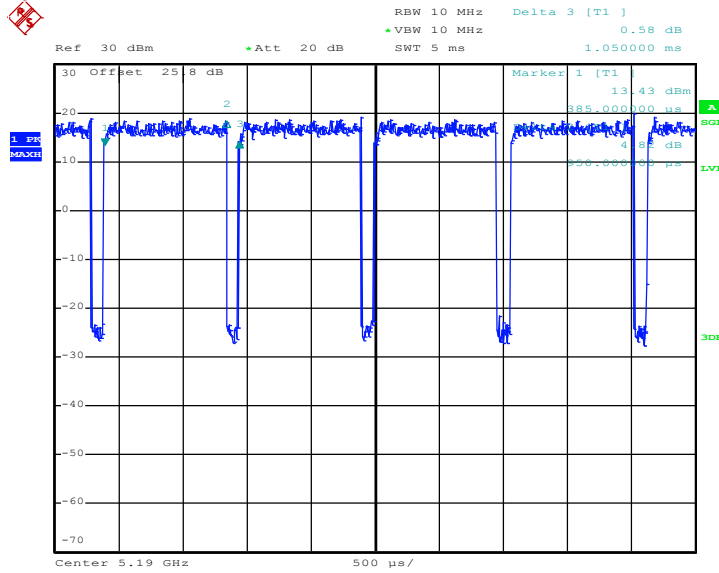

802.11ac VHT80

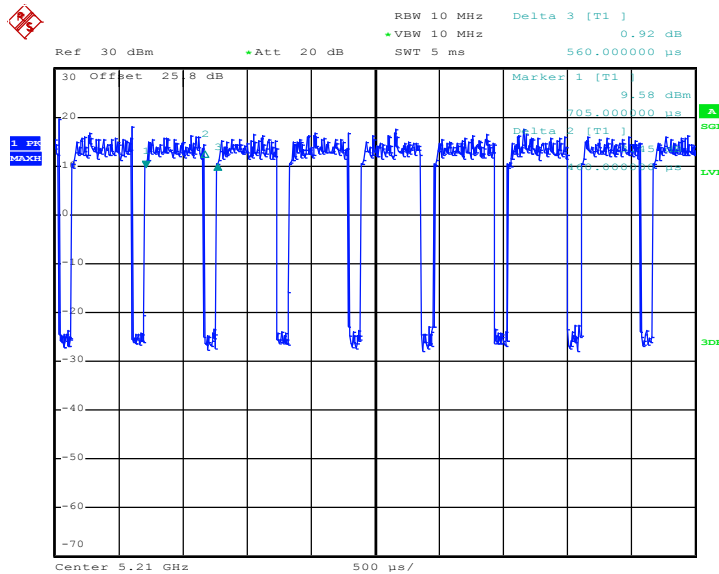



Appendix D. Original Report

Please refer to Sporton report number FR631828D as below.



FCC RF Test Report

APPLICANT : Motorola Mobility, LLC
EQUIPMENT : Mobile Cellular Phone
BRAND NAME : Motorola
MODEL NAME : 4237
FCC ID : IHDT56VB1
STANDARD : FCC Part 15 Subpart E §15.407
CLASSIFICATION : (NII) Unlicensed National Information Infrastructure

The product was received on Mar. 18, 2016 and testing was completed on Apr. 25, 2016. We, SPORTON INTERNATIONAL INC., would like to declare that the tested sample has been evaluated in accordance with the test procedures and has been in compliance with the applicable technical standards.

The test results in this report apply exclusively to the tested model / sample. Without written approval of SPORTON INTERNATIONAL INC., the test report shall not be reproduced except in full.

Reviewed by: Joseph Lin / Supervisor

Approved by: Jones Tsai / Manager



SPORTON INTERNATIONAL INC.

No. 52, Hwa Ya 1st Rd., Hwa Ya Technology Park, Kwei-Shan District, Tao Yuan City, Taiwan, R.O.C.

SPORTON INTERNATIONAL INC.

TEL : 886-3-327-3456

FAX : 886-3-328-4978

FCC ID : IHDT56VB1

Page Number : 1 of 43

Report Issued Date : May 10, 2016

Report Version : Rev. 01

Report Template No.: BU5-FR15EWLAC MA Version 1.4



TABLE OF CONTENTS

REVISION HISTORY..... 3

SUMMARY OF TEST RESULT 4

1 GENERAL DESCRIPTION 5

 1.1 Applicant 5

 1.2 Manufacturer..... 5

 1.3 Product Feature of Equipment Under Test..... 5

 1.4 Product Specification of Equipment Under Test..... 6

 1.5 Modification of EUT 7

 1.6 Testing Location 8

 1.7 Applicable Standards..... 8

2 TEST CONFIGURATION OF EQUIPMENT UNDER TEST 9

 2.1 Carrier Frequency and Channel 10

 2.2 Pre-Scanned RF Power..... 11

 2.3 Test Mode..... 17

 2.4 Connection Diagram of Test System..... 20

 2.5 Support Unit used in test configuration and system 21

 2.6 EUT Operation Test Setup 21

 2.7 Measurement Results Explanation Example..... 21

3 TEST RESULT..... 22

 3.1 26dB & 99% Occupied Bandwidth Measurement 22

 3.2 Maximum Conducted Output Power Measurement 24

 3.3 Power Spectral Density Measurement 27

 3.4 Unwanted Emissions Measurement..... 30

 3.5 AC Conducted Emission Measurement..... 34

 3.6 Frequency Stability Measurement..... 39

 3.7 Automatically Discontinue Transmission 40

 3.8 Antenna Requirements..... 41

4 LIST OF MEASURING EQUIPMENT 42

5 UNCERTAINTY OF EVALUATION 43

APPENDIX A. CONDUCTED TEST RESULTS

APPENDIX B. RADIATED SPURIOUS EMISSION

APPENDIX C. RADIATED SPURIOUS EMISSION PLOTS

APPENDIX D. DUTY CYCLE PLOTS



REVISION HISTORY

REPORT NO.	VERSION	DESCRIPTION	ISSUED DATE
FR631828D	Rev. 01	Initial issue of report	May 10, 2016



SUMMARY OF TEST RESULT

Report Section	FCC Rule	Description	Limit	Result	Remark
3.1	2.1049 15.403(i)	26dB & 99% Bandwidth	-	Pass	-
3.2	15.407(a)	Maximum Conducted Output Power	≤ 24 dBm (depend on band)	Pass	-
3.3	15.407(a)	Power Spectral Density	≤ 11 dBm (depend on band)	Pass	-
3.4	15.407(b)	Unwanted Emissions	≤ -17, -27 dBm (depend on band) &15.209(a)	Pass	Under limit 0.09 dB at 5468.08 MHz
3.5	15.207	AC Conducted Emission	15.207(a)	Pass	Under limit 21.80 dB at 0.726 MHz
3.6	15.407(g)	Frequency Stability	Within Operation Band	Pass	-
3.7	15.407(c)	Automatically Discontinue Transmission	Discontinue Transmission	Pass	-
3.8	15.203 & 15.407(a)	Antenna Requirement	N/A	Pass	-



1 General Description

1.1 Applicant

Motorola Mobility, LLC

222 W Merchandise Mart Plaza, Suite 1800, Chicago, IL 60654, United States

1.2 Manufacturer

Motorola Mobility, LLC

222 W Merchandise Mart Plaza, Suite 1800, Chicago, IL 60654, United States

1.3 Product Feature of Equipment Under Test

Product Feature	
Equipment	Mobile Cellular Phone
Brand Name	Motorola
Model Name	4237
IMEI Code	354107070048983 (for Radiation) 354107070048744 (for Conduction)
FCC ID	IHDT56VB1
EUT supports Radios application	CDMA/EV-DO/GSM/EGPRS/WCDMA/HSPA/LTE 2.4GHz WLAN 11b/g/n HT20 WLAN 11ac VHT20 5GHz WLAN 11a/n HT20/HT40 WLAN 11ac VHT20/VHT40/VHT80 Bluetooth v3.0 EDR Bluetooth v4.2 LE
HW Version	DVT2
EUT Stage	Identical Prototype

Remark: The above EUT's information was declared by manufacturer. Please refer to the specifications or user's manual for more detailed description.

Accessory List	
AC Adapter	Brand Name : Motorola
	Model Name : SPN5913A



1.4 Product Specification of Equipment Under Test

Standards-related Product Specification	
Tx/Rx Channel Frequency Range	5180 MHz ~ 5240 MHz 5260 MHz ~ 5320 MHz 5500 MHz ~ 5700 MHz
Maximum Output Power	<p><5180 MHz ~ 5240 MHz> SISO <Ant. 1> 802.11a : 16.30 dBm / 0.0427 W 802.11n HT20 : 16.17 dBm / 0.0414 W 802.11n HT40 : 14.25 dBm / 0.0266 W 802.11ac VHT20: 16.21 dBm / 0.0418 W 802.11ac VHT40: 14.56 dBm / 0.0286 W 802.11ac VHT80: 13.42 dBm / 0.0220 W SISO <Ant. 2> 802.11a : 15.79 dBm / 0.0379 W 802.11n HT20 : 15.52 dBm / 0.0356 W 802.11n HT40 : 14.00 dBm / 0.0251 W 802.11ac VHT20: 15.74 dBm / 0.0375 W 802.11ac VHT40: 13.97 dBm / 0.0249 W 802.11ac VHT80: 12.62 dBm / 0.0183 W MIMO <Ant. 1 + 2> 802.11a : 18.27 dBm / 0.0437 W 802.11n HT20 : 18.07 dBm / 0.0641 W 802.11n HT40 : 16.57 dBm / 0.0454 W 802.11ac VHT20: 18.23 dBm / 0.0665 W 802.11ac VHT40: 16.55 dBm / 0.0452 W 802.11ac VHT80: 15.55 dBm / 0.0359 W</p> <p><5260 MHz ~ 5320 MHz> SISO <Ant. 1> 802.11a : 16.40 dBm / 0.437 W 802.11n HT20 : 16.20 dBm / 0.0417 W 802.11n HT40 : 14.51 dBm / 0.0282 W 802.11ac VHT20: 16.14 dBm / 0.0411 W 802.11ac VHT40: 14.60 dBm / 0.0288 W 802.11ac VHT80: 12.53 dBm / 0.0179 W SISO <Ant. 2> 802.11a : 15.76 dBm / 0.0377 W 802.11n HT20 : 15.56 dBm / 0.0360 W 802.11n HT40 : 13.89 dBm / 0.0245 W 802.11ac VHT20: 15.71 dBm / 0.0372 W 802.11ac VHT40: 13.90 dBm / 0.0245 W 802.11ac VHT80: 11.70 dBm / 0.0148 W MIMO <Ant. 1 + 2> 802.11a : 18.37 dBm / 0.0687 W 802.11n HT20 : 18.03 dBm / 0.0635 W 802.11n HT40 : 16.60 dBm / 0.0457 W 802.11ac VHT20: 18.08 dBm / 0.0643 W 802.11ac VHT40: 16.53 dBm / 0.0450 W 802.11ac VHT80: 14.67 dBm / 0.0293 W</p>



Product Specification subjective to this standard										
Maximum Output Power	<p><5500 MHz ~ 5700 MHz></p> <p>SISO <Ant. 1> 802.11a : 16.70 dBm / 0.0468 W 802.11n HT20 : 16.54 dBm / 0.0451 W 802.11n HT40 : 14.60 dBm / 0.0288 W 802.11ac VHT20: 16.51 dBm / 0.0448 W 802.11ac VHT40: 14.60 dBm / 0.0288 W 802.11ac VHT80: 14.76 dBm / 0.0299 W</p> <p>SISO <Ant. 2> 802.11a : 16.10 dBm / 0.0407 W 802.11n HT20 : 16.23 dBm / 0.0420 W 802.11n HT40 : 14.32 dBm / 0.0270 W 802.11ac VHT20: 16.15 dBm / 0.0412 W 802.11ac VHT40: 14.23 dBm / 0.0265 W 802.11ac VHT80: 14.41 dBm / 0.0276 W</p> <p>MIMO <Ant. 1 + 2> 802.11a : 18.60 dBm / 0.0724 W 802.11n HT20 : 18.02 dBm / 0.0634 W 802.11n HT40 : 16.70 dBm / 0.0468 W 802.11ac VHT20: 18.52 dBm / 0.0711 W 802.11ac VHT40: 16.57 dBm / 0.0454 W 802.11ac VHT80: 16.89 dBm / 0.0489 W</p>									
99% Occupied Bandwidth	802.11a : 18.15 MHz 802.11n HT20 : 18.75 MHz 802.11n HT40 : 36.40 MHz 802.11ac VHT20 : 19.60 MHz 802.11ac VHT40 : 36.40 MHz 802.11ac VHT80 : 75.60 MHz									
Type of Modulation	802.11a/n : OFDM (BPSK / QPSK / 16QAM / 64QAM) 802.11ac : OFDM (BPSK / QPSK / 16QAM / 64QAM / 256QAM)									
Antenna Type	Fixed Internal Antenna type (The antenna peak gain of EUT is less than 6 dBi)									
Antenna Function Description	<table border="1"> <thead> <tr> <th></th> <th>Ant.1</th> <th>Ant.2</th> </tr> </thead> <tbody> <tr> <td>802.11 a/a/n/ac SISO</td> <td>V</td> <td>V</td> </tr> <tr> <td>802.11 a/n/ac MIMO</td> <td>V</td> <td>V</td> </tr> </tbody> </table>		Ant.1	Ant.2	802.11 a/a/n/ac SISO	V	V	802.11 a/n/ac MIMO	V	V
	Ant.1	Ant.2								
802.11 a/a/n/ac SISO	V	V								
802.11 a/n/ac MIMO	V	V								

1.5 Modification of EUT

No modifications are made to the EUT during all test items.



1.6 Testing Location

Sporton Lab is accredited to ISO 17025 by Taiwan Accreditation Foundation (TAF code : 1190) and the FCC designation No. TW1022 under the FCC 2.948(e) by Mutual Recognition Agreement (MRA) in FCC Test.

Test Site	SPORTON INTERNATIONAL INC.	
Test Site Location	No. 52, Hwa Ya 1 st Rd., Hwa Ya Technology Park, Kwei-Shan District, Tao Yuan City, Taiwan, R.O.C. TEL: +886-3-327-3456 FAX: +886-3-328-4978	
Test Site No.	Sporton Site No.	
	TH02-HY	CO05-HY

Note: The test site complies with ANSI C63.4 2014 requirement.

Test Site	SPORTON INTERNATIONAL INC.	
Test Site Location	No.58, Aly. 75, Ln. 564, Wenhua 3rd Rd. Guishan Dist, Taoyuan City, Taiwan (R.O.C.) TEL: +886-3-327-0868 FAX: +886-3-327-0855	
Test Site No.	Sporton Site No.	
	03CH11-HY	

Note: The test site complies with ANSI C63.4 2014 requirement.

1.7 Applicable Standards

According to the specifications of the manufacturer, the EUT must comply with the requirements of the following standards:

- ♦ FCC Part 15 Subpart E
- ♦ FCC KDB 789033 D02 General UNII Test Procedures New Rules v01r02
- ♦ FCC KDB 662911 D01 Multiple Transmitter Output v02r01.
- ♦ FCC KDB 644545 D03 Guidance for IEEE 802 11ac New Rules v01
- ♦ ANSI C63.10-2013

Remark:

1. All test items were verified and recorded according to the standards and without any deviation during the test.
2. This EUT has also been tested and complied with the requirements of FCC Part 15, Subpart B, recorded in a separate test report.



2 Test Configuration of Equipment Under Test

The EUT has been associated with peripherals and configuration operated in a manner tended to maximize its emission characteristics in a typical application. Frequency range investigated: conducted emission (150 kHz to 30 MHz) and radiated emission (9 kHz to the 10th harmonic of the highest fundamental frequency or to 40 GHz, whichever is lower). For radiated measurement, pre-scanned in three orthogonal panels, X, Y, Z. The worst cases (X plane) were recorded in this report.

The final configuration from all the combinations and the worst-case data rates were investigated by measuring the maximum power across all the data rates and modulation modes under section 2.2.

Based on the worst configuration found above, the RF power setting is set individually to meet FCC compliance limit for the final conducted and radiated tests shown in section 2.3.



2.1 Carrier Frequency and Channel

Frequency Band	Channel	Freq. (MHz)	Channel	Freq. (MHz)
5150-5250 MHz Band 1 (U-NII-1)	36	5180	44	5220
	38	5190	46	5230
	40	5200	48	5240
	42	5210		

Frequency Band	Channel	Freq. (MHz)	Channel	Freq. (MHz)
5250-5350 MHz Band 2 (U-NII-2A)	52	5260	60	5300
	54	5270	62	5310
	56	5280	64	5320
	58	5290		

Frequency Band	Channel	Freq. (MHz)	Channel	Freq. (MHz)
5470-5600 MHz and 5650-5725 MHz Band 3 (U-NII-2C)	100	5500	112	5560
	102	5510	116	5580
	104	5520	132	5660
	106	5530	134	5670
	108	5540	136	5680
	110	5550	140	5700

Frequency Band	Channel	Freq. (MHz)	Channel	Freq. (MHz)
Straddle Channel	144	5720	142	5710
	138	5690		

Note: The above Frequency and Channel in boldface were 802.11n HT40.



2.2 Pre-Scanned RF Power

Preliminary tests were performed in different data rate and data rate associated with the highest power were chosen for full test in the following tables.

SISO <Ant. 1>

Channel	Frequency	5GHz 802.11a Average Power (dBm)							
		Data Rate							
		6 Mbps	9 Mbps	12 Mbps	18 Mbps	24 Mbps	36 Mbps	48 Mbps	54 Mbps
CH 36	5180 MHz	16.30	16.16	16.21	16.25	16.02	14.97	14.65	13.73
CH 44	5220 MHz	16.23	16.20	16.18	16.23	15.95	14.95	14.61	13.68
CH 48	5240 MHz	16.26	16.16	16.15	16.24	15.96	14.94	14.66	13.65
CH 52	5260 MHz	16.40	16.39	16.31	16.38	16.18	15.09	14.86	13.86
CH 60	5300 MHz	16.07	16.06	16.01	16.04	15.98	15.14	14.97	13.88
CH 64	5320 MHz	16.04	16.02	16.02	16.00	16.01	15.09	14.81	13.78
CH 100	5500 MHz	16.70	16.69	16.68	16.65	16.40	15.41	15.14	13.68
CH 116	5580 MHz	16.67	16.65	16.64	16.66	16.59	15.42	15.01	14.15
CH 140	5700 MHz	15.68	15.64	15.60	15.67	15.43	14.49	13.91	12.76

Channel	Frequency	5GHz 802.11n HT20 Average Power (dBm)							
		Data Rate							
		MCS0	MCS1	MCS2	MCS3	MCS4	MCS5	MCS6	MCS7
CH 36	5180 MHz	16.17	15.91	15.98	15.36	15.45	14.49	13.88	12.93
CH 44	5220 MHz	15.98	15.63	15.78	15.10	15.24	14.30	13.70	12.69
CH 48	5240 MHz	16.09	15.73	16.02	15.32	15.41	14.54	13.98	12.96
CH 52	5260 MHz	16.20	15.77	16.00	15.34	15.51	14.60	13.90	12.98
CH 60	5300 MHz	16.00	15.66	15.83	15.12	15.25	14.28	13.82	12.71
CH 64	5320 MHz	15.86	15.73	15.82	15.04	15.32	14.42	13.88	12.75
CH 100	5500 MHz	16.54	16.50	16.49	16.31	16.38	14.69	14.03	13.05
CH 116	5580 MHz	16.50	16.38	16.45	16.19	16.34	14.63	14.01	13.00
CH 140	5700 MHz	15.77	15.64	15.74	15.00	15.26	14.34	13.78	12.64

Channel	Frequency	5GHz 802.11n HT40 Average Power (dBm)							
		Data Rate							
		MCS0	MCS1	MCS2	MCS3	MCS4	MCS5	MCS6	MCS7
CH 38	5190MHz	13.78	13.70	13.77	13.69	13.73	13.66	13.75	12.84
CH 46	5230MHz	14.25	14.19	14.21	13.64	13.78	13.61	13.62	12.92
CH 54	5270MHz	14.51	14.48	14.47	14.08	13.87	13.95	13.95	12.94
CH 62	5310MHz	13.82	13.66	13.64	13.58	13.61	13.56	13.65	12.66
CH 102	5510MHz	13.79	13.56	13.56	13.62	13.60	13.58	13.74	12.98
CH 110	5550MHz	14.34	14.29	14.32	13.71	13.83	13.65	13.65	12.98
CH 134	5670MHz	14.60	14.41	14.53	13.96	14.03	13.91	13.84	13.18



Channel	Frequency	5GHz 802.11ac VHT20 Average Power (dBm)								
		Data Rate								
		MCS0	MCS1	MCS2	MCS3	MCS4	MCS5	MCS6	MCS7	MCS8
CH 36	5180 MHz	16.21	16.03	16.01	14.80	14.74	13.67	13.07	12.21	10.09
CH 44	5220 MHz	16.07	15.98	15.98	14.67	14.77	13.82	12.77	11.90	8.61
CH 48	5240 MHz	16.18	16.02	15.96	14.87	14.88	13.95	13.12	12.08	7.80
CH 52	5260 MHz	16.14	15.83	15.94	14.84	14.67	13.80	13.02	12.11	8.30
CH 60	5300 MHz	16.03	15.77	15.87	14.72	14.61	13.75	12.27	11.69	8.67
CH 64	5320 MHz	15.98	15.72	15.75	14.64	14.54	13.73	12.21	11.42	8.57
CH 100	5500 MHz	16.51	16.35	16.24	15.22	15.13	14.38	13.02	12.01	9.31
CH 116	5580 MHz	16.46	16.31	16.17	15.18	15.06	14.30	13.28	12.48	9.84
CH 140	5700 MHz	15.68	15.59	15.38	14.37	14.30	13.45	12.29	11.39	8.95

Channel	Frequency	5GHz 802.11ac VHT40 Average Power (dBm)									
		Data Rate									
		MCS0	MCS1	MCS2	MCS3	MCS4	MCS5	MCS6	MCS7	MCS8	MCS9
CH 38	5190MHz	13.59	13.57	13.50	13.52	13.56	13.52	13.55	13.00	9.97	9.48
CH 46	5230MHz	14.56	14.48	14.54	13.47	13.71	13.76	13.66	12.72	8.45	7.91
CH 54	5270MHz	14.60	14.53	14.54	13.78	13.82	13.89	13.85	12.99	8.71	8.39
CH 62	5310MHz	13.93	13.89	13.91	13.22	13.37	13.54	13.30	12.33	8.31	7.85
CH 102	5510MHz	14.06	14.02	14.00	13.89	14.00	14.01	13.52	12.73	9.41	8.84
CH 110	5550MHz	14.39	14.32	14.36	13.52	13.67	13.59	13.09	12.26	8.89	8.68
CH 134	5670MHz	14.60	14.48	14.47	14.41	13.50	13.54	13.25	12.42	9.15	8.80

Channel	Frequency	5GHz 802.11ac VHT80 Average Power (dBm)									
		Data Rate									
		MCS0	MCS1	MCS2	MCS3	MCS4	MCS5	MCS6	MCS7	MCS8	MCS9
CH 042	5210MHz	13.42	13.36	13.40	13.32	13.38	13.36	12.75	11.80	8.43	6.54
CH 058	5290MHz	12.53	12.49	12.47	12.31	12.49	12.36	12.14	11.70	8.83	6.69
CH 106	5530MHz	8.54	8.49	8.53	8.51	8.49	8.47	8.52	8.52	8.51	6.80
CH 122	5610MHz	14.76	14.75	14.73	14.64	14.72	14.21	13.79	12.89	9.24	8.20



SISO <Ant. 2>

Channel	Frequency	5GHz 802.11a Average Power (dBm)							
		Data Rate							
		6 Mbps	9 Mbps	12 Mbps	18 Mbps	24 Mbps	36 Mbps	48 Mbps	54 Mbps
CH 36	5180 MHz	15.79	15.77	15.73	15.73	15.50	14.25	13.99	12.46
CH 44	5220 MHz	15.69	15.68	15.50	15.67	15.55	14.48	14.24	12.58
CH 48	5240 MHz	15.76	15.65	15.70	15.73	15.54	14.35	14.19	12.68
CH 52	5260 MHz	15.76	15.74	15.59	15.75	15.57	14.45	14.19	12.82
CH 60	5300 MHz	15.54	15.51	15.47	15.53	15.43	14.54	14.14	12.72
CH 64	5320 MHz	15.43	15.40	15.38	15.41	15.41	14.47	14.12	12.75
CH 100	5500 MHz	16.10	16.09	15.42	15.59	15.44	14.54	14.14	12.78
CH 116	5580 MHz	16.08	16.05	15.40	15.61	15.47	14.57	14.12	12.80
CH 140	5700 MHz	15.66	15.64	15.34	15.28	15.03	14.31	13.96	12.51

Channel	Frequency	5GHz 802.11n HT20 Average Power (dBm)							
		Data Rate							
		MCS0	MCS1	MCS2	MCS3	MCS4	MCS5	MCS6	MCS7
CH 36	5180 MHz	15.52	15.30	15.42	15.06	15.14	14.42	12.05	11.20
CH 44	5220 MHz	15.40	15.17	15.21	14.84	15.05	14.32	11.86	10.97
CH 48	5240 MHz	15.46	15.27	15.38	15.00	15.15	14.38	12.08	11.07
CH 52	5260 MHz	15.56	15.32	15.42	15.10	15.29	14.48	12.25	11.40
CH 60	5300 MHz	15.45	15.28	15.38	15.00	15.12	14.36	11.95	11.08
CH 64	5320 MHz	15.42	15.11	15.30	14.79	15.00	14.16	11.97	11.07
CH 100	5500 MHz	16.23	15.93	16.05	15.56	15.67	14.83	12.69	11.68
CH 116	5580 MHz	16.19	15.84	16.06	15.39	15.64	14.86	12.58	11.62
CH 140	5700 MHz	15.72	15.38	15.45	15.15	15.36	14.51	12.48	11.51

Channel	Frequency	5GHz 802.11n HT40 Average Power (dBm)							
		Data Rate							
		MCS0	MCS1	MCS2	MCS3	MCS4	MCS5	MCS6	MCS7
CH 38	5190MHz	13.43	13.41	13.38	13.22	13.11	13.26	12.80	11.78
CH 46	5230MHz	14.00	13.97	13.93	13.31	13.40	13.46	13.02	12.02
CH 54	5270MHz	13.89	13.86	13.84	12.98	13.19	13.33	12.80	11.92
CH 62	5310MHz	13.20	13.16	13.19	12.85	12.72	13.16	12.76	11.72
CH 102	5510MHz	13.26	13.25	13.24	13.22	13.24	13.25	13.12	12.00
CH 110	5550MHz	14.32	14.29	14.21	13.37	13.30	13.69	13.08	12.08
CH 134	5670MHz	14.19	14.14	14.18	13.21	13.25	13.32	13.00	11.90



Channel	Frequency	5GHz 802.11ac VHT20 Average Power (dBm)								
		Data Rate								
		MCS0	MCS1	MCS2	MCS3	MCS4	MCS5	MCS6	MCS7	MCS8
CH 36	5180 MHz	15.74	15.55	15.53	14.40	14.31	13.52	11.84	10.97	9.25
CH 44	5220 MHz	15.72	15.57	15.50	14.41	14.26	13.45	11.97	10.98	9.07
CH 48	5240 MHz	15.69	15.50	15.48	14.35	14.14	13.61	12.03	11.04	9.05
CH 52	5260 MHz	15.71	15.61	15.52	14.43	14.49	13.51	11.94	10.91	8.28
CH 60	5300 MHz	15.56	15.50	15.34	14.31	14.29	13.30	11.87	10.88	8.50
CH 64	5320 MHz	15.39	15.36	15.18	14.15	14.03	13.02	11.56	10.61	8.22
CH 100	5500 MHz	16.15	15.83	15.75	14.60	14.59	13.58	12.11	11.17	9.01
CH 116	5580 MHz	16.12	15.97	15.82	14.67	14.68	13.54	12.22	11.36	9.25
CH 140	5700 MHz	15.70	15.67	15.60	14.54	14.63	13.41	12.02	11.09	8.74

Channel	Frequency	5GHz 802.11ac VHT40 Average Power (dBm)									
		Data Rate									
		MCS0	MCS1	MCS2	MCS3	MCS4	MCS5	MCS6	MCS7	MCS8	MCS9
CH 38	5190MHz	13.03	12.97	12.94	12.81	13.00	12.97	12.59	11.57	9.18	8.72
CH 46	5230MHz	13.97	13.90	13.93	13.10	13.22	13.20	12.73	11.91	12.10	8.58
CH 54	5270MHz	13.90	13.87	13.83	12.91	13.00	13.04	12.60	11.70	8.28	7.47
CH 62	5310MHz	13.31	13.27	13.07	12.64	12.97	12.85	12.55	11.49	8.05	7.64
CH 102	5510MHz	13.42	13.38	13.34	13.23	13.37	13.31	12.80	11.91	8.77	8.48
CH 110	5550MHz	14.22	14.19	14.03	12.89	13.22	13.19	12.95	11.68	8.86	8.40
CH 134	5670MHz	14.23	14.21	14.06	12.93	13.27	13.25	13.01	11.76	8.50	7.91

Channel	Frequency	5GHz 802.11ac VHT80 Average Power (dBm)									
		Data Rate									
		MCS0	MCS1	MCS2	MCS3	MCS4	MCS5	MCS6	MCS7	MCS8	MCS9
CH 042	5210MHz	12.62	12.57	12.60	12.56	12.58	12.58	11.81	10.94	8.47	6.48
CH 058	5290MHz	11.70	11.67	11.63	11.60	11.68	11.66	11.41	11.07	8.12	6.23
CH 106	5530MHz	8.48	8.42	8.44	8.00	8.15	8.15	8.19	8.22	8.31	6.28
CH 122	5610MHz	14.41	14.39	14.39	14.37	14.26	13.92	13.02	12.21	8.63	7.55



MIMO <Ant. 1+2>

Channel	Frequency	5GHz 802.11a Average Power (dBm)							
		Data Rate							
		6 Mbps	9 Mbps	12 Mbps	18 Mbps	24 Mbps	36 Mbps	48 Mbps	54 Mbps
CH 36	5180 MHz	18.27	18.23	18.16	18.19	17.81	16.93	16.77	16.84
CH 44	5220 MHz	18.21	18.14	18.08	18.11	17.75	16.86	16.70	16.77
CH 48	5240 MHz	18.18	18.11	18.06	18.08	17.72	18.00	16.71	16.73
CH 52	5260 MHz	18.37	18.19	18.17	18.17	17.76	16.86	16.72	16.77
CH 60	5300 MHz	18.06	17.99	17.97	17.99	17.64	16.72	16.59	16.64
CH 64	5320 MHz	18.05	17.96	17.95	17.96	17.57	16.70	16.55	16.66
CH 100	5500 MHz	18.60	18.47	18.43	18.36	18.02	17.13	16.96	17.02
CH 116	5580 MHz	18.56	18.37	18.33	18.36	17.94	17.04	16.86	16.91
CH 140	5700 MHz	17.90	17.79	17.78	17.71	17.41	17.45	16.43	16.32

Channel	Frequency	5GHz 802.11n HT20 Average Power (dBm)							
		Data Rate							
		MCS0	MCS1	MCS2	MCS3	MCS4	MCS5	MCS6	MCS7
CH 36	5180 MHz	18.07	18.06	18.05	17.26	17.20	16.45	15.84	15.00
CH 44	5220 MHz	18.00	17.95	17.89	17.24	17.14	16.36	15.76	14.90
CH 48	5240 MHz	18.02	17.94	17.82	17.28	17.13	16.36	15.80	14.86
CH 52	5260 MHz	18.03	17.94	17.93	17.24	17.01	16.35	15.79	14.77
CH 60	5300 MHz	17.85	17.74	17.73	17.08	16.82	16.24	15.63	14.57
CH 64	5320 MHz	17.85	17.81	17.68	17.13	16.99	16.26	15.76	14.95
CH 100	5500 MHz	18.02	17.93	17.81	17.22	17.11	16.45	15.90	15.07
CH 116	5580 MHz	17.97	17.83	17.79	17.25	17.14	16.38	15.91	15.10
CH 140	5700 MHz	17.60	17.50	17.48	16.89	16.83	16.16	15.53	14.58

Channel	Frequency	5GHz 802.11n HT40 Average Power (dBm)							
		Data Rate							
		MCS0	MCS1	MCS2	MCS3	MCS4	MCS5	MCS6	MCS7
CH 38	5190MHz	16.05	16.00	16.03	15.74	15.89	16.03	15.93	15.21
CH 46	5230MHz	16.57	16.55	16.51	15.79	16.02	16.12	16.17	15.26
CH 54	5270MHz	16.60	16.58	16.55	15.73	15.96	16.16	16.03	15.23
CH 62	5310MHz	15.95	15.91	15.92	15.73	15.88	15.90	15.79	15.01
CH 102	5510MHz	16.11	16.06	16.02	16.01	16.06	16.06	15.96	15.43
CH 110	5550MHz	16.70	16.61	16.67	15.83	16.09	16.11	15.86	15.05
CH 134	5670MHz	16.51	16.47	16.49	15.69	15.87	16.02	15.84	15.11



Channel	Frequency	5GHz 802.11ac VHT20 Average Power (dBm)								
		Data Rate								
		MCS0	MCS1	MCS2	MCS3	MCS4	MCS5	MCS6	MCS7	MCS8
CH 36	5180 MHz	18.23	18.11	18.03	17.00	16.91	16.14	15.32	14.32	13.00
CH 44	5220 MHz	18.16	18.08	18.01	17.06	16.89	16.23	15.22	14.20	12.06
CH 48	5240 MHz	18.16	18.08	17.98	17.14	16.91	16.24	15.38	14.32	11.79
CH 52	5260 MHz	18.08	17.99	17.97	17.09	17.05	16.15	15.27	14.32	11.40
CH 60	5300 MHz	17.87	17.81	17.82	17.09	16.95	16.04	15.09	14.37	11.66
CH 64	5320 MHz	17.79	17.69	17.75	16.98	16.89	15.74	14.93	14.39	11.42
CH 100	5500 MHz	18.52	18.48	18.33	17.41	17.29	16.59	15.43	15.35	12.32
CH 116	5580 MHz	18.47	18.36	18.35	17.43	17.33	16.62	15.69	14.73	12.60
CH 140	5700 MHz	17.48	17.44	17.40	16.99	17.11	16.61	15.43	14.54	12.33

Channel	Frequency	5GHz 802.11ac VHT40 Average Power (dBm)									
		Data Rate									
		MCS0	MCS1	MCS2	MCS3	MCS4	MCS5	MCS6	MCS7	MCS8	MCS9
CH 38	5190MHz	15.67	15.51	15.60	15.61	15.63	15.66	15.52	15.13	12.54	12.14
CH 46	5230MHz	16.55	16.49	16.51	15.61	15.65	15.80	15.89	15.16	11.61	11.23
CH 54	5270MHz	16.53	16.49	16.50	15.85	15.78	15.95	15.89	15.08	11.31	10.90
CH 62	5310MHz	15.85	15.82	15.83	15.36	15.60	15.78	15.73	14.86	11.31	10.77
CH 102	5510MHz	16.03	16.01	15.99	16.01	16.00	16.00	15.91	15.22	12.00	11.79
CH 110	5550MHz	16.56	16.48	16.54	15.78	15.79	15.87	15.73	14.91	11.80	11.23
CH 134	5670MHz	16.57	16.55	16.51	15.60	15.65	15.87	15.74	14.93	11.80	11.40

Channel	Frequency	5GHz 802.11ac VHT80 Average Power (dBm)									
		Data Rate									
		MCS0	MCS1	MCS2	MCS3	MCS4	MCS5	MCS6	MCS7	MCS8	MCS9
CH 042	5210MHz	15.55	15.51	15.54	15.52	15.53	15.52	15.26	14.37	11.51	9.93
CH 058	5290MHz	14.67	14.61	14.63	14.59	14.65	14.63	14.63	14.46	11.47	9.62
CH 106	5530MHz	11.51	11.48	11.46	11.33	11.44	11.48	11.46	11.45	11.48	9.85
CH 122	5610MHz	16.89	16.80	16.74	16.82	16.84	15.71	15.91	15.00	11.44	10.55

Note: MIMO Ant. 1+2 is a calculated result from sum of the power MIMO Ant. 1 and MIMO Ant. 2.



2.3 Test Mode

Final test mode of conducted test items and radiated spurious emissions are considering the modulation and worse data rates from the power table described in section 2.2.

Single Antenna

Modulation	Data Rate
802.11a	6 Mbps
802.11n HT20	MCS0
802.11n HT40	MCS0
802.11ac VHT20	MCS0
802.11ac VHT40	MCS0
802.11ac VHT80	MCS0

MIMO Antenna

Modulation	Data Rate
802.11a	6 Mbps
802.11n HT20	MCS0
802.11n HT40	MCS0
802.11ac VHT20	MCS0
802.11ac VHT40	MCS0
802.11ac VHT80	MCS0

Test Cases	
AC Conducted Emission	Mode 1 : GSM850 Idle + Bluetooth Link + WLAN (5GHz) Link + Adapter + MP3



Ch. #		Band I : 5150-5250 MHz	Band II : 5250-5350 MHz	Band III : 5470-5600 MHz and 5650-5725MHz
		802.11a	802.11a	802.11a
L	Low	36	52	100
M	Middle	44	60	116
H	High	48	64	140
Straddle		-	-	144

Ch. #		Band I : 5150-5250 MHz	Band II : 5250-5350 MHz	Band III : 5470-5600 MHz and 5650-5725MHz
		802.11n HT20	802.11n HT20	802.11n HT20
L	Low	36	52	100
M	Middle	44	60	116
H	High	48	64	140
Straddle		-	-	144

Ch. #		Band I : 5150-5250 MHz	Band II : 5250-5350 MHz	Band III : 5470-5600 MHz and 5650-5725MHz
		802.11n HT40	802.11n HT40	802.11n HT40
L	Low	38	54	102
M	Middle	-	-	110
H	High	46	62	134
Straddle		-	-	142

Ch. #		Band I : 5150-5250 MHz	Band II : 5250-5350 MHz	Band III : 5470-5600 MHz and 5650-5725MHz
		802.11ac VHT20	802.11ac VHT20	802.11ac VHT20
L	Low	36	52	100
M	Middle	44	60	116
H	High	48	64	140
Straddle		-	-	144



Ch. #		Band I : 5150-5250 MHz	Band II : 5250-5350 MHz	Band III : 5470-5600 MHz and 5650-5725MHz
		802.11ac VHT40	802.11ac VHT40	802.11ac VHT40
L	Low	38	54	102
M	Middle	-	-	110
H	High	46	62	134
Straddle		-	-	142

Ch. #		Band I : 5150-5250 MHz	Band II : 5250-5350 MHz	Band III : 5470-5600 MHz and 5650-5725MHz
		802.11ac VHT80	802.11ac VHT80	802.11ac VHT80
L	Low	-	-	-
M	Middle	42	58	106
H	High	-	-	-
Straddle		-	-	138

2.4 Connection Diagram of Test System

<WLAN Tx Mode>

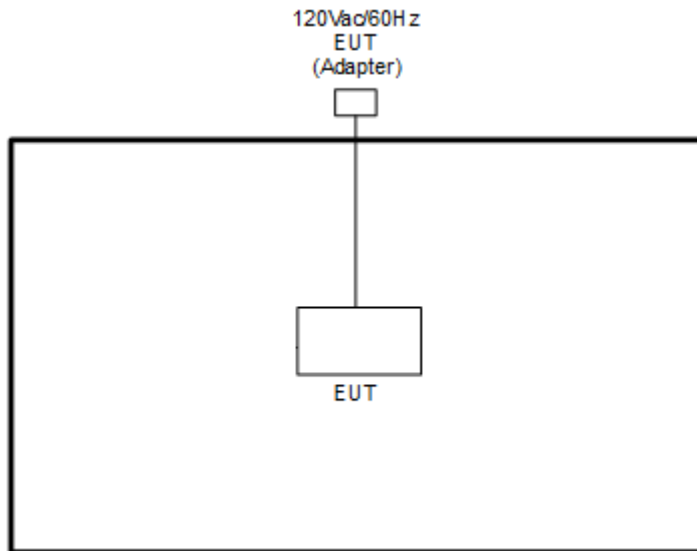

<AC Conducted Emission Mode>

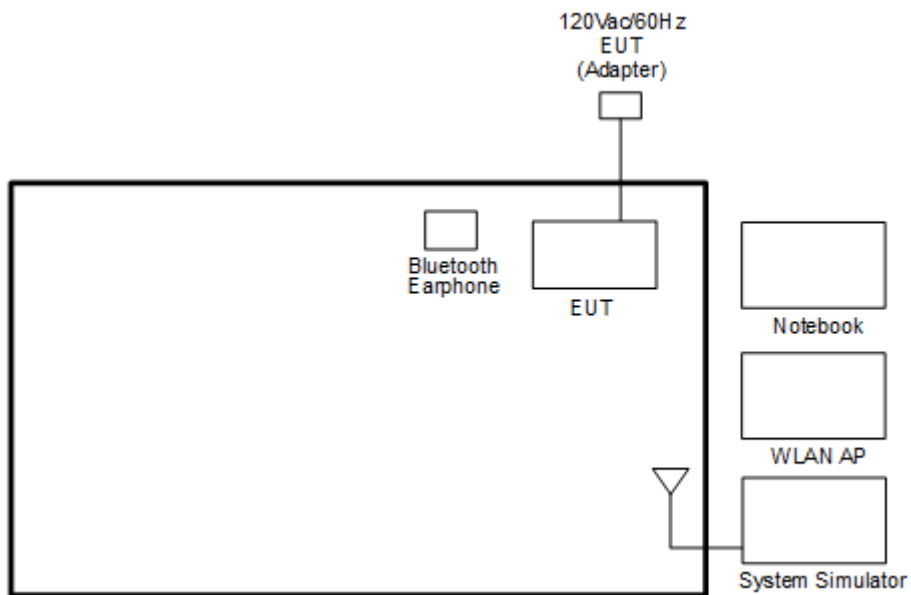



2.5 Support Unit used in test configuration and system

Item	Equipment	Trade Name	Model Name	FCC ID	Data Cable	Power Cord
1.	System Simulator	Anritsu	MT8820C	N/A	N/A	Unshielded, 1.8 m
2.	Bluetooth Earphone	Sony Ericsson	MW600	PY7DDA-2029	N/A	N/A
3.	Notebook	DELL	Latitude E6320	FCC DoC/ Contains FCC ID: QDS-BRCM1054	N/A	AC I/P: Unshielded, 1.2 m DC O/P: Shielded, 1.8 m
4.	SD Card	SanDisk	MicroSD HC	FCC DoC	N/A	N/A

2.6 EUT Operation Test Setup

For WLAN function, programmed RF utility, “QRCT” installed in the notebook make the EUT provide functions like channel selection and power level for continuous transmitting and receiving signals.

2.7 Measurement Results Explanation Example

For all conducted test items:

The offset level is set in the spectrum analyzer to compensate the RF cable loss and attenuator factor between EUT conducted output port and spectrum analyzer. With the offset compensation, the spectrum analyzer reading level is exactly the EUT RF output level.

Example :

The spectrum analyzer offset is derived from RF cable loss and attenuator factor.

Offset = RF cable loss + attenuator factor.

Following shows an offset computation example with cable loss 4.2 dB and 10dB attenuator.

$$\begin{aligned} \text{Offset(dB)} &= \text{RF cable loss(dB)} + \text{attenuator factor(dB)}. \\ &= 4.2 + 10 = 14.2 \text{ (dB)} \end{aligned}$$

3 Test Result

3.1 26dB & 99% Occupied Bandwidth Measurement

3.1.1 Description of 26dB & 99% Occupied Bandwidth

This section is for reporting purpose only.

There is no restriction limits for bandwidth.

For Straddle Channel, U-NII procedures were applied for operations in the frequency band in accordance with FCC KDB 644545 D03.

3.1.2 Measuring Instruments

The measuring equipment is listed in the section 4 of this test report.

3.1.3 Test Procedures

1. The testing follows FCC KDB 789033 D02 General UNII Test Procedures New Rules v01r02. Section C) Emission bandwidth
2. Set RBW = approximately 1% of the emission bandwidth.
3. Set the VBW > RBW.
4. Detector = Peak.
5. Trace mode = max hold
6. Measure the maximum width of the emission that is 26 dB down from the peak of the emission. Compare this with the RBW setting of the analyzer. Readjust RBW and repeat measurement as needed until the RBW/EBW ratio is approximately 1%.
7. For 99% Bandwidth Measurement, the spectrum analyzer's resolution bandwidth (RBW) is set 1MHz and set the Video bandwidth (VBW) $\geq 3 * RBW$.
8. Measure and record the results in the test report.

3.1.4 Test Setup

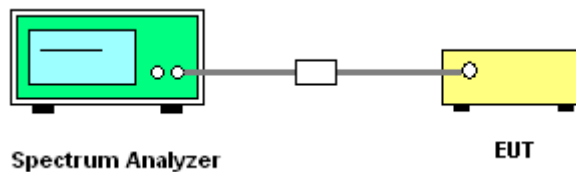



3.1.5 Test Result of 26dB & 99% Occupied Bandwidth

Please refer to Appendix A.

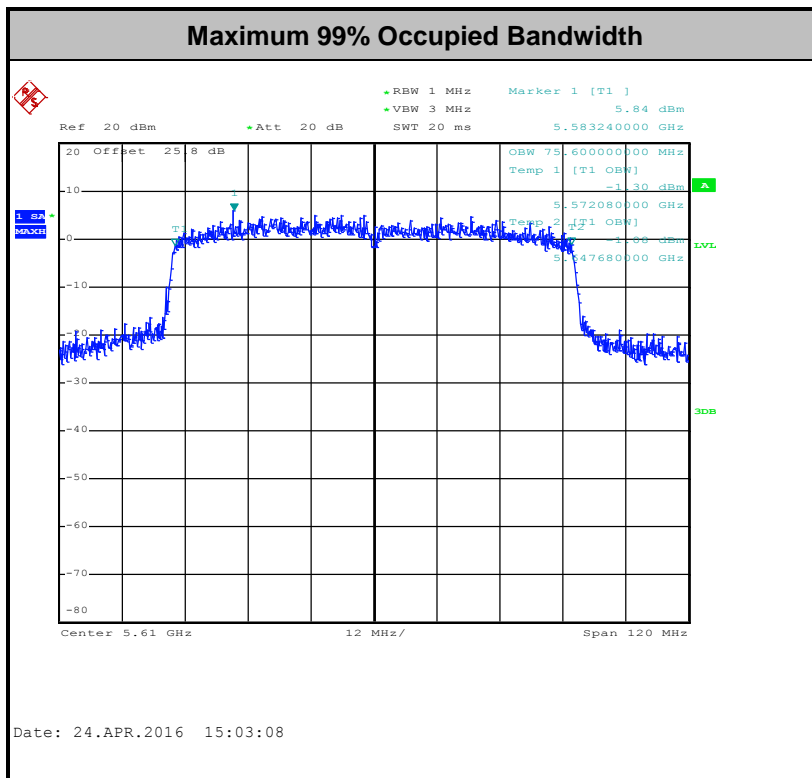
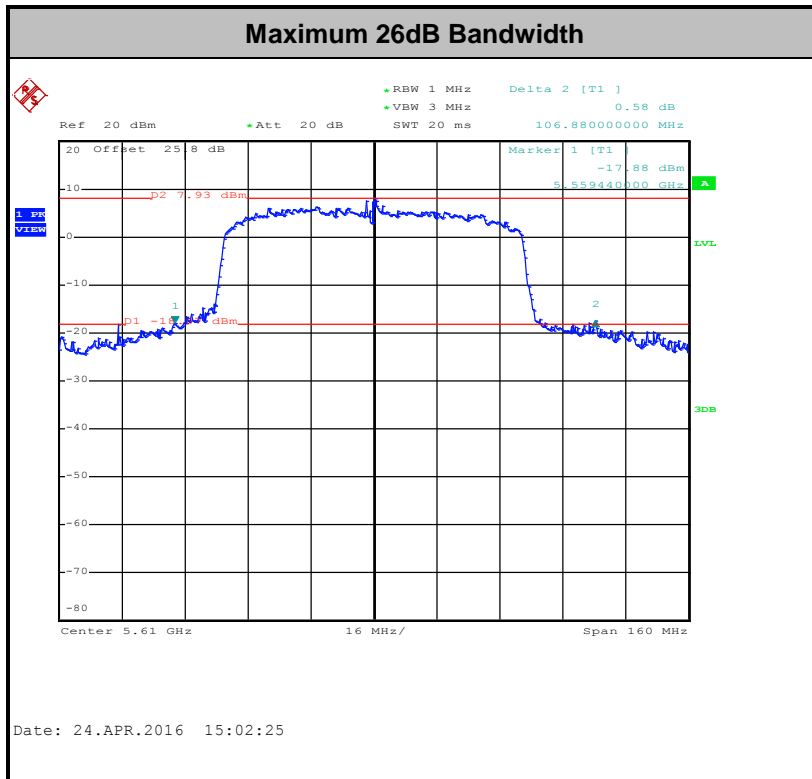

Note: The occupied channel bandwidth is maintained within the band of operation for all of the modulations.



3.2 Maximum Conducted Output Power Measurement

3.2.1 Limit of Maximum Conducted Output Power

For mobile and portable client devices in the 5.15–5.25 GHz band, the maximum conducted output power over the frequency band of operation shall not exceed 250 mW.

For the 5.25–5.35 GHz and 5.47–5.725 GHz bands, the maximum conducted output power over the frequency bands of operation shall not exceed the lesser of 250 mW or 11 dBm 10 log B, where B is the 26 dB emission bandwidth in megahertz.

For Straddle Channel, U-NII procedures and limits were applied for operations in the frequency band in accordance with FCC KDB 644545 D03.

If transmitting antennas of directional gain greater than 6 dBi are used, the peak output power shall be reduced by the amount in dB that the directional gain of the antenna exceeds 6 dBi.

Note that U-NII-2 band, devices with a maximum e.i.r.p. greater than 500 mW shall implement TPC in order to have the capability to operate at least 6 dB below the maximum permitted e.i.r.p. of 1 W.

3.2.2 Measuring Instruments

The measuring equipment is listed in the section 4 of this test report.

3.2.3 Test Procedures

The testing follows Method PM of FCC KDB 789033 D02 General UNII Test Procedures New Rules v01r02.

Method PM (Measurement using an RF average power meter):

1. Measurement is performed using a wideband RF power meter.
2. The EUT is configured to transmit continuously with a consistent duty cycle at its maximum power control level.
3. Measure the average power of the transmitter, and the average power is corrected with duty factor, $10 \log(1/x)$, where x is the duty cycle.

For straddle channel, the testing follows Method SA-3 (RMS detection with max hold) of FCC KDB 789033 D02 General UNII Test Procedures New Rules v01r02.

Compute power by integrating the spectrum across the 99% occupied bandwidth of the signal using the instrument's band power measurement function.

3.2.4 Test Setup

For normal channel:

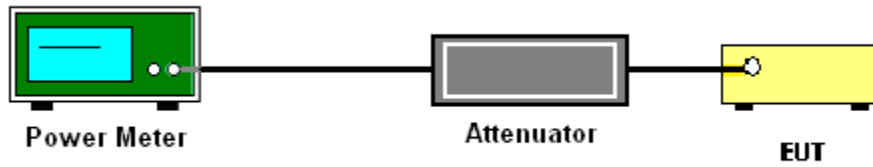

For straddle channel:

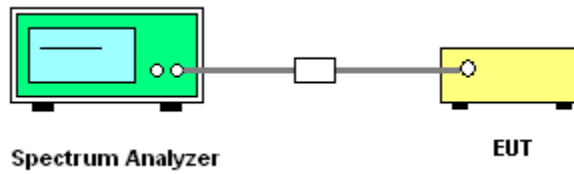

3.2.5 Test Result of Maximum Conducted Output Power

Please refer to Appendix A.



Maximum Straddle Channel Power

MIMO Ant. 1

NII-2C Band

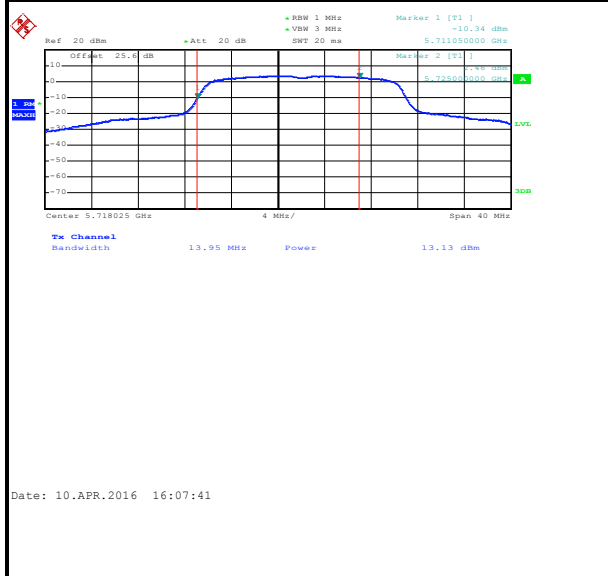

DTS Band

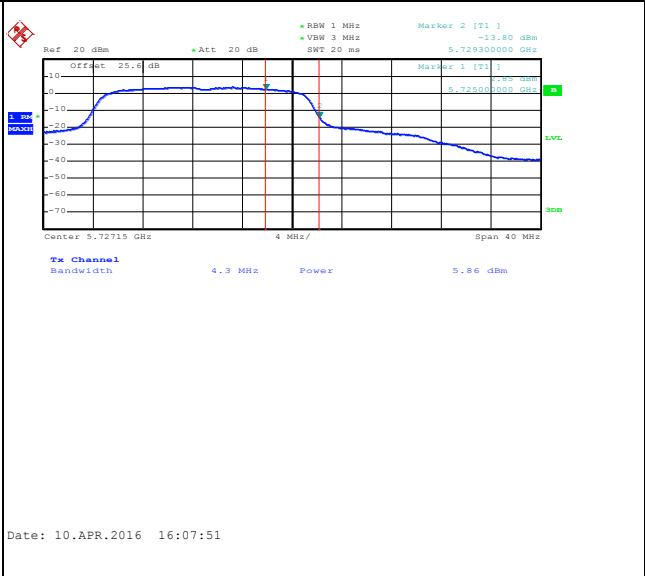

MIMO Ant. 2

NII-2C Band

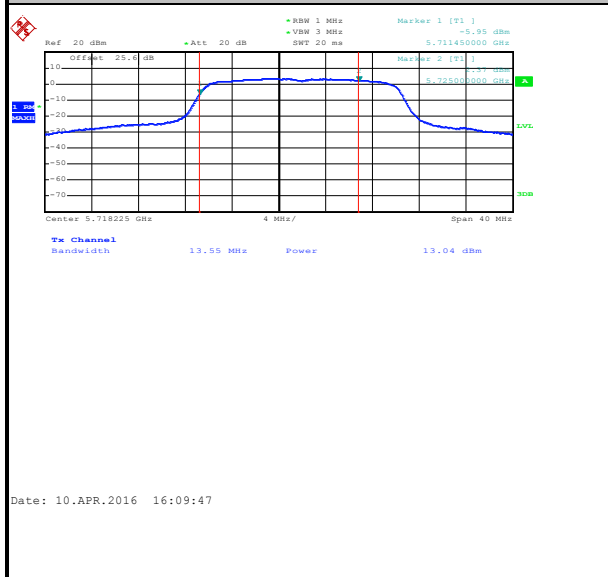

DTS Band

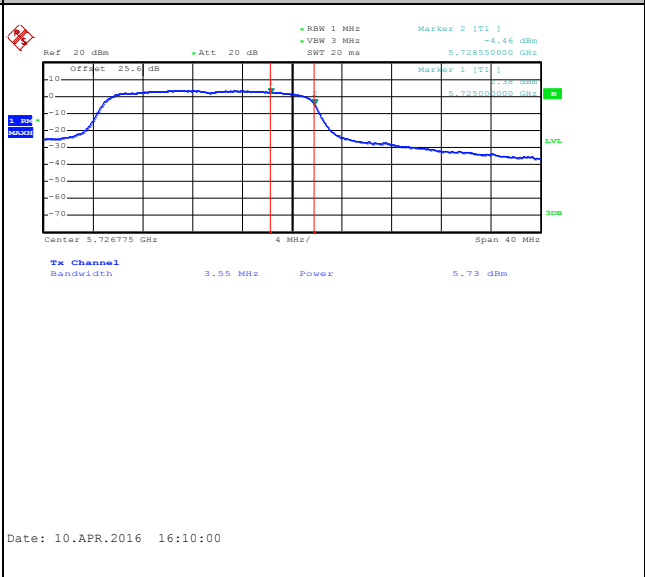



3.3 Power Spectral Density Measurement

3.3.1 Limit of Power Spectral Density

For mobile and portable client devices in the 5.15–5.25 GHz band, the maximum power spectral density shall not exceed 11dBm in any 1 megahertz band.

For the 5.25–5.35 GHz and 5.47–5.725 GHz bands, the maximum power spectral density shall not exceed 11 dBm in any 1 megahertz band.

For Straddle Channel, U-NII procedures and limits were applied for operations in the frequency band in accordance with FCC KDB 644545 D03.

If transmitting antennas of directional gain greater than 6 dBi are used, the peak output power shall be reduced by the amount in dB that the directional gain of the antenna exceeds 6 dBi.

3.3.2 Measuring Instruments

The measuring equipment is listed in the section 4 of this test report.

3.3.3 Test Procedures

The testing follows FCC KDB 789033 D02 General UNII Test Procedures New Rules v01r02. Section F) Maximum power spectral density.

Method SA-2

(trace averaging across on and off times of the EUT transmissions, followed by duty cycle correction).

1. The testing follows Method SA-2 of FCC KDB 789033 D02 General UNII Test Procedures New Rules v01r02.
 - Measure the duty cycle.
 - Set span to encompass the entire emission bandwidth (EBW) of the signal.
 - Set RBW = 1 MHz.
 - Set VBW \geq 3 MHz.
 - Number of points in sweep \geq 2 Span / RBW.
 - Sweep time = auto.
 - Detector = RMS
 - Trace average at least 100 traces in power averaging mode.
 - Add $10 \log(1/x)$, where x is the duty cycle, to the measured power in order to compute the average power during the actual transmission times. For example, add $10 \log(1/0.25) = 6$ dB if the duty cycle is 25 percent.

2. The RF output of EUT was connected to the spectrum analyzer by a low loss cable.
3. Each plot has already offset with cable loss, and attenuator loss. Measure the PPSD and record it.
4. For MIMO mode, calculation method follows FCC KDB 662911 D01 Multiple Transmitter Output v02r01.

Method (1): Measure and sum the spectra across the outputs.

The total final Power Spectral Density is from a device with 2 transmitter outputs. The spectrum measurements of the individual outputs are all performed with the same span and number of points, the spectrum value in the first spectral bin of output 1 is summed with that in the first spectral bin of output 2 to obtain the value for the first frequency bin of the summed spectrum.

3.3.4 Test Setup

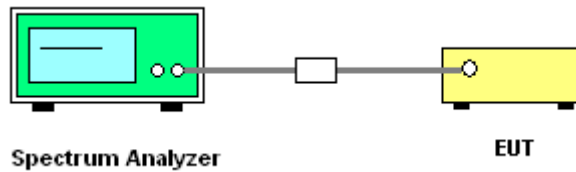



3.3.5 Test Result of Power Spectral Density

Please refer to Appendix A.

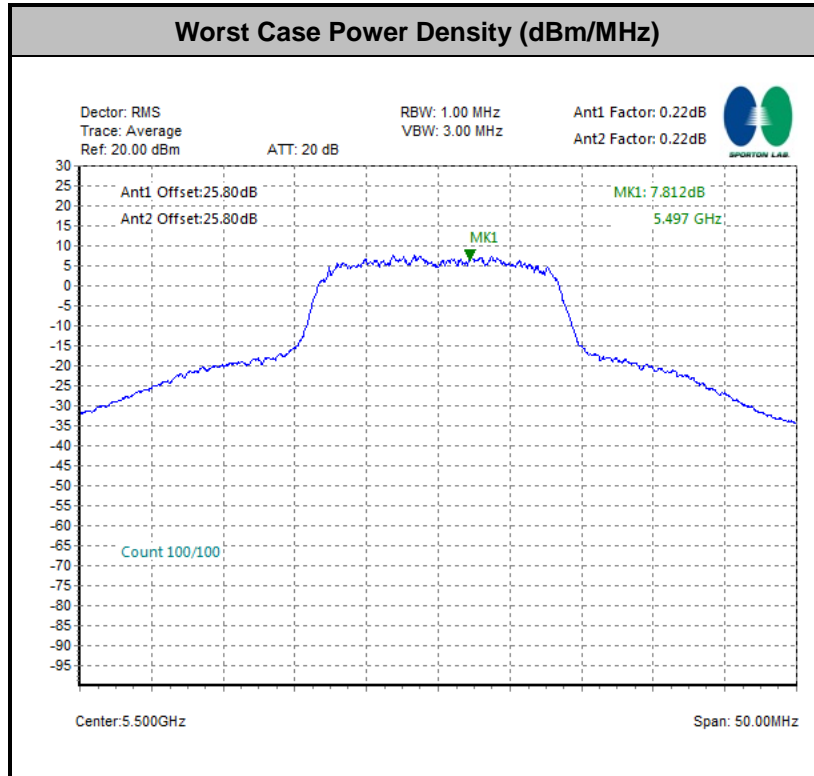

Note: Average Power Density (dB) = Measured value+ Duty Factor



3.4 Unwanted Emissions Measurement

This section as specified in FCC Part 15.407(b) is to measure unwanted emissions through radiated measurement for band edge spurious emissions and out of band emissions measurement. The unwanted emissions shall comply with 15.407(b)(1) to (6), and restricted bands per FCC Part15.205.

3.4.1 Limit of Unwanted Emissions

(1) For transmitters operating in the 5150-5250 MHz band: all emissions outside of the 5150-5350 MHz band shall not exceed an EIRP of -27dBm/MHz.

For transmitters operating in the 5250-5350 MHz band: all emissions outside of the 5150-5350 MHz band shall not exceed an EIRP of -27 dBm/MHz. Devices operating in the 5250-5350 MHz band that generate emissions in the 5150-5250 MHz band must meet all applicable technical requirements for operation in the 5150-5250 MHz band (including indoor use) or alternatively meet an out-of-band emission EIRP limit of -27 dBm/MHz in the 5150-5250 MHz band. For transmitters operating in the 5470-5600 MHz and 5650-5725MHz band: all emissions outside of the 5470-5600 MHz and 5650-5725MHz band shall not exceed an EIRP of -27 dBm/MHz.

(2) Unwanted spurious emissions fallen in restricted bands per FCC Part15.205 shall comply with the general field strength limits set forth in § 15.209 as below table,

Frequency (MHz)	Field Strength (microvolts/meter)	Measurement Distance (meters)
0.009 – 0.490	2400/F(kHz)	300
0.490 – 1.705	24000/F(kHz)	30
1.705 – 30.0	30	30
30 – 88	100	3
88 – 216	150	3
216 - 960	200	3
Above 960	500	3

Note: The following formula is used to convert the EIRP to field strength.

$$E = \frac{1000000\sqrt{30P}}{3} \mu\text{V/m, where P is the eirp (Watts)}$$

EIRP (dBm)	Field Strength at 3m (dBμV/m)
-17	78.3
- 27	68.3

(3) KDB789033 D02 v01r02 G)2)c) As specified in 15.407(b), emissions above 1000 MHz that are outside of the restricted bands are subject to a peak emission limit of -27 dBm/MHz (or -17



dBm/MHz as specified in 15.407(b)(4)). However, an out-of-band emission that complies with both the average and peak limits of 15.209 is not required to satisfy the -27 dBm/MHz or -17 dBm/MHz peak emission limit.

3.4.2 Measuring Instruments

The measuring equipment is listed in the section 4 of this test report.

3.4.3 Test Procedures

1. The testing follows FCC KDB 789033 D02 General UNII Test Procedures New Rules v01r02. Section G) Unwanted emissions measurement.
 - (1) Procedure for Unwanted Emissions Measurements Below 1000MHz
 - RBW = 120 kHz
 - VBW = 300 kHz
 - Detector = Peak
 - Trace mode = max hold
 - (2) Procedure for Peak Unwanted Emissions Measurements Above 1000 MHz
 - RBW = 1 MHz
 - VBW \geq 3 MHz
 - Detector = Peak
 - Sweep time = auto
 - Trace mode = max hold
 - (3) Procedures for Average Unwanted Emissions Measurements Above 1000MHz
 - RBW = 1 MHz
 - VBW = 10 Hz, when duty cycle is no less than 98 percent.
 - VBW \geq 1/T, when duty cycle is less than 98 percent where T is the minimum transmission duration over which the transmitter is on and is transmitting at its maximum power control level for the tested mode of operation.
2. The EUT was placed on a turntable with 0.8 meter for frequency below 1GHz and 1.5 meter for frequency above 1GHz respectively above ground.
3. The EUT was set 3 meters from the interference receiving antenna which was mounted on the top of a variable height antenna tower.
4. The antenna is a broadband antenna and its height is adjusted between one meter and four meters above ground to find the maximum value of the field strength for both horizontal polarization and vertical polarization of the antenna.
5. For each suspected emission, the EUT was arranged to its worst case and then adjust the antenna tower (from 1 m to 4 m) and turntable (from 0 degree to 360 degrees) to find the

maximum reading.

6. For testing below 1GHz, if the emission level of the EUT in peak mode was 3 dB lower than the limit specified, then peak values of EUT will be reported, otherwise, the emissions will be repeated one by one using the CISPR quasi-peak method and reported.
7. For testing above 1GHz, the emission level of the EUT in peak mode was 20dB lower than average limit (that means the emission level in average mode also complies with the limit in average mode), then peak values of EUT will be reported, otherwise, the emissions will be measured in average mode again and reported.

3.4.4 Test Setup

For radiated emissions below 30MHz

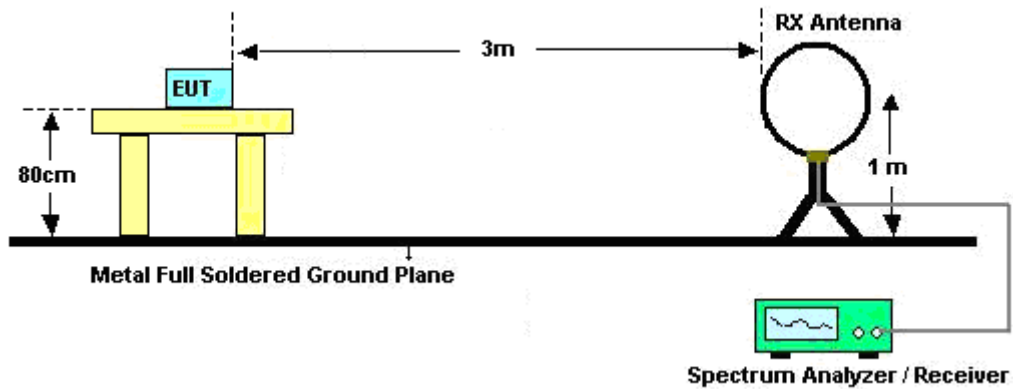

For radiated emissions from 30MHz to 1GHz

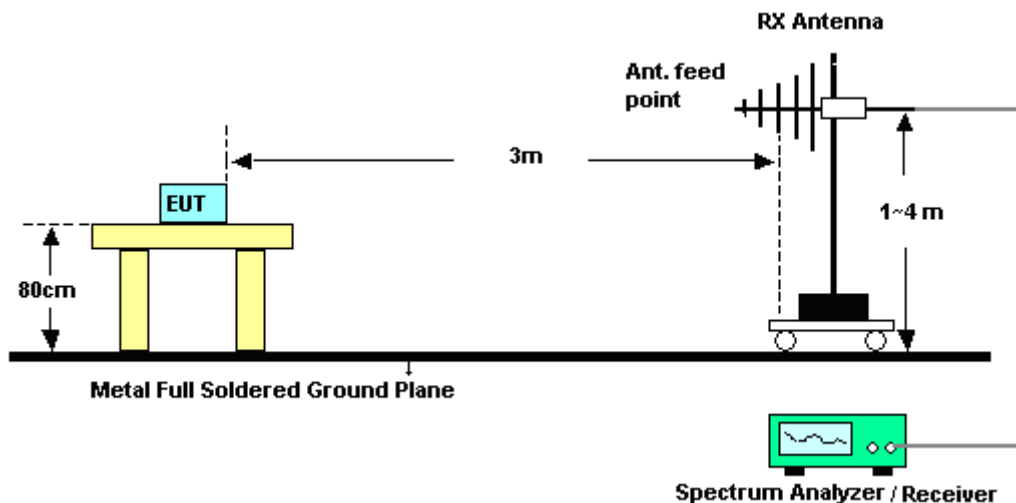

For radiated emissions above 1GHz

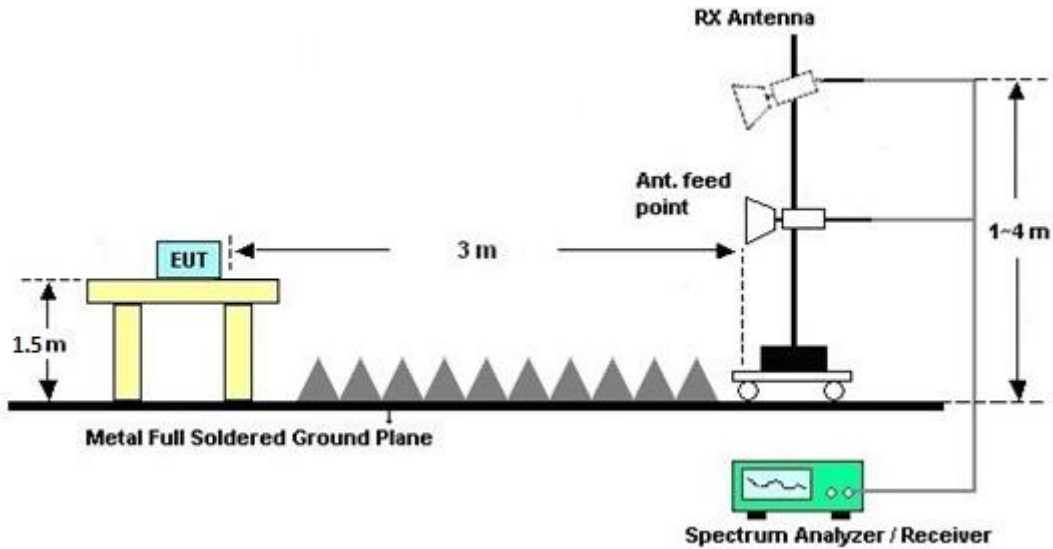

3.4.5 Test Results of Radiated Emissions (9 kHz ~ 30 MHz)

The low frequency, which started from 9 kHz to 30MHz, was pre-scanned and the result which was 20dB lower than the limit line per 15.31(o) was not reported.

3.4.6 Test Result of Radiated Band Edges

Please refer to Appendix B and C

3.4.7 Duty Cycle

Please refer to Appendix D.

3.4.8 Test Result of Unwanted Radiated Emission (30MHz ~ 10th Harmonic)

Please refer to Appendix B and C



3.5 AC Conducted Emission Measurement

3.5.1 Limit of AC Conducted Emission

For equipment that is designed to be connected to the public utility (AC) power line, the radio frequency voltage that is conducted back onto the AC power line on any frequency or frequencies within the band 150 kHz to 30 MHz shall not exceed the limits in the following table.

Frequency of emission (MHz)	Conducted limit (dBµV)	
	Quasi-peak	Average
0.15-0.5	66 to 56*	56 to 46*
0.5-5	56	46
5-30	60	50

*Decreases with the logarithm of the frequency.

3.5.2 Measuring Instruments

The measuring equipment is listed in the section 4 of this test report.

3.5.3 Test Procedures

1. The EUT was placed 0.4 meter from the conducting wall of the shielding room was kept at least 80 centimeters from any other grounded conducting surface.
2. Connect EUT to the power mains through a line impedance stabilization network (LISN).
3. All the support units are connecting to the other LISN.
4. The LISN provides 50 ohm coupling impedance for the measuring instrument.
5. The FCC states that a 50 ohm, 50 microhenry LISN should be used.
6. Both sides of AC line were checked for maximum conducted interference.
7. The frequency range from 150 kHz to 30 MHz was searched.
8. Set the test-receiver system to Peak Detect Function and specified bandwidth with Maximum Hold Mode.

3.5.4 Test Setup

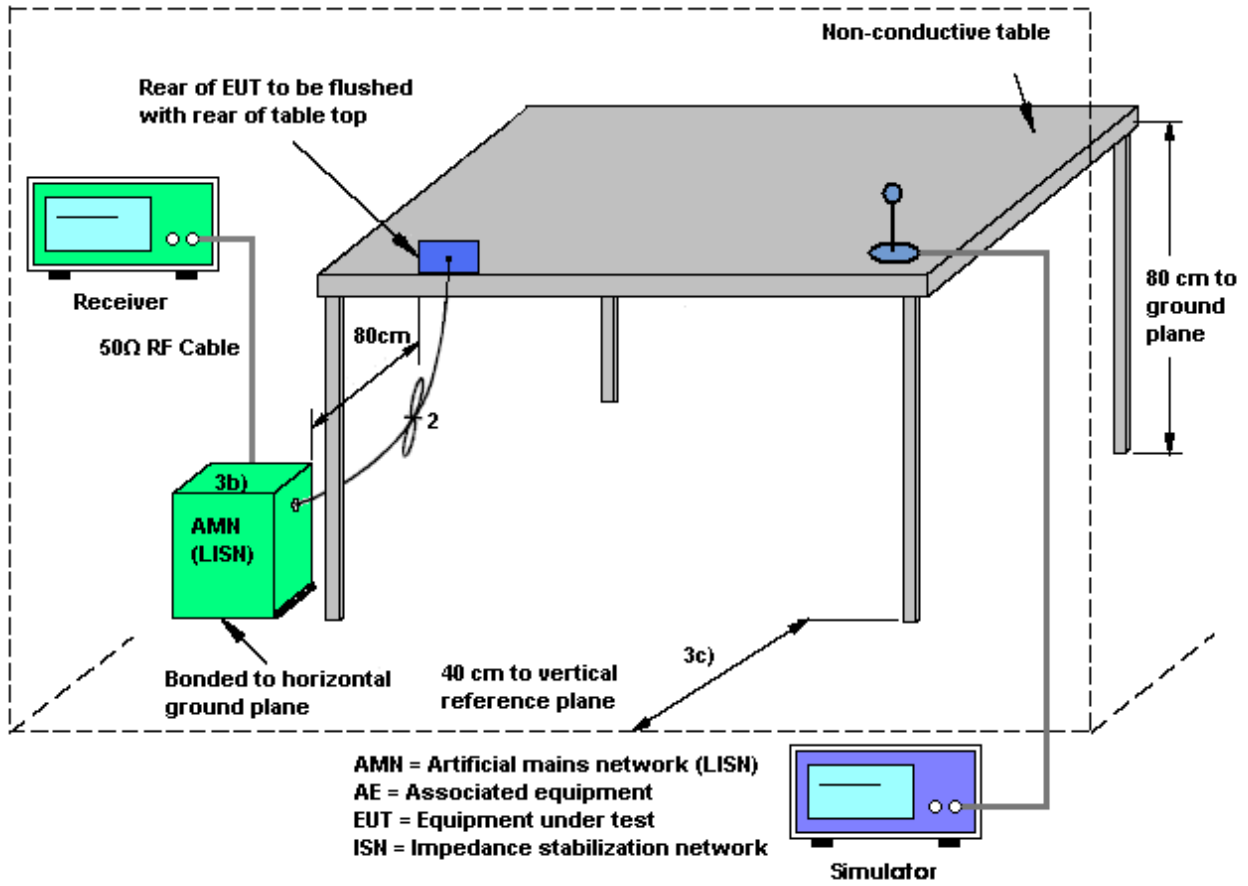



3.5.5 Test Result of AC Conducted Emission

Test Mode :	Mode 1	Temperature :	21~22°C
Test Engineer :	Derreck Chen	Relative Humidity :	47~48%
Test Voltage :	120Vac / 60Hz	Phase :	Line
Function Type :	GSM850 Idle + Bluetooth Link + WLAN (5GHz) Link + Adapter + MP3		

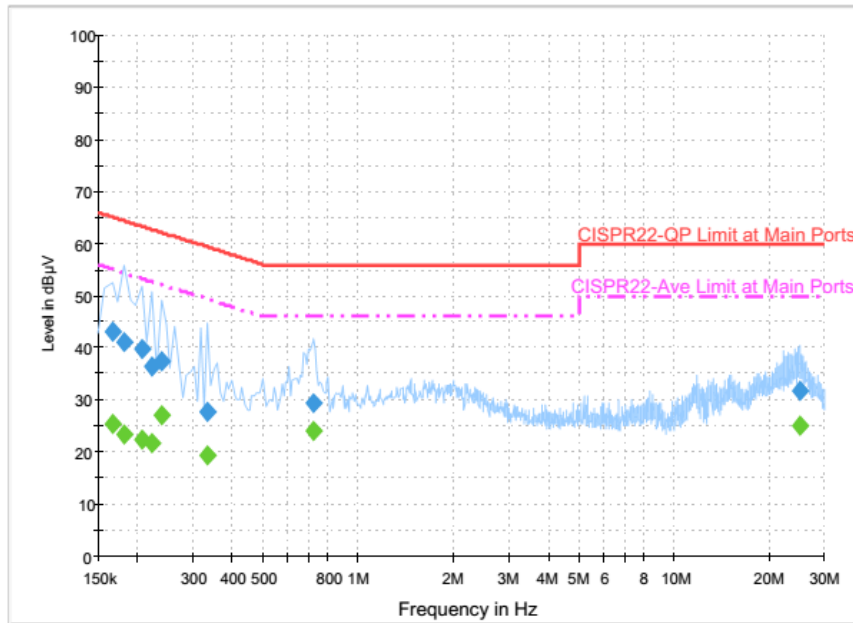

Final Result : QuasiPeak

Frequency (MHz)	QuasiPeak (dBµV)	Filter	Line	Corr. (dB)	Margin (dB)	Limit (dBµV)
0.166000	43.3	Off	L1	19.6	21.9	65.2
0.182000	41.0	Off	L1	19.6	23.4	64.4
0.206000	39.9	Off	L1	19.6	23.5	63.4
0.222000	36.3	Off	L1	19.6	26.4	62.7
0.238000	37.5	Off	L1	19.6	24.7	62.2
0.334000	27.9	Off	L1	19.6	31.5	59.4
0.726000	29.4	Off	L1	19.6	26.6	56.0
25.134000	31.7	Off	L1	19.9	28.3	60.0

Final Result : Average

Frequency (MHz)	Average (dBµV)	Filter	Line	Corr. (dB)	Margin (dB)	Limit (dBµV)
0.166000	25.3	Off	L1	19.6	29.9	55.2
0.182000	23.6	Off	L1	19.6	30.8	54.4
0.206000	22.3	Off	L1	19.6	31.1	53.4
0.222000	21.8	Off	L1	19.6	30.9	52.7
0.238000	27.3	Off	L1	19.6	24.9	52.2
0.334000	19.5	Off	L1	19.6	29.9	49.4
0.726000	24.2	Off	L1	19.6	21.8	46.0
25.134000	25.1	Off	L1	19.9	24.9	50.0



Test Mode :	Mode 1	Temperature :	21~22°C
Test Engineer :	Derreck Chen	Relative Humidity :	47~48%
Test Voltage :	120Vac / 60Hz	Phase :	Neutral
Function Type :	GSM850 Idle + Bluetooth Link + WLAN (5GHz) Link + Adapter + MP3		

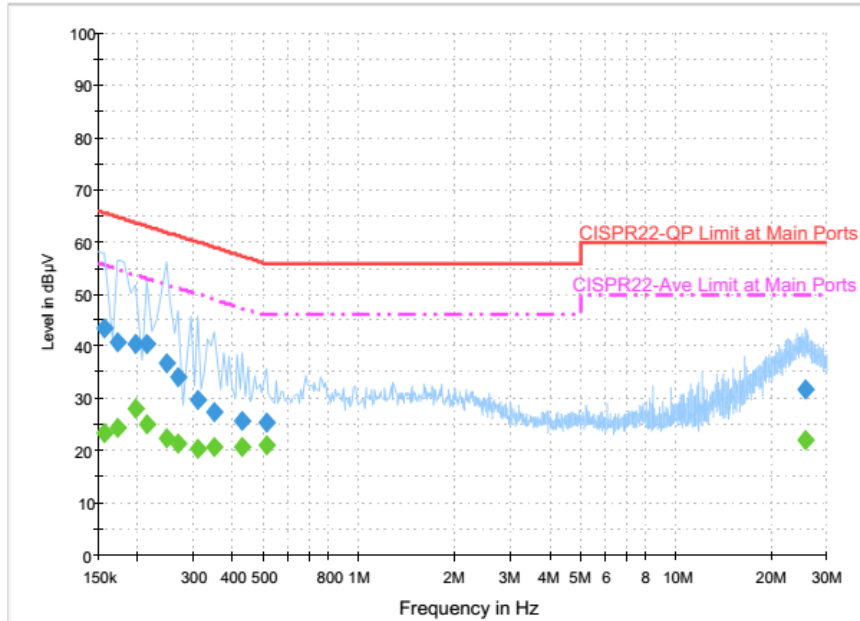

Final Result : QuasiPeak

Frequency (MHz)	QuasiPeak (dBµV)	Filter	Line	Corr. (dB)	Margin (dB)	Limit (dBµV)
0.158000	43.6	Off	N	19.6	22.0	65.6
0.174000	40.9	Off	N	19.6	23.9	64.8
0.198000	40.4	Off	N	19.6	23.3	63.7
0.214000	40.6	Off	N	19.6	22.4	63.0
0.246000	36.8	Off	N	19.6	25.1	61.9
0.270000	34.0	Off	N	19.6	27.1	61.1
0.310000	29.9	Off	N	19.6	30.1	60.0
0.350000	27.4	Off	N	19.6	31.6	59.0
0.430000	25.8	Off	N	19.6	31.5	57.3
0.510000	25.3	Off	N	19.6	30.7	56.0
25.702000	31.8	Off	N	20.0	28.2	60.0



Test Mode :	Mode 1	Temperature :	21~22°C
Test Engineer :	Derreck Chen	Relative Humidity :	47~48%
Test Voltage :	120Vac / 60Hz	Phase :	Neutral
Function Type :	GSM850 Idle + Bluetooth Link + WLAN (5GHz) Link + Adapter + MP3		

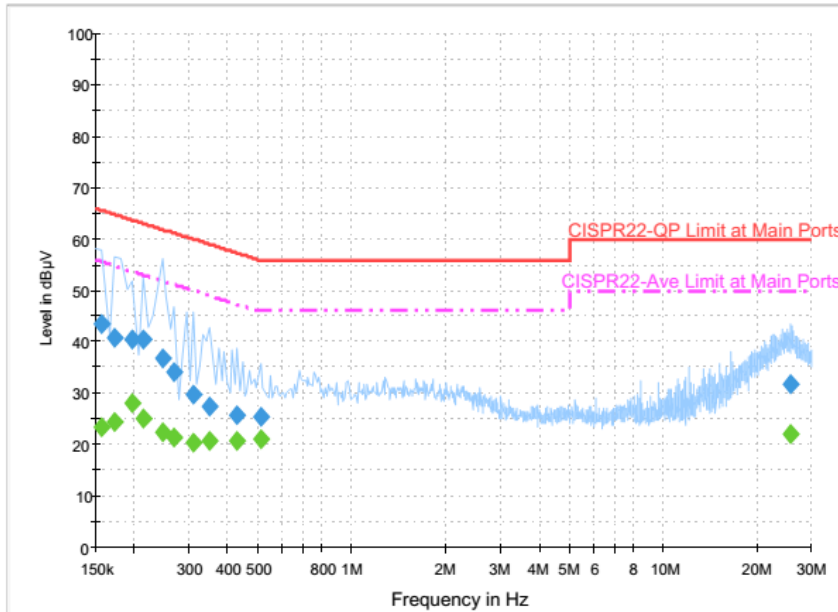

Final Result : Average

Frequency (MHz)	Average (dBµV)	Filter	Line	Corr. (dB)	Margin (dB)	Limit (dBµV)
0.158000	23.4	Off	N	19.6	32.2	55.6
0.174000	24.3	Off	N	19.6	30.5	54.8
0.198000	28.2	Off	N	19.6	25.5	53.7
0.214000	24.9	Off	N	19.6	28.1	53.0
0.246000	22.5	Off	N	19.6	29.4	51.9
0.270000	21.3	Off	N	19.6	29.8	51.1
0.310000	20.4	Off	N	19.6	29.6	50.0
0.350000	20.6	Off	N	19.6	28.4	49.0
0.430000	20.8	Off	N	19.6	26.5	47.3
0.510000	20.9	Off	N	19.6	25.1	46.0
25.702000	21.9	Off	N	20.0	28.1	50.0

3.6 Frequency Stability Measurement

3.6.1 Limit of Frequency Stability

Manufacturers of U-NII devices are responsible for ensuring frequency stability such that an emission is maintained within the band of operation under all conditions of normal operation as specified in the user's manual.

3.6.2 Measuring Instruments

The measuring equipment is listed in the section 4 of this test report.

3.6.3 Test Procedures

1. To ensure emission at the band edge is maintained within the authorized band, those values shall be measured by radiation emissions at upper and lower frequency points, and finally compensated by frequency deviation as procedures below.
2. The EUT was operated at the maximum output power, and connected to the spectrum analyzer, which is set to maximum hold function and peak detector. The peak value of the power envelope was measured and noted. The upper and lower frequency points were respectively measured relatively 10dB lower than the measured peak value.
3. The frequency deviation was calculated by adding the upper frequency point and the lower frequency point divided by two. Those detailed values of frequency deviation are provided in table below.

3.6.4 Test Setup

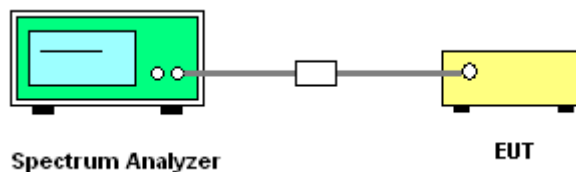

3.6.5 Test Result of Frequency Stability

Please refer to Appendix A.



3.7 Automatically Discontinue Transmission

3.7.1 Limit of Automatically Discontinue Transmission

The device shall automatically discontinue transmission in case of either absence of information to transmit or operational failure. These provisions are not intended to preclude the transmission of control or signaling information or the use of repetitive codes used by certain digital technologies to complete frame or burst intervals. Applicants shall include in their application for equipment authorization to describe how this requirement is met.

3.7.2 Measuring Instruments

The measuring equipment is listed in the section 4 of this test report.

3.7.3 Test Result of Automatically Discontinue Transmission

While the EUT is not transmitting any information, the EUT can automatically discontinue transmission and become standby mode for power saving. The EUT can detect the controlling signal of ACK message transmitting from remote device and verify whether it shall resend or discontinue transmission.



3.8 Antenna Requirements

3.8.1 Standard Applicable

According to FCC 47 CFR Section 15.407(a)(1)(2) ,if transmitting antenna directional gain is greater than 6 dBi, both the peak transmit power and the peak power spectral density shall be reduced by the amount in dB that the directional gain of the antenna exceeds 6 dBi.

3.8.2 Antenna Anti-Replacement Construction

An embedded-in antenna design is used.

3.8.3 Antenna Gain

FCC KDB 662911 D01 Multiple Transmitter Output v02r01

For CDD transmissions, directional gain is calculated as

Directional gain = $G_{ANT} + \text{Array Gain}$, where Array Gain is as follows.

For power spectral density (PSD) measurements on all devices,

Array Gain = $10 \log(N_{ANT}/N_{SS}=1)$ dB.

For power measurements on IEEE 802.11 devices,

Array Gain = 0 dB (i.e., no array gain) for $N_{ANT} \leq 4$.

Directional gain may be calculated by using the formulas applicable to equal gain antennas with G_{ANT} set equal to the gain of the antenna having the highest gain;

The EUT supports CDD mode.

The power and PSD limit should be modified if the directional gain of EUT is over 6 dBi,

The directional gain “DG” is calculated as following table.

	Ant 1	Ant 2	DG for Power (dBi)	DG for PSD (dBi)	Power Limit Reduction (dB)	PSD Limit Reduction (dB)
Band I	0.00	-7.00	0.00	0.20	0.00	0.00
Band II	1.00	-6.50	1.00	1.05	0.00	0.00
Band III	2.00	-6.50	2.00	1.76	0.00	0.00

Power limit reduction = Composite gain – 6dBi, (min = 0)

PSD limit reduction = Composite gain + PSD Array gain – 6dBi, (min = 0)



4 List of Measuring Equipment

Instrument	Manufacturer	Model No.	Serial No.	Characteristics	Calibration Date	Test Date	Due Date	Remark
DC Power Supply	TOPWARD	3303D	740889	N/A	May 27, 2015	Apr. 01, 2016 ~ Apr. 25, 2016	May 26, 2016	Conducted (TH02-HY)
Power Meter	Anritsu	ML2495A	1036004	300MHz~40GHz	Jul. 29, 2015	Apr. 01, 2016 ~ Apr. 25, 2016	Jul. 28, 2016	Conducted (TH02-HY)
Power Sensor	Anritsu	MA2411B	1027253	300MHz~40GHz	Jul. 29, 2015	Apr. 01, 2016 ~ Apr. 25, 2016	Jul. 28, 2016	Conducted (TH02-HY)
Spectrum Analyzer	Rohde & Schwarz	FSP40	100055	9kHz~40GHz	Jun. 18, 2015	Apr. 01, 2016 ~ Apr. 25, 2016	Jun. 17, 2016	Conducted (TH02-HY)
Thermal Chamber	Ten Billion	TTH-D3SP	TBN-930701	N/A	Jul. 16, 2015	Apr. 01, 2016 ~ Apr. 25, 2016	Jul. 15, 2016	Conducted (TH02-HY)
AC Power Source	ChainTek	APC-1000W	N/A	N/A	N/A	Apr. 06, 2016	N/A	Conduction (CO05-HY)
EMI Test Receiver	Rohde & Schwarz	ESCI 7	100724	9kHz~7GHz	Aug. 26, 2015	Apr. 06, 2016	Aug. 25, 2016	Conduction (CO05-HY)
LISN	Rohde & Schwarz	ENV216	100080	9kHz~30MHz	Dec. 02, 2015	Apr. 06, 2016	Dec. 01, 2016	Conduction (CO05-HY)
Loop Antenna	Rohde & Schwarz	HFH2-Z2	100315	9 kHz~30 MHz	Sep. 02, 2015	Apr. 11, 2016 ~ Apr. 14, 2016	Sep. 01, 2016	Radiation (03CH11-HY)
Amplifier	SONOMA	310N	187312	9kHz~1GHz	Nov. 20, 2015	Apr. 11, 2016 ~ Apr. 14, 2016	Nov. 19, 2016	Radiation (03CH11-HY)
Bilog Antenna	TESEQ	CBL 6111D	35414	30MHz~1GHz	Nov. 17, 2015	Apr. 11, 2016 ~ Apr. 14, 2016	Nov. 16, 2016	Radiation (03CH11-HY)
Horn Antenna	SCHWARZBECK	BBHA 9120 D	9120D-1326	1GHz ~ 18GHz	Oct. 08, 2015	Apr. 11, 2016 ~ Apr. 14, 2016	Oct. 07, 2016	Radiation (03CH11-HY)
Preamplifier	Keysight	83017A	MY53270080	1GHz~26.5GHz	Nov. 19, 2015	Apr. 11, 2016 ~ Apr. 14, 2016	Nov. 18, 2016	Radiation (03CH11-HY)
Preamplifier	MITEQ	AMF-7D-0010 1800-30-10P	1902247	1GHz~18GHz	Jul. 01, 2015	Apr. 11, 2016 ~ Apr. 14, 2016	Jun. 30, 2016	Radiation (03CH11-HY)
Spectrum Analyzer	Keysight	N9010A	MY54200486	10Hz ~ 44GHZ	Sep. 24, 2015	Apr. 11, 2016 ~ Apr. 14, 2016	Sep. 23, 2016	Radiation (03CH11-HY)
Controller	EMEC	EM 1000	N/A	Control Turn table & Ant Mast	N/A	Apr. 11, 2016 ~ Apr. 14, 2016	N/A	Radiation (03CH11-HY)
Antenna Mast	EMEC	AM-BS-4500-B	N/A	1~4m	N/A	Apr. 11, 2016 ~ Apr. 14, 2016	N/A	Radiation (03CH11-HY)
Turn Table	EMEC	TT 2000	N/A	0~360 Degree	N/A	Apr. 11, 2016 ~ Apr. 14, 2016	N/A	Radiation (03CH11-HY)
SHF-EHF Horn Antenna	SCHWARZBECK	BBHA 9170	BBHA917058 4	18GHz- 40GHz	Nov. 02, 2015	Apr. 11, 2016 ~ Apr. 14, 2016	Nov. 01, 2016	Radiation (03CH11-HY)



5 Uncertainty of Evaluation

Uncertainty of Conducted Emission Measurement (150kHz ~ 30MHz)

Measuring Uncertainty for a Level of Confidence of 95% ($U = 2Uc(y)$)	2.26
---	------

Uncertainty of Radiated Emission Measurement (30 MHz ~ 1000 MHz)

Measuring Uncertainty for a Level of Confidence of 95% ($U = 2Uc(y)$)	4.9
---	-----



Appendix A. Conducted Test Results

Test Engineer:	AC Chang	Temperature:	21~25	°C
Test Date:	2016/04/01 ~ 2016/04/25	Relative Humidity:	51~54	%

TEST RESULTS DATA
26dB and 99% OBW

Band I													
Mod.	Data Rate	NTX	CH.	Freq. (MHz)	99% Bandwidth (MHz)		26 dB Bandwidth (MHz)		IC 99% Bandwidth Power Limit (dBm)		IC 99% Bandwidth EIRP Limit (dBm)		Note
					Ant 1	Ant 2	Ant 1	Ant 2	Ant 1	Ant 2	Ant 1	Ant 2	
11a	6Mbps	1	36	5180	17.15	17.00	28.70	24.40	-	-	22.34	22.30	
11a	6Mbps	1	44	5220	17.25	17.00	31.80	27.90	-	-	22.37	22.30	
11a	6Mbps	1	48	5240	17.15	17.00	30.90	24.90	-	-	22.34	22.30	
HT20	MCS0	1	36	5180	18.05	17.95	29.50	23.20	-	-	22.56	22.54	
HT20	MCS0	1	44	5220	18.10	17.90	32.00	25.50	-	-	22.58	22.53	
HT20	MCS0	1	48	5240	18.05	17.95	29.70	25.00	-	-	22.56	22.54	
HT40	MCS0	1	38	5190	36.10	36.10	44.46	46.26	-	-	23.01	23.01	
HT40	MCS0	1	46	5230	36.10	36.20	47.88	41.40	-	-	23.01	23.01	
VHT20	MCS0	1	36	5180	18.20	18.10	32.70	25.70	-	-	22.60	22.58	
VHT20	MCS0	1	44	5220	18.20	17.90	33.60	24.40	-	-	22.60	22.53	
VHT20	MCS0	1	48	5240	18.40	17.90	34.20	23.60	-	-	22.65	22.53	
VHT40	MCS0	1	38	5190	36.00	36.20	45.90	44.64	-	-	23.01	23.01	
VHT40	MCS0	1	46	5230	36.20	36.10	50.04	44.46	-	-	23.01	23.01	
VHT80	MCS0	1	42	5210	75.24	75.12	82.24	85.12	-	-	23.01	23.01	
11a	6Mbps	2	36	5180	17.20	16.95	33.40	24.00	-	-	22.29		
11a	6Mbps	2	44	5220	17.20	17.05	31.90	29.90	-	-	22.32		
11a	6Mbps	2	48	5240	17.20	17.05	31.60	29.40	-	-	22.32		
HT20	MCS0	2	36	5180	18.15	18.05	29.90	25.10	-	-	22.56		
HT20	MCS0	2	44	5220	18.00	17.95	26.20	24.20	-	-	22.54		
HT20	MCS0	2	48	5240	18.10	18.05	29.90	27.10	-	-	22.56		
HT40	MCS0	2	38	5190	36.20	36.20	47.52	50.04	-	-	23.01		
HT40	MCS0	2	46	5230	36.20	36.20	46.44	43.56	-	-	23.01		
VHT20	MCS0	2	36	5180	18.10	18.00	32.10	24.40	-	-	22.55		
VHT20	MCS0	2	44	5220	18.05	18.05	29.30	25.00	-	-	22.56		
VHT20	MCS0	2	48	5240	18.35	18.00	35.00	24.50	-	-	22.55		
VHT40	MCS0	2	38	5190	36.10	36.10	46.26	49.68	-	-	23.01		
VHT40	MCS0	2	46	5230	36.20	36.10	49.32	54.00	-	-	23.01		
VHT80	MCS0	2	42	5210	75.24	75.24	82.56	81.28	-	-	23.01		

TEST RESULTS DATA
Average Power Table

FCC Band I														
Mod.	Data Rate	NTX	CH.	Freq. (MHz)	Duty Factor (dB)		Average Conducted Power (dBm)			FCC Conducted Power Limit (dBm)		DG (dBi)		Pass/Fail
					Ant 1	Ant 2	Ant 1	Ant 2	SUM	Ant 1	Ant 2	Ant 1	Ant 2	
11a	6Mbps	1	36	5180	0.22	0.20	16.30	15.79		24.00	24.00	0.00	-7.00	Pass
11a	6Mbps	1	44	5220	0.22	0.20	16.23	15.69		24.00	24.00	0.00	-7.00	Pass
11a	6Mbps	1	48	5240	0.22	0.20	16.26	15.76		24.00	24.00	0.00	-7.00	Pass
HT20	MCS0	1	36	5180	0.22	0.24	16.17	15.52		24.00	24.00	0.00	-7.00	Pass
HT20	MCS0	1	44	5220	0.22	0.24	15.98	15.40		24.00	24.00	0.00	-7.00	Pass
HT20	MCS0	1	48	5240	0.22	0.24	16.09	15.46		24.00	24.00	0.00	-7.00	Pass
HT40	MCS0	1	38	5190	0.43	0.48	13.78	13.43		24.00	24.00	0.00	-7.00	Pass
HT40	MCS0	1	46	5230	0.43	0.48	14.25	14.00		24.00	24.00	0.00	-7.00	Pass
VHT20	MCS0	1	36	5180	0.22	0.22	16.21	15.74		24.00	24.00	0.00	-7.00	Pass
VHT20	MCS0	1	44	5220	0.22	0.22	16.07	15.72		24.00	24.00	0.00	-7.00	Pass
VHT20	MCS0	1	48	5240	0.22	0.22	16.18	15.69		24.00	24.00	0.00	-7.00	Pass
VHT40	MCS0	1	38	5190	0.48	0.46	13.59	13.03		24.00	24.00	0.00	-7.00	Pass
VHT40	MCS0	1	46	5230	0.48	0.46	14.56	13.97		24.00	24.00	0.00	-7.00	Pass
VHT80	MCS0	1	42	5210	0.85	0.85	13.42	12.62		24.00	24.00	0.00	-7.00	Pass
11a	6Mbps	2	36	5180	0.22	0.22	15.43	15.07	18.27	24.00		0.00		Pass
11a	6Mbps	2	44	5220	0.22	0.22	15.40	14.98	18.21	24.00		0.00		Pass
11a	6Mbps	2	48	5240	0.22	0.22	15.38	14.94	18.18	24.00		0.00		Pass
HT20	MCS0	2	36	5180	0.23	0.22	15.18	14.94	18.07	24.00		0.00		Pass
HT20	MCS0	2	44	5220	0.23	0.22	15.14	14.83	18.00	24.00		0.00		Pass
HT20	MCS0	2	48	5240	0.23	0.22	15.15	14.87	18.02	24.00		0.00		Pass
HT40	MCS0	2	38	5190	0.43	0.48	13.24	12.83	16.05	24.00		0.00		Pass
HT40	MCS0	2	46	5230	0.43	0.48	13.82	13.29	16.57	24.00		0.00		Pass
VHT20	MCS0	2	36	5180	0.22	0.24	15.37	15.06	18.23	24.00		0.00		Pass
VHT20	MCS0	2	44	5220	0.22	0.24	15.33	14.97	18.16	24.00		0.00		Pass
VHT20	MCS0	2	48	5240	0.22	0.24	15.24	15.06	18.16	24.00		0.00		Pass
VHT40	MCS0	2	38	5190	0.43	0.43	12.86	12.44	15.67	24.00		0.00		Pass
VHT40	MCS0	2	46	5230	0.43	0.43	13.82	13.24	16.55	24.00		0.00		Pass
VHT80	MCS0	2	42	5210	0.85	0.85	12.71	12.36	15.55	24.00		0.00		Pass

TEST RESULTS DATA
Power Spectral Density

FCC Band I														
Mod.	Data Rate	NTX	CH.	Freq. (MHz)	Duty Factor (dB)		Average Power Density (dBm/MHz)			Average PSD Limit (dBm/MHz)		DG (dBi)		Pass /Fail
					Ant 1	Ant 2	Ant 1	Ant 2	SUM	Ant 1	Ant 2	Ant 1	Ant 2	
11a	6Mbps	1	36	5180	0.22	0.20	4.76	4.23		11.00	11.00	0.00	-7.00	Pass
11a	6Mbps	1	44	5220	0.22	0.20	4.83	4.59		11.00	11.00	0.00	-7.00	Pass
11a	6Mbps	1	48	5240	0.22	0.20	4.97	4.84		11.00	11.00	0.00	-7.00	Pass
HT20	MCS0	1	36	5180	0.22	0.24	4.48	4.28		11.00	11.00	0.00	-7.00	Pass
HT20	MCS0	1	44	5220	0.22	0.24	4.41	4.39		11.00	11.00	0.00	-7.00	Pass
HT20	MCS0	1	48	5240	0.22	0.24	4.77	4.68		11.00	11.00	0.00	-7.00	Pass
HT40	MCS0	1	38	5190	0.43	0.48	-0.63	-0.72		11.00	11.00	0.00	-7.00	Pass
HT40	MCS0	1	46	5230	0.43	0.48	0.15	0.39		11.00	11.00	0.00	-7.00	Pass
VHT20	MCS0	1	36	5180	0.22	0.22	4.92	4.14		11.00	11.00	0.00	-7.00	Pass
VHT20	MCS0	1	44	5220	0.22	0.22	4.35	3.83		11.00	11.00	0.00	-7.00	Pass
VHT20	MCS0	1	48	5240	0.22	0.22	4.14	3.81		11.00	11.00	0.00	-7.00	Pass
VHT40	MCS0	1	38	5190	0.48	0.46	-0.87	-1.15		11.00	11.00	0.00	-7.00	Pass
VHT40	MCS0	1	46	5230	0.48	0.46	-0.54	-0.54		11.00	11.00	0.00	-7.00	Pass
VHT80	MCS0	1	42	5210	0.85	0.85	-4.14	-4.93		11.00	11.00	0.00	-7.00	Pass
11a	6Mbps	2	36	5180	0.22	0.22			6.65	11.00		0.20		Pass
11a	6Mbps	2	44	5220	0.22	0.22			6.29	11.00		0.20		Pass
11a	6Mbps	2	48	5240	0.22	0.22			7.04	11.00		0.20		Pass
HT20	MCS0	2	36	5180	0.23	0.22			5.94	11.00		0.20		Pass
HT20	MCS0	2	44	5220	0.23	0.22			5.53	11.00		0.20		Pass
HT20	MCS0	2	48	5240	0.23	0.22			6.22	11.00		0.20		Pass
HT40	MCS0	2	38	5190	0.43	0.48			-0.45	11.00		0.20		Pass
HT40	MCS0	2	46	5230	0.43	0.48			1.49	11.00		0.20		Pass
VHT20	MCS0	2	36	5180	0.22	0.24			6.14	11.00		0.20		Pass
VHT20	MCS0	2	44	5220	0.22	0.24			5.61	11.00		0.20		Pass
VHT20	MCS0	2	48	5240	0.22	0.24			5.55	11.00		0.20		Pass
VHT40	MCS0	2	38	5190	0.43	0.43			0.42	11.00		0.20		Pass
VHT40	MCS0	2	46	5230	0.43	0.43			0.89	11.00		0.20		Pass
VHT80	MCS0	2	42	5210	0.85	0.85			-4.28	11.00		0.20		Pass

TEST RESULTS DATA
26dB and 99% OBW

Band II															
Mod.	Data Rate	NTX	CH.	Freq. (MHz)	99% Bandwidth (MHz)		26 dB Bandwidth (MHz)		IC 99% Bandwidth Power Limit (dBm)		IC 99% Bandwidth EIRP Limit (dBm)		FCC 26dB Bandwidth Power Limit (dBm)		Note
					Ant 1	Ant 2	Ant 1	Ant 2	Ant 1	Ant 2	Ant 1	Ant 2	Ant 1	Ant 2	
11a	6Mbps	1	52	5260	17.25	16.95	31.40	25.00	23.37	23.29	29.37	29.29	23.98	23.98	
11a	6Mbps	1	60	5300	17.35	16.95	31.90	24.50	23.39	23.29	29.39	29.29	23.98	23.98	
11a	6Mbps	1	64	5320	17.10	17.00	28.00	23.80	23.33	23.30	29.33	29.30	23.98	23.98	
HT20	MCS0	1	52	5260	18.20	17.90	31.70	24.70	23.60	23.53	29.60	29.53	23.98	23.98	
HT20	MCS0	1	60	5300	18.15	17.95	30.10	23.80	23.59	23.54	29.59	29.54	23.98	23.98	
HT20	MCS0	1	64	5320	18.00	17.85	25.30	24.90	23.55	23.52	29.55	29.52	23.98	23.98	
HT40	MCS0	1	54	5270	36.10	36.10	46.44	46.98	23.98	23.98	30.00	30.00	23.98	23.98	
HT40	MCS0	1	62	5310	36.30	36.20	47.88	45.72	23.98	23.98	30.00	30.00	23.98	23.98	
VHT20	MCS0	1	52	5260	18.20	17.85	30.20	25.20	23.60	23.52	29.60	29.52	23.98	23.98	
VHT20	MCS0	1	60	5300	18.30	17.90	34.00	24.10	23.62	23.53	29.62	29.53	23.98	23.98	
VHT20	MCS0	1	64	5320	18.10	17.90	27.30	24.80	23.58	23.53	29.58	29.53	23.98	23.98	
VHT40	MCS0	1	54	5270	36.30	36.10	47.70	44.64	23.98	23.98	30.00	30.00	23.98	23.98	
VHT40	MCS0	1	62	5310	36.20	36.10	49.14	45.72	23.98	23.98	30.00	30.00	23.98	23.98	
VHT80	MCS0	1	58	5290	75.36	75.00	83.20	80.64	23.98	23.98	30.00	30.00	23.98	23.98	
11a	6Mbps	2	52	5260	17.20	17.05	31.70	25.10	23.32		29.32		23.98		
11a	6Mbps	2	60	5300	17.45	17.00	34.40	24.70	23.30		29.30		23.98		
11a	6Mbps	2	64	5320	17.20	16.95	33.60	23.90	23.29		29.29		23.98		
HT20	MCS0	2	52	5260	18.15	17.95	28.70	22.90	23.54		29.54		23.98		
HT20	MCS0	2	60	5300	18.15	18.00	32.60	23.20	23.55		29.55		23.98		
HT20	MCS0	2	64	5320	18.15	17.90	29.00	22.20	23.53		29.53		23.98		
HT40	MCS0	2	54	5270	36.10	36.10	46.44	47.70	23.98		30.00		23.98		
HT40	MCS0	2	62	5310	36.20	36.10	46.44	49.14	23.98		30.00		23.98		
VHT20	MCS0	2	52	5260	18.10	17.95	29.40	23.70	23.54		29.54		23.98		
VHT20	MCS0	2	60	5300	18.30	17.95	34.60	25.10	23.54		29.54		23.98		
VHT20	MCS0	2	64	5320	18.10	18.00	29.40	24.70	23.55		29.55		23.98		
VHT40	MCS0	2	54	5270	36.10	36.20	49.14	47.16	23.98		30.00		23.98		
VHT40	MCS0	2	62	5310	36.20	36.20	45.90	55.80	23.98		30.00		23.98		
VHT80	MCS0	2	58	5290	75.24	75.00	81.60	85.12	23.98		30.00		23.98		

TEST RESULTS DATA
Average Power Table

FCC Band II														
Mod.	Data Rate	NTX	CH.	Freq. (MHz)	Duty Factor (dB)		Average Conducted Power (dBm)			FCC Conducted Power Limit (dBm)		DG (dBi)		Pass/Fail
					Ant 1	Ant 2	Ant 1	Ant 2	SUM	Ant 1	Ant 2	Ant 1	Ant 2	
11a	6Mbps	1	52	5260	0.22	0.20	16.40	15.76		23.98	23.98	1.00	-6.50	Pass
11a	6Mbps	1	60	5300	0.22	0.20	16.07	15.54		23.98	23.98	1.00	-6.50	Pass
11a	6Mbps	1	64	5320	0.22	0.20	16.04	15.43		23.98	23.98	1.00	-6.50	Pass
HT20	MCS0	1	52	5260	0.22	0.24	16.20	15.56		23.98	23.98	1.00	-6.50	Pass
HT20	MCS0	1	60	5300	0.22	0.24	16.00	15.45		23.98	23.98	1.00	-6.50	Pass
HT20	MCS0	1	64	5320	0.22	0.24	15.86	15.42		23.98	23.98	1.00	-6.50	Pass
HT40	MCS0	1	54	5270	0.43	0.48	14.51	13.89		23.98	23.98	1.00	-6.50	Pass
HT40	MCS0	1	62	5310	0.43	0.48	13.82	13.20		23.98	23.98	1.00	-6.50	Pass
VHT20	MCS0	1	52	5260	0.22	0.22	16.14	15.71		23.98	23.98	1.00	-6.50	Pass
VHT20	MCS0	1	60	5300	0.22	0.22	16.03	15.56		23.98	23.98	1.00	-6.50	Pass
VHT20	MCS0	1	64	5320	0.22	0.22	15.98	15.39		23.98	23.98	1.00	-6.50	Pass
VHT40	MCS0	1	54	5270	0.48	0.46	14.60	13.90		23.98	23.98	1.00	-6.50	Pass
VHT40	MCS0	1	62	5310	0.48	0.46	13.93	13.31		23.98	23.98	1.00	-6.50	Pass
VHT80	MCS0	1	58	5290	0.85	0.85	12.53	11.70		23.98	23.98	1.00	-6.50	Pass
11a	6Mbps	2	52	5260	0.22	0.22	15.68	15.00	18.37	23.98		1.00		Pass
11a	6Mbps	2	60	5300	0.22	0.22	15.31	14.77	18.06	23.98		1.00		Pass
11a	6Mbps	2	64	5320	0.22	0.22	15.30	14.76	18.05	23.98		1.00		Pass
HT20	MCS0	2	52	5260	0.23	0.22	15.18	14.85	18.03	23.98		1.00		Pass
HT20	MCS0	2	60	5300	0.23	0.22	15.08	14.58	17.85	23.98		1.00		Pass
HT20	MCS0	2	64	5320	0.23	0.22	15.22	14.43	17.85	23.98		1.00		Pass
HT40	MCS0	2	54	5270	0.43	0.48	13.98	13.15	16.60	23.98		1.00		Pass
HT40	MCS0	2	62	5310	0.43	0.48	13.26	12.59	15.95	23.98		1.00		Pass
VHT20	MCS0	2	52	5260	0.22	0.24	15.28	14.85	18.08	23.98		1.00		Pass
VHT20	MCS0	2	60	5300	0.22	0.24	15.07	14.65	17.87	23.98		1.00		Pass
VHT20	MCS0	2	64	5320	0.22	0.24	15.23	14.29	17.79	23.98		1.00		Pass
VHT40	MCS0	2	54	5270	0.43	0.43	13.85	13.16	16.53	23.98		1.00		Pass
VHT40	MCS0	2	62	5310	0.43	0.43	13.19	12.45	15.85	23.98		1.00		Pass
VHT80	MCS0	2	58	5290	0.85	0.85	12.21	11.02	14.67	23.98		1.00		Pass

TEST RESULTS DATA
Power Spectral Density

Band II														
Mod.	Data Rate	NTX	CH.	Freq. (MHz)	Duty Factor (dB)		Average Power Density (dBm/MHz)			Average PSD Limit (dBm/MHz)		DG (dBi)		Pass /Fail
					Ant 1	Ant 2	Ant 1	Ant 2	SUM	Ant 1	Ant 2	Ant 1	Ant 2	
11a	6Mbps	1	52	5260	0.22	0.20	5.24	4.76		11.00	11.00	1.00	-6.50	Pass
11a	6Mbps	1	60	5300	0.22	0.20	4.67	4.37		11.00	11.00	1.00	-6.50	Pass
11a	6Mbps	1	64	5320	0.22	0.20	4.54	4.27		11.00	11.00	1.00	-6.50	Pass
HT20	MCS0	1	52	5260	0.22	0.24	5.04	4.57		11.00	11.00	1.00	-6.50	Pass
HT20	MCS0	1	60	5300	0.22	0.24	4.46	4.21		11.00	11.00	1.00	-6.50	Pass
HT20	MCS0	1	64	5320	0.22	0.24	4.58	4.19		11.00	11.00	1.00	-6.50	Pass
HT40	MCS0	1	54	5270	0.43	0.48	0.52	0.07		11.00	11.00	1.00	-6.50	Pass
HT40	MCS0	1	62	5310	0.43	0.48	-0.44	-0.97		11.00	11.00	1.00	-6.50	Pass
VHT20	MCS0	1	52	5260	0.22	0.22	4.15	3.61		11.00	11.00	1.00	-6.50	Pass
VHT20	MCS0	1	60	5300	0.22	0.22	3.82	3.31		11.00	11.00	1.00	-6.50	Pass
VHT20	MCS0	1	64	5320	0.22	0.22	3.68	3.23		11.00	11.00	1.00	-6.50	Pass
VHT40	MCS0	1	54	5270	0.48	0.46	-0.39	-1.03		11.00	11.00	1.00	-6.50	Pass
VHT40	MCS0	1	62	5310	0.48	0.46	-1.07	-1.77		11.00	11.00	1.00	-6.50	Pass
VHT80	MCS0	1	58	5290	0.85	0.85	-5.61	-6.51		11.00	11.00	1.00	-6.50	Pass
11a	6Mbps	2	52	5260	0.22	0.22			6.98	11.00		1.05		Pass
11a	6Mbps	2	60	5300	0.22	0.22			5.89	11.00		1.05		Pass
11a	6Mbps	2	64	5320	0.22	0.22			6.39	11.00		1.05		Pass
HT20	MCS0	2	52	5260	0.23	0.22			6.51	11.00		1.05		Pass
HT20	MCS0	2	60	5300	0.23	0.22			6.11	11.00		1.05		Pass
HT20	MCS0	2	64	5320	0.23	0.22			6.07	11.00		1.05		Pass
HT40	MCS0	2	54	5270	0.43	0.48			0.77	11.00		1.05		Pass
HT40	MCS0	2	62	5310	0.43	0.48			1.05	11.00		1.05		Pass
VHT20	MCS0	2	52	5260	0.22	0.24			5.45	11.00		1.05		Pass
VHT20	MCS0	2	60	5300	0.22	0.24			5.13	11.00		1.05		Pass
VHT20	MCS0	2	64	5320	0.22	0.24			5.07	11.00		1.05		Pass
VHT40	MCS0	2	54	5270	0.43	0.43			0.23	11.00		1.05		Pass
VHT40	MCS0	2	62	5310	0.43	0.43			0.35	11.00		1.05		Pass
VHT80	MCS0	2	58	5290	0.85	0.85			-4.17	11.00		1.05		Pass

TEST RESULTS DATA
26dB and 99% OBW

Band III															
Mod.	Data Rate	NTX	CH.	Freq. (MHz)	99% Bandwidth (MHz)		26 dB Bandwidth (MHz)		IC 99% Bandwidth Power Limit (dBm)		IC 99% Bandwidth EIRP Limit (dBm)		FCC 26dB Bandwidth Power Limit (dBm)		Note
					Ant 1	Ant 2	Ant 1	Ant 2	Ant 1	Ant 2	Ant 1	Ant 2	Ant 1	Ant 2	
11a	6Mbps	1	100	5500	18.15	17.05	34.60	30.10	23.59	23.32	29.59	29.32	23.98	23.98	
11a	6Mbps	1	116	5580	17.65	17.05	34.90	29.80	23.47	23.32	29.47	29.32	23.98	23.98	
11a	6Mbps	1	140	5700	17.40	17.00	32.20	22.80	23.41	23.30	29.41	29.30	23.98	23.98	
HT20	MCS0	1	100	5500	18.25	17.95	33.10	25.10	23.61	23.54	29.61	29.54	23.98	23.98	
HT20	MCS0	1	116	5580	18.50	17.95	35.60	24.80	23.67	23.54	29.67	29.54	23.98	23.98	
HT20	MCS0	1	140	5700	18.15	18.00	33.00	24.90	23.59	23.55	29.59	29.55	23.98	23.98	
HT40	MCS0	1	102	5510	36.10	36.20	45.72	45.90	23.98	23.98	30.00	30.00	23.98	23.98	
HT40	MCS0	1	110	5550	36.30	36.10	51.84	52.74	23.98	23.98	30.00	30.00	23.98	23.98	
HT40	MCS0	1	134	5670	36.40	36.20	52.92	45.36	23.98	23.98	30.00	30.00	23.98	23.98	
VHT20	MCS0	1	100	5500	18.75	17.95	36.00	24.20	23.73	23.54	29.73	29.54	23.98	23.98	
VHT20	MCS0	1	116	5580	18.50	18.00	35.00	25.40	23.67	23.55	29.67	29.55	23.98	23.98	
VHT20	MCS0	1	140	5700	18.40	18.00	32.30	26.20	23.65	23.55	29.65	29.55	23.98	23.98	
VHT40	MCS0	1	102	5510	36.20	36.10	43.74	42.84	23.98	23.98	30.00	30.00	23.98	23.98	
VHT40	MCS0	1	110	5550	36.30	36.00	49.32	45.72	23.98	23.98	30.00	30.00	23.98	23.98	
VHT40	MCS0	1	134	5670	36.40	36.00	49.32	51.12	23.98	23.98	30.00	30.00	23.98	23.98	
VHT80	MCS0	1	106	5530	75.36	75.00	81.60	81.92	23.98	23.98	30.00	30.00	23.98	23.98	
VHT80	MCS0	1	122	5610	75.60	75.12	106.88	83.20	23.98	23.98	30.00	30.00	23.98	23.98	
11a	6Mbps	2	100	5500	17.55	17.10	34.20	26.70	23.33		29.33		23.98		
11a	6Mbps	2	116	5580	17.80	17.20	36.60	30.00	23.36		29.36		23.98		
11a	6Mbps	2	140	5700	17.35	16.95	31.70	27.00	23.29		29.29		23.98		
HT20	MCS0	2	100	5500	18.60	18.05	36.10	24.40	23.56		29.56		23.98		
HT20	MCS0	2	116	5580	18.75	18.10	37.50	26.50	23.58		29.58		23.98		
HT20	MCS0	2	140	5700	18.25	18.00	34.40	24.80	23.55		29.55		23.98		
HT40	MCS0	2	102	5510	36.20	36.20	44.46	54.18	23.98		30.00		23.98		
HT40	MCS0	2	110	5550	36.30	36.10	48.96	45.72	23.98		30.00		23.98		
HT40	MCS0	2	134	5670	36.40	36.30	50.58	49.32	23.98		30.00		23.98		
VHT20	MCS0	2	100	5500	19.60	18.20	38.40	30.90	23.60		29.60		23.98		
VHT20	MCS0	2	116	5580	18.80	18.10	36.60	28.10	23.58		29.58		23.98		
VHT20	MCS0	2	140	5700	18.30	18.00	31.70	26.40	23.55		29.55		23.98		
VHT40	MCS0	2	102	5510	36.10	36.10	45.90	50.22	23.98		30.00		23.98		
VHT40	MCS0	2	110	5550	36.30	36.10	49.14	57.42	23.98		30.00		23.98		
VHT40	MCS0	2	134	5670	36.20	36.00	53.46	45.72	23.98		30.00		23.98		
VHT80	MCS0	2	106	5530	75.36	75.00	82.56	83.20	23.98		30.00		23.98		
VHT80	MCS0	2	122	5610	75.60	75.24	94.72	84.16	23.98		30.00		23.98		

TEST RESULTS DATA
Average Power Table

FCC Band III														
Mod.	Data Rate	NTX	CH.	Freq. (MHz)	Duty Factor (dB)		Average Conducted Power (dBm)			FCC Conducted Power Limit (dBm)		DG (dBi)		Pass/Fail
					Ant 1	Ant 2	Ant 1	Ant 2	SUM	Ant 1	Ant 2	Ant 1	Ant 2	
11a	6Mbps	1	100	5500	0.22	0.20	16.70	16.10		23.98	23.98	2.00	-6.50	Pass
11a	6Mbps	1	116	5580	0.22	0.20	16.67	16.08		23.98	23.98	2.00	-6.50	Pass
11a	6Mbps	1	140	5700	0.22	0.20	15.68	15.66		23.98	23.98	2.00	-6.50	Pass
HT20	MCS0	1	100	5500	0.22	0.24	16.54	16.23		23.98	23.98	2.00	-6.50	Pass
HT20	MCS0	1	116	5580	0.22	0.24	16.50	16.19		23.98	23.98	2.00	-6.50	Pass
HT20	MCS0	1	140	5700	0.22	0.24	15.77	15.72		23.98	23.98	2.00	-6.50	Pass
HT40	MCS0	1	102	5510	0.43	0.48	13.79	13.26		23.98	23.98	2.00	-6.50	Pass
HT40	MCS0	1	110	5550	0.43	0.48	14.34	14.32		23.98	23.98	2.00	-6.50	Pass
HT40	MCS0	1	134	5670	0.43	0.48	14.60	14.19		23.98	23.98	2.00	-6.50	Pass
VHT20	MCS0	1	100	5500	0.22	0.22	16.51	16.15		23.98	23.98	2.00	-6.50	Pass
VHT20	MCS0	1	116	5580	0.22	0.22	16.46	16.12		23.98	23.98	2.00	-6.50	Pass
VHT20	MCS0	1	140	5700	0.22	0.22	15.68	15.70		23.98	23.98	2.00	-6.50	Pass
VHT40	MCS0	1	102	5510	0.48	0.46	14.06	13.42		23.98	23.98	2.00	-6.50	Pass
VHT40	MCS0	1	110	5550	0.48	0.46	14.39	14.22		23.98	23.98	2.00	-6.50	Pass
VHT40	MCS0	1	134	5670	0.48	0.46	14.60	14.23		23.98	23.98	2.00	-6.50	Pass
VHT80	MCS0	1	106	5530	0.85	0.85	8.54	8.48		23.98	23.98	2.00	-6.50	Pass
VHT80	MCS0	1	122	5610	0.85	0.85	14.76	14.41		23.98	23.98	2.00	-6.50	Pass
11a	6Mbps	2	100	5500	0.22	0.22	15.84	15.32	18.60	23.98		2.00		Pass
11a	6Mbps	2	116	5580	0.22	0.22	15.80	15.28	18.56	23.98		2.00		Pass
11a	6Mbps	2	140	5700	0.22	0.22	14.96	14.81	17.90	23.98		2.00		Pass
HT20	MCS0	2	100	5500	0.23	0.22	15.32	14.67	18.02	23.98		2.00		Pass
HT20	MCS0	2	116	5580	0.23	0.22	15.27	14.63	17.97	23.98		2.00		Pass
HT20	MCS0	2	140	5700	0.23	0.22	14.69	14.48	17.60	23.98		2.00		Pass
HT40	MCS0	2	102	5510	0.43	0.48	13.42	12.76	16.11	23.98		2.00		Pass
HT40	MCS0	2	110	5550	0.43	0.48	13.82	13.55	16.70	23.98		2.00		Pass
HT40	MCS0	2	134	5670	0.43	0.48	13.69	13.31	16.51	23.98		2.00		Pass
VHT20	MCS0	2	100	5500	0.22	0.24	15.76	15.25	18.52	23.98		2.00		Pass
VHT20	MCS0	2	116	5580	0.22	0.24	15.68	15.23	18.47	23.98		2.00		Pass
VHT20	MCS0	2	140	5700	0.22	0.24	14.53	14.42	17.48	23.98		2.00		Pass
VHT40	MCS0	2	102	5510	0.43	0.43	13.36	12.64	16.03	23.98		2.00		Pass
VHT40	MCS0	2	110	5550	0.43	0.43	13.68	13.41	16.56	23.98		2.00		Pass
VHT40	MCS0	2	134	5670	0.43	0.43	13.76	13.35	16.57	23.98		2.00		Pass
VHT80	MCS0	2	106	5530	0.85	0.85	8.63	8.36	11.51	23.98		2.00		Pass
VHT80	MCS0	2	122	5610	0.85	0.85	14.16	13.57	16.89	23.98		2.00		Pass

TEST RESULTS DATA
Power Spectral Density

Band III														
Mod.	Data Rate	NTX	CH.	Freq. (MHz)	Duty Factor (dB)		Average Power Density (dBm/MHz)			Average PSD Limit (dBm/MHz)		DG (dBi)		Pass /Fail
					Ant 1	Ant 2	Ant 1	Ant 2	SUM	Ant 1	Ant 2	Ant 1	Ant 2	
11a	6Mbps	1	100	5500	0.22	0.20	6.04	5.48		11.00	11.00	2.00	-6.50	Pass
11a	6Mbps	1	116	5580	0.22	0.20	6.23	5.76		11.00	11.00	2.00	-6.50	Pass
11a	6Mbps	1	140	5700	0.22	0.20	3.91	4.04		11.00	11.00	2.00	-6.50	Pass
HT20	MCS0	1	100	5500	0.22	0.24	5.94	5.52		11.00	11.00	2.00	-6.50	Pass
HT20	MCS0	1	116	5580	0.22	0.24	6.17	5.52		11.00	11.00	2.00	-6.50	Pass
HT20	MCS0	1	140	5700	0.22	0.24	3.84	3.88		11.00	11.00	2.00	-6.50	Pass
HT40	MCS0	1	102	5510	0.43	0.48	0.64	0.16		11.00	11.00	2.00	-6.50	Pass
HT40	MCS0	1	110	5550	0.43	0.48	0.83	0.74		11.00	11.00	2.00	-6.50	Pass
HT40	MCS0	1	134	5670	0.43	0.48	-0.26	-0.64		11.00	11.00	2.00	-6.50	Pass
VHT20	MCS0	1	100	5500	0.22	0.22	4.83	4.35		11.00	11.00	2.00	-6.50	Pass
VHT20	MCS0	1	116	5580	0.22	0.22	5.08	4.67		11.00	11.00	2.00	-6.50	Pass
VHT20	MCS0	1	140	5700	0.22	0.22	3.30	3.34		11.00	11.00	2.00	-6.50	Pass
VHT40	MCS0	1	102	5510	0.48	0.46	-0.46	-0.91		11.00	11.00	2.00	-6.50	Pass
VHT40	MCS0	1	110	5550	0.48	0.46	0.01	-0.18		11.00	11.00	2.00	-6.50	Pass
VHT40	MCS0	1	134	5670	0.48	0.46	-0.44	-0.69		11.00	11.00	2.00	-6.50	Pass
VHT80	MCS0	1	106	5530	0.85	0.85	-8.55	-9.09		11.00	11.00	2.00	-6.50	Pass
VHT80	MCS0	1	122	5610	0.85	0.85	-3.00	-2.84		11.00	11.00	2.00	-6.50	Pass
11a	6Mbps	2	100	5500	0.22	0.22			7.81	11.00		1.76	Pass	
11a	6Mbps	2	116	5580	0.22	0.22			7.59	11.00		1.76	Pass	
11a	6Mbps	2	140	5700	0.22	0.22			5.52	11.00		1.76	Pass	
HT20	MCS0	2	100	5500	0.23	0.22			7.18	11.00		1.76	Pass	
HT20	MCS0	2	116	5580	0.23	0.22			7.81	11.00		1.76	Pass	
HT20	MCS0	2	140	5700	0.23	0.22			6.08	11.00		1.76	Pass	
HT40	MCS0	2	102	5510	0.43	0.48			0.32	11.00		1.76	Pass	
HT40	MCS0	2	110	5550	0.43	0.48			1.67	11.00		1.76	Pass	
HT40	MCS0	2	134	5670	0.43	0.48			-0.31	11.00		1.76	Pass	
VHT20	MCS0	2	100	5500	0.22	0.24			6.27	11.00		1.76	Pass	
VHT20	MCS0	2	116	5580	0.22	0.24			6.47	11.00		1.76	Pass	
VHT20	MCS0	2	140	5700	0.22	0.24			5.09	11.00		1.76	Pass	
VHT40	MCS0	2	102	5510	0.43	0.43			-0.42	11.00		1.76	Pass	
VHT40	MCS0	2	110	5550	0.43	0.43			0.93	11.00		1.76	Pass	
VHT40	MCS0	2	134	5670	0.43	0.43			-0.45	11.00		1.76	Pass	
VHT80	MCS0	2	106	5530	0.85	0.85			-8.86	11.00		1.76	Pass	
VHT80	MCS0	2	122	5610	0.85	0.85			-3.32	11.00		1.76	Pass	

TEST RESULTS DATA
26dB and 99% OBW

Straddle Channel															
Mod.	Data Rate	NTX	CH.	Freq. (MHz)	99% Bandwidth (MHz)		Emission Bandwidth (MHz)		IC 99% Bandwidth Power Limit (dBm)		IC 99% Bandwidth EIRP Limit (dBm)		FCC 26dB Bandwidth Power Limit (dBm)		Note
					Ant 1	Ant 2	Ant 1	Ant 2	Ant 1	Ant 2	Ant 1	Ant 2	Ant 1	Ant 2	
11a	6Mbps	1	144	5720	17.25	17.15	22.20	20.10	-	-	-	-	-	-	
				NII-2C	13.60	13.65	19.60	17.50	22.34	22.35	28.34	28.35	23.92	23.43	
				NII-3	3.65	3.50	2.60	2.60	22.62	22.44	28.62	28.44	-	-	
HT20	MCS0	1	144	5720	18.35	22.90	18.15	21.50	-	-	-	-	-	-	
				NII-2C	14.10	20.30	14.10	18.90	22.49	23.98	28.49	30.00	22.49	23.76	
				NII-3	4.25	2.60	4.05	2.60	23.28	21.15	29.28	27.15	-	-	
HT40	MCS0	1	142	5710	36.40	36.20	46.58	41.72	-	-	-	-	-	-	
				NII-2C	33.20	33.20	43.98	39.12	23.98	23.98	30.00	30.00	23.98	23.98	
				NII-3	3.20	3.00	2.60	2.60	22.05	21.77	28.05	27.77	-	-	
VHT20	MCS0	1	144	5720	18.30	18.10	21.40	19.30	-	-	-	-	-	-	
				NII-2C	14.10	14.05	18.80	16.70	22.49	22.48	28.49	28.48	23.74	23.23	
				NII-3	4.20	4.05	2.60	2.60	23.23	23.07	29.23	29.07	-	-	
VHT40	MCS0	1	142	5710	36.40	36.20	45.68	40.82	-	-	-	-	-	-	
				NII-2C	33.20	33.20	43.08	38.22	23.98	23.98	30.00	30.00	23.98	23.98	
				NII-3	3.20	3.00	2.60	2.60	22.05	21.77	28.05	27.77	-	-	
VHT80	MCS0	1	138	5690	75.60	75.12	88.48	79.20	-	-	-	-	-	-	
				NII-2C	72.92	72.68	85.88	76.60	23.98	23.98	30.00	30.00	23.98	23.98	
				NII-3	2.68	2.44	2.60	2.60	21.28	20.87	27.28	26.87	-	-	
11a	6Mbps	2	144	5720	18.25	17.10	22.54	20.14	-	-	-	-	-	-	
				NII-2C	13.95	13.55	19.9	17.5	22.32	-	28.32	-	23.43	-	
				NII-3	4.3	3.55	2.64	2.64	22.50	-	28.50	-	15.22	-	
HT20	MCS0	2	144	5720	18.25	18.15	24.84	20.44	-	-	-	-	-	-	
				NII-2C	14.15	14.05	22.2	17.8	22.48	-	28.48	-	23.50	-	
				NII-3	4.1	4.1	2.64	2.64	23.13	-	29.13	-	15.22	-	
HT40	MCS0	2	142	5710	36.40	36.20	43.88	46.58	-	-	-	-	-	-	
				NII-2C	33.3	33.2	41.28	43.98	23.98	-	30.00	-	23.98	-	
				NII-3	3.1	3	2.6	2.6	21.77	-	27.77	-	15.15	-	
VHT20	MCS0	2	144	5720	18.65	18.10	22.94	20.64	-	-	-	-	-	-	
				NII-2C	14.2	14.05	20.3	18	22.48	-	28.48	-	23.55	-	
				NII-3	4.45	4.05	2.64	2.64	23.07	-	29.07	-	15.22	-	
VHT40	MCS0	2	142	5710	36.30	36.20	48.20	39.38	-	-	-	-	-	-	
				NII-2C	33.2	33.2	45.6	36.78	23.98	-	30.00	-	23.98	-	
				NII-3	3.1	3	2.6	2.6	21.77	-	27.77	-	15.15	-	
VHT80	MCS0	2	138	5690	75.60	75.24	86.24	92.00	-	-	-	-	-	-	
				NII-2C	72.92	72.8	83.64	89.4	23.98	-	30.00	-	23.98	-	
				NII-3	2.68	2.44	2.6	2.6	20.87	-	26.87	-	15.15	-	

TEST RESULTS DATA
Average Power Table

FCC Straddle Channel														
Mod.	Data Rate	NTX	CH.	Freq. (MHz)	Duty Factor (dB)		Average Conducted Power (dBm)			FCC Conducted Power Limit (dBm)		DG (dBi)		Pass/Fail
					Ant 1	Ant 2	Ant 1	Ant 2	SUM	Ant 1	Ant 2	Ant 1	Ant 2	
11a	6Mbps	1	144	5720	0.22	0.20	15.13	14.63		-	-	2.00	-6.50	-
				NII-2C	0.22	0.20	14.43	13.93		23.92	23.43	2.00	-6.50	Pass
				NII-3	0.22	0.20	6.88	6.36		-	-	2.00	-6.50	Pass
HT20	MCS0	1	144	5720	0.22	0.24	14.64	14.55		-	-	2.00	-6.50	-
				NII-2C	0.22	0.24	13.86	13.79		22.49	23.76	2.00	-6.50	Pass
				NII-3	0.22	0.24	6.78	6.62		-	-	2.00	-6.50	Pass
HT40	MCS0	1	142	5710	0.43	0.48	12.79	12.60		-	-	2.00	-6.50	-
				NII-2C	0.43	0.48	12.53	12.38		23.98	23.98	2.00	-6.50	Pass
				NII-3	0.43	0.48	0.36	-0.49		-	-	2.00	-6.50	Pass
VHT20	MCS0	1	144	5720	0.22	0.22	14.71	14.35		-	-	2.00	-6.50	-
				NII-2C	0.22	0.22	13.92	13.59		23.74	23.23	2.00	-6.50	Pass
				NII-3	0.22	0.22	6.89	6.43		-	-	2.00	-6.50	Pass
VHT40	MCS0	1	142	5710	0.48	0.46	12.82	12.77		-	-	2.00	-6.50	-
				NII-2C	0.48	0.46	12.58	12.55		23.98	23.98	2.00	-6.50	Pass
				NII-3	0.48	0.46	0.08	-0.27		-	-	2.00	-6.50	Pass
VHT80	MCS0	1	138	5690	0.85	0.85	13.62	13.37		-	-	2.00	-6.50	-
				NII-2C	0.85	0.85	13.54	13.30		23.98	23.98	2.00	-6.50	Pass
				NII-3	0.85	0.85	-3.72	-4.73		-	-	2.00	-6.50	Pass
11a	6Mbps	2	144	5720	0.22	0.22	13.88	13.78	16.84		-		2.00	-
				NII-2C	0.22	0.22	13.13	13.04	16.10		23.43		2.00	Pass
				NII-3	0.22	0.22	5.86	5.73	8.81		15.22		2.00	Pass
HT20	MCS0	2	144	5720	0.23	0.22	13.94	13.61	16.79		-		2.00	-
				NII-2C	0.23	0.22	13.15	12.84	16.01		23.50		2.00	Pass
				NII-3	0.23	0.22	6.12	5.73	8.94		15.22		2.00	Pass
HT40	MCS0	2	142	5710	0.43	0.48	12.23	11.93	15.09		-		2.00	-
				NII-2C	0.43	0.48	11.99	11.70	14.86		23.98		2.00	Pass
				NII-3	0.43	0.48	-0.50	-1.00	2.27		15.15		2.00	Pass
VHT20	MCS0	2	144	5720	0.22	0.24	13.42	13.26	16.35		-		2.00	-
				NII-2C	0.22	0.24	12.60	12.47	15.55		23.55		2.00	Pass
				NII-3	0.22	0.24	5.77	5.47	8.63		15.22		2.00	Pass
VHT40	MCS0	2	142	5710	0.43	0.43	12.04	12.00	15.03		-		2.00	-
				NII-2C	0.43	0.43	11.79	11.76	14.79		23.98		2.00	Pass
				NII-3	0.43	0.43	-0.49	-0.77	2.38		15.15		2.00	Pass
VHT80	MCS0	2	138	5690	0.85	0.85	12.99	12.42	15.72		-		2.00	-
				NII-2C	0.85	0.85	12.91	12.34	15.64		23.98		2.00	Pass
				NII-3	0.85	0.85	-4.26	-5.21	-1.70		15.15		2.00	Pass

TEST RESULTS DATA
Power Spectral Density

Straddle Channel														
Mod.	Data Rate	NTX	CH.	Freq. (MHz)	Duty Factor (dB)		Average Power Density (dBm/MHz)			Average PSD Limit (dBm/MHz)		DG (dBi)		Pass /Fail
					Ant 1	Ant 2	Ant 1	Ant 2	SUM	Ant 1	Ant 2	Ant 1	Ant 2	
11a	6Mbps	1	144	NII-2C	0.22	0.20	4.09	3.28		11.00	11.00	2.00	-6.50	Pass
				NII-3	0.22	0.20	4.09	3.28		30.00	30.00	2.00	-6.50	Pass
HT20	MCS0	1	144	NII-2C	0.22	0.24	3.52	3.38		11.00	11.00	2.00	-6.50	Pass
				NII-3	0.22	0.24	3.52	3.38		30.00	30.00	2.00	-6.50	Pass
HT40	MCS0	1	142	NII-2C	0.43	0.48	-1.17	-1.11		11.00	11.00	2.00	-6.50	Pass
				NII-3	0.43	0.48	-1.17	-1.11		30.00	30.00	2.00	-6.50	Pass
VHT20	MCS0	1	144	NII-2C	0.22	0.22	3.61	2.98		11.00	11.00	2.00	-6.50	Pass
				NII-3	0.22	0.22	3.61	2.98		30.00	30.00	2.00	-6.50	Pass
VHT40	MCS0	1	142	NII-2C	0.48	0.46	-1.50	-1.37		11.00	11.00	2.00	-6.50	Pass
				NII-3	0.48	0.46	-1.50	-1.37		30.00	30.00	2.00	-6.50	Pass
VHT80	MCS0	1	138	NII-2C	0.85	0.85	-3.87	-4.04		11.00	11.00	2.00	-6.50	Pass
				NII-3	0.85	0.85	-3.87	-4.04		30.00	30.00	2.00	-6.50	Pass
11a	6Mbps	2	144	NII-2C	0.22	0.22				5.22	11.00	1.76		Pass
				NII-3	0.22	0.22				5.22	30.00	1.76		Pass
HT20	MCS0	2	144	NII-2C	0.23	0.22				4.63	11.00	1.76		Pass
				NII-3	0.23	0.22				4.63	30.00	1.76		Pass
HT40	MCS0	2	142	NII-2C	0.43	0.48			-0.64	11.00	1.76		Pass	
				NII-3	0.43	0.48			-0.64	30.00	1.76		Pass	
VHT20	MCS0	2	144	NII-2C	0.22	0.24			4.92	11.00	1.76		Pass	
				NII-3	0.22	0.24			4.92	30.00	1.76		Pass	
VHT40	MCS0	2	142	NII-2C	0.43	0.43			-0.59	11.00	1.76		Pass	
				NII-3	0.43	0.43			-0.59	30.00	1.76		Pass	
VHT80	MCS0	2	138	NII-2C	0.85	0.85			-4.09	11.00	1.76		Pass	
				NII-3	0.85	0.85			-4.09	30.00	1.76		Pass	

TEST RESULTS DATA
Frequency Stability

Band I										
Mod.	Data Rate	NTX	CH.	Freq. (MHz)	Center Frequency (MHz)	Frequency Deviation (MHz)	Frequency Stability (ppm)	Temperature (°C)	Voltage (V)	Note
11a	6Mbps	1	36	5180	5180.000	0.000	0.00	20	3.4	
11a	6Mbps	1	36	5180	5180.000	0.000	0.00	20	4.35	
11a	6Mbps	1	36	5180	5180.000	0.000	0.00	20	3.8	
11a	6Mbps	1	36	5180	5180.000	0.000	0.00	-30	3.8	
11a	6Mbps	1	36	5180	5179.975	-0.025	-4.83	50	3.8	

Band II										
Mod.	Data Rate	NTX	CH.	Freq. (MHz)	Center Frequency (MHz)	Frequency Deviation (MHz)	Frequency Stability (ppm)	Temperature (°C)	Voltage (V)	Note
11a	6Mbps	1	64	5320	5320.000	0.000	0.00	20	3.4	
11a	6Mbps	1	64	5320	5320.000	0.000	0.00	20	4.35	
11a	6Mbps	1	64	5320	5320.000	0.000	0.00	20	3.8	
11a	6Mbps	1	64	5320	5320.025	0.025	4.70	-30	3.8	
11a	6Mbps	1	64	5320	5320.050	0.050	9.40	50	3.8	

Band III										
Mod.	Data Rate	NTX	CH.	Freq. (MHz)	Center Frequency (MHz)	Frequency Deviation (MHz)	Frequency Stability (ppm)	Temperature (°C)	Voltage (V)	Note
11a	6Mbps	1	100	5500	5500.025	0.025	4.55	20	3.4	
11a	6Mbps	1	100	5500	5500.050	0.050	9.09	20	4.35	
11a	6Mbps	1	100	5500	5500.000	0.000	0.00	20	3.8	
11a	6Mbps	1	100	5500	5500.000	0.000	0.00	-30	3.8	
11a	6Mbps	1	100	5500	5500.000	0.000	0.00	50	3.8	



Appendix B. Radiated Spurious Emission

Test Engineer :	J.C. Liang, Bill Chang, and Ken Wu	Temperature :	19~21°C
		Relative Humidity :	50~55%

Band 1 - 5150~5250MHz

WIFI 802.11a (Band Edge @ 3m)

WIFI Ant. 1+2	Note	Frequency (MHz)	Level (dBμV/m)	Over Limit (dB)	Limit Line (dBμV/m)	Read Level (dBμV)	Antenna Factor (dB/m)	Cable Loss (dB)	Preamp Factor (dB)	Ant Pos (cm)	Table Pos (deg)	Peak Avg. (P/A)	Pol. (H/V)	
802.11a CH 36 5180MHz		5150	56.41	-17.59	74	48.07	31.58	10.23	33.47	102	121	P	H	
		5149.7	48.12	-5.88	54	39.78	31.58	10.23	33.47	102	121	A	H	
	*	5180	102.91	-	-	94.53	31.62	10.23	33.47	102	121	P	H	
	*	5180	95.47	-	-	87.09	31.62	10.23	33.47	102	121	A	H	
													H	
														H
			5150	56.95	-17.05	74	48.61	31.58	10.23	33.47	354	100	P	V
			5150	48.92	-5.08	54	40.58	31.58	10.23	33.47	354	100	A	V
	*		5180	105.02	-	-	96.64	31.62	10.23	33.47	354	100	P	V
	*		5180	98.63	-	-	90.25	31.62	10.23	33.47	354	100	A	V
														V
														V
802.11a CH 44 5220MHz		5040.8	48.79	-25.21	74	40.6	31.46	10.2	33.47	105	174	P	H	
		5085.35	39.78	-14.22	54	31.54	31.5	10.21	33.47	105	174	A	H	
	*	5220	100.75	-	-	92.32	31.66	10.24	33.47	105	174	P	H	
	*	5220	95.98	-	-	87.55	31.66	10.24	33.47	105	174	A	H	
			5448.67	49.54	-24.46	74	40.24	31.94	10.84	33.48	105	174	P	H
			5458.24	39.32	-14.68	54	30.02	31.94	10.84	33.48	105	174	A	H
			5003.75	48.06	-25.94	74	39.92	31.42	10.19	33.47	349	99	P	V
			5106.2	39.71	-14.29	54	31.42	31.54	10.22	33.47	349	99	A	V
	*		5220	103.59	-	-	95.16	31.66	10.24	33.47	349	99	P	V
	*		5220	98.47	-	-	90.04	31.66	10.24	33.47	349	99	A	V
			5381.46	47.74	-26.26	74	38.49	31.86	10.87	33.48	349	99	P	V
			5451.75	39.29	-14.71	54	29.99	31.94	10.84	33.48	349	99	A	V



802.11a CH 48 5240MHz		5064.5	48.59	-25.41	74	40.37	31.48	10.21	33.47	109	195	P	H
		5113.85	39.71	-14.29	54	31.42	31.54	10.22	33.47	109	195	A	H
	*	5240	102.09	-	-	93.51	31.68	10.37	33.47	109	195	P	H
	*	5240	96.16	-	-	87.58	31.68	10.37	33.47	109	195	A	H
		5407.53	48.11	-25.89	74	38.84	31.88	10.87	33.48	109	195	P	H
		5444.38	39.23	-14.77	54	29.95	31.92	10.84	33.48	109	195	A	H
		5116.7	49.35	-24.65	74	41.06	31.54	10.22	33.47	365	97	P	V
		5106.95	39.77	-14.23	54	31.48	31.54	10.22	33.47	365	97	A	V
	*	5240	106.17	-	-	97.59	31.68	10.37	33.47	365	97	P	V
	*	5240	98.8	-	-	90.22	31.68	10.37	33.47	365	97	A	V
		5354.4	48.95	-25.05	74	39.86	31.82	10.75	33.48	365	97	P	V
		5454.72	39.45	-14.55	54	30.15	31.94	10.84	33.48	365	97	A	V
Remark	1. No other spurious found. 2. All results are PASS against Peak and Average limit line.												



Band 1 5150~5250MHz

WIFI 802.11a (Harmonic @ 3m)

WIFI Ant. 1+2	Note	Frequency (MHz)	Level (dBμV/m)	Over Limit (dB)	Limit Line (dBμV/m)	Read Level (dBμV)	Antenna Factor (dB/m)	Cable Loss (dB)	Preamp Factor (dB)	Ant Pos (cm)	Table Pos (deg)	Peak Avg. (P/A)	Pol. (H/V)
802.11a CH 36 5180MHz		10360	47.45	-26.55	74	60.3	39.79	14.86	67.5	100	0	P	H
		15540	40.19	-33.81	74	49.09	38.6	17.89	65.39	100	0	P	H
													H
													H
		10360	47.53	-26.47	74	60.38	39.79	14.86	67.5	100	0	P	V
		15540	44.86	-29.14	74	53.76	38.6	17.89	65.39	100	0	P	V
													V
													V
802.11a CH 44 5220MHz		10440	47.43	-26.57	74	60.13	39.89	14.91	67.5	100	0	P	H
		15660	40.27	-33.73	74	49.47	38.23	17.94	65.37	100	0	P	H
													H
													H
		10440	45.88	-28.12	74	58.58	39.89	14.91	67.5	100	0	P	V
		15660	40.63	-33.37	74	49.83	38.23	17.94	65.37	100	0	P	V
													V
													V
802.11a CH 48 5240MHz		10480	46.68	-27.32	74	59.27	39.97	14.94	67.5	100	0	P	H
		15720	40.61	-33.39	74	49.97	38.03	17.97	65.36	100	0	P	H
													H
													H
		10480	46.24	-27.76	74	58.83	39.97	14.94	67.5	100	0	P	V
		15720	41.34	-32.66	74	50.7	38.03	17.97	65.36	100	0	P	V
													V
													V
Remark	1. No other spurious found. 2. All results are PASS against Peak and Average limit line.												



Band 1 5150~5250MHz

WIFI 802.11n HT20 (Band Edge @ 3m)

WIFI Ant. 1+2	Note	Frequency (MHz)	Level (dBμV/m)	Over Limit (dB)	Limit Line (dBμV/m)	Read Level (dBμV)	Antenna Factor (dB/m)	Cable Loss (dB)	Preamp Factor (dB)	Ant Pos (cm)	Table Pos (deg)	Peak Avg. (P/A)	Pol. (H/V)	
802.11n HT20 CH 36 5180MHz		5149.85	55.37	-18.63	74	47.03	31.58	10.23	33.47	100	116	P	H	
		5149.85	48.24	-5.76	54	39.9	31.58	10.23	33.47	100	116	A	H	
	*	5180	103.23	-	-	94.85	31.62	10.23	33.47	100	116	P	H	
	*	5180	95.05	-	-	86.67	31.62	10.23	33.47	100	116	A	H	
													H	
														H
			5149.55	54.1	-19.9	74	45.76	31.58	10.23	33.47	378	97	P	V
			5149.4	49.1	-4.9	54	40.76	31.58	10.23	33.47	378	97	A	V
		*	5180	103.53	-	-	95.15	31.62	10.23	33.47	378	97	P	V
		*	5180	97.73	-	-	89.35	31.62	10.23	33.47	378	97	A	V
													V	
													V	
802.11n HT20 CH 44 5220MHz		5067.95	48.81	-25.19	74	40.59	31.48	10.21	33.47	100	122	P	H	
		5073.65	39.8	-14.2	54	31.56	31.5	10.21	33.47	100	122	A	H	
	*	5220	104.18	-	-	95.75	31.66	10.24	33.47	100	122	P	H	
	*	5220	95.94	-	-	87.51	31.66	10.24	33.47	100	122	A	H	
			5384.43	48.83	-25.17	74	39.58	31.86	10.87	33.48	100	122	P	H
			5441.3	39.29	-14.71	54	30.01	31.92	10.84	33.48	100	122	A	H
			5138.45	48.26	-25.74	74	39.95	31.56	10.22	33.47	354	101	P	V
			5093.75	39.68	-14.32	54	31.42	31.52	10.21	33.47	354	101	A	V
		*	5220	106.11	-	-	97.68	31.66	10.24	33.47	354	101	P	V
		*	5220	99.11	-	-	90.68	31.66	10.24	33.47	354	101	A	V
		5418.2	47.36	-26.64	74	38.07	31.9	10.87	33.48	354	101	P	V	
		5453.95	39.36	-14.64	54	30.06	31.94	10.84	33.48	354	101	A	V	



802.11n HT20 CH 48 5240MHz		5009.9	49.68	-24.32	74	41.54	31.42	10.19	33.47	100	117	P	H
		5088.35	39.64	-14.36	54	31.4	31.5	10.21	33.47	100	117	A	H
	*	5240	103.38	-	-	94.8	31.68	10.37	33.47	100	117	P	H
	*	5240	95.47	-	-	86.89	31.68	10.37	33.47	100	117	A	H
		5456.37	48.36	-25.64	74	39.06	31.94	10.84	33.48	100	117	P	H
		5452.96	39.32	-14.68	54	30.02	31.94	10.84	33.48	100	117	A	H
		5074.7	48.57	-25.43	74	40.33	31.5	10.21	33.47	367	102	P	V
		5094.65	39.63	-14.37	54	31.37	31.52	10.21	33.47	367	102	A	V
	*	5240	106.87	-	-	98.29	31.68	10.37	33.47	367	102	P	V
	*	5240	98.97	-	-	90.39	31.68	10.37	33.47	367	102	A	V
		5425.46	48.07	-25.93	74	38.81	31.9	10.84	33.48	367	102	P	V
		5420.18	39.55	-14.45	54	30.29	31.9	10.84	33.48	367	102	A	V
Remark	1. No other spurious found. 2. All results are PASS against Peak and Average limit line.												



Band 1 5150~5250MHz

WIFI 802.11n HT20 (Harmonic @ 3m)

WIFI Ant. 1+2	Note	Frequency (MHz)	Level (dBμV/m)	Over Limit (dB)	Limit Line (dBμV/m)	Read Level (dBμV)	Antenna Factor (dB/m)	Cable Loss (dB)	Preamp Factor (dB)	Ant Pos (cm)	Table Pos (deg)	Peak Avg. (P/A)	Pol. (H/V)
802.11n HT20 CH 36 5180MHz		10360	47.49	-26.51	74	60.34	39.79	14.86	67.5	100	0	P	H
		15540	40.71	-33.29	74	49.61	38.6	17.89	65.39	100	0	P	H
													H
													H
		10360	46.79	-27.21	74	59.64	39.79	14.86	67.5	100	0	P	V
		15540	44.44	-29.56	74	53.34	38.6	17.89	65.39	100	0	P	V
													V
802.11n HT20 CH 44 5220MHz		10440	46.7	-27.3	74	59.4	39.89	14.91	67.5	100	0	P	H
		15660	40.43	-33.57	74	49.63	38.23	17.94	65.37	100	0	P	H
													H
													H
		10440	45.98	-28.02	74	58.68	39.89	14.91	67.5	100	0	P	V
		15660	41.62	-32.38	74	50.82	38.23	17.94	65.37	100	0	P	V
													V
802.11n HT20 CH 48 5240MHz		10480	46.61	-27.39	74	59.2	39.97	14.94	67.5	100	0	P	H
		15720	40.48	-33.52	74	49.84	38.03	17.97	65.36	100	0	P	H
													H
													H
		10480	45.41	-28.59	74	58	39.97	14.94	67.5	100	0	P	V
		15720	45.23	-28.77	74	54.59	38.03	17.97	65.36	100	0	P	V
													V
Remark	1. No other spurious found.												
	2. All results are PASS against Peak and Average limit line.												



Band 1 5150~5250MHz

WIFI 802.11n HT40 (Band Edge @ 3m)

WIFI Ant. 1+2	Note	Frequency (MHz)	Level (dBμV/m)	Over Limit (dB)	Limit Line (dBμV/m)	Read Level (dBμV)	Antenna Factor (dB/m)	Cable Loss (dB)	Preamp Factor (dB)	Ant Pos (cm)	Table Pos (deg)	Peak Avg. (P/A)	Pol. (H/V)
802.11n HT40 CH 38 5190MHz		5148.35	57.67	-16.33	74	49.33	31.58	10.23	33.47	100	117	P	H
		5149.85	52.46	-1.54	54	44.12	31.58	10.23	33.47	100	117	A	H
	*	5190	98.82	-	-	90.43	31.62	10.24	33.47	100	117	P	H
	*	5190	90.63	-	-	82.24	31.62	10.24	33.47	100	117	A	H
		5361.33	48.3	-25.7	74	39.19	31.84	10.75	33.48	100	117	P	H
		5406.98	40.09	-13.91	54	30.82	31.88	10.87	33.48	100	117	A	H
		5149.7	59.37	-14.63	74	51.03	31.58	10.23	33.47	374	99	P	V
		5149.55	52.47	-1.53	54	44.13	31.58	10.23	33.47	374	99	A	V
	*	5190	101.26	-	-	92.87	31.62	10.24	33.47	374	99	P	V
	*	5190	94.07	-	-	85.68	31.62	10.24	33.47	374	99	A	V
		5382.78	49.12	-24.88	74	39.87	31.86	10.87	33.48	374	99	P	V
		5406.54	39.94	-14.06	54	30.67	31.88	10.87	33.48	374	99	A	V
802.11n HT40 CH 46 5230MHz		5118.2	48.61	-25.39	74	40.32	31.54	10.22	33.47	100	116	P	H
		5143.4	40.78	-13.22	54	32.44	31.58	10.23	33.47	100	116	A	H
	*	5230	99.86	-	-	91.28	31.68	10.37	33.47	100	116	P	H
	*	5230	91.94	-	-	83.36	31.68	10.37	33.47	100	116	A	H
		5363.31	48.27	-25.73	74	39.16	31.84	10.75	33.48	100	116	P	H
		5445.15	39.94	-14.06	54	30.66	31.92	10.84	33.48	100	116	A	H
		5120.9	48.69	-25.31	74	40.4	31.54	10.22	33.47	395	95	P	V
		5147.3	40.58	-13.42	54	32.24	31.58	10.23	33.47	395	95	A	V
	*	5230	102.34	-	-	93.76	31.68	10.37	33.47	395	95	P	V
	*	5230	94.67	-	-	86.09	31.68	10.37	33.47	395	95	A	V
	5388.39	50.7	-23.3	74	41.45	31.86	10.87	33.48	395	95	P	V	
	5446.58	40.2	-13.8	54	30.9	31.94	10.84	33.48	395	95	A	V	
Remark	1. No other spurious found. 2. All results are PASS against Peak and Average limit line.												



Band 1 5150~5250MHz

WIFI 802.11n HT40 (Harmonic @ 3m)

WIFI Ant. 1+2	Note	Frequency (MHz)	Level (dBμV/m)	Over Limit (dB)	Limit Line (dBμV/m)	Read Level (dBμV)	Antenna Factor (dB/m)	Cable Loss (dB)	Preamp Factor (dB)	Ant Pos (cm)	Table Pos (deg)	Peak Avg. (P/A)	Pol. (H/V)
802.11n HT40 CH 38 5190MHz		10380	46.44	-27.56	74	59.27	39.81	14.86	67.5	100	0	P	H
		15570	39.52	-34.48	74	48.52	38.49	17.9	65.39	100	0	P	H
													H
													H
		10380	46.33	-27.67	74	59.16	39.81	14.86	67.5	100	0	P	V
		15570	39.93	-34.07	74	48.93	38.49	17.9	65.39	100	0	P	V
													V
802.11n HT40 CH 46 5230MHz		10460	45.49	-28.51	74	58.16	39.92	14.91	67.5	100	0	P	H
		15690	39.19	-34.81	74	48.46	38.13	17.96	65.36	100	0	P	H
													H
													H
		10460	44.42	-29.58	74	57.09	39.92	14.91	67.5	100	0	P	V
		15690	39.61	-34.39	74	48.88	38.13	17.96	65.36	100	0	P	V
													V
Remark	1. No other spurious found.												
	2. All results are PASS against Peak and Average limit line.												



Band 1 5150~5250MHz

WIFI 802.11ac VHT20 (Band Edge @ 3m)

WIFI Ant. 1+2	Note	Frequency (MHz)	Level (dBμV/m)	Over Limit (dB)	Limit Line (dBμV/m)	Read Level (dBμV)	Antenna Factor (dB/m)	Cable Loss (dB)	Preamp Factor (dB)	Ant Pos (cm)	Table Pos (deg)	Peak Avg. (P/A)	Pol. (H/V)	
802.11ac VHT20 CH 36 5180MHz		5148.05	55.54	-18.46	74	47.2	31.58	10.23	33.47	100	116	P	H	
		5149.85	51.01	-2.99	54	42.67	31.58	10.23	33.47	100	116	A	H	
	*	5180	104.77	-	-	96.39	31.62	10.23	33.47	100	116	P	H	
	*	5180	96.77	-	-	88.39	31.62	10.23	33.47	100	116	A	H	
													H	
														H
			5145.8	59.97	-14.03	74	51.63	31.58	10.23	33.47	359	100	P	V
			5150	53.52	-0.48	54	45.18	31.58	10.23	33.47	359	100	A	V
		*	5180	106.42	-	-	98.04	31.62	10.23	33.47	359	100	P	V
		*	5180	98.96	-	-	90.58	31.62	10.23	33.47	359	100	A	V
													V	
													V	
802.11ac VHT20 CH 44 5220MHz		5070.95	48.37	-25.63	74	40.15	31.48	10.21	33.47	100	122	P	H	
		5095.85	39.67	-14.33	54	31.41	31.52	10.21	33.47	100	122	A	H	
	*	5220	103.92	-	-	95.49	31.66	10.24	33.47	100	122	P	H	
	*	5220	96.1	-	-	87.67	31.66	10.24	33.47	100	122	A	H	
			5449.66	48.77	-25.23	74	39.47	31.94	10.84	33.48	100	122	P	H
			5444.93	39.24	-14.76	54	29.96	31.92	10.84	33.48	100	122	A	H
			5142.65	48.35	-25.65	74	40.01	31.58	10.23	33.47	354	102	P	V
			5089.1	39.86	-14.14	54	31.6	31.52	10.21	33.47	354	102	A	V
		*	5220	106.8	-	-	98.37	31.66	10.24	33.47	354	102	P	V
		*	5220	99.12	-	-	90.69	31.66	10.24	33.47	354	102	A	V
		5394.55	48.81	-25.19	74	39.54	31.88	10.87	33.48	354	102	P	V	
		5454.39	39.28	-14.72	54	29.98	31.94	10.84	33.48	354	102	A	V	



802.11ac VHT20 CH 48 5240MHz		5144.45	48.58	-25.42	74	40.24	31.58	10.23	33.47	109	195	P	H
		5098.7	39.66	-14.34	54	31.4	31.52	10.21	33.47	109	195	P	H
	*	5240	103.03	-	-	94.45	31.68	10.37	33.47	100	116	P	H
	*	5240	95.55	-	-	86.97	31.68	10.37	33.47	100	116	A	H
		5433.93	48.25	-25.75	74	38.97	31.92	10.84	33.48	100	116	P	H
		5455.05	39.32	-14.68	54	30.02	31.94	10.84	33.48	100	116	A	H
		5033.9	48.4	-25.6	74	40.23	31.44	10.2	33.47	365	97	P	V
		5080.85	39.62	-14.38	54	31.38	31.5	10.21	33.47	365	97	P	V
	*	5240	106.79	-	-	98.21	31.68	10.37	33.47	367	98	P	V
	*	5240	98.76	-	-	90.18	31.68	10.37	33.47	367	98	A	V
		5451.09	47.96	-26.04	74	38.66	31.94	10.84	33.48	367	98	P	V
		5452.85	39.46	-14.54	54	30.16	31.94	10.84	33.48	367	98	A	V
Remark	1. No other spurious found. 2. All results are PASS against Peak and Average limit line.												



Band 1 5150~5250MHz

WIFI 802.11ac VHT20 (Harmonic @ 3m)

WIFI Ant. 1+2	Note	Frequency (MHz)	Level (dBμV/m)	Over Limit (dB)	Limit Line (dBμV/m)	Read Level (dBμV)	Antenna Factor (dB/m)	Cable Loss (dB)	Preamp Factor (dB)	Ant Pos (cm)	Table Pos (deg)	Peak Avg. (P/A)	Pol. (H/V)	
802.11ac VHT20 CH 36 5180MHz		10360	47.29	-26.71	74	60.14	39.79	14.86	67.5	100	0	P	H	
		15540	40.34	-33.66	74	49.24	38.6	17.89	65.39	100	0	P	H	
													H	
													H	
			10360	48.73	-25.27	74	61.58	39.79	14.86	67.5	100	0	P	V
			15540	43.6	-30.4	74	52.5	38.6	17.89	65.39	100	0	P	V
														V
802.11ac VHT20 CH 44 5220MHz		10440	47.21	-26.79	74	59.91	39.89	14.91	67.5	100	0	P	H	
		15660	39.91	-34.09	74	49.11	38.23	17.94	65.37	100	0	P	H	
													H	
													H	
			10440	48.66	-25.34	74	61.36	39.89	14.91	67.5	100	0	P	V
			15660	40.25	-33.75	74	49.45	38.23	17.94	65.37	100	0	P	V
														V
802.11ac VHT20 CH 48 5240MHz		10480	46.9	-27.1	74	59.49	39.97	14.94	67.5	100	0	P	H	
		15720	39.21	-34.79	74	48.57	38.03	17.97	65.36	100	0	P	H	
													H	
													H	
			10480	47.15	-26.85	74	59.74	39.97	14.94	67.5	100	0	P	V
			15720	41.26	-32.74	74	50.62	38.03	17.97	65.36	100	0	P	V
														V
Remark	1. No other spurious found.													
	2. All results are PASS against Peak and Average limit line.													



Band 1 5150~5250MHz

WIFI 802.11ac VHT40 (Band Edge @ 3m)

WIFI Ant. 1+2	Note	Frequency (MHz)	Level (dBμV/m)	Over Limit (dB)	Limit Line (dBμV/m)	Read Level (dBμV)	Antenna Factor (dB/m)	Cable Loss (dB)	Preamp Factor (dB)	Ant Pos (cm)	Table Pos (deg)	Peak Avg. (P/A)	Pol. (H/V)
802.11ac VHT40 CH 38 5190MHz		5148.95	56.41	-17.59	74	48.07	31.58	10.23	33.47	100	121	P	H
		5150	51.52	-2.48	54	43.18	31.58	10.23	33.47	100	121	A	H
	*	5190	95.72	-	-	87.33	31.62	10.24	33.47	100	121	P	H
	*	5190	89.37	-	-	80.98	31.62	10.24	33.47	100	121	A	H
		5413.25	47.83	-26.17	74	38.54	31.9	10.87	33.48	100	121	P	H
		5459.12	39.8	-14.2	54	30.5	31.94	10.84	33.48	100	121	A	H
		5149.85	60.17	-13.83	74	51.83	31.58	10.23	33.47	376	101	P	V
		5149.85	52.08	-1.92	54	43.74	31.58	10.23	33.47	376	101	A	V
	*	5190	100.34	-	-	91.95	31.62	10.24	33.47	376	101	P	V
	*	5190	92.64	-	-	84.25	31.62	10.24	33.47	376	101	A	V
		5392.79	48.87	-25.13	74	39.62	31.86	10.87	33.48	376	101	P	V
		5376.29	40.18	-13.82	54	31.07	31.84	10.75	33.48	376	101	A	V
802.11ac VHT40 CH 46 5230MHz		5094.8	48.64	-25.36	74	40.38	31.52	10.21	33.47	100	116	P	H
		5144.6	40.45	-13.55	54	32.11	31.58	10.23	33.47	100	116	A	H
	*	5230	98.4	-	-	89.82	31.68	10.37	33.47	100	116	P	H
	*	5230	90.2	-	-	81.62	31.68	10.37	33.47	100	116	A	H
		5413.47	48.91	-25.09	74	39.62	31.9	10.87	33.48	100	116	P	H
		5457.14	40.16	-13.84	54	30.86	31.94	10.84	33.48	100	116	A	H
		5039.6	48.43	-25.57	74	40.24	31.46	10.2	33.47	391	99	P	V
		5089.85	40.37	-13.63	54	32.11	31.52	10.21	33.47	391	99	A	V
	*	5230	100.17	-	-	91.59	31.68	10.37	33.47	391	99	P	V
	*	5230	93.81	-	-	85.23	31.68	10.37	33.47	391	99	A	V
	5373.76	52.48	-21.52	74	43.37	31.84	10.75	33.48	391	99	P	V	
	5389.71	39.96	-14.04	54	30.71	31.86	10.87	33.48	391	99	A	V	
Remark	1. No other spurious found. 2. All results are PASS against Peak and Average limit line.												



Band 1 5150~5250MHz

WIFI 802.11ac VHT40 (Harmonic @ 3m)

WIFI Ant. 1+2	Note	Frequency (MHz)	Level (dBμV/m)	Over Limit (dB)	Limit Line (dBμV/m)	Read Level (dBμV)	Antenna Factor (dB/m)	Cable Loss (dB)	Preamp Factor (dB)	Ant Pos (cm)	Table Pos (deg)	Peak Avg. (P/A)	Pol. (H/V)	
802.11ac VHT40 CH 38 5190MHz		10380	45.57	-28.43	74	58.4	39.81	14.86	67.5	100	0	P	H	
		15570	39.96	-34.04	74	48.96	38.49	17.9	65.39	100	0	P	H	
													H	
													H	
			10380	45.8	-28.2	74	58.63	39.81	14.86	67.5	100	0	P	V
			15570	39.67	-34.33	74	48.67	38.49	17.9	65.39	100	0	P	V
														V
802.11ac VHT40 CH 46 5230MHz		10465	46.28	-27.72	74	58.89	39.95	14.94	67.5	100	0	P	H	
		15690	39.36	-34.64	74	48.63	38.13	17.96	65.36	100	0	P	H	
													H	
													H	
			10460	44.23	-29.77	74	56.9	39.92	14.91	67.5	100	0	P	V
			15690	39.84	-34.16	74	49.11	38.13	17.96	65.36	100	0	P	V
														V
Remark	1. No other spurious found.													
	2. All results are PASS against Peak and Average limit line.													



Band 1 5150~5250MHz

WIFI 802.11ac VHT80 (Band Edge @ 3m)

WIFI Ant. 1+2	Note	Frequency (MHz)	Level (dBμV/m)	Over Limit (dB)	Limit Line (dBμV/m)	Read Level (dBμV)	Antenna Factor (dB/m)	Cable Loss (dB)	Preamp Factor (dB)	Ant Pos (cm)	Table Pos (deg)	Peak Avg. (P/A)	Pol. (H/V)
802.11ac VHT80 CH 42 5210MHz		5139.8	58.75	-15.25	74	50.42	31.58	10.22	33.47	100	197	P	H
		5148.05	50.84	-3.16	54	42.5	31.58	10.23	33.47	100	197	A	H
	*	5210	93.13	-	-	84.7	31.66	10.24	33.47	100	197	P	H
	*	5210	86.43	-	-	78	31.66	10.24	33.47	100	197	A	H
		5350.55	48.97	-25.03	74	39.88	31.82	10.75	33.48	100	197	P	H
		5352.2	41.47	-12.53	54	32.38	31.82	10.75	33.48	100	197	A	H
		5143.25	62.63	-11.37	74	54.29	31.58	10.23	33.47	353	100	P	V
		5141.75	53.42	-0.58	54	45.08	31.58	10.23	33.47	353	100	A	V
	*	5210	100.89	-	-	92.46	31.66	10.24	33.47	353	100	P	V
	*	5210	91.24	-	-	82.81	31.66	10.24	33.47	353	100	A	V
		5358.47	53.44	-20.56	74	44.35	31.82	10.75	33.48	353	100	P	V
	5351.54	43.65	-10.35	54	34.56	31.82	10.75	33.48	353	100	A	V	
Remark	1. No other spurious found. 2. All results are PASS against Peak and Average limit line.												



Band 1 5150~5250MHz

WIFI 802.11ac VHT80 (Harmonic @ 3m)

WIFI Ant. 1+2	Note	Frequency (MHz)	Level (dB μ V/m)	Over Limit (dB)	Limit Line (dB μ V/m)	Read Level (dB μ V)	Antenna Factor (dB/m)	Cable Loss (dB)	Preamp Factor (dB)	Ant Pos (cm)	Table Pos (deg)	Peak Avg. (P/A)	Pol. (H/V)	
802.11ac VHT80 CH 42 5210MHz		10420	45.38	-28.62	74	58.12	39.87	14.89	67.5	100	0	P	H	
		15630	39.2	-34.8	74	48.34	38.29	17.94	65.37	100	0	P	H	
													H	
													H	
			10420	44.93	-29.07	74	57.67	39.87	14.89	67.5	100	0	P	V
			15630	38.98	-35.02	74	48.12	38.29	17.94	65.37	100	0	P	V
														V
														V
Remark	1. No other spurious found. 2. All results are PASS against Peak and Average limit line.													



Band 2 - 5250~5350MHz

WIFI 802.11a (Band Edge @ 3m)

WIFI	Note	Frequency	Level	Over	Limit	Read	Antenna	Cable	Preamp	Ant	Table	Peak	Pol.
Ant.				Limit	Line	Level	Factor	Loss	Factor	Pos	Pos	Avg.	
1+2		(MHz)	(dBμV/m)	(dB)	(dBμV/m)	(dBμV)	(dB/m)	(dB)	(dB)	(cm)	(deg)	(P/A)	(H/V)
802.11a CH 52 5260MHz		5112.5	48.37	-25.63	74	40.08	31.54	10.22	33.47	100	208	P	H
		5115.05	39.75	-14.25	54	31.46	31.54	10.22	33.47	100	208	A	H
	*	5260	100.51	-	-	91.9	31.72	10.37	33.48	100	208	P	H
	*	5260	95.13	-	-	86.52	31.72	10.37	33.48	100	208	A	H
		5455.93	49.37	-24.63	74	40.07	31.94	10.84	33.48	100	208	P	H
		5453.4	39.21	-14.79	54	29.91	31.94	10.84	33.48	100	208	A	H
		5066.75	48.46	-25.54	74	40.24	31.48	10.21	33.47	370	98	P	V
		5072.15	39.58	-14.42	54	31.34	31.5	10.21	33.47	370	98	A	V
	*	5260	105.27	-	-	96.66	31.72	10.37	33.48	370	98	P	V
	*	5260	98.58	-	-	89.97	31.72	10.37	33.48	370	98	A	V
		5436.24	48	-26	74	38.72	31.92	10.84	33.48	370	98	P	V
		5459.67	39.48	-14.52	54	30.18	31.94	10.84	33.48	370	98	A	V
802.11a CH 60 5300MHz		5013.8	47.92	-26.08	74	39.78	31.42	10.19	33.47	109	212	P	H
		5097.95	39.6	-14.4	54	31.34	31.52	10.21	33.47	109	212	A	H
	*	5300	102.71	-	-	93.94	31.76	10.49	33.48	109	212	P	H
	*	5300	97.38	-	-	88.61	31.76	10.49	33.48	109	212	A	H
		5350.99	49.36	-24.64	74	40.27	31.82	10.75	33.48	109	212	P	H
		5350.22	42.68	-11.32	54	33.59	31.82	10.75	33.48	109	212	A	H
		5147	49.24	-24.76	74	40.9	31.58	10.23	33.47	363	103	P	V
		5082.2	39.55	-14.45	54	31.31	31.5	10.21	33.47	363	103	A	V
	*	5300	106.42	-	-	97.65	31.76	10.49	33.48	363	103	P	V
	*	5300	99.52	-	-	90.75	31.76	10.49	33.48	363	103	A	V
		5350	52.04	-21.96	74	42.95	31.82	10.75	33.48	363	103	P	V
		5350	42.97	-11.03	54	33.88	31.82	10.75	33.48	363	103	A	V



802.11a CH 64 5320MHz	*	5320	103.57	-	-	94.65	31.78	10.62	33.48	100	216	P	H
	*	5320	97.06	-	-	88.14	31.78	10.62	33.48	100	216	A	H
		5357.48	58.08	-15.92	74	48.99	31.82	10.75	33.48	100	216	P	H
		5350	51.75	-2.25	54	42.66	31.82	10.75	33.48	100	216	A	H
													H
													H
	*	5320	106.06	-	-	97.14	31.78	10.62	33.48	339	99	P	V
	*	5320	100.64	-	-	91.72	31.78	10.62	33.48	339	99	A	V
		5350.99	60.01	-13.99	74	50.92	31.82	10.75	33.48	339	99	P	V
		5350	53.8	-0.2	54	44.71	31.82	10.75	33.48	339	99	A	V
													V
													V
Remark	1. No other spurious found. 2. All results are PASS against Peak and Average limit line.												



Band 2 5250~5350MHz

WIFI 802.11a (Harmonic @ 3m)

WIFI Ant. 1+2	Note	Frequency (MHz)	Level (dBμV/m)	Over Limit (dB)	Limit Line (dBμV/m)	Read Level (dBμV)	Antenna Factor (dB/m)	Cable Loss (dB)	Preamp Factor (dB)	Ant Pos (cm)	Table Pos (deg)	Peak Avg. (P/A)	Pol. (H/V)
802.11a CH 52 5260MHz		10520	46.07	-27.93	74	58.58	40.01	14.96	67.48	400	0	P	H
		15780	39.95	-34.05	74	49.43	37.87	17.99	65.34	100	0	P	H
													H
													H
		10520	46.63	-27.37	74	59.14	40.01	14.96	67.48	400	0	P	V
		15780	43.86	-30.14	74	53.34	37.87	17.99	65.34	100	0	P	V
													V
													V
802.11a CH 60 5300MHz		10600	45.13	-28.87	74	57.45	40.06	15.02	67.4	100	0	P	H
		15900	40.59	-33.41	74	50.36	37.51	18.04	65.32	100	0	P	H
													H
													H
		10600	45.16	-28.84	74	57.48	40.06	15.02	67.4	100	0	P	V
		15900	42.96	-31.04	74	52.73	37.51	18.04	65.32	100	0	P	V
													V
													V
802.11a CH 64 5320MHz		10640	44.47	-29.53	74	56.71	40.08	15.04	67.36	100	0	P	H
		15960	41.22	-32.78	74	51.15	37.3	18.08	65.31	100	0	P	H
													H
													H
		10640	45.22	-28.78	74	57.46	40.08	15.04	67.36	100	0	P	V
		15960	46.07	-27.93	74	56	37.3	18.08	65.31	100	0	P	V
													V
													V
Remark	1. No other spurious found. 2. All results are PASS against Peak and Average limit line.												



Band 2 5250~5350MHz

WIFI 802.11n HT20 (Band Edge @ 3m)

WIFI Ant. 1+2	Note	Frequency (MHz)	Level (dBμV/m)	Over Limit (dB)	Limit Line (dBμV/m)	Read Level (dBμV)	Antenna Factor (dB/m)	Cable Loss (dB)	Preamp Factor (dB)	Ant Pos (cm)	Table Pos (deg)	Peak Avg. (P/A)	Pol. (H/V)
802.11n HT20 CH 52 5260MHz		5052.5	49.16	-24.84	74	40.97	31.46	10.2	33.47	100	217	P	H
		5086.1	39.71	-14.29	54	31.47	31.5	10.21	33.47	100	217	A	H
	*	5260	103.11	-	-	94.5	31.72	10.37	33.48	100	217	P	H
	*	5260	95.75	-	-	87.14	31.72	10.37	33.48	100	217	A	H
		5409.18	48.44	-25.56	74	39.17	31.88	10.87	33.48	100	217	P	H
		5440.86	39.34	-14.66	54	30.06	31.92	10.84	33.48	100	217	A	H
		5133.65	48.61	-25.39	74	40.3	31.56	10.22	33.47	388	97	P	V
		5087.9	39.77	-14.23	54	31.53	31.5	10.21	33.47	388	97	A	V
	*	5260	106.28	-	-	97.67	31.72	10.37	33.48	388	97	P	V
	*	5260	99.11	-	-	90.5	31.72	10.37	33.48	388	97	A	V
		5392.9	48.01	-25.99	74	38.76	31.86	10.87	33.48	388	97	P	V
		5418.64	39.39	-14.61	54	30.1	31.9	10.87	33.48	388	97	A	V
802.11n HT20 CH 60 5300MHz		5038.25	49.41	-24.59	74	41.22	31.46	10.2	33.47	111	217	P	H
		5074.1	39.51	-14.49	54	31.27	31.5	10.21	33.47	111	217	A	H
	*	5300	105.08	-	-	96.31	31.76	10.49	33.48	111	217	P	H
	*	5300	96.92	-	-	88.15	31.76	10.49	33.48	111	217	A	H
		5353.08	49.99	-24.01	74	40.9	31.82	10.75	33.48	111	217	P	H
		5350.99	42.21	-11.79	54	33.12	31.82	10.75	33.48	111	217	A	H
		5100.35	49.3	-24.7	74	41.03	31.52	10.22	33.47	364	98	P	V
		5025.05	39.74	-14.26	54	31.57	31.44	10.2	33.47	364	98	A	V
	*	5300	108.27	-	-	99.5	31.76	10.49	33.48	364	98	P	V
	*	5300	99.98	-	-	91.21	31.76	10.49	33.48	364	98	A	V
	5351.98	51.42	-22.58	74	42.33	31.82	10.75	33.48	364	98	P	V	
	5350.55	43.3	-10.7	54	34.21	31.82	10.75	33.48	364	98	A	V	



802.11n HT20 CH 64 5320MHz	*	5320	104.14	-	-	95.22	31.78	10.62	33.48	100	218	P	H
	*	5320	96.9	-	-	87.98	31.78	10.62	33.48	100	218	A	H
		5351.65	58.04	-15.96	74	48.95	31.82	10.75	33.48	100	218	P	H
		5350.22	49.91	-4.09	54	40.82	31.82	10.75	33.48	100	218	A	H
													H
													H
	*	5320	108.33	-	-	99.41	31.78	10.62	33.48	379	97	P	V
	*	5320	100.32	-	-	91.4	31.78	10.62	33.48	379	97	A	V
		5353.74	59.92	-14.08	74	50.83	31.82	10.75	33.48	379	97	P	V
		5351.32	51.72	-2.28	54	42.63	31.82	10.75	33.48	379	97	A	V
													V
													V
Remark	1. No other spurious found. 2. All results are PASS against Peak and Average limit line.												



Band 2 5250~5350MHz

WIFI 802.11n HT20 (Harmonic @ 3m)

WIFI Ant. 1+2	Note	Frequency (MHz)	Level (dBμV/m)	Over Limit (dB)	Limit Line (dBμV/m)	Read Level (dBμV)	Antenna Factor (dB/m)	Cable Loss (dB)	Preamp Factor (dB)	Ant Pos (cm)	Table Pos (deg)	Peak Avg. (P/A)	Pol. (H/V)	
802.11n HT20 CH 52 5260MHz		10520	46.76	-27.24	74	59.27	40.01	14.96	67.48	100	0	P	H	
		15780	40.47	-33.53	74	49.95	37.87	17.99	65.34	100	0	P	H	
													H	
													H	
			10520	46.91	-27.09	74	59.42	40.01	14.96	67.48	100	0	P	V
			15780	42.14	-31.86	74	51.62	37.87	17.99	65.34	100	0	P	V
														V
802.11n HT20 CH 60 5300MHz		10600	44.55	-29.45	74	56.87	40.06	15.02	67.4	100	0	P	H	
		15900	39.02	-34.98	74	48.79	37.51	18.04	65.32	100	0	P	H	
													H	
													H	
			10600	44.37	-29.63	74	56.69	40.06	15.02	67.4	100	0	P	V
			15900	42.46	-31.54	74	52.23	37.51	18.04	65.32	100	0	P	V
														V
802.11n HT20 CH 64 5320MHz		10640	45	-29	74	57.24	40.08	15.04	67.36	100	0	P	H	
		15960	39.06	-34.94	74	48.99	37.3	18.08	65.31	100	0	P	H	
													H	
													H	
			10640	44.61	-29.39	74	56.85	40.08	15.04	67.36	100	0	P	V
			15960	46.61	-27.39	74	56.54	37.3	18.08	65.31	100	0	P	V
														V
Remark	1. No other spurious found.													
	2. All results are PASS against Peak and Average limit line.													



Band 2 5250~5350MHz

WIFI 802.11n HT40 (Band Edge @ 3m)

WIFI Ant. 1+2	Note	Frequency (MHz)	Level (dBμV/m)	Over Limit (dB)	Limit Line (dBμV/m)	Read Level (dBμV)	Antenna Factor (dB/m)	Cable Loss (dB)	Preamp Factor (dB)	Ant Pos (cm)	Table Pos (deg)	Peak Avg. (P/A)	Pol. (H/V)
802.11n HT40 CH 54 5270MHz		5093.15	48.57	-25.43	74	40.31	31.52	10.21	33.47	100	116	P	H
		5109.95	40.37	-13.63	54	32.08	31.54	10.22	33.47	100	116	A	H
	*	5270	98.9	-	-	90.17	31.72	10.49	33.48	100	116	P	H
	*	5270	91.66	-	-	82.93	31.72	10.49	33.48	100	116	A	H
		5450.43	48.29	-25.71	74	38.99	31.94	10.84	33.48	100	116	P	H
		5355.06	40.34	-13.66	54	31.25	31.82	10.75	33.48	100	116	A	H
		5120.45	48.71	-25.29	74	40.42	31.54	10.22	33.47	386	97	P	V
		5115.35	40.41	-13.59	54	32.12	31.54	10.22	33.47	386	97	A	V
	*	5270	102.88	-	-	94.15	31.72	10.49	33.48	386	97	P	V
	*	5270	95.66	-	-	86.93	31.72	10.49	33.48	386	97	A	V
		5350.11	49.97	-24.03	74	40.88	31.82	10.75	33.48	386	97	P	V
		5350.11	42.79	-11.21	54	33.7	31.82	10.75	33.48	386	97	A	V
802.11n HT40 CH 62 5310MHz		5051.45	48.16	-25.84	74	39.97	31.46	10.2	33.47	115	221	P	H
		5051.9	40.27	-13.73	54	32.08	31.46	10.2	33.47	115	221	A	H
	*	5310	99.21	-	-	90.29	31.78	10.62	33.48	115	221	P	H
	*	5310	91.88	-	-	82.96	31.78	10.62	33.48	115	221	A	H
		5353.41	57.58	-16.42	74	48.49	31.82	10.75	33.48	115	221	P	H
		5354.95	51.64	-2.36	54	42.55	31.82	10.75	33.48	115	221	A	H
		5060.3	48.52	-25.48	74	40.3	31.48	10.21	33.47	362	97	P	V
		5063.45	40.63	-13.37	54	32.41	31.48	10.21	33.47	362	97	A	V
	*	5310	102.21	-	-	93.29	31.78	10.62	33.48	362	97	P	V
	*	5310	95.57	-	-	86.65	31.78	10.62	33.48	362	97	A	V
	5355.06	58.95	-15.05	74	49.86	31.82	10.75	33.48	362	97	P	V	
	5350.11	53.12	-0.88	54	44.03	31.82	10.75	33.48	362	97	A	V	
Remark	1. No other spurious found. 2. All results are PASS against Peak and Average limit line.												



Band 2 5250~5350MHz

WIFI 802.11n HT40 (Harmonic @ 3m)

WIFI Ant. 1+2	Note	Frequency (MHz)	Level (dBμV/m)	Over Limit (dB)	Limit Line (dBμV/m)	Read Level (dBμV)	Antenna Factor (dB/m)	Cable Loss (dB)	Preamp Factor (dB)	Ant Pos (cm)	Table Pos (deg)	Peak Avg. (P/A)	Pol. (H/V)
802.11n HT40 CH 54 5270MHz		10540	45.06	-28.94	74	57.55	40.02	14.96	67.47	100	0	P	H
		15810	38.22	-35.78	74	47.78	37.77	18.01	65.34	100	0	P	H
													H
													H
		10540	44.77	-29.23	74	57.26	40.02	14.96	67.47	100	0	P	V
		15810	38.97	-35.03	74	48.53	37.77	18.01	65.34	100	0	P	V
													V
													V
802.11n HT40 CH 62 5310MHz		10620	44.77	-29.23	74	57.06	40.07	15.02	67.38	100	0	P	H
		15930	37.5	-36.5	74	47.34	37.41	18.06	65.31	100	0	P	H
													H
													H
		10620	42.87	-31.13	74	55.16	40.07	15.02	67.38	100	0	P	V
		15930	37.39	-36.61	74	47.23	37.41	18.06	65.31	100	0	P	V
													V
													V
Remark	1. No other spurious found. 2. All results are PASS against Peak and Average limit line.												



Band 2 5250~5350MHz

WIFI 802.11ac VHT20 (Band Edge @ 3m)

WIFI Ant. 1+2	Note	Frequency (MHz)	Level (dBμV/m)	Over Limit (dB)	Limit Line (dBμV/m)	Read Level (dBμV)	Antenna Factor (dB/m)	Cable Loss (dB)	Preamp Factor (dB)	Ant Pos (cm)	Table Pos (deg)	Peak Avg. (P/A)	Pol. (H/V)
802.11ac VHT20 CH 52 5260MHz		5059.55	48.2	-25.8	74	39.99	31.48	10.2	33.47	100	116	P	H
		5041.85	39.61	-14.39	54	31.42	31.46	10.2	33.47	100	116	A	H
	*	5260	104.48	-	-	95.87	31.72	10.37	33.48	100	116	P	H
	*	5260	96.3	-	-	87.69	31.72	10.37	33.48	100	116	A	H
		5378.82	48.56	-25.44	74	39.43	31.86	10.75	33.48	100	217	P	H
		5443.28	40.32	-13.68	54	31.04	31.92	10.84	33.48	100	217	P	H
		5144.15	48.63	-25.37	74	40.29	31.58	10.23	33.47	367	102	P	V
		5085.05	39.61	-14.39	54	31.37	31.5	10.21	33.47	367	102	A	V
	*	5260	107.9	-	-	99.29	31.72	10.37	33.48	367	102	P	V
	*	5260	100.33	-	-	91.72	31.72	10.37	33.48	367	102	A	V
		5423.48	49.01	-24.99	74	39.75	31.9	10.84	33.48	388	97	P	V
		5379.81	40.03	-13.97	54	30.9	31.86	10.75	33.48	388	97	P	V
802.11ac VHT20 CH 60 5300MHz		5008.7	49.5	-24.5	74	41.36	31.42	10.19	33.47	109	117	P	H
		5128.85	39.73	-14.27	54	31.42	31.56	10.22	33.47	109	117	A	H
	*	5300	103.1	-	-	94.33	31.76	10.49	33.48	109	117	P	H
	*	5300	95.13	-	-	86.36	31.76	10.49	33.48	109	117	A	H
		5430.08	48.69	-25.31	74	39.41	31.92	10.84	33.48	109	117	P	H
		5350	40.62	-13.38	54	31.53	31.82	10.75	33.48	109	117	A	H
		5003	48.69	-25.31	74	40.57	31.4	10.19	33.47	360	100	P	V
		5082.05	39.55	-14.45	54	31.31	31.5	10.21	33.47	360	100	A	V
	*	5300	108.8	-	-	100.03	31.76	10.49	33.48	360	100	P	V
	*	5300	99.85	-	-	91.08	31.76	10.49	33.48	360	100	A	V
	5354.18	52.6	-21.4	74	43.51	31.82	10.75	33.48	360	100	P	V	
	5350.66	43.87	-10.13	54	34.78	31.82	10.75	33.48	360	100	A	V	



802.11ac VHT20 CH 64 5320MHz	*	5320	102.88	-	-	93.96	31.78	10.62	33.48	100	117	P	H
	*	5320	94.5	-	-	85.58	31.78	10.62	33.48	100	117	A	H
		5350	54.61	-19.39	74	45.52	31.82	10.75	33.48	100	117	P	H
		5350	47.45	-6.55	54	38.36	31.82	10.75	33.48	100	117	A	H
													H
													H
	*	5320	107.56	-	-	98.64	31.78	10.62	33.48	357	103	P	V
	*	5320	99.19	-	-	90.27	31.78	10.62	33.48	357	103	A	V
		5350	59.52	-14.48	74	50.43	31.82	10.75	33.48	357	103	P	V
		5350	52.86	-1.14	54	43.77	31.82	10.75	33.48	357	103	A	V
													V
													V
Remark	1. No other spurious found. 2. All results are PASS against Peak and Average limit line.												



Band 2 5250~5350MHz

WIFI 802.11ac VHT20 (Harmonic @ 3m)

WIFI Ant. 1+2	Note	Frequency (MHz)	Level (dBμV/m)	Over Limit (dB)	Limit Line (dBμV/m)	Read Level (dBμV)	Antenna Factor (dB/m)	Cable Loss (dB)	Preamp Factor (dB)	Ant Pos (cm)	Table Pos (deg)	Peak Avg. (P/A)	Pol. (H/V)	
802.11ac VHT20 CH 52 5260MHz		10520	47.33	-26.67	74	59.84	40.01	14.96	67.48	100	0	P	H	
		15780	37.52	-36.48	74	47	37.87	17.99	65.34	100	0	P	H	
													H	
													H	
			10520	46.54	-27.46	74	59.05	40.01	14.96	67.48	100	0	P	V
			15780	41.91	-32.09	74	51.39	37.87	17.99	65.34	100	0	P	V
														V
802.11ac VHT20 CH 60 5300MHz		10600	44.42	-29.58	74	56.74	40.06	15.02	67.4	100	0	P	H	
		15900	37.74	-36.26	74	47.51	37.51	18.04	65.32	100	0	P	H	
													H	
													H	
			10600	45.71	-28.29	74	58.03	40.06	15.02	67.4	100	0	P	V
			15900	41.82	-32.18	74	51.59	37.51	18.04	65.32	100	0	P	V
														V
802.11ac VHT20 CH 64 5320MHz		10640	45.02	-28.98	74	57.26	40.08	15.04	67.36	100	0	P	H	
		15960	37.46	-36.54	74	47.39	37.3	18.08	65.31	100	0	P	H	
													H	
													H	
			10640	45.26	-28.74	74	57.5	40.08	15.04	67.36	100	0	P	V
			15960	42.78	-31.22	74	52.71	37.3	18.08	65.31	100	0	P	V
														V
Remark	1. No other spurious found.													
	2. All results are PASS against Peak and Average limit line.													



Band 2 5250~5350MHz

WIFI 802.11ac VHT40 (Band Edge @ 3m)

WIFI Ant. 1+2	Note	Frequency (MHz)	Level (dBμV/m)	Over Limit (dB)	Limit Line (dBμV/m)	Read Level (dBμV)	Antenna Factor (dB/m)	Cable Loss (dB)	Preamp Factor (dB)	Ant Pos (cm)	Table Pos (deg)	Peak Avg. (P/A)	Pol. (H/V)
802.11ac VHT40 CH 54 5270MHz		5081.15	48.74	-25.26	74	40.5	31.5	10.21	33.47	100	195	P	H
		5105.9	40.52	-13.48	54	32.23	31.54	10.22	33.47	100	195	A	H
	*	5270	97.9	-	-	89.17	31.72	10.49	33.48	100	195	P	H
	*	5270	91.05	-	-	82.32	31.72	10.49	33.48	100	195	A	H
		5358.69	50.14	-23.86	74	41.05	31.82	10.75	33.48	100	195	P	H
		5350.55	41.76	-12.24	54	32.67	31.82	10.75	33.48	100	195	A	H
		5137.7	49.77	-24.23	74	41.46	31.56	10.22	33.47	386	99	P	V
		5061.95	40.23	-13.77	54	32.01	31.48	10.21	33.47	386	99	A	V
	*	5270	102.69	-	-	93.96	31.72	10.49	33.48	386	99	P	V
	*	5270	94.67	-	-	85.94	31.72	10.49	33.48	386	99	A	V
		5422.6	52.36	-21.64	74	43.1	31.9	10.84	33.48	386	99	P	V
		5353.08	42.5	-11.5	54	33.41	31.82	10.75	33.48	386	99	A	V
802.11ac VHT40 CH 62 5310MHz		5041.4	48.96	-25.04	74	40.77	31.46	10.2	33.47	108	210	P	H
		5085.8	40.22	-13.78	54	31.98	31.5	10.21	33.47	108	210	A	H
	*	5310	99.91	-	-	90.99	31.78	10.62	33.48	108	210	P	H
	*	5310	91.9	-	-	82.98	31.78	10.62	33.48	108	210	A	H
		5350.55	57.83	-16.17	74	48.74	31.82	10.75	33.48	108	210	P	H
		5351.32	50.29	-3.71	54	41.2	31.82	10.75	33.48	108	210	A	H
		5020.55	48.93	-25.07	74	40.76	31.44	10.2	33.47	359	100	P	V
		5100.5	40.46	-13.54	54	32.19	31.52	10.22	33.47	359	100	A	V
	*	5310	104.2	-	-	95.28	31.78	10.62	33.48	359	100	P	V
	*	5310	96.15	-	-	87.23	31.78	10.62	33.48	359	100	A	V
	5351.87	61.12	-12.88	74	52.03	31.82	10.75	33.48	359	100	P	V	
	5354.95	53.74	-0.26	54	44.65	31.82	10.75	33.48	359	100	A	V	
Remark	1. No other spurious found. 2. All results are PASS against Peak and Average limit line.												



Band 2 5250~5350MHz

WIFI 802.11ac VHT40 (Harmonic @ 3m)

WIFI Ant. 1+2	Note	Frequency (MHz)	Level (dBμV/m)	Over Limit (dB)	Limit Line (dBμV/m)	Read Level (dBμV)	Antenna Factor (dB/m)	Cable Loss (dB)	Preamp Factor (dB)	Ant Pos (cm)	Table Pos (deg)	Peak Avg. (P/A)	Pol. (H/V)	
802.11ac VHT40 CH 54 5270MHz		10540	46.1	-27.9	74	58.59	40.02	14.96	67.47	100	0	P	H	
		15810	37.46	-36.54	74	47.02	37.77	18.01	65.34	100	0	P	H	
													H	
													H	
			10540	45.42	-28.58	74	57.91	40.02	14.96	67.47	100	0	P	V
			15810	38.61	-35.39	74	48.17	37.77	18.01	65.34	100	0	P	V
														V
802.11ac VHT40 CH 62 5310MHz		10620	43.11	-30.89	74	55.4	40.07	15.02	67.38	100	0	P	H	
		15930	36.67	-37.33	74	46.51	37.41	18.06	65.31	100	0	P	H	
													H	
													H	
			10620	43.6	-30.4	74	55.89	40.07	15.02	67.38	100	0	P	V
			15930	37.35	-36.65	74	47.19	37.41	18.06	65.31	100	0	P	V
														V
Remark	1. No other spurious found.													
	2. All results are PASS against Peak and Average limit line.													



Band 2 5250~5350MHz

WIFI 802.11ac VHT80 (Band Edge @ 3m)

WIFI Ant. 1+2	Note	Frequency (MHz)	Level (dBμV/m)	Over Limit (dB)	Limit Line (dBμV/m)	Read Level (dBμV)	Antenna Factor (dB/m)	Cable Loss (dB)	Preamp Factor (dB)	Ant Pos (cm)	Table Pos (deg)	Peak Avg. (P/A)	Pol. (H/V)
802.11ac VHT80 CH 58 5290MHz		5135.45	48.57	-25.43	74	40.26	31.56	10.22	33.47	109	193	P	H
		5148.05	41.01	-12.99	54	32.67	31.58	10.23	33.47	109	193	A	H
	*	5290	96.08	-	-	87.33	31.74	10.49	33.48	109	193	P	H
	*	5290	87.49	-	-	78.74	31.74	10.49	33.48	109	193	A	H
		5352.97	57.45	-16.55	74	48.36	31.82	10.75	33.48	109	193	P	H
		5353.19	49.54	-4.46	54	40.45	31.82	10.75	33.48	109	193	A	H
		5150	48.31	-25.69	74	39.97	31.58	10.23	33.47	339	103	P	V
		5149.4	42.01	-11.99	54	33.67	31.58	10.23	33.47	339	103	A	V
	*	5290	100.35	-	-	91.6	31.74	10.49	33.48	339	103	P	V
	*	5290	91.03	-	-	82.28	31.74	10.49	33.48	339	103	A	V
		5361.22	61.2	-12.8	74	52.09	31.84	10.75	33.48	339	103	P	V
		5352.42	53.52	-0.48	54	44.43	31.82	10.75	33.48	339	103	A	V
Remark	1. No other spurious found. 2. All results are PASS against Peak and Average limit line.												



Band 2 5250~5350MHz

WIFI 802.11ac VHT80 (Harmonic @ 3m)

WIFI Ant. 1+2	Note	Frequency (MHz)	Level (dBμV/m)	Over Limit (dB)	Limit Line (dBμV/m)	Read Level (dBμV)	Antenna Factor (dB/m)	Cable Loss (dB)	Preamp Factor (dB)	Ant Pos (cm)	Table Pos (deg)	Peak Avg. (P/A)	Pol. (H/V)	
802.11ac VHT80 CH 58 5290MHz		10580	43.02	-30.98	74	55.39	40.05	14.99	67.41	100	0	P	H	
		15870	39.07	-34.93	74	48.79	37.56	18.04	65.32	100	0	P	H	
													H	
													H	
			10580	42.05	-31.95	74	54.42	40.05	14.99	67.41	100	0	P	V
			15870	38.15	-35.85	74	47.87	37.56	18.04	65.32	100	0	P	V
														V
														V
Remark	1. No other spurious found. 2. All results are PASS against Peak and Average limit line.													



Band 3 - 5470~5725MHz

WIFI 802.11a (Band Edge @ 3m)

WIFI	Note	Frequency	Level	Over	Limit	Read	Antenna	Cable	Preamp	Ant	Table	Peak	Pol.	
Ant.				Limit	Line	Level	Factor	Loss	Factor	Pos	Pos	Avg.		
1+2		(MHz)	(dBμV/m)	(dB)	(dBμV/m)	(dBμV)	(dB/m)	(dB)	(dB)	(cm)	(deg)	(P/A)	(H/V)	
802.11a CH 100 5500MHz		5459.92	54.26	-19.74	74	44.96	31.94	10.84	33.48	100	115	P	H	
		5469.84	62.43	-5.87	68.3	53.14	31.96	10.81	33.48	100	115	P	H	
		5460	47.94	-6.06	54	38.64	31.94	10.84	33.48	100	115	A	H	
	*	5500	104.13	-	-	94.8	32	10.81	33.48	100	115	P	H	
	*	5500	94.45	-	-	85.12	32	10.81	33.48	100	115	A	H	
														H
			5459.12	59.59	-14.41	74	50.29	31.94	10.84	33.48	372	100	P	V
			5468.08	67.01	-1.29	68.3	57.72	31.96	10.81	33.48	372	100	P	V
			5460	53.28	-0.72	54	43.98	31.94	10.84	33.48	372	100	A	V
	*		5500	109.47	-	-	100.14	32	10.81	33.48	372	100	P	V
	*		5500	100.54	-	-	91.21	32	10.81	33.48	372	100	A	V
														V
802.11a CH 116 5580MHz		5456.08	48.41	-25.59	74	39.11	31.94	10.84	33.48	100	211	P	H	
		5461.04	39.36	-14.64	54	30.09	31.94	10.81	33.48	100	211	A	H	
	*	5580	104.88	-	-	95.56	32.1	10.74	33.52	100	211	P	H	
	*	5580	98.38	-	-	89.06	32.1	10.74	33.52	100	211	A	H	
			5747.48	49.1	-24.9	74	39.7	32.34	10.63	33.57	100	211	P	H
			5750.68	39.82	-14.18	54	30.42	32.34	10.63	33.57	100	211	A	H
			5455.44	48.81	-25.19	74	39.51	31.94	10.84	33.48	343	98	P	V
			5462.8	39.48	-14.52	54	30.19	31.96	10.81	33.48	343	98	A	V
	*		5580	106.65	-	-	97.33	32.1	10.74	33.52	343	98	P	V
	*		5580	100.25	-	-	90.93	32.1	10.74	33.52	343	98	A	V
			5749.16	48.16	-25.84	74	38.76	32.34	10.63	33.57	343	98	P	V
			5758.76	39.84	-14.16	54	30.43	32.36	10.63	33.58	343	98	A	V



802.11a CH 140 5700MHz	*	5700	103.53	-	-	94.15	32.27	10.67	33.56	100	227	P	H
	*	5700	96.48	-	-	87.1	32.27	10.67	33.56	100	227	A	H
		5725.8	60.77	-13.23	74	51.38	32.31	10.65	33.57	100	227	P	H
		5726.2	51.96	-2.04	54	42.57	32.31	10.65	33.57	100	227	A	H
													H
													H
	*	5700	105.14	-	-	95.76	32.27	10.67	33.56	350	104	P	V
	*	5700	98.32	-	-	88.94	32.27	10.67	33.56	350	104	A	V
		5726.92	61.65	-12.35	74	52.26	32.31	10.65	33.57	350	104	P	V
		5726.2	52.59	-1.41	54	43.2	32.31	10.65	33.57	350	104	A	V
													V
													V
Remark	1. No other spurious found. 2. All results are PASS against Peak and Average limit line.												



Band 3 - 5470~5725MHz

WIFI 802.11a (Harmonic @ 3m)

WIFI Ant. 1+2	Note	Frequency (MHz)	Level (dBμV/m)	Over Limit (dB)	Limit Line (dBμV/m)	Read Level (dBμV)	Antenna Factor (dB/m)	Cable Loss (dB)	Preamp Factor (dB)	Ant Pos (cm)	Table Pos (deg)	Peak Avg. (P/A)	Pol. (H/V)
802.11a CH 100 5500MHz		11000	45.91	-28.09	74	57.34	40.3	15.27	67	100	0	P	H
		16500	44.12	-24.18	68.3	50.93	38.9	18.29	64	100	0	P	H
													H
													H
		11000	48.62	-25.38	74	60.05	40.3	15.27	67	100	0	P	V
		16500	49.51	-18.79	68.3	56.32	38.9	18.29	64	100	0	P	V
													V
													V
802.11a CH 116 5580MHz		11160	48.05	-25.95	74	59.07	40.17	15.38	66.57	100	0	P	H
		16740	40.02	-33.98	74	45.95	39.58	18.39	63.9	100	0	P	H
													H
													H
		11160	48.56	-25.44	74	59.58	40.17	15.38	66.57	100	0	P	V
		16740	41.98	-32.02	74	47.91	39.58	18.39	63.9	100	0	P	V
													V
													V
802.11a CH 140 5700MHz		11400	47.06	-26.94	74	57.51	39.98	15.53	65.96	100	0	P	H
		17100	41.77	-32.23	74	46.56	40.6	18.53	63.92	100	0	P	H
													H
													H
		11400	48.92	-25.08	74	59.37	39.98	15.53	65.96	100	0	P	V
		17100	42.95	-31.05	74	47.74	40.6	18.53	63.92	100	0	P	V
													V
													V
Remark	1. No other spurious found. 2. All results are PASS against Peak and Average limit line.												



Band 3 - 5470~5725MHz

WIFI 802.11n HT20 (Band Edge @ 3m)

WIFI Ant. 1+2	Note	Frequency (MHz)	Level (dBμV/m)	Over Limit (dB)	Limit Line (dBμV/m)	Read Level (dBμV)	Antenna Factor (dB/m)	Cable Loss (dB)	Preamp Factor (dB)	Ant Pos (cm)	Table Pos (deg)	Peak Avg. (P/A)	Pol. (H/V)	
802.11n HT20 CH 100 5500MHz		5457.84	56.28	-17.72	74	46.98	31.94	10.84	33.48	100	234	P	H	
		5470	65.93	-2.37	68.3	56.64	31.96	10.81	33.48	100	234	P	H	
		5459.78	50.83	-3.17	54	41.53	31.94	10.84	33.48	100	234	A	H	
	*	5500	106.22	-	-	96.89	32	10.81	33.48	100	234	P	H	
	*	5500	94.86	-	-	85.53	32	10.81	33.48	100	234	A	H	
														H
			5456.56	59.3	-14.7	74	50	31.94	10.84	33.48	372	98	P	V
			5470	68.2	-0.1	68.3	58.91	31.96	10.81	33.48	372	98	P	V
			5459.67	52.18	-1.82	54	42.88	31.94	10.84	33.48	372	98	A	V
	*		5500	110.11	-	-	100.78	32	10.81	33.48	372	98	P	V
	*		5500	100.72	-	-	91.39	32	10.81	33.48	372	98	A	V
													V	
802.11n HT20 CH 116 5580MHz		5463.76	48.76	-25.24	74	39.47	31.96	10.81	33.48	100	235	P	H	
		5464.56	39.4	-14.6	54	30.11	31.96	10.81	33.48	100	235	A	H	
	*	5580	106.82	-	-	97.5	32.1	10.74	33.52	100	235	P	H	
	*	5580	98.84	-	-	89.52	32.1	10.74	33.52	100	235	A	H	
			5756.36	48.79	-25.21	74	39.38	32.36	10.63	33.58	100	235	P	H
			5745.8	39.81	-14.19	54	30.41	32.34	10.63	33.57	100	235	A	H
			5448.88	48.52	-25.48	74	39.22	31.94	10.84	33.48	347	100	P	V
			5460.88	39.51	-14.49	54	30.24	31.94	10.81	33.48	347	100	A	V
	*		5580	108.39	-	-	99.07	32.1	10.74	33.52	347	100	P	V
	*		5580	100.54	-	-	91.22	32.1	10.74	33.52	347	100	A	V
			5758.76	49.44	-24.56	74	40.03	32.36	10.63	33.58	347	100	P	V
		5744.44	39.72	-14.28	54	30.32	32.34	10.63	33.57	347	100	A	V	



802.11n HT20 CH 140 5700MHz	*	5700	103.46	-	-	94.08	32.27	10.67	33.56	100	224	P	H
	*	5700	95.8	-	-	86.42	32.27	10.67	33.56	100	224	A	H
		5726.36	62.67	-5.63	68.3	53.28	32.31	10.65	33.57	100	224	P	H
													H
													H
													H
	*	5700	105.89	-	-	96.51	32.27	10.67	33.56	349	101	P	V
	*	5700	97.63	-	-	88.25	32.27	10.67	33.56	349	101	A	V
		5725	61.23	-7.07	68.3	51.84	32.31	10.65	33.57	349	101	P	V
													V
													V
													V
Remark	1. No other spurious found. 2. All results are PASS against Peak and Average limit line.												



Band 3 - 5470~5725MHz

WIFI 802.11n HT20 (Harmonic @ 3m)

WIFI Ant. 1+2	Note	Frequency (MHz)	Level (dBμV/m)	Over Limit (dB)	Limit Line (dBμV/m)	Read Level (dBμV)	Antenna Factor (dB/m)	Cable Loss (dB)	Preamp Factor (dB)	Ant Pos (cm)	Table Pos (deg)	Peak Avg. (P/A)	Pol. (H/V)	
802.11n HT20 CH 100 5500MHz		11000	45.25	-28.75	74	56.68	40.3	15.27	67	100	0	P	H	
		16500	43.75	-24.55	68.3	50.56	38.9	18.29	64	100	0	P	H	
													H	
													H	
			11000	47.3	-26.7	74	58.73	40.3	15.27	67	100	0	P	V
			16500	46.92	-21.38	68.3	53.73	38.9	18.29	64	100	0	P	V
														V
802.11n HT20 CH 116 5580MHz		11160	47.83	-26.17	74	58.85	40.17	15.38	66.57	100	0	P	H	
		16740	40.23	-33.77	74	46.16	39.58	18.39	63.9	100	0	P	H	
													H	
													H	
			11160	47.84	-26.16	74	58.86	40.17	15.38	66.57	100	0	P	V
			16740	40.26	-33.74	74	46.19	39.58	18.39	63.9	100	0	P	V
														V
802.11n HT20 CH 140 5700MHz		11400	45.9	-28.1	74	56.35	39.98	15.53	65.96	100	0	P	H	
		17100	42.25	-26.05	68.3	47.04	40.6	18.53	63.92	100	0	P	H	
													H	
													H	
			11400	48.35	-25.65	74	58.8	39.98	15.53	65.96	100	0	P	V
			17100	41.51	-26.79	68.3	46.3	40.6	18.53	63.92	100	0	P	V
														V
Remark	1. No other spurious found.													
	2. All results are PASS against Peak and Average limit line.													



Band 3 - 5470~5725MHz

WIFI 802.11n HT40 (Band Edge @ 3m)

WIFI Ant. 1+2	Note	Frequency (MHz)	Level (dBμV/m)	Over Limit (dB)	Limit Line (dBμV/m)	Read Level (dBμV)	Antenna Factor (dB/m)	Cable Loss (dB)	Preamp Factor (dB)	Ant Pos (cm)	Table Pos (deg)	Peak Avg. (P/A)	Pol. (H/V)
802.11n HT40 CH 102 5510MHz		5457.52	62.81	-11.19	74	53.51	31.94	10.84	33.48	100	235	P	H
		5470	67.54	-0.76	68.3	58.25	31.96	10.81	33.48	100	235	P	H
		5457.47	53.59	-0.41	54	44.29	31.94	10.84	33.48	100	235	A	H
	*	5510	101.45	-	-	92.17	32	10.77	33.49	100	235	P	H
	*	5510	93.66	-	-	84.38	32	10.77	33.49	100	235	A	H
		5739.4	47.75	-20.55	68.3	38.33	32.34	10.65	33.57	100	235	P	H
		5458.96	61.88	-12.12	74	52.58	31.94	10.84	33.48	374	101	P	V
		5468.24	67.47	-0.83	68.3	58.18	31.96	10.81	33.48	374	101	P	V
		5458.68	53.84	-0.16	54	44.54	31.94	10.84	33.48	374	101	A	V
	*	5510	103.6	-	-	94.32	32	10.77	33.49	374	101	P	V
	*	5510	96.5	-	-	87.22	32	10.77	33.49	374	101	A	V
		5744.52	47.78	-20.52	68.3	38.38	32.34	10.63	33.57	374	101	P	V
802.11n HT40 CH 110 5550MHz		5464.88	50.64	-23.36	74	41.35	31.96	10.81	33.48	100	215	P	H
		5469.52	44.05	-9.95	54	34.76	31.96	10.81	33.48	100	215	A	H
	*	5550	102.27	-	-	92.96	32.07	10.74	33.5	100	215	P	H
	*	5550	95.06	-	-	85.75	32.07	10.74	33.5	100	215	A	H
		5764.12	49.31	-24.69	74	39.9	32.36	10.63	33.58	100	215	P	H
		5761.96	40.48	-13.52	54	31.07	32.36	10.63	33.58	100	215	A	H
		5461.84	56.48	-17.52	74	47.21	31.94	10.81	33.48	368	102	P	V
		5470	44.49	-9.51	54	35.2	31.96	10.81	33.48	368	102	A	V
	*	5550	104.87	-	-	95.56	32.07	10.74	33.5	368	102	P	V
	*	5550	97.36	-	-	88.05	32.07	10.74	33.5	368	102	A	V
	5730.76	48.34	-25.66	74	38.95	32.31	10.65	33.57	368	102	P	V	
	5754.2	40.28	-13.72	54	30.86	32.36	10.63	33.57	368	102	A	V	



802.11n HT40 CH 134 5670MHz		5450.8	50.99	-23.01	74	41.69	31.94	10.84	33.48	100	213	P	H
		5439.6	39.99	-14.01	54	30.71	31.92	10.84	33.48	100	213	A	H
	*	5670	100.55	-	-	91.19	32.24	10.67	33.55	100	213	P	H
	*	5670	93.11	-	-	83.75	32.24	10.67	33.55	100	213	A	H
		5734.52	54.11	-19.89	74	44.69	32.34	10.65	33.57	100	213	P	H
		5725.08	47.04	-6.96	54	37.65	32.31	10.65	33.57	100	213	A	H
		5412.56	47.75	-26.25	74	38.46	31.9	10.87	33.48	350	97	P	V
		5451.6	40.16	-13.84	54	30.86	31.94	10.84	33.48	350	97	A	V
	*	5670	101.86	-	-	92.5	32.24	10.67	33.55	350	97	P	V
	*	5670	94.7	-	-	85.34	32.24	10.67	33.55	350	97	A	V
		5727.4	56.95	-17.05	74	47.56	32.31	10.65	33.57	350	97	P	V
		5725.16	48.39	-5.61	54	39	32.31	10.65	33.57	350	97	A	V
Remark	1. No other spurious found. 2. All results are PASS against Peak and Average limit line.												



Band 3 - 5470~5725MHz

WIFI 802.11n HT40 (Harmonic @ 3m)

WIFI Ant. 1+2	Note	Frequency (MHz)	Level (dBμV/m)	Over Limit (dB)	Limit Line (dBμV/m)	Read Level (dBμV)	Antenna Factor (dB/m)	Cable Loss (dB)	Preamp Factor (dB)	Ant Pos (cm)	Table Pos (deg)	Peak Avg. (P/A)	Pol. (H/V)	
802.11n HT40 CH 102 5510MHz		11020	43.91	-30.09	74	55.31	40.29	15.27	66.96	100	0	P	H	
		16530	38.91	-29.39	68.3	45.59	39	18.31	63.99	100	0	P	H	
													H	
													H	
			11020	46.26	-27.74	74	57.66	40.29	15.27	66.96	100	0	P	V
			16530	38.27	-30.03	68.3	44.95	39	18.31	63.99	100	0	P	V
														V
802.11n HT40 CH 110 5550MHz		11100	45.17	-28.83	74	56.36	40.22	15.33	66.74	100	0	P	H	
		16650	39	-35	74	45.25	39.33	18.36	63.94	100	0	P	H	
													H	
													H	
			11100	46.17	-27.83	74	57.36	40.22	15.33	66.74	100	0	P	V
			16650	39.94	-34.06	74	46.19	39.33	18.36	63.94	100	0	P	V
														V
802.11n HT40 CH 134 5670MHz		11340	46.49	-27.51	74	57.11	40.03	15.48	66.13	100	0	P	H	
		17010	40.75	-33.25	74	45.72	40.35	18.5	63.82	100	0	P	H	
													H	
													H	
			11340	46.33	-27.67	74	56.95	40.03	15.48	66.13	100	0	P	V
			17010	40.82	-33.18	74	45.79	40.35	18.5	63.82	100	0	P	V
														V
Remark	1. No other spurious found. 2. All results are PASS against Peak and Average limit line.													



Band 3 - 5470~5725MHz

WIFI 802.11ac VHT20 (Band Edge @ 3m)

WIFI Ant. 1+2	Note	Frequency (MHz)	Level (dBμV/m)	Over Limit (dB)	Limit Line (dBμV/m)	Read Level (dBμV)	Antenna Factor (dB/m)	Cable Loss (dB)	Preamp Factor (dB)	Ant Pos (cm)	Table Pos (deg)	Peak Avg. (P/A)	Pol. (H/V)	
802.11ac VHT20 CH 100 5500MHz		5461	54.19	-14.11	68.3	44.92	31.94	10.81	33.48	100	115	P	H	
		5467.28	62.35	-5.95	68.3	53.06	31.96	10.81	33.48	100	115	P	H	
		5459.78	47.64	-6.36	54	38.34	31.94	10.84	33.48	100	115	A	H	
	*	5500	104.14	-	-	94.81	32	10.81	33.48	100	115	P	H	
	*	5500	94.28	-	-	84.95	32	10.81	33.48	100	115	A	H	
														H
			5459.6	62.6	-11.4	74	53.3	31.94	10.84	33.48	374	99	P	V
			5468.08	68.21	-0.09	68.3	58.92	31.96	10.81	33.48	374	99	P	V
			5459.23	52.2	-1.8	54	42.9	31.94	10.84	33.48	374	99	A	V
	*		5500	109.76	-	-	100.43	32	10.81	33.48	374	99	P	V
	*		5500	100.43	-	-	91.1	32	10.81	33.48	374	99	A	V
													V	
802.11ac VHT20 CH 116 5580MHz		5451.92	47.69	-26.31	74	38.39	31.94	10.84	33.48	100	231	P	H	
		5463.92	39.48	-14.52	54	30.19	31.96	10.81	33.48	100	231	A	H	
	*	5580	105.9	-	-	96.58	32.1	10.74	33.52	100	231	P	H	
	*	5580	97.43	-	-	88.11	32.1	10.74	33.52	100	231	A	H	
			5744.84	48.1	-25.9	74	38.7	32.34	10.63	33.57	100	231	P	H
			5765	39.54	-14.46	54	30.13	32.36	10.63	33.58	100	231	A	H
			5424.08	47.94	-26.06	74	38.68	31.9	10.84	33.48	342	104	P	V
			5469.2	39.6	-14.4	54	30.31	31.96	10.81	33.48	342	104	A	V
	*		5580	108.1	-	-	98.78	32.1	10.74	33.52	342	104	P	V
	*		5580	99.74	-	-	90.42	32.1	10.74	33.52	342	104	A	V
			5740.6	48.03	-25.97	74	38.63	32.34	10.63	33.57	342	104	P	V
		5759.4	39.71	-14.29	54	30.3	32.36	10.63	33.58	342	104	A	V	



802.11ac VHT20 CH 140 5700MHz	*	5700	102.74	-	-	93.36	32.27	10.67	33.56	100	230	P	H
	*	5700	95.35	-	-	85.97	32.27	10.67	33.56	100	230	A	H
		5725.24	61.45	-12.55	74	52.06	32.31	10.65	33.57	100	230	P	H
		5725.16	52.55	-1.45	54	43.16	32.31	10.65	33.57	100	230	A	H
													H
													H
	*	5700	105.1	-	-	95.72	32.27	10.67	33.56	348	101	P	V
	*	5700	97.11	-	-	87.73	32.27	10.67	33.56	348	101	A	V
		5725.96	63.29	-10.71	74	53.9	32.31	10.65	33.57	348	101	P	V
		5725	53.77	-0.23	54	44.38	32.31	10.65	33.57	348	101	A	V
													V
													V
Remark	1. No other spurious found. 2. All results are PASS against Peak and Average limit line.												



Band 3 - 5470~5725MHz

WIFI 802.11ac VHT20 (Harmonic @ 3m)

WIFI Ant. 1+2	Note	Frequency (MHz)	Level (dBµV/m)	Over Limit (dB)	Limit Line (dBµV/m)	Read Level (dBµV)	Antenna Factor (dB/m)	Cable Loss (dB)	Preamp Factor (dB)	Ant Pos (cm)	Table Pos (deg)	Peak Avg. (P/A)	Pol. (H/V)	
802.11ac VHT20 CH 100 5500MHz		11000	45.58	-28.42	74	57.01	40.3	15.27	67	100	0	P	H	
		16500	43.22	-25.08	68.3	50.03	38.9	18.29	64	100	0	P	H	
													H	
													H	
			11000	48.53	-25.47	74	59.96	40.3	15.27	67	100	0	P	V
			16500	47.62	-20.68	68.3	54.43	38.9	18.29	64	100	0	P	V
														V
802.11ac VHT20 CH 116 5580MHz		11160	47.23	-26.77	74	58.25	40.17	15.38	66.57	100	0	P	H	
		16740	38.32	-35.68	74	44.25	39.58	18.39	63.9	100	0	P	H	
													H	
													H	
			11160	47.8	-26.2	74	58.82	40.17	15.38	66.57	100	0	P	V
			16740	40.54	-33.46	74	46.47	39.58	18.39	63.9	100	0	P	V
														V
802.11ac VHT20 CH 140 5700MHz		11400	45.71	-28.29	74	56.16	39.98	15.53	65.96	100	0	P	H	
		17100	41.27	-32.73	74	46.06	40.6	18.53	63.92	100	0	P	H	
													H	
													H	
			11400	48.47	-25.53	74	58.92	39.98	15.53	65.96	100	0	P	V
			17100	42.25	-31.75	74	47.04	40.6	18.53	63.92	100	0	P	V
														V
Remark	1. No other spurious found.													
	2. All results are PASS against Peak and Average limit line.													



Band 3 - 5470~5725MHz

WIFI 802.11ac VHT40 (Band Edge @ 3m)

WIFI Ant. 1+2	Note	Frequency (MHz)	Level (dBμV/m)	Over Limit (dB)	Limit Line (dBμV/m)	Read Level (dBμV)	Antenna Factor (dB/m)	Cable Loss (dB)	Preamp Factor (dB)	Ant Pos (cm)	Table Pos (deg)	Peak Avg. (P/A)	Pol. (H/V)
802.11ac VHT40 CH 102 5510MHz		5455.76	57.69	-16.31	74	48.39	31.94	10.84	33.48	100	211	P	H
		5468.56	65.88	-2.42	68.3	56.59	31.96	10.81	33.48	100	211	P	H
		5459.01	53.22	-0.78	54	43.92	31.94	10.84	33.48	100	211	A	H
	*	5510	101.78	-	-	92.5	32	10.77	33.49	100	211	P	H
	*	5510	93.82	-	-	84.54	32	10.77	33.49	100	211	A	H
		5760.44	48.35	-19.95	68.3	38.94	32.36	10.63	33.58	100	211	P	H
		5458.8	58.96	-15.04	74	49.66	31.94	10.84	33.48	332	100	P	V
		5468.88	65.42	-2.88	68.3	56.13	31.96	10.81	33.48	332	100	P	V
		5459.34	53.17	-0.83	54	43.87	31.94	10.84	33.48	332	100	A	V
	*	5510	102.76	-	-	93.48	32	10.77	33.49	332	100	P	V
	*	5510	94.78	-	-	85.5	32	10.77	33.49	332	100	A	V
	5753	48.53	-19.77	68.3	39.11	32.36	10.63	33.57	332	100	P	V	
802.11ac VHT40 CH 110 5550MHz		5464.56	55.22	-18.78	74	45.93	31.96	10.81	33.48	100	213	P	H
		5468.08	42.14	-11.86	54	32.85	31.96	10.81	33.48	100	213	A	H
	*	5550	101.98	-	-	92.67	32.07	10.74	33.5	100	213	P	H
	*	5550	93.87	-	-	84.56	32.07	10.74	33.5	100	213	A	H
		5725	48.56	-25.44	74	39.17	32.31	10.65	33.57	100	213	P	H
		5744.52	40.23	-13.77	54	30.83	32.34	10.63	33.57	100	213	A	H
		5414	51.76	-22.24	74	42.47	31.9	10.87	33.48	367	101	P	V
		5469.68	42.37	-11.63	54	33.08	31.96	10.81	33.48	367	101	A	V
	*	5550	104.81	-	-	95.5	32.07	10.74	33.5	367	101	P	V
	*	5550	96.83	-	-	87.52	32.07	10.74	33.5	367	101	A	V
	5753.4	48.79	-25.21	74	39.37	32.36	10.63	33.57	367	101	P	V	
	5759.48	40.35	-13.65	54	30.94	32.36	10.63	33.58	367	101	A	V	



802.11ac VHT40 CH 134 5670MHz		5468.24	48.35	-25.65	74	39.06	31.96	10.81	33.48	100	212	P	H
		5450.64	40.07	-13.93	54	30.77	31.94	10.84	33.48	100	212	A	H
	*	5670	101.05	-	-	91.69	32.24	10.67	33.55	100	212	P	H
	*	5670	92.92	-	-	83.56	32.24	10.67	33.55	100	212	A	H
		5732.84	54.26	-19.74	74	44.87	32.31	10.65	33.57	100	212	P	H
		5725.24	47.06	-6.94	54	37.67	32.31	10.65	33.57	100	212	A	H
		5458.32	48.58	-25.42	74	39.28	31.94	10.84	33.48	333	103	P	V
		5464.56	40.13	-13.87	54	30.84	31.96	10.81	33.48	333	103	A	V
	*	5670	102.82	-	-	93.46	32.24	10.67	33.55	333	103	P	V
	*	5670	94.47	-	-	85.11	32.24	10.67	33.55	333	103	A	V
		5734.36	55.35	-18.65	74	45.96	32.31	10.65	33.57	333	103	P	V
		5725.48	48.29	-5.71	54	38.9	32.31	10.65	33.57	333	103	A	V
Remark	1. No other spurious found. 2. All results are PASS against Peak and Average limit line.												



Band 3 - 5470~5725MHz

WIFI 802.11ac VHT40 (Harmonic @ 3m)

WIFI Ant. 1+2	Note	Frequency (MHz)	Level (dBμV/m)	Over Limit (dB)	Limit Line (dBμV/m)	Read Level (dBμV)	Antenna Factor (dB/m)	Cable Loss (dB)	Preamp Factor (dB)	Ant Pos (cm)	Table Pos (deg)	Peak Avg. (P/A)	Pol. (H/V)	
802.11ac VHT40 CH 102 5510MHz		11020	43.43	-30.57	74	54.83	40.29	15.27	66.96	100	0	P	H	
		16530	38.32	-29.98	68.3	45	39	18.31	63.99	100	0	P	H	
													H	
													H	
			11020	45.63	-28.37	74	57.03	40.29	15.27	66.96	100	0	P	V
			16530	37.87	-30.43	68.3	44.55	39	18.31	63.99	100	0	P	V
														V
802.11ac VHT40 CH 110 5550MHz		11100	44.93	-29.07	74	56.12	40.22	15.33	66.74	100	0	P	H	
		16650	39.66	-34.34	74	45.91	39.33	18.36	63.94	100	0	P	H	
													H	
													H	
			11100	45.31	-28.69	74	56.5	40.22	15.33	66.74	100	0	P	V
			16650	39.43	-34.57	74	45.68	39.33	18.36	63.94	100	0	P	V
														V
802.11ac VHT40 CH 134 5670MHz		11340	46.14	-27.86	74	56.76	40.03	15.48	66.13	100	0	P	H	
		17010	40.57	-33.43	74	45.54	40.35	18.5	63.82	100	0	P	H	
													H	
													H	
			11340	47.89	-26.11	74	58.51	40.03	15.48	66.13	100	0	P	V
			17010	40.33	-33.67	74	45.3	40.35	18.5	63.82	100	0	P	V
														V
Remark	1. No other spurious found.													
	2. All results are PASS against Peak and Average limit line.													



Band 3 5470~5725MHz

WIFI 802.11ac VHT80 (Band Edge @ 3m)

WIFI Ant. 1+2	Note	Frequency (MHz)	Level (dBμV/m)	Over Limit (dB)	Limit Line (dBμV/m)	Read Level (dBμV)	Antenna Factor (dB/m)	Cable Loss (dB)	Preamp Factor (dB)	Ant Pos (cm)	Table Pos (deg)	Peak Avg. (P/A)	Pol. (H/V)
802.11ac VHT80 CH 106 5530MHz		5454.48	55.32	-18.68	74	46.02	31.94	10.84	33.48	100	213	P	H
		5466.8	55.51	-12.79	68.3	46.22	31.96	10.81	33.48	100	213	P	H
		5459.56	44.58	-9.42	54	35.28	31.94	10.84	33.48	100	213	A	H
	*	5530	94.89	-	-	85.6	32.02	10.77	33.5	100	213	P	H
	*	5530	86	-	-	76.71	32.02	10.77	33.5	100	213	A	H
		5756.92	48.65	-19.65	68.3	39.24	32.36	10.63	33.58	100	213	P	H
		5441.84	56.89	-17.11	74	47.61	31.92	10.84	33.48	353	102	P	V
		5469.68	57.11	-11.19	68.3	47.82	31.96	10.81	33.48	353	102	P	V
		5457.36	46.29	-7.71	54	36.99	31.94	10.84	33.48	353	102	A	V
	*	5530	97.55	-	-	88.26	32.02	10.77	33.5	353	102	P	V
	*	5530	89.61	-	-	80.32	32.02	10.77	33.5	353	102	A	V
	5753.16	47.78	-20.52	68.3	38.36	32.36	10.63	33.57	353	102	P	V	
802.11ac VHT80 CH 122 5610MHz		5464.24	54.65	-19.35	74	45.36	31.96	10.81	33.48	100	211	P	H
		5470	47.98	-6.02	54	38.69	31.96	10.81	33.48	100	211	A	H
	*	5610	97.97	-	-	88.65	32.14	10.71	33.53	100	211	P	H
	*	5610	90.52	-	-	81.2	32.14	10.71	33.53	100	211	A	H
		5853.68	49.45	-24.55	74	39.77	32.51	10.78	33.61	100	211	P	H
		5865.6	41.1	-12.9	54	31.27	32.51	10.94	33.62	100	211	A	H
		5466.64	56.39	-17.61	74	47.1	31.96	10.81	33.48	346	104	P	V
		5466.32	49.65	-4.35	54	40.36	31.96	10.81	33.48	346	104	A	V
	*	5610	98.87	-	-	89.55	32.14	10.71	33.53	346	104	P	V
	*	5610	91.04	-	-	81.72	32.14	10.71	33.53	346	104	A	V
		5885.52	49.45	-24.55	74	39.61	32.53	10.94	33.63	346	104	P	V
	5865.44	41.48	-12.52	54	31.65	32.51	10.94	33.62	346	104	A	V	
Remark	1. No other spurious found. 2. All results are PASS against Peak and Average limit line.												



Band 3 5470~5725MHz

WIFI 802.11ac VHT80 (Harmonic @ 3m)

WIFI Ant. 1+2	Note	Frequency (MHz)	Level (dBμV/m)	Over Limit (dB)	Limit Line (dBμV/m)	Read Level (dBμV)	Antenna Factor (dB/m)	Cable Loss (dB)	Preamp Factor (dB)	Ant Pos (cm)	Table Pos (deg)	Peak Avg. (P/A)	Pol. (H/V)	
802.11ac VHT80 CH 106 5530MHz		11060	42.28	-31.72	74	53.56	40.25	15.3	66.83	100	0	P	H	
		16590	37.81	-36.19	74	44.3	39.14	18.34	63.97	100	0	P	H	
													H	
													H	
			11060	42.72	-31.28	74	54	40.25	15.3	66.83	100	0	P	V
			16590	37.99	-36.01	74	44.48	39.14	18.34	63.97	100	0	P	V
														V
802.11ac VHT80 CH 122 5610MHz		11220	44.62	-29.38	74	55.53	40.13	15.4	66.44	100	0	P	H	
		16830	40.7	-33.3	74	46.31	39.82	18.44	63.87	100	0	P	H	
													H	
													H	
			11220	46.41	-27.59	74	57.32	40.13	15.4	66.44	100	0	P	V
			16830	41.1	-32.9	74	46.71	39.82	18.44	63.87	100	0	P	V
														V
Remark	1. No other spurious found.													
	2. All results are PASS against Peak and Average limit line.													



Band 3 - Straddle Channel

WIFI 802.11a (Band Edge @ 3m)

WIFI Ant. 1+2	Note	Frequency (MHz)	Level (dBµV/m)	Over Limit (dB)	Limit Line (dBµV/m)	Read Level (dBµV)	Antenna Factor (dB/m)	Cable Loss (dB)	Preamp Factor (dB)	Ant Pos (cm)	Table Pos (deg)	Peak Avg. (P/A)	Pol. (H/V)
802.11a CH 144 5720MHz	*	5720	104.4	-	-	95.01	32.31	10.65	33.57	100	209	P	H
	*	5720	97.3	-	-	87.91	32.31	10.65	33.57	100	209	A	H
													H
													H
													H
	*	5720	105.01	-	-	95.62	32.31	10.65	33.57	365	102	P	V
	*	5720	97.49	-	-	88.1	32.31	10.65	33.57	365	102	A	V
													V
													V
													V
Remark	1. No other spurious found. 2. All results are PASS against Peak and Average limit line.												

Band 3 - Straddle Channel

WIFI 802.11a (Harmonic @ 3m)

WIFI Ant. 1+2	Note	Frequency (MHz)	Level (dBµV/m)	Over Limit (dB)	Limit Line (dBµV/m)	Read Level (dBµV)	Antenna Factor (dB/m)	Cable Loss (dB)	Preamp Factor (dB)	Ant Pos (cm)	Table Pos (deg)	Peak Avg. (P/A)	Pol. (H/V)	
802.11a CH 144 5720MHz		11440	47.47	-26.53	74	57.83	39.95	15.56	65.87	100	0	P	H	
		17160	41.67	-32.33	74	46.3	40.8	18.57	64	100	0	P	H	
													H	
													H	
			11440	48.77	-25.23	74	59.13	39.95	15.56	65.87	100	0	P	V
			17160	44.56	-29.44	74	49.19	40.8	18.57	64	100	0	P	V
													V	
Remark	1. No other spurious found. 2. All results are PASS against Peak and Average limit line.													



Band 3 - Straddle Channel
WIFI 802.11n HT20 (Band Edge @ 3m)

WIFI Ant. 1+2	Note	Frequency (MHz)	Level (dBμV/m)	Over Limit (dB)	Limit Line (dBμV/m)	Read Level (dBμV)	Antenna Factor (dB/m)	Cable Loss (dB)	Preamp Factor (dB)	Ant Pos (cm)	Table Pos (deg)	Peak Avg. (P/A)	Pol. (H/V)
802.11n HT20 CH 144 5720MHz	*	5720	104.14	-	-	94.75	32.31	10.65	33.57	100	209	P	H
	*	5720	96.12	-	-	86.73	32.31	10.65	33.57	100	209	A	H
													H
													H
													H
													H
	*	5720	105.24	-	-	95.85	32.31	10.65	33.57	365	102	P	V
	*	5720	97.56	-	-	88.17	32.31	10.65	33.57	365	102	A	V
													V
													V
												V	
												V	
Remark	1. No other spurious found. 2. All results are PASS against Peak and Average limit line.												

Band 3 - Straddle Channel
WIFI 802.11n HT20 (Harmonic @ 3m)

WIFI Ant. 1+2	Note	Frequency (MHz)	Level (dBμV/m)	Over Limit (dB)	Limit Line (dBμV/m)	Read Level (dBμV)	Antenna Factor (dB/m)	Cable Loss (dB)	Preamp Factor (dB)	Ant Pos (cm)	Table Pos (deg)	Peak Avg. (P/A)	Pol. (H/V)	
802.11n HT20 CH 144 5720MHz		11440	46.42	-27.58	74	56.78	39.95	15.56	65.87	100	0	P	H	
		17160	40.55	-33.45	74	45.18	40.8	18.57	64	100	0	P	H	
													H	
													H	
			11440	48.04	-25.96	74	58.4	39.95	15.56	65.87	100	0	P	V
			17160	43.74	-30.26	74	48.37	40.8	18.57	64	100	0	P	V
													V	
												V		
Remark	1. No other spurious found. 2. All results are PASS against Peak and Average limit line.													



Band 3 - Straddle Channel
WIFI 802.11n HT40 (Band Edge @ 3m)

WIFI Ant. 1+2	Note	Frequency (MHz)	Level (dBμV/m)	Over Limit (dB)	Limit Line (dBμV/m)	Read Level (dBμV)	Antenna Factor (dB/m)	Cable Loss (dB)	Preamp Factor (dB)	Ant Pos (cm)	Table Pos (deg)	Peak Avg. (P/A)	Pol. (H/V)
802.11n HT40 CH 142 5710MHz	*	5710	102.03	-	-	92.66	32.29	10.65	33.57	100	213	P	H
	*	5710	93.89	-	-	84.52	32.29	10.65	33.57	100	213	A	H
													H
													H
													H
													H
	*	5710	103.6	-	-	94.23	32.29	10.65	33.57	348	103	P	V
	*	5710	95.45	-	-	86.08	32.29	10.65	33.57	348	103	A	V
													V
													V
Remark	1. No other spurious found. 2. All results are PASS against Peak and Average limit line.												

Band 3 - Straddle Channel
WIFI 802.11n HT40 (Harmonic @ 3m)

WIFI Ant. 1+2	Note	Frequency (MHz)	Level (dBμV/m)	Over Limit (dB)	Limit Line (dBμV/m)	Read Level (dBμV)	Antenna Factor (dB/m)	Cable Loss (dB)	Preamp Factor (dB)	Ant Pos (cm)	Table Pos (deg)	Peak Avg. (P/A)	Pol. (H/V)
802.11n HT40 CH 142 5710MHz		11420	43.58	-30.42	74	54	39.97	15.53	65.92	100	0	P	H
		17130	40.35	-33.65	74	45.06	40.7	18.55	63.96	100	0	P	H
													H
													H
													V
													V
													V
Remark	1. No other spurious found. 2. All results are PASS against Peak and Average limit line.												



Band 3 - Straddle Channel
WIFI 802.11ac VHT20 (Band Edge @ 3m)

WIFI Ant. 1+2	Note	Frequency (MHz)	Level (dBμV/m)	Over Limit (dB)	Limit Line (dBμV/m)	Read Level (dBμV)	Antenna Factor (dB/m)	Cable Loss (dB)	Preamp Factor (dB)	Ant Pos (cm)	Table Pos (deg)	Peak Avg. (P/A)	Pol. (H/V)
802.11ac VHT20 CH 144 5720MHz	*	5720	105.07	-	-	95.68	32.31	10.65	33.57	105	233	P	H
	*	5720	97.35	-	-	87.96	32.31	10.65	33.57	105	233	A	H
													H
													H
													H
													H
	*	5720	106.32	-	-	96.93	32.31	10.65	33.57	363	103	P	V
	*	5720	97.64	-	-	88.25	32.31	10.65	33.57	363	103	A	V
													V
													V
												V	
												V	
Remark	1. No other spurious found. 2. All results are PASS against Peak and Average limit line.												

Band 3 - Straddle Channel
WIFI 802.11ac VHT20 (Harmonic @ 3m)

WIFI Ant. 1+2	Note	Frequency (MHz)	Level (dBμV/m)	Over Limit (dB)	Limit Line (dBμV/m)	Read Level (dBμV)	Antenna Factor (dB/m)	Cable Loss (dB)	Preamp Factor (dB)	Ant Pos (cm)	Table Pos (deg)	Peak Avg. (P/A)	Pol. (H/V)
802.11ac VHT20 CH 144 5720MHz		11440	46.45	-27.55	74	56.81	39.95	15.56	65.87	100	0	P	H
		17160	41.37	-32.63	74	46	40.8	18.57	64	100	0	P	H
													H
													H
													V
													V
													V
Remark	1. No other spurious found. 2. All results are PASS against Peak and Average limit line.												



Band 3 - Straddle Channel
WIFI 802.11ac VHT40 (Band Edge @ 3m)

WIFI Ant. 1+2	Note	Frequency (MHz)	Level (dBµV/m)	Over Limit (dB)	Limit Line (dBµV/m)	Read Level (dBµV)	Antenna Factor (dB/m)	Cable Loss (dB)	Preamp Factor (dB)	Ant Pos (cm)	Table Pos (deg)	Peak Avg. (P/A)	Pol. (H/V)
802.11ac VHT40 CH 142 5710MHz	*	5710	101.99	-	-	92.62	32.29	10.65	33.57	100	212	P	H
	*	5710	93.03	-	-	83.66	32.29	10.65	33.57	100	212	A	H
													H
													H
													H
													H
	*	5710	103.01	-	-	93.64	32.29	10.65	33.57	366	100	P	V
	*	5710	95.48	-	-	86.11	32.29	10.65	33.57	366	100	A	V
													V
													V
												V	
												V	
Remark	1. No other spurious found. 2. All results are PASS against Peak and Average limit line.												

Band 3 - Straddle Channel
WIFI 802.11ac VHT40 (Harmonic @ 3m)

WIFI Ant. 1+2	Note	Frequency (MHz)	Level (dBµV/m)	Over Limit (dB)	Limit Line (dBµV/m)	Read Level (dBµV)	Antenna Factor (dB/m)	Cable Loss (dB)	Preamp Factor (dB)	Ant Pos (cm)	Table Pos (deg)	Peak Avg. (P/A)	Pol. (H/V)	
802.11ac VHT40 CH 142 5710MHz		11420	43.72	-30.28	74	54.14	39.97	15.53	65.92	100	0	P	H	
		17130	40.42	-33.58	74	45.13	40.7	18.55	63.96	100	0	P	H	
													H	
													H	
			11420	45.06	-28.94	74	55.48	39.97	15.53	65.92	100	0	P	V
			17130	41.52	-32.48	74	46.23	40.7	18.55	63.96	100	0	P	V
													V	
												V		
Remark	1. No other spurious found. 2. All results are PASS against Peak and Average limit line.													



Emission below 1GHz

WIFI 802.11ac VHT20 (LF @ 3m)

WIFI	Note	Frequency	Level	Over	Limit	Read	Antenna	Cable	Preamp	Ant	Table	Peak	Pol.	
Ant.				Limit	Line	Level	Factor	Loss	Factor	Pos	Pos	Avg.		
1+2		(MHz)	(dBμV/m)	(dB)	(dBμV/m)	(dBμV)	(dB/m)	(dB)	(dB)	(cm)	(deg)	(P/A)	(H/V)	
802.11ac VHT20 LF		121.53	37.98	-5.52	43.5	50.55	17.73	1.48	31.78	110	287	P	H	
		213.87	30.87	-12.63	43.5	44.71	16.2	1.74	31.78	-	-	P	H	
		294.06	30.05	-15.95	46	40.1	19.58	2.13	31.76	-	-	P	H	
		304.2	27.3	-18.7	46	37	19.83	2.23	31.76	-	-	P	H	
		437.9	26.69	-19.31	46	31.75	23.09	3.68	31.83	-	-	P	H	
		737.5	29.37	-16.63	46	30.38	27.45	3.54	32	-	-	P	H	
														H
														H
														H
														H
														H
														H
			30	35.88	-4.12	40	41.08	25.7	0.93	31.83	291	75	P	V
			80.76	29.58	-10.42	40	46.5	13.7	1.17	31.79	-	-	P	V
			119.1	34.65	-8.85	43.5	47.3	17.65	1.48	31.78	-	-	P	V
			311.9	25.01	-20.99	46	34.49	20.05	2.23	31.76	-	-	P	V
			612.9	27.65	-18.35	46	30.7	25.83	3.16	32.04	-	-	P	V
			841.1	31.49	-14.51	46	30.65	28.79	3.77	31.72	-	-	P	V
														V
														V
													V	
													V	
													V	
													V	
Remark	1. No other spurious found. 2. All results are PASS against limit line.													



Note symbol

*	Fundamental Frequency which can be ignored. However, the level of any unwanted emissions shall not exceed the level of the fundamental frequency.
!	Test result is over limit line.
P/A	Peak or Average
H/V	Horizontal or Vertical



A calculation example for radiated spurious emission is shown as below:

WIFI	Note	Frequency	Level	Over	Limit	Read	Antenna	Cable	Preamp	Ant	Table	Peak	Pol.
Ant.				Limit	Line	Level	Factor	Loss	Factor	Pos	Pos	Avg.	
1+2		(MHz)	(dBμV/m)	(dB)	(dBμV/m)	(dBμV)	(dB/m)	(dB)	(dB)	(cm)	(deg)	(P/A)	(H/V)
802.11b		2390	55.45	-18.55	74	54.51	32.22	4.58	35.86	103	308	P	H
CH 01													
2412MHz		2390	43.54	-10.46	54	42.6	32.22	4.58	35.86	103	308	A	H

- Level(dBμV/m) =
Antenna Factor(dB/m) + Cable Loss(dB) + Read Level(dBμV) - Preamp Factor(dB)
- Over Limit(dB) = Level(dBμV/m) – Limit Line(dBμV/m)

For Peak Limit @ 2390MHz:

- Level(dBμV/m)
= Antenna Factor(dB/m) + Cable Loss(dB) + Read Level(dBμV) - Preamp Factor(dB)
= 32.22(dB/m) + 4.58(dB) + 54.51(dBμV) – 35.86 (dB)
= 55.45 (dBμV/m)
- Over Limit(dB)
= Level(dBμV/m) – Limit Line(dBμV/m)
= 55.45(dBμV/m) – 74(dBμV/m)
= -18.55(dB)

For Average Limit @ 2390MHz:

- Level(dBμV/m)
= Antenna Factor(dB/m) + Cable Loss(dB) + Read Level(dBμV) - Preamp Factor(dB)
= 32.22(dB/m) + 4.58(dB) + 42.6(dBμV) – 35.86 (dB)
= 43.54 (dBμV/m)
- Over Limit(dB)
= Level(dBμV/m) – Limit Line(dBμV/m)
= 43.54(dBμV/m) – 54(dBμV/m)
= -10.46(dB)

Both peak and average measured complies with the limit line, so test result is “PASS”.



Appendix C. Radiated Spurious Emission Plots

Test Engineer :	J.C. Liang, Bill Chang, and Ken Wu	Temperature :	19~21°C
		Relative Humidity :	50~55%

Note symbol

-L	Low channel location
-R	High channel location

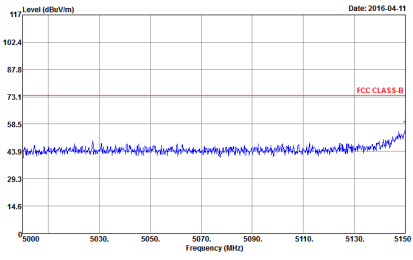
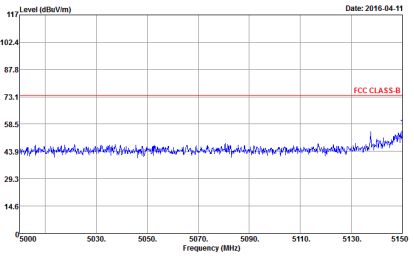
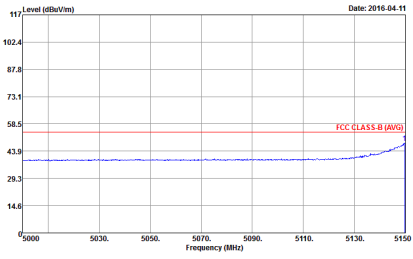
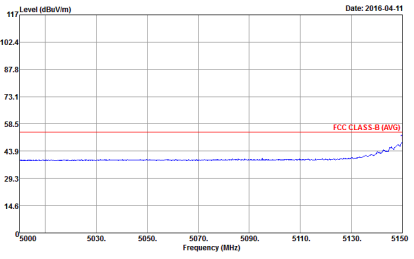

Band 1 - 5150~5250MHz
WIFI 802.11a (Band Edge @ 3m)

WIFI	Band 1 5150~5250MHz Band Edge @ 3m	
ANT	802.11a CH36 5180MHz	
1+2	Horizontal	Vertical
Peak	 <p>Site : 03CH11-HY Condition : FCC CLASS-B 3m HORN 9120D-HF HORIZONTAL RBW:1000.000KHz VBW:3000.000KHz SWT:Auto Detector : Peak Project : 631828 Mode : 1</p>	 <p>Site : 03CH11-HY Condition : FCC CLASS-B 3m HORN 9120D-HF VERTICAL RBW:1000.000KHz VBW:3000.000KHz SWT:Auto Detector : Peak Project : 631828 Mode : 1</p>
Avg.	 <p>Site : 03CH11-HY Condition : FCC CLASS-B (AVG) 3m HORN 9120D-HF HORIZONTAL RBW:1000.000KHz VBW:1000KHz SWT:Auto Detector : Peak Project : 631828 Mode : 1</p>	 <p>Site : 03CH11-HY Condition : FCC CLASS-B (AVG) 3m HORN 9120D-HF VERTICAL RBW:1000.000KHz VBW:1000KHz SWT:Auto Detector : Peak Project : 631828 Mode : 1</p>

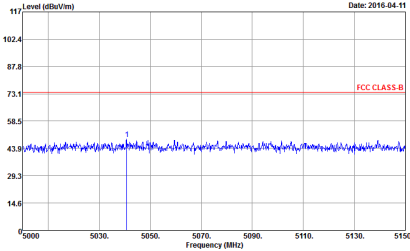
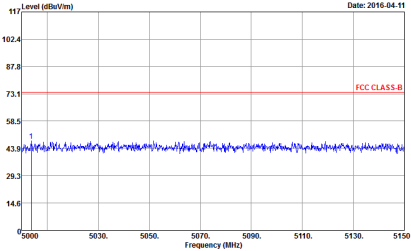
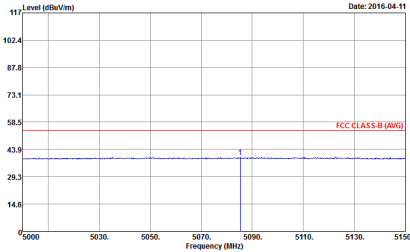
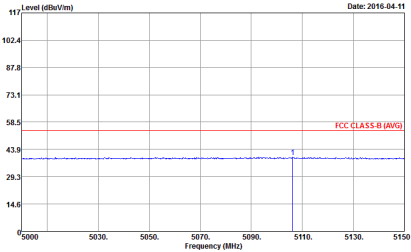

WIFI	Band 1 5150~5250MHz Band Edge @ 3m	
ANT	802.11a CH44 5220MHz - L	
1+2	Horizontal	Vertical
Peak	 <p>Date: 2016-04-11</p> <p>Site : 03CH11-HY Condition : FCC CLASS-B 3m HORN 9120D-HF HORIZONTAL RBW:1000.000KHz VBW:3000.000KHz SWT:Auto Detector : Peak Project : 631828 Mode : 2</p>	 <p>Date: 2016-04-11</p> <p>Site : 03CH11-HY Condition : FCC CLASS-B 3m HORN 9120D-HF VERTICAL RBW:1000.000KHz VBW:3000.000KHz SWT:Auto Detector : Peak Project : 631828 Mode : 2</p>
Avg.	 <p>Date: 2016-04-11</p> <p>Site : 03CH11-HY Condition : FCC CLASS-B (AVG) 3m HORN 9120D-HF HORIZONTAL RBW:1000.000KHz VBW:1000KHz SWT:Auto Detector : Peak Project : 631828 Mode : 2</p>	 <p>Date: 2016-04-11</p> <p>Site : 03CH11-HY Condition : FCC CLASS-B (AVG) 3m HORN 9120D-HF VERTICAL RBW:1000.000KHz VBW:1000KHz SWT:Auto Detector : Peak Project : 631828 Mode : 2</p>

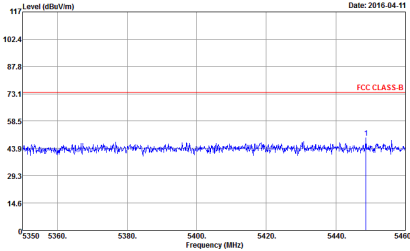
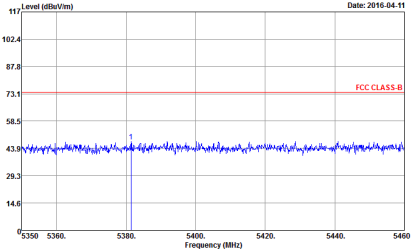
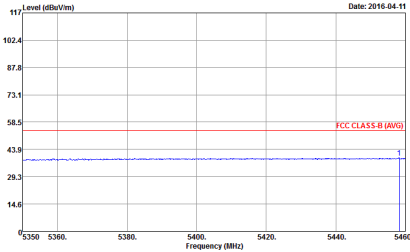
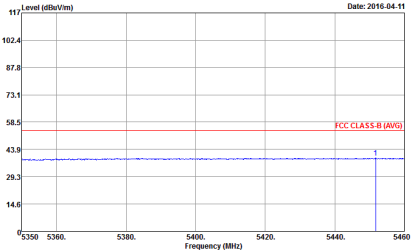

WIFI	Band 1 5150~5250MHz Band Edge @ 3m	
ANT	802.11a CH44 5220MHz - R	
1+2	Horizontal	Vertical
Peak	 <p>Date: 2016-04-11</p> <p>Site : 03CH11-HY Condition : FCC CLASS-B 3m HORN 9120D-HF HORIZONTAL RBW:1000.000KHz VBW:3000.000KHz SWT:Auto Detector : Peak Project : 631828 Mode : 2</p>	 <p>Date: 2016-04-11</p> <p>Site : 03CH11-HY Condition : FCC CLASS-B 3m HORN 9120D-HF VERTICAL RBW:1000.000KHz VBW:3000.000KHz SWT:Auto Detector : Peak Project : 631828 Mode : 2</p>
Avg.	 <p>Date: 2016-04-11</p> <p>Site : 03CH11-HY Condition : FCC CLASS-B (AVG) 3m HORN 9120D-HF HORIZONTAL RBW:1000.000KHz VBW:1000KHz SWT:Auto Detector : Peak Project : 631828 Mode : 2</p>	 <p>Date: 2016-04-11</p> <p>Site : 03CH11-HY Condition : FCC CLASS-B (AVG) 3m HORN 9120D-HF VERTICAL RBW:1000.000KHz VBW:1000KHz SWT:Auto Detector : Peak Project : 631828 Mode : 2</p>

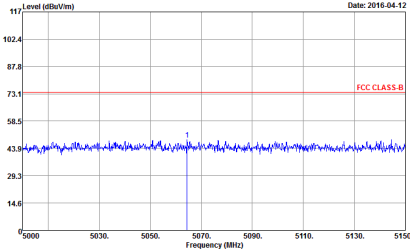
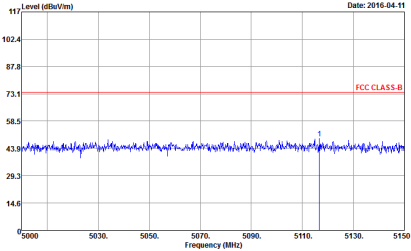
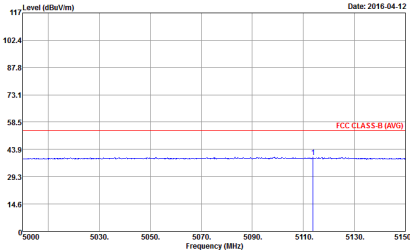
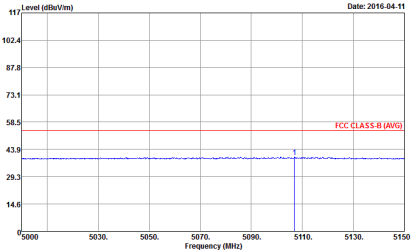

WIFI	Band 1 5150~5250MHz Band Edge @ 3m	
ANT	802.11a CH48 5240MHz - L	
1+2	Horizontal	Vertical
Peak	 <p>Date: 2016-04-12</p> <p>Site : 03CH11-HY Condition : FCC CLASS-B 3m HORN 9120D-HF HORIZONTAL RBW:1000.000KHz VBW:3000.000KHz SWT:Auto Detector : Peak Project : 631828 Mode : 3</p>	 <p>Date: 2016-04-11</p> <p>Site : 03CH11-HY Condition : FCC CLASS-B 3m HORN 9120D-HF VERTICAL RBW:1000.000KHz VBW:3000.000KHz SWT:Auto Detector : Peak Project : 631828 Mode : 3</p>
Avg.	 <p>Date: 2016-04-12</p> <p>Site : 03CH11-HY Condition : FCC CLASS-B (AVG) 3m HORN 9120D-HF HORIZONTAL RBW:1000.000KHz VBW:1000KHz SWT:Auto Detector : Peak Project : 631828 Mode : 3</p>	 <p>Date: 2016-04-11</p> <p>Site : 03CH11-HY Condition : FCC CLASS-B (AVG) 3m HORN 9120D-HF VERTICAL RBW:1000.000KHz VBW:1000KHz SWT:Auto Detector : Peak Project : 631828 Mode : 3</p>

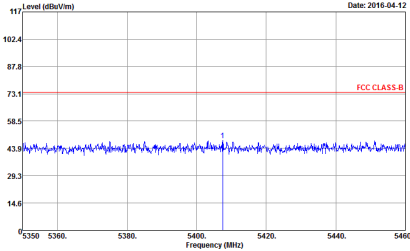
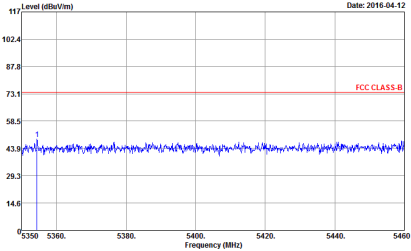
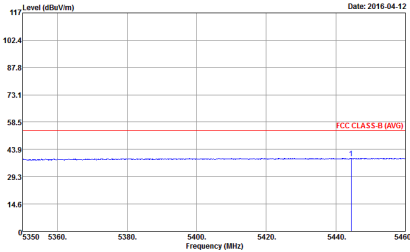
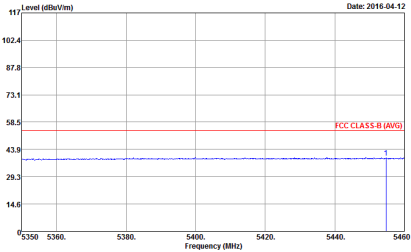

WIFI	Band 1 5150~5250MHz Band Edge @ 3m	
ANT	802.11a CH48 5240MHz - R	
1+2	Horizontal	Vertical
Peak	 <p>Date: 2016-04-12</p> <p>Site : 03CH11-HY Condition : FCC CLASS-B 3m HORN 9120D-HF HORIZONTAL RBW:1000.000KHz VBW:3000.000KHz SWT:Auto Detector : Peak Project : 631828 Mode : 3</p>	 <p>Date: 2016-04-12</p> <p>Site : 03CH11-HY Condition : FCC CLASS-B 3m HORN 9120D-HF VERTICAL RBW:1000.000KHz VBW:3000.000KHz SWT:Auto Detector : Peak Project : 631828 Mode : 3</p>
Avg.	 <p>Date: 2016-04-12</p> <p>Site : 03CH11-HY Condition : FCC CLASS-B (AVG) 3m HORN 9120D-HF HORIZONTAL RBW:1000.000KHz VBW:1.000KHz SWT:Auto Detector : Peak Project : 631828 Mode : 3</p>	 <p>Date: 2016-04-12</p> <p>Site : 03CH11-HY Condition : FCC CLASS-B (AVG) 3m HORN 9120D-HF VERTICAL RBW:1000.000KHz VBW:1.000KHz SWT:Auto Detector : Peak Project : 631828 Mode : 3</p>

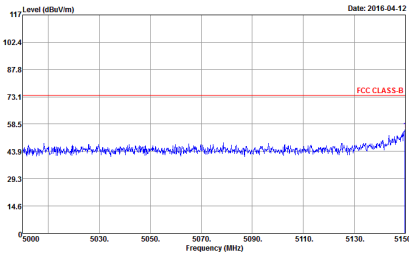
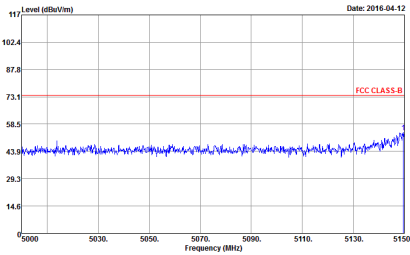
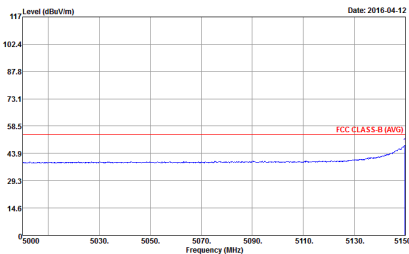
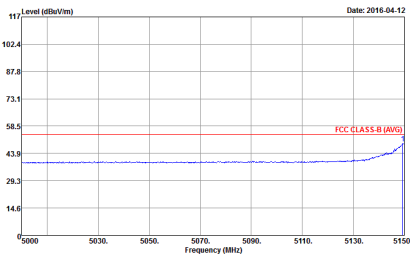

Band 1 5150~5250MHz
WIFI 802.11n HT20 (Band Edge @ 3m)

WIFI	Band 1 5150~5250MHz Band Edge @ 3m	
ANT	802.11n HT20 CH36 5180MHz	
1+2	Horizontal	Vertical
<p>Peak</p>	 <p>Site : 03CH11-HY Condition : FCC CLASS-B 3m HORN 9120D-HF HORIZONTAL Detector : Peak Project : 631828 Mode : IO</p>	 <p>Site : 03CH11-HY Condition : FCC CLASS-B 3m HORN 9120D-HF VERTICAL Detector : Peak Project : 631828 Mode : IO</p>
<p>Avg.</p>	 <p>Site : 03CH11-HY Condition : FCC CLASS-B (AVG) 3m HORN 9120D-HF HORIZONTAL Detector : Peak Project : 631828 Mode : IO</p>	 <p>Site : 03CH11-HY Condition : FCC CLASS-B (AVG) 3m HORN 9120D-HF VERTICAL Detector : Peak Project : 631828 Mode : IO</p>

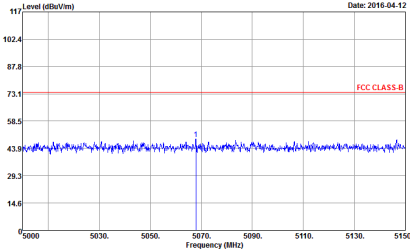
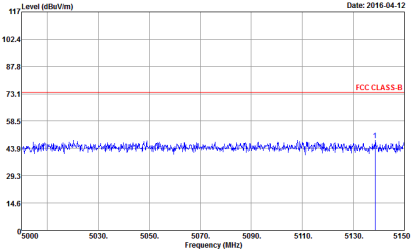
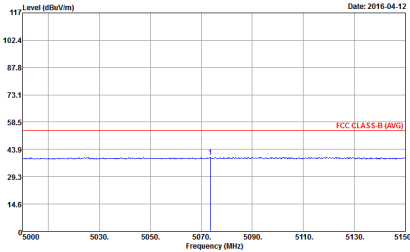
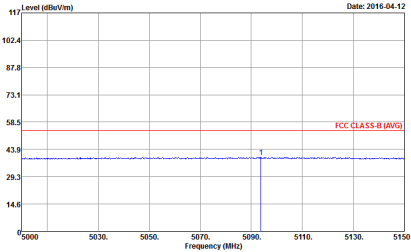

WIFI	Band 1 5150~5250MHz Band Edge @ 3m	
ANT	802.11n HT20 CH44 5220MHz - L	
1+2	Horizontal	Vertical
Peak	 <p>Date: 2016-04-12</p> <p>Site : 03CH11-HY Condition : FCC CLASS-B 3m HORN 9120D-HF HORIZONTAL RBW:1000.000KHz VBW:3000.000KHz SWT:Auto Detector : Peak Project : 631828 Mode : II</p>	 <p>Date: 2016-04-12</p> <p>Site : 03CH11-HY Condition : FCC CLASS-B 3m HORN 9120D-HF VERTICAL RBW:1000.000KHz VBW:3000.000KHz SWT:Auto Detector : Peak Project : 631828 Mode : II</p>
Avg.	 <p>Date: 2016-04-12</p> <p>Site : 03CH11-HY Condition : FCC CLASS-B (AVG) 3m HORN 9120D-HF HORIZONTAL RBW:1000.000KHz VBW:1000KHz SWT:Auto Detector : Peak Project : 631828 Mode : II</p>	 <p>Date: 2016-04-12</p> <p>Site : 03CH11-HY Condition : FCC CLASS-B (AVG) 3m HORN 9120D-HF VERTICAL RBW:1000.000KHz VBW:1000KHz SWT:Auto Detector : Peak Project : 631828 Mode : II</p>

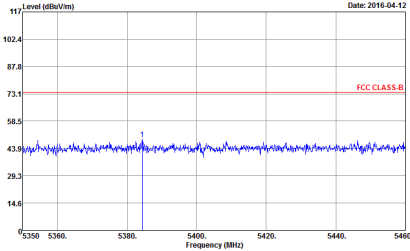
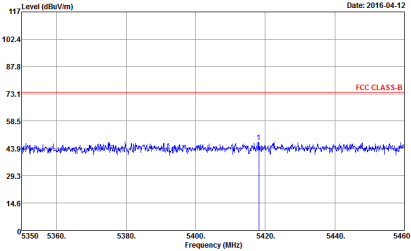
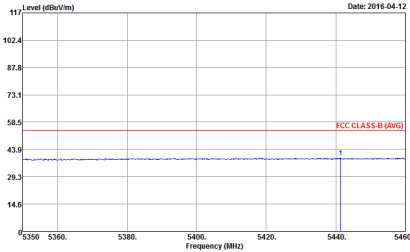
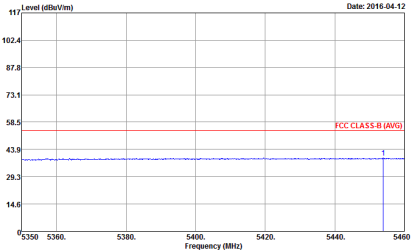

WIFI	Band 1 5150~5250MHz Band Edge @ 3m	
ANT	802.11n HT20 CH44 5220MHz - R	
1+2	Horizontal	Vertical
Peak	 <p>Date: 2016-04-12</p> <p>Site : 03CH11-HY Condition : FCC CLASS-B 3m HORN 9120D-HF HORIZONTAL RBW:1000.000KHz VBW:3000.000KHz SWT:Auto Detector : Peak Project : 631828 Mode : II</p>	 <p>Date: 2016-04-12</p> <p>Site : 03CH11-HY Condition : FCC CLASS-B 3m HORN 9120D-HF VERTICAL RBW:1000.000KHz VBW:3000.000KHz SWT:Auto Detector : Peak Project : 631828 Mode : II</p>
Avg.	 <p>Date: 2016-04-12</p> <p>Site : 03CH11-HY Condition : FCC CLASS-B (AVG) 3m HORN 9120D-HF HORIZONTAL RBW:1000.000KHz VBW:1000KHz SWT:Auto Detector : Peak Project : 631828 Mode : II</p>	 <p>Date: 2016-04-12</p> <p>Site : 03CH11-HY Condition : FCC CLASS-B (AVG) 3m HORN 9120D-HF VERTICAL RBW:1000.000KHz VBW:1000KHz SWT:Auto Detector : Peak Project : 631828 Mode : II</p>

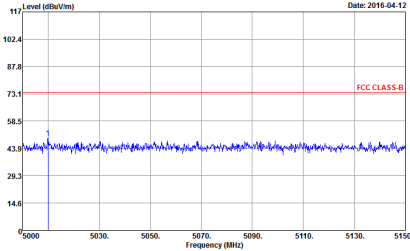
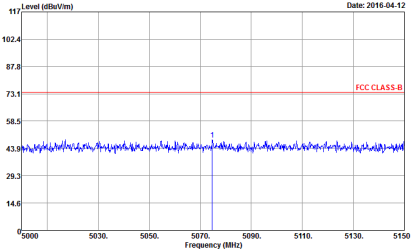
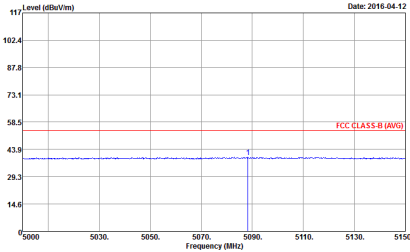
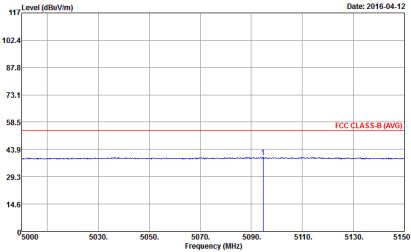

WIFI	Band 1 5150~5250MHz Band Edge @ 3m	
ANT	802.11n HT20 CH48 5240MHz - L	
1+2	Horizontal	Vertical
Peak	 <p>Date: 2016-04-12</p> <p>Site : 03CH11-HY Condition : FCC CLASS-B 3m HORN 9120D-HF HORIZONTAL Detector : Peak Project : 631828 Mode : 12</p>	 <p>Date: 2016-04-12</p> <p>Site : 03CH11-HY Condition : FCC CLASS-B 3m HORN 9120D-HF VERTICAL Detector : Peak Project : 631828 Mode : 12</p>
Avg.	 <p>Date: 2016-04-12</p> <p>Site : 03CH11-HY Condition : FCC CLASS-B (AVG) 3m HORN 9120D-HF HORIZONTAL Detector : Peak Project : 631828 Mode : 12</p>	 <p>Date: 2016-04-12</p> <p>Site : 03CH11-HY Condition : FCC CLASS-B (AVG) 3m HORN 9120D-HF VERTICAL Detector : Peak Project : 631828 Mode : 12</p>

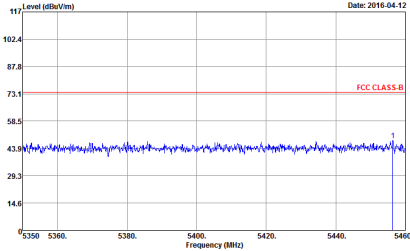
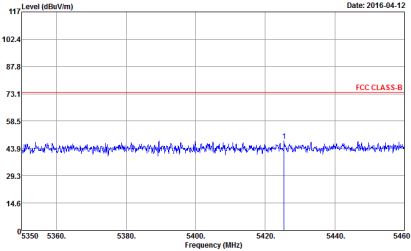
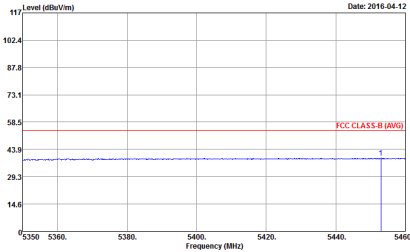
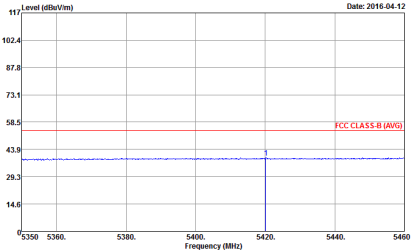

WIFI	Band 1 5150~5250MHz Band Edge @ 3m	
ANT	802.11n HT20 CH48 5240MHz - R	
1+2	Horizontal	Vertical
Peak	 <p>Date: 2016-04-12</p> <p>Site : 03CH11-HY Condition : FCC CLASS-B 3m HORN 9120D-HF HORIZONTAL RBW:1000.000KHz VBW:3000.000KHz SWT:Auto Detector : Peak Project : 631828 Mode : 12</p>	 <p>Date: 2016-04-12</p> <p>Site : 03CH11-HY Condition : FCC CLASS-B 3m HORN 9120D-HF VERTICAL RBW:1000.000KHz VBW:3000.000KHz SWT:Auto Detector : Peak Project : 631828 Mode : 12</p>
Avg.	 <p>Date: 2016-04-12</p> <p>Site : 03CH11-HY Condition : FCC CLASS-B (AVG) 3m HORN 9120D-HF HORIZONTAL RBW:1000.000KHz VBW:1.000KHz SWT:Auto Detector : Peak Project : 631828 Mode : 12</p>	 <p>Date: 2016-04-12</p> <p>Site : 03CH11-HY Condition : FCC CLASS-B (AVG) 3m HORN 9120D-HF VERTICAL RBW:1000.000KHz VBW:1.000KHz SWT:Auto Detector : Peak Project : 631828 Mode : 12</p>

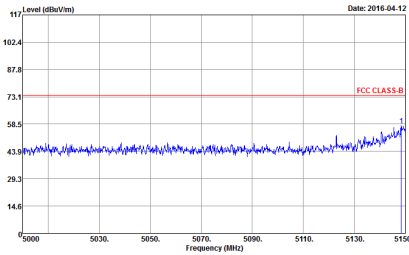
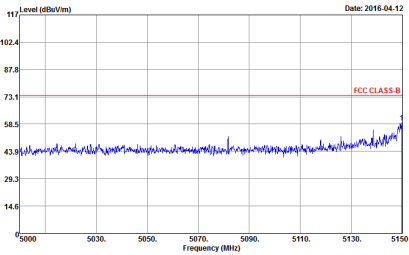
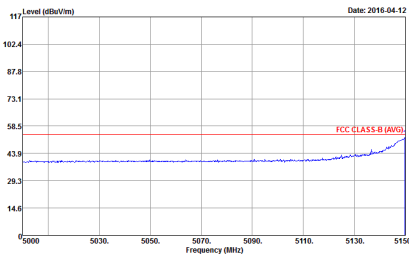
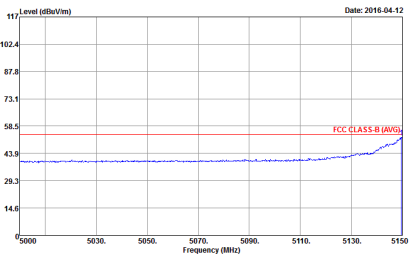

**Band 1 5150~5250MHz
WIFI 802.11n HT40 (Band Edge @ 3m)**

WIFI	Band 1 5150~5250MHz Band Edge @ 3m	
ANT	802.11n HT40 CH38 5190MHz - L	
1+2	Horizontal	Vertical
Peak	 <p>Site : 03CH11-HY Condition : FCC CLASS-B 3m HORN 9120D-HF HORIZONTAL Detector : Peak Project : 631828 Mode : 19 Setting : 14.5</p>	 <p>Site : 03CH11-HY Condition : FCC CLASS-B 3m HORN 9120D-HF VERTICAL Detector : Peak Project : 631828 Mode : 19 Setting : 14.5</p>
Avg.	 <p>Site : 03CH11-HY Condition : FCC CLASS-B (AVG) 3m HORN 9120D-HF HORIZONTAL Detector : Peak Project : 631828 Mode : 19 Setting : 14.5</p>	 <p>Site : 03CH11-HY Condition : FCC CLASS-B (AVG) 3m HORN 9120D-HF VERTICAL Detector : Peak Project : 631828 Mode : 19 Setting : 14.5</p>

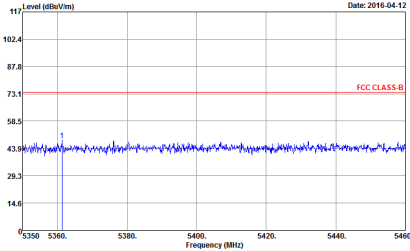
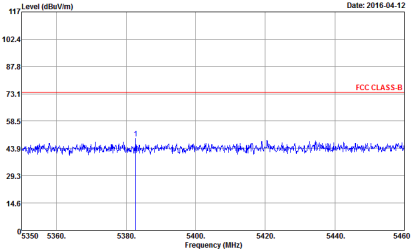
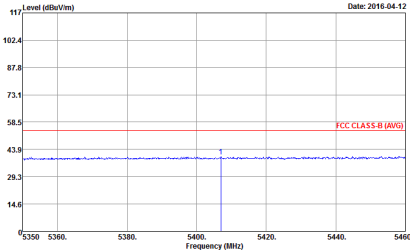
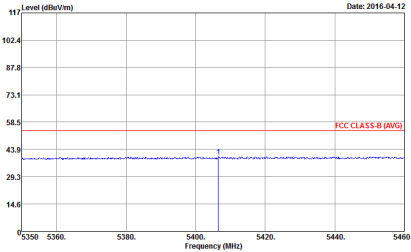

WIFI	Band 1 5150~5250MHz Band Edge @ 3m	
ANT	802.11n HT40 CH38 5190MHz - R	
1+2	Horizontal	Vertical
Peak	 <p>Date: 2016-04-12</p> <p>Site : 03CH11-HY Condition : FCC CLASS-B 3m HORN 9120D-HF HORIZONTAL RBW:1000.000KHz VBW:3000.000KHz SWT:Auto Detector : Peak Project : 631828 Mode : 19 Setting : 14.5</p>	 <p>Date: 2016-04-12</p> <p>Site : 03CH11-HY Condition : FCC CLASS-B 3m HORN 9120D-HF VERTICAL RBW:1000.000KHz VBW:3000.000KHz SWT:Auto Detector : Peak Project : 631828 Mode : 19 Setting : 14.5</p>
Avg.	 <p>Date: 2016-04-12</p> <p>Site : 03CH11-HY Condition : FCC CLASS-B (AVG) 3m HORN 9120D-HF HORIZONTAL RBW:1000.000KHz VBW:3.000KHz SWT:Auto Detector : Peak Project : 631828 Mode : 19 Setting : 14.5</p>	 <p>Date: 2016-04-12</p> <p>Site : 03CH11-HY Condition : FCC CLASS-B (AVG) 3m HORN 9120D-HF VERTICAL RBW:1000.000KHz VBW:3.000KHz SWT:Auto Detector : Peak Project : 631828 Mode : 19 Setting : 14.5</p>

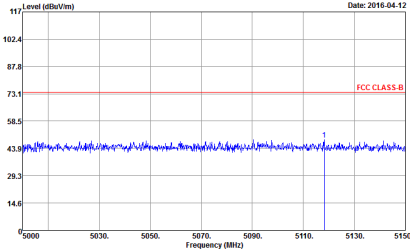
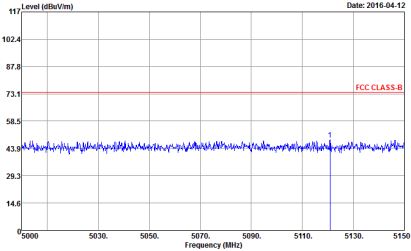
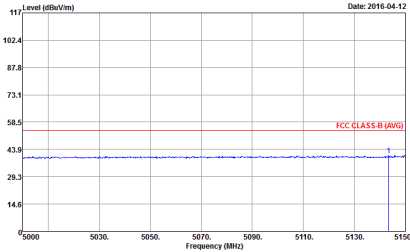
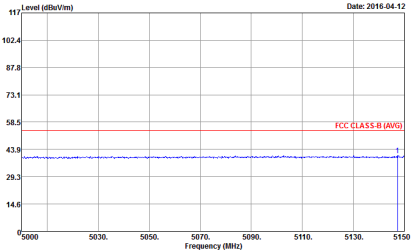

WIFI	Band 1 5150~5250MHz Band Edge @ 3m	
ANT	802.11n HT40 CH46 5230MHz - L	
1+2	Horizontal	Vertical
Peak	 <p>Date: 2016-04-12</p> <p>Site : 03CH11-HY Condition : FCC CLASS-B 3m HORN 9120D-HF HORIZONTAL RBW:1000.000KHz VBW:3000.000KHz SWT:Auto Detector : Peak Project : 631828 Mode : 20</p>	 <p>Date: 2016-04-12</p> <p>Site : 03CH11-HY Condition : FCC CLASS-B 3m HORN 9120D-HF VERTICAL RBW:1000.000KHz VBW:3000.000KHz SWT:Auto Detector : Peak Project : 631828 Mode : 20</p>
Avg.	 <p>Date: 2016-04-12</p> <p>Site : 03CH11-HY Condition : FCC CLASS-B (AVG) 3m HORN 9120D-HF HORIZONTAL RBW:1000.000KHz VBW:3.000KHz SWT:Auto Detector : Peak Project : 631828 Mode : 20</p>	 <p>Date: 2016-04-12</p> <p>Site : 03CH11-HY Condition : FCC CLASS-B (AVG) 3m HORN 9120D-HF VERTICAL RBW:1000.000KHz VBW:3.000KHz SWT:Auto Detector : Peak Project : 631828 Mode : 20</p>

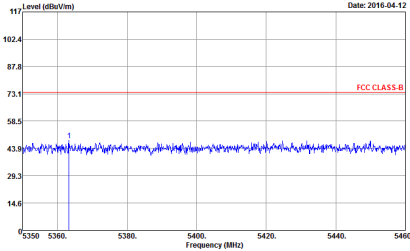
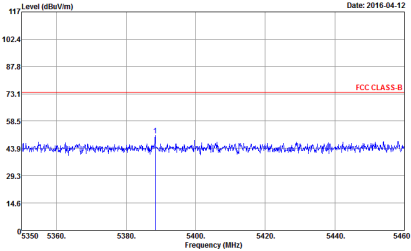
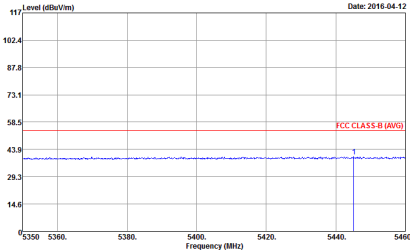
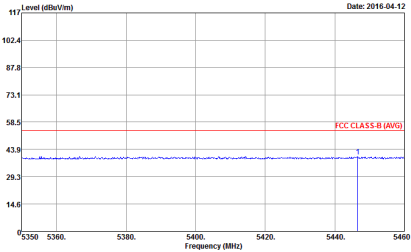

WIFI	Band 1 5150~5250MHz Band Edge @ 3m	
ANT	802.11n HT40 CH46 5230MHz - R	
1+2	Horizontal	Vertical
Peak	 <p>Date: 2016-04-12</p> <p>Site : 03CH11-HY Condition : FCC CLASS-B 3m HORN 9120D-HF HORIZONTAL RBW:1000.000KHz VBW:3000.000KHz SWT:Auto Detector : Peak Project : 631828 Mode : 20</p>	 <p>Date: 2016-04-12</p> <p>Site : 03CH11-HY Condition : FCC CLASS-B 3m HORN 9120D-HF VERTICAL RBW:1000.000KHz VBW:3000.000KHz SWT:Auto Detector : Peak Project : 631828 Mode : 20</p>
Avg.	 <p>Date: 2016-04-12</p> <p>Site : 03CH11-HY Condition : FCC CLASS-B (AVG) 3m HORN 9120D-HF HORIZONTAL RBW:1000.000KHz VBW:3.000KHz SWT:Auto Detector : Peak Project : 631828 Mode : 20</p>	 <p>Date: 2016-04-12</p> <p>Site : 03CH11-HY Condition : FCC CLASS-B (AVG) 3m HORN 9120D-HF VERTICAL RBW:1000.000KHz VBW:3.000KHz SWT:Auto Detector : Peak Project : 631828 Mode : 20</p>

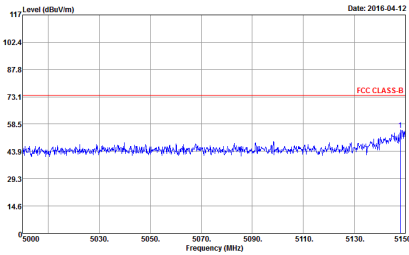
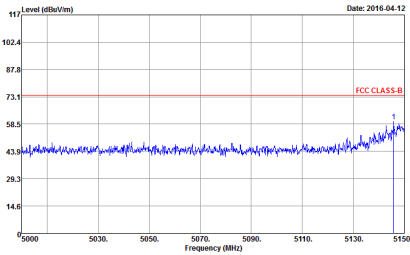
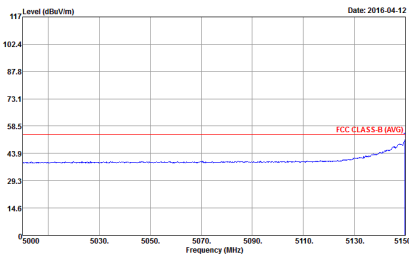
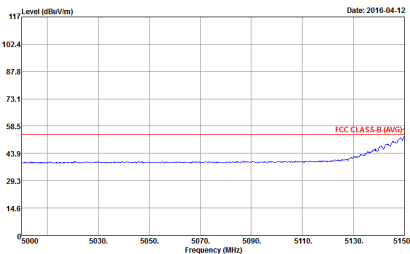

Band 1 5150~5250MHz
WIFI 802.11ac VHT20 (Band Edge @ 3m)

WIFI	Band 1 5150~5250MHz Band Edge @ 3m	
ANT	802.11ac VHT20 CH36 5180MHz	
1+2	Horizontal	Vertical
Peak	 <p>Site : 03CH11-HY Condition : FCC CLASS-B 3m HORN 9120D-HF HORIZONTAL Detector : Peak Project : 631828 Mode : 26</p>	 <p>Site : 03CH11-HY Condition : FCC CLASS-B 3m HORN 9120D-HF VERTICAL Detector : Peak Project : 631828 Mode : 26</p>
Avg.	 <p>Site : 03CH11-HY Condition : FCC CLASS-B (AVG) 3m HORN 9120D-HF HORIZONTAL Detector : Peak Project : 631828 Mode : 26</p>	 <p>Site : 03CH11-HY Condition : FCC CLASS-B (AVG) 3m HORN 9120D-HF VERTICAL Detector : Peak Project : 631828 Mode : 26</p>

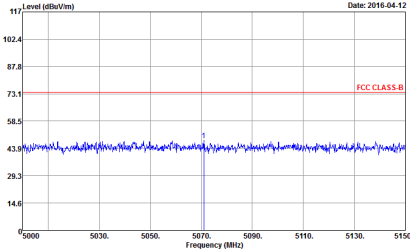
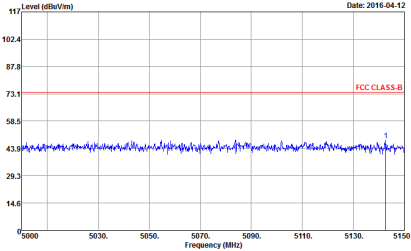
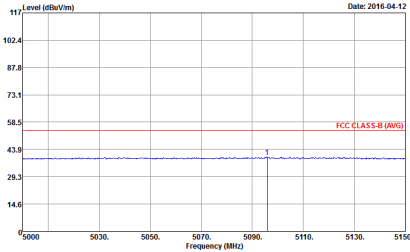
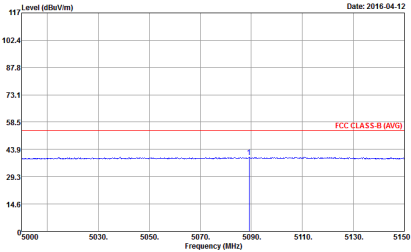

WIFI	Band 1 5150~5250MHz Band Edge @ 3m	
ANT	802.11ac VHT20 CH44 5220MHz - L	
1+2	Horizontal	Vertical
Peak	 <p>Date: 2016-04-12</p> <p>Site : 03CH11-HY Condition : FCC CLASS-B 3m HORN 9120D-HF HORIZONTAL RBW:1000.000KHz VBW:3000.000KHz SWT:Auto Detector : Peak Project : 631828 Mode : 27</p>	 <p>Date: 2016-04-12</p> <p>Site : 03CH11-HY Condition : FCC CLASS-B 3m HORN 9120D-HF VERTICAL RBW:1000.000KHz VBW:3000.000KHz SWT:Auto Detector : Peak Project : 631828 Mode : 27</p>
Avg.	 <p>Date: 2016-04-12</p> <p>Site : 03CH11-HY Condition : FCC CLASS-B (AVG) 3m HORN 9120D-HF HORIZONTAL RBW:1000.000KHz VBW:1000KHz SWT:Auto Detector : Peak Project : 631828 Mode : 27</p>	 <p>Date: 2016-04-12</p> <p>Site : 03CH11-HY Condition : FCC CLASS-B (AVG) 3m HORN 9120D-HF VERTICAL RBW:1000.000KHz VBW:1000KHz SWT:Auto Detector : Peak Project : 631828 Mode : 27</p>

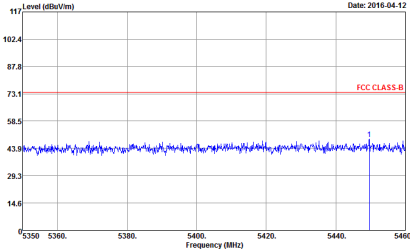
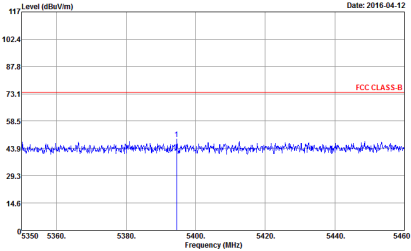
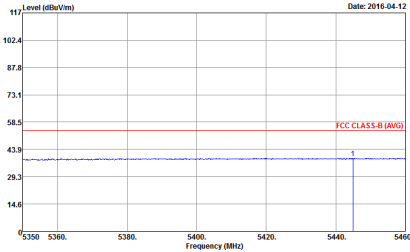
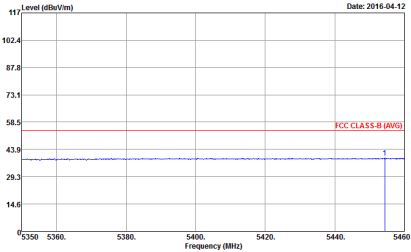

WIFI	Band 1 5150~5250MHz Band Edge @ 3m	
ANT	802.11ac VHT20 CH44 5220MHz - R	
1+2	Horizontal	Vertical
Peak	 <p>Date: 2016-04-12</p> <p>Site : 03CH11-HY Condition : FCC CLASS-B 3m HORN 9120D-HF HORIZONTAL RBW:1000.000KHz VBW:3000.000KHz SWT:Auto Detector : Peak Project : 631828 Mode : 27</p>	 <p>Date: 2016-04-12</p> <p>Site : 03CH11-HY Condition : FCC CLASS-B 3m HORN 9120D-HF VERTICAL RBW:1000.000KHz VBW:3000.000KHz SWT:Auto Detector : Peak Project : 631828 Mode : 27</p>
Avg.	 <p>Date: 2016-04-12</p> <p>Site : 03CH11-HY Condition : FCC CLASS-B (AVG) 3m HORN 9120D-HF HORIZONTAL RBW:1000.000KHz VBW:1000KHz SWT:Auto Detector : Peak Project : 631828 Mode : 27</p>	 <p>Date: 2016-04-12</p> <p>Site : 03CH11-HY Condition : FCC CLASS-B (AVG) 3m HORN 9120D-HF VERTICAL RBW:1000.000KHz VBW:1000KHz SWT:Auto Detector : Peak Project : 631828 Mode : 27</p>

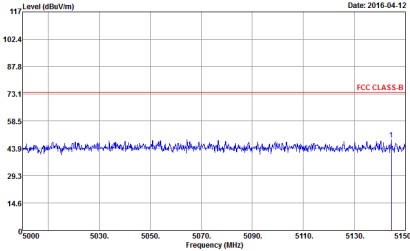
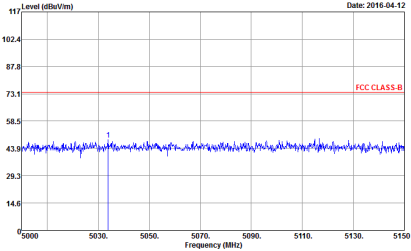
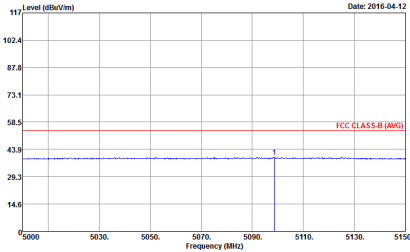
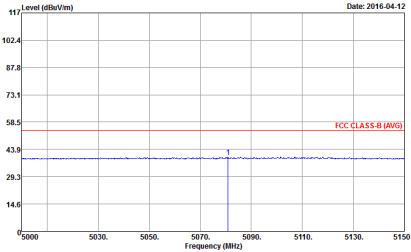

WIFI	Band 1 5150~5250MHz Band Edge @ 3m	
ANT	802.11ac VHT20 CH48 5240MHz - L	
1+2	Horizontal	Vertical
Peak	 <p>Date: 2016-04-12</p> <p>Level (dBuV/m)</p> <p>Frequency (MHz)</p> <p>Site : 03CH11-HY Condition : FCC CLASS-B 3m HORN 9120D-HF HORIZONTAL RBW:1000.000KHz VBW:3000.000KHz SWT:Auto Detector : Peak Project : 631828 Mode : ZB</p>	 <p>Date: 2016-04-12</p> <p>Level (dBuV/m)</p> <p>Frequency (MHz)</p> <p>Site : 03CH11-HY Condition : FCC CLASS-B 3m HORN 9120D-HF VERTICAL RBW:1000.000KHz VBW:3000.000KHz SWT:Auto Detector : Peak Project : 631828 Mode : ZB</p>
Avg.	 <p>Date: 2016-04-12</p> <p>Level (dBuV/m)</p> <p>Frequency (MHz)</p> <p>Site : 03CH11-HY Condition : FCC CLASS-B (AVG) 3m HORN 9120D-HF HORIZONTAL RBW:1000.000KHz VBW:1000KHz SWT:Auto Detector : Peak Project : 631828 Mode : ZB</p>	 <p>Date: 2016-04-12</p> <p>Level (dBuV/m)</p> <p>Frequency (MHz)</p> <p>Site : 03CH11-HY Condition : FCC CLASS-B (AVG) 3m HORN 9120D-HF VERTICAL RBW:1000.000KHz VBW:1000KHz SWT:Auto Detector : Peak Project : 631828 Mode : ZB</p>

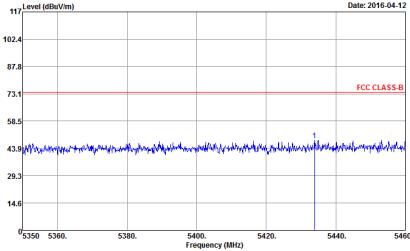
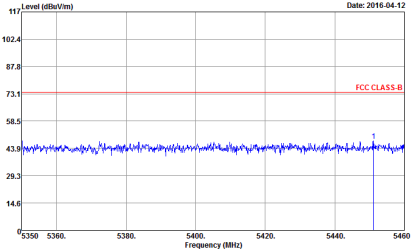
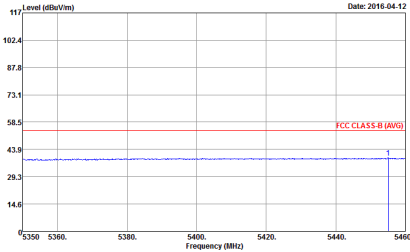
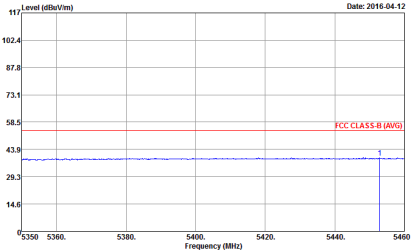

WIFI	Band 1 5150~5250MHz Band Edge @ 3m	
ANT	802.11ac VHT20 CH48 5240MHz - R	
1+2	Horizontal	Vertical
Peak	 <p>Date: 2016-04-12</p> <p>Site : 03CH11-HY Condition : FCC CLASS-B 3m HORN 9120D-HF HORIZONTAL RBW:1000.000KHz VBW:3000.000KHz SWT:Auto Detector : Peak Project : 631828 Mode : ZB</p>	 <p>Date: 2016-04-12</p> <p>Site : 03CH11-HY Condition : FCC CLASS-B 3m HORN 9120D-HF VERTICAL RBW:1000.000KHz VBW:3000.000KHz SWT:Auto Detector : Peak Project : 631828 Mode : ZB</p>
Avg.	 <p>Date: 2016-04-12</p> <p>Site : 03CH11-HY Condition : FCC CLASS-B (AVG) 3m HORN 9120D-HF HORIZONTAL RBW:1000.000KHz VBW:1000KHz SWT:Auto Detector : Peak Project : 631828 Mode : ZB</p>	 <p>Date: 2016-04-12</p> <p>Site : 03CH11-HY Condition : FCC CLASS-B (AVG) 3m HORN 9120D-HF VERTICAL RBW:1000.000KHz VBW:1000KHz SWT:Auto Detector : Peak Project : 631828 Mode : ZB</p>

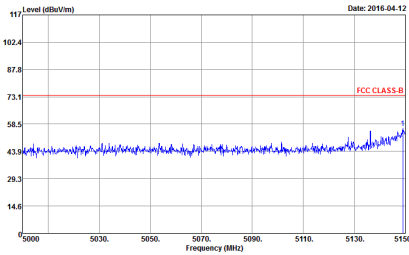
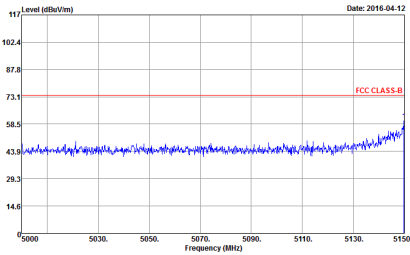
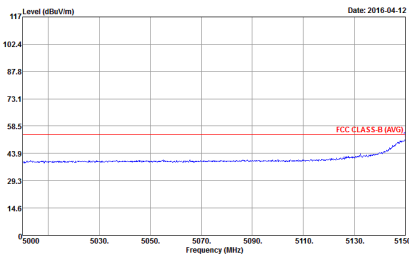
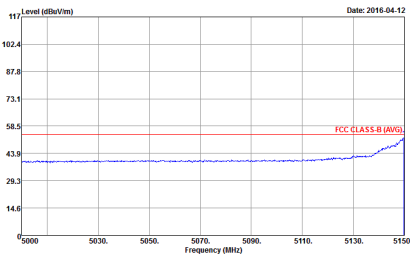

Band 1 5150~5250MHz
WIFI 802.11ac VHT40 (Band Edge @ 3m)

WIFI	Band 1 5150~5250MHz Band Edge @ 3m	
ANT	802.11ac VHT40 CH38 5190MHz - L	
1+2	Horizontal	Vertical
Peak	 <p>Site : 03CH11-HY Condition : FCC CLASS-B 3m HORN 9120D-HF HORIZONTAL Detector : Peak Project : 631828 Mode : 35 Setting : 14</p>	 <p>Site : 03CH11-HY Condition : FCC CLASS-B 3m HORN 9120D-HF VERTICAL Detector : Peak Project : 631828 Mode : 35 Setting : 14</p>
Avg.	 <p>Site : 03CH11-HY Condition : FCC CLASS-B (AVG) 3m HORN 9120D-HF HORIZONTAL Detector : Peak Project : 631828 Mode : 35 Setting : 14</p>	 <p>Site : 03CH11-HY Condition : FCC CLASS-B (AVG) 3m HORN 9120D-HF VERTICAL Detector : Peak Project : 631828 Mode : 35 Setting : 14</p>

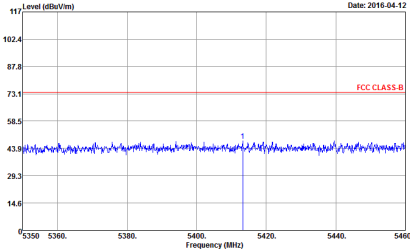
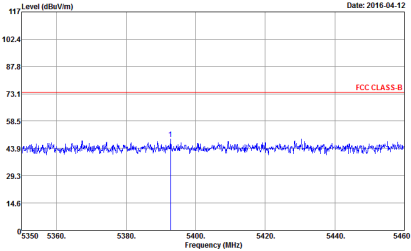
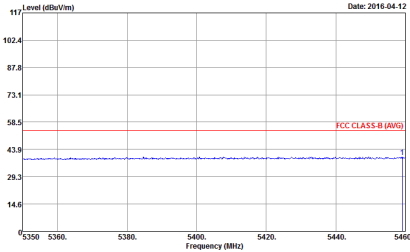
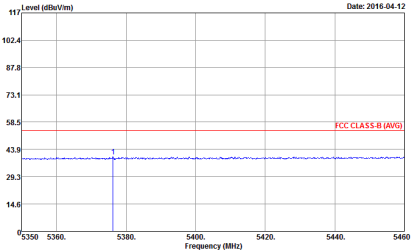

WIFI	Band 1 5150~5250MHz Band Edge @ 3m	
ANT	802.11ac VHT40 CH38 5190MHz - R	
1+2	Horizontal	Vertical
Peak	 <p>Date: 2016-04-12</p> <p>Site : 03CH11-HY Condition : FCC CLASS-B 3m HORN 9120D-HF HORIZONTAL RBW:1000.000KHz VBW:3000.000KHz SWT:Auto Detector : Peak Project : 631828 Mode : 35 Setting : 14</p>	 <p>Date: 2016-04-12</p> <p>Site : 03CH11-HY Condition : FCC CLASS-B 3m HORN 9120D-HF VERTICAL RBW:1000.000KHz VBW:3000.000KHz SWT:Auto Detector : Peak Project : 631828 Mode : 35 Setting : 14</p>
Avg.	 <p>Date: 2016-04-12</p> <p>Site : 03CH11-HY Condition : FCC CLASS-B (AVG) 3m HORN 9120D-HF HORIZONTAL RBW:1000.000KHz VBW:3.000KHz SWT:Auto Detector : Peak Project : 631828 Mode : 35 Setting : 14</p>	 <p>Date: 2016-04-12</p> <p>Site : 03CH11-HY Condition : FCC CLASS-B (AVG) 3m HORN 9120D-HF VERTICAL RBW:1000.000KHz VBW:3.000KHz SWT:Auto Detector : Peak Project : 631828 Mode : 35 Setting : 14</p>

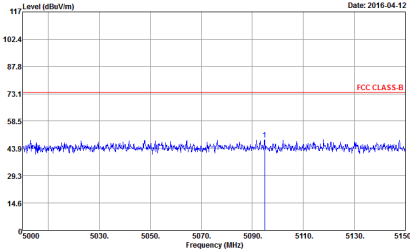
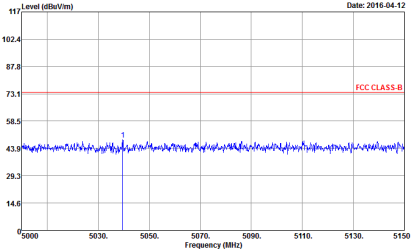
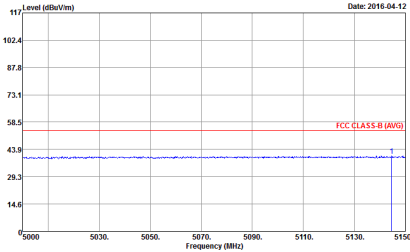
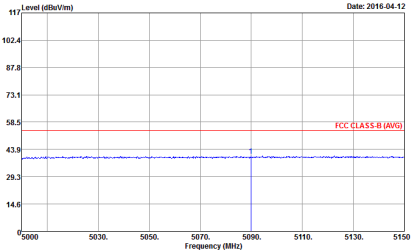

WIFI	Band 1 5150~5250MHz Band Edge @ 3m	
ANT	802.11ac VHT40 CH46 5230MHz - L	
1+2	Horizontal	Vertical
Peak	 <p>Date: 2016-04-12</p> <p>Site : 03CH11-HY Condition : FCC CLASS-B 3m HORN 9120D-HF HORIZONTAL RBW:1000.000KHz VBW:3000.000KHz SWT:Auto Detector : Peak Project : 631828 Mode : 36</p>	 <p>Date: 2016-04-12</p> <p>Site : 03CH11-HY Condition : FCC CLASS-B 3m HORN 9120D-HF VERTICAL RBW:1000.000KHz VBW:3000.000KHz SWT:Auto Detector : Peak Project : 631828 Mode : 36</p>
Avg.	 <p>Date: 2016-04-12</p> <p>Site : 03CH11-HY Condition : FCC CLASS-B (AVG) 3m HORN 9120D-HF HORIZONTAL RBW:1000.000KHz VBW:3.000KHz SWT:Auto Detector : Peak Project : 631828 Mode : 36</p>	 <p>Date: 2016-04-12</p> <p>Site : 03CH11-HY Condition : FCC CLASS-B (AVG) 3m HORN 9120D-HF VERTICAL RBW:1000.000KHz VBW:3.000KHz SWT:Auto Detector : Peak Project : 631828 Mode : 36</p>

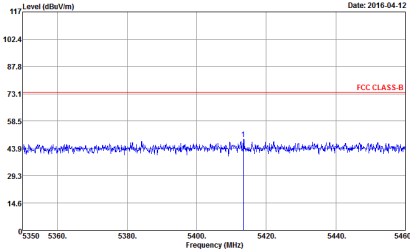
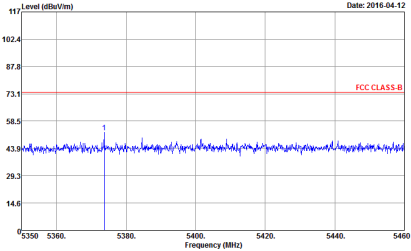
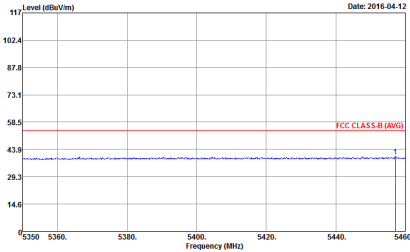
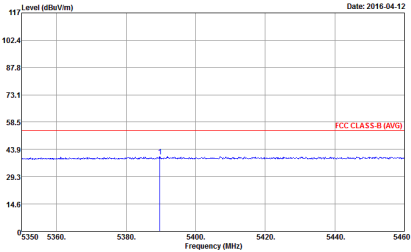

WIFI	Band 1 5150~5250MHz Band Edge @ 3m	
ANT	802.11ac VHT40 CH46 5230MHz - R	
1+2	Horizontal	Vertical
Peak	 <p>Date: 2016-04-12</p> <p>Site : 03CH11-HY Condition : FCC CLASS-B 3m HORN 9120D-HF HORIZONTAL RBW:1000.000KHz VBW:3000.000KHz SWT:Auto Detector : Peak Project : 631828 Mode : 36</p>	 <p>Date: 2016-04-12</p> <p>Site : 03CH11-HY Condition : FCC CLASS-B 3m HORN 9120D-HF VERTICAL RBW:1000.000KHz VBW:3000.000KHz SWT:Auto Detector : Peak Project : 631828 Mode : 36</p>
Avg.	 <p>Date: 2016-04-12</p> <p>Site : 03CH11-HY Condition : FCC CLASS-B (AVG) 3m HORN 9120D-HF HORIZONTAL RBW:1000.000KHz VBW:3.000KHz SWT:Auto Detector : Peak Project : 631828 Mode : 36</p>	 <p>Date: 2016-04-12</p> <p>Site : 03CH11-HY Condition : FCC CLASS-B (AVG) 3m HORN 9120D-HF VERTICAL RBW:1000.000KHz VBW:3.000KHz SWT:Auto Detector : Peak Project : 631828 Mode : 36</p>

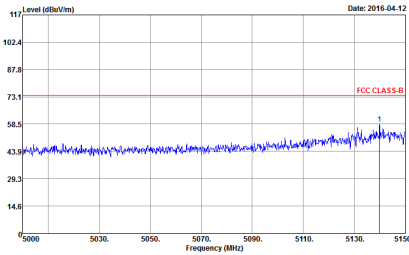
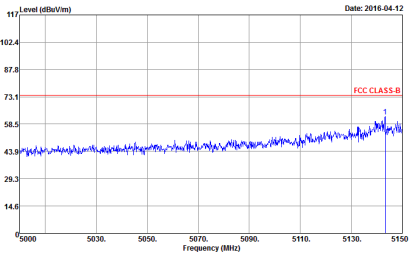
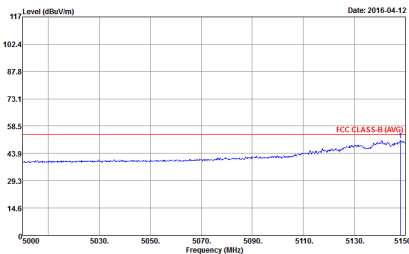
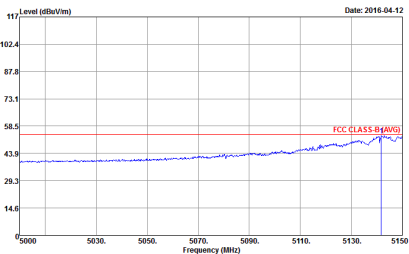

Band 1 5150~5250MHz
WIFI 802.11ac VHT80 (Band Edge @ 3m)

WIFI	Band 1 5150~5250MHz Band Edge @ 3m	
ANT	802.11ac VHT80 CH42 5210MHz - L	
1+2	Horizontal	Vertical
Peak	 <p>Site : 03CH11-HY Condition : FCC CLASS-B 3m HORN 9120D-HF HORIZONTAL Detector : Peak Project : 631828 Mode : 42 Power : 13.5</p>	 <p>Site : 03CH11-HY Condition : FCC CLASS-B 3m HORN 9120D-HF VERTICAL Detector : Peak Project : 631828 Mode : 42 Power : 13.5</p>
Avg.	 <p>Site : 03CH11-HY Condition : FCC CLASS-B (AVG) 3m HORN 9120D-HF HORIZONTAL Detector : Peak Project : 631828 Mode : 42 Power : 13.5</p>	 <p>Site : 03CH11-HY Condition : FCC CLASS-B (AVG) 3m HORN 9120D-HF VERTICAL Detector : Peak Project : 631828 Mode : 42 Power : 13.5</p>