



FCC RF Test Report

APPLICANT : Motorola Mobility, LLC
EQUIPMENT : Mobile Cellular Phone
BRAND NAME : Motorola
MODEL NAME : 5137
FCC ID : IHDT56UC2
STANDARD : FCC 47 CFR Part 2, 22(H), 24(E), 27(L)
CLASSIFICATION : PCS Licensed Transmitter Held to Ear (PCE)

The product was received on Apr. 15, 2015 and testing was completed on May 20, 2015. We, SPORTON INTERNATIONAL INC., would like to declare that the tested sample has been evaluated in accordance with the test procedures given in ANSI / TIA / EIA-603-C-2004 and has been in compliance with the applicable technical standards.

The test results in this report apply exclusively to the tested model / sample. Without written approval of SPORTON INTERNATIONAL INC., the test report shall not be reproduced except in full.

Reviewed by: Joseph Lin / Supervisor

Approved by: Jones Tsai / Manager



SPORTON INTERNATIONAL INC.

No. 52, Hwa Ya 1st Rd., Hwa Ya Technology Park, Kwei-Shan District, Tao Yuan City, Taiwan, R.O.C.



TABLE OF CONTENTS

REVISION HISTORY.....3

SUMMARY OF TEST RESULT4

1 GENERAL DESCRIPTION.....5

1.1 Applicant.....5

1.2 Manufacturer5

1.3 Product Feature of Equipment Under Test5

1.4 Product Specification subjective to this standard.....6

1.5 Modification of EUT6

1.6 Maximum ERP/EIRP Power, Frequency Tolerance, and Emission Designator7

1.7 Testing Location7

1.8 Applicable Standards7

2 TEST CONFIGURATION OF EQUIPMENT UNDER TEST.....8

2.1 Test Mode.....8

2.2 Connection Diagram of Test System 10

2.3 Support Unit used in test configuration 11

2.4 Measurement Results Explanation Example 11

3 TEST RESULT..... 12

3.1 Conducted Output Power Measurement..... 12

3.2 Peak-to-Average Ratio 14

3.3 Effective Radiated Power and Effective Isotropic Radiated Power Measurement 30

3.4 99% Occupied Bandwidth and 26dB Bandwidth Measurement..... 34

3.5 Band Edge Measurement..... 57

3.6 Conducted Spurious Emission Measurement..... 65

3.7 Field Strength of Spurious Radiation Measurement 87

3.8 Frequency Stability Measurement..... 116

4 LIST OF MEASURING EQUIPMENT 121

5 UNCERTAINTY OF EVALUATION..... 122



SUMMARY OF TEST RESULT

Report Section	FCC Rule	Description	Limit	Result	Remark
3.1	§2.1046	Conducted Output Power	Reporting Only	PASS	-
3.2	§24.232(d)	Peak-to-Average Ratio	< 13 dB	PASS	-
3.3	§22.913(a)(2)	Effective Radiated Power	< 7 Watts	PASS	-
	§24.232(c)	Equivalent Isotropic Radiated Power	< 2 Watts	PASS	-
	§27.50(d)(4)	Equivalent Isotropic Radiated Power	< 1 Watts	PASS	-
3.4	§2.1049	Occupied Bandwidth	Reporting Only	PASS	-
3.5	§2.1051 §22.917(a) §24.238(a) §27.53(h)	Band Edge Measurement	< 43+10log10(P[Watts])	PASS	-
3.6	§2.1051 §22.917(a) §24.238(a) §27.53(h)	Conducted Emission	< 43+10log10(P[Watts])	PASS	-
3.7	§2.1053 §22.917(a) §24.238(a) §27.53(h)	Field Strength of Spurious Radiation	< 43+10log10(P[Watts])	PASS	Under limit 25.39 dB at 1696.000 MHz
3.8	§2.1055 §22.355	Frequency Stability for Temperature & Voltage	< 2.5 ppm for Part 22 Within Authorized Band	PASS	-
	§2.1055 §24.235 §27.54				



1 General Description

1.1 Applicant

Motorola Mobility, LLC

222 W Merchandise Mart Plaza, Suite 1800, Chicago, IL 60654, United States

1.2 Manufacturer

Motorola Mobility, LLC

222 W Merchandise Mart Plaza, Suite 1800, Chicago, IL 60654, United States

1.3 Product Feature of Equipment Under Test

Product Feature	
Equipment	Mobile Cellular Phone
Brand Name	Motorola
Model Name	5137
FCC ID	IHDT56UC2
IMEI Code	IMEI 1:355486060017458 IMEI 2:355486060017870
EUT supports Radios application	GSM/EGPRS/WCDMA/HSPA/LTE/NFC 2.4GHz WLAN 11b/g/n HT20 WLAN 11ac VHT20 5GHz WLAN 11a/n HT20/HT40 WLAN 11ac VHT20/VHT40/VHT80 Bluetooth v3.0 EDR Bluetooth v4.1 - LE
HW Version	P2
EUT Stage	Identical Prototype

Remark: The above EUT's information was declared by manufacturer. Please refer to the specifications or user's manual for more detailed description.

Accessory List	
AC Adapter 1	Brand Name : Motorola
	Model Name : SPN5791A
AC Adapter 2	Brand Name : Motorola
	Model Name : SPN5864A
AC Adapter 3	Brand Name : Motorola
	Model Name : SPN5886A
USB Cable	Brand Name : Motorola
	Model Name : SKN6461A
Battery	Brand Name : Motorola
	Model Name : FX30
Earphone	Brand Name : Motorola
	Model Name : SJYN1305A

1.4 Product Specification subjective to this standard

Product Specification subjective to this standard	
Tx Frequency	GSM850: 824.2 MHz ~ 848.8 MHz GSM1900: 1850.2 MHz ~ 1909.8MHz WCDMA Band V: 826.4 MHz ~ 846.6 MHz WCDMA Band IV : 1712.4 MHz ~ 1752.6 MHz WCDMA Band II: 1852.4 MHz ~ 1907.6 MHz
Rx Frequency	GSM850: 869.2 MHz ~ 893.8 MHz GSM1900: 1930.2 MHz ~ 1989.8 MHz WCDMA Band V: 871.4 MHz ~ 891.6 MHz WCDMA Band IV : 2112.4 MHz ~ 2152.6 MHz WCDMA Band II: 1932.4 MHz ~ 1987.6 MHz
Maximum Output Power to Antenna	GSM850 : 32.30 dBm GSM1900 : 29.05 dBm WCDMA Band V : 23.74 dBm WCDMA Band IV : 23.55dBm WCDMA Band II : 23.11 dBm
Antenna Type	Fixed Internal Antenna
Type of Modulation	GSM: GMSK GPRS: GMSK EDGE: GMSK / 8PSK WCDMA: QPSK (Uplink) HSDPA: 64QAM (Downlink) HSUPA: QPSK (Uplink)

1.5 Modification of EUT

No modifications are made to the EUT during all test items.



1.6 Maximum ERP/EIRP Power, Frequency Tolerance, and Emission Designator

FCC Rule	System	Type of Modulation	Maximum ERP/EIRP (W)	Frequency Tolerance (ppm)	Emission Designator
Part 22	GSM850 GPRS class 8	GMSK	0.8433	0.0143 ppm	247KGXW
Part 22	GSM850 EDGE class 8	8PSK	0.1629	0.0132 ppm	245KG7W
Part 22	WCDMA Band V RMC 12.2Kbps	QPSK	0.1096	0.0167 ppm	4M15F9W
Part 24	GSM1900 GPRS class 8	GMSK	1.2735	0.0059 ppm	249KGXW
Part 24	GSM1900 EDGE class 8	8PSK	0.3524	0.0059 ppm	249KG7W
Part 24	WCDMA Band II RMC 12.2Kbps	QPSK	0.1977	0.0074 ppm	4M16F9W
Part 27	WCDMA Band IV RMC 12.2Kbps	QPSK	0.1507	0.0029 ppm	4M14F9W

1.7 Testing Location

Sporton Lab is accredited to ISO 17025 by Taiwan Accreditation Foundation (TAF code : 1190) and the FCC designation No. TW1022 under the FCC 2.948(e) by Mutual Recognition Agreement (MRA) in FCC Test.

Test Site	SPORTON INTERNATIONAL INC.	
Test Site Location	No. 52, Hwa Ya 1 st Rd., Hwa Ya Technology Park, Kwei-Shan District, Tao Yuan City, Taiwan, R.O.C. TEL: +886-3-327-3456 FAX: +886-3-328-4978	
Test Site No.	Sporton Site No.	
	TH02-HY	03CH07-HY

1.8 Applicable Standards

According to the specifications of the manufacturer, the EUT must comply with the requirements of the following standards:

- FCC 47 CFR Part 2, 22(H), 24(E), 27(L)
- ANSI / TIA / EIA-603-C-2004
- FCC KDB 971168 D01 Power Meas. License Digital Systems v02r02

Remark:

1. All test items were verified and recorded according to the standards and without any deviation during the test.
2. This EUT has also been tested and complied with the requirements of FCC Part 15, Subpart B, recorded in a separate test report.



2 Test Configuration of Equipment Under Test

2.1 Test Mode

Antenna port conducted and radiated test items were performed according to KDB 971168 D01 Power Meas. License Digital Systems v02r02 with maximum output power.

Radiated measurements were performed with rotating EUT in different three orthogonal test planes to find the maximum emission.

Radiated emissions were investigated as following frequency range:

1. 30 MHz to 9000 MHz for GSM850 and WCDMA Band V.
2. 30 MHz to 19000 MHz for GSM1900 and WCDMA Band II.
3. 30 MHz to 18000 MHz for WCDMA Band IV.

All modes and data rates and positions were investigated.

Test modes are chosen to be reported as the worst case configuration below:

Test Modes		
Band	Radiated TCs	Conducted TCs
GSM 850	<ul style="list-style-type: none"> ■ GPRS class 8 Link for Adapter 1 ■ GPRS class 8 Link for Adapter 2 ■ GPRS class 8 Link for Adapter 3 ■ EDGE class 8 Link for Adapter 1 	<ul style="list-style-type: none"> ■ GPRS class 8 Link ■ EDGE class 8 Link
GSM 1900	<ul style="list-style-type: none"> ■ GPRS class 8 Link for Adapter 1 ■ EDGE class 8 Link for Adapter 1 	<ul style="list-style-type: none"> ■ GPRS class 8 Link ■ EDGE class 8 Link
WCDMA Band V	<ul style="list-style-type: none"> ■ RMC 12.2Kbps Link for Adapter 1 	<ul style="list-style-type: none"> ■ RMC 12.2Kbps Link
WCDMA Band IV	<ul style="list-style-type: none"> ■ RMC 12.2Kbps Link for Adapter 1 	<ul style="list-style-type: none"> ■ RMC 12.2Kbps Link
WCDMA Band II	<ul style="list-style-type: none"> ■ RMC 12.2Kbps Link for Adapter 1 	<ul style="list-style-type: none"> ■ RMC 12.2Kbps Link

Note: The maximum power levels are chosen to test as the worst case configuration as follows:

- GPRS multi-slot class 8 mode for GMSK modulation,
- EDGE multi-slot class 8 mode for 8PSK modulation,
- RMC 12.2Kbps mode for WCDMA band V, WCDMA band IV, and WCDMA band II,
- only these modes were used for all tests.



Conducted Power Measurement Results:

Conducted Power (*Unit: dBm)						
Band	GSM850			GSM1900		
Channel	128	189	251	512	661	810
Frequency	824.2	836.4	848.8	1850.2	1880.0	1909.8
GSM	32.27	31.95	32.11	28.94	28.98	29.05
GPRS class 8	32.30	31.94	32.13	28.95	29.03	29.05
GPRS class 10	28.50	28.55	28.73	25.75	25.82	25.93
GPRS class 11	26.83	26.98	27.10	23.75	23.79	23.80
GPRS class 12	25.50	24.92	25.13	22.50	22.60	22.70
EGPRS class 8	26.01	26.11	26.18	25.00	25.04	25.08
EGPRS class 10	23.41	23.51	23.55	22.41	22.47	22.55
EGPRS class 11	22.92	23.13	23.24	20.98	21.04	21.15
EGPRS class 12	21.33	21.41	21.43	19.66	19.71	19.81

Conducted Power (*Unit: dBm)									
Band	WCDMA Band V			WCDMA Band II			WCDMA Band IV		
Channel	4132	4182	4233	9262	9400	9538	1312	1413	1513
Frequency	826.4	836.4	846.6	1852.4	1880.0	1907.6	1712.4	1732.6	1752.6
RMC 12.2K	23.74	23.72	23.69	22.87	23.00	23.11	23.55	23.30	22.93
HSDPA Subtest-1	22.50	22.56	22.68	21.88	22.06	21.88	22.38	22.22	21.95
HSDPA Subtest-2	22.45	22.49	22.60	21.73	21.93	21.96	22.25	22.30	21.90
HSDPA Subtest-3	22.01	21.96	22.09	21.21	21.43	21.64	21.75	21.38	21.40
HSDPA Subtest-4	22.00	21.91	22.03	21.19	21.40	21.42	21.64	21.28	21.30
HSUPA Subtest-1	21.69	21.55	21.89	21.33	21.39	21.46	21.83	21.69	21.44
HSUPA Subtest-2	20.74	20.79	20.93	20.59	20.66	20.77	20.76	20.72	20.61
HSUPA Subtest-3	20.66	20.69	20.72	20.61	20.54	20.81	20.99	20.87	20.71
HSUPA Subtest-4	21.10	21.12	21.18	20.82	21.19	21.22	21.02	20.88	20.81
HSUPA Subtest-5	22.19	22.09	22.24	21.69	21.72	21.93	22.11	22.06	22.09

2.2 Connection Diagram of Test System

<For AC Adapter 1>

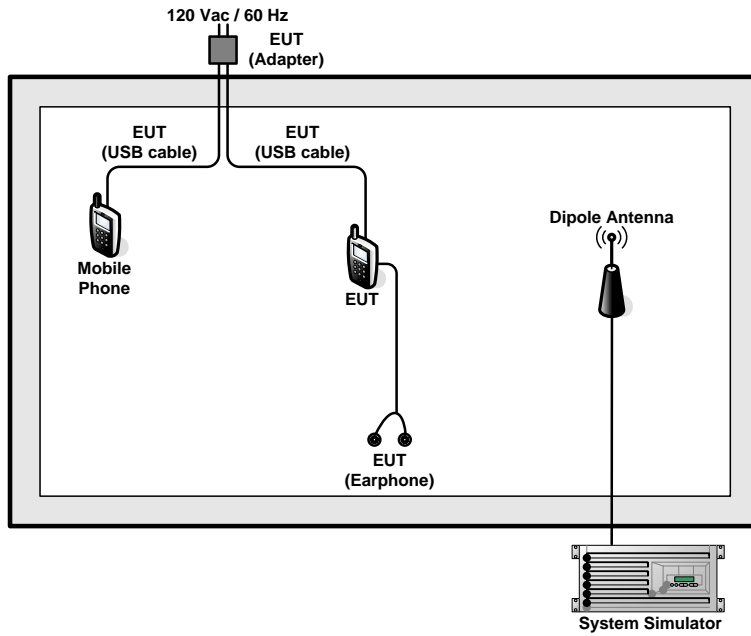

<For AC Adapter 2>

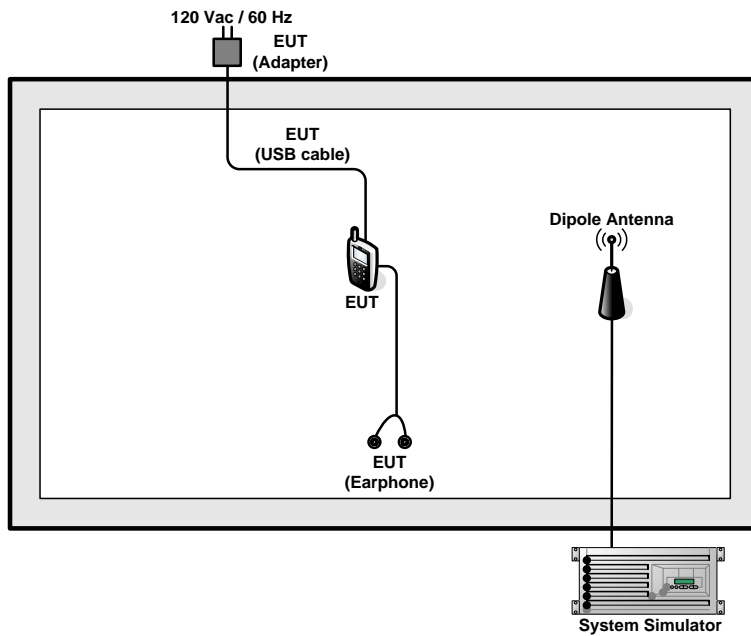

<For AC Adapter 3>

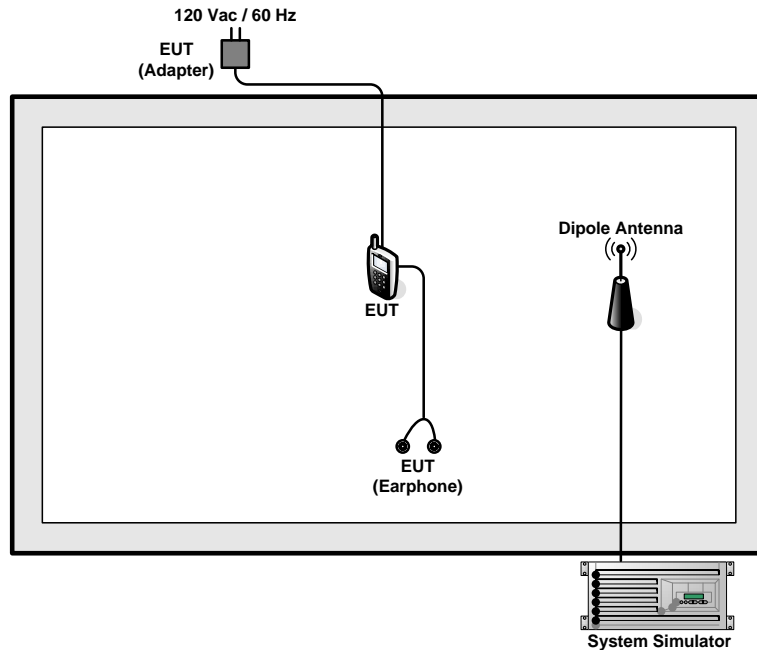

2.3 Support Unit used in test configuration

Item	Equipment	Trade Name	Model No.	FCC ID	Data Cable	Power Cord
1.	System Simulator	R&S	CMU 200	N/A	N/A	Unshielded, 1.8 m
2.	System Simulator	Anritsu	MT8820C	N/A	N/A	Unshielded, 1.8 m
3.	Mobile Phone	Motorola	5137	IHDT56UC2	N/A	Unshielded, 1.0 m

2.4 Measurement Results Explanation Example

For all conducted test items:

The offset level is set in the spectrum analyzer to compensate the RF cable loss and attenuator factor between RF conducted output port and spectrum analyzer. With the offset compensation, the spectrum analyzer reading level will be exactly the RF output level.

The spectrum analyzer offset is derived from RF cable loss and attenuator factor.

$$\text{Offset} = \text{RF cable loss} + \text{attenuator factor}.$$

The following shows an offset computation example with RF cable loss 4.2 dB and a 10dB attenuator.

Example :

$$\begin{aligned} \text{Offset(dB)} &= \text{RF cable loss(dB)} + \text{attenuator factor(dB)}. \\ &= 4.2 + 10 = 14.2 \text{ (dB)} \end{aligned}$$

3 Test Result

3.1 Conducted Output Power Measurement

3.1.1 Description of the Conducted Output Power Measurement

A system simulator was used to establish communication with the EUT. Its parameters were set to enforce EUT transmitting at the maximum power. The measured power in the radio frequency on the transmitter output terminals shall be reported.

3.1.2 Measuring Instruments

The measuring equipment is listed in the section 4 of this test report.

3.1.3 Test Procedures

1. The transmitter output port was connected to the system simulator.
2. Set EUT at maximum power through system simulator.
3. Select lowest, middle, and highest channels for each band and different modulation.
4. Measure the maximum burst average power for GSM and maximum average power for other modulation signal.

3.1.4 Test Setup

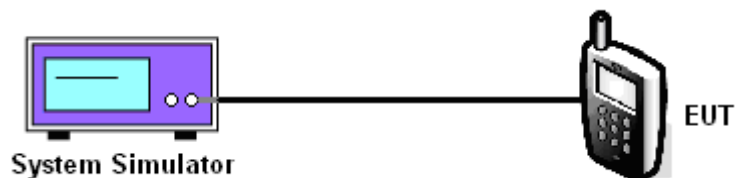



3.1.5 Test Result of Conducted Output Power

Cellular Band									
Modes	GSM850 (GPRS class 8)			GSM850 (EDGE class 8)			WCDMA Band V (RMC 12.2Kbps)		
Channel	128 (Low)	189 (Mid)	251 (High)	128 (Low)	189 (Mid)	251 (High)	4132 (Low)	4182 (Mid)	4233 (High)
Frequency (MHz)	824.2	836.4	848.8	824.2	836.4	848.8	826.4	836.4	846.6
Conducted Power (dBm)	32.30	31.94	32.13	26.01	26.11	26.18	23.74	23.72	23.69

PCS Band									
Modes	GSM1900 (GPRS class 8)			GSM1900 (EDGE class 8)			WCDMA Band II (RMC 12.2Kbps)		
Channel	512 (Low)	661 (Mid)	810 (High)	512 (Low)	661 (Mid)	810 (High)	9262 (Low)	9400 (Mid)	9538 (High)
Frequency (MHz)	1850.2	1880	1909.8	1850.2	1880	1909.8	1852.4	1880	1907.6
Conducted Power (dBm)	28.95	29.03	29.05	25.00	25.04	25.08	22.87	23.00	23.11

AWS Band			
Modes	WCDMA Band IV (RMC 12.2Kbps)		
Channel	1312(Low)	1413 (Mid)	1513 (High)
Frequency (MHz)	1712.4	1732.6	1752.6
Conducted Power (dBm)	23.55	23.30	22.93

Note: maximum burst average power for GPRS, and maximum average power for WCDMA.

3.2 Peak-to-Average Ratio

3.2.1 Description of the PAR Measurement

The peak-to-average ratio (PAR) of the transmission may not exceed 13 dB.

3.2.2 Measuring Instruments

The measuring equipment is listed in the section 4 of this test report.

3.2.3 Test Procedures

1. The EUT was connected to spectrum analyzer and system simulator via a power divider.
2. Set EUT to transmit at maximum output power.
3. When the duty cycle is less than 98%, then signal gating will be implemented on the spectrum analyzer by triggering from the system simulator.
4. Set the CCDF (Complementary Cumulative Distribution Function) option of the spectrum analyzer.
5. Record the maximum PAPR level associated with a probability of 0.1%.

3.2.4 Test Setup

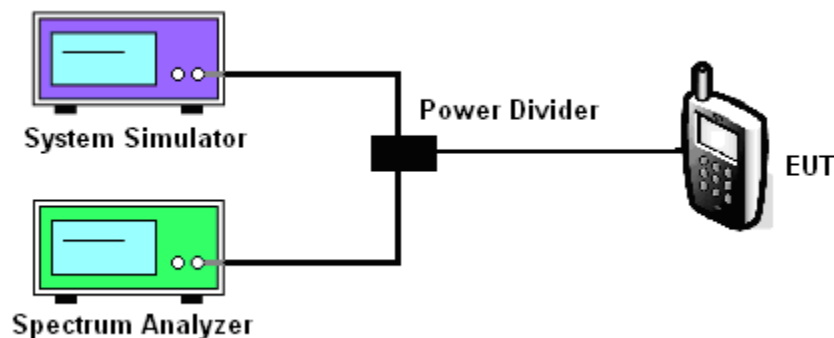



3.2.5 Test Result of Peak-to-Average Ratio

Cellular Band									
Modes	GSM850 (GPRS class 8)			GSM850 (EDGE class 8)			WCDMA Band V (RMC 12.2Kbps)		
Channel	128 (Low)	189 (Mid)	251 (High)	128 (Low)	189 (Mid)	251 (High)	4132 (Low)	4182 (Mid)	4233 (High)
Frequency (MHz)	824.2	836.4	848.8	824.2	836.4	848.8	826.4	836.4	846.6
Peak-to-Average Ratio (dB)	0.36	0.32	0.32	3.28	3.20	3.28	3.92	3.56	3.52

PCS Band									
Modes	GSM1900 (GPRS class 8)			GSM1900 (EDGE class 8)			WCDMA Band II (RMC 12.2Kbps)		
Channel	512 (Low)	661 (Mid)	810 (High)	512 (Low)	661 (Mid)	810 (High)	9262 (Low)	9400 (Mid)	9538 (High)
Frequency (MHz)	1850.2	1880	1909.8	1850.2	1880	1909.8	1852.4	1880	1907.6
Peak-to-Average Ratio (dB)	0.28	0.24	0.28	3.36	3.24	3.32	3.32	3.28	3.44

AWS Band			
Modes	WCDMA Band IV (RMC 12.2Kbps)		
Channel	1312(Low)	1413 (Mid)	1513 (High)
Frequency (MHz)	1712.4	1732.6	1752.6
Peak-to-Average Ratio (dB)	3.64	3.48	3.60



3.2.6 Test Result (Plots) of Peak-to-Average Ratio

Band :	GSM 850	Test Mode :	GPRS class 8 Link (GMSK)
---------------	---------	--------------------	--------------------------

Peak-to-Average Ratio on Channel 128 (824.2 MHz)

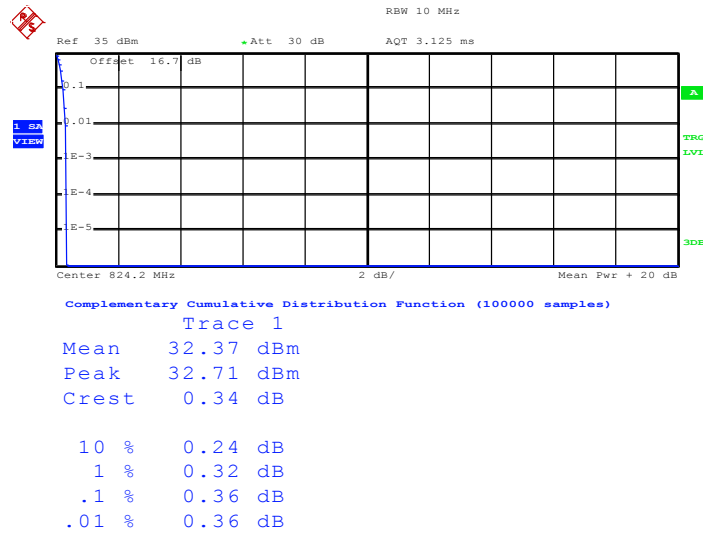

Date: 28.APR.2015 10:24:21

Peak-to-Average Ratio on Channel 189 (836.4 MHz)

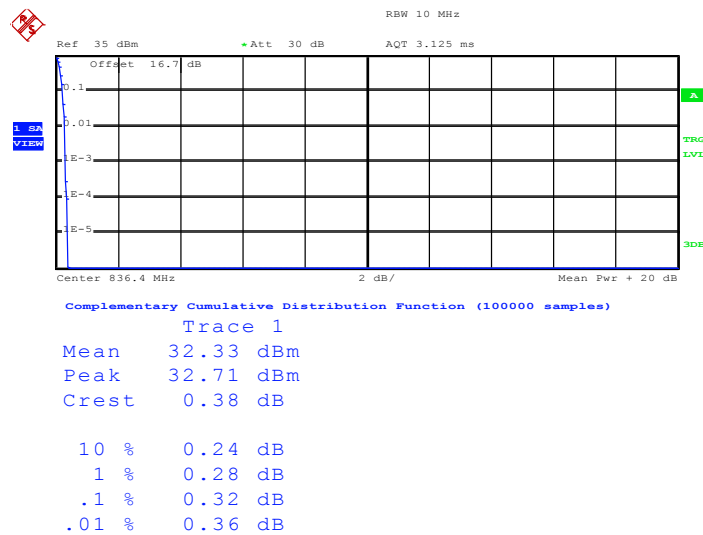

Date: 28.APR.2015 10:24:43



Peak-to-Average Ratio on Channel 251 (848.8 MHz)

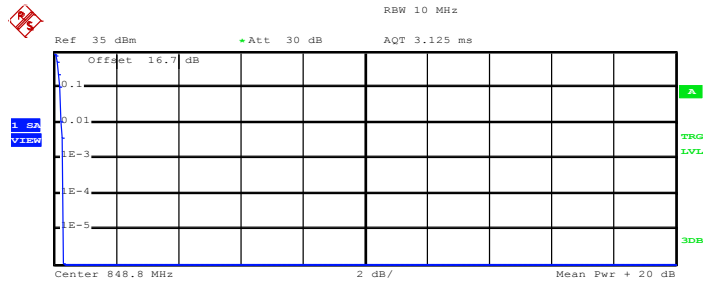

Complementary Cumulative Distribution Function (100000 samples)

Trace 1

Mean	33.19 dBm
Peak	33.49 dBm
Crest	0.30 dB
10 %	0.20 dB
1 %	0.24 dB
.1 %	0.32 dB
.01 %	0.32 dB

Date: 28.APR.2015 10:24:58



Band :	GSM 850	Test Mode :	EDGE class 8 Link (8PSK)
---------------	---------	--------------------	--------------------------

Peak-to-Average Ratio on Channel 128 (824.2 MHz)

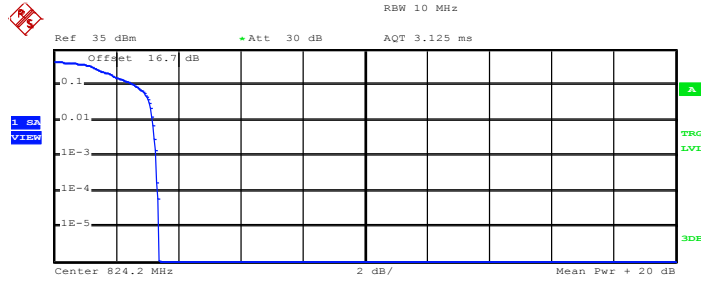

Complementary Cumulative Distribution Function (100000 samples)

Trace 1

Mean	26.16 dBm
Peak	29.54 dBm
Crest	3.37 dB
10 %	2.60 dB
1 %	3.20 dB
.1 %	3.28 dB
.01 %	3.36 dB

Date: 28.APR.2015 10:37:15

Peak-to-Average Ratio on Channel 189 (836.4 MHz)

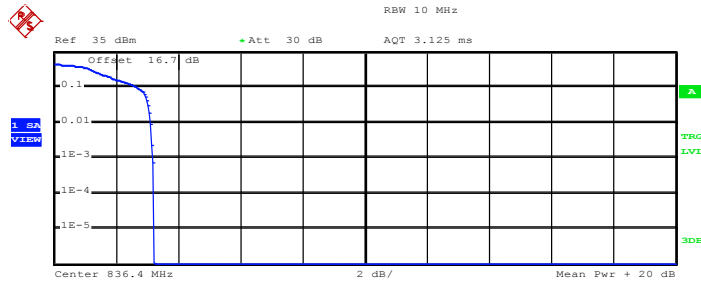

Complementary Cumulative Distribution Function (100000 samples)

Trace 1

Mean	26.68 dBm
Peak	29.89 dBm
Crest	3.21 dB
10 %	2.68 dB
1 %	3.12 dB
.1 %	3.20 dB
.01 %	3.24 dB

Date: 28.APR.2015 10:37:29



Peak-to-Average Ratio on Channel 251 (848.8 MHz)

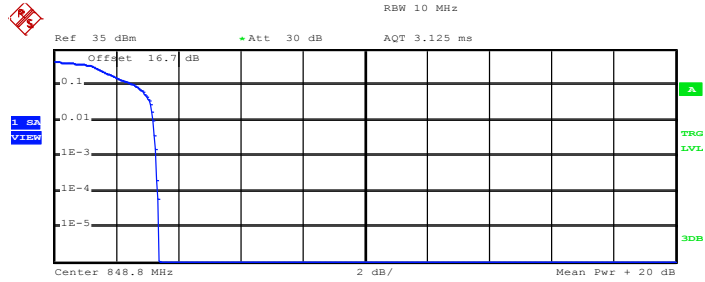

Complementary Cumulative Distribution Function (100000 samples)

Trace 1

Mean	27.44 dBm
Peak	30.81 dBm
Crest	3.37 dB
10 %	2.64 dB
1 %	3.20 dB
.1 %	3.28 dB
.01 %	3.36 dB

Date: 28.APR.2015 10:37:48



Band :	GSM 1900	Test Mode :	GPRS class 8 Link (GMSK)
---------------	----------	--------------------	--------------------------

Peak-to-Average Ratio on Channel 512 (1850.2 MHz)

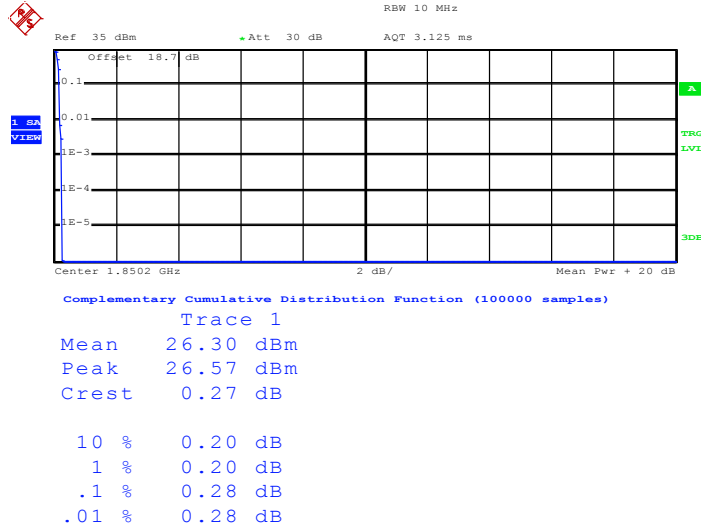

Date: 28.APR.2015 14:22:58

Peak-to-Average Ratio on Channel 661 (1880.0 MHz)

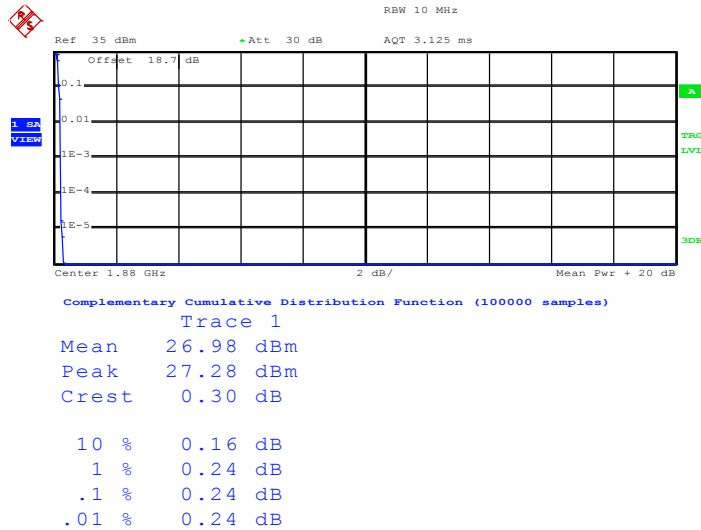

Date: 28.APR.2015 14:23:11



Peak-to-Average Ratio on Channel 810 (1909.8 MHz)

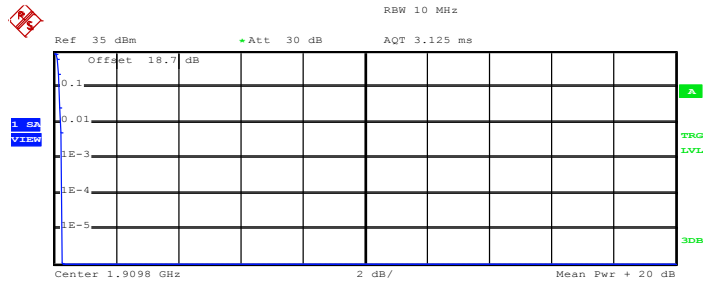

Complementary Cumulative Distribution Function (100000 samples)

Trace 1

Mean	26.75 dBm
Peak	27.00 dBm
Crest	0.25 dB
10 %	0.20 dB
1 %	0.24 dB
.1 %	0.28 dB
.01 %	0.28 dB

Date: 28.APR.2015 14:23:26



Band :	GSM 1900	Test Mode :	EDGE class 8 Link (8PSK)
---------------	----------	--------------------	--------------------------

Peak-to-Average Ratio on Channel 512 (1850.2 MHz)

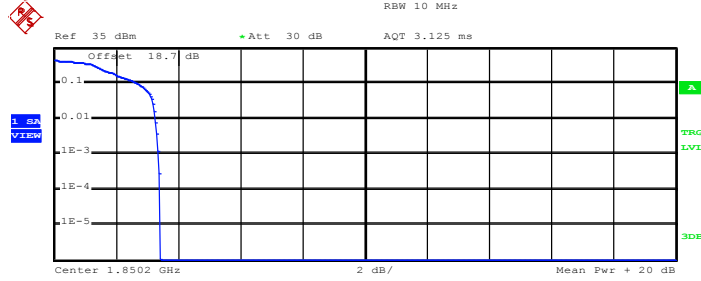

Complementary Cumulative Distribution Function (100000 samples)

Trace 1

Mean	25.71 dBm
Peak	29.11 dBm
Crest	3.41 dB
10 %	2.72 dB
1 %	3.28 dB
.1 %	3.36 dB
.01 %	3.44 dB

Date: 28.APR.2015 14:07:16

Peak-to-Average Ratio on Channel 661 (1880.0 MHz)

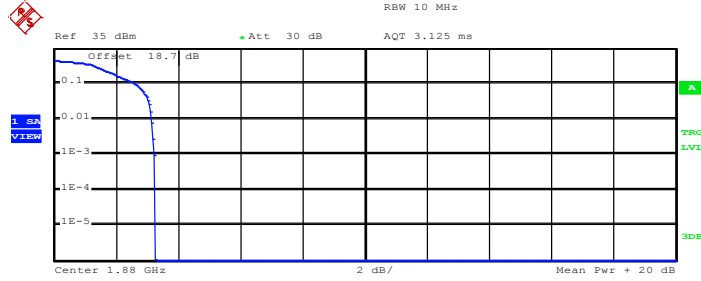

Complementary Cumulative Distribution Function (100000 samples)

Trace 1

Mean	26.27 dBm
Peak	29.54 dBm
Crest	3.27 dB
10 %	2.64 dB
1 %	3.16 dB
.1 %	3.24 dB
.01 %	3.28 dB

Date: 28.APR.2015 14:07:27



Peak-to-Average Ratio on Channel 810 (1909.8 MHz)

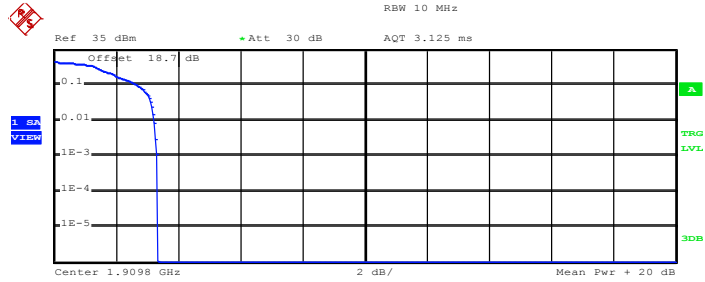

Complementary Cumulative Distribution Function (100000 samples)

Trace 1	
Mean	25.98 dBm
Peak	29.33 dBm
Crest	3.35 dB
10 %	2.72 dB
1 %	3.24 dB
.1 %	3.32 dB
.01 %	3.36 dB

Date: 28.APR.2015 14:07:40



Band :	WCDMA Band V	Test Mode :	RMC 12.2Kbps Link (QPSK)
---------------	--------------	--------------------	--------------------------

Peak-to-Average Ratio on Channel 4132 (826.4 MHz)

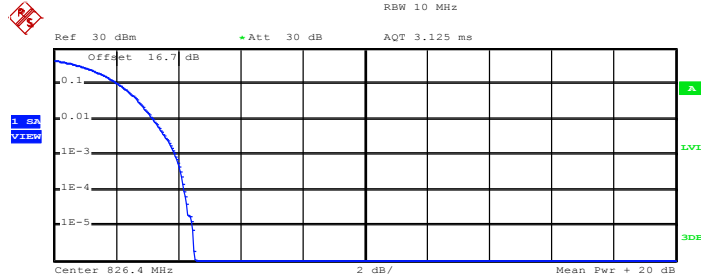

Complementary Cumulative Distribution Function (100000 samples)

Trace 1

Mean	22.76 dBm
Peak	27.29 dBm
Crest	4.53 dB
10 %	2.12 dB
1 %	3.20 dB
.1 %	3.92 dB
.01 %	4.20 dB

Date: 21.APR.2015 11:46:02

Peak-to-Average Ratio on Channel 4182 (836.4 MHz)

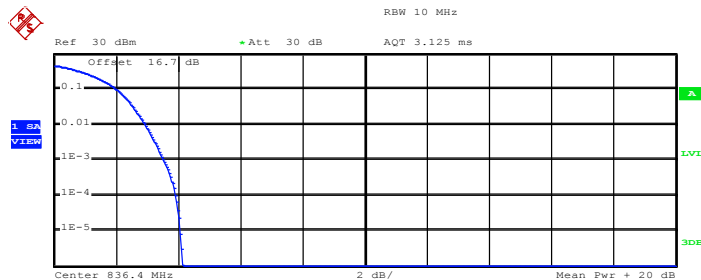

Complementary Cumulative Distribution Function (100000 samples)

Trace 1

Mean	22.17 dBm
Peak	26.30 dBm
Crest	4.13 dB
10 %	2.04 dB
1 %	2.96 dB
.1 %	3.56 dB
.01 %	3.92 dB

Date: 21.APR.2015 11:46:10



Peak-to-Average Ratio on Channel 4233 (846.6 MHz)

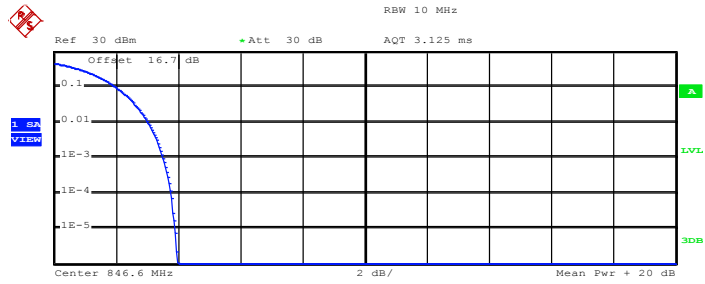

Complementary Cumulative Distribution Function (100000 samples)

Trace 1

Mean	22.26 dBm
Peak	26.23 dBm
Crest	3.97 dB
10 %	2.00 dB
1 %	3.04 dB
.1 %	3.52 dB
.01 %	3.80 dB

Date: 21.APR.2015 11:46:18



Band : WCDMA Band IV	Test Mode : RMC 12.2Kbps Link (QPSK)
-----------------------------	---

Peak-to-Average Ratio on Channel 1312 (1712.4 MHz)

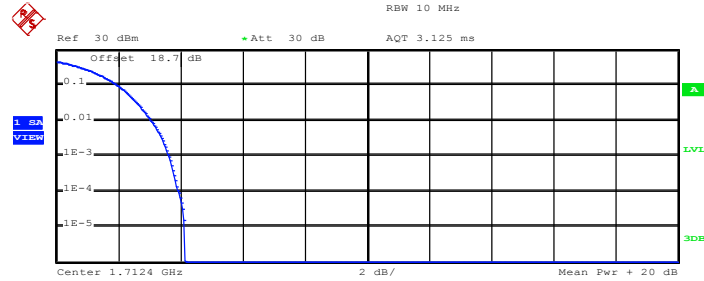

Complementary Cumulative Distribution Function (100000 samples)

Trace 1

Mean	21.38 dBm
Peak	25.53 dBm
Crest	4.15 dB
10 %	2.00 dB
1 %	3.08 dB
.1 %	3.64 dB
.01 %	3.96 dB

Date: 21.APR.2015 15:50:12

Peak-to-Average Ratio on Channel 1413 (1732.6 MHz)

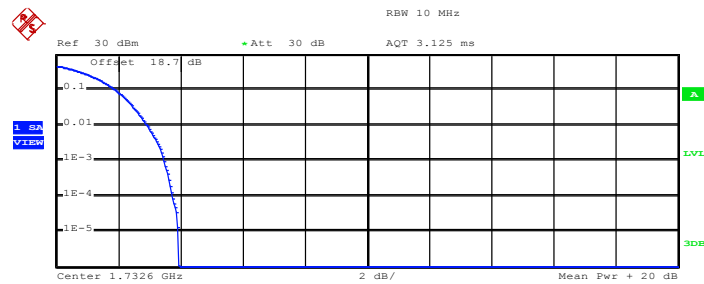

Complementary Cumulative Distribution Function (100000 samples)

Trace 1

Mean	21.87 dBm
Peak	25.81 dBm
Crest	3.94 dB
10 %	1.92 dB
1 %	2.92 dB
.1 %	3.48 dB
.01 %	3.76 dB

Date: 21.APR.2015 15:50:21



Peak-to-Average Ratio on Channel 1513 (1752.6 MHz)

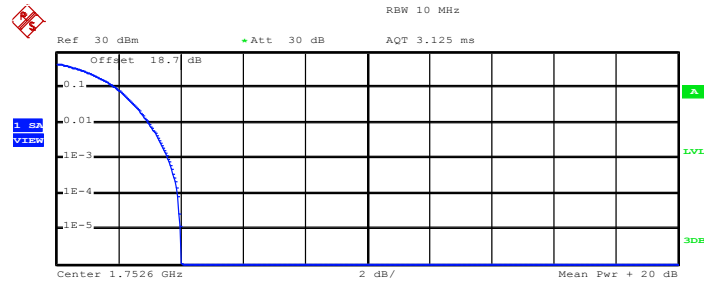

Complementary Cumulative Distribution Function (100000 samples)

Trace 1

Mean	21.01 dBm
Peak	25.03 dBm
Crest	4.02 dB
10 %	1.92 dB
1 %	2.96 dB
.1 %	3.60 dB
.01 %	3.92 dB

Date: 21.APR.2015 15:50:47



Band :	WCDMA Band II	Test Mode :	RMC 12.2Kbps Link (QPSK)
---------------	---------------	--------------------	--------------------------

Peak-to-Average Ratio on Channel 9262 (1852.4 MHz)

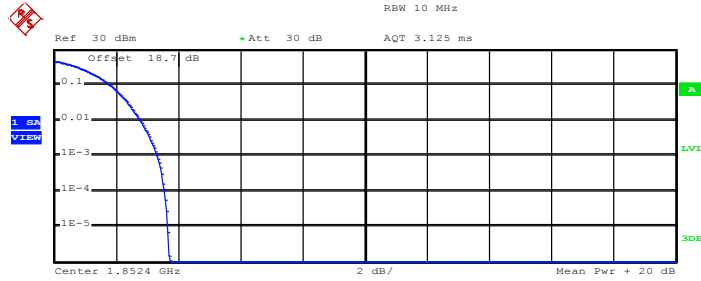

Complementary Cumulative Distribution Function (100000 samples)

Trace 1

Mean	20.82 dBm
Peak	24.54 dBm
Crest	3.72 dB
10 %	1.84 dB
1 %	2.80 dB
.1 %	3.32 dB
.01 %	3.56 dB

Date: 21.APR.2015 15:30:38

Peak-to-Average Ratio on Channel 9400 (1880.0 MHz)

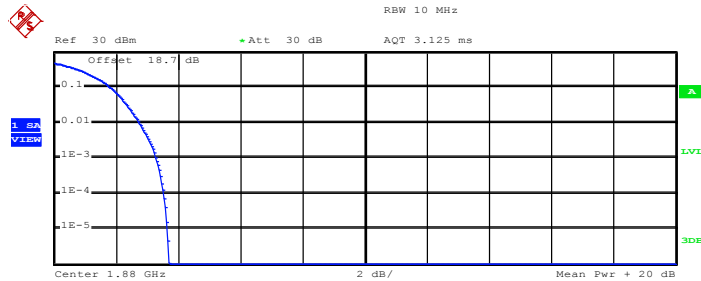

Complementary Cumulative Distribution Function (100000 samples)

Trace 1

Mean	21.27 dBm
Peak	24.96 dBm
Crest	3.69 dB
10 %	1.84 dB
1 %	2.76 dB
.1 %	3.28 dB
.01 %	3.56 dB

Date: 21.APR.2015 15:34:04



Peak-to-Average Ratio on Channel 9538 (1907.6 MHz)

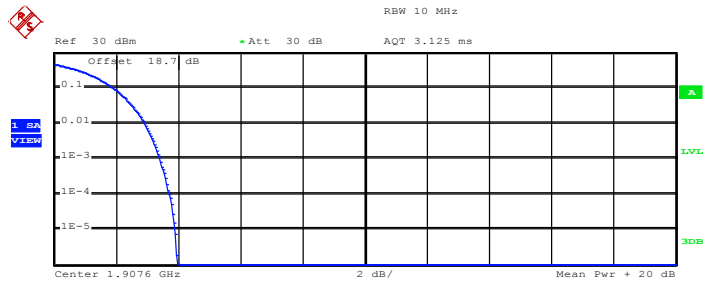

Complementary Cumulative Distribution Function (100000 samples)

Trace 1

Mean	21.00 dBm
Peak	24.96 dBm
Crest	3.97 dB
10 %	1.92 dB
1 %	2.92 dB
.1 %	3.44 dB
.01 %	3.72 dB

Date: 21.APR.2015 15:34:13



3.3 Effective Radiated Power and Effective Isotropic Radiated Power Measurement

3.3.1 Description of the ERP/EIRP Measurement

The substitution method, in ANSI / TIA / EIA-603-C-2004, was used for ERP/EIRP measurement, and the spectrum analyzer configuration follows KDB 971168 D01 Power Meas. License Digital Systems v02r02. The ERP of mobile transmitters must not exceed 7 Watts with Cellular band , the EIRP of mobile transmitters are limited to 2 Watts with PCS band and the EIRP of mobile transmitters are limited to 1 Watts with AWS band.

3.3.2 Measuring Instruments

The measuring equipment is listed in the section 4 of this test report.

3.3.3 Test Procedures

1. The testing follows FCC KDB 971168 v02r02 Section 5.2.1. (for CDMA/WCDMA), Section 5.2.2.2 (for GSM/GPRS/EDGE) and ANSI / TIA-603-C-2004 Section 2.2.17.
2. The EUT was placed on a non-conductive rotating platform 0.8 meters high in a semi-anechoic chamber. The radiated emission at the fundamental frequency was measured at 3 m with a test antenna and a spectrum analyzer with RMS detector per section 5. of KDB 971168 D01.
3. During the measurement, the system simulator parameters were set to force the EUT transmitting at maximum output power. The maximum emission was recorded from analyzer power level (LVL) from the 360 degrees rotation of the turntable and the test antenna raised and lowered over a range from 1 to 4 meters in both horizontally and vertically polarized orientations.
4. Effective Isotropic Radiated Power (EIRP) was measured by substitution method according to TIA/EIA-603-C. The EUT was replaced by the substitution antenna at same location, and then a known power from S.G. was applied into the dipole antenna through a Tx cable, and then recorded the maximum Analyzer reading through raised and lowered the test antenna. The correction factor (in dB) = S.G. - Tx Cable loss + Substitution antenna gain - Analyzer reading. Then the EUT's EIRP was calculated with the correction factor, $EIRP = LVL + \text{Correction factor}$ and $ERP = EIRP - 2.15$. Take the record of the output power at substitution antenna.

	GSM/GPRS/EDGE	WCDMA/HSPA
SPAN	500kHz	10MHz
RBW	10kHz	100kHz
VBW	30kHz	300kHz
Detector	RMS	RMS
Trace	Average	Average
Average Type	Power	Power
Sweep Count	100	100

3.3.4 Test Setup

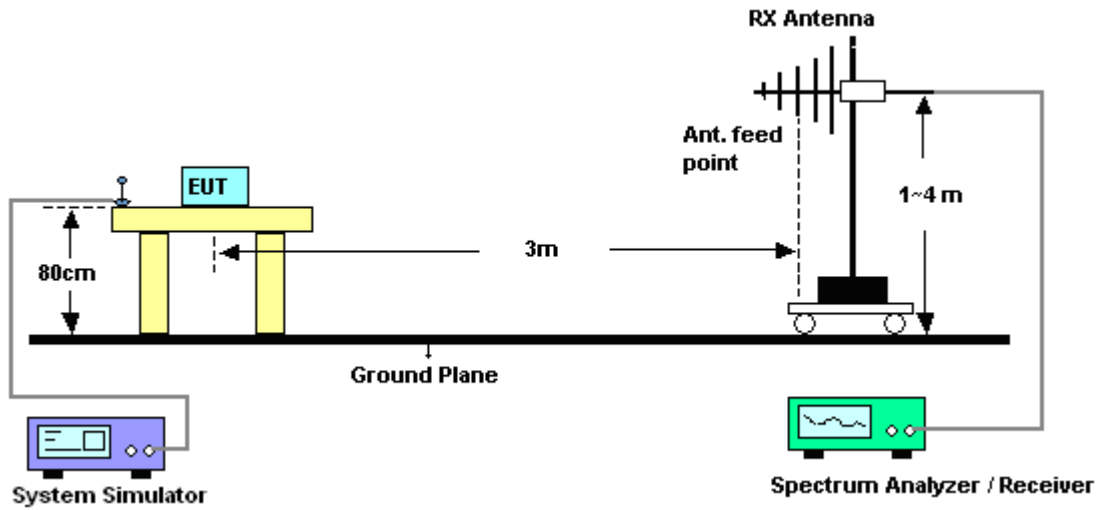



3.3.5 Test Result of ERP

GSM850 (GPRS class 8) Radiated Power ERP					
Channel	Frequency (MHz)	Horizontal		Vertical	
		ERP(dBm)	ERP(W)	ERP(dBm)	ERP(W)
Lowest	824.2	26.82	0.4808	28.37	0.6871
Middle	836.4	27.38	0.5470	29.07	0.8072
Highest	848.8	27.23	0.5284	29.26	0.8433
Limit	ERP < 7W	Result		PASS	

GSM850 (EDGE class 8) Radiated Power ERP					
Channel	Frequency (MHz)	Horizontal		Vertical	
		ERP(dBm)	ERP(W)	ERP(dBm)	ERP(W)
Lowest	824.2	20.20	0.1047	21.47	0.1403
Middle	836.4	20.54	0.1132	22.07	0.1611
Highest	848.8	20.64	0.1159	22.12	0.1629
Limit	ERP < 7W	Result		PASS	

WCDMA Band V (RMC 12.2Kbps) Radiated Power ERP					
Channel	Frequency (MHz)	Horizontal		Vertical	
		ERP(dBm)	ERP(W)	ERP(dBm)	ERP(W)
Lowest	826.4	18.01	0.0632	19.45	0.0881
Middle	836.4	16.78	0.0476	18.48	0.0705
Highest	846.6	18.66	0.0735	20.40	0.1096
Limit	ERP < 7W	Result		PASS	



3.3.6 Test Result of EIRP

GSM1900 (GPRS class 8) Radiated Power EIRP					
Channel	Frequency (MHz)	Horizontal		Vertical	
		EIRP(dBm)	EIRP(W)	EIRP(dBm)	EIRP(W)
Lowest	1850.2	30.69	1.1722	29.15	0.8222
Middle	1880.0	31.05	1.2735	29.63	0.9183
Highest	1909.8	30.59	1.1455	29.19	0.8299
Limit	EIRP < 2W	Result		PASS	

GSM1900 (EDGE class 8) Radiated Power EIRP					
Channel	Frequency (MHz)	Horizontal		Vertical	
		EIRP(dBm)	EIRP(W)	EIRP(dBm)	EIRP(W)
Lowest	1850.2	24.86	0.3062	23.70	0.2344
Middle	1880.0	25.47	0.3524	23.87	0.2438
Highest	1909.8	25.03	0.3184	23.66	0.2323
Limit	EIRP < 2W	Result		PASS	

WCDMA Band II (RMC 12.2Kbps) Radiated Power EIRP					
Channel	Frequency (MHz)	Horizontal		Vertical	
		EIRP(dBm)	EIRP(W)	EIRP(dBm)	EIRP(W)
Lowest	1852.4	22.93	0.1963	21.43	0.1390
Middle	1880.0	22.75	0.1884	21.32	0.1355
Highest	1907.6	22.96	0.1977	21.48	0.1406
Limit	EIRP < 2W	Result		PASS	

WCDMA Band IV(RMC 12.2Kbps) Radiated Power EIRP					
Channel	Frequency (MHz)	Horizontal		Vertical	
		EIRP(dBm)	EIRP(W)	EIRP(dBm)	EIRP(W)
Lowest	1712.4	20.84	0.1213	19.33	0.0857
Middle	1732.6	21.48	0.1406	20.07	0.1016
Highest	1752.6	21.78	0.1507	20.20	0.1047
Limit	EIRP < 1W	Result		PASS	

3.4 99% Occupied Bandwidth and 26dB Bandwidth Measurement

3.4.1 Description of 99% Occupied Bandwidth and 26dB Bandwidth Measurement

The 99% occupied bandwidth is the width of a frequency band such that, below the lower and above the upper frequency limits, the mean powers emitted are each equal to a specified percentage 0.5% of the total mean transmitted power.

The emission bandwidth is defined as the width of the signal between two points, located at the 2 sides of the carrier frequency, outside of which all emissions are attenuated at least 26 dB below the transmitter power.

3.4.2 Measuring Instruments

The measuring equipment is listed in the section 4 of this test report.

3.4.3 Test Procedures

1. The testing follows FCC KDB 971168 v02r02 Section 4.2.
2. The EUT was connected to the spectrum analyzer and system simulator via a power divider.
3. The RF output of the EUT was connected to the spectrum analyzer by RF cable and attenuator. The path loss was compensated to the results for each measurement.
4. The 99% occupied bandwidth were measured, set RBW= 1% of span, VBW= 3*RBW, sample detector, trace maximum hold.
5. The 26dB bandwidth were measured, set RBW= 1% of EBW, VBW= 3*RBW, peak detector, trace maximum hold.

3.4.4 Test Setup

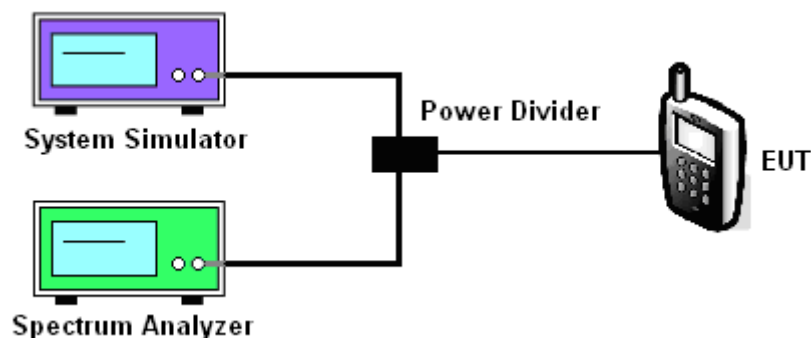



3.4.5 Test Result of Occupied Bandwidth and 26dB Bandwidth

Cellular Band						
Modes	GSM850 (GPRS class 8)			GSM850 (EDGE class 8)		
Channel	128 (Low)	189 (Mid)	251 (High)	128 (Low)	189 (Mid)	251 (High)
Frequency (MHz)	824.2	836.4	848.8	824.2	836.4	848.8
99% OBW (kHz)	244.00	247.00	243.00	245.00	243.00	245.00
26dB BW (kHz)	305.00	313.00	312.00	300.00	300.00	291.00

PCS Band						
Modes	GSM1900 (GPRS class 8)			GSM1900 (EDGE class 8)		
Channel	512 (Low)	661 (Mid)	810 (High)	512 (Low)	661 (Mid)	810 (High)
Frequency (MHz)	1850.2	1880	1909.8	1850.2	1880	1909.8
99% OBW (kHz)	249.00	246.00	246.00	242.00	243.00	249.00
26dB BW (kHz)	301.00	314.00	314.00	302.00	301.00	303.00

Cellular Band			
Modes	WCDMA Band V (RMC 12.2Kbps)		
Channel	4132 (Low)	4182 (Mid)	4233 (High)
Frequency (MHz)	826.4	836.4	846.6
99% OBW (MHz)	4.13	4.15	4.13
26dB BW (MHz)	4.69	4.73	4.70

PCS Band			
Modes	WCDMA Band II (RMC 12.2Kbps)		
Channel	9262 (Low)	9400 (Mid)	9538 (High)
Frequency (MHz)	1852.4	1880	1907.6
99% OBW (MHz)	4.16	4.15	4.16
26dB BW (MHz)	4.70	4.71	4.71

AWS Band			
Modes	WCDMA Band IV (RMC 12.2Kbps)		
Channel	1312(Low)	1413 (Mid)	1513 (High)
Frequency (MHz)	1712.4	1732.6	1752.6
99% OBW (MHz)	4.14	4.13	4.14
26dB BW (MHz)	4.72	4.68	4.71



3.4.6 Test Result (Plots) of Occupied Bandwidth and 26dB Bandwidth

Band :	GSM 850	Test Mode :	GPRS class 8 Link (GMSK)
--------	---------	-------------	--------------------------

99% Occupied Bandwidth Plot on Channel 128 (824.2 MHz)

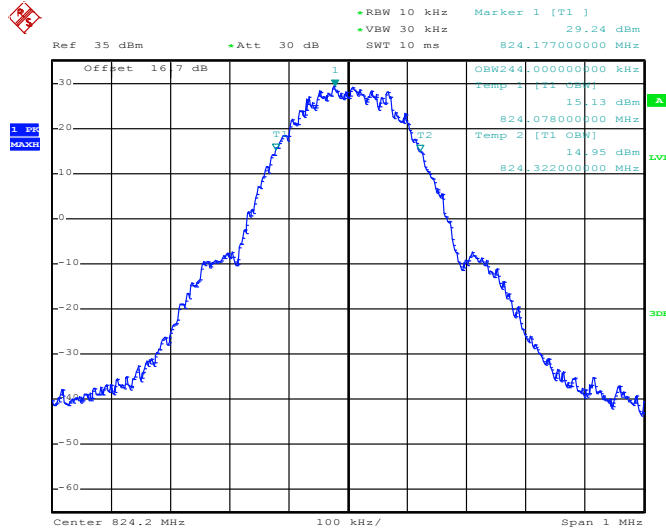

Date: 28.APR.2015 10:13:31

26dB Bandwidth Plot on Channel 128 (824.2 MHz)

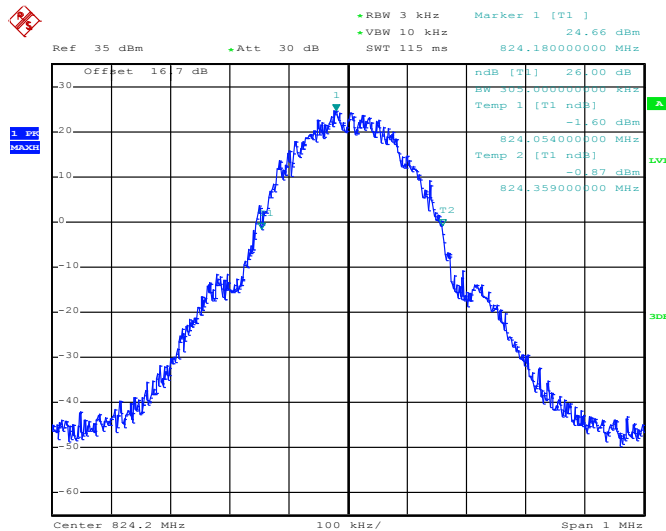

Date: 28.APR.2015 10:11:25



99% Occupied Bandwidth Plot on Channel 189 (836.4 MHz)

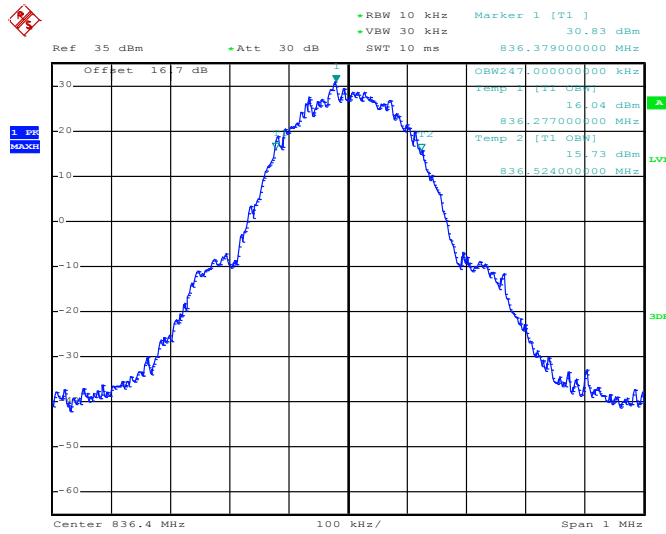

Date: 28.APR.2015 10:14:12

26dB Bandwidth Plot on Channel 189 (836.4 MHz)

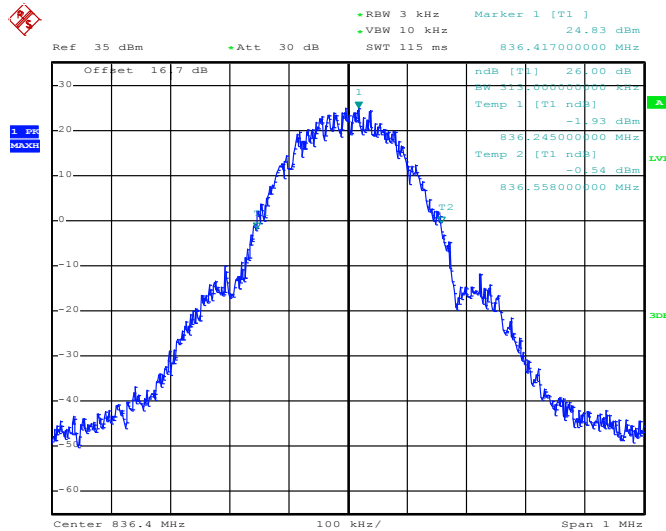

Date: 28.APR.2015 10:12:03



99% Occupied Bandwidth Plot on Channel 251 (848.8 MHz)

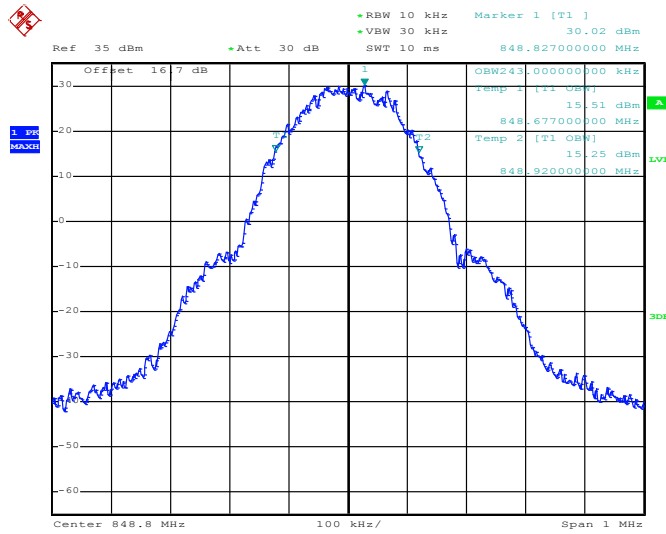

Date: 28.APR.2015 10:14:45

26dB Bandwidth Plot on Channel 251 (848.8 MHz)

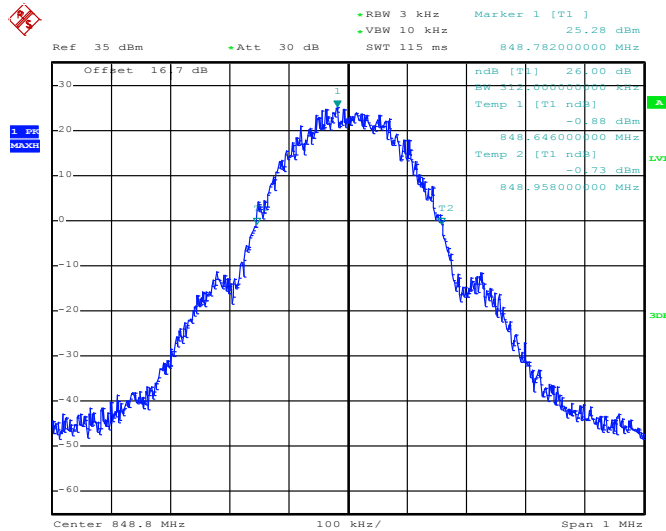

Date: 28.APR.2015 10:12:37



Band :	GSM 850	Test Mode :	EDGE class 8 Link (8PSK)
---------------	---------	--------------------	--------------------------

99% Occupied Bandwidth Plot on Channel 128 (824.2 MHz)

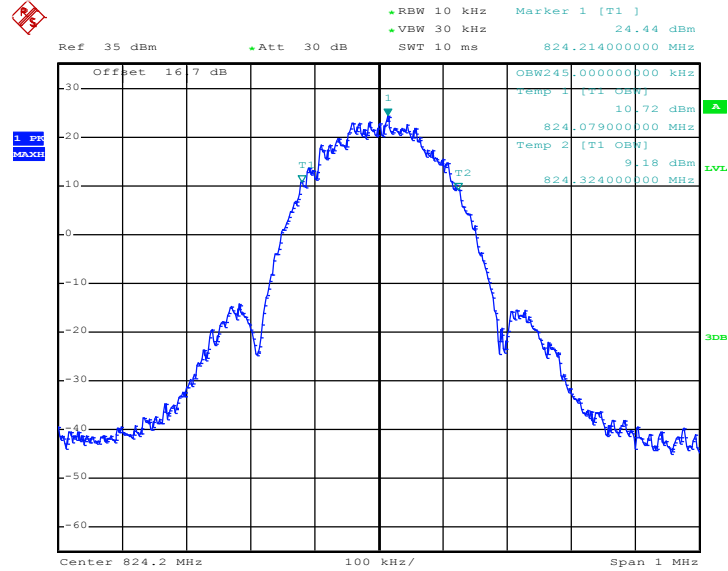

Date: 28.APR.2015 10:28:39

26dB Bandwidth Plot on Channel 128 (824.2 MHz)

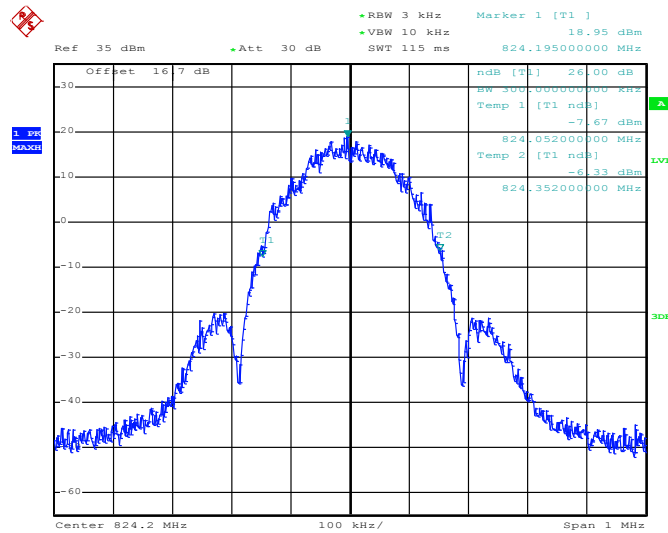

Date: 28.APR.2015 10:26:28



99% Occupied Bandwidth Plot on Channel 189 (836.4 MHz)

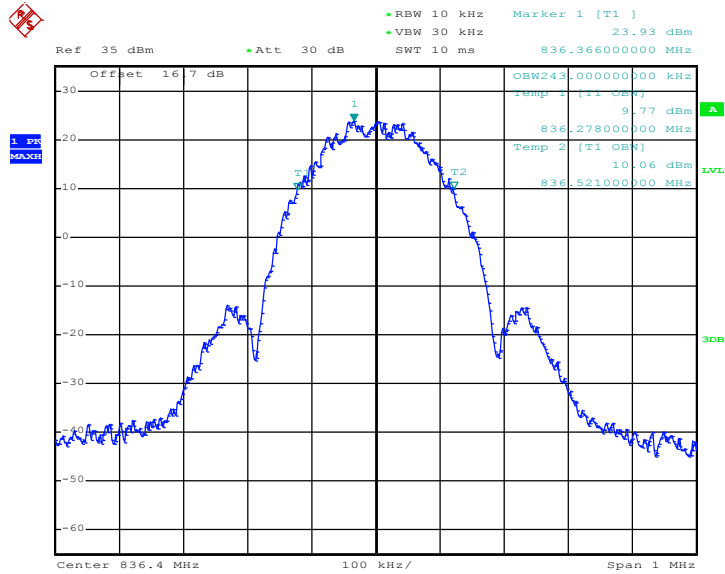

Date: 28.APR.2015 10:29:09

26dB Bandwidth Plot on Channel 189 (836.4 MHz)

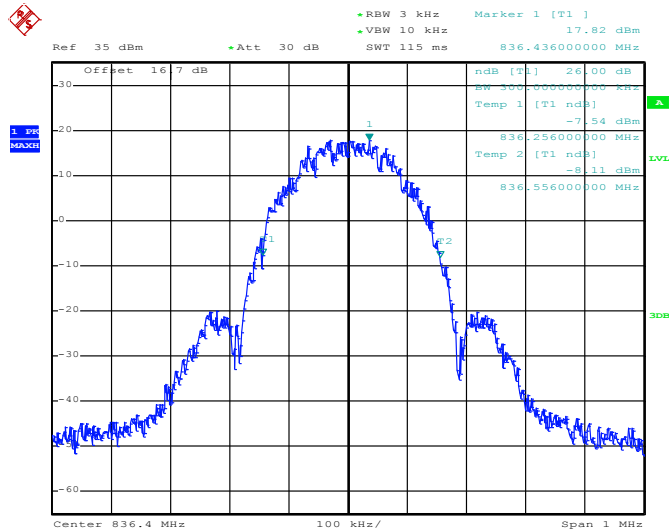

Date: 28.APR.2015 10:27:18



99% Occupied Bandwidth Plot on Channel 251 (848.8 MHz)

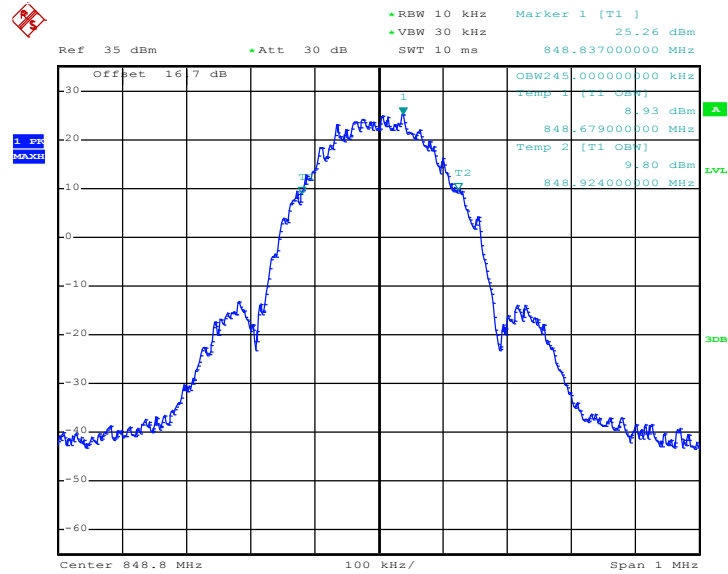

Date: 28.APR.2015 10:29:38

26dB Bandwidth Plot on Channel 251 (848.8 MHz)

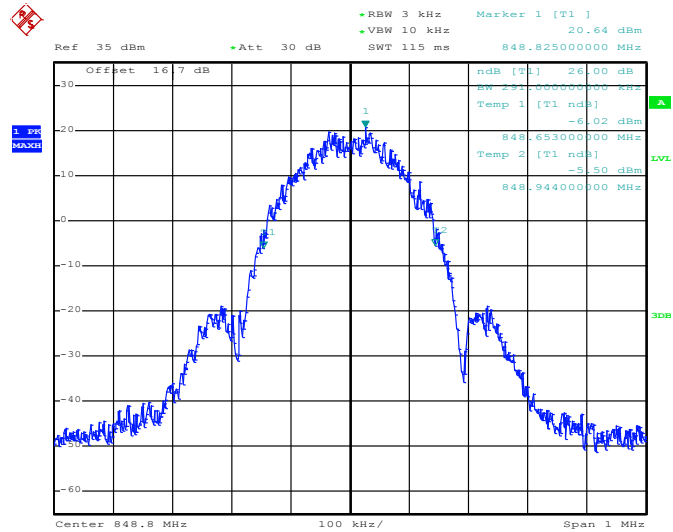

Date: 28.APR.2015 10:27:51



Band :	GSM 1900	Test Mode :	GPRS class 8 Link (GMSK)
---------------	----------	--------------------	--------------------------

99% Occupied Bandwidth Plot on Channel 512 (1850.2 MHz)

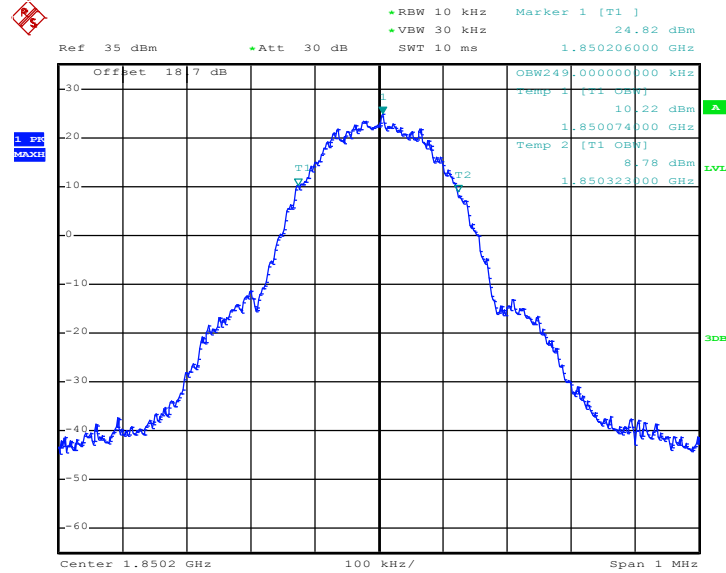

Date: 28.APR.2015 14:12:14

26dB Bandwidth Plot on Channel 512 (1850.2 MHz)

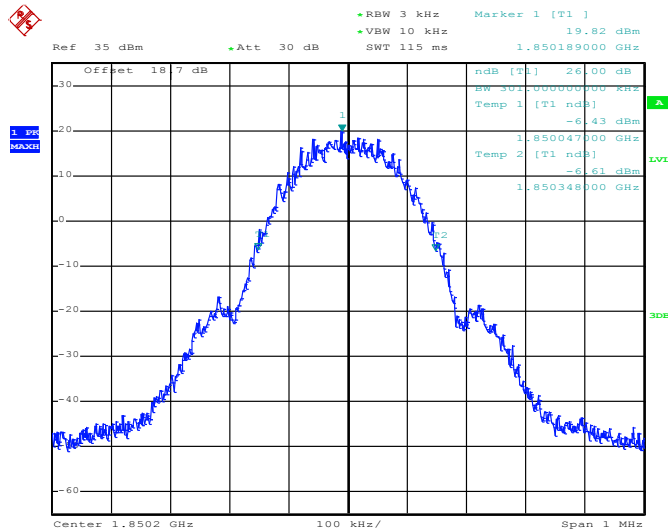

Date: 28.APR.2015 14:09:43



99% Occupied Bandwidth Plot on Channel 661 (1880.0 MHz)

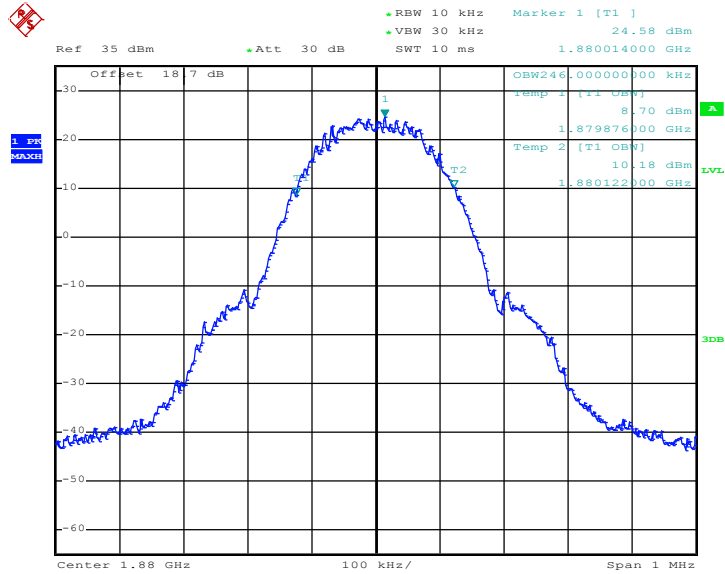

Date: 28.APR.2015 14:12:42

26dB Bandwidth Plot on Channel 661 (1880.0 MHz)

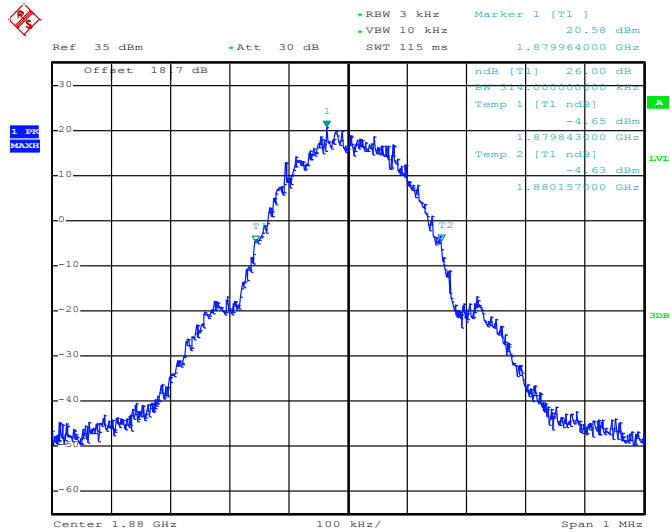

Date: 28.APR.2015 14:10:11



99% Occupied Bandwidth Plot on Channel 810 (1909.8 MHz)

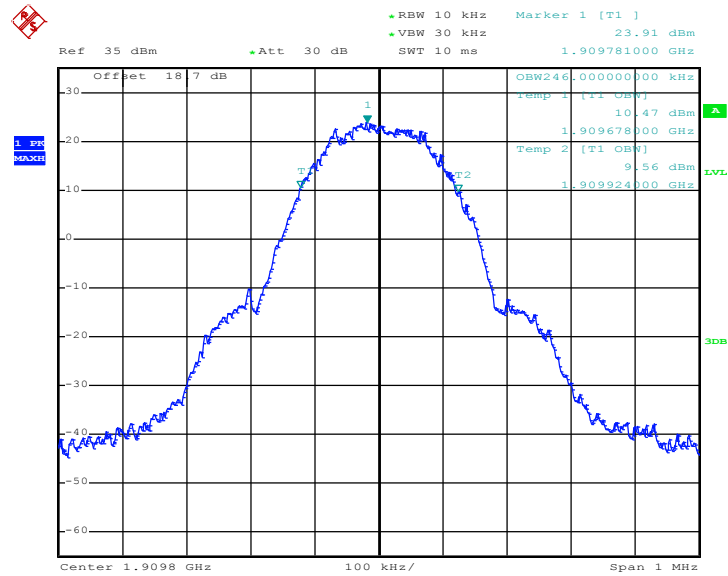

Date: 28.APR.2015 14:13:10

26dB Bandwidth Plot on Channel 810 (1909.8 MHz)

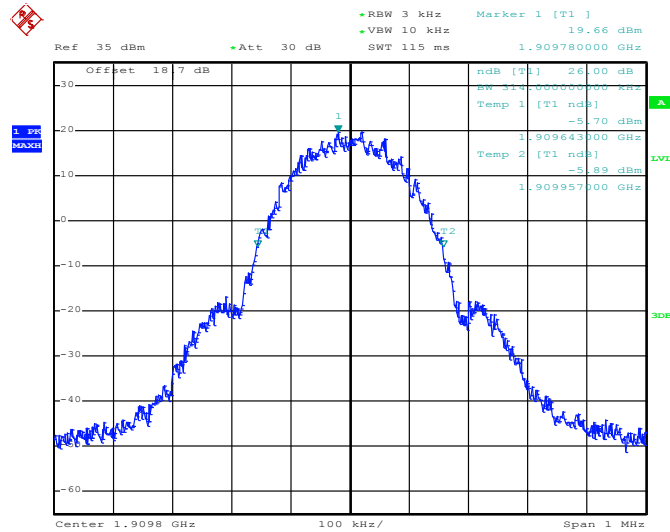

Date: 28.APR.2015 14:10:39



Band :	GSM 1900	Test Mode :	EDGE class 8 Link (8PSK)
---------------	----------	--------------------	--------------------------

99% Occupied Bandwidth Plot on Channel 512 (1850.2 MHz)

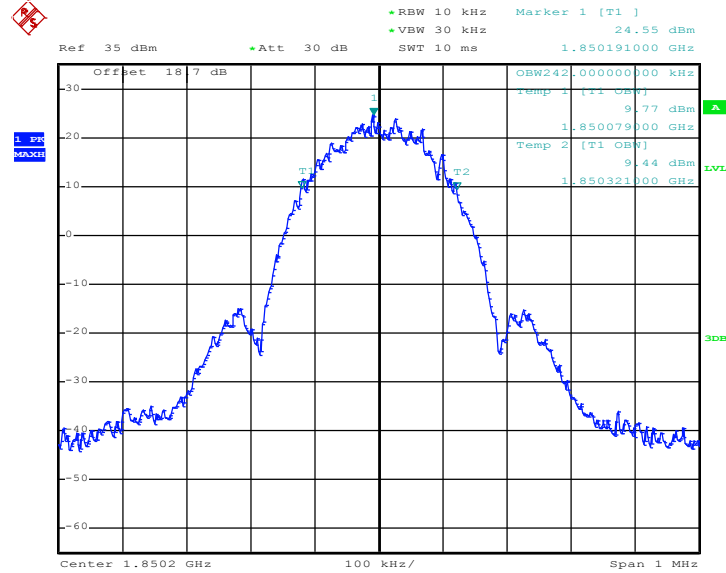

Date: 28.APR.2015 13:55:29

26dB Bandwidth Plot on Channel 512 (1850.2 MHz)

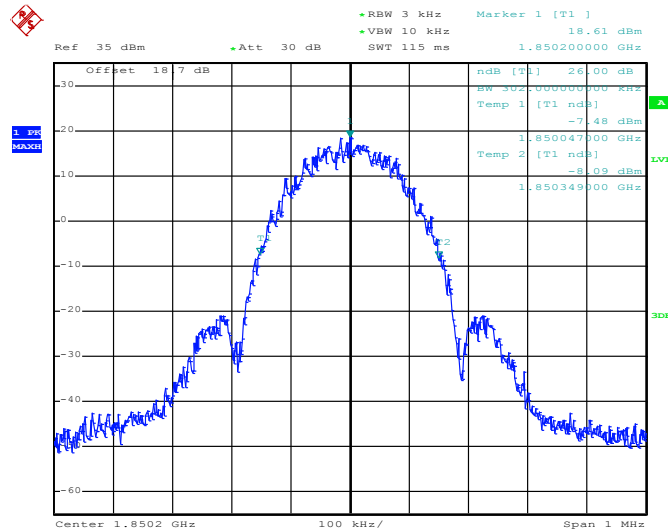

Date: 28.APR.2015 13:53:26



99% Occupied Bandwidth Plot on Channel 661 (1880.0 MHz)

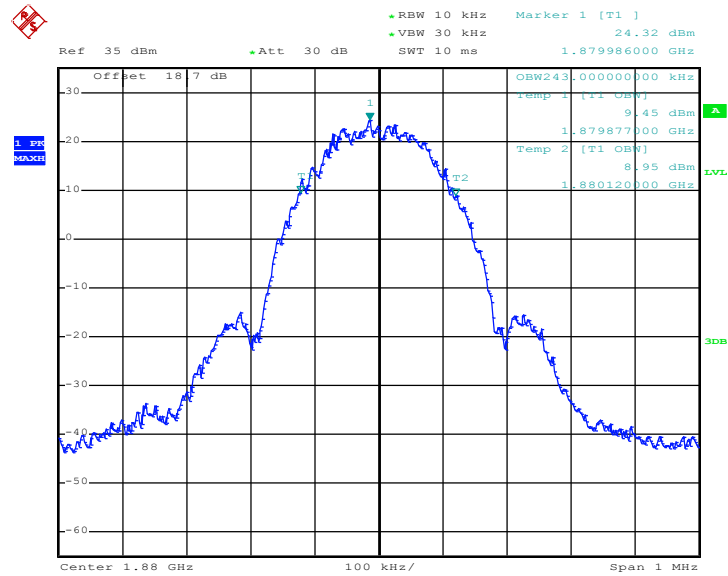

Date: 28.APR.2015 13:56:38

26dB Bandwidth Plot on Channel 661 (1880.0 MHz)

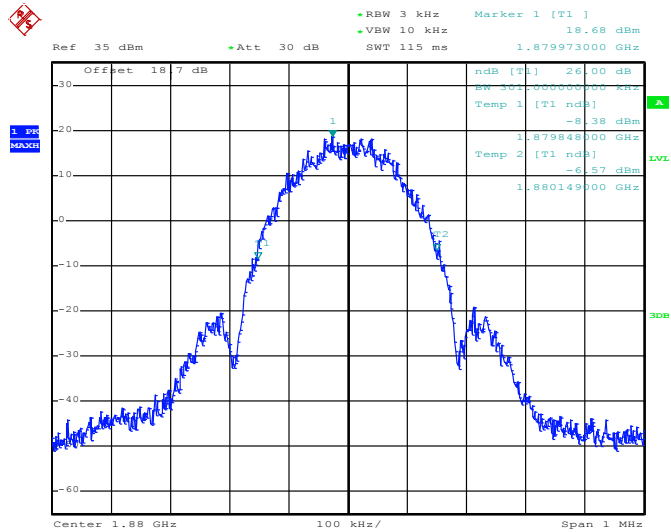

Date: 28.APR.2015 13:53:59



99% Occupied Bandwidth Plot on Channel 810 (1909.8 MHz)

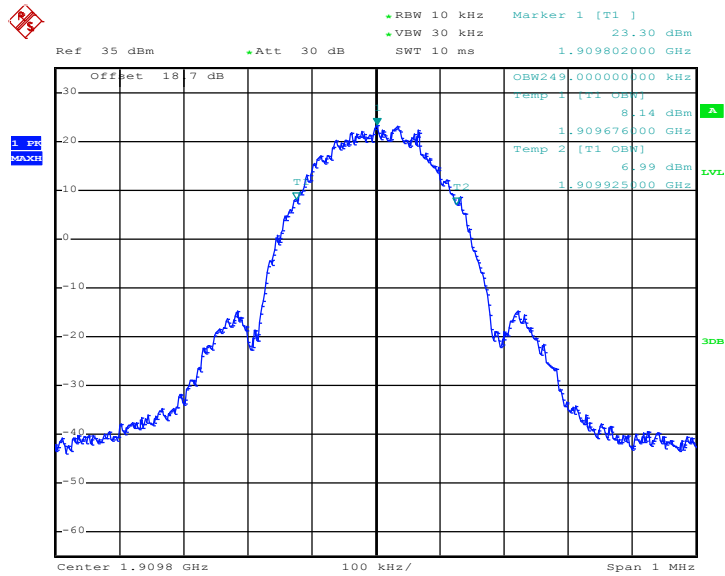

Date: 28.APR.2015 13:57:12

26dB Bandwidth Plot on Channel 810 (1909.8 MHz)

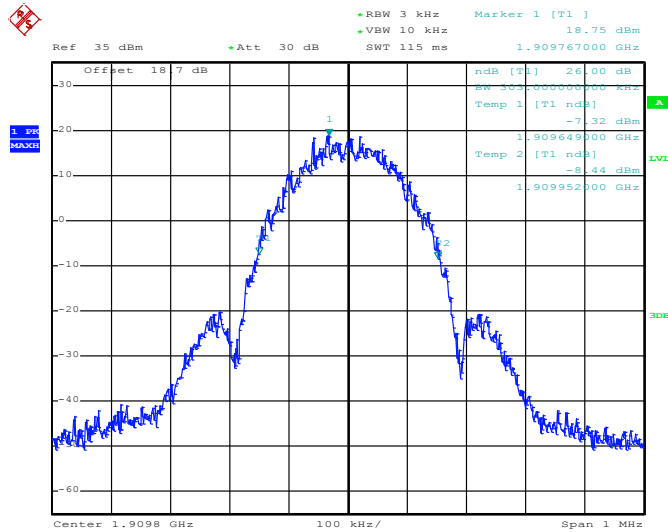

Date: 28.APR.2015 13:54:31



Band :	WCDMA Band V	Test Mode :	RMC 12.2Kbps Link (QPSK)
---------------	--------------	--------------------	--------------------------

99% Occupied Bandwidth Plot on Channel 4132 (826.4 MHz)

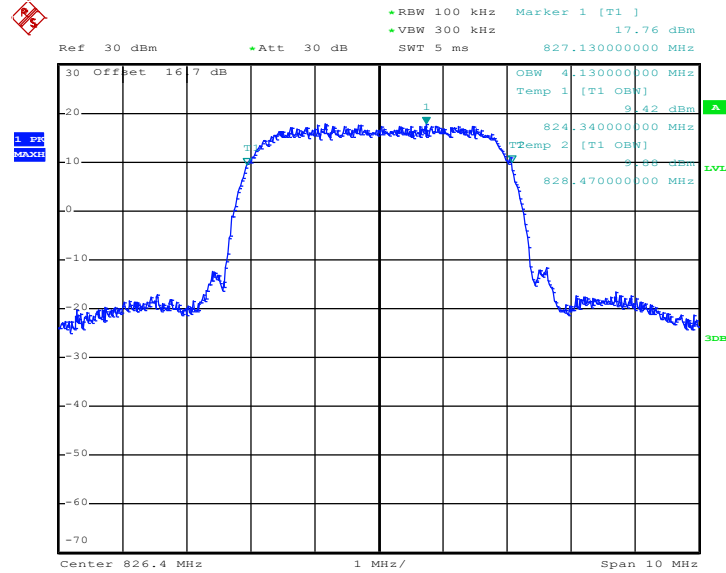

Date: 21.APR.2015 11:41:47

26dB Bandwidth Plot on Channel 4132 (826.4 MHz)

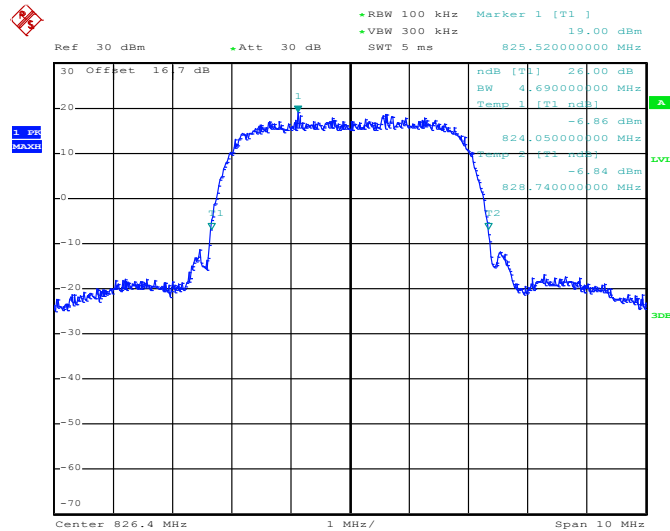

Date: 21.APR.2015 11:40:13



99% Occupied Bandwidth Plot on Channel 4182 (836.4 MHz)

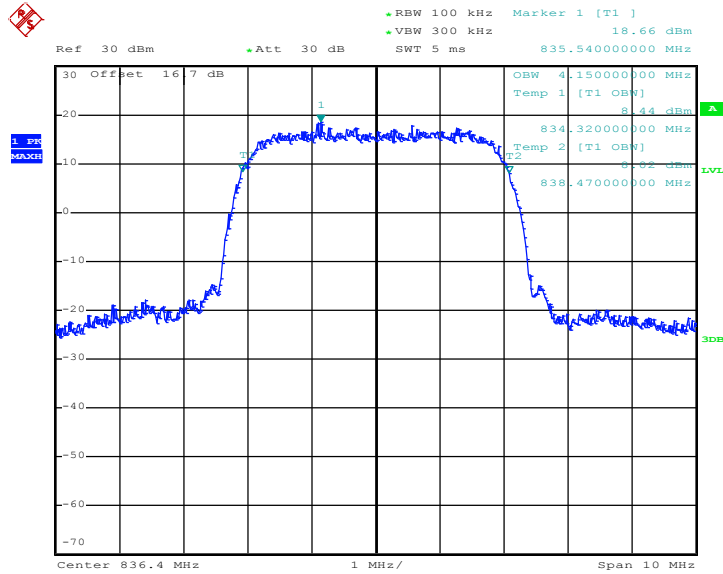

Date: 21.APR.2015 11:42:15

26dB Bandwidth Plot on Channel 4182 (836.4 MHz)

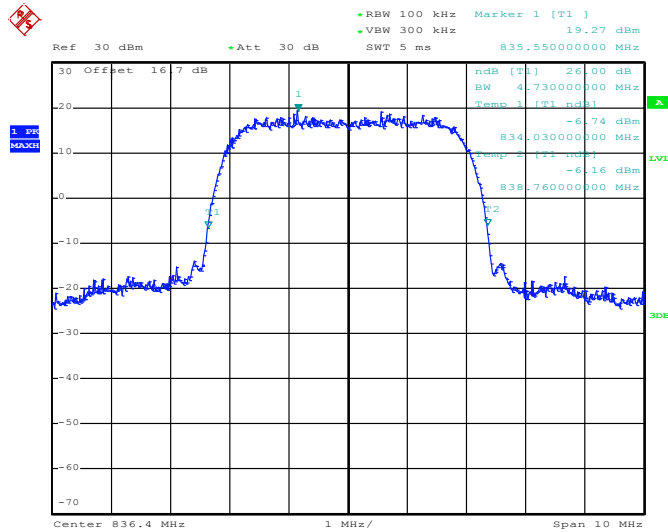

Date: 21.APR.2015 11:40:41



99% Occupied Bandwidth Plot on Channel 4233 (846.6 MHz)

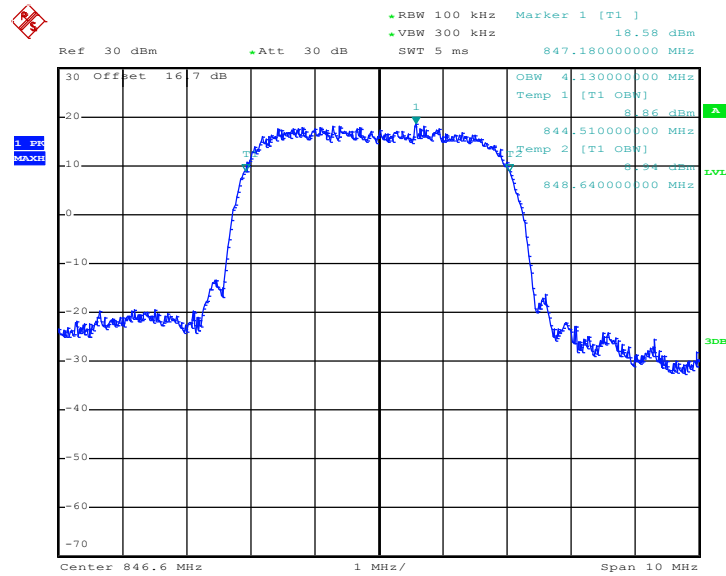

Date: 21.APR.2015 11:42:43

26dB Bandwidth Plot on Channel 4233 (846.6 MHz)

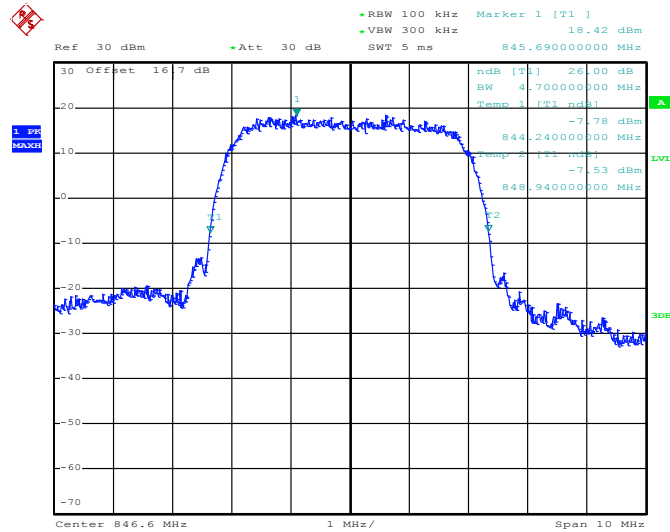

Date: 21.APR.2015 11:41:09



Band :	WCDMA Band IV	Test Mode :	RMC 12.2Kbps Link (QPSK)
---------------	---------------	--------------------	--------------------------

99% Occupied Bandwidth Plot on Channel 1312 (1712.4 MHz)

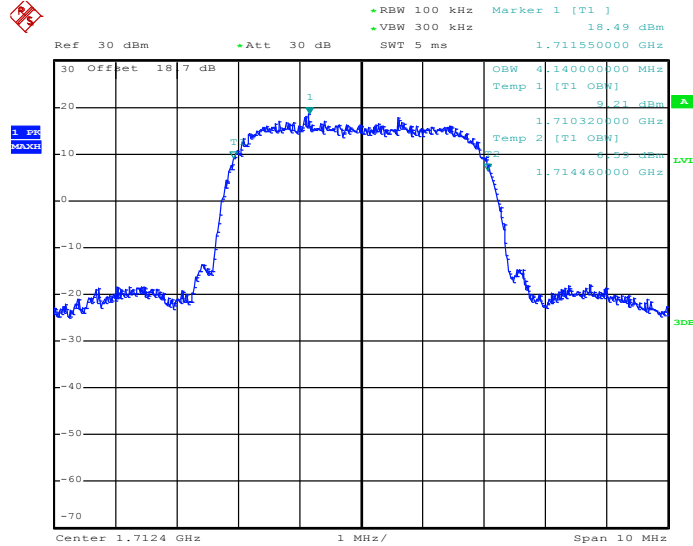

Date: 21.APR.2015 15:43:03

26dB Bandwidth Plot on Channel 1312 (1712.4 MHz)

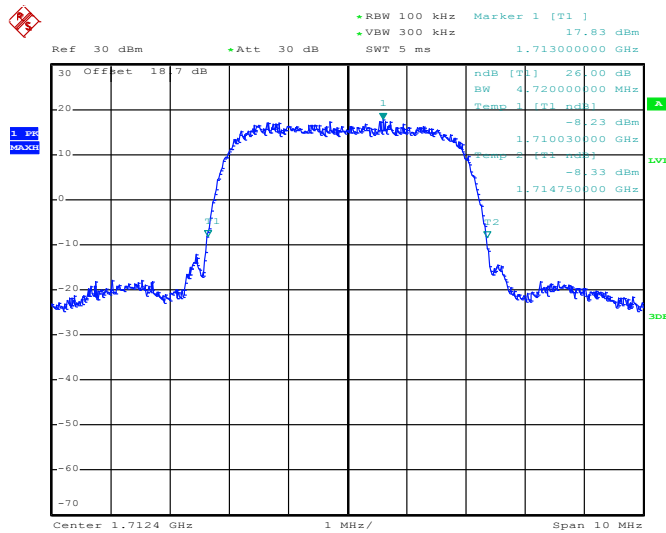

Date: 21.APR.2015 15:37:01



99% Occupied Bandwidth Plot on Channel 1413 (1732.6 MHz)

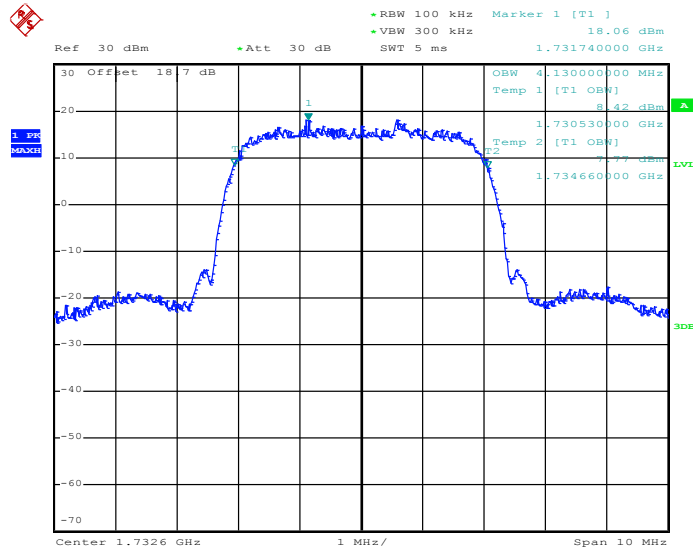

Date: 21.APR.2015 15:43:31

26dB Bandwidth Plot on Channel 1413 (1732.6 MHz)

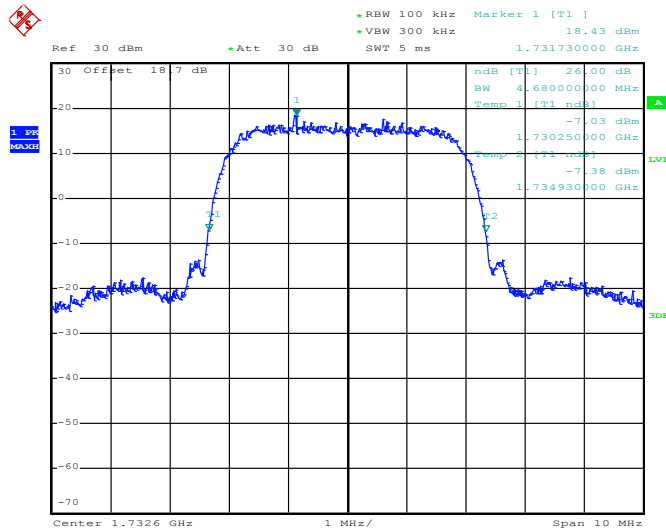

Date: 21.APR.2015 15:37:29



99% Occupied Bandwidth Plot on Channel 1513 (1752.6 MHz)

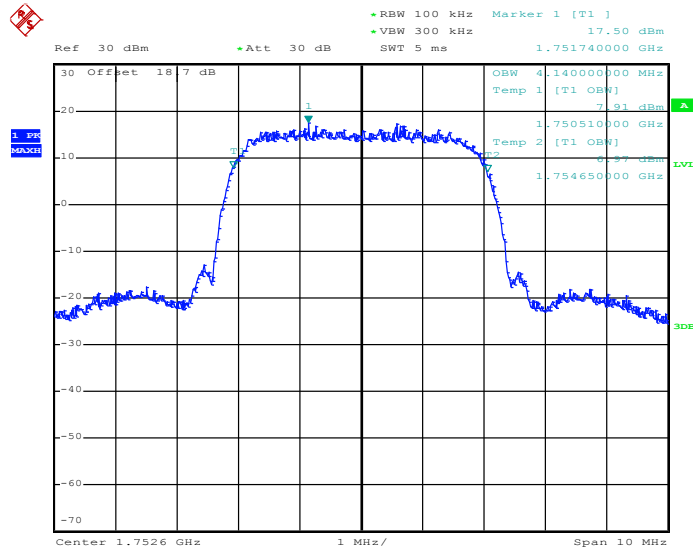

Date: 21.APR.2015 15:43:59

26dB Bandwidth Plot on Channel 1513 (1752.6 MHz)

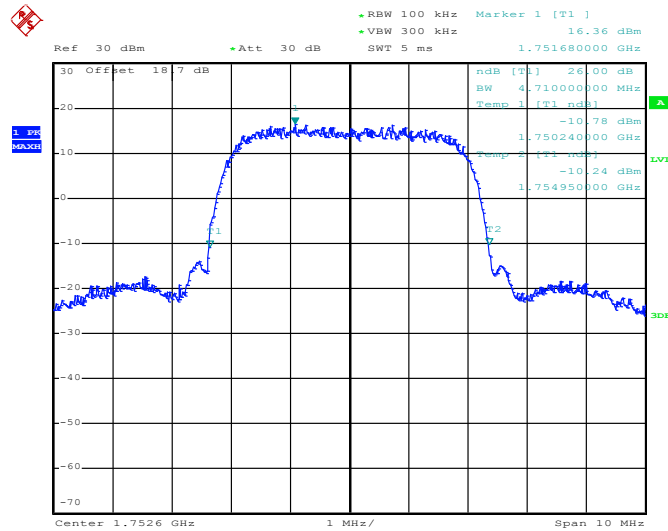

Date: 21.APR.2015 15:37:57



Band :	WCDMA Band II	Test Mode :	RMC 12.2Kbps Link (QPSK)
---------------	---------------	--------------------	--------------------------

99% Occupied Bandwidth Plot on Channel 9262 (1852.4 MHz)

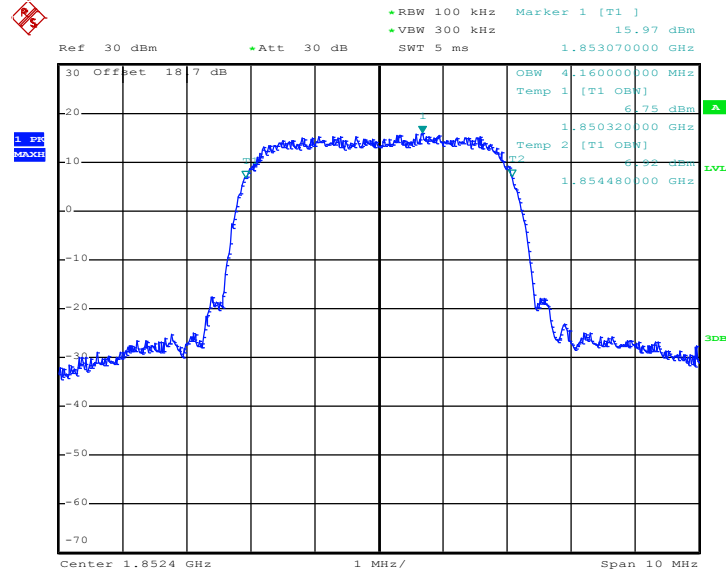

Date: 21.APR.2015 15:23:45

26dB Bandwidth Plot on Channel 9262 (1852.4 MHz)

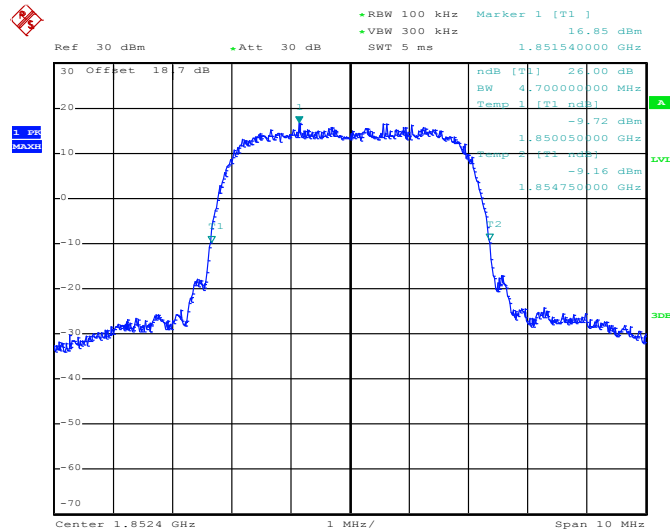

Date: 21.APR.2015 15:22:11



99% Occupied Bandwidth Plot on Channel 9400 (1880.0 MHz)

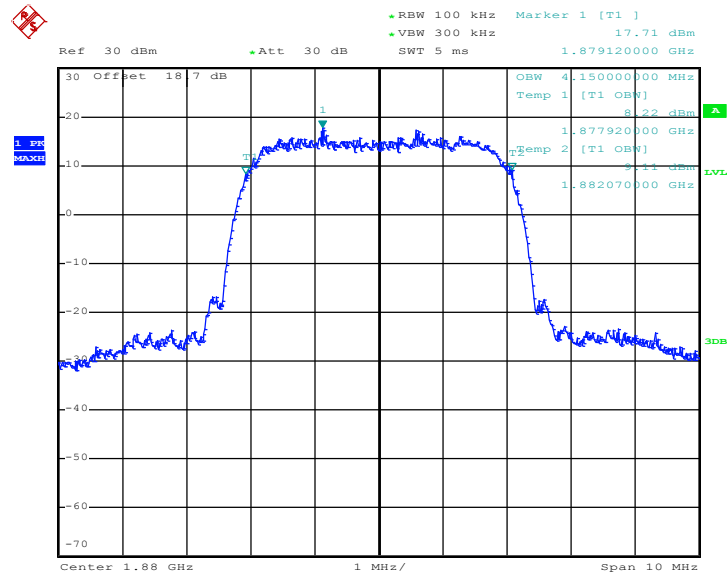

Date: 21.APR.2015 15:24:13

26dB Bandwidth Plot on Channel 9400 (1880.0 MHz)

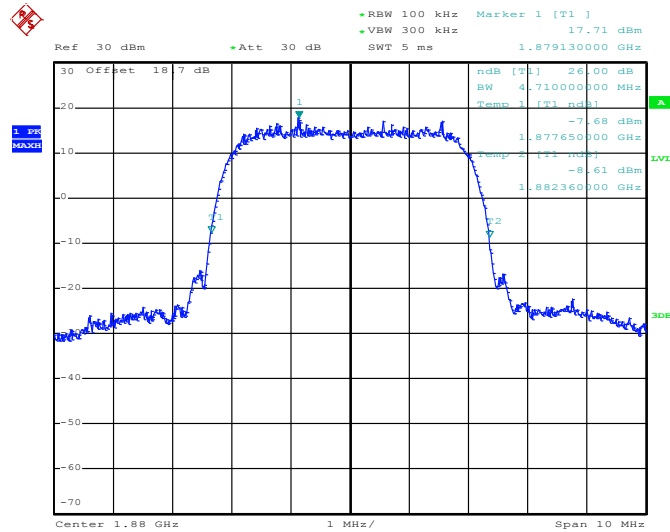

Date: 21.APR.2015 15:22:39



99% Occupied Bandwidth Plot on Channel 9538 (1907.6 MHz)

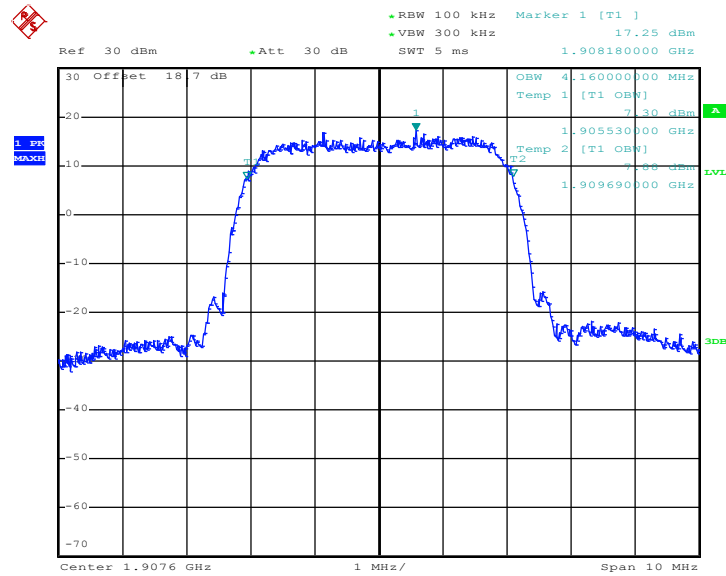

Date: 21.APR.2015 15:24:41

26dB Bandwidth Plot on Channel 9538 (1907.6 MHz)

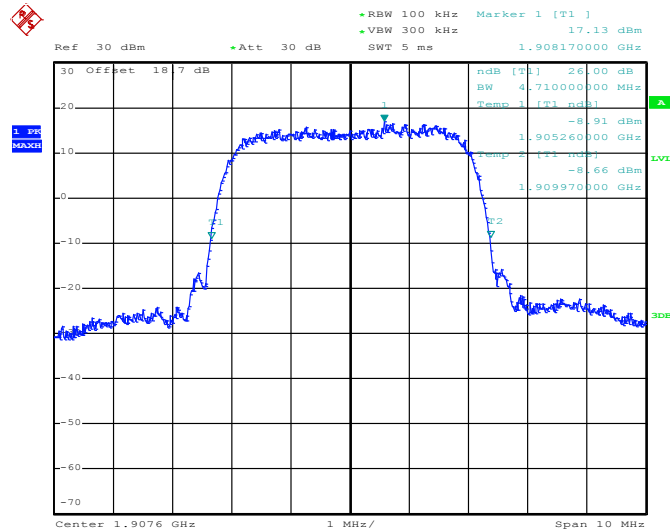

Date: 21.APR.2015 15:23:07

3.5 Band Edge Measurement

3.5.1 Description of Band Edge Measurement

The power of any emission outside of the authorized operating frequency ranges must be lower than the transmitter power (P) by a factor of at least $43 + 10 \log (P)$ dB.

3.5.2 Measuring Instruments

The measuring equipment is listed in the section 4 of this test report.

3.5.3 Test Procedures

1. The testing follows FCC KDB 971168 v02r02 Section 6.0.
2. The EUT was connected to the spectrum analyzer and system simulator via a power divider.
3. The RF output of EUT was connected to the spectrum analyzer by an RF cable and attenuator. The path loss was compensated to the results for each measurement.
4. The band edges of low and high channels for the highest RF powers were measured.
5. The RF fundamental frequency should be excluded against the limit line in the operating frequency band.
6. The limit line is derived from $43 + 10\log(P)$ dB below the transmitter power P(Watts)
 $= P(W) - [43 + 10\log(P)]$ (dB)
 $= [30 + 10\log(P)]$ (dBm) - $[43 + 10\log(P)]$ (dB)
 $= -13\text{dBm}$.

3.5.4 Test Setup

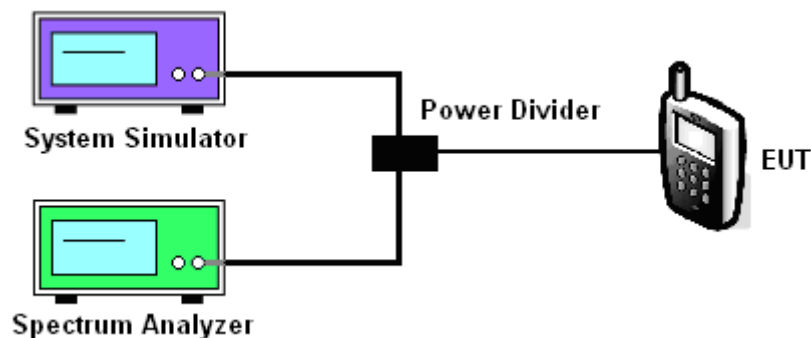



3.5.5 Test Result (Plots) of Conducted Band Edge

Band :	GSM850	Test Mode :	GPRS class 8 Link (GMSK)
--------	--------	-------------	--------------------------

Lower Band Edge Plot on Channel 128 (824.2 MHz)

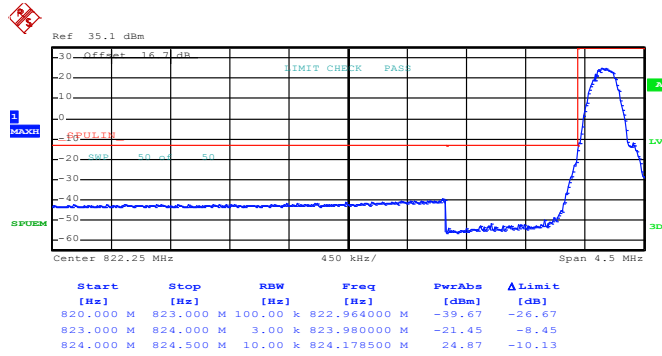

Date: 28.APR.2015 10:16:48

Higher Band Edge Plot on Channel 251 (848.8 MHz)

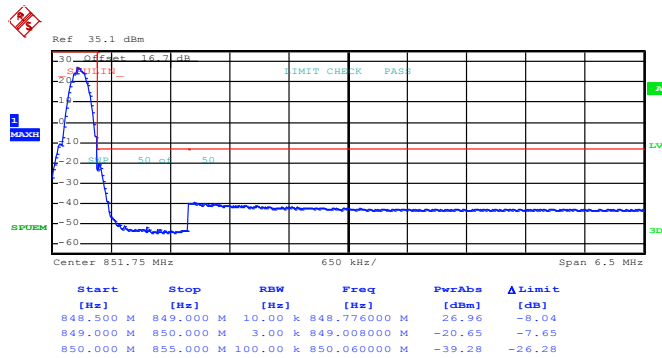

Date: 28.APR.2015 10:18:18



Band :	GSM850	Test Mode :	EDGE class 8 Link (8PSK)
--------	--------	-------------	--------------------------

Lower Band Edge Plot on Channel 128 (824.2 MHz)

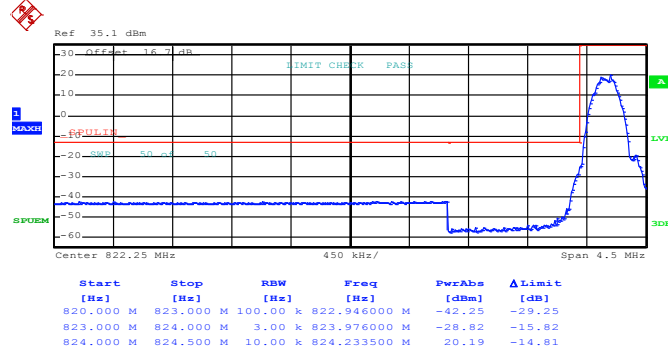

Date: 28.APR.2015 10:31:11

Higher Band Edge Plot on Channel 251 (848.8 MHz)

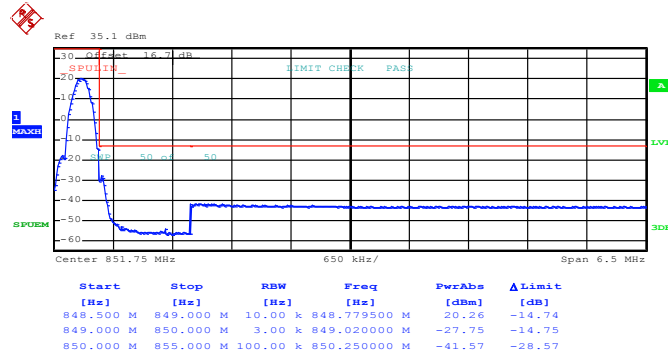

Date: 28.APR.2015 10:32:28



Band : GSM1900	Test Mode : GPRS class 8 Link (GMSK)
----------------	--------------------------------------

Lower Band Edge Plot on Channel 512 (1850.2 MHz)

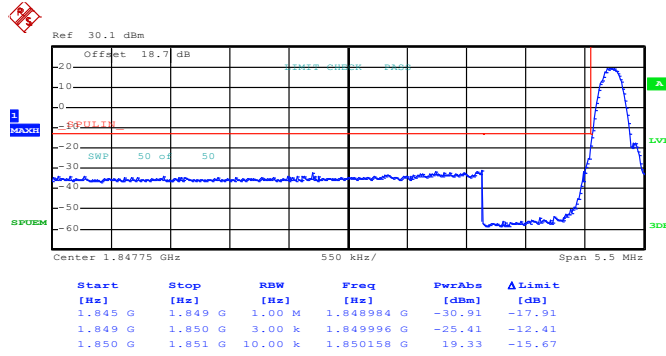

Date: 28.APR.2015 14:14:51

Higher Band Edge Plot on Channel 810 (1909.8 MHz)

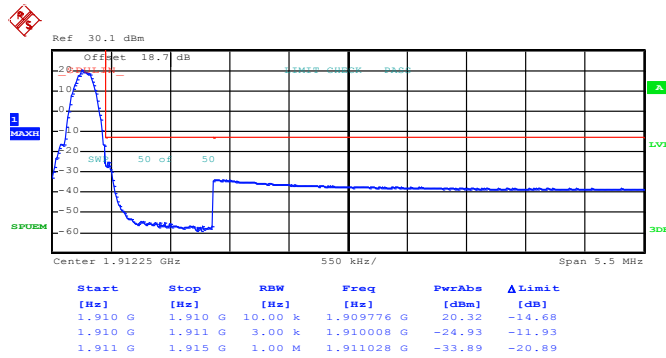

Date: 28.APR.2015 14:16:03



Band : GSM1900	Test Mode : EDGE class 8 Link (8PSK)
----------------	--------------------------------------

Lower Band Edge Plot on Channel 512 (1850.2 MHz)

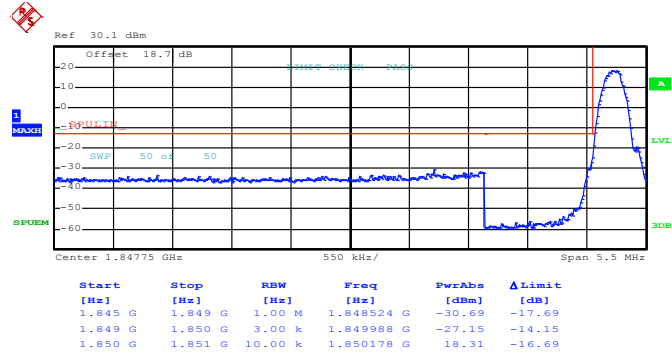

Date: 28.APR.2015 13:58:37

Higher Band Edge Plot on Channel 810 (1909.8 MHz)

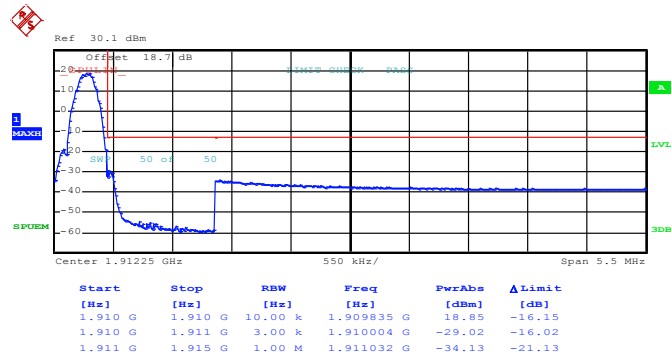

Date: 28.APR.2015 13:59:59



Band : WCDMA Band V

Test Mode : RMC 12.2Kbps Link (QPSK)

Lower Band Edge Plot on Channel 4132 (826.4 MHz)

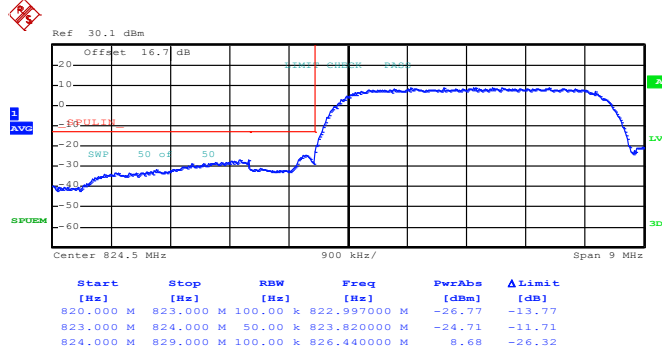

Date: 21.APR.2015 11:44:15

Higher Band Edge Plot on Channel 4233 (846.6 MHz)

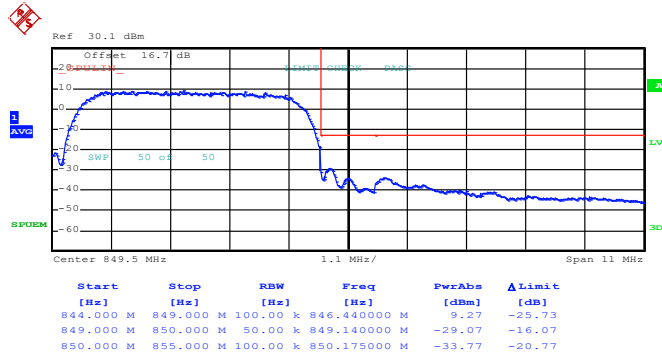

Date: 21.APR.2015 11:45:27



Band : WCDMA Band IV	Test Mode : RMC 12.2Kbps Link (QPSK)
-----------------------------	---

Lower Band Edge Plot on Channel 1312 (1712.4 MHz)

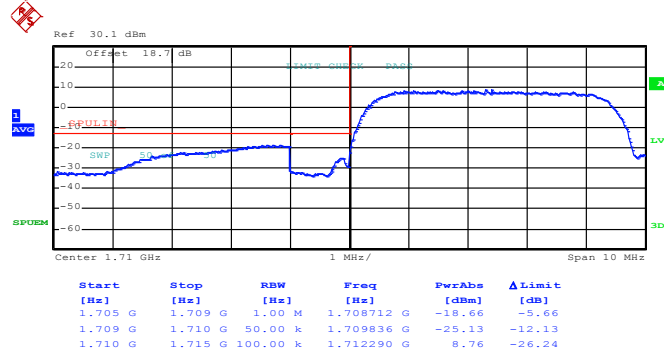

Date: 21.APR.2015 15:46:21

Higher Band Edge Plot on Channel 1513 (1752.6 MHz)

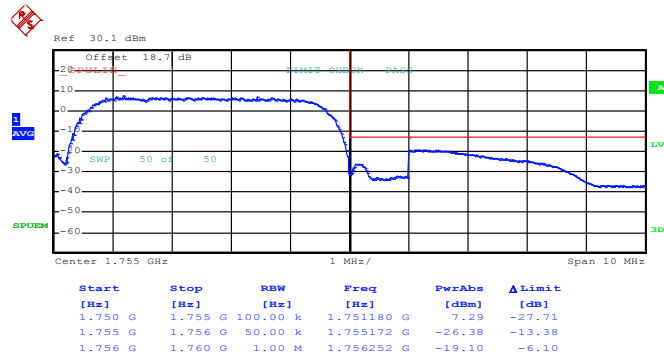

Date: 21.APR.2015 15:47:33



Band :	WCDMA Band II	Test Mode :	RMC 12.2Kbps Link (QPSK)
--------	---------------	-------------	--------------------------

Lower Band Edge Plot on Channel 9262 (1852.4 MHz)

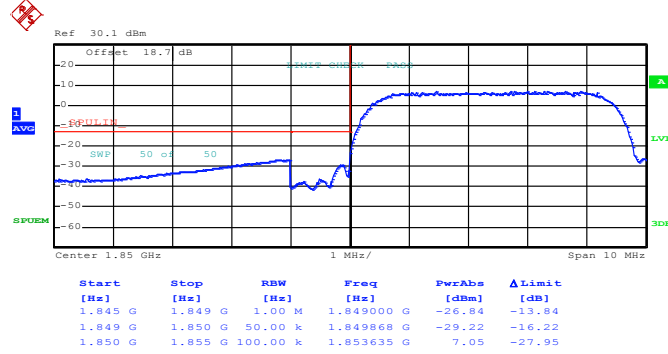

Date: 21.APR.2015 15:27:07

Higher Band Edge Plot on Channel 9538 (1907.6 MHz)

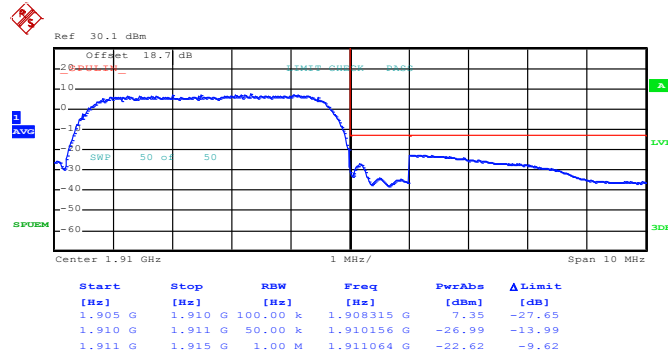

Date: 21.APR.2015 15:28:19

3.6 Conducted Spurious Emission Measurement

3.6.1 Description of Conducted Spurious Emission Measurement

The power of any emission outside of the authorized operating frequency ranges must be lower than the transmitter power (P) by a factor of at least $43 + 10 \log (P)$ dB.

It is measured by means of a calibrated spectrum analyzer and scanned from 30 MHz up to a frequency including its 10th harmonic.

3.6.2 Measuring Instruments

The measuring equipment is listed in the section 4 of this test report.

3.6.3 Test Procedures

1. The testing follows FCC KDB 971168 v02r02 Section 6.0.
2. The EUT was connected to the spectrum analyzer and system simulator via a power divider.
3. The RF output of EUT was connected to the spectrum analyzer by an RF cable and attenuator. The path loss was compensated to the results for each measurement.
4. The middle channel for the highest RF power within the transmitting frequency was measured.
5. The conducted spurious emission for the whole frequency range was taken.
6. The RF fundamental frequency should be excluded against the limit line in the operating frequency band.
7. The limit line is derived from $43 + 10\log(P)$ dB below the transmitter power P(Watts)
 $= P(W) - [43 + 10\log(P)]$ (dB)
 $= [30 + 10\log(P)]$ (dBm) - $[43 + 10\log(P)]$ (dB)
 $= -13\text{dBm}$.

3.6.4 Test Setup

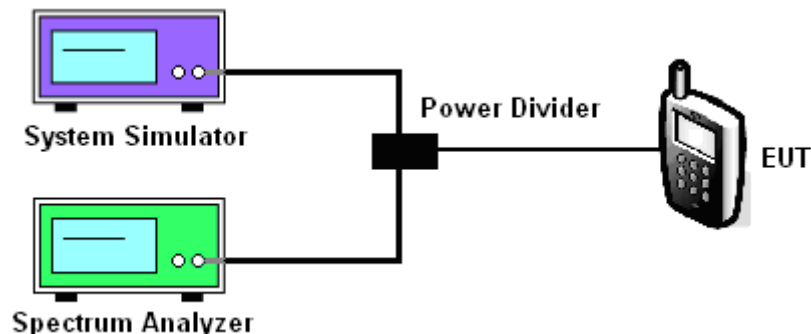



3.6.5 Test Result (Plots) of Conducted Spurious Emission

Band :	GSM850	Channel :	CH128
Test Mode :	GPRS class 8 Link (GMSK)	Frequency :	824.2 MHz

Conducted Spurious Emission Plot between 30MHz ~ 9GHz

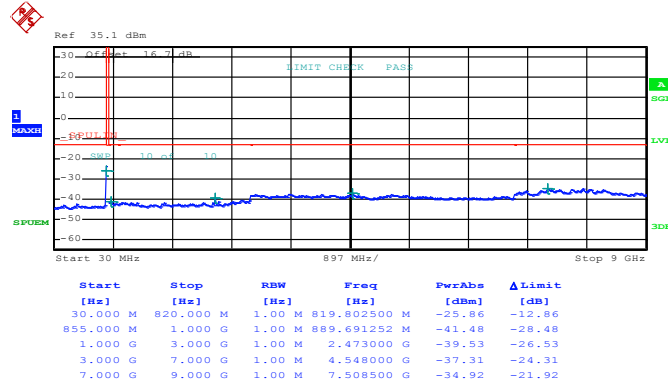

Date: 28.APR.2015 10:22:58



Band :	GSM850	Channel :	CH189
Test Mode :	GPRS class 8 Link (GMSK)	Frequency :	836.4 MHz

Conducted Spurious Emission Plot between 30MHz ~ 9GHz

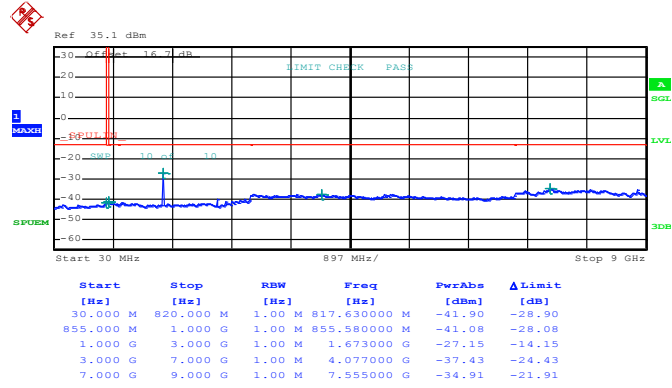

Date: 28.APR.2015 10:23:35



Band :	GSM850	Channel :	CH251
Test Mode :	GPRS class 8 Link (GMSK)	Frequency :	848.8 MHz

Conducted Spurious Emission Plot between 30MHz ~ 9GHz

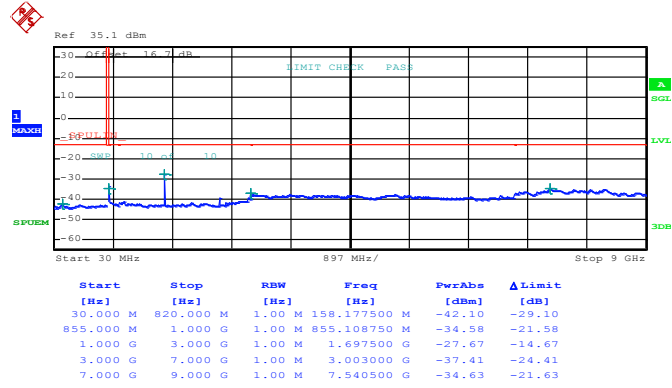

Date: 28.APR.2015 10:24:00



Band :	GSM850	Channel :	CH128
Test Mode :	EDGE class 8 Link (8PSK)	Frequency :	824.2 MHz

Conducted Spurious Emission Plot between 30MHz ~ 9GHz

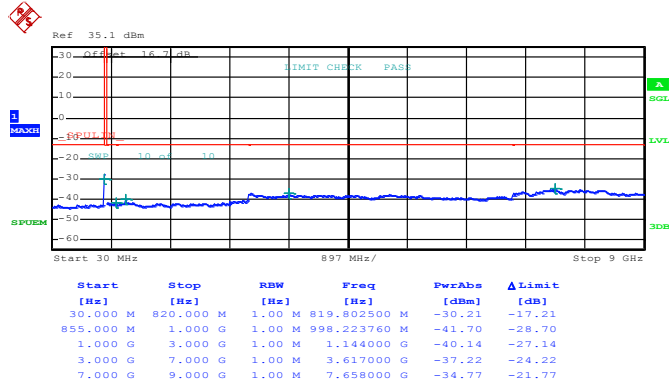

Date: 28.APR.2015 10:35:39



Band :	GSM850	Channel :	CH189
Test Mode :	EDGE class 8 Link (8PSK)	Frequency :	836.4 MHz

Conducted Spurious Emission Plot between 30MHz ~ 9GHz

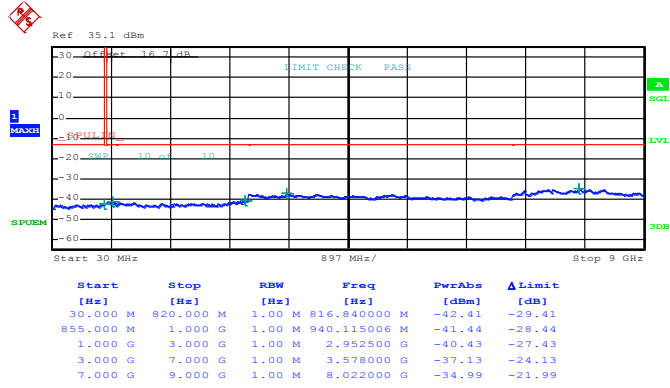

Date: 28.APR.2015 10:36:08



Band :	GSM850	Channel :	CH251
Test Mode :	EDGE class 8 Link (8PSK)	Frequency :	848.8 MHz

Conducted Spurious Emission Plot between 30MHz ~ 9GHz

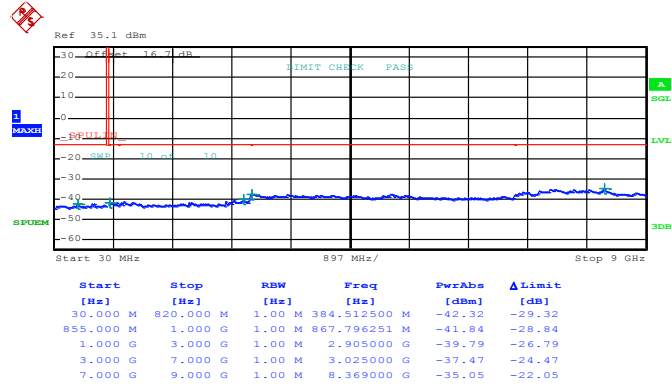

Date: 28.APR.2015 10:36:34



Band :	GSM1900	Channel :	CH512
Test Mode :	GPRS class 8 Link (GMSK)	Frequency :	1850.2 MHz

Conducted Spurious Emission Plot between 30MHz ~ 19.1GHz

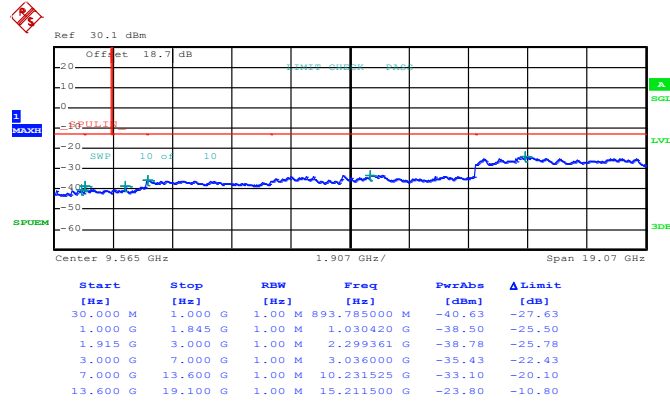

Date: 28.APR.2015 14:21:03



Band :	GSM1900	Channel :	CH661
Test Mode :	GPRS class 8 Link (GMSK)	Frequency :	1880.0 MHz

Conducted Spurious Emission Plot between 30MHz ~ 19.1GHz

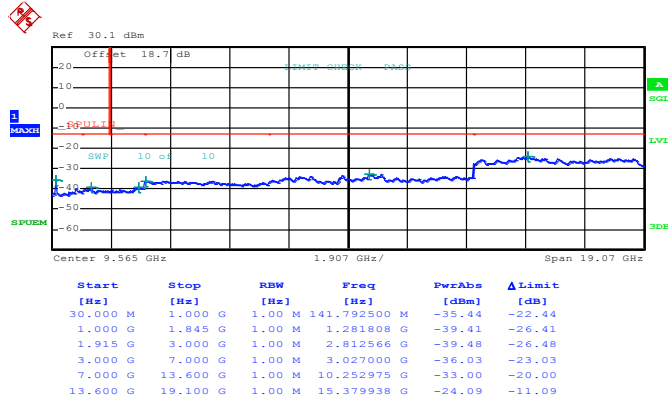

Date: 28.APR.2015 14:22:02



Band :	GSM1900	Channel :	CH810
Test Mode :	GPRS class 8 Link (GMSK)	Frequency :	1909.8 MHz

Conducted Spurious Emission Plot between 30MHz ~ 19.1GHz

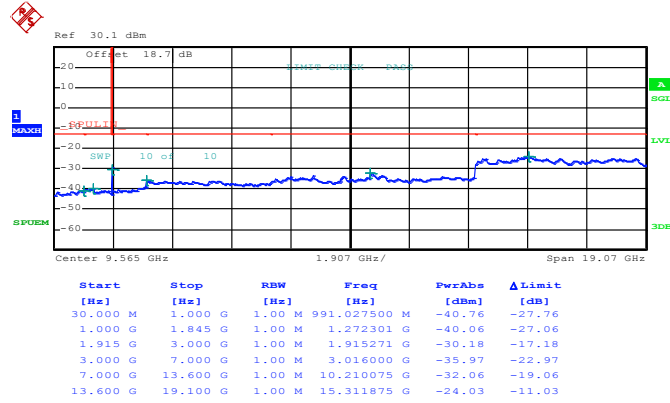

Date: 28.APR.2015 14:22:34



Band :	GSM1900	Channel :	CH512
Test Mode :	EDGE class 8 Link (8PSK)	Frequency :	1850.2 MHz

Conducted Spurious Emission Plot between 30MHz ~ 19.1GHz

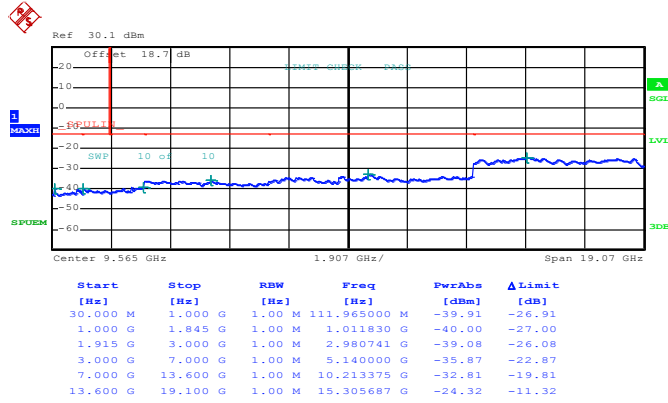

Date: 28.APR.2015 14:05:47



Band :	GSM1900	Channel :	CH661
Test Mode :	EDGE class 8 Link (8PSK)	Frequency :	1880.0 MHz

Conducted Spurious Emission Plot between 30MHz ~ 19.1GHz

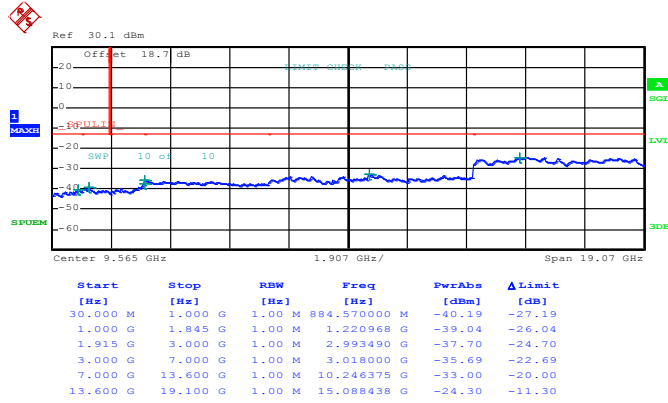

Date: 28.APR.2015 14:06:21



Band :	GSM1900	Channel :	CH810
Test Mode :	EDGE class 8 Link (8PSK)	Frequency :	1909.8 MHz

Conducted Spurious Emission Plot between 30MHz ~ 19.1GHz

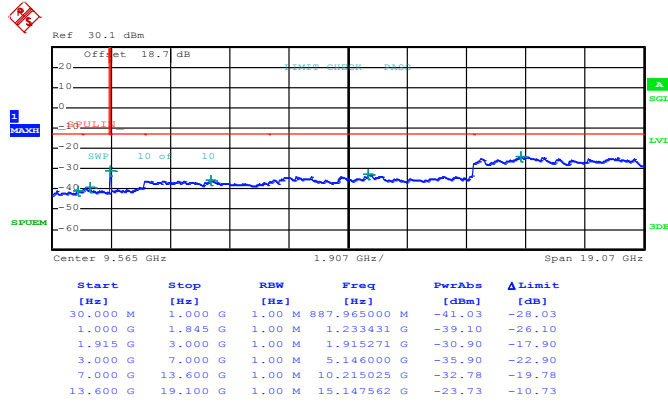

Date: 28.APR.2015 14:06:57



Band :	WCDMA Band V	Channel :	CH4132
Test Mode :	RMC 12.2Kbps Link (QPSK)	Frequency :	826.4 MHz

Conducted Spurious Emission Plot between 30MHz ~ 9GHz

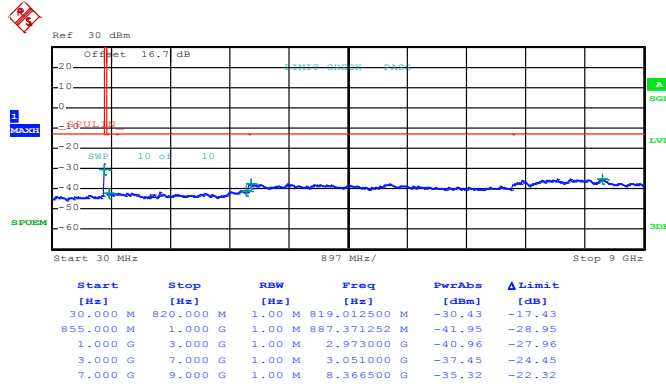

Date: 21.APR.2015 11:46:51



Band :	WCDMA Band V	Channel :	CH4182
Test Mode :	RMC 12.2Kbps Link (QPSK)	Frequency :	836.4 MHz

Conducted Spurious Emission Plot between 30MHz ~ 9GHz

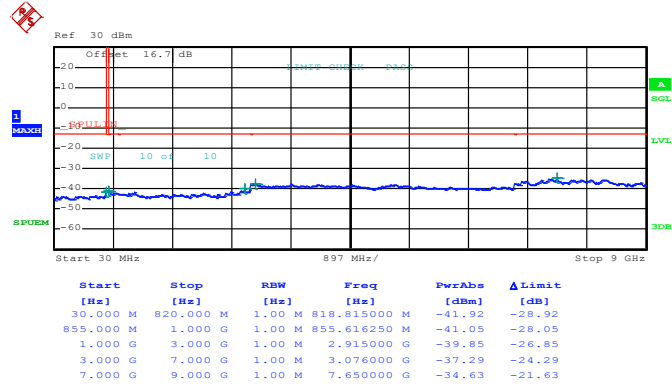

Date: 21.APR.2015 11:47:16



Band :	WCDMA Band V	Channel :	CH4233
Test Mode :	RMC 12.2Kbps Link (QPSK)	Frequency :	846.6 MHz

Conducted Spurious Emission Plot between 30MHz ~ 9GHz

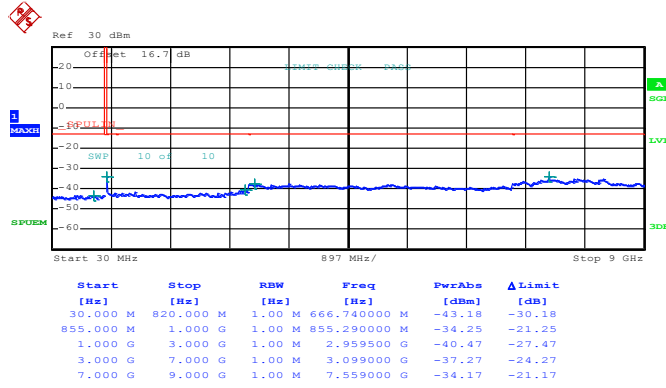

Date: 21.APR.2015 11:47:41



Band :	WCDMA Band IV	Channel :	CH1312
Test Mode :	RMC 12.2Kbps Link (QPSK)	Frequency :	1712.4 MHz

Conducted Spurious Emission Plot between 30MHz ~ 18GHz

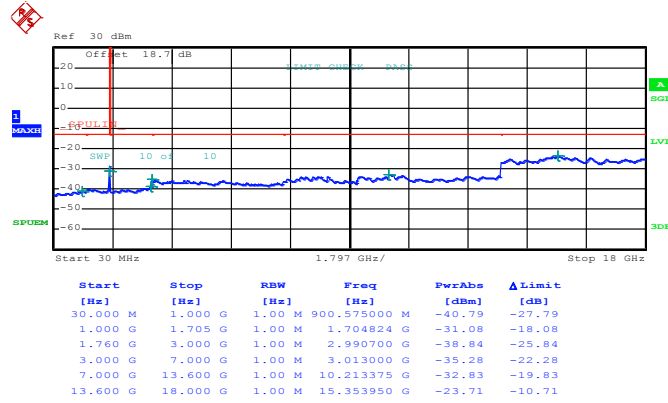

Date: 21.APR.2015 15:48:42



Band :	WCDMA Band IV	Channel :	CH1413
Test Mode :	RMC 12.2Kbps Link (QPSK)	Frequency :	1732.6 MHz

Conducted Spurious Emission Plot between 30MHz ~ 18GHz

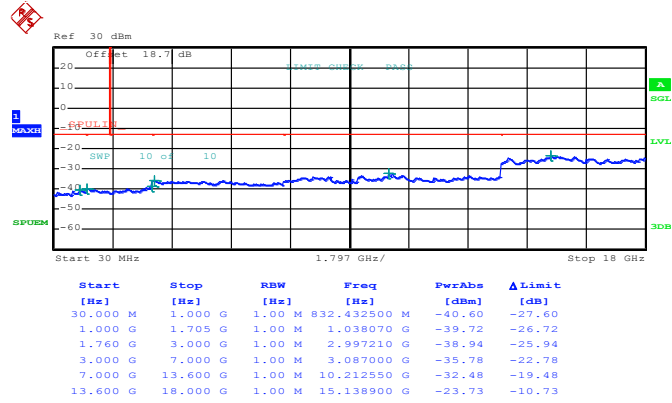

Date: 21.APR.2015 15:49:07



Band :	WCDMA Band IV	Channel :	CH1513
Test Mode :	RMC 12.2Kbps Link (QPSK)	Frequency :	1752.6 MHz

Conducted Spurious Emission Plot between 30MHz ~ 18GHz

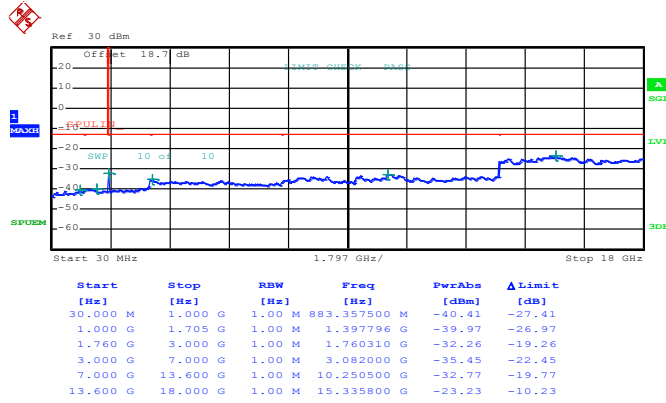

Date: 21.APR.2015 15:49:32



Band :	WCDMA Band II	Channel :	CH9262
Test Mode :	RMC 12.2Kbps Link (QPSK)	Frequency :	1852.4 MHz

Conducted Spurious Emission Plot between 30MHz ~ 19.1GHz

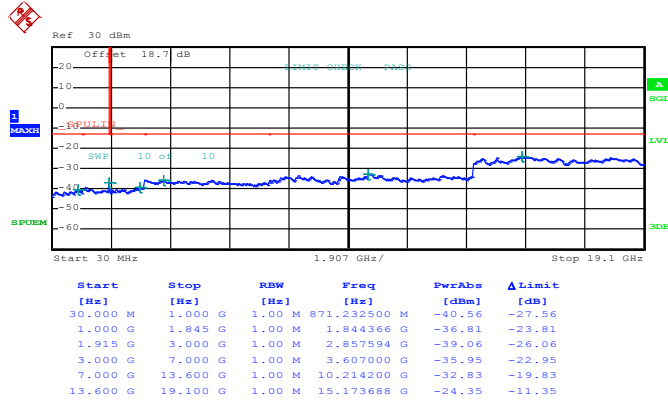

Date: 21.APR.2015 15:29:10



Band :	WCDMA Band II	Channel :	CH9400
Test Mode :	RMC 12.2Kbps Link (QPSK)	Frequency :	1880.0 MHz

Conducted Spurious Emission Plot between 30MHz ~ 19.1GHz

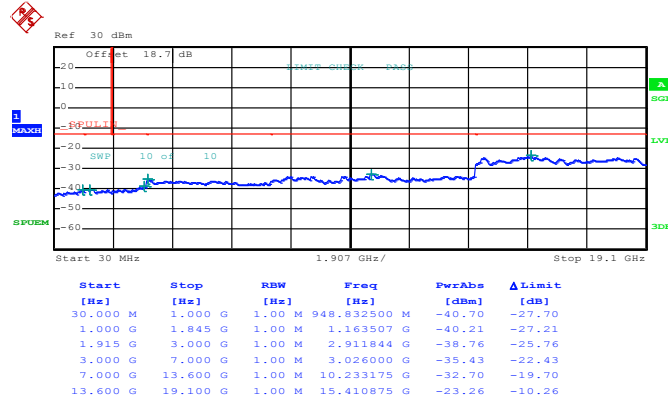

Date: 21.APR.2015 15:29:36



Band :	WCDMA Band II	Channel :	CH9538
Test Mode :	RMC 12.2Kbps Link (QPSK)	Frequency :	1907.6 MHz

Conducted Spurious Emission Plot between 30MHz ~ 19.1GHz

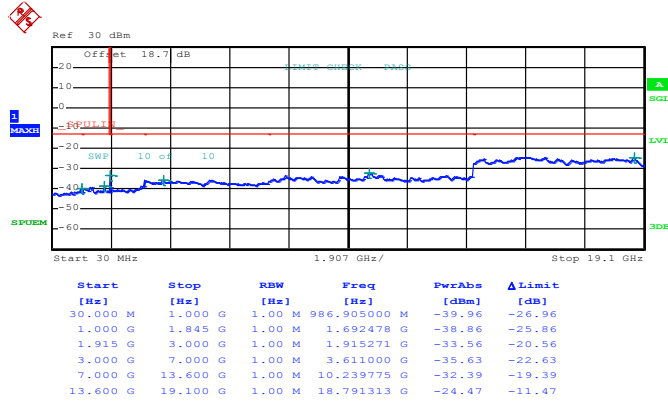

Date: 21.APR.2015 15:30:01



3.7 Field Strength of Spurious Radiation Measurement

3.7.1 Description of Field Strength of Spurious Radiated Measurement

The power of any emission outside of the authorized operating frequency ranges must be attenuated below the transmitter power (P) by a factor of at least $43 + 10 \log (P)$ dB. The spectrum is scanned from 30 MHz up to a frequency including its 10th harmonic.

3.7.2 Measuring Instruments

The measuring equipment is listed in the section 4 of this test report.

3.7.3 Test Procedures

1. The testing follows FCC KDB 971168 v02r02 Section 5.8 and ANSI / TIA-603-C-2004 Section 2.2.12.
2. The EUT was placed on a rotatable wooden table 0.8 meters above the ground.
3. The EUT was set 3 meters from the receiving antenna, which was mounted on the antenna tower.
4. The table was rotated 360 degrees to determine the position of the highest spurious emission.
5. The height of the receiving antenna is varied between one meter and four meters to search for the maximum spurious emission for both horizontal and vertical polarizations.
6. Make the measurement with the spectrum analyzer's RBW = 1MHz, VBW = 3MHz, taking record of maximum spurious emission.
7. A horn antenna was substituted in place of the EUT and was driven by a signal generator.
8. Tune the output power of signal generator to the same emission level with EUT maximum spurious emission.
9. Taking the record of output power at antenna port.
10. Repeat step 7 to step 8 for another polarization.
11. $EIRP \text{ (dBm)} = S.G. \text{ Power} - Tx \text{ Cable Loss} + Tx \text{ Antenna Gain}$
12. $ERP \text{ (dBm)} = EIRP - 2.15$
13. The RF fundamental frequency should be excluded against the limit line in the operating frequency band.
14. The limit line is derived from $43 + 10\log(P)$ dB below the transmitter power P(Watts)
 $= P(W) - [43 + 10\log(P)] \text{ (dB)}$
 $= [30 + 10\log(P)] \text{ (dBm)} - [43 + 10\log(P)] \text{ (dB)}$
 $= -13dBm.$

3.7.4 Test Setup

For radiated emissions from 30MHz to 1GHz

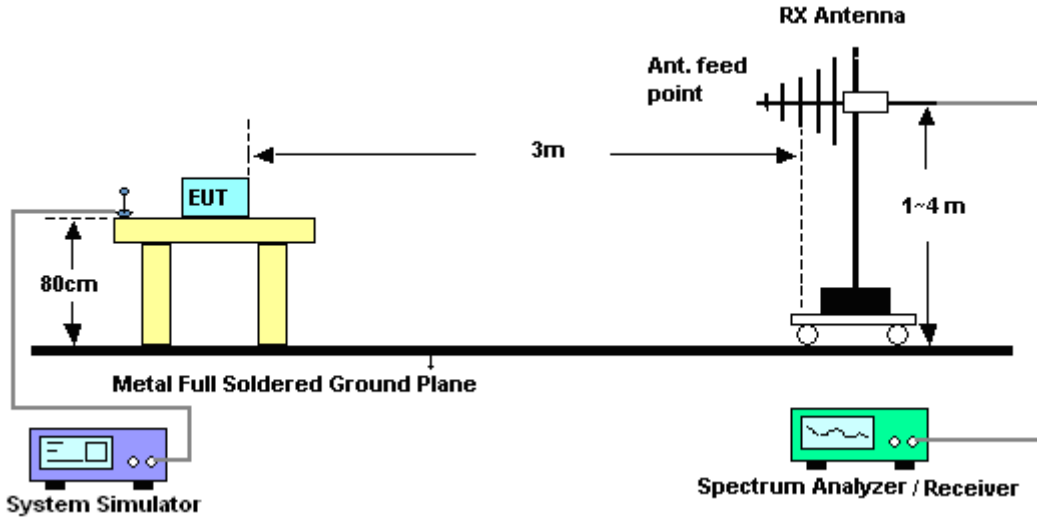

For radiated emissions above 1GHz

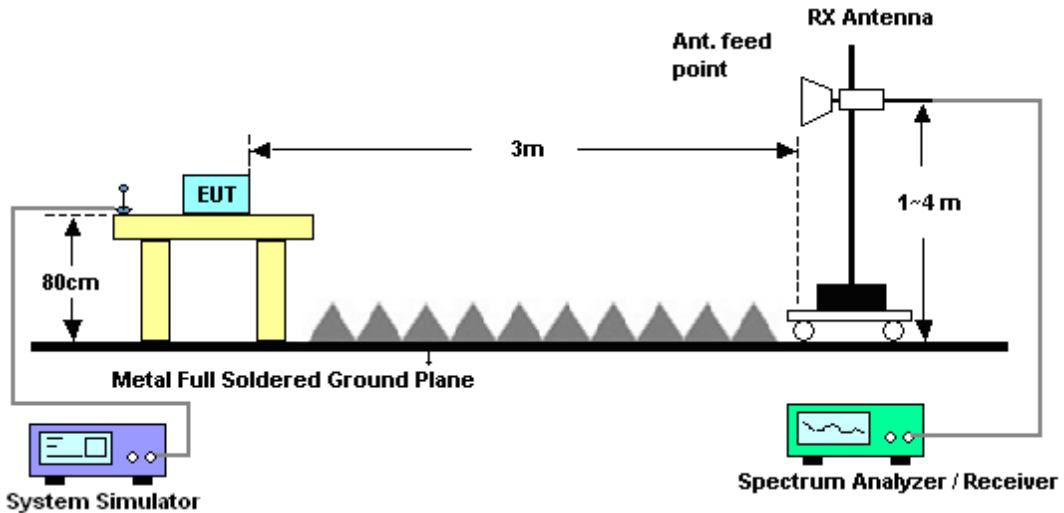



3.7.5 Test Result of Field Strength of Spurious Radiated

<Low Channel>

Band :	GSM850						Temperature :	21~24°C		
Test Mode :	GPRS class 8 Link (GMSK) for Adapter 1						Relative Humidity :	46~55%		
Test Engineer :	Nick Yu, James Chiu and Ken Wu						Polarization :	Horizontal		
Remark :	Spurious emissions within 30-1000MHz were found more than 20dB below limit line.									
Frequency (MHz)	ERP (dBm)	Limit (dBm)	Over Limit (dB)	SPA Reading (dBm)	S.G. Power (dBm)	TX Cable loss (dB)	TX Antenna Gain (dBi)	Polarization (H/V)	Result	
1648	-64.05	-13	-51.05	-75.06	-65.81	0.98	4.89	H	Pass	
2472	-53.23	-13	-40.23	-69.56	-55.11	1.28	5.32	H	Pass	
3296	-59.41	-13	-46.41	-76.74	-62.82	1.54	7.10	H	Pass	

Band :	GSM850						Temperature :	21~24°C		
Test Mode :	GPRS class 8 Link (GMSK) for Adapter 1						Relative Humidity :	46~55%		
Test Engineer :	Nick Yu, James Chiu and Ken Wu						Polarization :	Vertical		
Remark :	Spurious emissions within 30-1000MHz were found more than 20dB below limit line.									
Frequency (MHz)	ERP (dBm)	Limit (dBm)	Over Limit (dB)	SPA Reading (dBm)	S.G. Power (dBm)	TX Cable loss (dB)	TX Antenna Gain (dBi)	Polarization (H/V)	Result	
1648	-61.46	-13	-48.46	-73.3	-63.22	0.98	4.89	V	Pass	
2472	-58.43	-13	-45.43	-76.1	-60.31	1.28	5.32	V	Pass	
3296	-57.73	-13	-44.73	-76.76	-61.14	1.54	7.10	V	Pass	



<Middle Channel>

Band :	GSM850		Temperature :	21~24°C					
Test Mode :	GPRS class 8 Link (GMSK) for Adapter 1		Relative Humidity :	46~55%					
Test Engineer :	Nick Yu, James Chiu and Ken Wu		Polarization :	Horizontal					
Remark :	Spurious emissions within 30-1000MHz were found more than 20dB below limit line.								
Frequency (MHz)	ERP (dBm)	Limit (dBm)	Over Limit (dB)	SPA Reading (dBm)	S.G. Power (dBm)	TX Cable loss (dB)	TX Antenna Gain (dBi)	Polarization (H/V)	Result
1672	-63.86	-13	-50.86	-75.08	-65.54	0.99	4.82	H	Pass
2512	-42.98	-13	-29.98	-59.59	-44.95	1.29	5.41	H	Pass
3345	-59.41	-13	-46.41	-76.66	-63.02	1.56	7.32	H	Pass

Band :	GSM850		Temperature :	21~24°C					
Test Mode :	GPRS class 8 Link (GMSK) for Adapter 1		Relative Humidity :	46~55%					
Test Engineer :	Nick Yu, James Chiu and Ken Wu		Polarization :	Vertical					
Remark :	Spurious emissions within 30-1000MHz were found more than 20dB below limit line.								
Frequency (MHz)	ERP (dBm)	Limit (dBm)	Over Limit (dB)	SPA Reading (dBm)	S.G. Power (dBm)	TX Cable loss (dB)	TX Antenna Gain (dBi)	Polarization (H/V)	Result
1672	-63.34	-13	-50.34	-75.06	-65.02	0.99	4.82	V	Pass
2512	-52.84	-13	-39.84	-70.86	-54.81	1.29	5.41	V	Pass
3345	-57.61	-13	-44.61	-76.55	-61.22	1.56	7.32	V	Pass



<High Channel>

Band :	GSM850						Temperature :	21~24°C		
Test Mode :	GPRS class 8 Link (GMSK) for Adapter 1						Relative Humidity :	46~55%		
Test Engineer :	Nick Yu, James Chiu and Ken Wu						Polarization :	Horizontal		
Remark :	Spurious emissions within 30-1000MHz were found more than 20dB below limit line.									
Frequency (MHz)	ERP (dBm)	Limit (dBm)	Over Limit (dB)	SPA Reading (dBm)	S.G. Power (dBm)	TX Cable loss (dB)	TX Antenna Gain (dBi)	Polarization (H/V)	Result	
1696	-63.49	-13	-50.49	-75.1	-65.09	1.00	4.75	H	Pass	
2544	-54.33	-13	-41.33	-70.93	-56.31	1.30	5.44	H	Pass	
3392	-59.31	-13	-46.31	-76.89	-63.11	1.57	7.52	H	Pass	

Band :	GSM850						Temperature :	21~24°C		
Test Mode :	GPRS class 8 Link (GMSK) for Adapter 1						Relative Humidity :	46~55%		
Test Engineer :	Nick Yu, James Chiu and Ken Wu						Polarization :	Vertical		
Remark :	Spurious emissions within 30-1000MHz were found more than 20dB below limit line.									
Frequency (MHz)	ERP (dBm)	Limit (dBm)	Over Limit (dB)	SPA Reading (dBm)	S.G. Power (dBm)	TX Cable loss (dB)	TX Antenna Gain (dBi)	Polarization (H/V)	Result	
1696	-62.73	-13	-49.73	-75.14	-64.33	1.00	4.75	V	Pass	
2544	-57.73	-13	-44.73	-75.94	-59.71	1.30	5.44	V	Pass	
3392	-58.01	-13	-45.01	-76.97	-61.81	1.57	7.52	V	Pass	



<Low Channel>

Band :	GSM850		Temperature :	21~24°C					
Test Mode :	GPRS class 8 Link (GMSK) for Adapter 2		Relative Humidity :	46~55%					
Test Engineer :	Nick Yu, James Chiu and Ken Wu		Polarization :	Horizontal					
Remark :	Spurious emissions within 30-1000MHz were found more than 20dB below limit line.								
Frequency (MHz)	ERP (dBm)	Limit (dBm)	Over Limit (dB)	SPA Reading (dBm)	S.G. Power (dBm)	TX Cable loss (dB)	TX Antenna Gain (dBi)	Polarization (H/V)	Result
1648	-39.22	-13	-26.22	-49.94	-40.98	0.98	4.89	H	Pass
2472	-44.34	-13	-31.34	-60.27	-46.22	1.28	5.32	H	Pass
3296	-59.90	-13	-46.90	-76.85	-63.31	1.54	7.10	H	Pass

Band :	GSM850		Temperature :	21~24°C					
Test Mode :	GPRS class 8 Link (GMSK) for Adapter 2		Relative Humidity :	46~55%					
Test Engineer :	Nick Yu, James Chiu and Ken Wu		Polarization :	Vertical					
Remark :	Spurious emissions within 30-1000MHz were found more than 20dB below limit line.								
Frequency (MHz)	ERP (dBm)	Limit (dBm)	Over Limit (dB)	SPA Reading (dBm)	S.G. Power (dBm)	TX Cable loss (dB)	TX Antenna Gain (dBi)	Polarization (H/V)	Result
1648	-38.89	-13	-25.89	-50.26	-40.65	0.98	4.89	V	Pass
2472	-50.87	-13	-37.87	-68.44	-52.75	1.28	5.32	V	Pass
3296	-57.36	-13	-44.36	-75.88	-60.77	1.54	7.10	V	Pass



<Middle Channel>

Band :	GSM850		Temperature :	21~24°C					
Test Mode :	GPRS class 8 Link (GMSK) for Adapter 2		Relative Humidity :	46~55%					
Test Engineer :	Nick Yu, James Chiu and Ken Wu		Polarization :	Horizontal					
Remark :	Spurious emissions within 30-1000MHz were found more than 20dB below limit line.								
Frequency (MHz)	ERP (dBm)	Limit (dBm)	Over Limit (dB)	SPA Reading (dBm)	S.G. Power (dBm)	TX Cable loss (dB)	TX Antenna Gain (dBi)	Polarization (H/V)	Result
1672	-40.70	-13	-27.70	-51.68	-42.38	0.99	4.82	H	Pass
2512	-45.58	-13	-32.58	-61.75	-47.55	1.29	5.41	H	Pass
3344	-60.00	-13	-47.00	-76.92	-63.61	1.56	7.31	H	Pass

Band :	GSM850		Temperature :	21~24°C					
Test Mode :	GPRS class 8 Link (GMSK) for Adapter 2		Relative Humidity :	46~55%					
Test Engineer :	Nick Yu, James Chiu and Ken Wu		Polarization :	Vertical					
Remark :	Spurious emissions within 30-1000MHz were found more than 20dB below limit line.								
Frequency (MHz)	ERP (dBm)	Limit (dBm)	Over Limit (dB)	SPA Reading (dBm)	S.G. Power (dBm)	TX Cable loss (dB)	TX Antenna Gain (dBi)	Polarization (H/V)	Result
1672	-40.00	-13	-27.00	-51.26	-41.68	0.99	4.82	V	Pass
2512	-50.66	-13	-37.66	-68.06	-52.63	1.29	5.41	V	Pass
3344	-58.34	-13	-45.34	-77.05	-61.95	1.56	7.31	V	Pass



<High Channel>

Band :	GSM850		Temperature :	21~24°C					
Test Mode :	GPRS class 8 Link (GMSK) for Adapter 2		Relative Humidity :	46~55%					
Test Engineer :	Nick Yu, James Chiu and Ken Wu		Polarization :	Horizontal					
Remark :	Spurious emissions within 30-1000MHz were found more than 20dB below limit line.								
Frequency (MHz)	ERP (dBm)	Limit (dBm)	Over Limit (dB)	SPA Reading (dBm)	S.G. Power (dBm)	TX Cable loss (dB)	TX Antenna Gain (dBi)	Polarization (H/V)	Result
1696	-39.83	-13	-26.83	-51.22	-41.43	1.00	4.75	H	Pass
2544	-50.91	-13	-37.91	-66.76	-52.89	1.30	5.44	H	Pass
3392	-60.03	-13	-47.03	-77.12	-63.83	1.57	7.52	H	Pass

Band :	GSM850		Temperature :	21~24°C					
Test Mode :	GPRS class 8 Link (GMSK) for Adapter 2		Relative Humidity :	46~55%					
Test Engineer :	Nick Yu, James Chiu and Ken Wu		Polarization :	Vertical					
Remark :	Spurious emissions within 30-1000MHz were found more than 20dB below limit line.								
Frequency (MHz)	ERP (dBm)	Limit (dBm)	Over Limit (dB)	SPA Reading (dBm)	S.G. Power (dBm)	TX Cable loss (dB)	TX Antenna Gain (dBi)	Polarization (H/V)	Result
1696	-38.39	-13	-25.39	-50.3	-39.99	1.00	4.75	V	Pass
2544	-49.75	-13	-36.75	-67.66	-51.73	1.30	5.44	V	Pass
3392	-58.64	-13	-45.64	-76.96	-62.44	1.57	7.52	V	Pass



<Low Channel>

Band :	GSM850		Temperature :	21~24°C					
Test Mode :	GPRS class 8 Link (GMSK) for Adapter 3		Relative Humidity :	46~55%					
Test Engineer :	Nick Yu, James Chiu and Ken Wu		Polarization :	Horizontal					
Remark :	Spurious emissions within 30-1000MHz were found more than 20dB below limit line.								
Frequency (MHz)	ERP (dBm)	Limit (dBm)	Over Limit (dB)	SPA Reading (dBm)	S.G. Power (dBm)	TX Cable loss (dB)	TX Antenna Gain (dBi)	Polarization (H/V)	Result
1648	-45.45	-13	-32.45	-56.06	-47.21	0.98	4.89	H	Pass
2472	-58.34	-13	-45.34	-74.26	-60.22	1.28	5.32	H	Pass
3296	-60.20	-13	-47.20	-77.16	-63.61	1.54	7.10	H	Pass

Band :	GSM850		Temperature :	21~24°C					
Test Mode :	GPRS class 8 Link (GMSK) for Adapter 3		Relative Humidity :	46~55%					
Test Engineer :	Nick Yu, James Chiu and Ken Wu		Polarization :	Vertical					
Remark :	Spurious emissions within 30-1000MHz were found more than 20dB below limit line.								
Frequency (MHz)	ERP (dBm)	Limit (dBm)	Over Limit (dB)	SPA Reading (dBm)	S.G. Power (dBm)	TX Cable loss (dB)	TX Antenna Gain (dBi)	Polarization (H/V)	Result
1648	-46.96	-13	-33.96	-58.18	-48.72	0.98	4.89	V	Pass
2472	-53.95	-13	-40.95	-72	-55.83	1.28	5.32	V	Pass
3296	-58.36	-13	-45.36	-76.88	-61.77	1.54	7.10	V	Pass



<Middle Channel>

Band :	GSM850		Temperature :	21~24°C					
Test Mode :	GPRS class 8 Link (GMSK) for Adapter 3		Relative Humidity :	46~55%					
Test Engineer :	Nick Yu, James Chiu and Ken Wu		Polarization :	Horizontal					
Remark :	Spurious emissions within 30-1000MHz were found more than 20dB below limit line.								
Frequency (MHz)	ERP (dBm)	Limit (dBm)	Over Limit (dB)	SPA Reading (dBm)	S.G. Power (dBm)	TX Cable loss (dB)	TX Antenna Gain (dBi)	Polarization (H/V)	Result
1672	-46.03	-13	-33.03	-56.71	-47.71	0.99	4.82	H	Pass
2512	-50.21	-13	-37.21	-65.98	-52.18	1.29	5.41	H	Pass
3344	-60.01	-13	-47.01	-76.87	-63.62	1.56	7.31	H	Pass

Band :	GSM850		Temperature :	21~24°C					
Test Mode :	GPRS class 8 Link (GMSK) for Adapter 3		Relative Humidity :	46~55%					
Test Engineer :	Nick Yu, James Chiu and Ken Wu		Polarization :	Vertical					
Remark :	Spurious emissions within 30-1000MHz were found more than 20dB below limit line.								
Frequency (MHz)	ERP (dBm)	Limit (dBm)	Over Limit (dB)	SPA Reading (dBm)	S.G. Power (dBm)	TX Cable loss (dB)	TX Antenna Gain (dBi)	Polarization (H/V)	Result
1672	-47.07	-13	-34.07	-58.49	-48.75	0.99	4.82	V	Pass
2512	-54.65	-13	-41.65	-72.31	-56.62	1.29	5.41	V	Pass
3344	-58.37	-13	-45.37	-76.81	-61.98	1.56	7.31	V	Pass



<High Channel>

Band :	GSM850		Temperature :	21~24°C					
Test Mode :	GPRS class 8 Link (GMSK) for Adapter 3		Relative Humidity :	46~55%					
Test Engineer :	Nick Yu, James Chiu and Ken Wu		Polarization :	Horizontal					
Remark :	Spurious emissions within 30-1000MHz were found more than 20dB below limit line.								
Frequency (MHz)	ERP (dBm)	Limit (dBm)	Over Limit (dB)	SPA Reading (dBm)	S.G. Power (dBm)	TX Cable loss (dB)	TX Antenna Gain (dBi)	Polarization (H/V)	Result
1696	-39.25	-13	-26.25	-50.34	-40.85	1.00	4.75	H	Pass
2544	-54.36	-13	-41.36	-70.42	-56.34	1.30	5.44	H	Pass
3392	-59.82	-13	-46.82	-77	-63.62	1.57	7.52	H	Pass

Band :	GSM850		Temperature :	21~24°C					
Test Mode :	GPRS class 8 Link (GMSK) for Adapter 3		Relative Humidity :	46~55%					
Test Engineer :	Nick Yu, James Chiu and Ken Wu		Polarization :	Vertical					
Remark :	Spurious emissions within 30-1000MHz were found more than 20dB below limit line.								
Frequency (MHz)	ERP (dBm)	Limit (dBm)	Over Limit (dB)	SPA Reading (dBm)	S.G. Power (dBm)	TX Cable loss (dB)	TX Antenna Gain (dBi)	Polarization (H/V)	Result
1696	-42.01	-13	-29.01	-53.6	-43.61	1.00	4.75	V	Pass
2544	-53.30	-13	-40.30	-70.97	-55.28	1.30	5.44	V	Pass
3392	-58.02	-13	-45.02	-76.44	-61.82	1.57	7.52	V	Pass



<Low Channel>

Band :	GSM850		Temperature :	21~24°C					
Test Mode :	EDGE class 8 Link (8PSK) for Adapter 1		Relative Humidity :	46~55%					
Test Engineer :	Nick Yu, James Chiu and Ken Wu		Polarization :	Horizontal					
Remark :	Spurious emissions within 30-1000MHz were found more than 20dB below limit line.								
Frequency (MHz)	ERP (dBm)	Limit (dBm)	Over Limit (dB)	SPA Reading (dBm)	S.G. Power (dBm)	TX Cable loss (dB)	TX Antenna Gain (dBi)	Polarization (H/V)	Result
1648	-63.93	-13	-50.93	-74.87	-65.69	0.98	4.89	H	Pass
2472	-59.48	-13	-46.48	-75.77	-61.36	1.28	5.32	H	Pass
3296	-59.68	-13	-46.68	-77.04	-63.09	1.54	7.10	H	Pass

Band :	GSM850		Temperature :	21~24°C					
Test Mode :	EDGE class 8 Link (8PSK) for Adapter 1		Relative Humidity :	46~55%					
Test Engineer :	Nick Yu, James Chiu and Ken Wu		Polarization :	Vertical					
Remark :	Spurious emissions within 30-1000MHz were found more than 20dB below limit line.								
Frequency (MHz)	ERP (dBm)	Limit (dBm)	Over Limit (dB)	SPA Reading (dBm)	S.G. Power (dBm)	TX Cable loss (dB)	TX Antenna Gain (dBi)	Polarization (H/V)	Result
1648	-62.65	-13	-49.65	-74.4	-64.41	0.98	4.89	V	Pass
2472	-58.03	-13	-45.03	-75.74	-59.91	1.28	5.32	V	Pass
3296	-57.92	-13	-44.92	-76.98	-61.33	1.54	7.10	V	Pass



<Middle Channel>

Band :	GSM850		Temperature :	21~24°C					
Test Mode :	EDGE class 8 Link (8PSK) for Adapter 1		Relative Humidity :	46~55%					
Test Engineer :	Nick Yu, James Chiu and Ken Wu		Polarization :	Horizontal					
Remark :	Spurious emissions within 30-1000MHz were found more than 20dB below limit line.								
Frequency (MHz)	ERP (dBm)	Limit (dBm)	Over Limit (dB)	SPA Reading (dBm)	S.G. Power (dBm)	TX Cable loss (dB)	TX Antenna Gain (dBi)	Polarization (H/V)	Result
1672	-63.51	-13	-50.51	-74.71	-65.19	0.99	4.82	H	Pass
2512	-59.54	-13	-46.54	-76.11	-61.51	1.29	5.41	H	Pass
3344	-59.31	-13	-46.31	-76.66	-62.92	1.56	7.31	H	Pass

Band :	GSM850		Temperature :	21~24°C					
Test Mode :	EDGE class 8 Link (8PSK) for Adapter 1		Relative Humidity :	46~55%					
Test Engineer :	Nick Yu, James Chiu and Ken Wu		Polarization :	Vertical					
Remark :	Spurious emissions within 30-1000MHz were found more than 20dB below limit line.								
Frequency (MHz)	ERP (dBm)	Limit (dBm)	Over Limit (dB)	SPA Reading (dBm)	S.G. Power (dBm)	TX Cable loss (dB)	TX Antenna Gain (dBi)	Polarization (H/V)	Result
1672	-63.43	-13	-50.43	-75.34	-65.11	0.99	4.82	V	Pass
2512	-58.12	-13	-45.12	-75.99	-60.09	1.29	5.41	V	Pass
3344	-57.96	-13	-44.96	-76.86	-61.57	1.56	7.31	V	Pass



<High Channel>

Band :	GSM850		Temperature :	21~24°C					
Test Mode :	EDGE class 8 Link (8PSK) for Adapter 1		Relative Humidity :	46~55%					
Test Engineer :	Nick Yu, James Chiu and Ken Wu		Polarization :	Horizontal					
Remark :	Spurious emissions within 30-1000MHz were found more than 20dB below limit line.								
Frequency (MHz)	ERP (dBm)	Limit (dBm)	Over Limit (dB)	SPA Reading (dBm)	S.G. Power (dBm)	TX Cable loss (dB)	TX Antenna Gain (dBi)	Polarization (H/V)	Result
1696	-63.81	-13	-50.81	-75.51	-65.41	1.00	4.75	H	Pass
2544	-59.61	-13	-46.61	-76.23	-61.59	1.30	5.44	H	Pass
3392	-59.42	-13	-46.42	-77.04	-63.22	1.57	7.52	H	Pass

Band :	GSM850		Temperature :	21~24°C					
Test Mode :	EDGE class 8 Link (8PSK) for Adapter 1		Relative Humidity :	46~55%					
Test Engineer :	Nick Yu, James Chiu and Ken Wu		Polarization :	Vertical					
Remark :	Spurious emissions within 30-1000MHz were found more than 20dB below limit line.								
Frequency (MHz)	ERP (dBm)	Limit (dBm)	Over Limit (dB)	SPA Reading (dBm)	S.G. Power (dBm)	TX Cable loss (dB)	TX Antenna Gain (dBi)	Polarization (H/V)	Result
1696	-62.84	-13	-49.84	-75.26	-64.44	1.00	4.75	V	Pass
2544	-58.18	-13	-45.18	-76.25	-62.31	1.30	5.44	V	Pass
3392	-57.93	-13	-44.93	-76.78	-63.88	1.57	7.52	V	Pass



<Low Channel>

Band :	GSM1900		Temperature :	21~24°C					
Test Mode :	GPRS class 8 Link (GMSK) for Adapter 1		Relative Humidity :	46~55%					
Test Engineer :	Nick Yu, James Chiu and Ken Wu		Polarization :	Horizontal					
Remark :	Spurious emissions within 30-1000MHz were found more than 20dB below limit line.								
Frequency (MHz)	EIRP (dBm)	Limit (dBm)	Over Limit (dB)	SPA Reading (dBm)	S.G. Power (dBm)	TX Cable loss (dB)	TX Antenna Gain (dBi)	Polarization (H/V)	Result
3700	-58.24	-13	-45.24	-77.42	-64.81	1.67	8.24	H	Pass
5548	-53.75	-13	-40.75	-78.46	-60.82	2.65	9.72	H	Pass
7400	-52.38	-13	-39.38	-78.78	-61.52	2.46	11.60	H	Pass

Band :	GSM1900		Temperature :	21~24°C					
Test Mode :	GPRS class 8 Link (GMSK) for Adapter 1		Relative Humidity :	46~55%					
Test Engineer :	Nick Yu, James Chiu and Ken Wu		Polarization :	Vertical					
Remark :	Spurious emissions within 30-1000MHz were found more than 20dB below limit line.								
Frequency (MHz)	EIRP (dBm)	Limit (dBm)	Over Limit (dB)	SPA Reading (dBm)	S.G. Power (dBm)	TX Cable loss (dB)	TX Antenna Gain (dBi)	Polarization (H/V)	Result
3700	-57.54	-13	-44.54	-77.72	-64.11	1.67	8.24	V	Pass
5548	-49.02	-13	-36.02	-74.69	-56.09	2.65	9.72	V	Pass
7400	-50.93	-13	-37.93	-78.89	-60.07	2.46	11.60	V	Pass



<Middle Channel>

Band :	GSM1900		Temperature :	21~24°C					
Test Mode :	GPRS class 8 Link (GMSK) for Adapter 1		Relative Humidity :	46~55%					
Test Engineer :	Nick Yu, James Chiu and Ken Wu		Polarization :	Horizontal					
Remark :	Spurious emissions within 30-1000MHz were found more than 20dB below limit line.								
Frequency (MHz)	EIRP (dBm)	Limit (dBm)	Over Limit (dB)	SPA Reading (dBm)	S.G. Power (dBm)	TX Cable loss (dB)	TX Antenna Gain (dBi)	Polarization (H/V)	Result
3756	-57.57	-13	-44.57	-76.96	-64.19	1.68	8.31	H	Pass
5639	-53.06	-13	-40.06	-77.68	-60.11	2.71	9.76	H	Pass
7520	-51.69	-13	-38.69	-78.72	-61.08	2.42	11.81	H	Pass

Band :	GSM1900		Temperature :	21~24°C					
Test Mode :	GPRS class 8 Link (GMSK) for Adapter 1		Relative Humidity :	46~55%					
Test Engineer :	Nick Yu, James Chiu and Ken Wu		Polarization :	Vertical					
Remark :	Spurious emissions within 30-1000MHz were found more than 20dB below limit line.								
Frequency (MHz)	EIRP (dBm)	Limit (dBm)	Over Limit (dB)	SPA Reading (dBm)	S.G. Power (dBm)	TX Cable loss (dB)	TX Antenna Gain (dBi)	Polarization (H/V)	Result
3756	-57.29	-13	-44.29	-77.35	-63.91	1.68	8.31	V	Pass
5639	-45.76	-13	-32.76	-71.46	-52.81	2.71	9.76	V	Pass
7520	-50.04	-13	-37.04	-78.81	-59.43	2.42	11.81	V	Pass



<High Channel>

Band :	GSM1900						Temperature :	21~24°C	
Test Mode :	GPRS class 8 Link (GMSK) for Adapter 1						Relative Humidity :	46~55%	
Test Engineer :	Nick Yu, James Chiu and Ken Wu						Polarization :	Horizontal	
Remark :	Spurious emissions within 30-1000MHz were found more than 20dB below limit line.								
Frequency (MHz)	EIRP (dBm)	Limit (dBm)	Over Limit (dB)	SPA Reading (dBm)	S.G. Power (dBm)	TX Cable loss (dB)	TX Antenna Gain (dBi)	Polarization (H/V)	Result
3819	-56.19	-13	-43.19	-76.97	-62.87	1.70	8.38	H	Pass
5730	-53.19	-13	-40.19	-77.96	-60.22	2.76	9.79	H	Pass
7639	-51.16	-13	-38.16	-78.66	-60.66	2.38	11.88	H	Pass

Band :	GSM1900						Temperature :	21~24°C	
Test Mode :	GPRS class 8 Link (GMSK) for Adapter 1						Relative Humidity :	46~55%	
Test Engineer :	Nick Yu, James Chiu and Ken Wu						Polarization :	Vertical	
Remark :	Spurious emissions within 30-1000MHz were found more than 20dB below limit line.								
Frequency (MHz)	EIRP (dBm)	Limit (dBm)	Over Limit (dB)	SPA Reading (dBm)	S.G. Power (dBm)	TX Cable loss (dB)	TX Antenna Gain (dBi)	Polarization (H/V)	Result
3819	-55.97	-13	-42.97	-77.2	-62.65	1.70	8.38	V	Pass
5730	-46.78	-13	-33.78	-72.27	-53.81	2.76	9.79	V	Pass
7639	-49.38	-13	-36.38	-78.6	-58.88	2.38	11.88	V	Pass



<Low Channel>

Band :	GSM1900		Temperature :	21~24°C					
Test Mode :	EDGE class 8 Link (8PSK) for Adapter 1		Relative Humidity :	46~55%					
Test Engineer :	Nick Yu, James Chiu and Ken Wu		Polarization :	Horizontal					
Remark :	Spurious emissions within 30-1000MHz were found more than 20dB below limit line.								
Frequency (MHz)	EIRP (dBm)	Limit (dBm)	Over Limit (dB)	SPA Reading (dBm)	S.G. Power (dBm)	TX Cable loss (dB)	TX Antenna Gain (dBi)	Polarization (H/V)	Result
3700	-58.51	-13	-45.51	-77.53	-65.08	1.67	8.24	H	Pass
5550	-53.81	-13	-40.81	-78.36	-60.88	2.65	9.72	H	Pass
7400	-52.57	-13	-39.57	-78.87	-61.71	2.46	11.60	H	Pass

Band :	GSM1900		Temperature :	21~24°C					
Test Mode :	EDGE class 8 Link (8PSK) for Adapter 1		Relative Humidity :	46~55%					
Test Engineer :	Nick Yu, James Chiu and Ken Wu		Polarization :	Vertical					
Remark :	Spurious emissions within 30-1000MHz were found more than 20dB below limit line.								
Frequency (MHz)	EIRP (dBm)	Limit (dBm)	Over Limit (dB)	SPA Reading (dBm)	S.G. Power (dBm)	TX Cable loss (dB)	TX Antenna Gain (dBi)	Polarization (H/V)	Result
3700	-57.64	-13	-44.64	-77.74	-64.21	1.67	8.24	V	Pass
5550	-52.74	-13	-39.74	-78.43	-59.81	2.65	9.72	V	Pass
7400	-50.67	-13	-37.67	-78.72	-59.81	2.46	11.60	V	Pass



<Middle Channel>

Band :	GSM1900		Temperature :	21~24°C					
Test Mode :	EDGE class 8 Link (8PSK) for Adapter 1		Relative Humidity :	46~55%					
Test Engineer :	Nick Yu, James Chiu and Ken Wu		Polarization :	Horizontal					
Remark :	Spurious emissions within 30-1000MHz were found more than 20dB below limit line.								
Frequency (MHz)	EIRP (dBm)	Limit (dBm)	Over Limit (dB)	SPA Reading (dBm)	S.G. Power (dBm)	TX Cable loss (dB)	TX Antenna Gain (dBi)	Polarization (H/V)	Result
3763	-57.45	-13	-44.45	-77.28	-64.08	1.69	8.32	H	Pass
5640	-53.86	-13	-40.86	-78.41	-60.91	2.71	9.76	H	Pass
7520	-51.92	-13	-38.92	-79.02	-61.31	2.42	11.81	H	Pass

Band :	GSM1900		Temperature :	21~24°C					
Test Mode :	EDGE class 8 Link (8PSK) for Adapter 1		Relative Humidity :	46~55%					
Test Engineer :	Nick Yu, James Chiu and Ken Wu		Polarization :	Vertical					
Remark :	Spurious emissions within 30-1000MHz were found more than 20dB below limit line.								
Frequency (MHz)	EIRP (dBm)	Limit (dBm)	Over Limit (dB)	SPA Reading (dBm)	S.G. Power (dBm)	TX Cable loss (dB)	TX Antenna Gain (dBi)	Polarization (H/V)	Result
3763	-56.88	-13	-43.88	-77.43	-63.51	1.69	8.32	V	Pass
5640	-52.39	-13	-39.39	-78.05	-59.44	2.71	9.76	V	Pass
7520	-50.12	-13	-37.12	-78.84	-59.51	2.42	11.81	V	Pass



<High Channel>

Band :	GSM1900	Temperature :	21~24°C						
Test Mode :	EDGE class 8 Link (8PSK) for Adapter 1	Relative Humidity :	46~55%						
Test Engineer :	Nick Yu, James Chiu and Ken Wu	Polarization :	Horizontal						
Remark :	Spurious emissions within 30-1000MHz were found more than 20dB below limit line.								
Frequency (MHz)	EIRP (dBm)	Limit (dBm)	Over Limit (dB)	SPA Reading (dBm)	S.G. Power (dBm)	TX Cable loss (dB)	TX Antenna Gain (dBi)	Polarization (H/V)	Result
3819	-56.53	-13	-43.53	-77.29	-63.21	1.70	8.38	H	Pass
5729	-53.85	-13	-40.85	-78.38	-60.88	2.76	9.79	H	Pass
7639	-50.91	-13	-37.91	-78.5	-60.41	2.38	11.88	H	Pass

Band :	GSM1900	Temperature :	21~24°C						
Test Mode :	EDGE class 8 Link (8PSK) for Adapter 1	Relative Humidity :	46~55%						
Test Engineer :	Nick Yu, James Chiu and Ken Wu	Polarization :	Vertical						
Remark :	Spurious emissions within 30-1000MHz were found more than 20dB below limit line.								
Frequency (MHz)	EIRP (dBm)	Limit (dBm)	Over Limit (dB)	SPA Reading (dBm)	S.G. Power (dBm)	TX Cable loss (dB)	TX Antenna Gain (dBi)	Polarization (H/V)	Result
3819	-55.63	-13	-42.63	-76.9	-62.31	1.70	8.38	V	Pass
5729	-52.88	-13	-39.88	-78.43	-59.91	2.76	9.79	V	Pass
7639	-48.99	-13	-35.99	-78.16	-58.49	2.38	11.88	V	Pass



<Low Channel>

Band :	WCDMA Band V		Temperature :	21~24°C					
Test Mode :	RMC 12.2Kbps Link (QPSK) for Adapter 1		Relative Humidity :	46~55%					
Test Engineer :	Nick Yu, James Chiu and Ken Wu		Polarization :	Horizontal					
Remark :	Spurious emissions within 30-1000MHz were found more than 20dB below limit line.								
Frequency (MHz)	ERP (dBm)	Limit (dBm)	Over Limit (dB)	SPA Reading (dBm)	S.G. Power (dBm)	TX Cable loss (dB)	TX Antenna Gain (dBi)	Polarization (H/V)	Result
1648	-64.12	-13	-51.12	-75.06	-65.88	0.98	4.89	H	Pass
2472	-59.71	-13	-46.71	-76.09	-61.59	1.28	5.32	H	Pass
3296	-59.63	-13	-46.63	-77.06	-63.04	1.54	7.10	H	Pass

Band :	WCDMA Band V		Temperature :	21~24°C					
Test Mode :	RMC 12.2Kbps Link (QPSK) for Adapter 1		Relative Humidity :	46~55%					
Test Engineer :	Nick Yu, James Chiu and Ken Wu		Polarization :	Vertical					
Remark :	Spurious emissions within 30-1000MHz were found more than 20dB below limit line.								
Frequency (MHz)	ERP (dBm)	Limit (dBm)	Over Limit (dB)	SPA Reading (dBm)	S.G. Power (dBm)	TX Cable loss (dB)	TX Antenna Gain (dBi)	Polarization (H/V)	Result
1648	-62.93	-13	-49.93	-74.8	-64.69	0.98	4.89	V	Pass
2472	-58.01	-13	-45.01	-75.73	-59.89	1.28	5.32	V	Pass
3296	-57.68	-13	-44.68	-76.61	-61.09	1.54	7.10	V	Pass



<Middle Channel>

Band :	WCDMA Band V		Temperature :	21~24°C					
Test Mode :	RMC 12.2Kbps Link (QPSK) for Adapter 1		Relative Humidity :	46~55%					
Test Engineer :	Nick Yu, James Chiu and Ken Wu		Polarization :	Horizontal					
Remark :	Spurious emissions within 30-1000MHz were found more than 20dB below limit line.								
Frequency (MHz)	ERP (dBm)	Limit (dBm)	Over Limit (dB)	SPA Reading (dBm)	S.G. Power (dBm)	TX Cable loss (dB)	TX Antenna Gain (dBi)	Polarization (H/V)	Result
1672	-63.63	-13	-50.63	-74.85	-65.31	0.99	4.82	H	Pass
2512	-59.54	-13	-46.54	-76.07	-61.51	1.29	5.41	H	Pass
3344	-59.55	-13	-46.55	-76.98	-63.16	1.56	7.31	H	Pass

Band :	WCDMA Band V		Temperature :	21~24°C					
Test Mode :	RMC 12.2Kbps Link (QPSK) for Adapter 1		Relative Humidity :	46~55%					
Test Engineer :	Nick Yu, James Chiu and Ken Wu		Polarization :	Vertical					
Remark :	Spurious emissions within 30-1000MHz were found more than 20dB below limit line.								
Frequency (MHz)	ERP (dBm)	Limit (dBm)	Over Limit (dB)	SPA Reading (dBm)	S.G. Power (dBm)	TX Cable loss (dB)	TX Antenna Gain (dBi)	Polarization (H/V)	Result
1672	-62.93	-13	-49.93	-74.85	-64.61	0.99	4.82	V	Pass
2512	-57.84	-13	-44.84	-75.81	-59.81	1.29	5.41	V	Pass
3344	-57.83	-13	-44.83	-76.72	-61.44	1.56	7.31	V	Pass



<High Channel>

Band :	WCDMA Band V		Temperature :	21~24°C					
Test Mode :	RMC 12.2Kbps Link (QPSK) for Adapter 1		Relative Humidity :	46~55%					
Test Engineer :	Nick Yu, James Chiu and Ken Wu		Polarization :	Horizontal					
Remark :	Spurious emissions within 30-1000MHz were found more than 20dB below limit line.								
Frequency (MHz)	ERP (dBm)	Limit (dBm)	Over Limit (dB)	SPA Reading (dBm)	S.G. Power (dBm)	TX Cable loss (dB)	TX Antenna Gain (dBi)	Polarization (H/V)	Result
1696	-63.79	-13	-50.79	-75.47	-65.39	1.00	4.75	H	Pass
2544	-59.41	-13	-46.41	-76.09	-61.39	1.30	5.44	H	Pass
3392	-59.26	-13	-46.26	-76.76	-63.06	1.57	7.52	H	Pass

Band :	WCDMA Band V		Temperature :	21~24°C					
Test Mode :	RMC 12.2Kbps Link (QPSK) for Adapter 1		Relative Humidity :	46~55%					
Test Engineer :	Nick Yu, James Chiu and Ken Wu		Polarization :	Vertical					
Remark :	Spurious emissions within 30-1000MHz were found more than 20dB below limit line.								
Frequency (MHz)	ERP (dBm)	Limit (dBm)	Over Limit (dB)	SPA Reading (dBm)	S.G. Power (dBm)	TX Cable loss (dB)	TX Antenna Gain (dBi)	Polarization (H/V)	Result
1696	-63.03	-13	-50.03	-75.44	-64.63	1.00	4.75	V	Pass
2544	-58.24	-13	-45.24	-76.33	-60.22	1.30	5.44	V	Pass
3392	-58.29	-13	-45.29	-77.06	-62.09	1.57	7.52	V	Pass



<Low Channel>

Band :	WCDMA Band IV						Temperature :	21~24°C		
Test Mode :	RMC 12.2Kbps Link (QPSK) for Adapter 1						Relative Humidity :	46~55%		
Test Engineer :	Nick Yu, James Chiu and Ken Wu						Polarization :	Horizontal		
Remark :	Spurious emissions within 30-1000MHz were found more than 20dB below limit line.									
Frequency (MHz)	EIRP (dBm)	Limit (dBm)	Over Limit (dB)	SPA Reading (dBm)	S.G. Power (dBm)	TX Cable loss (dB)	TX Antenna Gain (dBi)	Polarization (H/V)	Result	
3427	-58.80	-13	-45.80	-76.7	-64.9	1.58	7.68	H	Pass	
5137	-54.42	-13	-41.42	-78.04	-61.7	2.42	9.70	H	Pass	
6850	-52.02	-13	-39.02	-78.44	-60	2.64	10.62	H	Pass	

Band :	WCDMA Band IV						Temperature :	21~24°C		
Test Mode :	RMC 12.2Kbps Link (QPSK) for Adapter 1						Relative Humidity :	46~55%		
Test Engineer :	Nick Yu, James Chiu and Ken Wu						Polarization :	Vertical		
Remark :	Spurious emissions within 30-1000MHz were found more than 20dB below limit line.									
Frequency (MHz)	EIRP (dBm)	Limit (dBm)	Over Limit (dB)	SPA Reading (dBm)	S.G. Power (dBm)	TX Cable loss (dB)	TX Antenna Gain (dBi)	Polarization (H/V)	Result	
3427	-57.40	-13	-44.40	-76.63	-63.5	1.58	7.68	V	Pass	
5137	-53.82	-13	-40.82	-78.42	-61.1	2.42	9.70	V	Pass	
6850	-50.42	-13	-37.42	-77.91	-58.4	2.64	10.62	V	Pass	



<Middle Channel>

Band :	WCDMA Band IV						Temperature :	21~24°C		
Test Mode :	RMC 12.2Kbps Link (QPSK) for Adapter 1						Relative Humidity :	46~55%		
Test Engineer :	Nick Yu, James Chiu and Ken Wu						Polarization :	Horizontal		
Remark :	Spurious emissions within 30-1000MHz were found more than 20dB below limit line.									
Frequency (MHz)	EIRP (dBm)	Limit (dBm)	Over Limit (dB)	SPA Reading (dBm)	S.G. Power (dBm)	TX Cable loss (dB)	TX Antenna Gain (dBi)	Polarization (H/V)	Result	
3462	-58.87	-13	-45.87	-76.59	-65.11	1.59	7.83	H	Pass	
5198	-54.96	-13	-41.96	-78.4	-62.21	2.45	9.70	H	Pass	
6927	-52.01	-13	-39.01	-78.39	-60.11	2.61	10.71	H	Pass	

Band :	WCDMA Band IV						Temperature :	21~24°C		
Test Mode :	RMC 12.2Kbps Link (QPSK) for Adapter 1						Relative Humidity :	46~55%		
Test Engineer :	Nick Yu, James Chiu and Ken Wu						Polarization :	Vertical		
Remark :	Spurious emissions within 30-1000MHz were found more than 20dB below limit line.									
Frequency (MHz)	EIRP (dBm)	Limit (dBm)	Over Limit (dB)	SPA Reading (dBm)	S.G. Power (dBm)	TX Cable loss (dB)	TX Antenna Gain (dBi)	Polarization (H/V)	Result	
3462	-57.67	-13	-44.67	-76.52	-63.91	1.59	7.83	V	Pass	
5198	-53.66	-13	-40.66	-78.02	-60.91	2.45	9.70	V	Pass	
6927	-51.08	-13	-38.08	-78.38	-59.18	2.61	10.71	V	Pass	



<High Channel>

Band :	WCDMA Band IV						Temperature :	21~24°C		
Test Mode :	RMC 12.2Kbps Link (QPSK) for Adapter 1						Relative Humidity :	46~55%		
Test Engineer :	Nick Yu, James Chiu and Ken Wu						Polarization :	Horizontal		
Remark :	Spurious emissions within 30-1000MHz were found more than 20dB below limit line.									
Frequency (MHz)	EIRP (dBm)	Limit (dBm)	Over Limit (dB)	SPA Reading (dBm)	S.G. Power (dBm)	TX Cable loss (dB)	TX Antenna Gain (dBi)	Polarization (H/V)	Result	
3504	-58.70	-13	-45.70	-76.6	-65.1	1.61	8.00	H	Pass	
5258	-53.89	-13	-40.89	-78.15	-61.1	2.49	9.70	H	Pass	
7010	-51.97	-13	-38.97	-78.34	-60.2	2.59	10.82	H	Pass	

Band :	WCDMA Band IV						Temperature :	21~24°C		
Test Mode :	RMC 12.2Kbps Link (QPSK) for Adapter 1						Relative Humidity :	46~55%		
Test Engineer :	Nick Yu, James Chiu and Ken Wu						Polarization :	Vertical		
Remark :	Spurious emissions within 30-1000MHz were found more than 20dB below limit line.									
Frequency (MHz)	EIRP (dBm)	Limit (dBm)	Over Limit (dB)	SPA Reading (dBm)	S.G. Power (dBm)	TX Cable loss (dB)	TX Antenna Gain (dBi)	Polarization (H/V)	Result	
3504	-56.90	-13	-43.90	-76.55	-63.3	1.61	8.00	V	Pass	
5258	-52.99	-13	-39.99	-78.18	-60.2	2.49	9.70	V	Pass	
7010	-50.87	-13	-37.87	-78.36	-59.1	2.59	10.82	V	Pass	



<Low Channel>

Band :	WCDMA Band II	Temperature :	21~24°C						
Test Mode :	RMC 12.2Kbps Link (QPSK) for Adapter 1	Relative Humidity :	46~55%						
Test Engineer :	Nick Yu, James Chiu and Ken Wu	Polarization :	Horizontal						
Remark :	Spurious emissions within 30-1000MHz were found more than 20dB below limit line.								
Frequency (MHz)	EIRP (dBm)	Limit (dBm)	Over Limit (dB)	SPA Reading (dBm)	S.G. Power (dBm)	TX Cable loss (dB)	TX Antenna Gain (dBi)	Polarization (H/V)	Result
3707	-58.48	-13	-45.48	-77.62	-65.06	1.67	8.25	H	Pass
5557	-53.85	-13	-40.85	-78.25	-60.91	2.66	9.72	H	Pass
7409	-52.38	-13	-39.38	-78.67	-61.54	2.46	11.62	H	Pass

Band :	WCDMA Band II	Temperature :	21~24°C						
Test Mode :	RMC 12.2Kbps Link (QPSK) for Adapter 1	Relative Humidity :	46~55%						
Test Engineer :	Nick Yu, James Chiu and Ken Wu	Polarization :	Vertical						
Remark :	Spurious emissions within 30-1000MHz were found more than 20dB below limit line.								
Frequency (MHz)	EIRP (dBm)	Limit (dBm)	Over Limit (dB)	SPA Reading (dBm)	S.G. Power (dBm)	TX Cable loss (dB)	TX Antenna Gain (dBi)	Polarization (H/V)	Result
3707	-57.48	-13	-44.48	-77.55	-64.06	1.67	8.25	V	Pass
5557	-52.75	-13	-39.75	-78.51	-59.81	2.66	9.72	V	Pass
7409	-50.49	-13	-37.49	-78.6	-59.65	2.46	11.62	V	Pass



<Middle Channel>

Band :	WCDMA Band II		Temperature :	21~24°C					
Test Mode :	RMC 12.2Kbps Link (QPSK) for Adapter 1		Relative Humidity :	46~55%					
Test Engineer :	Nick Yu, James Chiu and Ken Wu		Polarization :	Horizontal					
Remark :	Spurious emissions within 30-1000MHz were found more than 20dB below limit line.								
Frequency (MHz)	EIRP (dBm)	Limit (dBm)	Over Limit (dB)	SPA Reading (dBm)	S.G. Power (dBm)	TX Cable loss (dB)	TX Antenna Gain (dBi)	Polarization (H/V)	Result
3763	-57.48	-13	-44.48	-77.31	-64.11	1.69	8.32	H	Pass
5640	-53.97	-13	-40.97	-78.5	-61.02	2.71	9.76	H	Pass
7520	-52.02	-13	-39.02	-79.07	-61.41	2.42	11.81	H	Pass

Band :	WCDMA Band II		Temperature :	21~24°C					
Test Mode :	RMC 12.2Kbps Link (QPSK) for Adapter 1		Relative Humidity :	46~55%					
Test Engineer :	Nick Yu, James Chiu and Ken Wu		Polarization :	Vertical					
Remark :	Spurious emissions within 30-1000MHz were found more than 20dB below limit line.								
Frequency (MHz)	EIRP (dBm)	Limit (dBm)	Over Limit (dB)	SPA Reading (dBm)	S.G. Power (dBm)	TX Cable loss (dB)	TX Antenna Gain (dBi)	Polarization (H/V)	Result
3763	-56.69	-13	-43.69	-77.19	-63.32	1.69	8.32	V	Pass
5640	-52.76	-13	-39.76	-78.37	-59.81	2.71	9.76	V	Pass
7520	-50.42	-13	-37.42	-79.03	-59.81	2.42	11.81	V	Pass



<High Channel>

Band :	WCDMA Band II						Temperature :	21~24°C		
Test Mode :	RMC 12.2Kbps Link (QPSK) for Adapter 1						Relative Humidity :	46~55%		
Test Engineer :	Nick Yu, James Chiu and Ken Wu						Polarization :	Horizontal		
Remark :	Spurious emissions within 30-1000MHz were found more than 20dB below limit line.									
Frequency (MHz)	EIRP (dBm)	Limit (dBm)	Over Limit (dB)	SPA Reading (dBm)	S.G. Power (dBm)	TX Cable loss (dB)	TX Antenna Gain (dBi)	Polarization (H/V)	Result	
3812	-56.44	-13	-43.44	-77.01	-63.11	1.70	8.37	H	Pass	
5722	-53.98	-13	-40.98	-78.61	-61.02	2.75	9.79	H	Pass	
7630	-51.32	-13	-38.32	-78.73	-60.81	2.39	11.88	H	Pass	

Band :	WCDMA Band II						Temperature :	21~24°C		
Test Mode :	RMC 12.2Kbps Link (QPSK) for Adapter 1						Relative Humidity :	46~55%		
Test Engineer :	Nick Yu, James Chiu and Ken Wu						Polarization :	Vertical		
Remark :	Spurious emissions within 30-1000MHz were found more than 20dB below limit line.									
Frequency (MHz)	EIRP (dBm)	Limit (dBm)	Over Limit (dB)	SPA Reading (dBm)	S.G. Power (dBm)	TX Cable loss (dB)	TX Antenna Gain (dBi)	Polarization (H/V)	Result	
3812	-55.74	-13	-42.74	-76.88	-62.41	1.70	8.37	V	Pass	
5722	-52.98	-13	-39.98	-78.49	-60.02	2.75	9.79	V	Pass	
7630	-49.59	-13	-36.59	-78.75	-59.08	2.39	11.88	V	Pass	



3.8 Frequency Stability Measurement

3.8.1 Description of Frequency Stability Measurement

The frequency stability shall be measured by variation of ambient temperature and variation of primary supply voltage to ensure that the fundamental emission stays within the authorized frequency block. The frequency stability of the transmitter shall be maintained within $\pm 0.00025\%$ ($\pm 2.5\text{ppm}$) of the center frequency.

3.8.2 Measuring Instruments

The measuring equipment is listed in the section 4 of this test report.

3.8.3 Test Procedures for Temperature Variation

1. The testing follows FCC KDB 971168 v02r02 Section 9.0.
2. The EUT was set up in the thermal chamber and connected with the system simulator.
3. With power OFF, the temperature was decreased to -30°C and the EUT was stabilized before testing. Power was applied and the maximum change in frequency was recorded within one minute.
4. With power OFF, the temperature was raised in 10°C steps up to 50°C . The EUT was stabilized at each step for at least half an hour. Power was applied and the maximum frequency change was recorded within one minute.

3.8.4 Test Procedures for Voltage Variation

1. The testing follows FCC KDB 971168 v02r02 Section 9.0.
2. The EUT was placed in a temperature chamber at $25\pm 5^{\circ}\text{C}$ and connected with the system simulator.
3. The power supply voltage to the EUT was varied from BEP to 115% of the nominal value measured at the input to the EUT.
4. The variation in frequency was measured for the worst case.

3.8.5 Test Setup

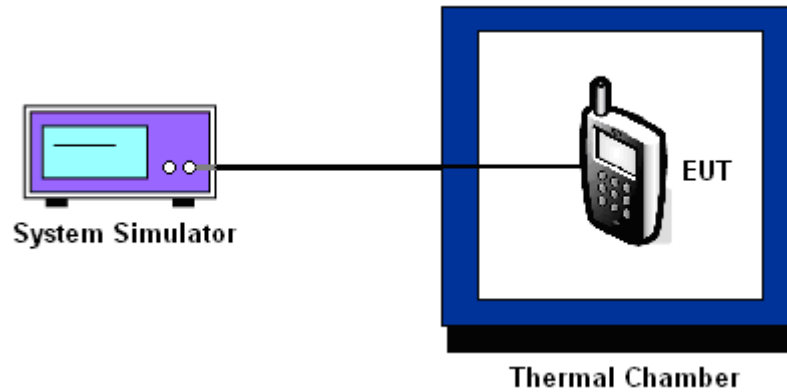

3.8.6 Test Result of Temperature Variation

Band :	GSM 850	Channel :	189
Limit (ppm) :	2.5	Frequency :	836.4 MHz

Temperature (°C)	GPRS class 8	EDGE class 8	Result
	Deviation (ppm)	Deviation (ppm)	
50	0.0024	0.0012	PASS
40	0.0024	0.0024	
30	0.0012	0.0048	
20(Ref.)	0.0000	0.0000	
10	0.0012	0.0060	
0	0.0036	0.0036	
-10	0.0024	0.0048	
-20	0.0000	0.0060	
-30	0.0143	0.0132	

Note: The frequency fundamental emissions stay within the authorized frequency block based on the frequency deviation measured is small.



Band :	GSM 1900	Channel :	661
Limit (ppm) :	within authorized band	Frequency :	1880.0 MHz

Temperature (°C)	GPRS class 8	EDGE class 8	Result
	Deviation (ppm)	Deviation (ppm)	
50	0.0043	0.0011	PASS
40	0.0059	0.0021	
30	0.0021	0.0011	
20(Ref.)	0.0000	0.0000	
10	0.0000	0.0048	
0	0.0032	0.0032	
-10	0.0027	0.0011	
-20	0.0043	0.0021	
-30	0.0005	0.0037	

Note: The frequency fundamental emissions stay within the authorized frequency block based on the frequency deviation measured is small.

Band :	WCDMA Band V	Channel :	4182
Limit (ppm) :	2.5	Frequency :	836.4 MHz

Temperature (°C)	RMC 12.2Kbps	Result
	Deviation (ppm)	
50	0.0024	PASS
40	0.0132	
30	0.0132	
20(Ref.)	0.0000	
10	0.0167	
0	0.0143	
-10	0.0012	
-20	0.0012	
-30	0.0036	

Note: The frequency fundamental emissions stay within the authorized frequency block based on the frequency deviation measured is small.



Band :	WCDMA Band IV	Channel :	1413
Limit (ppm) :	within authorized band	Frequency :	1732.6 MHz

Temperature (°C)	RMC 12.2Kbps	Result
	Deviation (ppm)	
50	0.0017	PASS
40	0.0006	
30	0.0017	
20(Ref.)	0.0000	
10	0.0006	
0	0.0029	
-10	0.0000	
-20	0.0006	
-30	0.0023	

Note: The frequency fundamental emissions stay within the authorized frequency block based on the frequency deviation measured is small.

Band :	WCDMA Band II	Channel :	9400
Limit (ppm) :	within authorized band	Frequency :	1880.0 MHz

Temperature (°C)	RMC 12.2Kbps	Result
	Deviation (ppm)	
50	0.0005	PASS
40	0.0069	
30	0.0005	
20(Ref.)	0.0000	
10	0.0016	
0	0.0074	
-10	0.0016	
-20	0.0021	
-30	0.0005	

Note: The frequency fundamental emissions stay within the authorized frequency block based on the frequency deviation measured is small.



3.8.7 Test Result of Voltage Variation

Band & Channel	Mode	Voltage (Volt)	Deviation (ppm)	Limit (ppm)	Result
GSM 850 CH189	GPRS class 8	4.35	0.0000	2.5	PASS
		3.87	0.0024		
		BEP	0.0000		
	EDGE class 8	4.35	0.0048		
		3.87	0.0012		
		BEP	0.0024		
GSM 1900 CH661	GPRS class 8	4.35	0.0016	(Note 3.)	
		3.87	0.0000		
		BEP	0.0011		
	EDGE class 8	4.35	0.0037		
		3.87	0.0059		
		BEP	0.0053		
WCDMA Band V CH4182	RMC 12.2Kbps	4.35	0.0012	2.5	
		3.87	0.0120		
		BEP	0.0132		
WCDMA Band IV CH1413	RMC 12.2Kbps	4.35	0.0017	(Note 3.)	
		3.87	0.0017		
		BEP	0.0006		
WCDMA Band II CH9400	RMC 12.2Kbps	4.35	0.0064	(Note 3.)	
		3.87	0.0016		
		BEP	0.0005		

Note:

1. Normal Voltage = 3.87V.
2. Battery End Point (BEP) = 3.40 V.
3. The frequency fundamental emissions stay within the authorized frequency block based on the frequency deviation measured is small.



4 List of Measuring Equipment

Instrument	Manufacturer	Model No.	Serial No.	Characteristics	Calibration Date	Test Date	Due Date	Remark
Spectrum Analyzer	Rohde & Schwarz	FSP30	101329	9kHz~30GHz	Jun. 14, 2014	Apr. 21, 2015~ Apr. 28, 2015	Jun. 13, 2015	Conducted (TH03-HY)
Base Station(Measu	Rohde & Schwarz	CMU200	117995	GSM / GPRS / WCDMA / CDMA	Jul. 29, 2014	Apr. 21, 2015~ Apr. 28, 2015	Jul. 28, 2015	Conducted (TH03-HY)
Temperature Chamber	ESPEC	SU-641	92013721	-30 ~70 degree	Dec. 01, 2014	Apr. 21, 2015~ Apr. 28, 2015	Nov. 30, 2015	Conducted (TH03-HY)
Bilog Antenna	Schaffner	CBL6111C	2726	30MHz ~ 1GHz	Sep. 27, 2014	Apr. 20, 2015 ~ May 20, 2015	Sep. 26, 2015	Radiation (03CH07-HY)
Double Ridge Horn Antenna	ESCO	3117	00075962	1GHz ~ 18GHz	Aug. 19, 2014	Apr. 20, 2015 ~ May 20, 2015	Aug. 18, 2015	Radiation (03CH07-HY)
EMI Test Receiver	Rohde & Schwarz	ESCI 7	100724	9kHz~7GHz	Aug. 30, 2014	Apr. 20, 2015 ~ May 20, 2015	Aug. 29, 2015	Radiation (03CH07-HY)
Horn Antenna	SCHWARZBECK	BBHA 9120D	9120D-1328	1GHz ~ 18GHz	Nov. 05, 2014	Apr. 20, 2015 ~ May 20, 2015	Nov. 04, 2015	Radiation (03CH07-HY)
Horn Antenna	SCHWARZBECK	BBHA 9170	BBHA917058 4	18GHz- 40GHz	Nov. 03, 2014	Apr. 20, 2015 ~ May 20, 2015	Nov. 02, 2015	Radiation (03CH07-HY)
Preamplifier	COM-POWER	PA-103A	161241	10MHz-1000MHz	Mar. 12, 2015	Apr. 20, 2015 ~ May 20, 2015	Mar. 11, 2016	Radiation (03CH07-HY)
Preamplifier	Agilent	8449B	3008A02362	1GHz~ 26.5GHz	Oct. 21, 2014	Apr. 20, 2015 ~ May 20, 2015	Oct. 20, 2015	Radiation (03CH07-HY)
Signal Analyzer	Rohde & Schwarz	FSV 30	101749	10Hz~30GHz	Mar. 10, 2015	Apr. 20, 2015 ~ May 20, 2015	Mar. 09, 2016	Radiation (03CH07-HY)
Antenna Mast	Max-Full	MFA520BS	N/A	1m~4m	N/A	Apr. 20, 2015 ~ May 20, 2015	N/A	Radiation (03CH07-HY)
Turn Table	ChainTek	Chaintek 3000	N/A	0~360 degree	N/A	Apr. 20, 2015 ~ May 20, 2015	N/A	Radiation (03CH07-HY)
Signal Generator	Rohde & Schwarz	SMF100A	101107	100kHz~40GHz	May 23, 2014	Apr. 20, 2015 ~ May 20, 2015	May 22, 2015	Radiation (03CH07-HY)



5 Uncertainty of Evaluation

Uncertainty of Radiated Emission Measurement (30 MHz ~ 1000 MHz)

Measuring Uncertainty for a Level of Confidence of 95% ($U = 2Uc(y)$)	4.50
---	------