



FCC RF Test Report

APPLICANT : Motorola Mobility, LLC
EQUIPMENT : Mobile Cellular Phone
BRAND NAME : Motorola
MODEL NAME : 5136
FCC ID : IHDT56UC1
STANDARD : FCC Part 15 Subpart C §15.247
CLASSIFICATION : (DTS) Digital Transmission System

The product was received on Apr. 16, 2015. We, SPORTON INTERNATIONAL INC., would like to declare that the tested sample has been evaluated in accordance with the test procedures and has been in compliance with the applicable technical standards.

The test results in this report apply exclusively to the tested model / sample. Without written approval of SPORTON INTERNATIONAL INC., the test report shall not be reproduced except in full.

Reviewed by: Joseph Lin / Supervisor

Approved by: Jones Tsai / Manager



SPORTON INTERNATIONAL INC.

No. 52, Hwa Ya 1st Rd., Hwa Ya Technology Park, Kwei-Shan District, Tao Yuan City, Taiwan, R.O.C.

SPORTON INTERNATIONAL INC.

TEL : 886-3-327-3456

FAX : 886-3-328-4978

FCC ID : IHDT56UC1

Page Number : 1 of 4

Report Issued Date : Jun. 18, 2015

Report Version : Rev. 01

Report Template No.: BU5-FR15CWLAN Version 1.0



TABLE OF CONTENTS

REVISION HISTORY..... 3

1 GENERAL DESCRIPTION 4

 1.1 Applicant 4

 1.2 Manufacturer..... 4

 1.3 Product Feature of Equipment Under Test..... 4

 1.4 Product Specification subjective to this standard 4

 1.5 Modification of EUT 4

APPENDIX A. ORIGINAL REPORT



1 General Description

1.1 Applicant

Motorola Mobility, LLC

222 W Merchandise Mart Plaza, Suite 1800, Chicago, IL 60654, United States

1.2 Manufacturer

Motorola Mobility, LLC

222 W Merchandise Mart Plaza, Suite 1800, Chicago, IL 60654, United States

1.3 Product Feature of Equipment Under Test

Product Feature	
Equipment	Mobile Cellular Phone
Brand Name	Motorola
Model Name	5136
FCC ID	IHDT56UC1
EUT supports Radios application	CDMA/EV-DO/GSM/EGPRS/WCDMA/HSPA/LTE/NFC 2.4GHz WLAN 11b/g/n HT20 WLAN 11ac VHT20 5GHz WLAN 11a/n HT20/HT40 WLAN 11ac VHT20/VHT40/VHT80 Bluetooth v3.0 EDR Bluetooth v4.1 - LE
HW Version	P2B
EUT Stage	Identical Prototype

Remark: The above EUT's information was declared by manufacturer. Please refer to the specifications or user's manual for more detailed description.

1.4 Product Specification subjective to this standard

Product Specification subjective to this standard	
Tx/Rx Channel Frequency Range	2412 MHz ~ 2462 MHz
Antenna Type	IFA Antenna (The antenna peak gain of EUT is less than 6 dBi)
Type of Modulation	802.11b : DSSS (DBPSK / DQPSK / CCK) 802.11g/n : OFDM (BPSK / QPSK / 16QAM / 64QAM)

1.5 Modification of EUT

No modifications are made to the EUT during all test items.



Appendix A. Original Report

Please refer to Sporton report number FR541573C as below.



FCC RF Test Report

APPLICANT : Motorola Mobility, LLC
EQUIPMENT : Mobile Cellular Phone
BRAND NAME : Motorola
MODEL NAME : 5137
FCC ID : IHDT56UC2
STANDARD : FCC Part 15 Subpart C §15.247
CLASSIFICATION : (DTS) Digital Transmission System

The product was received on Apr. 15, 2015 and testing was completed on May 17, 2015. We, SPORTON INTERNATIONAL INC., would like to declare that the tested sample has been evaluated in accordance with the test procedures and has been in compliance with the applicable technical standards.

The test results in this report apply exclusively to the tested model / sample. Without written approval of SPORTON INTERNATIONAL INC., the test report shall not be reproduced except in full.

Reviewed by: Joseph Lin / Supervisor

Approved by: Jones Tsai / Manager



SPORTON INTERNATIONAL INC.

No. 52, Hwa Ya 1st Rd., Hwa Ya Technology Park, Kwei-Shan District, Tao Yuan City, Taiwan, R.O.C.



TABLE OF CONTENTS

REVISION HISTORY.....3

SUMMARY OF TEST RESULT4

1 GENERAL DESCRIPTION.....5

 1.1 Applicant.....5

 1.2 Manufacturer.....5

 1.3 Product Feature of Equipment Under Test.....5

 1.4 Product Specification subjective to this standard7

 1.5 Modification of EUT7

 1.6 Testing Location8

 1.7 Applicable Standards.....8

2 TEST CONFIGURATION OF EQUIPMENT UNDER TEST.....9

 2.1 Carrier Frequency and Channel9

 2.2 Pre-Scanned RF Power.....10

 2.3 Test Mode.....16

 2.4 Connection Diagram of Test System.....17

 2.5 Support Unit used in test configuration and system.....20

 2.6 EUT Operation Test Setup20

 2.7 Measurement Results Explanation Example.....20

3 TEST RESULT.....21

 3.1 6dB Bandwidth Measurement21

 3.2 Peak Output Power Measurement23

 3.3 Power Spectral Density Measurement25

 3.4 Conducted Band Edges and Spurious Emission Measurement27

 3.5 Radiated Band Edges and Spurious Emission Measurement52

 3.6 AC Conducted Emission Measurement.....57

 3.7 Antenna Requirements.....60

4 LIST OF MEASURING EQUIPMENT.....62

5 UNCERTAINTY OF EVALUATION.....63

APPENDIX A. CONDUCTED TEST RESULTS

APPENDIX B. RADIATED TEST RESULTS



SUMMARY OF TEST RESULT

Report Section	FCC Rule	Description	Limit	Result	Remark
3.1	15.247(a)(2)	6dB Bandwidth	$\geq 0.5\text{MHz}$	Pass	-
3.2	15.247(b)	Power Output Measurement	$\leq 30\text{dBm}$	Pass	-
3.3	15.247(e)	Power Spectral Density	$\leq 8\text{dBm}/3\text{kHz}$	Pass	-
3.4	15.247(d)	Conducted Band Edges	$\leq 20\text{dBc}$	Pass	-
		Conducted Spurious Emission		Pass	-
3.5	15.247(d)	Radiated Band Edges and Radiated Spurious Emission	15.209(a) & 15.247(d)	Pass	Under limit 1.02 dB at 4926.000 MHz
3.6	15.207	AC Conducted Emission	15.207(a)	Pass	Under limit 9.50 dB at 2.046 MHz
3.7	15.203 & 15.247(b)	Antenna Requirement	N/A	Pass	-



1 General Description

1.1 Applicant

Motorola Mobility, LLC

222 W Merchandise Mart Plaza, Suite 1800, Chicago, IL 60654, United States

1.2 Manufacturer

Motorola Mobility, LLC

222 W Merchandise Mart Plaza, Suite 1800, Chicago, IL 60654, United States

1.3 Product Feature of Equipment Under Test

Product Feature	
Equipment	Mobile Cellular Phone
Brand Name	Motorola
Model Name	5137
IMEI Code	355486060017664 (Radiation) 355486060017805 (Conduction)
FCC ID	IHDT56UC2
EUT supports Radios application	GSM/EGPRS/WCDMA/HSPA/LTE/NFC 2.4GHz WLAN 11b/g/n HT20 WLAN 11ac VHT20 5GHz WLAN 11a/n HT20/HT40 WLAN 11ac VHT20/VHT40/VHT80 Bluetooth v3.0 EDR Bluetooth v4.1 - LE
HW Version	P2
EUT Stage	Identical Prototype

Remark: The above EUT's information was declared by manufacturer. Please refer to the specifications or user's manual for more detailed description.



Accessory List	
AC Adapter 1	Brand Name : Motorola
	Model Name : SPN5791A
AC Adapter 2	Brand Name : Motorola
	Model Name : SPN5864A
AC Adapter 3	Brand Name : Motorola
	Model Name : SPN5886A
Earphone	Brand Name : Motorola
	Model Name : SJYN1305A
Battery	Brand Name : Motorola
	Model Name : FX30
USB cable	Brand Name : Motorola
	Model Name : SKN6461A



1.4 Product Specification subjective to this standard

Product Specification subjective to this standard			
Tx/Rx Channel Frequency Range	802.11b/g/n/ac : 2412 MHz ~ 2462 MHz		
Maximum (Peak) Output Power to antenna	<p><Ant 1> 802.11b : 20.96 dBm (0.1247 W) 802.11g : 24.69 dBm (0.2944 W) 802.11n HT20 : 24.13 dBm (0.2588 W) 802.11ac VHT20 : 24.18 dBm (0.2618 W)</p> <p><Ant 2> 802.11b : 21.44 dBm (0.1393 W) 802.11g : 24.40 dBm (0.2754 W) 802.11n HT20 : 24.09 dBm (0.2564 W) 802.11ac VHT20 : 24.09 dBm (0.2564 W)</p> <p><Ant 1+2 > 802.11b : 24.45 dBm (0.2786 W) 802.11g : 27.49 dBm (0.5610 W) 802.11n HT20 : 27.22 dBm (0.5272 W) 802.11ac VHT20 : 27.03 dBm (0.5047 W)</p>		
Antenna Type	<p><Ant 1> 802.11b/g/n/ac : IFA Antenna type</p> <p><Ant 2> 802.11b/g/n/ac : IFA Antenna type (The antenna peak gain of EUT is less than 6 dBi)</p>		
Type of Modulation	802.11b : DSSS (DBPSK / DQPSK / CCK) 802.11g/n : OFDM (BPSK / QPSK / 16QAM / 64QAM) 802.11ac : OFDM (BPSK / QPSK / 16QAM / 64QAM / 256QAM)		
Antenna Function for Transmitter		Chain Port 0 Ant. 1	Chain Port 1 Ant. 2
	802.11 b/g	V	V
	802.11 n/ac SISO	V	V
	802.11 n/ac MIMO	V	V

1.5 Modification of EUT

No modifications are made to the EUT during all test items.



1.6 Testing Location

Sporton Lab is accredited to ISO 17025 by Taiwan Accreditation Foundation (TAF code : 1190) and the FCC designation No. TW1022 under the FCC 2.948(e) by Mutual Recognition Agreement (MRA) in FCC Test.

Test Site	SPORTON INTERNATIONAL INC.		
Test Site Location	No. 52, Hwa Ya 1 st Rd., Hwa Ya Technology Park, Kwei-Shan District, Tao Yuan City, Taiwan, R.O.C. TEL: +886-3-327-3456 FAX: +886-3-328-4978		
Test Site No.	Sporton Site No.		
	TH02-HY	CO05-HY	03CH07-HY

Note: The test site complies with ANSI C63.4 2009 requirement.

1.7 Applicable Standards

According to the specifications of the manufacturer, the EUT must comply with the requirements of the following standards:

- ♦ FCC Part 15 Subpart C §15.247
- ♦ FCC KDB Publication No. 558074 D01 DTS Meas. Guidance v03r02
- ♦ FCC KDB 662911 D01 Multiple Transmitter Output v02r01.
- ♦ FCC KDB 644545 D03 Guidance for IEEE 802 11ac New Rules v01
- ♦ ANSI C63.10-2009

Remark:

1. All test items were verified and recorded according to the standards and without any deviation during the test.
2. FCC permits the use of the 1.5 meter table as an alternative in C63.10-2013 through inquiry tracking number 961829.
3. This EUT has also been tested and complied with the requirements of FCC Part 15, Subpart B, recorded in a separate test report.



2 Test Configuration of Equipment Under Test

The EUT has been associated with peripherals and configuration operated in a manner tended to maximize its emission characteristics in a typical application. Frequency range investigated: conducted emission (150 kHz to 30 MHz) and radiated emission (9 kHz to the 10th harmonic of the highest fundamental frequency or to 40 GHz, whichever is lower). For radiated measurement, pre-scanned in three orthogonal panels, X, Y, Z. The worst cases (Y plane) were recorded in this report.

The final configuration from all the combinations and the worst-case data rates were investigated by measuring the maximum power across all the data rates and modulation modes under section 2.2.

Based on the worst configuration found above, the RF power setting is set individually to meet FCC compliance limit for the final conducted and radiated tests shown in section 2.3.

2.1 Carrier Frequency and Channel

Frequency Band	Channel	Freq. (MHz)	Channel	Freq. (MHz)
2400-2483.5 MHz	1	2412	7	2442
	2	2417	8	2447
	3	2422	9	2452
	4	2427	10	2457
	5	2432	11	2462
	6	2437		



2.2 Pre-Scanned RF Power

Preliminary tests were performed in different data rate and data rate associated with the highest power were chosen for full test shown in the following tables.

<Ant. 1>

Channel	Frequency	2.4GHz 802.11b RF Power (dBm)			
		DSSS Data Rate			
		1 Mbps	2 Mbps	5.5 Mbps	11 Mbps
CH 01	2412MHz	20.96	20.88	20.91	20.85
CH 06	2437MHz	20.84	20.82	20.82	20.81
CH 11	2462MHz	20.15	20.10	20.10	20.09

Channel	Frequency	2.4GHz 802.11b Average Power (dBm)			
		DSSS Data Rate			
		1 Mbps	2 Mbps	5.5 Mbps	11 Mbps
CH 01	2412MHz	18.70	18.57	18.66	18.66
CH 06	2437MHz	18.42	18.36	18.43	18.37
CH 11	2462MHz	17.86	17.74	17.81	17.81

Channel	Frequency	2.4GHz 802.11g RF Power (dBm)							
		OFDM Data Rate							
		6 Mbps	9 Mbps	12 Mbps	18 Mbps	24 Mbps	36 Mbps	48 Mbps	54 Mbps
CH 01	2412MHz	20.92	21.25	21.16	21.15	24.30	24.28	24.27	24.21
CH 06	2437MHz	22.64	22.68	22.90	23.50	24.69	24.50	24.34	24.32
CH 11	2462MHz	19.71	19.79	20.00	20.09	23.01	22.83	22.83	22.98

Channel	Frequency	2.4GHz 802.11g Average Power (dBm)							
		OFDM Data Rate							
		6 Mbps	9 Mbps	12 Mbps	18 Mbps	24 Mbps	36 Mbps	48 Mbps	54 Mbps
CH 01	2412MHz	14.72	14.69	14.65	14.75	14.86	14.84	14.85	14.83
CH 06	2437MHz	17.07	17.04	17.01	17.08	16.82	16.60	15.42	15.55
CH 11	2462MHz	13.58	13.65	13.59	13.74	13.92	13.91	13.90	13.91



Channel	Frequency	2.4GHz 802.11n HT20 RF Power (dBm)							
		OFDM Data Rate							
		MCS0	MCS1	MCS2	MCS3	MCS4	MCS5	MCS6	MCS7
CH 01	2412MHz	20.33	20.46	20.25	23.62	23.36	23.52	23.60	23.60
CH 06	2437MHz	22.99	22.81	22.77	24.13	24.08	24.05	24.11	23.77
CH 11	2462MHz	18.71	18.69	19.60	21.92	21.40	21.56	21.60	21.55

Channel	Frequency	2.4GHz 802.11n HT20 Average Power (dBm)							
		OFDM Data Rate							
		MCS0	MCS1	MCS2	MCS3	MCS4	MCS5	MCS6	MCS7
CH 01	2412MHz	13.60	13.33	13.47	14.17	14.14	14.08	14.06	14.07
CH 06	2437MHz	16.94	16.90	16.88	15.74	15.68	15.49	15.48	14.69
CH 11	2462MHz	11.96	11.85	12.08	12.73	12.72	12.70	12.58	12.69

Channel	Frequency	2.4GHz 802.11n VHT20 RF Power (dBm)								
		OFDM Data Rate								
		MCS0	MCS1	MCS2	MCS3	MCS4	MCS5	MCS6	MCS7	MCS8
CH 01	2412MHz	22.98	22.97	22.95	24.18	24.13	24.09	24.14	23.94	23.19
CH 06	2437MHz	22.86	22.85	22.79	24.13	24.12	24.11	24.08	23.79	22.95
CH 11	2462MHz	20.01	19.99	19.89	23.02	22.87	22.87	22.94	22.67	18.63

Channel	Frequency	2.4GHz 802.11n VHT20 Average Power (dBm)								
		OFDM Data Rate								
		MCS0	MCS1	MCS2	MCS3	MCS4	MCS5	MCS6	MCS7	MCS8
CH 01	2412MHz	17.05	16.97	17.02	15.68	15.66	15.65	15.62	14.71	13.65
CH 06	2437MHz	16.92	13.89	16.93	15.59	15.67	15.73	15.71	14.84	13.67
CH 11	2462MHz	13.55	13.37	13.59	14.28	14.19	14.26	14.26	13.74	13.35



<Ant. 2>

Channel	Frequency	2.4GHz 802.11b RF Power (dBm)			
		DSSS Data Rate			
		1 Mbps	2 Mbps	5.5 Mbps	11 Mbps
CH 01	2412MHz	21.44	21.38	21.41	21.40
CH 06	2437MHz	21.36	21.30	21.31	21.29
CH 11	2462MHz	20.53	20.51	20.51	20.50

Channel	Frequency	2.4GHz 802.11b Average Power (dBm)			
		DSSS Data Rate			
		1 Mbps	2 Mbps	5.5 Mbps	11 Mbps
CH 01	2412MHz	19.25	19.21	19.24	19.23
CH 06	2437MHz	19.14	19.10	19.13	19.12
CH 11	2462MHz	18.30	18.22	18.28	18.27

Channel	Frequency	2.4GHz 802.11g RF Power (dBm)							
		OFDM Data Rate							
		6 Mbps	9 Mbps	12 Mbps	18 Mbps	24 Mbps	36 Mbps	48 Mbps	54 Mbps
CH 01	2412MHz	21.54	21.56	21.74	21.95	24.05	23.69	24.00	23.97
CH 06	2437MHz	23.07	23.16	23.26	23.82	24.40	24.38	24.34	24.31
CH 11	2462MHz	20.29	20.38	20.58	20.70	23.17	23.14	23.12	23.15

Channel	Frequency	2.4GHz 802.11g Average Power (dBm)							
		OFDM Data Rate							
		6 Mbps	9 Mbps	12 Mbps	18 Mbps	24 Mbps	36 Mbps	48 Mbps	54 Mbps
CH 01	2412MHz	15.35	15.27	15.22	15.45	15.61	15.57	15.60	15.60
CH 06	2437MHz	17.80	17.69	17.66	17.77	17.79	17.25	16.29	16.16
CH 11	2462MHz	14.23	14.17	14.15	14.35	14.70	14.67	14.56	14.65



Channel	Frequency	2.4GHz 802.11n HT20 RF Power (dBm)							
		OFDM Data Rate							
		MCS0	MCS1	MCS2	MCS3	MCS4	MCS5	MCS6	MCS7
CH 01	2412MHz	20.90	21.14	20.97	23.62	23.60	23.56	23.61	23.10
CH 06	2437MHz	23.10	23.24	23.17	24.09	24.08	24.07	24.05	24.07
CH 11	2462MHz	19.41	19.75	19.55	22.56	22.05	22.08	22.55	22.55

Channel	Frequency	2.4GHz 802.11n HT20 Average Power (dBm)							
		OFDM Data Rate							
		MCS0	MCS1	MCS2	MCS3	MCS4	MCS5	MCS6	MCS7
CH 01	2412MHz	14.23	14.04	14.11	14.82	14.79	14.80	14.70	14.80
CH 06	2437MHz	17.58	17.49	17.60	16.27	16.26	16.26	16.25	15.41
CH 11	2462MHz	12.59	12.43	12.53	13.28	13.26	13.25	13.27	13.01

Channel	Frequency	2.4GHz 802.11n VHT20 RF Power (dBm)								
		OFDM Data Rate								
		MCS0	MCS1	MCS2	MCS3	MCS4	MCS5	MCS6	MCS7	MCS8
CH 01	2412MHz	23.17	23.15	23.14	24.09	24.03	23.99	24.08	23.84	23.99
CH 06	2437MHz	23.16	23.28	23.25	24.08	24.07	24.06	24.07	24.05	24.03
CH 11	2462MHz	20.55	20.54	20.44	23.35	23.29	23.23	23.33	22.77	19.17

Channel	Frequency	2.4GHz 802.11n VHT20 Average Power (dBm)								
		OFDM Data Rate								
		MCS0	MCS1	MCS2	MCS3	MCS4	MCS5	MCS6	MCS7	MCS8
CH 01	2412MHz	17.76	17.58	17.68	16.41	16.29	16.38	16.38	15.39	15.34
CH 06	2437MHz	17.67	17.60	17.57	16.38	16.33	16.30	16.28	15.44	14.40
CH 11	2462MHz	14.15	13.98	14.11	14.90	14.71	14.86	14.88	14.29	13.86



MIMO <Ant. 1+2>

Channel	Frequency	2.4GHz 802.11b RF Power (dBm)			
		DSSS Data Rate			
		1 Mbps	2 Mbps	5.5 Mbps	11 Mbps
CH 01	2412MHz	24.45	24.20	24.19	24.18
CH 06	2437MHz	24.40	23.99	24.10	24.02
CH 11	2462MHz	23.41	23.37	23.33	23.33

Channel	Frequency	2.4GHz 802.11b Average Power (dBm)			
		DSSS Data Rate			
		1 Mbps	2 Mbps	5.5 Mbps	11 Mbps
CH 01	2412MHz	22.12	22.10	22.11	22.09
CH 06	2437MHz	21.85	21.67	21.93	21.80
CH 11	2462MHz	21.22	21.12	21.24	20.76

Channel	Frequency	2.4GHz 802.11g RF Power (dBm)							
		OFDM Data Rate							
		6 Mbps	9 Mbps	12 Mbps	18 Mbps	24 Mbps	36 Mbps	48 Mbps	54 Mbps
CH 01	2412MHz	24.19	24.33	24.42	24.71	26.99	26.96	26.95	26.96
CH 06	2437MHz	25.83	25.84	26.00	26.53	27.49	27.29	27.18	27.17
CH 11	2462MHz	22.92	23.07	23.27	23.34	25.90	25.88	25.88	25.79

Channel	Frequency	2.4GHz 802.11g Average Power (dBm)							
		OFDM Data Rate							
		6 Mbps	9 Mbps	12 Mbps	18 Mbps	24 Mbps	36 Mbps	48 Mbps	54 Mbps
CH 01	2412MHz	18.04	18.04	18.01	18.15	18.31	18.27	18.20	18.29
CH 06	2437MHz	20.46	20.37	20.34	20.47	20.48	19.95	19.03	18.98
CH 11	2462MHz	16.99	16.90	16.89	17.14	17.29	17.28	17.28	17.09



Channel	Frequency	2.4GHz 802.11n HT20 RF Power (dBm)							
		OFDM Data Rate							
		MCS0	MCS1	MCS2	MCS3	MCS4	MCS5	MCS6	MCS7
CH 01	2412MHz	23.60	23.66	23.63	26.65	26.49	26.47	26.62	26.63
CH 06	2437MHz	26.02	25.90	25.91	27.22	27.21	27.18	27.16	26.91
CH 11	2462MHz	21.82	21.83	21.91	24.96	24.90	24.84	24.72	24.94

Channel	Frequency	2.4GHz 802.11n HT20 Average Power (dBm)							
		OFDM Data Rate							
		MCS0	MCS1	MCS2	MCS3	MCS4	MCS5	MCS6	MCS7
CH 01	2412MHz	16.92	17.03	17.00	17.64	17.63	17.63	17.62	17.60
CH 06	2437MHz	20.44	20.43	20.34	19.19	19.13	19.15	19.14	18.11
CH 11	2462MHz	15.35	15.44	15.45	16.20	16.18	16.18	16.18	16.19

Channel	Frequency	2.4GHz 802.11n VHT20 RF Power (dBm)								
		OFDM Data Rate								
		MCS0	MCS1	MCS2	MCS3	MCS4	MCS5	MCS6	MCS7	MCS8
CH 01	2412MHz	25.98	25.97	25.95	27.03	26.97	26.95	26.96	26.81	26.82
CH 06	2437MHz	25.91	26.00	25.91	27.01	27.00	26.98	27.00	26.86	26.71
CH 11	2462MHz	23.20	23.25	23.13	26.06	26.03	25.99	26.04	25.56	25.53

Channel	Frequency	2.4GHz 802.11n VHT20 Average Power (dBm)								
		OFDM Data Rate								
		MCS0	MCS1	MCS2	MCS3	MCS4	MCS5	MCS6	MCS7	MCS8
CH 01	2412MHz	20.50	20.36	20.44	19.09	19.04	18.98	18.99	18.09	18.26
CH 06	2437MHz	20.34	20.18	20.31	18.99	18.98	18.98	18.95	18.10	17.08
CH 11	2462MHz	16.89	16.70	16.86	17.67	17.63	17.57	17.53	16.94	15.99

Note: MIMO Ant. 1+2 is a calculated result from sum of the power MIMO Ant. 1 and MIMO Ant. 2.



2.3 Test Mode

Final test mode of conducted test items and radiated spurious emissions are considering the modulation and worse data rates from the power table described in section 2.2.

Single Antenna

Modulation	Data Rate
802.11b	1 Mbps
802.11g	24 Mbps
802.11n HT20	MCS3
802.11ac VHT20	MCS3

MIMO Antenna

Modulation	Data Rate
802.11b	1 Mbps
802.11g	24 Mbps
802.11n HT20	MCS3
802.11ac VHT20	MCS3

Test Cases	
AC Conducted Emission	Mode 1 :GSM850 Idle + Bluetooth Link + WLAN Link + MP3 + Earphone + USB Cable (Charging from Adapter 1) Mode 2 GSM850 Idle + Bluetooth Link + WLAN Link + MP3 + Earphone + USB Cable (Charging from Adapter 2) Mode 3 GSM850 Idle + Bluetooth Link + WLAN Link + MP3 + Earphone + USB Cable (Charging from Adapter 3)
Remark: The worst case of conducted emission is mode 3; only the test data of it was reported.	

2.4 Connection Diagram of Test System

<WLAN Tx Mode>

<for Adapter 1>

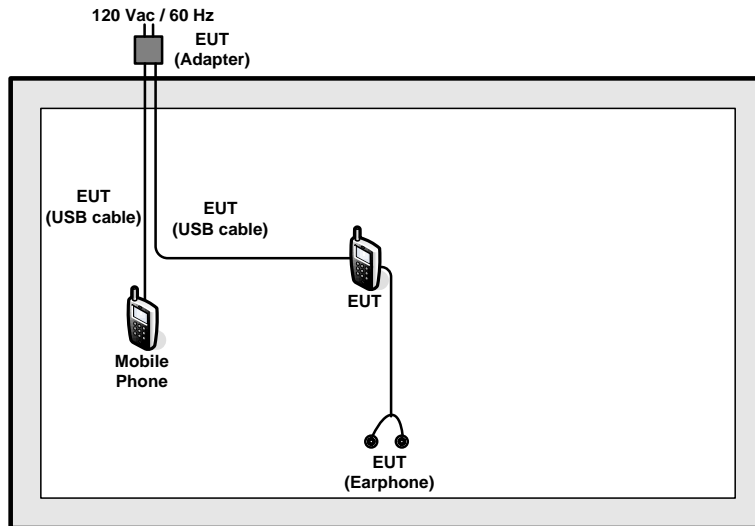

<for Adapter 2>

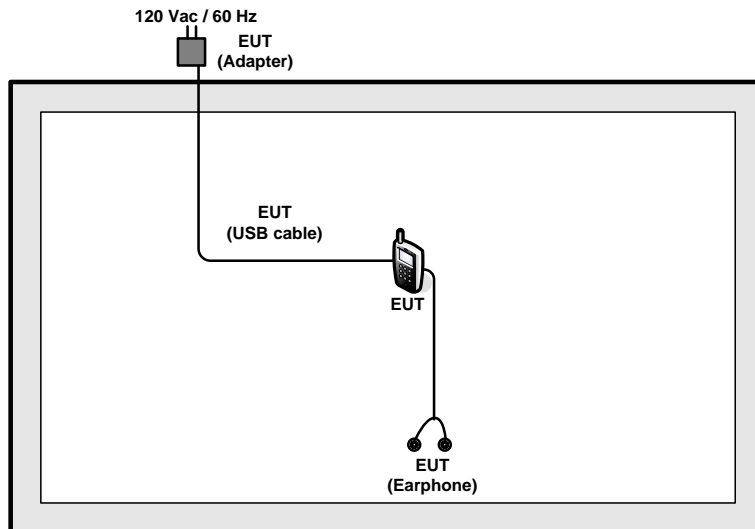

<for Adapter 3>

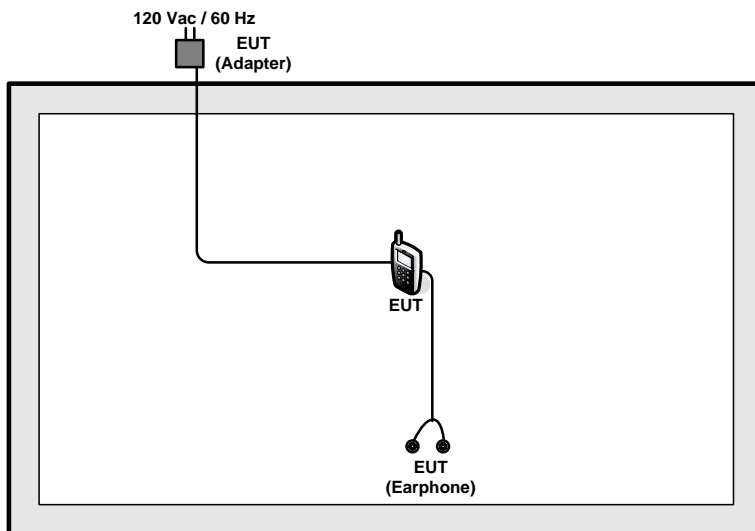

<AC Conducted Emission Mode>

<for Adapter 1>

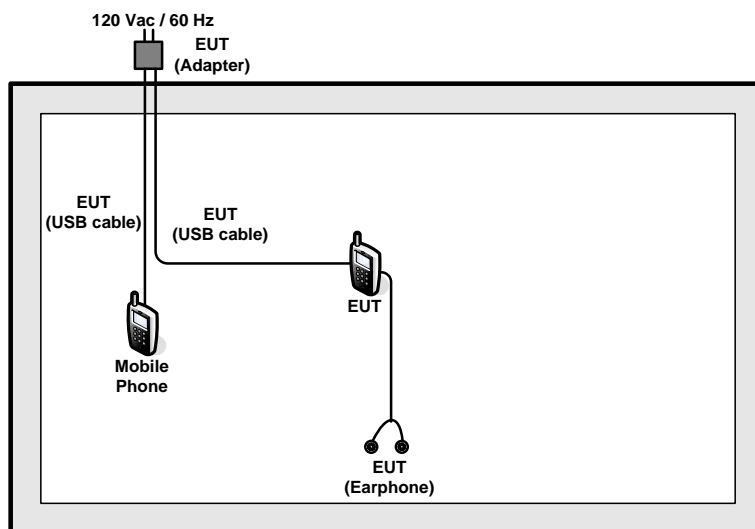

<for Adapter 2>

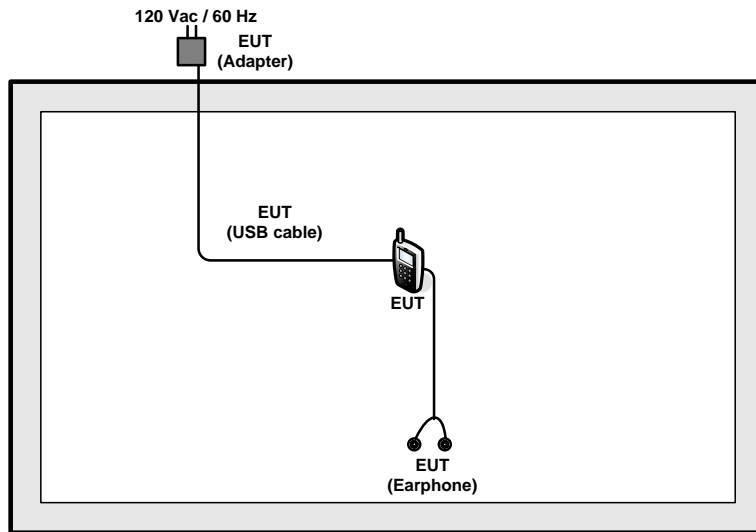

<for Adapter 3>

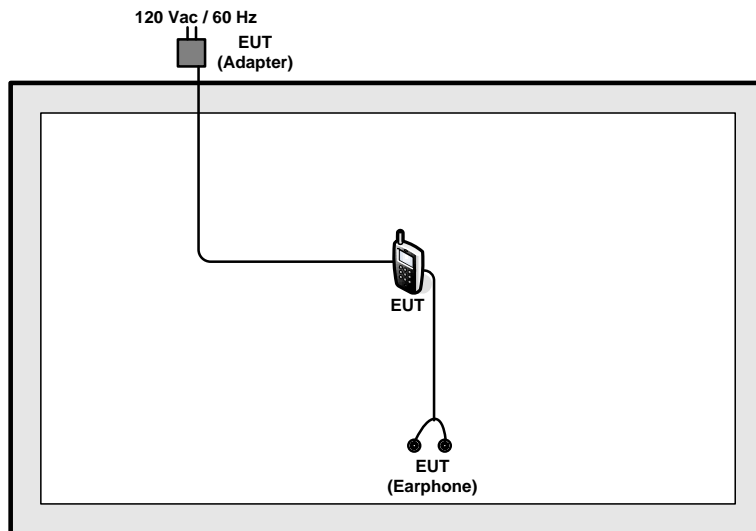



2.5 Support Unit used in test configuration and system

Item	Equipment	Trade Name	Model Name	FCC ID	Data Cable	Power Cord
1.	System Simulator	Anritsu	MT8820C	N/A	N/A	Unshielded, 1.8 m
2.	Bluetooth Earphone	Sony Ericsson	MW600	PY7DDA-2029	N/A	N/A
3.	WLAN AP	D-Link	DIR-865L	KA2IR865LA1	N/A	Unshielded, 1.8 m
4.	Notebook	DELL	Latitude E6320	FCC DoC/ Contains FCC ID: QDS-BRCM1054	N/A	AC I/P: Unshielded, 1.2 m DC O/P: Shielded, 1.8 m
5.	Mobile Cellular Phone	Motorola Mobility, LLC	5137	IHDT56UC2	N/A	N/A
6.	SD Card	SanDisk	MicroSD HC	FCC DoC	N/A	N/A

2.6 EUT Operation Test Setup

For WLAN function, programmed RF utility, “QRCT” installed in the notebook make the EUT provide functions like channel selection and power level for continuous transmitting and receiving signals.

2.7 Measurement Results Explanation Example

For all conducted test items:

The offset level is set in the spectrum analyzer to compensate the RF cable loss and attenuator factor between EUT conducted output port and spectrum analyzer. With the offset compensation, the spectrum analyzer reading level is exactly the EUT RF output level.

Example:

The spectrum analyzer offset is derived from RF cable loss and attenuator factor.

Offset = RF cable loss + attenuator factor.

Following shows an offset computation example with cable loss 4.2 dB and 10dB attenuator.

$$\begin{aligned} \text{Offset(dB)} &= \text{RF cable loss(dB)} + \text{attenuator factor(dB)}. \\ &= 4.2 + 10 = 14.2 \text{ (dB)} \end{aligned}$$

3 Test Result

3.1 6dB Bandwidth Measurement

3.1.1 Limit of 6dB Bandwidth

The minimum 6 dB bandwidth shall be at least 500 kHz.

3.1.2 Measuring Instruments

The measuring equipment is listed in the section 4 of this test report.

3.1.3 Test Procedures

1. The testing follows FCC KDB Publication No. 558074 DTS D01 Meas. Guidance v03r02.
2. The RF output of EUT was connected to the spectrum analyzer by RF cable and attenuator. The path loss was compensated to the results for each measurement.
3. Set to the maximum power setting and enable the EUT transmit continuously.
4. Make the measurement with the spectrum analyzer's resolution bandwidth (RBW) = 100 kHz. Set the Video bandwidth (VBW) = 300 kHz. In order to make an accurate measurement. The 6 dB bandwidth must be greater than 500 kHz.
5. Measure and record the results in the test report.

3.1.4 Test Setup

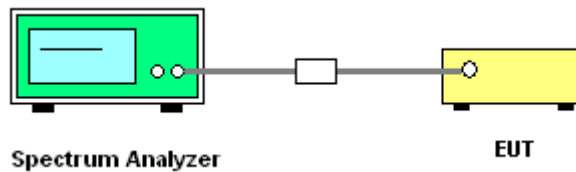



3.1.5 Test Result of 6dB and 99% Occupied Bandwidth

Please refer to Appendix A of this report.

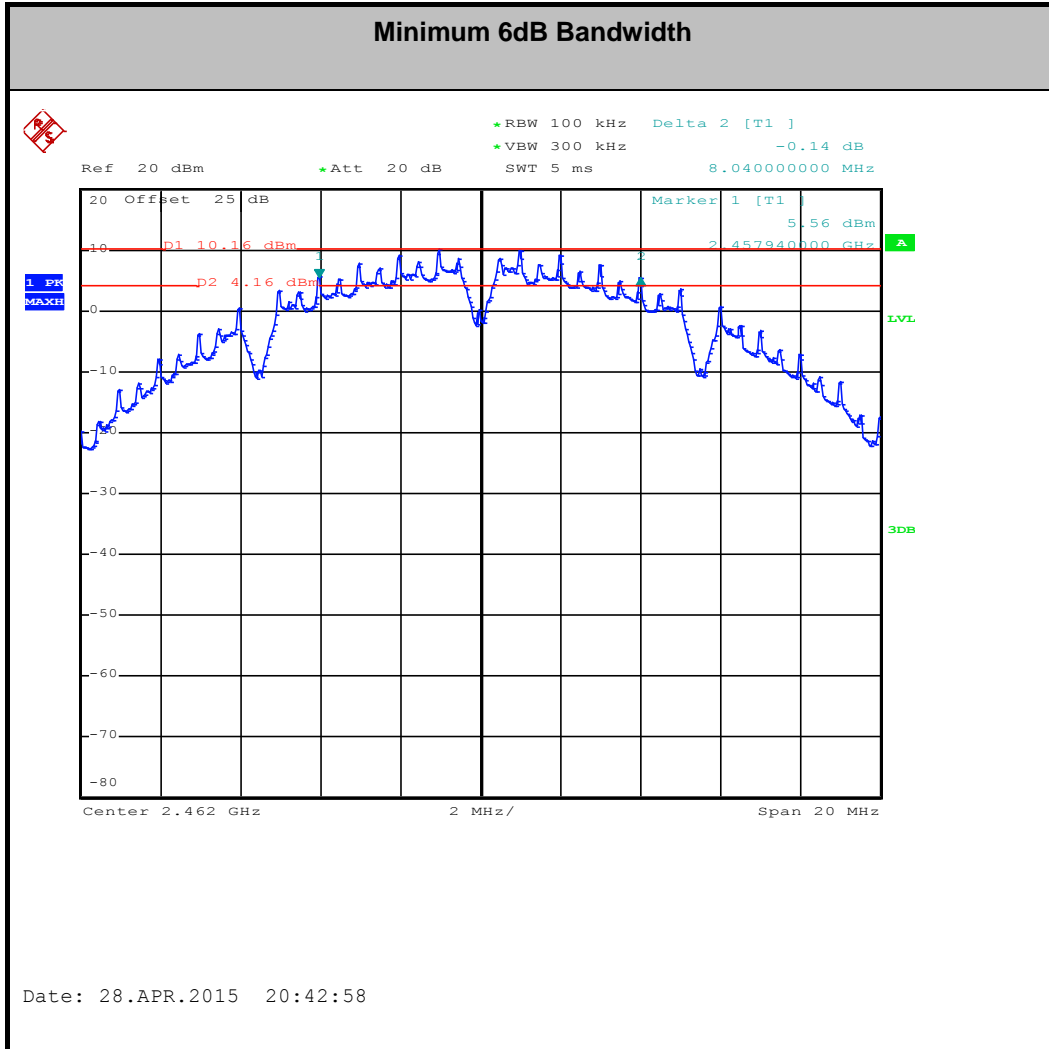

Note : The occupied channel bandwidth is maintained within the band of operation for all of the modulations.

3.2 Peak Output Power Measurement

3.2.1 Limit of Peak Output Power

For systems using digital modulation in the 2400-2483.5MHz, the limit for peak output power is 30dBm. If transmitting antenna with directional gain greater than 6dBi is used, the peak output power from the intentional radiator shall be reduced below the above stated value by the amount in dB that the directional gain of the antenna exceeds 6 dBi. In case of point-to-point operation, the limit has to be reduced by 1dB for every 3dB that the directional gain of the antenna exceeds 6dBi.

3.2.2 Measuring Instruments

The measuring equipment is listed in the section 4 of this test report.

3.2.3 Test Procedures

1. The testing follows the Measurement Procedure of FCC KDB No. 558074 DTS D01 Meas. Guidance v03r02.
2. The RF output of EUT was connected to the power meter by RF cable and attenuator. The path loss was compensated to the results for each measurement.
3. Set to the maximum power setting and enable the EUT transmit continuously.
4. Measure the conducted output power and record the results in the test report.
5. For MIMO mode, calculation method follows FCC KDB 662911 D01 Multiple Transmitter Output v02r01.

3.2.4 Test Setup

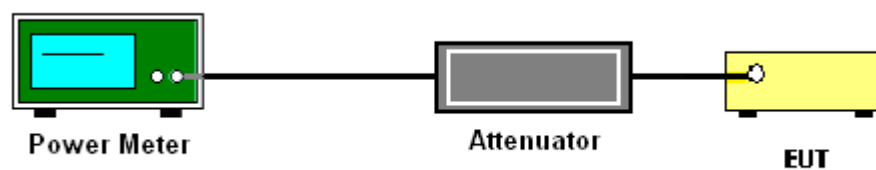



3.2.5 Test Result of Peak Output Power

Please refer to Appendix A of this report.

3.2.6 Test Result of Average output Power (Reporting Only)

Please refer to Appendix A of this report.



3.3 Power Spectral Density Measurement

3.3.1 Limit of Power Spectral Density

The peak power spectral density shall not be greater than 8dBm in any 3kHz band at any time interval of continuous transmission.

3.3.2 Measuring Instruments

The measuring equipment is listed in the section 4 of this test report.

3.3.3 Test Procedures

1. The testing follows Measurement Procedure 10.2 Method PKPSD of FCC KDB Publication No. 558074 D01 DTS Meas. Guidance v03r02
2. The RF output of EUT was connected to the spectrum analyzer by RF cable and attenuator. The path loss was compensated to the results for each measurement.
3. Set to the maximum power setting and enable the EUT transmit continuously.
4. Make the measurement with the spectrum analyzer's resolution bandwidth (RBW) = 3 kHz. Video bandwidth VBW = 10 kHz In order to make an accurate measurement, set the span to 1.5 times DTS Channel Bandwidth. (6dB BW)
5. Detector = peak, Sweep time = auto couple, Trace mode = max hold, Allow trace to fully stabilize. Use the peak marker function to determine the maximum power level.
6. Measure and record the results in the test report.
7. For MIMO mode, calculation method follows FCC KDB 662911 D01 Multiple Transmitter Output v02r01.

If measurements performed using method (2) plus $10 \log(N)$ exceeds the emission limit, the test should choose method (1) before declaring that the device fails the emission limit.

Method (1): Measure and sum the spectra across the outputs.

The total final Power Spectral Density is from a device with 2 transmitter outputs. The spectrum measurements of the individual outputs are all performed with the same span and number of points, the spectrum value in the first spectral bin of output 1 is summed with that in the first spectral bin of output 2 to obtain the value for the first frequency bin of the summed spectrum.

Method (2): Measure and add $10 \log(N)$ dB, where N is the number of outputs. (N=2)

3.4 Conducted Band Edges and Spurious Emission Measurement

3.4.1 Limit of Conducted Band Edges and Spurious Emission Measurement

In any 100 kHz bandwidth outside of the authorized frequency band, the emissions which fall in the non-restricted bands shall be attenuated at least 20 dB / 30dB relative to the maximum PSD level in 100 kHz by RF conducted measurement and radiated emissions which fall in the restricted bands, as defined in Section 15.205(a), must also comply with the radiated emission limits specified in Section 15.209(a).

3.4.2 Measuring Instruments

The measuring equipment is listed in the section 4 of this test report.

3.4.3 Test Procedures

1. The testing follows FCC KDB Publication No. 558074 D01 DTS Meas. Guidance v03r02.
2. The RF output of EUT was connected to the spectrum analyzer by RF cable and attenuator. The path loss was compensated to the results for each measurement.
3. Set to the maximum power setting and enable the EUT transmit continuously.
4. Set RBW = 100 kHz, VBW=300 kHz, Peak Detector. Unwanted Emissions measured in any 100 kHz bandwidth outside of the authorized frequency band shall be attenuated by at least 20 dB relative to the maximum in-band peak PSD level in 100 kHz when maximum peak conducted output power procedure is used. If the transmitter complies with the conducted power limits based on the use of RMS averaging over a time interval, the attenuation required under this paragraph shall be 30 dB instead of 20 dB per 15.247(d).
5. Measure and record the results in the test report.
6. The RF fundamental frequency should be excluded against the limit line in the operating frequency band.

3.4.4 Test Setup

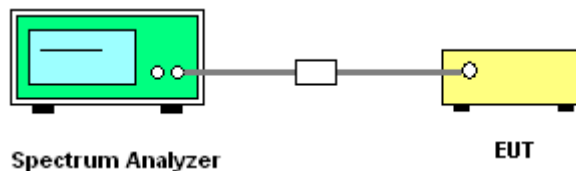



3.4.5 Test Result of Conducted Band Edges and Spurious Emission

Number of TX = 2, Ant. 1 (Measured)

Number of TX	2	Ant. :	1
Test Mode :	802.11b	Temperature :	21~25°C
Test Band :	2.4GHz Low	Relative Humidity :	51~54%
Test Channel :	01	Test Engineer :	Derek Hsu

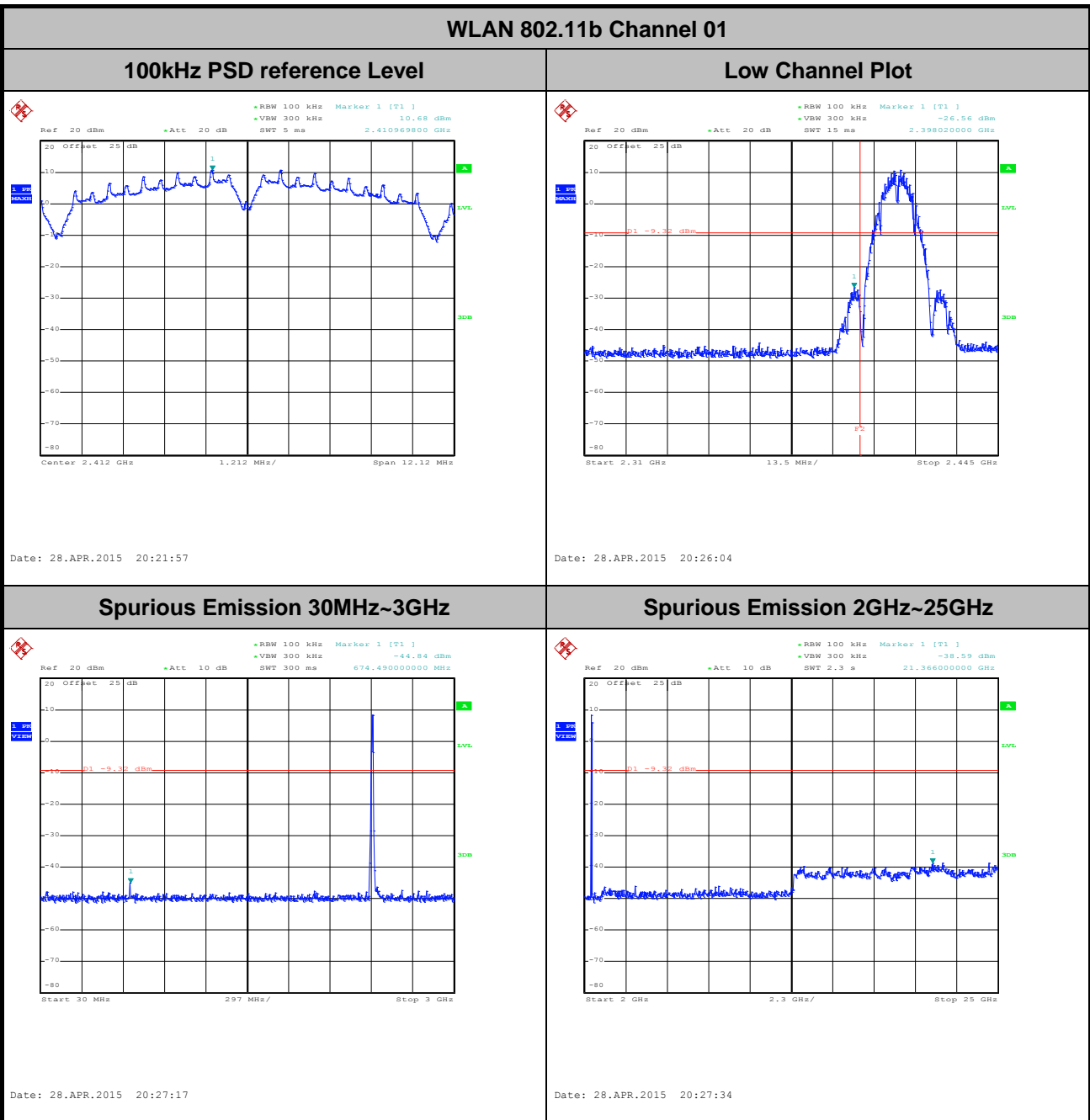



Number of TX :	2	Ant. :	1
Test Mode :	802.11b	Temperature :	21~25°C
Test Band :	2.4GHz Mid	Relative Humidity :	51~54%
Test Channel :	06	Test Engineer :	Derek Hsu

WLAN 802.11b Channel 06

100kHz PSD reference Level

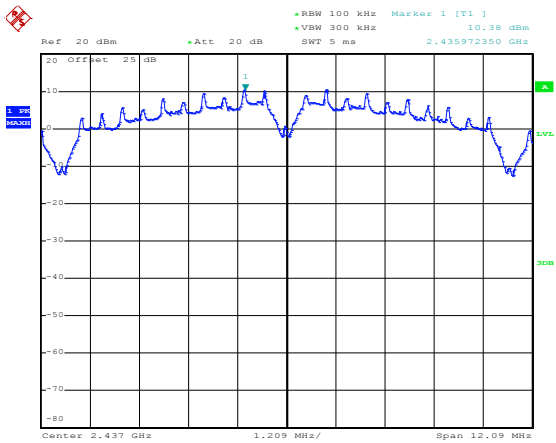

Date: 28.APR.2015 20:36:13

Spurious Emission 30MHz~3GHz

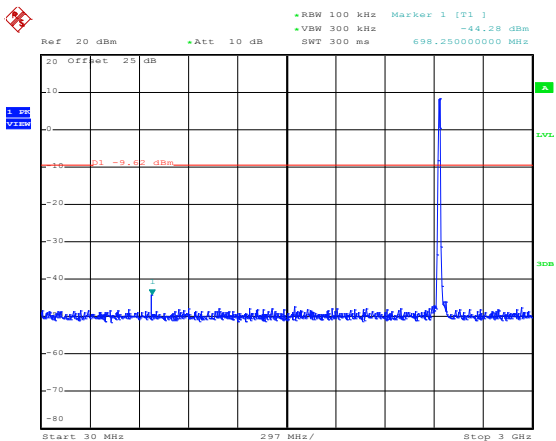

Date: 28.APR.2015 20:36:45

Spurious Emission 2GHz~25GHz

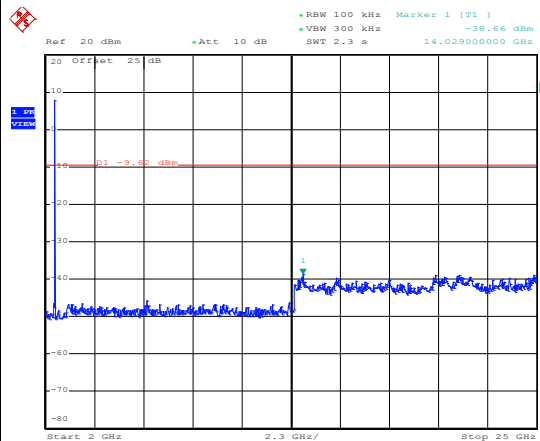

Date: 28.APR.2015 20:37:03



Number of TX :	2	Ant. :	1
Test Mode :	802.11b	Temperature :	21~25°C
Test Band :	2.4GHz High	Relative Humidity :	51~54%
Test Channel :	11	Test Engineer :	Derek Hsu

WLAN 802.11b Channel 11

100kHz PSD reference Level

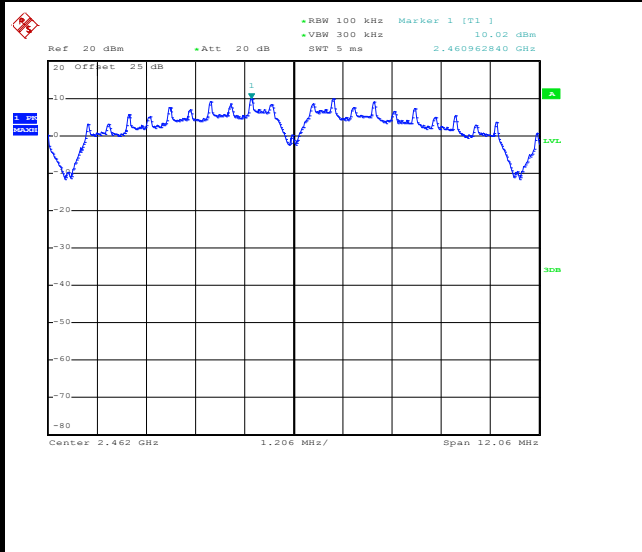

High Channel Plot

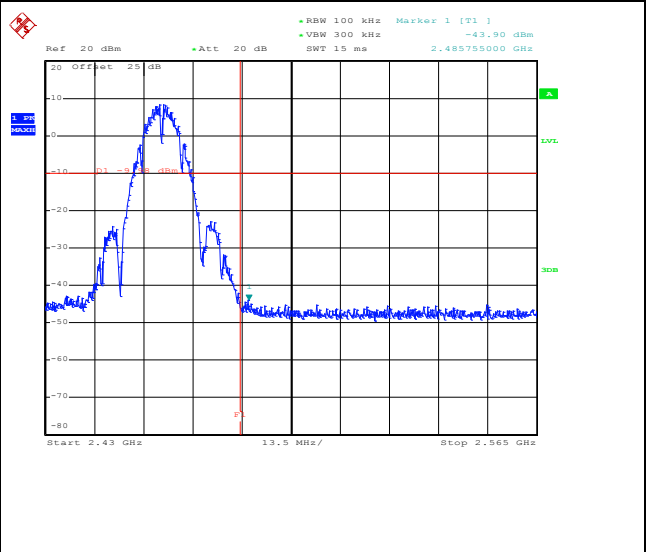

Spurious Emission 30MHz~3GHz

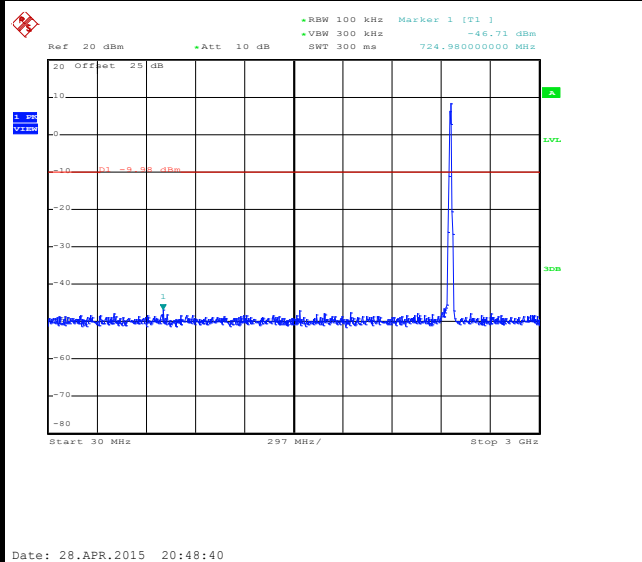

Spurious Emission 2GHz~25GHz

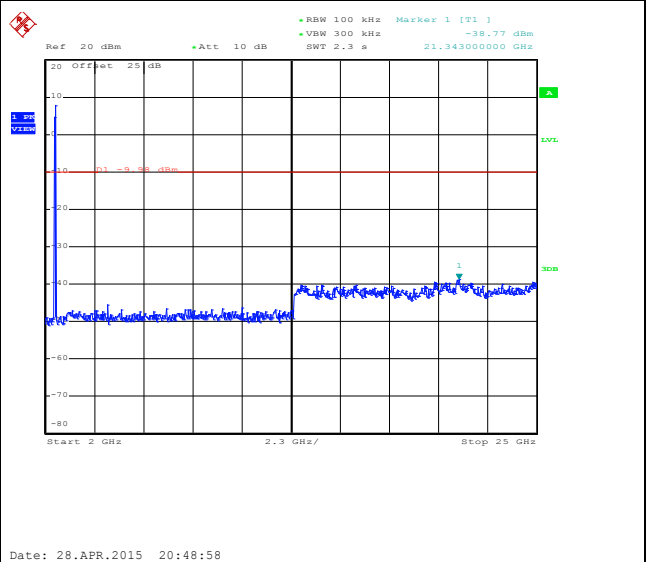



Number of TX :	2	Ant. :	1
Test Mode :	802.11g	Temperature :	21~25°C
Test Band :	2.4GHz Low	Relative Humidity :	51~54%
Test Channel :	01	Test Engineer :	Derek Hsu

WLAN 802.11g Channel 01

100kHz PSD reference Level

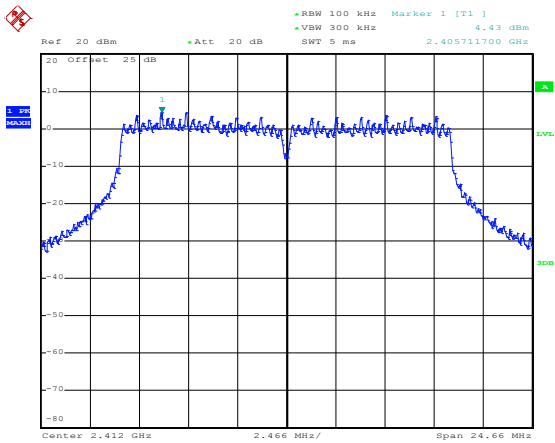

Date: 29.APR.2015 22:14:26

Low Channel Plot

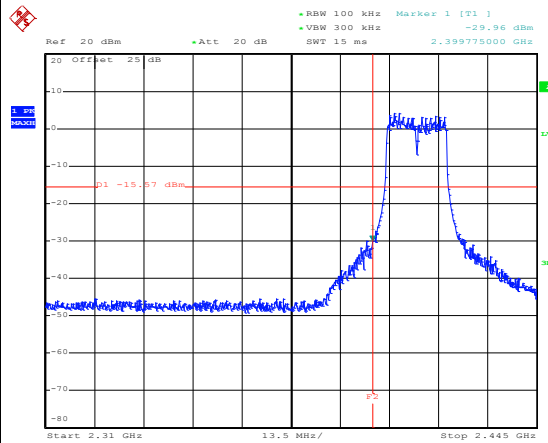

Date: 29.APR.2015 22:15:53

Spurious Emission 30MHz~3GHz

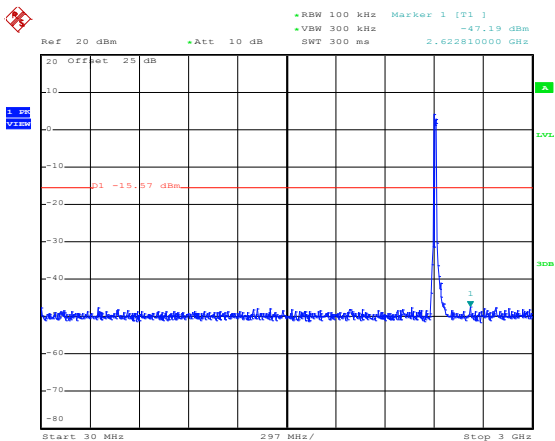

Date: 29.APR.2015 22:16:16

Spurious Emission 2GHz~25GHz

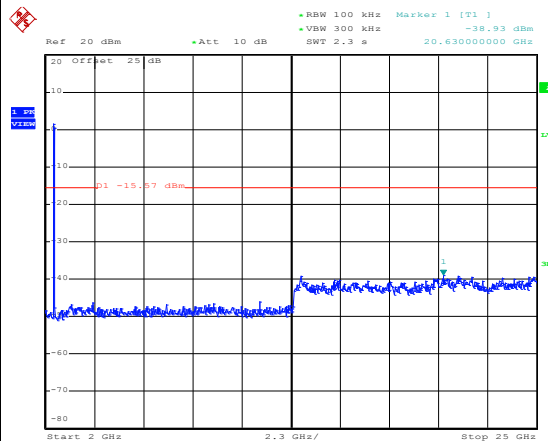

Date: 29.APR.2015 22:16:34



Number of TX :	2	Ant. :	1
Test Mode :	802.11g	Temperature :	21~25°C
Test Band :	2.4GHz Mid	Relative Humidity :	51~54%
Test Channel :	06	Test Engineer :	Derek Hsu

WLAN 802.11g Channel 06

100kHz PSD reference Level

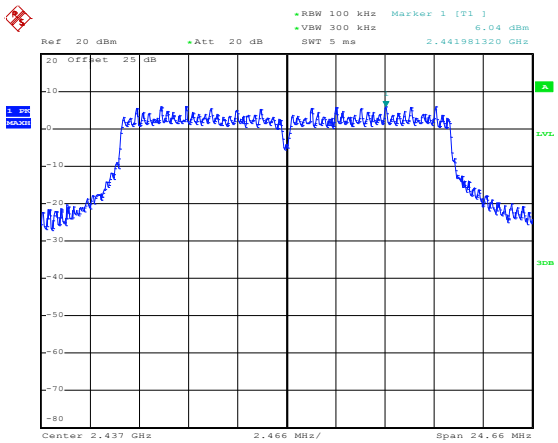

Date: 28.APR.2015 21:07:08

Spurious Emission 30MHz~3GHz

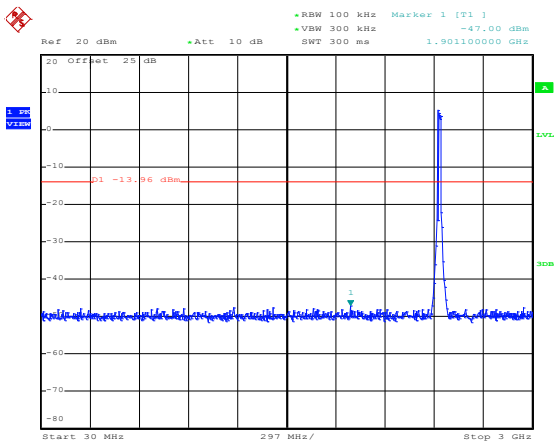

Date: 28.APR.2015 21:07:51

Spurious Emission 2GHz~25GHz

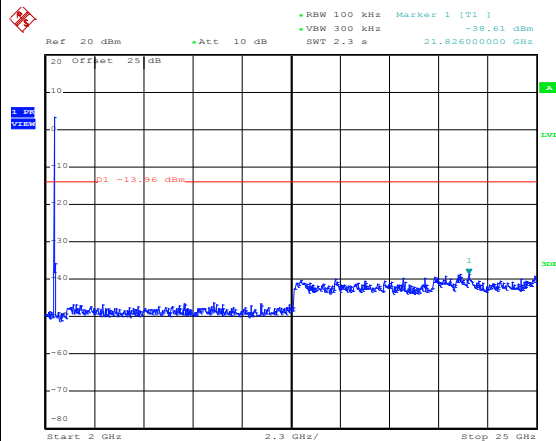

Date: 28.APR.2015 21:08:09



Number of TX :	2	Ant. :	1
Test Mode :	802.11g	Temperature :	21~25°C
Test Band :	2.4GHz High	Relative Humidity :	51~54%
Test Channel :	11	Test Engineer :	Derek Hsu

WLAN 802.11g Channel 11

100kHz PSD reference Level

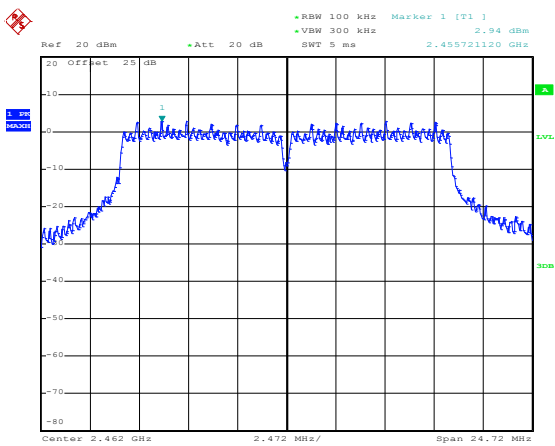

Date: 29.APR.2015 22:25:42

High Channel Plot

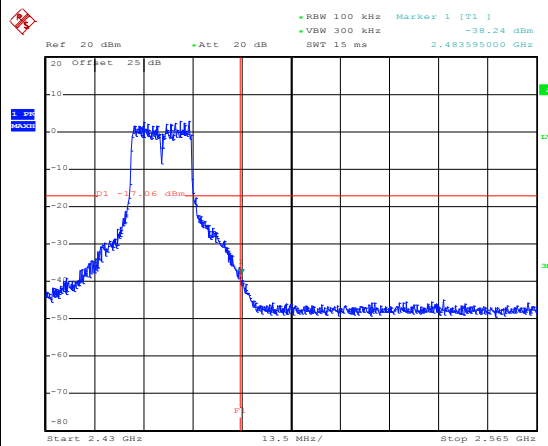

Date: 29.APR.2015 22:25:59

Spurious Emission 30MHz~3GHz

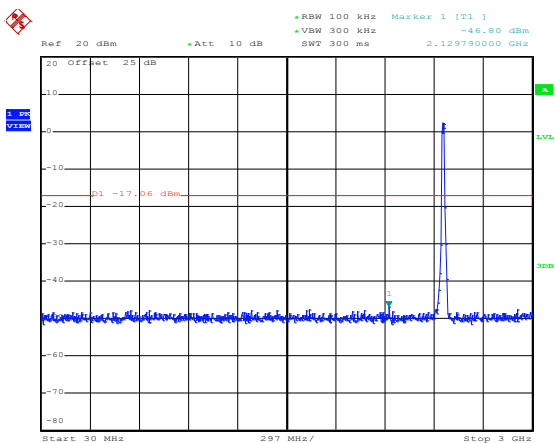

Date: 29.APR.2015 22:26:23

Spurious Emission 2GHz~25GHz

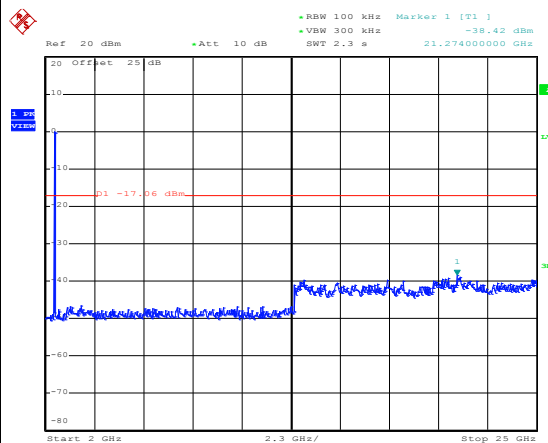

Date: 29.APR.2015 22:26:41



Number of TX :	2	Ant. :	1
Test Mode :	802.11n HT20	Temperature :	21~25°C
Test Band :	2.4GHz Low	Relative Humidity :	51~54%
Test Channel :	01	Test Engineer :	Derek Hsu

WLAN 802.11n HT20 Channel 01

100kHz PSD reference Level

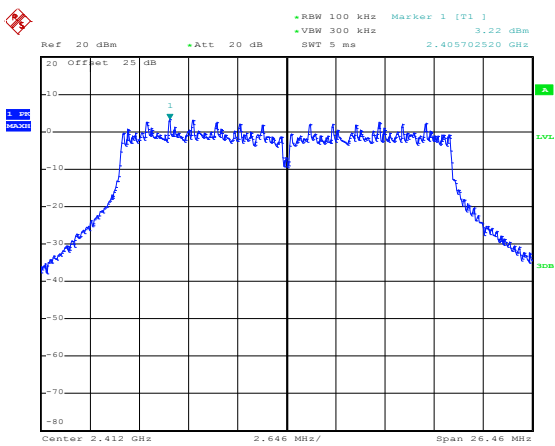

Date: 29.APR.2015 22:38:26

Low Channel Plot

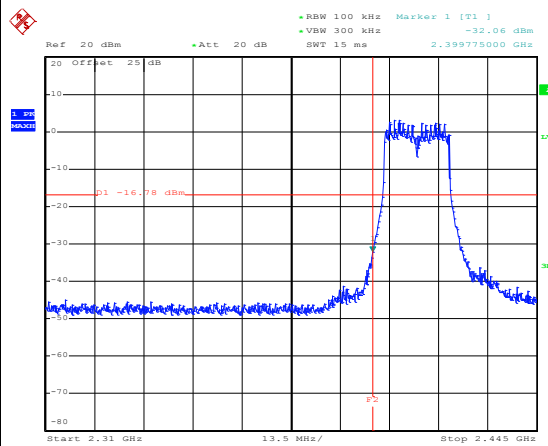

Date: 29.APR.2015 22:38:58

Spurious Emission 30MHz~3GHz

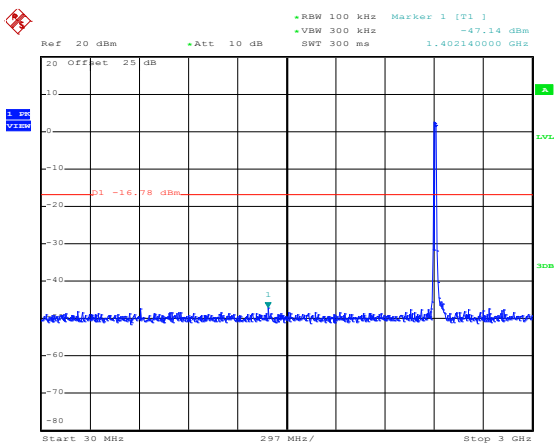

Date: 29.APR.2015 22:39:19

Spurious Emission 2GHz~25GHz

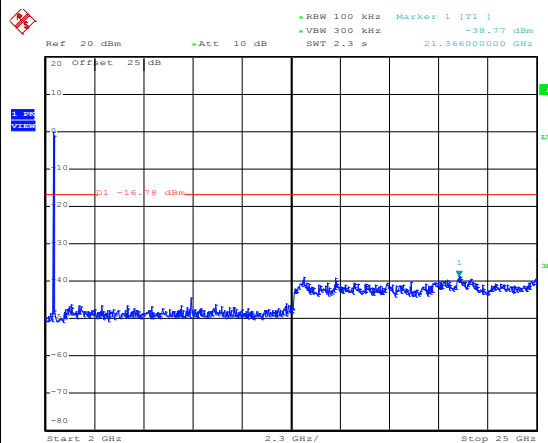

Date: 29.APR.2015 22:39:38



Number of TX :	2	Ant. :	1
Test Mode :	802.11n HT20	Temperature :	21~25°C
Test Band :	2.4GHz Mid	Relative Humidity :	51~54%
Test Channel :	06	Test Engineer :	Derek Hsu

WLAN 802.11n HT20 Channel 06

100kHz PSD reference Level

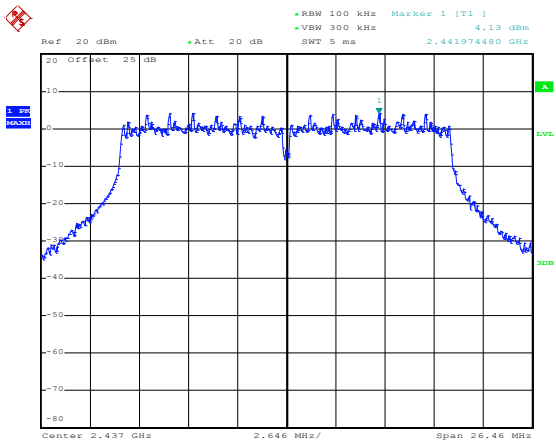

Date: 28.APR.2015 21:46:46

Spurious Emission 30MHz~3GHz

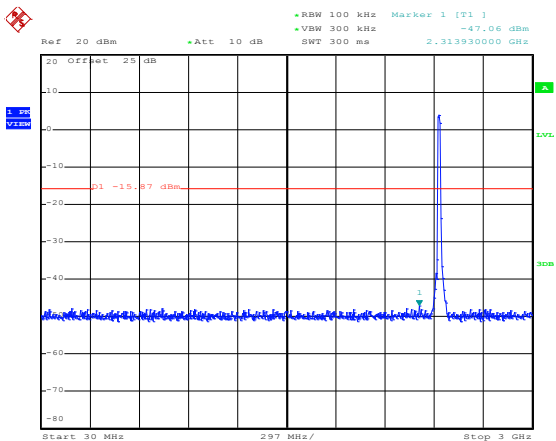

Date: 28.APR.2015 21:47:06

Spurious Emission 2GHz~25GHz

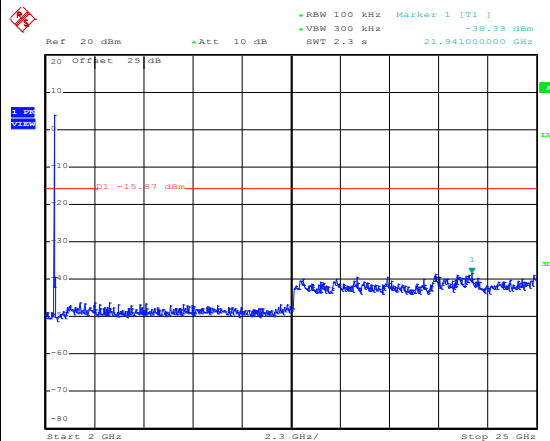

Date: 28.APR.2015 21:47:24



Number of TX :	2	Ant. :	1
Test Mode :	802.11n HT20	Temperature :	21~25°C
Test Band :	2.4GHz High	Relative Humidity :	51~54%
Test Channel :	11	Test Engineer :	Derek Hsu

WLAN 802.11n HT20 Channel 11

100kHz PSD reference Level

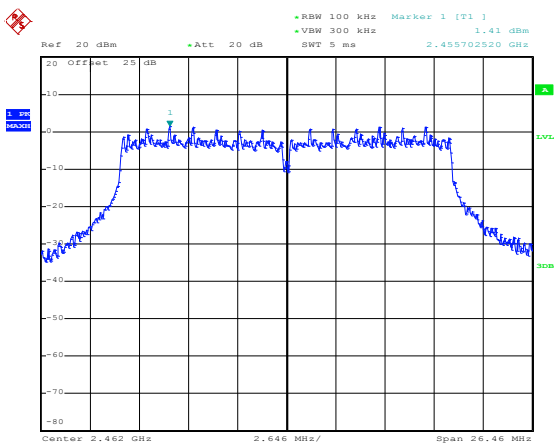

Date: 29.APR.2015 22:46:27

High Channel Plot

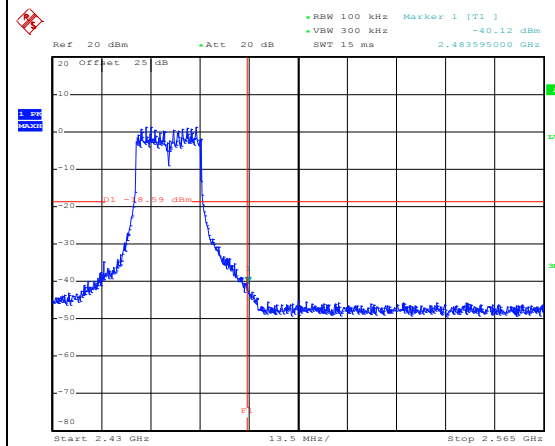

Date: 29.APR.2015 22:47:00

Spurious Emission 30MHz~3GHz

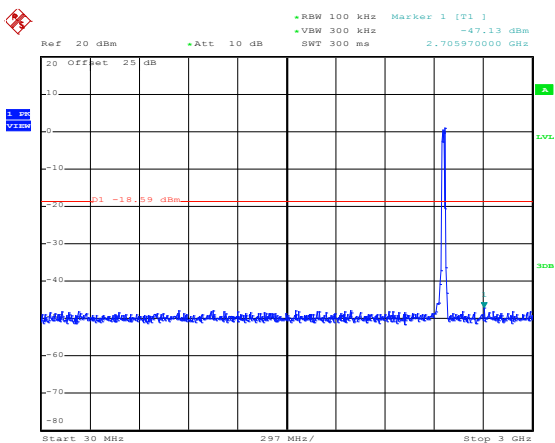

Date: 29.APR.2015 22:47:24

Spurious Emission 2GHz~25GHz

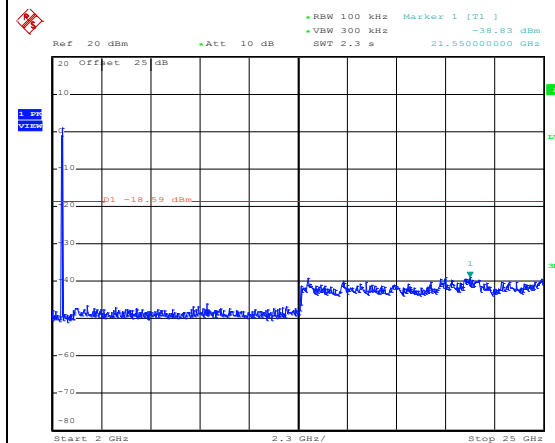

Date: 29.APR.2015 22:47:42



Number of TX :	2	Ant. :	1
Test Mode :	802.11ac VHT20	Temperature :	21~25°C
Test Band :	2.4GHz Low	Relative Humidity :	51~54%
Test Channel :	01	Test Engineer :	Derek Hsu

WLAN 802.11ac VHT20 Channel 01

100kHz PSD reference Level

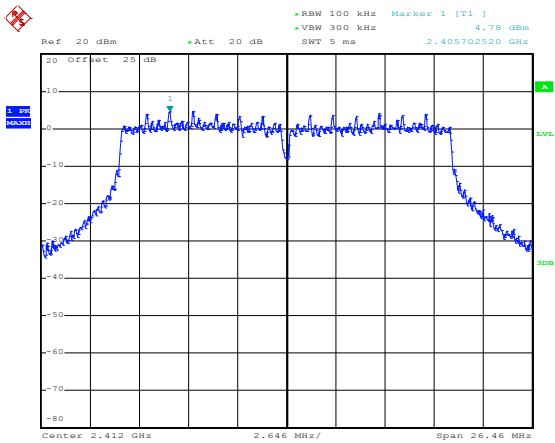

Date: 28.APR.2015 22:15:20

Low Channel Plot

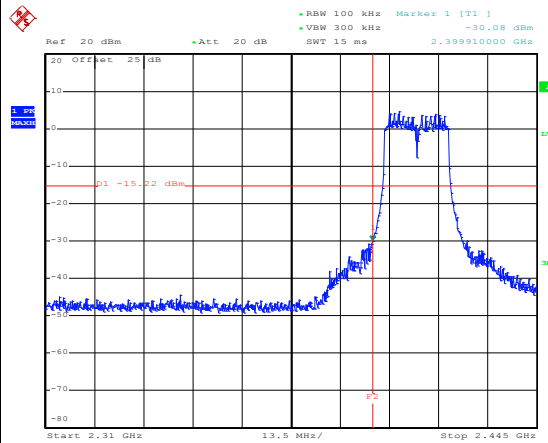

Date: 28.APR.2015 22:15:36

Spurious Emission 30MHz~3GHz

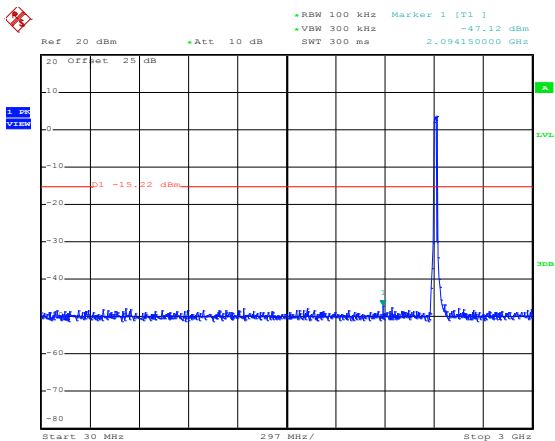

Date: 28.APR.2015 22:15:59

Spurious Emission 2GHz~25GHz

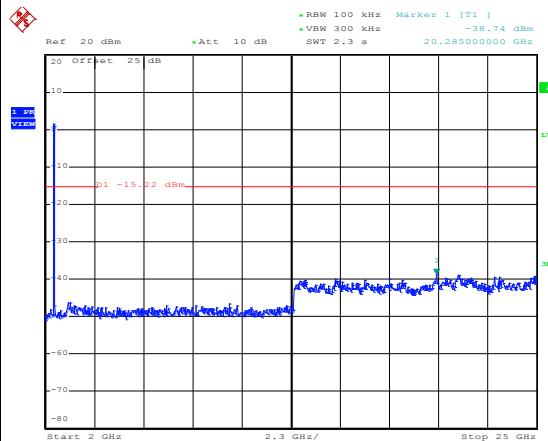

Date: 28.APR.2015 22:16:17



Number of TX :	2	Ant. :	1
Test Mode :	802.11ac VHT20	Temperature :	21~25°C
Test Band :	2.4GHz Mid	Relative Humidity :	51~54%
Test Channel :	06	Test Engineer :	Derek Hsu

WLAN 802.11ac VHT20 Channel 06

100kHz PSD reference Level

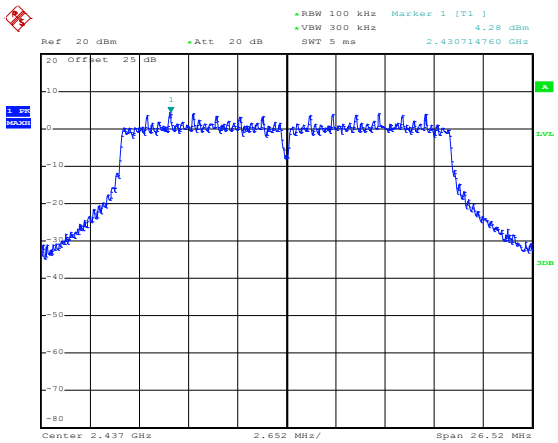

Date: 28.APR.2015 22:31:09

Spurious Emission 30MHz~3GHz

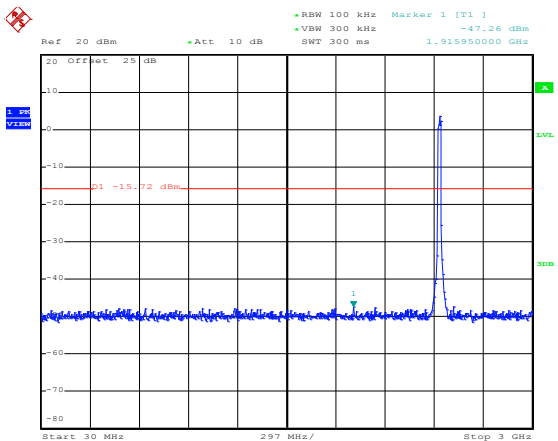

Date: 28.APR.2015 22:31:39

Spurious Emission 2GHz~25GHz

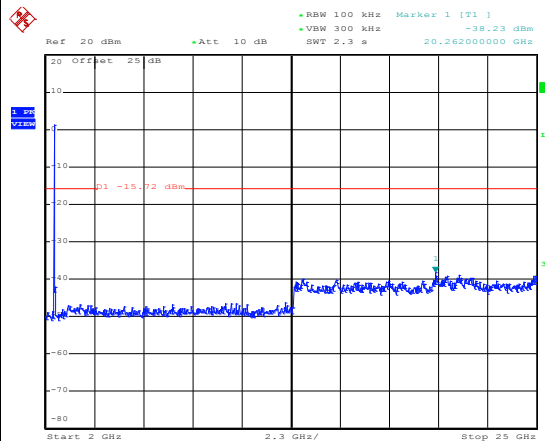

Date: 28.APR.2015 22:31:57



Number of TX :	2	Ant. :	1
Test Mode :	802.11ac VHT20	Temperature :	21~25°C
Test Band :	2.4GHz High	Relative Humidity :	51~54%
Test Channel :	11	Test Engineer :	Derek Hsu

WLAN 802.11ac VHT20 Channel 11

100kHz PSD reference Level

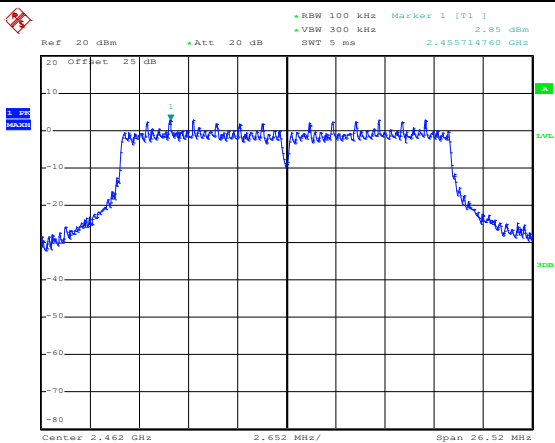

Date: 29.APR.2015 22:58:54

High Channel Plot

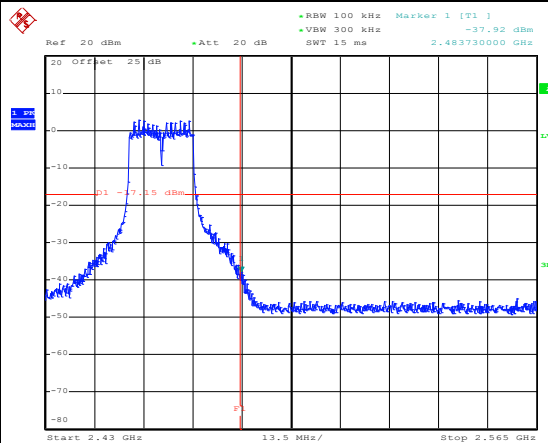

Date: 29.APR.2015 22:59:14

Spurious Emission 30MHz~3GHz

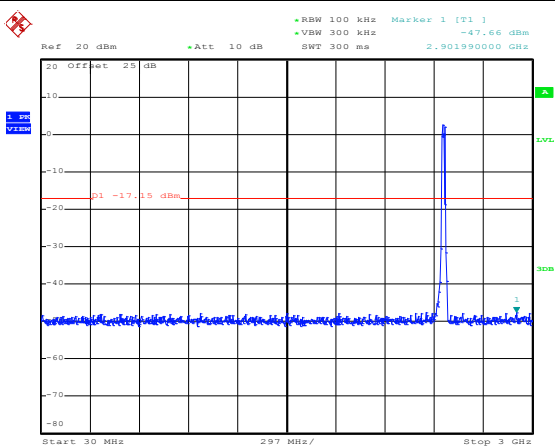

Date: 29.APR.2015 23:00:17

Spurious Emission 2GHz~25GHz

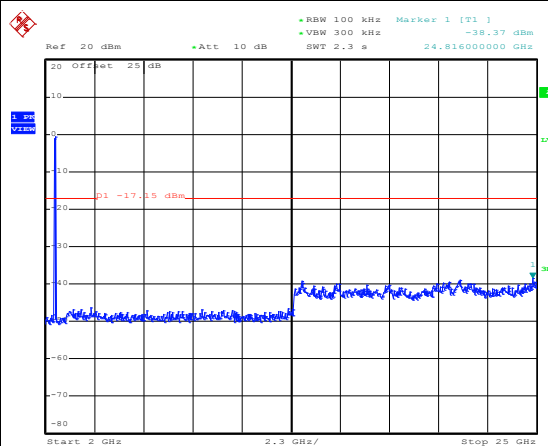

Date: 29.APR.2015 23:00:35



Number of TX = 2, Ant. 2 (Measured)

Number of TX :	2	Ant. :	2
Test Mode :	802.11b	Temperature :	21~25°C
Test Band :	2.4GHz Low	Relative Humidity :	51~54%
Test Channel :	01	Test Engineer :	Derek Hsu

WLAN 802.11b Channel 01

100kHz PSD reference Level

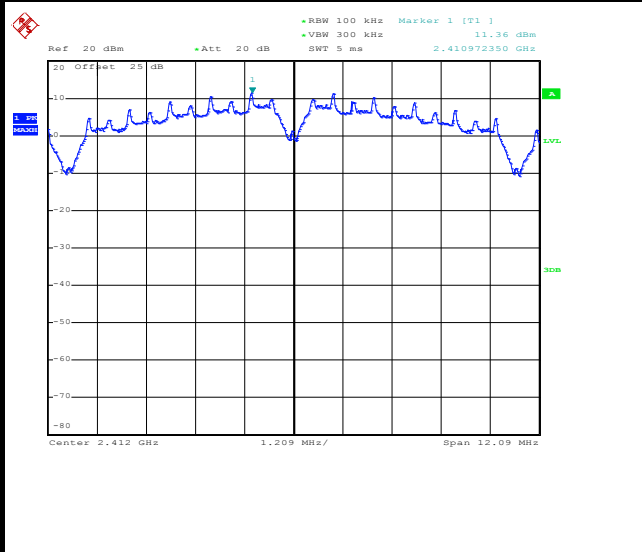

Date: 28.APR.2015 20:31:08

Low Channel Plot

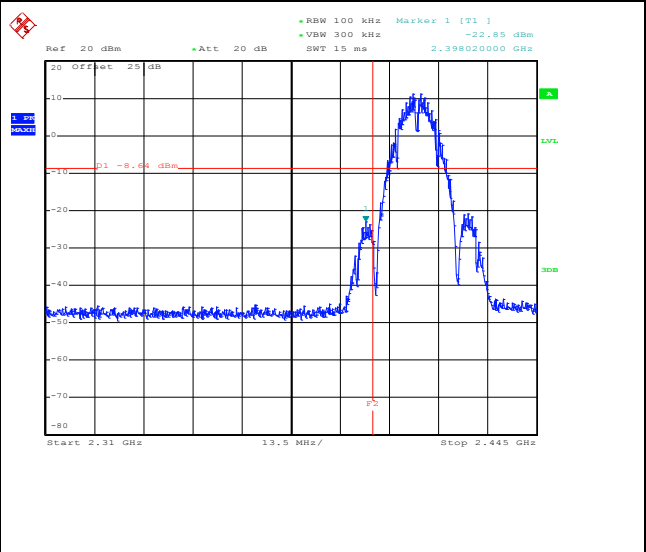

Date: 28.APR.2015 20:31:30

Spurious Emission 30MHz~3GHz

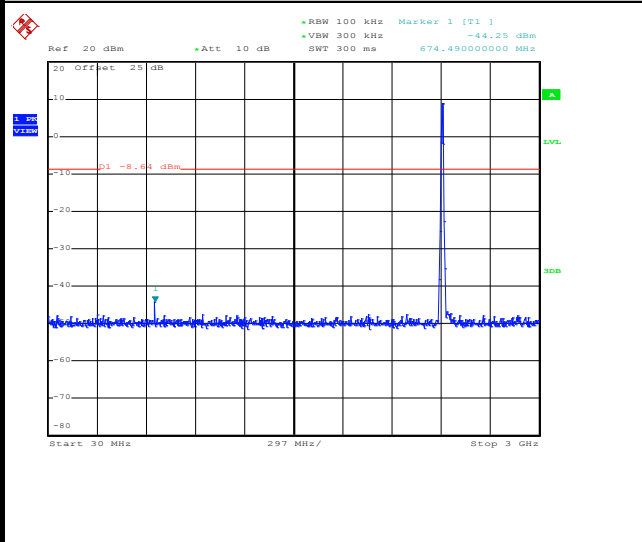

Date: 28.APR.2015 20:32:09

Spurious Emission 2GHz~25GHz

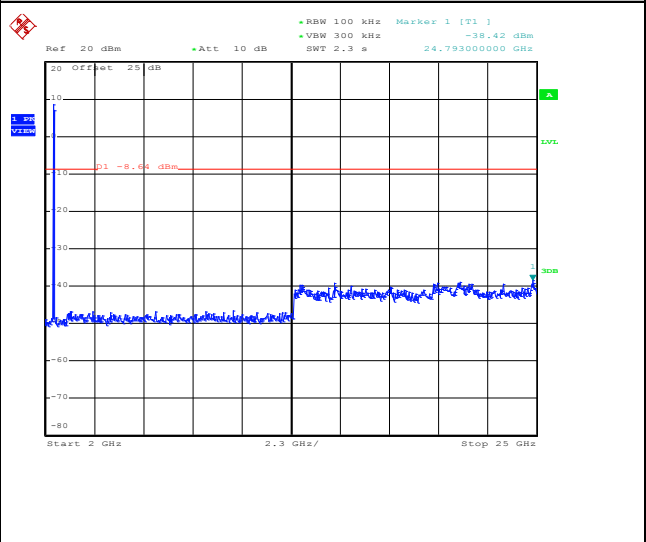

Date: 28.APR.2015 20:32:27



Number of TX :	2	Ant. :	2
Test Mode :	802.11b	Temperature :	21~25°C
Test Band :	2.4GHz Mid	Relative Humidity :	51~54%
Test Channel :	06	Test Engineer :	Derek Hsu

WLAN 802.11b Channel 06

100kHz PSD reference Level

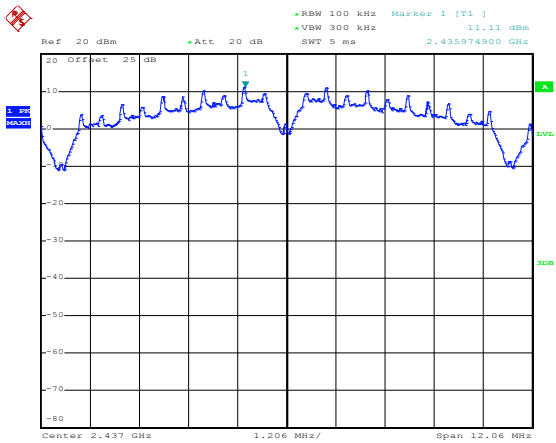

Date: 28.APR.2015 20:40:10

Spurious Emission 30MHz~3GHz

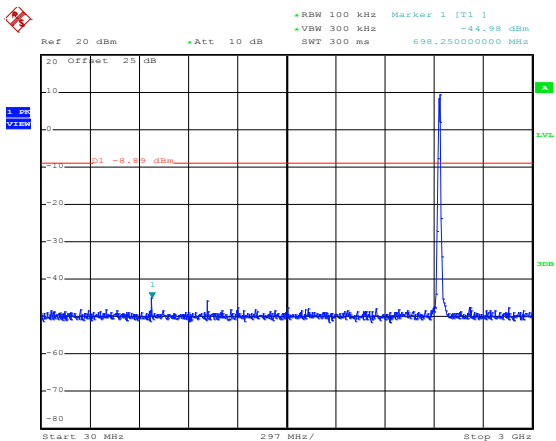

Date: 28.APR.2015 20:41:13

Spurious Emission 2GHz~25GHz

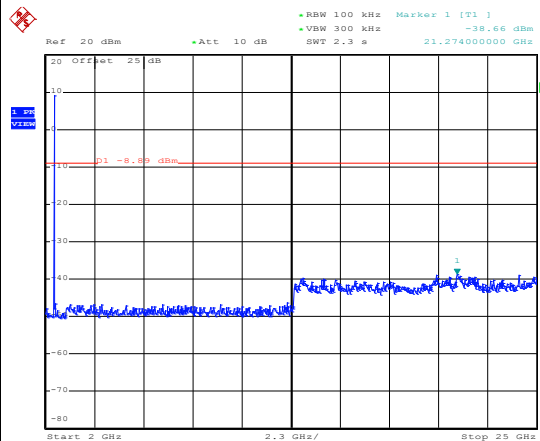

Date: 28.APR.2015 20:41:31



Number of TX :	2	Ant. :	2
Test Mode :	802.11b	Temperature :	21~25°C
Test Band :	2.4GHz High	Relative Humidity :	51~54%
Test Channel :	11	Test Engineer :	Derek Hsu

WLAN 802.11b Channel 11

100kHz PSD reference Level

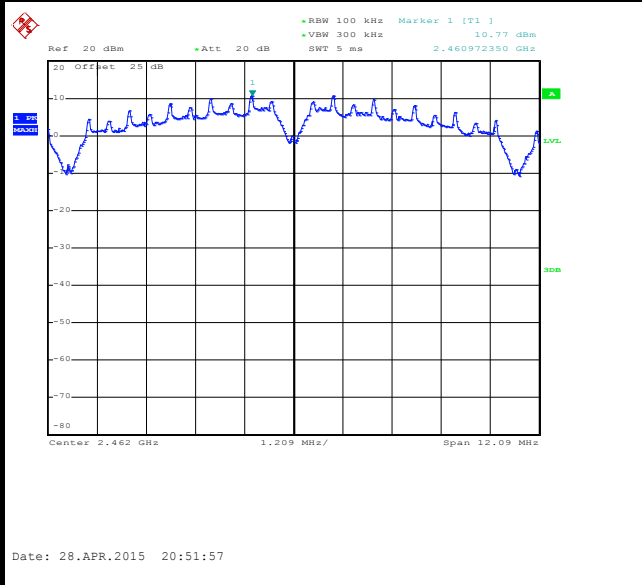

High Channel Plot

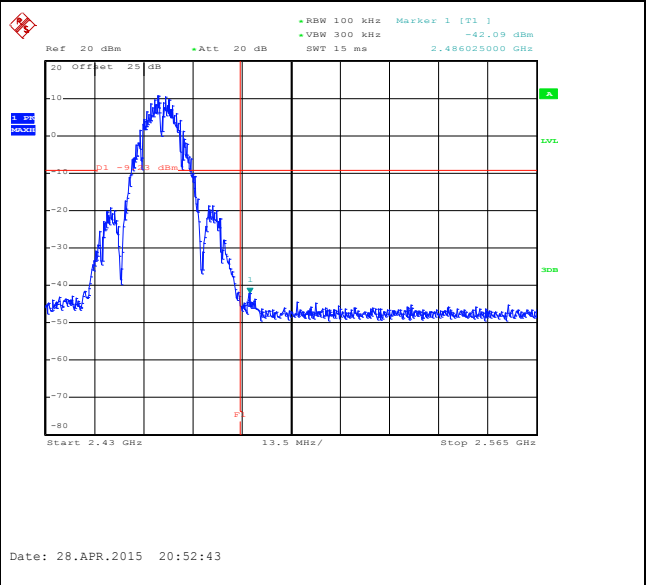

Spurious Emission 30MHz~3GHz

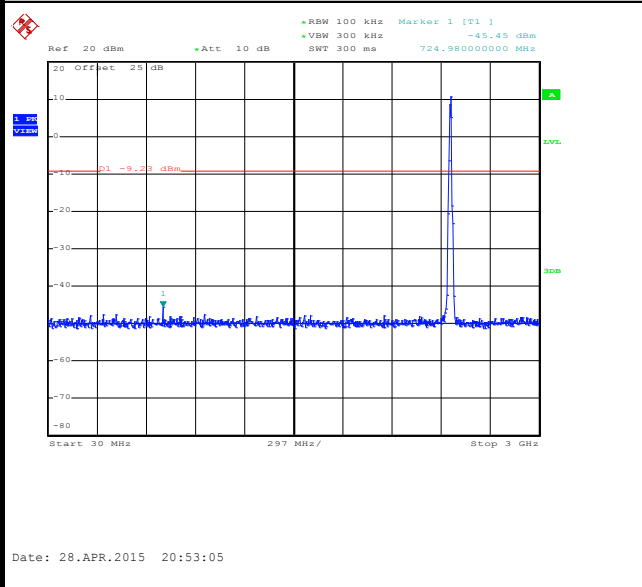

Spurious Emission 2GHz~25GHz

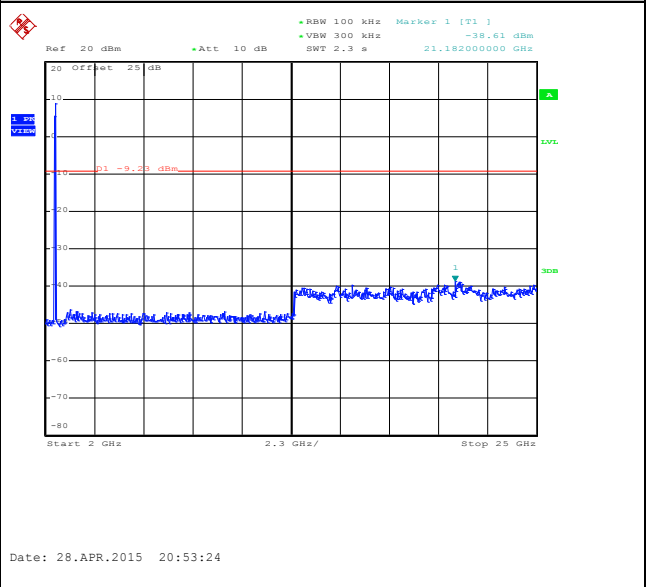



Number of TX :	2	Ant. :	2
Test Mode :	802.11g	Temperature :	21~25°C
Test Band :	2.4GHz Low	Relative Humidity :	51~54%
Test Channel :	01	Test Engineer :	Derek Hsu

WLAN 802.11g Channel 01

100kHz PSD reference Level

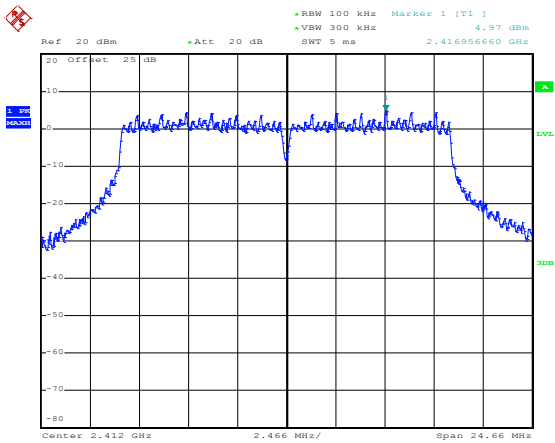

Date: 29.APR.2015 22:20:18

Low Channel Plot

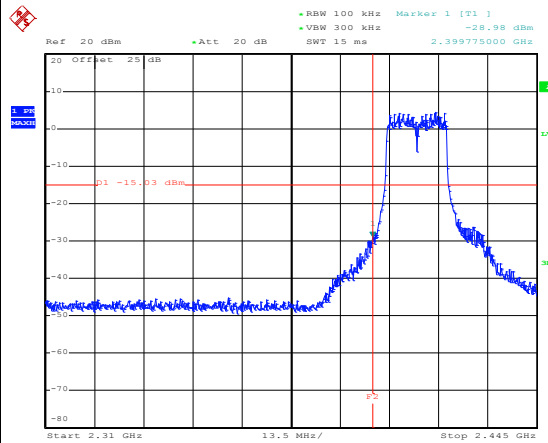

Date: 29.APR.2015 22:20:47

Spurious Emission 30MHz~3GHz

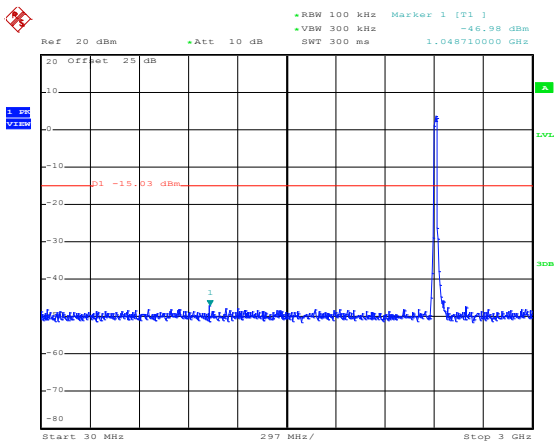

Date: 29.APR.2015 22:21:11

Spurious Emission 2GHz~25GHz

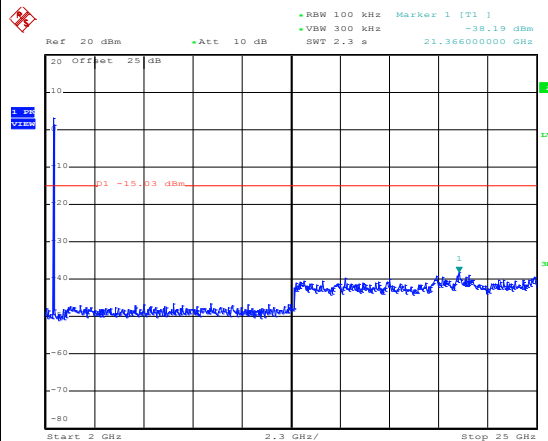

Date: 29.APR.2015 22:21:29



Number of TX :	2	Ant. :	2
Test Mode :	802.11g	Temperature :	21~25°C
Test Band :	2.4GHz Mid	Relative Humidity :	51~54%
Test Channel :	06	Test Engineer :	Derek Hsu

WLAN 802.11g Channel 06

100kHz PSD reference Level

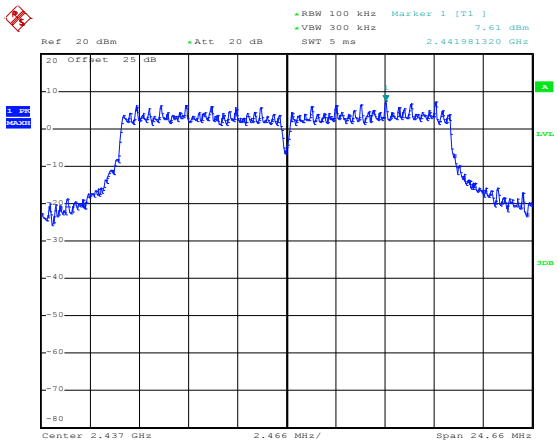

Date: 28.APR.2015 21:11:24

Spurious Emission 30MHz~3GHz

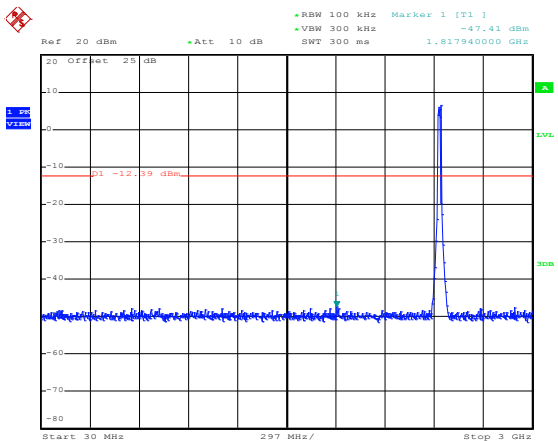

Date: 28.APR.2015 21:12:14

Spurious Emission 2GHz~25GHz

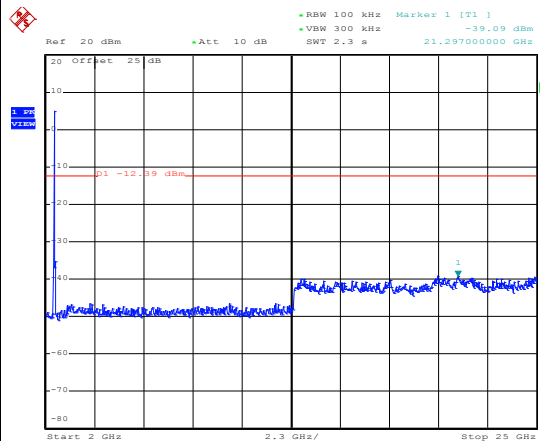

Date: 28.APR.2015 21:12:32



Number of TX :	2	Ant. :	2
Test Mode :	802.11g	Temperature :	21~25°C
Test Band :	2.4GHz High	Relative Humidity :	51~54%
Test Channel :	11	Test Engineer :	Derek Hsu

WLAN 802.11g Channel 11

100kHz PSD reference Level

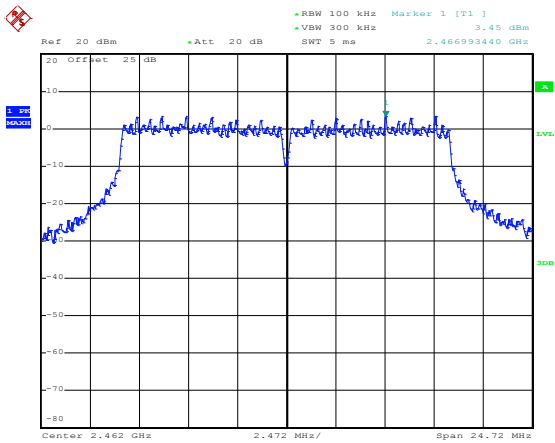

Date: 29.APR.2015 22:29:34

High Channel Plot

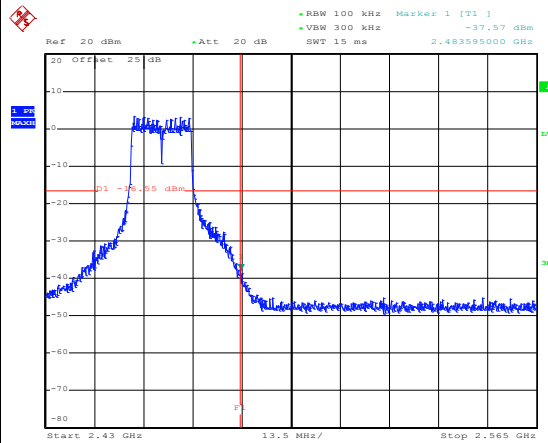

Date: 29.APR.2015 22:29:55

Spurious Emission 30MHz~3GHz

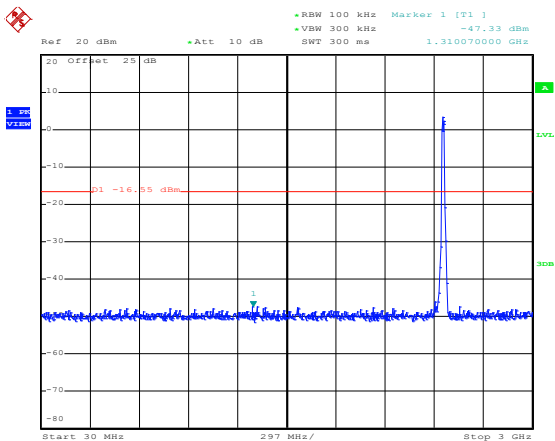

Date: 29.APR.2015 22:30:19

Spurious Emission 2GHz~25GHz

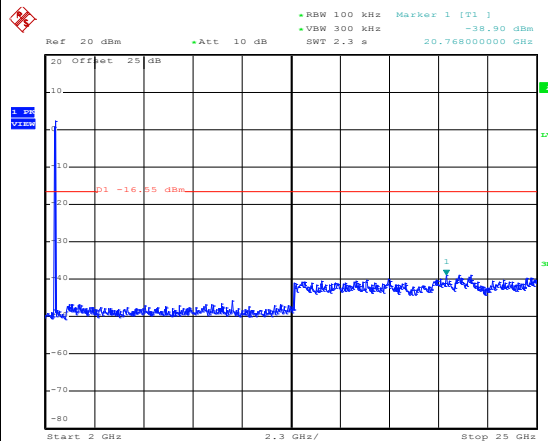

Date: 29.APR.2015 22:30:37



Number of TX :	2	Ant. :	2
Test Mode :	802.11n HT20	Temperature :	21~25°C
Test Band :	2.4GHz Low	Relative Humidity :	51~54%
Test Channel :	01	Test Engineer :	Derek Hsu

WLAN 802.11n HT20 Channel 01

100kHz PSD reference Level

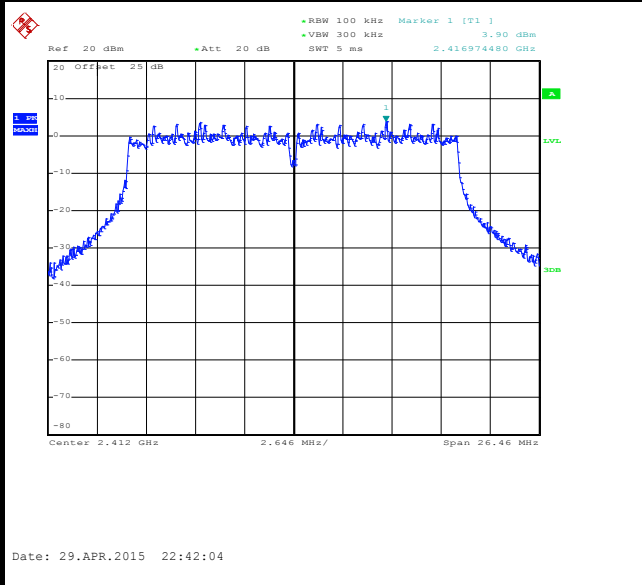

Low Channel Plot

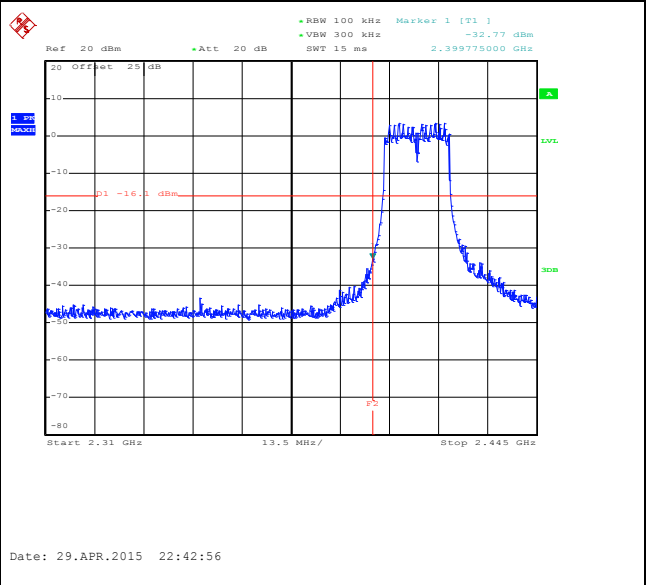

Spurious Emission 30MHz~3GHz

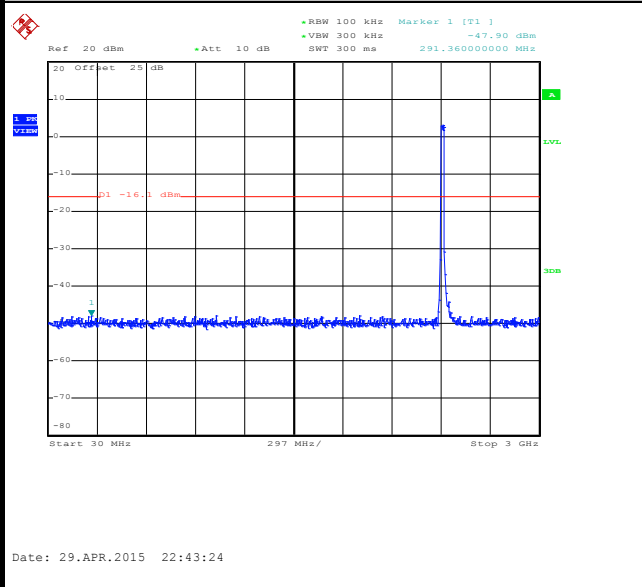

Spurious Emission 2GHz~25GHz

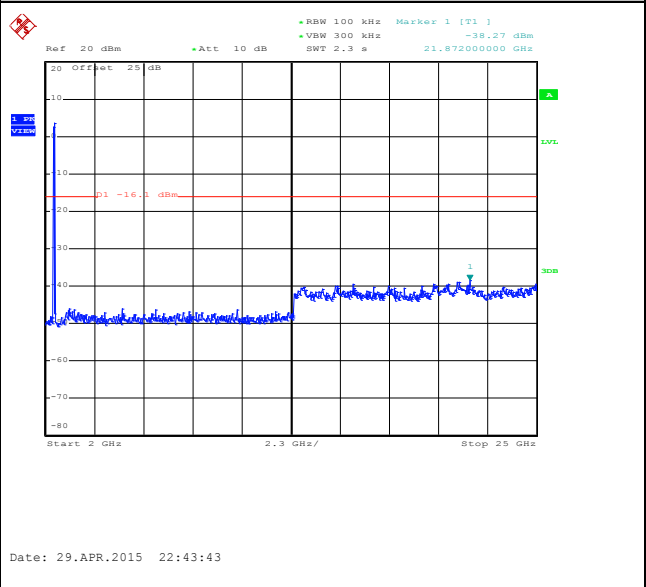



Number of TX :	2	Ant. :	2
Test Mode :	802.11n HT20	Temperature :	21~25°C
Test Band :	2.4GHz Mid	Relative Humidity :	51~54%
Test Channel :	06	Test Engineer :	Derek Hsu

WLAN 802.11n HT20 Channel 06

100kHz PSD reference Level

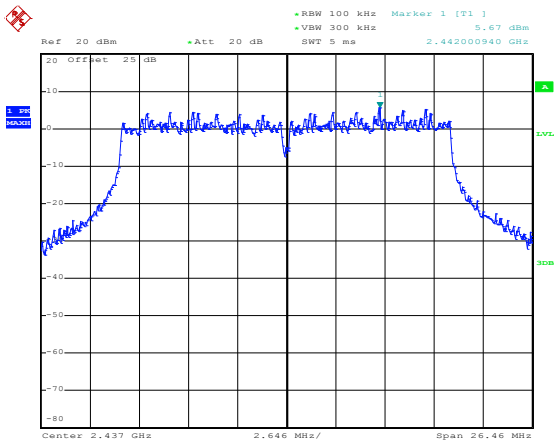

Date: 28.APR.2015 21:54:53

Spurious Emission 30MHz~3GHz

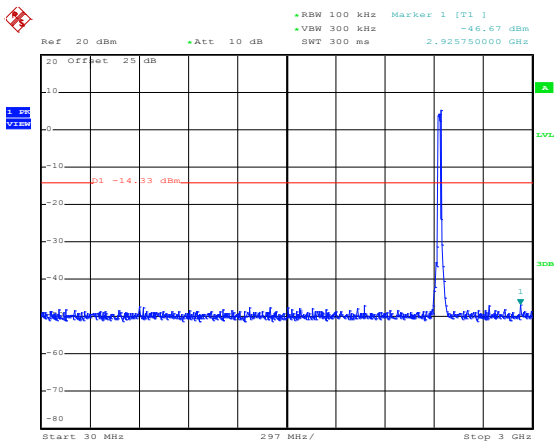

Date: 28.APR.2015 21:55:22

Spurious Emission 2GHz~25GHz

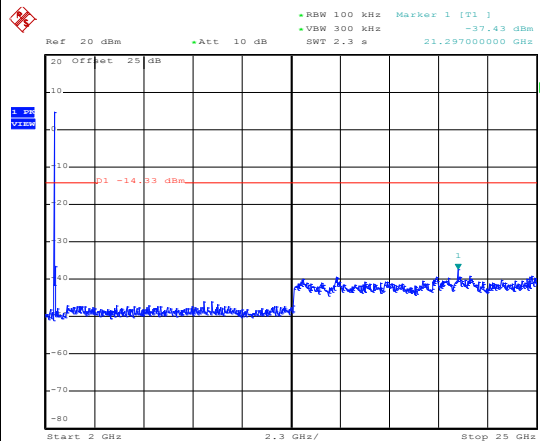

Date: 28.APR.2015 21:55:40



Number of TX :	2	Ant. :	2
Test Mode :	802.11n HT20	Temperature :	21~25°C
Test Band :	2.4GHz High	Relative Humidity :	51~54%
Test Channel :	11	Test Engineer :	Derek Hsu

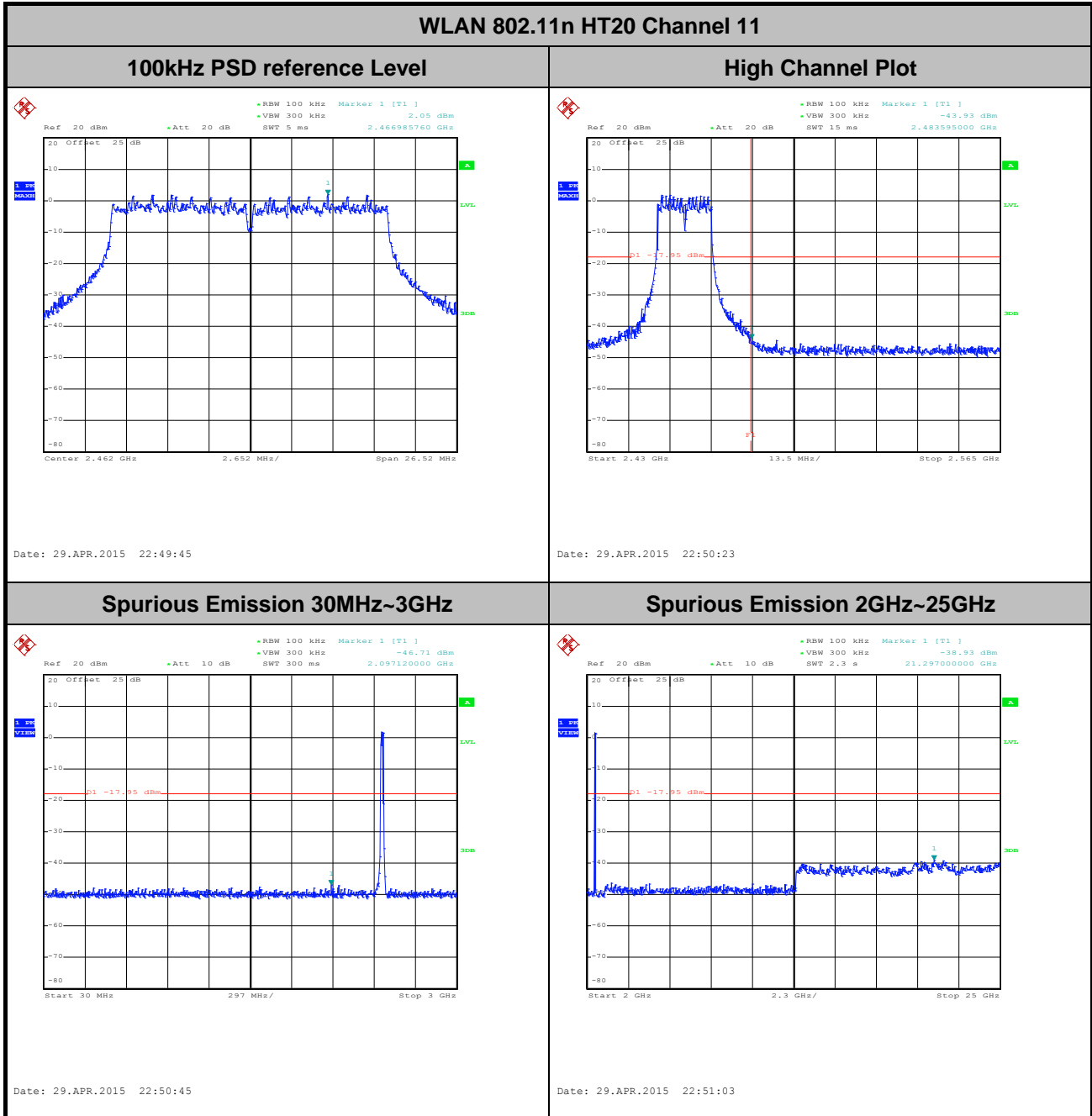



Number of TX :	2	Ant. :	2
Test Mode :	802.11ac VHT20	Temperature :	21~25°C
Test Band :	2.4GHz Low	Relative Humidity :	51~54%
Test Channel :	01	Test Engineer :	Derek Hsu

WLAN 802.11ac VHT20 Channel 01

100kHz PSD reference Level

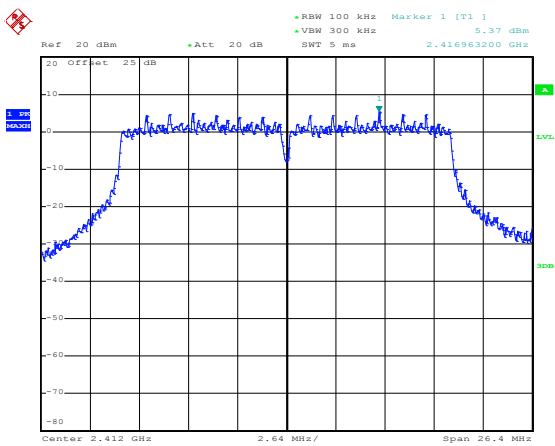

Date: 28.APR.2015 22:18:47

Low Channel Plot

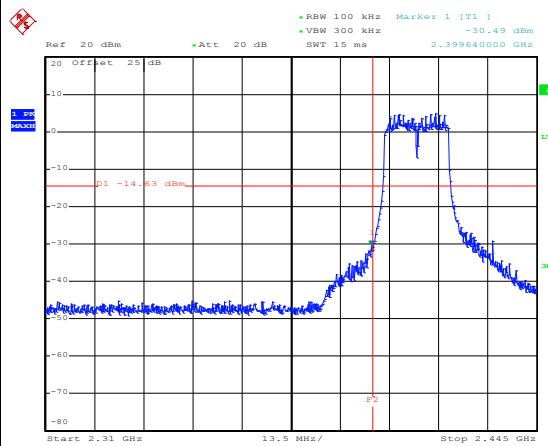

Date: 28.APR.2015 22:19:41

Spurious Emission 30MHz~3GHz

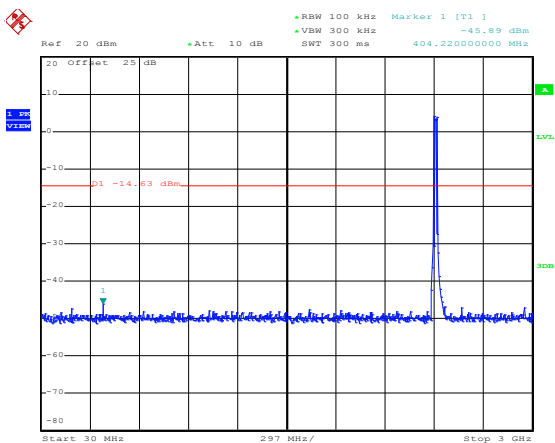

Date: 28.APR.2015 22:20:02

Spurious Emission 2GHz~25GHz

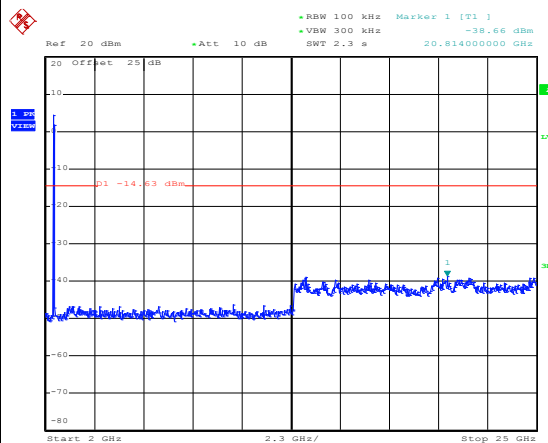

Date: 28.APR.2015 22:20:20



Number of TX :	2	Ant. :	2
Test Mode :	802.11ac VHT20	Temperature :	21~25°C
Test Band :	2.4GHz Mid	Relative Humidity :	51~54%
Test Channel :	06	Test Engineer :	Derek Hsu

WLAN 802.11ac VHT20 Channel 06

100kHz PSD reference Level

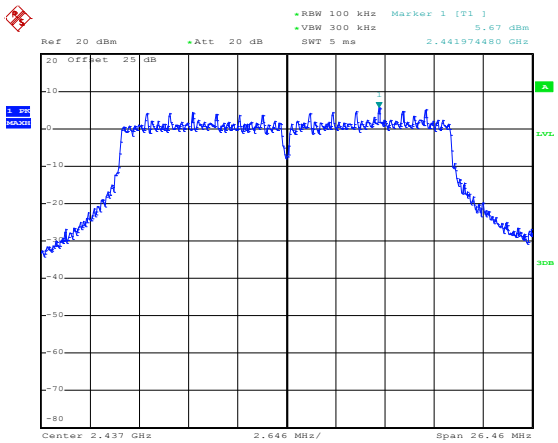

Date: 28.APR.2015 22:36:01

Spurious Emission 30MHz~3GHz

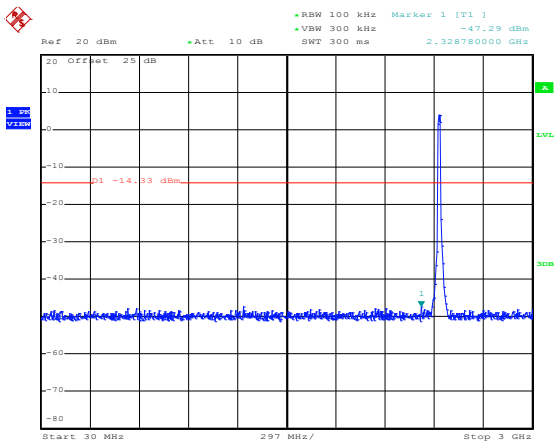

Date: 28.APR.2015 22:36:31

Spurious Emission 2GHz~25GHz

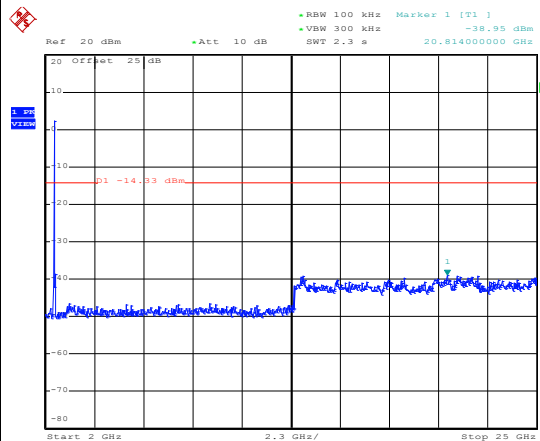

Date: 28.APR.2015 22:36:49



Number of TX :	2	Ant. :	2
Test Mode :	802.11ac VHT20	Temperature :	21~25°C
Test Band :	2.4GHz High	Relative Humidity :	51~54%
Test Channel :	11	Test Engineer :	Derek Hsu

WLAN 802.11ac VHT20 Channel 11

100kHz PSD reference Level

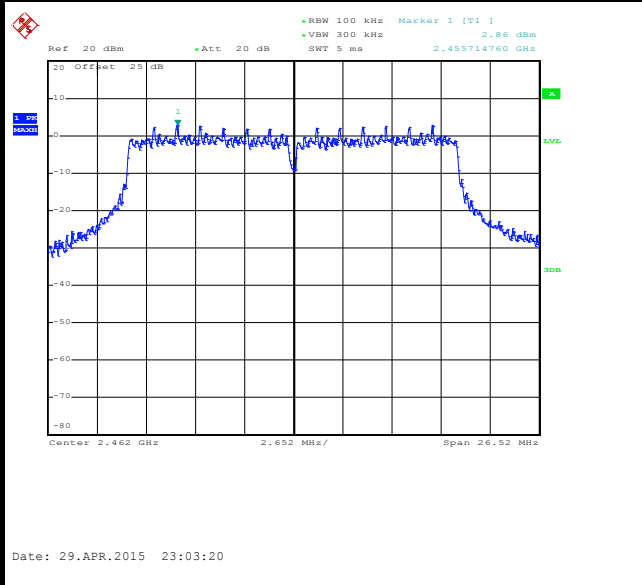

High Channel Plot

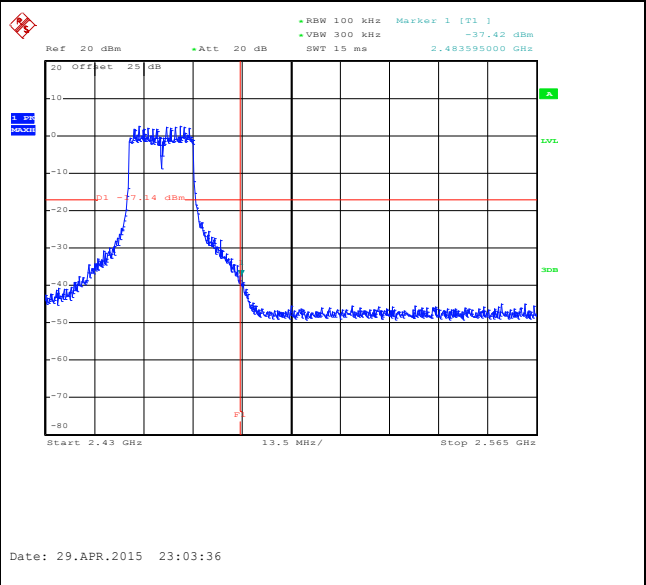

Spurious Emission 30MHz~3GHz

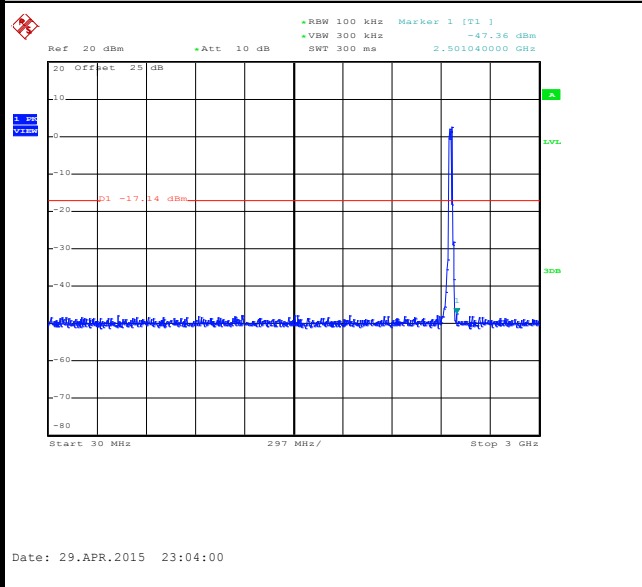

Spurious Emission 2GHz~25GHz

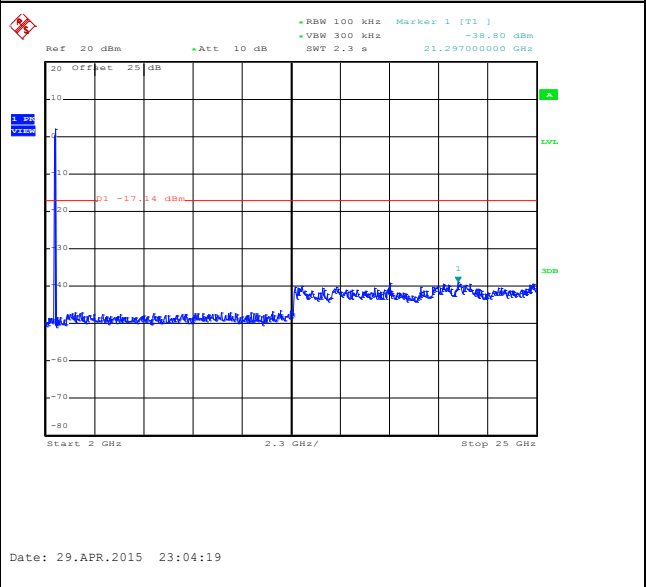



3.5 Radiated Band Edges and Spurious Emission Measurement

3.5.1 Limit of Radiated band edge and Spurious Emission Measurement

In any 100 kHz bandwidth outside the intentional radiator frequency band, all harmonics/spurious must be at least 20 dB below the highest emission level within the authorized band. If the output power of this device was measured by spectrum analyzer, the attenuation under this paragraph shall be 30 dB instead of 20 dB. In addition, radiated emissions which fall in the restricted bands must also comply with the FCC section 15.209 limits as below.

Frequency (MHz)	Field Strength (microvolts/meter)	Measurement Distance (meters)
0.009 – 0.490	2400/F(kHz)	300
0.490 – 1.705	24000/F(kHz)	30
1.705 – 30.0	30	30
30 – 88	100	3
88 – 216	150	3
216 - 960	200	3
Above 960	500	3

3.5.2 Measuring Instruments

The measuring equipment is listed in the section 4 of this test report.



3.5.3 Test Procedure

1. The testing follows FCC KDB Publication No. 558074 D01 DTS Meas. Guidance v03r02.
2. The EUT was arranged to its worst case and then tune the antenna tower (from 1 m to 4 m) and turntable (from 0 degree to 360 degrees) to find the maximum reading. A pre-amp and a high pass filter are used for the test in order to get better signal level.
3. The EUT was placed on a turntable with 0.8 meter for frequency below 1GHz and 1.5 meter for frequency above 1GHz respectively above ground.
4. The EUT was set 3 meters from the interference receiving antenna, which was mounted on the top of a variable height antenna tower.
5. Corrected Reading: Antenna Factor + Cable Loss + Read Level - Preamp Factor = Level
6. For measurement below 1GHz, If the emission level of the EUT measured by the peak detector is 3 dB lower than the applicable limit, the peak emission level will be reported. Otherwise, the emission measurement will be repeated using the quasi-peak detector and reported.
7. Use the following spectrum analyzer settings:
 - (1) Span shall wide enough to fully capture the emission being measured;
 - (2) Set RBW=100 kHz for $f < 1$ GHz; VBW \geq RBW; Sweep = auto; Detector function = peak; Trace = max hold;
 - (3) Set RBW = 1 MHz, VBW= 3MHz for $f \geq 1$ GHz for peak measurement.
For average measurement:
 - VBW = 10 Hz, when duty cycle is no less than 98 percent.
 - VBW $\geq 1/T$, when duty cycle is less than 98 percent where T is the minimum transmission duration over which the transmitter is on and is transmitting at its maximum power control level for the tested mode of operation.



Antenna	Band	Duty Cycle(%)	T(us)	1/T(kHz)	VBW Setting
1+2	2.4GHz 802.11b for Ant 1	99.05	-	-	10Hz
1+2	2.4GHz 802.11b for Ant 2	99.04	-	-	10Hz
1+2	2.4GHz 802.11g for Ant 1	84.37	540	1.851851852	3kHz
1+2	2.4GHz 802.11g for Ant 2	84.37	540	1.851851852	3kHz
1+2	2.4GHz 802.11n HT20 for Ant 1	74.19	276	3.623188406	10kHz
1+2	2.4GHz 802.11n HT20 for Ant 2	73.02	276	3.623188406	10kHz
1+2	2.4GHz 802.11ac VHT20 for Ant 1	84.42	520	1.923076923	3kHz
1+2	2.4GHz 802.11ac VHT20 for Ant 2	83.87	520	1.923076923	3kHz

3.5.4 Test Setup

For radiated emissions below 30MHz

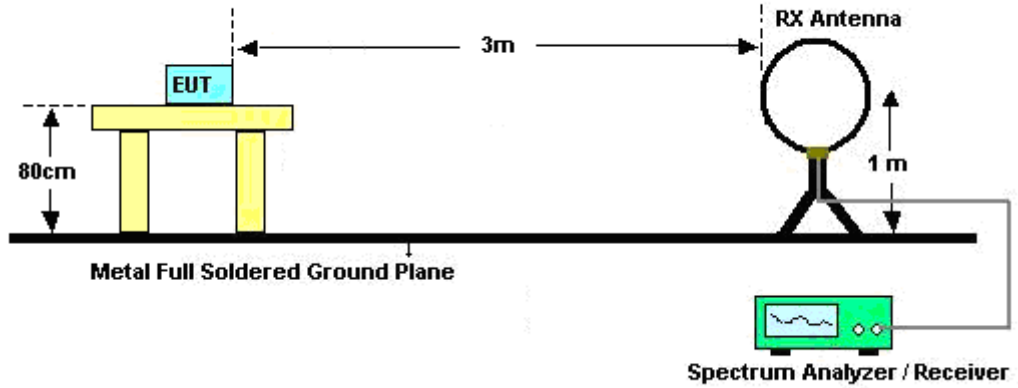

For radiated emissions from 30MHz to 1GHz

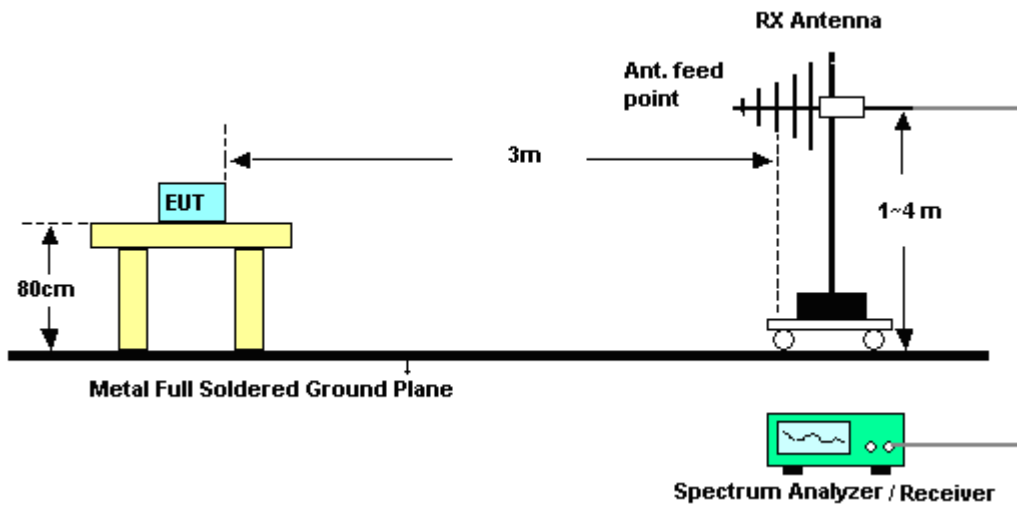

For radiated emissions above 1GHz

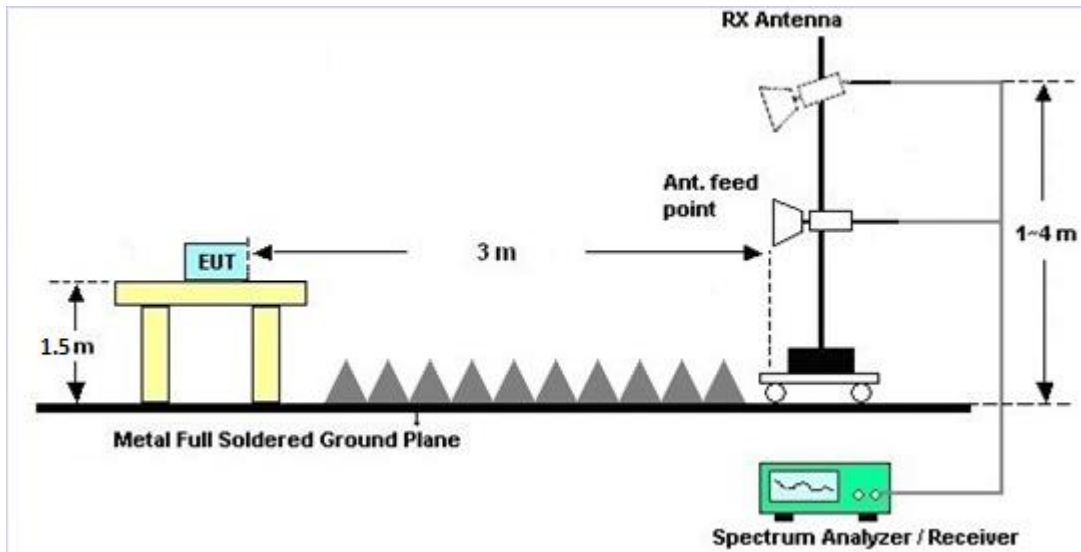

3.5.5 Test Results of Radiated Emissions (9kHz ~ 30MHz)

The low frequency, which started from 9 kHz to 30MHz, was pre-scanned and the result which was 20dB lower than the limit line per 15.31(o) was not reported.

3.5.6 Test Result of Radiated Spurious at Band Edges

Please refer to Appendix B of this report.

3.5.7 Test Result of Radiated Spurious Emission (30MHz ~ 10th Harmonic)

Please refer to Appendix B of this report.



3.6 AC Conducted Emission Measurement

3.6.1 Limit of AC Conducted Emission

For equipment that is designed to be connected to the public utility (AC) power line, the radio frequency voltage that is conducted back onto the AC power line on any frequency or frequencies within the band 150 kHz to 30 MHz shall not exceed the limits in the following table.

Frequency of Emission (MHz)	Conducted Limit (dBµV)	
	Quasi-Peak	Average
0.15-0.5	66 to 56*	56 to 46*
0.5-5	56	46
5-30	60	50

*Decreases with the logarithm of the frequency.

3.6.2 Measuring Instruments

The measuring equipment is listed in the section 4 of this test report.

3.6.3 Test Procedures

1. The EUT was placed 0.4 meter from the conducting wall of the shielding room, and it was kept at least 80 centimeters from any other grounded conducting surface.
2. Connect EUT to the power mains through a line impedance stabilization network (LISN).
3. All the support units are connecting to the other LISN.
4. The LISN provides 50 ohm coupling impedance for the measuring instrument.
5. The FCC states that a 50 ohm, 50 microhenry LISN should be used.
6. Both sides of AC line were checked for maximum conducted interference.
7. The frequency range from 150 kHz to 30 MHz was searched.
8. Set the test-receiver system to Peak Detect Function and specified bandwidth (IF bandwidth = 9kHz) with Maximum Hold Mode.

3.6.4 Test Setup

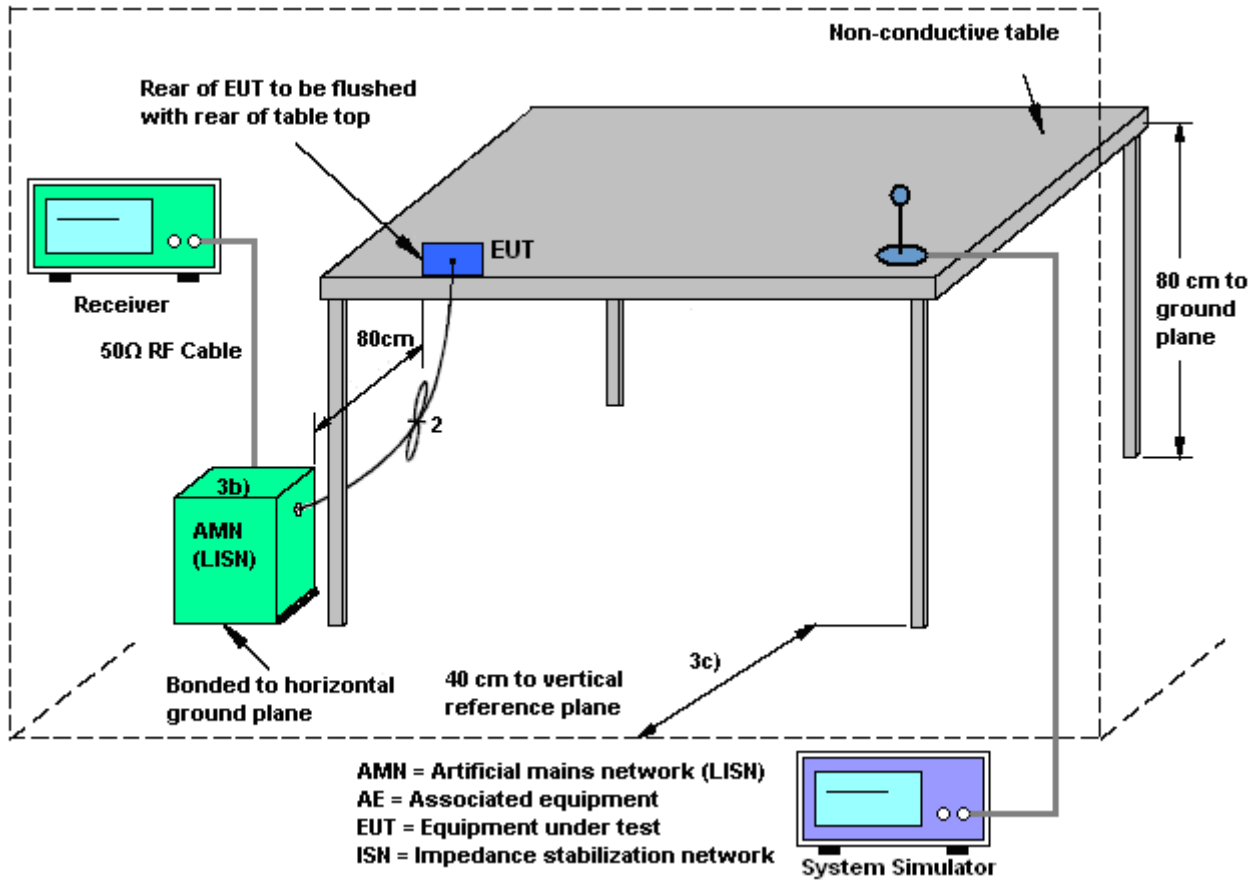

3.6.5 Test Result of AC Conducted Emission

Test Mode :	Mode 3	Temperature :	22~24°C
Test Engineer :	Eric Jeng	Relative Humidity :	49~51%
Test Voltage :	120Vac / 60Hz	Phase :	Line
Function Type :	GSM850 Idle + Bluetooth Link + WLAN Link + MP3 + Earphone + USB Cable (Charging from Adapter 3)		

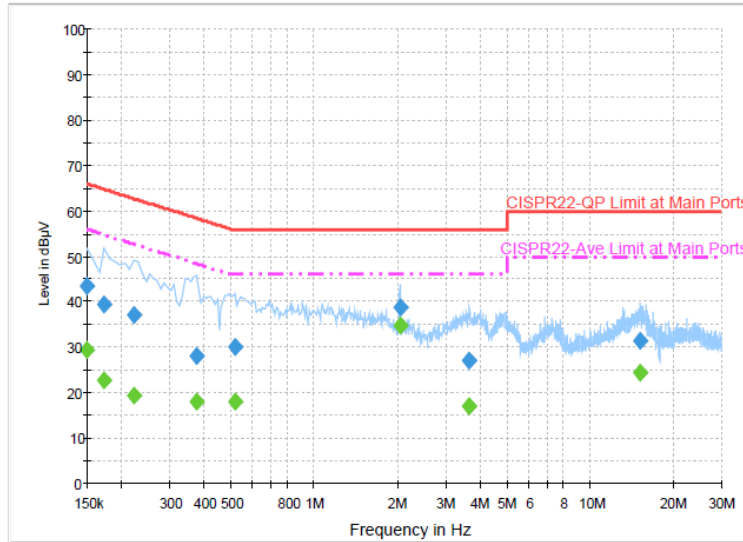

Final Result : Quasi-Peak

Frequency (MHz)	Quasi-Peak (dBµV)	Filter	Line	Corr. (dB)	Margin (dB)	Limit (dBµV)
0.150000	43.5	Off	L1	19.5	22.5	66.0
0.174000	39.4	Off	L1	19.4	25.4	64.8
0.222000	37.2	Off	L1	19.4	25.5	62.7
0.374000	28.2	Off	L1	19.5	30.2	58.4
0.518000	30.1	Off	L1	19.5	25.9	56.0
2.054000	38.7	Off	L1	19.7	17.3	56.0
3.662000	26.9	Off	L1	19.7	29.1	56.0
15.230000	31.5	Off	L1	20.0	28.5	60.0

Final Result : Average

Frequency (MHz)	Average (dBµV)	Filter	Line	Corr. (dB)	Margin (dB)	Limit (dBµV)
0.150000	29.3	Off	L1	19.5	26.7	56.0
0.174000	22.7	Off	L1	19.4	32.1	54.8
0.222000	19.5	Off	L1	19.4	33.2	52.7
0.374000	17.9	Off	L1	19.5	30.5	48.4
0.518000	18.0	Off	L1	19.5	28.0	46.0
2.054000	34.8	Off	L1	19.7	11.2	46.0
3.662000	16.9	Off	L1	19.7	29.1	46.0
15.230000	24.5	Off	L1	20.0	25.5	50.0



Test Mode :	Mode 3	Temperature :	22~24°C
Test Engineer :	Eric Jeng	Relative Humidity :	49~51%
Test Voltage :	120Vac / 60Hz	Phase :	Neutral
Function Type :	GSM850 Idle + Bluetooth Link + WLAN Link + MP3 + Earphone + USB Cable (Charging from Adapter 3)		

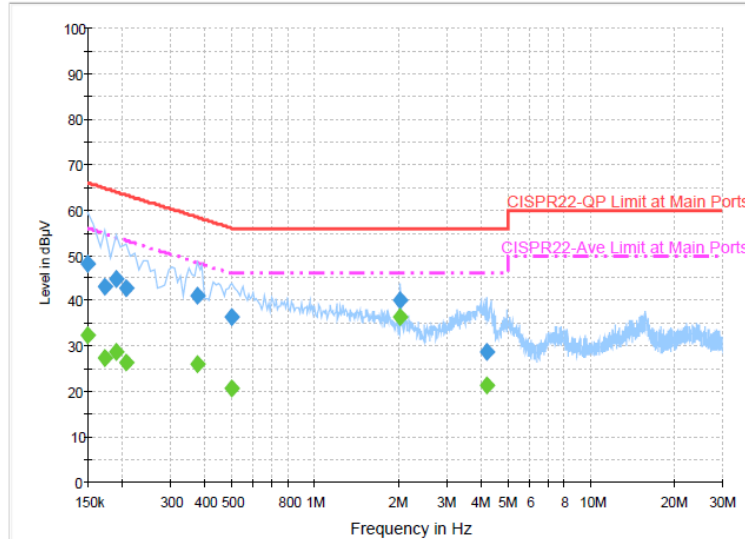

Final Result : Quasi-Peak

Frequency (MHz)	Quasi-Peak (dBµV)	Filter	Line	Corr. (dB)	Margin (dB)	Limit (dBµV)
0.150000	48.3	Off	N	19.5	17.7	66.0
0.174000	43.1	Off	N	19.4	21.7	64.8
0.190000	44.9	Off	N	19.5	19.1	64.0
0.206000	42.9	Off	N	19.4	20.5	63.4
0.374000	41.0	Off	N	19.5	17.4	58.4
0.502000	36.6	Off	N	19.5	19.4	56.0
2.046000	40.3	Off	N	19.7	15.7	56.0
4.182000	28.8	Off	N	19.7	27.2	56.0

Final Result : Average

Frequency (MHz)	Average (dBµV)	Filter	Line	Corr. (dB)	Margin (dB)	Limit (dBµV)
0.150000	32.5	Off	N	19.5	23.5	56.0
0.174000	27.4	Off	N	19.4	27.4	54.8
0.190000	28.6	Off	N	19.5	25.4	54.0
0.206000	26.5	Off	N	19.4	26.9	53.4
0.374000	26.1	Off	N	19.5	22.3	48.4
0.502000	20.9	Off	N	19.5	25.1	46.0
2.046000	36.5	Off	N	19.7	9.5	46.0
4.182000	21.5	Off	N	19.7	24.5	46.0

3.7 Antenna Requirements

3.7.1 Standard Applicable



If directional gain of transmitting Antennas is greater than 6dBi, the power shall be reduced by the same level in dB comparing to gain minus 6dBi. For the fixed point-to-point operation, the power shall be reduced by one dB for every 3 dB that the directional gain of the Antenna exceeds 6 dBi. The use of a permanently attached Antenna or of an Antenna that uses a unique coupling to the intentional radiator shall be considered sufficient to comply with the FCC rule.

3.7.2 Antenna Anti-Replacement Construction

An embedded-in antenna design is used.

3.7.3 Antenna Gain

FCC KDB 662911 D01 Multiple Transmitter Output v02r01.

For CDD transmissions, directional gain is calculated as

Directional gain = G_{ANT} + Array Gain, where Array Gain is as follows.

For power spectral density (PSD) measurements on all devices,

Array Gain = 10 log(N_{ANT}/N_{SS}=1) dB.

For power measurements on IEEE 802.11 devices,

Array Gain = 0 dB (i.e., no array gain) for N_{ANT} ≤ 4.

The EUT supports CDD mode.

The power and PSD limit should be modified if the directional gain of EUT is over 6 dBi,

The directional gain "DG" is calculated as following table.

	Ant. 1 (dBi)	Ant. 2 (dBi)	for Power (dBi)	for PSD (dBi)	Limit Reduction (dB)	Limit Reduction (dB)
2.4 GHz	-1.00	-4.00	0.64	0.64	0.00	0.00

Power Limit Reduction = DG(Power) – 6dBi, (min = 0)

PSD Limit Reduction = DG(PSD) – 6dBi, (min = 0)



4 List of Measuring Equipment

Instrument	Manufacturer	Model No.	Serial No.	Characteristics	Calibration Date	Test Date	Due Date	Remark
Power Meter	Anritsu	ML2495A	1036004	300MHz~40GHz	Aug. 09, 2014	Apr. 20, 2015~ Apr. 29, 2015	Aug. 08, 2015	Conducted (TH02-HY)
Power Sensor	Anritsu	MA2411B	1027253	300MHz~40GHz	Aug. 11, 2014	Apr. 20, 2015~ Apr. 29, 2015	Aug. 10, 2015	Conducted (TH02-HY)
Spectrum Analyzer	Rohde & Schwarz	FSP40	100055	9kHz~40GHz	Jun. 09, 2014	Apr. 20, 2015~ Apr. 29, 2015	Jun. 08, 2015	Conducted (TH02-HY)
Double Ridge Horn Antenna	ESCO	3117	00075962	1GHz ~ 18GHz	Aug. 19, 2014	Apr. 27, 2015~ May 15, 2015	Aug. 18, 2015	Radiation (03CH07-HY)
EMI Test Receiver	Rohde & Schwarz	ESCI 7	100724	9kHz~7GHz	Aug. 30, 2014	Apr. 27, 2015~ May 15, 2015	Aug. 29, 2015	Radiation (03CH07-HY)
Horn Antenna	SCHWARZBECK	BBHA 9170	BBHA9170 584	18GHz- 40GHz	Nov. 03, 2014	Apr. 27, 2015~ May 15, 2015	Nov. 02, 2015	Radiation (03CH07-HY)
Loop Antenna	Rohde & Schwarz	HFH2-Z2	100315	9 kHz~30 MHz	Jul. 28, 2014	Apr. 27, 2015~ May 15, 2015	Jul. 27, 2015	Radiation (03CH07-HY)
Preamplifier	MITEQ	AMF-7D-0010 1800-30-10P	1590075	1GHz ~ 18GHz	Apr. 20, 2015	Apr. 27, 2015~ May 15, 2015	Apr. 19, 2016	Radiation (03CH07-HY)
Preamplifier	COM-POWER	PA-103A	161241	10MHz-1000MHz	Mar. 12, 2015	Apr. 27, 2015~ May 15, 2015	Mar. 11, 2016	Radiation (03CH07-HY)
Preamplifier	Agilent	8449B	3008A023 62	1GHz~ 26.5GHz	Oct. 21, 2014	Apr. 27, 2015~ May 15, 2015	Oct. 20, 2015	Radiation (03CH07-HY)
Signal Analyzer	Rohde & Schwarz	FSV 30	101749	10Hz~30GHz	Mar. 10, 2015	Apr. 27, 2015~ May 15, 2015	Mar. 09, 2016	Radiation (03CH07-HY)
Antenna Mast	Max-Full	MFA520BS	N/A	1m~4m	N/A	Apr. 27, 2015~ May 15, 2015	N/A	Radiation (03CH07-HY)
Turn Table	ChainTek	Chaintek 3000	N/A	0~360 degree	N/A	Apr. 27, 2015~ May 15, 2015	N/A	Radiation (03CH07-HY)
Preamplifier	MITEQ	JS44-180040 00-33-8P	1840917	18GHz ~ 40GHz	Jun. 09, 2014	Apr. 27, 2015~ May 15, 2015	Jun. 08, 2015	Radiation (03CH07-HY)
Signal Analyzer	Rohde & Schwarz	FSV40	101397	10Hz~40GHz	Sep. 17, 2014	Apr. 27, 2015~ May 15, 2015	Sep. 16, 2015	Radiation (03CH07-HY)
Bilog Antenna	Schaffner	CBL6111C	2726	30MHz ~ 1GHz	Sep. 27, 2014	Apr. 27, 2015~ May 15, 2015	Sep. 26, 2015	Radiation (03CH07-HY)
EMI Test Receiver	Rohde & Schwarz	ESCS 30	100356	9kHz ~ 2.75GHz	Dec. 01, 2014	Apr. 21, 2015 ~ May 17, 2015	Nov. 30, 2015	Conduction (CO05-HY)
LISN	Rohde & Schwarz	ENV216	100080	9kHz~30MHz	Dec. 02, 2014	Apr. 21, 2015 ~ May 17, 2015	Dec. 01, 2015	Conduction (CO05-HY)
LISN (for auxiliary equipment)	Rohde & Schwarz	ENV216	100081	9kHz ~ 30MHz	Dec. 08, 2014	Apr. 21, 2015 ~ May 17, 2015	Dec. 07, 2015	Conduction (CO05-HY)
AC Power Source	ChainTek	APC-1000W	N/A	N/A	N/A	Apr. 21, 2015 ~ May 17, 2015	N/A	Conduction (CO05-HY)



5 Uncertainty of Evaluation

Uncertainty of Conducted Emission Measurement (150kHz ~ 30MHz)

Measuring Uncertainty for a Level of Confidence of 95% ($U = 2Uc(y)$)	2.26
---	------

Uncertainty of Radiated Emission Measurement (30 MHz ~ 1000 MHz)

Measuring Uncertainty for a Level of Confidence of 95% ($U = 2Uc(y)$)	4.50
---	------



Appendix A. Conducted Test Results

Test Engineer:	Derek Hsu	Temperature:	21~25	°C
Test Date:	2015/4/20~2015/4/29	Relative Humidity:	51~54	%

TEST RESULTS DATA
6dB and 99% Occupied Bandwidth

2.4GHz Band										
Mod.	Data Rate	N _{TX}	CH.	Freq. (MHz)	99% Occupied BW (MHz)		6dB BW (MHz)		6dB BW Limit (MHz)	Pass/Fail
					Ant 1	Ant 2	Ant 1	Ant 2		
11b	1Mbps	2	1	2412	14.15	14.55	8.08	8.06	0.50	Pass
11b	1Mbps	2	6	2437	13.75	14.35	8.06	8.04	0.50	Pass
11b	1Mbps	2	11	2462	14.75	15.10	8.04	8.06	0.50	Pass
11g	24Mbps	2	1	2412	17.75	17.80	16.44	16.44	0.50	Pass
11g	24Mbps	2	6	2437	18.20	18.50	16.44	16.44	0.50	Pass
11g	24Mbps	2	11	2462	17.95	18.05	16.48	16.48	0.50	Pass
HT20	MCS11	2	1	2412	19.05	18.60	17.64	17.64	0.50	Pass
HT20	MCS11	2	6	2437	18.90	18.80	17.64	17.64	0.50	Pass
HT20	MCS11	2	11	2462	19.15	18.75	17.64	17.68	0.50	Pass
VHT20	MCS3	2	1	2412	18.85	18.70	17.64	17.60	0.50	Pass
VHT20	MCS3	2	6	2437	18.70	18.85	17.68	17.64	0.50	Pass
VHT20	MCS3	2	11	2462	18.95	18.95	17.68	17.68	0.50	Pass

TEST RESULTS DATA
Peak Output Power

2.4GHz Band																
Mod.	Data Rate	NTX	CH.	Freq. (MHz)	Peak Conducted Power (dBm)			Conducted Power Limit (dBm)		DG (dBi)		EIRP Power (dBm)		EIRP Power Limit (dBm)		Pass /Fail
					Ant 1	Ant 2	SUM	Ant 1	Ant 2	Ant 1	Ant 2	Ant 1	Ant 2	Ant 1	Ant 2	
11b	1Mbps	2	1	2412	21.20	21.67	24.45	30.00		0.64		25.09		36.00	Pass	
11b	1Mbps	2	6	2437	21.17	21.59	24.40	30.00		0.64		25.03		36.00	Pass	
11b	1Mbps	2	11	2462	20.16	20.63	23.41	30.00		0.64		24.05		36.00	Pass	
11g	24Mbps	2	1	2412	24.07	23.88	26.99	30.00		0.64		27.63		36.00	Pass	
11g	24Mbps	2	6	2437	24.58	24.37	27.49	30.00		0.64		28.13		36.00	Pass	
11g	24Mbps	2	11	2462	22.73	23.05	25.90	30.00		0.64		26.54		36.00	Pass	
HT20	MCS11	2	1	2412	23.65	23.62	26.65	30.00		0.64		27.28		36.00	Pass	
HT20	MCS11	2	6	2437	24.11	24.30	27.22	30.00		0.64		27.86		36.00	Pass	
HT20	MCS11	2	11	2462	21.63	22.25	24.96	30.00		0.64		25.60		36.00	Pass	
VHT20	MCS3	2	1	2412	24.18	23.86	27.03	30.00		0.64		27.67		36.00	Pass	
VHT20	MCS3	2	6	2437	24.07	23.93	27.01	30.00		0.64		27.65		36.00	Pass	
VHT20	MCS3	2	11	2462	22.88	23.21	26.06	30.00		0.64		26.70		36.00	Pass	

Note: Measured power (dBm) has offset with cable loss.

TEST RESULTS DATA
Average Output Power

2.4GHz Band									
Mod.	Data Rate	N _{TX}	CH.	Freq. (MHz)	Duty Factor (dB)		Average Conducted Power (dBm)		
					Ant 1	Ant 2	Ant 1	Ant 2	SUM
11b	1Mbps	2	1	2412	0.04	0.04	18.80	19.40	22.12
11b	1Mbps	2	6	2437	0.04	0.04	18.43	19.22	21.85
11b	1Mbps	2	11	2462	0.04	0.04	17.90	18.49	21.22
11g	24Mbps	2	1	2412	0.74	0.74	14.94	15.64	18.31
11g	24Mbps	2	6	2437	0.74	0.74	17.14	17.78	20.48
11g	24Mbps	2	11	2462	0.74	0.74	13.92	14.61	17.29
HT20	MCS11	2	1	2412	1.30	1.37	14.21	15.02	17.64
HT20	MCS11	2	6	2437	1.30	1.37	15.82	16.52	19.19
HT20	MCS11	2	11	2462	1.30	1.37	12.76	13.58	16.20
VHT20	MCS3	2	1	2412	0.74	0.76	15.82	16.32	19.09
VHT20	MCS3	2	6	2437	0.74	0.76	15.67	16.32	18.99
VHT20	MCS3	2	11	2462	0.74	0.76	14.34	16.32	17.67

Note: Measured power (dBm) has offset with cable loss.

TEST RESULTS DATA
Peak Power Spectral Density

2.4GHz Band												
Mod.	Data Rate	NTX	CH.	Freq. (MHz)	Peak PSD (dBm/3kHz)			DG (dBi)		Peak PSD Limit (dBm/3kHz)		Pass/Fail
					Ant 1	Ant 2	Worse + 3.01	Ant 1	Ant 2	Ant 1	Ant 2	
11b	1Mbps	2	1	2412	-6.51	-5.95	-2.94	0.64		8.00		Pass
11b	1Mbps	2	6	2437	-7.18	-6.54	-3.53	0.64		8.00		Pass
11b	1Mbps	2	11	2462	-7.56	-5.96	-2.95	0.64		8.00		Pass
11g	24Mbps	2	1	2412	-9.98	-10.19	-6.97	0.64		8.00		Pass
11g	24Mbps	2	6	2437	-7.76	-7.99	-4.75	0.64		8.00		Pass
11g	24Mbps	2	11	2462	-12.00	-11.12	-8.11	0.64		8.00		Pass
HT20	MCS11	2	1	2412	-8.04	-5.49	-2.48	0.64		8.00		Pass
HT20	MCS11	2	6	2437	-7.10	-4.14	-1.13	0.64		8.00		Pass
HT20	MCS11	2	11	2462	-9.33	-7.42	-4.41	0.64		8.00		Pass
VHT20	MCS3	2	1	2412	-10.56	-9.65	-6.64	0.64		8.00		Pass
VHT20	MCS3	2	6	2437	-9.95	-10.15	-6.94	0.64		8.00		Pass
VHT20	MCS3	2	11	2462	-12.22	-11.89	-8.88	0.64		8.00		Pass

Measured power density (dBm) has offset with cable loss.



Appendix B. Radiated Spurious Emission

Test Engineer :	Nick Yu, Ken Wu and James Chiu	Temperature :	21~23 °C
		Relative Humidity :	60~63%

15C 2.4GHz 2400~2483.5MHz

WIFI 802.11b (Band Edge @ 3m)(with adapter1)

WIFI	Note	Frequency	Level	Over	Limit	Read	Antenna	Cable	Preamp	Ant	Table	Peak	Pol.	
Ant.				Limit	Line	Level	Factor	Loss	Factor	Pos	Pos	Avg.		
1+2		(MHz)	(dBµV/m)	(dB)	(dBµV/m)	(dBµV)	(dB/m)	(dB)	(dB)	(cm)	(deg)	(P/A)	(H/V)	
802.11b CH 01 2412MHz		2343.66	59.05	-14.95	74	53.51	32.11	7.68	34.25	127	135	P	H	
		2388.03	45.77	-8.23	54	40.11	32.18	7.75	34.27	127	135	A	H	
	*	2412	107.93	-	-	102.28	32.2	7.75	34.3	127	135	P	H	
	*	2412	103.17	-	-	97.52	32.2	7.75	34.3	127	135	A	H	
													H	
														H
			2347.98	58.79	-15.21	74	53.25	32.11	7.68	34.25	103	198	P	V
			2387.58	45.19	-8.81	54	39.53	32.18	7.75	34.27	103	198	A	V
	*		2412	105.76	-	-	100.11	32.2	7.75	34.3	103	198	P	V
	*		2412	101.22	-	-	95.57	32.2	7.75	34.3	103	198	A	V
													V	
													V	
802.11b CH 06 2437MHz		2318.37	59.42	-14.58	74	53.95	32.09	7.6	34.22	102	162	P	H	
		2388.93	44.93	-9.07	54	39.27	32.18	7.75	34.27	102	162	A	H	
	*	2437	108.1	-	-	102.38	32.24	7.83	34.35	102	162	P	H	
	*	2437	104.07	-	-	98.35	32.24	7.83	34.35	102	162	A	H	
			2484.28	59.49	-14.51	74	53.73	32.28	7.91	34.43	102	162	P	H
			2483.52	45	-9	54	39.24	32.28	7.91	34.43	102	162	A	H
			2322.96	58.6	-15.4	74	53.13	32.09	7.6	34.22	254	194	P	V
			2333.94	44.7	-9.3	54	39.23	32.09	7.6	34.22	254	194	A	V
	*		2437	104.48	-	-	98.76	32.24	7.83	34.35	254	194	P	V
	*		2437	99.06	-	-	93.34	32.24	7.83	34.35	254	194	A	V
		2488.12	59.67	-14.33	74	53.89	32.3	7.91	34.43	254	194	P	V	
		2483.52	44.96	-9.04	54	39.2	32.28	7.91	34.43	254	194	A	V	



802.11b CH 11 2462MHz	*	2462	105.17	-	-	99.39	32.26	7.91	34.39	100	132	P	H
	*	2462	100.35	-	-	94.57	32.26	7.91	34.39	100	132	A	H
		2483.8	61.53	-12.47	74	55.77	32.28	7.91	34.43	100	132	P	H
		2484.84	51.26	-2.74	54	45.5	32.28	7.91	34.43	100	132	A	H
													H
													H
	*	2462	103.93	-	-	98.15	32.26	7.91	34.39	103	205	P	V
	*	2462	99.05	-	-	93.27	32.26	7.91	34.39	103	205	A	V
		2484.76	61.02	-12.98	74	55.26	32.28	7.91	34.43	103	205	P	V
		2484.76	50.16	-3.84	54	44.4	32.28	7.91	34.43	103	205	A	V
													V
													V
Remark	1. No other spurious found. 2. All results are PASS against Peak and Average limit line.												



15C 2.4GHz 2400~2483.5MHz

WIFI 802.11b (Harmonic @ 3m) (with adapter1)

WIFI	Note	Frequency	Level	Over	Limit	Read	Antenna	Cable	Preamp	Ant	Table	Peak	Pol.
Ant.				Limit	Line	Level	Factor	Loss	Factor	Pos	Pos	Avg.	
1+2		(MHz)	(dBμV/m)	(dB)	(dBμV/m)	(dBμV)	(dB/m)	(dB)	(dB)	(cm)	(deg)	(P/A)	(H/V)
802.11b CH 01 2412MHz		4824	52.27	-21.73	74	66.49	34.26	11.16	59.64	100	0	P	H
													H
													H
													H
		4824	50.78	-23.22	74	65	34.26	11.16	59.64	100	0	P	V
													V
													V
													V
802.11b CH 06 2437MHz		4872	56.39	-17.61	74	70.45	34.3	11.21	59.57	131	314	P	H
		4872	52.93	-1.07	54	66.99	34.3	11.21	59.57	131	314	A	H
		7308	49.06	-24.94	74	56.85	35.6	15.08	58.47	100	0	P	H
													H
		4872	50.88	-23.12	74	64.94	34.3	11.21	59.57	100	0	P	V
		7308	44.63	-29.37	74	52.42	35.6	15.08	58.47	100	0	P	V
													V
													V
802.11b CH 11 2462MHz		4926	56.49	-17.51	74	70.38	34.34	11.27	59.5	138	321	P	H
		4926	52.98	-1.02	54	66.87	34.34	11.27	59.5	138	321	A	H
		7386	44.45	-29.55	74	52.29	35.6	15.14	58.58	100	0	P	H
													H
		4926	53.09	-20.91	74	66.98	34.34	11.27	59.5	226	80	P	V
		4926	49.77	-4.23	54	63.66	34.34	11.27	59.5	226	80	A	V
		7386	44.03	-29.97	74	51.87	35.6	15.14	58.58	100	0	P	V
													V
Remark	1. No other spurious found. 2. All results are PASS against Peak and Average limit line.												



15C 2.4GHz 2400~2483.5MHz

WIFI 802.11g (Band Edge @ 3m) (with adapter1)

WIFI	Note	Frequency	Level	Over	Limit	Read	Antenna	Cable	Preamp	Ant	Table	Peak	Pol.	
Ant.				Limit	Line	Level	Factor	Loss	Factor	Pos	Pos	Avg.		
1+2		(MHz)	(dBμV/m)	(dB)	(dBμV/m)	(dBμV)	(dB/m)	(dB)	(dB)	(cm)	(deg)	(P/A)	(H/V)	
802.11g CH 01 2412MHz		2389.47	70.17	-3.83	74	64.51	32.18	7.75	34.27	204	24	P	H	
		2390	52.81	-1.19	54	47.18	32.18	7.75	34.3	204	24	A	H	
	*	2412	110.57	-	-	104.92	32.2	7.75	34.3	204	24	P	H	
	*	2412	100.08	-	-	94.43	32.2	7.75	34.3	204	24	A	H	
													H	
													H	
			2389.65	66.16	-7.84	74	60.5	32.18	7.75	34.27	233	110	P	V
			2389.74	48.79	-5.21	54	43.13	32.18	7.75	34.27	233	110	A	V
	*		2410	106.37	-	-	100.72	32.2	7.75	34.3	233	110	P	V
	*		2410	95.85	-	-	90.2	32.2	7.75	34.3	233	110	A	V
														V
														V
802.11g CH 06 2437MHz		2389.74	71.1	-2.9	74	65.44	32.18	7.75	34.27	203	138	P	H	
		2389.56	48.9	-5.1	54	43.24	32.18	7.75	34.27	203	138	A	H	
	*	2437	111.1	-	-	105.38	32.24	7.83	34.35	203	138	P	H	
	*	2437	100.45	-	-	94.73	32.24	7.83	34.35	203	138	A	H	
			2484.36	67.69	-6.31	74	61.93	32.28	7.91	34.43	203	138	P	H
			2483.52	47.99	-6.01	54	42.23	32.28	7.91	34.43	203	138	A	H
			2388.48	64.74	-9.26	74	59.08	32.18	7.75	34.27	253	75	P	V
			2388.48	47.13	-6.87	54	41.47	32.18	7.75	34.27	253	75	A	V
	*		2437	106.49	-	-	100.77	32.24	7.83	34.35	253	75	P	V
	*		2437	96.93	-	-	91.21	32.24	7.83	34.35	253	75	A	V
			2483.64	60.75	-13.25	74	54.99	32.28	7.91	34.43	253	75	P	V
			2485	46.75	-7.25	54	40.99	32.28	7.91	34.43	253	75	A	V



802.11g CH 11 2462MHz	*	2462	105.56	-	-	99.78	32.26	7.91	34.39	100	173	P	H
	*	2462	94.73	-	-	88.95	32.26	7.91	34.39	100	173	A	H
		2483.56	69.28	-4.72	74	63.52	32.28	7.91	34.43	100	173	P	H
		2483.52	52.49	-1.51	54	46.73	32.28	7.91	34.43	100	173	A	H
													H
													H
	*	2462	103.97	-	-	98.19	32.26	7.91	34.39	102	204	P	V
	*	2462	92.86	-	-	87.08	32.26	7.91	34.39	102	204	A	V
		2484	68.81	-5.19	74	63.05	32.28	7.91	34.43	102	204	P	V
		2483.8	51.99	-2.01	54	46.23	32.28	7.91	34.43	102	204	A	V
													V
													V
Remark	1. No other spurious found. 2. All results are PASS against Peak and Average limit line.												



15C 2.4GHz 2400~2483.5MHz

WIFI 802.11g (Harmonic @ 3m) (with adapter1)

WIFI	Note	Frequency	Level	Over	Limit	Read	Antenna	Cable	Preamp	Ant	Table	Peak	Pol.
Ant.				Limit	Line	Level	Factor	Loss	Factor	Pos	Pos	Avg.	
1+2		(MHz)	(dBµV/m)	(dB)	(dBµV/m)	(dBµV)	(dB/m)	(dB)	(dB)	(cm)	(deg)	(P/A)	(H/V)
802.11g CH 01 2412MHz		4824	47.93	-26.07	74	62.15	34.26	11.16	59.64	100	0	P	H
													H
													H
													H
		4824	45.9	-28.1	74	60.12	34.26	11.16	59.64	100	0	P	V
													V
													V
													V
802.11g CH 06 2437MHz		4872	51.48	-22.52	74	65.54	34.3	11.21	59.57	100	0	P	H
		7332	43.57	-30.43	74	51.38	35.6	15.08	58.49	100	0	P	H
													H
													H
		4872	45.82	-28.18	74	59.88	34.3	11.21	59.57	100	0	P	V
		7332	43.24	-30.76	74	51.05	35.6	15.08	58.49	100	0	P	V
													V
													V
802.11g CH 11 2462MHz		4926	46.59	-27.41	74	60.48	34.34	11.27	59.5	100	0	P	H
		7386	43.28	-30.72	74	51.12	35.6	15.14	58.58	100	0	P	H
													H
													H
		4926	43.7	-30.3	74	57.59	34.34	11.27	59.5	100	0	P	V
		7386	43.29	-30.71	74	51.13	35.6	15.14	58.58	100	0	P	V
													V
													V
Remark	1. No other spurious found. 2. All results are PASS against Peak and Average limit line.												



15C 2.4GHz 2400~2483.5MHz

WIFI 802.11n HT20 (Band Edge @ 3m) (with adapter1)

WIFI	Note	Frequency	Level	Over	Limit	Read	Antenna	Cable	Preamp	Ant	Table	Peak	Pol.	
Ant.				Limit	Line	Level	Factor	Loss	Factor	Pos	Pos	Avg.		
1+2		(MHz)	(dBμV/m)	(dB)	(dBμV/m)	(dBμV)	(dB/m)	(dB)	(dB)	(cm)	(deg)	(P/A)	(H/V)	
802.11n HT20 CH 01 2412MHz		2390	68.8	-5.2	74	63.17	32.18	7.75	34.3	166	22	P	H	
		2390	51.65	-2.35	54	46.02	32.18	7.75	34.3	166	22	A	H	
	*	2410	108.32	-	-	102.67	32.2	7.75	34.3	166	22	P	H	
	*	2410	98.27	-	-	92.62	32.2	7.75	34.3	166	22	A	H	
													H	
													H	
			2389.65	63.02	-10.98	74	57.36	32.18	7.75	34.27	291	75	P	V
			2390	49.2	-4.8	54	43.57	32.18	7.75	34.3	291	75	A	V
		*	2412	105.05	-	-	99.4	32.2	7.75	34.3	291	75	P	V
		*	2412	94.34	-	-	88.69	32.2	7.75	34.3	291	75	A	V
													V	
													V	
802.11n HT20 CH 06 2437MHz		2341.05	58.83	-15.17	74	53.29	32.11	7.68	34.25	162	133	P	H	
		2385.42	47.02	-6.98	54	41.38	32.16	7.75	34.27	162	133	A	H	
	*	2437	107.59	-	-	101.87	32.24	7.83	34.35	162	133	P	H	
	*	2437	97.36	-	-	91.64	32.24	7.83	34.35	162	133	A	H	
			2486.92	59.79	-14.21	74	54.03	32.28	7.91	34.43	162	133	P	H
			2483.92	47.25	-6.75	54	41.49	32.28	7.91	34.43	162	133	A	H
			2322.69	59.52	-14.48	74	54.05	32.09	7.6	34.22	376	109	P	V
			2318.55	47.23	-6.77	54	41.76	32.09	7.6	34.22	376	109	A	V
		*	2437	104.66	-	-	98.94	32.24	7.83	34.35	376	109	P	V
		*	2437	93.88	-	-	88.16	32.24	7.83	34.35	376	109	A	V
		2497.32	58.84	-15.16	74	53.11	32.3	7.91	34.48	376	109	P	V	
		2484.04	47.11	-6.89	54	41.35	32.28	7.91	34.43	376	109	A	V	



802.11n HT20 CH 11 2462MHz	*	2462	105.19	-	-	99.41	32.26	7.91	34.39	200	27	P	H
	*	2462	93.88	-	-	88.1	32.26	7.91	34.39	200	27	A	H
		2484	66.71	-7.29	74	60.95	32.28	7.91	34.43	200	27	P	H
		2483.6	52.7	-1.3	54	46.94	32.28	7.91	34.43	200	27	A	H
													H
													H
	*	2462	100.81	-	-	95.03	32.26	7.91	34.39	276	75	P	V
	*	2462	89.87	-	-	84.09	32.26	7.91	34.39	276	75	A	V
		2483.76	62.89	-11.11	74	57.13	32.28	7.91	34.43	276	75	P	V
		2483.84	49.76	-4.24	54	44	32.28	7.91	34.43	276	75	A	V
													V
													V
Remark	1. No other spurious found. 2. All results are PASS against Peak and Average limit line.												



15C 2.4GHz 2400~2483.5MHz

WIFI 802.11n HT20 (Harmonic @ 3m) (with adapter1)

WIFI	Note	Frequency	Level	Over	Limit	Read	Antenna	Cable	Preamp	Ant	Table	Peak	Pol.	
Ant.				Limit	Line	Level	Factor	Loss	Factor	Pos	Pos	Avg.		
1+2		(MHz)	(dBμV/m)	(dB)	(dBμV/m)	(dBμV)	(dB/m)	(dB)	(dB)	(cm)	(deg)	(P/A)	(H/V)	
802.11n HT20 CH 01 2412MHz		4824	47.22	-26.78	74	61.44	34.26	11.16	59.64	100	0	P	H	
													H	
													H	
													H	
		4824	45.75	-28.25	74	59.97	34.26	11.16	59.64	100	0	P	V	
														V
														V
802.11n HT20 CH 06 2437MHz		4874	47.58	-26.42	74	61.64	34.3	11.21	59.57	100	0	P	H	
		7311	42.97	-31.03	74	50.76	35.6	15.08	58.47	100	0	P	H	
													H	
													H	
		4872	44.58	-29.42	74	58.64	34.3	11.21	59.57	100	0	P	V	
		7311	43.35	-30.65	74	51.14	35.6	15.08	58.47	100	0	P	V	
														V
802.11n HT20 CH 11 2462MHz		4924	48.91	-25.09	74	62.8	34.34	11.27	59.5	100	0	P	H	
		7386	43.06	-30.94	74	50.9	35.6	15.14	58.58	100	0	P	H	
													H	
													H	
		4924	41.39	-32.61	74	55.28	34.34	11.27	59.5	100	0	P	V	
		7386	43.68	-30.32	74	51.52	35.6	15.14	58.58	100	0	P	V	
														V
Remark	1. No other spurious found.													
	2. All results are PASS against Peak and Average limit line.													



15C 2.4GHz 2400~2483.5MHz

WIFI 802.11ac VHT20 (Band Edge @ 3m) (with adapter1)

WIFI	Note	Frequency	Level	Over	Limit	Read	Antenna	Cable	Preamp	Ant	Table	Peak	Pol.
Ant.				Limit	Line	Level	Factor	Loss	Factor	Pos	Pos	Avg.	
1+2		(MHz)	(dBμV/m)	(dB)	(dBμV/m)	(dBμV)	(dB/m)	(dB)	(dB)	(cm)	(deg)	(P/A)	(H/V)
802.11ac VHT20 CH 01 2412MHz		2389.92	66.34	-7.66	74	60.71	32.18	7.75	34.3	179	18	P	H
		2390	52.09	-1.91	54	46.46	32.18	7.75	34.3	179	18	A	H
	*	2410	110.1	-	-	104.45	32.2	7.75	34.3	179	18	P	H
	*	2410	98.64	-	-	92.99	32.2	7.75	34.3	179	18	A	H
		2489.12	59.4	-14.6	74	53.62	32.3	7.91	34.43	179	18	P	H
		2487.64	46.08	-7.92	54	40.3	32.3	7.91	34.43	179	18	A	H
		2390	62.02	-11.98	74	56.39	32.18	7.75	34.3	355	108	P	V
		2390	49.36	-4.64	54	43.73	32.18	7.75	34.3	355	108	A	V
	*	2412	104.06	-	-	98.41	32.2	7.75	34.3	355	108	P	V
	*	2412	93.63	-	-	87.98	32.2	7.75	34.3	355	108	A	V
		2489.36	59.7	-14.3	74	53.92	32.3	7.91	34.43	355	108	P	V
		2495.72	46.26	-7.74	54	40.53	32.3	7.91	34.48	355	108	A	V
802.11ac VHT20 CH 06 2437MHz		2355.72	59.32	-14.68	74	53.76	32.13	7.68	34.25	224	20	P	H
		2388.12	46.05	-7.95	54	40.39	32.18	7.75	34.27	224	20	A	H
	*	2437	107.96	-	-	102.24	32.24	7.83	34.35	224	20	P	H
	*	2439.329	96.69	-	-	90.97	32.24	7.83	34.35	224	20	A	H
		2498.16	59.42	-14.58	74	53.69	32.3	7.91	34.48	224	20	P	H
		2485.6	46.22	-7.78	54	40.46	32.28	7.91	34.43	224	20	A	H
		2373	58.87	-15.13	74	53.3	32.16	7.68	34.27	374	92	P	V
		2338.71	46.1	-7.9	54	40.61	32.11	7.6	34.22	374	92	A	V
	*	2437	102.04	-	-	96.32	32.24	7.83	34.35	374	92	P	V
	*	2437	90.77	-	-	85.05	32.24	7.83	34.35	374	92	A	V
		2496.64	59.03	-14.97	74	53.3	32.3	7.91	34.48	374	92	P	V
		2485.2	46.08	-7.92	54	40.32	32.28	7.91	34.43	374	92	A	V



802.11ac VHT20 CH 11 2462MHz		2362.38	59.04	-14.96	74	53.48	32.13	7.68	34.25	183	141	P	H
		2342.58	46.01	-7.99	54	40.47	32.11	7.68	34.25	183	141	A	H
	*	2464	105.65	-	-	99.87	32.26	7.91	34.39	183	141	P	H
	*	2464	94.19	-	-	88.41	32.26	7.91	34.39	183	141	A	H
		2483.6	66.87	-7.13	74	61.11	32.28	7.91	34.43	183	141	P	H
		2483.6	52.81	-1.19	54	47.05	32.28	7.91	34.43	183	141	A	H
		2323.23	58.63	-15.37	74	53.16	32.09	7.6	34.22	106	200	P	V
		2379.57	46	-8	54	40.43	32.16	7.68	34.27	106	200	A	V
	*	2464	99.58	-	-	93.8	32.26	7.91	34.39	106	200	P	V
	*	2464	88.83	-	-	83.05	32.26	7.91	34.39	106	200	A	V
		2483.64	62.6	-11.4	74	56.84	32.28	7.91	34.43	106	200	P	V
		2483.6	48.26	-5.74	54	42.5	32.28	7.91	34.43	106	200	A	V
Remark	1. No other spurious found. 2. All results are PASS against Peak and Average limit line.												



15C 2.4GHz 2400~2483.5MHz

WIFI 802.11ac VHT20 (Harmonic @ 3m) (with adapter1)

WIFI	Note	Frequency	Level	Over	Limit	Read	Antenna	Cable	Preamp	Ant	Table	Peak	Pol.
Ant.				Limit	Line	Level	Factor	Loss	Factor	Pos	Pos	Avg.	
1+2		(MHz)	(dBμV/m)	(dB)	(dBμV/m)	(dBμV)	(dB/m)	(dB)	(dB)	(cm)	(deg)	(P/A)	(H/V)
802.11ac VHT20 CH 01 2412MHz		4824	49.3	-24.7	74	63.52	34.26	11.16	59.64	100	0	P	H
													H
													H
													H
		4824	41.83	-32.17	74	56.05	34.26	11.16	59.64	100	0	P	V
													V
													V
802.11ac VHT20 CH 06 2437MHz		4872	48.56	-25.44	74	62.62	34.3	11.21	59.57	100	0	P	H
		7311	43.24	-30.76	74	51.03	35.6	15.08	58.47	100	0	P	H
													H
													H
		4872	42.06	-31.94	74	56.12	34.3	11.21	59.57	100	0	P	V
		7311	44.69	-29.31	74	52.48	35.6	15.08	58.47	100	0	P	V
													V
802.11ac VHT20 CH 11 2462MHz		4926	44.92	-29.08	74	58.81	34.34	11.27	59.5	100	0	P	H
		7386	43.07	-30.93	74	50.91	35.6	15.14	58.58	100	0	P	H
													H
													H
		4924	42.11	-31.89	74	56	34.34	11.27	59.5	100	0	P	V
		7386	43.58	-30.42	74	51.42	35.6	15.14	58.58	100	0	P	V
													V
Remark	1. No other spurious found.												
	2. All results are PASS against Peak and Average limit line.												



15C Emission below 1GHz

2.4GHz WIFI 802.11b (LF) (with adapter1)

WIFI	Note	Frequency	Level	Over	Limit	Read	Antenna	Cable	Preamp	Ant	Table	Peak	Pol.	
Ant.				Limit	Line	Level	Factor	Loss	Factor	Pos	Pos	Avg.		
1+2		(MHz)	(dBμV/m)	(dB)	(dBμV/m)	(dBμV)	(dB/m)	(dB)	(dB)	(cm)	(deg)	(P/A)	(H/V)	
2.4GHz 802.11b LF		47.55	32.64	-7.36	40	52.62	9.45	1.77	31.2	113	57	P	H	
		152.31	25.54	-17.96	43.5	43.3	10.76	2.61	31.13	-	-	P	H	
		211.98	29.45	-14.05	43.5	48.62	9.22	2.69	31.08	-	-	P	H	
		421.8	23.49	-22.51	46	33.91	16.74	3.63	30.79	-	-	P	H	
		587.7	22.89	-23.11	46	29.94	19.52	4.08	30.65	-	-	P	H	
		995.8	29.94	-24.06	54	30.45	24.68	5.03	30.22	-	-	P	H	
														H
														H
														H
														H
														H
														H
														H
			55.11	27.67	-12.33	40	50.7	6.4	1.77	31.2	103	231	P	V
			142.86	20.07	-23.43	43.5	37.06	11.5	2.61	31.1	-	-	P	V
			285.96	19.55	-26.45	46	34.43	12.98	3.16	31.02	-	-	P	V
			344.1	16.76	-29.24	46	30.17	14.22	3.39	31.02	-	-	P	V
			561.8	23.22	-22.78	46	30.01	19.95	4.01	30.75	-	-	P	V
			968.5	28.98	-25.02	54	29.58	24.79	4.94	30.33	-	-	P	V
														V
													V	
													V	
													V	
													V	
													V	
Remark	1. No other spurious found. 2. All results are PASS against limit line.													



15C 2.4GHz 2400~2483.5MHz

WIFI 802.11b (Band Edge @ 3m) (with adapter2)

WIFI	Note	Frequency	Level	Over	Limit	Read	Antenna	Cable	Preamp	Ant	Table	Peak	Pol.
Ant.				Limit	Line	Level	Factor	Loss	Factor	Pos	Pos	Avg.	
1+2		(MHz)	(dBμV/m)	(dB)	(dBμV/m)	(dBμV)	(dB/m)	(dB)	(dB)	(cm)	(deg)	(P/A)	(H/V)
802.11b CH 11 2462MHz	*	2462	108.21	-	-	102.43	32.26	7.91	34.39	173	20	P	H
	*	2462	103.06	-	-	97.28	32.26	7.91	34.39	173	20	A	H
		2484.04	61.8	-12.2	74	56.04	32.28	7.91	34.43	173	20	P	H
		2483.56	50.99	-3.01	54	45.23	32.28	7.91	34.43	173	20	A	H
													H
													H
	*	2462	105.07	-	-	99.29	32.26	7.91	34.39	100	3	P	V
	*	2462	100.72	-	-	94.94	32.26	7.91	34.39	100	3	A	V
		2483.68	61.35	-12.65	74	55.59	32.28	7.91	34.43	100	3	P	V
		2484.48	50.44	-3.56	54	44.68	32.28	7.91	34.43	100	3	A	V
													V
													V
Remark	1. No other spurious found. 2. All results are PASS against Peak and Average limit line.												



15C 2.4GHz 2400~2483.5MHz

WIFI 802.11b (Harmonic @ 3m) (with adapter2)

WIFI	Note	Frequency	Level	Over	Limit	Read	Antenna	Cable	Preamp	Ant	Table	Peak	Pol.
Ant.				Limit	Line	Level	Factor	Loss	Factor	Pos	Pos	Avg.	
1+2		(MHz)	(dBμV/m)	(dB)	(dBμV/m)	(dBμV)	(dB/m)	(dB)	(dB)	(cm)	(deg)	(P/A)	(H/V)
802.11b CH 11 2462MHz		4926	56.06	-17.94	74	69.95	34.34	11.27	59.5	158	310	P	H
		4926	52.23	-1.77	54	66.12	34.34	11.27	59.5	158	310	A	H
		7386	44.19	-29.81	74	52.03	35.6	15.14	58.58	100	0	P	H
													H
		4926	49.34	-24.66	74	63.23	34.34	11.27	59.5	100	0	P	V
		7386	43.6	-30.4	74	51.44	35.6	15.14	58.58	100	0	P	V
													V
													V
Remark	1. No other spurious found. 2. All results are PASS against Peak and Average limit line.												



15C Emission below 1GHz

2.4GHz WIFI 802.11b (LF) (with adapter2)

WIFI	Note	Frequency	Level	Over	Limit	Read	Antenna	Cable	Preamp	Ant	Table	Peak	Pol.	
Ant.				Limit	Line	Level	Factor	Loss	Factor	Pos	Pos	Avg.		
1+2		(MHz)	(dBμV/m)	(dB)	(dBμV/m)	(dBμV)	(dB/m)	(dB)	(dB)	(cm)	(deg)	(P/A)	(H/V)	
2.4GHz 802.11b LF		90.75	29.68	-13.82	43.5	49.92	8.8	2.06	31.1	-	-	P	H	
		149.61	32.74	-10.76	43.5	50.29	10.94	2.61	31.1	106	213	P	H	
		238.44	32.36	-13.64	46	49.22	11.18	2.96	31	-	-	P	H	
		475.7	34.31	-11.69	46	43.79	17.55	3.77	30.8	-	-	P	H	
		643.7	28.49	-17.51	46	34.38	20.4	4.22	30.51	-	-	P	H	
		933.5	29.44	-16.56	46	30.71	24.3	4.8	30.37	-	-	P	H	
														H
														H
														H
														H
														H
														H
														H
			67.8	30.61	-9.39	40	53.57	6.24	2.06	31.26	101	259	P	V
			149.34	26.02	-17.48	43.5	43.57	10.94	2.61	31.1	-	-	P	V
			236.28	30.16	-15.84	46	47.26	10.94	2.96	31	-	-	P	V
			456.8	30.28	-15.72	46	40.06	17.37	3.63	30.78	-	-	P	V
			701.8	24.6	-21.4	46	29.91	20.68	4.41	30.4	-	-	P	V
			869.1	27.63	-18.37	46	30.31	23.02	4.66	30.36	-	-	P	V
														V
													V	
													V	
													V	
													V	
													V	
Remark	1. No other spurious found. 2. All results are PASS against limit line.													



15C 2.4GHz 2400~2483.5MHz

WIFI 802.11b (Band Edge @ 3m) (with adapter3)

WIFI	Note	Frequency	Level	Over	Limit	Read	Antenna	Cable	Preamp	Ant	Table	Peak	Pol.
Ant.				Limit	Line	Level	Factor	Loss	Factor	Pos	Pos	Avg.	
1+2		(MHz)	(dBμV/m)	(dB)	(dBμV/m)	(dBμV)	(dB/m)	(dB)	(dB)	(cm)	(deg)	(P/A)	(H/V)
802.11b CH 11 2462MHz	*	2462	109.06	-	-	103.28	32.26	7.91	34.39	174	15	P	H
	*	2462	104.72	-	-	98.94	32.26	7.91	34.39	174	15	A	H
		2483.8	62.21	-11.79	74	56.45	32.28	7.91	34.43	174	15	P	H
		2483.52	52.5	-1.5	54	46.74	32.28	7.91	34.43	174	15	A	H
													H
													H
	*	2462	103.86	-	-	98.08	32.26	7.91	34.39	100	161	P	V
	*	2462	99.6	-	-	93.82	32.26	7.91	34.39	100	161	A	V
		2485.48	59.77	-14.23	74	54.01	32.28	7.91	34.43	100	161	P	V
		2483.52	47.28	-6.72	54	41.52	32.28	7.91	34.43	100	161	A	V
													V
													V
Remark	1. No other spurious found. 2. All results are PASS against Peak and Average limit line.												



15C 2.4GHz 2400~2483.5MHz

WIFI 802.11b (Harmonic @ 3m) (with adapter3)

WIFI	Note	Frequency	Level	Over	Limit	Read	Antenna	Cable	Preamp	Ant	Table	Peak	Pol.
Ant.				Limit	Line	Level	Factor	Loss	Factor	Pos	Pos	Avg.	
1+2		(MHz)	(dBμV/m)	(dB)	(dBμV/m)	(dBμV)	(dB/m)	(dB)	(dB)	(cm)	(deg)	(P/A)	(H/V)
802.11b CH 11 2462MHz		4926	54.94	-19.06	74	68.83	34.34	11.27	59.5	100	321	P	H
		4926	51.99	-2.01	54	65.88	34.34	11.27	59.5	100	321	A	H
		7386	44.61	-29.39	74	52.45	35.6	15.14	58.58	100	0	P	H
													H
		4924	48.47	-25.53	74	62.36	34.34	11.27	59.5	100	0	P	V
		7386	42.9	-31.1	74	50.74	35.6	15.14	58.58	100	0	P	V
													V
													V
Remark	1. No other spurious found. 2. All results are PASS against Peak and Average limit line.												



15C Emission below 1GHz

2.4GHz WIFI 802.11b (LF) (with adapter3)

WIFI	Note	Frequency	Level	Over	Limit	Read	Antenna	Cable	Preamp	Ant	Table	Peak	Pol.	
Ant.				Limit	Line	Level	Factor	Loss	Factor	Pos	Pos	Avg.		
1+2		(MHz)	(dBμV/m)	(dB)	(dBμV/m)	(dBμV)	(dB/m)	(dB)	(dB)	(cm)	(deg)	(P/A)	(H/V)	
2.4GHz 802.11b LF		52.41	31.46	-8.54	40	53.29	7.6	1.77	31.2	103	214	P	H	
		91.29	29.88	-13.62	43.5	50.12	8.8	2.06	31.1	-	-	P	H	
		254.1	28.54	-17.46	46	43.54	13.04	2.96	31	-	-	P	H	
		464.5	33.58	-12.42	46	43.16	17.45	3.77	30.8	-	-	P	H	
		727.7	25.95	-20.05	46	30.1	21.84	4.41	30.4	-	-	P	H	
		897.8	28.71	-17.29	46	31.21	23.14	4.66	30.3	-	-	P	H	
														H
														H
														H
														H
														H
														H
														H
			80.22	30.05	-9.95	40	52.17	7	2.06	31.18	100	268	P	V
			149.61	26.59	-16.91	43.5	44.14	10.94	2.61	31.1	-	-	P	V
			239.25	32.28	-13.72	46	49.02	11.3	2.96	31	-	-	P	V
			482	30.87	-15.13	46	40.22	17.66	3.77	30.78	-	-	P	V
			716.5	25.04	-20.96	46	29.75	21.28	4.41	30.4	-	-	P	V
			926.5	30.08	-15.92	46	31.45	24.18	4.8	30.35	-	-	P	V
														V
													V	
													V	
													V	
													V	
													V	
Remark	1. No other spurious found. 2. All results are PASS against limit line.													



Note symbol

*	Fundamental Frequency which can be ignored. However, the level of any unwanted emissions shall not exceed the level of the fundamental frequency per 15.209(c).
!	Test result is over limit line.
P/A	Peak or Average
H/V	Horizontal or Vertical



A calculation example for radiated spurious emission is shown as below:

WIFI	Note	Frequency	Level	Over	Limit	Read	Antenna	Cable	Preamp	Ant	Table	Peak	Pol.
Ant.				Limit	Line	Level	Factor	Loss	Factor	Pos	Pos	Avg.	
1+2		(MHz)	(dBμV/m)	(dB)	(dBμV/m)	(dBμV)	(dB/m)	(dB)	(dB)	(cm)	(deg)	(P/A)	(H/V)
802.11b		2390	55.45	-18.55	74	54.51	32.22	4.58	35.86	103	308	P	H
CH 01		2390	43.54	-10.46	54	42.6	32.22	4.58	35.86	103	308	A	H
2412MHz													

- Level(dBμV/m) =
Antenna Factor(dB/m) + Cable Loss(dB) + Read Level(dBμV) - Preamp Factor(dB)
- Over Limit(dB) = Level(dBμV/m) – Limit Line(dBμV/m)

For Peak Limit @ 2390MHz:

- Level(dBμV/m)
= Antenna Factor(dB/m) + Cable Loss(dB) + Read Level(dBμV) - Preamp Factor(dB)
= 32.22(dB/m) + 4.58(dB) + 54.51(dBμV) – 35.86 (dB)
= 55.45 (dBμV/m)
- Over Limit(dB)
= Level(dBμV/m) – Limit Line(dBμV/m)
= 55.45(dBμV/m) – 74(dBμV/m)
= -18.55(dB)

For Average Limit @ 2390MHz:

- Level(dBμV/m)
= Antenna Factor(dB/m) + Cable Loss(dB) + Read Level(dBμV) - Preamp Factor(dB)
= 32.22(dB/m) + 4.58(dB) + 42.6(dBμV) – 35.86 (dB)
= 43.54 (dBμV/m)
- Over Limit(dB)
= Level(dBμV/m) – Limit Line(dBμV/m)
= 43.54(dBμV/m) – 54(dBμV/m)
= -10.46(dB)

Both peak and average measured complies with the limit line, so test result is “PASS”.