



LTE Band 26 / 1.4MHz							
Channel	Modulation	RB		Horizontal		Vertical	
		Size	Offset	EIRP(dBm)	EIRP(W)	EIRP(dBm)	EIRP(W)
Lowest	QPSK	1	0	18.72	0.0745	19.79	0.0953
Middle		1	0	19.08	0.0809	20.33	0.1079
Highest		1	0	19.23	0.0838	20.64	0.1159
Lowest	16QAM	1	0	16.68	0.0466	17.67	0.0585
Middle		1	0	16.89	0.0489	18.01	0.0632
Highest		1	0	17.03	0.0505	18.47	0.0703
Limit	ERP < 7W			Result		PASS	

LTE Band 26/ 3MHz							
Channel	Modulation	RB		Horizontal		Vertical	
		Size	Offset	EIRP(dBm)	EIRP(W)	EIRP(dBm)	EIRP(W)
Lowest	QPSK	1	0	19.21	0.0834	20.25	0.1059
Middle		1	0	19.28	0.0847	20.48	0.1117
Highest		1	0	19.45	0.0881	20.87	0.1222
Lowest	16QAM	1	0	16.67	0.0465	17.66	0.0583
Middle		1	0	16.87	0.0486	18.05	0.0638
Highest		1	0	17.09	0.0512	18.41	0.0693
Limit	ERP < 7W			Result		PASS	

LTE Band 26 / 5MHz							
Channel	Modulation	RB		Horizontal		Vertical	
		Size	Offset	EIRP(dBm)	EIRP(W)	EIRP(dBm)	EIRP(W)
Lowest	QPSK	1	0	18.42	0.0695	19.31	0.0853
Middle		1	0	19.01	0.0796	20.28	0.1067
Highest		1	0	19.63	0.0918	20.76	0.1191
Lowest	16QAM	1	0	16.51	0.0448	17.45	0.0556
Middle		1	0	16.88	0.0488	18.01	0.0632
Highest		1	0	17.14	0.0518	18.49	0.0706
Limit	ERP < 7W			Result		PASS	



LTE Band 26 / 10MHz							
Channel	Modulation	RB		Horizontal		Vertical	
		Size	Offset	EIRP(dBm)	EIRP(W)	EIRP(dBm)	EIRP(W)
Lowest	QPSK	1	0	18.88	0.0773	19.70	0.0933
Middle		1	0	19.06	0.0805	20.23	0.1054
Highest		1	0	19.47	0.0885	20.83	0.1211
Lowest	16QAM	1	0	16.40	0.0437	17.51	0.0564
Middle		1	0	16.63	0.0460	17.89	0.0615
Highest		1	0	16.98	0.0499	18.23	0.0665
Limit	ERP < 7W			Result		PASS	

LTE Band 26 / 15MHz							
Channel	Modulation	RB		Horizontal		Vertical	
		Size	Offset	EIRP(dBm)	EIRP(W)	EIRP(dBm)	EIRP(W)
Lowest	QPSK	1	0	18.19	0.0659	19.17	0.0826
Middle		1	0	18.65	0.0733	19.68	0.0929
Highest		1	0	18.70	0.0741	19.84	0.0964
Lowest	16QAM	1	0	15.94	0.0393	17.02	0.0504
Middle		1	0	16.33	0.0430	17.30	0.0537
Highest		1	0	16.40	0.0437	17.49	0.0561
Limit	ERP < 7W			Result		PASS	



LTE Band 38 / 5MHz							
Channel	Modulation	RB		Horizontal		Vertical	
		Size	Offset	EIRP(dBm)	EIRP(W)	EIRP(dBm)	EIRP(W)
Lowest	QPSK	1	0	21.11	0.1291	22.11	0.1626
Middle		1	0	20.95	0.1245	21.71	0.1483
Highest		1	0	20.60	0.1148	21.33	0.1358
Lowest	16QAM	1	0	20.50	0.1122	21.51	0.1416
Middle		1	0	20.39	0.1094	21.17	0.1309
Highest		1	0	20.18	0.1042	21.03	0.1268
Limit	EIRP < 2W			Result		PASS	

LTE Band 38 / 10MHz							
Channel	Modulation	RB		Horizontal		Vertical	
		Size	Offset	EIRP(dBm)	EIRP(W)	EIRP(dBm)	EIRP(W)
Lowest	QPSK	1	0	20.92	0.1236	22.06	0.1607
Middle		1	0	20.87	0.1222	21.82	0.1521
Highest		1	0	20.38	0.1091	21.21	0.1321
Lowest	16QAM	1	0	21.02	0.1265	21.59	0.1442
Middle		1	0	20.82	0.1208	21.29	0.1346
Highest		1	0	20.55	0.1135	21.03	0.1268
Limit	EIRP < 2W			Result		PASS	

LTE Band 38 / 15MHz							
Channel	Modulation	RB		Horizontal		Vertical	
		Size	Offset	EIRP(dBm)	EIRP(W)	EIRP(dBm)	EIRP(W)
Lowest	QPSK	1	0	20.99	0.1256	22.12	0.1629
Middle		1	0	20.94	0.1242	21.92	0.1556
Highest		1	0	20.54	0.1132	21.42	0.1387
Lowest	16QAM	1	0	20.55	0.1135	21.32	0.1355
Middle		1	0	20.47	0.1114	21.12	0.1294
Highest		1	0	20.11	0.1026	20.67	0.1167
Limit	EIRP < 2W			Result		PASS	



LTE Band 38 / 20MHz							
Channel	Modulation	RB		Horizontal		Vertical	
		Size	Offset	EIRP(dBm)	EIRP(W)	EIRP(dBm)	EIRP(W)
Lowest	QPSK	1	0	20.92	0.1236	22.02	0.1592
Middle		1	0	20.93	0.1239	21.86	0.1535
Highest		1	0	20.48	0.1117	21.47	0.1403
Lowest	16QAM	1	0	20.44	0.1107	21.19	0.1315
Middle		1	0	20.44	0.1107	21.03	0.1268
Highest		1	0	20.13	0.1030	20.71	0.1178
Limit	EIRP < 2W			Result		PASS	



LTE Band 5 / 1.4MHz / QPSK / RB Size 1 Offset 0									
Channel	Frequency ( MHz )	ERP ( dBm )	Limit ( dBm )	Over Limit ( dB )	SPA Reading (dBm)	S.G. Power ( dBm )	TX Cable loss ( dB )	TX Antenna Gain (dBi)	Polarization (H/V)
Lowest	1648	-60.64	-13	-47.64	-71.99	-62.4	0.98	4.89	H
	2472	-59.62	-13	-46.62	-76.38	-61.5	1.28	5.32	H
	3296	-59.49	-13	-46.49	-76.98	-62.9	1.54	7.10	H
	1648	-60.74	-13	-47.74	-72.46	-62.5	0.98	4.89	V
	2472	-58.62	-13	-45.62	-76.3	-60.5	1.28	5.32	V
	3296	-58.09	-13	-45.09	-77	-61.5	1.54	7.10	V
Middle	1672	-59.22	-13	-46.22	-70.58	-60.9	0.99	4.82	H
	2507	-59.64	-13	-46.64	-76.27	-61.6	1.29	5.41	H
	3344	-59.49	-13	-46.49	-76.98	-63.1	1.56	7.31	H
	1672	-60.72	-13	-47.72	-72.95	-62.4	0.99	4.82	V
	2507	-57.94	-13	-44.94	-75.92	-59.9	1.29	5.41	V
	3344	-57.99	-13	-44.99	-77.01	-61.6	1.56	7.31	V
Highest	1696	-55.50	-13	-42.50	-67.37	-57.1	1.00	4.75	H
	2544	-59.42	-13	-46.42	-75.93	-61.4	1.30	5.44	H
	3391	-59.50	-13	-46.50	-77.27	-63.3	1.57	7.52	H
	1696	-57.50	-13	-44.50	-70.16	-59.1	1.00	4.75	V
	2544	-56.62	-13	-43.62	-75.06	-58.6	1.30	5.44	V
	3391	-58.60	-13	-45.60	-77.26	-62.4	1.57	7.52	V

LTE Band 5 / 3MHz / QPSK / RB Size 1 Offset 0									
Channel	Frequency ( MHz )	ERP ( dBm )	Limit ( dBm )	Over Limit ( dB )	SPA Reading (dBm)	S.G. Power ( dBm )	TX Cable loss ( dB )	TX Antenna Gain (dBi)	Polarization (H/V)
Lowest	1648	-60.74	-13	-47.74	-72.12	-62.5	0.98	4.89	H
	2472	-59.92	-13	-46.92	-76.27	-61.8	1.28	5.32	H
	3296	-59.39	-13	-46.39	-77.04	-62.8	1.54	7.10	H
	1648	-60.44	-13	-47.44	-72.34	-62.2	0.98	4.89	V
	2472	-58.62	-13	-45.62	-76.09	-60.5	1.28	5.32	V
	3296	-58.19	-13	-45.19	-76.82	-61.6	1.54	7.10	V
Middle	1672	-58.92	-13	-45.92	-70.19	-60.6	0.99	4.82	H
	2505	-59.74	-13	-46.74	-76.5	-61.7	1.29	5.40	H
	3340	-59.71	-13	-46.71	-77.22	-63.3	1.55	7.30	H
	1672	-60.92	-13	-47.92	-72.93	-62.6	0.99	4.82	V
	2505	-58.44	-13	-45.44	-76.36	-60.4	1.29	5.40	V
	3340	-58.01	-13	-45.01	-76.81	-61.6	1.55	7.30	V
Highest	1688	-56.47	-13	-43.47	-68.09	-58.1	1.00	4.77	H
	2538	-59.82	-13	-46.82	-76.44	-61.8	1.30	5.43	H
	3384	-59.73	-13	-46.73	-77.34	-63.5	1.57	7.49	H
	1688	-58.27	-13	-45.27	-70.41	-59.9	1.00	4.77	V
	2538	-58.22	-13	-45.22	-76.41	-60.2	1.30	5.43	V
	3384	-58.63	-13	-45.63	-77.15	-62.4	1.57	7.49	V

Remark: Spurious emissions within 30-1000MHz were found more than 20dB below limit line.



LTE Band 5 / 5MHz / QPSK / RB Size 1 Offset 0									
Channel	Frequency ( MHz )	ERP ( dBm )	Limit ( dBm )	Over Limit ( dB )	SPA Reading (dBm)	S.G. Power ( dBm )	TX Cable loss ( dB )	TX Antenna Gain (dBi)	Polarization (H/V)
Lowest	1648	-60.94	-13	-47.94	-72.04	-62.7	0.98	4.89	H
	2472	-59.22	-13	-46.22	-75.38	-61.1	1.28	5.32	H
	3296	-59.59	-13	-46.59	-77.02	-63	1.54	7.10	H
	1648	-60.74	-13	-47.74	-72.36	-62.5	0.98	4.89	V
	2472	-56.82	-13	-43.82	-74.69	-58.7	1.28	5.32	V
	3296	-57.89	-13	-44.89	-76.81	-61.3	1.54	7.10	V
Middle	1668	-59.51	-13	-46.51	-70.72	-61.2	0.99	4.83	H
	2502	-59.54	-13	-46.54	-76.22	-61.5	1.29	5.40	H
	3336	-59.52	-13	-46.52	-77.2	-63.1	1.55	7.28	H
	1668	-60.11	-13	-47.11	-72.14	-61.8	0.99	4.83	V
	2502	-58.44	-13	-45.44	-76.26	-60.4	1.29	5.40	V
	3336	-58.12	-13	-45.12	-77.09	-61.7	1.55	7.28	V
Highest	1688	-57.47	-13	-44.47	-69	-59.1	1.00	4.77	H
	2532	-59.93	-13	-46.93	-76.56	-61.9	1.30	5.43	H
	3376	-59.56	-13	-46.56	-77.22	-63.3	1.57	7.45	H
	1688	-58.07	-13	-45.07	-70.08	-59.7	1.00	4.77	V
	2532	-58.33	-13	-45.33	-76.45	-60.3	1.30	5.43	V
	3376	-57.76	-13	-44.76	-76.76	-61.5	1.57	7.45	V

LTE Band 5 / 10MHz / QPSK / RB Size 1 Offset 0									
Channel	Frequency ( MHz )	ERP ( dBm )	Limit ( dBm )	Over Limit ( dB )	SPA Reading (dBm)	S.G. Power ( dBm )	TX Cable loss ( dB )	TX Antenna Gain (dBi)	Polarization (H/V)
Lowest	1648	-60.64	-13	-47.64	-71.82	-62.4	0.98	4.89	H
	2472	-59.52	-13	-46.52	-75.99	-61.4	1.28	5.32	H
	3296	-59.69	-13	-46.69	-77.21	-63.1	1.54	7.10	H
	1648	-60.04	-13	-47.04	-71.9	-61.8	0.98	4.89	V
	2472	-58.72	-13	-45.72	-76.36	-60.6	1.28	5.32	V
	3296	-57.99	-13	-44.99	-76.98	-61.4	1.54	7.10	V
Middle	1664	-59.09	-13	-46.09	-70.4	-60.8	0.98	4.84	H
	2495	-58.35	-13	-45.35	-75.07	-60.3	1.29	5.39	H
	3326	-59.67	-13	-46.67	-77.16	-63.2	1.55	7.23	H
	1664	-60.19	-13	-47.19	-72.28	-61.9	0.98	4.84	V
	2495	-58.15	-13	-45.15	-75.82	-60.1	1.29	5.39	V
	3326	-58.17	-13	-45.17	-77.15	-61.7	1.55	7.23	V
Highest	1680	-57.95	-13	-44.95	-69.37	-59.6	0.99	4.80	H
	2517	-59.73	-13	-46.73	-76.36	-61.7	1.30	5.41	H
	3356	-59.94	-13	-46.94	-77.26	-63.6	1.56	7.37	H
	1680	-59.85	-13	-46.85	-71.76	-61.5	0.99	4.80	V
	2517	-58.33	-13	-45.33	-76.21	-60.3	1.30	5.41	V
	3356	-57.94	-13	-44.94	-77	-61.6	1.56	7.37	V

Remark: Spurious emissions within 30-1000MHz were found more than 20dB below limit line.



LTE Band 13 / 5MHz / QPSK / RB Size 1 Offset 0									
Channel	Frequency ( MHz )	ERP ( dBm )	Limit ( dBm )	Over Limit ( dB )	SPA Reading (dBm)	S.G. Power ( dBm )	TX Cable loss ( dB )	TX Antenna Gain (dBi)	Polarization (H/V)
Lowest	1554	-63.64	-13	-50.64	-74.23	-65.70	0.94	5.15	H
	2331	-60.79	-13	-47.79	-75.17	-62.30	1.24	4.89	H
	3108	-59.56	-13	-46.56	-76.77	-62.20	1.48	6.28	H
	1554	-63.74	-13	-50.74	-74.75	-65.80	0.94	5.15	V
	2331	-59.59	-13	-46.59	-75.97	-61.10	1.24	4.89	V
	3108	-58.06	-13	-45.06	-76.76	-60.70	1.48	6.28	V
Middle	1559	-63.05	-42.15	-20.90	-73.47	-65.10	0.94	5.13	H
	2338	-58.08	-13	-45.08	-72.59	-59.60	1.24	4.91	H
	3118	-59.52	-13	-46.52	-76.76	-62.20	1.48	6.32	H
	1559	-63.75	-42.15	-21.60	-74.68	-65.80	0.94	5.13	V
	2338	-57.58	-13	-44.58	-73.92	-59.10	1.24	4.91	V
	3118	-57.72	-13	-44.72	-76.59	-60.40	1.48	6.32	V
Highest	1564	-63.37	-42.15	-21.22	-73.59	-65.40	0.94	5.12	H
	2346	-59.05	-13	-46.05	-73.87	-60.60	1.24	4.94	H
	3128	-59.37	-13	-46.37	-76.53	-62.10	1.49	6.36	H
	1564	-63.07	-42.15	-20.92	-74.24	-65.10	0.94	5.12	V
	2346	-58.95	-13	-45.95	-75.00	-60.50	1.24	4.94	V
	3128	-57.47	-13	-44.47	-76.35	-60.20	1.49	6.36	V

LTE Band 13 / 10MHz / QPSK / RB Size 1 Offset 0									
Channel	Frequency ( MHz )	ERP ( dBm )	Limit ( dBm )	Over Limit ( dB )	SPA Reading (dBm)	S.G. Power ( dBm )	TX Cable loss ( dB )	TX Antenna Gain (dBi)	Polarization (H/V)
Middle	1554	-62.84	-13	-49.84	-73.27	-64.9	0.94	5.15	H
	2331	-59.19	-13	-46.19	-73.59	-60.7	1.24	4.89	H
	3108	-59.46	-13	-46.46	-76.66	-62.1	1.48	6.28	H
	1554	-63.24	-13	-50.24	-74.54	-65.3	0.94	5.15	V
	2331	-59.69	-13	-46.69	-75.87	-61.2	1.24	4.89	V
	3108	-57.76	-13	-44.76	-76.43	-60.4	1.48	6.28	V

Remark: Spurious emissions within 30-1000MHz were found more than 20dB below limit line.



LTE Band 25 / 1.4MHz / QPSK / RB Size 1 Offset 0									
Channel	Frequency ( MHz )	EIRP ( dBm )	Limit ( dBm )	Over Limit ( dB )	SPA Reading (dBm)	S.G. Power ( dBm )	TX Cable loss ( dB )	TX Antenna Gain (dBi)	Polarization (H/V)
Lowest	3700	-58.63	-13	-45.63	-77.95	-65.2	1.67	8.24	H
	5550	-53.73	-13	-40.73	-78.29	-60.8	2.65	9.72	H
	7400	-52.26	-13	-39.26	-78.91	-61.4	2.46	11.60	H
	3700	-57.73	-13	-44.73	-77.74	-64.3	1.67	8.24	V
	5550	-52.53	-13	-39.53	-78.52	-59.6	2.65	9.72	V
	7400	-50.96	-13	-37.96	-79.06	-60.1	2.46	11.60	V
Middle	3759	-57.87	-13	-44.87	-77.59	-64.5	1.69	8.31	H
	5638	-53.85	-13	-40.85	-78.6	-60.9	2.70	9.76	H
	7517	-52.01	-13	-39.01	-79.02	-61.4	2.42	11.81	H
	3759	-57.17	-13	-44.17	-77.64	-63.8	1.69	8.31	V
	5638	-52.95	-13	-39.95	-78.3	-60	2.70	9.76	V
	7517	-50.51	-13	-37.51	-79.06	-59.9	2.42	11.81	V
Highest	3827	-56.71	-13	-43.71	-77.21	-63.4	1.71	8.39	H
	5741	-53.67	-13	-40.67	-78.39	-60.7	2.76	9.80	H
	7654	-50.99	-13	-37.99	-78.5	-60.5	2.38	11.89	H
	3827	-56.11	-13	-43.11	-77.17	-62.8	1.71	8.39	V
	5741	-52.67	-13	-39.67	-78.31	-59.7	2.76	9.80	V
	7654	-49.69	-13	-36.69	-78.68	-59.2	2.38	11.89	V

LTE Band 25 / 3MHz / QPSK / RB Size 1 Offset 0									
Channel	Frequency ( MHz )	EIRP ( dBm )	Limit ( dBm )	Over Limit ( dB )	SPA Reading (dBm)	S.G. Power ( dBm )	TX Cable loss ( dB )	TX Antenna Gain (dBi)	Polarization (H/V)
Lowest	3703	-58.72	-13	-45.72	-77.93	-65.3	1.67	8.24	H
	5554	-54.33	-13	-41.33	-78.8	-61.4	2.66	9.72	H
	7405	-52.75	-13	-39.75	-79.01	-61.9	2.46	11.61	H
	3703	-57.72	-13	-44.72	-77.75	-64.3	1.67	8.24	V
	5554	-52.73	-13	-39.73	-78.25	-59.8	2.66	9.72	V
	7405	-50.55	-13	-37.55	-78.68	-59.7	2.46	11.61	V
Middle	3756	-57.74	-13	-44.74	-77.22	-64.36	1.68	8.31	H
	5636	-53.83	-13	-40.83	-78.33	-60.88	2.70	9.75	H
	7514	-51.95	-13	-38.95	-78.81	-61.33	2.42	11.81	H
	3756	-57.39	-13	-44.39	-77.42	-64.01	1.68	8.31	V
	5636	-53.03	-13	-40.03	-78.53	-60.08	2.70	9.75	V
	7514	-50.54	-13	-37.54	-78.96	-59.92	2.42	11.81	V
Highest	3827	-56.51	-13	-43.51	-77.35	-63.2	1.71	8.39	H
	5740	-55.87	-13	-42.87	-78.58	-62.9	2.76	9.80	H
	7654	-51.39	-13	-38.39	-78.81	-60.9	2.38	11.89	H
	3827	-56.41	-13	-43.41	-77.39	-63.1	1.71	8.39	V
	5740	-53.07	-13	-40.07	-78.73	-60.1	2.76	9.80	V
	7654	-49.59	-13	-36.59	-78.62	-59.1	2.38	11.89	V

Remark: Spurious emissions within 30-1000MHz were found more than 20dB below limit line.



LTE Band 25 / 5MHz / QPSK / RB Size 1 Offset 0									
Channel	Frequency ( MHz )	EIRP ( dBm )	Limit ( dBm )	Over Limit ( dB )	SPA Reading (dBm)	S.G. Power ( dBm )	TX Cable loss ( dB )	TX Antenna Gain (dBi)	Polarization (H/V)
Lowest	3700	-58.54	-13	-45.54	-77.66	-65.11	1.67	8.24	H
	5550	-53.36	-13	-40.36	-78.07	-60.43	2.65	9.72	H
	7400	-52.37	-13	-39.37	-78.9	-61.51	2.46	11.60	H
	3700	-57.72	-13	-44.72	-77.85	-64.29	1.67	8.24	V
	5550	-52.15	-13	-39.15	-78.42	-59.22	2.65	9.72	V
	7400	-50.88	-13	-37.88	-79.13	-60.02	2.46	11.60	V
Middle	3756	-58.04	-13	-45.04	-77.44	-64.66	1.68	8.31	H
	5633	-53.94	-13	-40.94	-78.49	-60.99	2.70	9.75	H
	7510	-51.70	-13	-38.70	-78.56	-61.08	2.43	11.81	H
	3756	-57.39	-13	-44.39	-77.5	-64.01	1.68	8.31	V
	5633	-52.76	-13	-39.76	-78.54	-59.81	2.70	9.75	V
	7510	-50.49	-13	-37.49	-78.96	-59.87	2.43	11.81	V
Highest	3820	-57.44	-13	-44.44	-78.3	-64.12	1.70	8.38	H
	5728	-54.89	-13	-41.89	-79.48	-61.92	2.76	9.79	H
	7640	-52.49	-13	-39.49	-79.81	-61.99	2.38	11.88	H
	3820	-56.97	-13	-43.97	-78.23	-63.65	1.70	8.38	V
	5728	-54.08	-13	-41.08	-79.47	-61.11	2.76	9.79	V
	7640	-50.61	-13	-37.61	-79.84	-60.11	2.38	11.88	V

LTE Band 25 / 10MHz / QPSK / RB Size 1 Offset 0									
Channel	Frequency ( MHz )	EIRP ( dBm )	Limit ( dBm )	Over Limit ( dB )	SPA Reading (dBm)	S.G. Power ( dBm )	TX Cable loss ( dB )	TX Antenna Gain (dBi)	Polarization (H/V)
Lowest	3700	-58.74	-13	-45.74	-77.87	-65.31	1.67	8.24	H
	5550	-53.95	-13	-40.95	-78.5	-61.02	2.65	9.72	H
	7400	-52.57	-13	-39.57	-78.75	-61.71	2.46	11.60	H
	3700	-57.74	-13	-44.74	-77.9	-64.31	1.67	8.24	V
	5550	-52.54	-13	-39.54	-78.31	-59.61	2.65	9.72	V
	7400	-50.67	-13	-37.67	-78.73	-59.81	2.46	11.60	V
Middle	3748	-59.04	-13	-46.04	-78.43	-65.66	1.68	8.30	H
	5624	-54.76	-13	-41.76	-79.36	-61.81	2.70	9.75	H
	7504	-53.44	-13	-40.44	-80.01	-62.81	2.43	11.80	H
	3748	-58.39	-13	-45.39	-78.54	-65.01	1.68	8.30	V
	5624	-53.97	-13	-40.97	-79.47	-61.02	2.70	9.75	V
	7504	-51.51	-13	-38.51	-79.97	-60.88	2.43	11.80	V
Highest	3812	-56.35	-13	-43.35	-77.02	-63.02	1.70	8.37	H
	5715	-53.77	-13	-40.77	-78.46	-60.81	2.75	9.79	H
	7620	-51.73	-13	-38.73	-79.04	-61.21	2.39	11.87	H
	3810	-56.35	-13	-43.35	-77.36	-63.02	1.70	8.37	V
	5715	-52.98	-13	-39.98	-78.51	-60.02	2.75	9.79	V
	7620	-49.88	-13	-36.88	-79.11	-59.36	2.39	11.87	V

Remark: Spurious emissions within 30-1000MHz were found more than 20dB below limit line.



LTE Band 25 / 15 MHz / QPSK / RB Size 1 Offset 0									
Channel	Frequency ( MHz )	EIRP ( dBm )	Limit ( dBm )	Over Limit ( dB )	SPA Reading (dBm)	S.G. Power ( dBm )	TX Cable loss ( dB )	TX Antenna Gain (dBi)	Polarization (H/V)
Lowest	3700	-58.72	-13	-45.72	-77.88	-65.29	1.67	8.24	H
	5550	-54.01	-13	-41.01	-78.57	-61.08	2.65	9.72	H
	7400	-52.78	-13	-39.78	-79.02	-61.92	2.46	11.60	H
	3700	-57.82	-13	-44.82	-78	-64.39	1.67	8.24	V
	5550	-51.99	-13	-38.99	-78.78	-59.06	2.65	9.72	V
	7400	-50.94	-13	-37.94	-78.93	-60.08	2.46	11.60	V
Middle	3742	-58.01	-13	-45.01	-77.41	-64.62	1.68	8.29	H
	5618	-53.78	-13	-40.78	-78.32	-60.83	2.69	9.75	H
	7488	-52.08	-13	-39.08	-78.8	-61.42	2.43	11.78	H
	3742	-57.52	-13	-44.52	-77.7	-64.13	1.68	8.29	V
	5618	-52.81	-13	-39.81	-78.3	-59.86	2.69	9.75	V
	7488	-50.78	-13	-37.78	-79.23	-60.12	2.43	11.78	V
Highest	3798	-56.76	-13	-43.76	-77.4	-63.42	1.70	8.36	H
	5702	-51.29	-13	-38.29	-76.01	-58.33	2.74	9.78	H
	7600	-51.87	-13	-38.87	-79.45	-61.33	2.40	11.86	H
	3798	-56.36	-13	-43.36	-77.33	-63.02	1.70	8.36	V
	5702	-53.07	-13	-40.07	-78.62	-60.11	2.74	9.78	V
	7600	-49.95	-13	-36.95	-79.24	-59.41	2.40	11.86	V

LTE Band 25 / 20MHz / QPSK / RB Size 1 Offset 0									
Channel	Frequency ( MHz )	EIRP ( dBm )	Limit ( dBm )	Over Limit ( dB )	SPA Reading (dBm)	S.G. Power ( dBm )	TX Cable loss ( dB )	TX Antenna Gain (dBi)	Polarization (H/V)
Lowest	3700	-58.82	-13	-45.82	-78	-65.39	1.67	8.24	H
	5550	-53.95	-13	-40.95	-78.51	-61.02	2.65	9.72	H
	7400	-52.37	-13	-39.37	-78.93	-61.51	2.46	11.60	H
	3700	-57.54	-13	-44.54	-77.67	-64.11	1.67	8.24	V
	5550	-52.95	-13	-39.95	-78.75	-60.02	2.65	9.72	V
	7400	-50.97	-13	-37.97	-78.96	-60.11	2.46	11.60	V
Middle	3742	-58.51	-13	-45.51	-77.69	-65.12	1.68	8.29	H
	5611	-53.75	-13	-40.75	-78.29	-60.81	2.69	9.74	H
	7480	-52.61	-13	-39.61	-79.09	-61.93	2.44	11.76	H
	3742	-57.27	-13	-44.27	-77.39	-63.88	1.68	8.29	V
	5611	-52.97	-13	-39.97	-78.51	-60.03	2.69	9.74	V
	7480	-50.81	-13	-37.81	-79.04	-60.13	2.44	11.76	V
Highest	3791	-56.86	-13	-43.86	-77.14	-63.51	1.70	8.35	H
	5685	-53.99	-13	-40.99	-78.56	-61.03	2.73	9.77	H
	7580	-51.85	-13	-38.85	-79.31	-61.29	2.40	11.85	H
	3791	-56.27	-13	-43.27	-77.08	-62.92	1.70	8.35	V
	5685	-51.88	-13	-38.88	-77.5	-58.92	2.73	9.77	V
	7580	-50.22	-13	-37.22	-79.42	-59.66	2.40	11.85	V

Remark: Spurious emissions within 30-1000MHz were found more than 20dB below limit line.



LTE Band 26 / 1.4MHz / QPSK / RB Size 1 Offset 0									
Channel	Frequency ( MHz )	ERP ( dBm )	Limit ( dBm )	Over Limit ( dB )	SPA Reading (dBm)	S.G. Power ( dBm )	TX Cable loss ( dB )	TX Antenna Gain (dBi)	Polarization (H/V)
Lowest	1648	-60.03	-13	-47.03	-70.94	-61.79	0.98	4.89	H
	2472	-60.28	-13	-47.28	-76.23	-62.16	1.28	5.32	H
	3296	-60.31	-13	-47.31	-76.82	-63.72	1.54	7.10	H
	1648	-61.10	-13	-48.10	-72.22	-62.86	0.98	4.89	V
	2472	-58.79	-13	-45.79	-76.18	-60.67	1.28	5.32	V
	3296	-58.50	-13	-45.50	-77.02	-61.91	1.54	7.10	V
Middle	1672	-58.94	-13	-45.94	-69.92	-60.62	0.99	4.82	H
	2504	-60.42	-13	-47.42	-76.53	-62.38	1.29	5.40	H
	3344	-60.03	-13	-47.03	-77.07	-63.64	1.56	7.31	H
	1672	-60.77	-13	-47.77	-72.49	-62.45	0.99	4.82	V
	2504	-58.55	-13	-45.55	-76.19	-60.51	1.29	5.40	V
	3344	-58.75	-13	-45.75	-77.07	-62.36	1.56	7.31	V
Highest	1696	-54.04	-13	-41.04	-64.9	-55.64	1.00	4.75	H
	2544	-59.97	-13	-46.97	-76.32	-61.95	1.30	5.44	H
	3392	-59.75	-13	-46.75	-77.29	-63.55	1.57	7.52	H
	1696	-55.58	-13	-42.58	-67.59	-57.18	1.00	4.75	V
	2544	-58.29	-13	-45.29	-75.99	-60.27	1.30	5.44	V
	3392	-58.82	-13	-45.82	-77.28	-62.62	1.57	7.52	V

LTE Band 26 / 3MHz / QPSK / RB Size 1 Offset 0									
Channel	Frequency ( MHz )	ERP ( dBm )	Limit ( dBm )	Over Limit ( dB )	SPA Reading (dBm)	S.G. Power ( dBm )	TX Cable loss ( dB )	TX Antenna Gain (dBi)	Polarization (H/V)
Lowest	1648	-61.10	-13	-48.10	-71.68	-62.86	0.98	4.89	H
	2472	-60.25	-13	-47.25	-76.11	-62.13	1.28	5.32	H
	3296	-59.92	-13	-46.92	-76.88	-63.33	1.54	7.10	H
	1648	-61.61	-13	-48.61	-73.28	-63.37	0.98	4.89	V
	2472	-58.96	-13	-45.96	-76.35	-60.84	1.28	5.32	V
	3296	-58.76	-13	-45.76	-77.18	-62.17	1.54	7.10	V
Middle	1672	-59.06	-13	-46.06	-70.04	-60.74	0.99	4.82	H
	2504	-60.26	-13	-47.26	-76.38	-62.22	1.29	5.40	H
	3336	-60.36	-13	-47.36	-77.1	-63.94	1.55	7.28	H
	1672	-61.63	-13	-48.63	-73.07	-63.31	0.99	4.82	V
	2504	-58.75	-13	-45.75	-76.26	-60.71	1.29	5.40	V
	3336	-58.80	-13	-45.80	-76.93	-62.38	1.55	7.28	V
Highest	1696	-55.54	-13	-42.54	-66.56	-57.14	1.00	4.75	H
	2544	-59.97	-13	-46.97	-76.32	-61.95	1.30	5.44	H
	3392	-59.87	-13	-46.87	-77.28	-63.67	1.57	7.52	H
	1696	-57.14	-13	-44.14	-68.98	-58.74	1.00	4.75	V
	2544	-58.59	-13	-45.59	-76.04	-60.57	1.30	5.44	V
	3392	-58.49	-13	-45.49	-76.94	-62.29	1.57	7.52	V

Remark: Spurious emissions within 30-1000MHz were found more than 20dB below limit line.



LTE Band 26 / 5MHz / QPSK / RB Size 1 Offset 0									
Channel	Frequency ( MHz )	ERP ( dBm )	Limit ( dBm )	Over Limit ( dB )	SPA Reading (dBm)	S.G. Power ( dBm )	TX Cable loss ( dB )	TX Antenna Gain (dBi)	Polarization (H/V)
Lowest	1648	-60.83	-13	-47.83	-71.65	-62.59	0.98	4.89	H
	2472	-60.44	-13	-47.44	-76.26	-62.32	1.28	5.32	H
	3296	-59.78	-13	-46.78	-76.74	-63.19	1.54	7.10	H
	1648	-60.01	-13	-47.01	-71.68	-61.77	0.98	4.89	V
	2472	-58.48	-13	-45.48	-75.93	-60.36	1.28	5.32	V
	3296	-58.77	-13	-45.77	-77.19	-62.18	1.54	7.10	V
Middle	1672	-60.26	-13	-47.26	-70.79	-61.94	0.99	4.82	H
	2504	-59.67	-13	-46.67	-76.06	-61.63	1.29	5.40	H
	3336	-60.35	-13	-47.35	-77	-63.93	1.55	7.28	H
	1672	-62.81	-13	-49.81	-74.44	-64.49	0.99	4.82	V
	2504	-58.92	-13	-45.92	-76.31	-60.88	1.29	5.40	V
	3336	-58.38	-13	-45.38	-77.06	-61.96	1.55	7.28	V
Highest	1688	-55.49	-13	-42.49	-66.47	-57.12	1.00	4.77	H
	2536	-60.50	-13	-47.50	-76.49	-62.48	1.30	5.43	H
	3376	-60.13	-13	-47.13	-77.33	-63.87	1.57	7.45	H
	1688	-58.48	-13	-45.48	-70.12	-60.11	1.00	4.77	V
	2536	-58.69	-13	-45.69	-76.32	-60.67	1.30	5.43	V
	3376	-58.23	-13	-45.23	-77.04	-61.97	1.57	7.45	V

LTE Band 26/ 10MHz / QPSK / RB Size 1 Offset 0									
Channel	Frequency ( MHz )	ERP ( dBm )	Limit ( dBm )	Over Limit ( dB )	SPA Reading (dBm)	S.G. Power ( dBm )	TX Cable loss ( dB )	TX Antenna Gain (dBi)	Polarization (H/V)
Lowest	1656	-61.11	-13	-48.11	-71.99	-62.84	0.98	4.86	H
	2488	-60.23	-13	-47.23	-76.28	-62.16	1.29	5.36	H
	3312	-60.01	-13	-47.01	-76.98	-63.49	1.55	7.17	H
	1656	-62.18	-13	-49.18	-73.73	-63.91	0.98	4.86	V
	2488	-57.85	-13	-44.85	-75.07	-59.78	1.29	5.36	V
	3312	-58.51	-13	-45.51	-77.09	-61.99	1.55	7.17	V
Middle	1672	-56.80	-13	-43.80	-67.78	-58.48	0.99	4.82	H
	2512	-55.76	-13	-42.76	-72.07	-57.73	1.29	5.41	H
	3344	-59.88	-13	-46.88	-77.1	-63.49	1.56	7.31	H
	1672	-60.71	-13	-47.71	-72.24	-62.39	0.99	4.82	V
	2512	-53.66	-13	-40.66	-70.99	-55.63	1.29	5.41	V
	3344	-58.15	-13	-45.15	-76.82	-61.76	1.56	7.31	V
Highest	1688	-56.83	-13	-43.83	-67.85	-58.46	1.00	4.77	H
	2528	-60.16	-13	-47.16	-76.48	-62.13	1.30	5.42	H
	3376	-59.67	-13	-46.67	-76.85	-63.41	1.57	7.45	H
	1688	-59.50	-13	-46.50	-71.19	-61.13	1.00	4.77	V
	2528	-56.26	-13	-43.26	-73.84	-58.23	1.30	5.42	V
	3376	-58.82	-13	-45.82	-77.26	-62.56	1.57	7.45	V

Remark: Spurious emissions within 30-1000MHz were found more than 20dB below limit line.



LTE Band 26 / 15 MHz / QPSK / RB Size 1 Offset 0									
Channel	Frequency ( MHz )	ERP ( dBm )	Limit ( dBm )	Over Limit ( dB )	SPA Reading (dBm)	S.G. Power ( dBm )	TX Cable loss ( dB )	TX Antenna Gain (dBi)	Polarization (H/V)
Lowest	1648	-60.73	-13	-47.73	-71.55	-62.49	0.98	4.89	H
	2472	-60.33	-13	-47.33	-76.3	-62.21	1.28	5.32	H
	3296	-60.03	-13	-47.03	-76.99	-63.44	1.54	7.10	H
	1648	-60.73	-13	-47.73	-72.35	-62.49	0.98	4.89	V
	2472	-57.93	-13	-44.93	-75.05	-59.81	1.28	5.32	V
	3296	-59.73	-13	-46.73	-77.05	-63.14	1.54	7.10	V
Middle	1656	-60.58	-13	-47.58	-70.88	-62.31	0.98	4.86	H
	2488	-60.24	-13	-47.24	-76.15	-62.17	1.29	5.36	H
	3320	-60.03	-13	-47.03	-77.12	-63.54	1.55	7.21	H
	1656	-61.95	-13	-48.95	-73.59	-63.68	0.98	4.86	V
	2488	-57.65	-13	-44.65	-74.84	-59.58	1.29	5.36	V
	3320	-58.80	-13	-45.80	-77.23	-62.31	1.55	7.21	V
Highest	1672	-59.03	-13	-46.03	-69.47	-60.71	0.99	4.82	H
	2504	-59.89	-13	-46.89	-76.55	-61.85	1.29	5.40	H
	3336	-60.35	-13	-47.35	-77	-63.93	1.55	7.28	H
	1672	-60.88	-13	-47.88	-72.6	-62.56	0.99	4.82	V
	2504	-56.57	-13	-43.57	-74.3	-58.53	1.29	5.40	V
	3336	-58.60	-13	-45.60	-76.91	-62.18	1.55	7.28	V



LTE Band 38 / 5MHz / QPSK / RB Size 1 Offset 0									
Channel	Frequency ( MHz )	EIRP ( dBm )	Limit ( dBm )	Over Limit ( dB )	SPA Reading (dBm)	S.G. Power ( dBm )	TX Cable loss ( dB )	TX Antenna Gain (dBi)	Polarization (H/V)
Lowest	5140	-54.82	-25	-29.82	-78.09	-62.1	2.42	9.70	H
	7710	-50.84	-25	-25.84	-77.98	-60.4	2.36	11.93	H
	10280	-50.48	-25	-25.48	-79.12	-60.1	2.69	12.31	H
	5140	-53.62	-25	-28.62	-78.14	-60.9	2.42	9.70	V
	7710	-49.34	-25	-24.34	-78.32	-58.9	2.36	11.93	V
	10280	-47.98	-25	-22.98	-79.2	-57.6	2.69	12.31	V
Middle	5185	-54.94	-25	-29.94	-78.51	-62.2	2.44	9.70	H
	7778	-51.57	-25	-26.57	-79.01	-61.2	2.34	11.97	H
	10370	-50.95	-25	-25.95	-80.05	-60.6	2.69	12.35	H
	5185	-53.84	-25	-28.84	-78.41	-61.1	2.44	9.70	V
	7778	-50.37	-25	-25.37	-78.47	-60	2.34	11.97	V
	10370	-48.15	-25	-23.15	-79.65	-57.8	2.69	12.35	V
Highest	5230	-54.07	-25	-29.07	-77.9	-61.3	2.47	9.70	H
	7845	-51.01	-25	-26.01	-78.4	-60.7	2.32	12.01	H
	10460	-50.51	-25	-25.51	-79.63	-60.2	2.69	12.38	H
	5230	-53.17	-25	-28.17	-77.79	-60.4	2.47	9.70	V
	7545	-49.39	-25	-24.39	-78.11	-58.8	2.41	11.83	V
	10460	-47.61	-25	-22.61	-79.61	-57.3	2.69	12.38	V

LTE Band 38 / 10MHz / QPSK / RB Size 1 Offset 0									
Channel	Frequency ( MHz )	EIRP ( dBm )	Limit ( dBm )	Over Limit ( dB )	SPA Reading (dBm)	S.G. Power ( dBm )	TX Cable loss ( dB )	TX Antenna Gain (dBi)	Polarization (H/V)
Lowest	5140	-53.82	-25	-28.82	-78.41	-61.1	2.42	9.70	H
	7710	-51.24	-25	-26.24	-78.68	-60.8	2.36	11.93	H
	10280	-51.28	-25	-26.28	-79.61	-60.9	2.69	12.31	H
	5140	-54.22	-25	-29.22	-78.72	-61.5	2.42	9.70	V
	7710	-49.64	-25	-24.64	-78.72	-59.2	2.36	11.93	V
	10280	-48.18	-25	-23.18	-79.54	-57.8	2.69	12.31	V
Middle	5180	-54.34	-25	-29.34	-77.8	-61.6	2.44	9.70	H
	7770	-50.68	-25	-25.68	-78.19	-60.3	2.34	11.96	H
	10360	-50.65	-25	-25.65	-79.72	-60.3	2.69	12.34	H
	5180	-53.44	-25	-28.44	-77.63	-60.7	2.44	9.70	V
	7770	-49.28	-25	-24.28	-77.96	-58.9	2.34	11.96	V
	10360	-48.15	-25	-23.15	-79.65	-57.8	2.69	12.34	V
Highest	5220	-54.96	-25	-29.96	-78.62	-62.2	2.46	9.70	H
	7830	-52.02	-25	-27.02	-79.03	-61.7	2.32	12.00	H
	10440	-50.22	-25	-25.22	-79.45	-59.9	2.69	12.38	H
	5220	-53.86	-25	-28.86	-78.7	-61.1	2.46	9.70	V
	7830	-50.42	-25	-25.42	-78.81	-60.1	2.32	12.00	V
	10440	-48.02	-25	-23.02	-79.89	-57.7	2.69	12.38	V

Remark: Spurious emissions within 30-1000MHz were found more than 20dB below limit line.



LTE Band 38 / 15 MHz / QPSK / RB Size 1 Offset 0									
Channel	Frequency ( MHz )	EIRP ( dBm )	Limit ( dBm )	Over Limit ( dB )	SPA Reading (dBm)	S.G. Power ( dBm )	TX Cable loss ( dB )	TX Antenna Gain (dBi)	Polarization (H/V)
Lowest	5140	-54.52	-25	-29.52	-77.92	-61.8	2.42	9.70	H
	7710	-50.64	-25	-25.64	-78.11	-60.2	2.36	11.93	H
	10280	-50.38	-25	-25.38	-79.21	-60	2.69	12.31	H
	5140	-53.22	-25	-28.22	-77.84	-60.5	2.42	9.70	V
	7710	-48.84	-25	-23.84	-77.89	-58.4	2.36	11.93	V
	10280	-48.18	-25	-23.18	-79.26	-57.8	2.69	12.31	V
Middle	5175	-54.84	-25	-29.84	78.22	-62.1	2.44	9.70	H
	7763	-50.99	-25	-25.99	-78.39	-60.6	2.34	11.96	H
	10350	-50.75	-25	-25.75	-79.71	-60.4	2.69	12.34	H
	5175	-53.44	-25	-28.44	-78.17	-60.7	2.44	9.70	V
	7763	-49.59	-25	-24.59	-78.19	-59.2	2.34	11.96	V
	10350	-47.75	-25	-22.75	-79.4	-57.4	2.69	12.34	V
Highest	5210	-54.56	-25	-29.56	-78.16	-61.8	2.46	9.70	H
	7815	-51.04	-25	-26.04	-78.36	-60.7	2.33	11.99	H
	10420	-50.63	-25	-25.63	-79.42	-60.3	2.69	12.37	H
	5210	-53.46	-25	-28.46	-78.11	-60.7	2.46	9.70	V
	7815	-49.04	-25	-24.04	-77.72	-58.7	2.33	11.99	V
	10420	-47.83	-25	-22.83	-79.51	-57.5	2.69	12.37	V

LTE Band 38 / 20MHz / QPSK / RB Size 1 Offset 0									
Channel	Frequency ( MHz )	EIRP ( dBm )	Limit ( dBm )	Over Limit ( dB )	SPA Reading (dBm)	S.G. Power ( dBm )	TX Cable loss ( dB )	TX Antenna Gain (dBi)	Polarization (H/V)
Lowest	5140	-53.92	-25	-28.92	-77.42	-61.2	2.42	9.70	H
	7710	-50.94	-25	-25.94	-78.1	-60.5	2.36	11.93	H
	10280	-50.68	-25	-25.68	-79.38	-60.3	2.69	12.31	H
	5140	-53.22	-25	-28.22	-77.86	-60.5	2.42	9.70	V
	7710	-49.04	-25	-24.04	-78.1	-58.6	2.36	11.93	V
	10280	-47.78	-25	-22.78	-79.04	-57.4	2.69	12.31	V
Middle	5170	-54.43	-25	-29.43	-77.95	-61.7	2.43	9.70	H
	7755	-50.99	-25	-25.99	-78.03	-60.6	2.35	11.95	H
	10340	-51.16	-25	-26.16	-80.02	-60.8	2.69	12.34	H
	5170	-53.33	-25	-28.33	-77.98	-60.6	2.43	9.70	V
	7755	-49.09	-25	-24.09	-77.95	-58.7	2.35	11.95	V
	10340	-48.36	-25	-23.36	-79.55	-58	2.69	12.34	V
Highest	5202	-55.66	-25	-30.66	-78.49	-62.91	2.45	9.70	H
	7800	-52.48	-25	-27.48	-79.19	-62.13	2.33	11.98	H
	10404	-50.64	-25	-25.64	-79.67	-60.31	2.69	12.36	H
	5202	-54.44	-25	-29.44	-78.37	-61.69	2.45	9.70	V
	7800	-50.51	-25	-25.51	-79	-60.16	2.33	11.98	V
	10404	-48.19	-25	-23.19	-79.8	-57.86	2.69	12.36	V

Remark: Spurious emissions within 30-1000MHz were found more than 20dB below limit line.



## **Appendix C. Original Report**

Please refer to Sporton report number FG541573B as below.



# FCC RF Test Report

**APPLICANT** : Motorola Mobility, LLC  
**EQUIPMENT** : Mobile Cellular Phone  
**BRAND NAME** : Motorola  
**MODEL NAME** : 5137  
**FCC ID** : IHDT56UC2  
**STANDARD** : 47 CFR Part 2, 22(H), 24(E), 27  
**CLASSIFICATION** : PCS Licensed Transmitter Held to Ear (PCE)

The product was received on Apr. 15, 2015 and completely tested on May 20, 2015. We, SPORTON INTERNATIONAL INC., would like to declare that the tested sample has been evaluated in accordance with the test procedures given in ANSI / TIA / EIA-603-C-2004 and the testing has shown the tested sample to be in compliance with the applicable technical standards.

The test results in this report apply exclusively to the tested model / sample. Without written approval of SPORTON INTERNATIONAL INC., the test report shall not be reproduced except in full.

Reviewed by: Joseph Lin / Supervisor

Approved by: Jones Tsai / Manager



Testing Laboratory  
1190

## SPORTON INTERNATIONAL INC.

No. 52, Hwa Ya 1<sup>st</sup> Rd., Hwa Ya Technology Park, Kwei-Shan District, Tao Yuan City, Taiwan, R.O.C.



TABLE OF CONTENTS

REVISION HISTORY..... 3
SUMMARY OF TEST RESULT ..... 4
1 GENERAL DESCRIPTION ..... 6
1.1 Applicant ..... 6
1.2 Manufacturer ..... 6
1.3 Product Feature of Equipment Under Test..... 6
1.4 Product Specification subjective to this standard ..... 7
1.5 Modification of EUT ..... 7
1.6 Emission Designator ..... 8
1.7 Testing Location ..... 10
1.8 Applicable Standards ..... 10
2 TEST CONFIGURATION OF EQUIPMENT UNDER TEST ..... 11
2.1 Test Mode ..... 11
2.2 Connection Diagram of Test System ..... 14
2.3 Support Unit used in test configuration and system ..... 15
2.4 Measurement Results Explanation Example ..... 15
3 CONDUCTED TEST ITEMS ..... 16
3.1 Measuring Instruments ..... 16
3.2 Test Setup ..... 16
3.3 Test Result of Conducted Test ..... 17
3.4 Conducted Output Power ..... 17
3.5 Peak-to-Average Ratio ..... 18
3.6 Occupied Bandwidth ..... 19
3.7 Conducted Band Edge ..... 20
3.8 Conducted Spurious Emission ..... 22
3.9 Frequency Stability ..... 23
4 RADIATED TEST ITEMS ..... 24
4.1 Measuring Instruments ..... 24
4.2 Test Setup ..... 24
4.3 Test Result of Radiated Test ..... 24
4.4 Effective Radiated Power and Effective Isotropic Radiated Power ..... 25
4.5 Radiated Spurious Emission ..... 27
5 LIST OF MEASURING EQUIPMENT ..... 28
6 UNCERTAINTY OF EVALUATION ..... 29
APPENDIX A. TEST RESULTS OF CONDUCTED TEST
APPENDIX B. TEST RESULTS OF RADIATED TEST



## REVISION HISTORY

REPORT NO.	VERSION	DESCRIPTION	ISSUED DATE
FG541573B	Rev. 01	Initial issue of report	Jun. 18, 2015
FG541573B	Rev. 02	Updating the Emission Designator in section 1.6.	Jul. 01, 2015



**SUMMARY OF TEST RESULT**

Report Section	FCC Rule	Description	Limit	Result	Remark
3.4	§2.1046	Conducted Output Power	Reporting Only	PASS	-
3.5	§24.232(d)	Peak-to-Average Ratio	<13 dB	PASS	-
3.6	§2.1049 §22.917(b) §24.238(b) §27.53(h)(3) §27.53(m)(6)	Occupied Bandwidth	Reporting Only	PASS	-
3.7	§2.1051 §22.917(a) §24.238(a) §27.53(g) §27.53(m)(4)	Conducted Band Edge Measurement (Band 2) (Band 4) (Band 5) (Band 12) (Band 17) (Band 25) (Band 7) (Band 41)	< 43+10log <sub>10</sub> (P[Watts])	PASS	-
3.8	§2.1051 §22.917(a) §24.238(a) §27.53(g)	Conducted Spurious Emission (Band 2) (Band 4) (Band 5) (Band 12) (Band 17) (Band 25)	< 43+10log <sub>10</sub> (P[Watts])	PASS	-
	§2.1051 §27.53(m)(4)	Conducted Spurious Emission (Band 7)(Band 41)	< 55+10log <sub>10</sub> (P[Watts])		
3.9	§2.1055 §22.355 §24.235 §27.54	Frequency Stability Temperature & Voltage	< 2.5 ppm for Part 22 Within Authorized Band	PASS	-



Report Section	FCC Rule	Description	Limit	Result	Remark
4.4	§22.913(a)(2)	Effective Radiated Power (Band 5)	ERP < 7 Watt	PASS	-
	§27.50(c)(10)	Effective Radiated Power (Band 12) (Band 17)	ERP < 3 Watt		
	§24.232(c) §27.50(h)(2)	Equivalent Isotropic Radiated Power (Band 2)(Band 25) (Band 7)(Band 41)	EIRP < 2Watt		
	§27.50(d)(4)	Equivalent Isotropic Radiated Power (Band 4)	EIRP < 1Watt		
4.5	§2.1053 §22.917(a) §24.238(a) §27.53(g) §27.53(h)	Radiated Spurious Emission (Band 2) (Band 4) (Band 5) (Band 12) (Band 17) (Band 25)	< 43+10log10(P[Watts])	PASS	Under limit 21.43 dB at 10686.000 MHz
	§2.1053 §27.53(m)(4)	Radiated Spurious Emission (Band 7) (Band 41)	< 55+10log10(P[Watts])		



# 1 General Description

## 1.1 Applicant

Motorola Mobility, LLC

222 W Merchandise Mart Plaza, Suite 1800, Chicago, IL 60654, United States

## 1.2 Manufacturer

Motorola Mobility, LLC

222 W Merchandise Mart Plaza, Suite 1800, Chicago, IL 60654, United States

## 1.3 Product Feature of Equipment Under Test

Product Feature	
Equipment	Mobile Cellular Phone
Brand Name	Motorola
Model Name	5137
FCC ID	IHDT56UC2
EUT supports Radios application	GSM/EGPRS/WCDMA/HSPA/LTE/NFC 2.4GHz WLAN 11b/g/n HT20 WLAN 11ac VHT20 5GHz WLAN 11a/n HT20/HT40 WLAN 11ac VHT20/VHT40/VHT80 Bluetooth v3.0 EDR Bluetooth v4.1 - LE
HW Version	P2
EUT Stage	Production Unit

Accessory List	
AC Adapter 1	Brand Name : Motorola
	Model Name : SPN5791A
AC Adapter 2	Brand Name : Motorola
	Model Name : SPN5864A
AC Adapter 3	Brand Name : Motorola
	Model Name : SPN5886A
USB Cable	Brand Name : Motorola
	Model Name : SKN6461A
Battery	Brand Name : Motorola
	Model Name : FX30
Earphone	Brand Name : Motorola
	Model Name : SJYN1305A



### 1.4 Product Specification subjective to this standard

Product Specification subjective to this standard	
<b>Tx Frequency</b>	LTE Band 2 : 1850.7 MHz ~ 1909.3 MHz LTE Band 4 : 1710.7 MHz ~ 1754.3 MHz LTE Band 5 : 824.7 MHz ~ 848.3 MHz LTE Band 7 : 2502.5 MHz ~ 2567.5 MHz LTE Band 12 : 699.7 MHz ~ 715.3 MHz LTE Band 17 : 706.5 MHz ~ 713.5 MHz LTE Band 25 : 1850.7MHz ~ 1914.3 MHz LTE Band 41 : 2503.5 MHz ~ 2682.5 MHz
<b>Rx Frequency</b>	LTE Band 2 : 1930.7 MHz ~ 1989.3 MHz LTE Band 4 : 2110.7 MHz ~ 2154.3 MHz LTE Band 5 : 869.7 MHz ~ 893.3 MHz LTE Band 7 : 2622.5MHz ~ 2687.5 MHz LTE Band 12 : 729.7 MHz ~ 745.3 MHz LTE Band 17 : 736.5 MHz ~ 743.5 MHz LTE Band 25 : 1930.7MHz ~ 1994.3 MHz LTE Band 41 : 2503.5 MHz ~ 2682.5 MHz
<b>Bandwidth</b>	LTE Band 2 : 1.4MHz / 3MHz / 5MHz / 10MHz / 15MHz / 20MHz LTE Band 4 : 1.4MHz / 3MHz / 5MHz / 10MHz / 15MHz / 20MHz LTE Band 5 : 1.4MHz / 3MHz / 5MHz / 10MHz LTE Band 7 : 5MHz / 10MHz / 15MHz / 20MHz LTE Band 12 : 1.4MHz / 3MHz / 5MHz / 10MHz LTE Band 17 : 5MHz / 10MHz LTE Band 25 : 1.4MHz / 3MHz / 5MHz / 10MHz / 15MHz / 20MHz LTE Band 41 : 5MHz / 10MHz / 15MHz / 20MHz
<b>Maximum Output Power to Antenna</b>	LTE Band 2 : 23.36 dBm LTE Band 4 : 23.10 dBm LTE Band 5 : 22.65 dBm LTE Band 7 : 22.41 dBm LTE Band 12 : 22.72 dBm LTE Band 17 : 22.72 dBm LTE Band 25 : 23.56 dBm LTE Band 41 : 21.70 dBm
<b>Type of Modulation</b>	LTE: QPSK / 16QAM / 64QAM (Downlink only)

### 1.5 Modification of EUT

No modifications are made to the EUT during all test items.



### 1.6 Emission Designator

LTE Band 2		QPSK			16QAM		
BW(MHz)	Emission Designator (99%OBW)	Frequency Tolerance (ppm)	Maximum EIRP(W)	Emission Designator (99%OBW)	Frequency Tolerance (ppm)	Maximum EIRP(W)	
1.4	1M09G7D	-	0.2188	1M09W7D	-	0.1538	
3	2M73G7D	-	0.2208	2M73W7D	-	0.1535	
5	4M49G7D	-	0.2270	4M49W7D	-	0.1603	
10	9M09G7D	0.0013	0.2438	9M03W7D	-	0.1679	
15	13M5G7D	-	0.2594	13M5W7D	-	0.1803	
20	18M5G7D	-	0.2667	18M5W7D	-	0.1986	
LTE Band 25		QPSK			16QAM		
BW(MHz)	Emission Designator (99%OBW)	Frequency Tolerance (ppm)	Maximum EIRP(W)	Emission Designator (99%OBW)	Frequency Tolerance (ppm)	Maximum EIRP(W)	
1.4	1M09G7D	-	0.1888	1M09W7D	-	0.1563	
3	2M73G7D	-	0.1879	2M73W7D	-	0.1570	
5	4M49G7D	-	0.1879	4M49W7D	-	0.1578	
10	9M09G7D	0.0013	0.1945	9M01W7D	-	0.1702	
15	13M5G7D	-	0.2046	13M5W7D	-	0.1714	
20	18M3G7D	-	0.2203	18M5W7D	-	0.1816	
LTE Band 4		QPSK			16QAM		
BW(MHz)	Emission Designator (99%OBW)	Frequency Tolerance (ppm)	Maximum EIRP(W)	Emission Designator (99%OBW)	Frequency Tolerance (ppm)	Maximum EIRP(W)	
1.4	1M09G7D	-	0.1746	1M09W7D	-	0.1076	
3	2M73G7D	-	0.1758	2M73W7D	-	0.1059	
5	4M50G7D	-	0.1811	4M50W7D	-	0.1169	
10	9M11G7D	0.0074	0.1782	9M03W7D	-	0.1146	
15	13M5G7D	-	0.2113	13M5W7D	-	0.1343	
20	18M4G7D	-	0.1758	18M5W7D	-	0.1178	
LTE Band 5		QPSK			16QAM		
BW(MHz)	Emission Designator (99%OBW)	Frequency Tolerance (ppm)	Maximum ERP(W)	Emission Designator (99%OBW)	Frequency Tolerance (ppm)	Maximum ERP(W)	
1.4	1M09G7D	-	0.1030	1M09W7D	-	0.0802	
3	2M72G7D	-	0.1052	2M73W7D	-	0.0748	
5	4M50G7D	-	0.1000	4M50W7D	-	0.0703	
10	9M07G7D	0.0158	0.0993	9M03W7D	-	0.0719	



LTE Band 7		QPSK			16QAM		
BW(MHz)	Emission Designator (99%OBW)	Frequency Tolerance (ppm)	Maximum EIRP(W)	Emission Designator (99%OBW)	Frequency Tolerance (ppm)	Maximum EIRP(W)	
5	4M49G7D	-	0.1799	4M49W7D	-	0.1205	
10	9M07G7D	-	0.2099	9M03W7D	-	0.1161	
15	13M5G7D	-	0.1936	13M5W7D	-	0.1242	
20	18M5G7D	0.0014	0.1854	18M6W7D	-	0.1230	
LTE Band 12		QPSK			16QAM		
BW(MHz)	Emission Designator (99%OBW)	Frequency Tolerance (ppm)	Maximum ERP(W)	Emission Designator (99%OBW)	Frequency Tolerance (ppm)	Maximum ERP(W)	
1.4	1M09G7D	-	0.0465	1M09W7D	-	0.0776	
3	2M73G7D	-	0.0476	2M73W7D	-	0.0705	
5	4M50G7D	-	0.0760	4M49W7D	-	0.0434	
10	9M05G7D	0.0107	0.0557	9M03W7D	-	0.0478	
LTE Band 17		QPSK			16QAM		
BW(MHz)	Emission Designator (99%OBW)	Frequency Tolerance (ppm)	Maximum ERP(W)	Emission Designator (99%OBW)	Frequency Tolerance (ppm)	Maximum ERP(W)	
5	4M50G7D	-	0.0796	4M50W7D	-	0.0444	
10	9M09G7D	0.0107	0.0667	9M05W7D	-	0.0533	
LTE Band 41		QPSK			16QAM		
BW(MHz)	Emission Designator (99%OBW)	Frequency Tolerance (ppm)	Maximum EIRP(W)	Emission Designator (99%OBW)	Frequency Tolerance (ppm)	Maximum EIRP(W)	
5	4M52G7D	-	0.2377	4M50W7D	-	0.1629	
10	9M03G7D	-	0.2399	9M05W7D	-	0.1618	
15	13M5G7D	-	0.2443	13M5W7D	-	0.1493	
20	18M5G7D	0.0013	0.2344	18M4W7D	-	0.1469	



### 1.7 Testing Location

Sporton Lab is accredited to ISO 17025 by Taiwan Accreditation Foundation (TAF code : 1190) and the FCC designation No. TW1022 under the FCC 2.948(e) by Mutual Recognition Agreement (MRA) in FCC Test.

<b>Test Site</b>	SPORTON INTERNATIONAL INC.	
<b>Test Site Location</b>	No. 52, Hwa Ya 1 <sup>st</sup> Rd., Hwa Ya Technology Park, Kwei-Shan District, Tao Yuan City, Taiwan, R.O.C. TEL: +886-3-327-3456 FAX: +886-3-328-4978	
<b>Test Site No.</b>	<b>Sporton Site No.</b>	
	TH02-HY	03CH07-HY

### 1.8 Applicable Standards

According to the specifications of the manufacturer, the EUT must comply with the requirements of the following standards:

- 47 CFR Part 2, 22(H), 24(E), 27
- ANSI / TIA / EIA-603-C-2004
- FCC KDB 971168 D01 Power Meas. License Digital Systems v02r02

**Remark:**

1. All test items were verified and recorded according to the standards and without any deviation during the test.
2. This EUT has also been tested and complied with the requirements of FCC Part 15, Subpart B, recorded in a separate test report.



## 2 Test Configuration of Equipment Under Test

### 2.1 Test Mode

Antenna port conducted and radiated test items listed below are performed according to KDB 971168 D01 Power Meas. License Digital Systems v02r02 with maximum output power.

Radiated measurements are performed by rotating the EUT in three different orthogonal test planes to find the maximum emission.

Test Items	Band	Bandwidth (MHz)						Modulation		RB #			Test Channel		
		1.4	3	5	10	15	20	QPSK	16QAM	1	Half	Full	L	M	H
Max. Output Power	2	✓	✓	✓	✓	✓	✓	✓	✓	✓	✓	✓	✓	✓	✓
	4	✓	✓	✓	✓	✓	✓	✓	✓	✓	✓	✓	✓	✓	✓
	5	✓	✓	✓	✓	-	-	✓	✓	✓	✓	✓	✓	✓	✓
	7	-	-	✓	✓	✓	✓	✓	✓	✓	✓	✓	✓	✓	✓
	12	✓	✓	✓	✓	-	-	✓	✓	✓	✓	✓	✓	✓	✓
	17	-	-	✓	✓	-	-	✓	✓	✓	✓	✓	✓	✓	✓
	25	✓	✓	✓	✓	✓	✓	✓	✓	✓	✓	✓	✓	✓	✓
	41	-	-	✓	✓	✓	✓	✓	✓	✓	✓	✓	✓	✓	✓
Peak-to-Average Ratio	2						✓	✓	✓	✓		✓	✓	✓	✓
	4						✓	✓	✓	✓		✓	✓	✓	✓
	5				✓	-	-	✓	✓	✓		✓	✓	✓	✓
	7	-	-				✓	✓	✓	✓		✓	✓	✓	✓
	12				✓	-	-	✓	✓	✓		✓	✓	✓	✓
	17	-	-		✓	-	-	✓	✓	✓		✓	✓	✓	✓
	25						✓	✓	✓	✓		✓	✓	✓	✓
	41	-	-				✓	✓	✓	✓		✓	✓	✓	✓
26dB and 99% Bandwidth	2	✓	✓	✓	✓	✓	✓	✓	✓			✓	✓	✓	✓
	4	✓	✓	✓	✓	✓	✓	✓	✓			✓	✓	✓	✓
	5	✓	✓	✓	✓	-	-	✓	✓			✓	✓	✓	✓
	7	-	-	✓	✓	✓	✓	✓	✓			✓	✓	✓	✓
	12	✓	✓	✓	✓	-	-	✓	✓			✓	✓	✓	✓
	17	-	-	✓	✓	-	-	✓	✓			✓	✓	✓	✓
	25	✓	✓	✓	✓	✓	✓	✓	✓			✓	✓	✓	✓
	41	-	-	✓	✓	✓	✓	✓	✓			✓	✓	✓	✓



Test Items	Band	Bandwidth (MHz)						Modulation		RB #			Test Channel		
		1.4	3	5	10	15	20	QPSK	16QAM	1	Half	Full	L	M	H
Conducted Band Edge	2	✓	✓	✓	✓	✓	✓	✓	✓	✓		✓	✓		✓
	4	✓	✓	✓	✓	✓	✓	✓	✓	✓		✓	✓		✓
	5	✓	✓	✓	✓	-	-	✓	✓	✓		✓	✓		✓
	7	-	-	✓	✓	✓	✓	✓	✓	✓		✓	✓		✓
	12	✓	✓	✓	✓	-	-	✓	✓	✓		✓	✓		✓
	17	-	-	✓	✓	-	-	✓	✓	✓		✓	✓		✓
	25	✓	✓	✓	✓	✓	✓	✓	✓	✓		✓	✓		✓
	41	-	-	✓	✓	✓	✓	✓	✓	✓		✓	✓		✓
Conducted Spurious Emission	2	✓	✓	✓	✓	✓	✓	✓	✓	✓			✓	✓	✓
	4	✓	✓	✓	✓	✓	✓	✓	✓	✓			✓	✓	✓
	5	✓	✓	✓	✓	-	-	✓	✓	✓			✓	✓	✓
	7	-	-	✓	✓	✓	✓	✓	✓	✓			✓	✓	✓
	12	✓	✓	✓	✓	-	-	✓	✓	✓			✓	✓	✓
	17	-	-	✓	✓	-	-	✓	✓	✓			✓	✓	✓
	25	✓	✓	✓	✓	✓	✓	✓	✓	✓			✓	✓	✓
	41	-	-	✓	✓	✓	✓	✓	✓	✓			✓	✓	✓
Frequency Stability	2				✓			✓				✓		✓	
	4				✓			✓				✓		✓	
	5				✓	-	-	✓				✓		✓	
	7	-	-		✓			✓				✓		✓	
	12				✓	-	-	✓				✓		✓	
	17	-	-		✓	-	-	✓				✓		✓	
	25				✓			✓				✓		✓	
	41	-	-		✓			✓				✓		✓	



Test Items	Band	Bandwidth (MHz)						Modulation		RB #			Test Channel		
		1.4	3	5	10	15	20	QPSK	16QAM	1	Half	Full	L	M	H
E.R.P./E.I.R.P.	2	v	v	v	v	v	v	v	v	v			v	v	v
	4	v	v	v	v	v	v	v	v	v			v	v	v
	5	v	v	v	v	-	-	v	v	v			v	v	v
	7	-	-	v	v	v	v	v	v	v			v	v	v
	12	v	v	v	v	v	v	v	v	v			v	v	v
	17	-	-	v	v	-	-	v	v	v			v	v	v
	25	v	v	v	v	v	v	v	v	v			v	v	v
	41	-	-	v	v	v	v	v	v	v			v	v	v
Radiated Spurious Emission	2	v	v	v	v	v	v	v		v			v	v	v
	4	v	v	v	v	v	v	v		v			v	v	v
	5	v	v	v	v	-	-	v		v			v	v	v
	7	-	-	v	v	v	v	v		v			v	v	v
	12	v	v	v	v	-	-	v		v			v	v	v
	13	-	-	v	v	-	-	v		v			v	v	v
	17	-	-	v	v	-	-	v		v			v	v	v
	25	v	v	v	v	v	v	v		v			v	v	v
41	-	-	v	v	v	v	v		v			v	v	v	
Note	<p>1. The mark "v" means that this configuration is chosen for testing</p> <p>2. The mark "-" means that this bandwidth is not supported.</p> <p>3. The device is investigated from 30MHz to 10 times of fundamental signal for radiated spurious emission test under different RB size/offset and modulations in exploratory test. Subsequently, only the worst case emissions are reported.</p>														

## 2.2 Connection Diagram of Test System

<For AC Adapter 1>

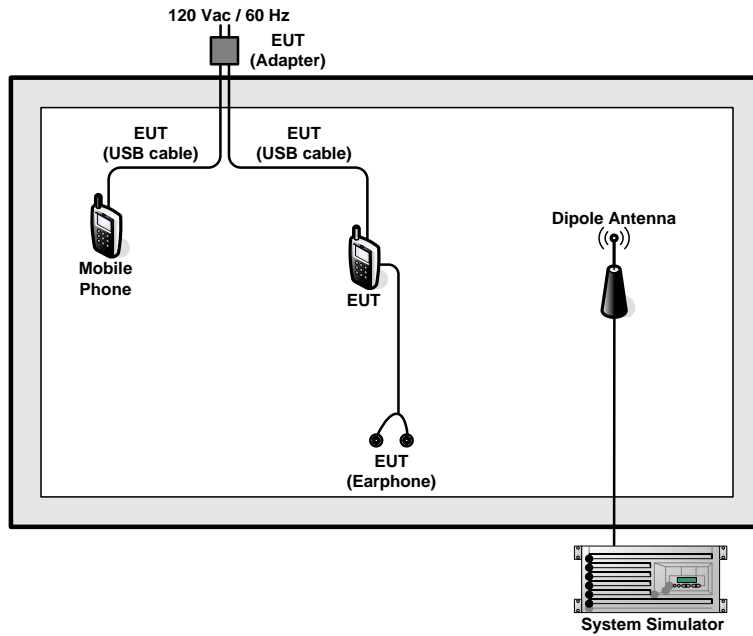

<For AC Adapter 2>

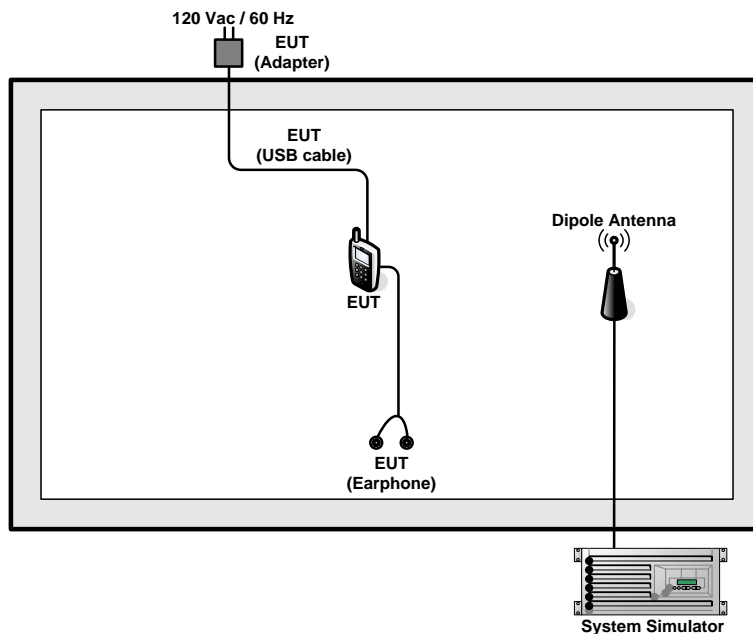

<For AC Adapter 3>

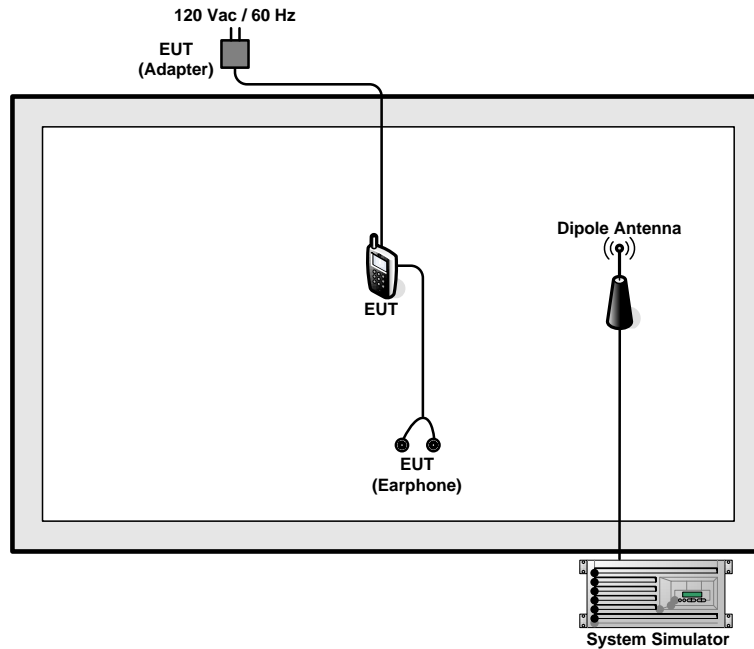

### 2.3 Support Unit used in test configuration and system

Item	Equipment	Trade Name	Model No.	FCC ID	Data Cable	Power Cord
1.	LTE Base Station	Anritsu	MT8820C	N/A	N/A	Unshielded, 1.8 m

### 2.4 Measurement Results Explanation Example

**For all conducted test items:**

The offset level is set in the spectrum analyzer to compensate the RF cable loss and attenuator factor between EUT conducted output port and spectrum analyzer. With the offset compensation, the spectrum analyzer reading level is exactly the EUT RF output level.

The spectrum analyzer offset is derived from RF cable loss and attenuator factor.

*Offset = RF cable loss + attenuator factor.*

Following shows an offset computation example with cable loss 4.2 dB and 10dB attenuator.

Example :

$$\begin{aligned}
 \text{Offset(dB)} &= \text{RF cable loss(dB)} + \text{attenuator factor(dB)}. \\
 &= 4.2 + 10 = 14.2 \text{ (dB)}
 \end{aligned}$$

### 3 Conducted Test Items

#### 3.1 Measuring Instruments

See list of measuring instruments of this test report.

#### 3.2 Test Setup

##### 3.2.1 Conducted Output Power

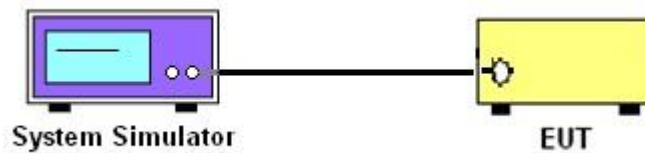

##### 3.2.2 Peak-to-Average Ratio, Occupied Bandwidth ,Conducted Band-Edge and Conducted Spurious Emission

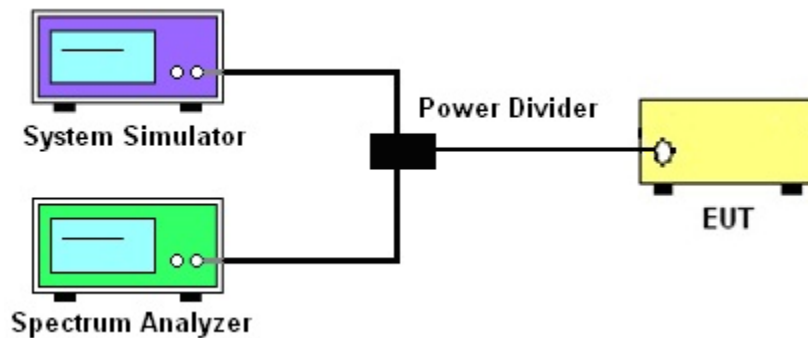

##### 3.2.3 Frequency Stability

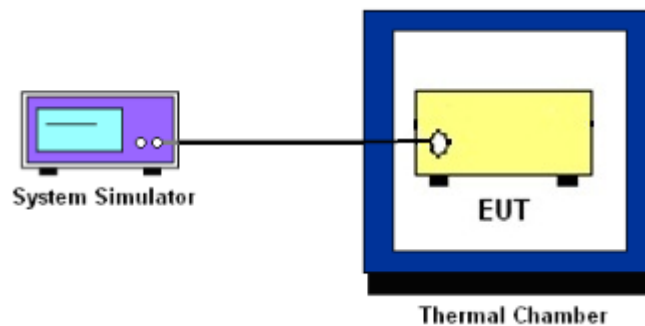



### **3.3 Test Result of Conducted Test**

Please refer to Appendix A.

### **3.4 Conducted Output Power**

#### **3.4.1 Description of the Conducted Output Power Measurement**

A system simulator was used to establish communication with the EUT. Its parameters were set to force the EUT transmitting at maximum output power. The measured power in the radio frequency on the transmitter output terminals shall be reported.

#### **3.4.2 Test Procedures**

1. The transmitter output port was connected to the system simulator.
2. Set EUT at maximum power through the system simulator.
3. Select lowest, middle, and highest channels for each band and different modulation.
4. Measure and record the power level from the system simulator.



## **3.5 Peak-to-Average Ratio**

### **3.5.1 Description of the PAR Measurement**

Power Complementary Cumulative Distribution Function (CCDF) curves provide a means for characterizing the power peaks of a digitally modulated signal on a statistical basis. A CCDF curve depicts the probability of the peak signal amplitude exceeding the average power level. Most contemporary measurement instrumentation include the capability to produce CCDF curves for an input signal provided that the instrument's resolution bandwidth can be set wide enough to accommodate the entire input signal bandwidth. In measuring transmissions in this band using an average power technique, the peak-to-average ratio (PAR) of the transmission may not exceed 13 dB.

### **3.5.2 Test Procedures**

1. The testing follows FCC KDB 971168 v02r02 Section 5.7.1.
2. The EUT was connected to spectrum and system simulator via a power divider.
3. Set the CCDF (Complementary Cumulative Distribution Function) option in spectrum analyzer.
4. The highest RF powers were measured and recorded the maximum PAPR level associated with a probability of 0.1 %.
5. Record the deviation as Peak to Average Ratio.



## **3.6 Occupied Bandwidth**

### **3.6.1 Description of Occupied Bandwidth Measurement**

The occupied bandwidth is the width of a frequency band such that, below the lower and above the upper frequency limits, the mean powers emitted are each equal to a specified percentage 0.5% of the total mean transmitted power.

The 26 dB emission bandwidth is defined as the frequency range between two points, one above and one below the carrier frequency, at which the spectral density of the emission is attenuated 26 dB below the maximum in-band spectral density of the modulated signal. Spectral density (power per unit bandwidth) is to be measured with a detector of resolution bandwidth equal to approximately 1.0% of the emission bandwidth.

### **3.6.2 Test Procedures**

1. The testing follows FCC KDB 971168 v02r02 Section 4.2.
2. The EUT was connected to spectrum analyzer and system simulator via a power divider.



### **3.7 Conducted Band Edge**

#### **3.7.1 Description of Conducted Band Edge Measurement**

22.917(a) for Band 5

For operations in the 824 – 849 MHz band, the FCC limit is  $43 + 10\log_{10}(P[\text{Watts}])$  dB below the transmitter power  $P(\text{Watts})$  in a 100kHz bandwidth. However, in the 1MHz bands immediately outside and adjacent to the licensee's frequency block, a resolution bandwidth of at least one percent of the emission bandwidth of the fundamental emission of the transmitter may be employed.

24.238 (a) for Band 2, 25

For operations in the 1850-1910 and 1930-1990 MHz band, the FCC limit is  $43 + 10\log_{10}(P[\text{Watts}])$  dB below the transmitter power  $P(\text{Watts})$  in a 1MHz bandwidth. However, in the 1 MHz bands immediately outside and adjacent to the frequency block a resolution bandwidth of at least one percent of the emission bandwidth of the fundamental emission of the transmitter may be employed.

27.53 (g) for Band 12,17

For operations in the 698 -746 MHz band, the FCC limit is  $43 + 10\log_{10}(P[\text{Watts}])$  dB below the transmitter power  $P(\text{Watts})$  in a 100 kHz bandwidth. However, in the 100 kilohertz bands immediately outside and adjacent to a licensee's frequency block, a resolution bandwidth of at least 30 kHz may be employed.

27.53 (h) for Band 4

For operations in the 1710 – 1755 MHz band, the FCC limit is  $43 + 10\log_{10}(P[\text{Watts}])$  dB below the transmitter power  $P(\text{Watts})$  in a 1 MHz bandwidth. However, in the 1MHz bands immediately outside and adjacent to the licensee's frequency block, a resolution bandwidth of at least one percent of the emission bandwidth of the fundamental emission of the transmitter may be employed.



27.53(m)(4) for Band 7,41:

For mobile digital stations, the attenuation factor shall be not less than  $40 + 10 \log (P)$  dB on all frequencies between the channel edge and 5 megahertz from the channel edge,  $43 + 10 \log (P)$  dB on all frequencies between 5 megahertz and X megahertz from the channel edge, and  $55 + 10 \log (P)$  dB on all frequencies more than X megahertz from the channel edge, where X is the greater of 6 megahertz or the actual emission bandwidth as defined in paragraph (m)(6) of this section. In addition, the attenuation factor shall not be less that  $43 + 10 \log (P)$  dB on all frequencies between 2490.5 MHz and 2496 MHz and  $55 + 10 \log (P)$  dB at or below 2490.5 MHz. Mobile Satellite Service licensees operating on frequencies below 2495 MHz may also submit a documented interference complaint against BRS licensees operating on channel BRS Channel 1 on the same terms and conditions as adjacent channel BRS or EBS licensees.

### **3.7.2 Test Procedures**

1. The testing follows FCC KDB 971168 v02r02 Section 6.0.
2. The EUT was connected to spectrum analyzer and system simulator via a power divider.
3. The band edges of low and high channels for the highest RF powers were measured. Set RBW  $\geq 1\%$  EBW in the 1MHz band immediately outside and adjacent to the band edge.
4. Set spectrum analyzer with RMS detector.
5. The RF fundamental frequency should be excluded against the limit line in the operating frequency band.
6. The limit line is derived from  $43 + 10\log(P)$ dB below the transmitter power P(Watts)  
=  $P(W) - [43 + 10\log(P)]$  (dB)  
=  $[30 + 10\log(P)]$  (dBm) -  $[43 + 10\log(P)]$  (dB)  
= -13dBm.



### 3.8 Conducted Spurious Emission

#### 3.8.1 Description of Conducted Spurious Emission Measurement

The power of any emission outside of the authorized operating frequency ranges must be lower than the transmitter power (P) by a factor of at least  $43 + 10 \log (P)$  dB.

For Band 7,41:

The power of any emission outside of the authorized operating frequency ranges must be lower than the transmitter power (P) by a factor of at least  $55 + 10 \log (P)$  dB.

It is measured by means of a calibrated spectrum analyzer and scanned from 30 MHz up to a frequency including its 10<sup>th</sup> harmonic.

#### 3.8.2 Test Procedures

1. The testing follows FCC KDB 971168 v02r02 Section 6.0.
2. The EUT was connected to spectrum analyzer and system simulator via a power divider.
3. The RF output of EUT was connected to the spectrum analyzer by RF cable and attenuator. The path loss was compensated to the results for each measurement.
4. The middle channel for the highest RF power within the transmitting frequency was measured.
5. The conducted spurious emission for the whole frequency range was taken.
6. Make the measurement with the spectrum analyzer's RBW = 1MHz, VBW = 3MHz, taking the record of maximum spurious emission.
7. The RF fundamental frequency should be excluded against the limit line in the operating frequency band.
8. The limit line is derived from  $43 + 10\log(P)$ dB below the transmitter power P(Watts)  
= P(W)- [43 + 10log(P)] (dB)  
= [30 + 10log(P)] (dBm) - [43 + 10log(P)] (dB)  
= -13dBm.
9. For Band 7, 41  
The limit line is derived from  $55 + 10\log(P)$ dB below the transmitter power P(Watts)



## 3.9 Frequency Stability

### 3.9.1 Description of Frequency Stability Measurement

The frequency stability shall be measured by variation of ambient temperature and variation of primary supply voltage to ensure that the fundamental emission stays within the authorized frequency block. The frequency stability of the transmitter shall be maintained within  $\pm 0.00025\%$  ( $\pm 2.5\text{ppm}$ ) of the center frequency.

### 3.9.2 Test Procedures for Temperature Variation

1. The EUT was set up in the thermal chamber and connected with the system simulator.
2. With power OFF, the temperature was decreased to  $-30^{\circ}\text{C}$  and the EUT was stabilized before testing. Power was applied and the maximum change in frequency was recorded within one minute.
3. With power OFF, the temperature was raised in  $10^{\circ}\text{C}$  step up to  $50^{\circ}\text{C}$ . The EUT was stabilized at each step for at least half an hour. Power was applied and the maximum frequency change was recorded within one minute.
- 4.

### 3.9.3 Test Procedures for Voltage Variation

1. The testing follows FCC KDB 971168 v02r02 Section 9.0.
2. The EUT was placed in a temperature chamber at  $25\pm 5^{\circ}\text{C}$  and connected with the system simulator.
3. The power supply voltage to the EUT was varied from 85% to 115% of the nominal value measured at the input to the EUT.
4. The variation in frequency was measured for the worst case.

## 4 Radiated Test Items

### 4.1 Measuring Instruments

See list of measuring instruments of this test report.

### 4.2 Test Setup

#### 4.2.1 For radiated test from 30MHz to 1GHz

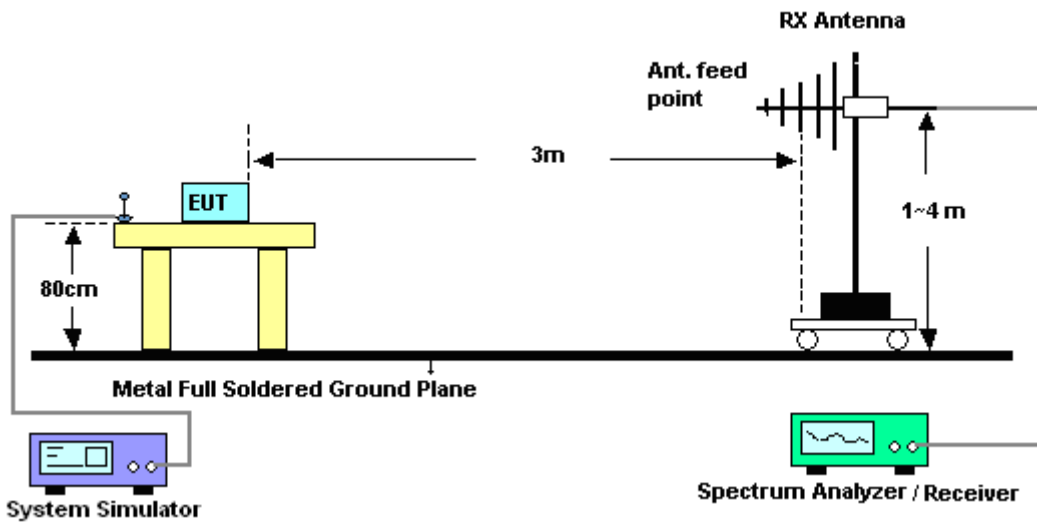

#### 4.2.2 For radiated test above 1GHz

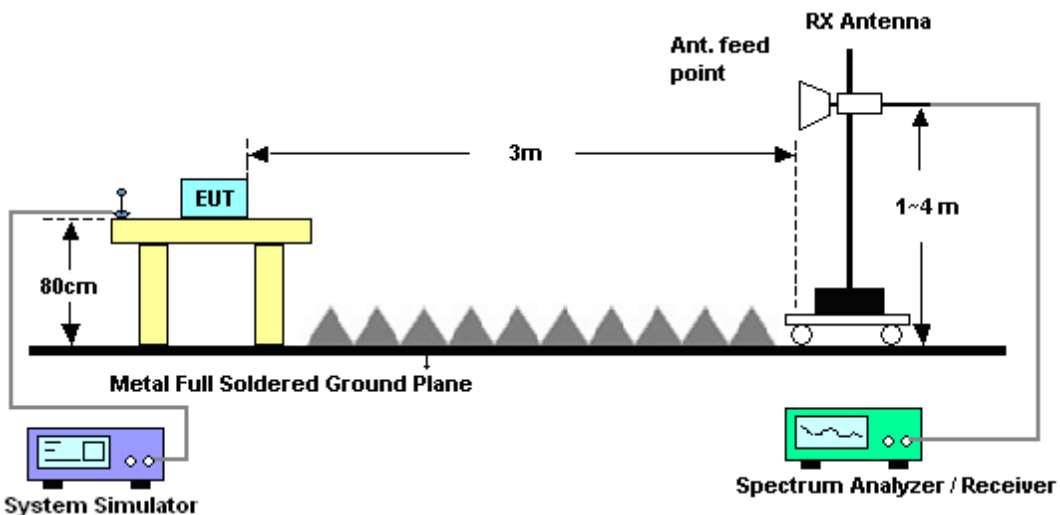

### 4.3 Test Result of Radiated Test

Please refer to Appendix B.



## 4.4 Effective Radiated Power and Effective Isotropic Radiated Power

### 4.4.1 Description of the ERP/EIRP Measurement

Effective radiated power output measurements by substitution method according to ANSI / TIA / EIA-603-C-2004, and the spectrum analyzer configuration follows KDB 971168 D01 Power Meas. License Digital Systems v02r02. Mobile and portable (hand-held) stations operating are limited to average ERP of 7 watts with LTE band 5 and 3 watts with LTE band 12 / 17.

Equivalent isotropic radiated power output measurements by substitution method according to ANSI / TIA / EIA-603-C-2004, and the spectrum analyzer configuration follows KDB 971168 D01 Power Meas. License Digital Systems v02r02. Mobile and portable (hand-held) stations operating are limited to average EIRP of 2 watts with LTE band 2 / 25 / 7 / 41 and 1 watt with LTE band 4.

### 4.4.2 Test Procedures

1. The EUT was placed on a non-conductive rotating platform 0.8 meters high in a semi-anechoic chamber. The radiated emission at the fundamental frequency was measured at 3 m with a test antenna and a spectrum analyzer with RMS detector per section 5. of KDB 971168 D01.
2. During the measurement, the system simulator parameters were set to force the EUT transmitting at maximum output power. The maximum emission was recorded from analyzer power level (LVL) from the 360 degrees rotation of the turntable and the test antenna raised and lowered over a range from 1 to 4 meters in both horizontally and vertically polarized orientations.
1. Effective Isotropic Radiated Power (EIRP) was measured by substitution method according to TIA/EIA-603-C. The EUT was replaced by the substitution antenna at same location, and then a known power from S.G. was applied into the dipole antenna through a Tx cable, and then recorded the maximum Analyzer reading through raised and lowered the test antenna. The correction factor (in dB) = S.G. - Tx Cable loss + Substitution antenna gain - Analyzer reading. Then the EUT's EIRP was calculated with the correction factor,  $EIRP = LVL + \text{Correction factor}$  and  $ERP = EIRP - 2.15$ . Take the record of the output power at substitution antenna.



	LTE					
LTE BW	1.4M	3M	5M	10M	15M	20M
Span	3MHz	6MHz	10MHz	20MHz	30MHz	40MHz
RBW	30kHz	100kHz	100kHz	300kHz	300kHz	300kHz
VBW	100kHz	300kHz	300kHz	1MHz	1MHz	1MHz
Detector	RMS	RMS	RMS	RMS	RMS	RMS
Trace	Average	Average	Average	Average	Average	Average
Average Type	Power	Power	Power	Power	Power	Power
Sweep Count	100	100	100	100	100	100



## 4.5 Radiated Spurious Emission

### 4.5.1 Description of Radiated Spurious Emission

The radiated spurious emission was measured by substitution method according to ANSI / TIA / EIA-603-C-2004. The power of any emission outside of the authorized operating frequency ranges must be attenuated below the transmitter power (P) by a factor of at least  $43 + 10 \log (P)$  dB.

For Band 7, 41

The power of any emission outside of the authorized operating frequency ranges must be attenuated below the transmitter power (P) by a factor of at least  $55 + 10 \log (P)$  dB.

For LTE Band 12, 17

For operations in the 746-758 MHz, 775-788 MHz, and 805-806 MHz bands, emissions in the band 1559-1610 MHz shall be limited to  $-70$  dBW/MHz equivalent isotropically radiated power (EIRP) for wideband signals, and  $-80$  dBW EIRP for discrete emissions of less than 700 Hz bandwidth.

The spectrum is scanned from 30 MHz up to a frequency including its 10th harmonic.

### 4.5.2 Test Procedures

1. The testing follows FCC KDB 971168 v02r02 Section 5.8 and ANSI / TIA-603-C-2004 Section 2.2.12.
2. The EUT was placed on a rotatable wooden table with 0.8 meter above ground.
3. The EUT was set 3 meters from the receiving antenna, which was mounted on the antenna tower.
4. The table was rotated 360 degrees to determine the position of the highest spurious emission.
5. The height of the receiving antenna is varied between one meter and four meters to search the maximum spurious emission for both horizontal and vertical polarizations.
6. Make the measurement with the spectrum analyzer's RBW = 1MHz, VBW = 3MHz, taking the record of maximum spurious emission.
7. A horn antenna was substituted in place of the EUT and was driven by a signal generator.
8. Tune the output power of signal generator to the same emission level with EUT maximum spurious emission.
9. Taking the record of output power at antenna port.
10. Repeat step 7 to step 8 for another polarization.
11. The RF fundamental frequency should be excluded against the limit line in the operating frequency band.

The limit line is derived from  $43 + 10\log(P)$ dB below the transmitter power P(Watts)

$$= P(W) - [43 + 10\log(P)] \text{ (dB)}$$

$$= [30 + 10\log(P)] \text{ (dBm)} - [43 + 10\log(P)] \text{ (dB)}$$

$$= -13\text{dBm.}$$

For Band 7,41:

The limit line is derived from  $55 + 10\log(P)$ dB below the transmitter power P(Watts)

$$12. \text{ EIRP (dBm)} = \text{S.G. Power} - \text{Tx Cable Loss} + \text{Tx Antenna Gain}$$

$$13. \text{ ERP (dBm)} = \text{EIRP} - 2.15$$



## 5 List of Measuring Equipment

Instrument	Manufacturer	Model No.	Serial No.	Characteristics	Calibration Date	Test Date	Due Date	Remark
LTE Base Station	Anritsu	MT8820C	6201432821	GSM/GPRS /WCDMA/LTE	Oct. 27, 2014	Apr. 21, 2015 ~ May 02, 2015	Oct. 26, 2015	Conducted (TH05-HY)
Spectrum Analyzer	Rohde & Schwarz	FSV40	101397	10Hz~40GHz	Sep. 17, 2014	Apr. 21, 2015 ~ May 02, 2015	Sep. 16 2015	Conducted (TH05-HY)
Temperature Chamber	ESPEC	SH-641	92013720	N/A	Dec. 04, 2014	Apr. 21, 2015 ~ May 02, 2015	Dec. 03, 2015	Conducted (TH05-HY)
Bilog Antenna	Schaffner	CBL6111C	2726	30MHz ~ 1GHz	Sep. 27, 2014	Apr. 21, 2015 ~ May 20, 2015	Sep. 26, 2015	Radiation (03CH07-HY)
Double Ridge Horn Antenna	ESCO	3117	00075962	1GHz ~ 18GHz	Aug. 19, 2014	Apr. 21, 2015 ~ May 20, 2015	Aug. 18, 2015	Radiation (03CH07-HY)
EMI Test Receiver	Rohde & Schwarz	ESCI 7	100724	9kHz~7GHz	Aug. 30, 2014	Apr. 21, 2015 ~ May 20, 2015	Aug. 29, 2015	Radiation (03CH07-HY)
Horn Antenna	SCHWARZBECK	BBHA 9120D	9120D-1328	1GHz ~ 18GHz	Nov. 05, 2014	Apr. 21, 2015 ~ May 20, 2015	Nov. 04, 2015	Radiation (03CH07-HY)
Horn Antenna	SCHWARZBECK	BBHA 9170	BBHA9170584	18GHz- 40GHz	Nov. 03, 2014	Apr. 21, 2015 ~ May 20, 2015	Nov. 02, 2015	Radiation (03CH07-HY)
Preamplifier	COM-POWER	PA-103A	161241	10MHz-1000MHz	Mar. 12, 2015	Apr. 21, 2015 ~ May 20, 2015	Mar. 11, 2016	Radiation (03CH07-HY)
Preamplifier	Agilent	8449B	3008A02362	1GHz~ 26.5GHz	Oct. 21, 2014	Apr. 21, 2015 ~ May 20, 2015	Oct. 20, 2015	Radiation (03CH07-HY)
Signal Analyzer	Rohde & Schwarz	FSV 30	101749	10Hz~30GHz	Mar. 10, 2015	Apr. 21, 2015 ~ May 20, 2015	Mar. 09, 2016	Radiation (03CH07-HY)
Antenna Mast	Max-Full	MFA520BS	N/A	1m~4m	N/A	Apr. 21, 2015 ~ May 20, 2015	N/A	Radiation (03CH07-HY)
Turn Table	ChainTek	Chaintek 3000	N/A	0~360 degree	N/A	Apr. 21, 2015 ~ May 20, 2015	N/A	Radiation (03CH07-HY)
Signal Generator	Rohde & Schwarz	SMF100A	101107	100kHz~40GHz	May 23, 2014	Apr. 21, 2015 ~ May 20, 2015	May 22, 2015	Radiation (03CH07-HY)



## 6 Uncertainty of Evaluation

### Uncertainty of Radiated Emission Measurement (30 MHz ~ 1000 MHz)

Measuring Uncertainty for a Level of Confidence of 95% ( $U = 2Uc(y)$ )	4.50
---	------



## Appendix A. Test Results of Conducted Test

### Conducted Output Power(Average power)

LTE Band 2 Maximum Average Power [dBm]						
BW [MHz]	RB Size	RB Offset	Mod	Lowest	Middle	Highest
1.4	1	0	QPSK	22.75	22.91	23.03
1.4	1	2		22.28	22.24	22.36
1.4	1	5		22.11	22.40	22.57
1.4	3	0		22.09	22.36	22.37
1.4	3	1		22.07	22.34	22.35
1.4	3	2		22.06	22.31	22.36
1.4	6	0		21.26	21.35	21.53
1.4	1	0	16-QAM	21.94	22.02	22.18
1.4	1	2		21.45	21.64	21.79
1.4	1	5		21.36	21.75	21.79
1.4	3	0		21.21	21.25	21.61
1.4	3	1		21.19	21.24	21.57
1.4	3	2		21.12	21.21	21.53
1.4	6	0		20.28	20.55	20.57
3	1	0	QPSK	22.96	23.16	23.19
3	1	7		22.27	22.51	22.53
3	1	14		22.35	22.54	22.54
3	8	0		21.55	21.64	21.74
3	8	4		21.48	21.51	21.88
3	8	7		21.43	21.49	21.61
3	15	0		21.44	21.47	21.77
3	1	0	16-QAM	22.17	22.23	22.35
3	1	7		21.46	21.63	21.60
3	1	14		21.49	21.90	21.90
3	8	0		20.51	20.59	20.90
3	8	4		20.32	20.74	20.54
3	8	7		20.40	20.72	20.57
3	15	0		20.44	20.71	20.72



LTE Band 2 Maximum Average Power [dBm]						
BW [MHz]	RB Size	RB Offset	Mod	Lowest	Middle	Highest
5	1	0	QPSK	22.29	22.60	22.57
5	1	12		22.27	22.45	22.53
5	1	24		22.20	22.37	22.40
5	12	0		21.18	21.41	21.38
5	12	6		21.19	21.41	21.46
5	12	11		21.20	21.37	21.41
5	25	0		21.15	21.35	21.39
5	1	0	16-QAM	21.55	21.83	21.87
5	1	12		21.58	21.87	21.90
5	1	24		21.47	21.62	21.71
5	12	0		20.21	20.36	20.35
5	12	6		20.17	20.35	20.39
5	12	11		20.18	20.29	20.36
5	25	0		20.22	20.38	20.40
10	1	0	QPSK	22.50	22.79	22.87
10	1	24		22.13	22.44	22.39
10	1	49		22.03	22.41	22.49
10	25	0		21.29	21.48	21.54
10	25	12		21.23	21.36	21.49
10	25	24		21.16	21.28	21.41
10	50	0		21.29	21.40	21.45
10	1	0	16-QAM	21.78	21.92	22.07
10	1	24		21.56	21.67	21.68
10	1	49		21.44	21.63	21.67
10	25	0		20.38	20.47	20.53
10	25	12		20.24	20.37	20.44
10	25	24		20.18	20.31	20.41
10	50	0		20.29	20.37	20.39



LTE Band 2 Maximum Average Power [dBm]						
BW [MHz]	RB Size	RB Offset	Mod	Lowest	Middle	Highest
15	1	0	QPSK	22.83	22.97	23.03
15	1	37		22.32	22.31	22.41
15	1	74		22.21	22.56	22.60
15	36	0		21.54	21.64	21.78
15	36	18		21.38	21.43	21.54
15	36	37		21.25	21.43	21.53
15	75	0		21.34	21.54	21.71
15	1	0	16-QAM	22.07	22.18	22.38
15	1	37		21.60	21.68	21.80
15	1	74		21.47	21.81	21.89
15	36	0		20.52	20.63	20.75
15	36	18		20.39	20.45	20.52
15	36	37		20.24	20.44	20.50
15	75	0		20.46	20.60	20.70
20	1	0	QPSK	23.10	23.19	23.36
20	1	49		22.40	22.60	22.70
20	1	99		22.45	22.68	22.68
20	50	0		21.71	21.72	21.93
20	50	24		21.55	21.59	21.90
20	50	49		21.45	21.57	21.70
20	100	0		21.55	21.63	21.80
20	1	0	16-QAM	22.33	22.38	22.37
20	1	49		21.59	21.70	21.72
20	1	99		21.66	21.93	21.92
20	50	0		20.66	20.71	20.95
20	50	24		20.50	20.53	20.74
20	50	49		20.42	20.53	20.68
20	100	0		20.60	20.60	20.82



LTE Band 25 Maximum Average Power [dBm]						
BW [MHz]	RB Size	RB Offset	Mod	Lowest	Middle	Highest
1.4	1	0	QPSK	23.09	23.05	23.13
1.4	1	2		22.50	22.53	22.70
1.4	1	5		22.57	22.85	22.51
1.4	3	0		22.43	22.47	22.47
1.4	3	1		22.42	22.44	22.45
1.4	3	2		22.40	22.39	22.43
1.4	6	0		21.64	21.68	21.78
1.4	1	0	16-QAM	22.54	22.39	22.46
1.4	1	2		21.92	21.90	22.18
1.4	1	5		21.72	22.15	22.15
1.4	3	0		21.49	21.38	21.51
1.4	3	1		21.45	21.37	21.47
1.4	3	2		21.41	21.35	21.44
1.4	6	0		20.62	20.84	21.04
3	1	0	QPSK	23.45	23.23	23.48
3	1	7		22.80	22.72	22.81
3	1	14		22.90	22.82	22.86
3	8	0		22.08	22.01	22.12
3	8	4		21.83	21.83	21.99
3	8	7		21.79	21.62	21.79
3	15	0		21.87	21.74	22.00
3	1	0	16-QAM	22.43	22.30	22.36
3	1	7		21.77	21.87	22.02
3	1	14		21.79	22.05	22.26
3	8	0		21.03	21.01	21.13
3	8	4		21.14	20.88	20.85
3	8	7		21.09	20.64	20.78
3	15	0		20.89	20.96	21.10



LTE Band 25 Maximum Average Power [dBm]						
BW [MHz]	RB Size	RB Offset	Mod	Lowest	Middle	Highest
5	1	0	QPSK	22.71	22.89	22.84
5	1	12		22.58	22.71	22.81
5	1	24		22.57	22.62	22.68
5	12	0		21.54	21.70	21.68
5	12	6		21.62	21.70	21.83
5	12	11		21.52	21.62	21.71
5	25	0		21.45	21.64	21.85
5	1	0	16-QAM	21.97	22.16	22.13
5	1	12		21.98	22.07	22.01
5	1	24		21.84	21.91	22.02
5	12	0		20.57	20.70	20.86
5	12	6		20.56	20.65	20.99
5	12	11		20.45	20.61	20.95
5	25	0		20.50	20.70	20.81
10	1	0	QPSK	22.91	23.10	23.20
10	1	24		22.55	22.80	22.76
10	1	49		22.45	22.76	22.77
10	25	0		21.68	21.85	21.94
10	25	12		21.67	21.78	21.77
10	25	24		21.41	21.59	21.67
10	50	0		21.57	21.76	21.88
10	1	0	16-QAM	22.21	22.42	22.41
10	1	24		21.91	22.11	22.06
10	1	49		21.75	22.06	22.08
10	25	0		20.68	20.87	20.96
10	25	12		20.68	20.76	20.81
10	25	24		20.43	20.61	20.69
10	50	0		20.51	20.72	20.84



LTE Band 25 Maximum Average Power [dBm]						
BW [MHz]	RB Size	RB Offset	Mod	Lowest	Middle	Highest
15	1	0	QPSK	23.22	23.22	23.33
15	1	37		22.62	22.72	22.85
15	1	74		22.59	22.85	22.69
15	36	0		21.96	21.95	22.02
15	36	18		21.73	21.74	21.92
15	36	37		21.65	21.79	21.80
15	75	0		21.69	21.82	21.95
15	1	0	16-QAM	22.58	22.49	22.54
15	1	37		22.06	22.05	22.18
15	1	74		21.79	22.15	22.26
15	36	0		20.97	20.95	21.03
15	36	18		20.74	20.78	20.98
15	36	37		20.64	20.77	20.77
15	75	0		20.78	20.96	21.10
20	1	0	QPSK	23.46	23.34	23.56
20	1	49		22.78	22.82	22.98
20	1	99		22.90	22.85	22.95
20	50	0		22.16	22.09	22.16
20	50	24		21.84	21.94	22.04
20	50	49		21.78	21.81	21.96
20	100	0		21.91	21.94	22.12
20	1	0	16-QAM	22.44	22.47	22.54
20	1	49		21.82	22.02	22.09
20	1	99		21.91	22.13	22.28
20	50	0		21.10	21.09	21.21
20	50	24		20.82	20.90	21.00
20	50	49		20.76	20.75	20.92
20	100	0		20.90	20.96	21.14



LTE Band 4 Maximum Average Power [dBm]						
BW [MHz]	RB Size	RB Offset	Mod	Lowest	Middle	Highest
1.4	1	0	QPSK	22.82	22.72	22.51
1.4	1	2		22.13	22.15	22.20
1.4	1	5		22.27	22.17	22.09
1.4	3	0		22.19	22.09	22.03
1.4	3	1		22.17	22.06	22.01
1.4	3	2		22.14	22.03	22.00
1.4	6	0		21.39	21.24	21.13
1.4	1	0	16-QAM	21.90	21.83	21.71
1.4	1	2		21.53	21.14	21.21
1.4	1	5		21.49	21.43	21.18
1.4	3	0		21.21	21.15	21.02
1.4	3	1		21.14	21.06	21.03
1.4	3	2		21.13	21.16	21.05
1.4	6	0		20.41	20.20	20.14
3	1	0	QPSK	23.02	22.83	22.78
3	1	7		22.45	22.29	22.12
3	1	14		22.44	22.19	22.22
3	8	0		21.74	21.44	21.42
3	8	4		21.41	21.26	21.13
3	8	7		21.35	21.13	21.16
3	15	0		21.40	21.18	21.19
3	1	0	16-QAM	22.29	22.03	22.05
3	1	7		21.39	21.36	21.31
3	1	14		21.56	21.57	21.30
3	8	0		20.68	20.36	20.34
3	8	4		20.45	20.37	20.14
3	8	7		20.40	20.23	20.18
3	15	0		20.39	20.36	20.26



LTE Band 4 Maximum Average Power [dBm]						
BW [MHz]	RB Size	RB Offset	Mod	Lowest	Middle	Highest
5	1	0	QPSK	22.56	22.42	22.25
5	1	12		22.33	22.23	22.06
5	1	24		22.29	22.19	22.01
5	12	0		21.36	21.24	21.02
5	12	6		21.33	21.18	21.08
5	12	11		21.34	21.09	21.05
5	25	0		21.32	21.15	21.03
5	1	0	16-QAM	21.76	21.64	21.44
5	1	12		21.77	21.53	21.49
5	1	24		21.55	21.33	21.26
5	12	0		20.33	20.18	20.00
5	12	6		20.28	20.16	20.00
5	12	11		20.25	20.12	20.02
5	25	0		20.30	20.18	20.02
10	1	0	QPSK	22.73	22.58	22.43
10	1	24		22.36	22.35	22.02
10	1	49		22.34	22.08	22.06
10	25	0		21.44	21.17	21.17
10	25	12		21.34	21.22	21.02
10	25	24		21.22	21.02	21.05
10	50	0		21.37	21.17	21.10
10	1	0	16-QAM	22.10	21.78	21.82
10	1	24		21.69	21.60	21.39
10	1	49		21.68	21.42	21.35
10	25	0		20.42	20.17	20.14
10	25	12		20.32	20.21	20.04
10	25	24		20.19	20.03	20.08
10	50	0		20.31	20.16	20.09



LTE Band 4 Maximum Average Power [dBm]						
BW [MHz]	RB Size	RB Offset	Mod	Lowest	Middle	Highest
15	1	0	QPSK	22.85	22.85	22.64
15	1	37		22.22	22.19	22.02
15	1	74		22.44	22.29	22.11
15	36	0		21.61	21.45	21.34
15	36	18		21.48	21.21	21.19
15	36	37		21.27	21.24	21.03
15	75	0		21.48	21.28	21.17
15	1	0	16-QAM	22.06	21.97	21.86
15	1	37		21.61	21.33	21.35
15	1	74		21.69	21.54	21.37
15	36	0		20.55	20.45	20.26
15	36	18		20.44	20.20	20.15
15	36	37		20.22	20.19	20.05
15	75	0		20.49	20.28	20.28
20	1	0	QPSK	23.10	22.98	22.90
20	1	49		22.48	22.30	22.25
20	1	99		22.56	22.37	22.34
20	50	0		21.75	21.58	21.44
20	50	24		21.46	21.28	21.23
20	50	49		21.41	21.28	21.21
20	100	0		21.57	21.37	21.25
20	1	0	16-QAM	22.32	22.23	22.10
20	1	49		21.57	21.49	21.31
20	1	99		21.75	21.59	21.48
20	50	0		20.77	20.56	20.43
20	50	24		20.47	20.38	20.24
20	50	49		20.40	20.33	20.23
20	100	0		20.59	20.37	20.27



LTE Band 5 Maximum Average Power [dBm]						
BW [MHz]	RB Size	RB Offset	Mod	Lowest	Middle	Highest
1.4	1	0	QPSK	22.45	22.49	22.27
1.4	1	2		22.39	22.37	22.41
1.4	1	5		22.43	22.24	22.41
1.4	3	0		22.21	22.00	22.31
1.4	3	1		22.18	22.01	22.25
1.4	3	2		22.15	22.15	22.27
1.4	6	0		21.38	21.24	21.45
1.4	1	0	16-QAM	21.74	21.63	21.56
1.4	1	2		21.92	21.85	21.81
1.4	1	5		21.56	21.61	21.64
1.4	3	0		21.50	21.45	21.43
1.4	3	1		21.45	21.53	21.48
1.4	3	2		21.48	21.58	21.49
1.4	6	0		20.34	20.33	20.41
3	1	0	QPSK	22.46	22.60	22.46
3	1	7		22.54	22.46	22.52
3	1	14		22.52	22.28	22.29
3	8	0		21.41	21.33	21.42
3	8	4		21.54	21.39	21.42
3	8	7		21.61	21.30	21.28
3	15	0		21.43	21.53	21.29
3	1	0	16-QAM	21.71	21.73	21.73
3	1	7		21.81	21.74	21.60
3	1	14		21.74	21.55	21.77
3	8	0		20.41	20.44	20.38
3	8	4		20.39	20.29	20.33
3	8	7		20.43	20.21	20.29
3	15	0		20.44	20.33	20.43



LTE Band 5 Maximum Average Power [dBm]						
BW [MHz]	RB Size	RB Offset	Mod	Lowest	Middle	Highest
5	1	0	QPSK	22.46	22.49	22.46
5	1	12		22.47	22.37	22.44
5	1	24		22.50	22.41	22.47
5	12	0		21.39	21.46	21.44
5	12	6		21.48	21.52	21.45
5	12	11		21.50	21.52	21.40
5	25	0		21.52	21.41	21.46
5	1	0	16-QAM	21.74	21.75	21.73
5	1	12		21.94	21.88	21.87
5	1	24		21.76	21.70	21.79
5	12	0		20.34	20.45	20.42
5	12	6		20.39	20.42	20.42
5	12	11		20.42	20.41	20.42
5	25	0		20.51	20.36	20.46
10	1	0	QPSK	22.55	22.65	22.51
10	1	24		22.55	22.63	22.56
10	1	49		22.56	22.38	22.45
10	25	0		21.56	21.52	21.45
10	25	12		21.58	21.44	21.42
10	25	24		21.62	21.44	21.44
10	50	0		21.54	21.53	21.48
10	1	0	16-QAM	21.88	21.91	21.76
10	1	24		21.82	21.93	21.71
10	1	49		21.85	21.68	21.80
10	25	0		20.57	20.51	20.42
10	25	12		20.59	20.44	20.41
10	25	24		20.59	20.39	20.43
10	50	0		20.52	20.52	20.47



LTE Band 7 Maximum Average Power [dBm]						
BW [MHz]	RB Size	RB Offset	Mod	Lowest	Middle	Highest
5	1	0	QPSK	22.27	22.26	22.16
5	1	12		22.32	22.22	22.08
5	1	24		22.24	22.13	22.08
5	12	0		21.23	21.22	21.00
5	12	6		21.38	21.31	21.07
5	12	11		21.33	21.23	21.06
5	25	0		21.32	21.27	21.05
5	1	0	16-QAM	21.59	21.51	21.29
5	1	12		21.75	21.74	21.48
5	1	24		21.54	21.47	21.31
5	12	0		20.25	20.23	20.10
5	12	6		20.34	20.29	20.11
5	12	11		20.26	20.16	20.08
5	25	0		20.32	20.25	20.05
10	1	0	QPSK	22.26	22.23	22.11
10	1	24		22.34	22.31	22.08
10	1	49		22.17	22.04	22.00
10	25	0		21.33	21.22	21.00
10	25	12		21.31	21.29	21.08
10	25	24		21.21	21.14	21.09
10	50	0		21.26	21.20	21.06
10	1	0	16-QAM	21.55	21.70	21.68
10	1	24		21.57	21.65	21.45
10	1	49		21.49	21.39	21.26
10	25	0		20.30	20.19	20.03
10	25	12		20.29	20.26	20.15
10	25	24		20.23	20.13	20.07
10	50	0		20.25	20.20	20.10



LTE Band 7 Maximum Average Power [dBm]						
BW [MHz]	RB Size	RB Offset	Mod	Lowest	Middle	Highest
15	1	0	QPSK	22.39	22.38	22.33
15	1	37		22.23	22.38	22.08
15	1	74		22.01	22.04	22.00
15	36	0		21.34	21.49	21.35
15	36	18		21.37	21.50	21.24
15	36	37		21.15	21.26	21.12
15	75	0		21.22	21.39	21.23
15	1	0	16-QAM	21.59	21.61	21.45
15	1	37		21.61	21.75	21.55
15	1	74		21.26	21.31	21.19
15	36	0		20.33	20.42	20.31
15	36	18		20.37	20.43	20.23
15	36	37		20.16	20.21	20.13
15	75	0		20.25	20.35	20.21
20	1	0	QPSK	22.28	22.41	22.21
20	1	49		22.21	22.37	22.37
20	1	99		22.00	22.10	22.11
20	50	0		21.26	21.28	21.31
20	50	24		21.32	21.40	21.36
20	50	49		21.17	21.19	21.15
20	100	0		21.21	21.23	21.26
20	1	0	16-QAM	21.38	21.45	21.27
20	1	49		21.50	21.60	21.57
20	1	99		21.20	21.02	21.09
20	50	0		20.28	20.27	20.28
20	50	24		20.32	20.41	20.30
20	50	49		20.17	20.18	20.11
20	100	0		20.20	20.23	20.26



LTE Band 12 Maximum Average Power [dBm]						
BW [MHz]	RB Size	RB Offset	Mod	Lowest	Middle	Highest
1.4	1	0	QPSK	22.04	22.46	22.50
1.4	1	2		22.06	22.42	22.25
1.4	1	5		22.13	22.47	22.15
1.4	3	0		22.00	22.35	22.02
1.4	3	1		22.01	22.36	22.10
1.4	3	2		22.01	22.27	22.13
1.4	6	0		21.16	21.38	21.46
1.4	1	0	16-QAM	21.36	21.57	21.61
1.4	1	2		21.62	21.91	21.91
1.4	1	5		21.33	21.82	21.78
1.4	3	0		21.15	21.70	21.65
1.4	3	1		21.20	21.78	21.61
1.4	3	2		21.11	21.76	21.67
1.4	6	0		20.15	20.33	20.49
3	1	0	QPSK	22.39	22.54	22.59
3	1	7		22.22	22.56	22.48
3	1	14		22.16	22.41	22.46
3	8	0		21.12	21.30	21.46
3	8	4		21.04	21.52	21.33
3	8	7		21.15	21.34	21.43
3	15	0		21.03	21.37	21.29
3	1	0	16-QAM	21.49	21.67	21.72
3	1	7		21.45	21.71	21.63
3	1	14		21.51	21.77	21.79
3	8	0		20.15	20.40	20.36
3	8	4		20.10	20.50	20.25
3	8	7		20.10	20.27	20.27
3	15	0		20.21	20.38	20.30



LTE Band 12 Maximum Average Power [dBm]						
BW [MHz]	RB Size	RB Offset	Mod	Lowest	Middle	Highest
5	1	0	QPSK	22.20	22.52	22.61
5	1	12		22.24	22.45	22.59
5	1	24		22.26	22.60	22.69
5	12	0		21.16	21.50	21.55
5	12	6		21.23	21.47	21.65
5	12	11		21.24	21.51	21.65
5	25	0		21.24	21.56	21.66
5	1	0	16-QAM	21.45	21.77	21.79
5	1	12		21.68	21.94	21.96
5	1	24		21.49	21.85	21.93
5	12	0		20.12	20.39	20.55
5	12	6		20.15	20.34	20.59
5	12	11		20.17	20.39	20.54
5	25	0		20.18	20.53	20.56
10	1	0	QPSK	22.55	22.59	22.72
10	1	24		22.30	22.62	22.60
10	1	49		22.29	22.48	22.60
10	25	0		21.20	21.49	21.50
10	25	12		21.21	21.55	21.45
10	25	24		21.27	21.45	21.49
10	50	0		21.22	21.51	21.43
10	1	0	16-QAM	21.51	21.73	21.81
10	1	24		21.51	21.86	21.82
10	1	49		21.58	21.79	21.89
10	25	0		20.18	20.46	20.46
10	25	12		20.20	20.55	20.43
10	25	24		20.28	20.43	20.47
10	50	0		20.21	20.49	20.40



LTE Band 17 Maximum Average Power [dBm]						
BW [MHz]	RB Size	RB Offset	Mod	Lowest	Middle	Highest
5	1	0	QPSK	22.37	22.60	22.61
5	1	12		22.38	22.50	22.62
5	1	24		22.42	22.59	22.68
5	12	0		21.38	21.49	21.57
5	12	6		21.41	21.50	21.67
5	12	11		21.45	21.52	21.67
5	25	0		21.39	21.53	21.67
5	1	0	16-QAM	21.54	21.79	21.84
5	1	12		21.86	21.95	22.01
5	1	24		21.67	21.85	21.95
5	12	0		20.31	20.41	20.56
5	12	6		20.26	20.45	20.64
5	12	11		20.30	20.48	20.55
5	25	0		20.39	20.44	20.58
10	1	0	QPSK	22.62	22.66	22.72
10	1	24		22.64	22.60	22.66
10	1	49		22.51	22.60	22.68
10	25	0		21.53	21.49	21.62
10	25	12		21.57	21.53	21.69
10	25	24		21.55	21.50	21.63
10	50	0		21.51	21.49	21.65
10	1	0	16-QAM	21.80	21.82	21.85
10	1	24		21.93	21.89	21.91
10	1	49		21.86	21.95	21.97
10	25	0		20.50	20.49	20.62
10	25	12		20.50	20.49	20.65
10	25	24		20.52	20.48	20.60
10	50	0		20.46	20.44	20.64



LTE Band 41 Maximum Average Power [dBm]						
BW [MHz]	RB Size	RB Offset	Mod	Lowest	Middle	Highest
5	1	0	QPSK	21.29	21.50	21.60
5	1	12		21.18	21.39	21.46
5	1	24		21.06	21.30	21.38
5	12	0		20.45	20.51	20.64
5	12	6		20.46	20.48	20.61
5	12	11		20.41	20.31	20.58
5	25	0		20.43	20.39	20.62
5	1	0	16-QAM	20.70	20.58	20.88
5	1	12		20.89	20.91	20.99
5	1	24		20.76	20.62	20.83
5	12	0		19.44	19.51	19.63
5	12	6		19.49	19.58	19.73
5	12	11		19.42	19.33	19.58
5	25	0		19.55	19.55	19.66
10	1	0	QPSK	21.55	21.43	21.52
10	1	24		21.62	21.52	21.62
10	1	49		21.47	21.33	21.47
10	25	0		20.48	20.47	20.62
10	25	12		20.53	20.49	20.52
10	25	24		20.52	20.30	20.48
10	50	0		20.53	20.40	20.58
10	1	0	16-QAM	20.84	20.76	20.89
10	1	24		20.80	20.75	20.94
10	1	49		20.72	20.65	20.75
10	25	0		19.59	19.45	19.67
10	25	12		19.59	19.49	19.64
10	25	24		19.61	19.40	19.63
10	50	0		19.49	19.40	19.62



LTE Band 41 Maximum Average Power [dBm]						
BW [MHz]	RB Size	RB Offset	Mod	Lowest	Middle	Highest
15	1	0	QPSK	21.68	21.50	21.66
15	1	37		21.65	21.55	21.39
15	1	74		21.43	21.19	21.32
15	36	0		20.62	20.50	20.50
15	36	18		20.62	20.53	20.63
15	36	37		20.54	20.31	20.47
15	75	0		20.60	20.32	20.51
15	1	0	16-QAM	20.73	20.60	20.88
15	1	37		20.72	20.64	20.79
15	1	74		20.55	20.28	20.54
15	36	0		19.64	19.48	19.57
15	36	18		19.56	19.46	19.62
15	36	37		19.47	19.31	19.47
15	75	0		19.57	19.35	19.49
20	1	0	QPSK	21.70	21.36	21.56
20	1	49		21.65	21.45	21.44
20	1	99		21.15	21.09	21.12
20	50	0		20.63	20.47	20.64
20	50	24		20.70	20.51	20.64
20	50	49		20.38	20.27	20.47
20	100	0		20.60	20.33	20.50
20	1	0	16-QAM	20.74	20.51	20.84
20	1	49		20.84	20.70	20.73
20	1	99		20.28	20.22	20.39
20	50	0		19.65	19.48	19.70
20	50	24		19.68	19.56	19.60
20	50	49		19.44	19.33	19.35
20	100	0		19.61	19.30	19.58



## LTE Band 2

### Peak-to-Average Ratio

Mode	LTE Band 2 / 20MHz				
Mod.	QPSK		16QAM		Limit: 13dB
RB Size	1RB	Full RB	1RB	Full RB	Result
Lowest CH	3.77	4.52	4.35	5.57	<b>PASS</b>
Middle CH	3.16	4.81	3.80	5.94	
Highest CH	3.45	4.93	4.20	5.77	