



# FCC RF Test Report

**APPLICANT** : Motorola Mobility, LLC  
**EQUIPMENT** : Mobile Cellular Phone  
**BRAND NAME** : Motorola  
**MODEL NAME** : 4036  
**FCC ID** : IHDT56UA1  
**STANDARD** : FCC Part 15 Subpart C §15.225  
**CLASSIFICATION** : (DXX) Low Power Communication Device Transmitter

The testing was completed on Jun. 13, 2015. We, SPORTON INTERNATIONAL INC., would like to declare that the tested sample has been evaluated in accordance with the test procedures and has been in compliance with the applicable technical standards.

The test results in this report apply exclusively to the tested model / sample. Without written approval of SPORTON INTERNATIONAL INC., the test report shall not be reproduced except in full.

---

Reviewed by: Joseph Lin / Supervisor

---

Approved by: Jones Tsai / Manager



**SPORTON INTERNATIONAL INC.**

**No. 52, Hwa Ya 1<sup>st</sup> Rd., Hwa Ya Technology Park, Kwei-Shan District, Tao Yuan City, Taiwan, R.O.C.**



Table of Contents

SUMMARY OF THE TEST RESULT .....4
1. GENERAL INFORMATION.....5
1.1 Applicant .....5
1.2 Manufacturer.....5
1.3 Feature of Equipment Under Test .....5
1.4 Product Details.....6
1.5 Modification of EUT.....6
1.6 Testing Location .....6
1.7 Applicable Standards .....7
1.8 Test Modes.....7
1.9 Test Configurations.....7
1.10 Table for Supporting Units .....8
2. CONDUCTED EMISSION TEST.....9
2.1 Measuring Instruments .....9
2.2 Test setup .....9
2.3 Test Result of Conducted Emission Test.....9
2.4 AC Power Line Conducted Emissions Measurement .....10
3. CONDUCTED TEST ITEMS .....11
3.1 Measuring Instruments .....11
3.2 Test Setup .....11
3.3 Test Result of Conducted Test Items.....11
3.4 20dB Spectrum Bandwidth Measurement .....12
3.5 Frequency Stability Measurement .....12
4. RADIATED TEST ITEMS.....13
4.1 Measuring Instruments .....13
4.2 Test Setup .....13
4.3 Test Result of Radiated Test Items .....13
4.4 Field Strength of Fundamental Emissions and Mask Measurement .....14
4.5 Radiated Emissions Measurement .....15
5. LIST OF MEASURING EQUIPMENT .....17
APPENDIX A. TEST RESULTS OF CONDUCTED EMISSION TEST
APPENDIX B. TEST RESULTS OF CONDUCTED TEST ITEMS
B.1 Test Result of 20dB Spectrum Bandwidth
B.2 Test Result of Frequency Stability
APPENDIX C. TEST RESULTS OF RADIATED TEST ITEMS
C.1 Test Result of Field Strength of Fundamental Emissions
C.2 Results of Radiated Emissions (9 kHz~30MHz)
C.3 Results of Radiated Emissions (30MHz~1GHz)





### SUMMARY OF THE TEST RESULT

Applied Standard: 47 CFR FCC Part 15 Subpart C				
Part	FCC Rule	Description of Test	Result	Under Limit
3.1	15.207	AC Power Line Conducted Emissions	Complies	6.90 dB at 13.558MHz
3.2	15.225(a)(b)(c)	Field Strength of Fundamental Emissions	Complies	65.12 dB at 13.560 MHz
3.3	2.1049	20dB Spectrum Bandwidth	Complies	-
3.4	15.225(d) 15.209	Radiated Emissions	Complies	9.76 dB at 208.200 MHz
3.5	15.225(e)	Frequency Stability	Complies	-
3.6	15.203	Antenna Requirements	Complies	-

Test Items	Uncertainty	Remark
AC Power Line Conducted Emissions	±2.26dB	Confidence levels of 95%
Radiated Emissions (30MHz~1000MHz)	±4.70dB	Confidence levels of 95%



# 1. GENERAL INFORMATION

## 1.1 Applicant

**Motorola Mobility, LLC**

222 W Merchandise Mart Plaza, Suite 1800, Chicago, IL 60654, United States

## 1.2 Manufacturer

**Motorola Mobility, LLC**

222 W Merchandise Mart Plaza, Suite 1800, Chicago, IL 60654, United States

## 1.3 Feature of Equipment Under Test

Product Feature	
Equipment	Mobile Cellular Phone
Brand Name	Motorola
FCC Model Name	4036
FCC ID	IHDT56UA1
IMEI Code	990005740001756 990005740025664
EUT supports Radios application	CDMA/EV-DO/GSM/EGPRS/WCDMA/HSPA/LTE/NFC 2.4GHz WLAN 11b/g/n HT20 WLAN 11ac VHT20 5GHz WLAN 11a/n HT20/HT40 WLAN 11ac VHT20/VHT40/VHT80 Bluetooth v3.0 EDR Bluetooth v4.1 - LE
HW Version	P2
EUT Stage	Identical Prototype

Accessory List	
AC Adapter 1	Brand Name : Motorola
	Model Name : SPN5886A
Battery	Brand Name : Motorola
	Model Name : FB55
Earphone	Brand Name : Motorola
	Model Name : 89719N



### 1.4 Product Details

Items	Description
Tx/Rx Frequency Range	13.553 ~ 13.567MHz
Channel Number	1
20dBW	2.640KHz
99%OBW	2.240KHz
Antenna Type	Coil / embeded Antenna
Type of Modulation	ASK

Remark: The above EUT's information was declared by manufacturer. Please refer to the specifications or user's manual for more detailed description.

### 1.5 Modification of EUT

No modifications are made to the EUT during all test items.

### 1.6 Testing Location

Sporton Lab is accredited to ISO 17025 by Taiwan Accreditation Foundation (TAF code : 1190) and the FCC designation No. TW1022 under the FCC 2.948(e) by Mutual Recognition Agreement (MRA) in FCC Test.

Test Site	SPORTON INTERNATIONAL INC.		
Test Site Location	No. 52, Hwa Ya 1 <sup>st</sup> Rd., Hwa Ya Technology Park, Kwei-Shan District, Tao Yuan City, Taiwan, R.O.C. TEL: +886-3-3273456 / FAX: +886-3-3284978		
Test Site No.	Sporton Site No.		
	TH03-HY	CO05-HY	03CH07-HY
Test Engineer	Danny Chen	Eric Jeng	Nick Yu and James Chiu
Temperature	22~24°C	23~25°C	20~22°C
Relative Humidity	53~55%	58~59%	50~55%

Note: The test site complies with ANSI C63.4 2009 requirement.

### 1.7 Applicable Standards

According to the specifications of the manufacturer, the EUT must comply with the requirements of the following standards:

- ♦ FCC Part 15 Subpart C §15.225
- ♦ ANSI C63.10-2009

### 1.8 Test Modes

Investigation has been done on all the possible configurations for searching the worst cases. The following table is a list of the test modes shown in this test report.

Test Items	
AC Power Line Conducted Emissions	Field Strength of Fundamental Emissions
20dB Spectrum Bandwidth	Frequency Stability
Radiated Emissions 9kHz~30MHz	Radiated Emissions 30MHz~1GHz
<b>Note:</b>	
1. The EUT was programmed to be in continuously transmitting mode.	
2. The ancillary equipment, NFC card, is used to make the EUT (NFC) continuously transmit at 13.56MHz and is placed around 3 cm gap to the EUT.	

### 1.9 Test Configurations

**<AC Conducted Emissions>**

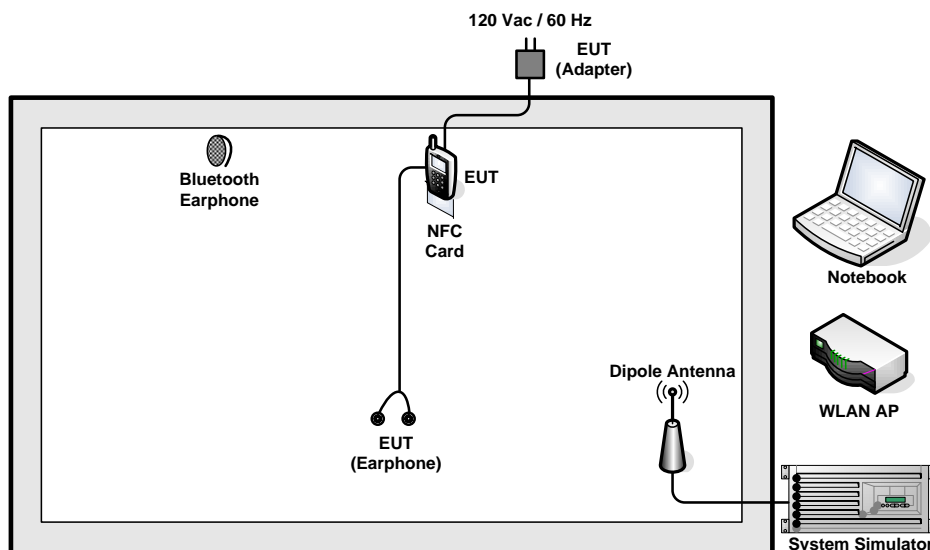

<For Fundamental Emissions and Mask and Radiated Emissions Measurement>

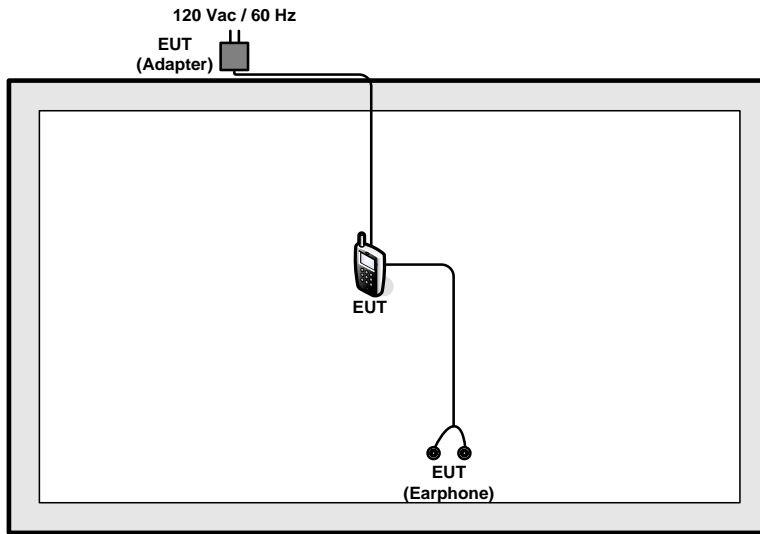

**1.10 Table for Supporting Units**

Support Unit	Manufacturer	Model	FCC ID	Data Cable	Power Cord
System Simulator	Anritsu	MT8820C	N/A	N/A	Unshielded, 1.8 m
WLAN AP	D-Link	DIR-865L	KA2IR865LA1	N/A	Unshielded, 1.8 m
Notebook	DELL	Latitude E6320	FCC DoC/ Contains FCC ID: QDS-BRCM1054	N/A	AC I/P: Unshielded, 1.2 m DC O/P: Shielded, 1.8 m
Bluetooth Earphone	Sony Ericsson	MW600	PY7DDA-2029	N/A	N/A
NFC Card	Metro Taipei	Easy Card	N/A	N/A	N/A
SD Card	SanDisk	MicroSD HC	FCC DoC	N/A	N/A

## 2. CONDUCTED EMISSION TEST

### 2.1 Measuring Instruments

See list of measuring instruments of this test report.

### 2.2 Test setup

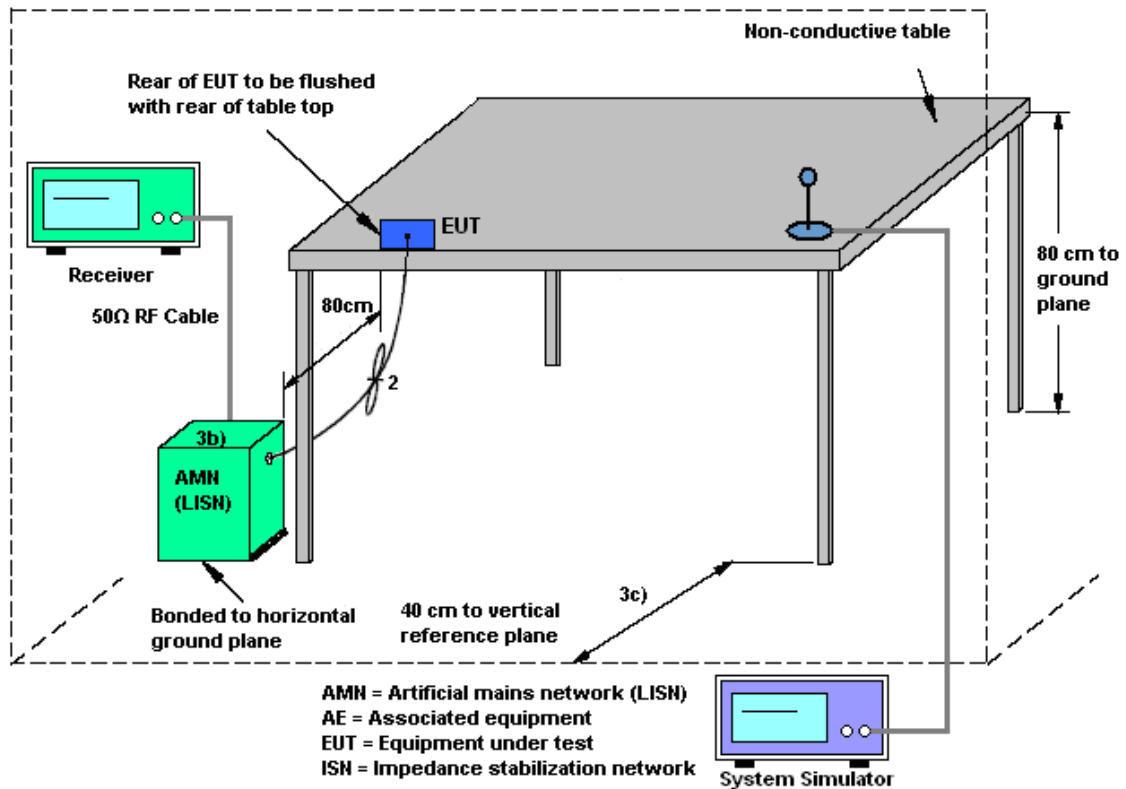

### 2.3 Test Result of Conducted Emission Test

Please refer to Appendix B.



## 2.4 AC Power Line Conducted Emissions Measurement

### 2.4.1 Limit

For equipment that is designed to be connected to the public utility (AC) power line, the radio frequency voltage that is conducted back onto the AC power line on any frequency or frequencies within the band 150 kHz to 30 MHz shall not exceed the limits in the following table.

Frequency of Emission (MHz)	Conducted Limit (dB $\mu$ V)	
	Quasi-Peak	Average
0.15-0.5	66 to 56*	56 to 46*
0.5-5	56	46
5-30	60	50

\*Decreases with the logarithm of the frequency.

### 2.4.2 Test Procedures

1. The EUT was placed 0.4 meter from the conducting wall of the shielding room, and it was kept at least 80 centimeters from any other grounded conducting surface.
2. Connect EUT to the power mains through a line impedance stabilization network (LISN).
3. All the support units are connecting to the other LISN.
4. The LISN provides 50 ohm coupling impedance for the measuring instrument.
5. The FCC states that a 50 ohm, 50 microhenry LISN should be used.
6. Both sides of AC line were checked for maximum conducted interference.
7. The frequency range from 150 kHz to 30 MHz was searched.
8. Set the test-receiver system to Peak Detect Function and specified bandwidth (IF Bandwidth = 9kHz) with Maximum Hold Mode. Then measurement is also conducted by Average Detector and Quasi-Peak Detector Function respectively.

### 3. CONDUCTED TEST ITEMS

#### 3.1 Measuring Instruments

See list of measuring instruments of this test report.

#### 3.2 Test Setup

##### 3.2.1 20dB Spectrum Bandwidth

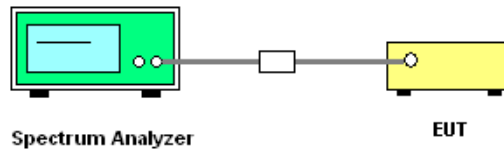

##### 3.2.2 Frequency Stability

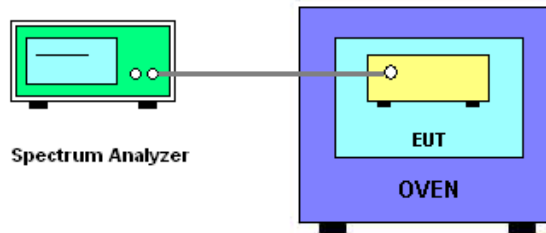

#### 3.3 Test Result of Conducted Test Items

Please refer to Appendix C.



### **3.4 20dB Spectrum Bandwidth Measurement**

#### **3.4.1 Limit**

Intentional radiators must be designed to ensure that the 20 dB bandwidth of the emissions in the specific band 13.553~13.567MHz

#### **3.4.2 Test Procedures**

1. The transmitter output (antenna port) was connected to the spectrum analyzer in peak Max hold mode.
2. The resolution bandwidth of 1 kHz and the video bandwidth of 3 kHz were used.
3. Measured the spectrum width with power higher than 20dB below carrier.

### **3.5 Frequency Stability Measurement**

#### **3.5.1 Limit**

The frequency tolerance of the carrier signal shall be maintained within +/- 0.01% (100ppm) of the operating frequency over a temperature variation of -20 degrees to +50 degrees C at normal supply voltage, and for a variation in the primary supply voltage from 85% to 115% of the rated supply voltage at a temperature of 20 degrees C. For battery operated equipment, the equipment tests shall be performed using a new battery.

#### **3.5.2 Test Procedures**

1. The transmitter output (antenna port) was connected to the spectrum analyzer.
2. EUT have transmitted signal and fixed channelize.
3. Set the spectrum analyzer span to view the entire emissions bandwidth.
4. Set RBW = 1 kHz, VBW = 3 kHz with peak detector and maxhold settings.
5. The  $f_c$  is declaring of channel frequency. Then the frequency error formula is  $(f_c-f)/f_c \times 10^6$  ppm and the limit is less than  $\pm 100$ ppm.
6. Extreme temperature rule is -20°C~50°C.

## 4. RADIATED TEST ITEMS

### 4.1 Measuring Instruments

See list of measuring instruments of this test report.

### 4.2 Test Setup

#### 4.2.1 For radiated emissions below 30MHz

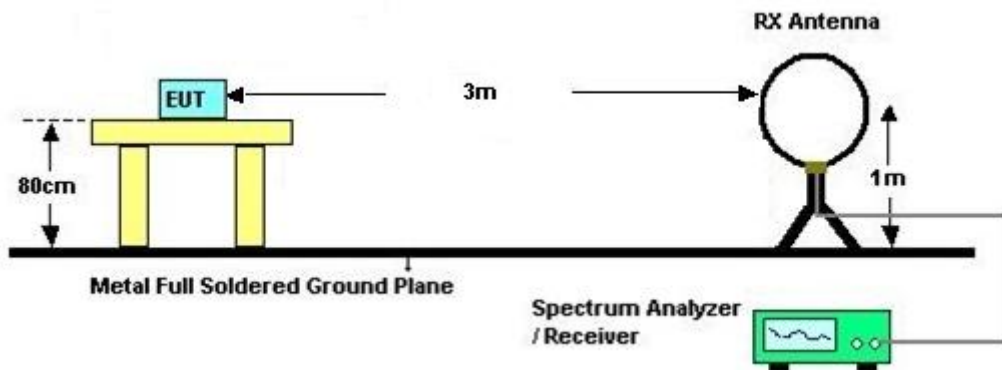

#### 4.2.2 For radiated emissions above 30MHz

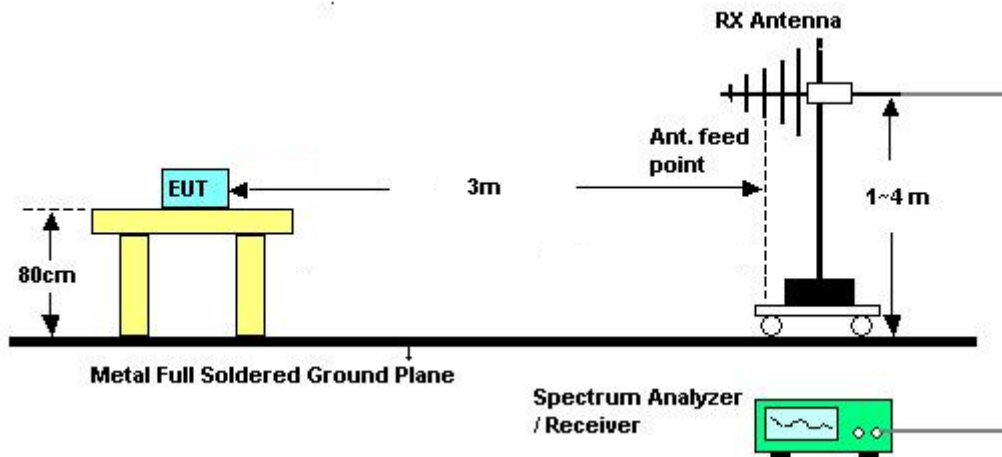

### 4.3 Test Result of Radiated Test Items

Please refer to Appendix D.



#### 4.4 Field Strength of Fundamental Emissions and Mask Measurement

##### 4.4.1 Limit

Rules and specifications	CFR 47 Part 15 section 15.225(a)-(d)			
Description	Compliance with the spectrum mask is tested using a spectrum analyzer with RBW set to a 9kHz for the band 13.553~13.567MHz			
Freq. of Emission (MHz)	Field Strength (μV/m) at 30m	Field Strength (dBμV/m) at 30m	Field Strength (dBμV/m) at 10m	Field Strength (dBμV/m) at 3m
1.705~13.110	30	29.5	48.58	69.5
13.110~13.410	106	40.5	59.58	80.5
13.410~13.553	334	50.5	69.58	90.5
13.553~13.567	15848	84.0	103.08	124.0
13.567~13.710	334	50.5	69.58	90.5
13.710~14.010	106	40.5	59.58	80.5
14.010~30.000	30	29.5	48.58	69.5

##### 4.4.2 Test Procedures

1. Configure the EUT according to ANSI C63.4. The EUT was placed on the top of the turntable 0.8 meter above ground. The phase center of the loop receiving antenna mounted antenna tower was placed 3 meters far away from the turntable.
2. Power on the EUT and all the supporting units. The turntable was rotated by 360 degrees to determine the position of the highest radiation.
3. The height of the receiving antenna was fixed at one meter above ground to find the maximum emissions field strength.
4. For Fundamental emissions, use the receiver to measure QP reading.
5. When the radiated emissions limits are expressed in terms of the average value of the emissions, and pulsed operation is employed, the measurement field strength shall be determined by averaging over one complete pulse train, including blanking intervals, as long as the pulse train does not exceed 0.1 seconds. As an alternative (provided the transmitter operates for longer than 0.1 seconds) or in cases where the pulse train exceeds 0.1 seconds, the measured field strength shall be determined from the average absolute voltage during a 0.1 second interval during which the field strength is at its maximum value.
6. Compliance with the spectrum mask is tested using a spectrum analyzer with RBW set to a 9kHz for the band 13.553~13.567MHz.

Note: Emission level (dBμV/m) = 20 log Emission level (μV/m).



## 4.5 Radiated Emissions Measurement

### 4.5.1 Limit

The field strength of any emissions which appear outside of 13.553~13.567MHz band shall not exceed the general radiated emissions limits.

Frequencies (MHz)	Field Strength ( $\mu\text{V/m}$ )	Measurement Distance (meters)
0.009~0.490	2400/F(kHz)	300
0.490~1.705	24000/F(kHz)	30
1.705~30.0	30	30
30~88	100	3
88~216	150	3
216~960	200	3
Above 960	500	3

### 4.5.2 Measuring Instrument Setting

The following table is the setting of receiver.

Receiver Parameter	Setting
Attenuation	Auto
Frequency Range: 9kHz~150kHz	RBW 200Hz for QP
Frequency Range: 150kHz~30MHz	RBW 9kHz for QP
Frequency Range: 30MHz~1000MHz	RBW 120kHz for Peak

**Note:** The emission limits shown in the above table are based on measurements employing a CISPR quasi-peak detector except for the frequency bands 9-90 kHz, 110-490 kHz. Radiated emission limits in these two bands are based on measurements employing an average detector.



### 4.5.3 Test Procedures

1. Configure the EUT according to ANSI C63.4. The EUT was placed on the top of the turntable 0.8 meter above ground. The phase center of the receiving antenna mounted on the top of a height-variable antenna tower was placed 3 meters far away from the turntable.
2. Power on the EUT and all the supporting units. The turntable was rotated by 360 degrees to determine the position of the highest radiation.
3. The height of the broadband receiving antenna was varied between one meter and four meters above ground to find the maximum emissions field strength of both horizontal and vertical polarization.
4. For each suspected emissions, the antenna tower was scan (from 1 M to 4 M) and then the turntable was rotated (from 0 degree to 360 degrees) to find the maximum reading.
5. Set the test-receiver system to Peak or CISPR quasi-peak Detect Function with specified bandwidth under Maximum Hold Mode.
6. When the radiated emissions limits are expressed in terms of the average value of the emissions, and pulsed operation is employed, the measurement field strength shall be determined by averaging over one complete pulse train, including blanking intervals, as long as the pulse train does not exceed 0.1 seconds. As an alternative (provided the transmitter operates for longer than 0.1 seconds) or in cases where the pulse train exceeds 0.1 seconds, the measured field strength shall be determined from the average absolute voltage during a 0.1 second interval during which the field strength is at its maximum value.
7. In case the emission is lower than 30MHz, loop antenna has to be used for measurement and the recorded data should be QP measured by receiver. Antenna Requirements

### 4.5.4 Limit

Except for special regulations, the Low-power Radio-frequency Devices must not be equipped with any jacket for installing an antenna with extension cable. An intentional radiator shall be designed to ensure that no antenna other than that furnished by the responsible party shall be used with the device. The use of a permanently attached antenna or of an antenna that uses a unique coupling to the intentional radiator shall be considered sufficient to comply with the provisions of this Section. The manufacturer may design the unit so that the user can replace a broken antenna, but the use of a standard antenna jack or electrical connector is prohibited.

### 4.5.5 Antenna Anti-Replacement Construction

An embedded-in antenna design is used.



## 5. LIST OF MEASURING EQUIPMENT

Instrument	Manufacturer	Model No.	Serial No.	Characteristics	Calibration Date	Test Date	Due Date	Remark
Spectrum Analyzer	Rohde & Schwarz	FSP30	101329	9kHz~30GHz	Jun. 14, 2014	Jun. 05, 2015	Jun. 13, 2015	Conducted (TH03-HY)
Programmable Power Supply	GW Instek	PSS-2005	EL883644	Voltage:0~20V; Current:0~5A	Dec. 01, 2014	Jun. 05, 2015	Nov. 30, 2015	Conducted (TH03-HY)
Temperature Chamber	ESPEC	SU-641	92013721	-30~70°C	Dec. 01, 2014	Jun. 05, 2015	Nov. 30, 2015	Conducted (TH03-HY)
EMI Test Receiver	Rohde & Schwarz	ESCS 30	100356	9kHz – 2.75GHz	Dec. 01, 2014	Jun. 02, 2015	Nov. 30, 2015	Conduction (CO05-HY)
LISN	Rohde & Schwarz	ENV216	100080	9kHz~30MHz	Dec. 02, 2014	Jun. 02, 2015	Dec. 01, 2015	Conduction (CO05-HY)
AC Power Source	ChainTek	APC-1000W	N/A	N/A	N/A	Jun. 02, 2015	N/A	Conduction (CO05-HY)
Bilog Antenna	Schaffner	CBL6111C	2726	30MHz ~ 1GHz	Sep. 27, 2014	Jun. 12, 2015 ~ Jun. 13, 2015	Sep. 26, 2015	Radiation (03CH07-HY)
Loop Antenna	Rohde & Schwarz	HFH2-Z2	100315	9 kHz~30 MHz	Jul. 28, 2014	Jun. 12, 2015 ~ Jun. 13, 2015	Jul. 27, 2015	Radiation (03CH07-HY)
Preamplifier	COM-POWER	PA-103A	161241	10MHz-1000MHz	Mar. 12, 2015	Jun. 12, 2015 ~ Jun. 13, 2015	Mar. 11, 2016	Radiation (03CH07-HY)
Signal Analyzer	Rohde & Schwarz	FSV 30	101749	10Hz~30GHz	Mar. 10, 2015	Jun. 12, 2015 ~ Jun. 13, 2015	Mar. 09, 2016	Radiation (03CH07-HY)
Antenna Mast	Max-Full	MFA520BS	N/A	1m~4m	N/A	Jun. 12, 2015 ~ Jun. 13, 2015	N/A	Radiation (03CH07-HY)
Turn Table	ChainTek	Chaintek 3000	N/A	0~360 degree	N/A	Jun. 12, 2015 ~ Jun. 13, 2015	N/A	Radiation (03CH07-HY)



## Appendix A. Test Results of Conducted Emission Test

Test Mode :	NFC Tx	Test Voltage :	120Vac / 60Hz
Function Type :	GSM850 Idle + Bluetooth Link + WLAN Link + Adapter + NFC Tx + Earphone		

**Final Result : Quasi-Peak**

Frequency (MHz)	Quasi-Peak (dBµV)	Filter	Line	Corr. (dB)	Margin (dB)	Limit (dBµV)
0.150000	45.0	Off	L1	19.5	21.0	66.0
0.182000	41.7	Off	L1	19.5	22.7	64.4
0.206000	44.0	Off	L1	19.4	19.4	63.4
0.342000	36.7	Off	L1	19.5	22.5	59.2
0.422000	39.1	Off	L1	19.5	18.3	57.4
0.526000	34.2	Off	L1	19.4	21.8	56.0
1.014000	34.8	Off	L1	19.6	21.2	56.0
2.006000	35.8	Off	L1	19.7	20.2	56.0
3.038000	32.7	Off	L1	19.7	23.3	56.0
4.870000	28.2	Off	L1	19.8	27.8	56.0
13.558000	46.3	Off	L1	19.9	13.7	60.0

**Final Result : Average**

Frequency (MHz)	Average (dBµV)	Filter	Line	Corr. (dB)	Margin (dB)	Limit (dBµV)
0.150000	27.1	Off	L1	19.5	28.9	56.0
0.182000	25.4	Off	L1	19.5	29.0	54.4
0.206000	30.7	Off	L1	19.4	22.7	53.4
0.342000	24.6	Off	L1	19.5	24.6	49.2
0.422000	27.0	Off	L1	19.5	20.4	47.4
0.526000	21.3	Off	L1	19.4	24.7	46.0
1.014000	30.2	Off	L1	19.6	15.8	46.0
2.006000	31.7	Off	L1	19.7	14.3	46.0
3.038000	25.3	Off	L1	19.7	20.7	46.0
4.870000	21.7	Off	L1	19.8	24.3	46.0
13.558000	43.1	Off	L1	19.9	6.9	50.0



Test Mode :	NFC Tx	Test Voltage :	120Vac / 60Hz
Function Type :	GSM850 Idle + Bluetooth Link + WLAN Link + Adapter + NFC Tx + Earphone		

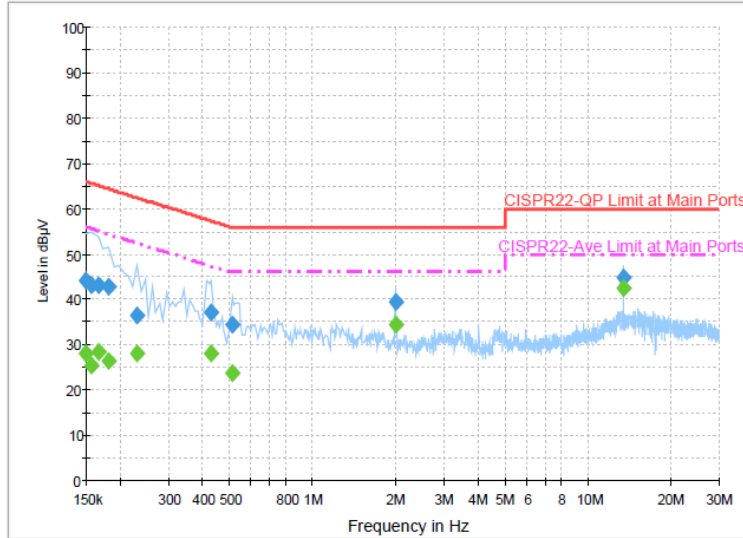

**Final Result : Quasi-Peak**

Frequency (MHz)	Quasi-Peak (dBµV)	Filter	Line	Corr. (dB)	Margin (dB)	Limit (dBµV)
0.150000	44.1	Off	N	19.5	21.9	66.0
0.158000	43.1	Off	N	19.5	22.5	65.6
0.166000	43.1	Off	N	19.4	22.1	65.2
0.182000	42.7	Off	N	19.5	21.7	64.4
0.230000	36.5	Off	N	19.6	25.9	62.4
0.430000	37.3	Off	N	19.5	20.0	57.3
0.510000	34.3	Off	N	19.5	21.7	56.0
2.006000	39.3	Off	N	19.7	16.7	56.0
13.558000	44.9	Off	N	20.0	15.1	60.0

**Final Result : Average**

Frequency (MHz)	Average (dBµV)	Filter	Line	Corr. (dB)	Margin (dB)	Limit (dBµV)
0.150000	28.3	Off	N	19.5	27.7	56.0
0.158000	25.5	Off	N	19.5	30.1	55.6
0.166000	28.4	Off	N	19.4	26.8	55.2
0.182000	26.4	Off	N	19.5	28.0	54.4
0.230000	28.2	Off	N	19.6	24.2	52.4
0.430000	28.0	Off	N	19.5	19.3	47.3
0.510000	23.7	Off	N	19.5	22.3	46.0
2.006000	34.4	Off	N	19.7	11.6	46.0
13.558000	42.4	Off	N	20.0	7.6	50.0

Remark: 13.558MHz is the NFC RF fundamental signal.



## Appendix B. Test Results of Conducted Test Items

### B.1 Test Result of 20dB Spectrum Bandwidth

Test mode	NFC Tx	Test Frequency (MHz)	13.56
20dB Bandwidth (kHz)	2.640	99% OccupiedBW (kHz)	2.240
Frequency range (MHz)	$f_L > 13.553$	13.558500	<b>Test Result</b>
	$f_H < 13.567$	13.561140	<b>Complies</b>

### B.2 Test Result of Frequency Stability

Voltage vs. Frequency Stability		Temperature vs. Frequency Stability	
Voltage (Vac)	Measurement Frequency (MHz)	Temperature (°C)	Measurement Frequency (MHz)
120	13.559820	-20	13.559930
102	13.559820	-10	13.559910
138	13.559820	0	13.559880
		10	13.559860
		20	13.559840
		30	13.559800
		40	13.559800
		50	13.559780
Max.Deviation (MHz)	-0.000180	Max.Deviation (MHz)	-0.000220
Max.Deviation (ppm)	-13.2743	Max.Deviation (ppm)	-16.2242
Limit	FS < ±100 ppm	Limit	FS < ±100 ppm
Test Result	<b>PASS</b>	Test Result	<b>PASS</b>



# Appendix C. Test Results of Radiated Test Items

## C.1 Test Result of Field Strength of Fundamental Emissions

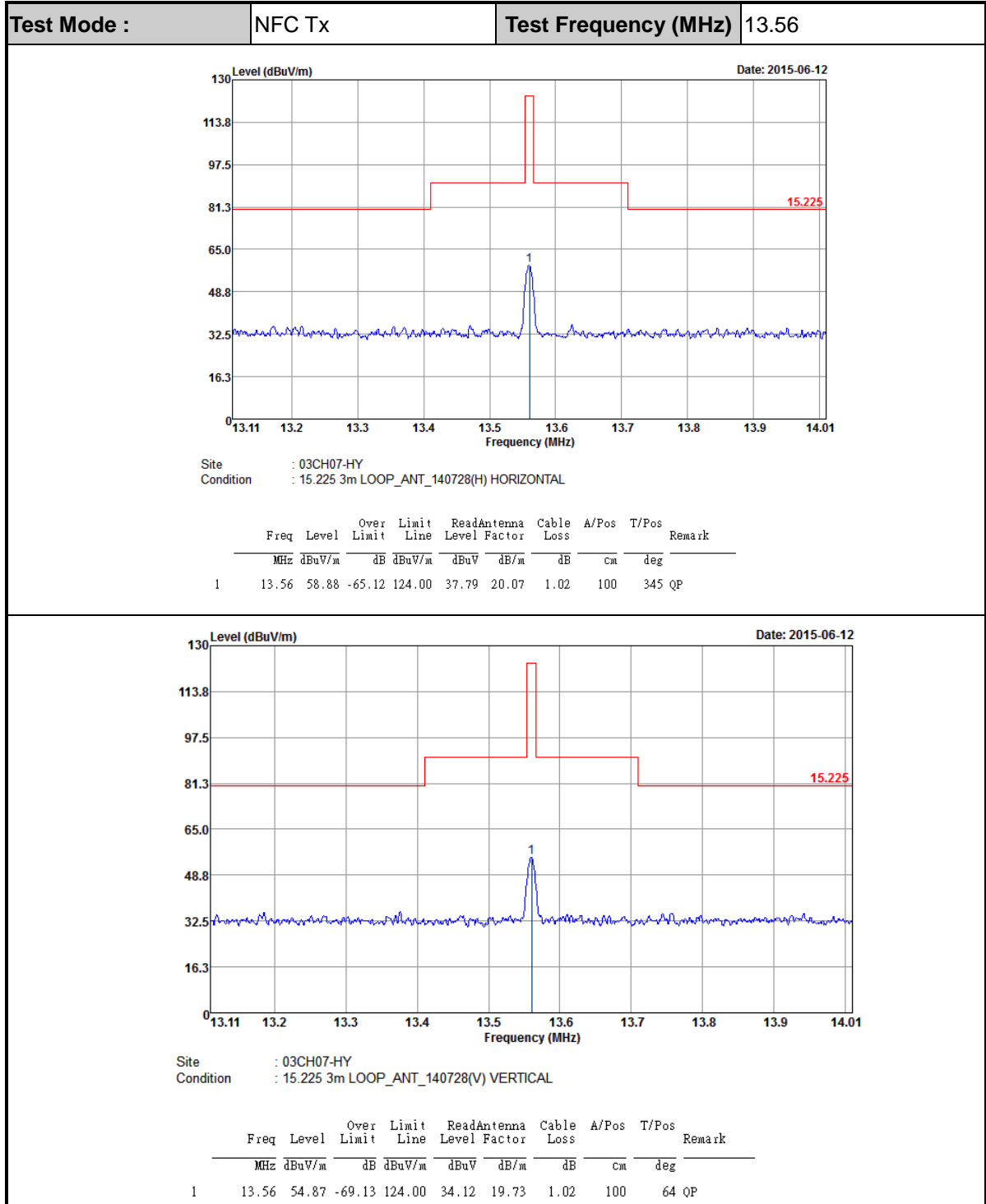

**Note:** All NFC's spurious emissions are below 20dB of limits.



**C.2 Results of Radiated Emissions (9kHz~30MHz)**

Test Mode :		NFC Tx			Polarization :		Horizontal		
Frequency ( MHz )	Level ( dBμV/m )	Over Limit ( dB )	Limit Line ( dBμV/m )	Read Level (dBμV)	Antenna Factor ( dB )	Cable Loss ( dB )	Ant Pos ( cm )	Table Pos ( deg )	Remark
0.01803	26.96	-95.53	122.49	5.7	20.24	1.02	-	-	Average
0.06624	21.64	-89.54	111.18	0.61	20.01	1.02	-	-	Average
0.09758	22.06	-85.76	107.82	1.08	19.96	1.02	-	-	QP
0.13636	20.66	-84.25	104.91	-0.3	19.94	1.02	-	-	Average
0.3047	39.77	-58.16	97.93	18.86	19.89	1.02	-	-	Average
5.514	36.58	-33.42	70	15.57	19.99	1.02	-	-	QP
11.336	37.01	-32.99	70	15.92	20.07	1.02	-	-	QP
13.56	57.97	-	-	36.88	20.07	1.02	-	-	QP
22.615	37.77	-32.23	70	15.39	20.61	1.77	100	0	QP
27.58	37.34	-32.66	70	14.89	20.68	1.77	-	-	QP

Test Mode :		NFC Tx			Polarization :		Vertical		
Frequency ( MHz )	Level ( dBμV/m )	Over Limit ( dB )	Limit Line ( dBμV/m )	Read Level (dBμV)	Antenna Factor ( dB )	Cable Loss ( dB )	Ant Pos ( cm )	Table Pos ( deg )	Remark
0.02456	25.52	-94.28	119.8	4.38	20.12	1.02	-	-	Average
0.07413	22.04	-88.16	110.2	0.99	20.03	1.02	-	-	Average
0.10318	21.44	-85.89	107.33	0.43	19.99	1.02	-	-	QP
0.125	21.03	-84.64	105.67	0.05	19.96	1.02	-	-	Average
0.34584	38.82	-58.01	96.83	17.89	19.91	1.02	-	-	Average
1.008	37.13	-30.4	67.53	16.2	19.91	1.02	100	0	QP
9.384	35.41	-34.59	70	14.58	19.81	1.02	-	-	QP
13.56	53.57	-	-	32.82	19.73	1.02	-	-	QP
16.783	37.59	-32.41	70	16.91	19.66	1.02	-	-	QP
25.07	37.55	-32.45	70	15.71	20.07	1.77	-	-	QP

**Note:**

1. 13.56 MHz is fundamental signal which can be ignored.
2. The amplitude of spurious emissions which are attenuated by more than 20dB below the permissible value has no need to be reported.
3. Distance extrapolation factor = 40 log (specific distance / test distance) (dB);
4. Limit line = specific limits (dBμV) + distance extrapolation factor.



C.3 Results of Radiated Emissions (30MHz~1GHz)

Test Mode :	NFC Tx	Polarization :	Horizontal
-------------	--------	----------------	------------

Frequency ( MHz )	Level ( dBμV/m )	Over Limit ( dB )	Limit Line ( dBμV/m )	Read Level ( dBμV )	Antenna Factor ( dB )	Cable Loss ( dB )	Preamp Factor ( dB )	Ant Pos ( cm )	Table Pos ( deg )	Remark
57.81	29.77	-10.23	40	53.1	6.16	1.77	31.26	100	0	Peak
117.21	27.28	-16.22	43.5	44.78	11.24	2.38	31.12	-	-	Peak
256.26	25.81	-20.19	46	40.49	13.36	2.96	31	-	-	Peak
508.6	21.74	-24.26	46	30.41	18.08	3.89	30.64	-	-	Peak
677.3	24.95	-21.05	46	30.58	20.47	4.35	30.45	-	-	Peak
839	28.52	-17.48	46	31.04	23.16	4.7	30.38	-	-	Peak

Test Mode :	NFC Tx	Polarization :	Vertical
-------------	--------	----------------	----------

Frequency ( MHz )	Level ( dBμV/m )	Over Limit ( dB )	Limit Line ( dBμV/m )	Read Level ( dBμV )	Antenna Factor ( dB )	Cable Loss ( dB )	Preamp Factor ( dB )	Ant Pos ( cm )	Table Pos ( deg )	Remark
76.17	26.17	-13.83	40	48.44	6.87	2.06	31.2	-	-	Peak
116.94	21.19	-22.31	43.5	38.7	11.24	2.38	31.13	-	-	Peak
208.2	33.74	-9.76	43.5	52.97	9.18	2.69	31.1	100	0	Peak
435.8	20.99	-25.01	46	31.13	16.95	3.63	30.72	-	-	Peak
631.1	24.31	-21.69	46	30.23	20.4	4.22	30.54	-	-	Peak
777.4	26.9	-19.1	46	30.75	22.02	4.48	30.35	-	-	Peak

Note:

1. The amplitude of spurious emissions which are attenuated by more than 20dB below the permissible value has no need to be reported.
2. Emission level (dBμV/m) = 20 log Emission level (μV/m).
3. Corrected Reading: Antenna Factor + Cable Loss + Read Level - Preamp Factor= Level.